

Service Training



Self-study Programme 340

The Passat 2006 Electrical System

Design and Function



The Passat 2006 features further innovations in the area of vehicle electrics and electronics.

The developers have paid particular attention to comfort in this car.

One example is the entry and start authorisation switch. For the first time, you do not have to turn the ignition key to start the engine.

This self-study programme should help you get to know the electrical system in the Passat 2006 and become familiar with the new features.

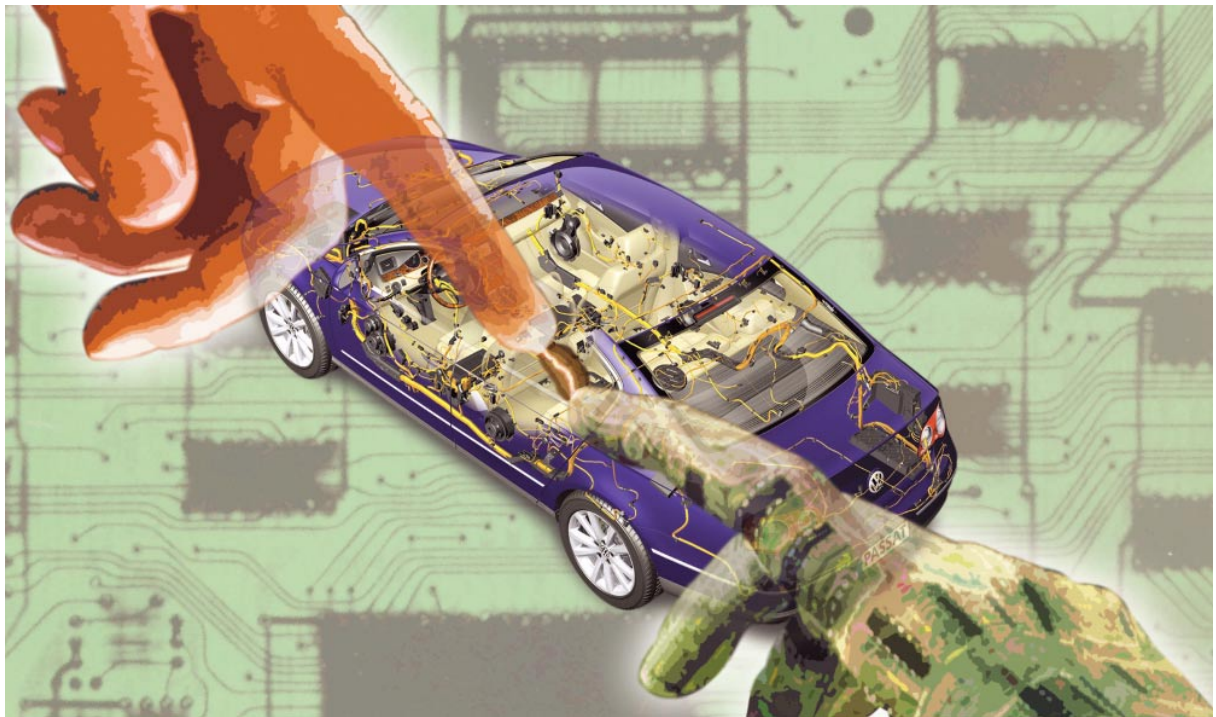

S340_072

NEW

The self-study programme shows the design and function of new developments. The contents will not be updated.

For current testing, adjustment and repair instructions, refer to the relevant service literature.

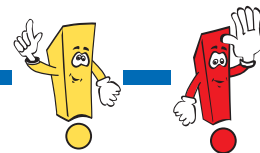

Important Note



Introduction	4
Data Bus Systems	
Control Units for Powertrain CAN Data Bus	8
Control Units for Convenience CAN Data Bus	10
Control Units for Infotainment CAN Data Bus Combi and Diagnosis	12
Sub-bus Systems	14
Onboard Power Supply	
Electronics Box	18
Relay Carriers and Fuse Boxes	20
Onboard Power Supply Control Unit	22
Exterior lights	24
Data Bus Diagnostic Interface	32
Control Unit with Display in Dash Panel Insert	34
Convenience System Central Control Unit	38
Immobilizer IV	40
Start-Stop System	44
Electronic Steering Column Lock Control Unit	46
Convenience and Safety Electronics	
Corning Light System (Advanced Frontlighting System)	48
Customisation	50
Parking Aid	52
Transformer	54
Service	56
Test Yourself	58



Introduction



Fuse Boxes and Relay Locations in the Onboard Power Supply

Locations

The Passat 2006 onboard power supply is decentralised and is therefore similar to the Golf 2004 system. The Passat also has a fuse box on the right-hand side of the dash panel due to the large number of electrical consumers.

The distribution of the fuse boxes and relays among different locations allows fast and precise fault diagnosis.



Fuse box,
in right-hand side of
dash panel

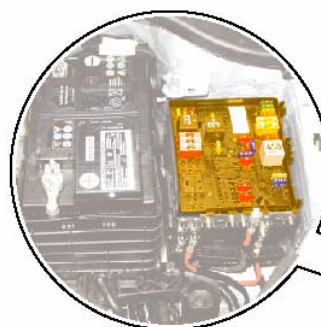

Electronics box,
on left of engine compartment

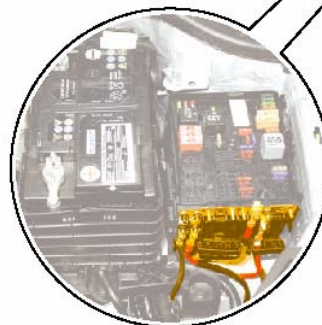

Back-up fuse box,
on left of engine compartment

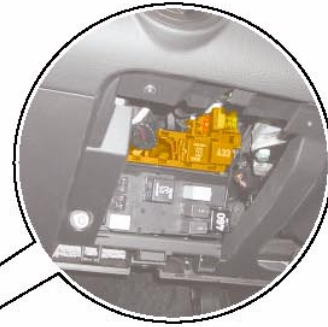
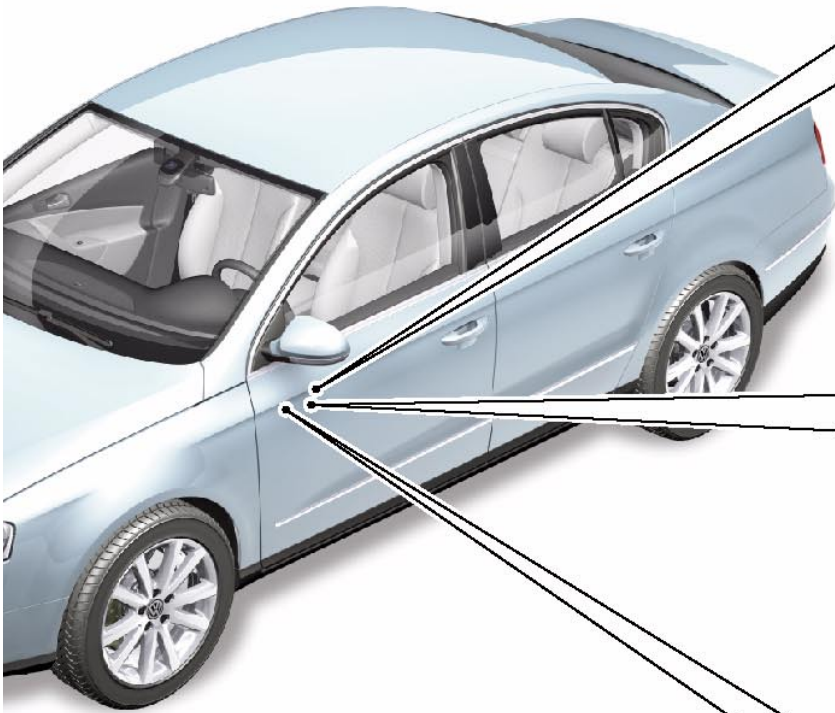

Relay carrier,
on left under dash panel,
above onboard power supply
control unit



Relay carrier on onboard power
supply control unit,
on left under dash panel

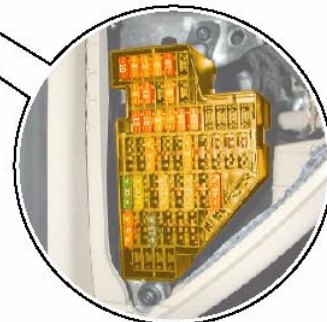

Fuse box,
on left in dash panel

S340_001

Introduction



Networking Concept

Overview of networked control units

The data bus diagnostic interface J533 forms the interface for communication among the following data bus systems:

- Powertrain CAN data bus
- Convenience CAN data bus
- Infotainment CAN data bus
- Combi CAN data bus
- Diagnostics CAN data bus

The following data bus systems are connected downstream of a CAN data bus system as a sub-bus system:

- LIN data bus
- CAN data bus, electromechanical parking brake
- Sensor CAN data bus
- Cornering lights CAN data bus
- Serial data bus

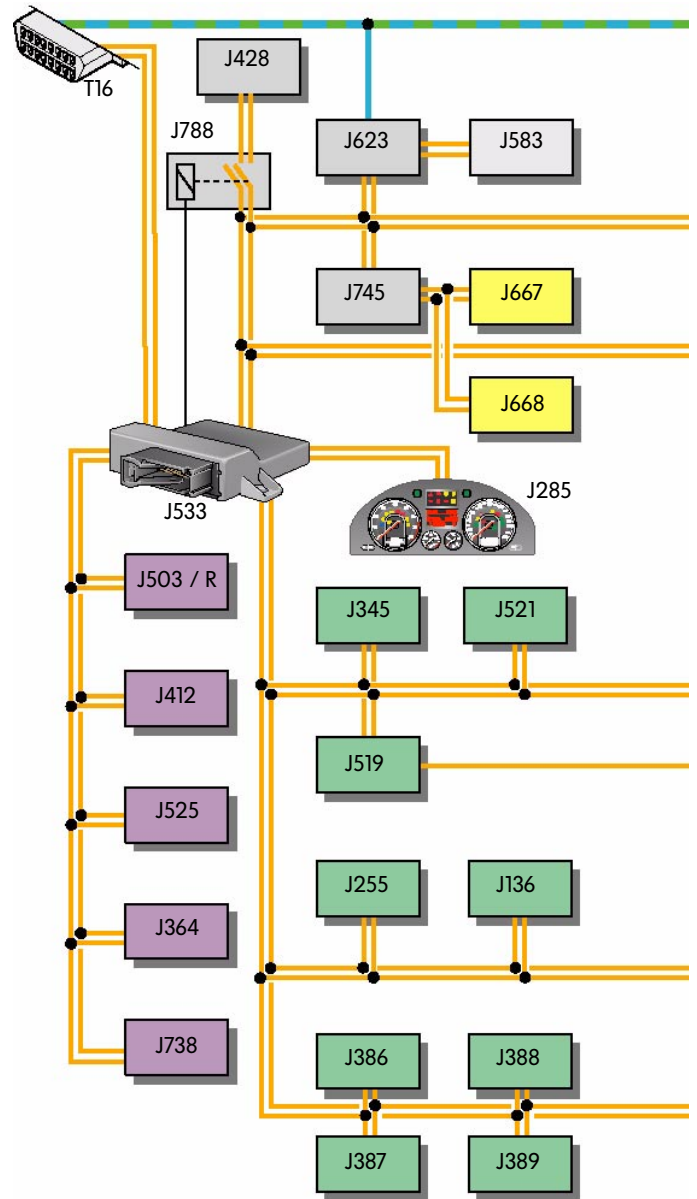
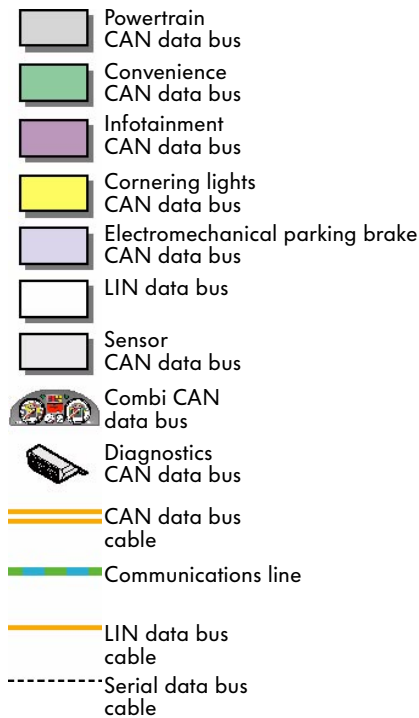

S340_003

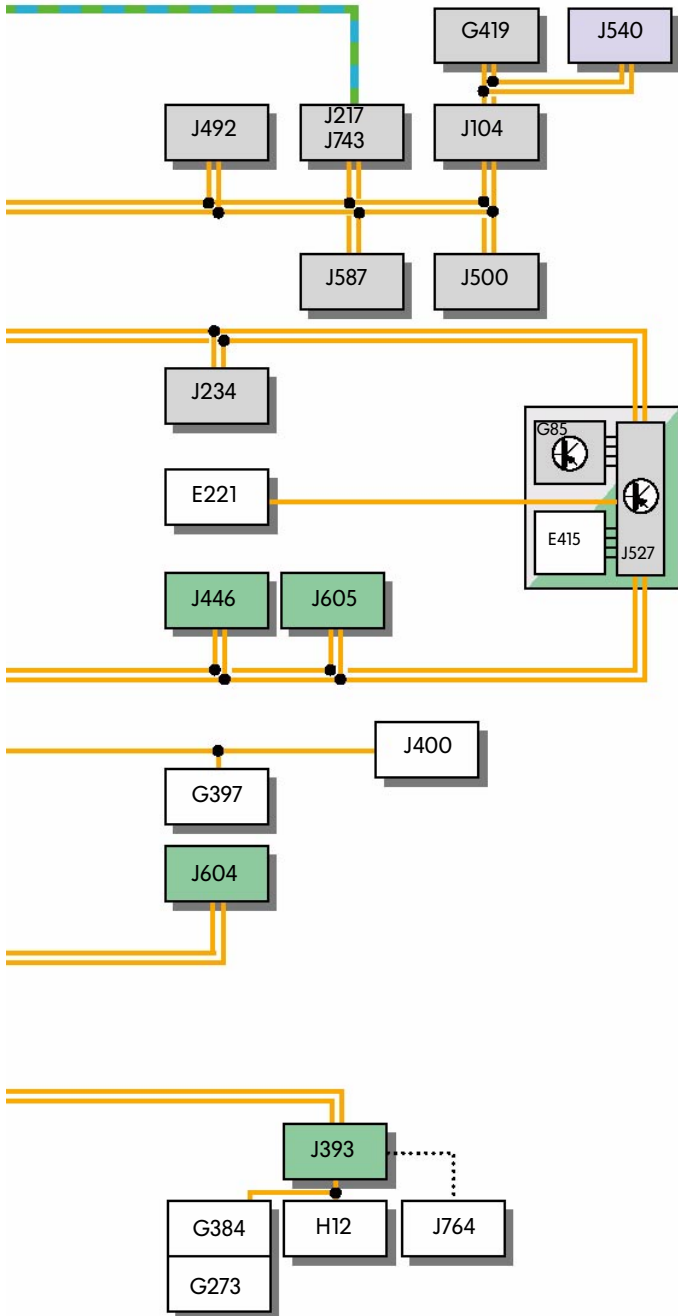

- E221 Operating unit in steering wheel
- E415 Entry and start authorisation switch
- G85 Steering angle sender
- G273 Interior monitoring sensor
- G384 Vehicle inclination sender
- G397 Rain and light detector sensor
- G419 ESP sensor unit
- H12 Alarm horn
- J104 ABS control unit
- J136 Seat and steering column adjustment control unit with memory
- J217 Automatic gearbox control unit
- J234 Airbag control unit
- J255 Climatronic control unit
- J285 Control unit with display in dash panel insert
- J345 Trailer detector control unit
- J364 Auxiliary heater control unit
- J386 Driver door control unit
- J387 Front passenger door control unit
- J388 Rear left door control unit
- J389 Rear right door control unit
- J393 Convenience system central control unit
- J400 Wiper motor control unit
- J412 Mobile telephone operating electronics control unit
- J428 Adaptive cruise control unit
- J446 Parking aid control unit
- J492 Four-wheel drive control unit
- J500 Power steering control unit
- J503 Control unit with display for radio and navigation
- J519 Onboard power supply control unit
- J521 Front passenger seat position with memory control unit
- J525 Digital sound package control unit
- J527 Steering column electronics control unit
- J533 Data bus diagnostic interface
- J540 Electromechanical parking brake control unit
- J583 NOx sensor control unit
- J587 Selector lever sensors control unit
- J604 Auxiliary air heater control unit
- J605 Boot lid control unit
- J623 Engine control unit
- J667 Power output module for left headlight
- J668 Power output module for right headlight
- J738 Telephone controls control unit
- J743 Mechatronics for direct shift gearbox
- J745 Cornering light and headlight range control unit
- J764 Electronic steering column lock control unit
- J788 Powertrain CAN bus isolation relay
- R Radio
- T16 Diagnosis connection 16-pin connector

S340_002

Data Bus Systems

Control Units for Powertrain CAN Data Bus

Control units and locations



The adjacent diagram shows the control units that are involved in the powertrain CAN data bus communication as well as their locations.

The data transfer speed is 500kbit/s. The transfer occurs via the CAN high cable and the CAN low cable. The CAN cables are twisted together for secure data transfer.

The powertrain CAN data bus is not suitable for use with a single cable – data transfer would not be possible if one CAN cable fails.



Due to new terminology for the names of components, some terms may be different to those used in other self-study programmes.

Headlight range control, control unit J431, on right-hand side of glove compartment

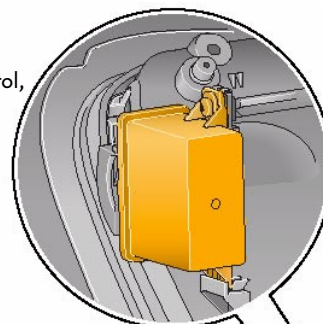

ABS control unit J104, on the bulkhead, on right inside engine compartment

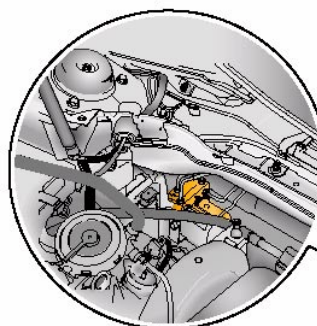

Adaptive cruise control unit J428 *, behind the brand badge

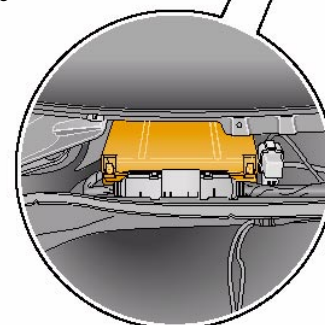

Engine control unit J623, under the plenum chamber cover

* To be used at a later point in time.

Selector lever sensors control unit J587,
under centre console at front

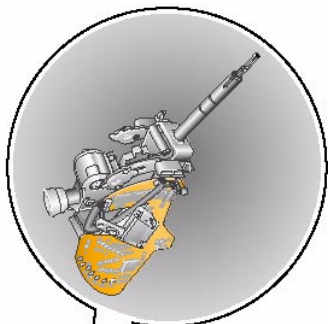

Airbag control unit,
under centre console at front

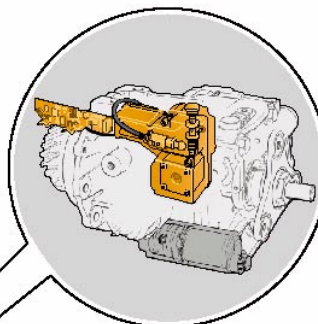
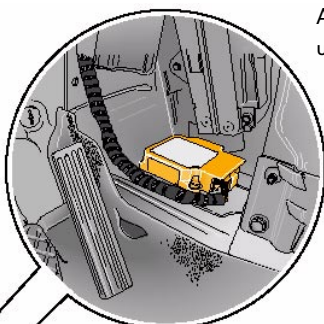

Four-wheel drive control unit J492 *,
on the Haldex coupling, in front of the rear axle

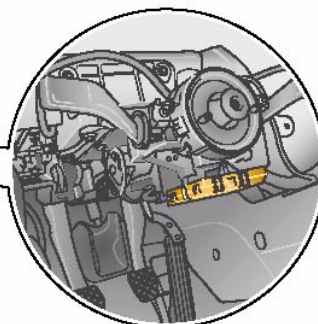

Steering column electronics control unit J527,
under the steering column switch

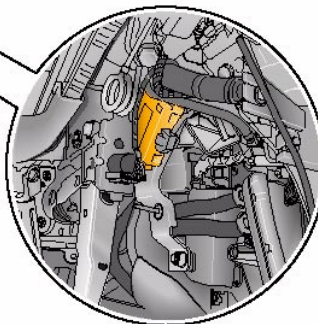

Data bus diagnostic interface J533,
on left under dash panel

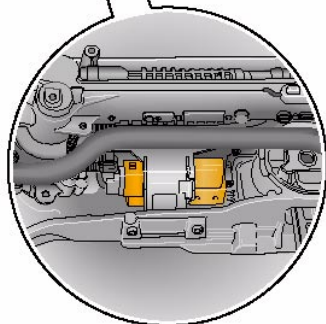
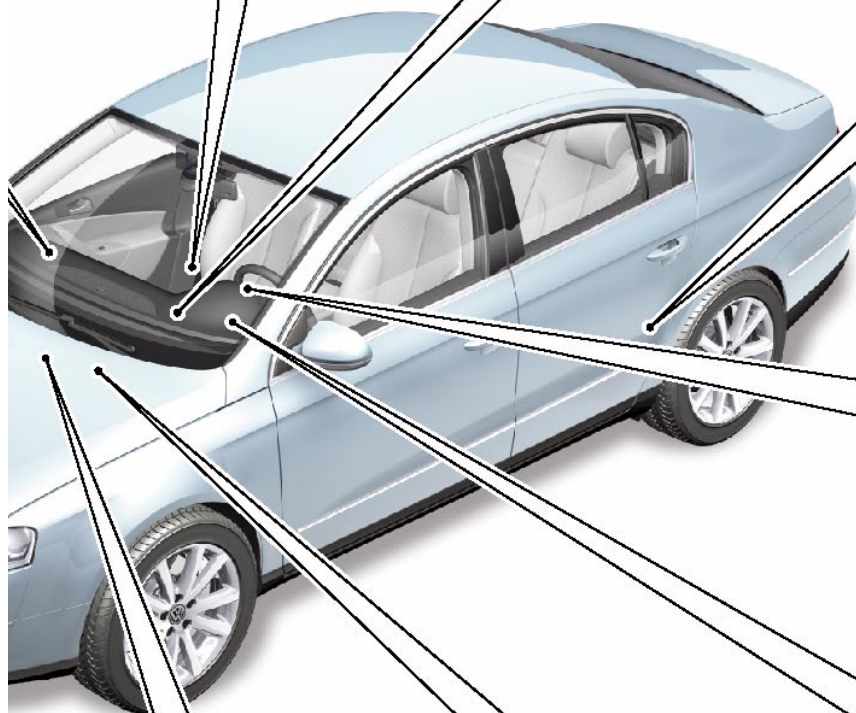

Power steering control unit J500,
on the steering rack near the
bulkhead

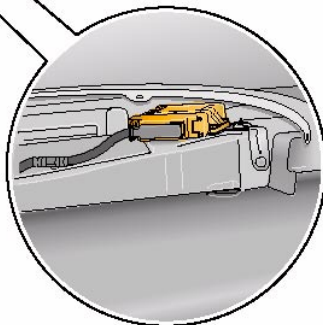

Automatic gearbox control unit J217,
in front left wheel housing

S340_004



Data Bus Systems

Control Units for Convenience CAN Data Bus

Control units and locations



The adjacent diagram shows the control units that are involved in the convenience CAN data bus communication as well as their locations. The data transfer speed is 100 kbit/s. The transfer occurs via the CAN high cable and the CAN low cable. The CAN cables are twisted together for secure data transfer.

The convenience CAN data bus is suitable for use with a single cable – data transfer would still be possible if one CAN cable fails.

Front passenger seat position with memory J521, under passenger seat

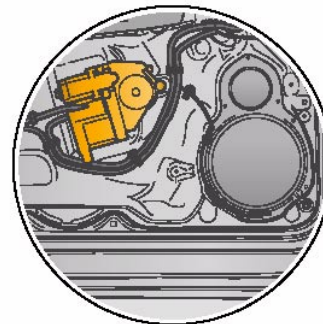
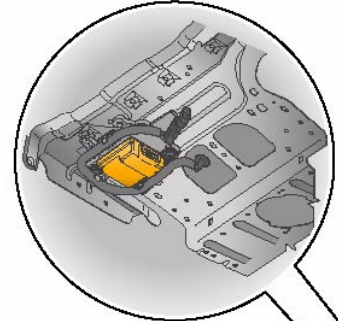

Door control units J386, J387, J388, J389, in the doors

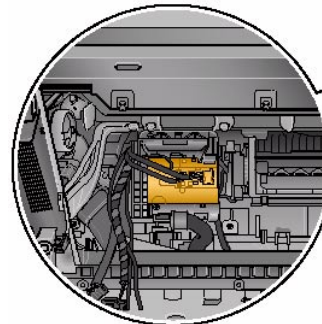

Convenience system central control unit J393, on right under dash panel



Climatronic control unit J255, in middle of dash panel

Parking aid control unit J446,
in the side section at rear right

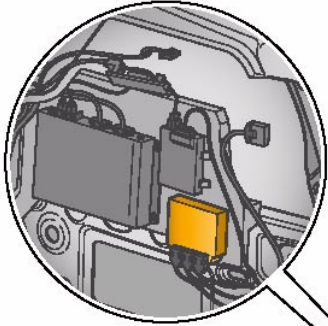

Trailer detector control unit J345,
in the side section at rear left

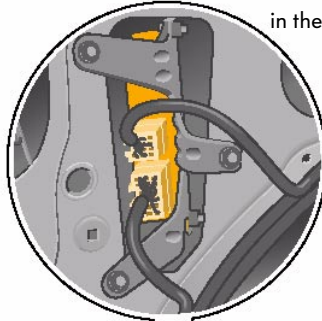

Multifunction steering wheel control unit J453,
in the steering wheel

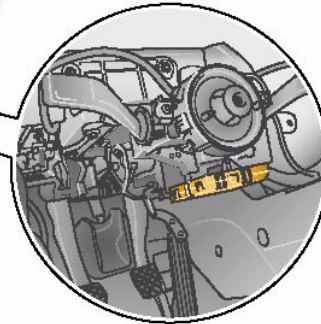

Steering column electronics control unit J527,
in the steering column

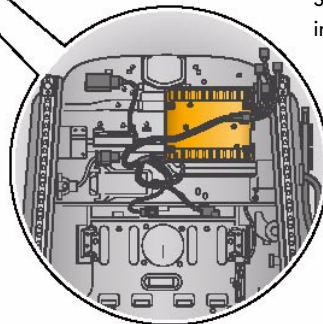

Seat and steering column adjustment control unit
with memory J136,
under driver's seat

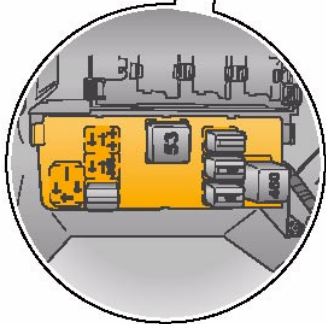

Onboard power supply control unit J519,
on relay carrier under the dash panel

S340_005

Data Bus Systems

Control Units for Infotainment CAN Data Bus Combi and Diagnosis



Control units and locations

The adjacent diagram shows the control units that are involved in the infotainment and combi CAN data bus communication as well as their locations.

Infotainment CAN data bus

The data transfer speed is 100 kbit/s. The transfer occurs via the CAN high cable and the CAN low cable. The CAN cables are twisted together for secure data transfer.

The infotainment CAN data bus is suitable for use with a single cable – data transfer would still be possible if one CAN cable fails.

Combi and diagnosis CAN data bus

The data transfer speed is 500 kbit/s. The transfer occurs via the CAN high cable and the CAN low cable. The CAN cables are twisted together for secure data transfer.

The combi and diagnosis CAN data bus systems are not suitable for use with a single cable – data transfer would not be possible if one CAN cable fails.



CD changer R41,
in glove compartment

Auxiliary heater control unit J364,
in right wheel housing

Control unit with display for radio and navigation J503, in the dash panel

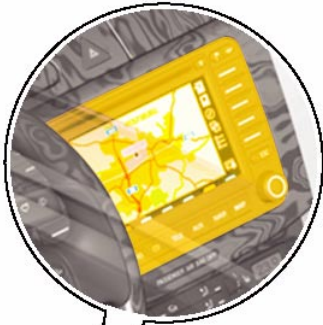

Mobile telephone operating electronics control unit J412, under passenger seat

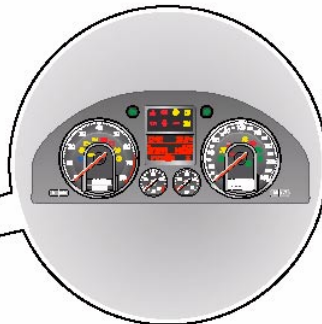
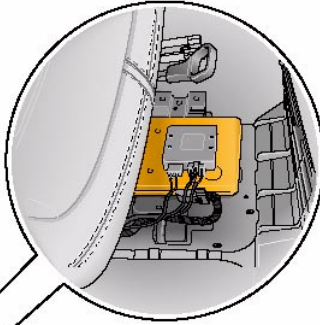

Control unit with display in dash panel insert J285

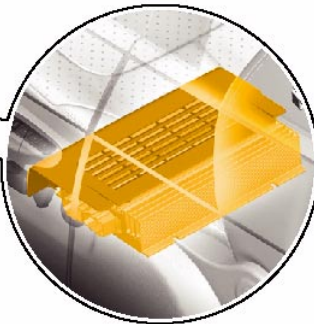

Digital sound package control unit J525, under driver's seat

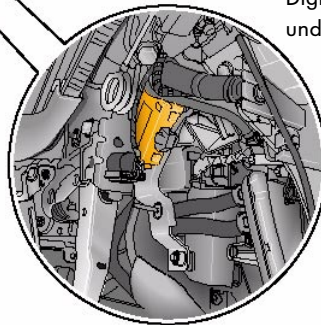

Data bus diagnostic interface J533, in footwell on driver's side, near pedals



Diagnosis connector T16 on left under dash panel, driver's side



S340_007

Data Bus Systems

Sub-bus Systems

LIN data bus



The Local Interconnect Network is a local system that transfers data via a single-wire connection at a data transfer rate of 1 - 20 kbit/s.

The transfer rate is stored in the master control unit software. The data exchange occurs between a master control unit and up to 16 slave control units. The communication between the individual subscribers is initiated exclusively by the master control unit that can also communicate on the CAN data bus.

Control Units for LIN Data Bus

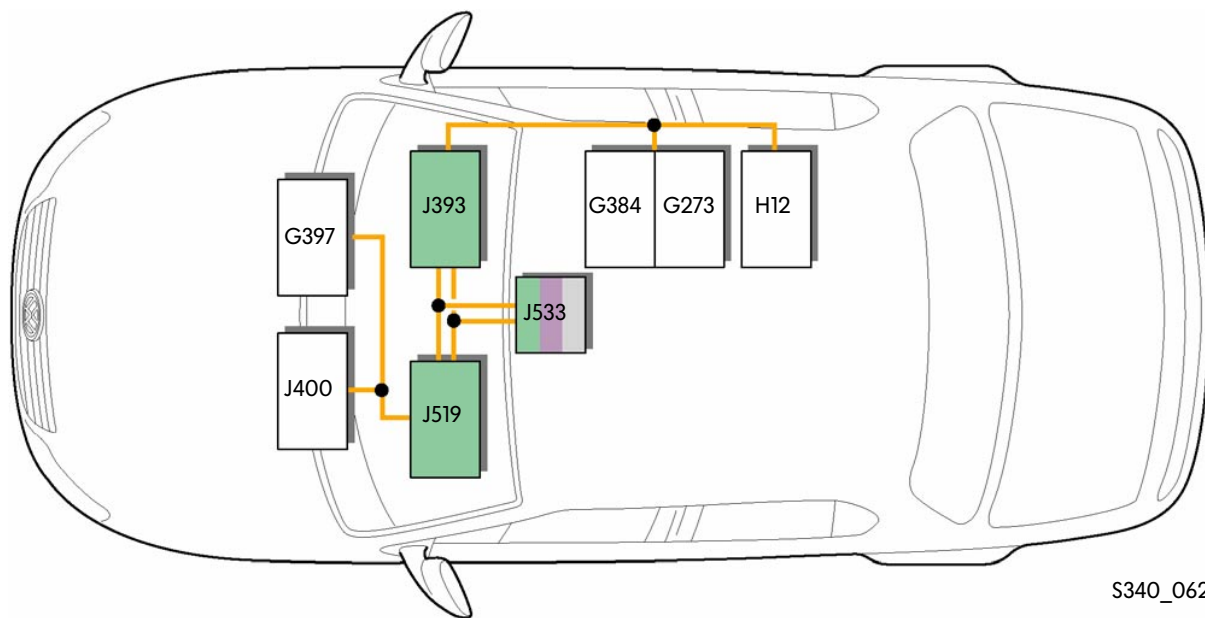

S340_062

Legend

- G273 Interior monitoring sensor
- G384 Vehicle inclination sender
- G397 Rain and light sensor
- H12 Alarm horn
- J393 Convenience system central control unit
- J400 Wiper motor control unit
- J519 Onboard power supply control unit
- J533 Data bus diagnostic interface

Electromechanical CAN data bus

The data transfer speed of the electromechanical parking brake CAN data bus is 500 kbit/s. The transfer occurs via the CAN high cable and the CAN low cable. The CAN cables are twisted together for secure data transfer.

The powertrain CAN data bus is not suitable for use with a single cable – data transfer would not be possible if one CAN cable fails.



Control units for electromechanical parking brake CAN data bus

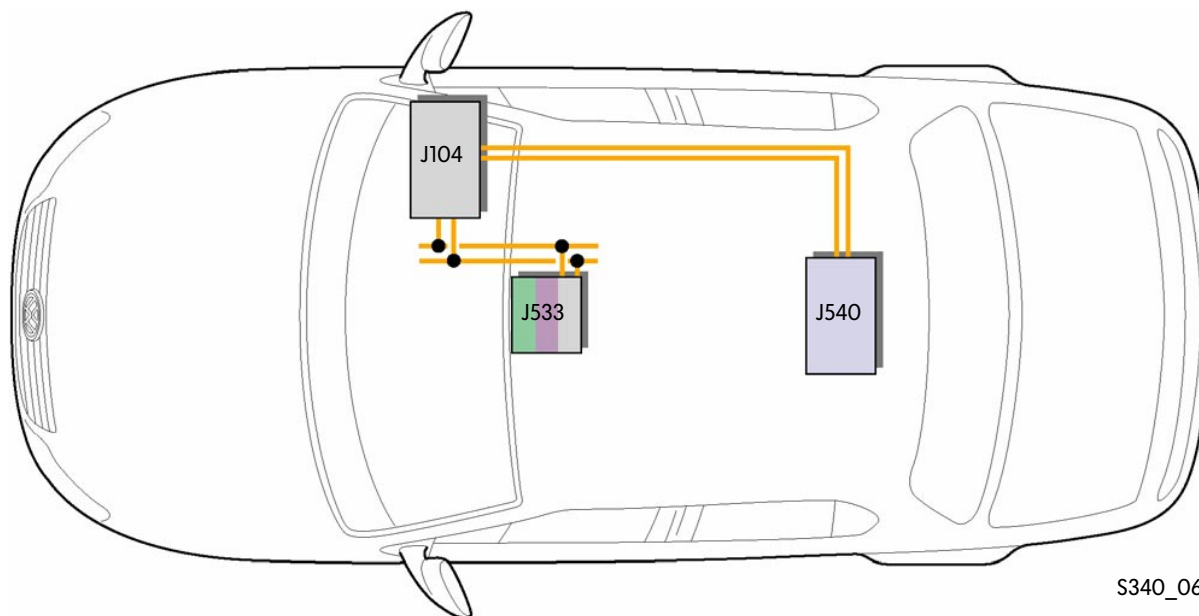

S340_063

Legend

- J104 ABS control unit
- J533 Data bus diagnostic interface
- J540 Control unit for electromechanical parking brake



Additional CAN data bus systems are necessary due to the high requirements (data rate and quantity).

Data Bus Systems

Cornering Lights (Advanced Frontlighting System) CAN Data Bus



The data transfer speed of the cornering light CAN data bus is 500 kbit/s. The transfer occurs via the CAN high cable and the CAN low cable. The CAN cables are twisted together for secure data transfer.

The cornering light CAN data bus is not suitable for use with a single cable – data transfer would not be possible if one CAN cable fails.

Control units for cornering light CAN data bus

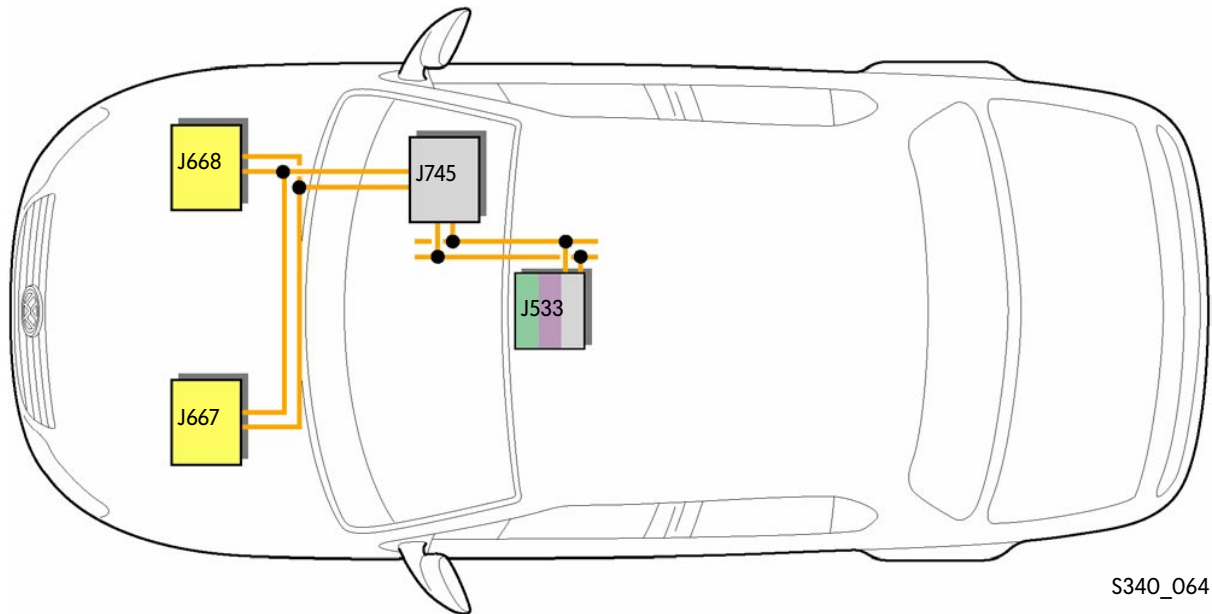

S340_064

Legend

- J533 Data bus diagnostic interface
- J667 Power output module for left headlight
- J668 Power output module for right headlight
- J745 Cornering light and headlight range control unit

Sensor CAN data bus

The data transfer for the sensor CAN data bus is the same as the cornering light CAN data bus and transfers the data between the engine control unit and the NOx sensor control unit.

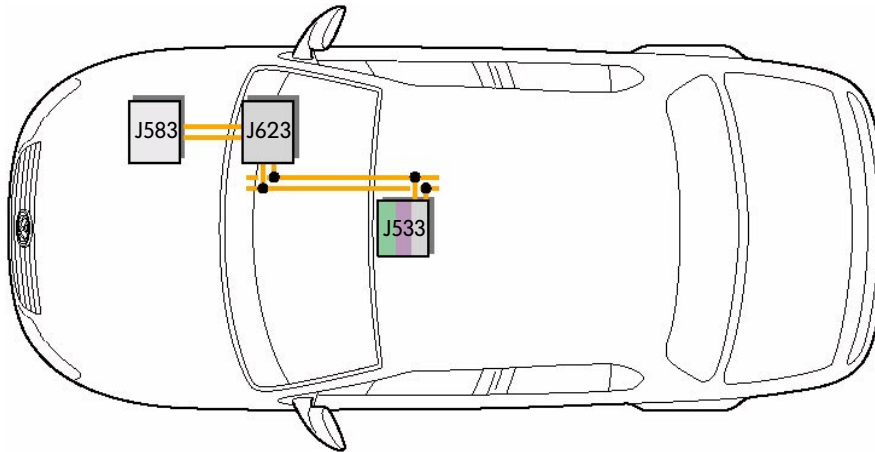

S340_065

Legend

- J533 Data bus diagnostic interface
- J583 NOx sensor control unit
- J623 Engine control unit

Serial data bus

The serial data bus transfers the data via a single-wire connection at 9800 kbit/s between the electronic steering column lock control unit and the convenience system central control unit. Using the serial data bus system increases theft protection compared with use of the LIN data bus system.

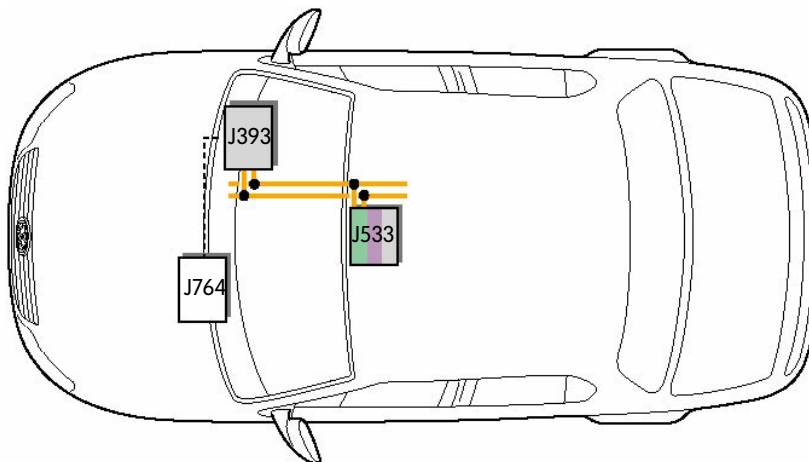

S340_066

Legend

- J533 Data bus diagnostic interface
- J393 Convenience system central control unit
- J764 Electronic steering column lock control unit

Onboard Power Supply

Electronics Box

Location

The electronics box is mounted at the front right in the engine compartment.

Description

All fuses and relays for protection and control of the electrical components in the engine compartment are accommodated in the electronics box.



There is therefore no cable running into the interior and back.

Troubleshooting is made easier, the protection is configured better to the consumer and multiple assignment of fuses is avoided to a great extent.

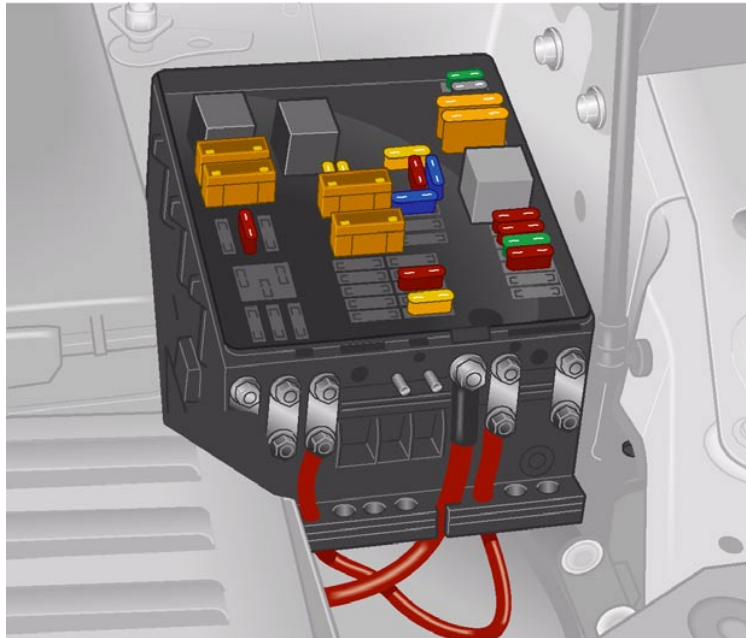

S340_010



Please refer to the ELSA electronic service information system for the current assignment with fuses and relays in the electronics box.

Electronics Box

The electronics box also contains the following relay in addition to the fuses for the components in the engine compartment:

- Voltage supply relay terminal 30 J317

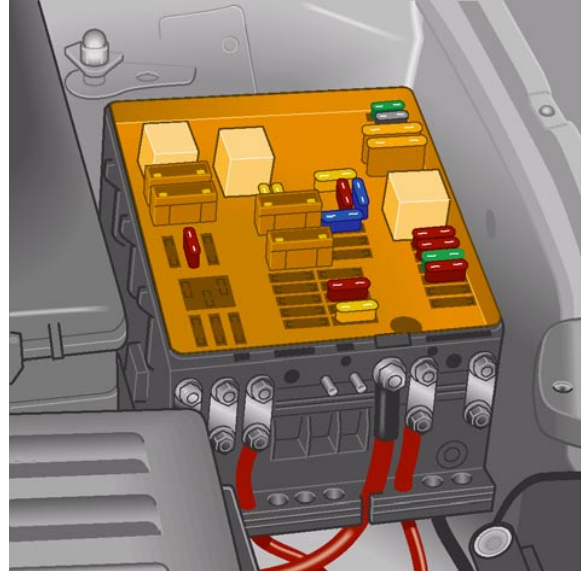

S340_011



Back-up fuse box

The back-up fuse box contains the fuses for

- the alternator,
- the electromechanical power steering,
- the radiator fan,
- the ABS control unit.

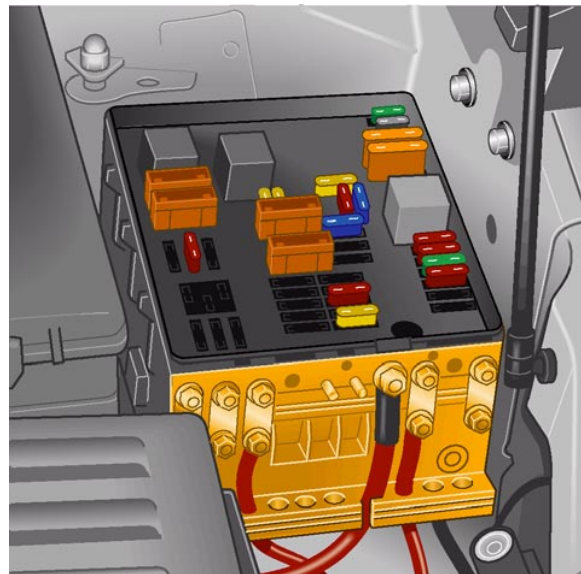

S340_012

Onboard Power Supply

Relay Carriers and Fuse Boxes

Locations

The relay carrier and the onboard power supply control unit are under the left-hand side of the dash panel.

Relay carrier

The relays connected to the relay carrier depend on the vehicle version and the equipment. On vehicles with heated seats, the circuit breakers for the heating elements (thermal fuses) are also mounted on the relay carrier.

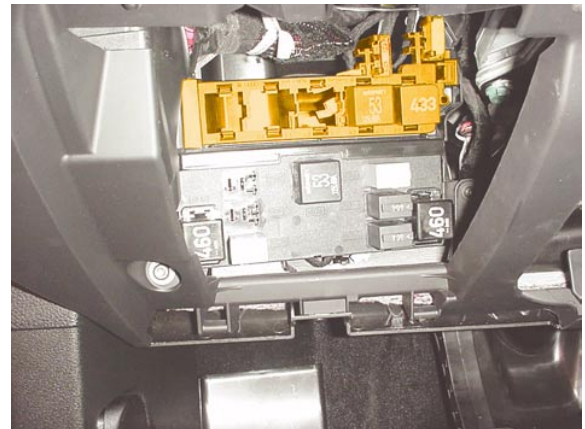

S340_008

Relay carrier on onboard power supply control unit

There is an additional relay carrier on the onboard power supply control unit.

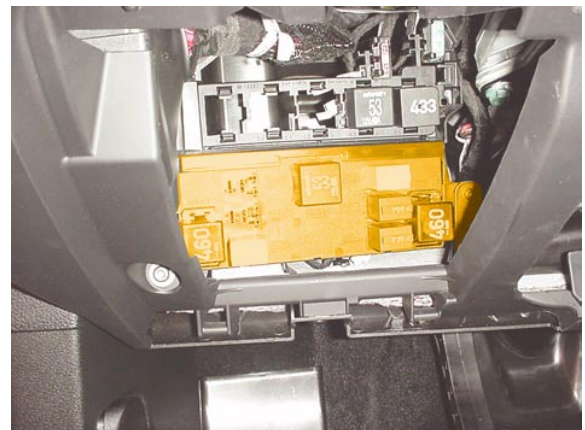

S340_009

Left-hand fuse box

The fuse box is on the left-hand side of the dash panel behind the cover.

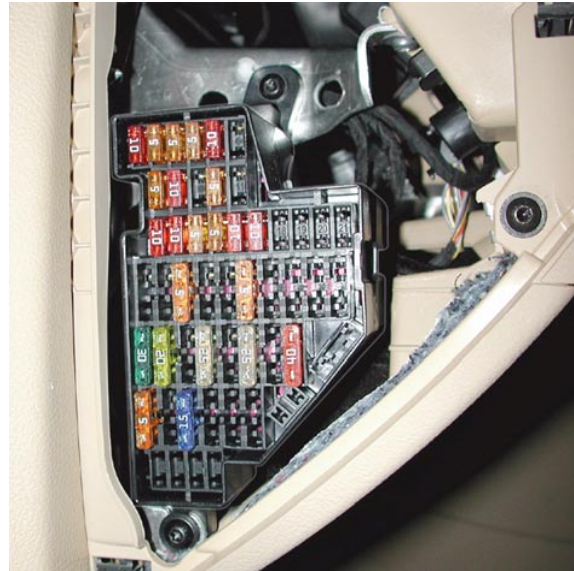

S340_013



Right-hand fuse box

The fuse box is on the right-hand side of the dash panel behind the cover.

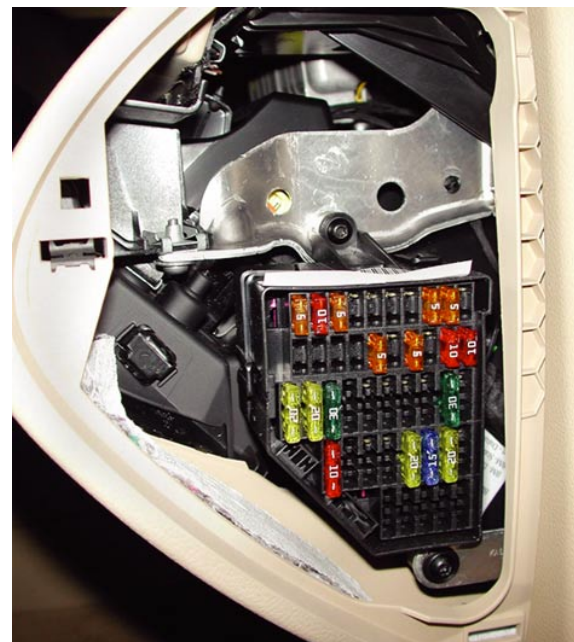

S340_014



Please refer to the ELSA electronic service information system for the current assignment of the fuses.

Onboard Power Supply

Onboard Power Supply Control Unit J519

Location

The onboard power supply control unit is on the left underneath the dash panel and forms a unit with the relay carrier.

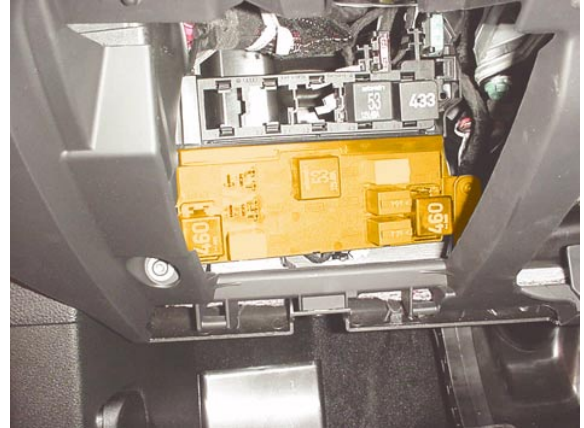

S340_009



Versions

The Passat is equipped with two different versions of the onboard power supply control unit.

- High version
for vehicles with fog lights and/or Bi-Xenon lights and customisation options.
- Medium version
for all other vehicle variants.



Fog lights can be retrofitted only if the medium version of the onboard power supply control unit is also exchanged for the high versions.

Tasks

The onboard power supply control unit switches and controls the following functions:

- Outside light control with bulb monitoring
The blown bulb is indicated by the corresponding warning light or as a text in the dash panel insert.
- Convenience lights with

Coming Home
After the vehicle doors are closed, the area surrounding the vehicle is illuminated by a lighting system on the vehicle.

Leaving Home
The area surrounding the vehicle will be illuminated by a lighting system when the car is unlocked with the remote control.

Dimmable instrument lighting

Gear selector lighting
- Interior light control
Terminal 30G, via which the interior lights are supplied with power, is switched by the onboard power supply control unit.
- Fuel pump supply
When you open the driver's door, the electrical fuel pump is supplied by the onboard power supply control unit with voltage.
After you start the engine, the voltage is supplied by the engine control unit.
- Front windscreen wiper
The CAN data bus signals are forwarded from the onboard power supply control unit to the wiper motor control unit
- Rear windscreen wipers
When you select reverse gear, the rear windscreen wiper is switched on (estate only).
- Windscreen and rear window washer pump
- Turn signal control
- Electrical load management
Switch-off under 11.8 V, as in Touran.
- Outside light control
- Heated rear windscreen
- Heated front windscreen
- Terminal control
The onboard power supply control unit controls terminal 75x via the X-contact relief relay. Terminal 15 is controlled via the relay for voltage supply terminal 15 in the electronics box. Terminal 50 is controlled via the relay for voltage supply terminal 50 in the electronics box.



Onboard Power Supply

Exterior Lights

Front headlights

Design

The shape of the headlights is no longer the classic double round design. "Large eyes" are formed by tubes around the dipped beam lights.

The large square full-beam reflector improves the full-beam performance considerably compared with the Passat 1997.



H7 headlights

The basic headlights use halogen technology. H7 lights are used for both the dipped and full-beam lights.

A voltage stabilising system used by the onboard power supply control unit increases the life of the bulbs.



S340_015

Xenon headlights

The Passat 2006 can be ordered with optional Bi-Xenon headlights with cornering light function.



S340_016



Xenon headlights are run with high-voltages of several 10,000 volts. Contact with this voltage can be fatal.

Therefore make sure you follow the safety guidelines given in the ELSA electronic service information system.

Tail lights

Design

The tail lights feature the double round light design. They are two-piece.

Tail lights in side section

The tail light, brake lights and indicators use LEDs and are integrated in the side section.

The advantages of LEDs over bulbs are faster response times, better signal formation and greater homogeneity of the illuminated areas.

Tail lights in the boot lid

The rear fog light is on the left of the boot lid and the reverse light is on the right. Normal bulbs are used here.



Tail light and
turn signal

Tail light and
brake signal

Rear fog light

Third brake light

A third brake light as well as the indicators mounted in the door mirrors compliment the headlights and tail lights and provide other road users with additional visual signals.

The third brake light at the top of the rear windscreen as well as the indicators in the door mirrors use LED technology.

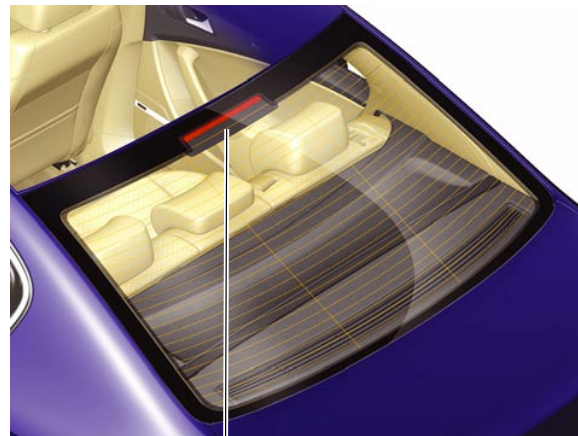

Third brake light



The whole unit will need to be replaced if individual LEDs are faulty.

Onboard Power Supply

Rotary light switch

In the midline and highline version of the onboard power supply control unit, the light switch is a semiconductor element. It is therefore only used for activation. The lights are controlled by the onboard power supply control unit output stage.

Rotary light switch without automatic headlight control

The light in the light switch is illuminated when terminal 75 is switched active.



S340_019

Rotary light switch with automatic headlight control

The symbol for automatic headlights is illuminated red when the light switch is set to “automatic headlight control”.

When the switch is in the “automatic headlight control” position and the rain and light detector sensor has detected night-time or darkness, the symbol will be illuminated green.

When the switch is in the “automatic headlight control” position and the rain and light detector sensor has detected day-time or light, the symbol will be illuminated light green.



S340_020



You will find further information on use of the rotary light switch and the warning lights in the Passat 2006 operating manual.

Indicator functions

The following indicator modes are available in the Passat 2006:

- Hazard warning lights
- Crash warning lights
- Emergency stop warning lights
- Turn signals
- Lane change flash
- Central locking flashing
- Anti-theft alarm flashing

The individual operating modes have different priorities. This allows a flash function to be activated even though another one is in use.

Priority 1 Hazard warning lights
Priority 2 Crash warning lights
Priority 3 Emergency stop warning lights

Priority 4 Turn signals, lane change flash
Priority 5 Anti-theft alarm flash,
central locking flash



Hazard warning lights

The “hazard warning lights on” function is sent directly from the hazard warning light switch to the onboard power supply control unit. This information is not related to the status of terminal 15.

Crash warning lights

The hazard warning lights are switched on automatically when the airbag control unit recognises a crash.

Emergency stop warning lights

The hazard warning lights are switched on in an emergency braking situation (deceleration $> 7 \text{ m/s}^2$ longer than 700 ms) or when the ABS is active for more than two seconds.

This function needs to be activated in the onboard power supply control unit using a VAS tester.

Turn signals

This function is realised in the onboard power supply control unit and by the steering column electronics control unit. It is activated with the turn signal switch.

Lane change flash

If the turn signal switch is pressed for less than 1 second, the indicators will flash three times. Pressing the turn signal switch in the same direction for less than one second will add three more flashes.

The function can be activated with the customisation options or the VAS tester.

Anti-theft alarm and central lock flash

These flash functions are requested by the convenience system central control unit from the onboard power supply control unit via the CAN data bus when the corresponding function is active.

Onboard Power Supply

Exterior lights functional diagram

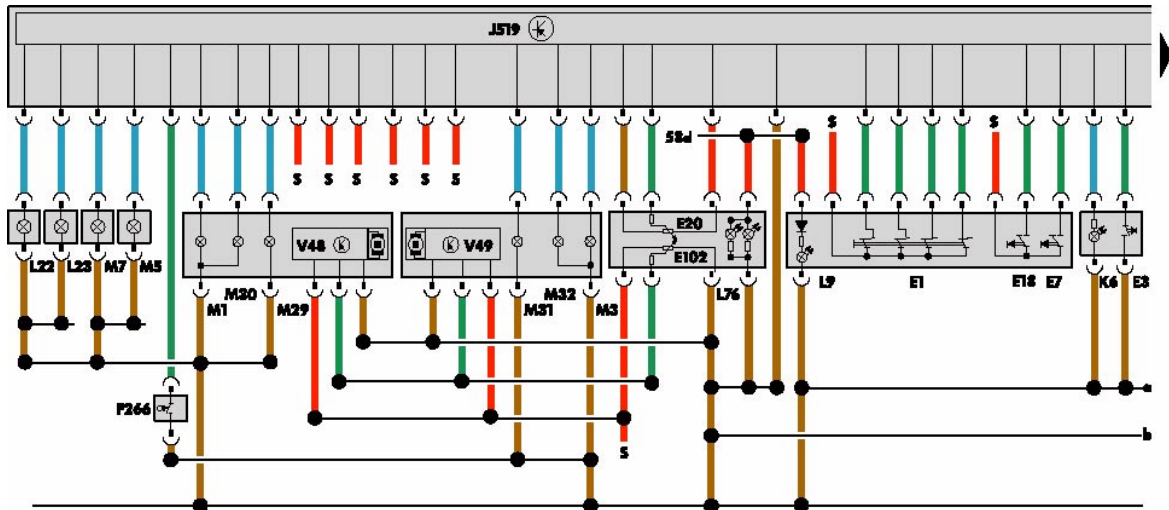

S340_021

Legend

- | | | | |
|------|--|------|---|
| D1 | Immobilizer reading unit | K1 | Main beam warning lamp |
| E1 | Light switch | K4 | Side light warning lamp |
| E2 | Turn signal switch | K6 | Hazard warning light system warning lamp |
| E3 | Hazard warning light switch | K13 | Rear fog light warning lamp |
| E4 | Headlight dipper/flasher switch | K18 | Trailer operation warning lamp |
| E7 | Fog light switch | K65 | Left turn signal warning lamp |
| E18 | Rear fog light switch | K94 | Right turn signal warning lamp |
| E20 | Switches and instruments illumination regulator | K170 | Bulb failure warning lamp |
| E22 | Intermittent wiper switch | L9 | Light switch illumination bulb |
| E34 | Rear wiper switch | L22 | Left fog light bulb |
| E38 | Intermittent wiper regulator | L23 | Right fog light bulb |
| E44 | Washer pump switch
(automatic wash/wipe and
headlight washer system) | L46 | Rear fog light bulb |
| E102 | Headlight range control regulator | L76 | Button illumination bulb |
| E415 | Entry and start authorisation switch | L131 | Exterior mirror turn signal bulb,
driver's side |
| F | Brake light switch | L132 | Exterior mirror turn signal bulb,
front passenger side |
| F4 | Reversing light switch | M1 | Left side light bulb |
| F266 | Bonnet contact switch | M2 | Right tail light bulb |
| J285 | Control unit with display in dash panel insert | M3 | Right side light bulb |
| J362 | Immobilizer control unit | M4 | Left tail light bulb |
| J386 | Driver door control unit | M5 | Front left turn signal bulb |
| J387 | Front passenger door control unit | M6 | Rear left turn signal bulb |
| J393 | Convenience system central control unit | M7 | Front right turn signal bulb |
| J519 | Onboard supply control unit | M8 | Rear right turn signal bulb |
| J527 | Steering column electronics control unit | M9 | Left brake light bulb |
| J533 | Data bus diagnostic interface | M10 | Right brake light bulb |
| J764 | Electronic steering column lock control unit | | |

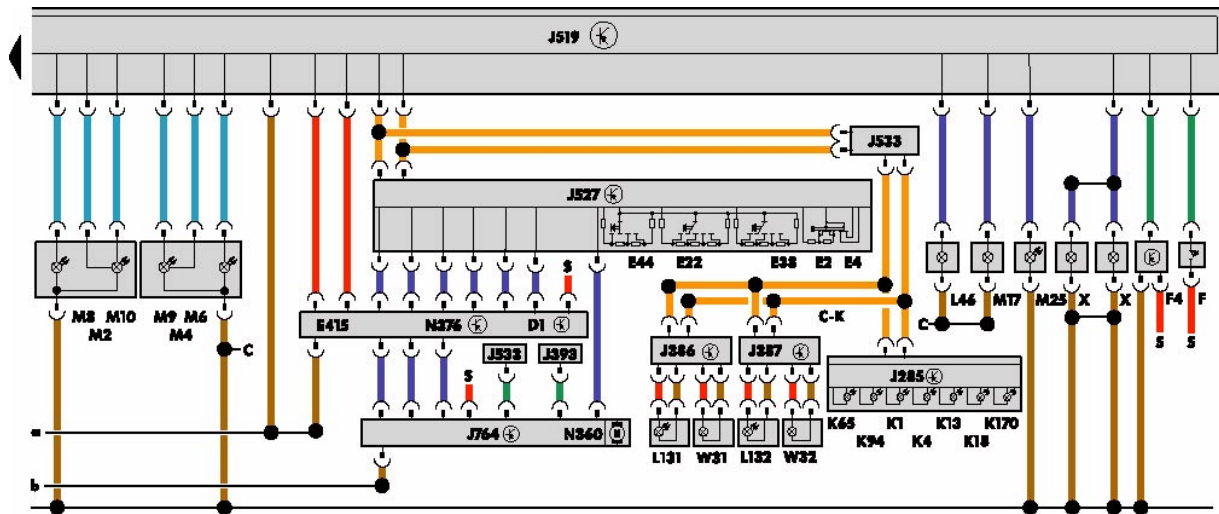

S340_069



- M17 Right reversing light bulb
- M25 High level brake light bulb
- M29 Left dipped beam bulb
- M30 Left main beam bulb
- M31 Right dipped beam bulb
- M32 Right main beam bulb
- N360 Steering column lock control element
- N376 Ignition key withdrawal lock solenoid
- S Fuse
- V48 Left headlight range control motor
- V49 Right headlight range control motor
- W31 Front left entry light
- W32 Front right entry light
- X Number plate light

- Input signal
- Output signal
- Positive
- Earth
- Data bus

Onboard Power Supply

Automatic headlight control

Dusk function

If light switch E1 is set to “automatic headlight control”, the rain and light detector sensor G397 automatically measures the light, e.g. when entering a tunnel, and sends a signal to the onboard power supply control unit to automatically switch on the driving lights.

Legend

- E1 Light switch
- E415 Entry and start authorisation switch
- G397 Rain and light sensor
- J519 Onboard supply control unit
- L123 Left dipped beam bulb
- L124 Right dipped beam bulb
- L125 Left main beam bulb
- L126 Right main beam bulb

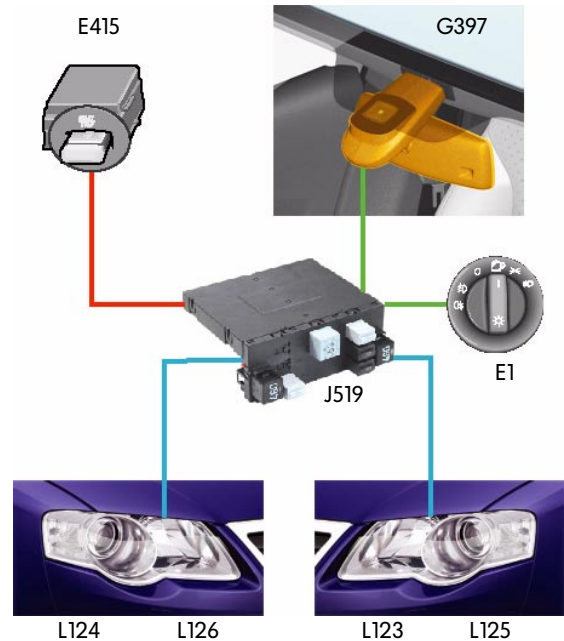

S340_067

Motorway function

The motorway function switches the driving lights on when the car travels faster than 140 km/h for over 10 seconds. They are switched off again when the car travels slower than 65 km/h for longer than 150 seconds. The function is activated when the light switch is set to “automatic headlight control”.



S340_022

Rain function

The rain function switches the driving lights on when the front wipers are active for longer than 5 seconds and the light switch is set to “automatic headlight control”. The driving lights are switched off again when there is no wipe procedure for longer than 255 seconds.



5 Sec.
S340_023

Vehicle lights

Emergency light mode

If the onboard power supply control unit is not capable of controlling the car lights due to a processor malfunction, an additional piece of hardware will take over the following lights:

- Brake light
- Side light
- Dipped beam

Light functions

The following lights have additional functions:



Lights	Additional functions
Rear left and right brake lights	Dimmed switch on as tail light dimmed to 10%
Rear left and right indicator	Dimmed switch on as tail light dimmed to 15%

Light switch delay

The delay prevents the headlights being switched on briefly in the “automatic headlight control” position when you quickly turn the switch from the “off” position to the “side lights” or “headlights” position.

From/to	Off		Automatic headlight control		Side light		Driving lights	
	“Light Sensor” signal		“Light Sensor” signal		“Light Sensor” signal		“Light Sensor” signal	
	“Lights on” (ms)	“Lights off” (ms)	“Lights on” (ms)	“Lights off” (ms)	“Lights on” (ms)	“Lights off” (ms)	“Lights on” (ms)	“Lights off” (ms)
Off			500	0	0	0	0	0
Automatic headlight control	0	0			600	0	0	0
Side light	0	0	500	0			0	0
Driving lights	0	0	0	0	600	600		

Onboard Power Supply

Data Bus Diagnostic Interface J533

Function

Due to the high proportion of networked functions, large quantities of data have to be transferred.

To ensure trouble-free data exchange, several data bus systems are required to exchange data between each other.

The data bus diagnostic interface links these data buses as a gateway interface and allows data transfer.



Location

The data bus diagnostic interface is on the left under the dash panel, above the accelerator pedals.

Master functions

The data bus diagnostic interface J533 takes over the master functions for terminal 15 run-on on the powertrain CAN data bus as well as the control logic for sleep and wake-up mode of the data bus systems.



S340_028



For more information on the data bus diagnostic interface, see SSP 307 "The Touran – Electrical System".

Transport mode

The car battery can be discharged during long transportation and standing times due to no-load currents.

Transport mode is activated to keep power consumption as low as possible. Control unit with display in dash panel insert J285 indicates that transport mode is active.

While transport mode is active, the car can be started and can be driven normally. The following convenience and infotainment consumers are deactivated:

- Central locking
- Window regulators
- Radio
- Multifunction steering wheel
- Remote control
- Interior monitoring
- Receiver for auxiliary heater remote start
- Inclination sensor
- Save LED in the door
- Interior lights after 30 seconds active
- Seat memory
- Air conditioning



Deactivate transport mode

Transport mode can only be switched off with the VAS diagnostic testers via the vehicle self-diagnosis (collection services).

It is automatically disabled after a distance > 50 km.

Activate transport mode

Transport mode can only be switched on with the VAS diagnostic testers via the vehicle self-diagnosis (collection services).

It can only be activated within the first 150 km.



S340_029

Onboard Power Supply

Control Unit with Display in Dash Panel Insert J285

Function

The control unit with display in dash panel insert receives its information for the display unit and warning lights from the various control units via the data bus diagnostic interface J533 and via the combi CAN data bus.

External sensor signals still reach the control unit in the dash panel insert from the following sensors via discrete wiring:

- F1 Oil pressure switch
- F9 Handbrake warning switch
- F34 Brake fluid level warning contact
- G17 Ambient temperature sensor
- G32 Coolant shortage indicator sender
- G33 Windscreen washer fluid level sender
- G34 Brake pad wear sender
- G266 Oil level and oil temperature sender
- J538 Fuel pump control unit

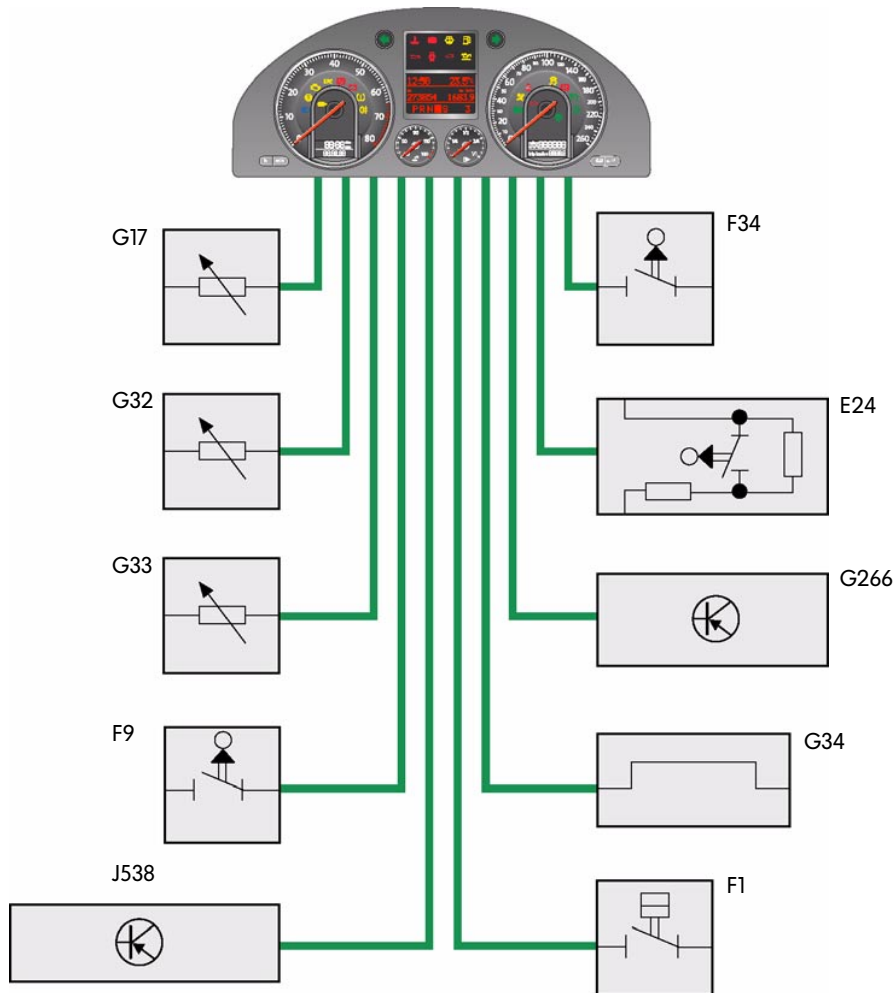

S340_030

Variants

The gauges in the display in the dash panel insert Y24 are divided into three versions.

Lowline version

The lowline version has eight LED warning lights (E) and a semi-dot liquid crystal display (LCD) (F).

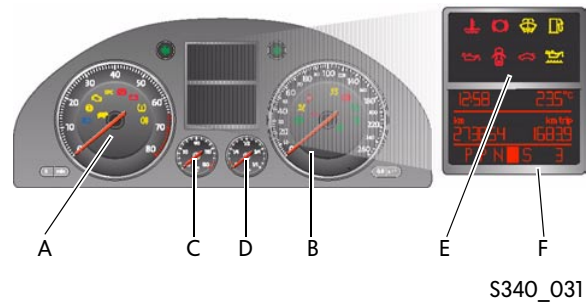

S340_031

E

Midline version

The midline version has eight LED warning lamps (E), a mini-dot display (F), a semi-dot LCD in the speedometer (O) and in the rev counter (N).



S340_032

F

Highline version

The midline version has a dot-matrix display (K), a semi-dot LCD in the speedometer (O) and in the rev counter (N).



S340_033

K

Common equipment

All versions have:

- Rev counter (A) G5
- Speedometer (B) G21
- Coolant temperature gauge (C) G3
- Fuel gauge (D) G1



















Onboard Power Supply

Equipped with warning lamps



Symbol	Warning lamp	Lowline	Midline	Highline	Warning text or warning
	Airbag	X	X	X	Airbag fault Airbag Belt tensioner deactivated
	ABS (anti-lock brake system)	X	X	X	ABS
	Brake pad wear	X	X	Pictogram	Check brake pad
	Brake fluid low	X	X	X	Stop brake fluid Owner's manual
	Preheat (diesel engines)	X	X	X	Engine fault Workshop! Emissions Workshop!
	or Electronic Power Control	X	X	X	Engine fault Workshop! Emissions Workshop!
	Dynamic oil pressure warning	Flashing	Flashing	Flashing Pictogram	Stop Oil pressure Engine off Owner's manual 3 x warning buzzer
	Diesel particle filter	X	X	Pictogram	
	Power steering Electronic Power Steering	X	X	X	Steering lock fault! Lock steering! Move steering! Steering lock! Workshop!
	Electronic brake pressure distribution	X	X	X	3 x warning buzzer
	Parking brake / electromechanical parking brake	X	X	X	Handbrake on Release parking brake by hand! Depress brake pedal!
	Electromechanical parking brake Warning lamp	X	X	X	Parking brake fault! Owner's manual!
	ESP TCS	X	X	X	
	Left-hand indicator	X	X	X	Acoustic signal
	Right-hand indicator	X	X	X	Acoustic signal
	Trailer turn signals	X	X	X	
	Main beam	X	X	X	
	Cruise control	X	X	X	

Icon	Warning lamp	Lowline	Midline	Highline	Warning text or warning
	Bulb failure		X	X	e.g. Front left dipped beam defective! Constantly illuminated: Faulty bulb Flashing: HRC or AFS faulty
	Boot lid	X	X	Pictogram	e.g. Boot lid open! 1 x warning buzzer at speed of > 6 km/h
	Door open	X	X	Pictogram	Driver's door open! Passenger door open! Rear left door open! Rear right door open! 1 x warning buzzer at speed of > 6 km/h
	Fuel reserve	X	X	Pictogram	Please refuel 1 x warning buzzer
	Coolant low or overheating	X	X	Pictogram	Stop! Check coolant Owner's manual 3 x warning buzzer
	Alternator	X	X	X	
	Engine check EOBD	X	X	X	Engine fault Workshop! Emissions Workshop!
	Bonnet open	X	X	Pictogram	Door warning! Hood! 1 x warning buzzer when v > 6 km/h
	Rear fog lights	X	X	X	
	Oil level	X	X	Pictogram	Check oil level Oil sensor Workshop!
	Tyre pressure monitoring	X	X	X	1 x warning buzzer
	Shift lock	X	X	X	
	Seat belt	X	X	X	Please fasten seatbelt Gong
	Day driving lights	X	X	X	
	Fuel cap open	X	X	X	
	Wash fluid low	X	X	X	Top up wash fluid 1 x warning buzzer



Onboard Power Supply

Convenience System Central Control Unit J393

Location

The convenience system central control unit is located under the dash panel, on the right behind the glove compartment.

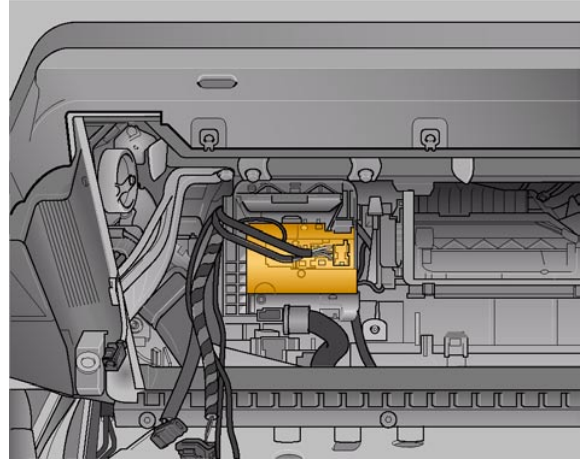

S340_034

Tasks

The convenience system central control unit activates and controls the following functions:

- Central locking control unit
- Activation of rear door control units
- Activation of the fuel tank flap release
- Activation of the boot lid release
- Activation of the anti-theft alarm via LIN bus
- Activation of the tyre pressure monitor
- Activation of the immobilizer
- Activation of the entry and start authorisation system.

In the Passat 2006, the tyre pressure monitoring (via tyre pressure sensors and tyre pressure monitor aerials), immobilizer control unit J362 and entry and start authorisation control unit J518 functions are combined in the convenience system central control unit for the first time.

Furthermore the convenience system central control unit is the master control unit in the LIN anti-theft alarm data bus. The anti-theft alarm system includes the interior monitoring sensor G273, the intelligent anti-theft alarm system horn H12 and the vehicle inclination sensor G384.

Central locking

The convenience system central control unit controls all central locking functions. The central locking system includes the doors, the boot lid and the tank filler flap.

There are three locking states.

Unlocked	The doors can be opened from the inside and outside.
Locked	The doors can only be opened from the inside by pulling the door handle once.
Safe	The doors cannot be opened either from the inside or the outside.



Locking points

It is operated by the emergency lock cylinder in the driver's door, the interior locking button and the remote control on the car key.

The motors for the central locking in the driver's and passenger door are controlled by the respective door control units. The control of the rear doors, the boot lid and the tank filler flap is handled by the convenience system central control unit.

Operating central locking

If the vehicle is locked via the interior locking button, the LED integrated in the button will illuminate. The doors can be opened from the inside by pulling the door handle once.

When individual door opening is activated, opening the car mechanically with the car key only unlocks the driver's door. Turning the key twice also only operates the door control unit on the driver's side.

Pressing the OPEN or CLOSE button more than 200 times outside the reception range of the convenience system central control unit blocks the remote control unit. The remote control needs to be re-activated by pressing the OPEN button and then unlocking the car with the car key (within one minute).

Onboard Power Supply

Immobilizer IV

What does the immobilizer IV comprise?

The immobilizer IV is not a separate control unit, but a function.

It includes:

- Storage of all theft-related features of the control units in the FAZIT central database in Wolfsburg.
- Communication of the convenience system central control unit, in which the immobilizer is integrated, with the other components involved.
- Encryption of the data communication between the individual control units.



Central FAZIT database

The central FAZIT database at Volkswagen in Wolfsburg is an essential component of the immobilizer IV.

FAZIT stands for “Fahrzeugauskunft- und zentrales Identifikations-Tool” (Vehicle Information and Central Identification Tool). All theft-related data from the control units that are integrated in the “Immobilizer” function are stored in this database.

It is not possible to adapt the control units used without an online connection to FAZIT.

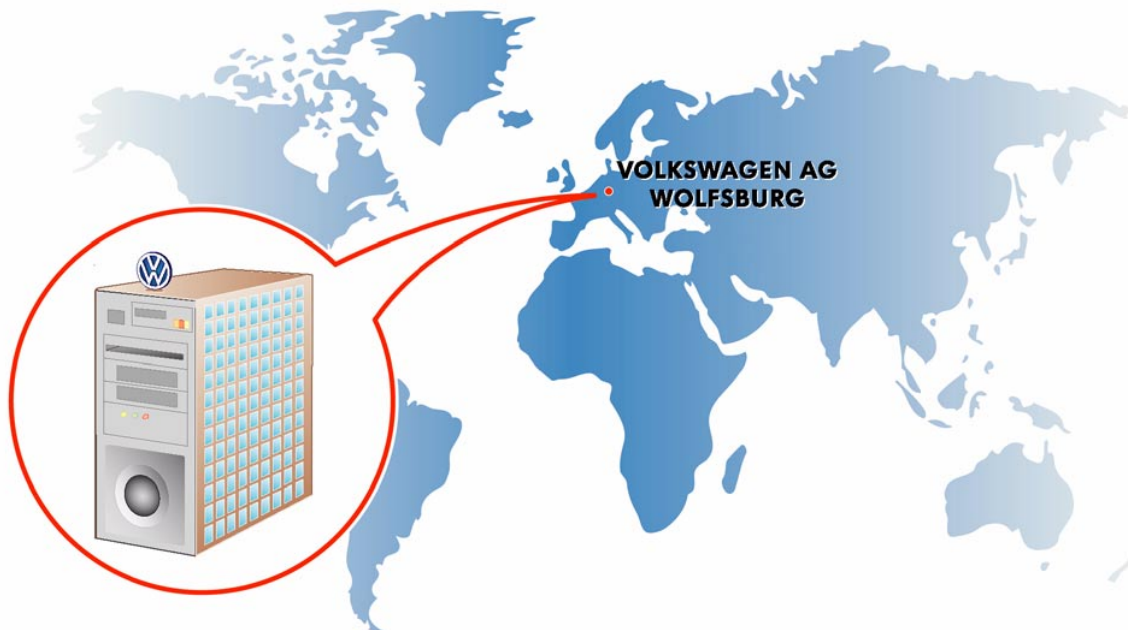

S340_036

Data Transfer

- Only an online query by the diagnostic tester transfers the data safely, quickly and reliably in the car.
- A PIN query of the immobilizer components by fax or prior enabling of the components is not possible.
- All components involved in the immobilizer have to be taught online.
- All car keys (including replacements) are already pre-coded at the factory for a specific car and can only be taught for this vehicle.

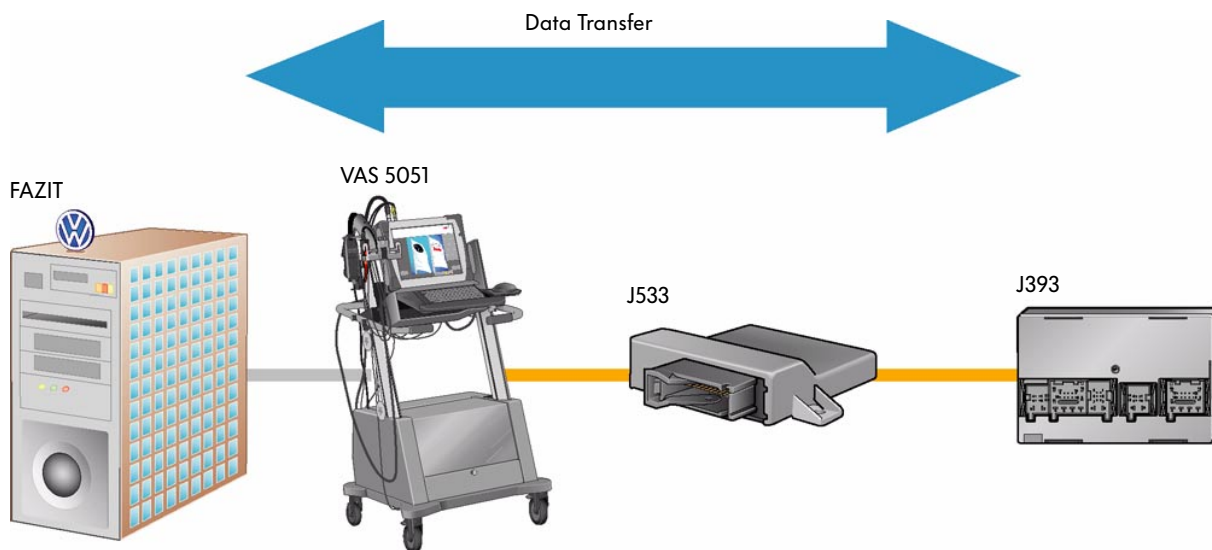

S340_037

Legend

J393 Convenience system central control unit

J533 Data bus diagnostic interface

Onboard Power Supply

Immobilizer components

Convenience system central control unit J393

The immobilizer function is integrated in the convenience system central control unit. The control unit needs to be adjusted online after a replacement.

Entry and start authorisation switch (E415)

The entry and start authorisation switch contains the reader coil for reading the transponder in the car key. The switch for entry and start authorisation does not need to be adjusted after changing.

Electronic steering column lock control unit J764

The approval for locking and unlocking the steering column is provided via the "Immobilizer" function in the convenience system central control unit. The control unit can only be replaced and adjusted together with the convenience system central control unit.

Engine control unit J623

The engine control unit is part of the "Immobilizer" function. Authorisation via the CAN data bus from the convenience system central control unit is required for continuous running of the engine. This control unit needs to be adjusted online after a replacement.

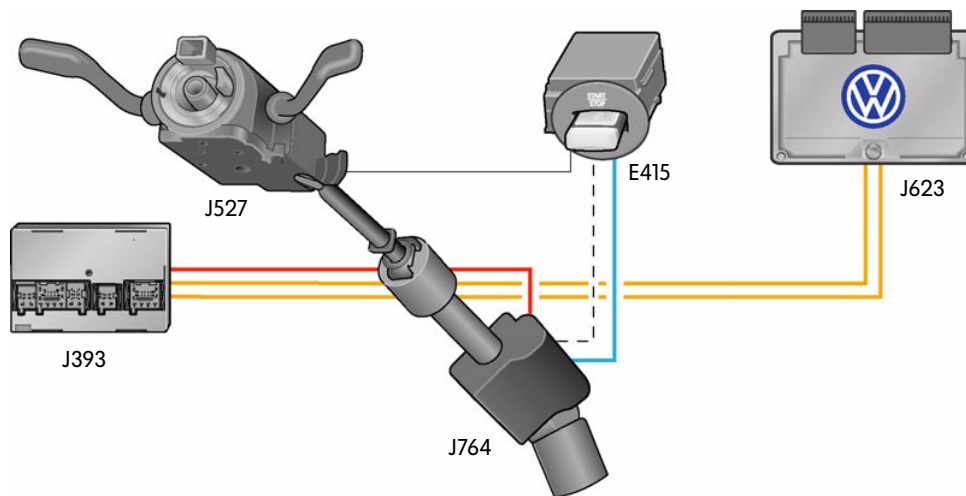

S340_038

Legend

E415 Entry and start authorisation switch
J393 Convenience system central control unit
J527 Steering column electronics control unit
J623 Engine control unit
J764 Electronic steering column lock control unit

— Reader coil line
— Powertrain CAN data bus
- - - S contact
— Coded voltage supply signal

Replacement of control units

Control units that are involved in the "Immobilizer" function can only be replaced with an online connection to the FAZIT database.

Convenience system central control unit J393

- Request data via online connection
- Data transfer via VAS tester
- Download data into control unit
- Teach control unit
- Teach car key

Engine control unit J623

- Request data via online connection
- Data transfer via VAS tester
- Download data into control unit
- Data exchange between control unit and FAZIT
- Teach car key



Electronic steering column lock control unit J764 and convenience system central control unit J393

- Request data via online connection
- Data transfer via VAS tester
- Download data into control unit
- Data exchange between control units and FAZIT
- Teach car key

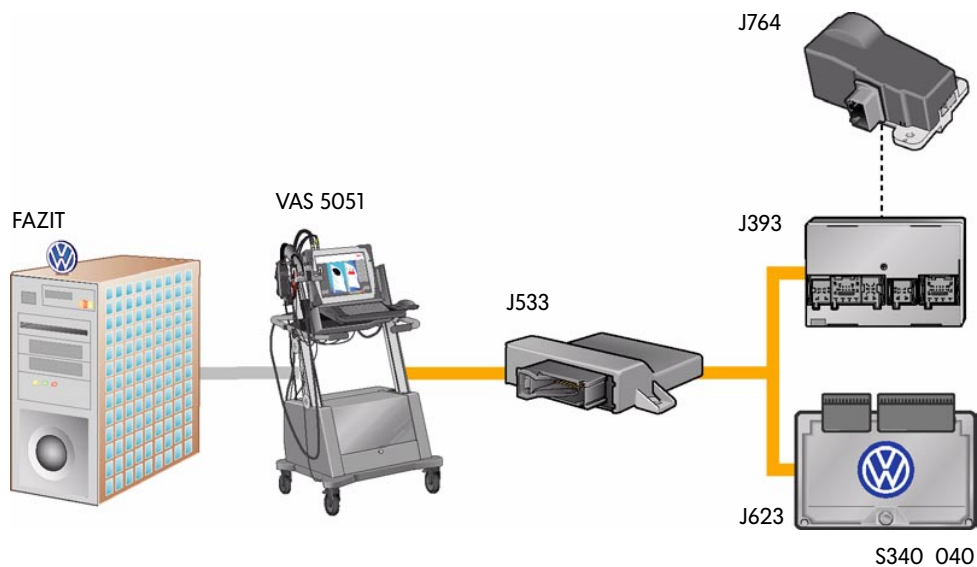

Legend

J393 Convenience system central control unit
J527 Steering column electronics control unit
J533 Data bus diagnostic interface

J623 Engine control unit
J764 Electronic steering column lock control unit

Onboard Power Supply

Start-Stop System

Entry and start authorisation switch

The entry and start authorisation switch is part of the driving authorisation system. It is used as a mechanical holder for the ignition key, converts the push movement of the ignition key into electrical signals and picks up the reader coil for electronic identification of the ignition key.

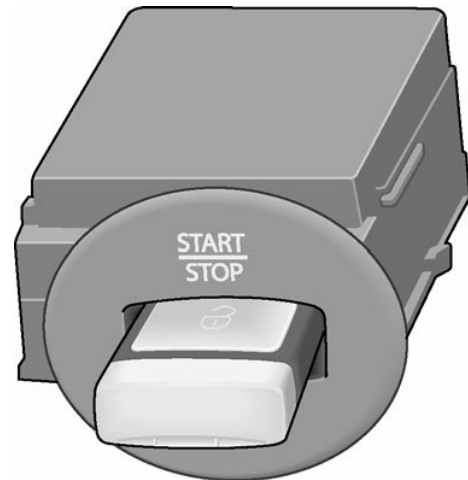

S340_044

Key ignition

The ignition key does not have a key bit as the car is started with a pushing movement for the first time, not by turning.



S340_042

Emergency key

The emergency key is used to open the driver's door mechanically if you cannot open it with the remote control.

It is inserted in the ignition key. Also the key ring holder is attached to it. It can be used when the emergency key is in the second notch.



S340_043

Key positions

The various terminal voltages (terminal S, terminal 15) are activated and the start procedure is initiated by pushing the ignition key into the entry and start authorisation switch.



S340_041

Switch positions

The following switch positions can be set by pushing the ignition key:

- P₀ Off
- P₁ S contact on
- P₂ Terminal 15 on
- P₃ Terminal 15 drive
(the ignition key automatically moves to this position after starting)
- P₄ Terminal 50 on

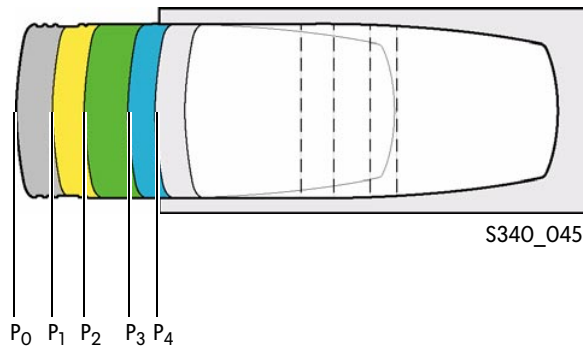

S340_045



Functional Diagram

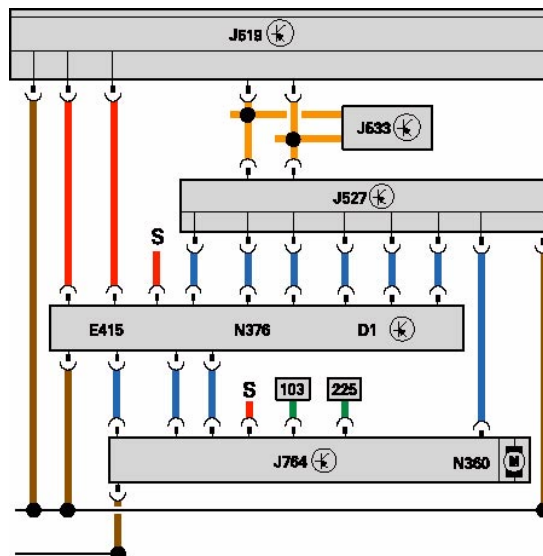

S340_046

Legend

- D1 Immobilizer reading unit
- D2 Immobilizer reader coil
- E415 Entry and start authorisation switch
- J362 Immobilizer control unit
- J519 Onboard supply control unit
- J527 Steering column electronics control unit
- J533 Data bus diagnostic interface
- J764 Electronic steering column lock control unit
- N376 Ignition lock withdrawal solenoid lock

Onboard Power Supply

Electronic Steering Column Lock Control Unit

Control unit

The electronic steering column lock is supplied with power by the convenience central control unit J393. Locking and unlocking as well as diagnosis is controlled with the convenience system central control unit via a serial data bus connection.

To take the increased safety requirements into account, the electronic steering column lock release needs to be authorised by three separate control units.

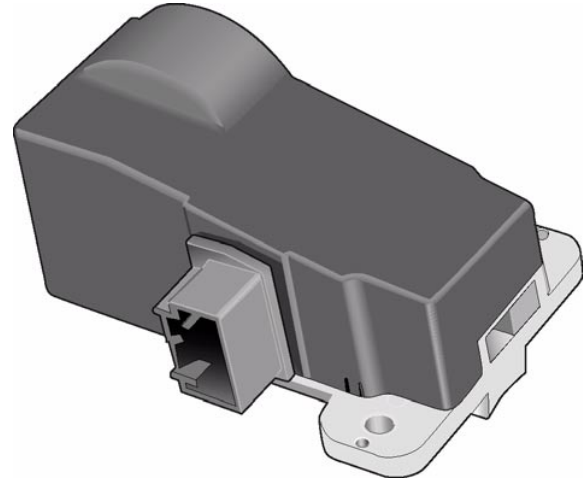

S340_047



Lock/unlock

The following conditions need to be met:

- An authorised key needs to be recognised by the immobilizer.
- Data bus diagnostic interface J533 (speed = 0 km/h; revs = 0 rpm)
- Steering column electronics control unit J527 (terminal 15 off; speed = 0 km/h)
- Convenience system central control unit J393 (terminal 15 off; CAN signals from J533 and J527 OK)
- Entry and start authorisation switch E415 (S contact off, terminal 15 off)
- Electronic steering column lock control unit J764 (checks whether both speed signals from J533 and J527 are OK)



The electronic steering column only unlocks when an authorised key is recognised by the immobilizer. Terminals 15 and 50 are only activated once the electronic steering column lock has been released.

Functional Diagram

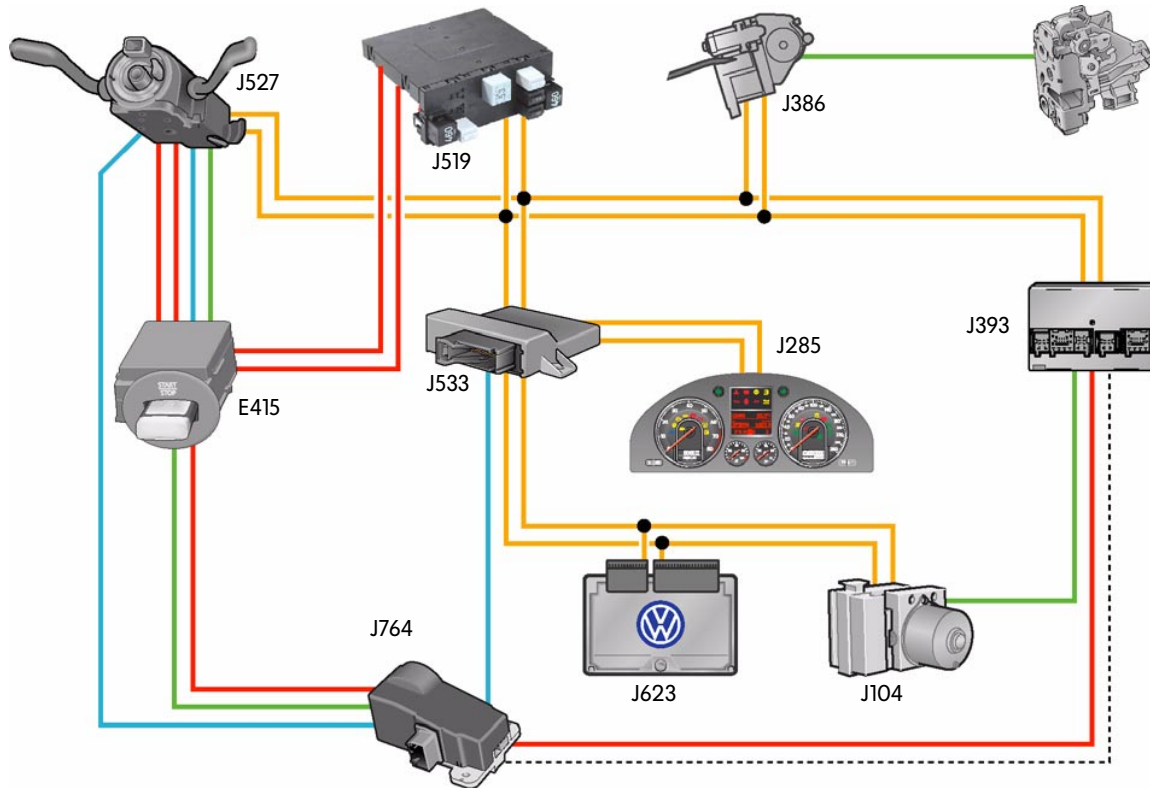

S340_048

Legend

- E415 Entry and start authorisation switch
- J104 ABS control unit
- J285 Control unit with display in dash panel insert
- J386 Driver door control unit
- J393 Convenience system central control unit
- J519 Onboard supply control unit
- J527 Steering column electronics control unit
- J533 Data bus diagnostic interface
- J623 Engine control unit
- J764 Electronic steering column lock control unit

- — CAN data bus
- Output signal
- Input signal
- Plus
- - - - - Serial data bus

Convenience and safety electronics

Cornering Light System (Advanced Frontlighting System)

A cornering light system is optionally available for the Passat 2006.

Dynamic cornering lights

The dynamic cornering lights are adjusted to the steering angle during cornering and therefore guarantee optimum road illumination in all driving situations.



S340_024

Static cornering lights

The static cornering light is particularly useful when you turn off at crossroads and into side roads. An additional bulb in the headlights is switched on for this.

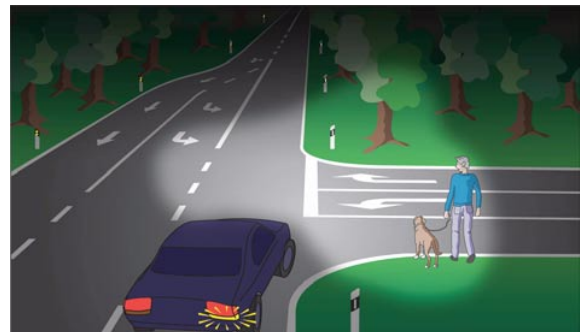

S340_025



You will find further information on the cornering lights in SSP 335 "Cornering Light System"

Dynamic cornering light operation

The dipped beam bulb module is swivelled horizontally by an integrated electric motor.

Swivelling angle

The swivelling angle is approx. 15 degrees for the outside headlight and approx. 7.5 degrees for the inside headlight in the curve.

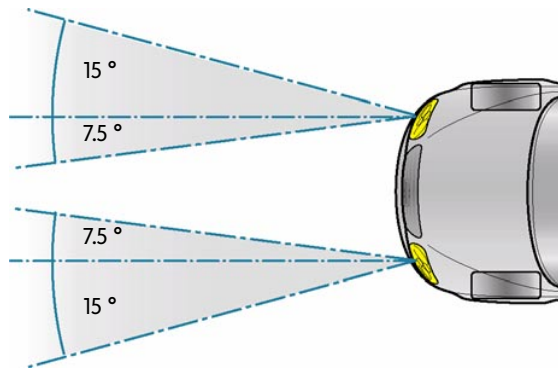

S340_026

Illumination

Curves are illuminated better due to the varying swivelling angles. The maximum possible illumination is reached by the headlight on the inside of the curve swivelling in twice as far as the headlight on the outside of the curve.

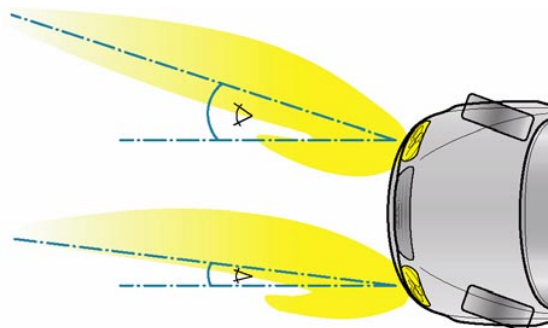

S340_027



At driving speeds under 10km/h, the bulb modules are not swivelled. Over 10km/h, the swivelling angle is basically dependent on the curve radius. The legal requirements stipulating that the headlights may be not swivelled while the vehicle is stationary are therefore fulfilled. Also, the headlights are swivelled slightly when the vehicle accelerates from a standstill and the steering angle remains constant.

Convenience and safety electronics

Customisation

Customisation options allow customers to make their own settings for convenience and infotainment functions.

The specific settings for the different equipment functions are made using a control element and a display.

The system is operated using the lever on the steering wheel and the menus are selected using the display in the dash panel insert Y24.

The settings you select are stored in the control unit that is responsible for control of the respective function.

The necessary information is transferred between the control unit in the dash panel insert and the respective control units via the CAN data bus.

Control units involved in customisation

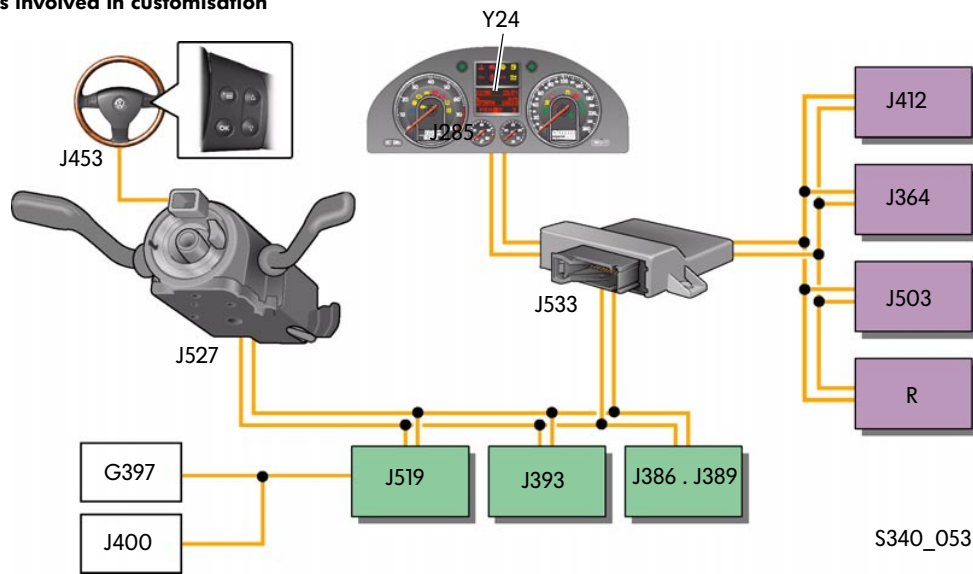

Legend

G397 Rain and light sensor
 R Radio
 J285 Control unit with display in dash panel insert
 J364 Auxiliary heater control unit
 J386..J389 Door control units
 J393 Convenience system central control unit
 J400 Wiper motor control unit
 J412 Mobile telephone operating electronics control unit

J453 Multifunction steering wheel control unit
 J503 Control unit with display for radio and navigation
 J519 Onboard supply control unit
 J527 Steering column electronics control unit
 J533 Data bus diagnostic interface
 Y24 Display in dash panel insert



For example: Menu guide

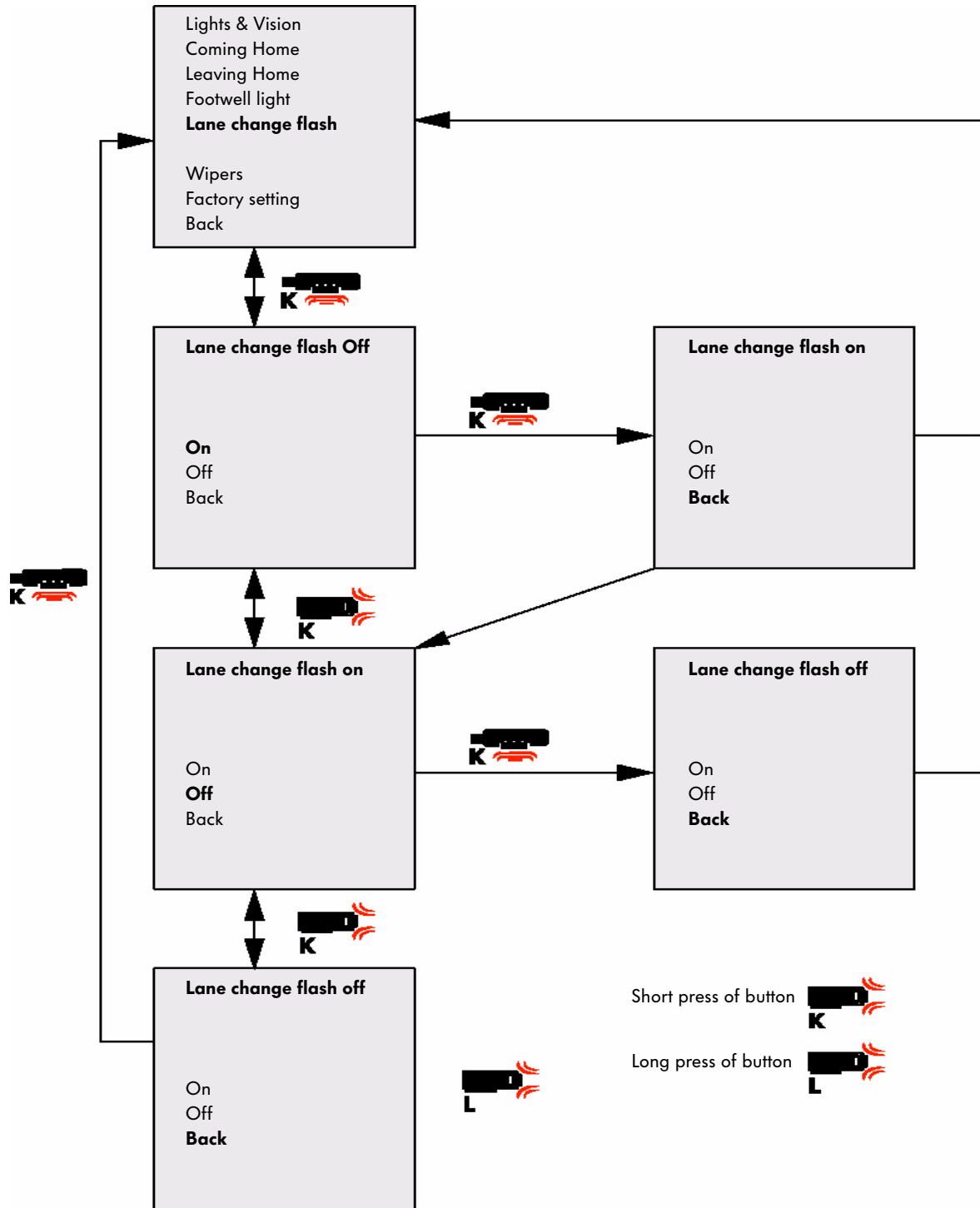

S340_054

Convenience and Safety Electronics

Parking Aid

The parking aid supports the driver when manoeuvring and parking. It is based on the familiar 8-channel ultrasound technology.

Parking aid control unit J446

The parking aid control unit J446 is located in the boot at the rear right.

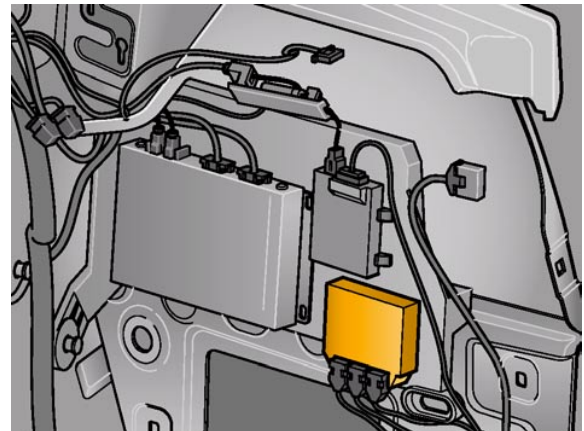

S340_055

Parking aid button E266

The parking aid button is on the right next to the selector lever or gearstick. The parking aid is activated when you press the button or select reverse gear.

It is switched off when you press the button again or automatically at a speed > 15 km/h.

The LED in the button turns yellow when the parking aid is active. If the LED is flashing, a fault has been detected.



S340_056

Parking aid button

Parking aid sender

The senders are mounted in the rear and front bumpers as well as the radiator grille.

Signal flow diagram

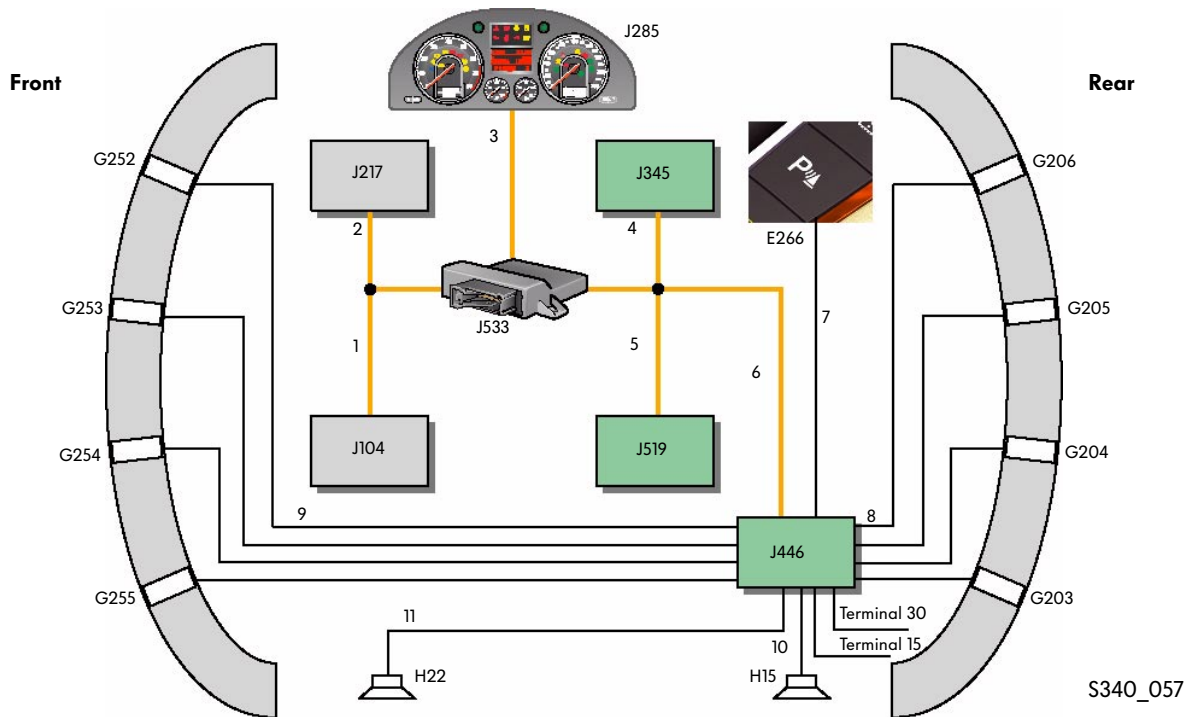

Legend

E266 Parking aid button
 G203 Rear left parking aid sender
 G204 Rear centre left parking aid sender
 G205 Rear centre right parking aid sender
 G206 Rear right parking aid sender
 G252 Front right parking aid sender
 G253 Front centre right parking aid sender
 G254 Front centre left parking aid sender
 G255 Front left parking aid sender
 H15 Rear parking aid warning buzzer
 H22 Front parking aid warning buzzer
 J104 ABS/ESP control unit
 J217 Automatic gearbox control unit
 J285 Control unit with display in dash panel insert
 J345 Trailer detector control unit
 J446 Parking aid control unit
 J519 Onboard supply control unit
 J533 Data bus diagnostic interface

Signal flow

- 1 Wheel speed from J104 to J446 via J533.
- 2 Selector lever position J217 to J446 via J533.
- 3 Vehicle speed from J285 to J446 via J533.
- 4 Trailer detection from J345 to J446
 If a trailer is detected, only the front senders will be active.
- 5 Terminal 15 on and reversing light on from J519 to J446
- 6 Fault detected from J446 to J533
- 7 E266 pressed
- 8 Signals from the rear parking aid senders
- 9 Signals from the front parking aid senders
- 10 Trigger H15
- 11 Trigger H22



Convenience and Safety Electronics

Transformer

The Passat 2006 can be ordered with an optional 230 V/50 Hz electrical socket. A transformer has been installed in the car to produce the alternating voltage. It is permanently connected to the socket. This unit is located in the centre console in place of the cupholder.

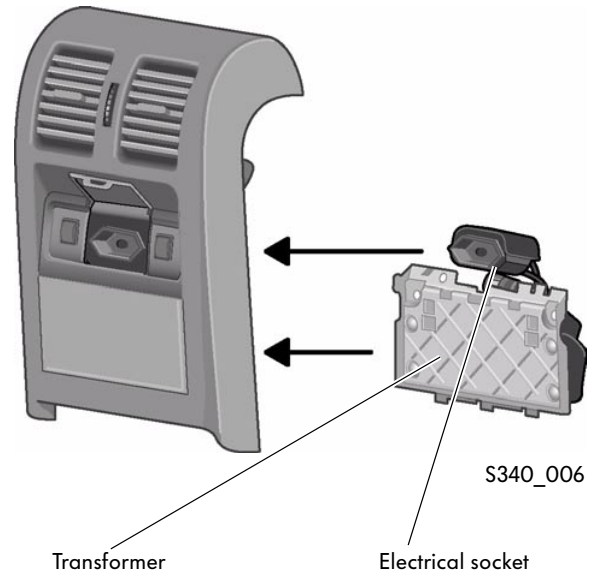

Electrical socket

The 230 V socket does not have an earth connector and can only be operated with a maximum continuous output of 150 W. Approx. 300 W can be supplied as a short peak output (2 min). The socket has a built-in child protection device, which also functions as a switch. A green LED above the socket shows that it is working properly. If this LED flashes red, there is a fault. This can occur when the output exceeds 150 W for a long period (overtemperature cut-off) or the load draw is too high (greater than 300 W).



No repairs may be carried out on 230 Volt systems. Therefore the whole module needs to be replaced when the socket or transformer is faulty.

The socket is only powered when the engine is running (terminal 61). Except for the signal cable from the onboard power supply control unit, the transformer is connected to the onboard power supply control unit with a voltage supply (terminal 30) and an earth point. The alternating voltage stage is electrically isolated.

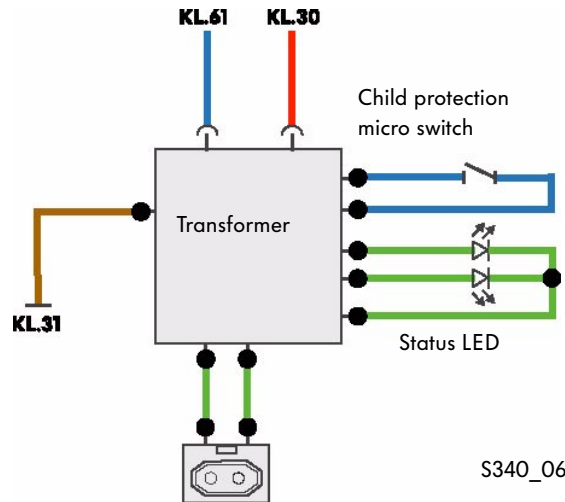

The following appliances can be run with the transformer, for example:

- Notebook power supply 75-110 W
- Games console 40-100 W
- Bulb 25-100 W
- Television ~85 W
- Baby bottle warmer ~80 W
- Battery charger ~50 W
- Mobile phone charger ~30 W
- DVD player ~30 W
- Shaver ~10 W



The following appliances cannot be run with the transformer, for example:

- Hairdryer > 1000 W
- Vacuum cleaner > 800 W
- Coffee machine > 500 W
- Appliances with an earth connection
- Work lights with neon tubes



Wiper Adapter Systems

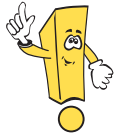

Two new adapter systems are used for the wipers on the Passat 2006 called the side-lock and top-lock systems. Both systems allow you to replace the wiper blades in the parked position and ensure a more stable connection to the wiper arm.

Side-lock adapter system

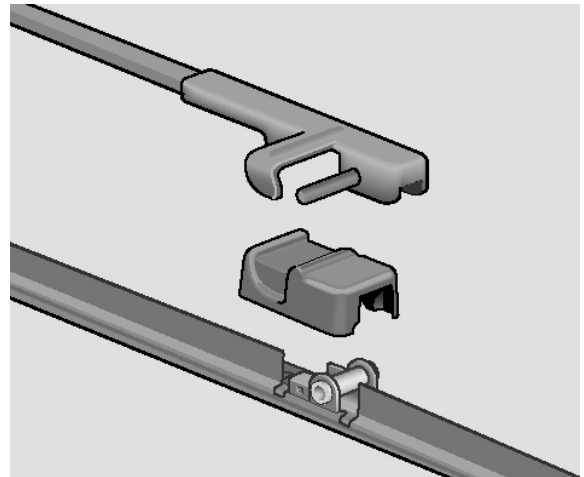

S340_074

Top-lock adapter system

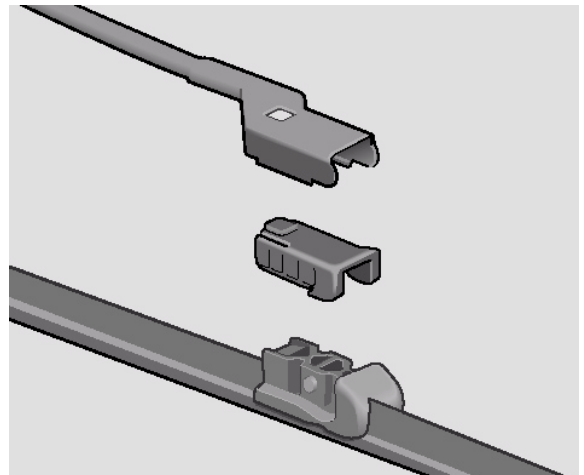

S340_075



Washer Fluid Hose

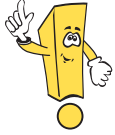

The Passat 2006 features an improved connector system for the washer fluid hose.

Washer fluid hose connector

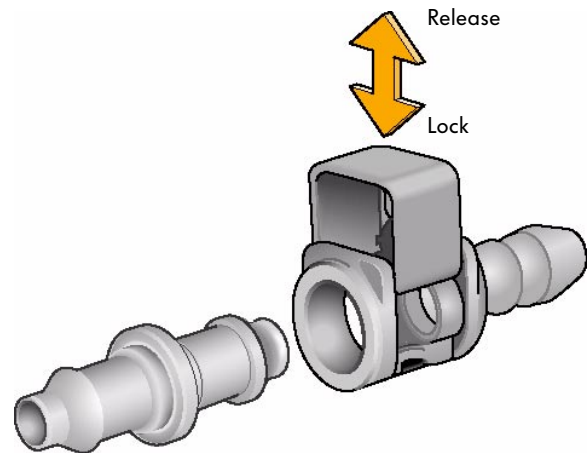

S340_076



Please refer to the ELSA electronic service information system for specific instructions on replacing wiper blades and separating the connectors.



Test Yourself

1. What is the maximum appliance output that can be connected constantly to the 230 V socket?

- a) 100 W
- b) 150 W
- c) 300 W
- d) 150 W, but only for 2 minutes

2. Which functions are not integrated in the new convenience system central control unit?

- a) Immobilizer
- b) Tyre pressure monitoring
- c) Central locking
- d) Transformer

3. Which light systems are used in the new Passat tail lights?

- a) LEDs only
- b) Bulbs only
- c) Bulbs in the side section, LEDs in the boot lid
- d) LEDs in the side section, bulbs in the boot lid



4. Which components have to be adjusted using the FAZIT database?

- a) Convenience system control unit
- b) Electronic steering column lock control unit
- c) Engine control unit
- d) Onboard supply control unit

5. Where is the entry and start authorisation switch?

- a) In the door handle
- b) In the dash panel
- c) In the boot
- d) In the driver's door, next to the window switches

6. How many sensors does the Passat 2006 parking aid system have?

- a) 4 sensors, just at the rear
- b) 6 sensors at the front, 6 sensors at the rear
- c) 4 sensors at the front, 4 sensors at the rear
- d) 6 sensors, just at the rear



Answers: 1 b; 2 d; 3 d; 4 a; b; c; 5 b; 6 c

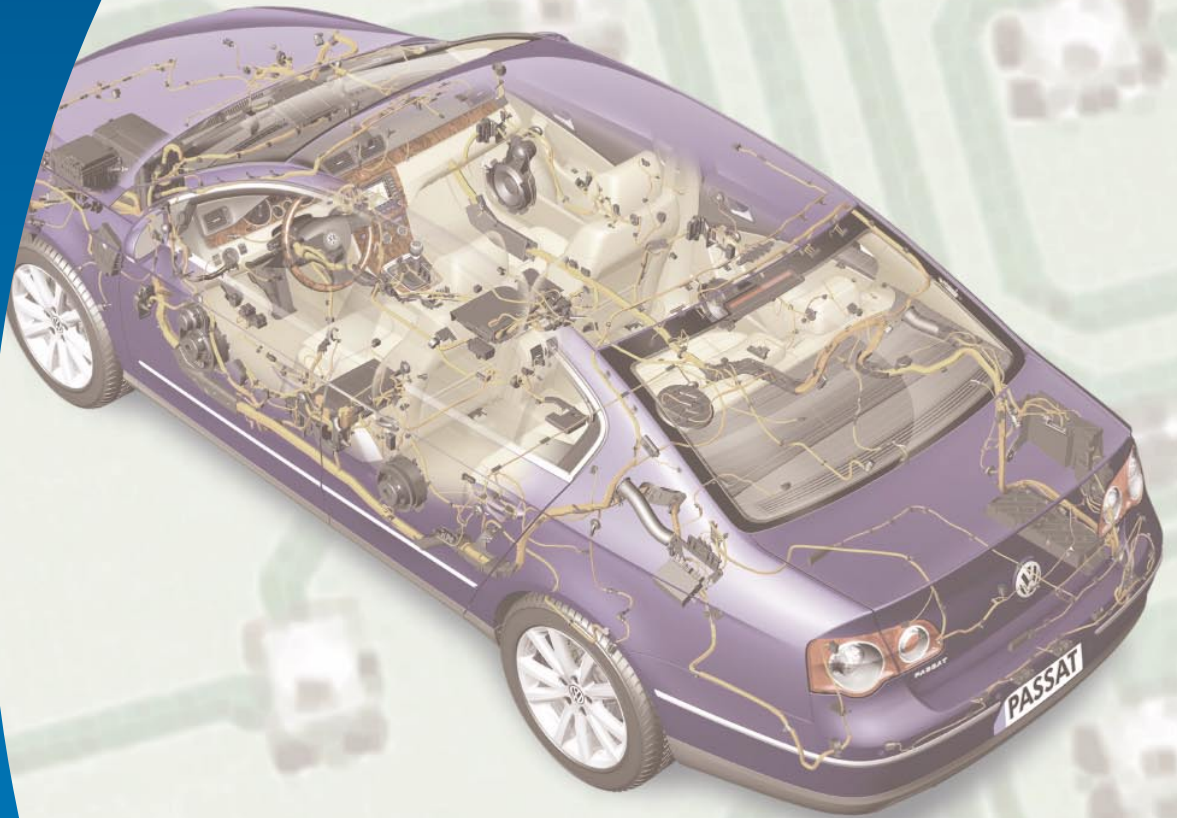

© VOLKSWAGEN AG, Wolfsburg
All rights and rights to make technical alterations reserved.
000.2811.55.20 Technical status 02/2005

Volkswagen AG
Service Training VK-21
Brieffach 1995
38436 Wolfsburg

 This paper was manufactured from pulp that was bleached without the use of chlorine.