

AIR CONDITIONING

Fig 1: Automatic A/C Circuit (1 of 2)

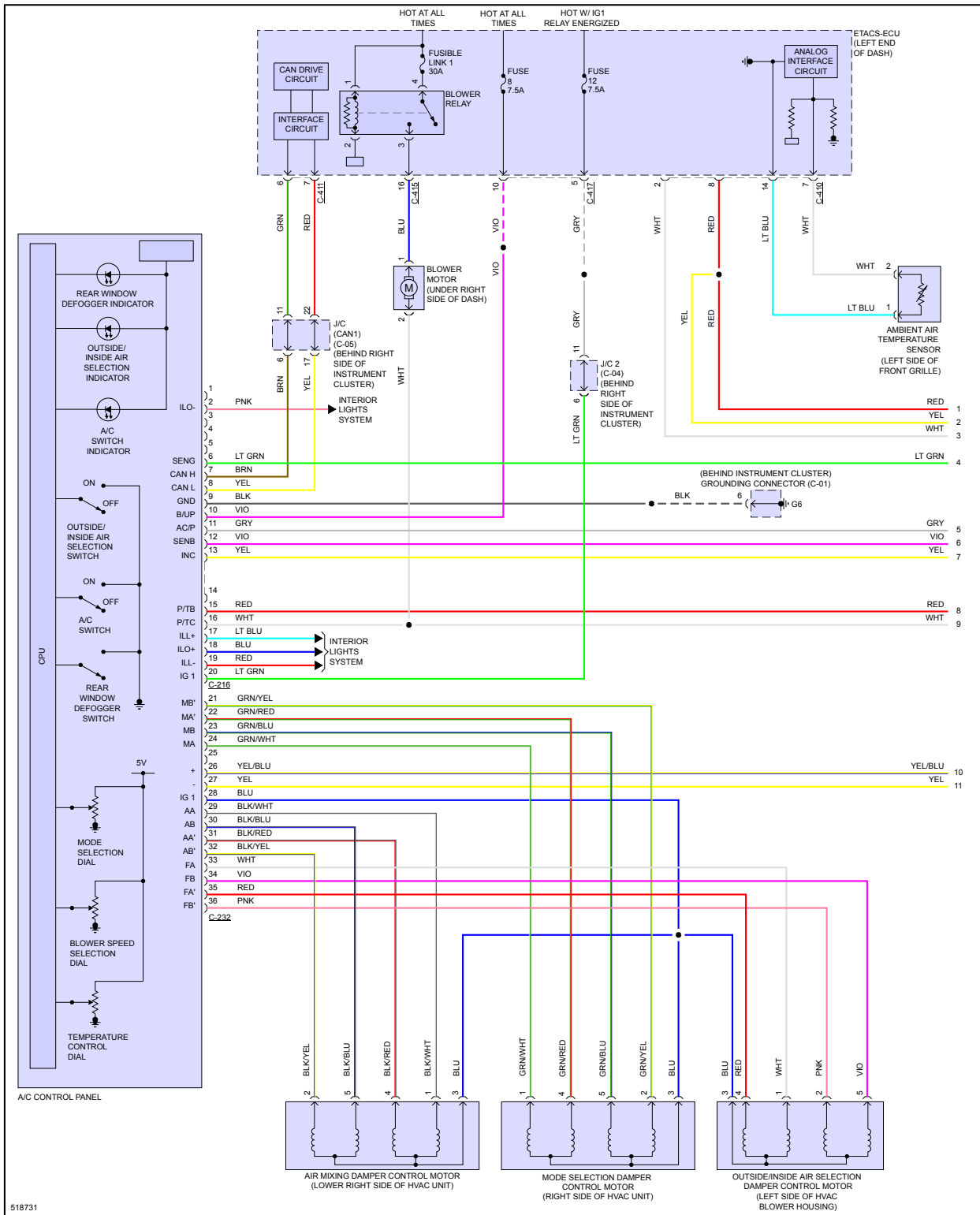
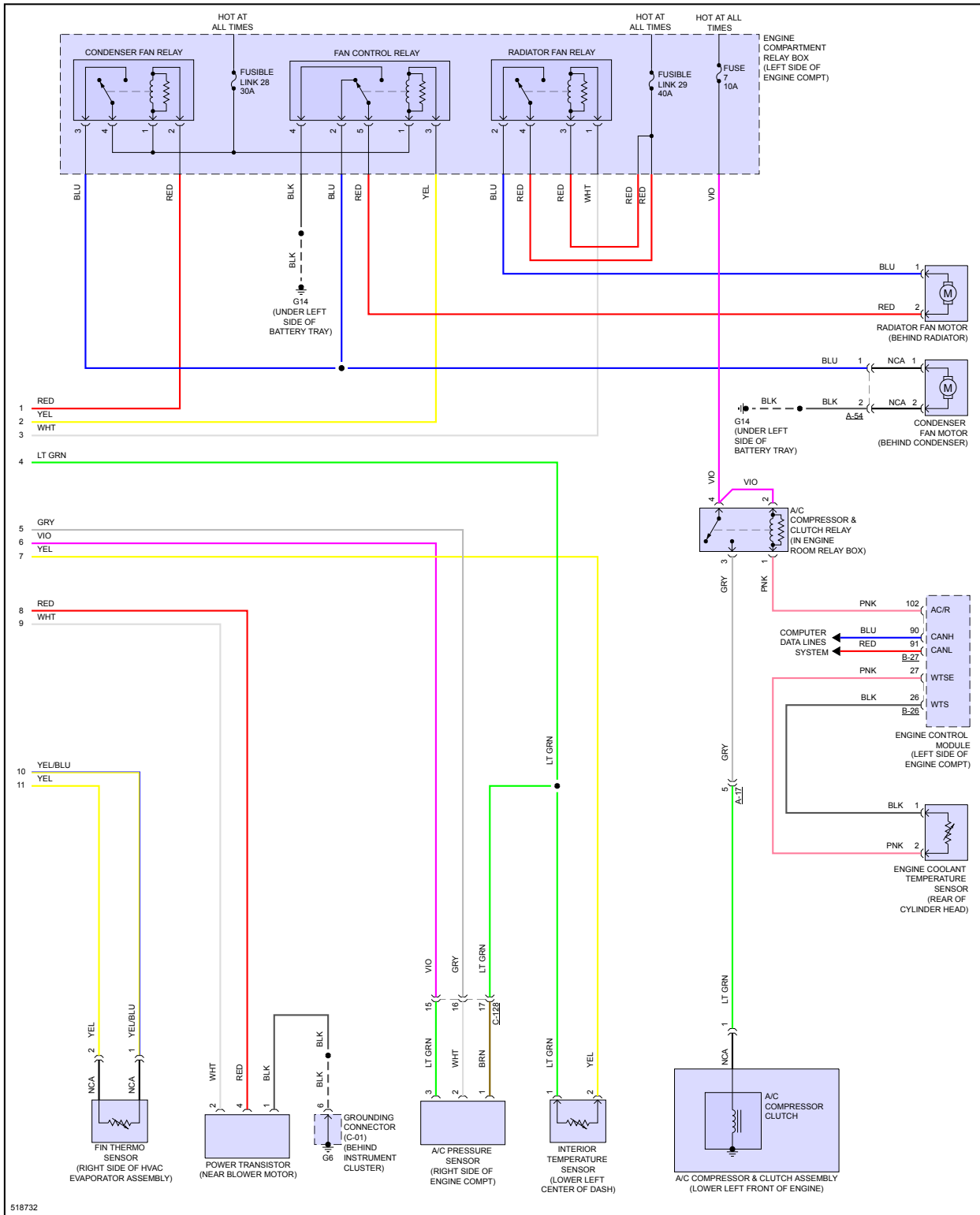

Fig 2: Automatic A/C Circuit (2 of 2)



ANTI-LOCK BRAKES

Fig 1: Anti-lock Brakes Circuit (1 of 2)

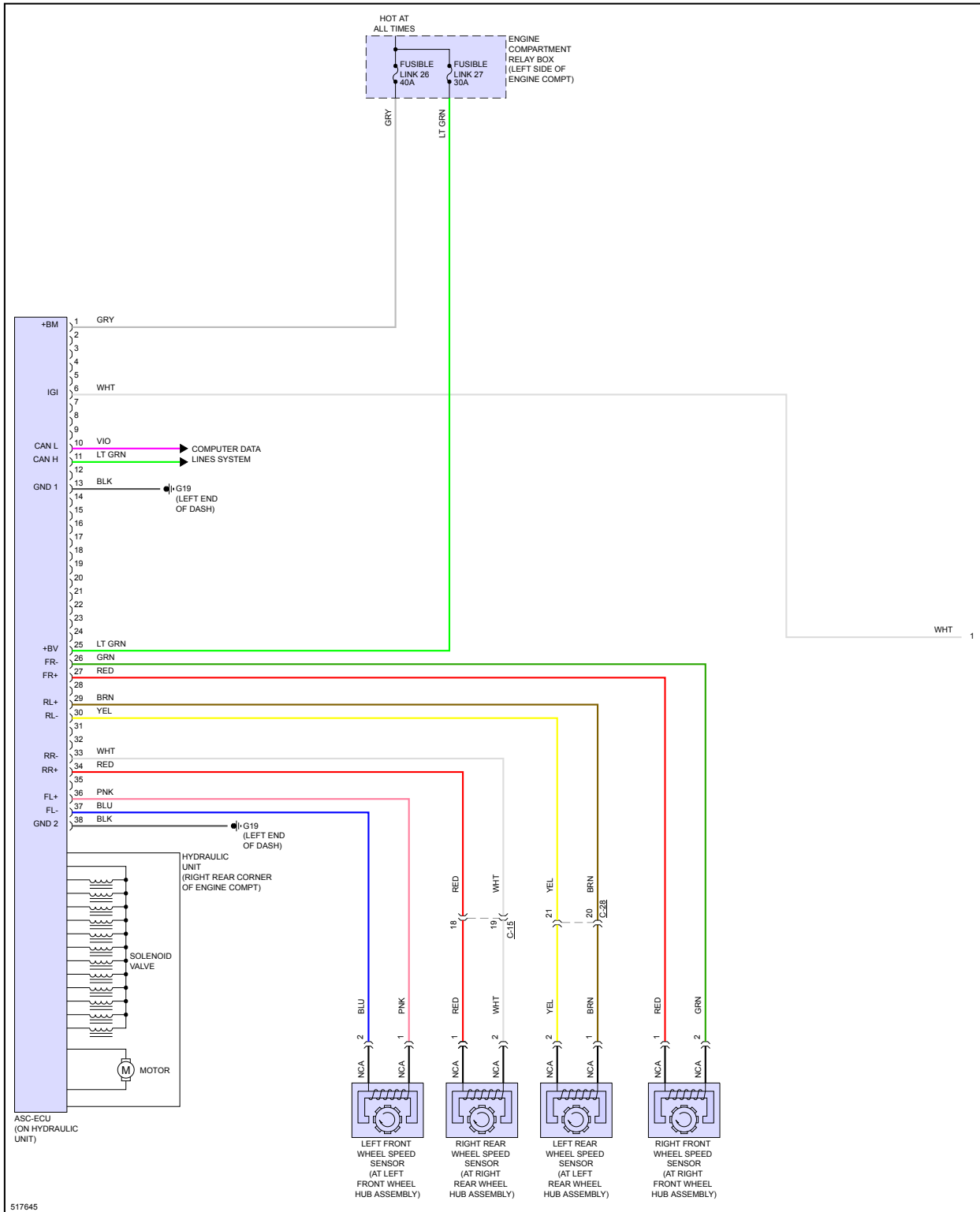
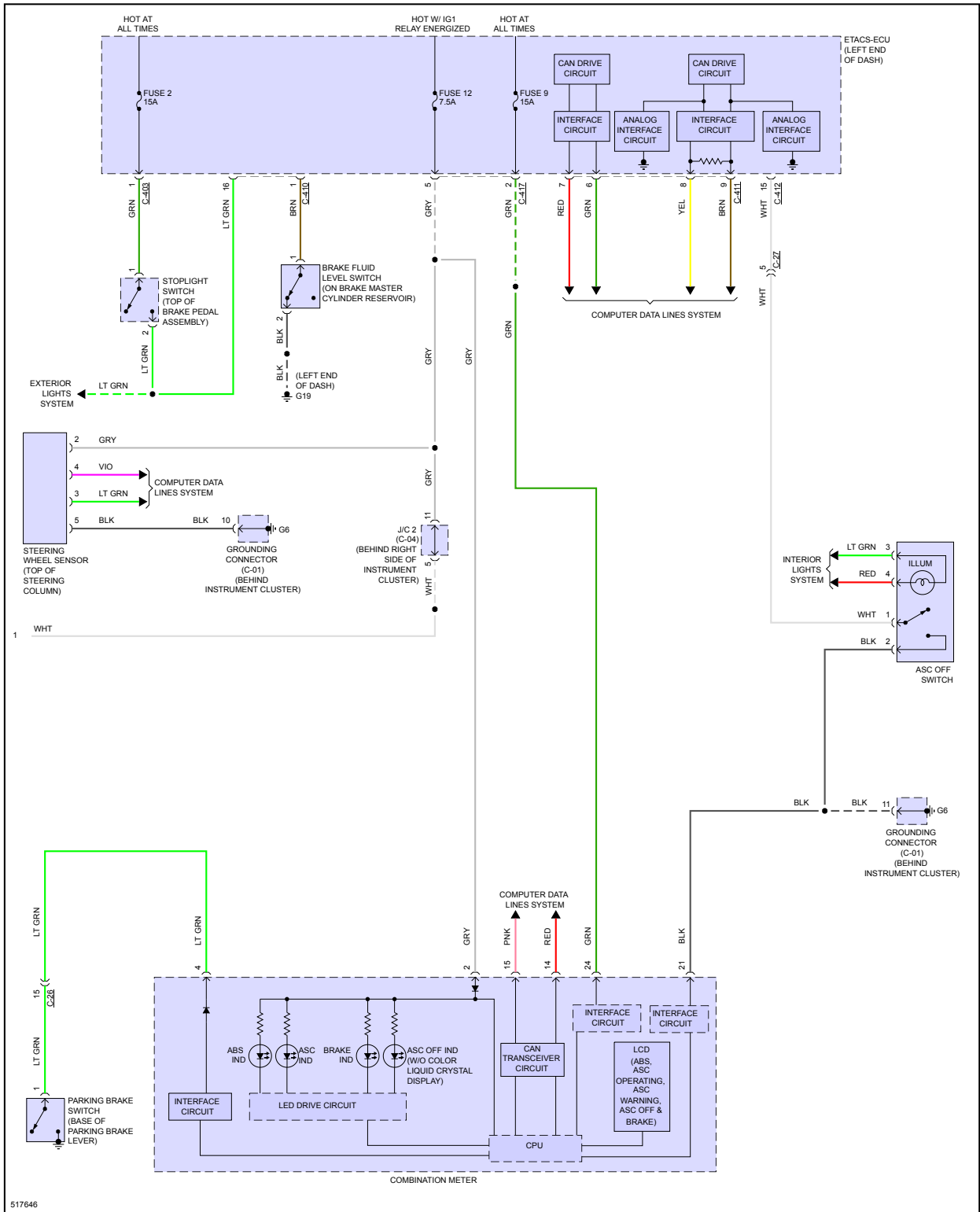

Fig 2: Anti-lock Brakes Circuit (2 of 2)



ANTI-THEFT

Fig 1: Forced Entry Circuit

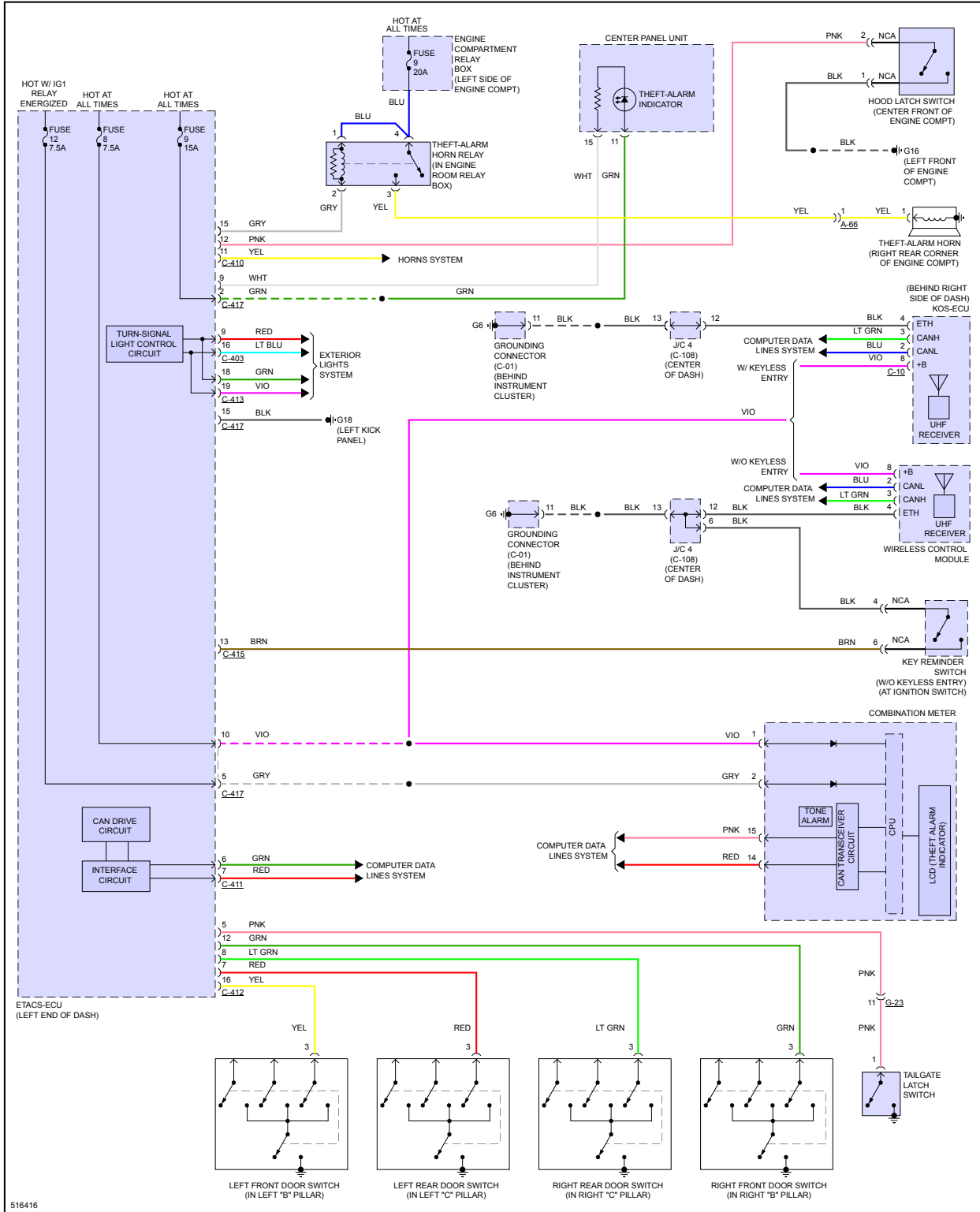
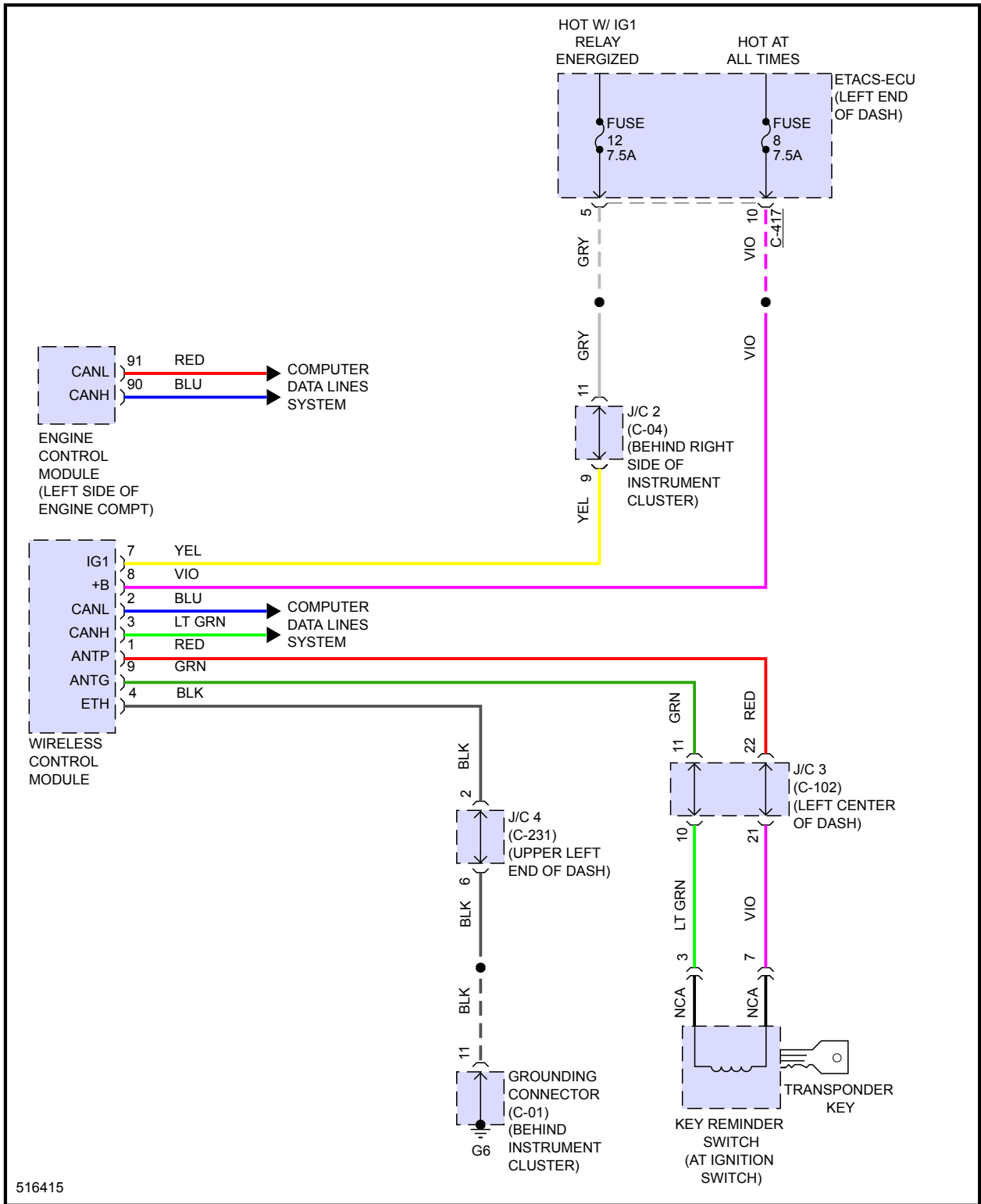
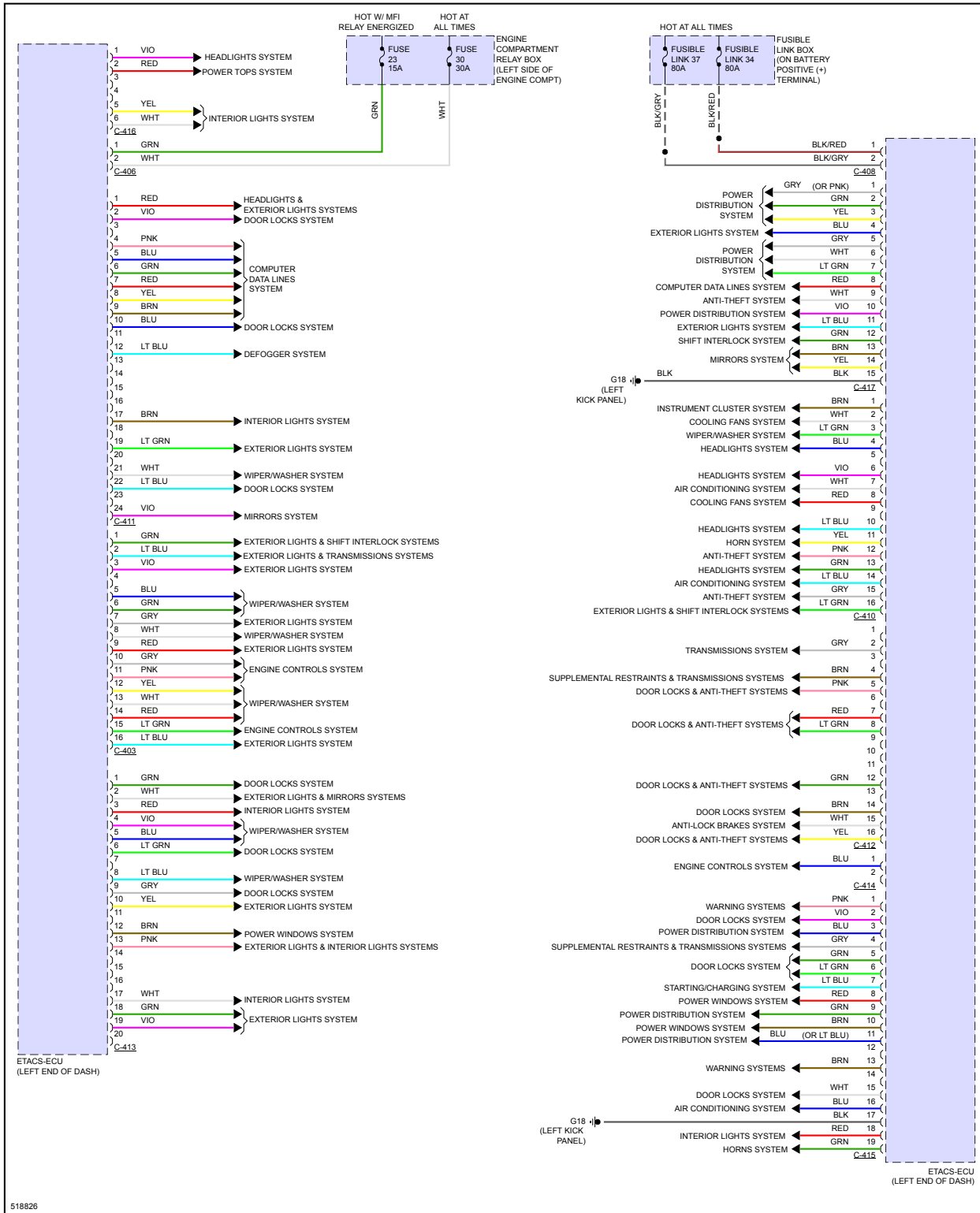

Fig 2: Immobilizer Circuit



BODY CONTROL MODULES

Fig 1: Body Control Modules Circuit



COMPUTER DATA LINES

Fig 1: Computer Data Lines Circuit

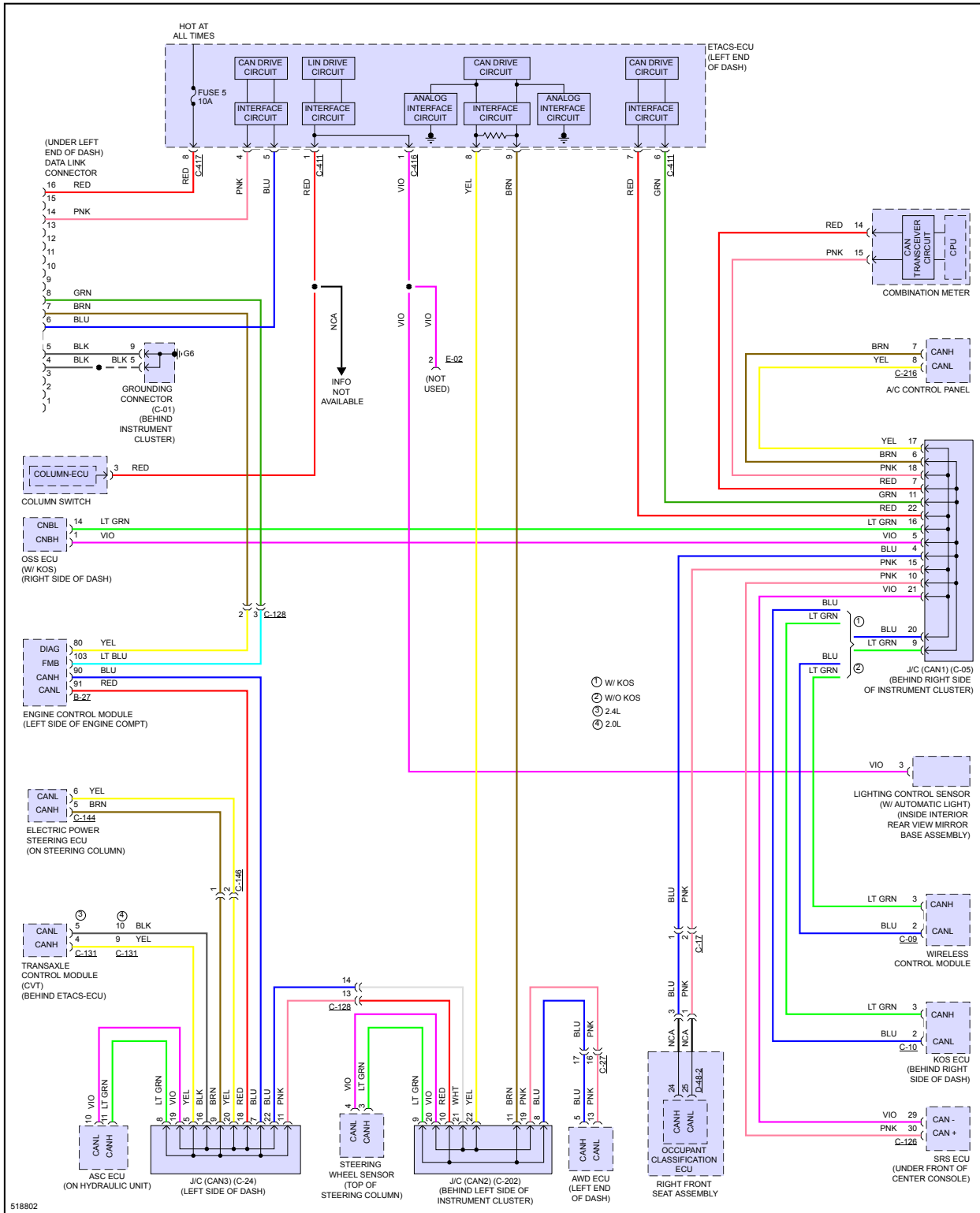

COOLING FAN

Fig 1: Cooling Fan Circuit

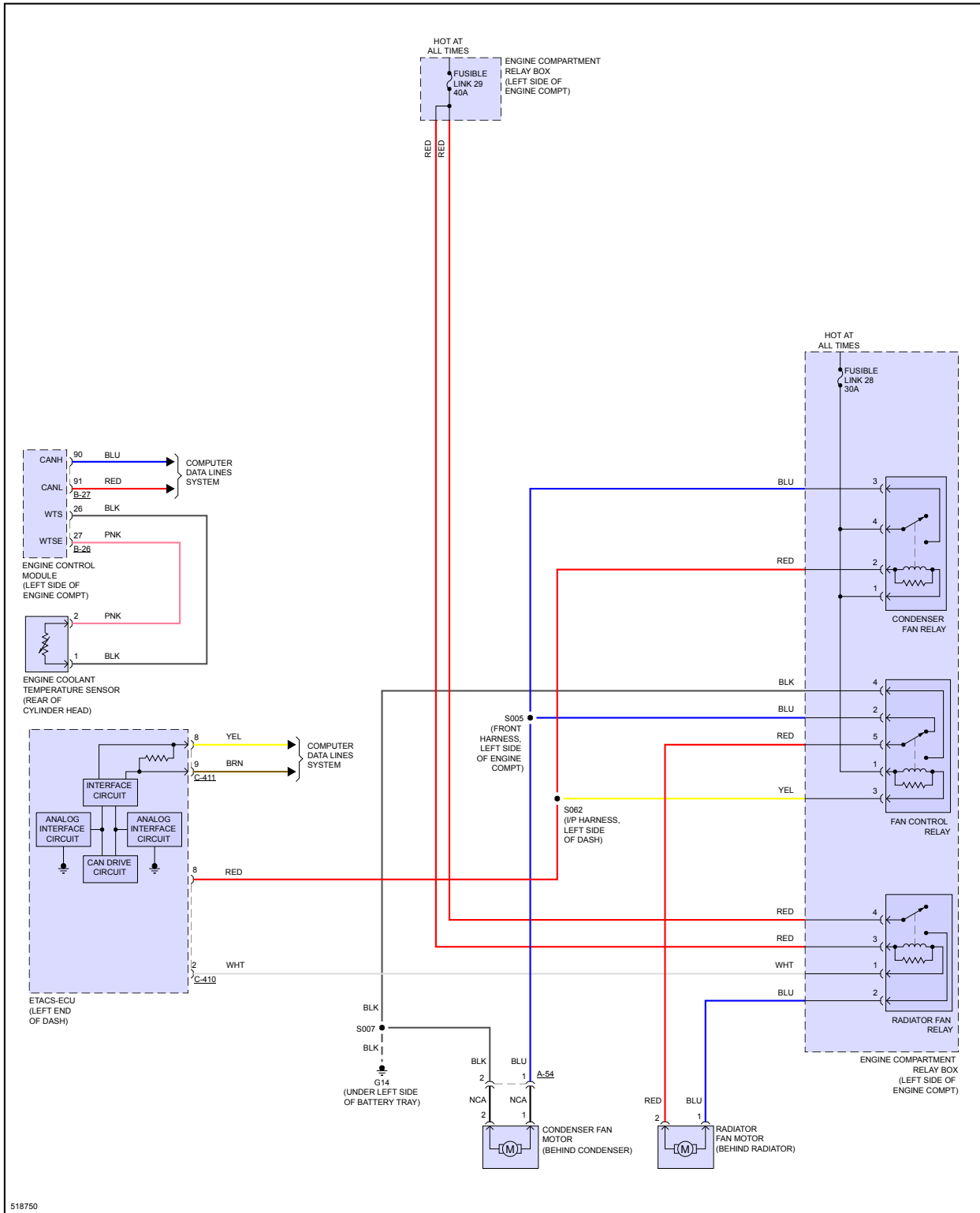

CRUISE CONTROL

Fig 1: Cruise Control Circuit (1 of 2)

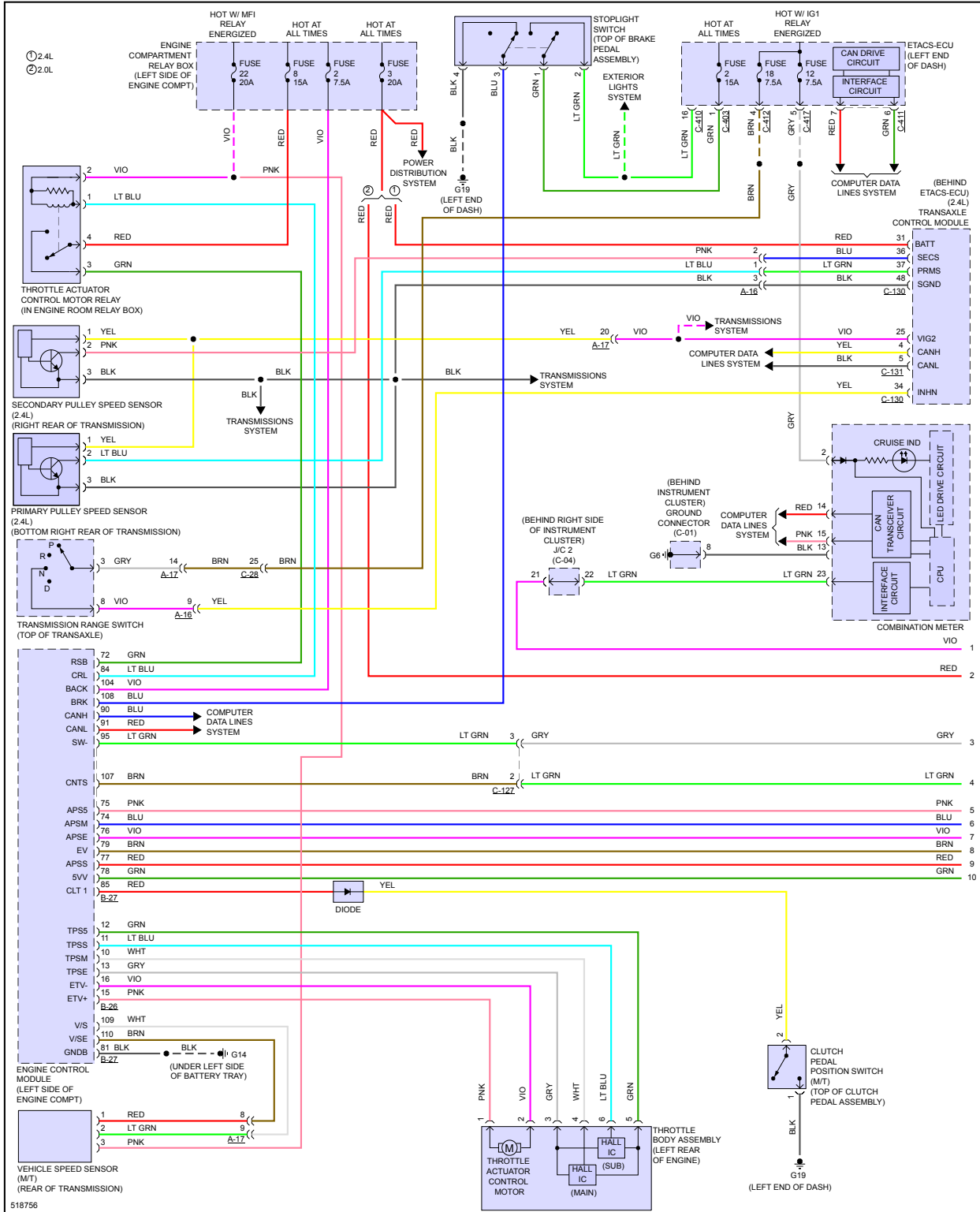
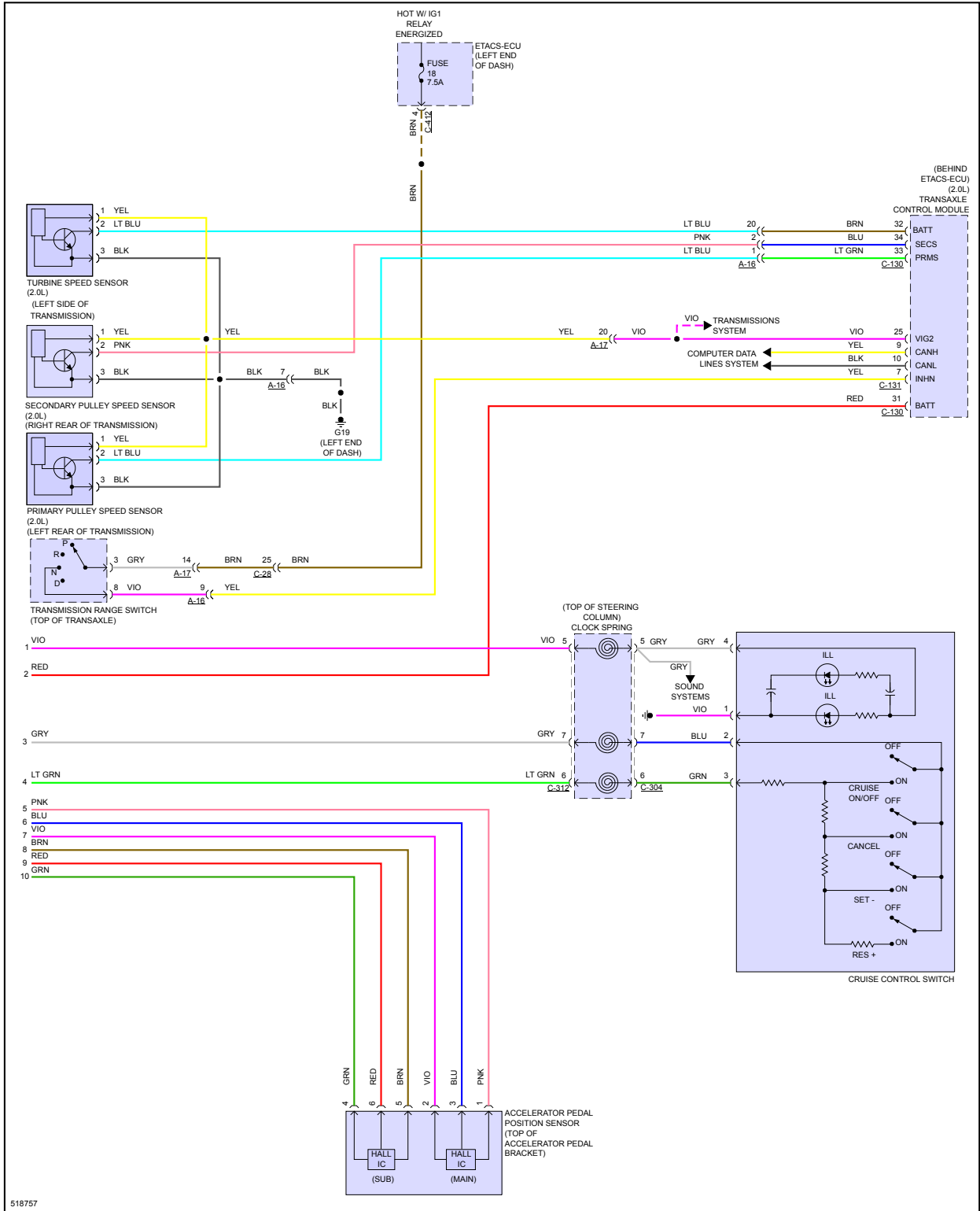
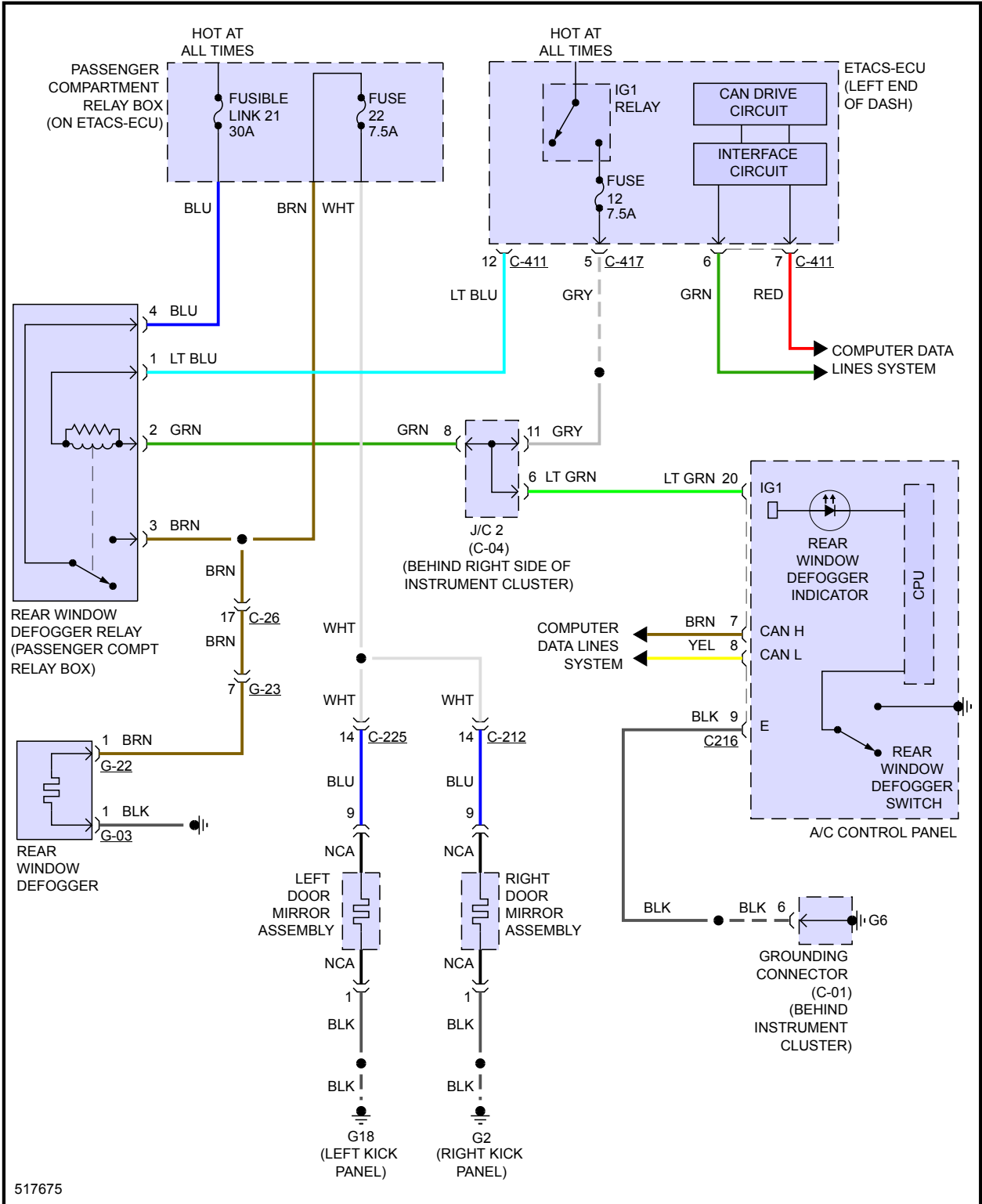

Fig 2: Cruise Control Circuit (2 of 2)



DEFOGGERS

Fig 1: Defoggers Circuit



ELECTRONIC POWER STEERING

Fig 1: Electronic Power Steering Circuit

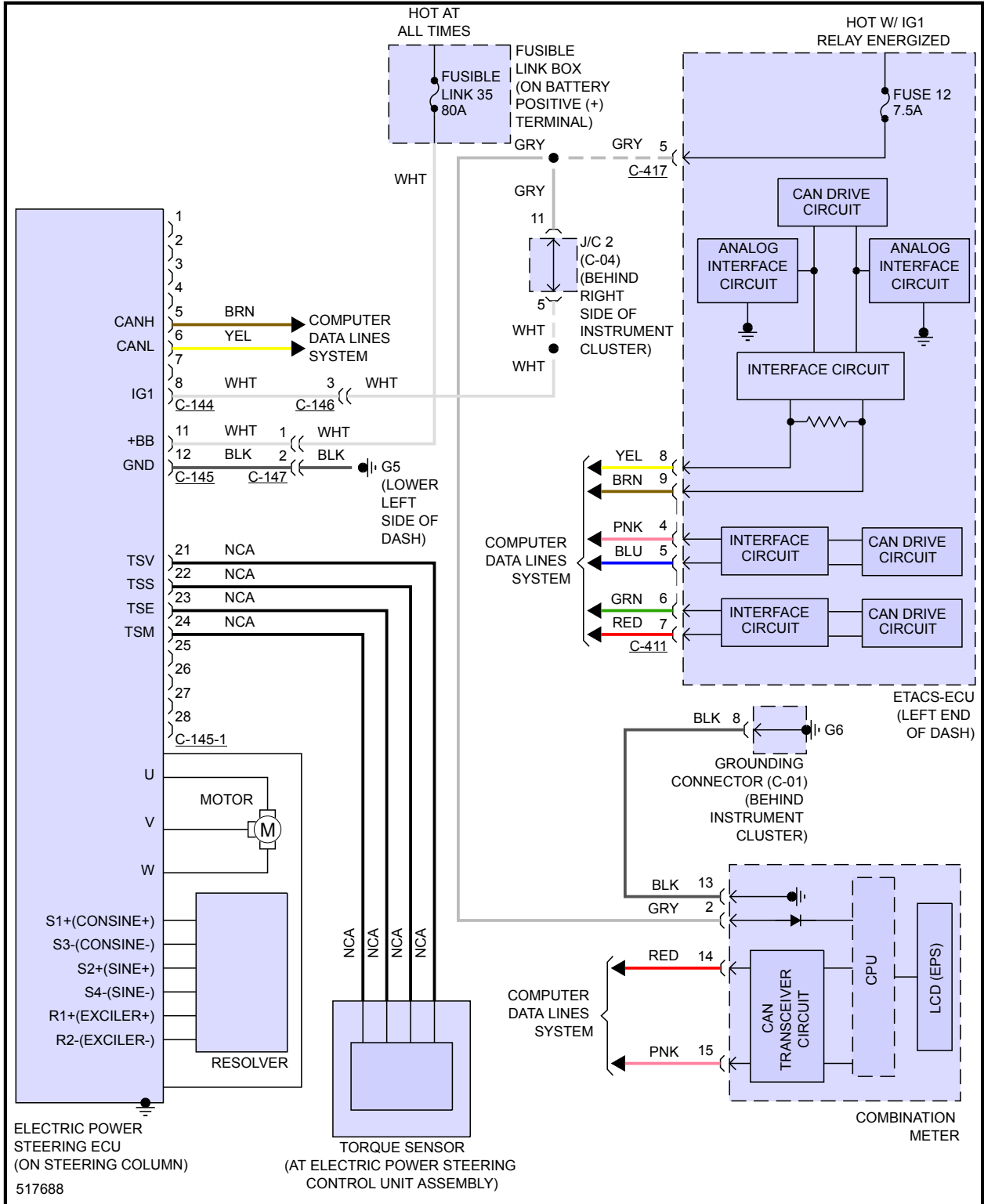

ENGINE PERFORMANCE > 2.0L

Fig 1: 2.0L, Engine Performance Circuit (1 of 4)

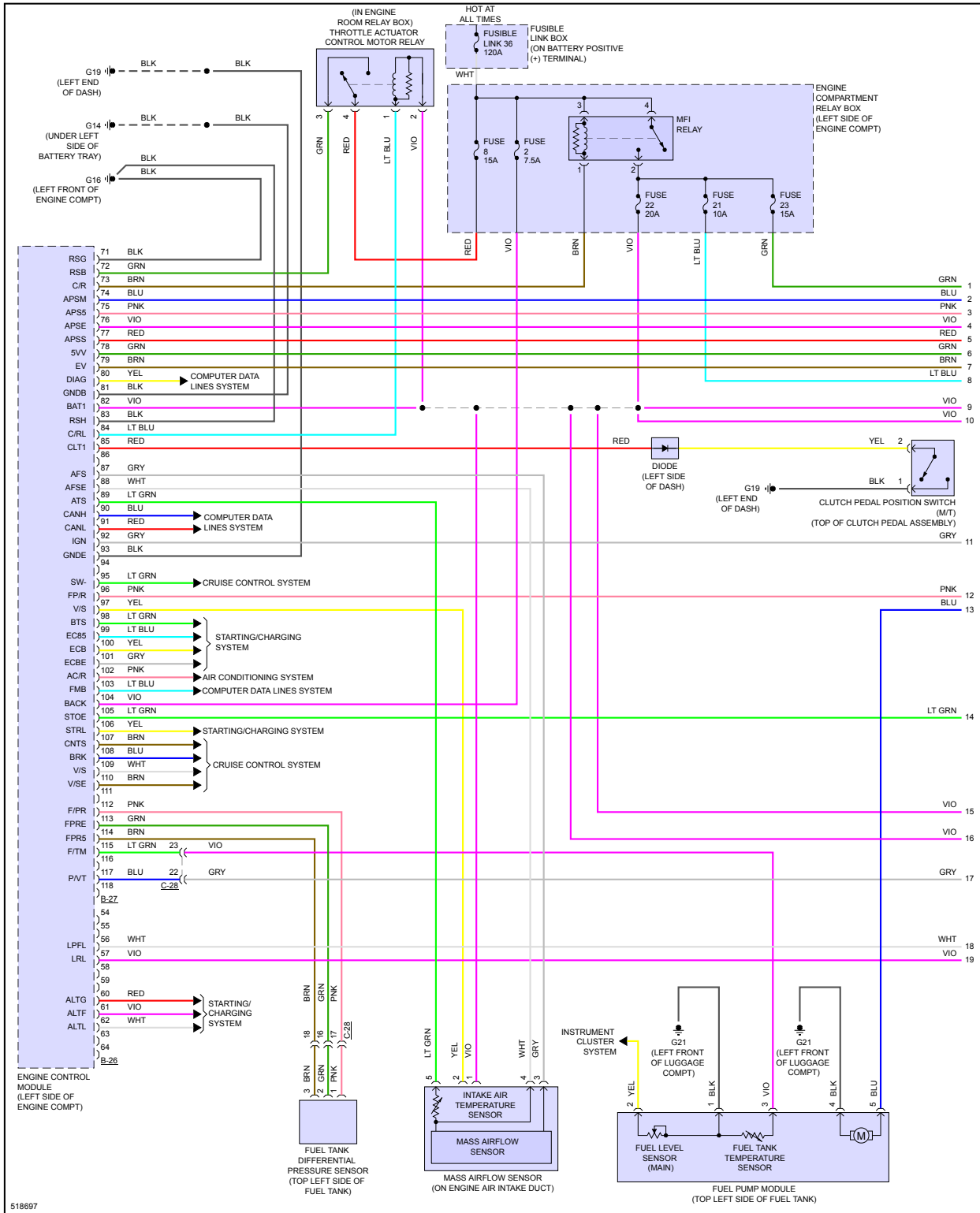

Fig 2: 2.0L, Engine Performance Circuit (2 of 4)

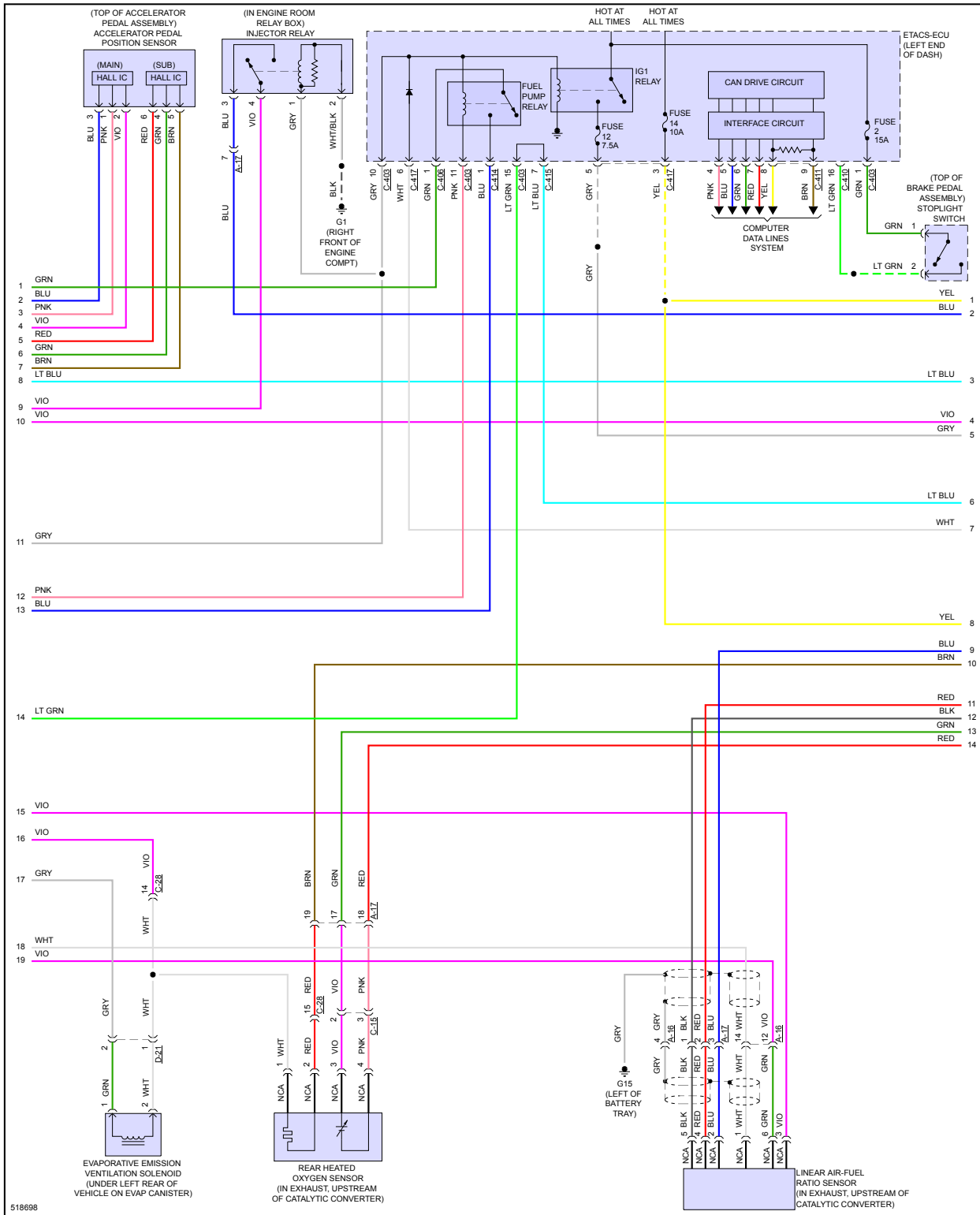

Fig 3: 2.0L, Engine Performance Circuit (3 of 4)

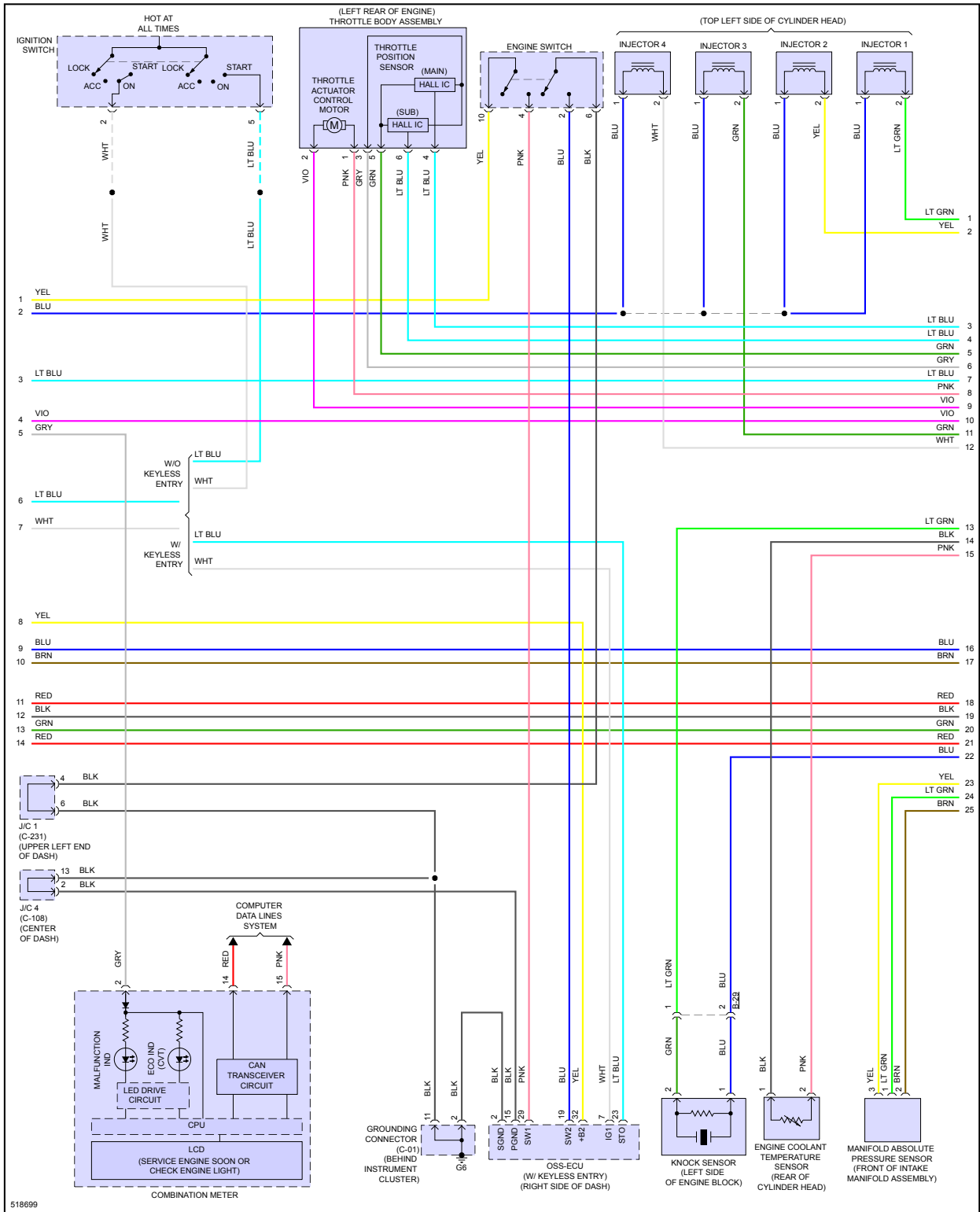
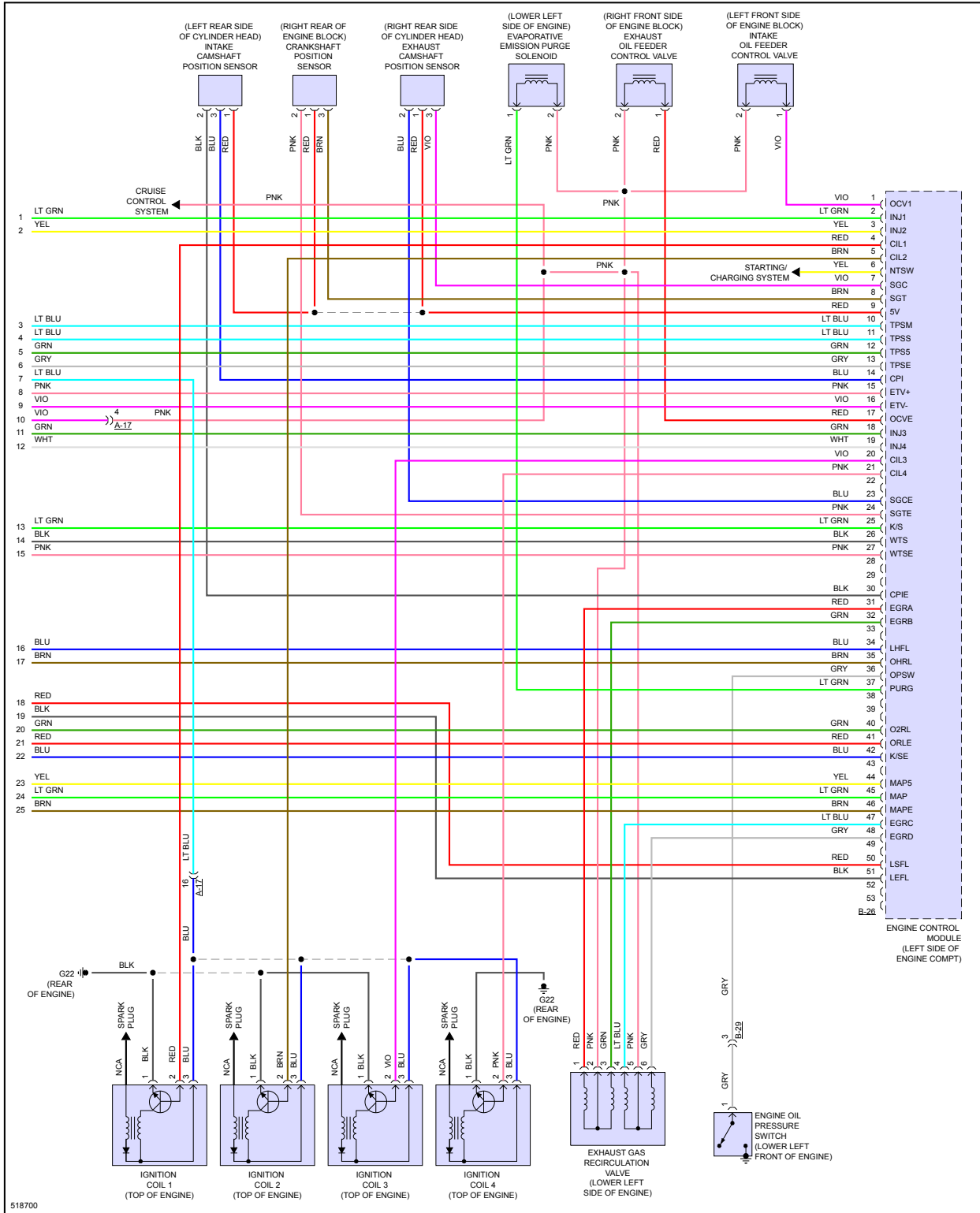

Fig 4: 2.0L, Engine Performance Circuit (4 of 4)



ENGINE PERFORMANCE > 2.4L

Fig 1: 2.4L, Engine Performance Circuit (1 of 4)

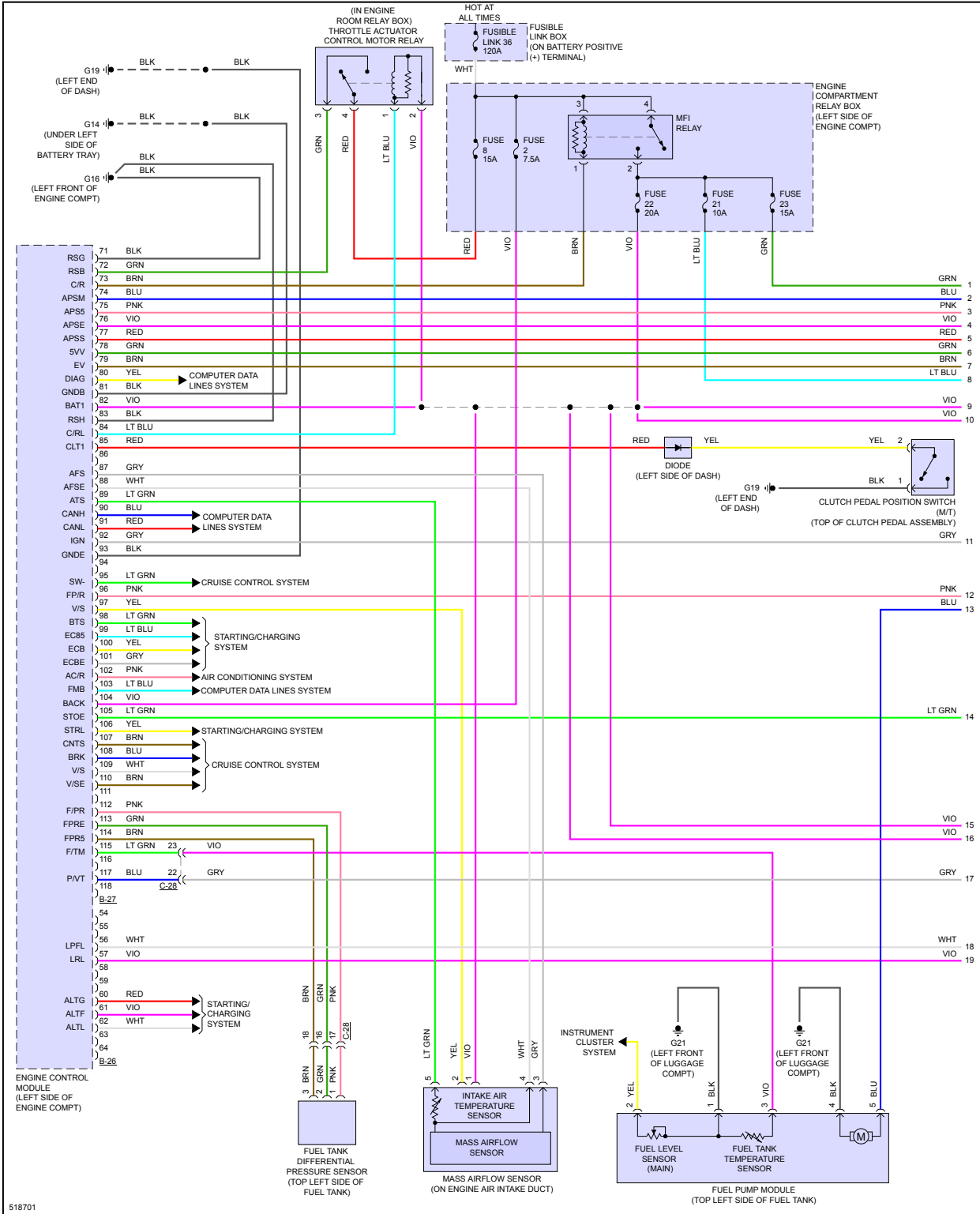

Fig 2: 2.4L, Engine Performance Circuit (2 of 4)

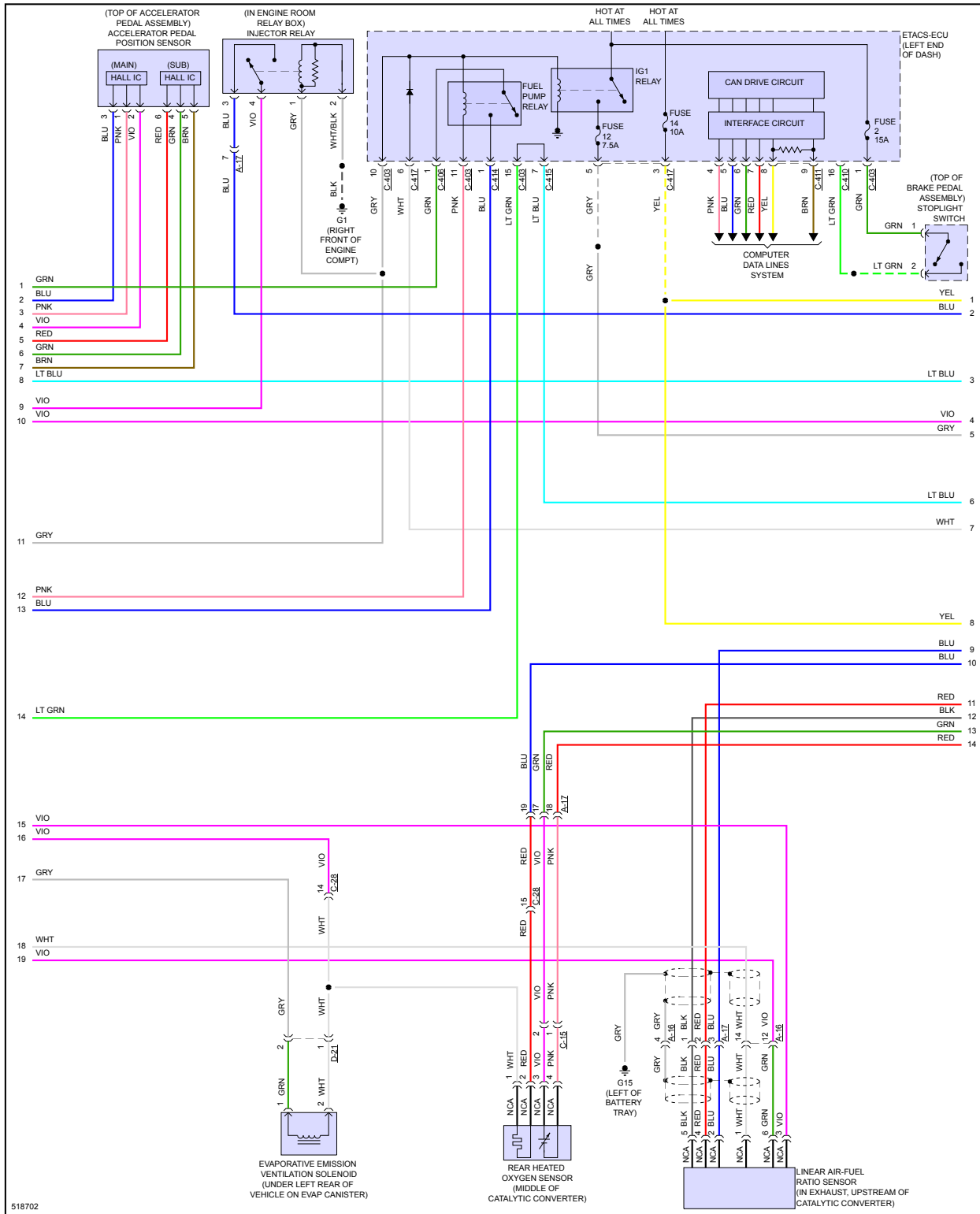

Fig 3: 2.4L, Engine Performance Circuit (3 of 4)

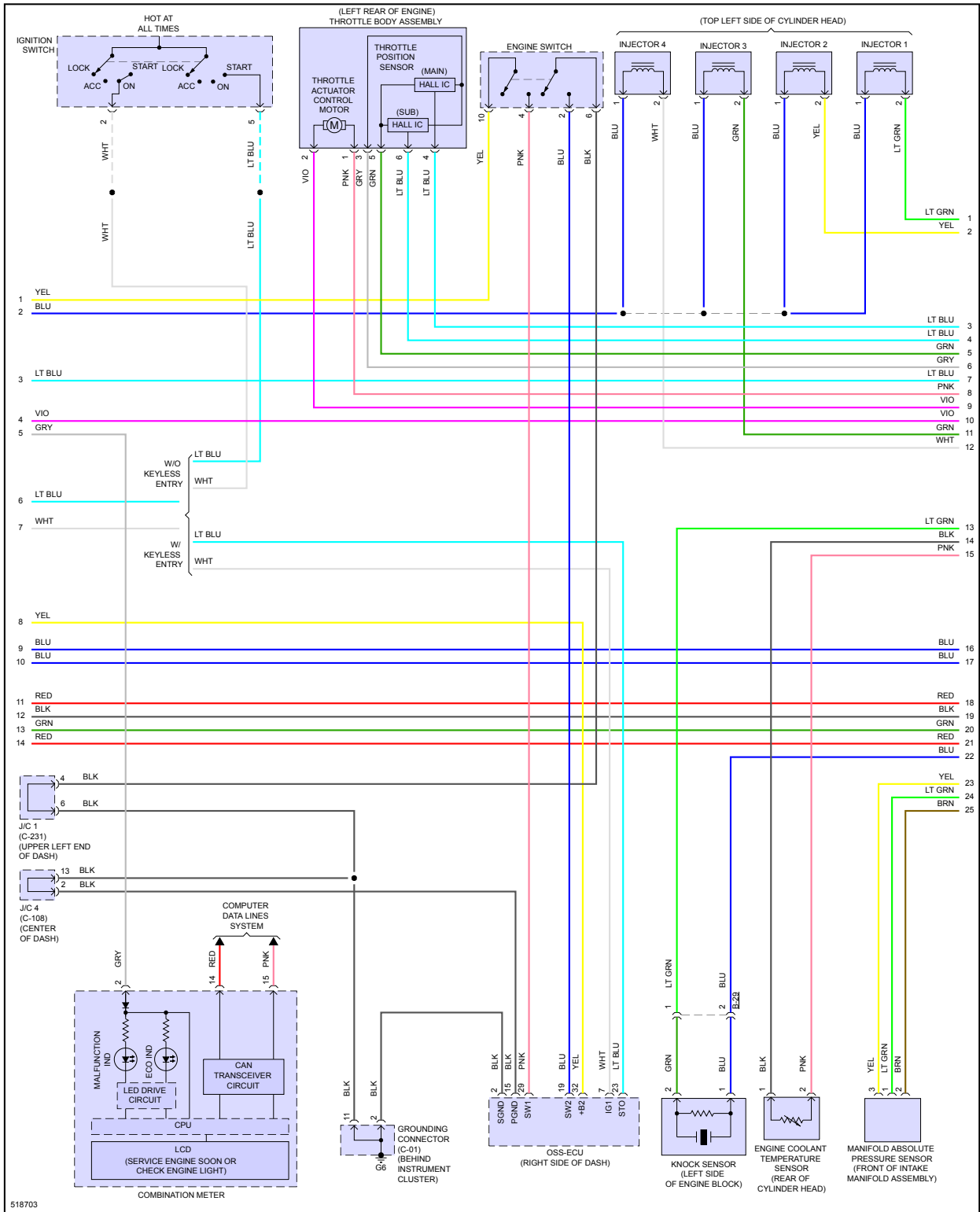
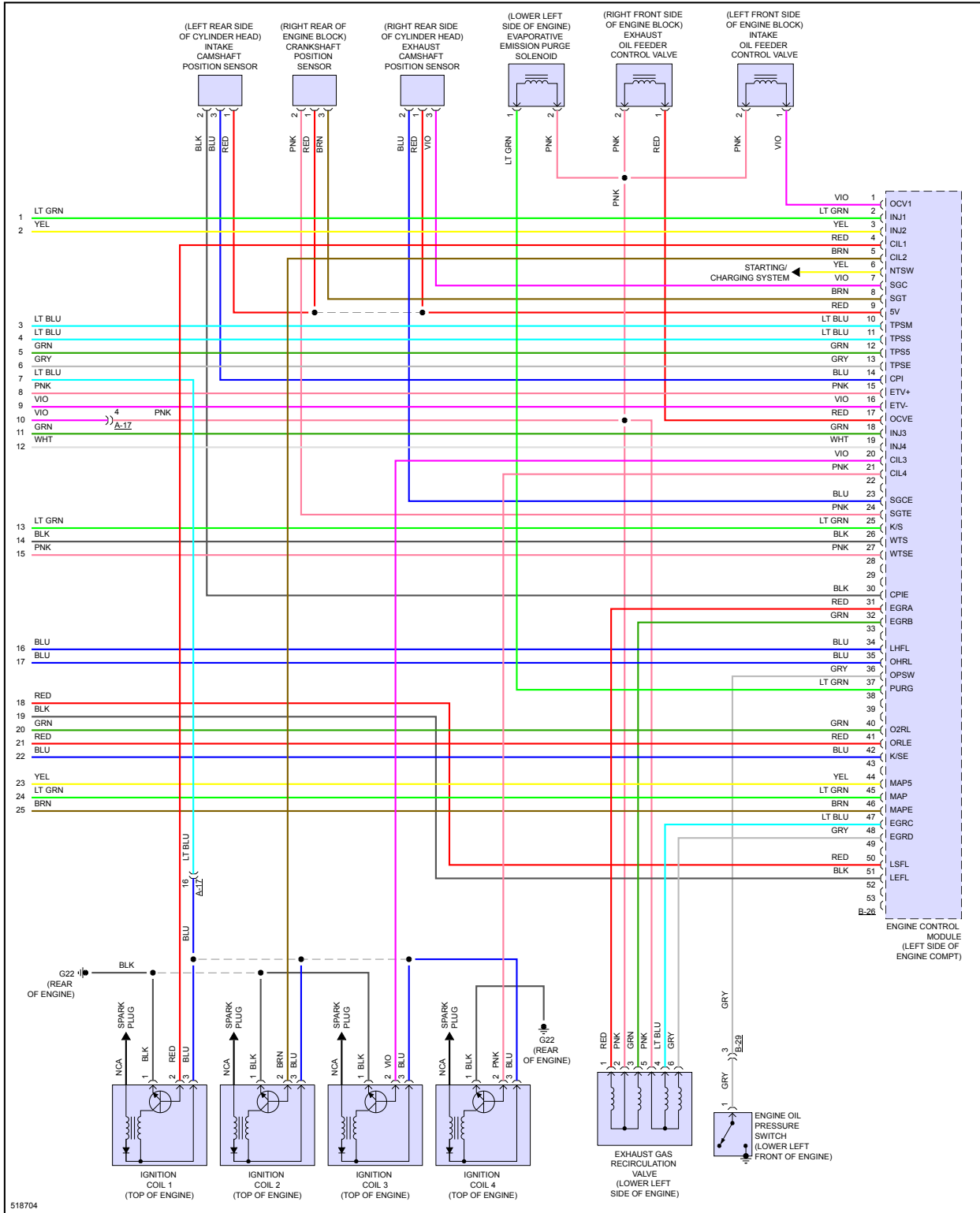

Fig 4: 2.4L, Engine Performance Circuit (4 of 4)



EXTERIOR LIGHTS

Fig 1: Backup Lamps Circuit

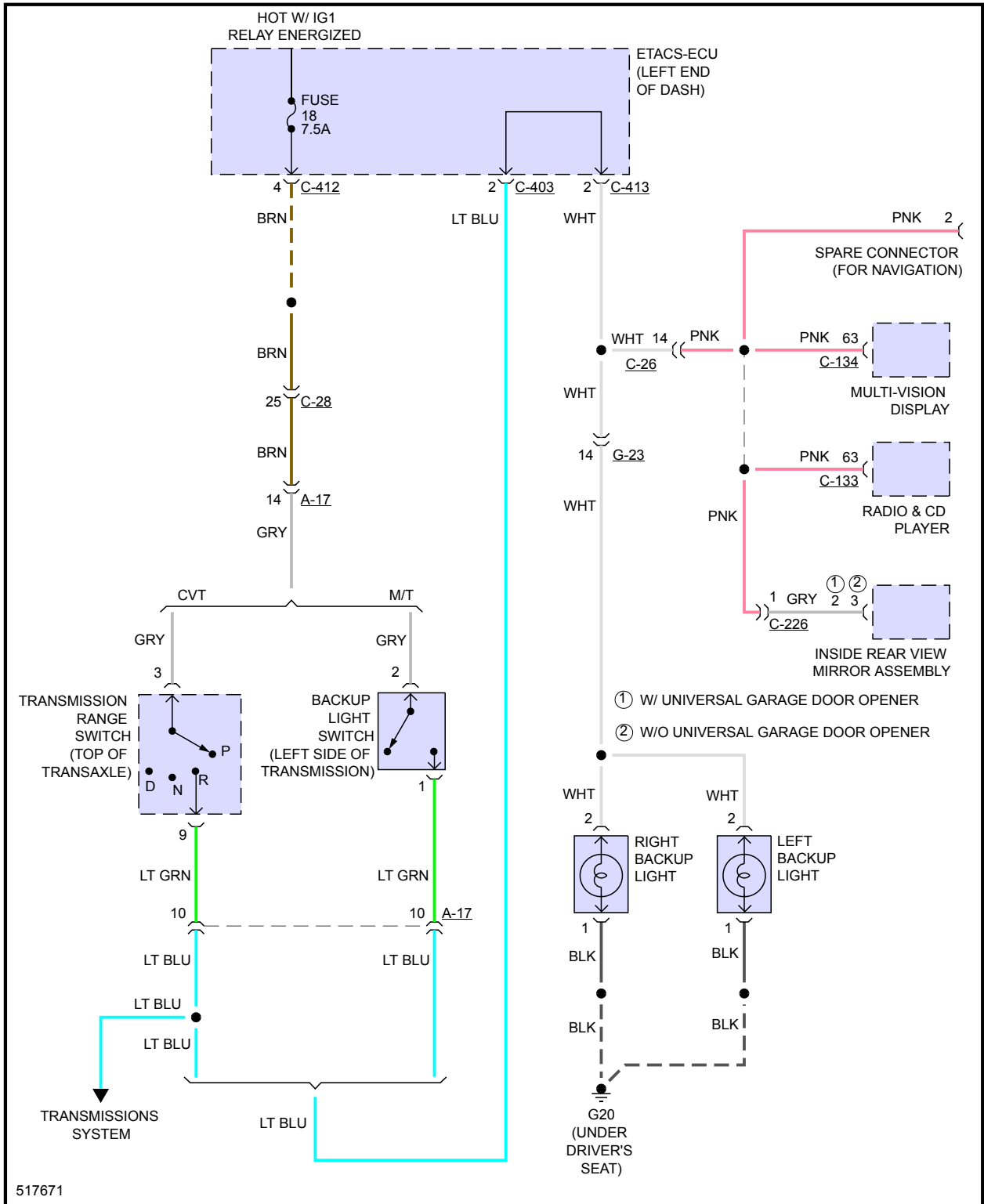

Fig 2: Exterior Lamps Circuit (1 of 2)

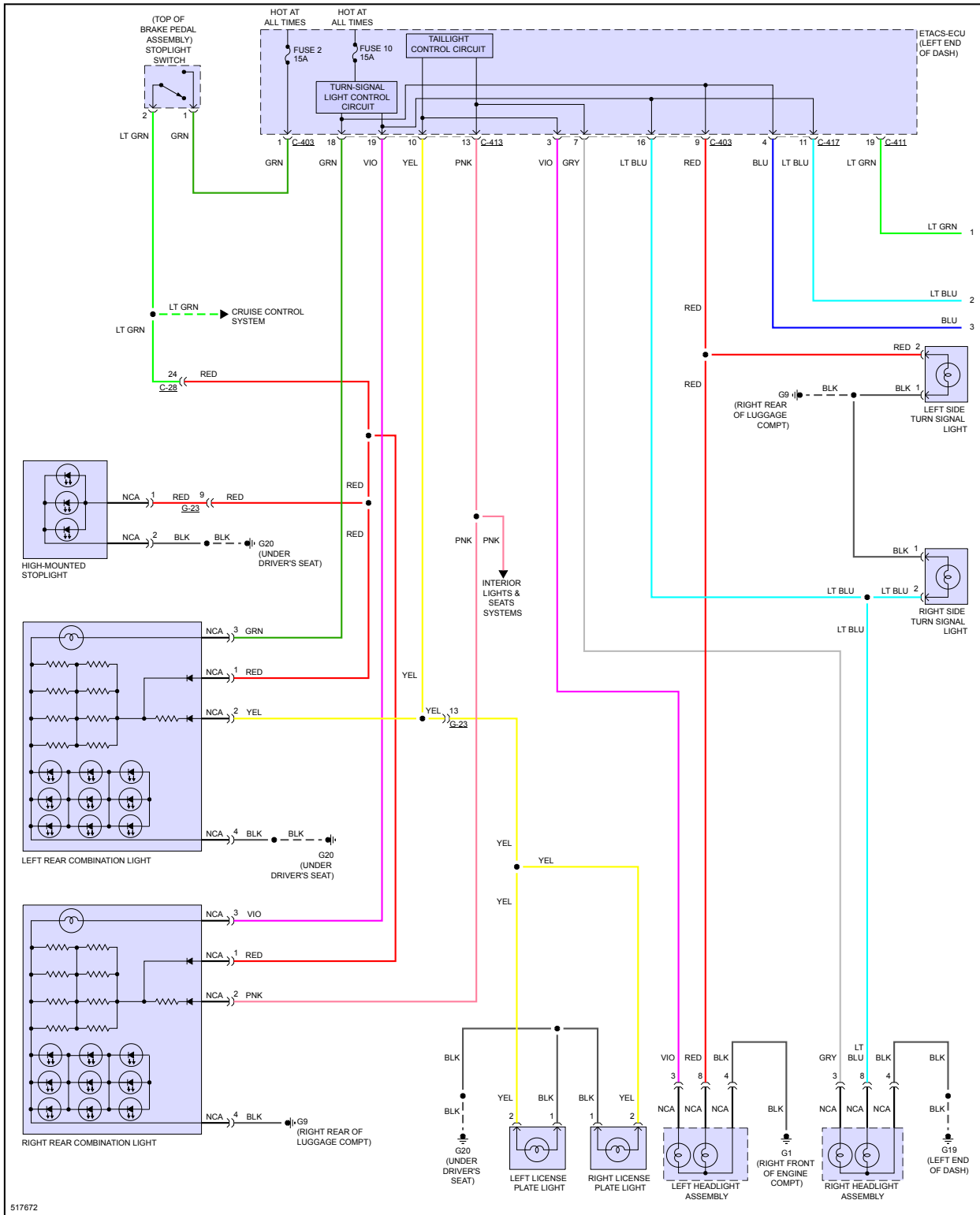
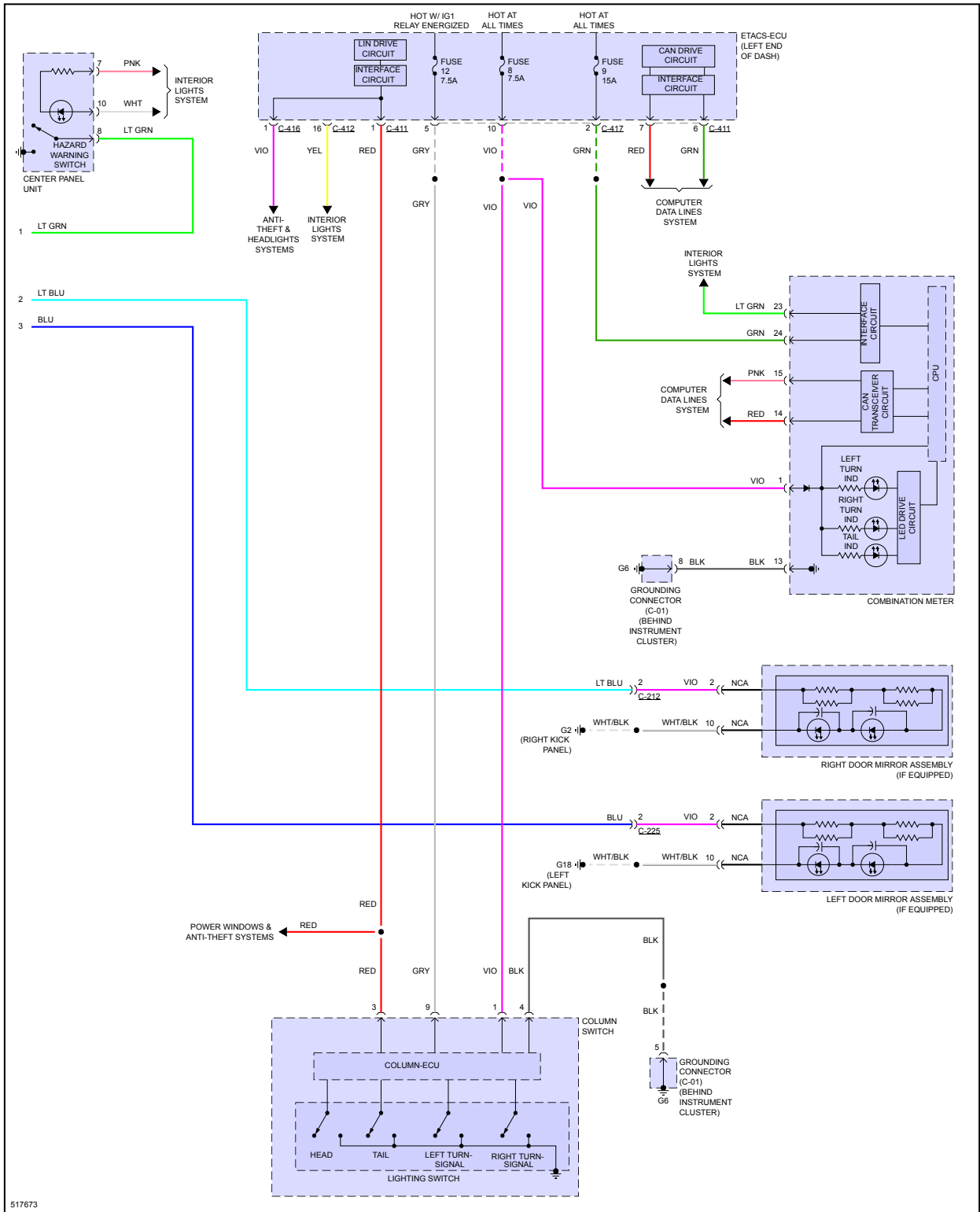
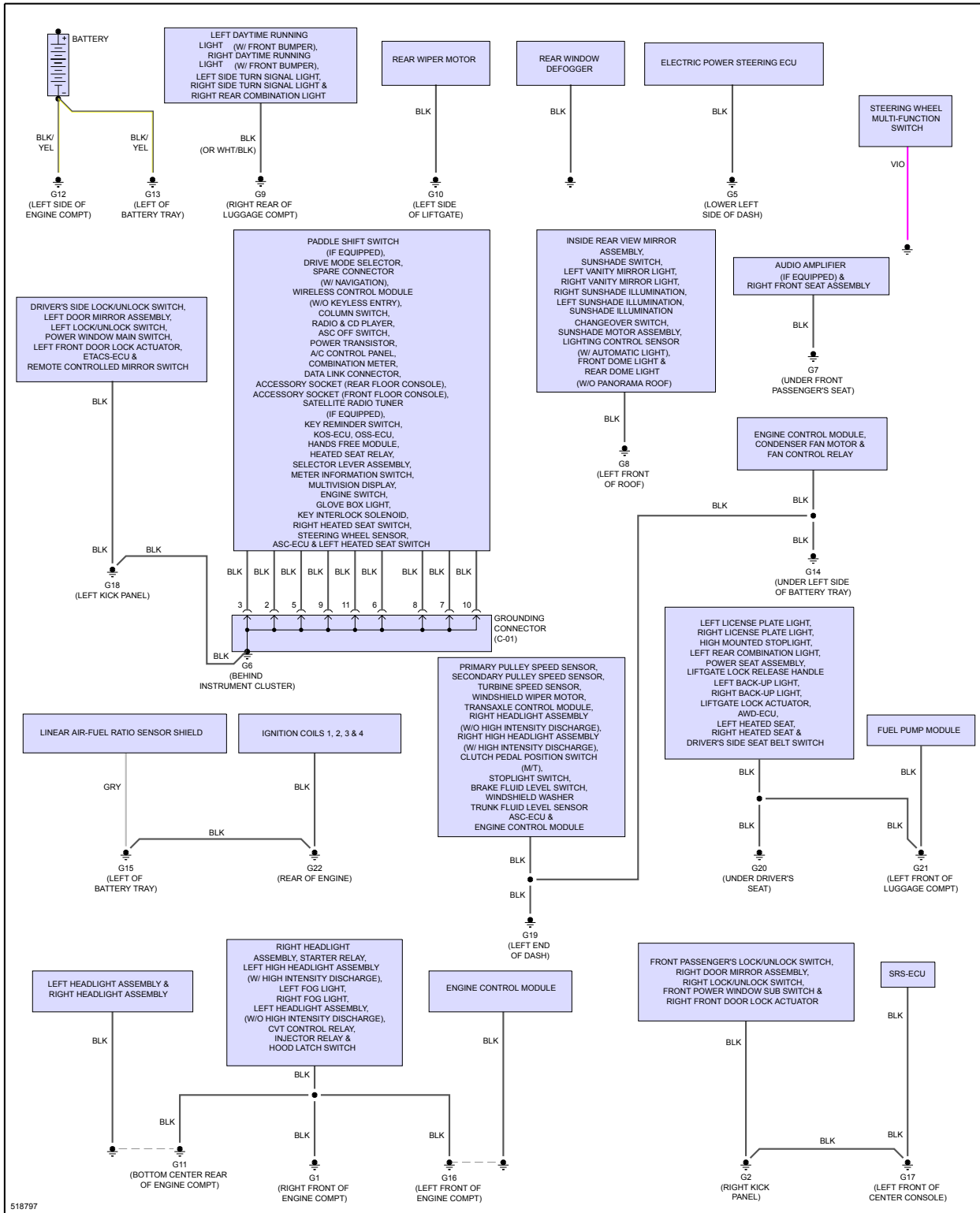

Fig 3: Exterior Lamps Circuit (2 of 2)



GROUND DISTRIBUTION

Fig 1: Ground Distribution Circuit



HEADLIGHTS

Fig 1: Headlights Circuit, W/ High Intensity Discharge (1 of 2)

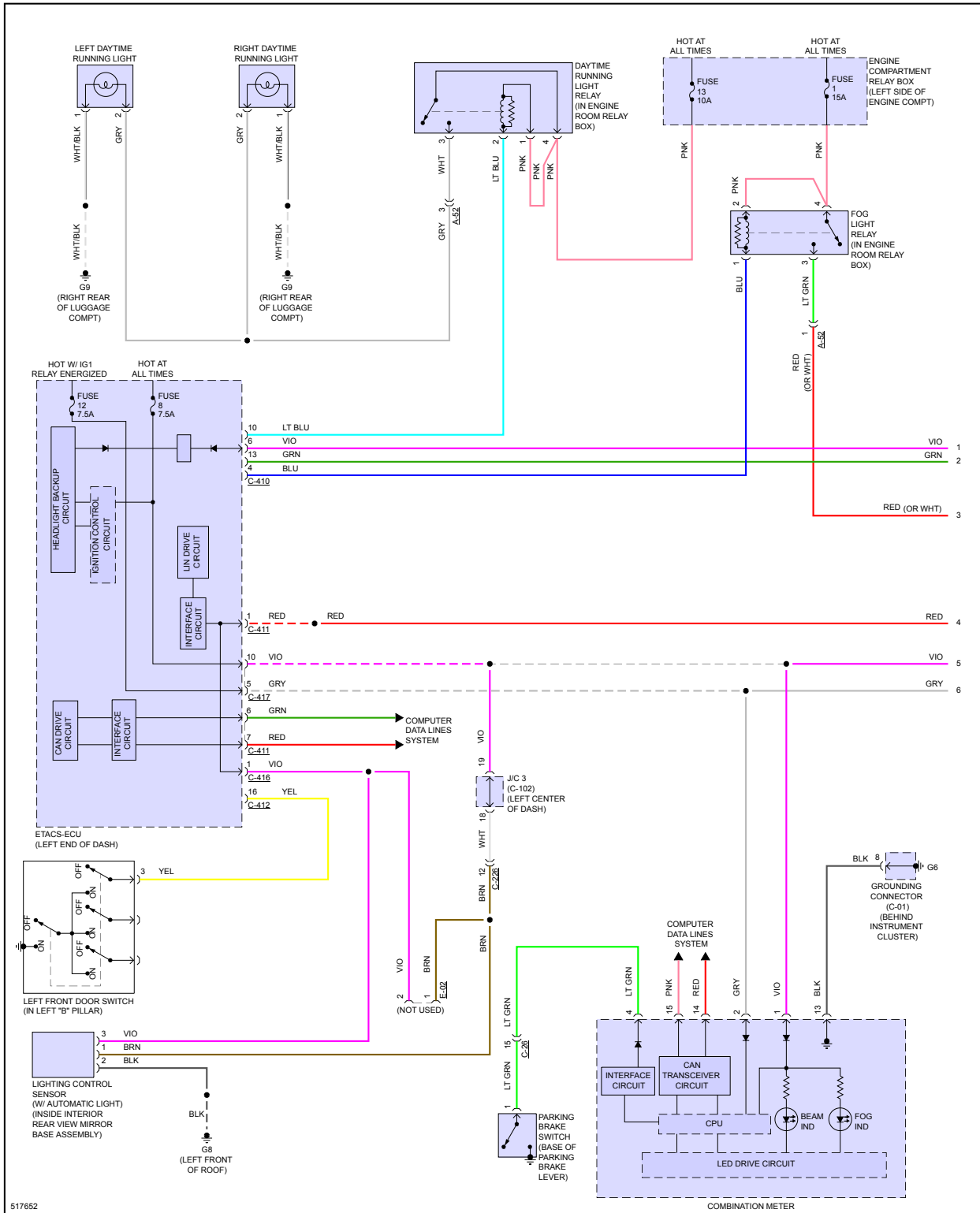

Fig 2: Headlights Circuit, W/ High Intensity Discharge (2 of 2)

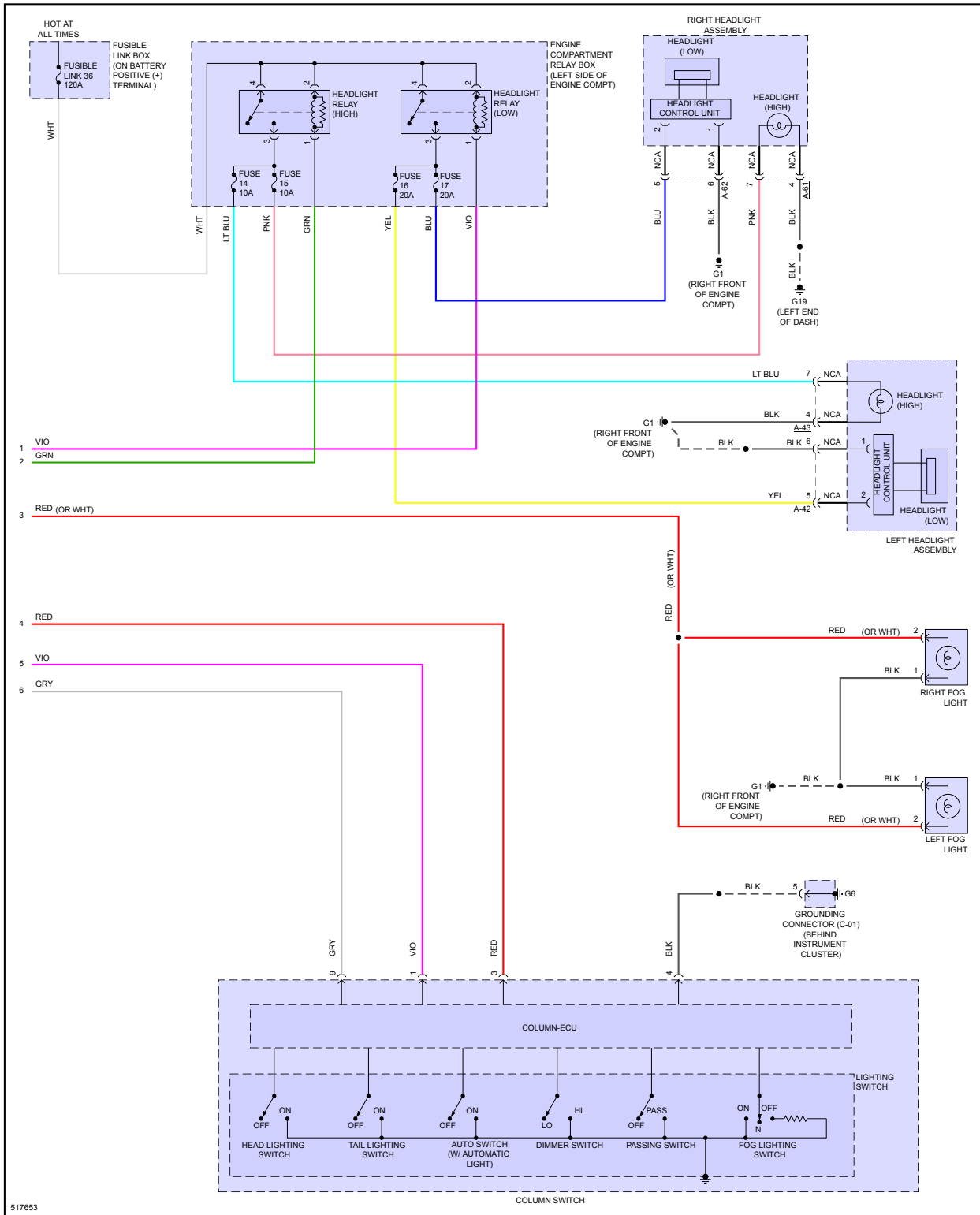

Fig 3: Headlights Circuit, W/O High Intensity Discharge (1 of 2)

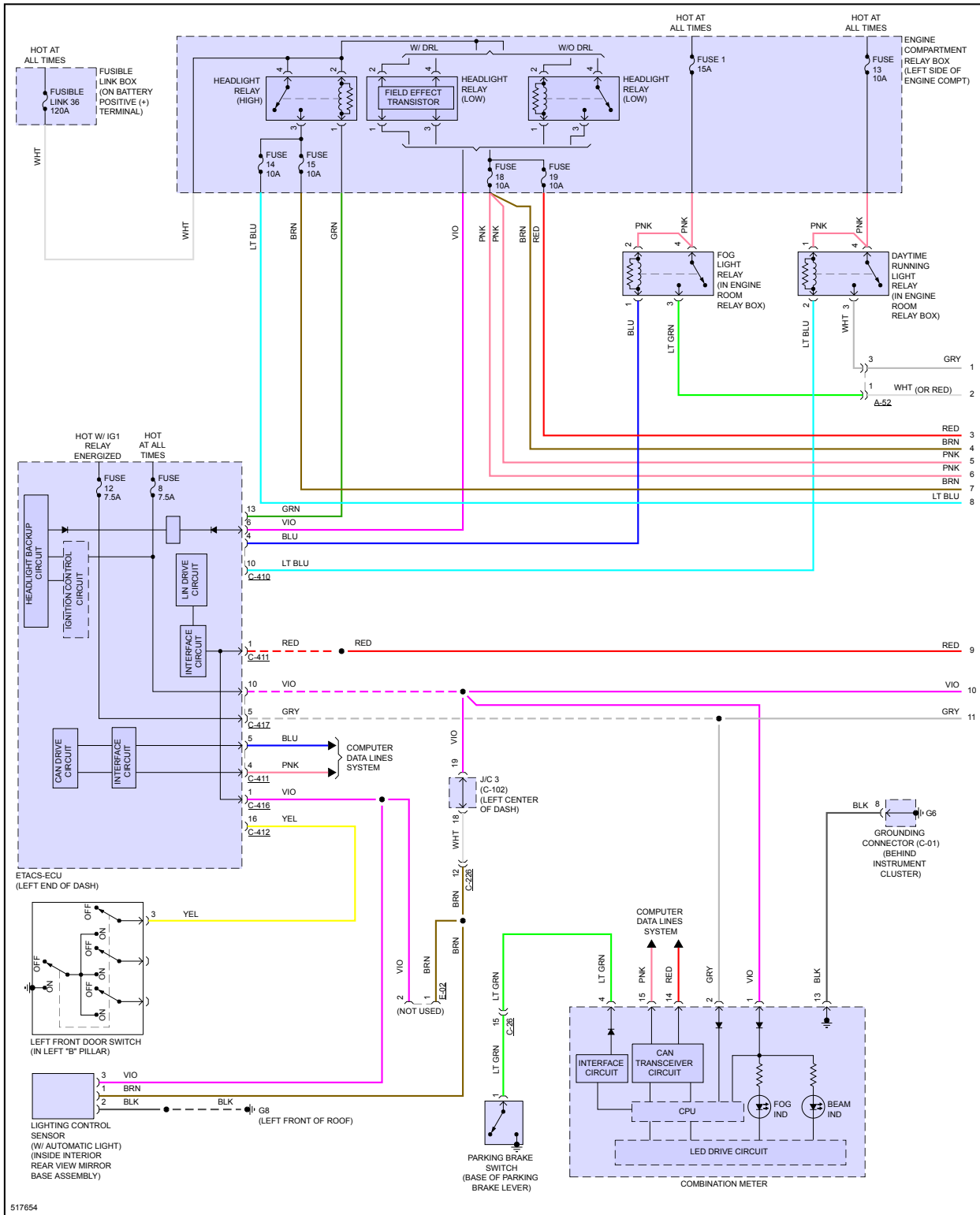
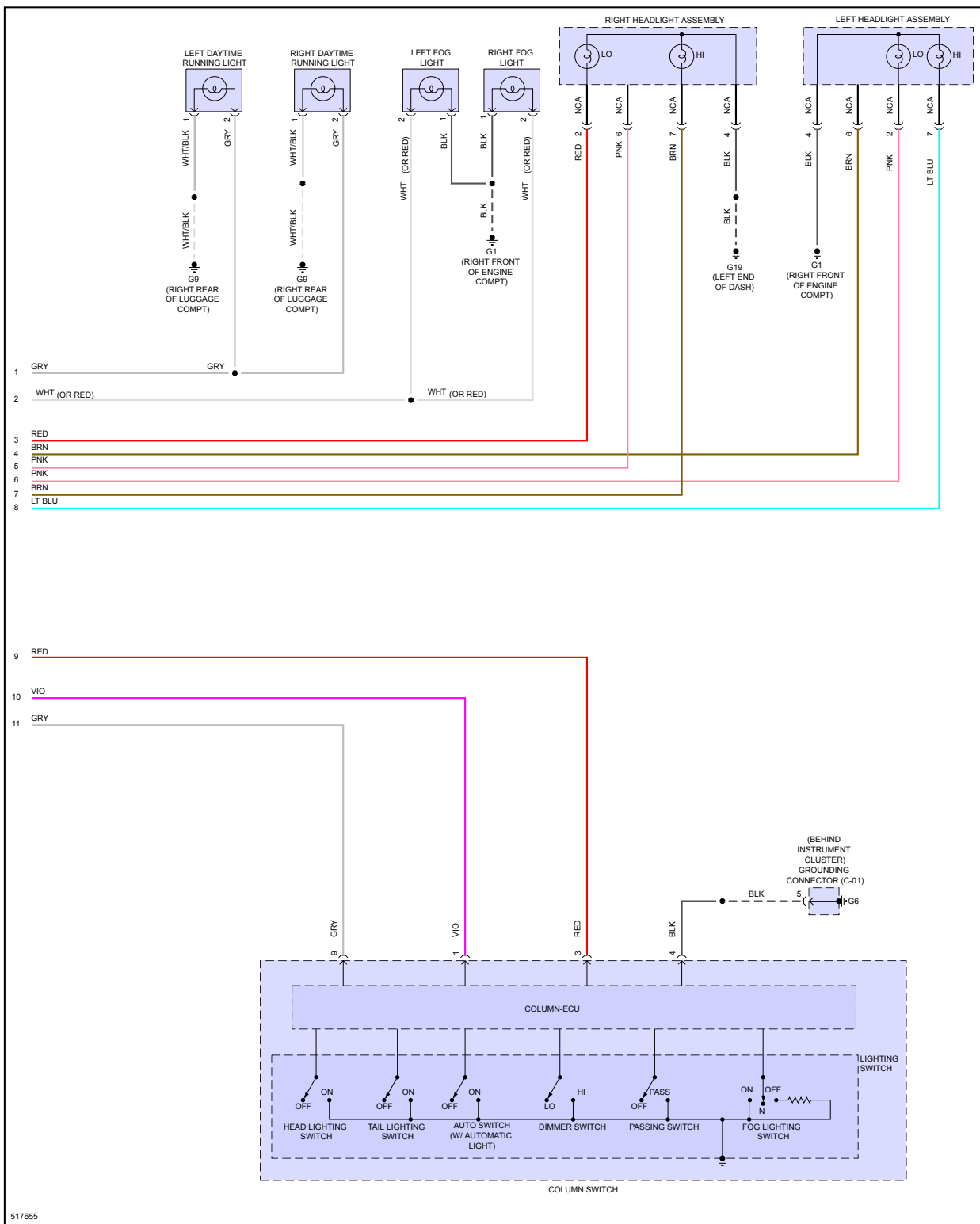
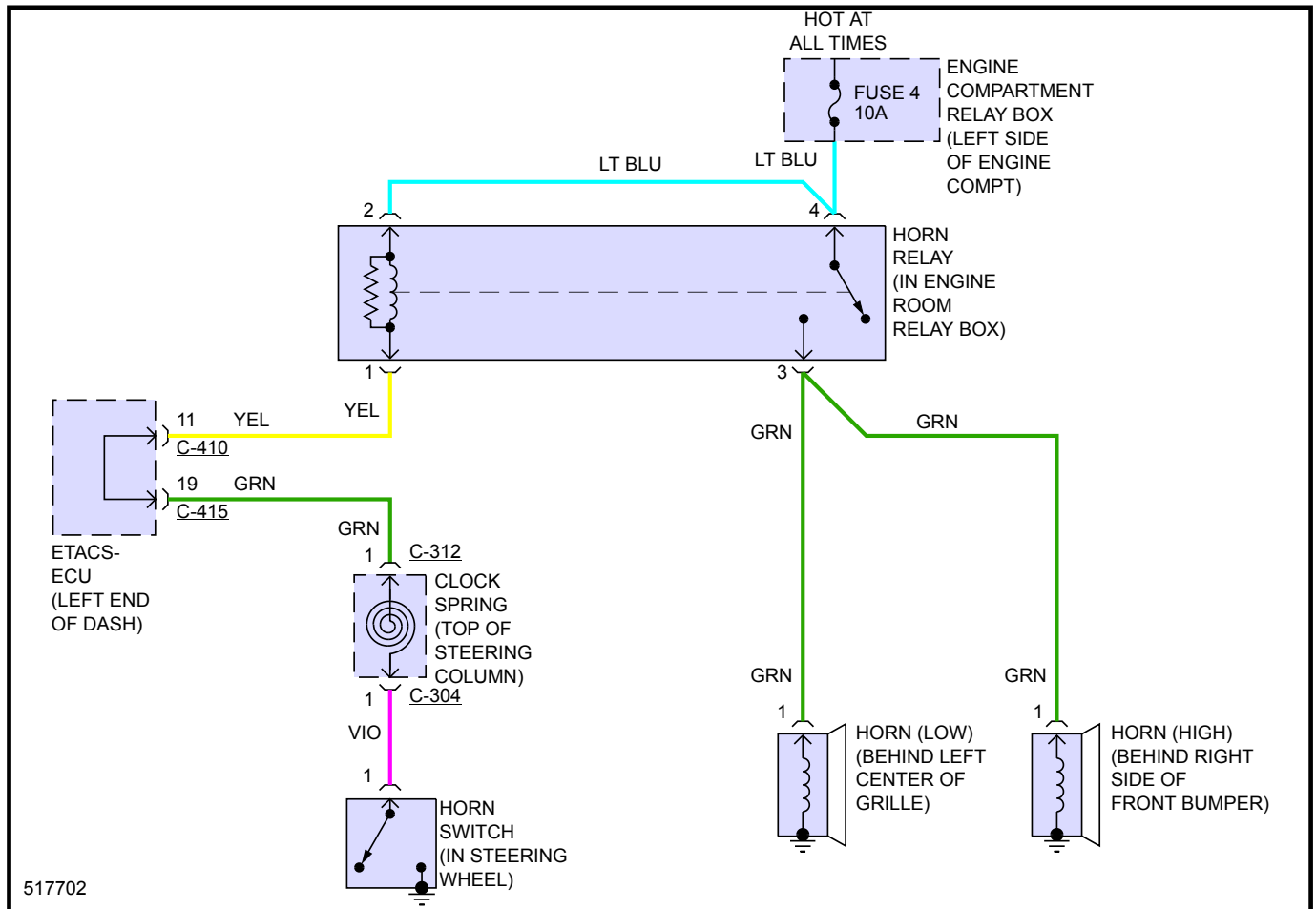

Fig 4: Headlights Circuit, W/O High Intensity Discharge (2 of 2)



HORN

Fig 1: Horn Circuit



INSTRUMENT CLUSTER

Fig 1: Instrument Cluster Circuit (1 of 2)

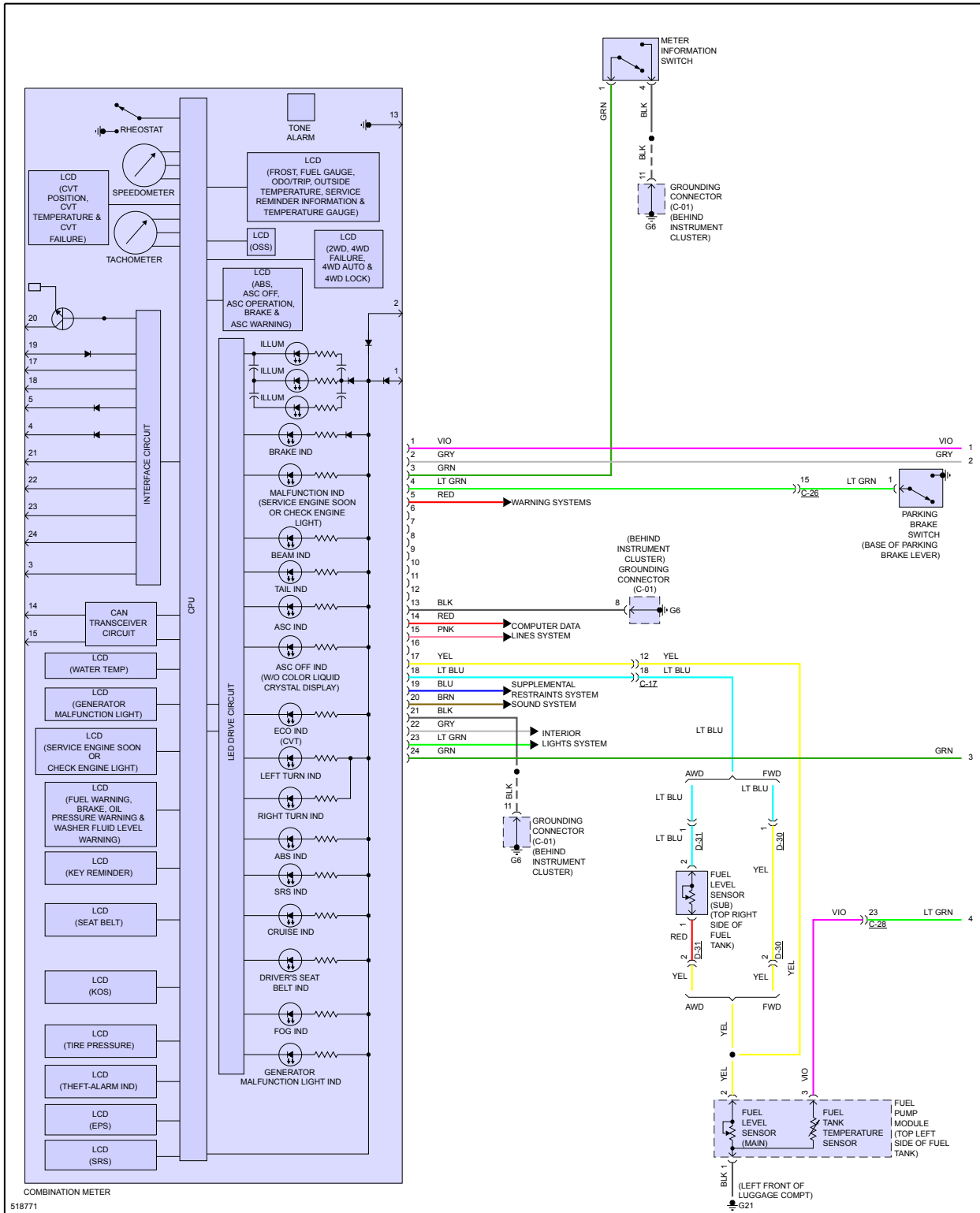
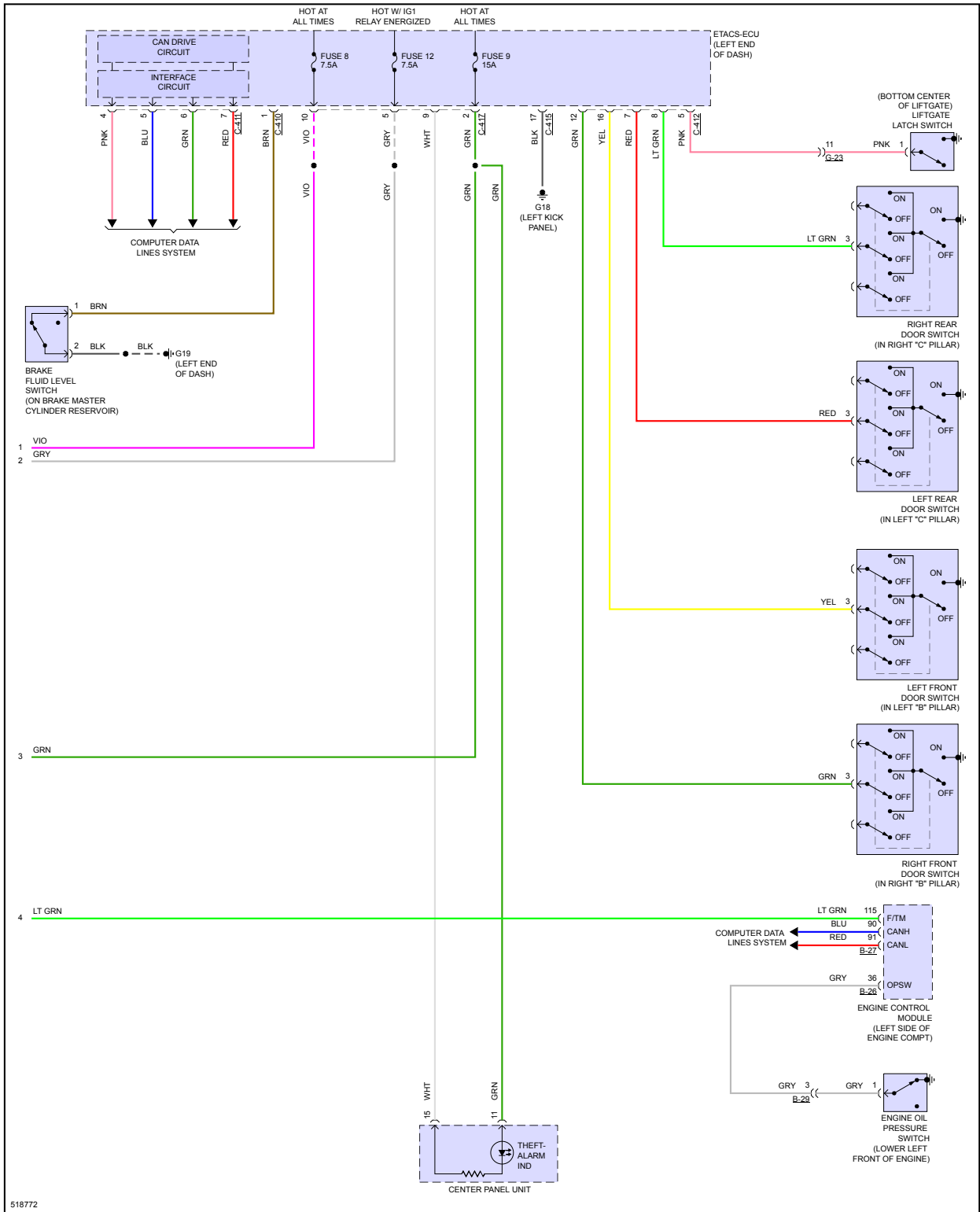

Fig 2: Instrument Cluster Circuit (2 of 2)



INTERIOR LIGHTS

Fig 1: Courtesy Lamps Circuit (1 of 2)

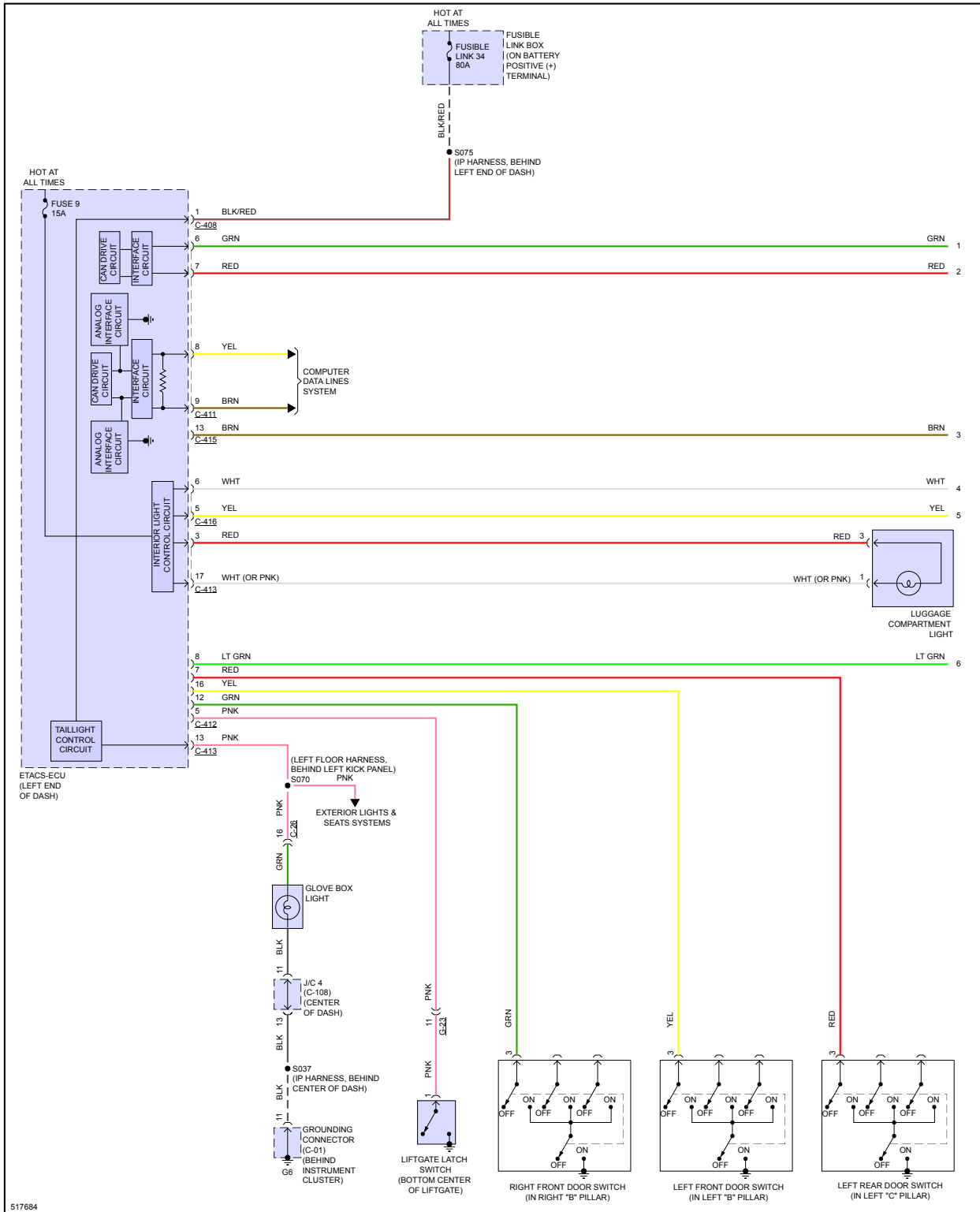

Fig 2: Courtesy Lamps Circuit (2 of 2)

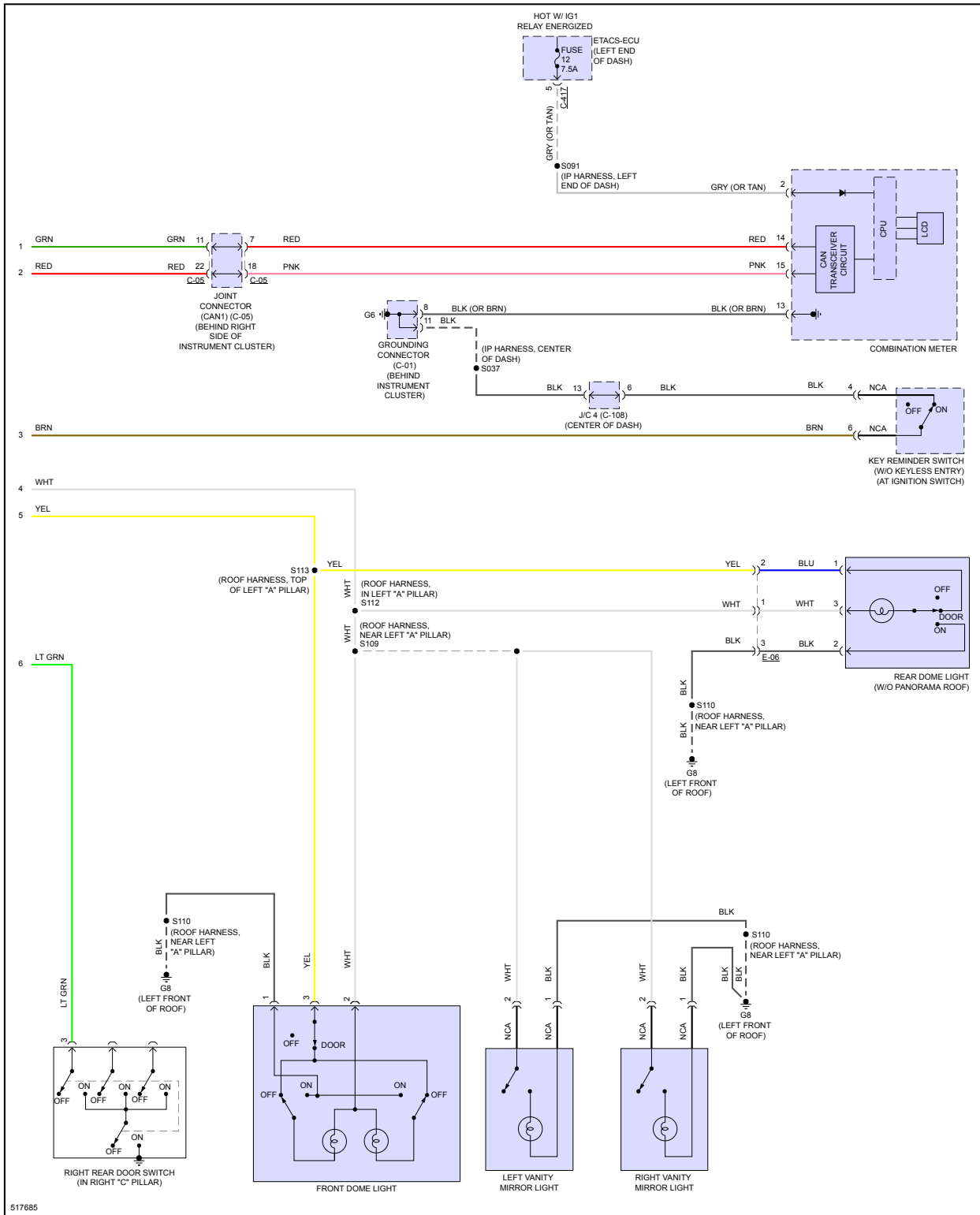
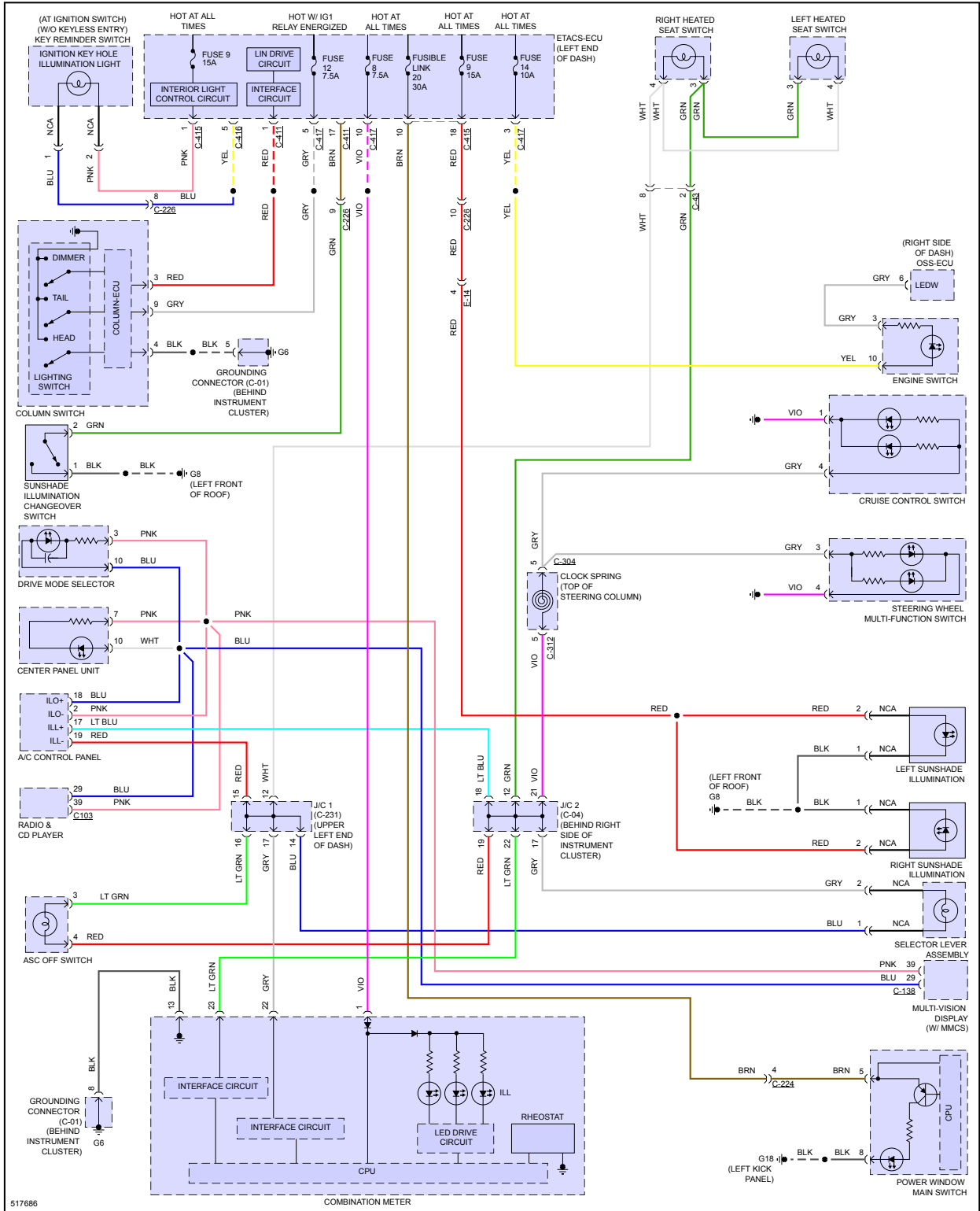

Fig 3: Instrument Illumination Circuit



NAVIGATION

Fig 1: Hands Free Module Circuit, W/ Multi-Communication System

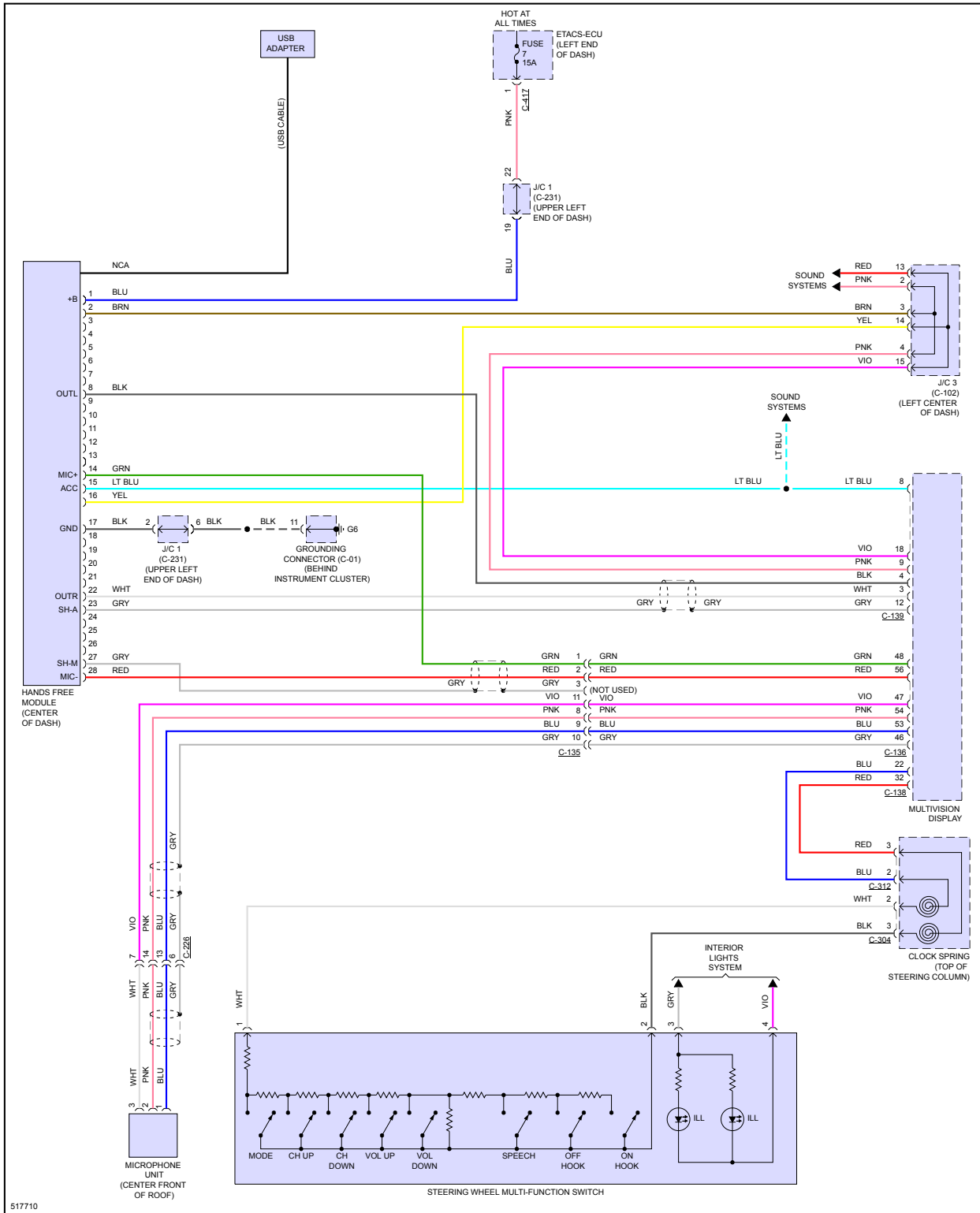

Fig 2: Hands Free Module Circuit, W/O Multi-Communication System

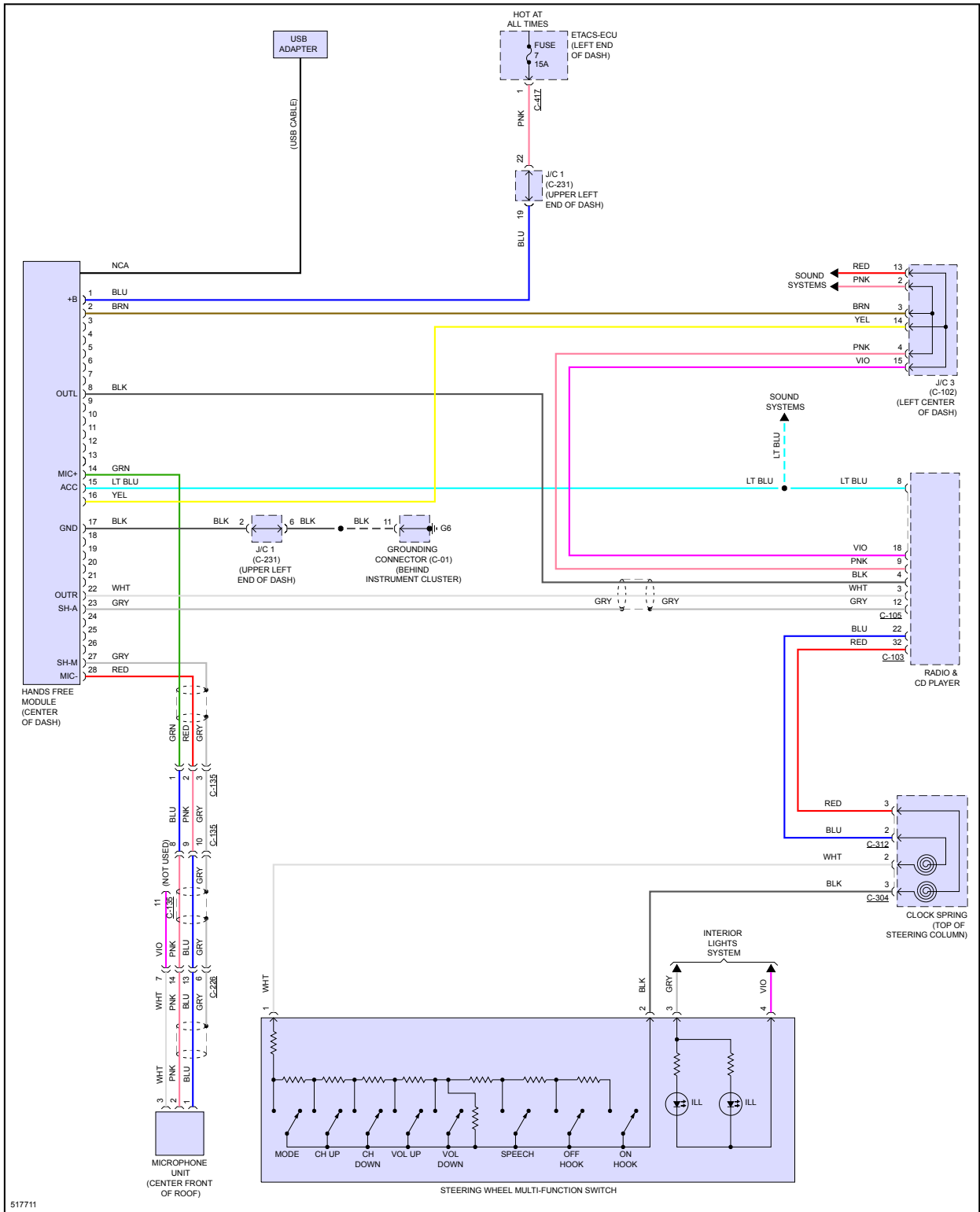

Fig 3: Navigation Circuit, W/ Amplifier (1 of 3)

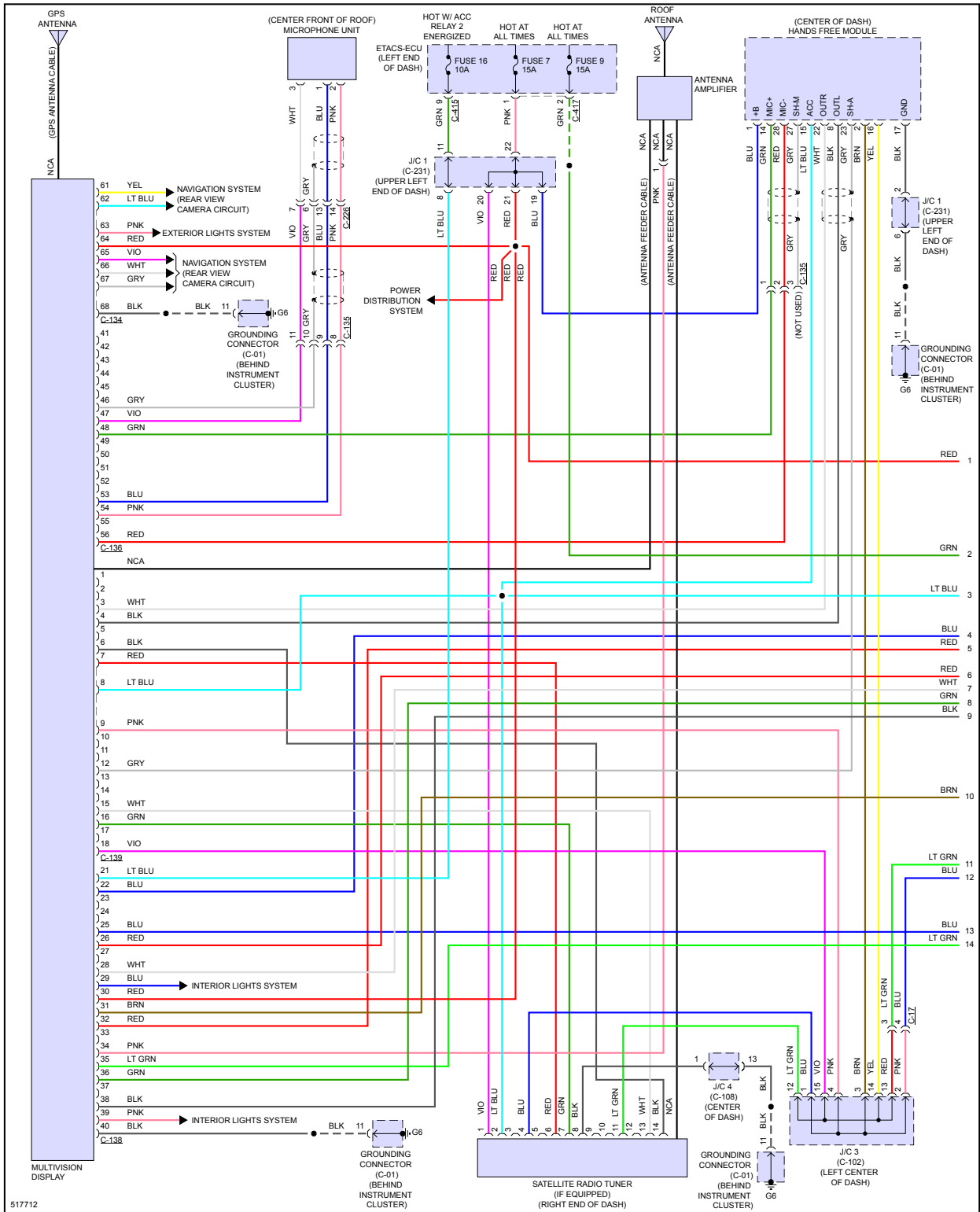

Fig 4: Navigation Circuit, W/ Amplifier (2 of 3)

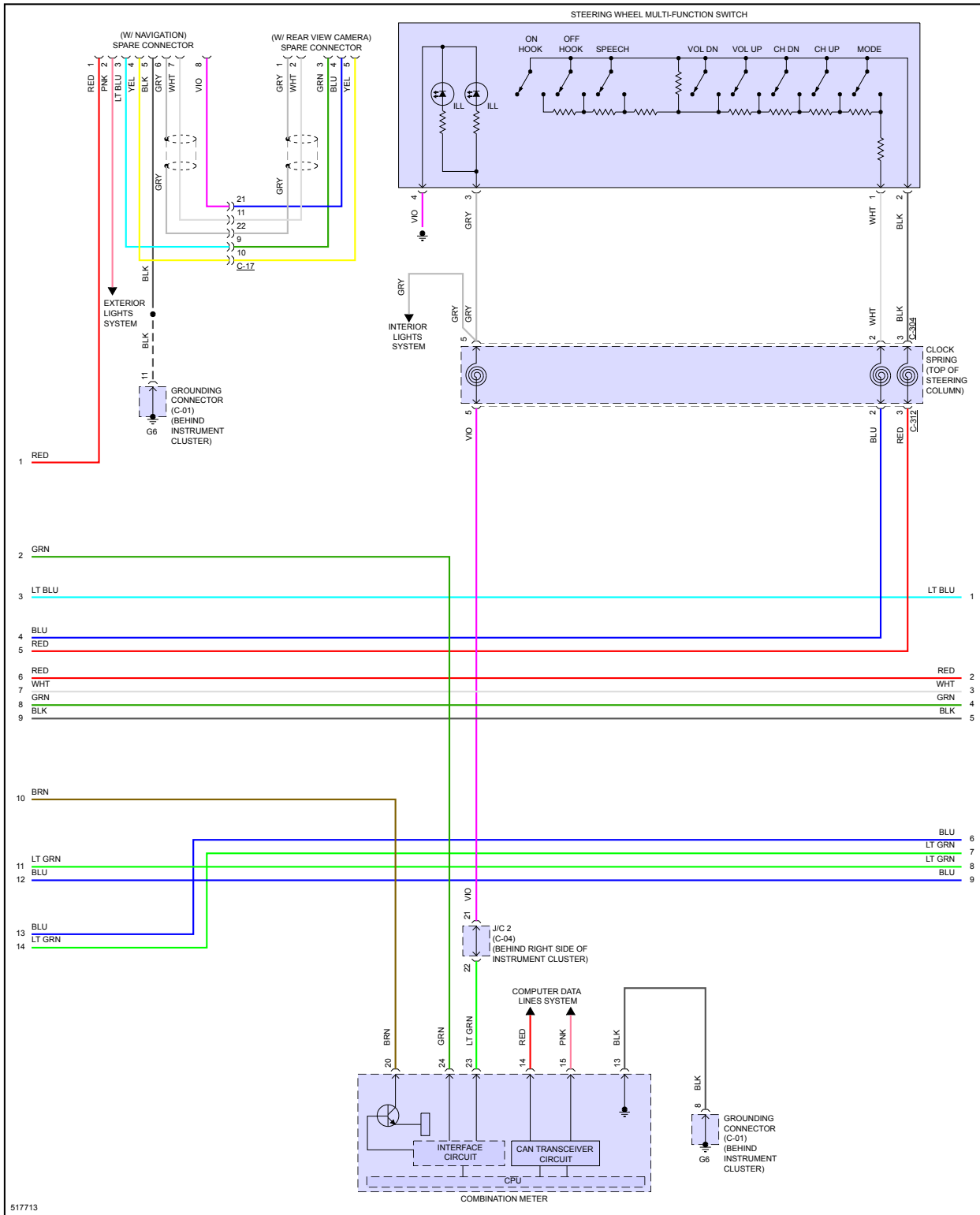

Fig 5: Navigation Circuit, W/ Amplifier (3 of 3)

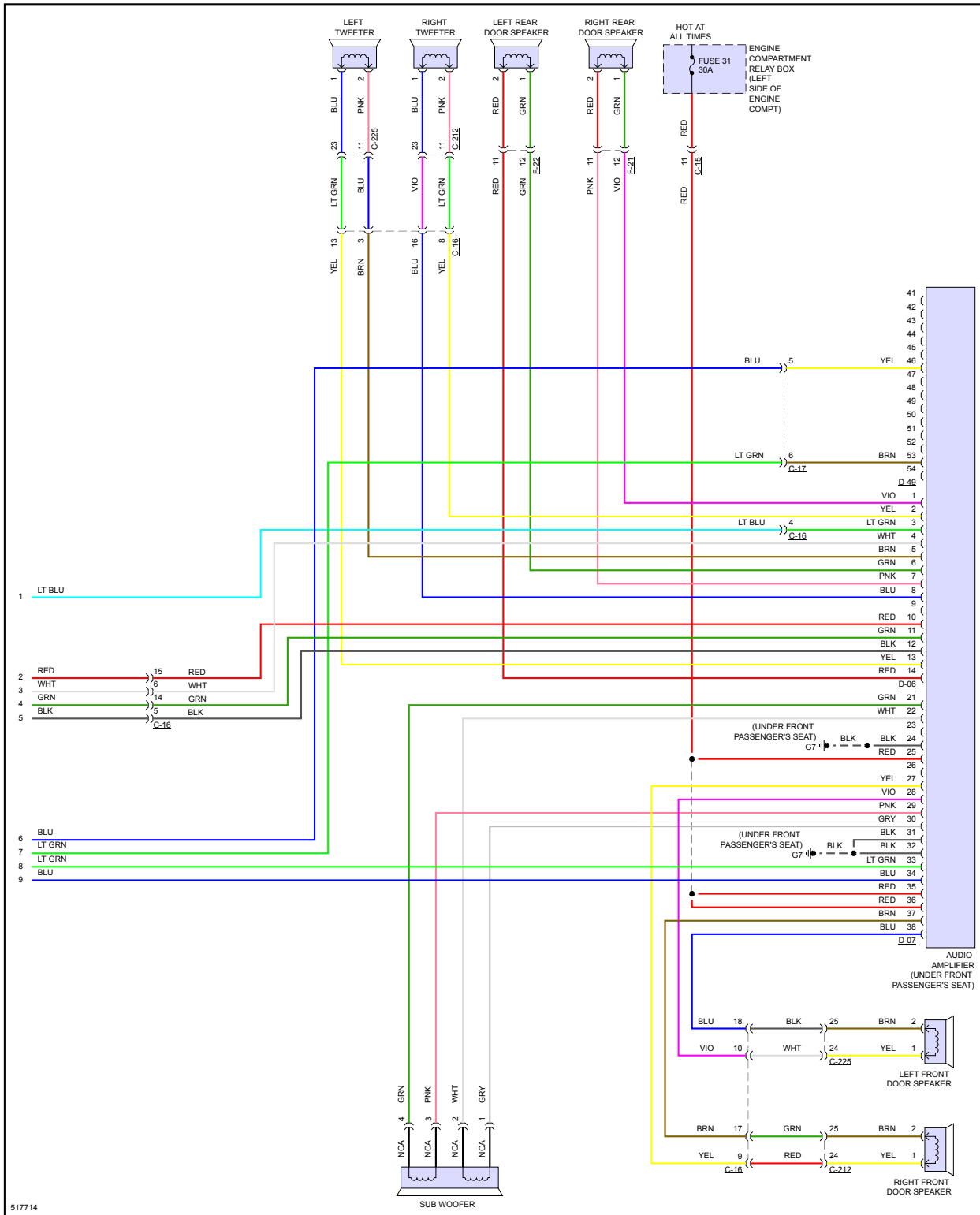

Fig 6: Navigation Circuit, W/O Amplifier (1 of 2)

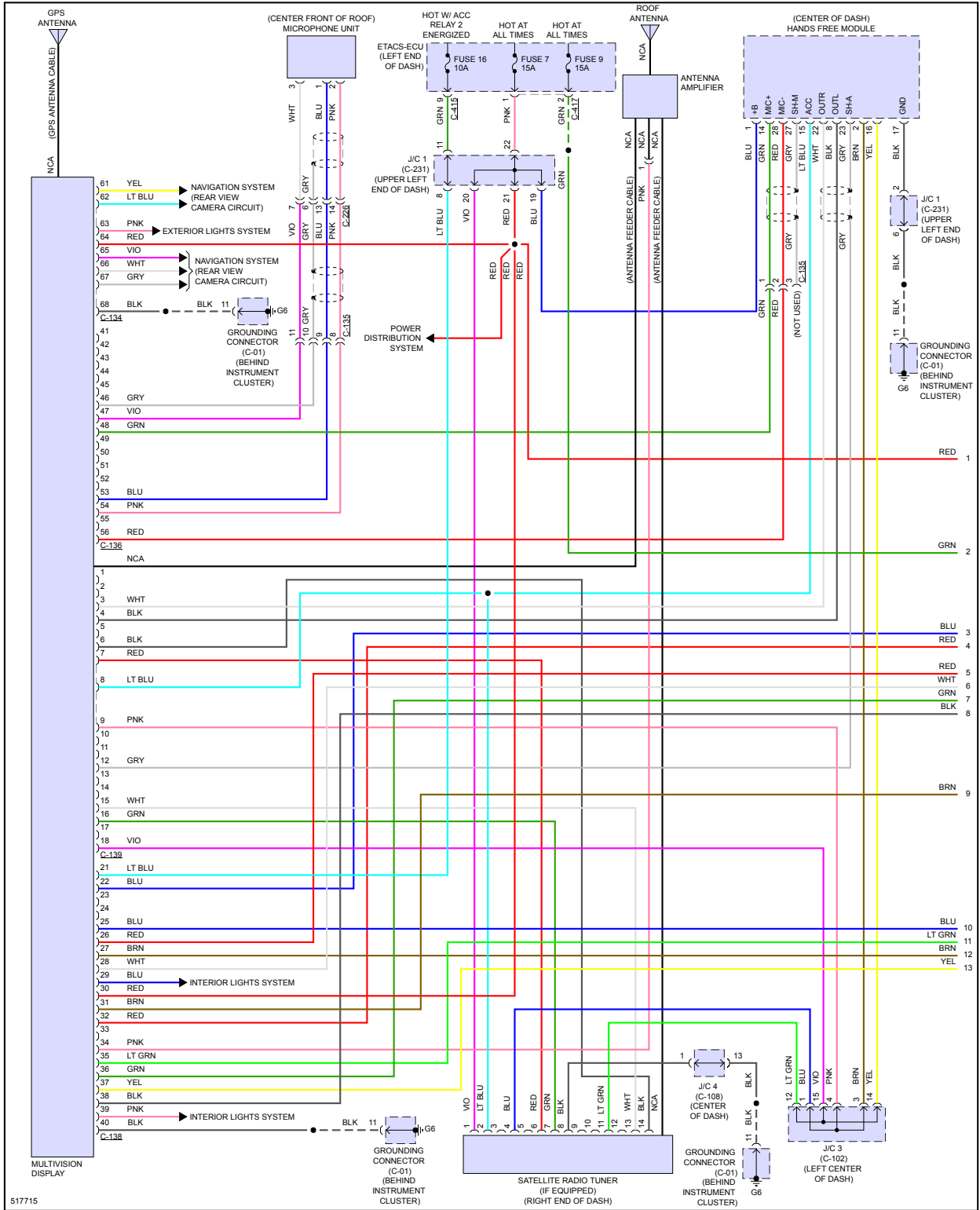

Fig 7: Navigation Circuit, W/O Amplifier (2 of 2)

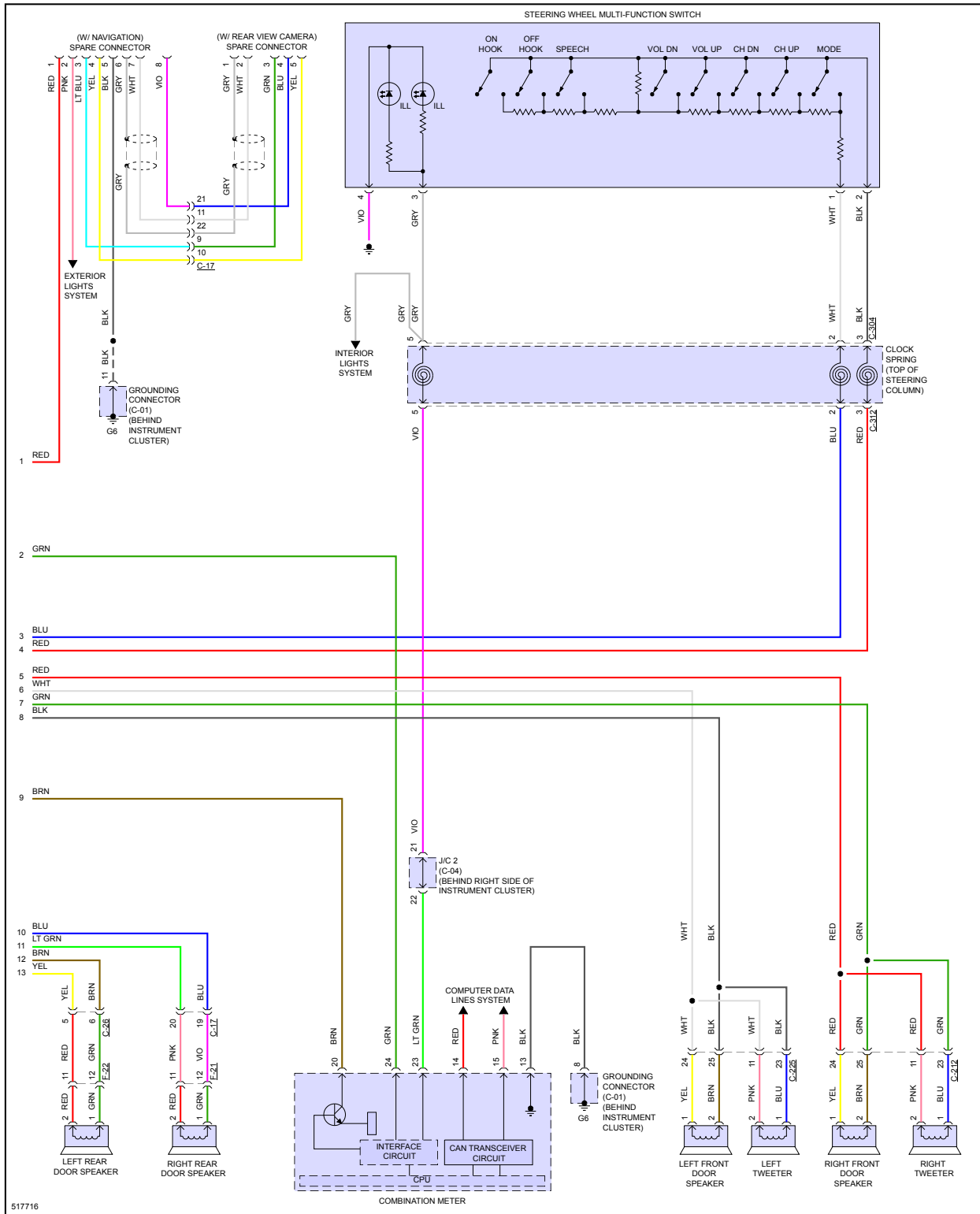

Fig 8: Rear View Camera Circuit, W/ Multi-Communication System

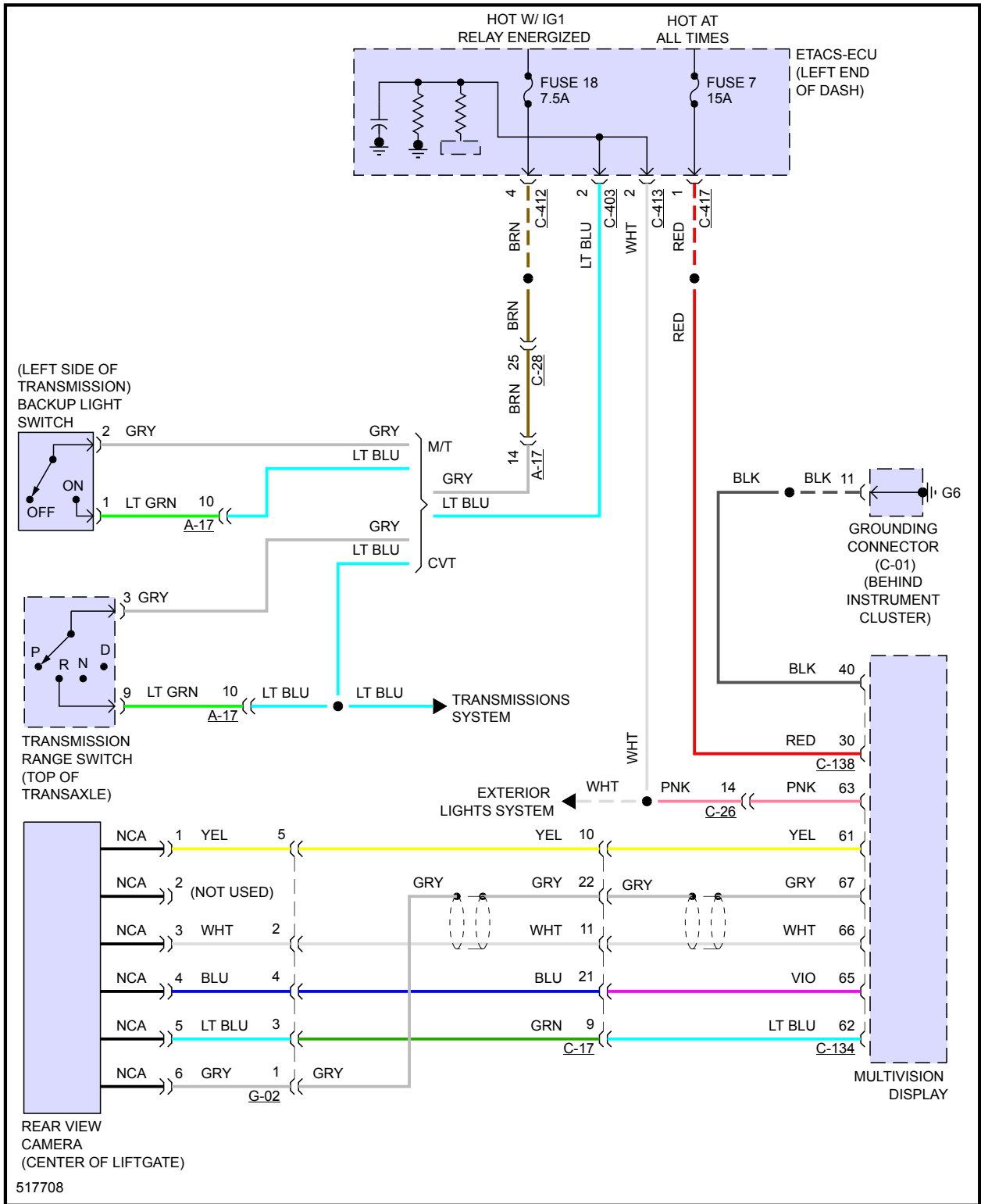
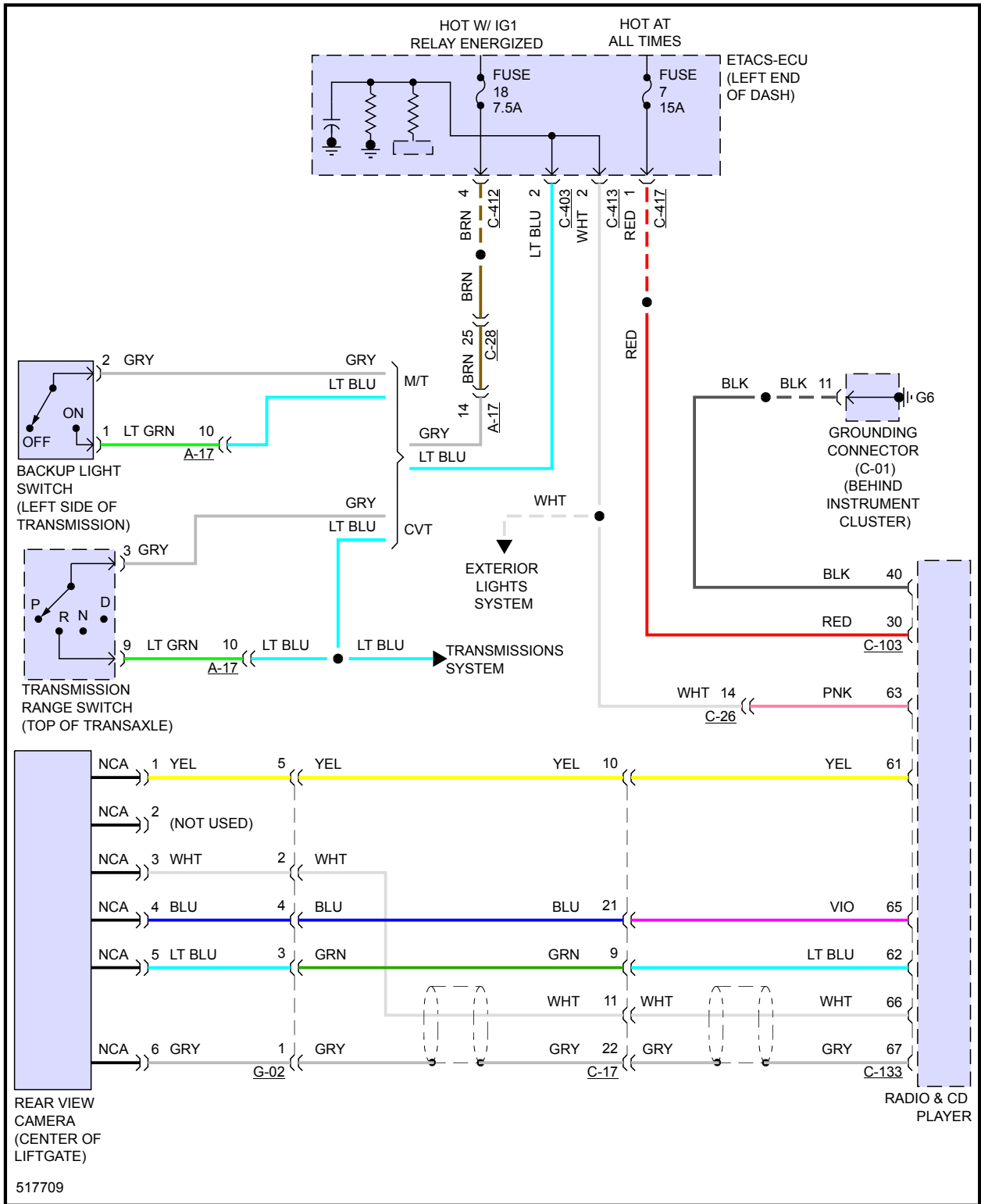

Fig 9: Rear View Camera Circuit, W/O Multi-Communication System



POWER DISTRIBUTION

Fig 1: Power Distribution Circuit (1 of 2)

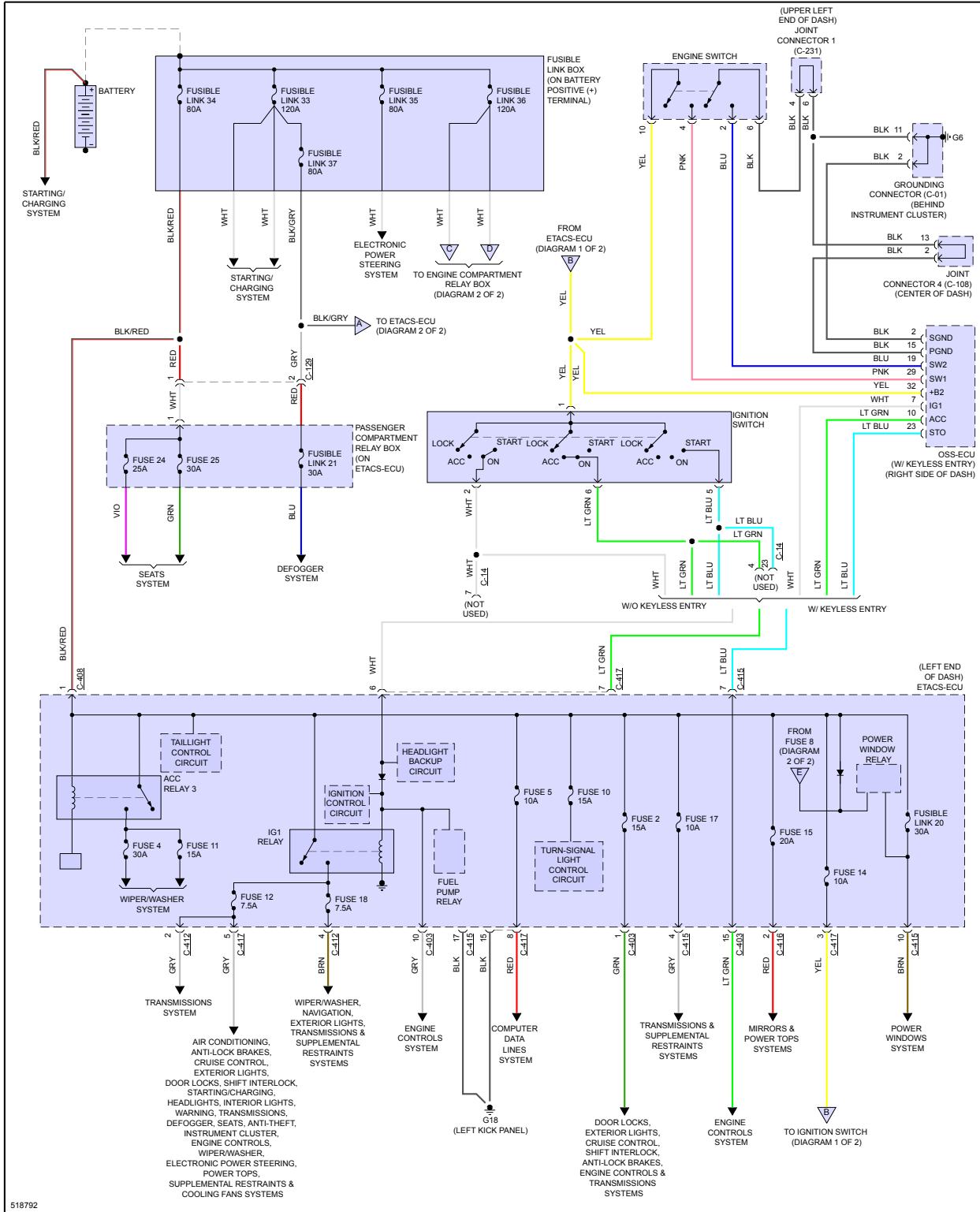
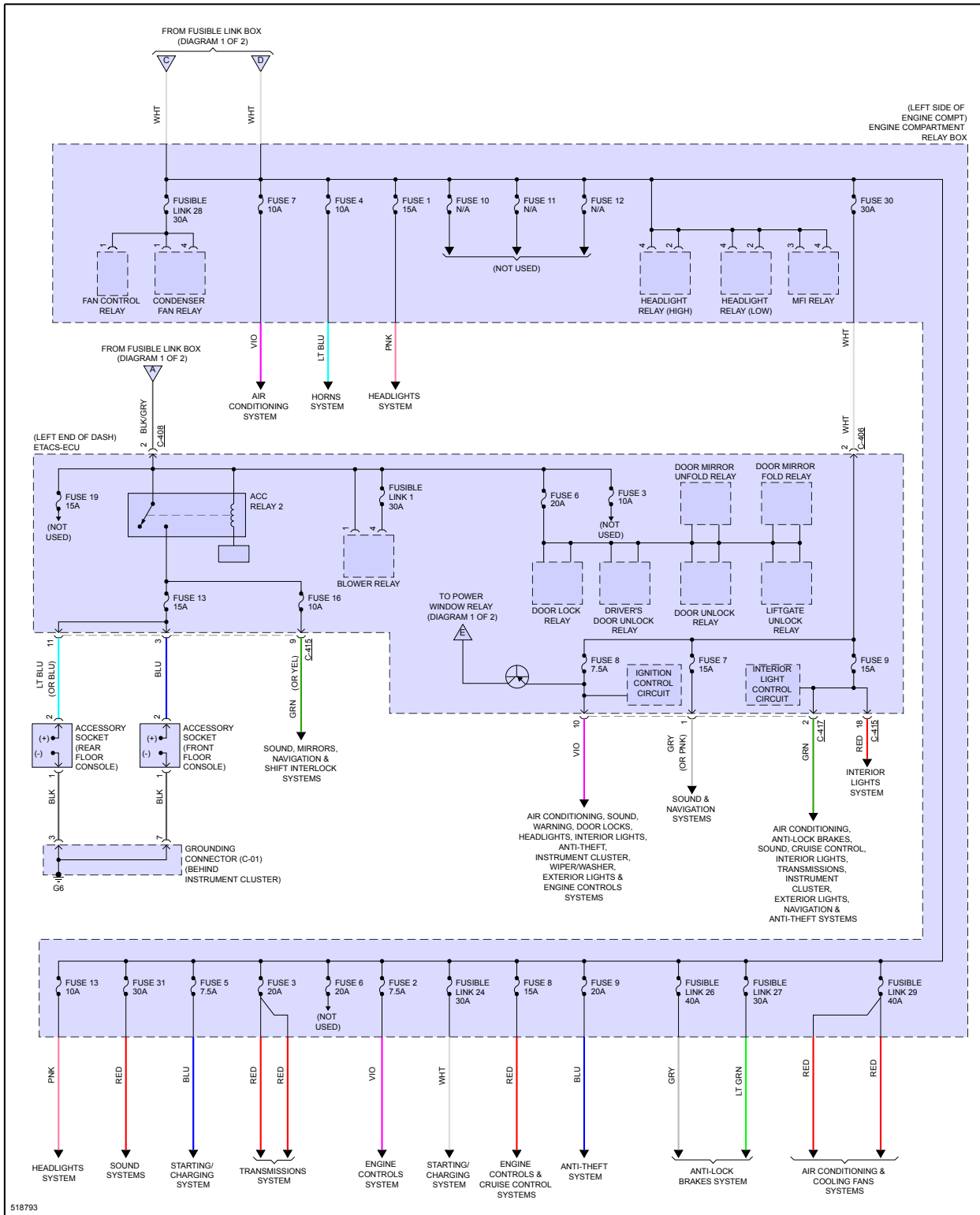

Fig 2: Power Distribution Circuit (2 of 2)



POWER DOOR LOCKS

Fig 1: Power Door Locks Circuit, W/ Keyless Entry (1 of 4)

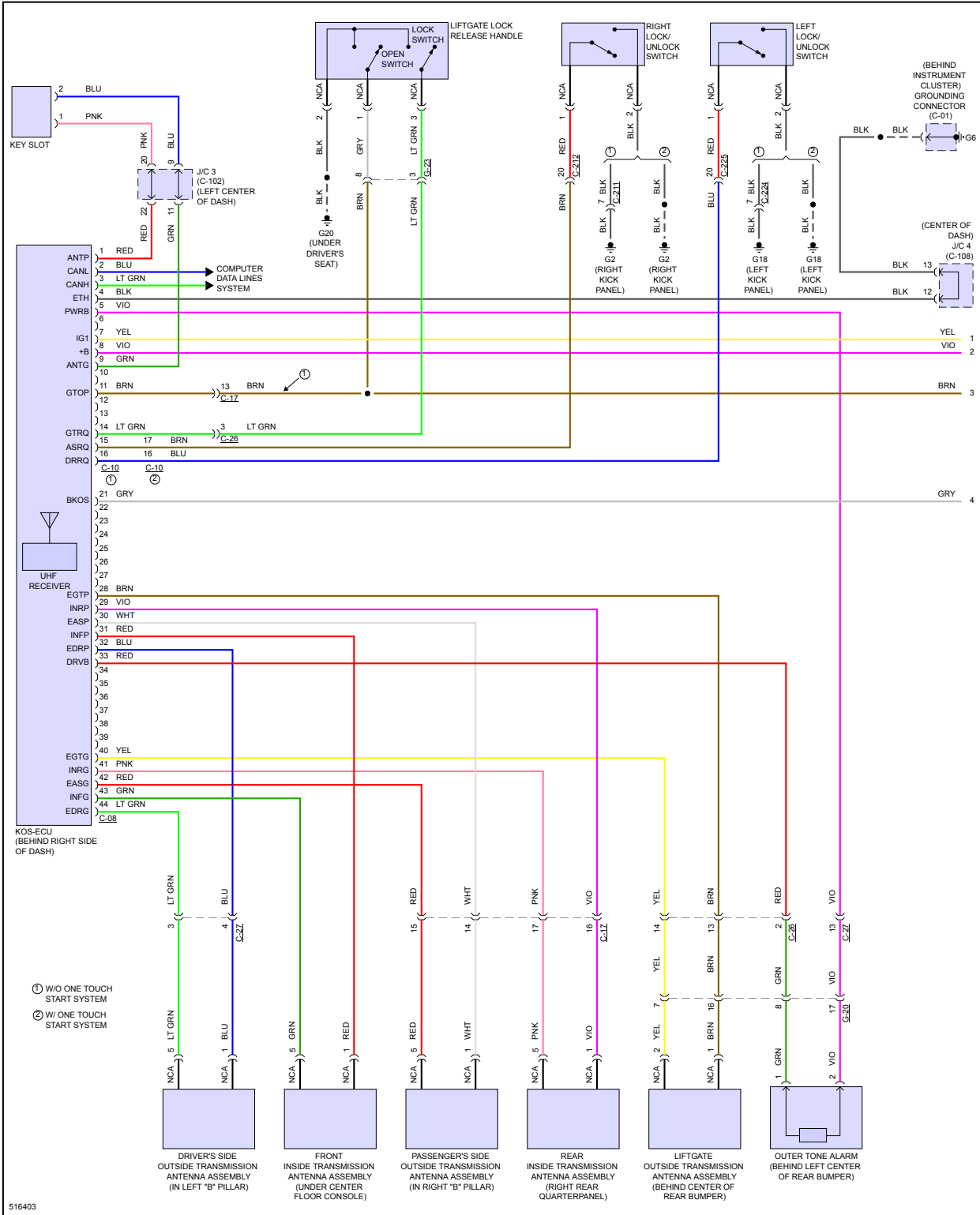

Fig 2: Power Door Locks Circuit, W/ Keyless Entry (2 of 4)

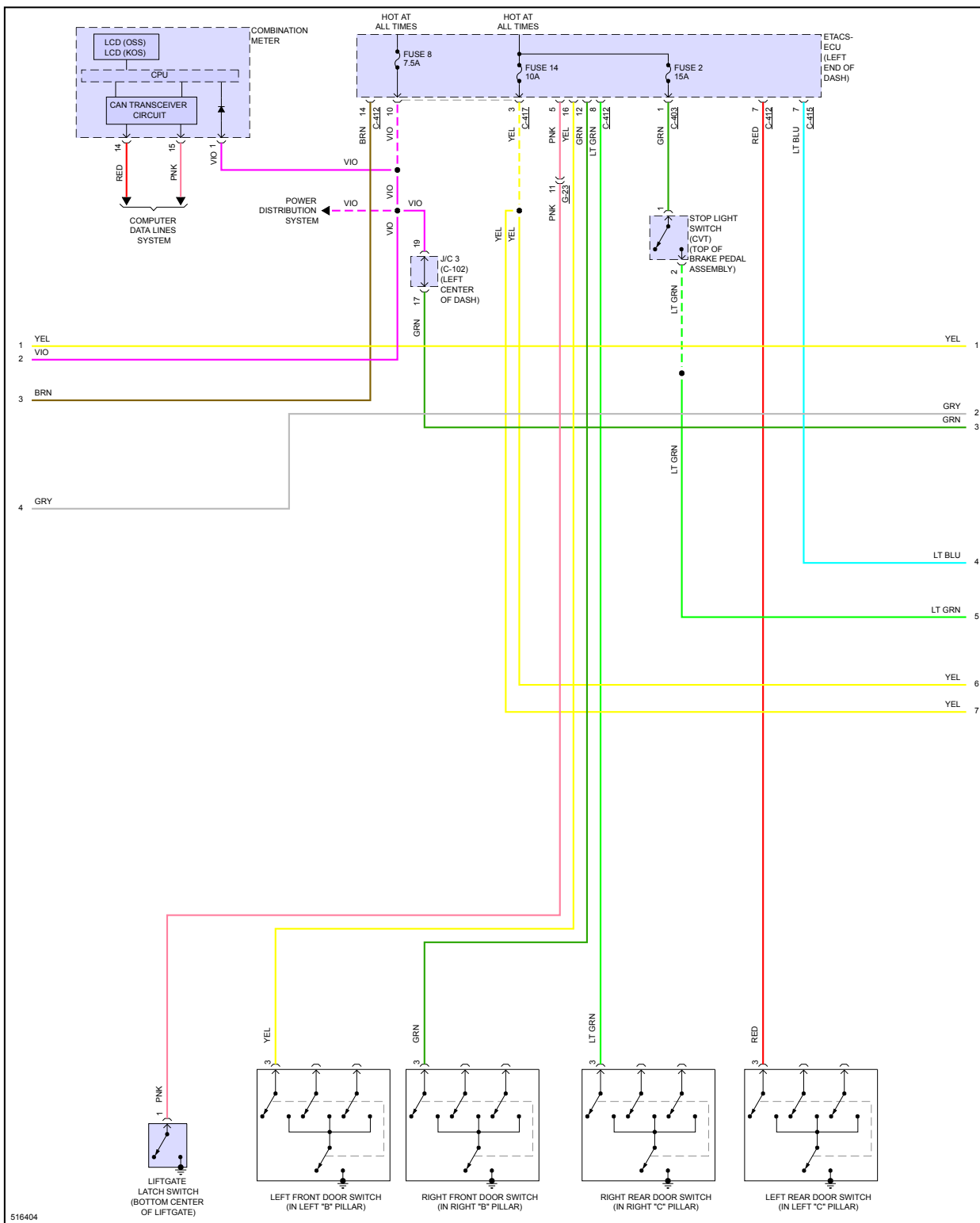

Fig 3: Power Door Locks Circuit, W/ Keyless Entry (3 of 4)

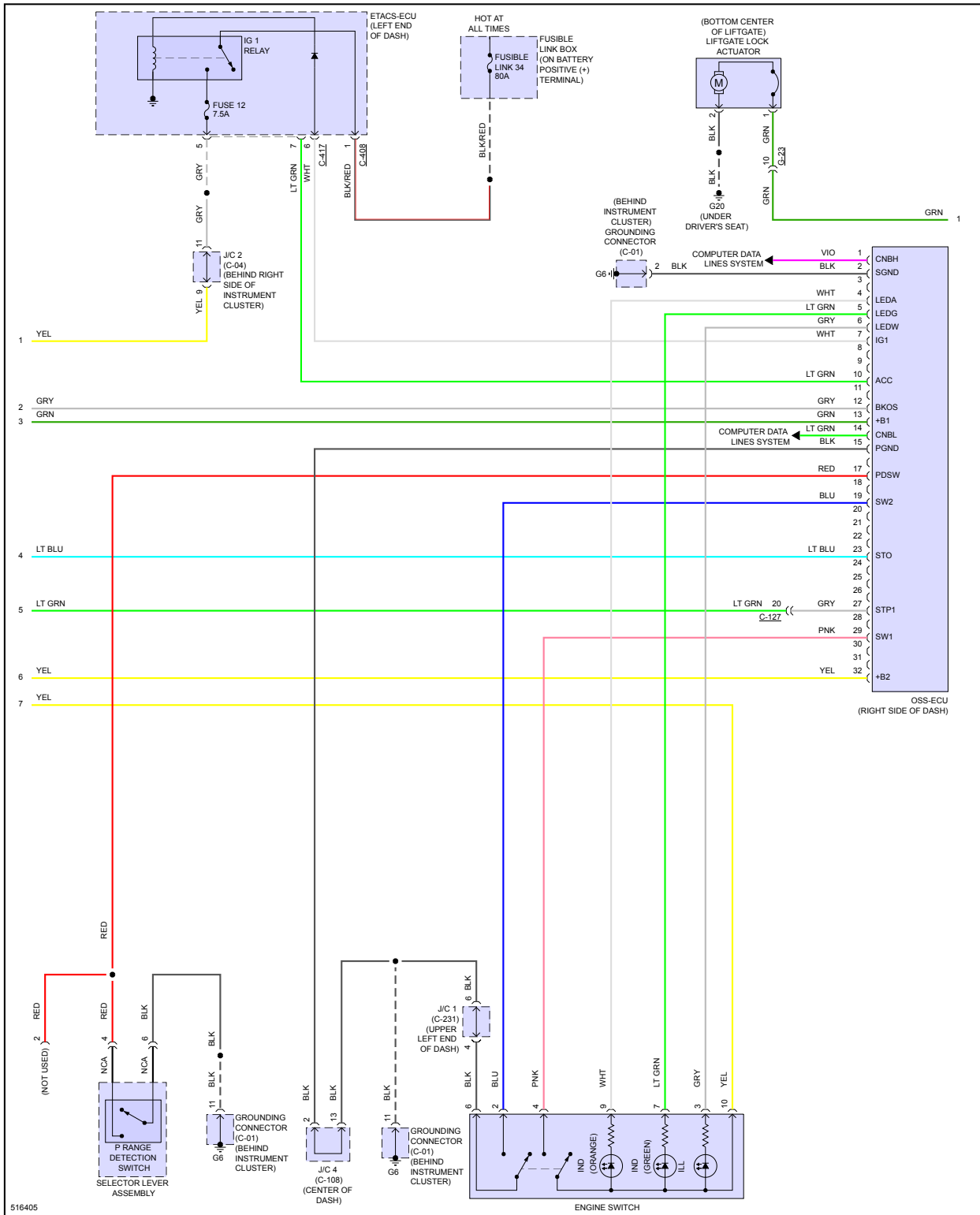
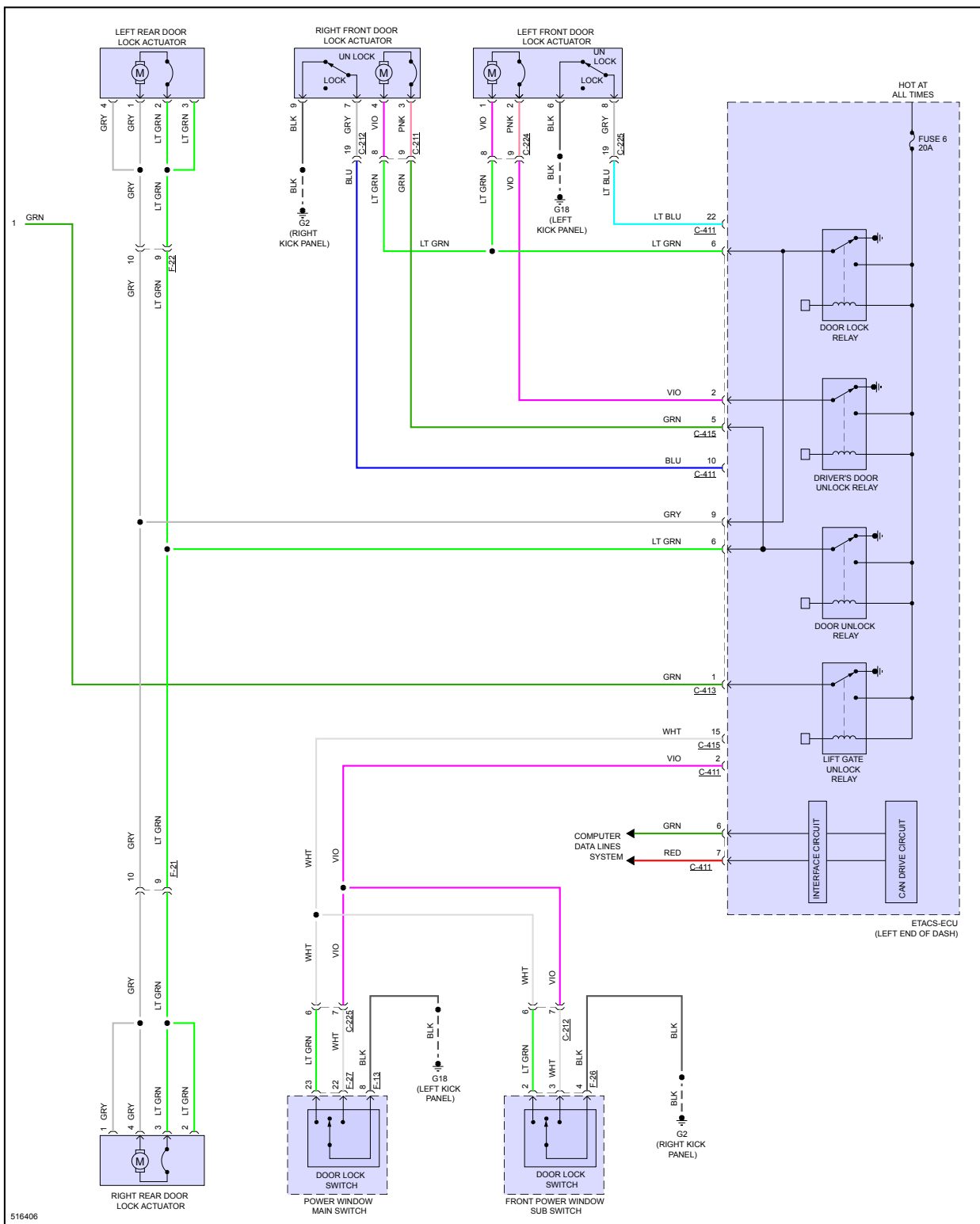

Fig 4: Power Door Locks Circuit, W/ Keyless Entry (4 of 4)



516406

Fig 5: Power Door Locks Circuit, W/O Keyless Entry (1 of 2)

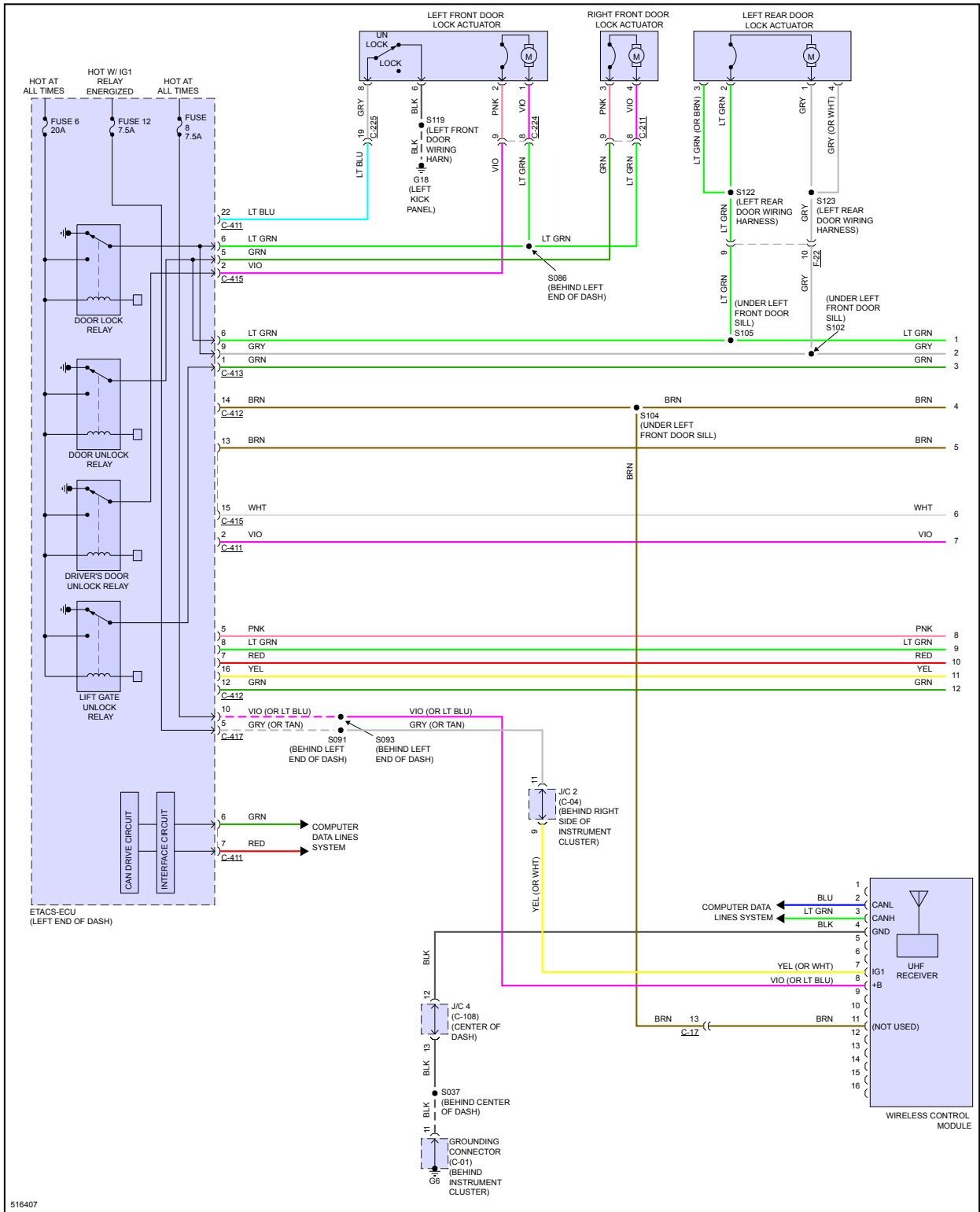
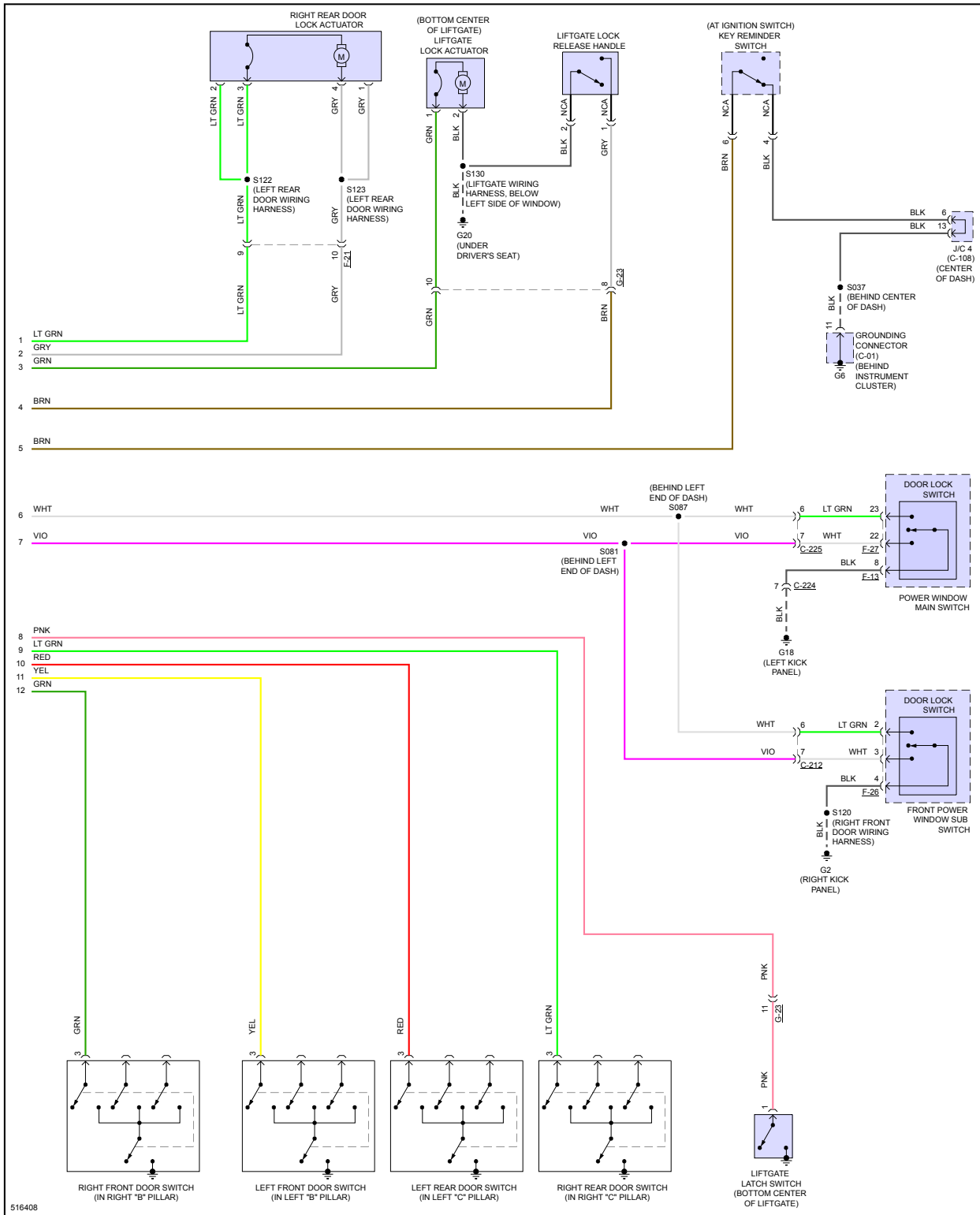

Fig 6: Power Door Locks Circuit, W/O Keyless Entry (2 of 2)



POWER MIRRORS

Fig 1: Automatic Day/Night Mirror Circuit, W/ Universal Garage Door Opener

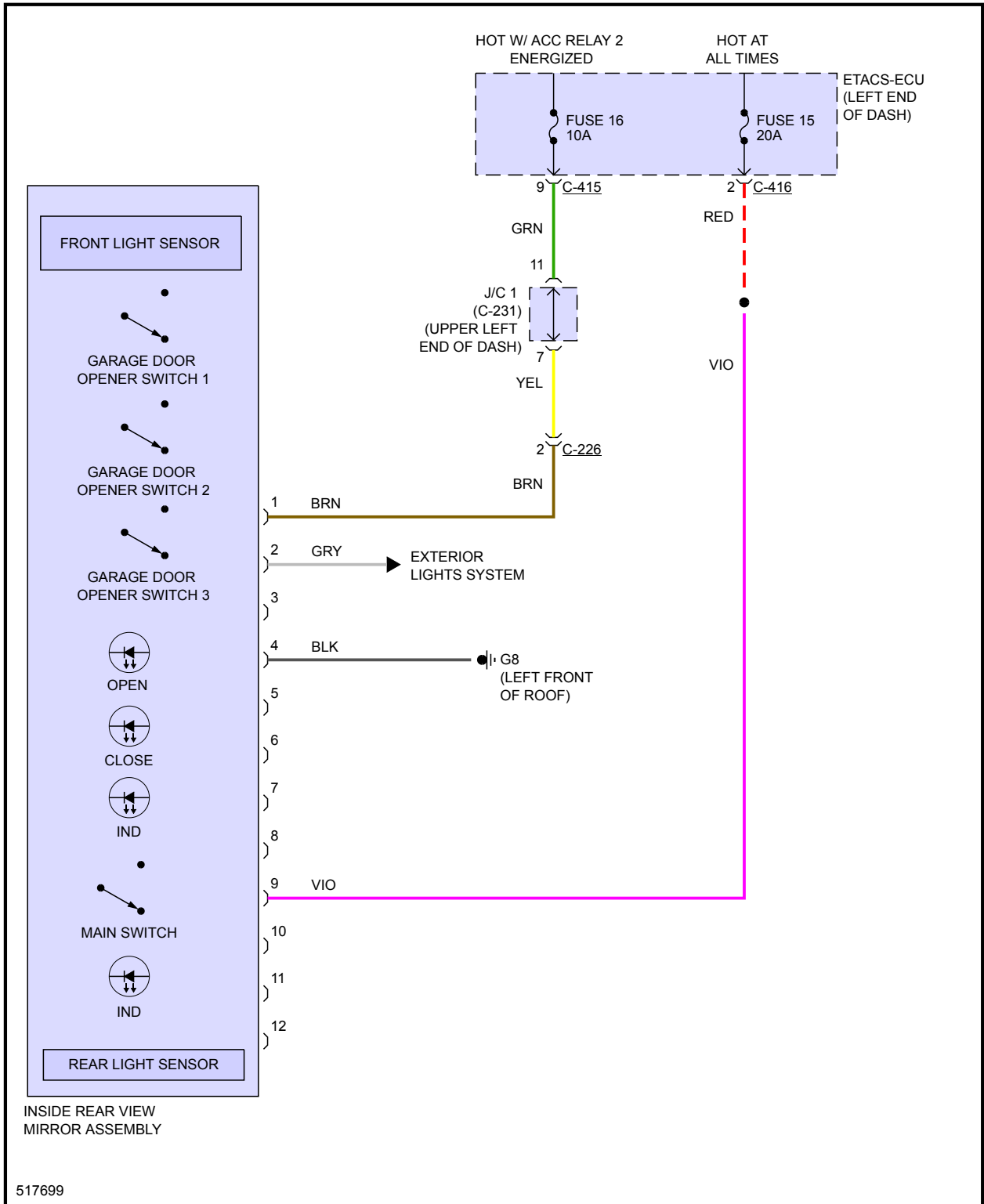

Fig 2: Automatic Day/Night Mirror Circuit, W/O Universal Garage Door Opener

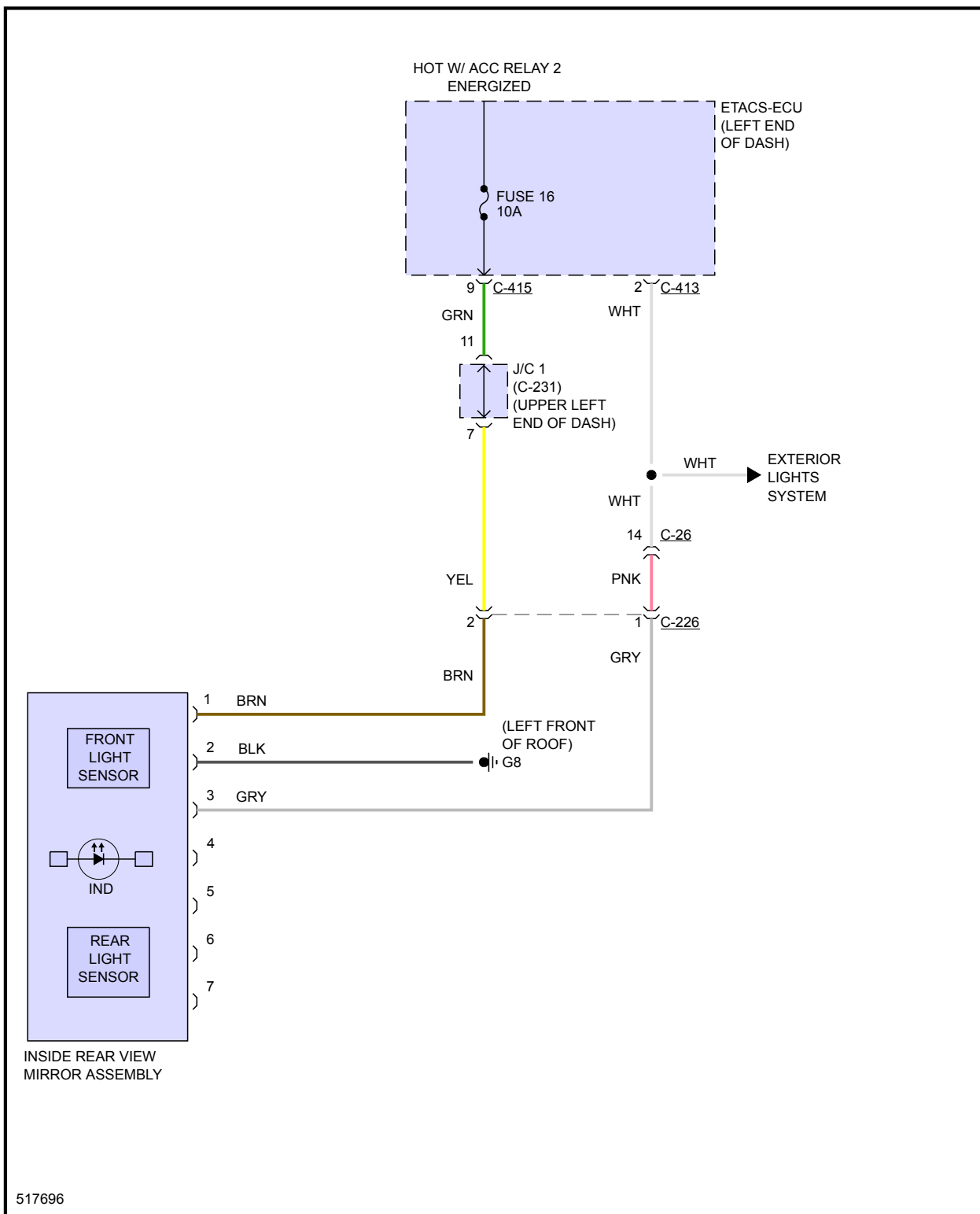

Fig 3: Fold-back Mirrors Circuit

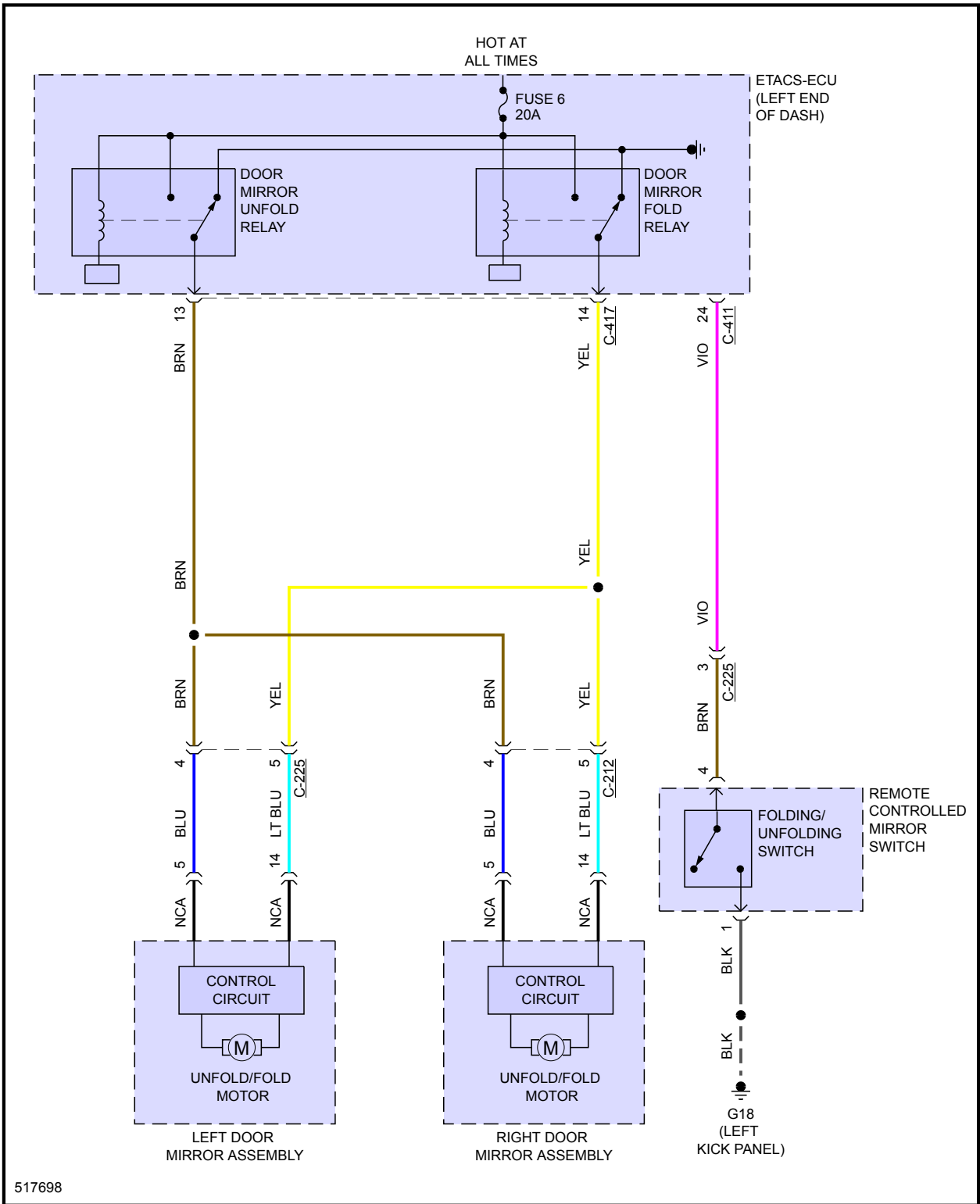
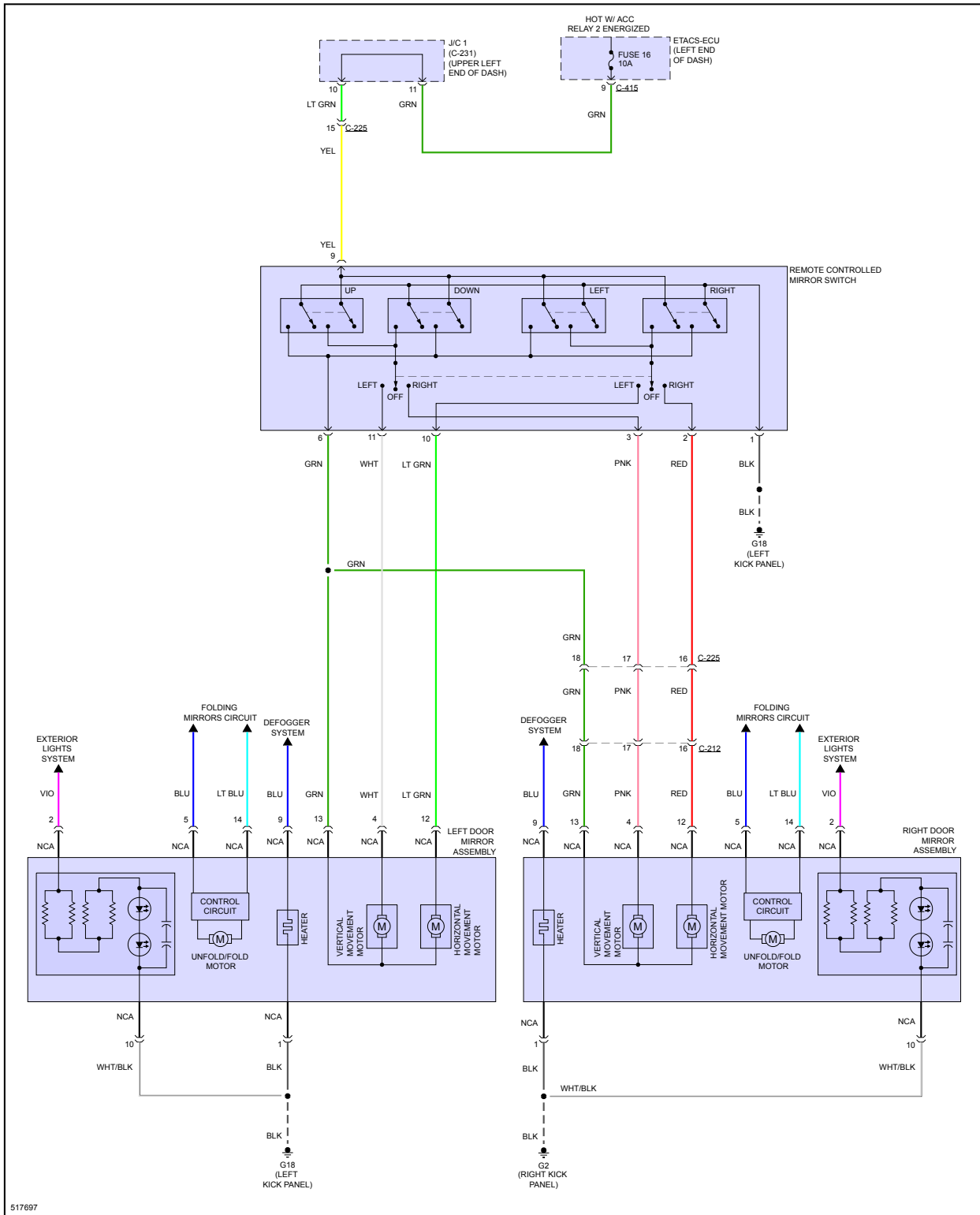

Fig 4: Power Mirrors Circuit



POWER SEATS

Fig 1: Heated Seats Circuit

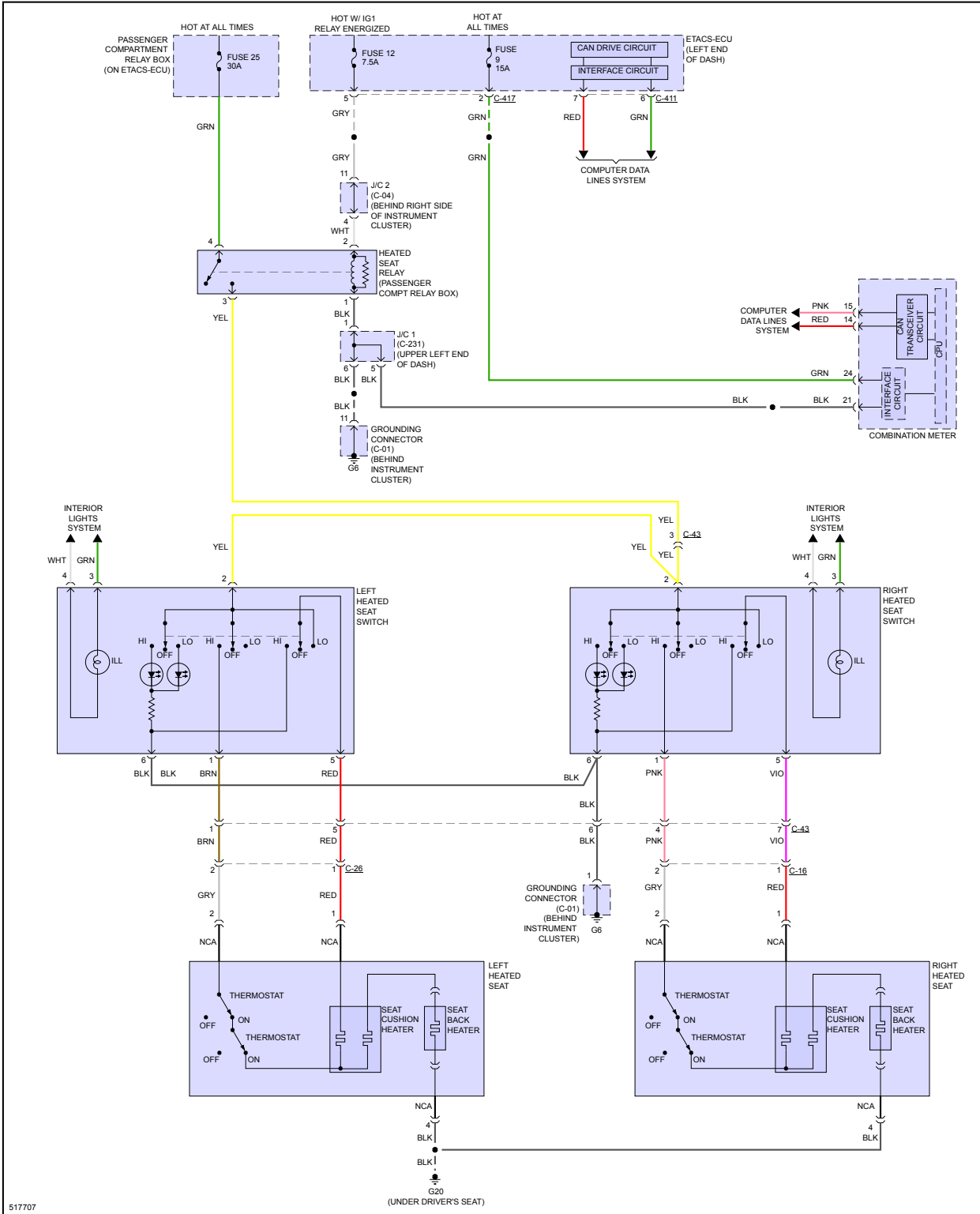
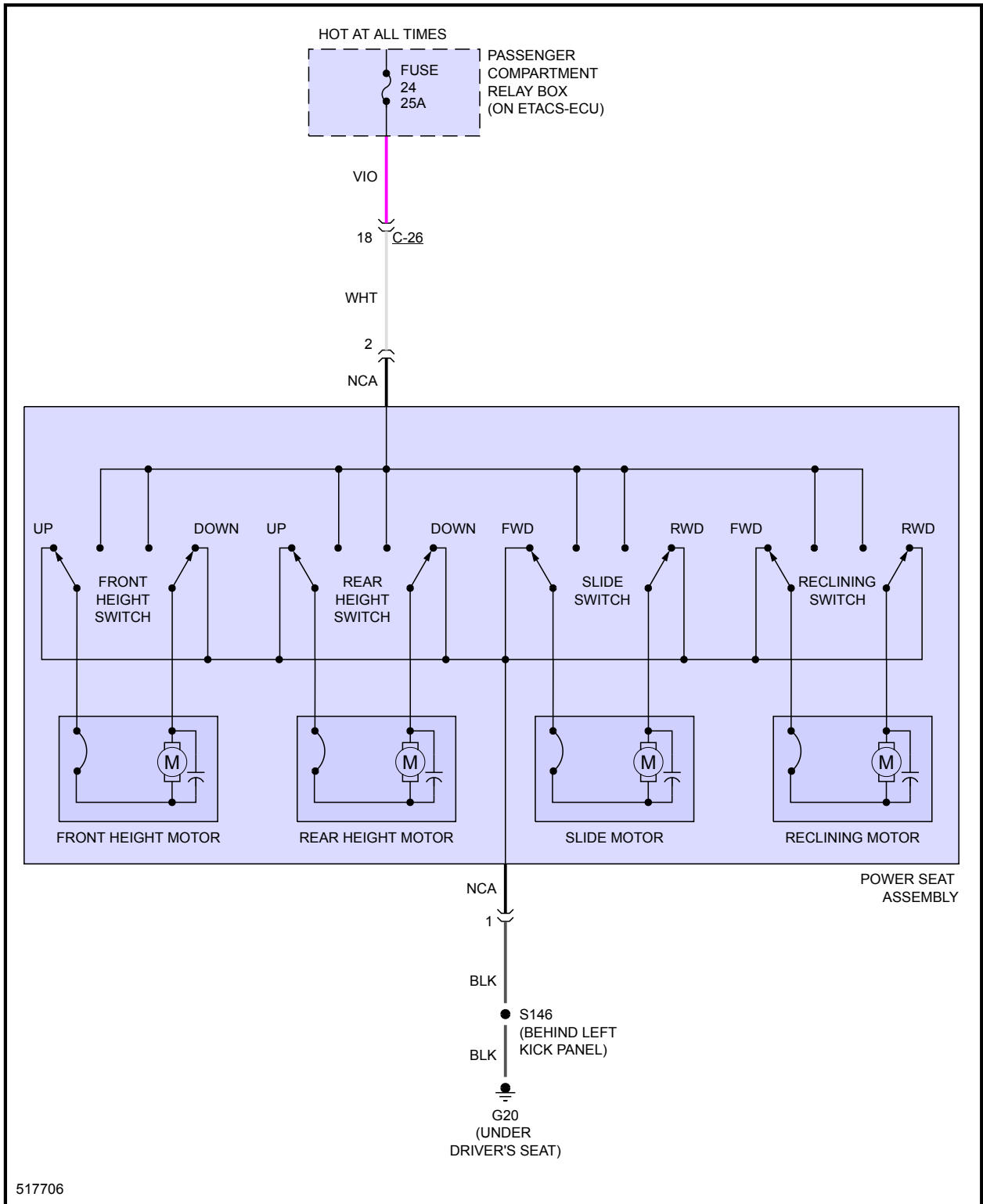
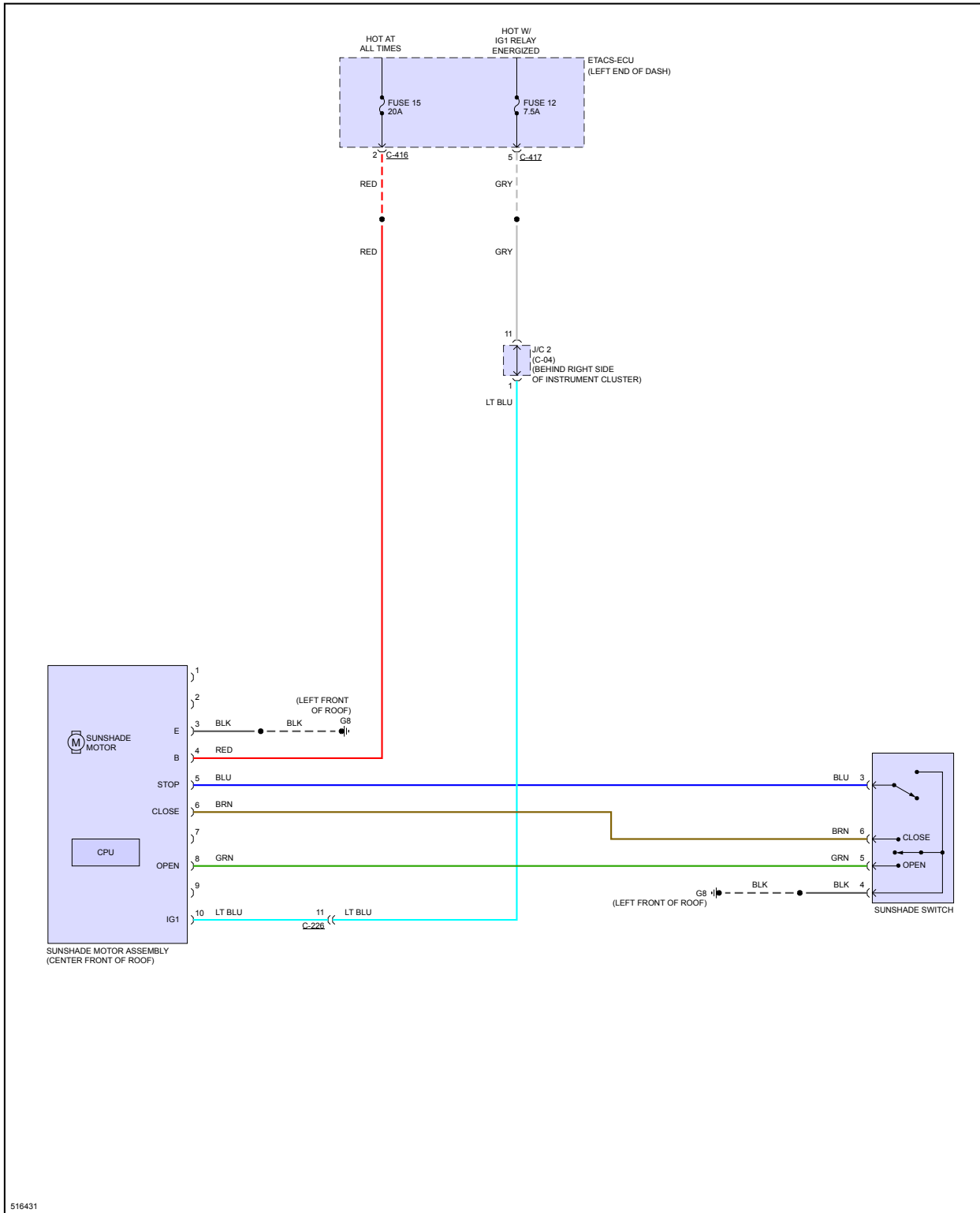

Fig 2: Power Seats Circuit



POWER TOP/SUNROOF

Fig 1: Power Top/Sunroof Circuit



POWER WINDOWS

Fig 1: Power Windows Circuit

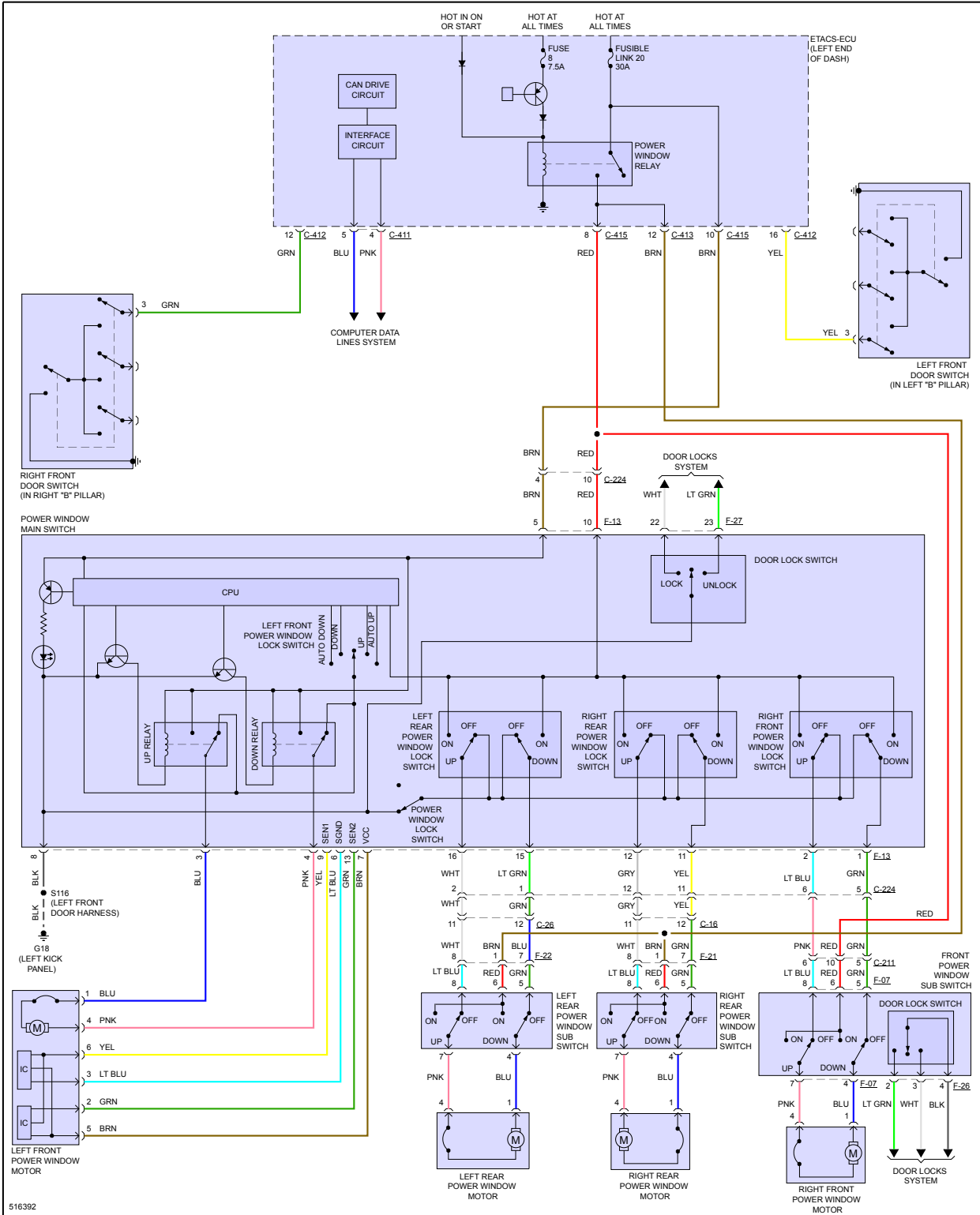

RADIO

Fig 1: Radio Circuit, W/ Multi-Communication System W/ Amplifier (1 of 3)

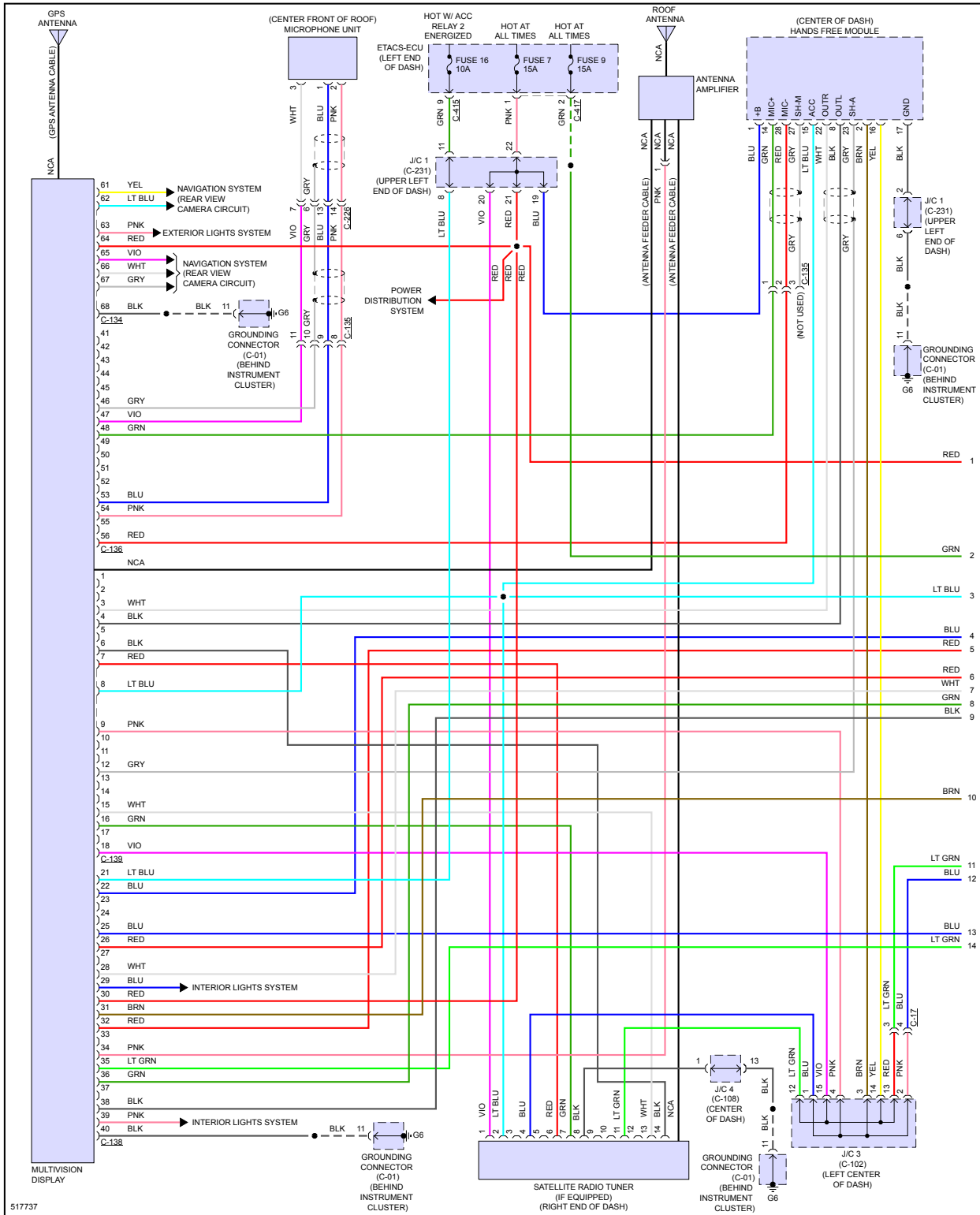

Fig 2: Radio Circuit, W/ Multi-Communication System W/ Amplifier (2 of 3)

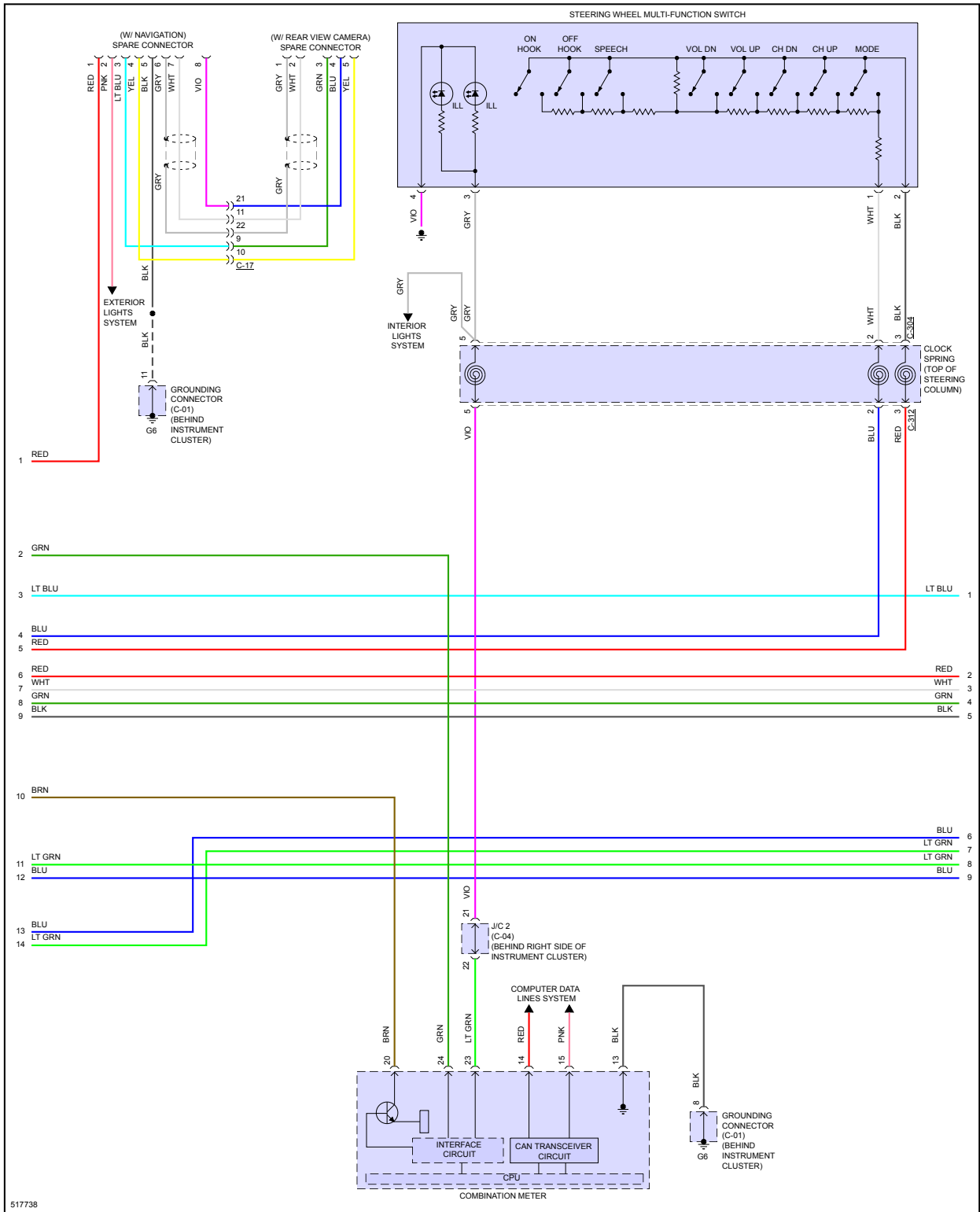

Fig 3: Radio Circuit, W/ Multi-Communication System W/ Amplifier (3 of 3)

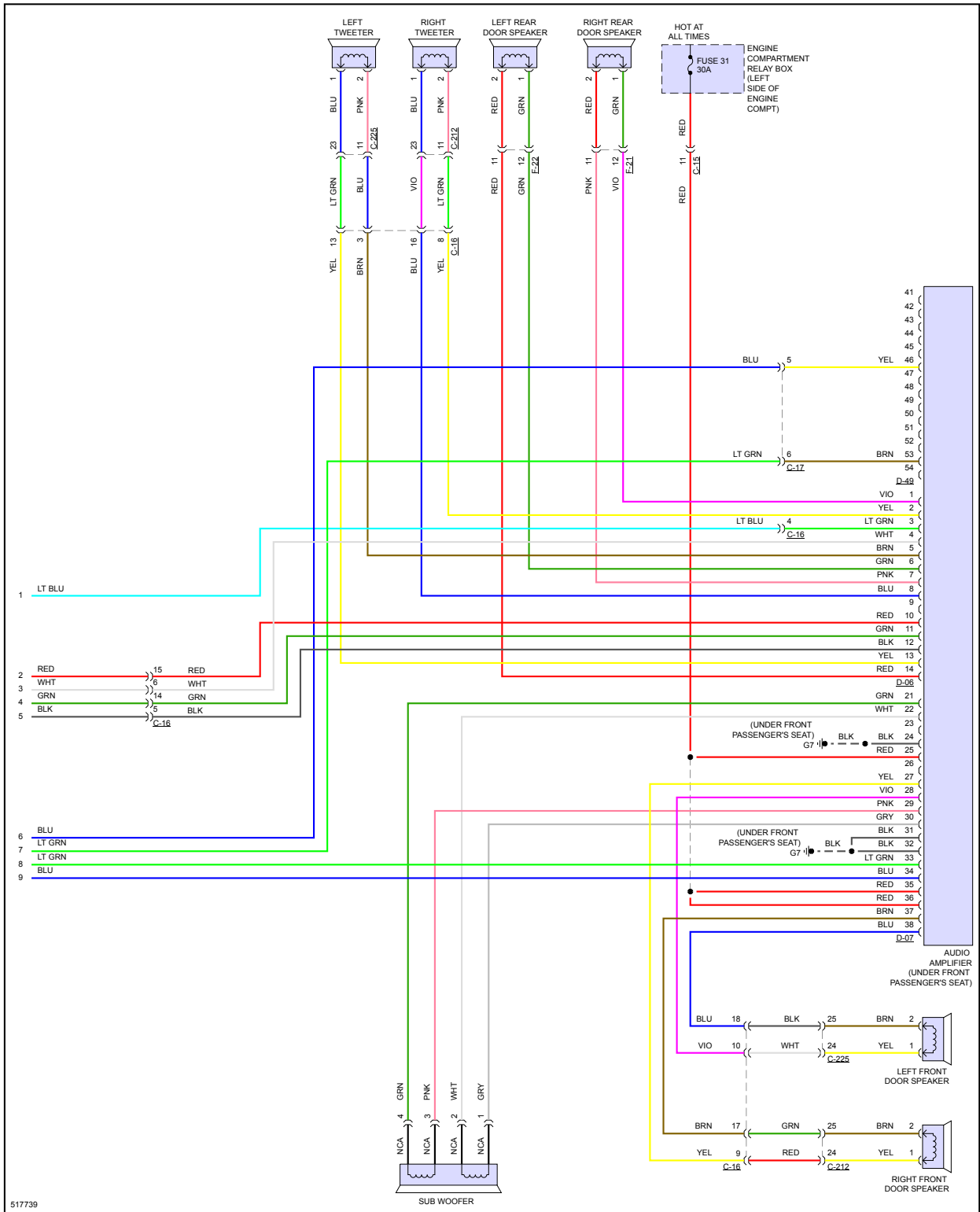

Fig 4: Radio Circuit, W/ Multi-Communication System W/O Amplifier (1 of 2)

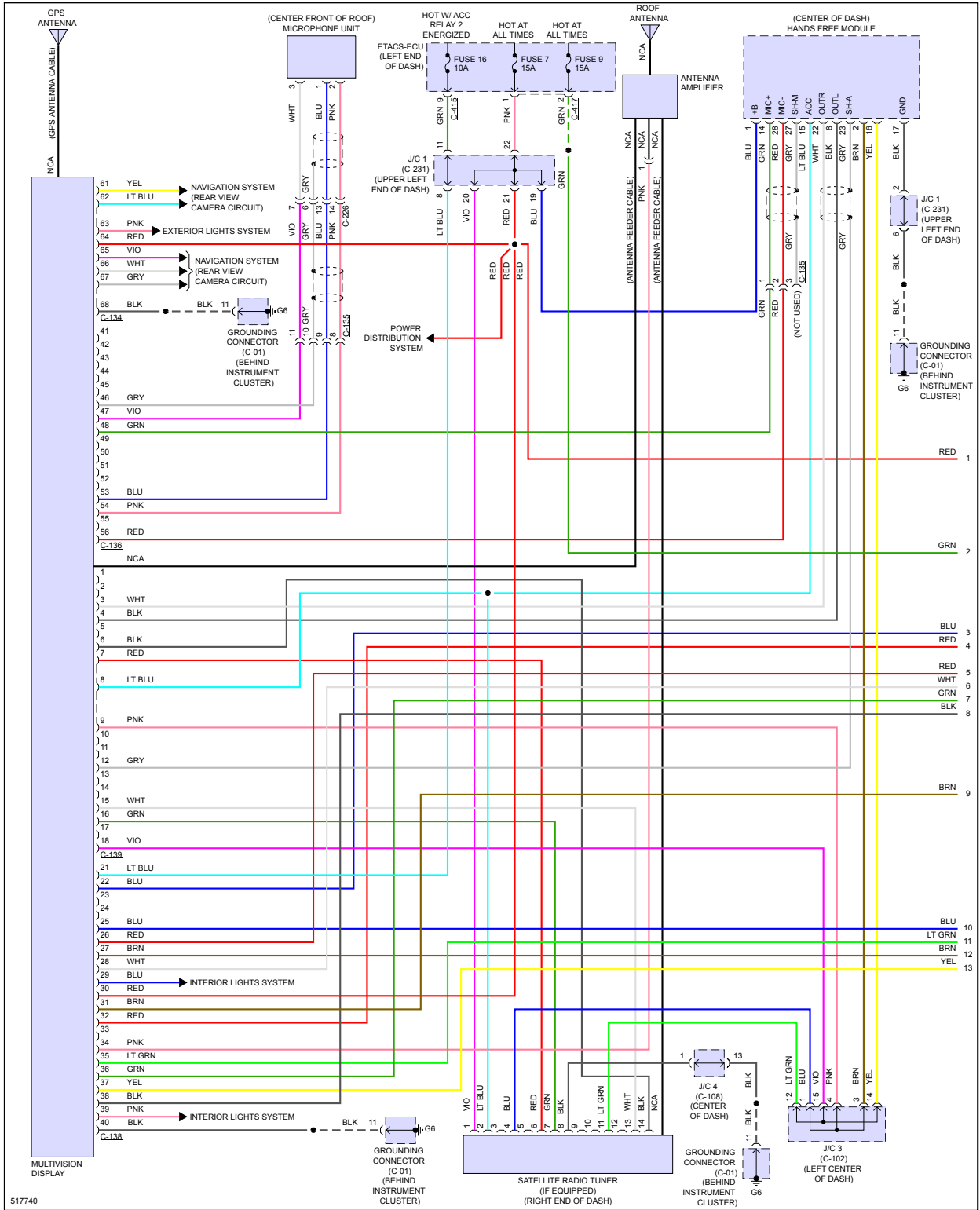

Fig 5: Radio Circuit, W/ Multi-Communication System W/O Amplifier (2 of 2)

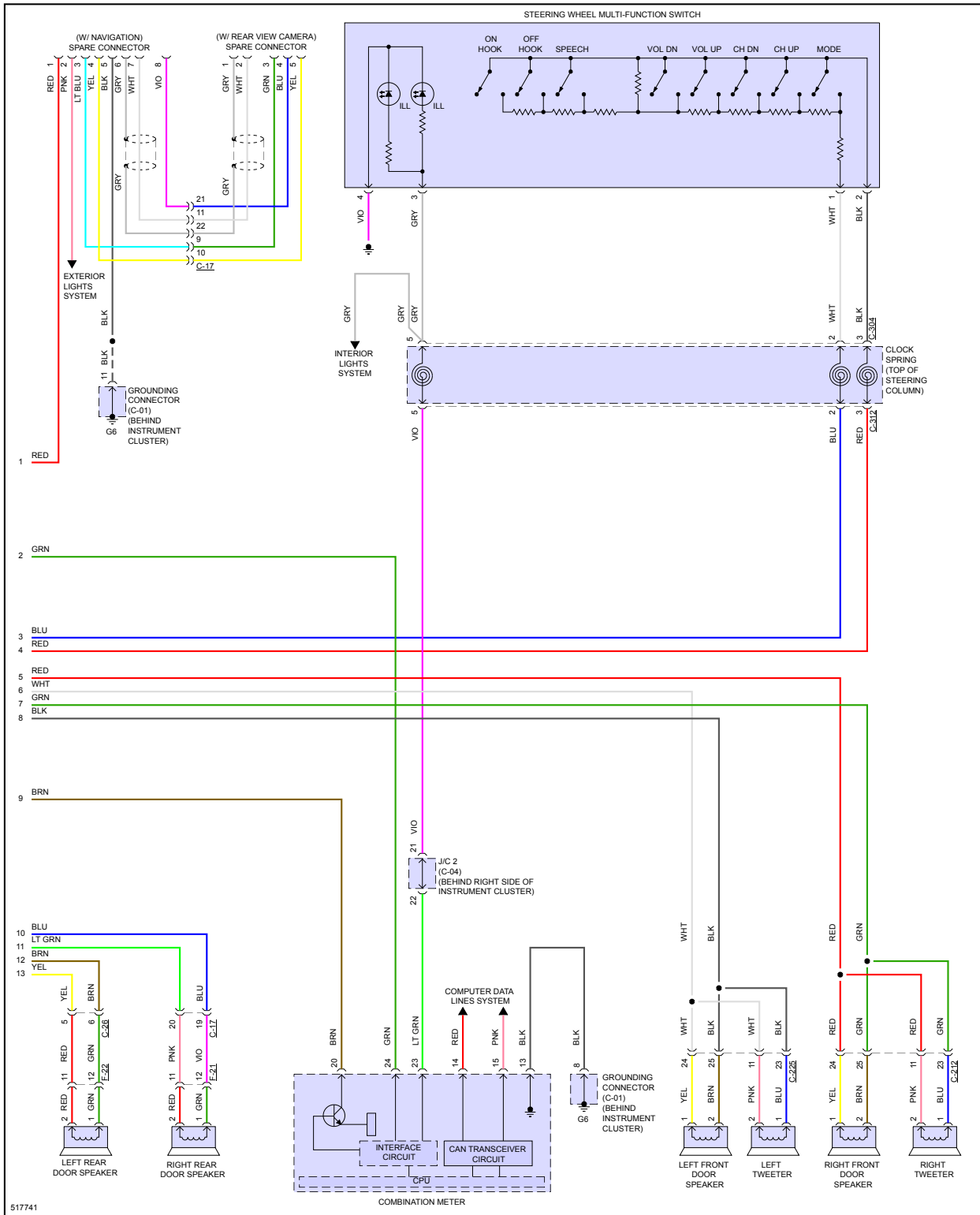

Fig 6: Radio Circuit, W/O Multi-Communication System W/ Amplifier (1 of 3)

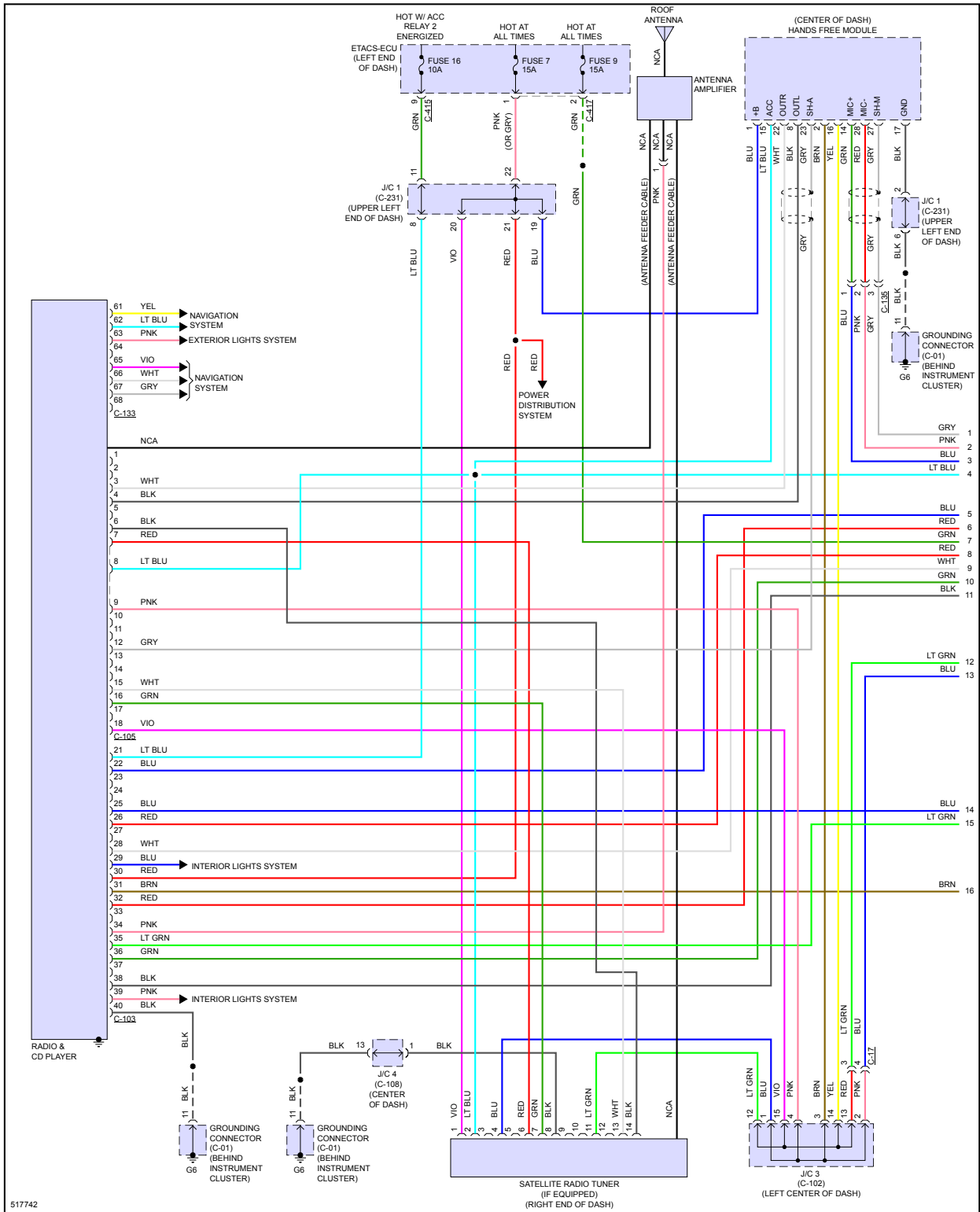

Fig 7: Radio Circuit, W/O Multi-Communication System W/ Amplifier (2 of 3)

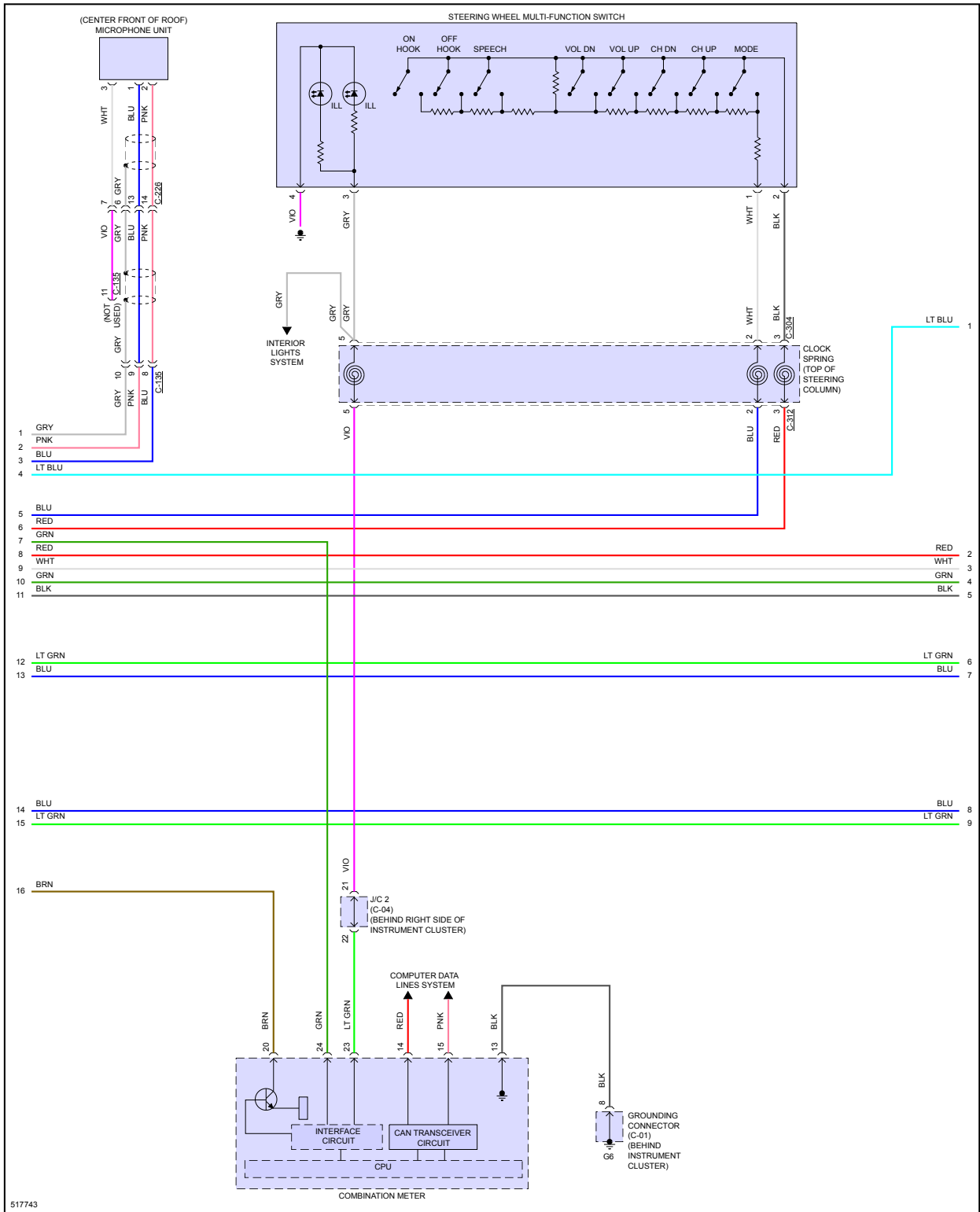

Fig 8: Radio Circuit, W/O Multi-Communication System W/ Amplifier (3 of 3)

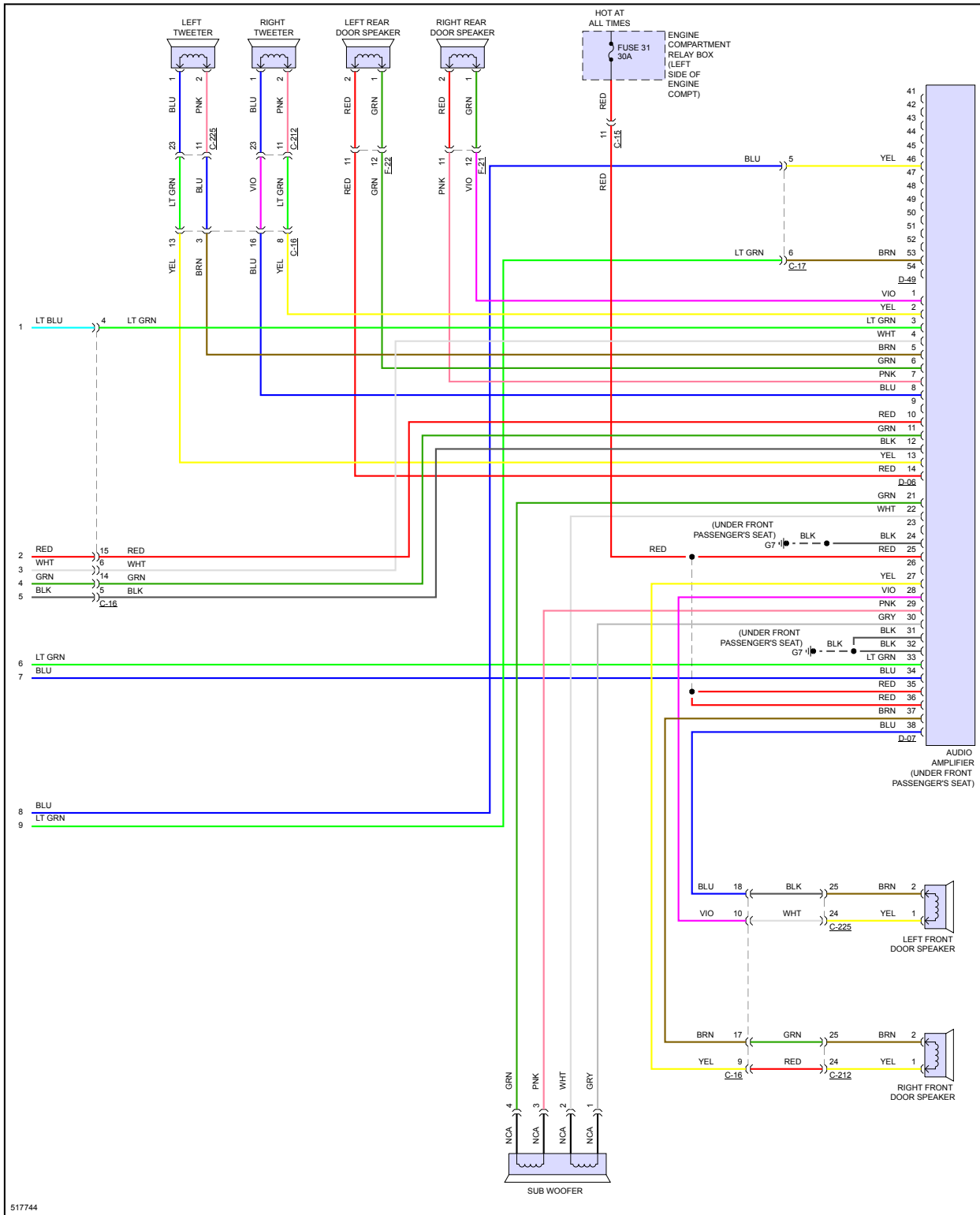

Fig 9: Radio Circuit, W/O Multi-Communication System W/O Amplifier (1 of 2)

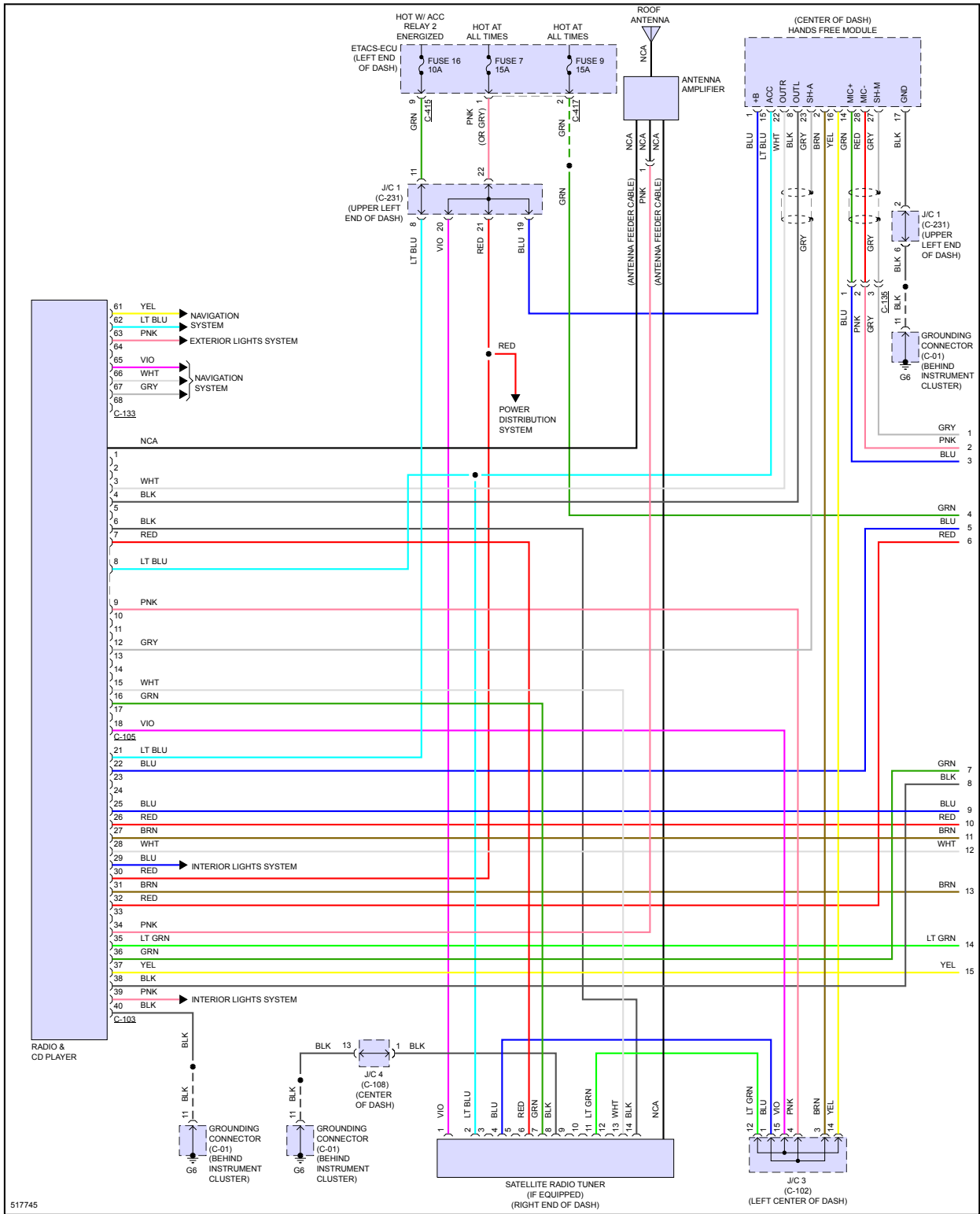
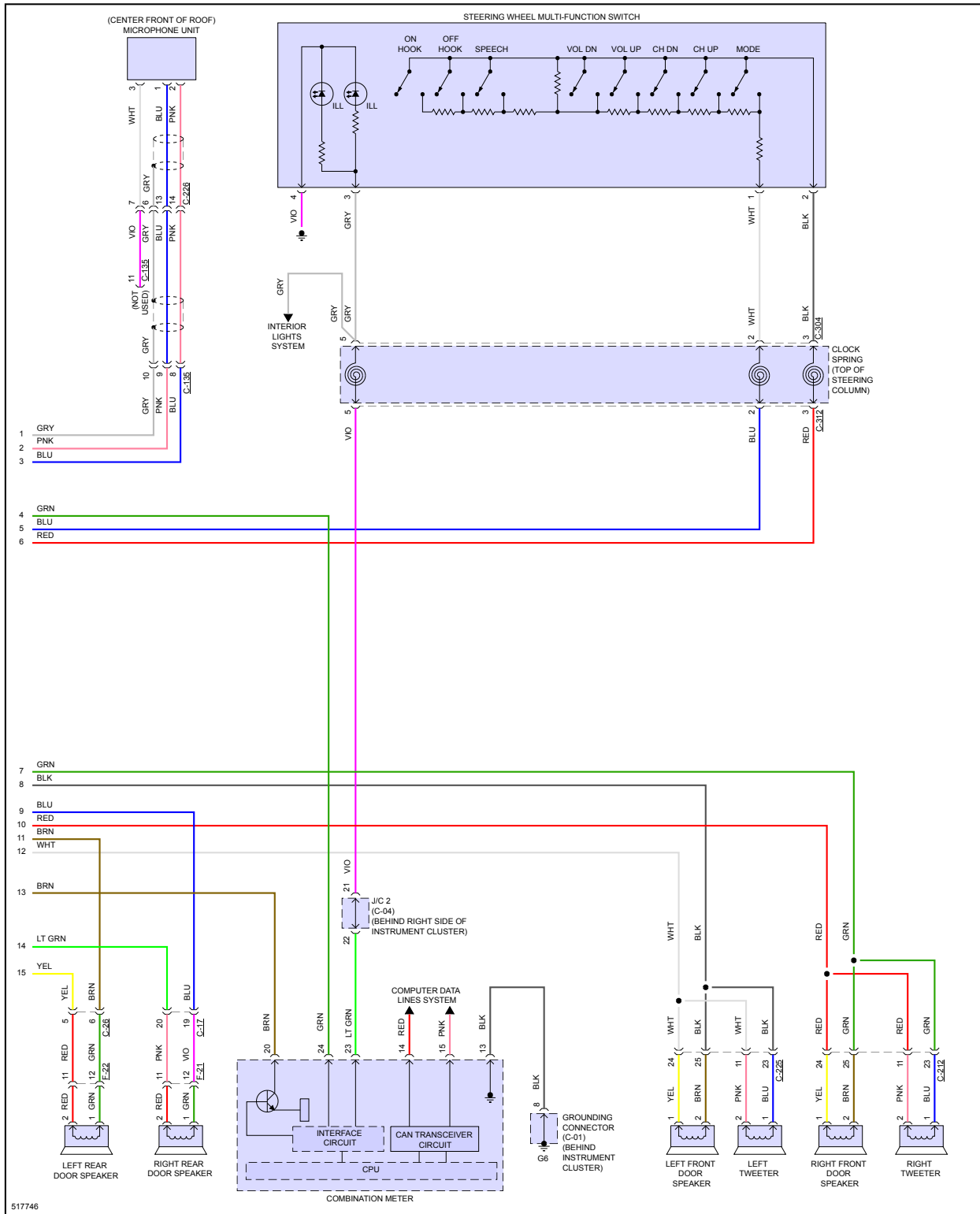
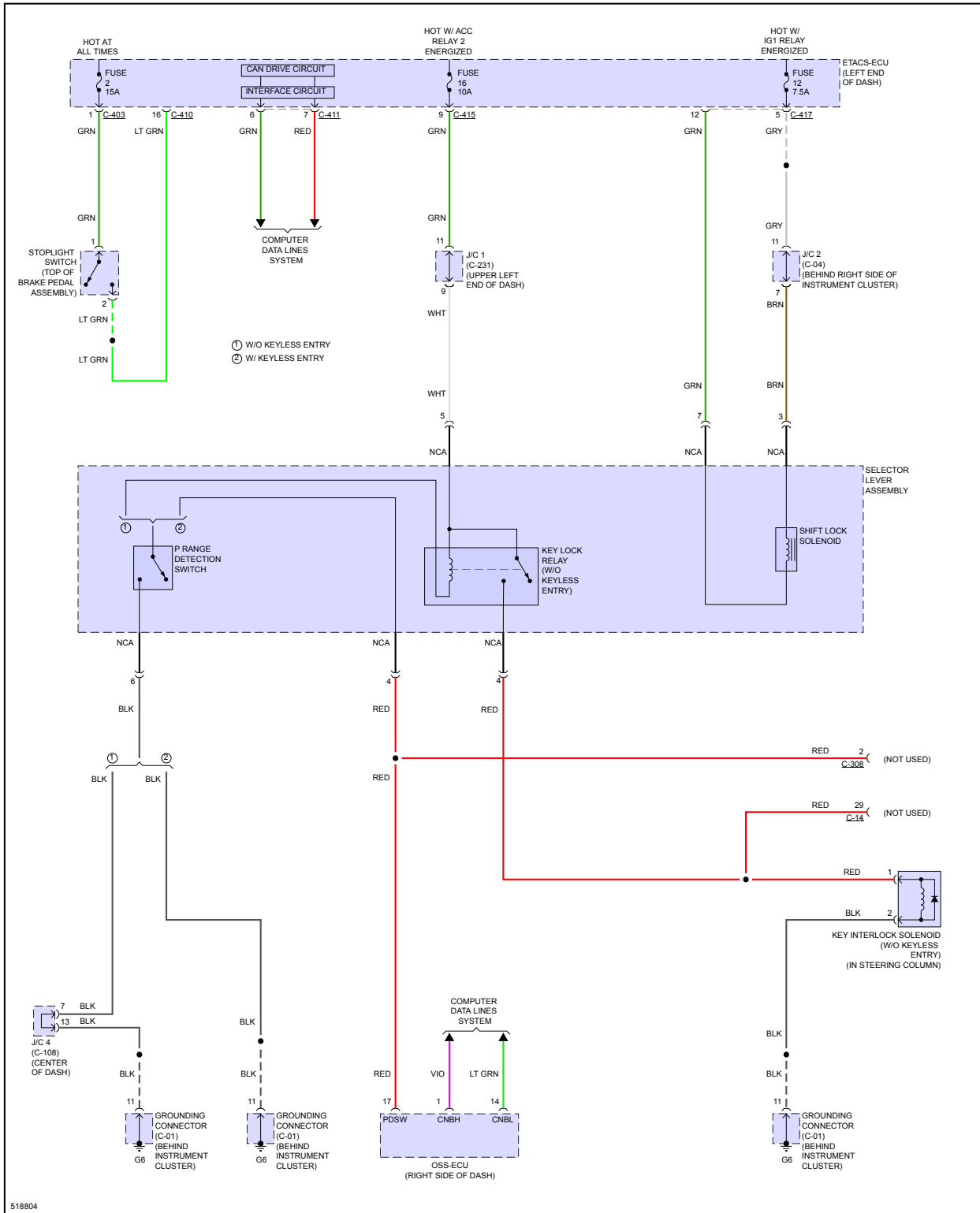

Fig 10: Radio Circuit, W/O Multi-Communication System W/O Amplifier (2 of 2)



SHIFT INTERLOCK

Fig 1: Shift Interlock Circuit



STARTING/CHARGING

Fig 1: Charging Circuit

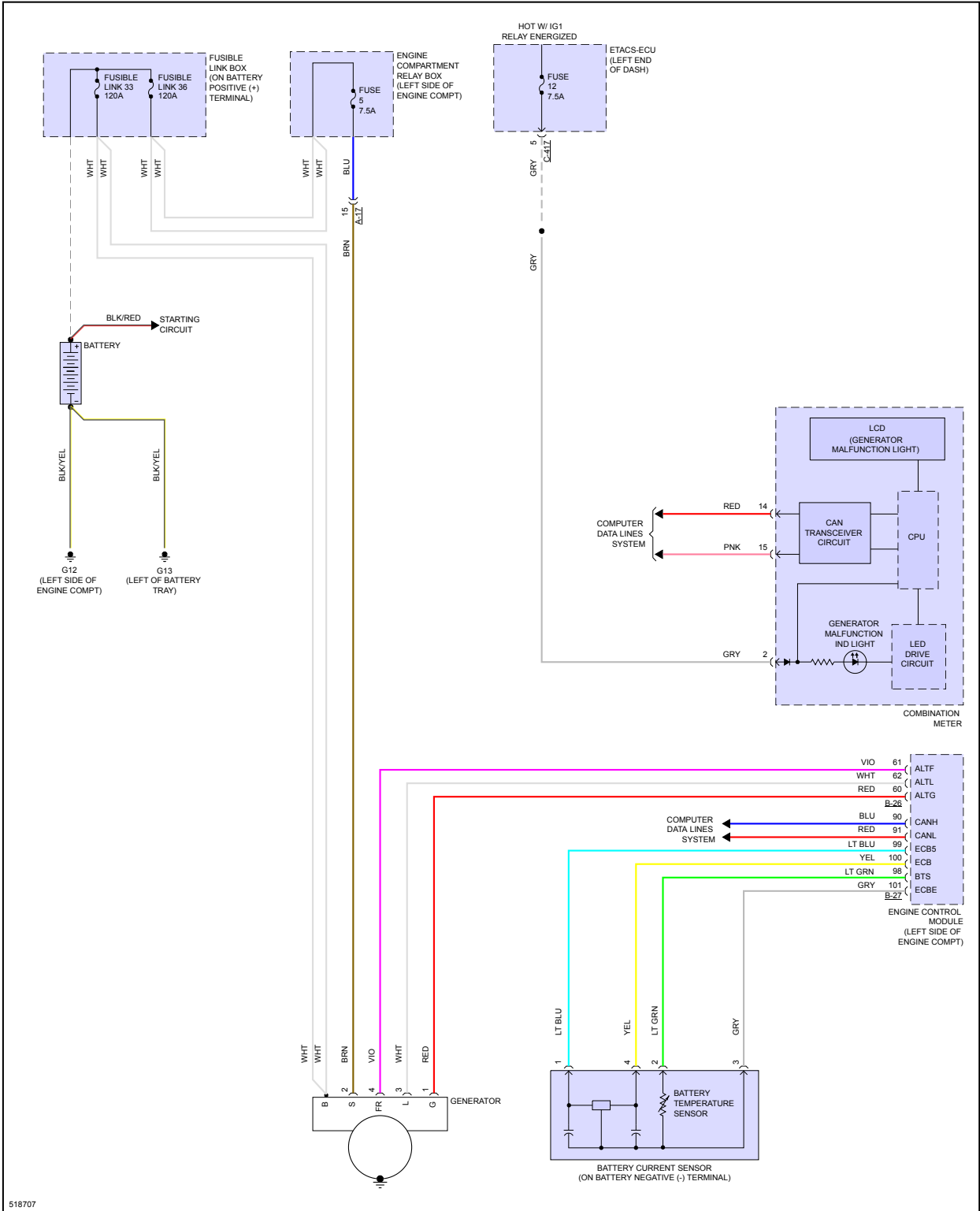
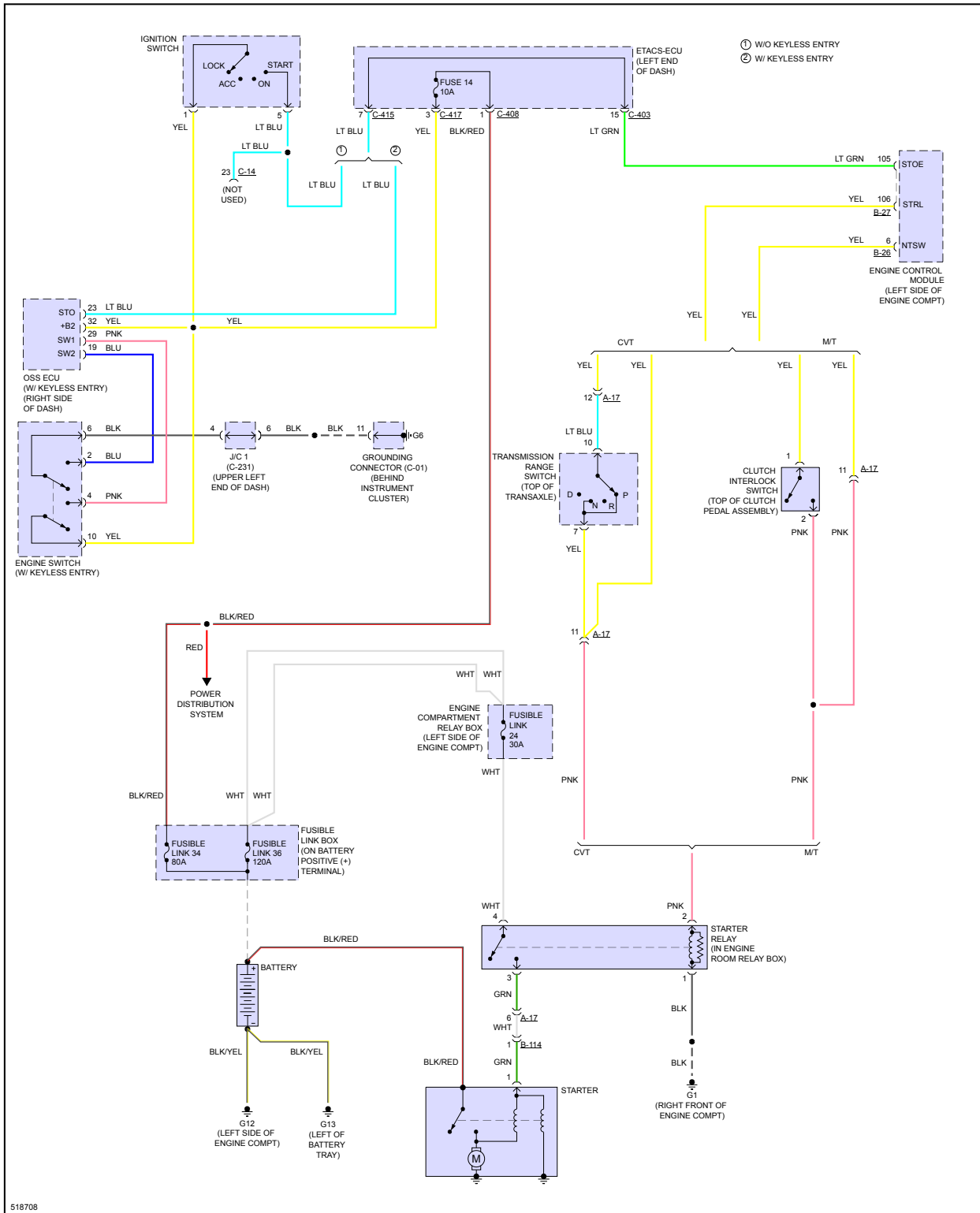

Fig 2: Starting Circuit



SUPPLEMENTAL RESTRAINTS

Fig 1: Supplemental Restraints Circuit (1 of 4)

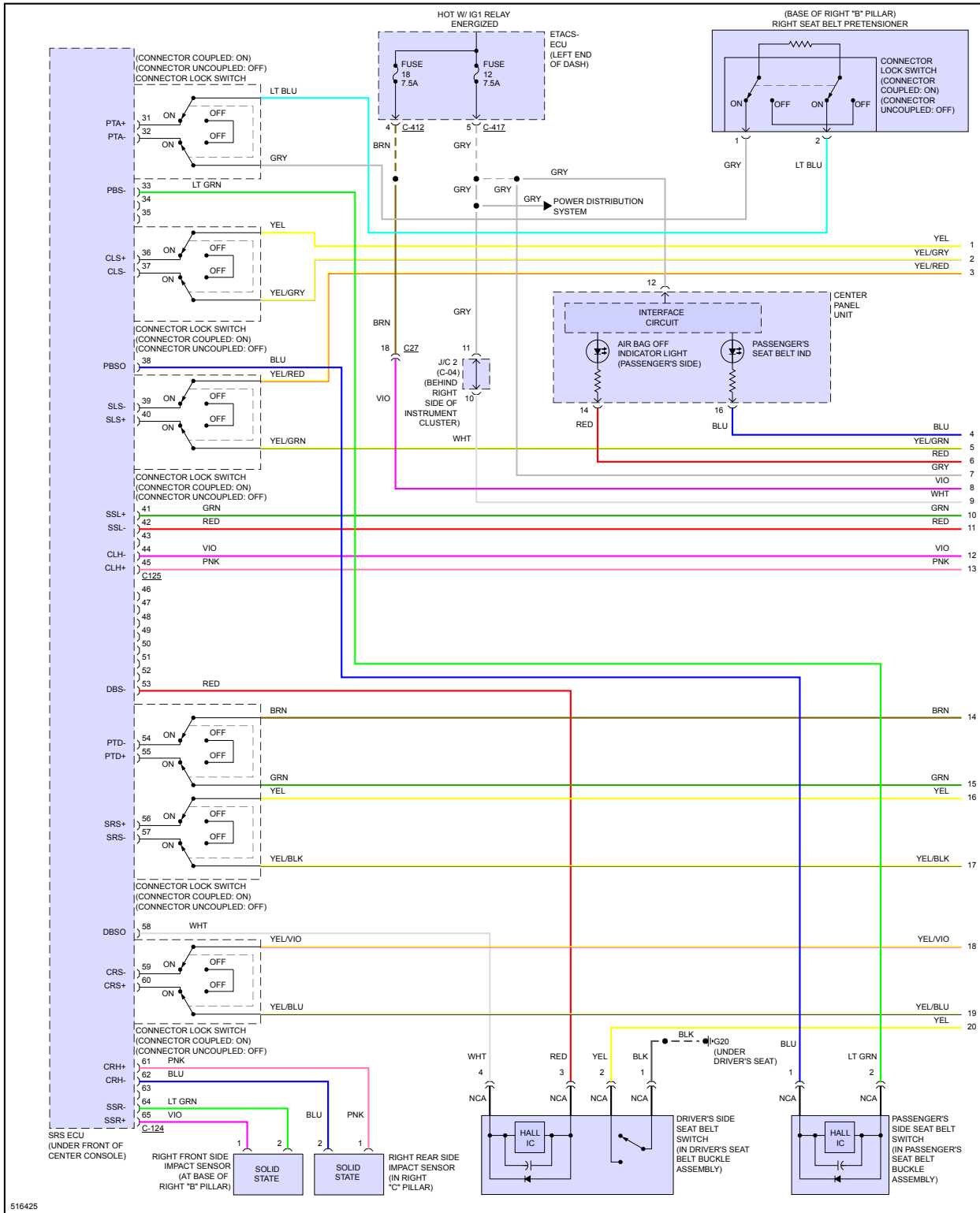

Fig 2: Supplemental Restraints Circuit (2 of 4)

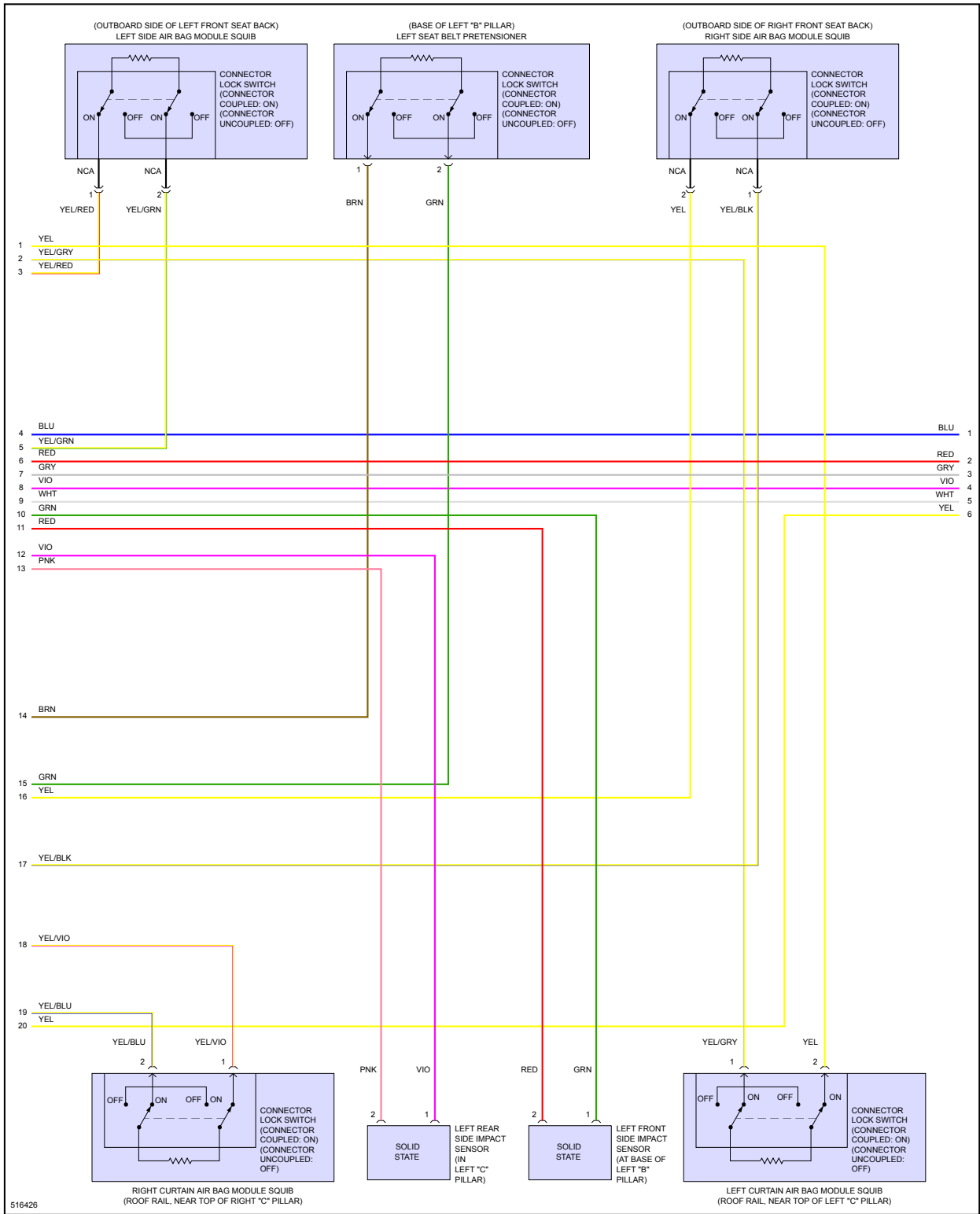

Fig 3: Supplemental Restraints Circuit (3 of 4)

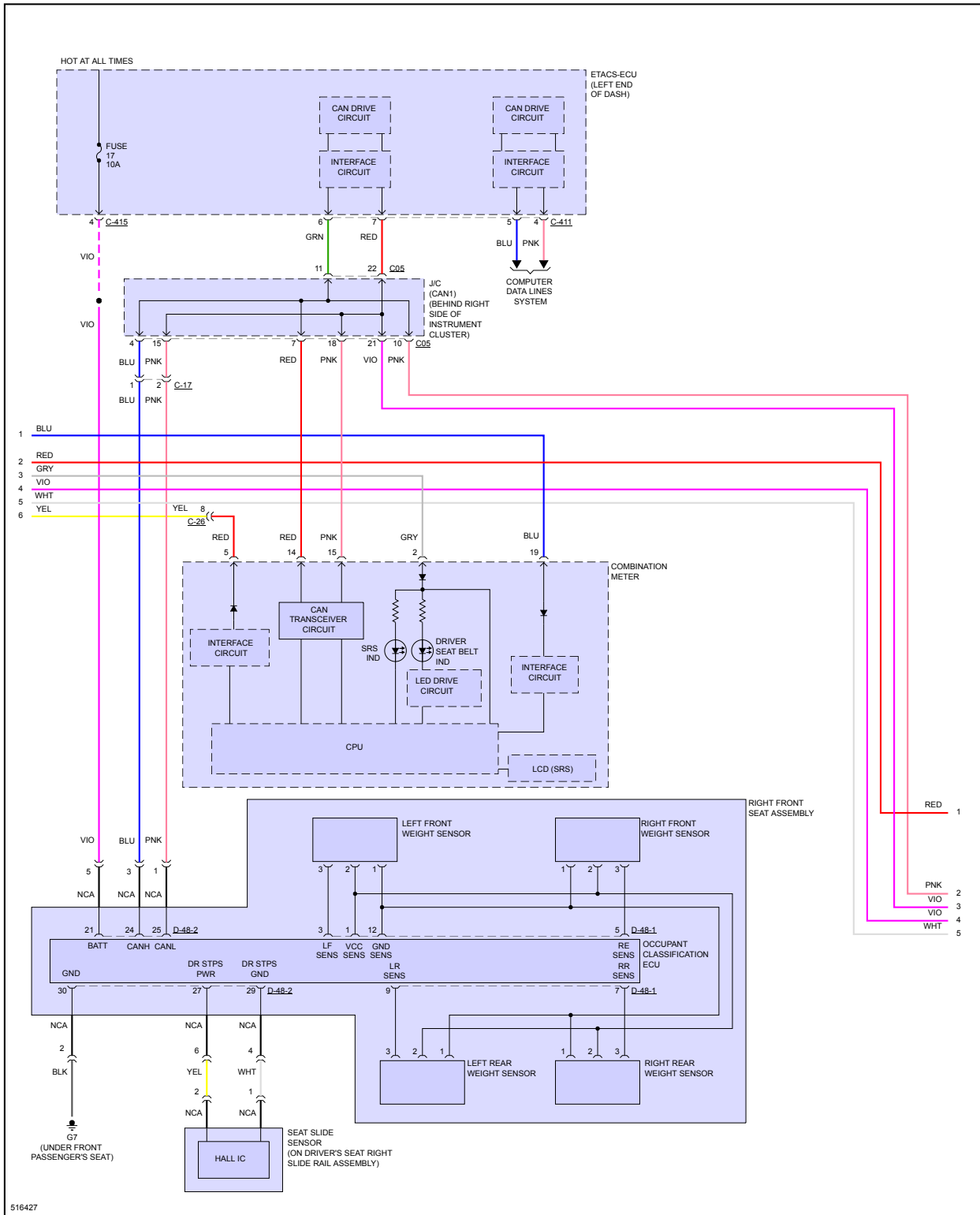
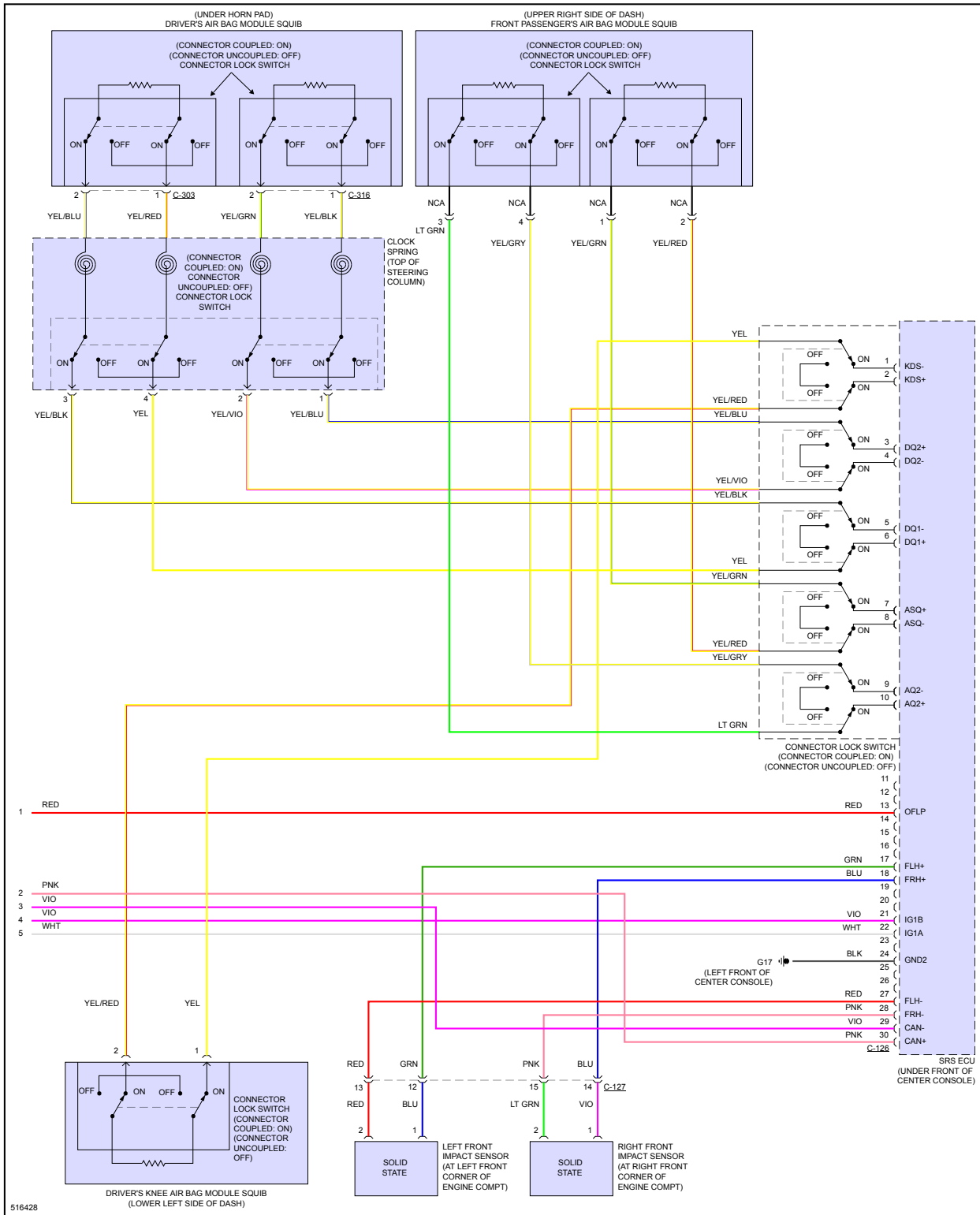

Fig 4: Supplemental Restraints Circuit (4 of 4)



TRANSMISSION > 2.0L

Fig 1: 2.0L, A/T Circuit (1 of 2)

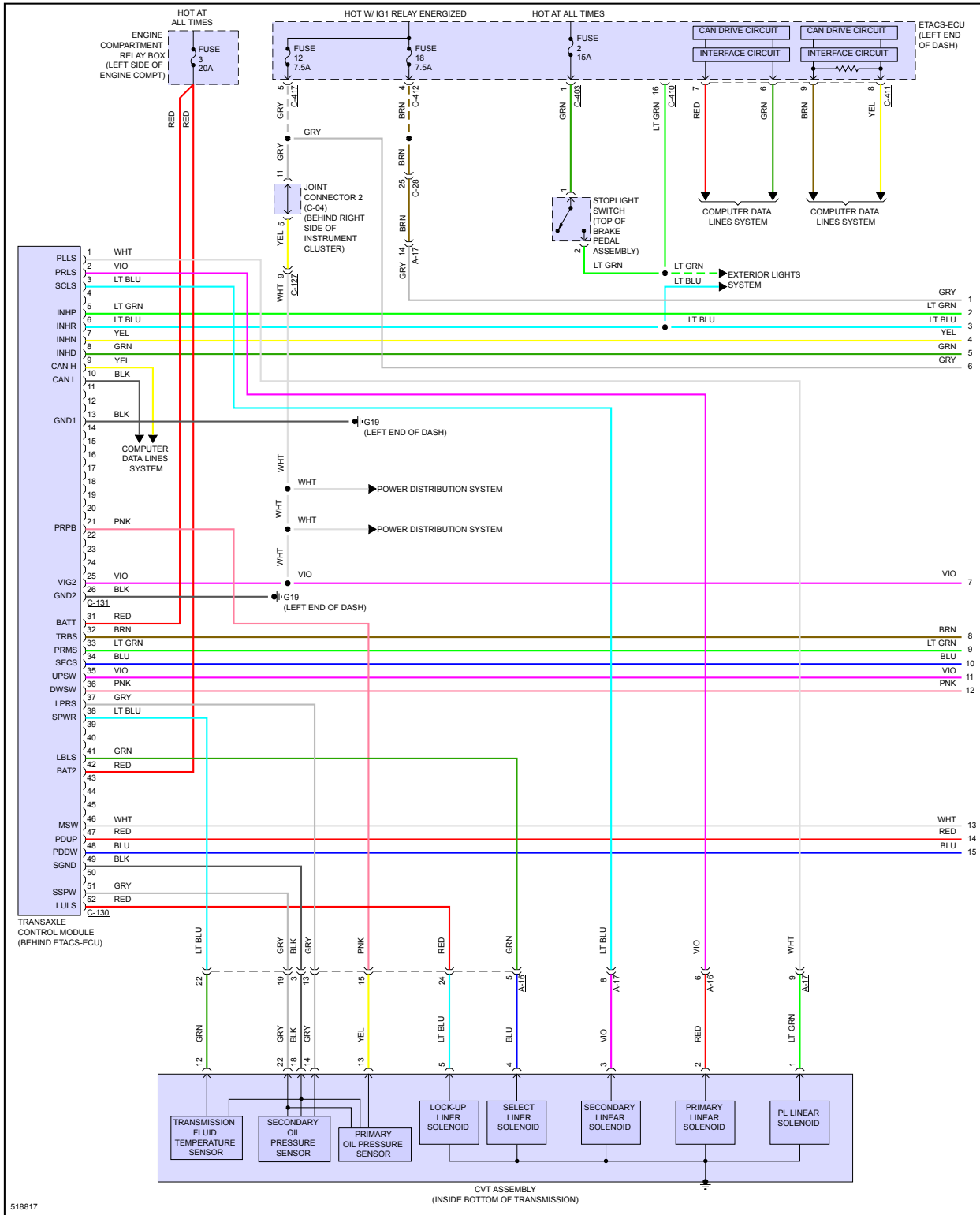

Fig 2: 2.0L, A/T Circuit (2 of 2)

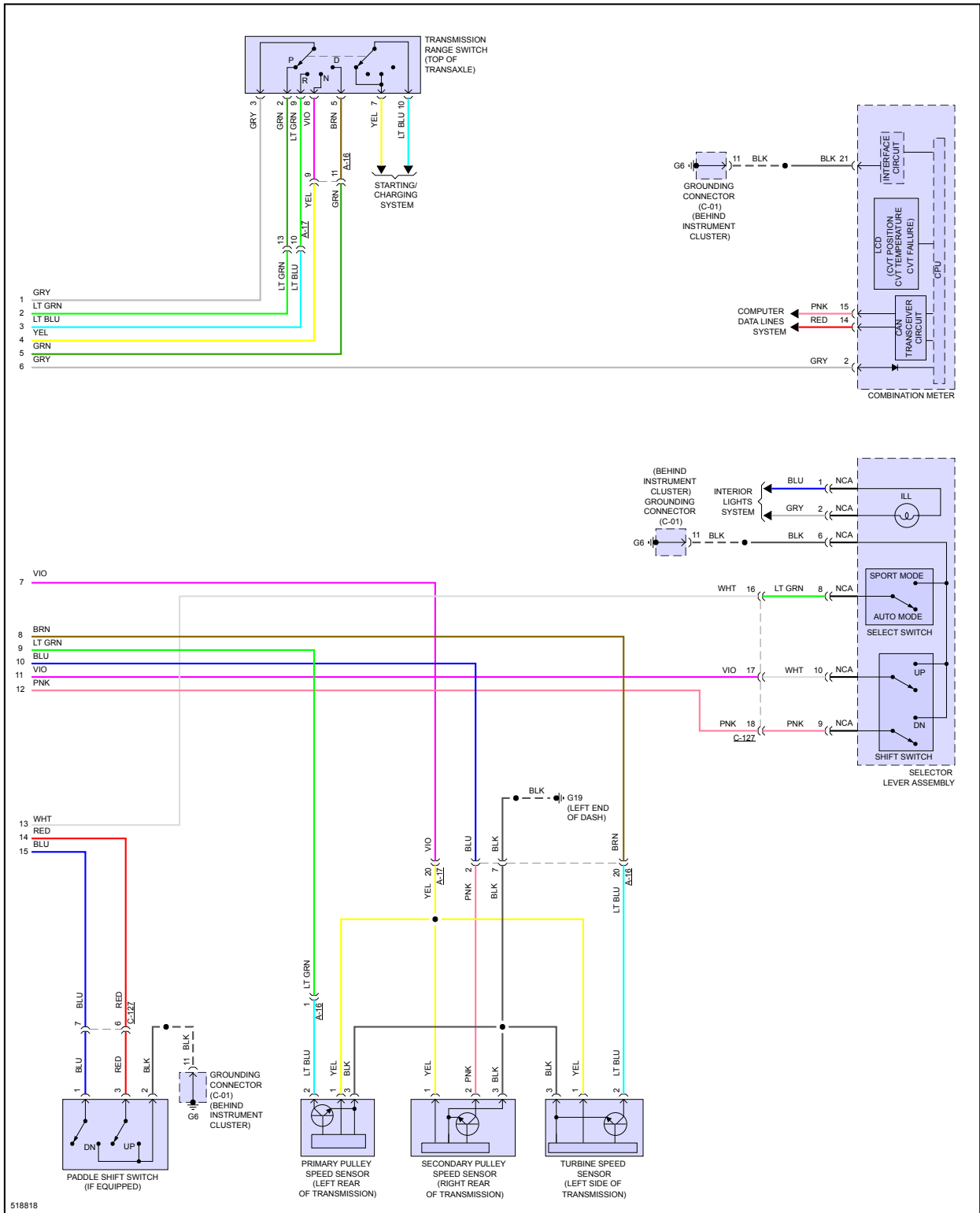
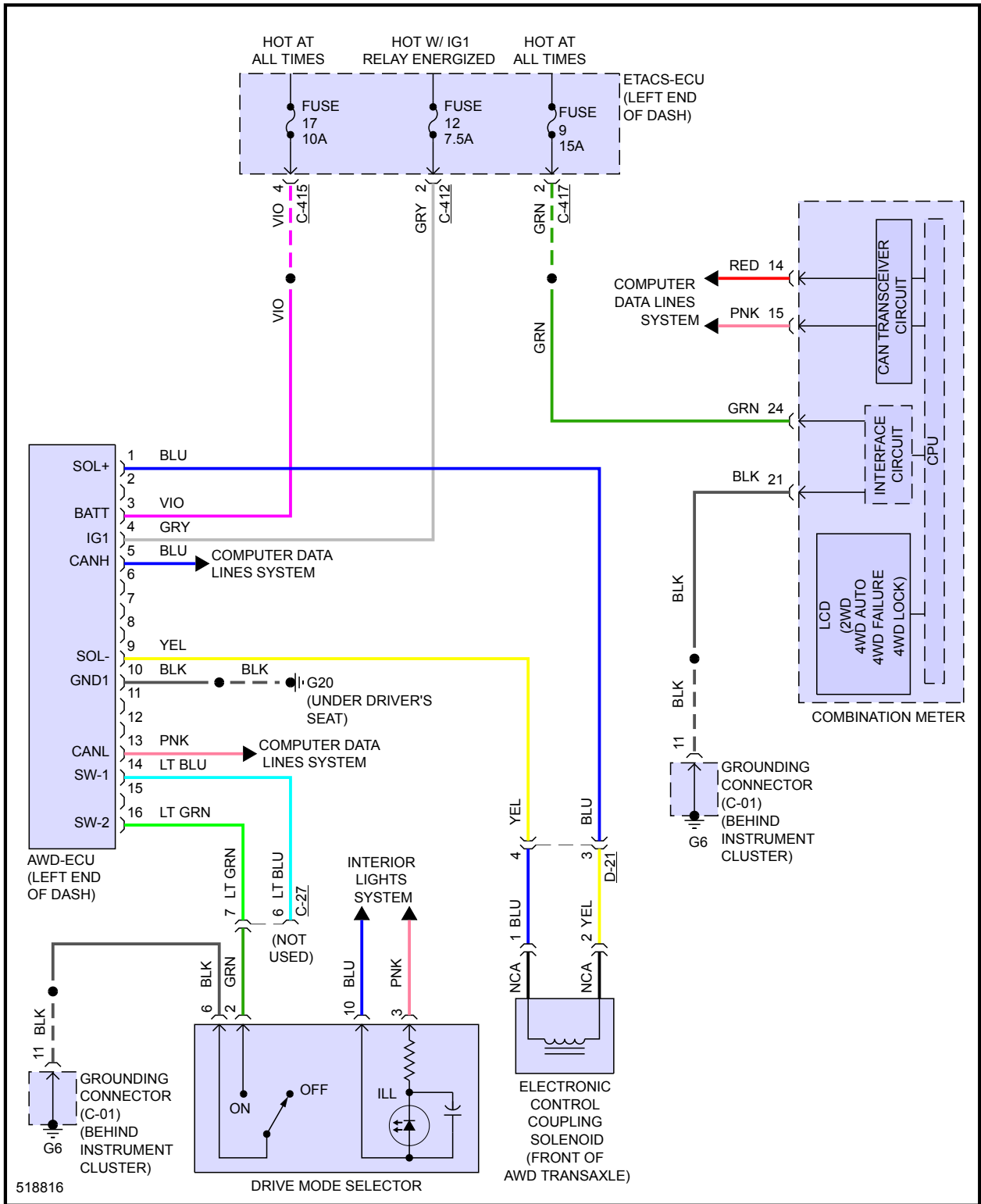

Fig 3: 2.0L, AWD Circuit



TRANSMISSION > 2.4L

Fig 1: 2.4L, A/T Circuit

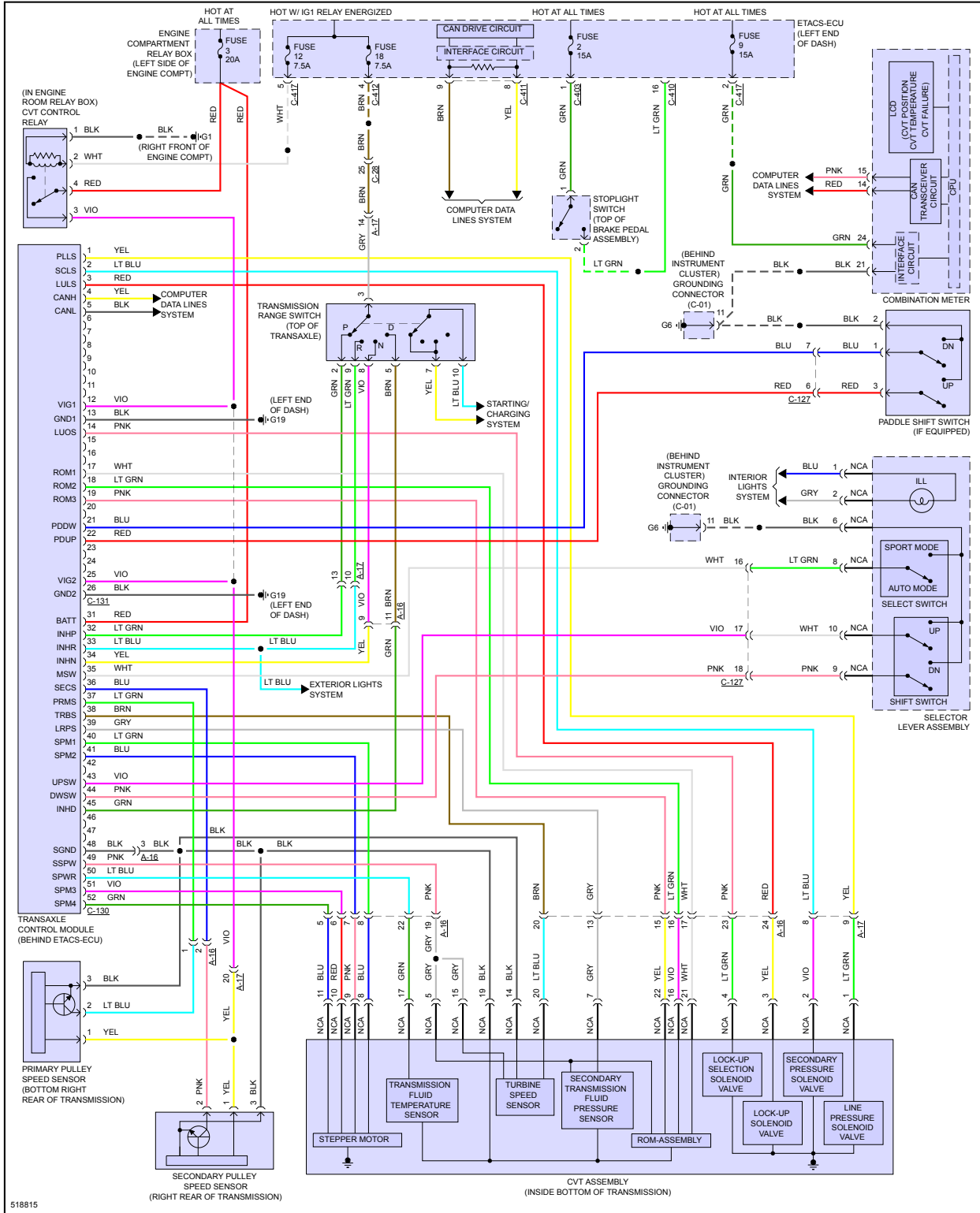
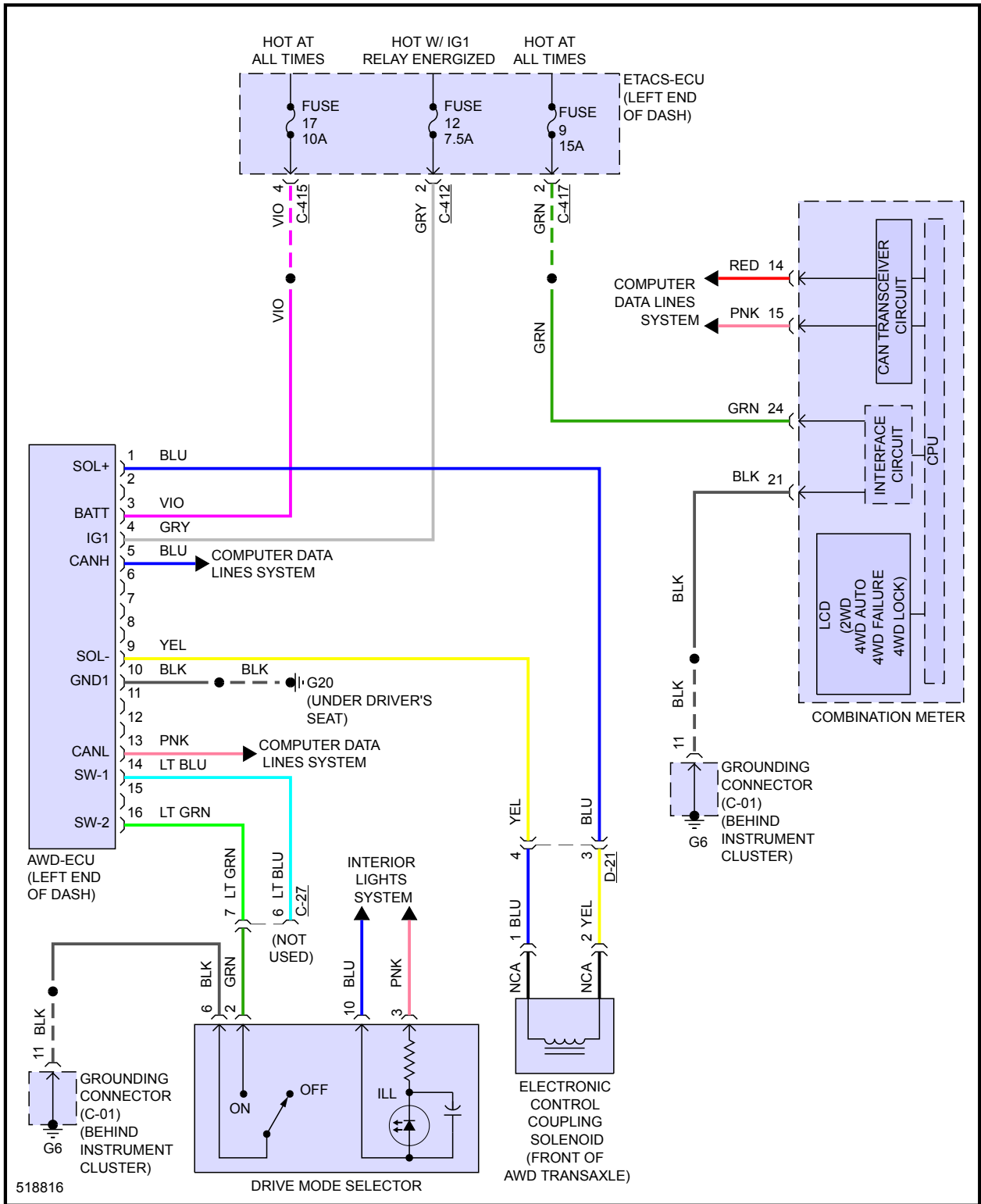
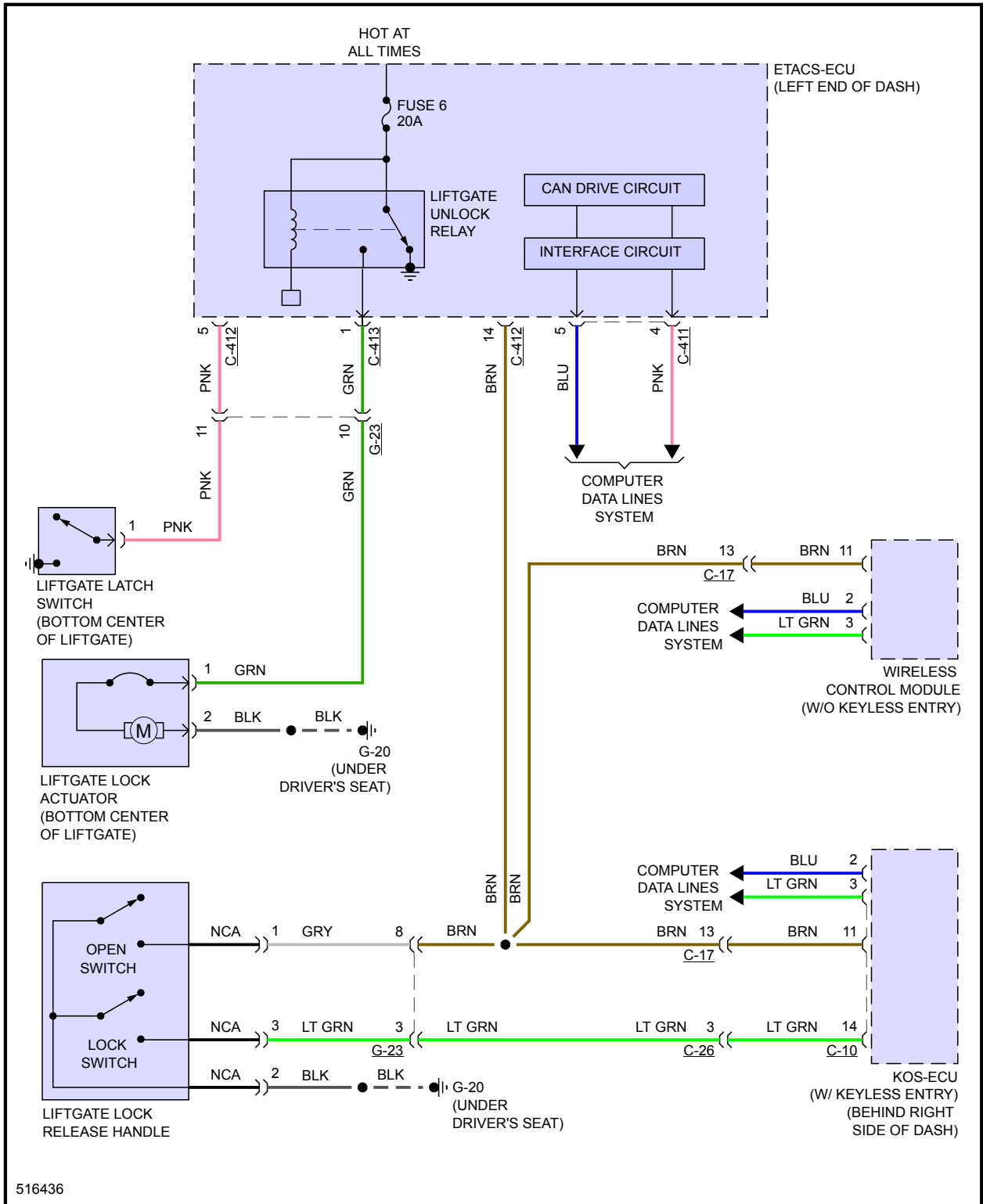

Fig 2: 2.4L, AWD Circuit



TRUNK, TAILGATE, FUEL DOOR

Fig 1: Trunk Release Circuit



WARNING SYSTEMS

Fig 1: Chime Circuit

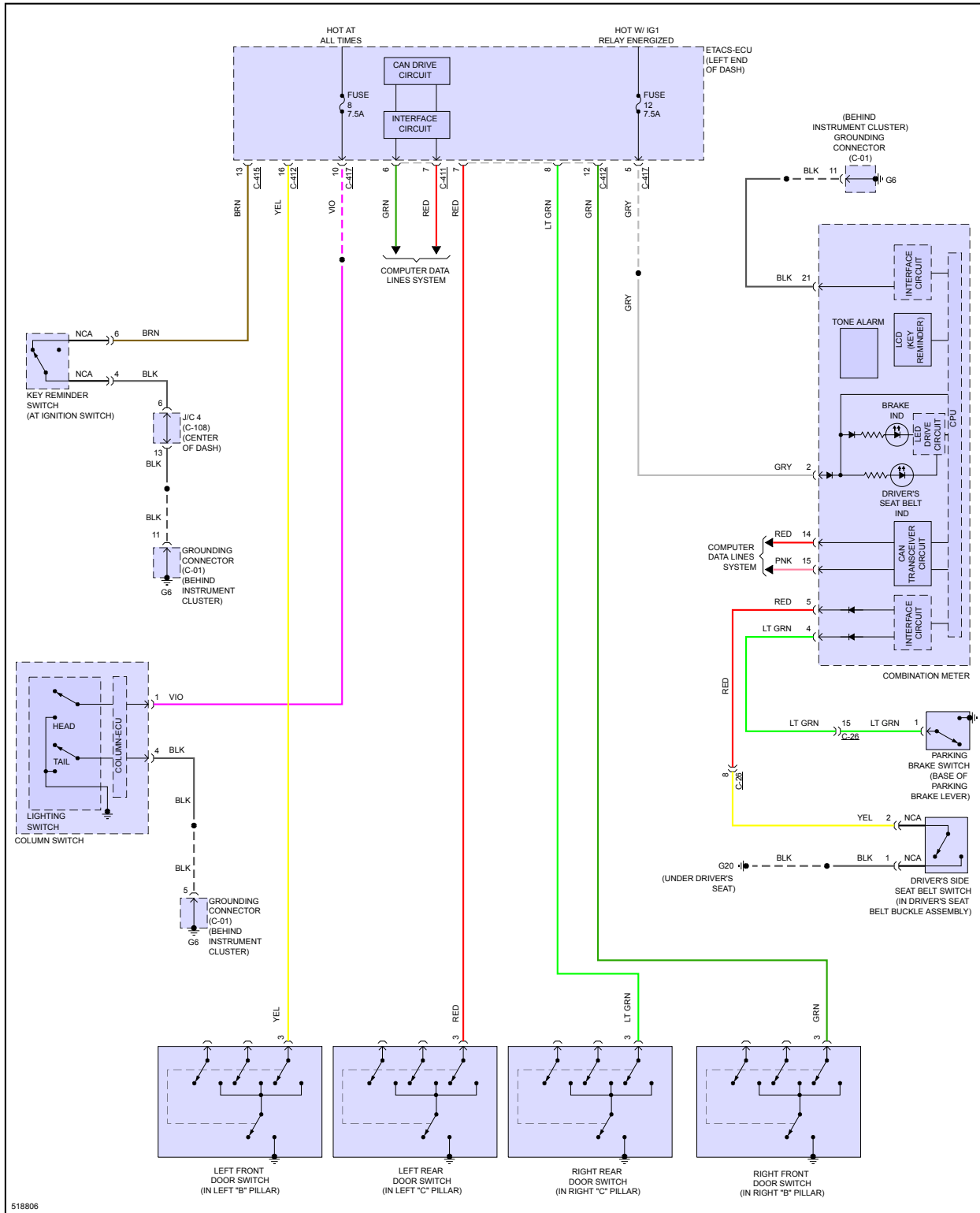
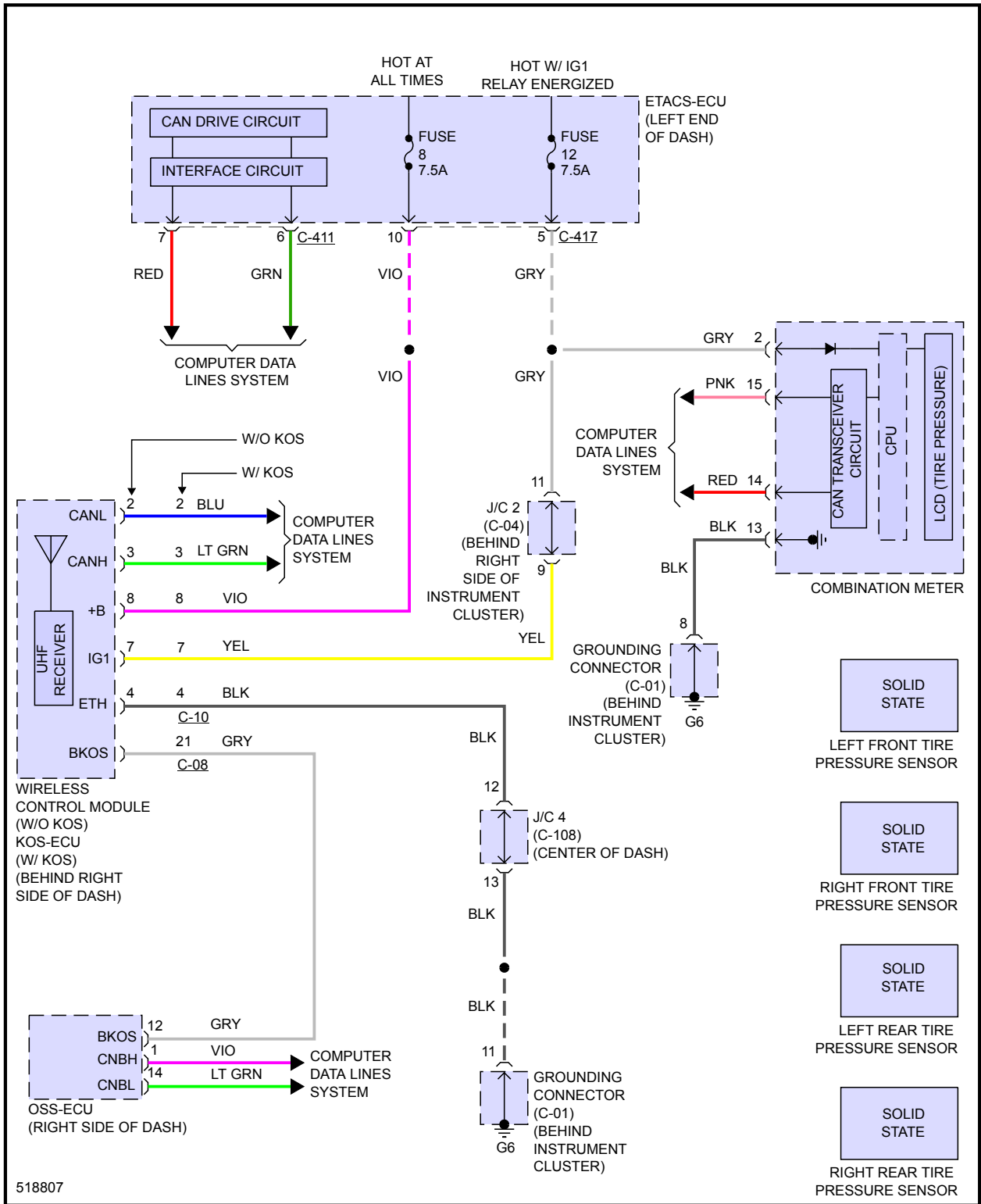

Fig 2: Tire Pressure Monitoring Circuit



WIPER/WASHER

Fig 1: Front Wiper/Washer Circuit

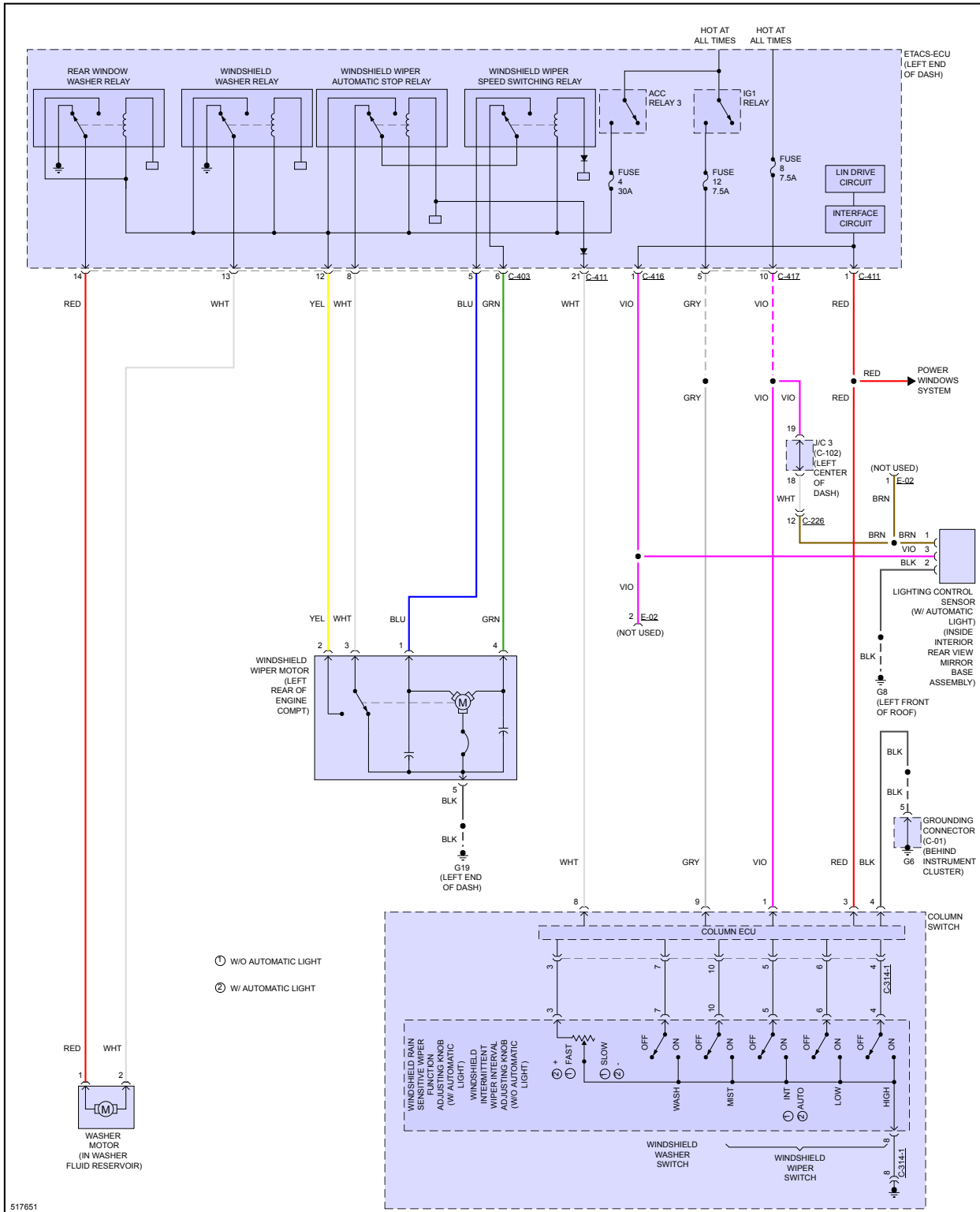

Fig 2: Rear Wiper/Washer Circuit

