

THIS MANUAL COVERS:

Mercedes-Benz Transporter
207D, 307D, 210D, 410D,
208D, 308D, 310D, 408D
601, 602 and 616 Engines

DETAILED DESCRIPTION OF REMOVAL,
INSTALLATION, ADJUSTMENTS, REPAIRS,
OVERHAUL AND SERVICING OF ALL THE MAJOR
VEHICLE PARTS (except body), INCL. ENGINE,
VALVES, DIESEL FUEL INJECTION SYSTEM,
CLUTCH, BRAKES, STEERING, TRANSMISSION
(except overhaul), FRONT AND REAR AXLES AND
SUSPENSION, ENGINE ELECTRICS - WITH
EXPLODED VIEWS AND COMPLETE TECHNICAL
DATA AND WIRING DIAGRAMS.

www.russek-manuals.co.uk

ANOTHER BOOK
PUBLISHED BY:

**PETER RUSSEK
PUBLICATIONS LTD.**

Telephone:
01494 440829

PETER RUSSEK Mercedes-Benz 208D and Variants POCKET MECHANIC

POCKET MECHANIC

**VEHICLE
MANUAL**

Mercedes-Benz
207D, 307D, 210D, 410D
208D, 308D, 310D, 408D



**2.3, 2.4 AND 2.9 LITRE
DIESEL ENGINES**

ADJUSTMENTS • TUNE-UP
REPAIRS • OVERHAULS
SERVICING • FAULT FINDING

**PETER
RUSSEK**
MANUALS

POCKET MECHANIC

Mercedes-Benz

**207D, 307D, 210D, 310D,
410D, 208D, 308D, 408D
2.3, 2.4 and 2.9 Litre Diesel**

COVERING:

GENERAL INFORMATION, DIMENSIONS, WEIGHTS, CAPACITIES, GENERAL, SERVICING NOTES	4
ENGINES	9
LUBRICATION SYSTEM	65
COOLING SYSTEM	69
DIESEL FUEL INJECTION SYSTEM	77
CLUTCH	89
MANUAL TRANSMISSION	94
FRONT AXLE	100
REAR AXLE AND PROPELLER SHAFT	110
FRONT AND REAR SUSPENSION	118
STEERING	120
BRAKE SYSTEM	127
ELECTRICAL SYSTEM	145
2.4 LITRE DIESEL ENGINE – TYPE 616	153
SERVICING AND MAINTENANCE	176
FAULT FINDING SECTION	179
WIRING DIAGRAMS	188

BY PETER RUSSEK

ORDER NO.: 445

Published by
Peter Russek Publications Ltd.
3rd Floor, Block C
Commercial Square
High Wycombe, Bucks, HP11 2RH
Tel.: High Wycombe (01494) 440829
(01494) 528882
Fax: (01494) 473980
E-mail: russek@globalnet.co.uk
www.russek-manuals.co.uk

ISBN NO. 1-898780-45-5

WITH FAULT FINDING SECTION
AT END OF MANUAL

The publisher would like to thank Daimler Chrysler U.K. Ltd. for their invaluable support in producing this manual.

No part of this publication may be reproduced, stored in a retrieval system or transmitted in any form, electronic, mechanical, photocopying, recording, translating or other means without prior permission by the author.

No liability can be accepted for any inaccuracies or Omissions in this workshop manual, although every possible care has been taken to make it as complete and accurate as possible. Every care has also been taken to prevent personal injury or damage to equipment when working on the vehicle. We have tried to cover all models produced to the day of publication, but are unable to refer to all modifications and changes for certain markets or updating of models.

Re-published and re-printed January 2006

© Peter R.D.Russek - 2000 Printed in England

PREFACE

Small though this Workshop Manual is in size, it lacks no detail in covering most of the servicing and repair of the Mercedes Van and Camper Diesel models listed on the outside cover with 2.3 and 2.9 litre engine (engine types 601 and 602) and the earlier 2.4 litre engine (engine type 616).

Brief, easy-to-follow instructions are given, free from all necessary complications and repetitions, yet containing all the required technical detail and information, and many diagrams and illustrations.

Compiled and illustrated by experts, this manual provides a concise source of helpful information, all of which has been cross-checked for accuracy to the manufacturer's official service and repair procedures, but many instructions have derived from actual practice to facilitate your work. Where special tools are required, these are identified in the text if absolutely necessary and we do not hesitate to advise you if we feel that the operation cannot be properly undertaken without the use of such tools.

The readers own judgement must ultimately decide just what work he will feel able to undertake, but there is no doubt, that with this manual to assist him, there will be many more occasions where the delay, inconvenience and the cost of having the van off the road can be avoided or minimised.

The manual is called "Pocket Mechanic" and is produced in a handy glove pocket size with the aim that it should be kept in the vehicle whilst you are travelling. Many garage mechanics themselves use these publications in their work and if you have the manual with you in the vehicle you will have an invaluable source of reference which will quickly repay its modest initial cost.

A general faultfinding (troubleshooting) section is included at the end of the manual and all items listed are taken from actual experience, together with the necessary remedies to correct faults and malfunctioning of certain parts.

Important Note: The main text of the engine Section and some other sections associated with the engine, covers the 601 and 602 engine, although technical data are also given for the 616 engine. Differences for the 616 engine are described at the end of the manual in a separate section.

0. INTRODUCTION

Our "Pocket Mechanics" are based on easy-to-follow step-by-step instructions and advice, which enables you to carry out many jobs yourself. Moreover, now you have the means to avoid these frustrating delays and inconveniences which so often result from not knowing the right approach to carry out repairs which are often of a comparatively simple nature.

Whilst special tools are required to carry out certain operations, we show you in this manual the essential design and construction of such equipment, whenever possible, to enable you in many cases to improvise or use alternative tools. Experience shows that it is advantageous to use only genuine parts since these give you the assurance of a first class job. You will find that many parts are identical in the range covered in this manual, but our advice is to find out before purchasing new parts - **Always buy your spare parts from an officially appointed dealer.**

0.0. General Information

The manual covers the listed Mercedes-Benz commercial vehicles with 2.3 and 2.9 litre engines, but also refers to models with the earlier four-cylinder engine with 2.4 litre capacity. Models 208D, 308D and 408D are fitted with a 2.3 litre four-cylinder diesel engine with a performance of 58 kW (78 HP) at 3600 rpm (engine type 601). The remaining models are fitted with the 2.9 litre five-cylinder engine with a performance of 70 kW (95 HP) at 3800 rpm (engine type 602). The engine is similar to the four-cylinder engine, with the additional cylinder added on. Models 207D and 307D are fitted with the 2.4 litre engine, engine type 616.

Details of the 616 engine are covered under separate headings, whenever differences are such that a new Section is necessary.

Many different body versions and model numbers are used in the range of vehicles marketed. The following table shows some of the models together with their type designation and fitted engine to the later model range. These numbers are sometimes referred to, mainly in the technical data sections and you should familiarise yourself with the model number of your vehicle. We should like to stress that not all vehicles are sold in any particular country.

All vehicles covered in the manual are fitted with a four-speed or five-speed transmission.

Model	Model Number	Fitted engine
MB 208D	601.3	601.940
MB 308D	602.3	601.940
MB 408D	611.3	601.940
MB 210D	601.4	602.940
MB 310D	602.4	602.940
MB 410D	611.4	602.940

0.1. Identification

When you purchase the vehicle you will have received various data cards which have all important vehicle details, as for example chassis number and component numbers as well as identification of optional equipment, etc. Your Owner's Manual will give you further instructions on the use of these cards. Owner's Manuals were obtainable under No. 601 584 36 96, but you will have to check if this number is still valid, as it is possible that they are no longer available.



Fig. 0.1 - The position of the vehicle identification number (1) and the type identification plate (2).

The type identification plate with the vehicle identification number can be found on the door entry at the position shown in Fig. 0.1. Immediately next to it you will find an additional plate, giving again the vehicle identification number, the max. permissible vehicle weight and the basic setting of the headlamps. Details of the body/number and the paint work are given in a plate, fitted to the L.H. door pillar, as shown in Fig. 0.2.

Fig. 0.2 - With the door open you will see a type plate (1) with details of the body and paint identification codes.

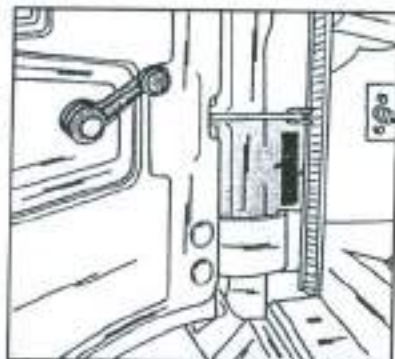

The engine number can be found near the injection pipes at the position shown in Fig. 0.3, on the L.H. side of the cylinder block. Transmission, rear axle and steering also have a serial number, stamped into the housing.

Always quote the complete chassis number and/or engine number and the model year, when ordering parts. Important is also the actual model number, which will indicate the construction of the vehicle, for example two or four wheels on the rear axle, etc.

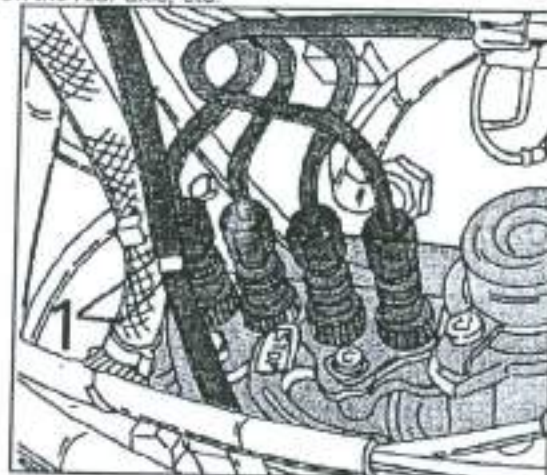

Fig. 0.3 - The engine number can be found at (1).

0.2 Filling Capacities

Fuel tank	70 litres (12 litres reserve)
- Optional	2 x 65 litres (13 litres reserve)
Engine:	
- 601, four-cylinder, complete re-fill	7.3 litres
- 601, oil change with filter	6.5 litres
- 602, five-cylinder, complete re-fill	7.5 litres
- 602, oil change with filter	7.0 litres
- 616, four-cylinder, complete re-fill	7.5 litres
- 616, oil change with filter	6.5 litres
Min. Oil Fill Capacity:	
- 601 engine	5.0 litres
- 602 engine	5.5 litres
- 616 engine	3.5 litres
Cooling System:	
- 601 engine	7.0 litres
- 602 engine	7.5 litres
- 616 engine	11.7 litres
Transmission:	
Automatic transmission (fluid change)	2.3 litres
Power assisted steering	5.9 litres
Rear axle:	1.6 litres
- Axle type 741.400 and 741.401	1.8 litres
- Axle type 741.404 and 741.405	1.8 litres
- Axle type 741.5 (twin wheels)	1.8 litres

0.3. General Servicing Notes

The servicing and overhaul instructions in this Workshop Manual are laid out in an easy-to-follow step-by-step fashion and no difficulty should be encountered, if the text and diagrams are followed carefully and methodically. The "Technical Data" sections form an important part of the repair procedures and should always be referred to during work on the vehicle.

In order that we can include as much data as possible, you will find that we do not generally repeat in the text the values already given under the technical data headings. Again, to make the best use of the space available, we do not repeat at each operation the more obvious steps necessary - we feel it to be far more helpful to concentrate on the difficult or awkward procedures in greater detail. However, we summarise below a few of the more important procedures and draw your attention to various points of general interest that apply to all operations.

Always use the torque settings given in the various main sections of the manual. These are grouped together in separate sub-sections for convenient reference.

Bolts and nuts should be assembled in a clean and very lightly oiled condition and faces and threads should always be inspected to make sure that they are free from damage burrs or scoring. DO NOT degrease bolts or nuts.

All joint washers, gaskets, tabs and lock washers, split pins and "O" rings must be replaced on assembly. Seals will, in the majority of cases, also need to be replaced, if the shaft and seal have been separated. Always lubricate the lip of the seal before assembly and take care that the seal lip is facing the correct direction.

References to the left-hand and right-hand sides are always to be taken as if the observer is at the rear of the vehicle, facing forwards, unless otherwise stated.

Always make sure that the vehicle is adequately supported, and on firm ground, before commencing any work on the underside of the car. A small jack or a make shift prop can be highly dangerous and proper axle stands are an essential requirement for your own safety.

Dirt, grease and mineral oil will rapidly destroy the seals of the hydraulic system and even the smallest amounts must be prevented from entering the system or coming into contact with the components. Use clean brake fluid or one of the proprietary cleaners to wash the hydraulic system parts. An acceptable alternative cleaner is methylated spirit, but if this is used, it should not be allowed to remain in contact with the rubber parts for longer than necessary. It is also important that all traces of the fluid should be removed from the system before final assembly.

Always use genuine manufacturer's spares and replacements for the best results.

Since the manufacturer uses metric units when building the cars it is recommended that these are used for all precise units. Inch conversions are given in most cases but these are not necessarily precise conversions, being rounded off for the unimportant values.

Removal and installation instructions, in this Workshop Manual, cover the steps to take away or put back the unit or part in question. Other instructions, usually headed "Servicing", will cover the dismantling and repair of the unit once it has been stripped from the vehicle if it is pointed out that the major instructions cover a complete overhaul of all parts but, obviously, this will not always be either necessary and should not be carried out needlessly.

There are a number of variations in unit parts on the range of vehicles covered in this Workshop Manual. We strongly recommend that you take care to identify the precise model, and the year of manufacture, before obtaining any spares or replacement parts.

- Std.: To indicate sizes and limits of components as supplied by the manufacturer. Also to indicate the production tolerances of new unused parts.
- O/S Parts supplied as Oversize or Undersize or recommended limits for such parts, to enable them to be used with worn or re-machined mating parts.
- U/S O/S indicates a part that is larger than Std. size U/S may indicate a bore of a bushing or female part that is smaller than Std.
- Max.: Where given against a clearance or dimension indicates the maximum allowable if in excess of the value given it is recommended that the appropriate part is fitted.
- TIR: Indicates the Total Indicator Reading as shown by a dial indicator (dial gauge).
- TDC: Top Dead Centre (No. 1 piston on firing stroke).
- MP: Multi-Purpose grease.

0.4. Jacking up of the Vehicle

For small jobs, jack up the vehicle as described in the Owner's Manual, with the hydraulic jack supplied with the vehicle. If a mobile jack is used, make sure it can take the weight of the vehicle. Additional weights should always be removed from the cargo room of the vehicle.

To jack up the vehicle completely, first jack up the front end. Chock the rear wheels to prevent the vehicle from rolling off the jack or apply the handbrake. Place a mobile jack underneath the front axle. If the hydraulic vehicle jack is used, place it underneath the front spring as shown in Fig. 04, immediately in front of the front axle.

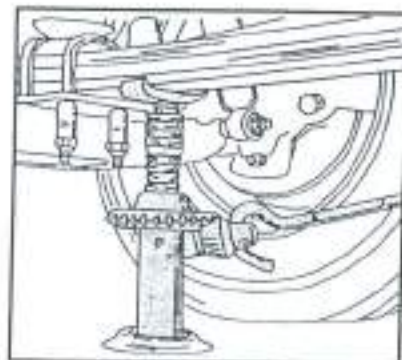

Fig. 0.4 - Jacking up the front end of the vehicle, using the hydraulic jack supplied with the vehicle.

Chassis stands should only be placed on the L.H. and R.H. sides under the front axle. Use chassis stands of the construction shown in Fig. 0.5, should be used, but again make sure that they are strong enough to carry the weight of the vehicle. Make sure the vehicle cannot slip off the stands.

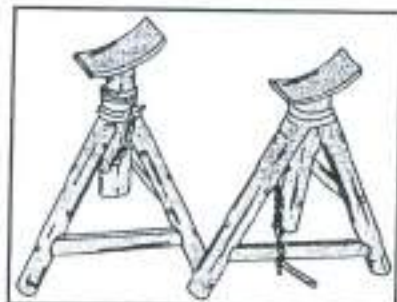

Fig. 0.5 - Three-legged chassis stands are the safest method to support the vehicle when work has to be carried out on the underside of the vehicle.

The rear end of the vehicle is jacked up with a mobile jack or with the hydraulic jack shown in Fig. 0.6. Chassis stands are placed underneath the axle beam, noting the points given above. Again make sure that no additional weights are left in the cargo room.

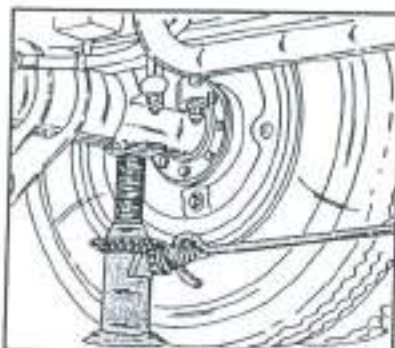

Fig. 0.6 - Jacking up the rear end of the vehicle with the hydraulic jack supplied.

Note: It is always difficult to raise a vehicle first on one side and then on the other. Take care that the vehicle cannot tip-over when the first side is lifted. Ask a helper to support the vehicle from the other side. Never work underneath the vehicle without adequate support.

1 ENGINES

1.0. Technical Data

Fitted Engines:

- 206 D (Model 601.3)	601.940
- 308 D (Model 602.3)	601.940
- 408 D (Model 611.3)	602.940
- 210 D (Model 601.4)	602.940
- 310 D (Model 602.4)	602.940
- 410 D (Model 611.4)	602.940
- L207D	616.017
- L207D, L307D	616.934

Number of Cylinders:

- 601 engine	Four
- 602 engine	Five
- 616 engine	Four

Injection Order:

- Four cylinder	1 - 3 - 4 - 2
- Five cylinder	1 - 2 - 4 - 5 - 3

Arrangement of cylinders

Camshaft

Arrangement of valves

Cylinder bore, 601, 602 engines

- 616 engine	89.00 mm (3.4585 in.)
- Piston stroke, 601, 602, 616 engines	91.00 mm (3.6154 in.)
	92.40 mm (3.6711 in.)

Capacity:

- 601 engine	2299 ccm
- 602 engine	2874 ccm
- 616 engine	2404 ccm

Compression Ratio:

- 601, 602 engines	22 : 1
- 616 engine	21 : 1

Max. B.H.P. (DIN):

- 601 engine, with manual gearbox	58 kW at 3800 rpm
- 601 engine, with A/T	60 kW at 4000 rpm
- 602 engine, with manual gearbox	70 kW at 3800 rpm
- 602 engine, with A/T	72 kW at 4000 rpm
- 616 engine	48 kW at 4200 rpm

Max. Torque:

- 601 engine	15.7 kgm (113 ft.lb.) at 2000 - 2800 rpm
- 602 engine	19.2 kgm (138 ft.lb.) at 2400 - 2600 rpm
- 616 engine	13.7 kgm (99 ft.lb.) at 2400 rpm

Crankshaft bearings	5 or 6 friction bearings
Cooling system	Thermo system with water pump, thermostat, cooling fan with fluid clutch, tube-type radiator

Lubrication	Pressure-feed lubrication with gear-type oil pump, driven with chain from crankshaft. With full-flow oil filter
Air cleaner	Dry paper element air cleaner

Valve Timing – New Timing Chain – 601 and 602 engines:

- Inlet valve opens	11° A.T.D.C
- Inlet valve closes	17° A.B.D.C.
- Exhaust valve opens	28° B.B.D.C.
- Exhaust valve closes	15° B.T.D.C

Valve Timing – Used Timing Chain (after 12 000 miles) – 601 and 602 engines:

- Inlet valve opens	12° A.T.D.C
- Inlet valve closes	18° A.B.D.C.
- Exhaust valve opens	27° B.B.D.C.
- Exhaust valve closes	14° B.T.D.C

Valve Timing – New Timing Chain – 616 engine:

- Inlet valve opens	11.5° A.T.D.C
- Inlet valve closes	13.5° A.B.D.C.
- Exhaust valve opens	21° B.B.D.C.
- Exhaust valve closes	19° B.T.D.C

Valve Timing – Used Timing Chain – 616 engine:

All valves	2° more
------------	---------

Valve Clearances – 616 Engine – Engine warm:

- Inlet valves	0.10 mm (0.004 in.)
- Exhaust valves	0.30 mm (0.012 in.)

Valve Clearances – 616 Engine – Engine cold:

- Inlet valves	0.15 mm (0.006 in.)
- Exhaust valves	0.35 mm (0.018 in.)

1.1. Engine – Removal and Installation

The engine and transmission is removed from the vehicle as a complete unit after the parts shown in Fig. 1.1 are removed from the front end of the vehicle. The transmission can then be removed from the engine. Engine and transmission are a heavy unit and a suitable hoist or crane is required to lift out the assembly, remembering that the weight is more than 200 lbs. The following description is a general guide line, as we cannot refer to every possible variation and/or equipment that may be fitted to your vehicle.

- Place the bonnet into the vertical position until the lock engages. Remove the drivers seat.

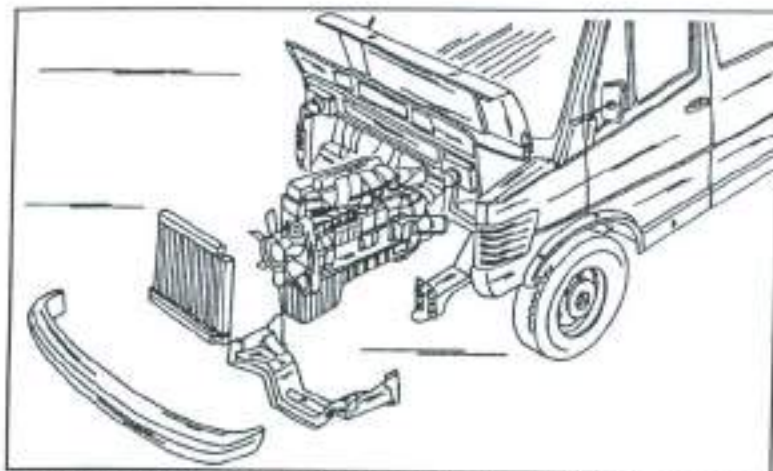

Fig. 1.1 – The engine is removed from the vehicle after the illustrated parts have been removed from the front end of the vehicle.

- Disconnect the two battery cables. The battery can also be removed to have more space for other operations.
- Remove the engine cover and the radiator grille.
- Open the expansion tank cap. It is assumed that the engine is fairly cold. Drain the cooling system as described in Section "Cooling System". Remove the radiator as described in the same section.
- Remove the air intake hose.
- Remove the front bumper and the radiator crossmember (Fig. 1.1).
- Separate the front exhaust pipe from the exhaust manifold and free the pipe from the bracket on the transmission.
- Disconnect the propeller shaft from the transmission. Also disconnect the speedometer cable from the transmission.
- Unscrew the clutch slave cylinder from the side of the transmission without disconnecting the hydraulic hose. Tie the cylinder to the vehicle floor to prevent it from hanging down on its hose. Fig. 1.2 shows where the cylinder is attached.
- Unscrew the earth cable.

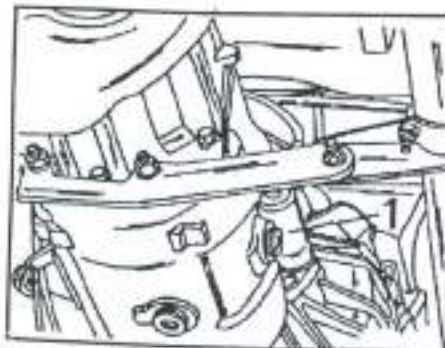

Fig. 1.2 – The clutch slave cylinder (1) is fitted to the side of the transmission.

- Disconnect the electrical leads from the starter motor and the alternator. Free the cable harness from the engine (cut the cable binders) and push the harness to one side, where it cannot be in the way during following operations.
- Disconnect the electrical lead from the glow plug relay.
- Disconnect all vacuum hoses from the engine.

- If a power-assisted steering is fitted, remove the drive belt and unscrew the belt pulley from the pump shaft. Unscrew the complete steering pump and remove it together with the connected hoses.
- Disconnect the fuel pipe from the pre-filter. Close the open connections in suitable manner to prevent entry of dirt.
- Remove the vacuum hose from the vacuum pump at the location shown in Fig. 1.3.

Fig. 1.3 - Disconnect the vacuum hose for the brake servo unit from the vacuum pump (exhauster pump).

- Unscrew the gear change lever knob, remove the rubber gaiter and withdraw the lever after removing the clamp bolt. During later installation tighten the clamp bolt until the gap is 1.5 mm.
- Slacken the heater hose behind the thermostat housing and withdraw.
- Remove the starter motor.

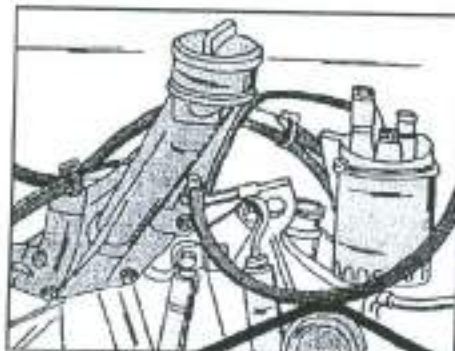
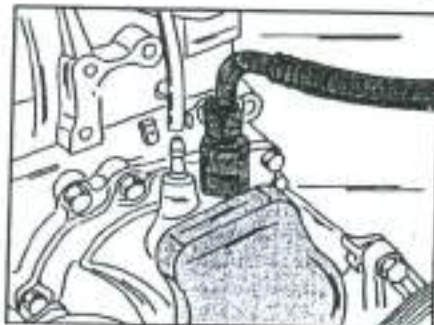

Fig. 1.4 - The oil filler neck must be removed in order to take out the engine.

- Disconnect the oil pipes from the oil filter housing.
- Remove the pipe clamp from the oil sump.
- Remove the oil filler neck. Fig. 1.4 shows the location.
- Remove the transmission mounting from the crossmember (1 bolt).
- Slacken the engine mounting supports from the engine mounting.

Fig. 1.5 - The attachment of the crossmember underneath the vehicle.

- Use a hand crane or suitable hoist and with ropes or chains attach the power unit, utilising the lifting eyes. Also place a mobile jack underneath the engine/transmission unit to support it from below. Before removing any of the engine and transmission mountings ensure that the weight of the assembly is well supported.
- Disconnect the throttle control.
- Unscrew the crossmember underneath the transmission and also underneath the engine. Figs. 1.5 and 1.6 show where the items are attached. Check once more that the unit is supported.



- Lift the engine/transmission assembly towards the front of the vehicle, turning it slightly to allow the gearchange to clear the engine compartment. If the unit is resting on a jack, remove the jack at the same time. Helpers will be required to guide the power unit. Finally lower the assembly to the ground. Remove the transmission if required.



Fig. 1.6 - The attachment of the engine crossmember.

The installation is a reversal of the removal procedure, but the following points should be noted:

- Check the engine mountings and the oil and fuel pipes (hoses) for damage and replace parts as necessary.
- If a manual transmission is fitted, take the opportunity to check the clutch release bearing and replace if necessary.
- Do not connect or refit any of the

disconnected parts until the engine and transmission are refitted to their mountings and the engine is free from the ropes or chains.

- Remove the engine mounts if their conditions require it. Keep oil or grease away from the rubber parts.
- Connect the propeller shaft in accordance with the instructions in Section 4.
- Refill the cooling system with anti-freeze of the correct strength for the temperatures to be expected. If the original anti/freezes is used, check its strength before filling it in.
- Check the air cleaner element before re-use. Dirty elements should be replaced, mainly if overhaul work has been undertaken on the engine.
- Check the oil levels in engine and transmission and correct if necessary, if no other operations have been carried out on the units.
- After starting the engine and allowing it to warm up, check the cooling system for leaks. Drive the vehicle a few miles to check for exhaust pipe rattle.

1.2. Engine - Dismantling

Diesel engines are sensitive to dirt or other contamination. It is therefore essential to make sure that no foreign matter can enter the pipes, connections, etc. during the dismantling operations.

Dismantling of the engine will be made much easier, if a swivelling engine stand is available. Otherwise place the engine/transmission on a work bench, supporting it adequately to prevent it from falling over.

Before commencing dismantling, block up the inlet and exhaust openings and give the exterior of the engine a thorough cleaning to remove all loose dirt and oil. Pay particular attention to all joint surfaces, brushing these to remove loose debris which might otherwise find its way into the interior of the engine.

Many of the parts are made of Aluminium alloy and must be treated accordingly. Only use plastic or rubber mallets to separate parts, if necessary.

As a complete strip-down of the engine is in most cases not necessary, and many of the operations can be carried out with the engine fitted, you will find in the following text

a description of individual operations which can be carried out with the engine fitted and removed. Combining these, will give you the complete dismantling of the engine.

1.3. Engine - Overhaul

1.3.0. Cylinder Head and Valves - Technical Data

Cylinder Head:

Cylinder head height:	142.9 - 143.1 mm
- 616 engine	84.8 - 85.00 mm (min. 84.00 mm)

Max. Distortion of Cylinder Head Faces:

- Longitudinal direction:	0.08 mm
- Across the face:	0.00 mm

Max. deviation of faces between upper and lower sealing faces (parallel to each other)

0.10 mm

Depth of valve head faces and cylinder head sealing face - Except 616:

- Inlet valves	+0.17 to 0.23 mm
- Exhaust valves	+0.12 to 0.26 mm
- With re-cut valve seats	1.0 mm - all valves

Depth of valve head faces and cylinder head sealing face - 616:

- Inlet valves	+0.03 to 0.43 mm
- Exhaust valves	- 0.38 to 0.78 mm
- With re-cut valve seats	1.5 mm - all valves

Valves

Valve Head Diameter ("D" in Fig. 1.22):

- Inlet valves	37.90 - 38.10 mm
616 engine	39.70 - 39.90 mm
- Exhaust valves	34.90 - 35.10 mm
616 engine	34.10 - 34.30 mm
Valve seat angle	45° + 15° (616 engine = 30°)

Valve Stem Diameter ("D1" in Fig. 1.22):

- Inlet valves	7.970 - 7.955 mm
- Exhaust valves	8.960 - 8.945 mm
- 616 engine	9.920 - 9.940 mm

Valve Length ("L" in Fig. 1.22):

- Inlet valves	106.50 - 106.30 mm
- Exhaust valves	106.50 - 106.30 mm
616 engine - Inlet valves	131.30 - 131.70 mm
616 engine - Exhaust valves	130.8 - 131.20 mm

Valve Seat Width:

- Inlet valves	2.5 mm (616 = 1.3 to 1.6 mm)
- Exhaust valves	3.5 mm (616 = 2.5 - 2.9 mm)

Valve Identification:

- Inlet valves	E 601 02 (616 = E 616 02)
- Exhaust valves	A 601 02 (616 = A 616 05)

Valve Seats

Valve seat width:

- Inlet valves	2.5 mm (616 = 1.3 to 1.6 mm)
- Exhaust valves	3.5 mm (616 = 2.5 - 2.9 mm)

Valve seat angles

Upper correction angle	45° - 15° (616 = 30°)
Lower correction angle	15° (616 = 60°)
	60° (616 = N/A)

Valve Seat Inserts (only 601 and 602 given)

Insert outer diameter ("D" in Fig. 1.20):

- Inlet valves - Std.	40.100 - 40.084 mm
- Exhaust valves - Std.	37.100 - 37.084 mm

Insert inner diameter ("D1" in Fig. 1.20):

- Inlet valves - Std.	33.400 - 33.600 mm
- Exhaust valves - Std.	30.500 - 30.600 mm

Basic bore in cylinder head ("D2" in Fig. 1.20):

- Inlet valves - Std.	40.000 - 40.016 mm
- Exhaust valves - Std.	37.000 - 37.016 mm
Valve seat height, all valves	6.97 - 7.00 mm

Upper edge of valve seat rings to cylinder head face:

- Inlet valves	2.37 - 2.25 mm
- Exhaust valves	2.44 - 2.25 mm

Valve Springs - Except 616 engine

Colour code	yellow-green or purple-green
Outer diameter	33.20 mm
Wire diameter	4.25 mm
Free length	50.80 mm
Length under load of 72 to 77 kg	27.00 mm
- Wear limit	27.00 mm at 65 kg

Valve Springs - 616 engine

Colour code	green/green or violet/green	yellow/yellow or violet/yellow
Outer diameter	30.20 - 30.5 mm	30.0 - 30.7 mm
Wire diameter	3.80 mm	3.80 mm
Free length	50.50 mm	51.20 mm
Length under load of 46.3 to 53 kg	29.80 mm, min.	-----
Length under load of 58.9 kg	-----	28.00 mm
- Wear limit	41.70 kg	53.00 kg

Valve Guides - Except 616

Inlet valve Guides:	
- Outer diameter - Std.	14.044 - 14.051 mm
- Outer diameter - Repair size	14.214 - 14.222 mm
- Inner diameter	8.000 - 8.015 mm

Basic bore in cylinder head:

- Std.	14.030 - 14.035 mm
- Repair size	14.198 - 14.203 mm

Exhaust Valve Guides:	
- Outer diameter – Std.	14.044 – 14.051 mm
- Outer diameter – Repair size	14.214 – 14.222 mm
- Inner diameter	9.000 – 9.015 mm

Basic bore in cylinder head:	
- Std.	14.030 – 14.035 mm
- Repair size	14.198 – 14.203 mm

Interference fit of valve guides – All guides:	
- Std.	0.009 – 0.021 mm
- Repair size	0.011 – 0.024 mm

Valve Guides – 616

Inlet Valve/Exhaust Valve Guides:

Length:	
Inlet valves	60.0 or 61.0 mm
Exhaust valves	48.5 – 40.5 mm
- Outer diameter – Std., all guides	14.03 – 14.04 mm
- Outer diameter – Repair size, all guides	14.23 – 14.24 mm
- Inner diameter, all guides	10.00 – 10.015 mm
- Max. inner diameter	10.025 mm
Basic bore in cylinder head:	
Std.	14.000 – 14.020 mm
Repair size	14.200 – 14.220 mm
Interference fit of valve guides – All guides:	
Std.	0.01 – 0.04 mm

Camshaft – Except 616 Engine

Camshaft Bearings:

- 4 cal. engine	5
- 5 cal. engine	6
Journal diameter	30.944 – 30.950 mm

Camshaft Bearing Clearance:

- New condition	0.050 – 0.091 mm
- Wear limit	0.11 mm

Camshaft End Float:

- New condition	0.07 – 0.15 mm
- Wear limit	0.18 mm

Camshaft – 616 Engine

Camshaft bearing running clearance	0.025 – 0.066 mm (max. 0.11 mm)
Camshaft end float	0.05 – 0.128 mm (max. 0.18 mm)

1.3.0.1. Cylinder Head – Removal and Installation

The following information should be noted when work is carried out on a cylinder head:

- The cylinder head is made of light-alloy. Engine coolant, engine oil, the air required to ignite the fuel and the exhaust gases are directed through the cylinder head. Glow plugs, injectors, pre-combustion chambers and valve tappets are fitted to the cylinder head. Also in the cylinder heads you will find the camshaft.

- The exhaust manifold and the inlet manifold are bolted to the outside of the head. The fuel enters the head on one side and exits on the other side, i.e. the head is of the well-known "crossflow" type.
- The cylinder head is fitted with various sender units, sensors and switching valves, responsible for certain functions of the temperature control.
- As the cylinder head is made of light alloy, it is prone to distortion if, for example, the order of slackening or tightening of the cylinder head bolts is not observed. For the same reason never remove the cylinder head from a hot engine.
- A cylinder head cannot be checked in fitted position. Sometimes the cylinder head gasket will "blow", allowing air into the cooling system. A quick check is possible after opening the coolant reservoir cap (engine fairly cold). Allow the engine to warm-up and observe the coolant. Visible air bubbles point in most cases to a "blown" gasket. Further evidence is white exhaust smoke, oil in the coolant or coolant in the engine oil. The latter can be checked at the oil dipstick. A white, grey emulsion on the dipstick is more or less a confirmation of a damaged cylinder gasket.
- If you are convinced that water has entered the engine and you want to get home or to the nearest garage, unscrew the injectors and crank the engine with the starter motor for a while to eject the water. Refit the injectors, start the engine and drive to your destination without switching off the engine. This is the only method to avoid serious engine damage (bent connecting rods for example).

The cylinder head must only be removed when the engine is cold. The head is removed together with the exhaust manifold, but the inlet manifold must be separated from the cylinder head before the head can be lifted off. New cylinder head gaskets are wrapped in plastic and must only be unwrapped just before the gasket is fitted. The cylinder head can be removed with the engine fitted and these operations are described below, but note that operations may vary, depending on the equipment fitted:

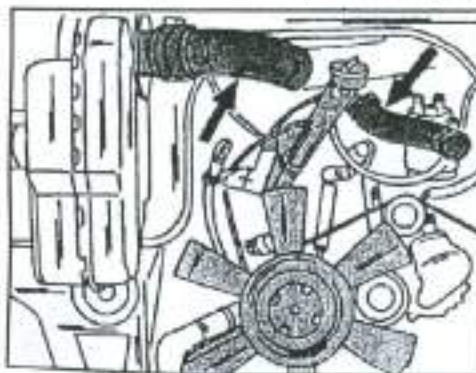

Fig. 1.7 – Remove the two hoses shown by the arrows after slackening the hose clamps.

- Remove the driver's seat, disconnect the battery earth cable and remove the engine bonnet.
- Drain the cooling system (Section 1.8.1.) and remove the radiator.
- Lift up the radiator grill and lock it in the raised position.
- Disconnect the air intake hose and the coolant hose shown in Fig. 1.7.
- Remove the visco-clutch from the front end of the engine. Do not store the clutch assembly in vertical position.
- Remove the oil filler elbow (Fig. 1.4).
- Cut the cable binder securing the engine cable harness.
- Remove the single poly V-belt from the front of the engine. To do this, refer to Fig. 1.8 and slacken the flanged nut. Insert a drift of 12 mm diameter and 180 mm in length into the spring-loaded lever and push the tensioning device towards the left. Relieve the tension from the securing screw until the tensioning spring can be pushed in direction inlet manifold. Now remove the bolt (3) securing the mounting

shock absorber (see also Fig. 1.9) and remove the tensioning device. Push down on the tensioning pulley to loosen and remove the belt.

Fig. 1.8 – Releasing the tension of the drive belt at the front end of the engine.

- 1 Tensioning spring
- 2 Damper
- 3 Bracket for tensioner

- If a power-assisted steering is fitted, remove the pulley for the drive belt.
- Disconnect all coolant, fuel and vacuum hoses and the electrical cables connected to the cylinder head or any other unit on the cylinder head which cannot be removed together with the cylinder head (also see below).

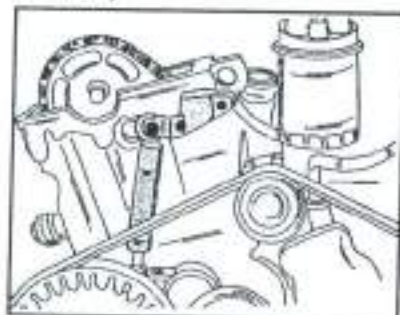
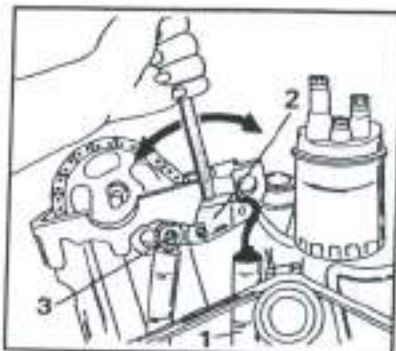

Fig. 1.9 – Unscrew the damper for the belt tensioning device from the cylinder head end.

- Separate the throttle control linkage at the ball joint connection.
- Disconnect the vacuum pipes from the exhaustor (vacuum) pump. One hose and one union nut must be removed.
- Use suitable clamps and clamp-off the fuel hoses and disconnect the fuel hoses at the fuel pre-filter or remove the fuel filter bracket and tie it up with a piece of wire.
- In the case of a four cylinder engine

remove the injection pipes of cylinder Nos. 1, 2 and 3 together with the pipe bracket and remove the injection pipe of No. 4 cylinder without the bracket. On a five-cylinder engine, the injection pipes of Nos. 4 and 5 cylinder are held together by means of a plastic clip. Also withdraw the leak-off hose at the injector of the No. 1 cylinder. Close off the hose end in suitable manner (a bolt of suitable diameter can be pushed into the hose end).

- Remove the damper for the engine speed regulation from the inlet manifold. This is the item shown in Fig. 1.10.

Fig. 1.10 – The damper for the engine speed regulation is attached to the manifold.

- Disconnect the vacuum hose from the thermo valve.
- Disconnect the electrical leads from the glow plugs.
- Remove the securing clip for the heater assembly feed pipe with a wire hook. Remove the connectors from the oil filter and on the other end.
- Disconnect the exhaust pipe flange



from the exhaust manifold and unscrew the exhaust pipe support bracket from the transmission.

- Remove the inlet (intake) manifold.

Fig. 1.11 – Removal of an injector.

- Remove the cylinder head cover. Six screws must be removed. Two are located on each long side of the cover and two on the timing side of the engine. If an automatic transmission is fitted, there is a regulating rod fitted across the cylinder head cover, which must be separated on one side at the ball joint. A sticking cylinder head cover must not be freed by tapping it with a hammer. If difficult to remove, try to unstick it by pushing it by hand to one side. Use a plastic mallet, if necessary.
- Unscrew the injectors (Fig. 1.11) and remove the washers underneath.
- Rotate the engine until the piston of No. 1 cylinder is at top dead centre in the firing position, i.e. the "0" mark must be opposite the adjusting pin, as shown in Fig. 1.12. A 27 mm socket can be applied to the crankshaft pulley to rotate the crankshaft.

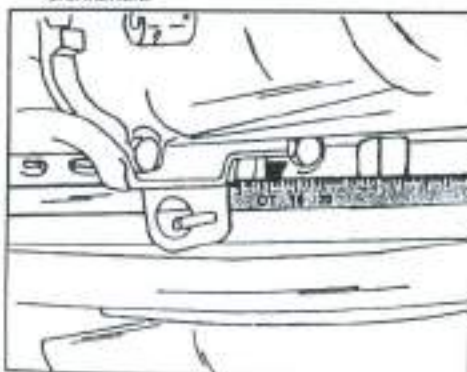
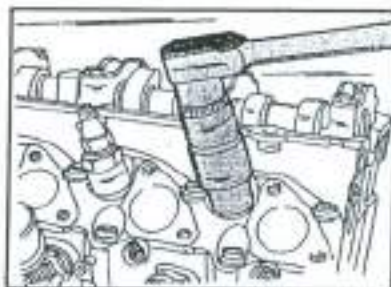

Fig. 1.12 – Dead centre position of the engine.

Never attempt to rotate the crankshaft by applying a socket to the camshaft timing wheel bolt. The crankshaft must be rotated in the direction of rotation.

- Remove the chain tensioner as described in Section 1.3.5.0. The chain tensioner plug must be unscrewed by applying a spanner to the hexagon. The plug is located above the water pump and the thermostat cover, next to the

large tube.

- Mark the camshaft sprocket and the timing chain at opposite points, as shown in Fig. 1.13, using a spot of paint.

Fig. 1.13 – Mark the chain and sprocket with a spot of paint before removal of the sprocket.

- Unscrew the camshaft sprocket bolt. To counterhold the camshaft against rotation, insert a strong screwdriver blade or steel bolt into one of the holes of the camshaft sprocket.
- Remove the camshaft sprocket from the shaft without



disengaging the timing chain from the crankshaft sprocket. Put the chain tight and use a piece of wire to tie chain and sprocket together.

- Remove the camshaft as described under the relevant section.
- Remove the slide rail from the cylinder head as described later on.
- In the inside of the chain case remove two 8 mm socket head bolts with an Allen key. An extension and a socket is required to reach the bolts.
- Unscrew the cylinder head bolts in reverse order to the one shown in Fig. 1.14 or 1.15. A multi-spline bit must be used to slacken the bolts (MB Part No. 601 589 00 10 00). A normal Allen key is not suitable as it

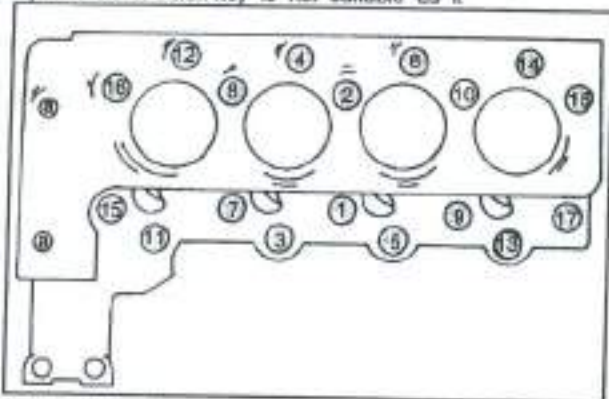

Fig. 1.14 – Tightening sequence for the cylinder head bolts for the 601 engine. The bolts "a" on the L.H. side are the smaller bolts mentioned in the text. Slacken the bolts in reverse order.

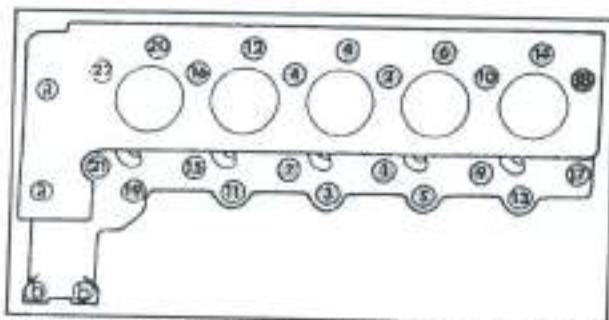

Fig. 1.15 – Tightening sequence for the cylinder head bolts for the 601 engine. The bolts "a" on the L.H. side are the smaller bolts mentioned in the text. Tighten the bolts in reverse order.

will damage the bolt heads. Immediately after removal of the bolts measure their length. If the dimension from the end of the bolt to the underside of the bolt head is more than 83.6, 105.6 or 118.5 mm, depending where the bolts are located, replace the bolts. New bolts have a length of 80 mm, 102.0 mm or 150.0 mm. I.e. bolts which nearly approach the max. length should also be replaced.

Note: Certain bolts are fitted through the camshaft bearings. As the cylinder head bolts are of different length, mark them before removal to assure refitting in the original positions.

- Lift off the cylinder head. If a hoist or other lifting equipment is available, hook a rope to the two lifting eyes and lift off the head. Remove the cylinder head gasket.
- Immediately after removal, clean the cylinder head and block surfaces of old gasket material.
- If necessary, overhaul the cylinder head as described in Section 1.3.0.2. after dismantling.

Install the cylinder head in the following manner:

- Place a new cylinder head gasket in position.
- Place the cylinder head carefully in position, taking care to engage the dowel sleeves. Use a soft-faced mallet to tap the head in position.
- Coat the threads of the cylinder head bolts and the underside of the bolt heads with oil. It is assumed that original bolts have been measured for their re-use.
- Insert the cylinder head bolts as originally fitted (and hopefully marked) and tighten them in the sequence shown in Figs. 1.14 or 1.15 in several stages. The tightening is carried out in stages as follows:
 - Tighten all bolts in the correct order to 1.5 kgm (11 f.l.b.).
 - Tighten all bolts in the correct order to 3.5 kgm (30 f.l.b.).
 - Wait 10 minutes.
 - Angle-tighten all bolts in their correct tightening order. To do this, insert the multi-spline bit with the socket into each bolt and fit the tommy bar so that it is in line with the longitudinal axis of the engine. Tighten the bolt until the tommy bar is at right angle to the engine, i.e. the bolt has been tightened by 90° (1/4 of a turn). Do not use the torque wrench for this operation.
 - Re-tighten each bolt in the order given by a further 90° in the manner described above.
- Fit the two socket head screws to the inside of the timing chain chamber and tighten them to 2.5 kgm (18 f.l.b.).

Note: Multi-spline head socket bolts require no re-tightening after they have been fitted as described above.

Cylinder heads are sometimes modified. When for example fitting a second head cylinder head at some stage, make sure it is the correct one.

- Refit the slide rail to the head as described later on (Section 1.3.5.3.).
- Fit the camshaft sprocket together with the timing chain to the end of the camshaft, making sure that the paint marks made during removal are in line. The sprocket must engage with its bore over the dowel pin in the camshaft.
- Fit the camshaft sprocket bolt and tighten the bolt to 4.5 kgm (32.5 f.l.b.). Counterhold the camshaft by inserting a strong screwdriver blade or steel bolts through one of the openings in the sprocket.
- Refit the timing chain tensioner and tighten the plug to 8.0 kgm (58.5 f.l.b.).
- Check the marking for top dead centre for the No. 1 cylinder in the camshaft (see Fig. 1.16). A notch is machined into the camshaft which should be in line with a mark machined into the cylinder head. The alignment can be seen by looking from above and comparing it with Fig. 1.16.
- Re-connect the glow plug cables.
- Refit the inlet manifold. And the injectors and re-connect the injection pipes.
- Fit the tube elbow with a new "O" sealing ring.

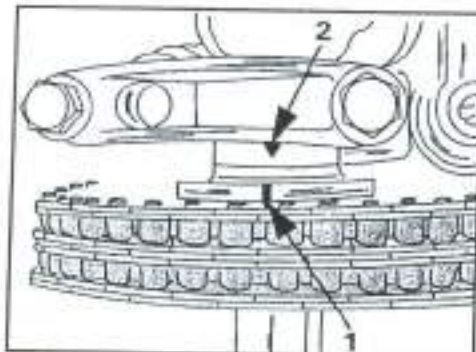

Fig. 1.16 - Alignment of the notch in the camshaft flange (1) and the lug on the No. 1 camshaft bearing cap (2) assures the T.D.C. position of the engine.

- Fit the exhaust pipe to the exhaust manifold.
- The remaining operations are carried out in reverse order to the removal procedure. Check and, if necessary adjust, the throttle cable operation.

1.3.0.2. Cylinder Head - Dismantling

The following description assumes that the cylinder head is to be replaced. If only a top overhaul is asked for, ignore the additional instructions. The cylinder head must be removed.

The valve stem oil seals can be replaced with the cylinder head fitted. Signs of worn oil seals are blue exhaust smoke when the vehicle is coasting (gear engaged), when the engine is accelerated after idling for a while or blue smoke when starting the cold engine. If the oil consumption has reached 1 litre per 600 miles, replace the valve stem oil seals as described under a separate heading.

Proceed as follows during dismantling:

- Remove all auxiliary parts from the cylinder head, including the exhaust manifold.
- Remove the camshaft. All camshaft bearing brackets must be removed and the camshaft lifted out. Each bearing bracket is marked with a number. A corresponding number is marked into the cylinder head, i.e. there is no need to mark the bearing brackets.
- A valve spring compressor is required to remove the valves. Valves are held in position by means of valve cotter halves. Compress the springs and remove the valve cotter halves with a pair of pointed pliers or a small magnet.

If a valve spring compressor is not available, it is possible to use a short piece of tube to remove the valve cotter halves. To do this, place the tube over the upper valve spring collar and hit the tube with a blow of a hammer. The valve cotter halves will collect in the inside of the tube and the components can be removed. The valve head must be supported from the other side of the cylinder head. Keep the hammer in close contact with the tube to prevent the cotter halves from flying out.

- Remove the valve spring collar and the valve spring. The valve springs (one spring per valve) are identified with a paint spot and only a spring with a paint spot of the same colour must be fitted. A thrust ring is fitted underneath each valve spring and can be removed. Figs. 1.17 and 1.18 show sectional views of the two valve assemblies.
- Remove valve stem oil seals carefully with a screwdriver or a pair of pliers.

Remove the valves one after the other out of the valve guides and pierce them in their fitted order through a piece of cardboard. Write the cylinder number against each valve if they are to be re-used.

Fig. 1.17 - Sectional view of the cylinder head and an inlet valve.

1. Cylinder head
2. Inlet valve seat ring
3. Inlet valve guide
4. Oil passage
5. Welsh plug
6. Bearing cap
7. Bolt, M8 x 45
8. Washer
9. Camshaft
10. Inlet valve
11. Thrust ring
12. Lock ring
13. Valve spring
14. Valve stem oil seal
15. Valve spring retainer
16. Valve cotter halves
17. Valve tappet with hydraulic compensating element

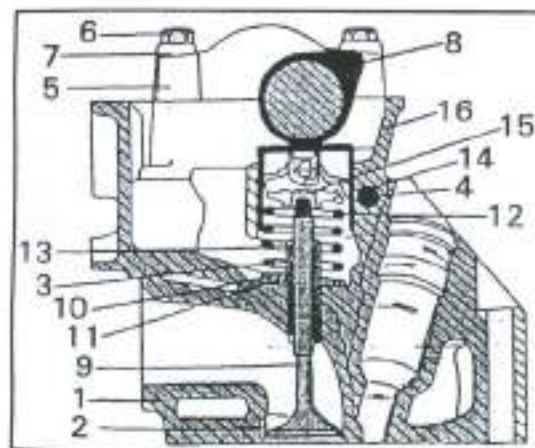
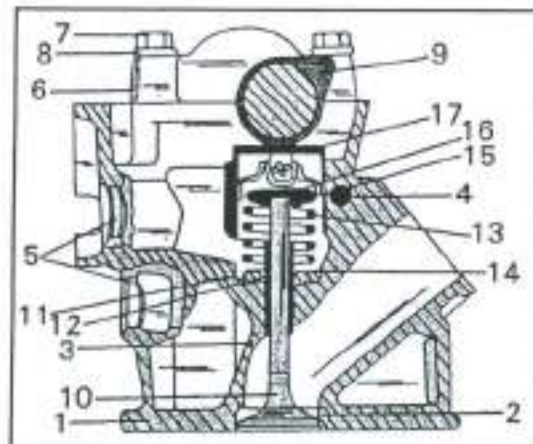

Fig. 1.18 - Sectional view of the cylinder head and an exhaust valve.

1. Cylinder head
2. Exhaust valve seat ring
3. Exhaust valve guide
4. Oil passage
5. Bearing cap
6. Bolt, M5 x 45
7. Washer
8. Camshaft
9. Exhaust valve
10. Thrust ring
11. Lock ring
12. Valve spring
13. Valve stem oil seal
14. Valve spring retainer
15. Valve cotter halves
16. Hydraulic valve tappet

A few words should be said about the camshaft (applicable to 601 and 602 engines). The camshaft of a four-cylinder engine has five bearings, the shaft of a five-cylinder engine has six bearings, the six cylinder has seven. All bearings have the same diameter of 31.0 mm. The lower part of the bearing location is machined directly into the cylinder head. The camshaft is located in axial direction by means of a retaining ring, which is secured to the cylinder head and engages into a groove at the front end of the cylinder head.

The camshaft flange is marked with a line. Next to the line is an identification number. If a shaft is replaced, only fit a shaft with the same number. The parts lists will have the correct camshaft for the engine in question.

1.3.0.3. Cylinder Head - Overhaul

The cylinder head must be thoroughly cleaned and remains of old gasket material removed. The checks and inspections are to be carried out as required.

Valve Springs: If the engine has a high mileage, always replace the valve springs as a set. To check a valve spring, place the old spring and a new spring end to end over a long bolt (with washer under bolt head) and fit a nut (again with a washer). Tighten the nut until the springs are under tension and measure the length of the two springs. If the old spring is shorter by more than 10%, replace the complete spring set. When a spring tester is available, check the spring length when the loads given in Section 1.3.0. are applied.

The springs must not be distorted. A spring placed with its flat coil on a surface must not deviate at the top by more than 2 mm (0.08 in.).

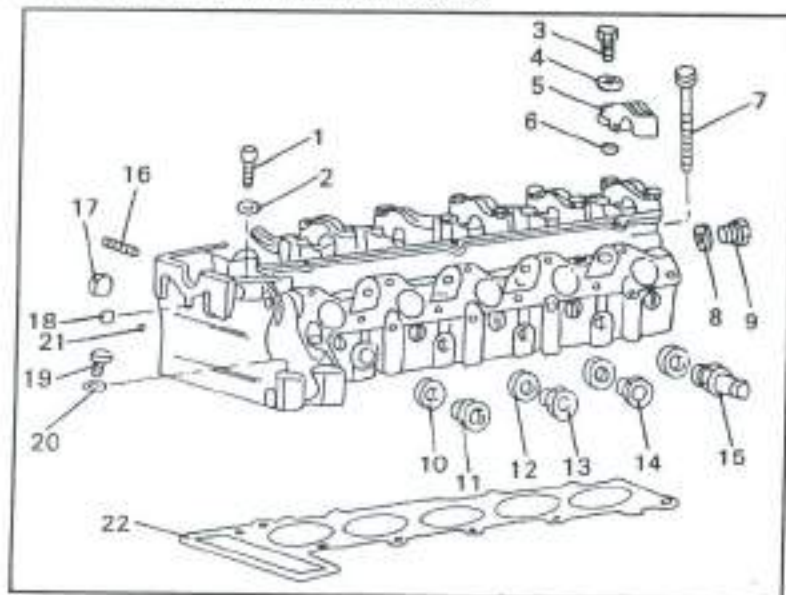

Fig. 1.19 - Exploded view of the cylinder head of a 602 engine.

- | | |
|--------------------------|---|
| 1. Bolt in chain chamber | 12. Sealing ring |
| 2. Wave washer | 13. Connector for temperature sender unit |
| 3. Bearing cap bolt | 14. Threaded insert |
| 4. Plain washer | 15. Heater connection |
| 5. Camshaft bearing cap | 16. Stud, exhaust manifold |
| 6. Dowel pin | 17. Welsh plug |
| 7. Cylinder head bolt | 18. Steel ball, oil gallery |
| 8. Sealing ring | 19. Bolt, fuel filter |
| 9. Plug, oil gallery | 20. Plain washer |
| 10. Sealing ring | 21. Steel ball, coolant circuit |
| 11. Same as 13 | 22. Cylinder head gasket |

Valve Guides: Valve guides for inlet and exhaust valves are made of cast iron and have different diameters. Guides for exhaust valves are shorter and have a larger inner diameter.

Clean the inside of the guides by pulling a petrol-soaked cloth through the guides. Valve stems can be cleaned best by means of a rotating wire brush. Measure the inside diameter of the guides. As an inside micrometer is necessary for this operation, which is not always available, you can insert the valve into its guide and withdraw it until the valve head is approx. level with the cylinder head face. Rock the valve to and fro and check for play. Although no exact values are available, it can be assumed that the play should not exceed 1.0 - 1.2 mm (0.04 - 0.047 in.). Mercedes workshops use gauges to check the guides for wear.

Guides are removed with a shouldered mandrel from the combustion chamber side of the cylinder head. If guides with nominal dimension 1 can be used, drive them in position, until the retaining is resting against the cylinder head. If repair guides are fitted, the locating bores in the cylinder head must be reamed out to take the new guides. As dry ice is required to fit the new valve guides, we recommend to have the work carried out in a workshop.

Before a valve guide is replaced, check the general condition of the cylinder head. The guides must be reamed after installation, and after the cylinder head has cooled down, if applicable, to their correct internal diameter, given in Section 1.3.0, noting the different diameters for inlet and exhaust valves.

Valves must always be replaced if new valve guides are fitted. The valve seats must be re-cut when a guide has been replaced. If it is obvious that seats cannot be re-ground in the present condition, new valve seat inserts must be fitted.

Again this is an operation for a specialist and the work should be carried out in a workshop.

Valve Seats: If the camshaft bearings are excessively worn, fit a new or exchange cylinder head. In this case there is no need to renovate the valve seats.

Check all valve seats for signs of pitting or wear. Slight indentations can be removed with a 45° cutter. If this operation is carried out properly, there should be no need to grind-in the valves. Use correction cutters to bring the valve seating area into the

Fig. 1.20. - Principal dimensions of a valve seat (601/602).

- | Description | |
|-------------|---|
| D | Outer diameter of seat ring |
| D1 | Inner diameter of seat ring |
| D2 | Locating bore in cylinder head |
| H | Height of valve seat ring |
| T | Dimension between head face and upper face of valve seat ring |
-
- | Dimensions | |
|------------|------------------------------------|
| D | 40,100 - 40,084 mm, inlet valve |
| D1 | 33,400 - 33,600 mm, exhaust valves |
| D2 | 40,000 - 40,016 mm, inlet valves |
| H | 6.97 - 7.0 mm |
| T | 2.37 - 2.25 mm, inlet valves |
| | 2.44 - 2.25 mm, exhaust valves |

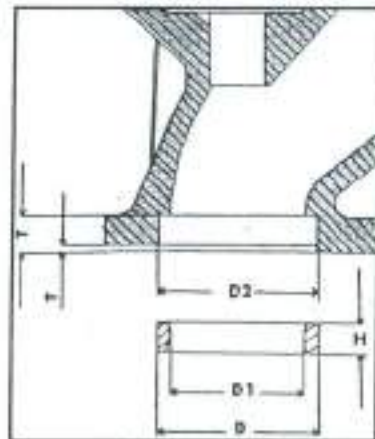

centre of the valve seat. Make sure that the valve seat width, given in Section 1.3.0, is obtained. This again is achieved by using cutters of different angles (for example 15° and 60°). Valve seat inserts can be fitted to the cylinder head. Replacement of valve seat inserts will require that the old seat insert is removed by machining. The machining must not damage the bottom face of the head recess.

As this is a critical operation, we advise you to bring the cylinder head to your Mercedes Dealer who has the necessary equipment and experience to do the job. Fig. 1.20 shows a valve seat. It may be possible to obtain a reconditioned cylinder head in exchange for the old one to avoid time delay. In this case remove all ancillary parts from the old head and refit them to the new head.

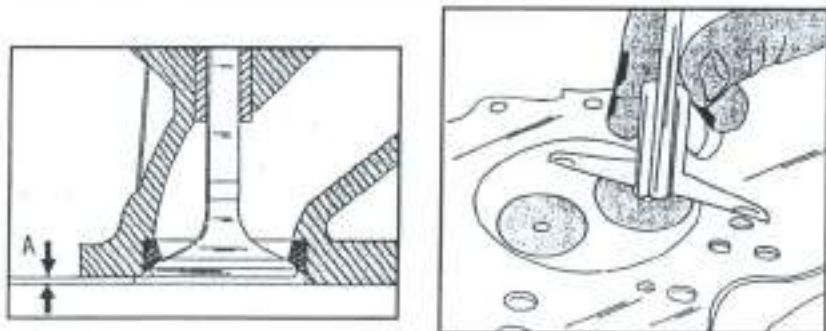

Fig. 1.21 - The maximum dimension "A" between the valve face and cylinder head face is shown on the L.H. side. Measure this dimension as shown on the R.H. side.

If the valve seats have been re-cut, use the valve and measure the dimension "A" in Fig. 1.21. To do this, insert the valve into the respective bore and, using a depth gauge, measure the gap between the cylinder head face and the valve face, as shown on the R.H. side in Fig. 1.21. The dimension must be between 0.1 and 0.5 mm in the case of new valves. The wear limit is 1.0 mm.

Valves can be ground into their seats in the conventional manner.

Valves: The stems of inlet valves and exhaust valves have been specially treated, i.e. the ends of the valve stems must not be ground off.

Valves can be cleaned best with a rotating wire brush. Check the valve faces for wear or grooving. If the wear is only slight, valves can be re-ground to their original angle in a valve grinding machine, but make sure that there is enough material left to have an edge on the valve head. The valve head thickness must be 0.5 - 0.7 mm in the case of the inlet valves and 0.5 - 0.6 mm in the case of the exhaust valves.

Measure the valves in accordance with the values given in Section 1.3.0 and Fig. 1.22 and replace any valve which is outside the limits given. Note that the valves are not filled with sodium, as is the case with other Mercedes engines.

Check the valve stem diameters and in this connection the inside diameters of the valve guides. If there is a deviation from the nominal values, it may be necessary to replace the valve guides (see above). Also check the end of the valve stems. There should be no visible wear in this area.

Always quote the model year and the engine number when ordering new valves, as different valves are used. These are marked by means of a number in the end of the valve stem. The numbers can be found in Section 1.3.0.

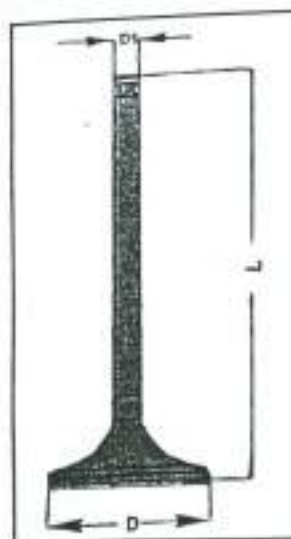

Fig. 1.22 - Principal valve dimensions.

D = Valve head diameter

D1 = Stem diameter

L = Length

Sometimes it is only required to replace the exhaust valves, if these for example are burnt out at their valve head edges.

Cylinder Head: Thoroughly clean the cylinder head and cylinder block surfaces of old gasket material and check the faces for distortion. To do this, place a steel ruler with a sharp edge over the cylinder head face and measure the gap between ruler and face with feeler gauges. Checks must be carried out in longitudinal and diagonal direction and across the face. If a feeler gauge of more than 0.10 mm (0.004 in.) can be inserted, when the ruler is placed along or across the cylinder head, have the cylinder head face re-ground. The dimension between the face of the valve heads and the cylinder head face ("A" in Fig. 1.21) will change after regrinding, but the workshop

will correct it accordingly.

A further check must be carried out on the pre-combustion chambers for the fuel injection. These must protrude by 7.6 - 8.1 mm. Mercedes workshops correct this dimension by fitting sealing washers of different thicknesses, to correct the protrusion.

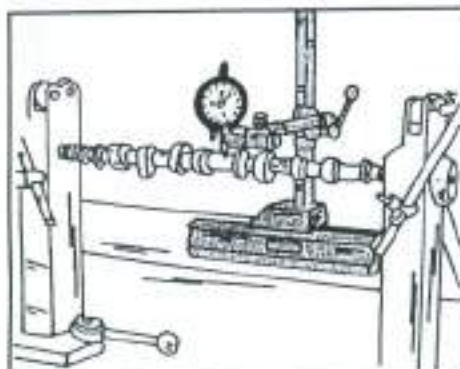

Fig. 1.23 - Checking a camshaft for run-out.

Camshaft: Place the camshaft with both end journals into V blocks or clamp the shaft between the centres of a lathe and apply a dial gauge to the centre journal, as shown in Fig. 1.23. Slowly rotate the shaft to check for exceeds 0.01 mm, fit a new shaft. The following points must be observed when replacing the camshaft:

run-out. If the dial gauge reading

exceeds 0.01 mm, fit a new shaft. Make sure to fit the correct shaft if the shaft is to be replaced. Check the identification number when ordering a new shaft.

Replacing Valve Stem Oil Seals (Cylinder Head fitted): Valve stem oil seals are available in repair kits. Included in the repair kits are protective sleeves which must be pushed over the valves during installation of the seals. Valve stem seals are different in diameter and can also be identified by their shape (Fig. 1.24).

Normally a special tool is used to fit the seals, but a well fitting piece of tube of suitable diameter can be used. Take care not to damage the sealing lip and the spring.

The valve cotter halves and the valve springs must be removed to replace the seals.

To prevent the valves from dropping into the combustion chambers, the pistons must

be at the top dead centre position. This is easy in the case of a four-cylinder engine, as two pistons are always at top dead centre. The operation is more difficult on a five-cylinder engine, as the crankshaft must be rotated by a certain angle to move the next piston to TD.C. Only attempt this operation if you are competent. Start by setting the piston of the No. 1 cylinder to the top dead centre position. Valve stems seals of cylinders Nos. 1 and 4 can be replaced in this position.

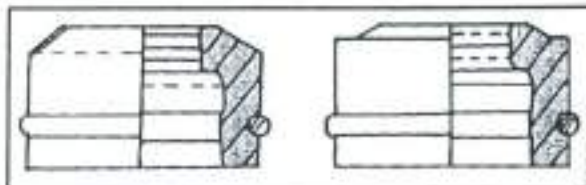

Fig. 1.24 - Sectional view of the valve stem oil seals. On the left for the exhaust valves; on the right for the inlet valves.

- Remove the camshaft (see description later on).
- Remove the valve cotter halves of the first cylinder as described in Section 1.3.0.2. Remove the valve springs in the case of a four-cylinder engine.
- Use a pair of pliers or a screwdriver to remove the valve stem seals, without damaging the valve stems.
- Coat the new seals with engine oil and carefully push them over the valve stems. The protective sleeve must be used for the inlet valves. Push the seals over the valve guides until properly in position.
- Fit the valve springs with the point spot towards the bottom, fit the upper spring cup and compress the springs until the valve cotter halves can be inserted. Make absolutely sure that the cotter halves have properly engaged before the crankshaft is rotated.
- Replace the valve stem seals of cylinder No. 4 in the same manner.
- Lift the camshaft sprocket slightly to prevent disengagement of the timing chain and rotate the crankshaft of a four-cylinder engine by half a turn. The valve stem seals of cylinders Nos. 2 and 3 can be replaced in the same manner. In the case of a five-cylinder engine, rotate the crankshaft until both valves of the next cylinder are closed. This will be in the order 2-4-5-3. As already mentioned, take care when rotating the crankshaft. Both valves of a cylinder must be at the same height, before the valve cotter halves are removed.
- Refit the camshaft and associated parts.

Note: Operate the valve spring compressor very slowly, as valve cotter halves sometimes stick to the valve stems. Observe the valve spring during compression. Only the spring should move, not the valve. Prevent by all means that the valve can press against the piston.

1.3.0.4. Cylinder Head - Assembly

The assembly of the cylinder head is a reversal of the dismantling procedure. Note the following points:

- Lubricate the valve stems with engine oil and insert the valves into the correct valve guides.

- Valve stem seals are different for inlet and exhaust valves. Make sure to order the correct seals. The repair kit contains fitting sleeves and these must be used to fit the seals (see last Section).
- The sleeves are fitted over the valve stem before the seal is pushed in position
- Fit the valve spring and valve spring collar over the valve and use the valve lifter to compress the spring. Insert the valve cotter halves and release the valve spring lifter. Make sure that the cotter halves are in position by lapping the end of the valve stem with a plastic mallet. Place a rag over the valve end - just in case.
- Fit the camshaft as described later on and carry out all other operations in reverse order to the dismantling procedure.

1.3.0.6. Hydraulic Valve Clearance Compensation

The function of the hydraulic valve clearance compensating elements is to eliminate valve clearance, i.e. the dimensional changes in the valve train (valve lash) due to heat expansion and wear are compensated by the elements. The rocker arm is in

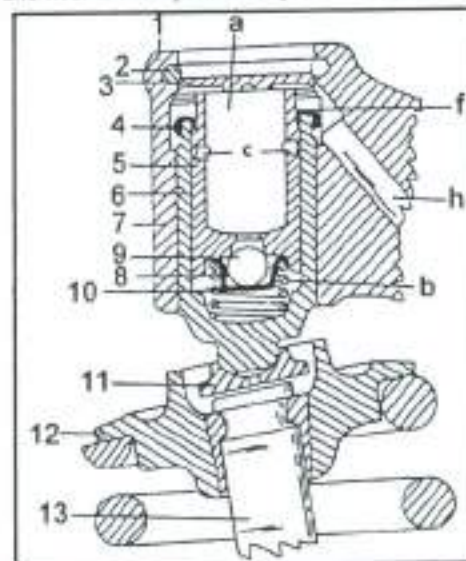

Fig. 1.25 - Sectional view of a valve clearance compensating element

- | | | |
|----------------|--------------------------|----------------|
| 1 Rocker lever | 7 Ball guide | 13 Valve |
| 2 Lock ring | 8 Thrust spring | a Oil chamber |
| 3 Washer | 9 Ball, 4 mm | b Work chamber |
| 4 Closing cap | 10 Thrust spring | c Return bores |
| 5 Thrust pin | 11 Ball socket | f Ring groove |
| 6 Guide sleeve | 12 Valve spring retainer | h Oil bores |

constant contact with the cam. The compensating elements cannot be repaired, but can be checked for correct functioning as described below. Figs. 1.25 and 1.26 show sectional views of a valve with clearance compensation. We will give a short description of the operation. All references refer to Fig. 1.25.

The hydraulic valve compensating element are fitted into the rocker levers and operate the valves directly via a ball socket (11). Each element consists of the following components:

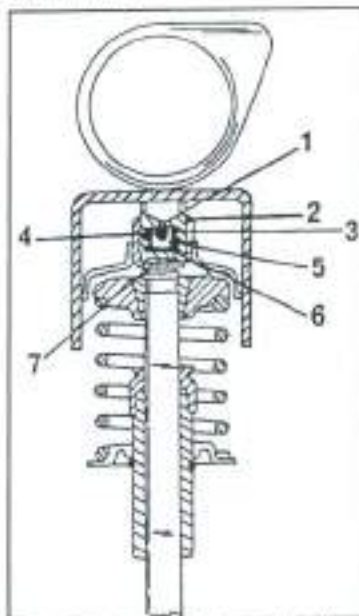

Fig. 1.26 - Sectional view of a valve and a compensating element,

- 1 Thrust pin
- 2 Lock ring
- 3 Thrust spring
- 4 Ball guide
- 5 Ball
- 6 Thrust spring

- The thrust pin (5) with oil supply chamber and the return bores and the ball valve (check valve), i.e. items (9), (7) and (10). The ball valve separates the supply chamber from the work chamber.

- The guide sleeve (6) with the work chamber (b), the thrust spring (8) and the closing cap (4).

When the engine is stopped and the tappet is held under load from the cam, the element can completely retract. The oil displaced from the work chamber (b) flows through an annular gap, i.e. the clearance between the guide sleeve and the thrust pin to the oil supply chamber (a).

When the cam lobe has moved past the valve tappet, the thrust pin (5) will be without load.

The thrust spring (6) forces the thrust pin upwards until the valve tappet rests against the cam.

The vacuum resulting from the upward movement of the thrust pin in the work chamber (b) opens the ball valve and the oil can flow from the supply chamber (h) into the work chamber (b). The ball valve closes when the valve tappet presses against the cam and puts the thrust pin under load. The oil in the work chamber acts as a "hydraulic rigid connection" and opens the valve in question.

When the engine is running and depending on the engine speed and the cam position, the thrust pin is only pushed down slightly.

The oil contained in the oil supply chamber (a) is sufficient to fill the work chamber (b) under all operating conditions of the engine. Oil or leak oil which is not required, as well as air are able to escape via the annular gap between the washer (3) and the rocker lever. The oil ejected from the work chamber flows via the annular gap between the guide sleeve and the thrust pin and the two return bores (c) into the oil supply chamber.

If the tappets are removed, note the following points:

- Always keep the tappets in an upright position, i.e. the open side towards the top.
- After removal of a tappet (see below), mark the cylinder number and the compensating element in suitable manner. Always fit original parts in their same locations.

Checking a hydraulic compensating element: As the elements are in continuous contact with the camshaft, you will rarely hear noises from the area of the hydraulic elements. If noises can be heard, check the elements as follows:

- Start the engine and run it approx. 5 minutes at 3000 rpm.
- Remove the cylinder head cover.
- Rotate the crankshaft until the cam for the tappet to be checked is pointing vertically towards the top.

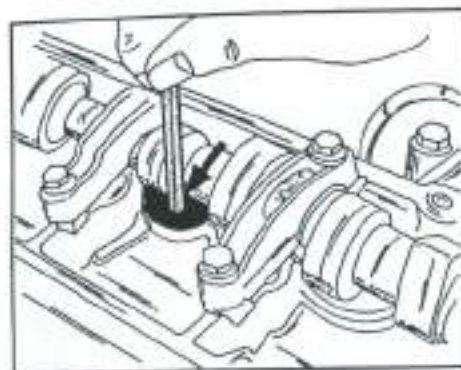

Fig. 1.27 - Checking of a hydraulic compensating element.

- Use a drift, as shown in Fig. 1.27 and push the tappet towards the inside, or try to move the tappet with the fingers.

- If the tappet cannot be depressed or excessive clearance can be felt between the tappet and the back of the cam, replace the tappet. The tappet is supplied together with the hydraulic compensating element. Mercedes workshops can reset the tappet to its original position, but this

operation is beyond the scope of the home mechanic.

Tappet Removal and Installation:

- Remove the camshaft as described later on.
- Use a suction tool to remove the tappets. Mark them, if they are to be refitted.
- Fit the tappets into their original bores, if re-used. Refit the camshaft as described and carry out all other operations in reverse order to the removal procedure.

1.3.1. PISTON AND CONNECTING RODS

1.3.1.0. Technical Data

All dimensions are given in metric units.

Pistons - 601 and 602 Engines

Piston Diameter - Std.:

Class A:	88.970 - 88.976 mm
Class X:	More than 88.975 - 88.983 mm
Class B:	More than 88.982 - 88.988 mm

Piston Running Clearance:

- New	0.017 - 0.043 mm
- Wear limit	0.12 mm

Max. weight difference within engine:

- New	4 grams
- Wear limit	10 grams

Piston Pins:

Pin diameter	26.995 - 27.000 mm
Piston pin running clearance:	

- In small end bush	0.018 - 0.029 mm
- In piston	0.004 - 0.015 mm

Piston Rings:

Piston Ring Gaps:	
- Upper rings	0.20 - 0.40 mm
- Wear limit	1.5 mm
- Centre rings	0.30 - 0.40 mm
- Wear limit	1.0 mm
- Lower rings	0.20 - 0.40 mm
- Wear limit	1.0 mm

Side Clearance in Grooves:

- Upper rings	0.090 - 0.120 mm
- Wear limit	0.20 mm
- Centre rings	0.050 - 0.080 mm
- Wear limit	0.15 mm
- Lower rings	0.030 - 0.065 mm
- Wear limit	0.10 mm

Connecting Rods

Distance from centre small end bore to centre big end bore	145.0 mm
Width of con rod at big end bore	24.000 mm
Basic bore diameter of big end bore	47.95 mm
Basic bore diameter of small end bore	29.500 mm

Small End Bush:

- Outer diameter	29.50 mm
- Inner diameter	27.000 mm
Max. twist of connecting rods	0.10 mm per 100 mm
Max. bend of connecting rods	0.045 mm per 100 mm
Max. weight difference in same engine	5 gram (per set)

Connecting Rod Bolts:

- Thread	M9 x 1
- Diameter of stretch neck	7.4 mm
- Min. diameter of stretch neck	7.1 mm
Connecting rod bearing details:	See under "Crankshaft"

Pistons - 616 Engine

Piston Diameter - Std. - Piston No. 03, 38:	
Class 0	90.98 mm
Class 1	90.99 mm
Class 2	91.00 mm

Piston Diameter - Std. - Piston No. 35, 44:

Class 0	90.88 mm
Class 1	90.89 mm
Class 2	90.90 mm

Piston Running Clearance:

- New	0.02 - 0.03 mm
- Wear limit	0.12 mm

Max. weight difference within engine:

- New	4 grams
- Wear limit	10 grams

Piston Pins:

Pin diameter	25.995 - 26.000 mm
Piston pin running clearance:	
- In small end bush	0.012 - 0.023 mm
- In piston	0.000 - 0.010 mm

Piston Rings:

Piston Ring Gaps:	
- Upper rings	0.30 - 0.45 mm
- Wear limit	1.5 mm
- Centre rings	0.30 - 0.45 mm
- Wear limit	1.0 mm
- Lower rings	0.25 - 0.40 mm
- Wear limit	1.0 mm

Side Clearance in Grooves:

- Upper rings	0.10 - 0.12 mm
- Wear limit	0.20 mm
- Centre rings	0.08 - 0.11 mm
- Wear limit	0.15 mm
- Lower rings	0.020 - 0.05 mm
- Wear limit	0.10 mm

Connecting Rods

Distance from centre small end bore to centre big end bore	149.05 mm
Basic bore diameter of big end bore	55.60 - 55.62 mm
Basic bore diameter of small end bore	29.000 - 29.02 mm

Small End Bush:

- Outer diameter	29.096 - 29.058 mm
- Inner diameter	26.012 - 26.018 mm
Max. twist of connecting rods	0.10 mm per 100 mm
Max. bend of connecting rods	0.045 mm per 100 mm
Max. weight difference in same engine	5 gram (per set)

Connecting Rod Bolts:

- Thread	M10 x 1
- Diameter of stretch neck	8.4 mm
- Min. diameter of stretch neck	8.0 mm

Connecting rod bearing details:

See under "Crankshaft"

1.3.1.1. Piston and Connecting Rods - Removal

The pistons are made of light-alloy. Each piston has a star-shaped cavity, a pre-combustion chamber and two round recesses for the valve heads. The exit of the pre-combustion chamber is connected with the combustion cavity. Fig. 1.28 shows a view of the piston.



Fig. 1.28 - View of the piston, showing the combustion chamber with (1). The two recesses for the valves prevent contact between the valve heads and the piston crown.

Three piston rings are fitted to each piston. The two upper rings are the compression rings, i.e. they prevent the pressure above the piston crown to return to the crankcase. The lower ring is the oil scraper ring. Its function is to remove excessive oil from the cylinder bore, thereby preventing the entry of oil into the combustion chamber. The three rings are not the same in shape. The upper ring has a rectangular section, the centre ring has a chamfer on the inside and the lower ring is chrome-plated on its outside. Only the correct

filing of the piston rings will assure the proper operation of the piston sealing.

Pistons and connecting rods are pushed out towards the top of the cylinder bores, using a hammer handle after connecting rod bearing caps and shells have been removed. Before removal of the assemblies note the following points:

- Pistons and cylinder bores are graded in three diameter classes within specified tolerance groups and marked with the letters A, X and B or O, 1 and 2 (616 engine). The class number is stamped into the upper face of the cylinder block, next to the particular cylinder bore, as shown in Fig. 1.29.

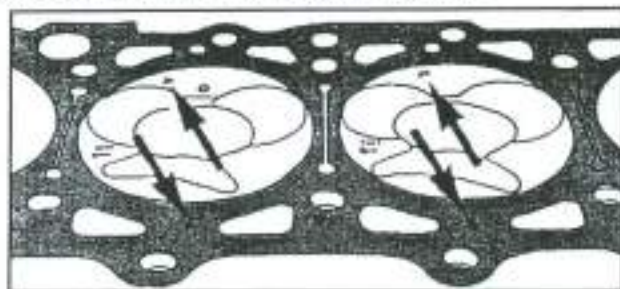

Fig. 1.29 - Identification (marking) of piston crown and cylinder block face with the group code letters.

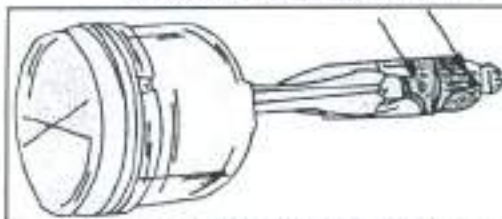

Fig. 1.30 - Connecting rods and bearing caps can be marked with a centre punch as shown.

- The class number of the piston must always be identical with the letter stamped next to the cylinder bore. Piston diameter, the class number and the two last numbers of the piston

spare part number are stamped into the piston crown. An arrow with the inscription "Vorn" (front), indicating the fitting direction is also stamped into the piston crown.

- For repairs, only pistons with group code letter "X" are available. These pistons can also be used if the code letters "A" or "B" are stamped into the cylinder block.

If the cylinder bores are re-bored, their size will be increased to take the group "X" pistons, plus the allowance for the piston running clearance.

- Mark each piston and the connecting rod before removal with the cylinder number. This can be carried out by writing the cylinder number with paint onto the piston crown. Also mark an arrow, facing towards the front of the engine (the arrow in the piston crown will be covered by the carbon deposits). When removing the connecting rod, note the correct installation of the big end bearing cap. Immediately after removal mark the connecting rod and the big end bearing cap on the same side. This is best done with a centre punch (cylinder No. 1 one punch mark, etc., see Fig. 1.30).
- Mark the big end bearing shells with the cylinder number. The upper shells have an oil drilling (to lubricate the piston pin).
- The big end bearing shells can be of two different diameters. At the lower end of the connecting rod bearing cap, at the position shown in Fig. 1.31, you will see one or two punch marks. If one punch mark is present, bearing caps with a blue paint mark (on the edge of the bearing shells) are fitted. If two punch marks are visible, as shown in the illustration, bearing shells without colour code are used.

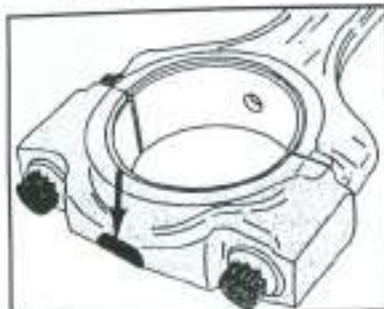

Fig. 1.31 - The connecting rods are marked at the position shown to indicate the bearing shell diameter.

- Big end bearing journals can be re-ground to four undersizes (in steps of 0.25 mm between sizes). Corresponding bearing shells are available.

- Remove the bearing caps and the shells and push the assemblies out of the cylinder bore. Any carbon deposits on the upper edge of the bores can be carefully removed with a scraper.

Fig. 1.32 - Removal of the securing clip for the piston pins. Apply the screwdriver blade at the ring gap.

- Remove the piston pin snap rings. A notch in the piston pin bore enables a pointed drift to be inserted, as shown in Fig. 1.32, to remove the rings. Press the piston pins out of the pistons. If necessary heat the piston in boiling water.
- Remove the piston rings one after the other from the pistons, using a piston ring pliers if possible (Fig. 1.33). If the rings are to be re-used, mark them in accordance with their pistons and position.

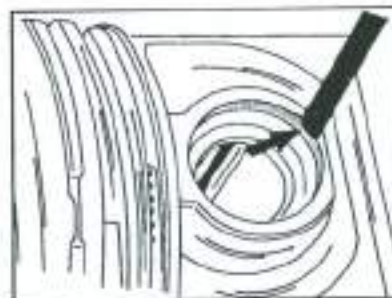

1.3.1.2. Measuring the Cylinder Bores

An inside caliper is necessary to measure the diameter of the cylinder bores. The following operations are not possible if none is available or cannot be hired.

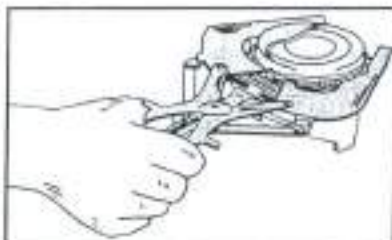

Fig. 1.33 - Removal or installation of piston rings with a pair of piston ring pliers. Never expand rings more than necessary to prevent breakage.

Cylinder bores must be measured in longitudinal and transverse direction and at three positions down the bore, i.e. 10 mm (0.4 in.) from the upper bore edge, 10 mm from the lower bore edge and once in the centre, totalling 6 measurements. The worst measurement must be taken when deciding on the size for the pistons to be fitted (Fig. 1.34).

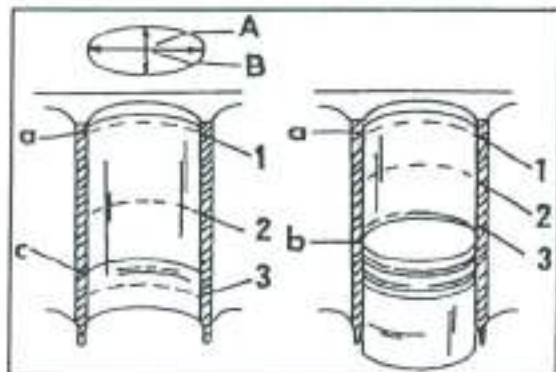

Fig. 1.34 - Measuring diagram for the cylinder bores. Numbers 1, 2 and 3 indicate the three levels where measurements should take place.

- | | |
|---|--|
| A = Measurement parallel to bore | b = Bottom dead centre of piston |
| B = Measurement across bore. | o = Lower return point of oil control ring |
| a = Upper return point of upper piston ring | 1-3 = Measuring points |

Note that all cylinder bores must be re-bored, even if only one of the bores is outside the diameter limit. A tolerance of 0.20 mm is permissible. If the wear is outside the limits, it is possible to have new cylinder liners fitted to the block. Your dealer will advise you what can be done.

The final cylinder bore diameter is determined after measuring the piston diameter. To measure the diameter, apply an outside micrometer 10 mm (0.4 in.) from the bottom edge and at right angle to the piston pin bore. Add the piston running clearance to this dimension and 0.03 mm for the honing of the cylinders. The piston running clearance must not exceed 0.12 mm.

To measure the running clearance, determine the piston and cylinder bore diameters as described above and calculate the difference between the dimensions.

If the difference is more than 0.12 mm, have the cylinder bores re-bored to fit oversize pistons.

1.3.1.3. Checking Pistons and Connecting Rods

All parts should be thoroughly inspected. Signs of seizure, grooves or excessive wear require the part to be replaced. Check the pistons and connecting rods as follows:

- Check the side clearance of each piston ring in its groove by inserting the ring together with a feeler gauge, as shown in Fig. 1.35. The grooves must be thoroughly cleaned before the check. If the wear limit exceed the values in the technical data is reached, either the rings or the piston are worn.

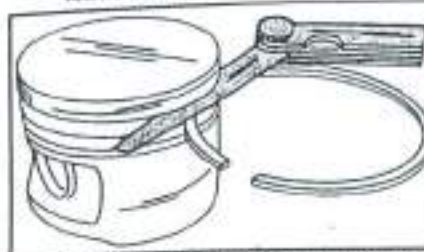

Fig. 1.35 - Checking the side clearance of piston rings.

- Check the piston ring gap by inserting the ring from the bottom into the cylinder bore. Use a piston and carefully push the piston ring approx. 1 in. further into the bore. This will square it up. Insert a feeler gauge between the two piston ring ends to check the ring gap, as shown in Fig. 1.36. Refer to Section 1.3.1.0. for

the wear limits. Rings must be replaced, if these are exceeded. New rings should also be checked in the manner described.

Fig. 1.36 - Checking piston ring gaps.

- Piston pins and small end bushes must be checked for wear or seizure. One individual connecting rod can be replaced, provided that a rod of the same weight group is fitted. Connecting rods are marked with either one or two punch marks (arrow, Fig. 1.30) and only a rod with the same mark must be fitted.

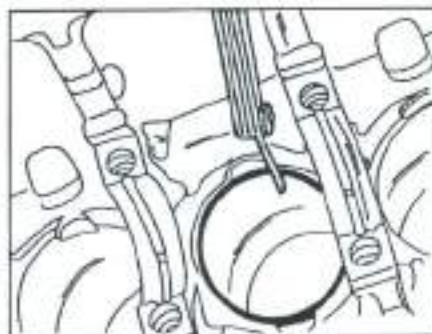

Before re-using the connecting rod bolts check their diameter at the position shown in Fig. 1.37, if this is smaller than given for the engine in question, replace the bolt. A second check is carried out by placing the connecting rod bearing on one of the connecting rod bolts. If the bearing cap is moving under its own weight, renew bolt.

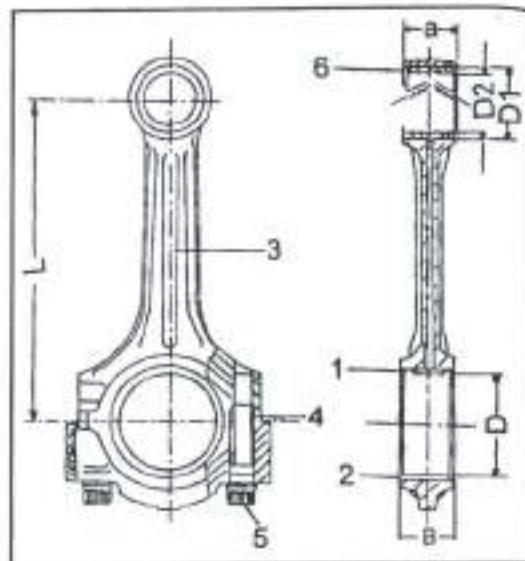

Fig. 1.37 - Connecting rod bolts can stretch in their length "L". By measuring the stretch neck "c", you will know if the bolts can be re-used.

- Connecting rods should be checked for bend or twist, particularly when the engine has covered a high mileage. A special jig is necessary for this operation and the job should be carried out by an engine shop. The max. values are given in Section 1.3.1.0.

Fig. 1.38 - Sectional view of a connecting rod (601 and 602 engines)

- 1 Upper bearing shell
- 2 Lower bearing shell
- 3 Connecting rod
- 4 Spring pins (roll pins)
- 5 Connecting rod bolt
- 6 Small end bush
- L 145.0 mm
- B 24.00 mm
- D 47.95 mm
- D1 29.50 mm
- D2 27.00 mm or 28.00 mm



The following information concern the connecting rods:

- Connecting rods which were over-heated due to bearing failure (bluefish colour) must not be refitted.
- Connecting and bearing caps are matched to each other and must be fitted accordingly.
- New connecting rods are supplied together with the small end bearing bush and can be fitted as supplied.
- Fit the bearing cap with the inserted bearing shells and clamp the connecting rod into a vice. Tighten the bolts to the specified torque, using an internal micrometer, measure the big end bore diameter at various points. If the value of 51.119 mm is exceeded, or the bore is out of round, replace the complete connecting rod.
- If the piston pin has excessive clearance in the small end bush, fit a new bush. When pressing in the new bush, align the oil bore in the bush with the oil bore in the connecting rod. The small end bush must be reamed to the diameter "D2" in Fig. 1.38 to obtain the correct piston pin running clearance and again we recommend to have the job carried out by an engine shop.

1.3.1.4. Checking the Big End Bearing Clearance

These operations are described in connection with the crankshaft (Section 13.3.2.).

1.3.1.5. Piston and Connecting Rods - Assembly

If new pistons are fitted, check the piston crown markings to ensure the correct pistons are fitted. If the original pistons are fitted, arrange them in accordance with the cylinder number markings.

- If connecting rods have been replaced check the bottom of the big end bearing caps. Either one or two punch marks are stamped into the centre of the cap, as shown in Fig. 1.31. These numbers refer to the bearing shells to be fitted. Shells with blue colour code (marked at the side of the shells) must be fitted if one punch mark is stamped into the cap.
- Insert the connecting rod into the piston and align the two bores. Make sure that the arrow in the piston crown and locating lugs for the bearing shell location are facing the L.H. side of the engine, as shown in Fig. 1.39.

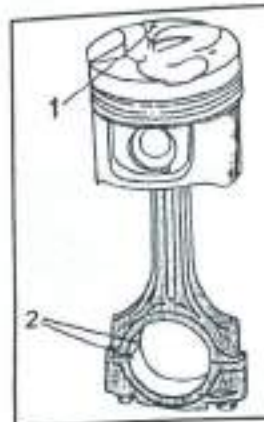

Fig. 1.39 - The arrow in the piston crown (1) must face the front end of the engine when the locating lugs for the bearing shells (2) are on the L.H. side of the cylinder block.

• Generously lubricate the piston pin with engine oil and insert it into the piston and connecting rod, using thumb pressure only. Never heat the piston to fit the piston pin. Fit the circlips to both sides of the piston, making sure of their engagement around the groove. Move the piston up and down to check for free movement.

• Using a pair of piston ring pliers, fit the piston rings from the top of the piston, starting with the bottom ring. The two compression rings could be mixed up and Figs. 1.40 should be referred to avoid mistakes. Under no circumstances mix-up the upper and lower compression rings.

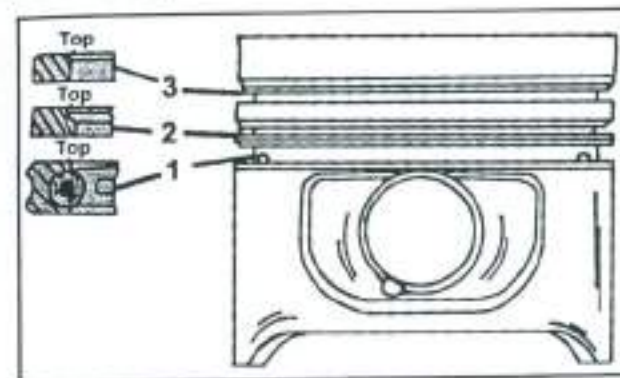

Fig. 1.40 - Sectional of a piston, concentrating on the piston rings.
 1 Slotted control ring with expander ring, chrome plated
 2 Chamfered compression ring
 3 Square compression ring, contact face asymmetrically ground and chrome-plated

Modifications - Pistons and Connecting Rods

Modified pistons and connecting rods have been fitted to 601 engines with the introduction of model year 1985. The width of the connecting rods has been reduced from 24 mm to 22 mm. At the same time the piston pin diameter ("D2" in Fig. 1.38) has been reduced from 27 to 26 mm and is 1.0 mm longer. The new connecting rods can be fitted to earlier engines, but only together with the new pistons and piston pins. It is obvious that the new pistons can only be fitted together with the modified connecting rods.

If the engine operates with an EGR system, the pistons are cooled by oil splash jets (if applicable, introduced for model year 1991 on 601/602 engines).

1.3.1.6. Pistons and Connecting Rods - Installation

Generously lubricate the cylinder bores with oil. Markings on connecting rods and bearing caps must be opposite each other. The arrows in the piston crowns must face towards the front of the engine.

Arrange the piston rings at equal spacings of 120° around the circumference of the piston skirt and use a piston ring compressor to push the rings into their grooves. Check that all rings are fully pushed in.

Insert the second bearing shell into the connecting rod bearing cap, with the locating tab on the L.H. side and fit the assembly over the connecting rod. Check that connecting rod/cap marks are facing each other.

Coat the contact areas for the cap bolts with engine oil and fit and tighten the bolts to 3.0 kgm (22 ft.lb.) in several stages. From this position tighten each bolt by a further 90 - 100° (approx. 1/4 of a turn) without using the torque wrench. It is assumed that the stretch bolts have been measured as previously described.

Rotate the crankshaft until the two remaining crankpins are at bottom dead centre and fit the two other piston/connecting rod assemblies in the same manner.

Check the pistons and connecting rods once more for correct installation and that each piston is fitted to its original bore, if the same parts are refitted.

With a feeler gauge measure the side clearance of each big end bearing cap on the crankpin. The wear limit is 0.50 mm.

1.3.2. CYLINDER BLOCK

1.3.2.0. Technical Data

Cylinder Bore Diameter (601/602 engines):

Nominal diameter - Group A:	89.000 - 89.006 mm
- Group X:	More than 89.006 - 89.012 mm
- Group B:	more than 89.012 - 89.018 mm

Max. wear, longitudinal and across: 0.10 mm (0.004 in.)

Max. out-of-round or taper of bores:

New condition:	0.014 mm
Wear limit:	0.05 mm

Measuring point for bores: Upper edge, centre and lower edge, in longitudinal and transverse direction

Cylinder Bore Diameter (616 engine) - Version 1:

Nominal diameter - Group 0 - Cylinder No. 1:	91.009 - 91.018 mm
- Group 1:	91.019 - 91.028 mm
- Group 2:	91.029 - 91.038 mm
Nominal diameter - Group 0 - Cylinder No. 2 to 4:	90.998 - 91.008 mm
- Group 1:	91.009 - 91.018 mm
- Group 2:	91.019 - 91.028 mm

Cylinder Bore Diameter (616 engine) - Version 2:

Nominal diameter - Group 0 - Cylinder No. 1:	90.906 - 90.918 mm
- Group 1:	90.918 - 90.928 mm
- Group 2:	91.029 - 91.038 mm
Nominal diameter - Group 0 - Cylinder No. 2 to 4:	90.898 - 90.908 mm
- Group 1:	90.909 - 90.918 mm
- Group 2:	90.918 - 90.928 mm

Note: Repair sizes are not available for this engine, as cylinder liners are supplied with nominal diameter.

Max. wear, longitudinal and across: 0.10 mm (0.004 in.)

Max. out-of-round or taper of bores:

New condition:	0.013 mm
Wear limit:	0.05 mm
Measuring point for bores:	As for other engines

Crankcase

Permissible unevenness of:

Upper crankcase face:	0.10 mm
Lower crankcase face:	0.05 mm
Difference between upper and lower sealing face:	0.10 mm (0.004 in.)

1.3.2.1. Servicing

Special attention should be given to the cylinderblock each time the crankshaft has been removed, irrespective whether the bores are to be re-machined or not.

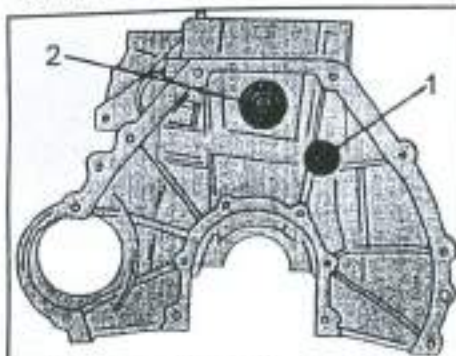

Fig. 1.41 - View of the rear end of the cylinder block, showing the steel ball (1) for the main oil gallery and the wals plug (2).

Thoroughly clean all cavities and passages and remove all traces of foreign matter from the joint faces. If any machining or honing of the bores takes place, it is essential that all swarf is removed before assembly of the engine takes place. The main oil gallery is closed off steel balls of 17 mm diameter at the front and 15 mm diameter at the rear. The steel balls

must be removed in order to clean the main oil gallery. The steel balls can be refitted unless they show deep grooves. Figs. 1.41 and 1.42 show where these steel balls are located. Fig. 1.42 also shows other parts of the cylinder block of a four-cylinder engine, which should also be checked for wear. A five-cylinder engine is similar. We must point out that the special drift 601 589 06 15 00 is used to drive the steel balls in position to ensure their correct sealing. If possible always clean oil galleries with compressed air.

The following instructions apply to the advanced engineer:

If oil leaks can be detected at the front or rear of the cylinder block and the mentioned special drift cannot be obtained, it will be possible to close off the bores with threaded plugs. At the front an M18 x 15 mm plug (Part No. 000906 0 18 000), at the rear an M16 x 15 mm plug (Part No. 000906 0 16 002) is used. Corresponding threads must be cut into the cylinder block. The thread depth at the front is 10 mm, at the rear 14 mm. Remove all metal chips and fit the plugs with "Loctite" thread locking agent before installation.

If the special drift can be obtained, replace the steel balls as follows (it is assumed that the engine is fitted):

- Remove the oil pump.
- Remove the transmission and the flywheel.
- Use a steel rod of 14 mm diameter and 550 mm in length and drive out the steel balls from the rear towards the front, as shown in Fig. 1.43. Thoroughly clean the main oil gallery.

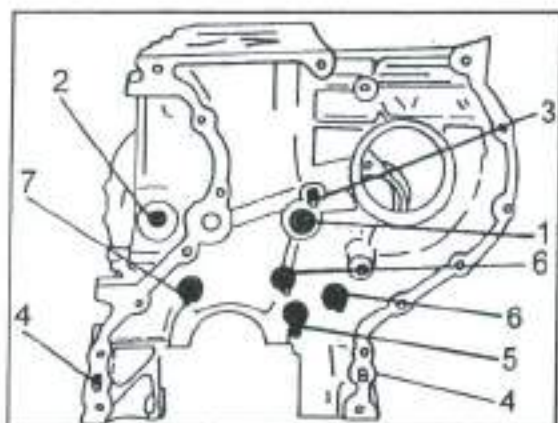

Fig. 1.42 - View of the front end of the cylinder block, showing the location of the various parts.

- | | |
|--------------------------|---|
| 1 Welsh plug | 5 Bearing pin, oil pump chain tensioner |
| 2 Steel ball, 17 mm dia. | 6 Bearing pin, tensioning rail |
| 3 Oil splash jet | 7 Bearing pin, slide rail |
| 4 Roll pin | |



Fig. 1.43 - Driving a steel ball out of the cylinder block.

- Coat the ball-shaped recess of the special drift with grease and insert the ball.
- Insert the steel ball into the corresponding bore and drive it into position to its stop. Fig. 1.44 shows this operation.
- Refit the oil pump and the flywheel, refit the transmission and run the engine. Check the area of the steel ball for leaks.

Fig. 1.44 - Fitting a steel ball to the cylinder block. The insert shows the shape of the special drift.

Measurement of the cylinder bores should be made in accordance with the data given in Section 1.3.2.0. and the instructions in Section 13.1.2. The difference between the upper and the lower measurements gives the taper; the difference between the longitudinal and transverse measurements gives the out-of-round.

Two oversize pistons are available for the 601 and 602 engine and the block must be re-bored to the next size.

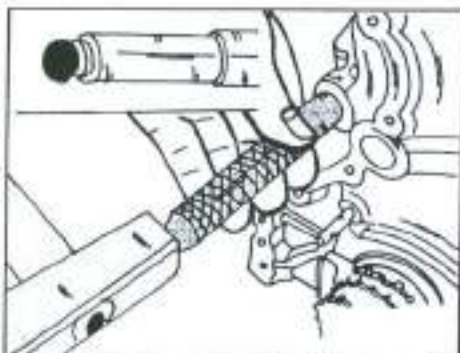

The cylinder block upper face and the crankcase lower face must be checked for distortion in a similar manner as described for the cylinder head. Section 13.2.0. gives the distortion values.

Replacing the Welsh Plugs: Welsh plugs are fitted into the side of the cylinder block. These plugs will be "pushed" out if the coolant has been allowed to freeze and can be replaced with the engine fitted, provided the special tool 102 589 07 15 00 can be obtained. On the side where the cylinder block drain plug is located you will find a plug of 34 mm diameter, on the opposite side, i.e. the side with the oil filter there are two more plugs with the same diameter. A further welsh plug of 17 mm diameter is fitted into the front end of the block (shown with "1" in Fig. 1.42). A plug of 34 mm diameter is also fitted to the rear end ("2", Fig. 1.41).

Welsh plugs can be replaced as follows:

- Drain the cooling system and remove all parts obstructing the welsh plug in question, i.e. transmission, intermediate flange, injection pump, etc.
- Place a small chisel or strong screwdriver blade below the lip of the welsh plug and drive the plug towards the inside until it has swivelled by 90°. Then grip the plug with a pair of pliers, as shown in Fig. 1.45 and remove it.

Fig. 1.45 - Removal of a welsh plug.

Thoroughly clean the opening in the cylinder head from grease and coat the locating bore with "Loctite 241". Fit the large new welsh plug with the special tool mentioned above. Drift No. 601 589 07 15 00 is required for the 17 mm plug.

- Refit all removed parts and allow the vehicle to stand for at least 45 minutes before the cooling system is filled and the engine is started. Then start the engine and check for coolant leaks.



Note: Replacement cylinder liners are available for the engine. Check with your dealer before considering replacement of the cylinder block.

Cylinder Block (crankcase) Modifications

The crankshaft bearing bores of the 601 and 602 engines were reduced by 2 mm with the introduction of model year 1985. The main bearing cap bolts were reduced from M12 to M11 at the same time. The bolts are stretch bolts and must be less than 63.6 mm in length if they are to be re-used. The upper surface of the cylinder block has also been modified and must only be used together with the modified cylinder head. The coolant drain plug in the cylinder block has an M18 thread (earlier blocks with M14 thread).

If an EGR system is fitted, you will find oil feed bores and oil cooling jets for the pistons. The jets are fitted at the position shown in Fig. 1.46. These cylinder blocks cannot be fitted to other models. Always seek advice from your Mercedes Dealer, if you are intending to fit a replacement cylinder block.



Fig. 1.46 - The arrow shows the oil splash jet (engine with EGR system).

1.3.3. CRANKSHAFT AND BEARINGS

1.3.3.0. Technical Data

All dimensions in metric units.

Machining tolerances:

Max. out-of-round of journals:	0.005 mm
Max. taper of main journals:	0.010 mm
Max. taper of crankpins:	0.015 mm
Max. run-out of main journals*:	
Journals Nos. II and IV	0.07 mm
Journal No. III:	0.10 mm

* Crankshaft placed with Nos. I and V journals (601) or I and IV journals (602) in "V" blocks.

Main Bearing Journal Diameter - 601/602 engine:	
Nominal:	57.950 - 57.965 mm
1st repair size:	57.700 - 57.715 mm
2nd repair size:	57.450 - 57.465 mm
3rd repair size:	57.200 - 57.215 mm
4th repair size:	56.950 - 56.965 mm

Basic Bearing Bores (only 601/602 engine given):	
For main bearings:	62.500 - 62.519 mm
For big end bearings:	51.600 - 51.619 mm

Main Bearing Journal Diameter - 616 engine:	
Nominal:	69.96 - 69.95 mm
1st repair size:	69.71 - 69.70 mm
2nd repair size:	69.46 - 69.45 mm
3rd repair size:	69.21 - 69.20 mm
4th repair size:	68.96 - 68.95 mm

Width of Journal on fitted Bearing:	
Nominal dimension:	34.00 - 34.4 mm (with thrust washers)

Repair size:	34.00 - 34.02 mm (with flanged bearings) to 34.53 mm (with thrust washers) to 34.50 mm (with flanged bearings)
--------------	--

Crankpin Diameter - 601/602 engines:	
Nominal dimension:	47.950 - 47.965 mm
1st repair size:	47.700 - 47.715 mm
2nd repair size:	47.450 - 47.560 mm
3rd repair size:	47.200 - 47.215 mm
4th repair size:	46.950 - 46.965 mm
Width of Crankpins:	
Nominal Dimension:	27.960 - 28.044 mm
Repair sizes:	Up to 28.30 mm

Crankpin Diameter - 616 engine:	
Nominal dimension:	51.95 - 51.96 mm
1st repair size:	51.70 - 51.71 mm
2nd repair size:	51.45 - 51.46 mm
3rd repair size:	51.20 - 51.21 mm
4th repair size:	50.95 - 50.96 mm

Width of Crankpins:	
Nominal Dimension:	32.00 - 31.10 mm
Repair sizes:	Up to 32.20 mm

Bearing Running Clearances (all engines):	
Main bearings:	0.03 - 0.07 mm (best 0.055 mm)
Big end bearings:	0.03 - 0.07 mm (best 0.50 mm)
Wear limit:	0.080 mm
Bearing End Float (all engines):	
Main bearings:	0.10 - 0.25 mm
Big end bearings:	0.12 - 0.26 mm
Wear limit - Main bearings:	0.30 mm
Wear limit - Big end bearings:	0.50 mm

Bearing Shells (all engines):		
	Main Bearings	Big End Bearings
Nominal Dimension:	2.25 mm	1.80 mm
1st repair size:	2.37 mm	1.92 mm
2nd repair size:	2.50 mm	2.05 mm
3rd repair size:	2.62 mm	2.17 mm
4th repair size:	2.75 mm	2.30 mm

Connecting Rod Bolts (601/602 engines):	
Thread:	M9 x 1
Diameter of stretch neck:	7.4 mm
Min. diameter of stretch neck:	7.1 mm
Tightening torque:	3.0 ± 0.5 kgm (22 ± 0.3 ft.lb.) + 90 - 100°
Connecting Rod Bolts (616 engine):	
Thread:	M10 x 1
Diameter of stretch neck:	8.4 mm
Min. diameter of stretch neck:	8.0 mm
Tightening torque:	4.0 - 5.0 kgm (28 - 36 ft.lb.) + 90 - 100°

1.3.3.1. Crankshaft - Removal and Installation

The engine must be removed to take out the crankshaft. The operations are similar on all engines.

- Remove the transmission from the engine. Take care not to distort the clutch shaft.
- Counterhold the flywheel in suitable manner and evenly slacken the clutch securing bolts. Use a centre punch and mark the clutch and flywheel at opposite points. Lift off the clutch plate and the driven plate. Immediately clean the inside of the flywheel and unscrew the flywheel.
- Remove the drive plate for a torque converter of an automatic transmission in the same manner.

Fig. 1.47 - Checking the crankshaft end float.

- With the flywheel still locked, remove the crankshaft pulley bolt and remove the crankshaft pulley/damper as described later on.
- Remove the cylinder head as described in Section 1.2.1. and the timing cover as described in Section 1.3.4. Remove the oil sump and oil pump.
- Remove the pistons and connecting rods as described in Section 1.3.1.

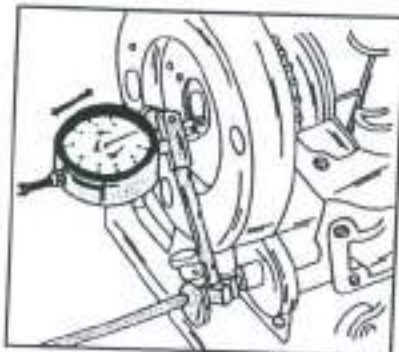

Fig. 1.48 - View of the cylinder block rear end, showing the attachment of the seal flange.

- 1 Roll pin
- 2 Oil seal flange
- 3 Screw, M6 x 22 mm
- 4 Crankshaft oil seal
- 5 Oil sump
- 6 Bolt, M6 x 85 mm
- 7 Crankshaft

• The crankshaft end float should be checked before the crankshaft is removed. To do this, place a dial gauge with a suitable holder in front of the cylinder block and place the

gauge stylus against the end flange of the crankshaft, as shown in Fig. 1.47. Use a screwdriver to push the crankshaft all the way to one end and set the gauge to "0". Push the shaft to the other side and note the dial gauge reading. The resulting value is the end float. If it exceeds 0.30 mm (0.012 in.) replace the thrust washers during assembly, but make sure to fit washers of the correct width (see Section 1.3.2.0). These are located left and right at the centre bearing. Note that only two washers of the same thickness must be fitted.

- Unscrew the oil seal flange from the rear of the cylinder block. Fig. 1.48 shows a view of the fitted oil seal flange.
- Unscrew the main bearing bolts evenly across. The bearings caps are marked with the numbers 1 to 5 or 1 to 6, depending on the engine. The numbers are

stamped into the centre of the caps, as shown in Fig. 1.49. No. 1 cap is located at the crankshaft pulley side.

Fig. 1.49 - The arrows show the numbering of the main bearing caps (four-cylinder). Caps must be fitted in their original order.

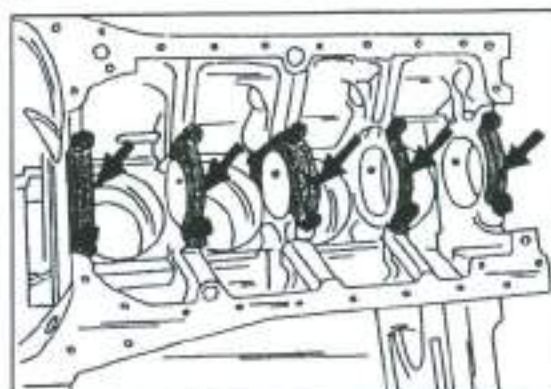

- Remove the bearing shells from the bearing journals (they could also stick to the caps) and immediately mark them on their back faces with the bearing number.
- Lift the crankshaft out of the cylinder block and remove the remaining thrust washers from the centre bearing location and the remaining bearings shells.
- Keep the shells together with the lower shells and the bearing caps. These shells have an oil bore and a groove and must always be fitted into the crankcase when the crankshaft is installed.

1.3.3.2. Inspection of Crankshaft and Bearings

Main and crankpin journals must be measured with precision instruments to find their diameters. All journals can be re-ground four times and the necessary bearing shells are available, i.e. undersize shells can be fitted.

Place the crankshaft with the two end journals into "V" blocks and apply a dial gauge to the centre main journal. Rotate the crankshaft by one turn and read off the dial gauge. If the reading exceeds 0.06 mm, replace the crankshaft.

Check the main bearing and big end bearing running clearance as follows:

- Bolt the main bearing caps without shells to the crankcase, oil the bolt threads and fit each cap. Tighten the bolts to 9.0 kgm (65 ft.lb.) if the engine has been manufactured before October 1984. From 1985, when bearing cap bolts with double hexagon and shoulder are used, tighten the bolts to 5.5 kgm (39.6 ft.lb.) and then angle-tighten them a further 90 - 100°. Bearing caps are offset and can only be fitted in one position.

Fig. 1.50 - Measuring the inside diameter of the fitted bearing shells.

- Referring to Fig. 1.50 measure the bearing bores in directions A, B and C and write down the results. If the basic diameter is exceeded (see Section 1.3.3.0), the bearing cap and/or the cylinder block must be replaced.
- Remove the bearing caps and refit them, this time with the well cleaned

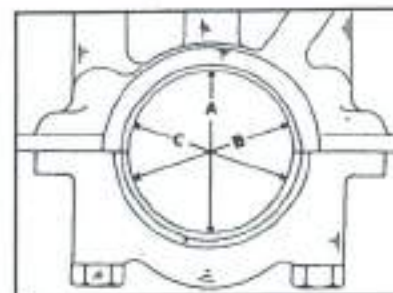

bearing shells. Re-tighten the bolts as specified.

- Measure the diameter of each bearing in accordance as shown in Fig. 1.50 and write down the results. Deduct the journal diameter from the bearing diameter. The resulting difference is the bearing running clearance, which should be between 0.031 - 0.073 mm, with a wear limit of 0.080 mm.
- Check the big end bearing clearances in a similar manner, but bolt the bearing caps to the connecting rods. Tighten the nuts to the value given in the technical data and angle-tighten as above. The bearing clearance should be between 0.031 - 0.073 mm, with the same wear limit.

Selection of bearing shells is rather complicated, and we advise you to take the cylinder block to an engine shop, if the above measurements have revealed that new bearing shells are necessary.



Fig. 1.51 - Correct fitting of the crankshaft thrust washers.

1.3.3.3. Crankshaft - Installation

Thoroughly clean the bearing bores in the crankcase and insert the shells with the drillings into the bearing bores, with the tabs engaging the notches. Fit the thrust washers to the centre bearing, with the oil grooves towards the outside, as shown in Fig. 1.51.

Use the two forefingers as shown in Fig. 1.52 to hold the thrust washers against the bearing cap and fit the cap in position.

Fig. 1.52 - Fitting the main bearing cap together with the thrust washer.

Lift the crankshaft in position and fit the bearing caps with the inserted shells (again shells well oiled and locating tabs in notches). Fit the two thrust washers to the centre bearing cap, again with the oil groove towards the outside. Place this cap in position, guiding the two thrust washers in order not to dislodge them. Use the forefingers to hold the washers as shown in Fig. 1.52. Note that the thrust washers have been changed. Quote the engine number when new washers are ordered.



Check the numbering of the bearing caps and fit the well oiled bolts. Tighten the bolts from the centre towards the outside in several steps to a torque reading of 9.0 kgm (65 ft.lb.) if bolts with hexagonal heads are used. If the bolts have a double-hexagonal head and a shoulder, tighten them to 5.5 kgm (39.5 ft.lb.) and from this position a further 90 - 100°.

Rotate the crankshaft a few times to check for binding (hard spots).

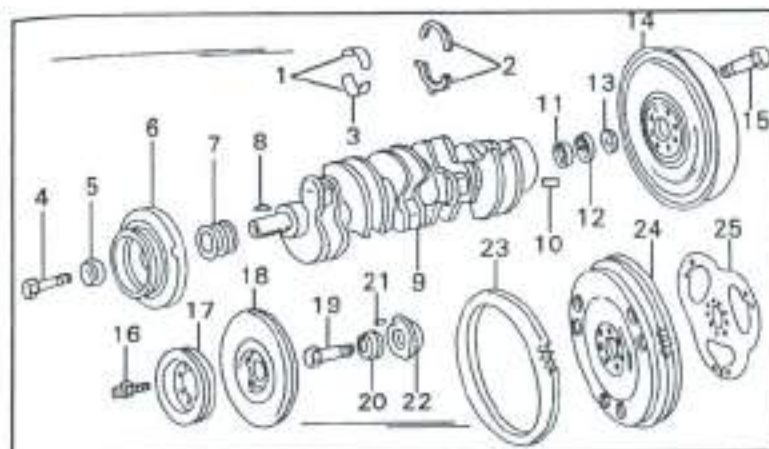
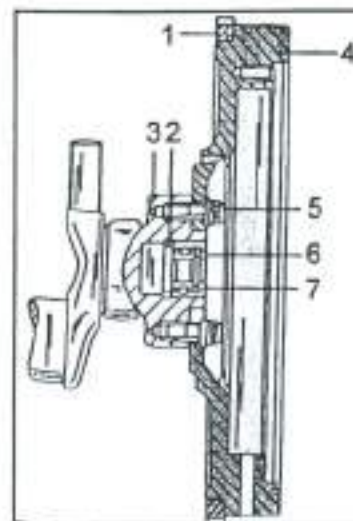

Fig. 1.53 - Exploded view of the crankshaft.

1 Main bearing shells	10 Dowel pin	19 Bolt, damper hub
2 Thrust washer halves	11 Spacer ring	20 Plain washer
3 Lower bearing shell	12 Ball bearing	21 Cylinder dowel
4 Bolt, sprocket	13 Cover	22 Damper nut
5 Plain washer	14 Flywheel	23 Starter ring gear
6 Damper, if fitted	15 Flywheel bolt	24 Flywheel
7 Dual sprocket	16 Combi bolt	25 Lock washer
8 Woodruff key	17 Crankshaft pulley	
9 Crankshaft	18 Torsion damper	

Re-check the crankshaft end float as described during removal. Attach the dial gauge to the crankcase as shown in Fig. 1.47. The remaining operations are carried out in reverse order to the removal procedure. The various sections give detailed description of the relevant operations, i.e. piston and connecting rods, rear oil seal flange, timing mechanism, flywheel and clutch or drive plate, oil pump, oil sump and cylinder head.



1.3.3.4. Flywheel or Drive Plate (Automatic)

Figs. 1.54 and 1.55 show the end of the crankshaft together with the flywheel and the driven plate respectively. Always check the height of the old flywheel before fitting a new one.

Fig. 1.54 - Arrangement of the flywheel with manual transmission.

1 Starter ring gear
2 Spacer washer
3 Crankshaft
4 Flywheel
5 Stretch bolts, M10
6 Ball bearing
7 Retaining ring

Fig. 1.55 - Arrangement of the flywheel with automatic transmission.

- 1 Starter ring gear
- 2 Flywheel
- 3 Drive plate
- 4 Spacer washer
- 5 Stretch bolts
- 6 Crankshaft

Both flywheel and drive plate can be replaced with the engine fitted without re-balancing of the crankshaft. Proceed as described:

- Remove the transmission (Section 3.1.).
- Counterhold the flywheel in suitable manner and remove the clutch after having marked its relationship to the flywheel. Remove the drive plate in a similar manner. 8 bolts are used to secure the flywheel. A hole has been drilled between two of the bores and a similar hole is drilled into the crankshaft. These two bolts must be aligned when the flywheel or the drive plate is fitted. Fig. 1.56 shows the alignment bore in the case of the flywheel. The drive plate has a similar hole.

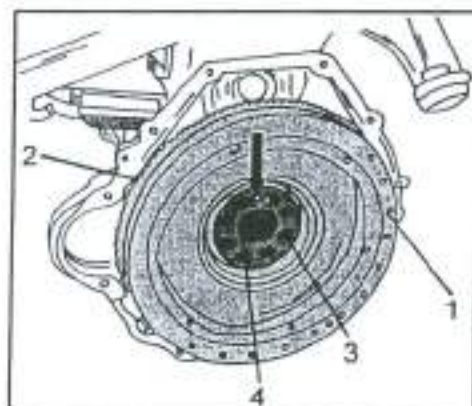
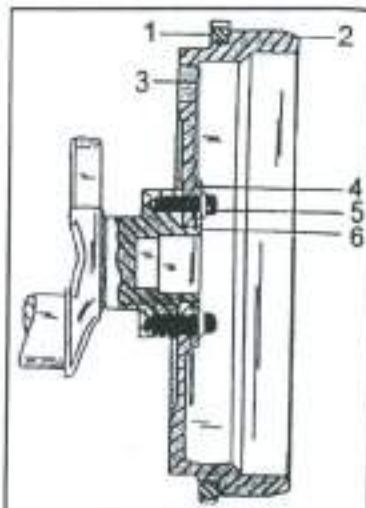

Fig. 1.56 - The arrow points to the alignment bore in flywheel and crankshaft flange. Drive plates are drilled in the same manner.

- 1 Flywheel
- 2 Starter ring gear
- 3 Stretch bolt, M10 x 22
- 4 Ball bearing

- Remove the flywheel or the drive plate. Distance washers are used in the case of the drive plate, which can also be removed. Measure the diameter of the mounting bolts at their smallest section (stretch neck). If less than 8.1 mm, replace the bolts. The measurement is carried out as shown earlier on for the connecting

rod bolts.

- If the flywheel or the starter ring looks worn, take the wheel to your dealer to have the flywheel re-machined and/or the ring gear replaced.

To replace the ring gear of a drive plate, unscrew the ring gear with the steel ring from the drive plate. When refitting the new ring gear, align the bores for the ring gear mounting and the converter and on the drive plate.

Fit the flywheel or the drive plate with the alignment bores in line. Fit a distance washer underneath and on top of the drive plate. Tighten the bolts evenly across to 3.0 - 4.0 kgm (22 - 29 ft.lb.) and from this position a further 90 - 100°. The angle is important to give the stretch bolts their correct tension.

Engines for manual transmissions are fitted with a ball bearing in the end of the crankshaft. A retaining ring, (7) in Fig. 1.54, is used to hold the bearing (5) in position

and must be removed to withdraw the ball bearing with a suitable puller, as shown in Fig. 1.57. To protect the ball bearing, so-called "Viton" washers are fitted on both sides of the bearing. The bearing of earlier 601 four-cylinder engines is bonded in its bore.

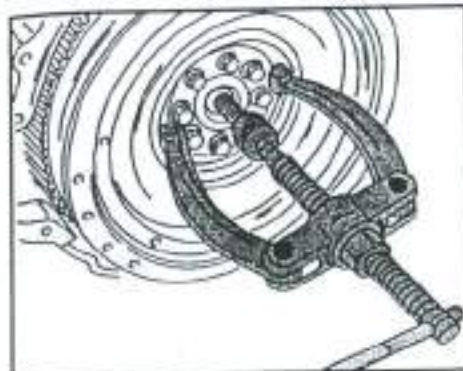

Fig. 1.57 - Removal of the ball bearing inside the crankshaft. The flywheel must be fitted.

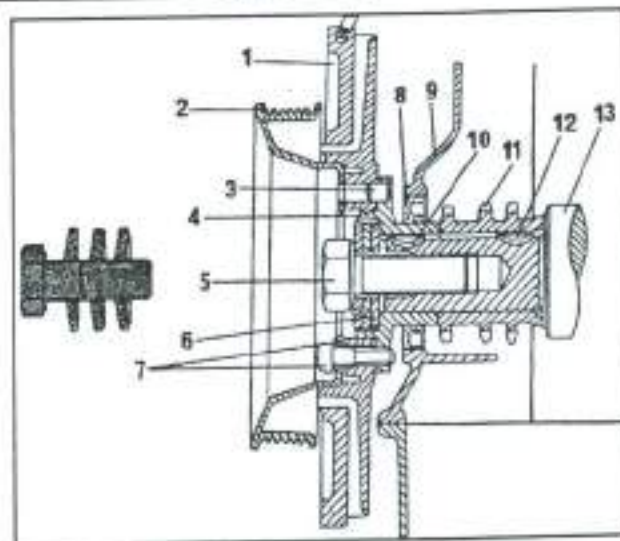

Fig. 1.58 - Sectional view of the crankshaft front end of a four-cylinder engine.

- | | | |
|----------------------|-------------------|------------------|
| 1. Vibration damper | 6. Spring discs | 11. Timing gear |
| 2. Crankshaft pulley | 7. Bolts, M8 x 25 | 12. Woodruff key |
| 3. Dowel pin, 8 x 8 | 8. Oil seal | 13. Crankshaft |
| 4. Pulley hub | 9. Timing cover | |
| 5. Bolt, M18 x 1.5 | 10. Woodruff key | |

1.3.3.5. Crankshaft Pulley and Vibration Damper

The engine is fitted with a crankshaft pulley and a vibration damper. The mounting bolts for the crankshaft pulley are automatically aligned if a dowel pin is inserted into

the corresponding bore. Fig. 1.58 shows a sectional view of the front end of this engine.

Remove the parts as follows, noting that a puller may be necessary to withdraw the hub:

- Lift up the front grille and remove the radiator.
- Release the tension of the drive belt, as described during the removal of the engine.
- Engage a gear and apply the handbrake to lock the engine against rotation. In the case of a vehicle with automatic transmission remove the starter motor and lock the starter motor ring gear in suitable manner.
- Remove the visco-fan clutch together with the fan blades.
- Unscrew the crankshaft pulley with the vibration damper.
- Remove the centre bolt from the crankshaft pulley hub and withdraw the hub with a suitable puller. Make a note of the fitting position of the three spring discs, as they must face the same way during installation.

The crankshaft pulley has a certain diameter. If replaced, quote the engine type and number.

The installation of the crankshaft pulley and the hub or the vibration damper proceed as follows:

- Rotate the crankshaft until the Woodruff key is visible and slide the hub with the key way over the key and the shaft end. Place the three spring discs correctly over the centre bolt, coat the bolt threads with engine oil and fit the bolt. Tighten the bolt to 32.0 kgm. The crankshaft must still be locked against rotation.
- Fit the vibration damper and the crankshaft pulley.
- The remaining operations are carried out in reverse order.

1.3.3.6. Rear Crankshaft Oil Seal and Oil Seal Carrier

The rear crankshaft oil seal is located inside a flange which is bolted to the rear of the crankcase. Two dowels locate the flange correctly in relation to the crankshaft centre. The flange is fitted with sealing compound ("Loctite").

Transmission and flywheel and/or drive plate must be removed to replace the oil seal. If only the oil seal needs replacement, lever it out carefully with a screwdriver without damaging the flange. If the oil seal carrier is to be removed, remove the bolts around the outside edge and two bolts from below. Apply two screwdrivers to the points shown by the arrows in Fig. 1.48 and carefully lever the carrier off the crankcase. The oil seal can now be removed from the inside.



Fig. 1.59 - Removal of the rear crankshaft oil seal. Place a rag underneath the screwdriver to prevent damage.

Clean the carrier and crankcase faces and fit a new oil seal to the carrier (removed or still fitted). The sealing lip of the new oil seal is offset to prevent it from running on the same crankshaft area. Fill the space between the sealing lip and the dust protection lip with grease.

Coat the carrier face with sealing compound and fit it to the block, with the dowel pins engaged. Slightly tap the

carrier in position. Great care must be taken during installation in order not to damage the oil seal.

Fit the bolts. First tighten the two lower bolts and then the other bolts. The torque is 1.0 kgm (7.2 ft.lb.).

Carry out all other operations in reverse order.

1.3.3.7. Front Crankshaft Oil Seal

The front crankshaft oil seal is located in the timing cover. Oil leaks at this position can also be caused by a leaking timing cover gasket. Check before replacing the oil seal.

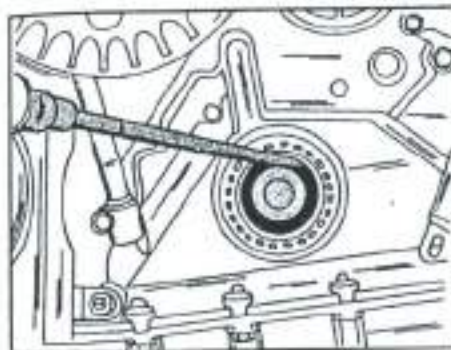

Fig. 1.60 - Removal of the front crankshaft oil seal.

The hub or the vibration damper and the crankshaft pulley must be removed as already described before the oil seal can be replaced. The seal can be carefully removed with a screwdriver (see Fig. 1.60). Screw a self-tapping screw into the outside of the seal and apply the screwdriver plate under the screw head. If the spacer ring on the crankshaft shows signs of wear, remove it with a

suitable puller.

Thoroughly clean the surrounding parts. Burrs on the timing cover bore can be removed with a scraper. Fill the space between sealing lip and dust protection lip with grease and carefully drive a new oil seal into the timing cover and over the crankshaft until the ring outer face is flush. Refit the vibration damper or hub as described in Section 1.3.3.5.

1.3.4. TIMING COVER

The timing cover closes the crankcase at the front. It is located by two dowels and secured by two bolts on the cylinder head, at the bottom by five bolts to the oil sump and 14 bolts to the cylinder block. The sealing between timing cover and engine is ensured by using sealing compound. The following parts are fitted to the timing cover (see Fig. 1.62):

Water pump, fuel filter, the power steering pump, the bearing pin for the tensioning device of the drive belt for alternator, etc., the front crankshaft oil seal, the TDC indication pointer and the guide tube for the oil dipstick.

The timing cover can be removed with the engine fitted. Fig. 1.61 shows the parts to be removed.

- Open the bonnet, and drain the engine oil and the cooling system. Remove the radiator, the visco-coupling and the fan blades.
- Disconnect the battery earth cable.
- Completely remove the tensioning device for the single drive belt. First remove the bolt at the upper end of the shock absorber. Remove the cover from the tensioning lever, unscrew the bolt and remove the washer.

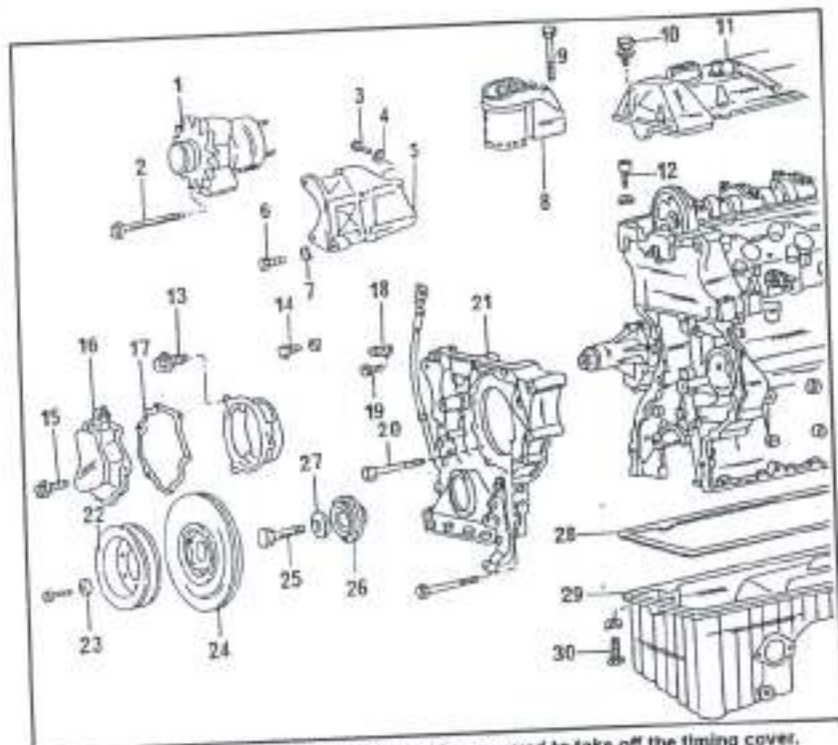
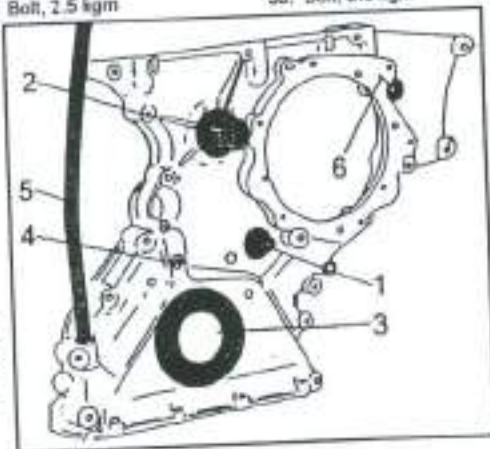

Fig. 1.61 - The illustrated parts must be removed to take off the timing cover.

- | | | |
|-----------------------|-------------------------|----------------------|
| 1. Alternator | 11. Cylinder head cover | 21. Timing cover |
| 2. Bolt, 4.5 kgm | 12. Bolt, 2.5 kgm | 22. Pulley |
| 3. Bolt, 4.5 kgm | 13. Bolt, 1.0 kgm | 23. Washer |
| 4. Washer | 14. Bolt, 1.0 kgm | 24. Vibration damper |
| 5. Alternator bracket | 15. Bolt, 1.0 kgm | 25. Bolt, 32 kgm |
| 6. Bolt, 2.5 kgm | 16. Vacuum pump | 26. Damper hub |
| 7. Washer | 17. Gasket | 27. Spring disc |
| 8. Fuel filter | 18. Bracket | 28. Oil sump gasket |
| 9. Bolt, 1.0 kgm | 19. Bolt, 2.5 kgm | 29. Oil sump |
| 10. Bolt, 1.0 kgm | 20. Bolt, 2.5 kgm | 30. Bolt, 2.5 kgm |

Fig. 1.62 - The timing cover and attached parts.

1. Pin for TDC transmitter (4-cyl.)
 2. Bearing bolt, drive belt tensioner
 3. Crankshaft oil seal
 4. TDC timing pointer
 5. Oil dipstick guide tube
 6. Flange face for exhaustor pump
- Remove the tensioning lever together with the shock absorber and the tensioning spring from the



bearing pin in the timing cover (item "2" in Fig. 1.62).

- If a power-assisted steering is fitted, remove the steering pump pulley.
- Remove the two bolts securing the steering pump, lift off the pump without disconnecting the hoses. Place the pump to one side where it is out of the way.

Fig. 1.63 - The arrows show the 2 securing bolts for the fuel filter.

- Remove the front bolt of the two fuel filter securing bolts (see Fig 1.63).
- Remove the crankshaft pulley hub and remove it. A pulser may be necessary. Otherwise try tyre levers.
- Remove the T.D.C. transmitter (indicates electrically when the piston of No. 1 cylinder is at T.D.C. firing point). To do this, remove the nut (1) in Fig. 1.64, free the cable from the bracket (3) and place the cable to one side, where it is out of the way. On a five-cylinder engine the T.D.C. transmitter has been moved to the R.H. side of the timing cover.
- Unscrew the exhaustor pump (vacuum pump) from the timing cover.
- Remove the alternator together with the mounting bracket.
- If an automatic transmission is fitted, disconnect the oil pipes from the oil cooler. Plug the open ends in suitable manner.

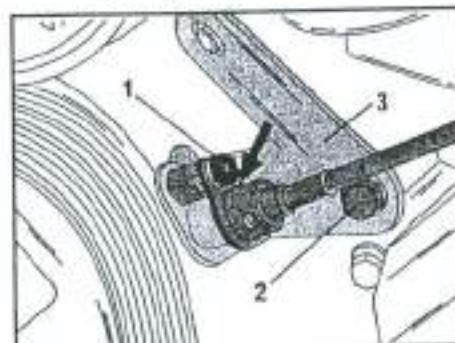
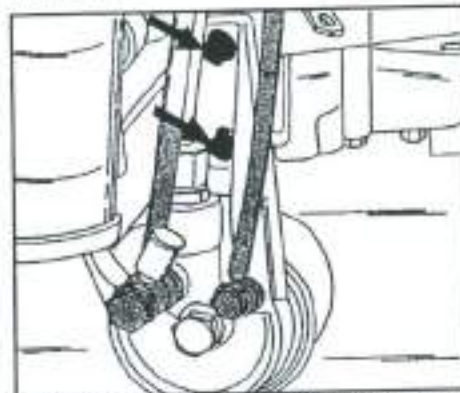

Fig. 1.64 - The TDC transmitter is fitted to the timing cover, shown here for a 4-cylinder engine.

1. Hexagonal nut
2. Hexagonal bolt
3. Bracket for transmitter

- Remove the oil sump securing bolts in the area of the timing cover and then slacken the remaining oil sump bolts.
- Remove the oil sump securing bolts in the area of the timing cover and then slacken the remaining oil sump bolts.

- Remove the cylinder head cover. Two screws are fitted on each side of the cover, two further screws are inserted into the small side on the timing gear end. A breather hose must be disconnected at the centre of the cover. If an automatic transmission is fitted you will have a throttle operating linkage across the cylinder head cover. Disconnect it on one side from the ball joint connection.
- Using a 6 mm Allen key and an extension of at least 440 mm in length, unscrew the two 8 mm cylinder head bolts from the inside of the timing chain chamber. These are the bolts shown with "a" in Figs. 1.14 and 1.15.
- Unscrew the oil dipstick guide tube from the timing cover.
- Unscrew the oil filler elbow and remove it.

- Remove the injection pump securing bolts and the nuts at the pump mounting flange.
- Remove the remaining timing cover bolts and take off the cover. Mark the position of the bolts in suitable manner, as bolts of different length are used. Take care not to damage the cylinder head gasket during cover removal, as this would mean replacement.

Refit the timing cover as follows:

- Carefully clean the sealing faces of the timing cover and the cylinder block from old sealing compound. Also check the sealing face of the cover for damage to prevent oil leaks later on.
- Coat the sealing face of the cover with sealing compound. Mercedes workshops use "Curil T" for this purpose, available under Part No. 001 989 47 20. Carefully fit the timing cover, without damaging the cylinder head gasket.
- Fit the screws into the timing cover, noting their different lengths.
- If the crankshaft oil seal has been replaced, fit it into the timing cover and over the crankshaft end.
- The remaining operations are carried out in reverse order to the removal procedure. Tension the single belt as described in Section 1.8.4. Start the engine and check for oil leaks.

Modifications to Timing Cover and Cylinder Head

The following, important modifications were carried over the years on cylinder head and other associated parts, but it should be noted that not all engines are affected.

Model Year 1985: The cylinder block for the four-cylinder engine has been modified. Also changed is the cylinder head gasket by moving the oil bore. The gasket can be identified by its Part No. Gaskets cannot be interchanged between the two cylinder head types.

Model Year 1989: The combustion chamber in the cylinder head has been enlarged on all engines. Cylinder heads of earlier engines cannot be fitted to cylinder blocks of engines manufactured from model year 1989. The pre-combustion chambers have been adapted to the new cylinder head.

Engines with EGR system have a pressure valve in the cylinder head cover, which prevents the build-up of excessive vacuum (depression) in the engine. A breather hole is drilled into one side of the cylinder head cover (on the R.H. side of the oil filler neck). This hole must not be blocked by oil or other foreign matter. Always check the hole if the cylinder head cover has been removed.

1.3.5. TIMING MECHANISM

The component parts covered in this section can be removed with the engines fitted. The Arrangement of the timing chain and the other timing gear components are shown in Fig. 1.65.

The endless timing chain is engaged with the camshaft sprockets, the injection pump sprocket and the crankshaft sprocket. The chain is guided by two slide rails. The tension of the chain is ensured by means of a hydraulic chain tensioner, which is located in the crankcase and pushes onto a tensioning rail. The camshaft sprocket is fitted by means of an M8 bolt and located by a Woodruff key. Technical data concerning the camshaft are given in Section 1.3.0.0.

A second, smaller chain is used to drive the oil pump. The chain is fitted around a second sprocket on the crankshaft and around the pump drive sprocket and has its own chain tensioner.

Fig. 1.65 - Timing chain and chain drive in fitted position.

1. Injection pump drive gear
2. Crankshaft sprocket
3. Camshaft sprocket
4. Tensioning rail
5. Slide rail
6. Slide rail
7. Chain tensioner
8. Oil pump drive sprocket
9. Tensioning lever for oil pump drive chain

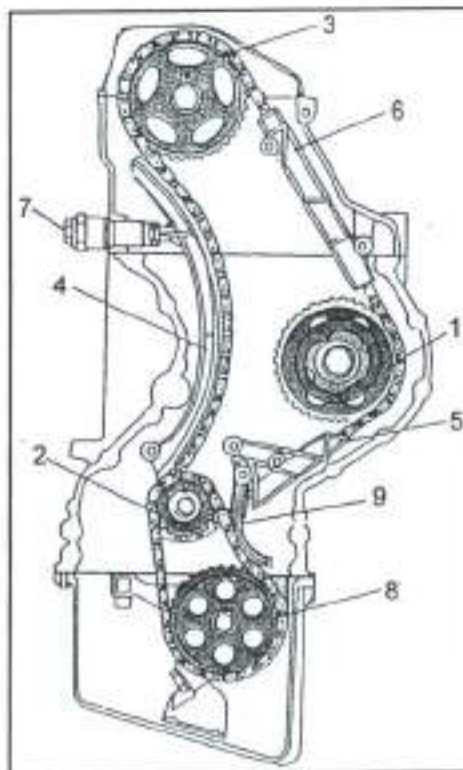

1.3.5.0. Chain Tensioner – Removal and Installation

The chain tensioner is fitted into the side of the cylinder head. The tensioning force of the chain tensioner is a combination of the fitted compression spring and the pressure of the engine oil. The oil contained inside the tensioner also absorbs shock loads from the timing chain. A chain tensioner cannot be repaired, i.e. must be replaced if suspect.

The chain tensioner can simply be unscrewed from the side of the engine, but a hand press is required to refit it properly. A bench-mounted electric drill is, however, sufficient to pre-load the tensioner. Looking at the chain tensioner you will see a large and a small hexagon. Only apply a socket to the large hexagon. Unscrewing the tensioner by applying the socket to the smaller hexagon will result in the tensioner falling internally apart. Fig. 1.66 shows where the chain tensioner is located.



Fig. 1.66 - The chain tensioner (1) is located at the side of the engine.

The chain tensioner must be filled with oil before installation. This requires the use of a hand press (or the drill mentioned above) and a glass jar, filled with SAE 10 engine oil. Hold the tensioner with the thrust bolt facing downwards into the oil. The oil must be above the flange of the hexagon. Using the hand press, push the thrust bolt about 7 to 10 times into the tensioner. As the tensioner is filled with oil, the pressure required to compress it will increase. After

filing the tensioner with oil, check that some force is required to compress it by hand.

Fit a new gasket seals and screw the chain tensioner in position. Tighten the tensioner to 8.0 kgm (58 ft.lb.). The thrust bolt of the tensioner must engage with the tensioning rail as can be seen in Fig. 1.65.

1.3.4.3. Removal and Installation of Timing Chain

Fig. 1.65 shows the arrangement of the timing chain. The following operations can be carried out by referring to this illustration. The sprockets for the camshaft and the injection pump have twice as many teeth as the crankshaft sprocket. Two slide rails guide the chain on one side, a long tensioning rail, operating in conjunction with the hydraulic chain tensioner, is fitted to the other side. Note the following points before commencing any operation:

- A hand-held grinding machine must be available to replace the timing chain with the engine fitted. The new timing chain has a chain lock to connect the two chain ends.
- When an engine has been dismantled, always fit an endless timing chain.
- Before a new timing chain is fitted, check all sprockets. Worn sprocket teeth will very soon wear the new chain.
- Timing chains are sometimes changed during the production of the engine. Always quote the engine type, engine number and model year of the vehicle.

Replace the timing chain with the engine fitted as follows:

- Remove the radiator and the visco-coupling for the cooling fan.
- Remove the injectors (to facilitate the rotation of the engine).
- Remove the cylinder head cover.
- Remove the chain tensioner as described in Section 1.3.5.0. Follow the instructions to prevent the self-dismantling on the tensioner.

Fig. 1.67 - Fit the connecting link from the inside towards the outside.

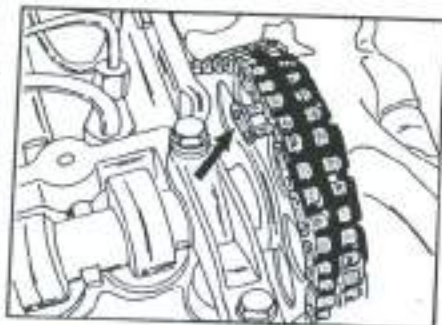

- Cover the chain chamber with rags to prevent grinding particles from falling inside and cut both chain bolts by grinding down one link of the timing chain. Do not remove the chain at this stage.
- Connect the new timing chain with the connecting link to the old chain, at the same time pushing out the old link.
- Slowly rotate the crankshaft in direction of rotation, using a socket applied to the crankshaft pulley bolt. The timing chain must remain in engagement with the camshaft sprocket whilst the crankshaft is rotated. Do not turn the camshaft by applying a spanner to the sprocket bolt.
- Disconnect the old timing chain from the new chain and push the new connecting link from the inside towards the outside through the two chain ends, as shown in Fig. 1.67. Secure the link with the lock washers from the front.
- Rotate the crankshaft until the piston of No. 1 cylinder is at TDC firing point and check that the timing marks (on the crankshaft pulley or the vibration damper) are aligned, with the camshaft in the position shown in Fig. 1.16. The chain is correctly

fitted if this is the case. Otherwise the chain has moved by one tooth and the timing cover must be removed to correct the timing setting.

Refit the timing chain tensioner and carry out all other operations in reverse order.

1.3.5.2. Tensioning Rail - Replacement

The location of the tensioning rail can be taken from Fig. 1.65. The cylinder head and the timing cover must be removed to replace the tensioning rail. The complete tensioning rail must be replaced, as the plastic coating cannot be replaced separately. Remove the rail as follows:

- Remove the drivers seat.
- Remove the cylinder head and the oil filler neck as already described.
- Remove the timing cover (Section 1.3.4.) and the chain tensioner (Section 1.3.5.0.).
- Using paint, mark the relationship between the timing chain and the crankshaft sprocket, similar, as shown in Fig. 1.13 for the camshaft sprocket and mark the camshaft sprocket and chain as shown in this illustration.
- Counterhold the camshaft and remove the camshaft sprocket bolt. Remove the sprocket. Note that the drive sleeve is held to the sprocket with a socket head bolt inside the sleeve.
- Swivel the tensioning rail towards the inside and withdraw from the pivot pin.

Check the plastic coating for wear or damage and replace the rail if necessary. The installation of the tensioning rail is a reversal of the removal procedure. Tighten the camshaft sprocket bolt to 6.5 kgm (47 ft.lb.). The camshaft must be held against rotation at the other end. When fitting the timing chain to the camshaft sprocket make sure that the paint marks are in line.

1.3.5.3. Slide Rails - Removal and Installation

The position of the slide rails is shown in Fig. 1.65. An impact hammer, together with a M6 threaded bolt of 100 mm in length is required to remove the slide rail bearing bolts. The 6 mm bolt is screwed into the end of the bearing bolt and the impact hammer (slide hammer) attached to the end of the bolt. Provided that these tools can be obtained, the rail can be removed as described below. Proceed as follows to replace the slide rail on the cylinder head (6 in Fig. 1.65):



Fig. 1.68 - Remove the two bearing bolts in the manner shown out of the cylinder block.

- Disconnect the battery, the air suction hose, the radiator and the visco-coupling for the cooling fan.
- Remove the tensioning device for the single drive belt. The bearing pin for the tensioning lever of the tensioning device is at the same time the bearing pin for this slide rail.
- Remove the cylinder head cover and the oil filler neck.
- Remove the camshaft sprocket as already described.
- Withdraw the two bearing pins with the impact hammer and a threaded insert, as shown in Fig. 1.68 and lift out the slide rail, if no slide hammer is available, try the following: Slide a piece of tube over the bearing pin and place a washer over

the tube. Screw in a 6 mm bolt and tighten it. With the washer pressing against the tube, the bearing pin will be dislodged as soon as the tube is under tension.

Refit the slide rail as follows:

- Coat the two bearing bolts on the flange with sealing compound.
- Fit the slide rail in position and insert the bearing bolts. Fit the 6 mm bolt and the slide hammer to the end of the bearing bolt and knock the bolt in position, this time hitting the weight of the slide hammer towards the front. Fit the second bearing bolt in the same manner. Counterhold the slide rail during the bearing bolt installation with a screwdriver to prevent distortion. A locating nose in the bearing bolt bore of the slide rail will engage in the locating groove of the upper bearing bolt when the bolt is in position.
- The remaining operations are carried out in reverse order to the removal procedure. Pay attention to the paint marks on timing chain and camshaft sprocket when the parts are refitted.

Replace the lower slide rail (5, Fig. 1.65) as follows:

- Remove the parts as given above to gain access to the timing cover. Then remove the timing cover as described in Section 1.3.4, and remove the slide rail from the two bearing bores. Fit the new slide rail in position and refit the timing cover.

1.3.5.4. Crankshaft Sprocket - Removal and Installation

- Remove the timing cover (Section 1.3.4.) and turn the engine until the piston of No. 1 cylinder is at top dead centre in the firing stroke. Check on the camshaft position as the crankshaft pulley is removed (timing marks cannot be checked).
- Remove the tensioner lever for the oil pump chain ("9", Fig. 1.65).
- Remove the oil pump chain sprocket and withdraw the sprocket, at the same time disengaging the chain from the crankshaft sprocket.
- Mark the crankshaft sprocket and the oil pump drive sprocket to ensure installation in the correct position to each other.
- Mark the timing chain and the camshaft sprocket as shown in Fig. 1.13.
- Remove the camshaft sprocket. The chain can remain in engagement with the sprocket teeth.
- Use a suitable puller and extract the crankshaft sprocket from the end of the crankshaft. Immediately check the condition of the Woodruff key in the crankshaft. A damaged key can be removed with a side cutter. The Woodruff key for the crankshaft pulley hub can be dealt with in the same manner.

Take the new crankshaft sprocket and align the paint mark of the old sprocket with the same tooth of the new sprocket, i.e. the same tooth must be marked in relation to the key groove.

Fig. 1.69 - Fitting the oil pump drive sprocket. The flats shown by the arrows must be engaged.

- If removed, insert the two Woodruff keys. Their flat faces must lie parallel.
- Insert the sprocket into the timing chain (in accordance with the markings) and drive the sprocket over the crankshaft end, using a suitable piece of tube. Make sure that the key is not dislodged.

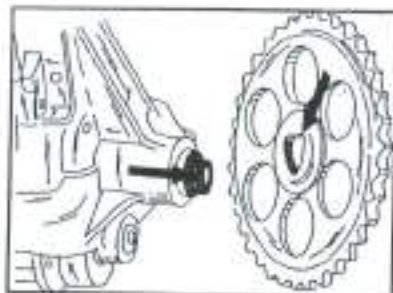

- Refit the camshaft sprocket and the timing chain. Rotate the engine several turns and check that the timing marks at the top of the camshaft are aligned as shown in Fig. 1.16, with the No. 1 piston at top dead centre.
- Fit the oil pump drive sprocket together with the small chain. The inside of the pump sprocket has a locating flat, shown by the arrow in Fig. 1.69, which must be engaged with a corresponding flat on the oil pump shaft.
- Refit the chain tensioner lever and the timing cover. All other operations are carried out in reverse to the removal procedure.

1.3.5.5. Camshaft - Removal and Installation

Except for the number of bearing journals and cams, a similar camshaft is fitted to all 601/602 engines. The shaft of the four-cylinder engine has five bearing locations, the shaft of the five-cylinder has six. To identify the camshaft a number is stamped into the rear face, at the position shown by the arrow in Fig. 1.70.



Fig. 1.70 - Camshafts are marked with a number at the position shown by the arrow.

The camshaft is located in the cylinder head. The lower part of the bearings are machined directly into the cylinder head. Removable bearing caps are used to hold the shaft in position. The camshaft is located in axial direction by a crescent-shaped collar.

A camshaft is removed after removal of the bearing caps and camshaft sprocket.

- Remove the drivers seat, disconnect the battery earth cable and remove the engine bonnet. Also remove the air intake hose.
- Remove the cylinder head cover. 6 screws must be removed. Disconnect the throttle linkage at the ball joint connection if an automatic transmission is fitted.
- Remove the oil filler neck.
- Rotate the engine (in direction of rotation) until the piston of No. 1 cylinder is at T.D.C. compression stroke, i.e. the "0" mark in Fig. 1.12 must be opposite the timing pointer. The crankshaft can be turned by using a 27 mm socket, applied to the crankshaft pulley bolt. Never rotate the crankshaft by applying a socket or spanner to the camshaft sprocket bolt, even if it looks an easy method.

Fig. 1.71 - Counterholding the camshaft sprocket against rotation.

- Remove the chain tensioner as already described (Page 67).
- Mark the camshaft sprocket and the timing chain with a spot of paint (see Fig. 1.13).
- Remove the camshaft sprocket bolt. Insert a metal rod or strong screwdriver into one of the holes, as shown in Fig. 1.71 to prevent the sprocket from rotating.
- Remove the sprocket from the



end of the camshaft. Hold the timing chain tight and tie it suitably together. Under no circumstances allow the chain to disengage itself from the crankshaft sprocket.

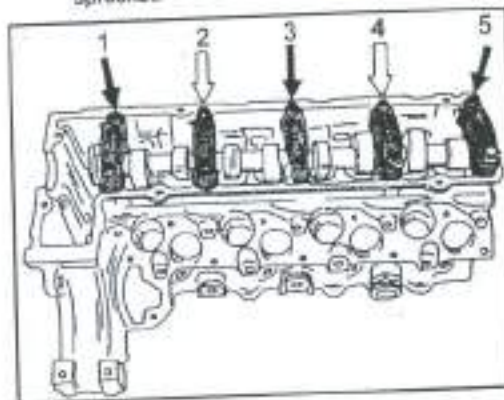
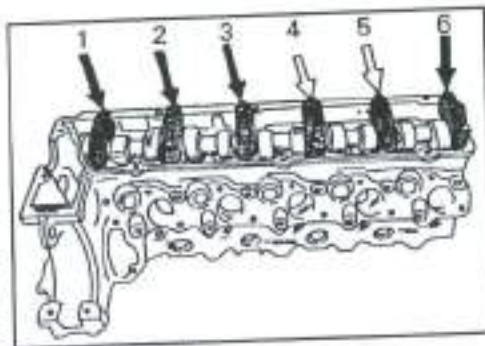

Fig. 1.72 - Camshaft bearing caps of a four-cylinder engine. First remove the caps shown with the black arrows. Then slacken the caps shown with the white arrows evenly across.

• Slacken the camshaft bearing cap bolts in several stages. In the case of a four-cylinder engine, remove the bearing caps No. 1, 3 and 5 in Fig. 1.72 and then slacken the bolts of covers Nos. 2 and 4 alternately until the tension has been released. In the case of a five-cylinder engine refer to Fig.

1.73 and remove the bearing caps Nos. 1, 2, 3 and 6 and slacken the bolts of caps Nos. 4 and 5 evenly across until the caps are free and can be removed. Lay the caps out in their order of removal. The caps are marked with their number and are to be treated accordingly.

Fig. 1.73 - Camshaft bearing caps of a five-cylinder engine. First remove the caps shown with the black arrows. Then slacken the caps shown with the white arrows evenly across.



- Lift the camshaft out of the cylinder head.
- Remove the locating collar from the cylinder head. Fig. 1.74 shows a sectional view of the cylinder head at the camshaft end with the location of the collar. The collar serves to locate the camshaft in axial direction.
- The valve tappets can be removed with a suction tool, but make sure they are inserted into their original bores.
- If a new camshaft is fitted, refer to the identification numbers (shown in Fig. 1.70) or consult your dealer. A new shaft should be inserted into the bearing bores (well oiled) to carry out the following checks:
- Insert the locking collar into the cylinder head. The collar must have sharp edges, otherwise replace it.
- Coat the camshaft journals and place the shaft into the bearing bores. The tappets should not be fitted.
- Fit the camshaft bearing caps in accordance with their numbers and tighten the bolts from the centre towards the outside with 2.5 kgm (18 ft.lb.).
- Screw a bolt, M10 x 30, into the end of the camshaft and tighten it until the shaft begins to turn. Rotate the shaft to notice any "bearing crush". If you feel that the

camshaft shows "hard spots", slacken the bearing caps one at a time. When the troublesome bearing cap has been reached, check the bearing clearance with "Plastigage" as described for the crankshaft. The clearance must be between 0.050 and 0.061 mm.

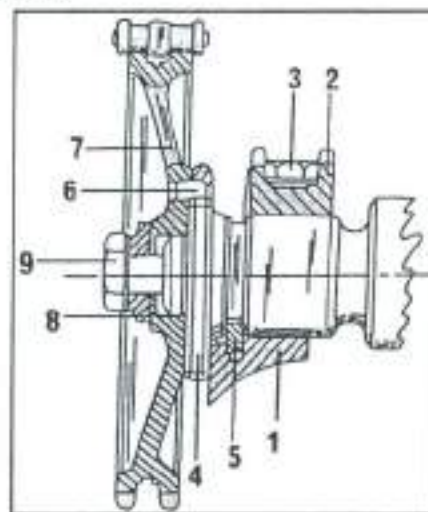

Fig. 1.74 - Sectional view of the camshaft end of the cylinder head.

- | | |
|---------------------|----------------------|
| 1. Cylinder head | 8. Dowel pin |
| 2. Bearing cap | 7. Camshaft sprocket |
| 3. Bolt, M8 x 45 mm | 6. Washer |
| 4. Camshaft | 9. Bolt, M10 x 50 |
| 5. Locking collar | |

- Remove the camshaft.
- Lubricate the tappets with engine oil and insert them into their original bores.
- Insert the camshaft into the bearing bores, with the groove entering the locking collar.
- Fit the bearing caps and tighten them from the centre towards the outside. On the four-cylinder engine first fit the caps Nos. 2 and 4 and then the remaining caps. On the five-cylinder engine first tighten the caps Nos. 4 and 5 and then the remaining caps (refer to Figs. 1.73 and 1.74). The tightening must be carried out carefully to prevent distortion of the shaft through the pressure of the tappets.
- Fit the camshaft sprocket together with the timing chain over the camshaft (hold the chain tight during installation). The dowel pin in the shaft must engage with the hole in the sprocket. Fit the bolt and tighten it to 4.5 kgm (32.5 ft.lb.). The camshaft must be prevented from rotating.
- Refit the chain tensioner as described.
- Check the timing marks on the camshaft in accordance with Fig. 1.16. The marks must align when the piston of No. 1 cylinder is at top dead centre.
- Refit the cylinder head cover.
- All other operations are carried out in reverse order to the removal procedure. After the engine has been assembled start it up and check the areas which were separated for oil leaks.

1.3.5.6. Valve Timing

As the valve timing cannot be adjusted, it is sufficient to obtain the timing mark alignment in Fig. 1.16 to ensure that valves, cams, etc. are in the correct position. Only re-start the engine after you have carried out the check.

1.5. Tightening Torque Values

Values below are valid for the 601 and 602 engines. Refer to the section covering the 616 engine for tightening torque values.

Cylinder Head Bolts:	1.5 kgm (11 ft.lb.)
- 1st stage:	3.5 kgm (25.0 ft.lb.)
- 2nd stage:	90° angle-tightening
- 3rd stage:	Wait 10 minutes
- 4th stage:	2.5 kgm (18 ft.lb.)
Cylinder head bolts (In timing case):	2.5 kgm (18 ft.lb.)
Connecting Rod Bearing Caps:	3.0 kgm (22 ft.lb.)
- 1st stage:	Angle-tighten 90 - 100°
- 2nd stage:	Angle-tighten 90 - 100°
Main Bearing Cap Bolts:	9.0 kgm (65 ft.lb.)
- Without stretch bolts:	5.5 kgm (40 ft.lb.)
- With stretch bolts - 1st stage:	Angle-tighten 90 - 100°
- 2nd stage:	8.5 kgm (47 ft.lb.)
Camshaft sprocket bolt:	8.0 kgm (58 ft.lb.)
Chain tensioner:	1.0 kgm (7.2 ft.lb.)
Cylinder head cover bolts:	2.5 kgm (18 ft.lb.)
Camshaft bearing caps:	1.0 kgm (7.2 ft.lb.)
Injector pipes union nuts:	7.0 kgm (50.5 ft.lb.) + 1.0 kgm
Injectors into combustion chambers:	10.0 kgm (72 ft.lb.)
Threaded ring for combustion chamber in head:	1.0 kgm (7.2 ft.lb.)
Vacuum pump to head:	1.0 kgm (7.2 ft.lb.)
Vacuum pump housing:	32.0 kgm (230.5 ft.lb.)
Crankshaft pulley hub to crankshaft:	2.5 kgm (18 ft.lb.)
Crankshaft pulley to hub:	3.0 - 4.0 kgm (22 - 30 ft.lb.)
Flywheel or driven plate:	Angle-tighten by 90 - 100°
- 1st stage:	1.0 kgm (7.2 ft.lb.)
- 2nd stage:	1.0 kgm (7.2 ft.lb.)
Inlet manifold to cylinder head:	2.5 kgm (18 ft.lb.)
Alternator to mounting bracket:	4.5 kgm (32.5 ft.lb.)
- Bolts fitted from the front:	1.0 kgm (7.2 ft.lb.)
- Bolts fitted from the side:	2.5 kgm (18 ft.lb.)
Bolt for T.D.C. transmitter (sensor):	2.5 kgm (18 ft.lb.)
Bolt for belt tensioner:	2.5 kgm (18 ft.lb.)
Fuel filter bolts:	3.0 - 3.5 kgm (22 - 25 ft.lb.)
Plug in injection pump:	2.0 - 2.5 kgm (14.5 - 18 ft.lb.)
Injection pump flange:	2.0 - 2.5 kgm (14.5 - 18 ft.lb.)
Bolt for rear support bracket:	2.5 kgm (18 ft.lb.)
Banjo bolts for fuel pipes:	2.5 kgm (18 ft.lb.)
Oil drain plug in sump:	1.0 kgm (7.2 ft.lb.)
Oil sump to cylinder block:	2.5 kgm (18 ft.lb.)
- M6 bolts:	1.0 kgm (7.2 ft.lb.)
- M8 bolts:	2.5 kgm (18 ft.lb.)

Exhaust manifold to cylinder head:	2.5 kgm (18 ft.lb.)
Centre bolt, fan to water pump:	2.5 kgm (18 ft.lb.)
Timing Cover:	1.0 kgm (7.2 ft.lb.)
- M6 bolts:	2.5 kgm (18 ft.lb.)
- M8 bolts:	4.5 kgm (32 ft.lb.)
Engine mounting bracket, sides:	4.5 kgm (32 ft.lb.)
Engine mounting, nut from below:	3.0 kgm (22 ft.lb.)
Exhaust manifold to exhaust pipe flange:	2.0 kgm (14.5 ft.lb.)
Exhaust pipe to transmission bracket:	2.5 kgm (18 ft.lb.)
Oil pipes to automatic transmission:	2.3 kgm (17.0 ft.lb.)
Earth strap to chassis:	2.8 kgm (20 ft.lb.)
Coolant drain plug (block):	4.0 kgm (30 ft.lb.)
Bolt for injection timing advancer:	7.0 kgm (50.5 ft.lb.)
Nut for injection timing advancer:	3.0 kgm (22 ft.lb.)
Oil filter to crankcase:	

1.7. Lubrication System

The lubrication system used in the 601 and 602 engines is a pressure-feed system. A gear-type oil pump is driven via the crankshaft by means of a separate chain. The pump is not the same for all engine capacities, the difference being in the width of the pump gearwheels. Some other differences should also be mentioned, although they may not apply to vehicles in the U.K. for example. Fig. 1.75 shows where the pump is located at the front of the engine.

Fig. 1.75 - A single bolt secures the pump drive sprocket in the centre.

- The oil pump of the four-cylinder engine has been changed at the end of model year 1988. Wider pump gearwheels have been fitted, increasing the oil delivery.
- If the engine is equipped with an EGR system a smaller pump drive sprocket is fitted (76 mm instead of 109 mm). The drive chain has been shortened by 6 links. The modification must be remembered, if your vehicle has this system fitted.
- Overhaul or other repairs of the pump are not possible.

A warning light in the instrument panel will light up, when the oil level is approaching the lower limit of the oil dipstick. At least 1 litre of oil should be filled in as soon as possible.

Oil pressure indication is electrical by means of a contact switch, fitted to the lower part of the oil filter. Increased oil pressure increases the resistance in the switch and changes the reading in the instrument accordingly. The oil filter is fitted in upright position to the cylinder block. The oil flows through the filter element from the outside to the inside. A return shut-off valve prevents oil from flowing back through the oil

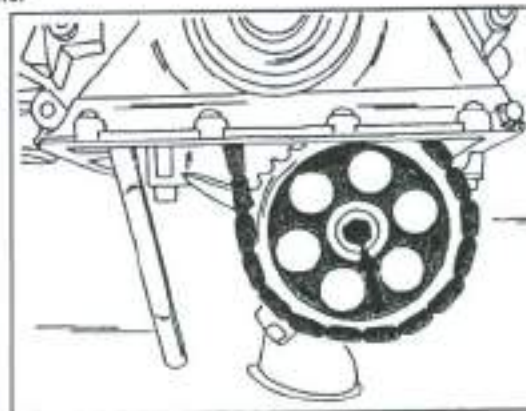

pump into the oil sump when the engine is switched off. A by-pass valve opens when the pressure differential between the dirty and the clean end of the filter exceeds a certain value. The oil is then directed to the oil gallery without being cleaned. It should be noted that the oil filter element must be changed after 600 - 1000 miles if the engine has been overhauled.

The pistons of engines with EGR system are cooled with oil splash jets. The jets are fitted with a screw and a dowel pin to the cylinder block.

The lubrication system of the 616 engine is covered in its own section.

1.7.0. TECHNICAL DATA

Oil Capacities:	See Page 6
Oil pressure at idle speed:	7 psi.
Oil pressure at 3000 rpm:	43 psi.

1.7.1. OIL PUMP - REMOVAL AND INSTALLATION

- Remove the oil sump as described in Section 1.7.2.
- Remove the bolt in the centre of the oil pump drive sprocket (Fig. 1.75) and remove the sprocket together with the drive chain from the pump drive shaft.

Fig. 1.76 - The oil pump in fitted position with the oil sump removed.

- Remove the socket head bolts and take off the pump. Three bolts are used. Two on one side and one on the other side. Fig. 1.76 shows the fitted pump, as seen onto the open crankcase. In the case of the five-cylinder engine a support bridge is fitted to the pump and the bottom of the crankcase, as can be seen in Fig. 1.77, which must also be removed. Also on this engine remove the inlet manifold support bracket.
- If necessary remove the plug for the oil relief valve. The plug is under spring tension and must be pushed towards the inside, before it is fully unscrewed. Remove the internal parts from the bore and check them for wear.

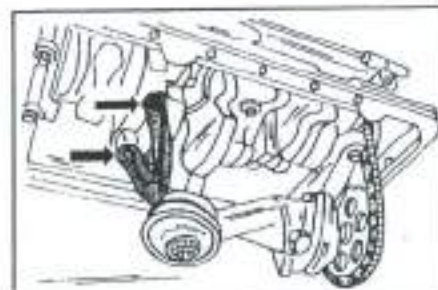
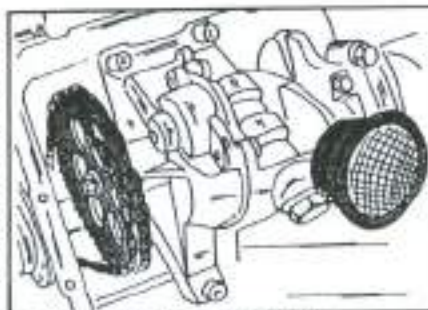

Fig. 1.77 - Remove the support bridge at the points shown by the arrows when removing the oil pump (5-cyl).

The installation is a reversal of the removal procedure. Tighten the pump securing bolts to 25 kgm (18 ft.lb.). When fitting the pump drive sprocket over the shaft, take care to align the flats shown in Fig. 1.69.

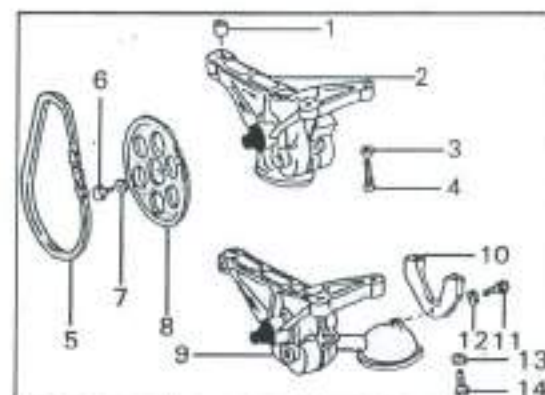

Fig. 1.78 - The oil pump of the 601 and 602 engines.

- | | |
|---------------------|----------------------|
| 1. Dowel sleeve | 8. Oil pump sprocket |
| 2. Oil pump, 4-cyl. | 9. Oil pump, 5-cyl. |
| 3. Spring washer | 10. Support bridge |
| 4. Bolt, 2.5 kgm | 11. Bolt, 1.0 kgm |
| 5. Drive chain | 12. Washer |
| 6. Bolt, 2.5 kgm | 13. Washer |
| 7. Washer | 14. Bolt, 2.5 kgm |

1.7.2. OIL SUMP - REMOVAL AND INSTALLATION

NOTE: The engines have different oil capacities. Refer to Page 6.

Mercedes workshops use special supports to support the engine and transmission from below when the oil sump is removed. As the engine mounting crossmember must be removed, the power unit will drop at the rear and the necessary provisions must be made to prevent this. Either place a jack underneath the assembly or use a small hand crane to lift the engine and transmission until the crossmember is free of load.

- Place a suitable container underneath the oil drain plug. Depending on the engine, up to 8.0 litres of oil will be drained. Remove the oil drain plug and allow the oil to drain into the container. Remove the oil filler cap to speed up the draining of the oil. It also helps, if the engine oil is warm, i.e. drive the vehicle a few miles before the oil is drained.
- If the vehicle is fitted with an electronically regulated idle speed control system, disconnect the sensor from the oil sump.
- Using a socket and an extension, remove the bolt of each of the two front engine mountings.
- Attach a rope or chain to the brackets of the engine and lift the engine with a hoist or crane until the engine lifts enough to take the load of the rear crossmember. The jack mentioned above can also be used, but place wooden planks between jack head and power unit. Fig. 1.79 shows details of the crossmember attachment. Keep the engine in the raised position.
- Remove the oil pipes for the oil cooler from the oil sump (bolt/pipe clamp).
- Unscrew the oil sump and detach it from the cylinder block.

The installation of the oil sump is a reversal of the removal procedure. Fig. 1.79 shows the tightening torques to be observed. Finally fill the oil sump with the correct quantity of the recommended oil. Note the different filling capacities of the various engines (Page 6).

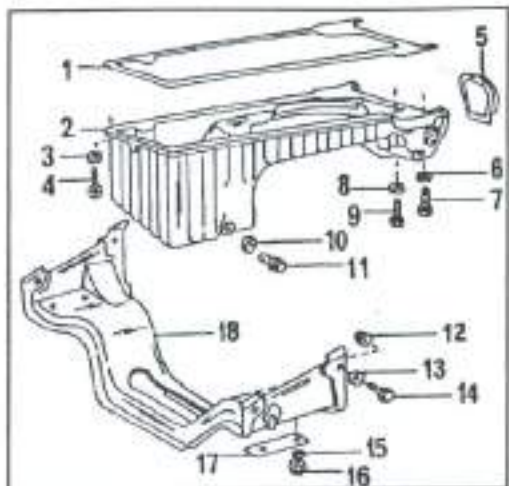

Fig. 1.79 - Details for the removal and installation of the oil sump.

- | | |
|--------------------|---------------------------|
| 1. Oil sump gasket | 9. Bolt, 2.5 kgm |
| 2. Oil sump | 10. Sealing washer |
| 3. Spring washer | 11. Oil drain plug, 3 kgm |
| 4. Bolt, 2.5 kgm | 12. Nut, always replace |
| 5. Cover | 13. Washer |
| 6. Spring washer | 14. Bolt, 4.5 kgm |
| 7. Bolt, 2.5 kgm | 15. Washer |
| 8. Spring washer | 16. Nut, 4.5 kgm (new) |
| 9. Bolt, 2.5 kgm | 17. Reinforcement plate |
| 10. Sealing washer | 18. Crossmember |



Fig. 1.80 - The two nuts (1) secure the cover at the upper end of the oil filter housing. The filter element will appear after removal of the cover.

1.7.3. OIL FILTER

When dealing with the oil filter you will have to differentiate between the replacement of the oil filter element and the oil filter housing. The removal and installation is more complicated as this is normally the case when dealing with an oil filter.

Replacing the Oil Filter Element

It will not be necessary to remove the oil filter housing under normal conditions when the engine is fitted. The removal with the engine removed is straight forward. Replace the filter element as follows:

- Place a suitable container underneath the oil filter and slacken the nuts (1) securing the filter housing cover in Fig. 1.80 without removing them fully.
- Separate the cover from the filter housing, allowing the oil to drain. Completely remove the nuts and lift off the cover.

- Remove the filter element and the sealing rings.
- Fit the new filter element with the new sealing rings and refit the filter cover. Make sure that the oil seals are properly fitted. Tighten the nuts equally to 2.3 kgm (16 f.lb.).
- Check the oil level in the sump and correct if necessary. Start the engine and check for oil leaks in the immediate surrounding of the filter.

1.7.4. ENGINE OIL CHANGE

The engine oil should be changed every 6000 miles. Remember that there are a few litres of engine oil to handle and the necessary container to catch the oil must be large enough to receive the oil. Dispose of the old oil in accordance with the local laws. You may be able to bring it to a petrol station. Never discharge the engine oil into a drain. Drain the oil as follows, when the engine is fairly warm:

- Jack up the front end of the vehicle and place the container underneath the oil sump. Unscrew the oil drain plug (ring spanner or socket). Take care, as the oil will "shoot" out immediately. Remove the oil filler cap to speed-up the draining.
- Check the plug sealing ring and replace if necessary. Clean the plug and fit and tighten to 3.0 kgm (22 f.lb.).
- Fill the engine with the necessary amount of oil. Make sure that the oil is suitable for diesel engines.
- Refit the oil filler cap and drive the vehicle until the engine operating temperature is reached. Jack up the vehicle once more and check the drain plug area for oil leaks.

1.7.5. ENGINE OIL PRESSURE

The oil pressure can only be checked with an oil pressure gauge, which is fitted with a suitable adapter in place of the oil pressure switch. We recommend to leave the oil pressure check to a workshop. Low oil pressure can also be caused through a low oil level in the sump.

1.8. Cooling System

The cooling system operates with an expansion tank, fitted on the R.H. side of the engine compartment. The system will take the quantity given on Page 6. Fig. 1.81 shows a sectional view of the cooling system parts in the case of a four-cylinder engine. The difference in the case of a five-cylinder engine is practically only the additional cylinder.

The water pump is fitted to the front at the bottom of the cylinder block and contains the thermostat with an opening temperature of 87° C.

A fluid coupling with cooling fan is fitted to the engine and operates independently of the engine coolant temperature. The clutch is operated by means of a bi-metal strip, which responds to temperature changes. The clutch is filled with silicone and drives the fan when cooling is required. When the engine is fairly cold, the clutch is disengaged and the fan spins with approx. 1000 rpm. As soon as the temperature reaches approx. 85° C, the bi-metal strip expands and the clutch is engaged. The fan turns now with the same speed as the engine. The heavier drive clutch for the fan required the reinforcement of the water pump housing and the bearing. Fig. 1.82 shows sectional view of the fluid clutch for reference.

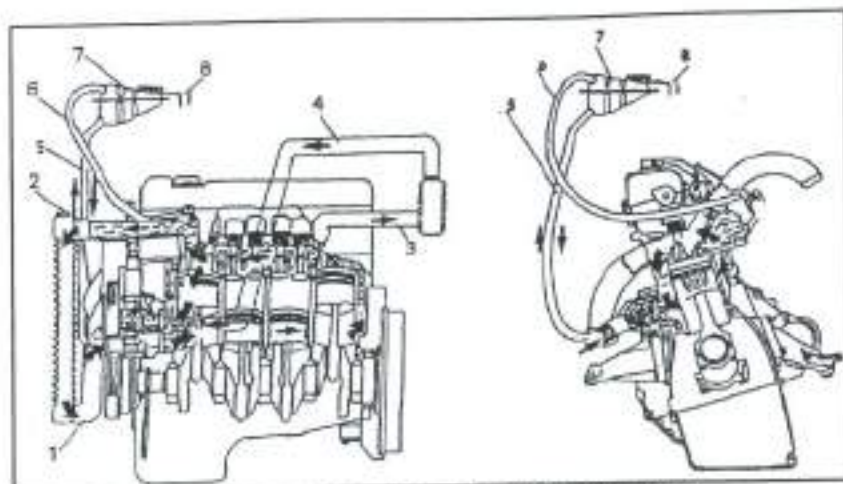

Fig. 1.81 - Sectional view of the cooling system (four-cylinder).

- | | |
|---|---|
| 1. From radiator to water pump via thermostat | 5. Filler hose |
| 2. From cylinder head to radiator | 6. Breather hose |
| 3. Feed to heater (heat exchanger) | 7. Expansion tank (filling for coolant) |
| 4. Return from heater | 8. Overflow hose |

Fig. 1.82 - Sectional view of the fluid coupling for the cooling fan.

- | |
|--------------------|
| 1. Clutch body |
| 2. Cover |
| 3. Drive disc |
| 4. Engagement pin |
| 5. Ball bearing |
| 6. Bearing bush |
| 7. Bi-metal strip |
| 8. Sealing ring |
| 9. Valve |
| A. Fluid chamber |
| B. Working chamber |

A coolant level indicator is fitted into the expansion tank (generally from model year 1985). If the level drops below the "Min" mark for any reason, the switch contacts will close and light up a warning light in the instrument panel. A check of the coolant level is therefore redundant.

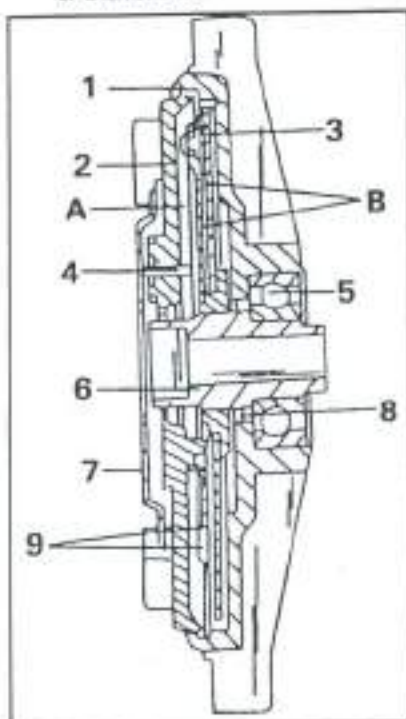

1.8.0. TECHNICAL DATA

Type: Water pump-assisted thermo-siphon system with
 Impeller-type water pump
 Filling Capacity: See Page 6
 Anti-freeze amount: See Section 1.8.1.2
 Thermostat:
 - Opens at 87° C
 - Fully opens at 102° C

1.8.1 COOLANT - DRAINING AND REFILLING

- If the engine is hot open the expansion tank cap to the first notch and allow the pressure to escape. The coolant must have a temperature of less than 90° C.

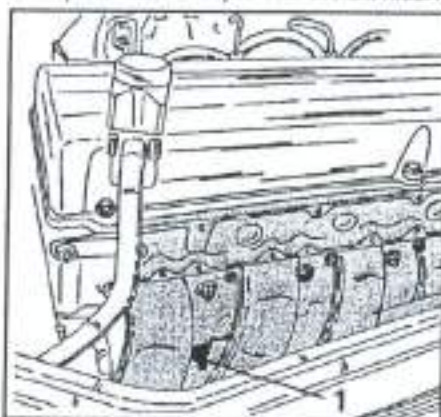

Fig. 1.83 - The coolant drain plug (1) in the side of the cylinder block.

If fitted, remove the noise dampening panel from underneath the vehicle.

- Unscrew the coolant drain plugs. One is located at the bottom of the radiator. A second plug is fitted to the cylinder block, but rather hidden at the position shown in Fig. 1.83. Poke a piece of wire into the bore to dislodge sludge, if the coolant flow is restricted. To ensure that the cooling system is filled without air lock, proceed as follows when filling in the coolant. Refer to Section 1.8.1.0 for the correct anti-freeze amount to be added. Anti-freeze marketed by Mercedes-Benz should be used, as this has been specially developed for the engine.

- Set both heater switches to the max. heating capacity, by moving the controls.
- Fill the pre-mixed anti-freeze solution into the expansion tank filler neck until the level reaches the "Max" mark on the outside of the tank. Do not fit the expansion tank cap at this stage.
- Start the engine and run it until the operating temperature has been reached, i.e. the thermostat must have opened. Fit the cap when the coolant has a temperature between 60 to 70° C. A Thermometer can be inserted into the radiator filler neck to check the temperature.
- Check the coolant level after the engine has cooled down and correct if necessary.
- Refit the noise dampening panel underneath the vehicle, if removed.

1.8.1.0. Anti-freeze Solution

The cooling system is filled with anti-freeze when the vehicle leaves the factory and the solution should be left in the system throughout the year. When preparing the anti-freeze mixture, note the following ratio between water and anti-freeze solution. We recommend to use the anti-freeze supplied by Mercedes-Benz. It may cost you a little more, but your engine will thank you for it. The following ratios should be observed:

To -37° C:

- 3.5 litres anti-freeze, 3.5 litres of water

To - 45° C:

- 3.8 litres anti-freeze, 3.2 litres of water

1.8.2. RADIATOR AND COOLING FAN

1.8.2.0. Checking Radiator Cap and Radiator

The cooling system operates under pressure. The expansion tank cap is fitted with a spring, which is selected to open the cap gasket when the pressure has risen to 1.2 kg/sq.cm. If the cap is replaced, always fit one with the same marking, suitable for the models covered.

To check the radiator cap for correct opening, a radiator test pump is required. Fit the pump to the cap and operate the pump until the valve opens, which should take place near the given pressure (1.2 kg/sq.cm. = 17 psi). If this is not the case, replace the cap. Fig. 1.84 shows the working principle of such a test pump.

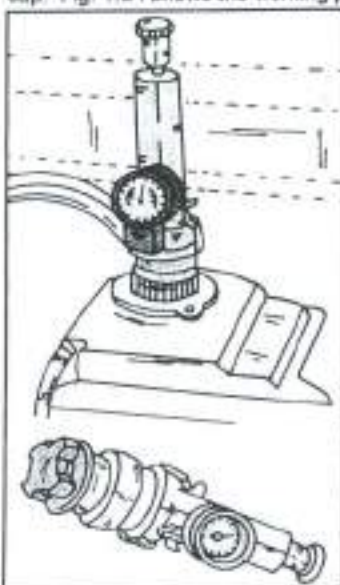

Fig. 1.84 - A radiator test pump is used to check the cooling system for leaks and the expansion tank cap for correct opening.

The same pump can also be used to check the cooling system for leaks. Fit the pump to the expansion tank filler neck and operate the plunger until a pressure of 1.5 kg/sq.cm. is indicated. Allow the pressure in the system for at least 5 minutes. If the pressure drops, there is a leak in the system.

1.8.2.1. Radiator - Removal and Installation

The radiator operates in conjunction with an expansion tank, fitted in the engine compartment. An oil cooler is attached to the R.H. header Tank, which can be removed separately (held in position with spring clips). Always quote the engine type and chassis number when a radiator is to be replaced. As already mentioned there is a coolant level indicator switch fitted into the side of the expansion tank.

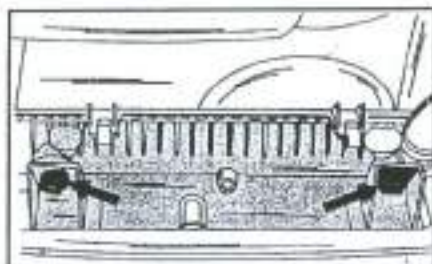

Fig. 1.85 - The radiator is secured at the positions shown by locking spring clips.

The warning lamp must go off as soon as the ignition key is turned to "on". Remove the radiator as follows:

- Drain the cooling system as described in Section 1.8.1. On a model with automatic transmission, use clamps and clamp off the two hoses for the oil cooler. Disconnect the hoses from the R.H. side of the radiator. Some fluid will drip out. Immediately plug the hose ends and connections in suitable manner.

- At the lower end of the radiator remove the locking clips on both sides at the radiator, at the positions shown in Fig. 1.85.
- Remove the strut on the front grill. Disconnect all coolant hoses from the radiator, raise the radiator and detach it from the grille.
- Remove the locking clips for the oil cooler at the top and bottom and detach the oil cooler.
- Remove the radiator complete with the air baffle.



Fig. 1.85 - The two mountings for the radiator are coated with lubricant.

The installation is a reversal of the removal procedure. Moisten the rubber mountings on top of the radiator in Fig. 1.86 with lubricant. After installation of the radiator check that the gap between the fan blades and the radiator air baffle is the same on all sides. If necessary remove the securing clips and centre the baffle.

If an automatic transmission is fitted, re-connect the hose

connections. Check the fluid level in the automatic transmission, if you think some fluid has drained. Finally refill the cooling system as described in Section 1.8.1.

Fig. 1.87 - Sectional view of the fluid coupling.

1. Cooling fan
2. Bolt (3), M5 x 14
3. Bolt, M10 x 40
4. Ball bearing
5. Fluid coupling
6. Belt pulley
7. Bolts (4), M6 x 12
8. Water pump body

1.8.2.2 Fluid Coupling

The removal and installation of the fluid coupling is carried out in a similar manner as described above, with the difference

that there is no need to carry out some of the operations. The coupling is secured with an M10 socket-head bolt. The bolt is tightened to 4.5 kgm (32.5 ft.lb.) during installation.

After installation run the engine and check the fan for correct operation.

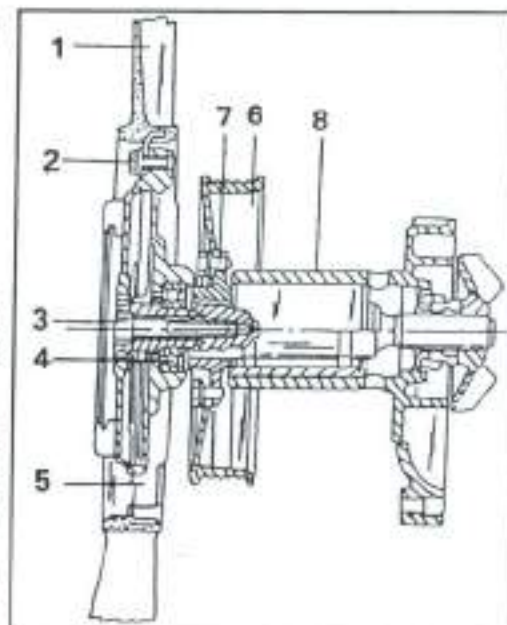

1.8.3. WATER PUMP

The water pump is fastened to a light-alloy housing which is bolted to the lower front of the crankcase. The thermostat is located inside the housing. The fan is attached directly to the pump shaft. Fig. 1.87 shows a sectional view of the water pump with fluid coupling for the fan. Note that the housing and the bearing of this pump have been strengthened to allow for the additional load of the fluid coupling.

The removal of the water pump is a straight-forward operation as it can be unscrewed from the engine after the fluid coupling has been removed as already described. The cooling system must be drained. The light-alloy housing and the hoses remain on the engine.

If the water pump housing is to be removed, proceed as follows after removal of the pump:

- Disconnect the battery earth cable.
- Remove the alternator and place it to one side. Remove the alternator mounting bracket (4 bolts in the centre).
- Disconnect the hoses from the pump housing.
- Disconnect the cable connector plug from the temperature sensor and unscrew the thermostat housing.
- Unscrew the water pump housing from the cylinder block. Immediately clean the mating faces on the cylinder block (and the pump housing, if re-used).

The water pump cannot be overhauled and must be replaced in case of damage or wear.

The installation is a reversal of the removal procedure. If a gasket is used, attach it with two or three spots of sealing compound to the water pump housing. If no gasket is used, coat the water pump thinly, but evenly with sealing compound (Loctite) and fit it to the water pump housing. Tighten the bolts to 1.0 kgm (7.2 ft.lb.). Fit the fluid coupling. Tighten the centre bolt to 4.5 kgm (32.5 ft.lb.).

If the water pump housing has been removed, fit a new "O" sealing ring to the return pipe and push the pipe carefully into the housing. Fit the housing with a new gasket to the cylinder block and tighten the bolts to 1.0 kgm (7.2 ft.lb.). Then refit the return pipe to the cylinder block. The following tightening torques should be observed:

- Alternator mounting bracket 2.5 kgm (18 ft.lb.)
- Alternator to mounting bracket 4.5 kgm (32.5 ft.lb.)

Finally adjust the tension of the single belt as described below and refill the cooling system. Check the cooling system for leaks.

1.8.4. DRIVE BELTS AND DRIVE BELT TENSION

New on these 601 and 602 diesel engines is the arrangement and construction of the drive belt for the water pump and the alternator and any

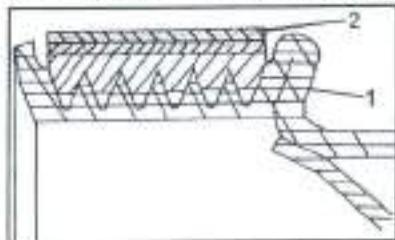

Fig. 1.88 - The arrangement of the poly V-belt in a belt pulley.

- 1 Belt pulley
- 2 Poly V-belt

other belt-driven unit. A single belt, so-called poly V-belt is used to drive the units. The belt has small teeth which engage into

similar teeth in the drive pulleys. Fig. 1.88 shows how the engagement of the belt takes place in one of the pulleys.

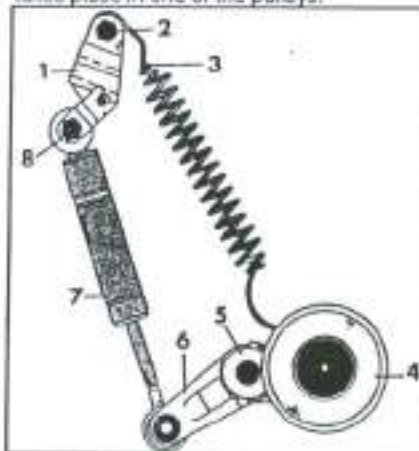

Fig. 1.89. - The component parts of the belt tensioning system.

- 1 Tensioning lever
- 2 Flanged nut
- 3 Tensioning spring
- 4 Tensioning roller
- 5 Cover
- 6 Tensioning roller lever
- 7 Damper
- 8 Upper damper mounting

The tensioner roller of the system is held under constant tension by means of a tension spring. A fitted shock absorber prevents vibration in the belt system. Fig. 1.89 shows the component parts of the system in detail. The tensioning rollers are not the same on all engines. Basic models without additional belt-

driven units have a tensioning roller of similar construction as the remaining pulleys. All other models have a roller with a plain running face.

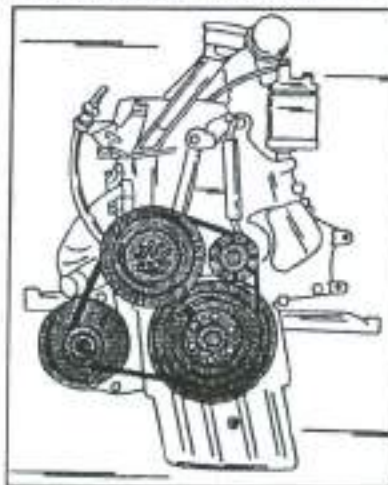

Fig. 1.91 - Layout of the drive belt when a power-assisted steering is fitted.

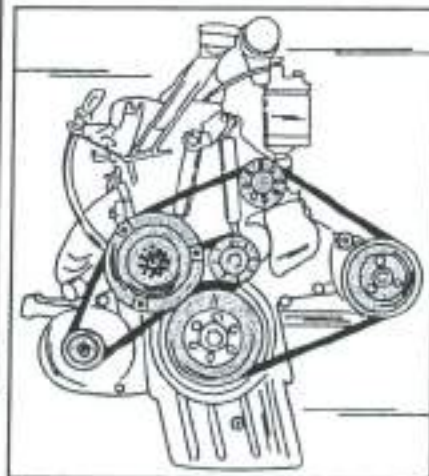

Fig. 1.90 - Layout of the drive belt for basic models without power-assisted steering.

Figs. 1.90 and 1.91 show the belt layout on some of the engines. If an A/C system is fitted, you will find an additional pulley below the pulley for the steering pump. The belt drive should be checked every 12,000 miles. To do this, mark an easy accessible part of the belt with chalk and crank the engine by at least one turn with the starter motor. To prevent the fring of the cylinders, push the stop lever on the injection pump towards the bottom. Ask a helper to operate the starter motor and check the whole length of the belt, i.e. until the chalk

mark can be seen once more. From the condition of the belt you will be able to judge if a new belt is required.

A belt can be replaced as follows:

- Refer to Fig. 1.89 and slacken the flanged nut for the tensioning lever (1). Insert a suitable drift into the spring tensioning lever (1). The drift should have a diameter of 12 - 13 mm and must be 300 mm long.
- Push the drift slightly towards the left until the bolt can be pushed back.
- Move the drift slightly to the right to slacken the tensioning spring.
- Push the tensioning pulley downwards until the belt is slack enough to be taken off. Immediately check the belt profile and the tensioning device for damage. Cracked, burnt or worn out belts must always be replaced. Remember that the tensioning pulley on basic engines without power steering or air conditioning has grooves; other pulleys have a smooth running face.

Always make sure to fit the correct belt. The installation is a reversal of the removal procedure. Place the belt first over the tensioning pulley, ending up at the water pump pulley. Check the belt alignment after the belt has been refitted.

1.8.5. THERMOSTAT

The thermostat is fitted in the upper face of the water pump. A self-bleeding line is inserted between cylinder head outlet and the cooling system expansion tank. The pipe takes care of the air bleeding during the filling of the cooling system.

Fig. 1.92 - Checking a thermostat.

A thermostat is removed as follows:

- Drain the cooling system. Always wait until the temperature is below 90° C. Even then remove the expansion tank cap very slowly. Use a thick rag to protect your fingers and hands. Only turn the cap to its first stop to allow all vapour to escape it is enough to drain the cooling system to the level of the thermostat.
- Unscrew and remove the thermostat cover from the water pump housing. The hose can remain on the cover. Remove the gasket from the thermostat housing and the thermostat.
- A thermostat cannot be repaired, but can be tested by immersing it in a container of cool water and gradually raising the temperature to check the opening temperature.
- Suspend the thermostat on a piece of wire so that it does not touch the sides or the bottom of the container. Suspend a thermometer in a similar manner. Fig. 1.92 shows the arrangement.
- Gradually heat the water and observe the thermometer. The thermostat should begin to open at 87° C and should be fully open at 105° C.

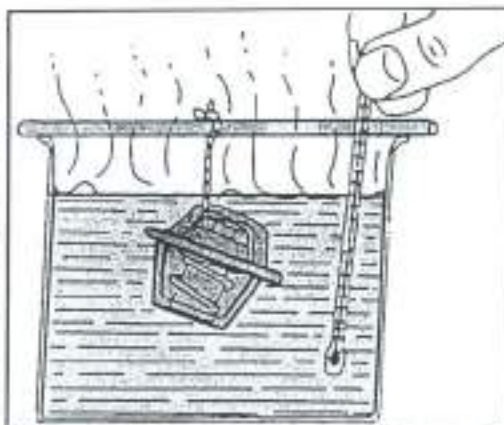

- Otherwise replace the thermostat. The thermostat pin must emerge at least 7 mm from the thermostat. Allow the thermostat to cool down and check if it closes properly.

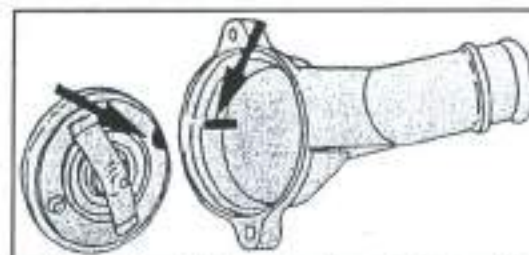

Fig. 1.93 - Correct fitting of the thermostat. The points shown by the arrows must be aligned.

When fitting the thermostat use a new gasket. Fit the Thermostat so that the recess in the thermostat is in line with the lug in the inside of the thermostat housing cover. This is shown in Fig. 1.93. Tighten the cover screws to 1.0 kgm (7.2 ft.lb.). All other operations are carried out in reverse order to the removal procedure. Finally fill the cooling system and check the whole system for leaks.

1.9. Diesel Fuel Injection System

1.9.0. TECHNICAL DATA

Fuel injection pump: FP/KG 24 M 150

Injectors:

- Four-cylinder engine, 601..... DN 0 50 261

- Five-cylinder, 602..... DN 0 50 265

Injector nozzle holder..... KCA 30 S 44 or KCA 27 S 55

Idle Speed - With PLA (pneumatic):

- Four-cylinder..... 750 +/- 20 rpm

- Five-cylinder..... 700 +/- 20 rpm

Idle Speed - With ELR (electronic):

- Four-cylinder..... 750 +/- 5 rpm

- Five-cylinder..... 680 +/- 5 rpm

Opening Pressure of injectors:

- New:..... 115 - 125 bar

- Used:..... min. 100 bar

Fuel tank capacity..... 70 litres

- Optional..... 2 x 65 litres

Absolute cleanliness is essential during any repairs or work on the diesel fuel injection system, irrespective of the nature of the work in question. Thoroughly clean union nuts before unscrewing any of the injection pipes.

Injection pump and injectors are the main components of the fuel injection system. The injection system is basically the same for all engines, but various improvements have been implemented over the years, which will be referred to in the text where applicable. The system of four- and five-cylinder engines (601 and 602) is fitted with a

pneumatically controlled idle speed increase (PLA). 601 and 602 engines with automatic transmission and with conditioning system have an electronically controlled idle speed regulation system (ELR). Again we will refer to these systems later on.

A fuel lift pump sucks the fuel out of the tank and delivers it via a fuel filter to the suction chamber in the injection pump. The injection pump delivers the fuel through high-pressure pipes to the injectors and injector nozzles. Diesel injection systems operate on the principle of direct injection or indirect injection. The Mercedes diesel works with indirect injection, i.e. pre-combustion chambers are used in the cylinder head. The fuel is injected into these pre-combustion chambers which are connected to the main combustion chambers. The combustion of the fuel commences in the pre-combustion chamber. Through the resulting pressure increase, the burning fuel particles are pushed into the main combustion chamber and complete the combustion. The fuel injection pump is a piston pump and is fitted to the L.H. side of the cylinder block and is driven from the timing chain. A pump element, consisting of cylinder and piston, serves each of the engine cylinders.

A governor is fitted to the rear of the injection pump. The governor consists of a system of levers and springs and a centrifugal mechanism, fitted to the rear of the injection pump camshaft. A vacuum unit for the switching off of the engine, a vacuum unit for the idle speed increase (if applicable) and a stop lever on the side of the governor all act on the governor. The injection pump cannot be repaired or overhauled and an exchange pump or a new pump must be fitted in case of malfunction or damage.

The adjustment of the injection timing and also the removal and installation of the injection pump requires certain special tools and these operations should not be undertaken if these are not available. The following text describes these operations, in case that the listed special tools can be obtained or hired.

1.9.0.0. PRECAUTIONS WHEN WORKING ON DIESEL INJECTION SYSTEMS

Whenever repairs are carried out on a diesel fuel injection system, whatever the extent, observe the greatest cleanliness, apart from the following points:

- Only carry out work on diesel injection systems under the cleanest of conditions. Work in the open air should only be carried out when there is no wind, to prevent dust entering open connections.
- Before removal of any union nut clean all around it with a clean cloth.
- Removed parts must only be deposited on a clean bench or table and must be covered with a sheet of plastic or paper. Never use fluffy shop rags to clean parts.
- All open or partially dismantled parts of the injection system must be fully covered or kept in a cardboard box, if the repair is not carried out immediately.
- Check the parts for cleanliness before installation.
- Never use an air line to clean the exterior of the engine when connections of the injection system are open. With the availability of air compressors which can be plugged into a cigar lighter socket, you may be tempted to use air for cleaning.
- Take care not to allow diesel fuel in contact with rubber hoses or other rubber parts. Immediately clean such a hose if it should happen accidentally.

1.9.1. FUEL FILTER

The fuel filter element should be replaced approx. every 40.000 miles. A further filter is fitted upstream of the fuel lift pump and should also be replaced at the same time.

The fuel filter can be removed towards the bottom after unscrewing the bolt in the centre. The vacuum line for the brake servo unit must be removed from the filter base. Thoroughly clean the bottom bowl, if the filter housing remains on the engine, and fit a new filter insert. Always replace the sealing ring. Make sure that the seal is correctly located underneath the head of the centre bolt.

1.9.2. INJECTION PUMP - REMOVAL AND INSTALLATION

A special tool is required to fit the injection pump. This tool (refer to the description) must be obtained before the pump is removed. Also available must be a 27 mm socket (to rotate the crankshaft), a 14 mm ring spanner, with a slot cut into the ring to undo the injection pipe union nuts and a serrated wrench to rotate the injection pump shaft. Provided these tools can be obtained, proceed as follows:

- Disconnect the battery earth cable, remove the radiator and the fluid coupling for the cooling fan, as already described.
- Disconnect the injection pipes and the fuel pipes from the injection pump and carefully bend them to one side. Seal the open connections and fuel hoses at the injection pump in suitable manner, by pushing push-on caps over the connections. Make absolutely sure that no dirt can enter the open connections.
- Rotate the engine (apply the socket mentioned above to the crankshaft pulley) until the piston of No. 1 cylinder is at top dead centre and then slightly further until the 15° mark in the crankshaft pulley/vibration damper is in line with the pointer.
- Remove the single drive belt and the tensioning device as described in Section 1.8.4.
- Remove the timing chain tensioner (Section 1.3.5.0).

Fig. 1.94 - Disconnect the vacuum hoses from connections (1) and (2).

- Disconnect the vacuum connections from the vacuum unit for the idle speed increase and from the unit for the stop control. The two hoses are shown in Fig. 1.94.
- Disconnect the regulating rod for the accelerator control from the injection pump.
- Remove the exhauster pump from the front of the engine (this pump is your vacuum supply for the various vacuum-operated units).
- Remove the bolt (1) in the centre of the injection timing advancer (Fig. 1.95). The crankshaft must be locked against rotation. Note that the bolt has left-hand thread, i.e. the bolt must be slackened in the direction you would normally tighten a bolt.
- Remove the pump securing bolts and the bolt securing the support bracket and withdraw the pump towards the rear.

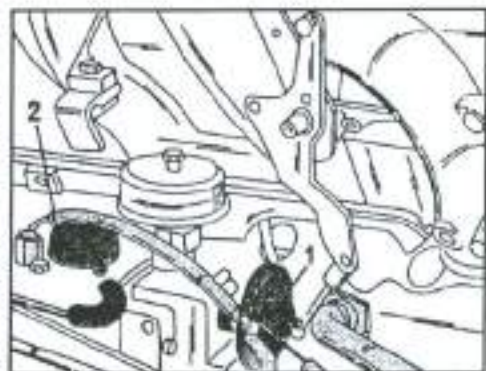

Refit the injection pump in the following order. If the special tool mentioned cannot be obtained, you will be able to have the commencement of injection adjustment is carried out in a workshop.

Fig. 1.95 - The bolt (1) with left-hand thread secures the injection timing advancer to the front of the injection pump.

- Check that the engine is still in the position described above. Otherwise make the necessary corrections, by carefully turning the crankshaft with the 27 mm socket. Remember that the timing chain is engaged with the wheel.

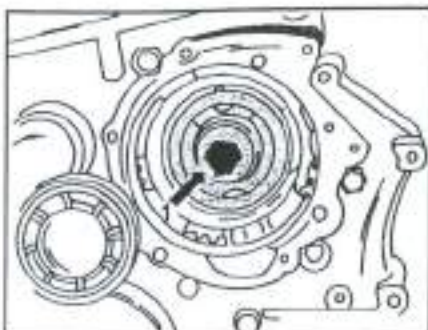

Fig. 1.96 - Locking the governor inside the injection pump, using the special locking pin.

- 1 Injection pump
- 2 Locking bolt
- 3 Governor

- Remove the plug from the side of the injection pump at the position shown in Fig. 1.96. The serrated wrench 601 589 05 21 00 must now be used to rotate the pump until the lug (3) of the governor rotor is visible. In this position insert the locking tool 601 589 05 21 00, as shown in the illustration. Hand-tighten the nut of the locking bolt. If the tools can be obtained, carry out the operation by studying Fig. 1.90. Read the note below.

- The injection pump can now be refitted. Tighten the pump flange bolts to 2.0 - 2.5 kgm (14.5 - 18 ft.lb.). Immediately remove the locking pin from the injection pump and refit the plug.

Tighten the plug to 3.0 - 3.5 kgm (22 - 25 ft.lb.).

NOTE: Immediately after fitting the pump in position remove the locking pin from the side of the pump. The pump can be seriously damaged if this is forgotten.

- Re-connect the injection pipes one after the other. Make sure to engage the threads properly before the union nuts to 1.0 - 2.0 kgm (7.2 - 14.5 ft.lb.).
- All other operations are carried out in reverse order.

1.9.2.0. Checking the Start of Injection Delivery

The start of the injection delivery can be checked in various ways, but every method requires the use of special tools. For this reason we recommend to have the work carried out in a workshop. The following description is only intended to give you some idea what the workshop will do.

- The first method requires a pump, which is used to determine the exact injection point by means of pressure.

- The second method uses a checking gauge, which is inserted into the injection pump at the position shown in Fig. 1.96. By using an instrument with two test lamps, the exact injection point is shown on the degree scale on the crankshaft pulley/vibration damper.
- The third method requires a test appliance with digital indicator.

Fig. 1.97 - The arrow shows where the adjuster for the start of the injection point can be found on the injection pump.

There is also a further possibility to adjust the start of the delivery, if you have experience with diesel engines, as the adjustment must be carried out with the engine running. On the flange end of the injection pump, at the position shown in Fig. 1.97, there is an adjuster. Turning the adjuster towards the right (clockwise) will retard the injection point, turning the adjuster towards the left (anti-clockwise) will retard the injection point. Small corrections are possible with the adjuster.

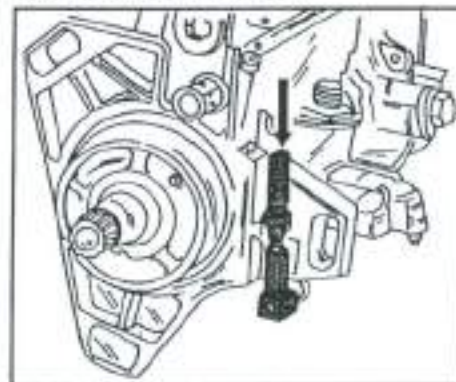

NOTE: Whenever possible have the idle speed adjusted at a Dealer who has the necessary equipment to do it. Remember that a correct idle speed can save you fuel.

1.9.3. INJECTORS

1.9.3.0. Removal and Installation

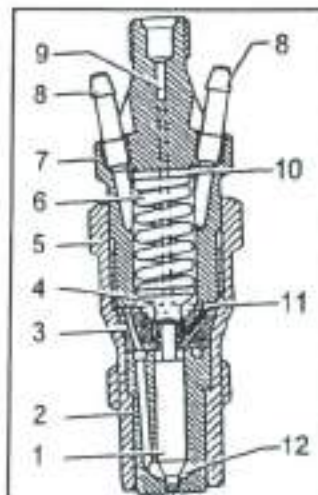

Fig. 1.98 - Sectional view of an injector as fitted to a four-cylinder engine.

- 1 Injector nozzle
- 2 Nozzle body
- 3 Injector holder insert
- 4 Thrust pin
- 5 Union nut
- 6 Pressure spring
- 7 Injector holder
- 8 Leak-off connection
- 9 Fuel feed connection
- 10 Steel washer
- 11 Ring groove and feed bore
- 12 Pressure chamber and injector nozzle

- Remove the driver's seat and disconnect the battery earth cable. Remove the engine cover in the driver's cabin to gain access to the fuel pump.
- Remove the plastic clips securing the injection pipes and disconnect the fuel pipes. Also disconnect the leak-off hoses from the injectors (slacken hose clamps).

workshops. Pack the flutes of the reamer with grease when reaming out the plug channels. The installation of the glow plugs is a reversal of the removal procedure. Plugs are tightened to 2.0 kgm (14.5 lb.). Do not over-tighten the cable securing nuts.

1.9.4.0. Faults in the Glow Plug System

Difficult starting of the engine can in many cases be traced back to the glow plug system. Failure for the warning light to light up will obviously indicate a fault in the system which may be traced with a few simple operations. If a 12 volt test lamp can be made available and you have some experience with electrical systems. First remove the cover from the glow plug relay.

If the warning light does not come on, but the engine starts, check as follows:

- Withdraw the small connector plug from the glow plug relay and switch on the ignition.
- Connect the test lamp to the two terminals inside the plug. The warning lamp should come on. Otherwise check the cables or replace the warning light bulb. To do this remove the combination instrument: Remove the upper foot well covering on the driver's side, the air hose to the side air jet and disconnect the speedometer cable from the rear. Push out the combination instrument from the rear. It is held in position by spring clips.

If the engine does not start and the warning light does not come on:

- Check the fuse strip has burnt out.
- Switch on the ignition and check that there is current at terminal "15". Check with the test lamp on the small terminal with the red/black cable.
- Withdraw the large connector plug with the cables from the glow plug relay.
- Connect the test lamp to earth and hold the other lead of the lamp to the other relay terminals in turn. Each terminal must show current with the ignition switched on. Remember to have the ignition switched on and off every time to re-start the glowing process.
- The relay must be replaced if it fails any of the tests.

A defective glow plug can be suspected if the engine starts, but is not firing on all cylinders immediately. If the "missing" cylinder comes in after a while, replace the glow plug.

1.9.5.1. IDLE SPEED ADJUSTMENT

A professional adjustment of the idle speed can only be carried out with the Bosch Digital Tester and the impulse transmitter 601 589 04 21 00. The tester is plug into the diagnostic plug and the impulse transmitter receives the information from the T.D.C. sender unit above the flywheel.

If, however, you are in possession of a revolution counter, suitable for diesel engines, it will be possible to adjust the idle speed fairly accurate, if the instructions are followed step by step. Connect the revolution counter in accordance with the instructions of the manufacturer.

The idle speed on engines with electronic idle speed regulation (four- and five-cylinder with automatic transmission and air conditioning system) requires no attention.

- Adjust the idle speed when the engine is very hot, i.e. after the vehicle has been driven for a while, allow the engine to cool down before the idle speed is checked

and/or adjusted. Proceed as follows to check and adjust the idle speed: mechanism for freedom of movement over the complete range.

Fig. 1.101 - Disconnect the throttle linkage (1) from the guide lever (2).

- Check the idle speed indication. If the reading is outside the values given in Section 1.9.0, adjust the idle speed.
- Refer to Fig. 1.101 and disconnect the connecting link (1) from the lever (2).

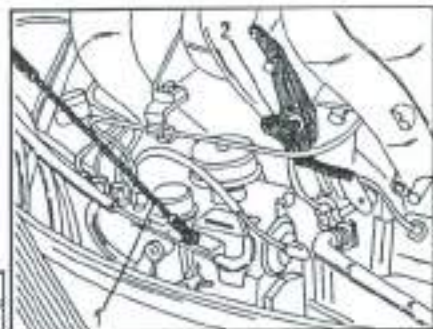
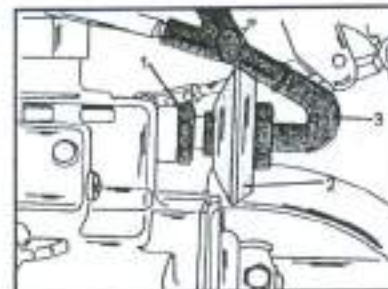

Fig. 1.102. - To adjust the idle speed slacken the locknut (1) and turn the vacuum unit (2), located at the rear of the injection pump).

- Check the throttle operating
- Adjust the idle speed at the vacuum control unit, shown in Fig. 1.102. If adjustments are required, slacken the locknut (1) and turn the vacuum unit. The actual operation is shown in Fig. 1.103, i.e.

the locknut must be slackened with an open-ended spanner.

Fig. 1.103. - The adjustment of the idle speed takes place at the rear of the injection pump. Slacken the locknut with an open-ended spanner (1) and turn the vacuum unit (2).

- Re-start the engine and check the idle speed once more and compare with the values in Section 1.9.0 for the engine in question.
- Re-adjust if necessary as described above.

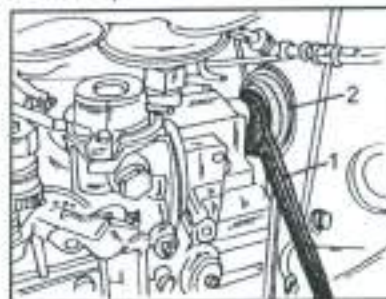

1.9.6. ADJUSTING THE THROTTLE CONTROL

Before carrying out any adjustments check the throttle operating linkage for freedom of movement and the operating cable for freedom of movement or damage. All swivel points must be lubricated with graphited grease. Check and if necessary the throttle control as follows:

- Refer to Fig. 1.104 and disconnect the operating cable. To do this, remove the slotted guide piece (6) from the angle lever (1) and withdraw the cable.
- On a vehicle with automatic transmission disconnect the adjustable connecting link (1) in Fig. 1.105 from the relay lever (3). Check if the adjuster lever on the injection pump is resting against the speed stop. Re-connect the connecting link to the lever, adjusting it if necessary to eliminate any tension. Check that the

roller (4) is resting without tension against the end stop, again without tension (arrow in Fig. 1.105).

Fig. 1.104 - The throttle valve operation.

- 1 Angled lever
- 2 Connector
- 3 Spring
- 4 Adjusting nut
- 5 Operating cable
- 6 Guide piece



- Move the angled lever (1) in Fig. 1.104 in direction "full load", at the same time ensuring that the adjusting lever on the pump is also against the full load stop, if necessary move the adjustable ball joint pin (2) in the slot of the relay lever (3) and retighten the nut (Fig. 1.106).

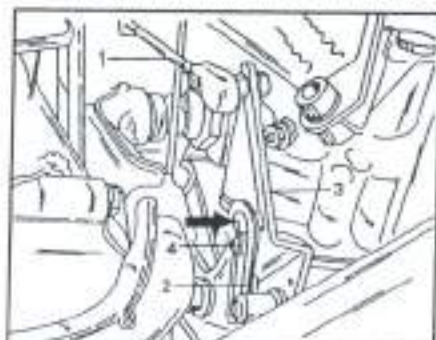

Fig. 1.105 - Details for the throttle control adjustment when an automatic transmission is fitted.

- 1 Connecting link
- 2 Slotted lever
- 3 Guide lever
- 4 Roller

- If a manual transmission is fitted, check if the adjusting lever on the fuel injection pump is resting against the speed full load stop and re-connect the operating cable.

Ask a helper to depress the accelerator

pedal to its floor stop if a manual transmission is fitted or to the stop of if the kick-down switch if an automatic transmission is fitted and check that the lever on the injection pump is resting against its stop. If necessary adjust the adjusting nut (4) in Fig. 1.104 to move the operating cable.

Fig. 1.106 - Adjusting the throttle operating linkage on a vehicle with manual transmission.

- 1 Connecting link
- 2 Ball joint head
- 3 Guide lever
- 4 Lever

Slowly have the accelerator pedal released to bring the throttle control to the idle position and check that the trunnion (2) in Fig. 1.104 contacts the spring (3), but without tension. If tension is felt, the cable must be adjusted from the inside of the vehicle.

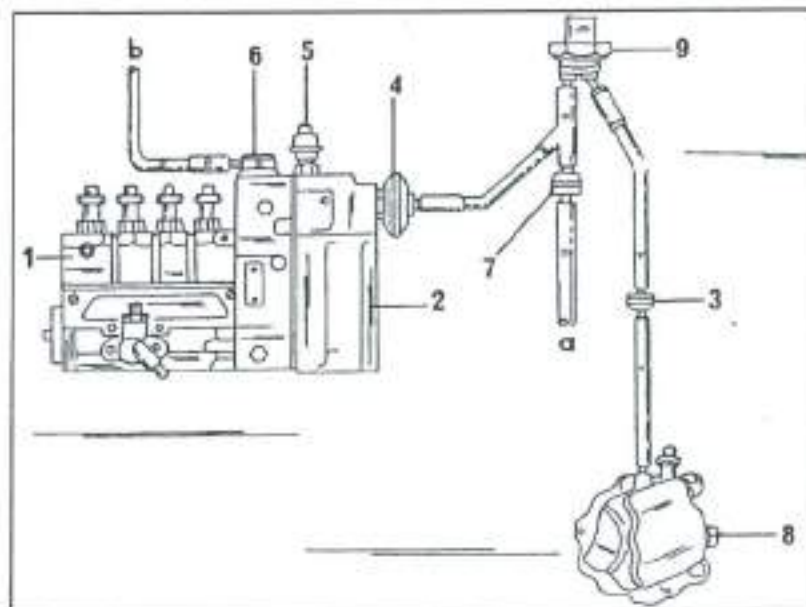
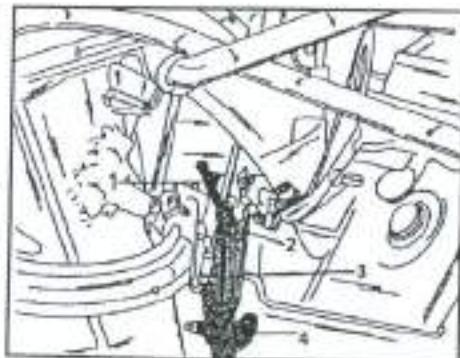

Fig. 1.167 - Diagram of the pneumatic idle speed increase. The various vacuum hoses are coloured and must be marked before removal.

- | | | |
|----------------------------|------------------------|--------------------------------|
| 1 Injection pump | 4 Vacuum hose | 7 Filter with restriction bore |
| 2 Governor | 5 Altitude compensator | 8 Vacuum pump |
| 3 Vent filter | 6 Vacuum shut-off unit | 9 Thermo valve |
| a Vent pipe to drivers cab | b Key, engine shut-off | |

1.9.7. PNEUMATIC IDLE SPEED INCREASE

Both engines operate with this system. The idle speed increase acts via vacuum onto the idle speed stop in the governor. If the engine temperature is less than 30° C (manual transmission, later models) or 17° C (automatic transmission and manual transmission, earlier models), the idle speed will increase by approx. 100 rpm. Fig. 1.107 shows the layout of a typical systems as used on the four-cylinder engine. The vacuum hoses have different colours and must be connected accordingly. Briefly, the system operates as follows. The numbers refer to Fig. 1.107:

When the thermo valve (9), inserted into the vacuum line to the vacuum pump (8) opens, the vacuum will act on the vacuum unit (4) and the idle speed increase takes place. As soon as the valve (9) closes the vacuum supply to the unit (4) is interrupted and the idle speed increase stops.

Faults in the idle speed increase is mainly due to a defective vacuum unit. As the injection pump must be partially dismantled to replace the unit, you will need the assistance of a Mercedes dealer or Bosch service station to rectify the fault.

1.9.8. AIR CLEANER

The air cleaner is made of plastic and consists of three parts, the air cleaner case, the air cleaner cover, connected to which is the large air intake hose and the air cleaner

element, inserted between the two mentioned parts. The air filter housing is connected by means of rubber sleeves to the inlet manifold tubes.

The removal and installation of the air cleaner presents no major problems, but the following points should be noted:

- Remove the air intake hose between the intake and the air cleaner cover.
- Free the fuel pipe from the air cleaner cover and spring back the air cleaner cover clips to remove the cover.
- Remove the air cleaner element to clean it or to replace it. Filter elements must not be cleaned with any fluids. Only compressed air should be used to blow out a dirty element. Always clean the case before fitting a new element. Filter elements are not the same for all engines. Always quote the engine number and the model year. Elements are supplied by Bosch, Knecht, Mann and Furlator. There is no special recommendation which one should be fitted, but insist on an element as used by Mercedes.

1.9.9. ELECTRONIC IDLE SPEED REGULATION

There is more or less nothing you can do on this type of system, fitted to four- and five-cylinder engines with automatic transmission and air conditioning system.

Again a brief description of the operation for the technically minded.

The system consists basically of an engine speed sensor on the flywheel starter ring gear and an electronic control unit. A setting magnet is fitted to the rear of the injection pump, taking the place of the vacuum unit, fitted to other pumps. The speed sensor detects the engine speed and feeds this information to the control unit. The control unit evaluates the information received and compares between the nominal idle speed and the actual speed received. The idle speed is kept at a constant level by the setting magnet, irrespective of the engine load at the time. A coolant temperature sensor, fitted into the cylinder head (near the injection pipes), detects temperatures of less than 60° C and increases the idle speed to a pre-determined value, if necessary.

Due to the electronic regulation of the idle speed you will find that there is no speed variation. The idle speed can be adjusted, if necessary, but we feel that this operation should be left to a Mercedes workshop.

1.9.10. FUEL FEED PUMP

The fuel feed pump is fitted to the side of the injection pump and sealed-off with a gasket. The opening for the fuel pump will allow the oil to drip out of the injection pump, when the pump is removed. Avoid contamination.

The pressure pipe to the injection pump (at the top) is secured with a union nut, the feed hose at the side is secured with a hose clamp. To remove the pump, disconnect the fuel lines and unscrew the pump. Fit the pump with a new gasket and correct the oil level in the pump.

1.9.11. FUEL PRE-HEATER

A heat exchanger is fitted into the feed line to the heating system to pre-heat the diesel fuel for easier combustion in cold condition. A thermostatic control unit is inserted into the fuel lines which directs the fuel to the fuel pump in dependence of the fuel temperatures. Up to a fuel temperature of +8° C, the fuel will flow through the heat exchanger and is warmed-up. Between temperatures of +8 and +25° C a variable operation takes place, i.e. the fuel passes partially through the heat exchanger. As

soon as the fuel temperature increases above 25° C, the fuel by-passes the heat exchanger and is no longer pre-heated.

We recommend that faults in the fuel pre-heating system should be investigated in a workshop.

1.9.12. EXHAUST GAS RE-CIRCULATION SYSTEM

The exhaust gas re-circulation system, mentioned already several times, also known as EGR system, operates under the following conditions:

Fig. 1.108 – View of an injector pump, fitted with the additional features.

- 1 Injection pump
- 2 Governor
- 3 Fuel pump
- 4 Injection pipe connection
- 5 Vacuum unit for atmospheric Dependent full load stop
- 6 Vacuum unit for engine stop
- 7 Vacuum control valve
- 8 Setting magnet for electronic idle speed regulation
- 9 Setting magnet for anti-jerk activation (ARA)

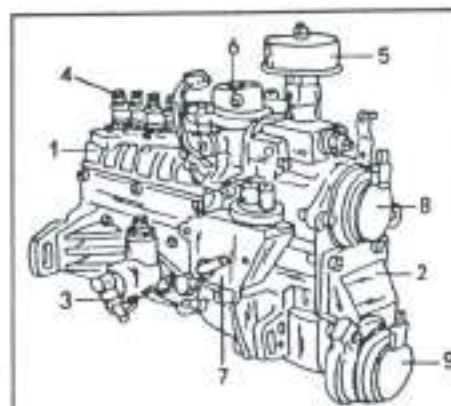

- The engine speed is between 1000 ± 50 rpm and 2950 ± 50 rpm.
- The coolant temperature is between 25° C and 100° C in the case of a four-cylinder engine or 25° C and 97° C in the case of the other engine.
- The speed of the vehicle is less than approx. 50 mph (only five-speed manual transmission).
- The accelerator pedal is not in the full-throttle position (the EGR valve is closed by means of a micro switch just before the full throttle position).
- The pressure control flap is closed between 1000 and 2500 rpm, with a tolerance of 100 rpm either side.

The control unit for the EGR system is fitted to on the L.H. side at the rear of the engine compartment (seen from the front of the vehicle) and receives information about engine speed, driving speed (only with manual transmission), temperature and engine load (position of accelerator pedal and transmits a voltage signal to two switching valves. Fig. 1.108 shows an injection pump when the EGR system is fitted, together with other additional units.

2 CLUTCH

2.0. Technical Data

Type: Single dry plate diaphragm clutch
 Operation: Hydraulic system

Diameter of clutch master cylinder.....	19.05 mm
Diameter of clutch slave cylinder	23.81 mm
Clutch diameter	Refer to parts lists

2.1. Removal and Installation

To remove the clutch unit, it will be necessary to separate the transmission from the engine, with the assembly fitted to the vehicle.

- Remove the transmission (Section 3.1).
- Mark the clutch in its fitted position on the flywheel if there is a possibility that the clutch unit is re-used. To remove the clutch, unscrew the six bolts securing the pressure plate to the flywheel plate and lift off the flywheel and then the driven plate, now free. Before removing the driven plate, note the position of the longer part of the driven plate hub, as the driven plate must be refitted in the same way.

Install in the reverse sequence to removal, noting the following points:

- If the old clutch unit is fitted, align the marks made before removal. A new clutch can be fitted in any position.
- A centering mandrel is required to centre the clutch driven plate inside the flywheel. Tool hire companies normally have sets of mandrels for this purpose. An old transmission (clutch) shaft, which you may be able to obtain from a Mercedes workshop, can also be used. Experienced D.I.Y. mechanics will also be able to align the clutch plate without the help of a mandrel.
- Fit and tighten the six clutch to flywheel bolts to a torque reading of 2.0 kgm (14.5 ft.lb.). The flywheel must be locked against rotation when the clutch bolts are tightened.

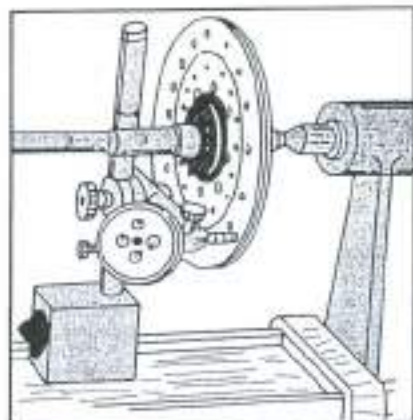

2.2. Servicing

The cover assembly - pressure plate and diaphragm spring- must not be dismantled. Replace, if necessary with a complete assembly from your dealer or distributor.

Fig. 2.3 - To check the driven plate for run-out, clamp it between the centres of a lathe and check with a dial gauge.

Inspect the driven plate and the linings, replacing the complete plate if the linings are worn down close to the rivets. A driven plate with the linings contaminated with grease or oil cannot be cleaned successfully and should also be replaced. All rivets should be tight and the torsion

springs should be sound and unbroken. Check the condition of the driven plate splines. Clamp the driven plate between the centres of a lathe and apply a dial gauge to the outside of the plate as shown in Fig. 2.1, at a diameter of approx. 175.0 mm (6.4 in.). The max. run/out of the driven plate should be no more than 0.5 mm (0.02 in.).

Check the rivet fastening of the clutch pressure plate and replace the plate, if loose rivets can be detected.

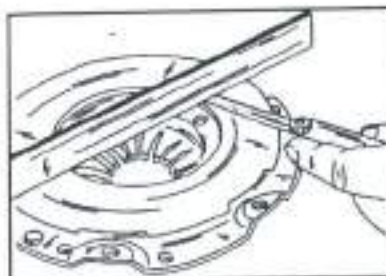

Fig. 2.2 - Checking the clutch pressure plate for distortion. The gap should not be more than given below.

Place a straight edge (steel ruler) over the friction face of the pressure plate and insert feeler gauges between the ruler and the surface. If the gap at the innermost spot of the friction face is no more than 0.03 mm (0.012 in.), the plate can be re-used. Fig. 2.2 shows this check.

2.2. Clutch Release Mechanism

Engagement and disengagement of the clutch is by means of the slave cylinder push rod, acting on the clutch release lever and sliding the ball

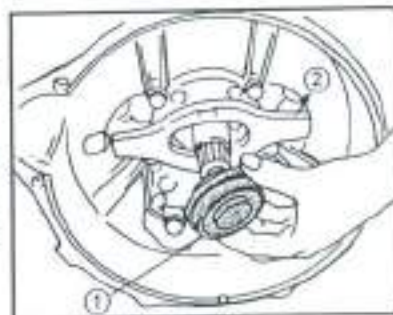

Fig. 2.3. - Removal of the clutch release bearing (1) from the release lever (2).

bearing-type release bearing along a guide tube on the clutch shaft of the transmission. The release system is free of play, as the wear of the clutch linings is compensated automatically.

2.2.0. REMOVAL AND INSTALLATION

The transmission must be removed to replace the release bearing. Remove the bearing from the bearing sleeve on the front transmission housing cover, as shown in Fig. 2.3. To remove the release fork, refer to Fig. 2.4 and move it in direction of arrow (a) and then pull it from the ball pin in the clutch housing in direction of arrow (b).

Fig. 2.4. - Removal and installation of the clutch release lever (see text).
1 Ball pin 2 Release lever

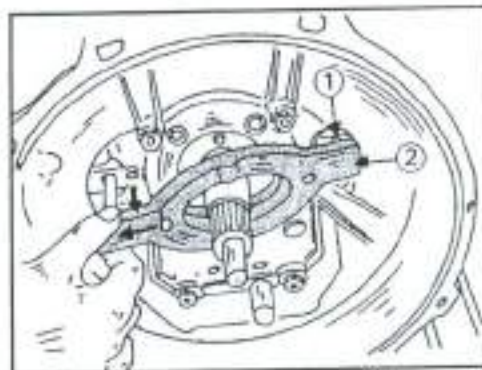

Thoroughly grease the guide sleeve on the front transmission cover, the ball pin and all of the parts of the release mechanism in contact with the release bearing with long term grease. Push the release lever in reverse direction of arrow (b) over the ball pin until the spring clip of the release lever engages with the ball pin. Check for secure fitting. Then move the lever in reverse

direction of arrow (a) until the slave cylinder push rod is engaged with the ball-shaped cut-out in the release lever.

Grease the release bearing on the inside and on both sides at the rear, where it rests against the release lever and slip the bearing over the guide sleeve. Rotate the bearing until it snaps in position into the release lever. Check that the bearing is properly fitted and refill the transmission.

2.2.1. CHECKING CLUTCH LININGS FOR WEAR (clutch fitted)

As the clutch is fully enclosed it is not possible to check the clutch linings on the driven plate for wear. Your dealer has, however, a special gauge which can be used to check the lining wear on the push rod of the clutch slave cylinder, if in doubt about the condition of the clutch, see your dealer. Excessive clutch lining wear can lead to damage to the flywheel friction face (if the rivets of the driven plate rub against the flywheel).

2.3. Clutch Master Cylinder

2.3.0. REMOVAL AND INSTALLATION

Fig. 2.5 shows where the clutch master cylinder is fitted near the clutch pedal. Remove the cylinder as follows:

- Remove cover under the instrument panel, above the pedals.
- Remove the floor mat.

Fig. 2.5 - Clutch master cylinder in fitted position.

- 1 Off-centre point spring
- 2 Spring retainer
- A Pedal travel

- Use a syringe and draw enough fluid out of the fluid reservoir to bring the fluid level below the "Min." mark. Otherwise use a bleeder hose, push it over the slave cylinder bleeder screw, open the screw and operate the clutch pedal until the system is empty (collect the fluid in a glass jar).
- Disconnect the fluid hose from the combination fluid reservoir (for brake and clutch) and unscrew the

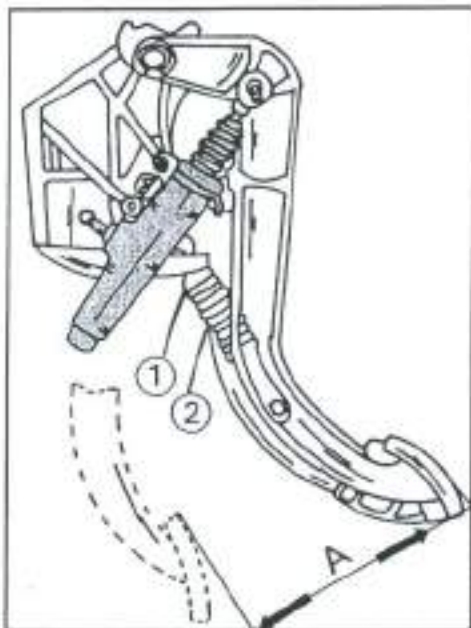

metal pipe from the clutch master cylinder. Dis-connect the electrical plug from the brake light switch.

- Unscrew the master cylinder from the pedal carrier. Pull back the clutch pedal and remove the spring retainer, the spring and the washer from the push rod. Using a pair of circlip pliers, remove the circlip securing the push rod (at the top of the clutch pedal).
- Remove the connecting hose with the push connector and lift out the cylinder.

The installation of the master cylinder is a reversal of the removal procedure. Make sure that the push in connector for the connecting hose is properly in position. Fit the push rod with the flange facing towards the clutch pedal and make sure the circlip engages into its groove. Finally bleed the clutch system (Section 2.5).

Start the engine. Depress the clutch pedal and engage the reverse gear. Grating noises will immediately indicate a faulty release of the clutch operation.

Fully depress the clutch pedal and check that it reaches its stop. Otherwise the clutch cannot fully disengage.

2.4. Clutch Slave Cylinder - Removal and Installation

Cylinders for four- and five-cylinder models are the same. Unscrew the fluid pipe from the slave cylinder, using an open-ended spanner. Close the end of the pipe in suitable manner to prevent fluid leakage (rubber cap for bleeder screw). Remove the two cylinder securing screws and take off the cylinder. Observe the fitted shim. When fitting, insert the shim with the grooved side against the clutch housing and hold in position. Fit the slave cylinder, engaging the push rod into the ball-shaped cut-out of the clutch release lever, and insert the two screws. Tighten the screws. Finally bleed the clutch system as described in the next section.

2.5. Bleeding the Clutch System

A pressure bleeder is used by Mercedes workshops. The following description involves the brake system and is therefore to be treated with caution. Make absolutely sure that the brakes have correct operating pressure after the clutch has been bled. A transparent hose of approx. 1 meter (3 ft.) in length is required. Proceed as follows:

- Fill the brake/clutch fluid reservoir.
- Remove the dust cap of the bleeder screw on the R.H. front brake calliper, push the hose over the bleeder screw and open the bleeder screw.
- Ask a second person to operate the brake pedal until the hose is completely filled with brake fluid and no more air bubbles can be seen. Place a finger over the hose end to prevent fluid from running out.
- Push the free end of the hose over the bleeder screw on the slave cylinder and open the bleeder screw. Remove the dust cap first.
- The following operations must now be carried out in exactly the given order: Depress the brake pedal, close the bleeder screw on the wheel brake cylinder,

allow the brake pedal to return and open the bleeder screw on the wheel brake cylinder. Repeat this operation until no more air bubbles can be seen in the fluid reservoir. During the pumping, keep an eye on the reservoir to make sure it has enough fluid.

- Close the bleed screws on caliper and slave cylinder and remove the hose. Refit the dust caps (easily forgotten).
- Check the fluid level in the reservoir and, if necessary, top it up to the "Max." mark. Start the engine, depress the clutch pedal and engage reverse. No grating noises should be heard.

3 Manual Transmission

The vehicles covered in this manual are either fitted with a four-speed transmission or a five-speed transmission. Depending on the model year and the vehicle type either a gearbox of type G1/18-5/6.15 (four-speed) or G1/19-5/4.7 (five-speed) is used, but both transmissions are of the same basic construction.

The overhaul of the transmission is not described in this manual. The description in the overhaul section is limited to some minor repair operations, not involving the gear train or the gear shafts. If the transmission appears to be damaged or faulty, try to obtain an exchange unit. Transmission overhaul is now limited to specialised workshops which are equipped with the necessary special tools.

3.0. Technical Data

Fitted Transmission:

- Four-speed transmission 711.110 (G1/18-5-5/6.5)
- Five-speed transmission 711.113 (G1/18-5/4.7)

Transmission Ratios

	<i>Four-Speed</i>	<i>Five-Speed</i>
- First gear	3.167 : 1	3.167 : 1
- Second speed	1.619 : 1	1.619 : 1
- Third speed	0.897 : 1	0.969 : 1
- Fourth speed	0.657 : 1	0.543 : 1
- Fifth speed	-----	0.543 : 1
- Reverse speed	2.750 : 1	2.750 : 1

Oil capacity 2.3 litres (approx. 4 pts.)

Lubrication Oil

- Gearbox type 711.110 to No. 571970 ATF (as in A/T)
- Gearbox type 711.110 after above number Gearbox oil, SAE 80
- Gearbox type 711.113 to No. 571266 ATF (as in A/T)
- Gearbox type after above number Gearbox oil, SAE 80

3.1 Removal and Installation

The following text describes the general removal and installation operations of the transmission as fitted to vehicle models 801, 602 and 611. The transmission is heavy and the necessary precautions must be taken when it is lifted out.

- Disconnect the battery earth cable from the battery.
- Pull up the rubber gaiter around the gearchange lever and slacken the clamp screw shown in Fig. 3.1, detach the gaiter and remove the locking ring inside the opening (inside circlip pliers). Withdraw the lower part of the gearchange lever.

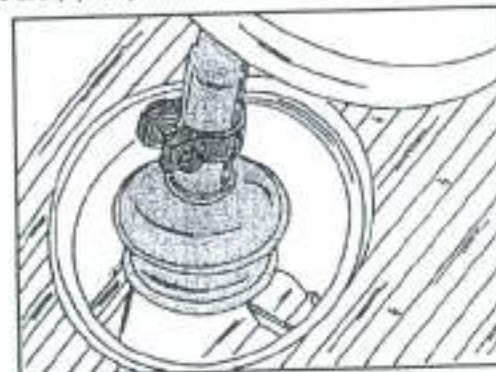

Fig. 3.1 - The upper part of the gearchange lever can be removed after slackening the clamp.

- Detach the cable plug from the reversing light switch and remove the speedometer drive cable (remove one bolt, shown in Fig. 3.2).
- Remove the bracket for the exhaust pipe together with the earth cable.
- Support the transmission from below in suitable manner and unscrew the crossmember, shown in Fig. 3.3.

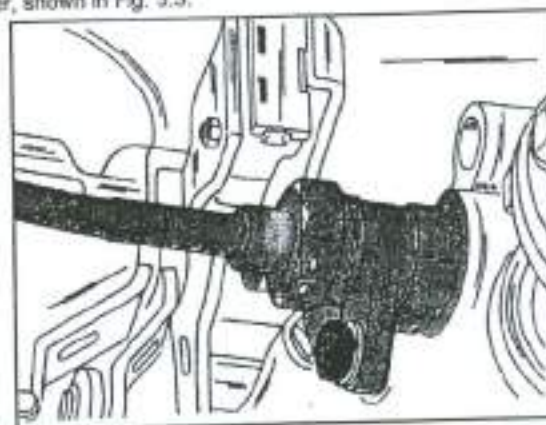

Fig. 3.2 - Speedometer drive cable attachment.

- Unscrew the clutch slave cylinder from the transmission (2 bolts) and withdraw the cylinder. Do not disconnect the fluid hose. The cylinder must be tied up with a piece of wire.
- Unscrew the propeller shaft flange from the transmission flange, move the shaft to one side and tie it to the vehicle floor with a piece of wire.
- Unscrew the gearbox-to-engine bolts from the engine or the clutch bell housing. In the first case it will be necessary to remove the starter motor, secured in position by two bolts. Disconnect the starter motor leads and pull out the unit. Carefully withdraw the gearbox towards the rear. Make sure it is supported well during the removal - Prevent accidents! Never allow the weight of the transmission to rest on the clutch shaft as this may bend the shaft or damage the clutch driven plate or the clutch pressure plate.

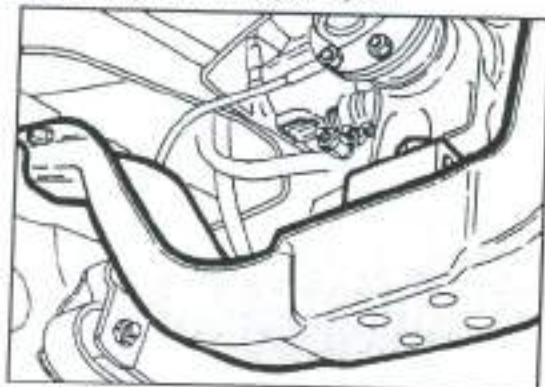

Fig. 3.3 - The crossmember must be removed in order to lower the transmission.

When the transmission is removed for any reason, always check the condition of the clutch mechanism. Remove the clutch and check as described in the previous chapter. Also check the clutch release bearing.

The installation is a reversal of the removal procedure, but the following points must be noted:

- Lightly grease the centering lug and the splines of the clutch shaft with long-term grease. Place the transmission onto the jack and lift it into the approximate fitting position.
- Engage a gear (not reverse), align the transmission with the engine and push the transmission against the engine. Rotate the drive flange at the end of the transmission to and fro until the clutch shaft has engaged with the driven plate. Fully push the transmission against the engine.
- Insert the bolts into the transmission, tighten them evenly until the gap between engine and transmission is nearly closed and then tighten the bolts.
- Refit the rear crossmember, the clutch slave cylinder, the exhaust pipe bracket, the clutch speedometer cable and the cable for the reversing light switch.
- If remove, refit the starter motor (4.5 kgm).
- All other operations are carried out in reverse order. If the oil has been drained, fill the transmission with the correct quantity of the recommended oil (note the differences after a certain transmission number, see Section 3.0).

3.2 Transmission Repairs

Many repairs can be carried out without dismantling the transmission completely. The following sections described some of the jobs which do not need special tools.

3.2.0. FRONT TRANSMISSION COVER

A suitable drift must be available to replace the oil seal in the front cover. Fig. 3.4 shows the parts that will be freed after the cover has been removed. The transmission must be removed from the vehicle.

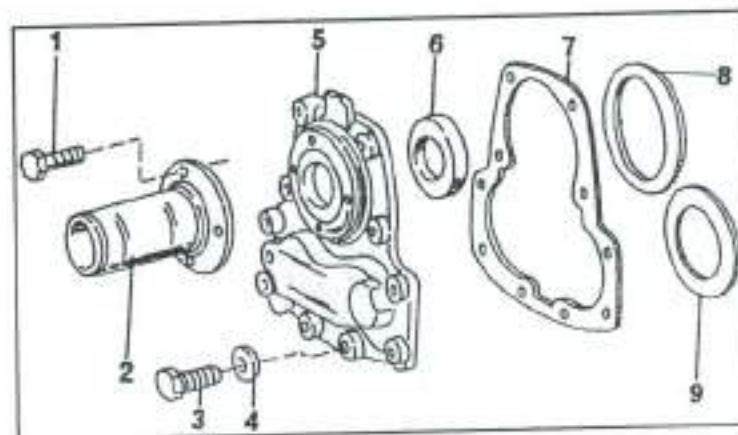
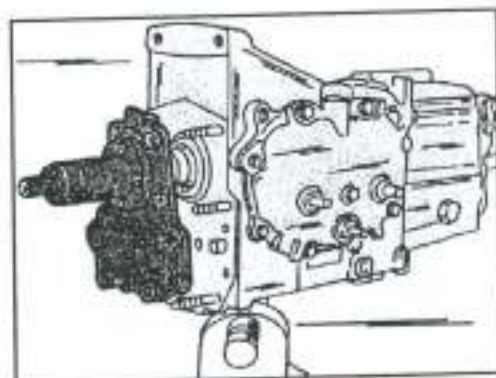

Fig. 3.4 - The component parts of the front cover.

- | | |
|----------------------------|------------|
| 1 Bolt, 1.0 kgm | 6 Oil seal |
| 2 Guide sleeve for bearing | 7 Gasket |
| 3 Bolt, 1.5 kgm | 8 Shim |
| 4 Washer | 9 Shim |
| 5 Front cover | |

Fig. 3.5 - Removal of the front gearbox cover. The gearbox housing must be removed.

- Remove the clutch release bearing from the inside of the transmission case as described in the "Clutch" section.
- Separate the clutch bell housing from the gearbox.
- Unscrew the cover screws on the outside of the transmission case.
- Carefully withdraw the cover over the clutch shaft, as shown in Fig. 3.5. Shims are fitted to the two cover bores, which could either stick to the cover or remain on the bearing. These shims must be refitted. The guide sleeve can also be removed.



- Carefully clamp the cover into a vice, with the inside towards the top, and lever the oil seal out of the cover, using a screwdriver. Place a thick rag underneath the pivot point for the screwdriver.
- Thoroughly clean the cover and fit a new oil seal with a piece of tube. The seal is fitted from the inside of the cover.
- Fit the shims to the cover (attach them with a little grease). Also using grease, stick a new gasket to the cover.
- Coat the oil seal of the sealing lip and the running area for the seal on the clutch shaft with a little grease and carefully slide the cover over the clutch shaft and against the transmission case face. Clean the cover screws and coat their threads with "Loctite 573" sealing compound. Tighten the screws evenly to a torque of 1.5 kgm (11 ft.lb.). Refit the guide sleeve (1.0 kgm/7 ft.lb.).

3.2.1. REAR TRANSMISSION COVER

Again oil leaks may be the reason for the removal of the rear transmission cover. The transmission must be removed to replace the oil seal. A puller is required to remove the transmission housing. The spindle of the puller must press against the gearbox main shaft, with the claws of the puller engaged under the cover. It should also be noted that the drive flange must be heated to 170° C before it is fitted to the gearbox main shaft. You will therefore need a pair of leather gloves. The oil seal is replaced as follows:

Fig. 3.6 - Hold the drive flange as shown when removing the shaft nut with a suitable socket.

- Drain the transmission oil.
- Clamp the transmission into a vice (if possible) and remove the split pin from the slotted nut. Hold the flange in suitable manner, as shown in Fig. 3.6 and slacken and remove the nut.
- Remove the drive flange from the end of the shaft. A two- or three-arm puller may be required.



Fig. 3.7 - Remove the rear cover in the manner shown from the gearbox.

- Remove the speedometer pinion shaft with the bearing from the gearbox cover (remove the screw). Remove the pinion shaft and take off the "O" sealing rings.
- Remove the screws securing the gearbox cover. On one side of the gearbox remove a plug and remove the selector detent and a spring (see Fig. 3.9).

The cover is now removed in the manner shown in Fig. 3.7. Note that the reverse idler shaft remains in the transmission housing. A light cover can be removed with a few taps of a plastic mallet.

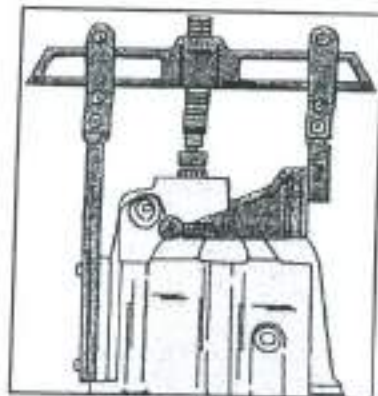

reverse idler shaft remains in the transmission housing. A light cover can be removed with a few taps of a plastic mallet.

- Remove the old oil seal out of the cover (screwdriver) and remove the speedometer drive shaft. The dismantled cover is shown in Fig. 3.8.

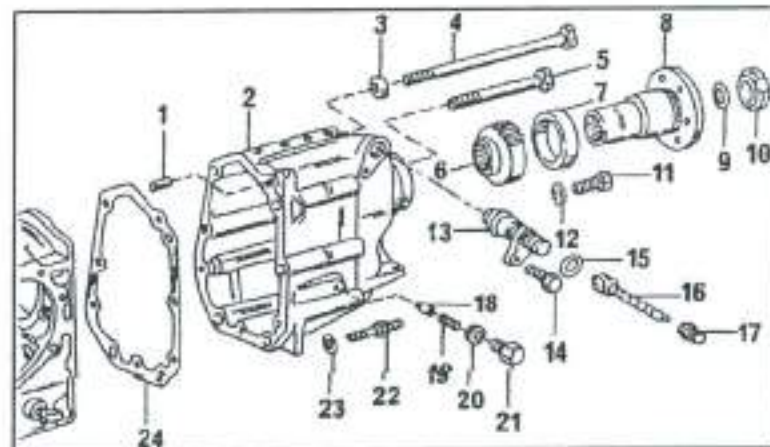

Fig. 3.8 - The component parts of the rear gearbox cover.

1 Dowel pin	9 Washer	17 Closing cap
2 Gearbox cover	10 Nut, 18 kgm	18 Detent plunger
3 Spring washer	11 Bolt, 2.5 kgm	19 Spring
4 Bolt, 5.0 kgm	12 Spring washer	20 Sealing washer
5 Bolt, 2.5 kgm	13 Pinion bush	21 Bolt, 3.5 kgm
6 Speedometer drive gear	14 Bolt, 2.5 kgm	22 Bolt, 2.5 kgm
7 Oil seal	15 "O" sealing ring	23 Sealing washer
8 Washer	16 Speedometer shaft	24 Cover gasket

- Coat a new gasket with grease and place it in position. Check correct installation of the roll pin in the rear cover.
- Heat the inner bearing race of the ball bearing with warm air to facilitate the installation of the cover. Place the cover over the gearbox housing and tap it in position with a piece of tube.
- Coat the cover screws with "Loctite" and tighten the screws with the torque values given in Fig. 3.8.
- Fit the plug shown in Fig. 3.9 with items 18 to 20 in Fig. 3.8 into the transmission cover and tighten the plug to 3.0 - 3.5 kgm (22 - 25 ft.lb.).

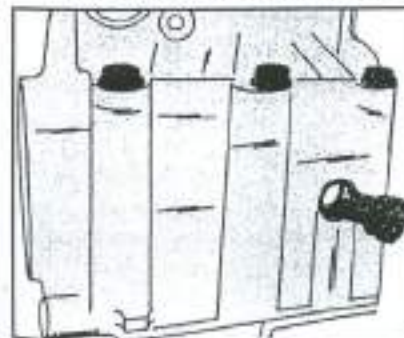

Fig. 3.9 - The gearchange detent is located underneath the plug.

- Push the speedometer drive gear onto the mainshaft.
- Use a suitable piece of tube into the gearbox cover. The sealing seal must be greased.
- Heat the drive flange to 170° C and place the flange without delay over the drive shaft spines. Use a hammer to drive the flange fully in position. Wait until the

flange is completely cold and fit and tighten the slotted nut as shown in Fig. 3.6 to a final torque of 18.0 kgm (130 ft.lb.). Finally fit a new split pin. Take care not to burn yourself on the hot drive flange.

- Fit a new sealing ring into the end of the speedometer pinion shaft bearing and a new "O" sealing ring to the outside of the bearing.
- Insert the speedometer pinion shaft into the bearing and install together in the gearbox cover.
- Finally refit the oil drain plug and tighten to 7.0 kgm (50 ft.lb.).

3.3 Gearbox Oil Level

The gearbox is filled with 2.3 litres of automatic transmission fluid or gearbox oil, as specified in Section 3.0 (depending on the gearbox number). Fluid or oil can only be lost if a leak has developed. To check the oil level, remove the oil filler plug from the side of the transmission and check that the fluid/oil is up to the lower edge of the plug bore. If necessary top-up with the specified oil. A grease gun (thoroughly cleaned) can be used to fill in the required fluid/oil. Refit and tighten the filler plug (6.0 kgm/43 ft.lb.).

Drain the transmission fluid/oil in the usual manner. The drain plug is tightened to 7.0 kgm (50 ft.lb.).

3.4 Gearchange Lever

A clamp is used to attach the gearchange lever to the gearchange stump in the gearbox. To remove the lever, unscrew the gearlever knob, pull the gaiter towards the end of the lever, unscrew the clamp bolt and withdraw the lever.

Refit in the reverse order. Make sure that the clamp is free of grease. Fit the gearlever in position until the gap between lever and connecting sleeve is at least 1.5 mm and tighten the clamp bolt.

3.5 Gearbox - Tightening Torques

Front gearbox cover	1.5 kgm (11 ft.lb.)
Rear gearbox cover, short bolts	2.5 kgm (18 ft.lb.)
Rear gearbox cover, long bolts	5.0 kgm (35 ft.lb.)
Drive flange nut	18.0 kgm (130 ft.lb.)
Gearchange detent plug	3.5 kgm (25 ft.lb.)
Bolt for speedometer drive	2.5 kgm (18 ft.lb.)
Oil level/filler plug	6.0 kgm (43 ft.lb.)
Oil drain plug	7.0 kgm (50 ft.lb.)

4 Front Axle

The following section deals with the actual front axle, including the axle joints and wheel bearings. All parts belonging to the front suspension are described in a separate section.

The front axle is a rigid axle with rubber-bushed axle joints, swivelling around a king pin. The bushes in the steering knuckles can be replaced. The axle is bolted to the two

leaf springs. Wheel suspension is by means of hydraulic telescopic shock absorbers and a stabiliser bar.

Two taper roller bearings carry each wheel hub, i.e. the wheel bearing clearance must be adjusted to obtain the correct wheel bearing pre-load.

A long track rod is fitted between the two steering levers on the steering knuckles. A lever, connected to the steering box, is fitted to the steering lever on the driver's side.

It should be noted that the front axle is not the same on all models covered in this manual.



Fig. 4.1 - View of the assembled front axle.

Fig. 4.1 shows a view of the axle as fitted to the vehicle. The stabiliser bar (anti-roll bar) not shown in the illustration is attached on the L.H. and R.H. side of the front axle and can be removed without any problems.

4.1 Front Axle

4.1.0. Removal and Installation

- Remove the wheel covers and slacken the wheel bolts.
- Place the front end of the vehicle on secure chassis stands. Do not place the stands underneath the axle beam, as the axle must be free for removal. In section "Rear Axle and Drive Shaft" you will find an illustration, with the jacking points to be used. Remove both wheels and place a jack underneath the centre of the front axle.

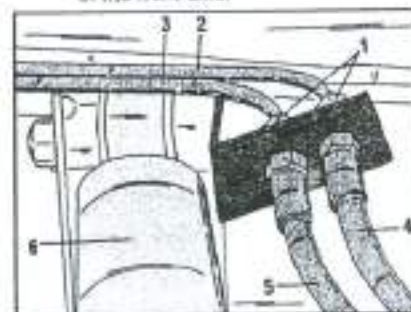

Fig. 4.2 - Attachment of brake hoses to brake pipes.

- 1 Brake pipe union nuts
- 2 Brake pipe from primary piston
- 3 Brake pipe from secondary piston
- 4 Brake hose
- 5 Brake hose
- 6 Shock absorber

- Disconnect the brake hoses by referring to Fig. 4.2. To do this, remove the two brake hose retainers (1), hold the hexagon of the brake hose(s) with an open-

ended spanner and unscrew the union nuts. Withdraw the brake pipes and from below the brake hoses. Close the ends of pipes and hoses in suitable manner to prevent entry of dirt.

- Unscrew the castellated nut of the drag link on the steering lever and using a suitable puller separate the ball joint from the steering lever. Do not damage the rubber boot.

- Operate the jack placed underneath the front axle until the shock absorbers are slightly compressed and remove the lower shock absorber mounting from the front axle. Remove the washers and the spacer bushes.
- Unscrew the stabiliser bar from both sides of the front axle.
- Check that the axle beam is resting securely on the jack and remove the spring "U" bolt nuts, using a socket or a ring spanner (see Fig. 4.3). Carefully knock out the "U" bolts and take off the spring plates.

Fig. 4.3 - Removal or tightening of the spring "U" bolt nuts. When tightening use a ring spanner before applying a torque wrench and socket.



- Carefully lower the front axle and remove the wedges, used for the castor adjustment. Mark the installation position of the wedges. The removed axle must not be rested on the brake disc cover plates - risk of damage.

If repairs are necessary, refer to the corresponding section. The front axle is refitted as follows:

- Place the castor adjusting shims with the thicker ends towards the rear on the front axle.
- Lift the front axle in position. A helper is required to guide the axle beam. Guide the centre pin of the springs into the locating holes in the axle beam and lift the axle further, until it is under slight tension.
- Place the spring plates onto the front axle beam and fit the "U" bolts from above. Take care not to damage the threads.

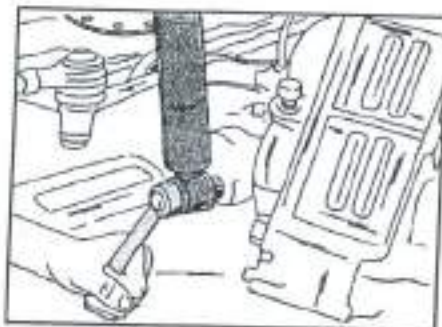

Fig. 4.4 - Fitting a shock absorber to the lower mounting.

- Fit the nuts and tighten them evenly with a ring spanner until fairly tight. Finally use a torque wrench and a socket and tighten the nuts to 8.0 kgm (58 ft.lb.).
- Slip new rubber bushes over the stabiliser bar and refit the stabiliser to the front axle. Tighten the bolts to 3.0 kgm (22 ft.lb.).
- Refit both shock absorbers to the front axle. A spacer bush and a washer is placed between the axle beam and the shock absorber. Tighten the shock absorbers nuts (Fig. 4.4) to 7.0 kgm (50 ft.lb.).

- Refit the drag link to the steering lever. Tighten the nut to 9.0 - 10.0 kgm (65 - 72 ft.lb.).
- Reconnect the brake hoses with the brake pipes in accordance with Fig. 4.2 and bleed the brake system as described in Section "Brakes".
- Refit the wheels, lower the vehicle to the ground and tighten the wheel nuts. Refit the wheel covers.

4.1.1 FRONT AXLE REPAIRS

The bushes for the steering knuckles can be replaced, but we must point out that the ends of the axle beam must be heated to 150°, to fit the king pin into the steering knuckle. The workshop uses a special appliance to heat up the ends of the axle beam. It should be possible to obtain the desired heat, but a melting pencil must be available to indicated when the heat is obtained. Under no circumstances must the temperature be exceeded. Otherwise take the removed axle to a workshop to have the king pin bushes replaced.

A hydraulic press and several drifts to remove and refit the king pin and the bushes will also be necessary. Provided that these conditions are met, proceed as follows:

- Remove the brake assemblies and the wheel hub from the axle, until only the steering knuckles remain on the axle. Clamp the axle beam into a suitable vice.
- Remove the holder from the steering knuckle (Fig. 4.5).

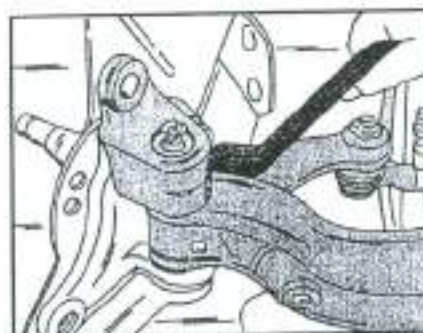

Fig. 4.5 - Removal of the holder from the steering knuckle.

- Remove the split pin from the castellated nut, undo the nut and separate the ball joint connection with a suitable puller from the steering lever. A tight joint can be separated by tightening the spindle of the puller as much as possible and then hitting the end of the puller bolt with a short blow of a hammer.

Fig. 4.6 - Drive out the pin to remove the steering knuckle from the axle beam.

- On the other side unscrew the steering lever (with the steering drag link) from the steering knuckle (two bolts with nuts).
- Unscrew the grease nipple and remove the locking rings on the steering knuckle at the top and bottom. Remove the closing cap with the "O" sealing rings.
- Remove the securing pin on each side of the axle end, using a suitable drift, as shown in Fig. 4.6.
- Remove the king pin out of the axle beam by means of a hydraulic press and a suitable mandrel. Suitable press plates must be used to press the king pin through axle beam and steering knuckle. At the lower end take off the thrust bearing, at the upper end the compensating shim and then withdraw the steering knuckle.
- Clamp the steering knuckle into a vice and drive out the bushes from the inside of the steering knuckle, again using a suitable mandrel.



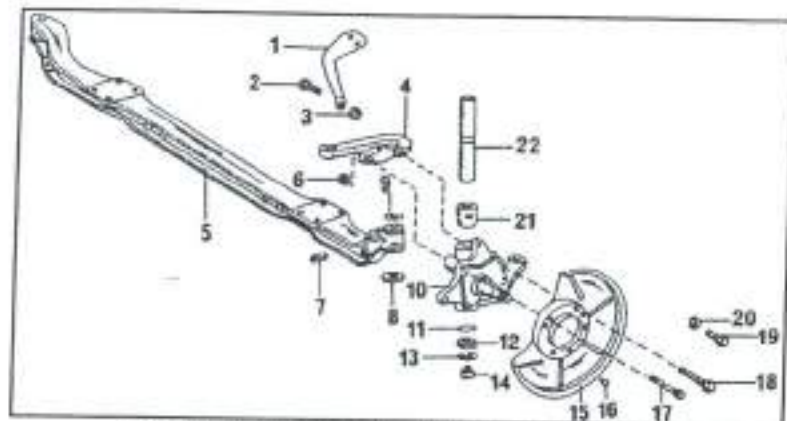

Fig. 4.7 - The component parts of the dismantled front axle.

1 Holder	9 Spacer washer	17 Bolt
2 Bolt	10 Steering knuckle	18 Bolt
3 Hexagonal nut	11 "C" sealing ring	19 Bolt
4 Steering lever	12 Cap	20 Nut
5 Axle beam	13 Securing ring	21 King pin bush
6 Nut	14 Grease nipple	22 King pin
7 Retaining pin	15 Splash shield	
8 Thrust bearing	16 Nut	

Fig. 4.8 - Sectional view of a steering knuckle "a" to "e" show the important dimensions (refer to text).

If an accident was the reason for the removal of the axle, take it to a workshop and have it checked for distortion. The component parts of the axle are shown in Fig. 4.7.

Thoroughly clean all parts and check for wear. The measurements refer mainly to the steering knuckle, which must be measured at the points shown in Fig. 4.8. Important are the diameters "d" of the steering knuckle bore (27.9895 - 28.0105 mm), the diameter "a" for the small wheel bearing (21.426 - 21.439 mm), the diameter "b" for the large wheel bearing (34.919 - 34.930 mm) and the diameter "c" for the oil seal (49.840 - 50.000 mm). Dimension "e" in the illustration can only change after an accident.

The diameter of the king pin should also be measured. King pins are available in one standard size and two oversizes. The bushes are grouped in similar sizes. If the king pin appears still in good condition, you will have to determine which size bushes are fitted. The best solution is to take the king pin to the parts department, when new bushes are purchased, unless pin and bushes are replaced.

The assembly of the front axle is carried out as follows:

- Drive the new bush into the steering knuckle, using a suitable drift. Take care to leave enough room at the lower end in order to fit the sealing ring. Workshops

use a spacer sleeve for this operation which is placed in the position shown in Fig. 4.9.



Fig. 4.9 - Fitting the king pin bush. A spacer washer (2) must be placed in position to drive the bush to the correct depth with a suitable mandrel.

- Fit the sealing ring on the upper bearing, with the sealing lip facing downwards.
- Place the steering knuckle with the thrust bearing and the compensating washer on the front axle beam and centre the parts with a drift of suitable diameter.
- The end of the axle beam must now be heated as described above. The bore of the axle beam end must be free of grease. Drive the king pin in position, at the same time observing through the bore of the axle beam end that the notch in the pin is in line with the bore. Insert the securing pin to secure the king pin.
- Refit the cap, secure it with the locking ring and refit the grease nipple. Fit the holder to the steering knuckle (Fig. 4.5).
- Refit the steering lever to the axle (9.0 - 10.0 kgm/65 - 72 ft.lb.).
- Lubricate the two steering knuckles with a grease gun, until the grease emerges from the gaps.
- All other operations are carried out in reverse order to the removal procedure.

4.2 Wheel Bearings - Adjustment

- Place the front end of the vehicle on chassis stands and remove the front wheel(s).
- Push the brake pads away from the brake disc. If necessary, remove the brake caliper, as the brake disc must rotate freely for a proper check.

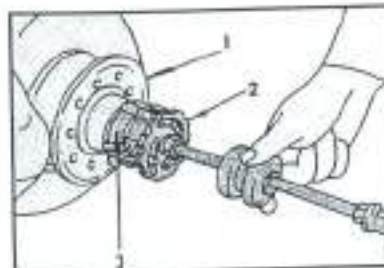

Fig. 4.10 - Removal of the hub grease cap with the special puller (impact hammer).

- Remove the hub grease cup. Normally a puller, as shown in Fig. 4.10, is used. Otherwise you may need an impact hammer, suitably attached to the cap.
- Refer to Fig. 4.11 and slacken the socket head clamp bolt for the nut (2). Rotate the wheel hub evenly and at the same time tighten the clamp nut until the hub can just be rotated.
- From this position slacken the nut by 1/3 of a turn. With a rubber or plastic mallet knock against the end of the stub axle (3) to release any tension in the wheel bearings.

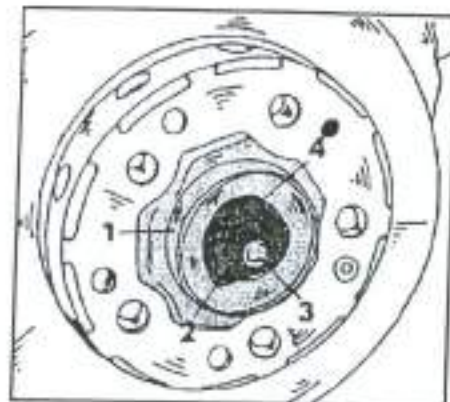

Fig. 4.11 - Details for the front wheel bearing adjustment.

- 1 Front wheel hub
- 2 Clamp nut
- 3 Axle stump
- 4 Thrust washer

Attach a dial gauge to the front wheel hub, as shown in Fig. 4.12. Set the dial gauge to a pre-load of 2.0 mm. The stylus must rest on the centre of the stub axle. Grip the wheel hub with both hands and move it in and out. Before each check, rotate the wheel hub a few turns, but not during the actual measurement. The dial gauge reading must be between 0.02 and 0.04 mm.

If this is the case, tighten the socket head clamp bolt to 1.2 kgm (9 ft.lb.), as shown in Fig. 4.13. Re-check the setting. If the wheel bearing clearance is properly adjusted, it must still be possible to move the washer between the clamp nut and the outer wheel bearing with a small screwdriver.

Fig. 4.12 - Checking the front wheel bearing end float. A dial gauge (2) is attached with a suitable holder (1). The stylus is placed against the end face of the axle stump.

- Fill the grease cap to the inner edge with wheel bearing grease and fit over the wheel hub. Refit the wheel and lower the vehicle to the ground.

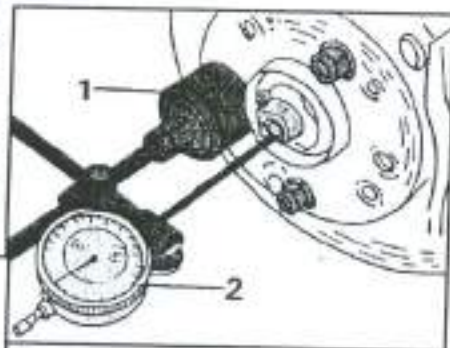
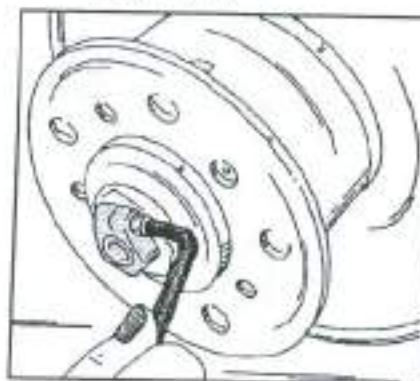

Fig. 4.13 - The wheel bearing adjusting clamp nut is tightened with an Allen key.



4.3 Front Wheel Hubs

4.3.0. Removal and Installation 1

- Jack up the front end of the vehicle and place chassis stands underneath the front axle. Remove the front wheel on the side in question and remove the hub grease cap as described in the last section or in other suitable manner.

- Unscrew the brake caliper from the steering knuckle and suspend it with a piece of wire to the front suspension. Do not allow the caliper to hang down on the brake hose.
- Remove the brake disc.
- Slacken the clamp nut (2) in Fig. 4.10 with an Allen key as shown in Fig. 4.13, unscrew the nut and remove the thrust washer underneath it.
- Remove the wheel hub from the axle stump. A tight wheel hub can be removed with a slide hammer in a similar manner as shown in Fig. 4.10 or a puller is used. Thoroughly clean all parts of the wheel hub and the axle stump and check for wear.

If there is no need to replace the wheel bearings, refit the hub as described below. Otherwise refer to the next section to replace the wheel bearings.

The wheel hub is refitted as follows:

- Slightly coat the running area for the oil seal on the axle stump with wheel bearing grease, push the assembled wheel hub over the stump and drive in position, using a plastic mallet.
- Insert the outer, well greased bearing into the hub and over the axle stump. Again tap the bearing in position. Fit the thrust washer and screw on the clamp nut.
- Adjust the wheel bearings as already described.
- Fit the brake disc over the wheel hub and refit the wheel brake caliper. Tighten the bolts to 19 - 20 kgm (137 - 145 ft.lb.).
- Fill the grease cap with a little bearing grease and knock the cap in position, using a rubber or plastic mallet only.
- Refit the wheels, lower the vehicle to the ground and tighten the wheel nuts to 14 - 18 kgm (100 - 130 ft.lb.).

4.3.1 Wheel Bearings - Replacement

Refer to Figs. 4.14 and 4.15:

- Remove the inner bearing race and the oil seal from the inside of the wheel hub/brake disc, using a two-arm puller. In a similar manner remove the race of the inner bearing from the wheel hub and the outer race of the outer taper roller bearing from the outside of the wheel hub.
- If necessary unscrew the brake disc from the wheel hub. To do this, clamp the brake disc into a vice (soft-metal jaws) and remove the Allen-head bolts from the inside.

Bearings cannot be re-used if the following faults can be detected:

- The rollers of the outer bearing cage show signs of pitting, flaking of the chromium or similar defects.
- Bearing rollers show signs of rust (ingress of water or leaking oil seal).
- Colouration of the outer bearing race (overheating).

If a taper roller bearing must be replaced, replace both bearings as a set. Always use bearings of the same manufacture. If the original bearings are re-used, make sure that bearing races and bearing cages remain together. Refit the bearings as follows:

- If removed, refit the brake disc. Tighten the bolts to 10.5 - 12.5 kgm (75 - 90 ft.lb.).
- Press or drive the outer bearing races from opposite sides into the wheel hub, using a suitable metal drift.

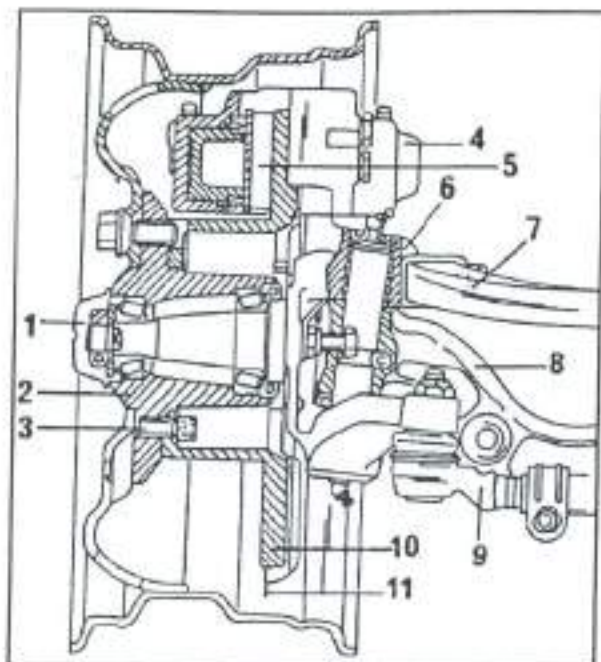

Fig. 4.14 - Sectional view of a front wheel hub.

- | | |
|--------------------|-------------------|
| 1 Hub grease cap | 7 Steering lever |
| 2 Wheel hub | 8 Front axle beam |
| 3 Allen head bolt | 9 Track rod |
| 4 Brake caliper | 10 Brake disc |
| 5 Brake pads | 11 Splash shield |
| 6 Steering knuckle | |

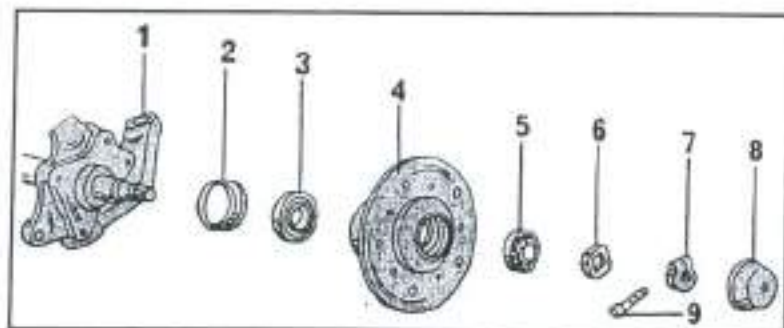

Fig. 4.15 - The component parts of a front wheel hub.

- | | |
|------------------------|------------------|
| 1 Axle beam | 6 Thrust washer |
| 2 Oil seal | 7 Clamp nut |
| 3 Taper roller bearing | 8 Hub grease cap |
| 4 Wheel hub | 9 Clamp bolt |
| 5 Taper roller bearing | |

- Smear the bearings with approx. 50 grams of bearing grease. This must be evenly distributed between the bearings and the inside of the hub (per hub). First fill the spaces between the inner bearing with the grease, insert the bearing and smear some more grease into the end faces of the rollers. Fill the oil seal between the seal lip and the dust lip with grease and carefully drive the oil seal into the rear of the hub, until the outer face is flush. Do not damage the seal.
- Smear the remaining grease into the outer wheel bearing and the inside of the hub (approx. 15 grams) and refit the wheel hub as described in the last section. Never use more grease than specified, as this will be pushed out.
- Adjust the wheel bearing clearance as described in Section 4.2. Make sure the clearance is adjusted correctly.

4.4 Steering Knuckle - Removal and Installation

Steering knuckles can only be removed after removal of the complete front axle, as the axle must be placed under a press, to press out the king pin. The relevant operations are described in Section 4.1.1. Read through the section before proceeding, as the ends of the axle beam must be heated-up to remove a steering knuckle

4.5 Front Wheel Alignment

Only the toe-in setting should be checked. Castor and camber setting checks should be carried out at a dealer. The camber cannot be adjusted. The adjustment of the castor setting is carried out by means of wedges which are inserted in pairs between the front axle beam and the two springs. The wedges must be inserted with the smaller ends in direction shock absorber.

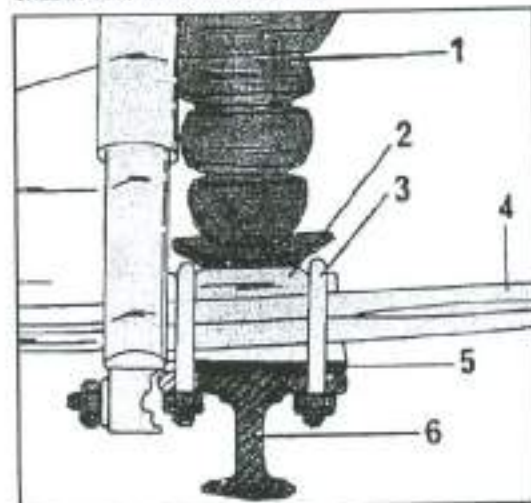

Fig. 4.16 - Sectional view of the spring mounting with the position of the adjusting wedge for the castor angle.

- | |
|-------------------|
| 1 Rebound rubber |
| 2 Spring plate |
| 3 Spring "U" bolt |
| 4 Leaf spring |
| 5 Adjusting wedge |
| 6 Axle beam |

Wedges are available in 5 sizes, i.e. your dealer will be in a position to select the correct wedges, if the castor setting must be corrected.

This is one reason that you will not be able to adjust the castor under D.I.Y. conditions. Fig. 4.16 shows a sectional view of the front

axle on one side, with the position of adjusting wedge.

4.5.1 Toe-in Adjustment

Toe-in is the difference in the distance between the front of the front wheels and the rear of the front wheels, measured at the wheel rims and in the height of the wheel hubs, when the front wheels are in the straight-ahead position. The dimension should be 2 mm, with a tolerance of plus or minus 1 mm, i.e. the distance at the rear should be greater.

Excessive toe-in of the front wheels can be recognised on wear on the outside of the tyres. Wear on the inside of the tyres points to excessive toe-out, also called negative toe-in.

The toe-in can only be checked properly with the correct equipment, i.e. a good tracking gauge must be available. Otherwise have the geometry checked by a specialist workshop. Proceed as follows:

- Turn the steering into the centre position.
- Place the tracking gauge against the front of the wheel rims, in height with the wheel hubs and set the gauge to zero. Mark the points where the gauge is applied with chalk.
- Push the vehicle forward by half a turn of the wheels until the two points marked with chalk are at the rear of the wheels, again at the same height as the hubs. Apply the tracking gauge to the rear of the wheel rims and read off the value. This should be within the values given above. If this is the case, there is no need to carry out any adjustments. Otherwise adjust the toe-in to 2 mm.
- If the setting is outside the value given, adjust the toe-in by altering the length of the track rods after slackening of the track rod clamps. Before tightening of the track rods, push both track rod ball joints against their stops. After tightening the clamps check that both track rod ball joints can be moved to and fro.
- Re-check the toe-in setting as described above and lighten the clamps.

4.6. Front Axle – Tightening Torques

Steering drag link to steering lever	9.0 – 10.0 kgm
Spring "U" bolt nuts	8.0 kgm
Stabiliser bar to front axle	3.0 kgm
Track rod ball joint nuts	3.5 kgm
Shock absorber mountings	7.0 kgm
Wheels	16 – 18 kgm
Brake caliper to steering knuckle	19 – 20 kgm
Brake disc to wheel hub	10.5 – 12.5 kgm
Wheel hub clamp bolt	1.2 kgm
Brake disc splash shield	1.0 kgm

5 Rear Axle and Propeller Shaft

5.0 Technical Data

Type	Rigid axle with leaf springs, hydraulic telescopic shock absorbers and stabiliser bar (anti-roll bar)
------	---

Oil Capacity of Rear Axle:

- Axle number 741.400 and 741.401	1.6 litres
- Axle number 741.404 and 741.405	1.8 litres
- Axle number 741.5 (twin wheels)	1.8 litres
Type of oil	Hypoid gear oil SAE 90 or 85W/90

Rear spring part number	Depending on model version
Shock absorber part number	Depending on model version
Wheel bearing clearance	0.02 – 0.4 mm (only with twin wheels)

Depending on the vehicle, an axle with a single wheel on each side (types HL 0/1 or HL 0/2) or with twin wheels (type HL 03) is fitted to the model range covered in this manual. The arrangement of the suspension is, however, the same for all axles, i.e. leaf springs and telescopic shock absorbers are used.

5.1 Axle with two Wheels

5.1.1 Removal and Installation of Rear Axle

A solid strong mobile jack is required to remove the rear axle. A helper is also required to guide the axle during removal and installation. Proceed as follows to remove the axle:

- Remove the wheel covers and slacken the wheel nuts.
- Place the rear end of the vehicle on chassis stands. In this case the stands must not be placed underneath the axle. Fig. 5.1 shows various positions where the stands can be placed.
- Below the vehicle remove the two handbrake cables after unscrewing the nuts in the centre of the compensating lever and disengaging the spring.
- Pull out the spring clips on the handbrake cable intermediate bearing, unscrew the securing clips for the handbrake cables on the frame sidemember and pull the handbrake cables out of the guide plates.
- Unscrew both shock absorbers from the rear axle. The axle must be lifted until the shock absorbers are slightly compressed.

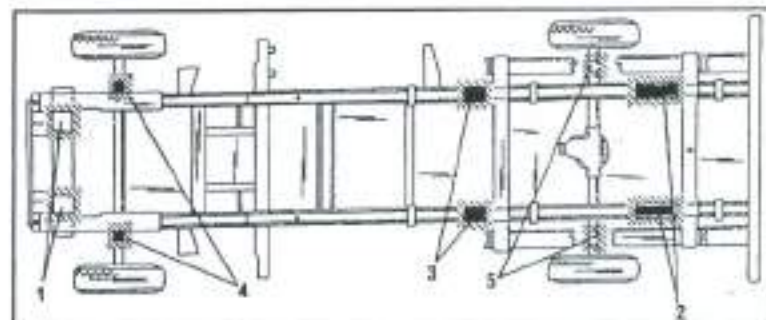

Fig. 5.1 – View of the chassis from underneath. 1 to 5 show where chassis stands can be placed under the vehicle.

- Above the rear axle disconnect the brake pressure regulator linkage, using a screwdriver as shown in Fig. 5.2.

Fig. 5.2 - The brake pressure regulator linkage is separated at the upper ball joint (screwdriver).

- Unscrew the brake hose-to-brake pipe connection. Counterhold the hexagon of the hose with an open-ended spanner when slackening the pipe union nut. Knock out the spring plate and withdraw the hose.
- Disconnect the propeller shaft flange from the rear axle flange. Note that the shaft will drop when the last bolt is removed. Take care.

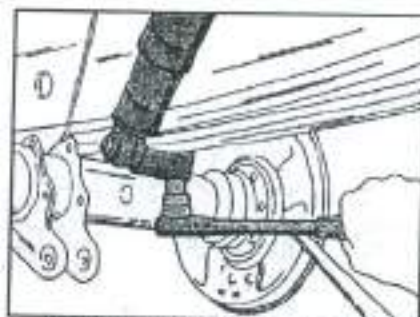
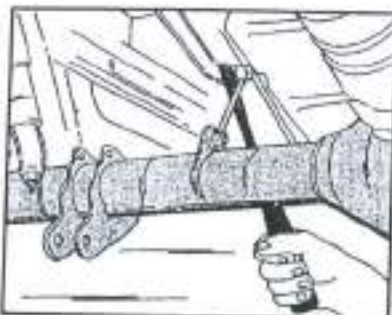

Fig. 5.3 - Removal or installation of the spring "U" bolts. The nuts are located at the bottom of the springs.

- Remove the spring "U" bolt nuts from below the axle (Fig. 5.3) and remove the spring plates. A helper should guide the axle on the jack, to prevent it from tilting to one side.
- Slowly lower the axle on the jack and wheel it out of position.

The installation is carried out as follows:

- Wheel the rear axle underneath the

vehicle, approximately between the centres of the rear springs.

- Lift the axle in position. The centre bolts of the two springs must engage into the locating holes in the axle plates. When engagement has taken place, lift the axle further until it is in full contact with both springs.
- Fit the spring plates and drive in the "U" bolts without damaging the threads. "U" bolts can be bent in a vice to make them fit, if necessary.

Fig. 5.4 - Disconnecting the brake pipe from the brake hose connections.

- Fit the nuts and evenly tighten them to 8.0 kgm (58 ft.lb.).
- Refit the brake hose to the retaining bracket, connect the brake pipe to the hose and tighten the union nut. Counterhold the hexagon as shown in Fig. 5.4.
- Refit the stabiliser bar (2.5 kgm/18 ft.lb.).
- Re-connect the brake pressure regulator linkage.
- Re-connect both shock absorbers. Tighten the nuts to 8.0 kgm (58 ft.lb.).

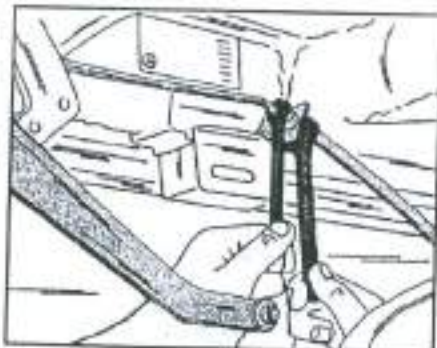

- Re-connect the propeller shaft to the rear axle flange.
- Insert the two handbrake cables into the guide plates and secure with the spring clips. Screw the retaining clips to the frame sidemembers.
- Re-connect the handbrake cables to the compensating lever. The cables must be adjusted as described in Section "Brakes". If the rear brakes have manual adjustment, adjust the brake shoes. Finally bleed the brake system.
- Check the oil level in the rear axle and if necessary correct. Refill the axle with oil, if it has been drained.
- Refit the wheels, lower the vehicle to the ground and tighten the wheel nuts. Finally refit the wheel covers.

5.1.2. Axle Shafts - Removal and Installation

The wheel must be removed, the vehicle must be resting on chassis stands. Proceed as follows:

- Remove the brake drum securing screw and remove the drum.
- Disconnect the return spring for the brake adjuster at the bottom of the brake shoe. A special tool is used in the workshop, i.e. you will have to use a suitable pair of pliers.
- Unscrew the securing nuts for the bearing cover through the holes in the drive shaft flange. The shaft must be turned in order to reach all nuts. Make a note of the fitting direction of the nuts, as the new nuts (must always be replaced, see below) must be fitted the same way round. Carefully withdraw the shaft. After removal mark the shaft in accordance with the side of the vehicle, if both shafts are to be removed. A fitted compression ring determines the installation.
- Remove the gasket and the brake back plate. Sometimes the outer race of the taper roller bearing will remain in the axle tube. In this case a suitable puller must be used to remove it.

Refit an axle shaft as follows:

- Fit the brake carrier plate to the rear axle and insert the gasket between the bearing cover and the brake back plate. Make sure that the "O" sealing ring is fitted to the supporting ring of the rear axle shaft.
- Insert the rear axle shaft in accordance with the marking, but refer to the following note:

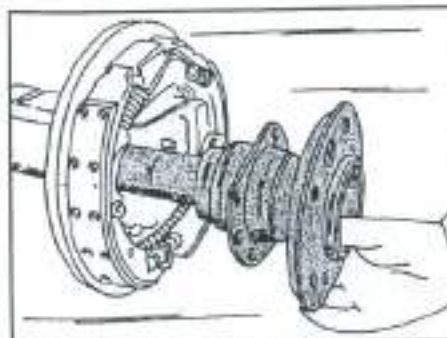

Fig. 5.5 - Fitting an axle drive shaft.

Note: Up to a certain chassis number the rear axle shaft bearing is secured with a shrink ring. The shaft has been modified later on and a locking plate and a slotted nut is used. Only fit the later version, if a shaft has been replaced. The new shafts are marked with two arrows in the shaft flange, indicating the direction of rotation - i.e. make sure that the shaft is fitted to the correct side. If wrongly installed, the slotted nut may come loose and major

axle damage can take place.

- Align the holes in the bearing cover with the holes in the brake backplate and the rear axle tube (Fig. 5.5) and fit and handtighten the bolts. The nuts are self-locking and must always be replaced. Tighten the nuts evenly across, until the bolt heads contact the bearing cover and the cover contacts the brake backplate. From this position tighten each nut by a further $\frac{1}{8}$ of a turn, until the correct tightening torque of 7.7 – 8.8 kgm (55 – 63.5 ft.lb.) has been obtained. Again the shaft flange must be rotated accordingly to insert a socket with a short extension.
- Engage the return spring with the brake adjuster, refit the brake drum and fit the securing screw. All other operations are carried out in reverse order to the removal procedure.

5.1.3. Axle Shaft Repairs

If a shrink ring is used to retain the shaft bearing, take the shaft to a workshop to have the bearing replaced. You will find that the overhauled axle shaft will have a slotted nut with locking plate, as the workshop will have converted it to the later version.

If a slotted nut is used to secure the bearing it will be possible to replace the bearing, but as a special wrench is required to obtain the high torque setting for the slotted nut (tool number 480 589 01 07 00) and a special puller to withdraw the bearing off the shaft, we also advise you to have the bearing replacement carried out in a workshop.

In both cases the axle shaft will be ready for installation as described above.

5.1.4. Rear Axle Overhaul

Many special tools and experience are necessary to overhaul the rear axle and the differential. To check the axle drive you can unscrew the rear cover (oil drained) and check the condition of the crown wheel and other parts for major damage.

5.2 Rear Axle with four Wheels

5.2.1. Removal and Installation of Axle

The removal and installation of the rear axle is carried out in the same manner as described for the other axles. Differences in the torque settings of some parts must be observed. These are listed in the tightening torque table at the end of this Chapter.

5.2.2. Brake Drums/Wheel Hubs – Removal and Installation

A peg spanner is required to remove the large slotted nut for the brake drum from the axle tube. Although it may be possible to remove the nut, but it will be difficult to tighten the nut to the high torque setting during installation of the drum. The special wrench has the number 319 589 01 07 00. There are two nuts used on the drum/hub, but only the other one is very tight. The inner nut is used to adjust the wheel bearing play. Provided you can obtain the above wrench and can obtain a dial gauge, proceed as follows:

- Unscrew the nuts on the outside of the brake drum and withdraw the axle drive shaft.
- Using a small chisel and knock back the "ear" of the locking plate from one of the slots in the nut. The special wrench is now applied as shown in Fig. 5.6 to

slacken and remove the nut. Lift off the locking plate and remove the inner nut with the wrench.

Fig. 5.6 – Slackening (or tightening) of the wheel bearing nuts with the special peg spanner.

- Remove the thrust washer placed over the bearing. The washer has a lug which is inserted into a slot in the axle tube, to prevent it from rotation.
- Remove the brake drum with one hand, at the same time catching the outer wheel bearing, as shown in Fig. 5.7. If the drum is difficult to remove, release the brake adjusting mechanism inside the brake drum as described in Chapter "Brakes",

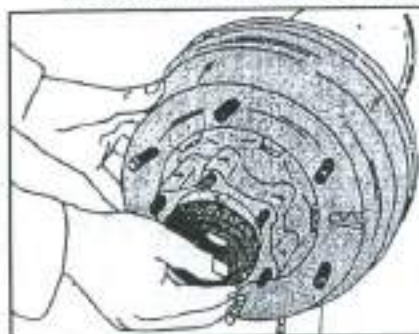
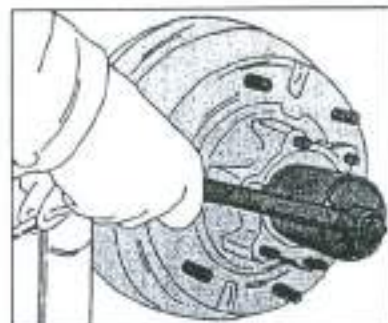

Fig. 5.7 – Removal of a brake drum together with the outer wheel bearing.

- Check the thrust ring for scoring marks. If it must be removed, use a cold chisel and split it as shown in Fig. 5.8.
- If the wheel bearings are to be replaced, refer to the next section.

Fig. 5.8 – The thrust ring on the axle tube must be removed as shown.

The installation is carried out as follows:

- If the thrust ring has been removed, heat it to approx. 80° C and slide it over the axle tube (use leather gloves). Fit the brake drum over the tube.
- Generously grease the outer wheel bearing with bearing grease and drive it in position, using a suitable piece of tube.
- Fit the thrust washer, with the lug engaging with the slot in the axle tube and push it against the bearing.
- Fit the inner wheel bearing nut and using the special wrench, tighten it to 30 kgm (215 ft.lb.). Rotate the drum as you tighten the nut to settle the bearings. After the torque has been reached, slacken the nut and then tighten it until it is just in contact with the thrust washer. From this position slacken the nut by $\frac{1}{8}$ of a turn.
- Fit the locking plate and the outer wheel nut. Tighten the nut to 20 – 25 kgm (144 – 180 ft.lb.).

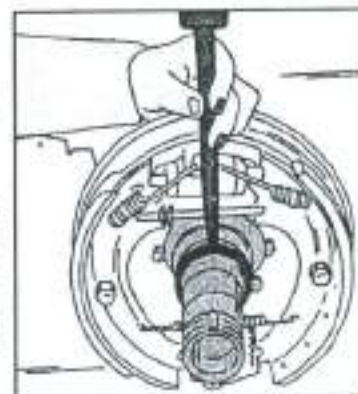
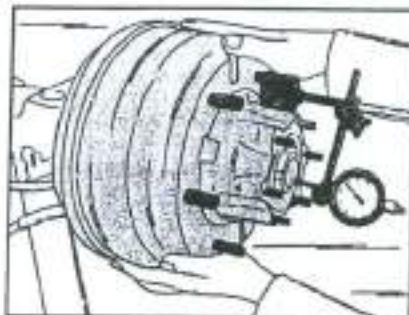

Fig. 5.9 – Checking the wheel bearing clearance. The drum is moved to and fro.

- Fit a dial gauge with a suitable bracket to the brake drum as shown in Fig. 5.9, with the stylus resting against the brake drum face. Pull the brake drum in and out and observe the dial gauge indication, which should be between 0.02 – 0.04 mm. If necessary, re-adjust the wheel bearing clearance by tightening or slackening the inner nut (adjusting nut).
- Re-check the bearing clearance and fit the lock plate, with one of the lugs opposite one of the nut slots of the outer nut. You will have to find a suitable slot where the lug will fit. Use a small drift and knock the lock plate lug into the nut slot.
- Coat the outer cover with sealing compound and insert the axle shaft into the rear axle tube, engaging the splines. Fit and insert the cover bolts and tighten them evenly across to 6.0 – 7.0 kgm (43.5 – 50.5 ft. lb.).
- Fit the wheels, lower the vehicle to the ground and tighten the wheel nuts.



5.2.3 Wheel Bearing Replacement

Fig. 5.10 shows the component parts of the wheel bearings on one side. The bearings can be replaced as follows:

- Place the brake drum with the inner face over a vice. Use a small drift, inserted through the two bores at opposite ends and knock out the drip plate from the inside of the drum.
- From the outside of the drum drive out the inner wheel bearing and the oil seal, using a thin drift. Apply the drift at different points around the circumference of the bearing. After removal of bearing and oil seal, drive out the bearing race. Two grooves in the drum allow you to apply the drift.

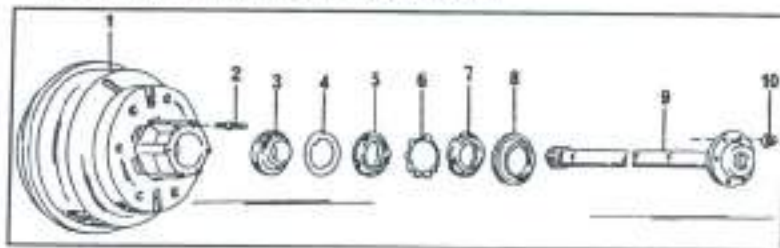

Fig. 5.10 – the parts on the outside of a brake drum.

- | | |
|-------------------------|--------------------|
| 1 Brake drum | 6 Lock plate |
| 2 Wheel stud | 7 Bearing locknut |
| 3 Outer wheel bearing | 8 Oil seal |
| 4 Thrust washer | 9 Axle drive shaft |
| 5 Bearing adjusting nut | 10 Nut |

- Place the brake drum onto the outer face and remove the taper roller bearing outer race from the inside of the drum (small drift).
- If one of the wheel studs is damaged, you can drive them out from the outside.

Only replace wheel bearings in pairs. Also note that both bearings must be from the same manufacturer. If the original bearings are fitted, i.e. the bearing outer races are left in the drums, make sure they are fitted to the original side.

The installation of the bearings is carried out as follows. Note that a quantity of 90 grams of wheel bearing grease is required for each drum:

Fig. 5.11 – Fitting the inner taper roller bearing into the brake drum.

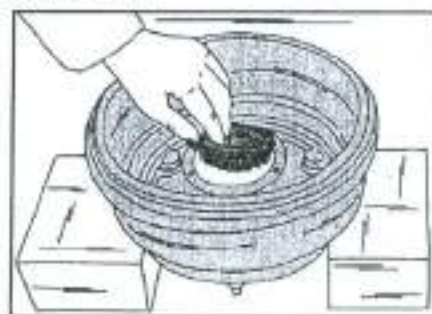

- If removed, drive new wheel bolts into the drum. The drum can be placed onto two wooden planks to ensure unobstructed installation.
- Fit the outer race of the inner wheel bearing into the drum, using a suitable drift, applied against the outer edge. Make sure the race is driven in position without tilting.
- Grease the inner wheel bearing and insert it into the brake drum, as shown in Fig. 5.11 and coat the outside of the bearing with grease. Coat the grease seal lip and smear the outside of the seal with sealing compound. Drive the seal in position until the outside is flush with the brake drum face. Do not damage the seal during installation.
- Smear the remaining grease into the inside of the brake drum.
- Coat the oil drip plate on the outer circumference with sealing compound and fit it to the inside of the brake drum.
- Place the brake drum onto the inner face and fit the outer race of the outer wheel bearing into the drum, using a suitable mandrel.
- The brake drum can now be installed, as described in the last section.

5.3 Rear Axle Oil Level Check and Oil Change

An oil level check plug is fitted into the rear cover of the axle drive. A 14 mm Allen head key is required to remove the plug. The surrounding area of the plug must be cleaned before the plug is unscrewed. The oil level in the rear axle is correct, when the oil can be seen on the lower edge of the filler hole. If necessary top-up with SAE 90 or 85W90 hypoid oil. The plug is tightened to 8.0 – 10.0 kgm (57.5 – 72 ft. lb.).

To change the rear axle oil proceed as follows:

- Drive the vehicle for a few miles to warm up the oil in the axle.
- Place the rear end of the vehicle on chassis stands and unscrew the drain plug at the position shown in Fig. 5.12, using the Allen key mentioned above. Again the area around the plug must be thoroughly cleaned. Take care if the oil is hot, as it will spit out immediately.
- Clean the cover of the axle drive and unscrew the level/filler plug (1) in Fig. 5.12.

- Clean the drain plug and fit it (maybe with a new sealing ring) into the axle. Tighten it to 8.0 – 10.0 kgm (47.5 – 72 ft.lb.).

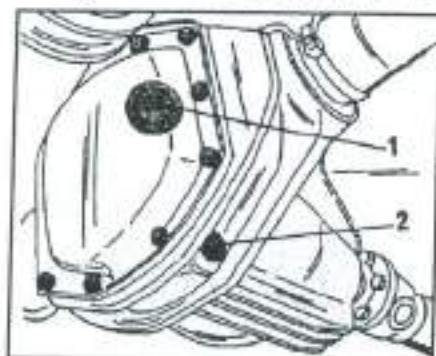

Fig. 5.12 – The location of the oil level filler plug (1) and the oil drain plug (2).

- Fill the rear axle with the specified oil and the quantity given in Section 5.0, depending on the axle type. The oil must be level with the lower edge of the filler bore.
- Clean the filler plug and fit and tighten it to the torque given above.

5.4 Propeller Shaft

The removal and installation of the propeller shaft is straight forward. The shaft is attached at each end to flanges on the gearbox and the rear axle respectively.

Propeller shafts are normally not overhauled, but your MB dealer may be able to advise you if the universal joint bearings can be replaced.

5.5 Rear Axle – Tightening Torques

Shock absorbers, top and bottom	8.0 kgm
Stabiliser mounting bearings:	
- Axle with two wheels	2.5 kgm
- Axle with four wheels	5.0 kgm
Spring "U" bolt nuts	8.0 kgm
Wheel nuts	16.0 – 18.0 kgm
Axle drive shaft cover to axle tube	7.7 – 8.8 kgm
Slotted nut for axle shaft	20 – 24 kgm
Axle shaft (with twin wheels)	6.0 – 7.0 kgm
Slotted nut for brake drums	20 – 25 kgm
Cover to rear axle housing	4.0 – 5.0 kgm
Oil filler and drain plug	8.0 – 10.0 kgm

6 Front and Rear Suspension

Front axle and rear axle are fitted with leaf springs. Both axles have a stabiliser bar. The following instructions are valid in general for both axles.

6.1 Replacing a Leaf Spring

- Jack up the vehicle end in question and place stands underneath the chassis in accordance with Fig. 5.1. Remove the wheel.
- When removing a rear spring, detach the two handbrake cables from the centre of the compensating lever and disconnect the return spring.
- Remove the spring plates for the handbrake cable attachment on the centre bracket and the retaining clamps from the sidemembers and withdraw the cables from their guides (only in the case of a rear spring).
- Disconnect the shock absorber from the lower mounting. The axle must be lifted slightly to compress the dampers.
- In the case of the rear axle disconnect the brake pressure regulator linkage (see Fig. 5.2).
- Disconnect the brake pipes from the brake hose as described in the last chapter (see also Fig. 5.4 (rear axle only)).
- Unscrew the stabiliser bar from the axle.
- Remove the nuts from the spring "U" bolts and remove the spring plates (refer to last chapter, "Removal of the Rear Axle").
- Slowly lower the axle on the jack until it is free of the leaf spring. Note the position for the castor adjusting wedge, if a front axle is removed.
- Remove the spring mountings at the front and the rear and take out the spring. A helper may here be useful.

If one of the leaves has broken, enquire at a MB dealer if it can be replaced; otherwise replace the complete spring.

The installation is a reversal of the removal procedure. Chapters 4 and 5 give specific details for the installation of the axle in question.

6.2 Shock Absorbers

Shock absorbers are secured with bolts and nuts at the upper and lower mountings. The axle must be lifted until the shock absorber is slightly compressed, when a shock absorber is removed. The lower mounting of a front shock absorber has a spacer bush and a washer between the mounting eye and the axle beam.

To check a shock absorber, clamp it vertically into a vice and "pump" it up and down. The shock absorber should show even resistance throughout the travel. "Dead" travel requires the replacement of the damper unit.

The installation is a reversal of the removal procedure. The tightening torques are given at the end of Chapters 4 and 5.

6.3 Stabiliser Bar

The stabiliser bar is bolted to the axle and the chassis. The removal and installation of the bar can be accomplished with the vehicle resting on chassis stands. Otherwise remove the wheels (front or rear). The stands can be placed underneath the front axle beam or the rear axle tubes.

When fitting the stabiliser bar observe the tightening torques. Different torques apply to the rear axle, depending if two or four wheels are fitted. The bolt of the front stabiliser is tightened to 3.0 kgm (22 ft.lb.). New rubber bushes must be fitted.

Refit and tighten the wheels, if they have been removed. In this case observe the tightening torque for the wheel nuts.

7 Steering

7.0 Technical Data

Type	Recirculating ball steering. With power-assisted steering (optional or standard)
Max. speed of steering pump	7000 rpm
Pump pressure	max. 5 bar
Pressure relief valve opens at	65 bar, plus or minus 5 bar
Oil capacity of mechanical steering	450 ccm
Fluid capacity of power-assisted steering	1.6 litre
Type of fluid used	As in automatic transmissions
Fluid used	MB steering fluid

6.1 Mechanical Steering

6.1.1 Removal and Installation

Suitable ball joint pullers to separate the ball joints from the steering linkage and the steering drop arm from the steering shaft must be available to remove the steering:

Fig. 6.1 - Raised engine bonnet (1) and vehicle front end (2). The strut (3) is used to retain the parts in position.

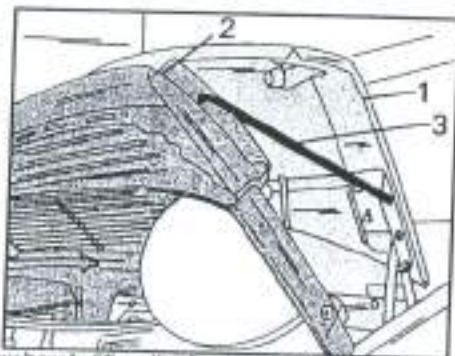

- Open the bonnet and disconnect the battery.
- Remove the bolts attaching the front end flap at the top to the side panelling and unscrew at the bottom. Unscrew the radiator strut at the radiator and prop up the front end flap and secure it with a self-made strut, as shown in Fig. 6.1. We assume, however, that you will know how to lift up the front end of the van.
- Set the front wheels in the straight-ahead position, steering wheel spokes horizontally aligned.
- Slide up the protective gaiter around the universal joint on the steering column connection and slacken and remove the joint clamp bolt.
- Unscrew the drop arm nut. The drop arm is the lever connected to the steering shaft. Use a suitable puller to withdraw the arm. The pressure spindle must press against the steering shaft, the claws of the puller must engage below the arm.

- Unscrew the steering and the mounting bracket from the chassis sidemember and remove the complete assembly, at the same time disengaging the steering shaft from the universal joint. Remove the steering unit from the bracket, if a new steering is to be fitted.

The installation of the steering is a reversal of the removal procedure. Note the following points:

- If the steering has been replaced, fit it to the mounting bracket and tighten the bolts to 4.0 - 5.0 kgm (29 - 36 ft.lb.).
- Position the steering with the mounting bracket against the sidemember, at the same time engaging the end of the steering shaft with the universal joint. It is assumed that the front wheels and the steering wheel are still in the straight-ahead position. Tighten the mounting bracket bolts to 4.0 - 4.5 kgm (29 - 32.5 ft.lb.) and the universal clamp bolt to 3.2 - 3.5 kgm (23 - 25 ft.lb.). Finally fit the gaiter over the universal joint.
- Push the steering drop arm over the steering shaft. Drop arm and steering shafts are marked. The marks must be opposite each other as shown in Fig. 6.2 after the arm has been fitted. Fit the nut and tighten to 20 - 22 kgm (144 - 158 ft.lb.).

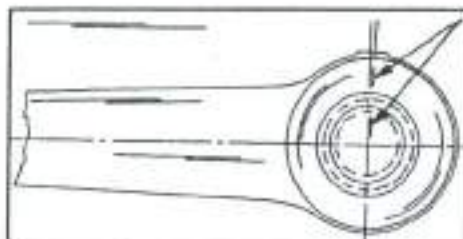

Fig. 6.2 - Drop arm and steering shaft are marked as shown and must be fitted accordingly.

- Turn the steering wheel from one lock to the other and check that the stop screw on each side contacts the front axle beam. If this is not the case, check the drop arm alignment once more and refit it correctly.
- All other operations are carried out in reverse order. Check the oil level in the steering box as described in Section 6.4. After completed installation take the van on the road and check if the steering wheel spokes are correctly aligned. If necessary remove the steering wheel (puller required) and refit it accordingly.

6.1.2 Steering Linkage

Only the steering drop arm, also known as pitman arm, a steering drag link and a track rod are used to transmit the movement from the steering. The connection between the drop arm on the steering box and the steering lever on the steering knuckle is by means of the steering drag link. On the other side of the steering lever you will find the ball joint connection of the track rod, which is connected to the steering knuckle on the opposite side. All connections of the steering drag link and the track rod use ball joints, secured by castellated nuts and split pins.

Ball joint studs are separated with a suitable ball joint puller. The following text describes in more detail the replacement of some of the parts.

Steering Drop Arm

Open the bonnet and lift up the front end of the vehicle and secure in the lifted position.

- Remove the castellated nut securing the steering drag link to the drop arm and separate the ball joint stud from the end of the drop arm.
- Unscrew the drop arm nut and using a two-arm puller, withdraw the arm from the end of the steering shaft. Drop arm and steering shaft end are marked.

It is, however, sometimes difficult to see the marking and we therefore suggest to mark the fitted lever and the steering box housing with a spot of paint to facilitate the installation (provided there is no need to turn the steering shaft). Otherwise you will need a small mirror when fitting the drop arm. Note that the drop arm is not the same on all vehicles. If replacement is necessary, quote the model and the chassis number.

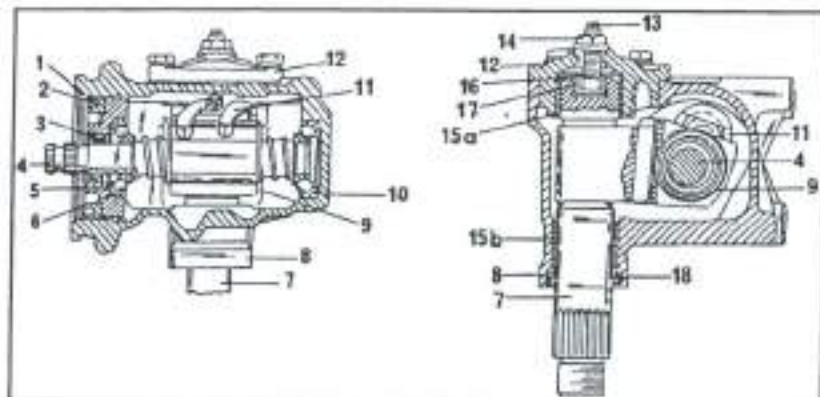

Fig. 6.3 - Sectional view of the mechanical steering.

1 Securing ring	7 Drop arm shaft	13 Adjusting screw
2 Threaded ring	8 Steering box housing	14 Locknut
3 Oil seal	9 Steering nut	15 Bearing bush
4 Steering worm	10 Taper roller bearing	16 Securing ring
5 Adjusting ring	11 Ball guide	17 Spacer washer
6 Taper roller bearing	12 Housing cover	18 Oil seal

- Check the drag link ball joint rubber caps. If they have been damaged during the joint separation, replace them, if the damage is of an earlier nature, replace the ball joint as described below.
- Thoroughly clean the splines on the inside of the steering drop arm and the outside of the drop arm shaft from oil or grease.
- Place the steering drop arm over the shaft, observing the alignment marks and fit and tighten the nut. Use a socket and a torque wrench and tighten the nut to 20 – 22 kgm (144 – 158 ft.lb.).
- Re-connect the steering drag rod, tighten the castellated nut to 7.0 – 10.0 kgm (50.5 – 72 ft.lb.) and fit a new split pin.

Steering Track Rod

- Withdraw the split pins from the castellated nuts on both ends of the track rod and using a suitable puller, as shown in Fig. 6.4, remove the ball joint studs on both ends of the track rod. The track rod can now be removed.
- Check the rubber dust caps in the same manner as explained for the drag link.

The installation is carried out in reverse. Tighten the castellated nuts to 7.0 – 10.0 kgm (50.5 – 72 ft.lb.) and fit new split pins. Check the front wheel toe-in after installation of a new track rod.

Fig. 6.4 - Removal of the steering drop arm with the special puller, shown on the connection between drop link and drop arm.

- | | |
|---|--------------------|
| 1 | Steering drop arm |
| 2 | Puller |
| 3 | Steering drag link |

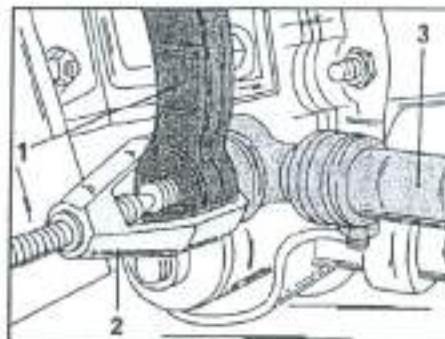

6.2. Power-assisted Steering

Before it is decided to remove the power-assisted steering due to loss of pressure, we advise you to have the pressure checked in a workshop, as special equipment is required. The following notes will give you some advice when dealing with the steering:

- Originally a steering type "LS2" is fitted. You will find this steering type in models 208D and 308D.
- A modified steering was fitted to later models and has now the type identification "LS2 A". This steering is now fitted to all models covered in the manual.
- The steering type is important when a new unit or a second-hand unit is fitted.
- The power-assisted steering can be overhauled, but the work must be left to a workshop. Fig. 6.5 shows a sectional view of the steering for reference.

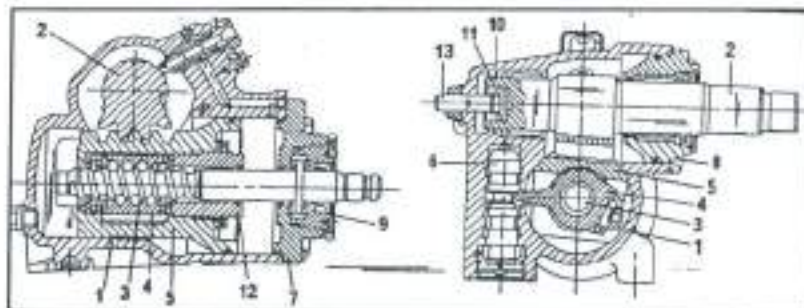

Fig. 6.5 - Sectional view of the power-assisted steering.

1 Steering box housing	6 Regulating valve	11 "O" sealing ring
2 Steering drop arm shaft	7 Bearing cover	12 Screw cover
3 Steering worm	8 Housing cover	13 Adjusting screw
4 Steering nut	9 Bearing insert	
5 Piston	10 Sealing ring	

6.2.1. Removal and Installation

- Jack up the front end of the vehicle and place chassis stands underneath the front axle beam.

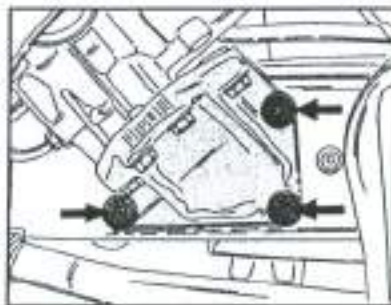

Fig. 6.6 - The pressure pipe (1) and the return pipe (2) are connected as shown. The plug (3) can be removed to drain the steering.

- Open the fluid reservoir and remove the filter insert. Using a syringe, remove the fluid from the container. The system can also be drained by opening the plug next to the two hydraulic pipes in Fig. 6.6. In this case start the engine and let it run for approx. 10 seconds, until pump and reservoir are drained. Catch as much fluid as possible from the draining point.

- Remove the split pin from the drag link nut, remove the nut and separate the ball joint connection in similar manner as shown in Fig. 6.4.
- Refer to Fig. 6.6 and disconnect the high pressure pipe (1) and the return pipe (2). Close the open connections in suitable manner to prevent entry of foreign matter.
- Push the protective gaiter away from the steering shaft connection and remove the universal joint clamp bolt. Push the universal joint with the steering shaft away from the steering worm shaft. Steering shaft and steering worm shaft have marks which must be aligned during assembly.

Fig. 6.7 - The arrows point to the securing bolts for the steering.



- Remove the three bolts shown in Fig. 6.7 on the chassis sidemember and remove the steering unit together with the mounting bracket. If necessary remove the steering from the bracket (tighten the bolts to 4.0 - 5.0 kgm (29 - 36 ft.lb.) during installation).

The installation is carried out as follows:

- Check the markings of the bolt heads (8.8 or 10.9) before installation.
- If separated, fit the steering to the bracket and then position bracket and steering unit to the side member. Tighten the bolts to 8.0 kgm (58 ft.lb.) if the bolt heads are marked with "8.8" or to 10.5 kgm (75 ft.lb.) if the heads are marked with "10.9".
- Re-connect the steering shaft in accordance with the alignment marks to the steering worm shaft, fit the bolt (a groove in the shaft provides positive engagement) and tighten the assembly to 3.5 kgm (25 ft.lb.).
- Check that the steering drop arm and the steering wheel are in the centre position. The steering wheel spokes must be in horizontal position, when the three marks shown in Fig. 6.8 are aligned. When satisfied, fit the protective gaiter over the steering shaft connection.

Fig. 6.8 - Check that the alignment marks are in line when the steering is in the centre position.

- Steering housing
- Steering drop arm shaft
- Steering drop arm

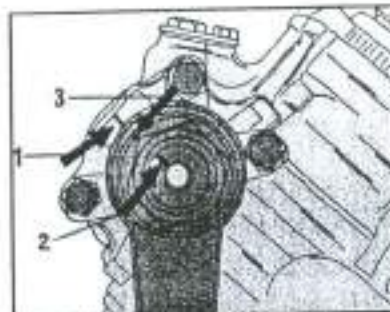

- Fit the drain plug (3) in Fig. 6.6 and tighten to 5.0 - 5.5 kgm (36 - 40 ft.lb.) and refit the two steering fluid pipes.
- Set the front wheels in the straight-ahead position and connect the steering drag link to the steering drop arm, without moving the wheels. Adjust the length of the drag link, if the ball joint stud cannot be inserted.
- Tighten the castellated nut. The tightening torque depends on the thread diameter. Nuts with M14 thread are tightened to 11 kgm (80 ft.lb.), nuts with M16 thread are tightened to 12 - 15 kgm (86 - 106 ft.lb.), nuts with M18 threads to 16.5 - 20.5 kgm (133 - 146 ft.lb.). Tighten the nut a little more, if the split pin cannot be inserted. As the nut must not be slackened, try the split pin insertion before the upper limit of the applicable torque is reached. In this case you will have some scope to tighten the nut further.
- Bleed the steering system as described in the next section.
- Turn the steering from one stop to the other and check if the stop bolts contact the front axle pads on each side.
- Finally check and if necessary adjust the toe-in setting as described in the section dealing with the front suspension.
- Road test the vehicle and check the correct position of the steering wheel spokes. If necessary remove the steering wheel (Section 6.3) and refit it in the correct position. Tighten the nut to 6.0 kgm (43 ft.lb.).

6.2.2. Bleeding the Steering System of Air

The steering system must be bled of air when any of the connections have been opened or air has entered the reservoir due to a low fluid level. The steering system has a capacity of 1.6 litres. Bleed the system as follows, a helper is required:

Fig. 6.9 - The reservoir for the steering fluid is located next to the brake master cylinder.

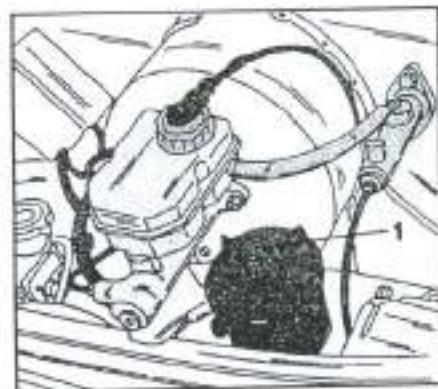

- Place the front end of the vehicle on chassis stands.
- Remove the reservoir cap and take out the filter insert. Fill the reservoir with steering fluid to the "Max" mark.
- Start the engine and turn the steering wheel a few times from one lock to the other. As the fluid level drops, fill more fluid into the reservoir (helper). The system is

self-bleeding, i.e. no further operations are required, important is that the fluid level is always kept above the "Min" mark to prevent fresh air from entering the system. MB recommends Dexron II-D ATF fluid.

- Continue moving the steering wheel until no more air bubbles can be seen in the fluid.
- Fit the filter and the reservoir cap. Unscrew the cap once more and check the fluid level on the dipstick. With the engine running, the fluid level must be seen between the upper and lower mark on the dipstick.

6.3. Steering Wheel

The removal of the steering wheel requires a puller, which can be attached with the extractor bolts to the hub of the steering wheel. After removal of the steering wheel centre and removal of the steering wheel nut, attach the puller in the manner shown in Fig. 6.10 and tighten the centre bolt until the wheel is free.



Fig. 6.10 - Removal of the steering wheel.

Remove the puller and mark the position of the steering wheel on the steering shaft, before it is withdrawn.

The installation is a reversal of the removal procedure. Align the marks made before removal. The nut is tightened to 5.0 kgm (43 ft.lb.).

6.4. Steering Box Oil Level (mechanical steering)

The oil level in the steering box must be checked as part of the regular maintenance. The steering is filled with approx. 0.5 litres of oil.

To check the oil level, remove the plug immediately below the universal joint gaiter. To check the oil level, turn the steering wheel fully to the left.

In this position the oil level should be 35 - 45 mm below the upper edge of the plug bore. To check, either use a torch or insert a piece of wire to reach the oil.

If necessary, top up the steering box with the specified oil, as used by Mercedes-Benz.

6.4. Tightening Torques - Steering

Steering to sidemember	3.5 - 4.5 kgm
Ball joint nuts	7.0 - 10.0 kgm
Steering drop arm nut	20 - 22 kgm
Steering wheel nut	6.0 kgm
Steering drag link ball joint nut (drop arm side):	
- M14 thread	11.0 kgm
- M16 thread	12.0 - 15.0 kgm
- M18 threads	18.5 - 20.5 kgm

7 Brake System

7.0. Technical Data

Type of system	See description below
Effective braking area:	
- Front brakes	300 sq.cm.
- Rear Brakes - Model 601	245 sq.cm.
- Rear brakes - Model 602	450 sq.cm.
- Rear brakes - Model 611	670 sq.cm.
Total braking area:	
- Model 601	545 sq.cm.
- Model 602	750 sq.cm.
- Model 611	970 sq.cm.
Caliper piston diameter, front brakes	44.00 mm
Wheel brake cylinder piston diameter, rear brakes:	
- Models 601 and 602	15.87 mm
- Model 611	22.20 mm

Front Disc Brakes

Thickness of brake pads, incl. back plate	14.0 mm
Min. thickness of linings	2.0 mm
Min. thickness including metal plate	6.0 mm
Brake disc diameter	260.0 mm
Brake Disc Thickness:	
- All models to Feb. 1988	16.0 mm
- Model 611 from Feb. 1988	22.0 mm
Min. Thickness of Brake Discs:	
- All models to Feb. 1988	13.0 mm
- Model 611 from Feb. 1988	19.0 mm
Wear limit of brake discs, per side	max. 0.05 mm

Rear Drum Brakes

Brake drum diameter:	
- Model 601	230.0 mm
- Model 602	260.0 mm
- Model 611	270.0 mm
Max. permissible drum diameter:	
- Model 601	231.0 mm
- Model 602	261.0 mm
- Model 611	271.0 mm
Max. run-out of drum face	0.05 mm
Width of Brake Shoes:	
- Model 601	35.0 mm
- Model 602	55.0 mm
- Model 611	80.0 mm
Thickness of new Brake Linings:	
- Repair stage I	8.5 mm
- Repair stage II	9.0 mm
Min. thickness of brake linings	3.5 mm
Wheel bearing clearance	0.02 - 0.04 mm
Basic adjustment of automatic mechanism	See main text

Brake pad/Brake Shoe Lining Material:	
- Front brake pads	Textar T471 or Jurid 544
- Rear brake shoe linings	Jurid 546, Beral 569 or Textar T017
Brake Master Cylinder	
Cylinder diameter – Models 601 and 602	25.4 mm
Cylinder diameter – Model 611	26.99 mm
Brake Servo Unit	
Diameter – Models 601 and 602	8 or 9 inches
Diameter – Model 611	9 inches
Handbrake	
Brakes must apply	When handbrake lever is pulled 5 notches

7.1 Short Description

All models covered in this manual are fitted with a hydraulic dual-circuit brake with vacuum-operated brake servo unit. Fixed brake calipers with 4 pistons are used for the front wheels, with drum brakes at the rear wheels. There are, however, differences in the layout of the brake system. If the system is fitted to vans and pick-ups, the brake system is laid-out as shown in Fig. 7.1. If the vehicle is used for the transport of persons, the brake circuit is arranged as shown in Fig. 7.2. As the circuit shown in Fig. 7.2 can also be fitted to other models, we will give you the major differences:

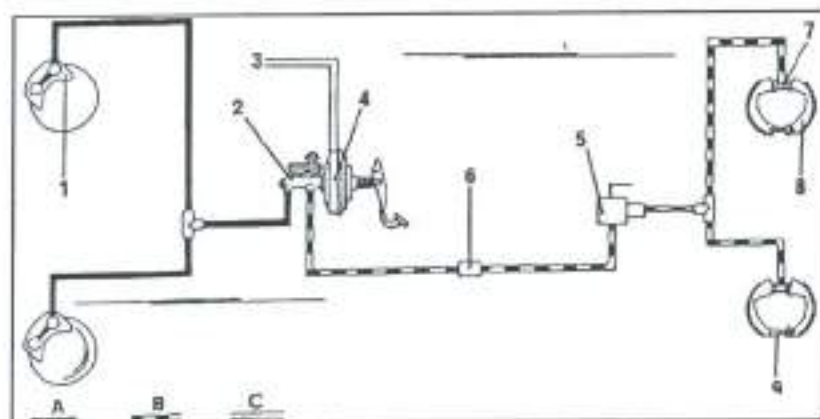

Fig. 7.1 – Brake circuit for delivery vans and pick-ups.

- | | |
|----------------------------|------------------------|
| 1 Fixed caliper | 7 Wheel brake cylinder |
| 2 Tandem brake cylinder | 8 Brake shoes |
| 3 To vacuum pump | 9 Brake adjuster |
| 4 Brake servo unit | A Front brake circuit |
| 5 Brake pressure regulator | B Rear brake circuit |
| 6 Pre-pressure valve | C Vacuum circuit |

- In the circuit arrangement shown in Fig. 7.1, the intermediate piston circuit acts on the front wheels, the push rod circuit on the rear wheels. The four cylinders of each front caliper are interconnected, if the front brakes fail, the rear brakes will operate as normal, but more brake force will be required. The same applies when the rear brakes fail, i.e. the front wheels will work in the normal manner.

- In the circuit arrangement shown in Fig. 7.2, each push rod circuit acts on two cylinders of the front wheel calipers. The intermediate piston circuit acts on the two remaining cylinders of the front calipers and on the rear wheel cylinders.
- If the push rod circuit fails, only half the braking force is applied to the front axle, while the regulated pressure, depending on the load, is fed to the rear axle brakes. If the intermediate circuit fails, the front wheel brakes are only operating with half the brake force.

The front wheels are braked with disc brakes. Fixed calipers with four pistons are used. The rear wheels have drum brakes with manual adjustment or automatic take-up mechanism. Drum brakes with automatic adjustment have a plug at the inside of the brake back plate, marked "Automatik".

All vehicles are fitted with a load-dependent brake pressure regulator which is connected by means of a linkage to the rear axle. A pre-pressure valve (item "6" in the illustrations) retains a fluid pressure of between 0.5 – 1.2 bar after the brakes have been released.

The handbrake acts onto the rear brakes via a system of cables.

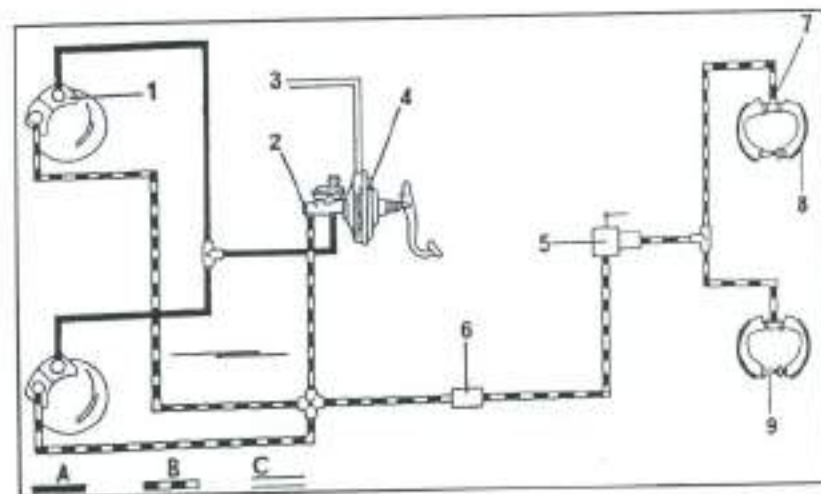

Fig. 7.2 – Brake circuit for models with passenger transport.

- | | |
|----------------------------|------------------------|
| 1 Fixed caliper | 7 Wheel brake cylinder |
| 2 Tandem brake cylinder | 8 Brake shoes |
| 3 To vacuum pump | 9 Brake adjuster |
| 4 Brake servo unit | A Front brake circuit |
| 5 Brake pressure regulator | B Rear brake circuit |
| 6 Pre-pressure valve | C Vacuum circuit |

7.2 Adjusting the Brakes

Only the rear brakes require adjustment, provided that no automatic adjustment mechanism is fitted. The automatic adjustment device is, however, not the same on all models, as assemblies made by Mercedes-Benz or Perrot can be fitted. The operation of the adjusters is also different. The type of mechanism fitted can be recognised on

the inside of the brake back plate, if a Perrot adjuster is fitted, you will find a plug with the inscription "Automatik" in the back plate, if a MB adjuster is fitted, a similar plug is fitted, which has however a slot in the centre.

A special adjusting lever is used to adjust the manually adjusted rear brakes. For the purpose of the description below you will need a larger screwdriver to rotate the adjuster wheels of the brake assemblies. Again the adjusting mechanism can be made by Perrot or MB.

Fig. 7.3 - The bolt retains the adjusting mechanism on the brake back plate, if a Perrot adjuster is fitted. The arrow shows the plug for the adjustment opening.

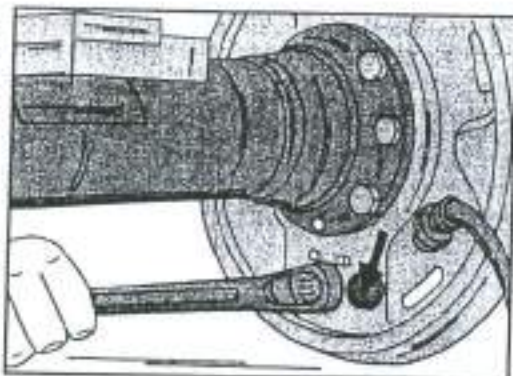

With Perrot Adjusters

- Place the rear end of the vehicle on chassis stands (underneath the axle tubes) and release the handbrake. Undo the adjusting nuts on the ends of the handbrake cables to release the cable tension.
- Slacken the bolt of the adjuster at the rear of the brake back plate, as shown in Fig. 7.3. Slightly tap against the hexagonal bolt to free off the adjuster in the brake back plate. Remove the plug shown by the arrow to allow access to the adjuster wheel.

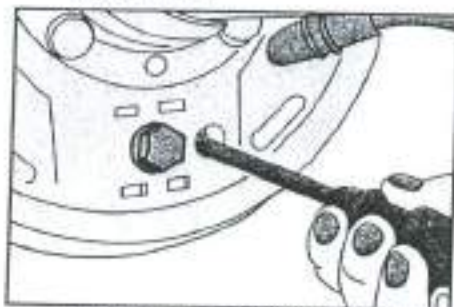

Fig. 7.4 - The screwdriver is inserted into the opening (after removal of the plug) to move the adjusting wheel up or down, depending on the side of the vehicle.

- Insert a screwdriver as shown in Fig. 7.4 between two of the teeth of the adjuster wheel and turn the adjuster until the brake shoes are in firm contact with the brake drum face. In the case of the L.H. brake move the

screwdriver in a downward direction, on the R.H. wheel move the screwdriver blade upwards. After the wheel is locked, tighten the bolt to 4.0 kgm (29 ft.lb.)

- Turn the adjusting wheel on each side back by eight teeth, until the wheel turns freely. Refit the plug.
- Adjust the handbrake as described later on and lower the vehicle to the ground.
- Place the rear end of the vehicle on chassis stands (underneath the axle tubes) and release the handbrake. Undo the adjusting nuts on the ends of the handbrake cables to release the cable tension.
- Turn the plug at the rear of the brake back plate with a large screwdriver by 90° and take out the plug.

Fig. 7.5 - The arrows show where the two brake adjusting wheels are located when MB adjusters are fitted.

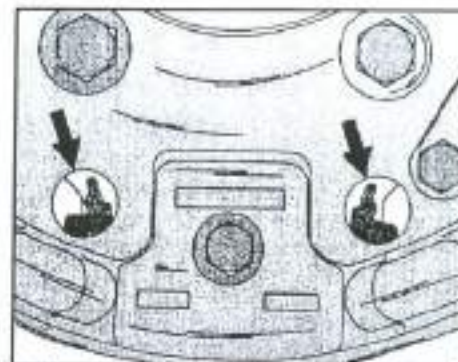

With MB Adjusters

- Referring to Fig. 7.5, first adjust the front and then the rear brake shoe. To do this, insert a screwdriver between two of the teeth of the adjusting wheel. Turn the adjusting wheel (with R.H. thread) until the brake shoe is in contact with the drum surface. From this position turn the adjusting wheels back by 5 teeth. This will give the brake shoe linings a clearance of 0.3 - 0.4 mm. You can measure the gap with a feeler gauge as shown in Fig. 7.6, after removing the plug next to the handbrake cable entry. To check that the adjusting wheel is locked in position, move the wheel by one tooth up and down.



Fig. 7.6 - Checking the clearance between the brake shoe lining and the brake drum surface.

- Check that both wheels can be rotated freely, refit the plug in reverse order, adjust the handbrake and lower the vehicle to the ground.

Note: Brake shoes with automatic take-up device must be adjusted if the brake shoes have been replaced. The operation is described in conjunction with the replacement of the brake shoes.

7.3 Front Disc Brakes

As already mentioned, fixed brake calipers with four pistons are fitted to the front wheels. The assemblies consist of a caliper cylinder bolted rigidly to the front axle.

7.3.0. Brake Pad Replacement

If the remaining brake pad material thickness is less than 2 mm (0.08 in), a warning light will light up in the dashboard, indicating that the brake pads must be replaced. The thickness of the brake pad linings can also be checked through the openings in the brake caliper after the wheels have been removed. Proceed as follows:

- Place the front end of the vehicle on chassis stands (underneath the front axle beam).
- Using a suitable drift, drive out the two retaining pins as shown in Fig. 7.7 from the outside towards the inside. Remove the spring plate.

- Remove the brake pads. Sticking pads can be removed by feeding a wire loop through the holes of the pads and pulling them out with a short pull – *do not cut yourself on the wire!*

Fig. 7.7 – Removal of the brake pad retaining pins.

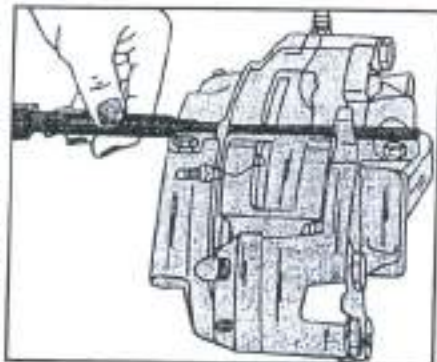

- Carefully push the pistons into their bores, using a piece of hardwood. The fluid reservoir could overflow if necessary remove some brake fluid.
- Check the thickness of the brake pad linings. If it has reached the thickness of approx. 2 matchsticks, replace the pads as a set. Never replace a single pad, even if the remaining three appear to be in good condition.

If brake pads have worn more than expected, there is a possibility that the pistons have seized inside the bores. In this case it may be necessary to overhaul the brake calipers or have them overhauled. The same applies if the rubber dust boots on the cylinder housing are damaged.

Check the brake disc faces and clean them thoroughly before new pads are fitted. If possible measure the brake disc thickness and compare the result with the dimensions given in Section 7.0. If the minimum thickness has been reached, replace the disc(s).

Refit the brake pads as follows:

- Clean the contact areas for the brake pads inside the caliper housing and insert both pads into the caliper.
- Place the spring plate over the brake pads and drive in the retaining pins from the inside towards the outside. The ends of the retaining pins have a clamping sleeve, which must hold the pin securely after installation.
- Check the fluid level in the reservoir and top-up if necessary. Then operate the brake pedal a few times to set the brake pads against the brake disc faces. Re-check and if necessary correct the fluid level once more.
- Treat the new brake pads with care during the first 100 miles or so, remember that the new material must "bed in" before they reach their full performance. To speed up the process, brake the vehicle several times from a speed of approx. 50 mph to 25 mph. Allow the brakes to cool between each braking operation.

7.3.1 Brake Caliper – Removal and Installation

- Push a bleeder hose over one of the bleed screws in the brake calipers and insert the other end of the hose into a jar. Open the bleed screw and operate the brake pedal until the brake fluid has been drained.
- Remove the brake pads as described in the last section.
- Unscrew the union nut from the brake pipe connection on the caliper. Close the open connections in suitable manner to prevent entry of foreign matter.

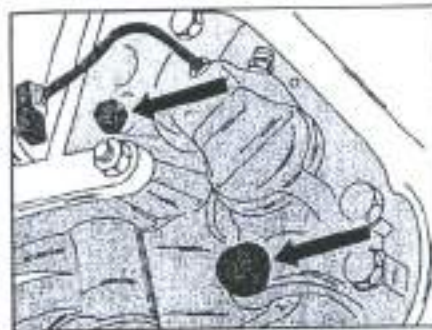

Fig. 7.8 – The two bolts secure the caliper to the front axle.

Unscrew the fitting bolt and the locking bolt, shown with the arrows in Fig. 7.8 and lift off the caliper. The bolts cannot be interchanged, as they have a different diameter.

The installation is carried out in reverse order. Both bolts must be tightened to 19 – 22 kgm (137 – 158 ft.lb.). The brake system must be bled of air after installation.

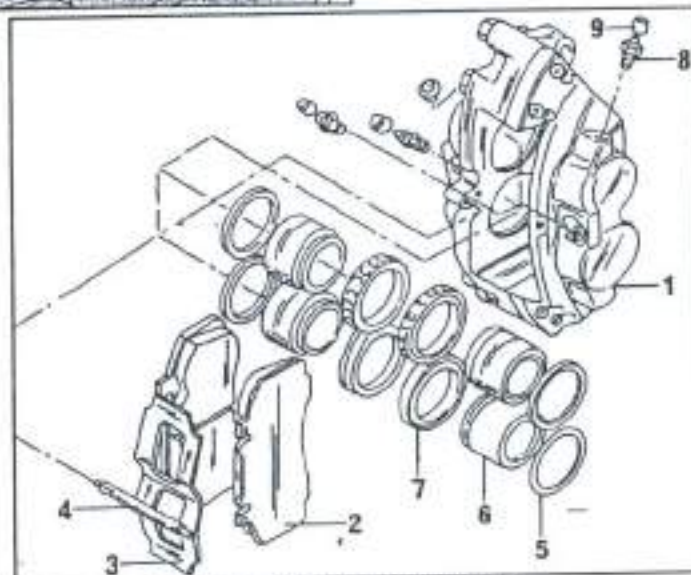

Fig. 7.9 – Exploded view of a brake caliper.

- | | |
|--------------------------|---------------------|
| 1 Brake caliper cylinder | 6 Piston |
| 2 Brake pads | 7 Dust sealing ring |
| 3 Spring plate | 8 Bleed screw |
| 4 Retaining pin | 9 Rubber dust cap |
| 5 Cylinder seal | |

7.3.2 Brake Calipers - Overhaul

Before a brake caliper is dismantled not the following points:

- The two halves of the caliper must not be separated.
- Always replace the cylinder sealing rings after a caliper has been dismantled. These are contained in repair kits.
- Never refit pistons or the caliper if the surfaces show signs of wear, pitting or other damages. In this case fit a new caliper.

- Only use the recommended brake fluid. Never use brake fluid which has been stored for longer periods.
- Pistons and sealing rings must be coated with clean brake fluid or brake paste before installation.

Fig. 7.9 shows an exploded view of a brake caliper. Dismantle a caliper as follows, but first enquire if a repair kit can be obtained:

- Clamp the caliper into a vice and remove the dust seal from cylinder and piston (Fig. 7.10).
- Remove the pistons from the caliper cylinder bores. MB workshops use a special tool for this operation. We recommend to clamp three of the pistons in position and blow out the remaining one with compressed air (applied to the brake hose connection). A piece of wood must be placed into the caliper bore to prevent the piston from hitting the metal. Fingers must be kept away from this area. This method, however, means that each piston must be treated separately.
- Remove the sealing ring out of the cylinder bores as shown in Fig. 7.11, using a blunt instrument.
- Thoroughly clean all parts if the cylinder appears to be in good condition. All parts contained in the repair set must be used.

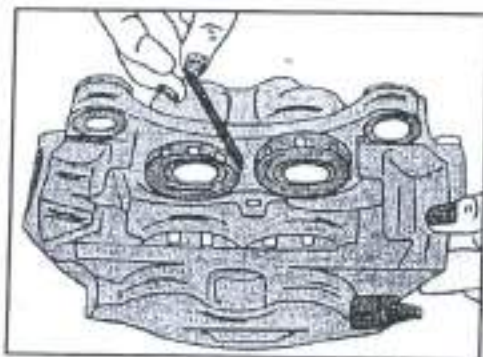

Fig. 7.10 – Remove the rubber dust seals in the manner shown from the end faces of the pistons.

- Coat a new sealing ring with brake fluid or brake paste and insert into the groove in the inside of the caliper.
- Fill the inside of the dust seal with brake paste and attach the seal to the piston.
- Fit the piston with rotating movements into the caliper bore.

Fig. 7.11 – Cylinder sealing rings are lifted out with a small blunt instrument.

- Fit the rubber dust seal over the piston, but note that two pistons must be fitted. To spread the pressure evenly, a pair of pliers, as shown in Fig. 7.12 is most suitable for this operation.
- Thoroughly clean the brake caliper. The caliper and the brake pads can now be refitted. Refer to the instructions in the sections earlier on in this section.

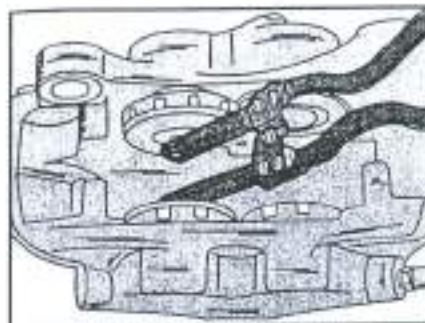
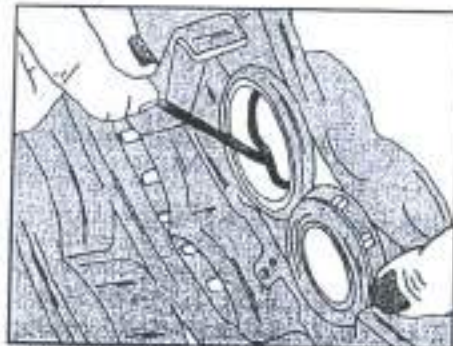

Fig. 7.12 – The rubber dust seals must be pressed in position with a pair of pliers, operating on the principle shown.

7.4. Rear Brakes

Although the construction of the brakes is similar on all models, there are, of course, differences between vehicles with two wheels and four wheels on the rear axle. On models with two wheels, the brake drums are secured with a cross-headed screw and can be removed after unscrewing the screw. If four wheels are fitted, you will have to remove the drive shaft and the brake drum, as has been described in the chapter on the rear axle. If a drum is difficult to remove, release the brake shoes in the manner described for the adjustment of the rear brakes through the holes on the inside of the brake back plates, but note the differences between Perrot and MB adjusters.

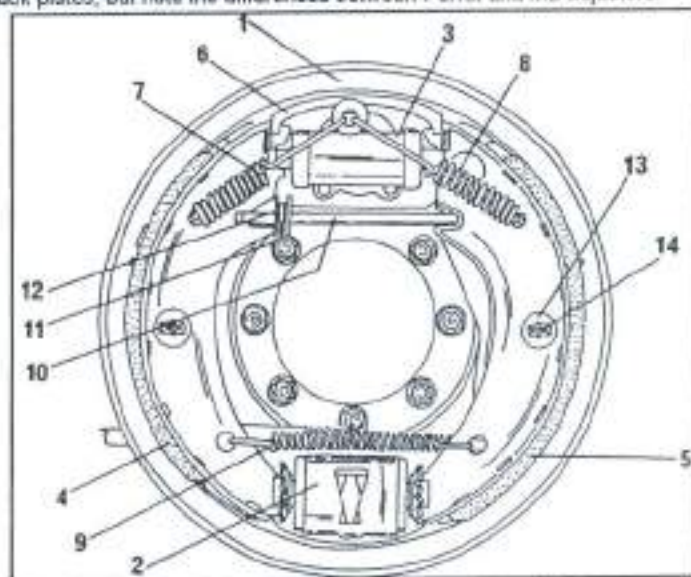

Fig. 7.13 – View of a rear brake assembly, shown with an MB adjuster.

- | | | |
|------------------------|------------------|-----------------------|
| 1 Brake back plate | 6 Support bridge | 11 Spring |
| 2 Brake shoe adjuster | 7 Return spring | 12 Spring seat |
| 3 Wheel brake cylinder | 8 Return spring | 13 Spring seat |
| 4 Trailing brake shoe | 9 Return spring | 14 Shoe hold-down pin |
| 5 Leading brake shoe | 10 Push rod | |

Refer to Section 7.2 for further details. Remove the brake shoes as follows after the drums have been removed. Fig. 7.13 shows a view of the fitted brake shoes on one side and should be referred to.

- Refer to the illustration and remove the two springs (7) and (8) with a pair of pliers or a screwdriver. Take care when removing the springs.
- Remove the brake shoe hold-down pins from both brake shoes. To do this, compress the spring, turn the spring seat by 90°, until the slot in the seat is in line with the head of the pin and release the spring. The pin head will slide through the spring seat and the parts can be removed.

Fig. 7.14 – Push the upper ends of the brake shoes apart until the push rod in the centre can be removed.

- Pull the two brake shoes apart at the upper end Fig. 7.14) and disengage them carefully from the slots in the wheel cylinder pistons. Take care not to damage the rubber boots. The push rod (10) will be released and can be removed. Lift the brake shoes out of the adjuster cylinder and unhook the return spring (9).

- Disconnect the lever on one of the brake shoes from the handbrake cable.
- Note the engagement of the springs which will be found during removal:

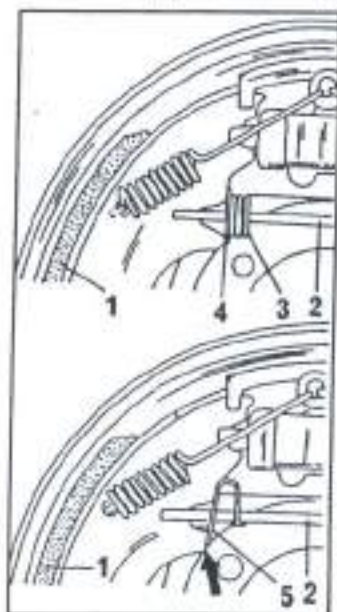
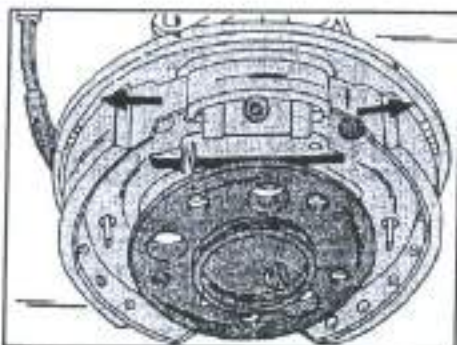

Fig. 7.15 – Arrangement of the springs on the push rod. In the upper view with MB adjuster, in the lower view with Perrot adjuster.

- 1 Front brake shoe
- 2 Push rod
- 3 Spring
- 4 Spring seat
- 5 Leaf spring

- If an MB adjuster is fitted, a compression spring with spring seat is fitted to the push rod, as it is shown in the upper view of Fig. 7.15.
- If a Perrot adjuster is fitted, neither the spring nor the spring seat are fitted. Instead a leaf spring is fitted, as shown in the lower view of Fig. 7.15.

Remove bolt adjuster bolts out of the adjuster housings and clean them thoroughly. Coat the threads with a good long-lasting grease and screw them back into the adjusters. Check that they can be screwed in and out without heavy spots.

Refit the brake shoes as follows and compare the

assembled brake with Fig. 7.13, to make sure that all items have been fitted correctly.

- Engage the lever on the brake shoe with the end of the handbrake cable and loosely place the brake shoe in position.
- Fit the rear shoe with the hold-down pin, the spring and the spring seat to the brake back plate. The spring seat is again turned by 90° until the head of the hold-down spring can be guided through the slot in the spring seat. Then turn the spring seat by a quarter of a turn.
- Engage the upper return spring to the rear brake shoe. Use a hook, as shown in Fig. 7.16 and stretch the spring until it can be engaged.

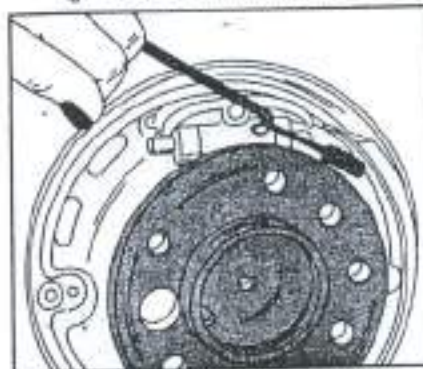

Fig. 7.16 – Return springs can be fitted with a wire hook.

- Fit the push rod between the brake shoes in the manner shown in Fig. 7.17. In the case of an MB adjuster, fit the spring and the spring seat, in the case of a Perrot adjuster fit the leaf spring Fig. 7.14 shows details of the spring attachment.

- Fit the second brake shoe, engage the lower return springs and set the brake shoes in the correct position. Fit the return spring in the manner shown in Fig. 7.16.

Fig. 7.17 – Fitting the push rod between the two brake shoes. Make sure the correct side is facing towards the outside.

- Fit the brake shoe hold-down spring as described for the other brake shoe.
- If an automatic take-up mechanism is fitted, carry out the following operations to set the shoes in the basic position, but note the differences between the two types:

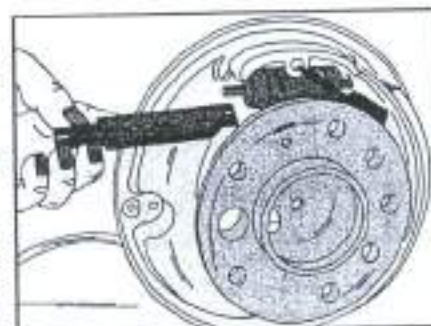
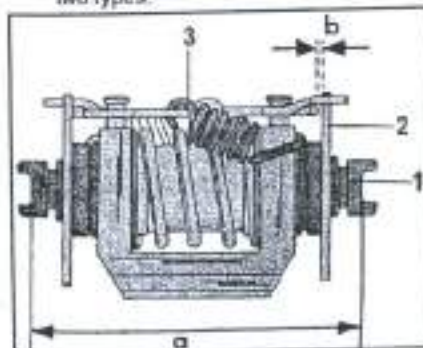

Fig. 7.18 – View of a Perrot brake shoe adjuster. Dimensions "a" and "b" must be adjusted.

- 1 Adjusting screw
- 2 Adjusting wheel
- 3 Tensioning spring

Perrot-Adjuster

- Fit the adjuster in the centre of the elongated hole in the brake back plate. Tighten the bolts finger-tight, not fully. Turn both adjusting screws into the adjuster so that their ends protrude by



the same amount. Then measure the distance between the two bolts and adjust dimension "a" to 70 mm (models 601 and 602) or 86.0 mm (model 611).

Fig. 7.19 – Measuring the gap between the brake shoe lining and the drum surface. The check must be carried out on each brake shoe.



- Fit the brake drum, insert and tighten the screw or refit the brake drum on models with four wheels, as described in Section "Rear Axle".
- To centre the brake drum over the brake shoes, it will be necessary to adjust the gap "b" on each brake shoe. To do this, insert a feeler gauge of 0.4 – 0.5 mm thickness into the opening shown in Fig. 7.19. If the gap is not the same on both sides, move the adjuster in the elongated hole and then tighten the bolts to 4.0 kgm (29 ft.lb.).

Fig. 7.20 – Dimensions "a" and "b" must be set to the values given when brake shoes with Mercedes-Benz adjuster are fitted.

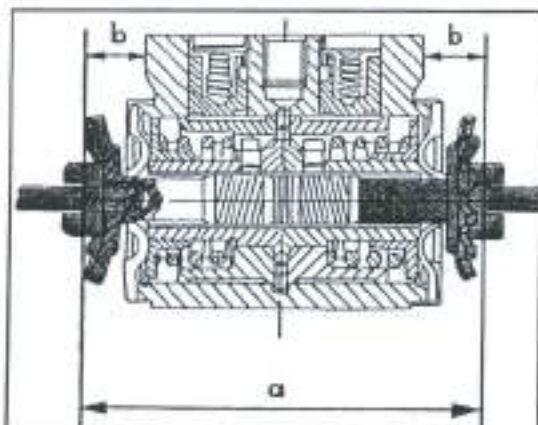

With Mercedes-Benz Adjuster

If the brake shoes or the brake adjuster have been replaced, it will be necessary to carry out certain adjustments on the shoe adjuster, before the brake drum can be refitted. First screw the two adjuster bolts towards the inside or unscrew it, until dimension "a" in Fig. 7.20 is 82.0 mm. Additionally dimension "b" must be set to 11 mm, between the adjuster wheel and the edge of the adjuster housing. The adjustment is the same on all brake drum diameters.

- In case of all models fit the brake drums in accordance with the instructions for the model in question, fit the wheels, lower the vehicle to the ground and tighten the wheel nuts. The handbrake must be adjusted as described later on.
- After the completing all operations, road test the vehicle and operate the brakes in the following manner, taking care not to interfere with other traffic.
- All brake system types are automatically adjusted when the vehicle is driven in the normal direction. In order to adjust the front disc brakes, apply the brakes five times when driving forward and five times when driving backwards.
- If Mercedes adjusters are fitted, the adjusting screw for the leading brake shoe is adjusted when driving forward, the adjusting screw for the trailing brake shoe is adjusted when driving backwards. Brake the vehicle accordingly.

7.4.1 Wheel Brake Cylinders

Wheel brake cylinders can be removed after removal of the brake shoes. Remove the brake pipe at the inside of the brake back plate and unscrew the cylinder from the plate.

Wheel brake cylinders can be overhauled in normal manner, but we suggest to first find out, if a repair kit is available for your type of cylinder.

The cylinder is refitted in reverse order. The bolts are tightened to 6.0 – 7.0 kgm (43.5 – 50.4 ft.lb., fairly high torque). The brakes must be bled of air after installation.

7.4.2 Brake Drums

Brake drums can be re-ground twice, before they must be replaced. The larger diameter of the re-ground drums is compensated by fitting brake shoes with oversize brake shoe linings, which have a normal thickness of 8 mm. Linings with a thickness of 8.5 mm (first repair stage) and 9.0 mm (second repair stage) are available. Brake drums must be re-ground in a workshop, as special mandrels are required to clamp the drums into a lathe.

7.5 Master Brake Cylinder

All models are fitted with a tandem master cylinder with a double reservoir, supplying both circuits of the dual circuit with brake fluid. The brake lines are split as shown in Figs. 7.1 and 7.2.

The brake fluid level is indicated by means of a warning light in the dashboard, when it is below the "Min" mark.

7.5.0. Removal and Installation

The master cylinder is fitted to the front face of the brake servo unit and is removed from the engine compartment.

- Push a bleeder hose over one of the bleed screws in a front brake caliper (remove the rubber dust cap first), suspend the other end of the hose into a container, open the screw and pump the brake pedal until the system has been drained.



Fig. 7.21 – The fitted brake master cylinder.

- Withdraw the cable plug from the brake fluid level contact switch on the side of the reservoir cap.
- Grip the reservoir with both hands and move it to and fro, at the same time pulling it out of the rubber grommets in the cylinder.

- Disconnect the brake pipes from the cylinder and push them carefully to one side. Close the pipe ends in suitable manner to prevent entry of foreign matter.
- Unscrew the cylinder. A rubber sealing ring is inserted between cylinder and brake servo unit. Take care to collect it. Fig. 7.21 shows the cylinder as it is fitted to the brake servo unit.

The installation is a reversal of the removal procedure. Always replace the sealing ring. Tighten the cylinder to 2.0 – 3.0 kgm (14.5 – 29 ft.lb.). There is no need to adjust the brake servo push rod.

Finally fill the reservoir and bleed the brake system as described later on.

7.5.1 Master Cylinder - Overhaul

Master brake cylinders are no longer overhauled. A new cylinder must be fitted if the old one fails. Always quote the model and the chassis number when ordering a new cylinder, as cylinders are sometimes changed and a different cylinder may have been allocated to your particular vehicle.

7.6. Handbrake

7.6.0. Handbrake Adjustment

If no automatic take-up system is fitted to the rear brakes, adjust the brakes as described in Section 7.2, before the handbrake is adjusted.

The adjustment is carried out at the centre of the compensating lever at the underside of the vehicle. This is the mechanism shown in Fig. 7.22. Proceed as follows to adjust the cables:

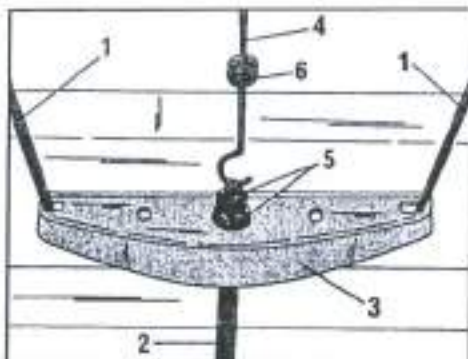

Fig. 7.22 - Handbrake cable attachment underneath the vehicle.

- Apply the handbrake lever a few times, release it fully and then pull it until the third notch engages, irrespective of how many notches the lever can be pulled (3 "clicks").
- Place the rear end of the vehicle on chassis stands (underneath the axle tubes). The wheels must be "in the air".
- Slacken the outer nut of the nuts (2) and tighten the inner nut, until the rear wheels are just binding when rotated.
- Release the handbrake lever and check that both wheels can be rotated freely. Then pull the lever to the 5th notch and check that both wheels are fully locked, when rotated with a fair pressure.
- Tighten the locknut against the adjusting nut, but take care not to turn the adjusting nut whilst doing so (hold the adjusting nut with an open-ended spanner).
- Lower the vehicle to the ground.

7.6.1. Replacing a Handbrake Cable

- Place the rear end of the vehicle on chassis stands (underneath the axle tube).
- Unscrew the two nuts (5) in Fig. 7.22, disengage the return spring and free the two handbrake cables from the compensating lever.
- Remove the spring plates from the intermediate brackets (see Fig. 7.23) and remove the cables from the bearings.

Fig. 7.23 - After removal of the spring plate, withdraw the handbrake cable from the other side of the bracket.

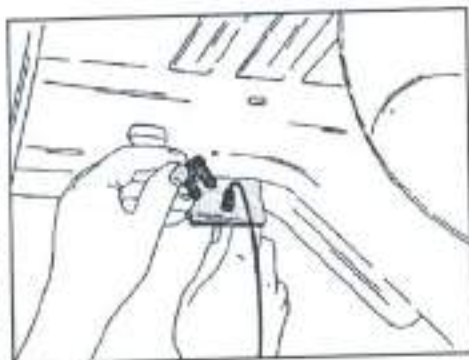

- Remove the spring plates from the handbrake cable on each frame sidemember and withdraw the cables from the other side (see Fig. 7.23).
 - Remove the rear brake shoes as described earlier on. Remove the brake drums on models with twin wheels as described in the chapter on the rear suspension, before the removal of the brake shoes.
 - If one wheel is fitted on each side, unscrew the drum securing screw and withdraw the drum. Remember that you may have to reset the adjuster bolts inside the drums, if the drum is difficult to removed. Do not force the drum, as the brake shoes may be damaged.
 - Disconnect the handbrake cable end from one of the brake shoes.
- The installation is a reversal of the removal procedure. Finally adjust the handbrake as described above.

7.7. Brake Servo Unit

Brake servo units should not be dismantled, as special tools are required to dismantle, assemble and test the unit. Different servo units are fitted to the range covered in this manual. Always make sure to fit the correct unit if the part is replaced. Remember that a failure of the servo unit to act will not affect the efficiency of the brake system but, of course, additional effort will be required for the same braking distance to be maintained.

Note: If you coast downhill without the engine running, for what ever reason, remember that the vacuum in the unit will be used up after a few applications of the brake pedal and the brake system will from then onwards operate without the power-assistance. Be prepared for this.

Fig. 7.24 shows the arrangement of the brake servo unit. Remove the unit by referring to this illustration.

- Remove the master cylinder as already described.
- Disconnect the vacuum hose from the brake servo unit.

- Disconnect the brake servo push rod from the brake pedal. To do this, remove the lock and pull out the pin.
- Remove the brake servo securing nuts from the inside and lift it out from the engine compartment side.

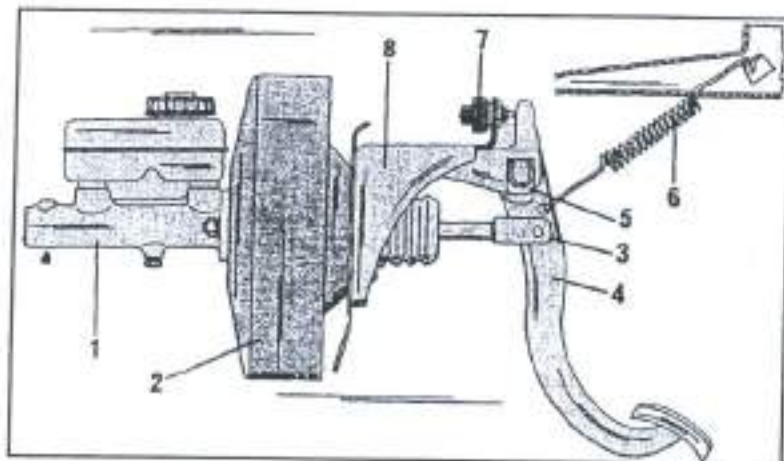

Fig. 7.24 - Brake servo unit and master brake cylinder.

- | | | |
|-------------------------|------------------|---------------------|
| 1 Brake master cylinder | 4 Brake pedal | 7 Stop light switch |
| 2 Brake servo unit | 5 Pedal pin clip | 8 Bracket |
| 3 Push rod | 6 Return spring | |

The installation is a reversal of the removal procedure. Tighten the securing nuts to 2.0 - 3.0 kgm (14.5 - 22 ft.lb.).

7.8. Bleeding of the Brake System

Bleeding of the brake system should be carried out at any time that any part of the system has been disconnected, for whatever reason. If only one of the brake circuits (caliper or wheel brake cylinder) has been opened, either bleed the front or the rear circuit. If both circuits have been opened, first bleed the primary circuit and then the secondary circuit. Figs. 7.1 and 7.2 can be used to follow the circuits. Note that the front calipers have three bleed screws. The upper screw must be bled first. Fig. 7.25 shows the location of the three bleed screws of a front caliper. The procedure given below should be followed and it should be noted that an assistant will be required, unless a so-called "one-man" bleeding kit is available.

Always use clean fresh brake fluid of the recommended specification and never re-use fluid bled from the system. Be ready to top up the reservoir with fluid (a brake bleeding kit will do this automatically) as the operations proceed. If the level is allowed to fall below the minimum the operations will have to be re-started.

- Obtain a length of plastic tube, preferably clear, and a clean container. Put in an inch or two of brake fluid into the container and then go to the first bleed point. Take off the dust cap and attach the tube to the screw, immersing the other end of the tube into the fluid in the container.

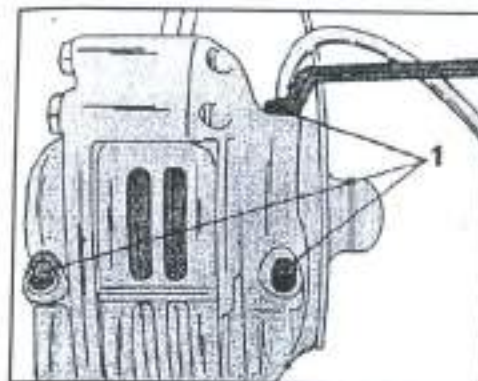

Fig. 7.25 - The location of the three bleeding screws of a front brake caliper.

- Open the bleed screw about three quarters of a turn and have your assistant depress the brake pedal firmly to its full extent while you keep the end of the tube well below the fluid level in the container. Watch the bubbles emerging from the tube and repeat the operation until no more are seen. Depress the brake pedal once more, hold it down and tighten the bleed screw firmly.

• Check the fluid level, go to the next point and repeat the operations in the same way. Install all dust caps, depress the brake pedal several times and finally top up the reservoirs.

7.9 Changing the Brake Fluid

The brake fluid should be changed every two years. In general this is normally not carried out, but we highly recommend it if heavy loads or passengers are carried. Empty the brake system by opening all bleeding screws and pumping the pedal. Old fluid should be collected into a jar as described above.

After filling the fluid reservoir, bleed the system in the manner described above. In this case it is more important to observe the fluid level in the reservoir, as it will sink rapidly. It is of advantage to have an additional helper, one to operate the brake pedal and another one to top-up the reservoir.

Make sure to fit the rubber dust caps over the bleeder screws after the system has been bled. Operate the brake pedal a few times to check the pedal pressure. If the pedal "lifts" during the pumping operation, re-bleed the system.

7.10 Brake Pressure Regulator

The brake pressure regulator can be adjusted. The job, however, must be carried out in a workshop, as pressure gauges are necessary to check and/or adjust the pressure settings.

7.11 Checking the Brake Pad and Brake Shoe Lining Thickness

The remaining thickness of the brake pad and the brake shoe linings can be measured with the brake calipers and brake drums fitted. In the case of the front disc brakes, remove both wheels and check the pad thickness through the "window" in the caliper, as shown in Fig. 7.26. The linings must have a minimum thickness of 2 mm. In the case of the rear brakes, remove the plugs at the inside of the brake back plate (approx. in the centre on the L.H. and R.H. side) and shine a torch into the openings. The edges

of the brake shoes can be seen. If the thickness of the lining has approached the thickness of the brake shoe, replace the brake shoes as a set.

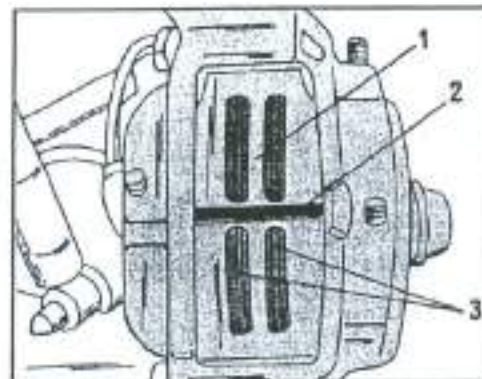

Fig. 7.26 – After removal of the front wheel you will be able to check the lining thickness.

- 1 Metal cover
- 2 Retaining pin
- 3 Brake pads

7.12. Vacuum (Exhauster) Pump

A double-acting vacuum pump is bolted to the crankcase and supplies the vacuum for the operation of the brake servo unit and all other auxiliary units requiring vacuum for their operation. The pump is driven by means of a cam from the injection point advancer on the fuel injection pump and lubricated by splash oil from the lubrication of the engine.

The pump has two separate suction circuits (therefore double-acting). The first circuit supplies the brake servo unit, the second one supplies secondary units, i.e. the idle speed increase inside the fuel injection pump (if fitted) or the pneumatic stop control for the engine.

The pump can be replaced as follows:

- Remove all parts in front of the pump, i.e. fan shroud (cowling), cooling fan, drive belt, etc. to create enough space for the removal of the pump.
- Disconnect the hose from the connector.
- Unscrew the union nuts and withdraw the pipe.
- Remove the bolts and remove the pump from the front of the engine.

The installation of the pump is a reversal of the removal procedure.

7.13. Brakes – Tightening Torques

Brake servo unit	2.1 – 2.9 kgm (15 – 21 ft.lb.)
Master brake cylinder	2.1 – 2.9 kgm (15 – 21 ft.lb.)
Brake pipe union nuts	1.2 – 1.6 kgm (9 – 11.5 ft.lb.)
Bleeder screws	1.2 – 1.6 kgm (9 – 11.5 ft.lb.)
Wheel brake cylinders	6.0 – 7.0 kgm (43.5 – 50.5 ft.lb.)
Adjuster to brake back plate	7.0 – 7.5 kgm (50.5 – 54 ft.lb.)
Brake caliper to steering knuckle	19.0 – 20.0 kgm (137 – 144 ft.lb.)
Rear brake back plate to axle	4.5 – 5.0 kgm (32.5 – 36 ft.lb.)

8 Electrical System

8.0 Battery

Voltage	12 volts
Polarity	Negative earth
Capacity	72 Ah

Condition of Charge:

- Fully charged	1.280
- Half charged	1.200
- Discharged	1.120

To check the voltage of the battery, use an ordinary voltmeter and apply between the two battery terminals. A voltage of 12.5 volts or more should be obtained.

If a hydrometer is available, the specific gravity of the electrolyte can be checked. The readings of all cells must be approximately the same. A cell with a low reading indicates a short circuit in that particular cell. Two adjacent cells with a low reading indicates a leak between these two cells.

A battery can be re-charged, but the charging rate must not exceed 10% of the battery capacity, i.e. 7.2 amps. The battery must be disconnected from the electrical system. Charge the battery until the specific gravity and the charging voltage are no longer increasing within 2 hours. Add distilled water only. Never add acid to the battery.

The level of the battery electrolyte should always be kept above the top of the plates.

8.1. Alternator

8.1.0. ROUTINE PRECAUTIONS

The vehicles covered in this manual employ an alternator and control unit. This equipment contains polarity-sensitive components and the precautions below **must** be observed to avoid damage:

- Check the battery polarity **before** connecting the terminals. Immediate damage will result to the silicon diodes from a wrong connection - even if only momentarily.
- Never disconnect the battery or alternator terminals **whilst** the engine is **running**.
- Never allow the alternator to be rotated by the engine unless **ALL** connections are made.
- Disconnect the alternator multi-pin connector **before** using electric welding equipment anywhere on the vehicle.
- Disconnect the battery leads if a rapid battery charger is to be used.
- If an auxiliary battery is used to start the engine, take care that the polarity is correct. **Do not** disconnect the cables from the vehicle battery.

8.1.1. REMOVAL AND INSTALLATION

The alternator is rigidly attached to the engine. Remove as follows:

- Disconnect the battery.
- Disconnect the cable harness by withdrawing the plug at the rear end of the alternator. Also disconnect the single cable.
- Slacken the alternator drive belt as described in the section dealing with the cooling system and lift off the belt.
- Remove the two alternator mounting bolts from the locations shown in Fig. 8.1 and lift out the alternator. It may be necessary to carry out the operations from below the vehicle, if it is difficult to lift the alternator out of the engine compartment from above.

Fig. 8.1 – The alternator mounting bolts. The drive belt has already been removed.

Note: If a 2.9 litre engine is fitted, you may find that the upper mounting screw will interfere with the plastic cooling fan blades when the alternator is removed. If this is the case, first remove the lower bolt and then lift the alternator as shown in Fig. 8.2. Then remove the complete alternator mounting bracket, before the complete unit is removed.

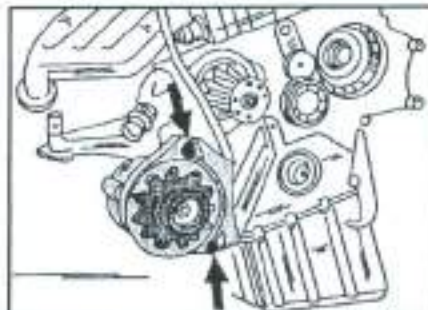
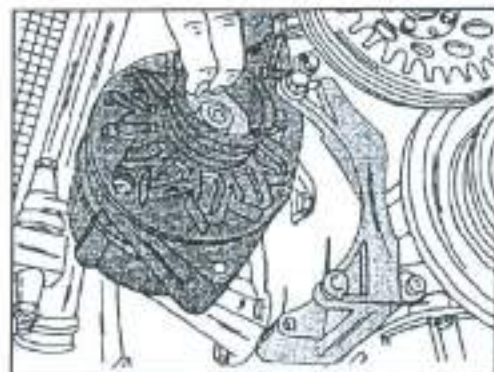

Fig. 8.2 – Removal of the alternator when a 2.9 litre engine is fitted. The alternator is held as shown to remove the mounting bracket (R.H. side).



The installation of the alternator is a reversal of the removal procedure. Take care to make the correct connections. Adjust the drive belt tension.

8.1.3. SERVICING

A Bosch alternator is used on the engines dealt with in this manual, having an output of 55 amps. We do not recommend that the alternator or control unit should be adjusted or serviced by the owner. Special equipment is required in the way of test instruments and the incorrect application of meters could result in damage to the circuits.

The alternator is fitted with sealed-for-life bearings and no routine attention is required for lubrication. Keep the outside of the alternator clean and do not allow it to be sprayed with water or any solvent.



Fig. 8.3 – The ends of the alternator brushes must protrude by at least 5 mm.

The alternator brush gear runs in plain slip rings and the brushes have a long life, requiring inspection only after a high mileage has been covered. To inspect the brushes, we recommend the removal of the alternator. Take out the two screws from the brush holder assembly and withdraw for inspection. Measure the length of the brushes, shown by "a" in Fig. 8.3. If the protruding length is less than 5.0 mm (0.2 in.) or approaching this length, replace the brushes. New brushes will have to be soldered in position. We would like to point out that it is not an easy operation to guide the brushes over the slip rings when the slip ring cover is being fitted.

8.2. Starter Motor

A Bosch pre-engaged starter motor with an output of 2.2 kW is fitted to the models covered in this manual.

8.2.0. REMOVAL AND INSTALLATION

- Disconnect the battery earth (ground) cable.
- Remove the starter motor mounting bolts.
- Disconnect the starter motor cables from the starter motor solenoid switch. Withdraw the unit from the vehicle. The unit must be guided past the engine crossmember. Tilt the motor so that the solenoid switch is facing downwards and then remove it sideways.

Install in the reverse sequence to removal. Tighten the starter motor bolts to 4.5 kgm (32.5 ft.lb.). Make sure that the mating faces are clean before bolting up. Re-connect the wires and the battery terminals. Tighten the nut to 2.5 kgm (18 ft.lb.).

8.2.1. SERVICING

It may be of advantage to fit an exchange starter motor if the old one has shown faults. Exchange starter motors carry the same warranty as new units and are therefore a far better proposition.

The following repairs can, however, be attempted without any problems:

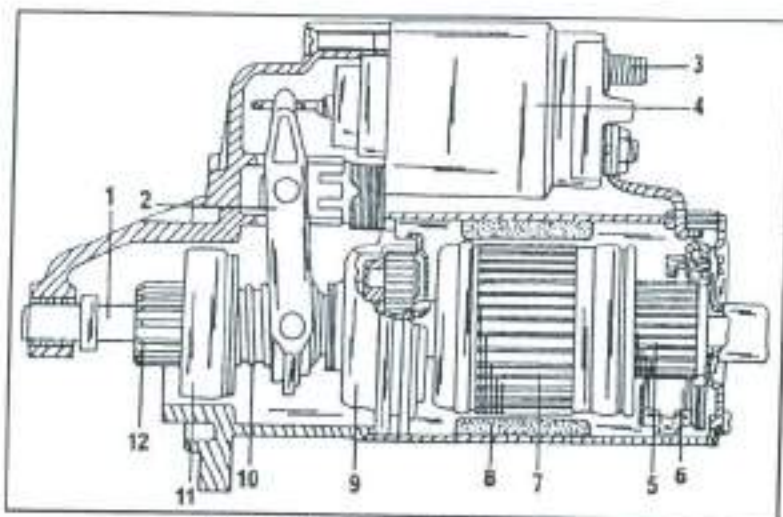

Fig. 8.4 - Sectional view of the starter motor.

1 Armature shaft	5 Commutator	9 Planetary gear
2 Engagement lever	6 Carbon brush	10 Engagement spring
3 Terminal, battery cable	7 Armature	11 Free wheel clutch
4 Solenoid switch	8 Permanent magnet	12 Starter motor pinion

Solenoid Switch

- Disconnect the cable between the solenoid switch and the starter motor terminal.
- From the front of the solenoid switch remove the bolts and withdraw the switch from the starter motor, at the same time disengaging the engagement lever from the starter motor drive.
- Refit the new switch in reverse order.

Starter Motor Brush Replacement

- Unscrew and remove the cover from the rear of the starter motor.
- Remove the two screws securing the commutator bearing cover.
- Remove the "C" clip from the rear end of the armature shaft (screwdriver), remove the sundry parts and withdraw the cover from the starter motor yoke. If necessary insert a screwdriver to get the parts apart. Remove the shims.
- Remove the brushes from their holders. The brush leads are either screwed-on or soldered. If they are soldered, you will have to be familiar with a soldering iron. Otherwise take the unit to an auto electrical repair shop to have the bushes replaced.
- Replace the brushes as applicable and re-assemble the starter motor in reverse order.

8.2.2. Starter Motor Faults

Following are a few tips to locate faults in the starting system before the starter motor is replaced:

- When the key is turned to the starting position, the starter motor turns very slowly, nothing happens and starts to crank the engine and stops: If the warning lights in the instrument panel are nearly or fully extinguished, check the battery. Loose or corroded cables on the starter motor, bad earth connection are other causes. If the battery has been connected previously, check the terminals for good contact. Use a jumper lead or get a tow-start to start the engine.
- If the warning lights in the instrument panel remain "on" and a faint click is heard from the area of the starter motor, it is possible that the engagement plunger of the solenoid switch is sticking. Use a heavy spanner and knock against the outside of the switch. Sometimes this will free the plunger. Other causes are worn starter motor brushes or defective contacts in the solenoid switch. In both cases remove the starter motor to replace the bushes and/or the solenoid switch. If the warning lights remain "on" and no click can be heard, check the cable connections between battery and starter motor.
- If the starter motor is heard to operate without cranking the engine, suspect a damaged solenoid switch, or the engagement mechanism, the starter motor pinion of the flywheel teeth are damaged. Try to engage a gear, push the vehicle backwards and forwards a few times and try the starter motor again. Otherwise fit a new starter motor.
- If the starter motor "spins" after the engine has started and the key has been turned to the normal position, a sticking solenoid switch is mostly the cause for the fault (contacts fail to open). The ignition switch can also be damaged. Immediately switch off the engine.
- If the starter motor pinion "spins" after starting the engine (howling noise), switch off the engine immediately. In most cases a new starter motor will be necessary.

8.3. Headlamps

8.3.0. Headlamp/Side Light Bulb - Replacement

All front bulbs are fitted to the rear of a light unit. An "H4" headlight bulb is replaced as follows:

- Open the bonnet and from the rear of the headlight unit remove the plastic cover by turning it into the direction "2" of the arrow in Fig. 8.5.



Fig. 8.5 - View of a headlamp unit from the rear. Remove the plastic cover in direction (1) and refit it in direction (2).

- 1 Vertical adjusting screw
- 2 Horizontal adjusting screw

- Withdraw the multi-plug connector from the headlamp bulb, push the bulb holder towards the inside, at the same time turning it anti-clockwise. Remove the bulb when the bulb holder is free.

- Fit the new bulb into the holder. Do not touch the bulb with your fingers.

The bulb has a locating tab which must engage properly. Push the bulb holder in position and turn it clockwise.

Fig. 8.6 – Headlamp bulb (1) and sidelight bulb (2) fitted to the bulb holder.

- To replace the side light bulb, push it down and at the same time turn it anti-clockwise. Fig. 8.6 shows where the two bulbs are located.

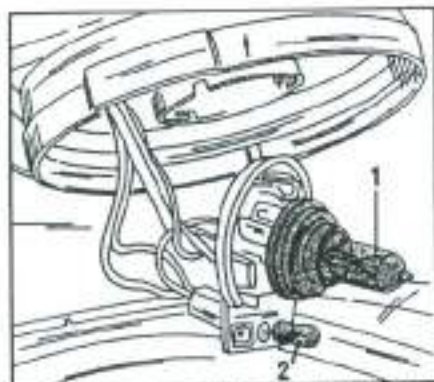

8.3.1. Replacing a Headlamp Unit

The headlamp units are attached from the outside by means of four screws to the front section of the vehicle, as shown in Fig. 8.7. The radiator grille must be removed to remove a headlamp unit. Remember that the headlamps must be adjusted. We recommend to have the adjustment carried out at a dealer.

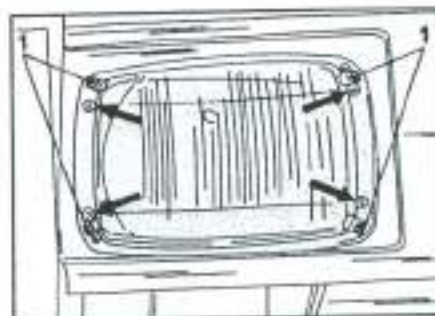

Fig. 8.7 – The arrows point to the securing screws of a headlamp. The four small brackets (1) secure the headlamp lens to the headlamp housing (not the same on all model versions).

To replace the headlamp lens, remove the four screws (1) securing the frame. Adjust the headlamps provisionally after installation.

8.3.2. Headlamp Adjustment

The adjustment of the headlamps depends on the model version. Headlamps are either adjusted from the outside by means of screws (screwdriver adjustment) or from the inside by means of screws with knurled nuts. The adjustment arrangement from the outside requires a screwdriver to be inserted through openings in the radiator grille. One screw is located left at the lower end, the other one right at the upper end.

If the headlamps are adjusted from the inside you will find the two knurled nuts on opposite sides of the headlamp, as can be seen in Fig. 8.5. Use adjusting screw (3) to move the headlamp beam up or down, use adjusting screw (4) to adjust the beams from left to right. Refer to Fig. 8.8 for the location of the adjusting screws when the headlamps are adjusted from the outside.

The headlamps should be adjusted with optical equipment and only in emergency should you reset the headlamps.

- Start the engine and, if fitted, turn the light beam height regulation to position "0".

Fig. 8.8 – The headlamp adjusting screws when the beams are adjusted from the outside. On the left for the vertical adjustment, on the horizontal adjustment.

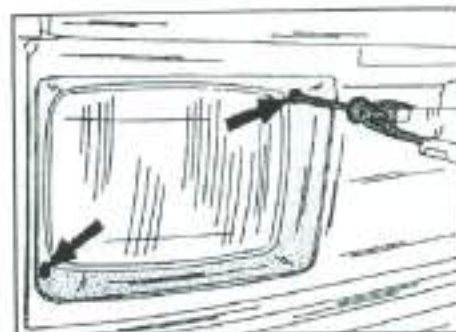

- Drive the vehicle in front of a dark wall or garage door and switch on the headlamps. If only one headlamp requires adjustment, set the beam to the same height as the other headlamp.
- If both headlamps must be adjusted, transfer the centre point of each headlamp to the wall or door by measuring from the ground to the headlamp, the dimension between the headlamps, etc. The vehicle must be 10 m away from the adjusting area. Prepare the area in accordance with Fig. 8.9. Mark the headlamp centre point "d" through a line "F", after you have measured the distance from the ground to the headlamp centre.

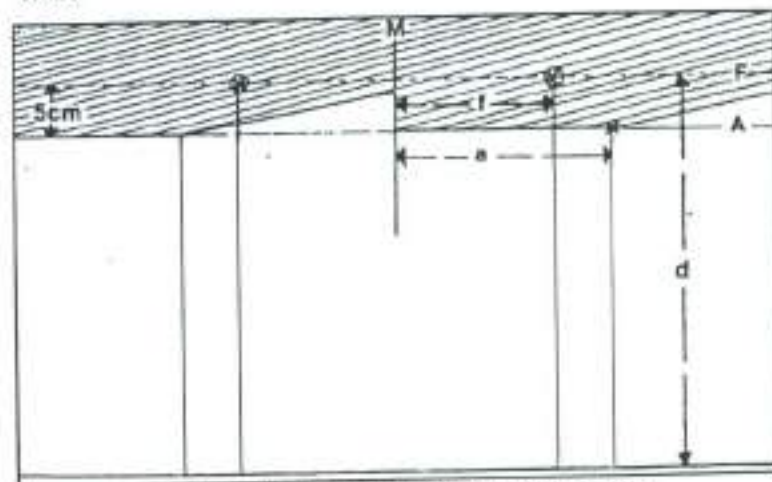

Fig. 8.9 – Adjusting diagram for the headlamps (refer to text).

- Mark a second line "A" 5 cm below line "F". This is the reference line for the dipped beam.
- From the vehicle centre line "M" mark the centre point of each headlamp with "a" for the high beam and "f" for the dipped beam.
- Switch the headlamps to high beam, place a blanket over one headlamp and check that the light beam is identical with the centre of the cross "f" for the headlamp in question. If this is not the case, adjust the headlamp with the adjusting screws shown.
- Check the high beam adjustment of the other headlamp in the same manner.
- Switch the headlamps to dipped beam and check that the light beam is identical with the line "a" of each headlamp.

Note: Have the headlamp adjusted checked professionally at the earliest opportunity. Only consider the above instructions in an emergency.

8.4. Windscreen Wipers

The heater box must be removed to gain access to the windscreen wiper linkage and the wiper arm spindle bearing on the R.H. side. To remove a wiper linkage, use a screwdriver as shown in Fig.8.10 to remove it from the spindle bearing or the windscreen wiper motor lever. Push the linkage in position during installation.

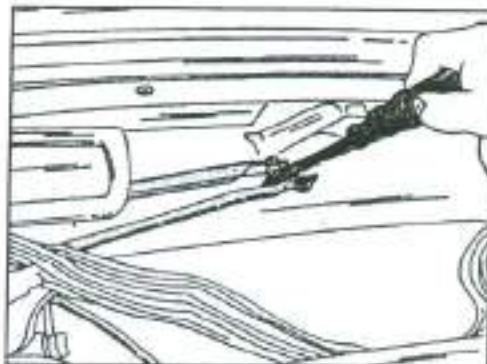

Fig. 8.10 - Wiper linkages are separated with a screwdriver as shown.

To remove the wiper spindle on the R.H. side, remove the wiper arm from the outside, remove the nut securing the spindle bearing and remove the spindle from the inside.

The L.H. wiper spindle bearing can be removed with the heater box in position.

The instrument insert must be removed to gain access for the removal of the wiper motor (2

screws at the top and 2 at the bottom). Switch on the wipers and switch off the ignition key as soon as the wiper arms are on the L.H. side. Wiper motor and linkages can only be replaced in this position.

Fig. 8.11 - The arrows show where the securing screws for the wiper motor are located.

Remove the linkage connected to the R.H. spindle bearing as shown in Fig. 8.10 and unscrew the motor from the bracket. The securing bolts are shown in Fig. 8.11. Remove the cable connector plug and remove the motor with the linkage attached. Remove the linkage from the motor. The installation is carried out as follows:

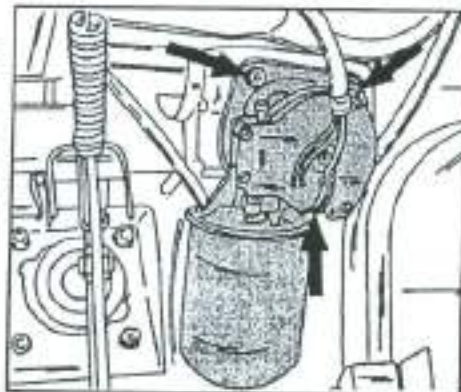

- Push the short wiper linkage onto the wiper motor crank arm.
- Refill the wiper motor with the linkage and bolt in position. The lever on the motor shaft and the linkage must face towards the R.H. spindle bearing.
- Connect the linkage to the R.H. spindle bearing. If this appears difficult, disconnect the cable harness from the heater box, connect the linkage and re-connect the cable harness.
- The remaining operations are carried out in reverse order.

The above engine is fitted to models 207D and 307D. The following sections cover the main differences of the engine, compared with the later 601 and 602 engines.

9.0. Removal and Installation of the Engine

The engine is removed together with the transmission. Follow the operations given for the other engines.

9.1 Cylinder Head

9.1.1. Removal and Installation

The cylinder head must only be removed when the engine is cold. The head is removed together with the inlet and the exhaust manifold. New cylinder head gaskets are wrapped in plastic and must only be unwrapped just before the gasket is fitted. The cylinder head can be removed with the engine fitted and these operations are described below:

- Place the engine bonnet into vertical position as described during the removal of the engine.
- Drain the cooling system (Section 1.8.1).

Fig. 9.1 - The two bolts shown by the arrows secure the fuel filter to the engine.

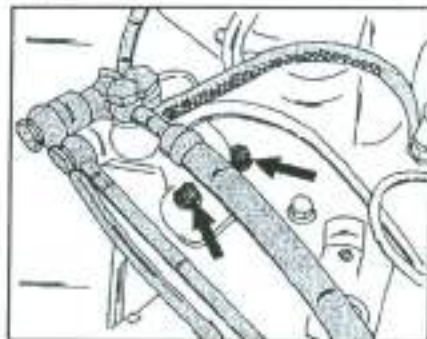

- Remove the engine cover in the drivers cabine, followed by the cylinder head cover. A sticking cylinder head cover must not be freed by tapping it with a hammer. If difficult to remove, try to unstick it by pushing it by hand to one side. Use a plastic mallet carefully, if necessary.
- Disconnect the battery earth cable.
- Remove the two bolts shown by the arrows in Fig. 9.1 and take off the fuel filter without disconnecting the fuel hoses. Only disconnect the hose leading to the injector No. 1.
- Disconnect all coolant, fuel and vacuum hoses and the electrical cables connected to the cylinder head or any other unit on the head which cannot be removed together with the head.
- If an automatic transmission is fitted, remove the oil dipstick guide tube for the transmission from the inlet manifold.
- Disconnect the throttle control cable. To do this, remove a securing clip and withdraw the long linkage towards the rear. Unscrew the bracket and the idle speed regulating cable together with the plastic bush.

- Disconnect the exhaust pipe from the exhaust manifold flange and free the exhaust pipe from the bracket on the transmission.
- Disconnect the injection pipes. Immediately cover the open connections in suitable manner to prevent entry of dirt.
- Remove the three hoses from the thermostat housing and the vent line between the coolant pump housing and the cylinder head.
- Rotate the engine until the piston of No. 1 cylinder is at top dead centre in the firing position, i.e. the "O" mark must be opposite the adjusting pin. A 27 mm socket can be applied to the crankshaft pulley bolt to rotate the crankshaft. Never attempt to rotate the crankshaft by applying a socket to the camshaft timing wheel bolt. The crankshaft must be rotated in the direction of rotation (refer to Fig. 1.12).
- Remove the chain tensioner as described later on.
- Mark the camshaft sprocket and the timing chain at opposite points, as shown in Fig. 9.2, using a spot of paint.

Fig. 9.2 - Mark the camshaft timing gear and the timing chain with a spot of paint before separation of the parts.



- Unscrew the camshaft sprocket bolt. To counterhold the camshaft against rotation, insert a strong screwdriver blade or steel bolt into one of the holes of the camshaft sprocket.
- Remove both rocker shafts. Turn the camshaft so that the rocker levers are not under tension. Withdraw the camshaft sprocket and carefully lower the timing chain into the timing chamber.
- Remove the slide rail from the cylinder head as described later on.
- In the timing chain case remove two M8 bolts ("a" in Fig. 9.3). A 6 mm Allen key is required to remove the bolts. A suitable extension must be used to reach the bolts.

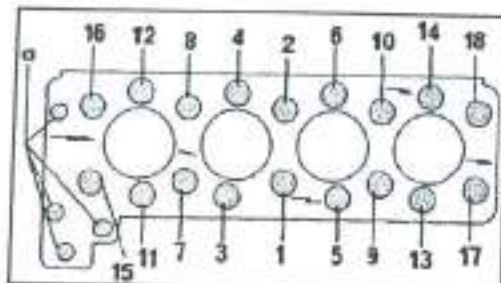

Fig. 9.3 - Tightening sequence for the cylinder head bolts. Slacken the bolts in reverse order. The bolts marked with "a" are the 8 mm bolts referred to in the text.

- Unscrew the cylinder head bolts in reverse order to the one shown in Fig. 9.3. A multi-spline bit must be used to slacken the bolts. A normal Allen key is not

suitable, as it will damage the bolt heads. Remove the injectors to gain access to the bolts "4" and "5". Immediately after removal of the bolts measure their length. If the dimension from the end of the bolt to the underside of the bolt head is more than 105.5, 120.5 or 145.0 mm, depending where the bolts are located, replace the bolts. New bolts have a length of 104.0, 119.0 or 144.0 mm.

NOTE: Cylinder heads of earlier engines are secured with normal socket head bolts, and a straight Allen key is required to unscrew or tighten them.

- Lift off the cylinder head. If a hoist or other lifting equipment is available, hook a rope to the two lifting eyes and lift off the head. Remove the cylinder head gasket.
- Immediately after removal, clean the cylinder head and block surfaces of old gasket material.
- If necessary, overhaul the cylinder head as described in Section 9.1.1 after dismantling.

Install the cylinder head in the following manner:

- Place a new cylinder head gasket in position. Make sure you obtain a gasket for the engine in question (quote engine number and model year).
- Place the cylinder head carefully in position, taking care to engage the dowel sleeves. Use a soft-faced mallet to tap the head in position.
- Coat the threads of the cylinder head bolts with oil. It is assumed that original bolts have been measured for their re-use.
- Insert the cylinder head bolts and tighten them in the sequence shown in Fig. 9.3 in several stages. If standard socket head bolts are fitted, tighten the head to a torque of 10.0 kgm (72 ft.lb.) using a straight Allen key with socket. The tightening is carried out in stages as follows:
 - Tighten all bolts in the correct order to 7.0 kgm (50.5 ft.lb.).
 - Tighten all bolts in the correct order to 9.0 kgm (65 ft.lb.).
 - Wait 10 minutes.
 - Tighten all bolts in the correct order to 10.0 kgm (72 ft.lb.).

NOTE: The bolts are of different length and must be fitted accordingly.

- If cylinder head bolts with multi-tooth socket heads are used, use the correct multi-spline bit and tighten the cylinder head as follows:
 - Tighten all bolts in the correct order to 4.0 kgm (30 ft.lb.).
 - Tighten all bolts in the correct order to 7.0 kgm (50.5 ft.lb.).
 - Wait 10 minutes.
 - Angle-tighten all bolts in their correct tightening order. To do this, insert the multi-spline bit with the socket into each bolt and fit the tommy bar so that it is in line with the longitudinal axis of the engine. Tighten the bolt until the tommy bar is at right angle to the engine, i.e. the bolt has been tightening by 90° (1/4 of a turn). Tighten all other bolts in the same manner.
 - Angle-tighten all bolts in the correct order by a further 90°.
- Fit the two socket head bolts to the inside of the timing chain chamber and tighten them to 2.5 kgm (18 ft.lb.).

NOTE: Multi-spline head socket bolts require no re-tightening after they have been fitted as described above. Socket head bolts must be tightened after 300 to 600 miles, as described above. To do this, slacken each bolt in the order shown in Fig. 9.3 and immediately re-tighten it to 10.0 kgm (72 ft.lb.).

- Refit the slide rail to the head as described later on.
- Fit the camshaft sprocket together with the timing chain to the end of the camshaft, making sure that the paint marks made during removal are in line. The sprocket must engage with its bore over the dowel pin in the camshaft.
- Fit the camshaft sprocket bolt and tighten the bolt to 8.0 kgm (58 ft.lb.). Counterhold the camshaft by inserting a strong screwdriver blade or steel bolts through one of the openings in the sprocket.
- Refit the timing chain tensioner.
- Refit the rocker shaft assembly.
- Check the marking for top dead centre for the No. 1 cylinder in the camshaft. A notch is machined into the camshaft which should be in line with a mark machined into the cylinder head. The alignment can be seen by looking from above.
- Re-connect the glow plug cables.
- Adjust the valve clearances.
- Refit the injectors and connect the injection pipes.
- The remaining operations are carried out in reverse order to the removal procedure.

9.1.2. Cylinder Head - Dismantling

The following description assumes that the cylinder head is to be replaced. If only a top overhaul is asked for, ignore the additional instructions. The cylinder head must be removed.

It should be noted that special tools are required to remove the valves. A spanner is required to counterhold the valve spring cups (No. 615 589 00 01 00) and two valve adjusting spanners with 14 mm across the flats (No. 615 589 00 01 00) are used to slacken the dome nuts and locknuts of the valves. Proceed as follows during dismantling:

- Remove all auxiliary parts from the cylinder head, including the inlet and exhaust manifolds.
- Valves are not held in position by the usual valve cotter halves, but by means of a dome nut with locknut. Dome nuts have been changed during production and only the later version is supplied. Valve spring cups have also been modified (February 1981). The new cups are suitable for all engines.

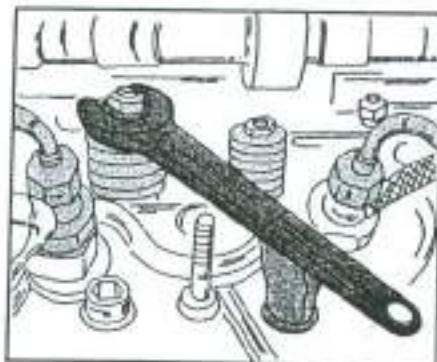

Fig. 9.4 - Counterhold the valve spring cup as shown when removing the valves.

Apply the spanner as shown in Fig. 9.4 to counterhold the valve spring cup. Remove the dome nut from each of the valves, using the valve adjusting spanner. The locknut below each dome nut must be held with a second spanner and can be removed after the dome nut has been unscrewed. Fig. 9.5 (next page) shows a sectional view of a valve with the position of the individual parts.

- Remove the spring cup, valve spring, valve stem oil seal and the "rotocap" (prevents valves from rotating). Valve springs (one per valve) are with paint spots. Only use springs with the same colour identification of springs are replaced. Remove valve stem oil seals carefully with a screwdriver or a pair of pliers.
- Remove the valves one after the other out of the valve guides and pierce them in their fitted order through a piece of cardboard. Write the cylinder number against each valve if they are to be re-used.

Fig. 9.5 - Valve stem and valve spring in a sectional view.

- 1 Dome nut
- 2 Locknut
- 3 Valve spring seal
- 4 Valve spring
- 5 Valve stem seal
- 6 Valve
- 7 Valve guide
- 8 "Rotocap"

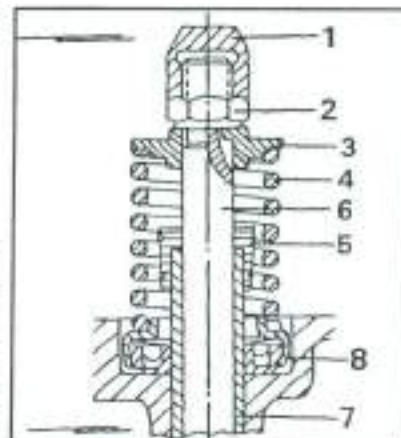

- A few words should be said about the camshaft. The camshaft has three bearings, all having the same diameter. The camshaft is located in axial direction by the No. 1 bearing cap. Excessive end float is due to a worn bearing cap thrust face.

- Camshafts are marked with identification numbers. If a shaft is replaced, only fit a shaft with the same number.

9.1.3 Cylinder Head - Overhaul

The cylinder head must be thoroughly cleaned and remains of old gasket material removed. The checks and inspections are to be carried out as required.

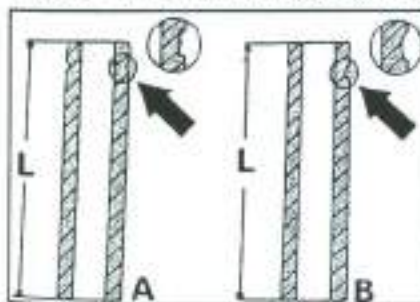

Fig. 9.6 - View of the earlier valve guides (A) and the later guides (B).

Valve Springs: Refer to Page 24. See Page 15 for spring data.

Valve Guides: Valve guides for inlet and exhaust valves are made of cast iron and have the same diameter. Guides for exhaust valves are shorter. Valve guides have been modified in

their length during production and only the shorter guides are available as replacement parts. These guides are marked as shown in Fig. 9.6 and only the guides shown in the R.H. view must be fitted to engines covered in this manual.

Valve guides can be checked and replaced as described on Page 25.

Guides are removed with a shouldered mandrel from the combustion chamber side of the cylinder head, as shown in Fig. 9.7. If guides with nominal dimension can be

Fig. 9.7 - Pressing out a valve guide.

used, drive them in position, until the dimension between the cylinder head face and the lower end of the valve guide is 32.0 mm (1.26 in.) in the case of the inlet valve guides and 43.5 mm (1.71 in.) in the case of the exhaust valve guides. A tolerance of 0.5 mm is permissible. If repair size valve guides are fitted, the locating bores in the cylinder head must be reamed out

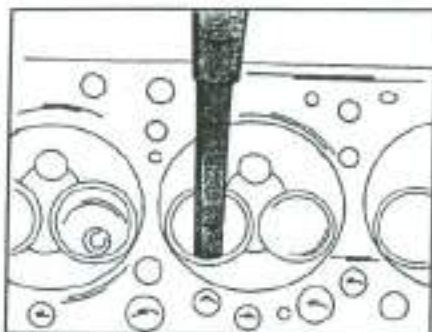

Fig. 9.8 - Measuring the distance between the cylinder head surface and the end of the fitted valve guide.

to take the new guides. Heat the cylinder head in boiling water and press in the guides until the dimensions given above are obtained. Measure the installation height of the valve guides as shown in Fig. 9.8.

Before a valve guide is replaced, check the general condition of the cylinder head. The guides must be reamed after installation, and after the cylinder head

has cooled down, if applicable, to their correct internal diameter, given on Page 18. Note that all guides have the same internal diameter.

Valves must always be replaced if new valve guides are fitted. The valve seats must be re-cut when a guide has been replaced. If it is obvious that seats cannot be re-ground in the present condition, new valve seats inserts must be fitted and the work should be carried out in a workshop.

Fig. 9.9 - The important valve seat dimensions (Refer to Section 1.3.0.)

- a Valve seat angle
- b Valve seat width

Valve Seats: If the camshaft bearings are excessively worn, fit a new or exchange cylinder head. In this case there is no need to renovate the valve seats.

Check all valve seats for signs of pitting or wear. Slight indentations can be removed with a cutter. If this operation is carried out properly, there should be no need to grind-in the valves. Use correction cutters to bring the valve seating area into the centre of the valve seat. Make sure that the valve seat width, given in Section 1.3.0, is obtained. This again is achieved by using cutters of different angles (15 and 60°). Valve seat inserts can be fitted to the cylinder head (workshop).

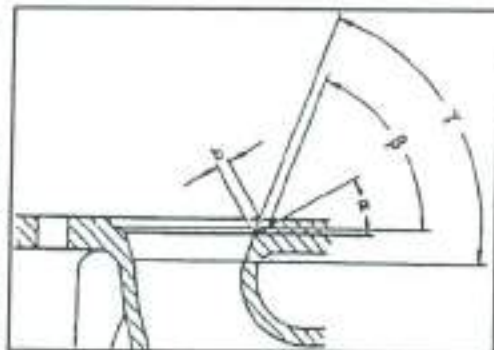

Replacement of valve seat inserts will require that the old seat insert is removed by machining. The machining must not damage the bottom face of the head recess. As this is a critical operation, we advise you to bring the cylinder head to your Mercedes Dealer who has the necessary equipment and experience to do the job. Fig. 9.9 shows a valve seat. It may be possible to obtain a reconditioned cylinder head in exchange for the old one to avoid time delay. In this case remove all ancillary parts from the old head and refit them to the new head.

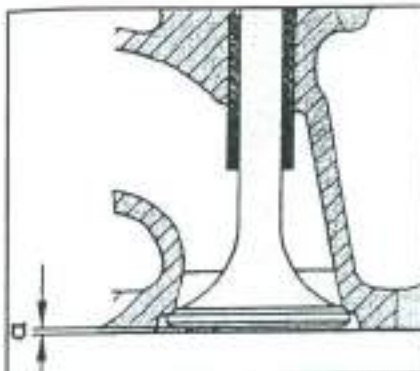

Fig. 9.10 - The dimension "a" must not exceed 1.5 mm for re-used and new valves.

If the valve seats have been re-cut, use the valve and measure the dimension "a" in Fig. 9.10. To do this, insert the valve into the respective bore and, using a depth gauge, measure the gap between the cylinder head face and the valve face, as shown in Fig. 9.11.

Valves can be ground into their seats in the conventional manner.

Fig. 9.11 - Measuring the distance between the valve head face and the cylinder head surface.

Valves:

Valves can be cleaned best with a rotating wire brush. Check the valve faces for wear or grooving. If the wear is only slight, valves can be reground to their original angle in a valve grinding machine, but make sure that there is enough material left to have an edge on the valve head (min. 1.5 mm/0.06 in.), as shown by "r" in Fig. 9.12.

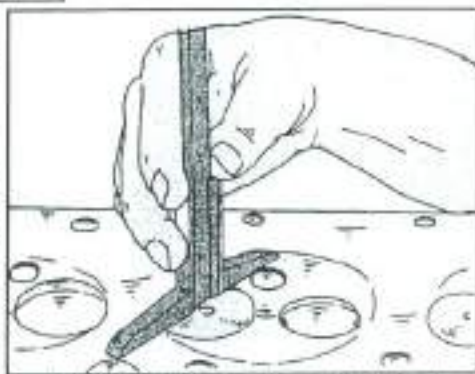

Fig. 9.12 - The valve head edge must be measured before a valve is refitted. The minimum permissible dimension is 1.5 mm.

Measure the valves in accordance with the values given in Section 1.3.0, and replace any valve which is outside the limits given. Note the following when valves are replaced. Note that these valves are not filled with sodium, as is

the case with other Mercedes engines.

Always quote the model year and the engine number when ordering new valves, as different valves are used. These are marked by means of a number in the end of the valve stem. The valves are marked as follows:

Inlet Valves:	E 616 02
Exhaust Valves:	A 616 05

Sometimes it is only required to replace the exhaust valves, if these for example are burnt out at their valve head edges.

Cylinder Head: Refer to Page 27. If a feeler gauge of more than 0.10 mm (0.004 in.) can be inserted, when the ruler is placed along the cylinder head, have the cylinder head face re-ground. If the measurement is carried out across the cylinder head, there should be no gap. The min. height of the cylinder head must not be less than 84.0 mm (3.31 in.). If the cylinder head is reground, correct the fitting dimension of the valves ("a", Fig. 9.10) accordingly. This will, however, be a job for the workshop.

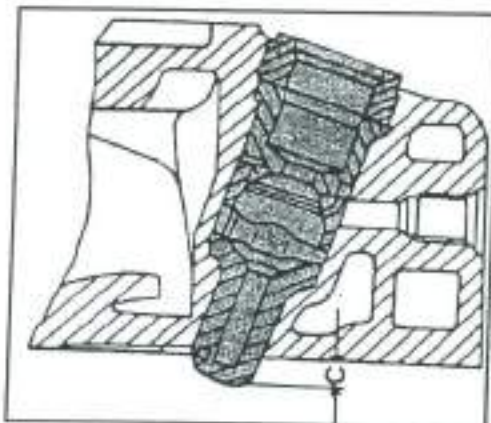

Fig. 9.13 - Dimension "C" shows the protrusion of a pre-combustion chamber above the cylinder head face.

A further check must be carried out on the pre-combustion chambers for the fuel injection. These must protrude by 5.5- 5.9 mm (0.21 - 0.23 in.), as shown by "C" in Fig. 9.13. Mercedes workshops correct this dimension by fitting sealing washers of different thicknesses, to correct the protrusion.

Camshaft: Refer to Page 27. Note the following points:

- The rocker arms must be

replaced if a new camshaft is fitted.

- Make sure to fit the correct shaft if the shaft is to be replaced. Check the identification in the shaft.

9.1.4. Cylinder Head - Assembly

The assembly of the cylinder head is a reversal of the dismantling procedure, but the following points should be noted:

- Lubricate the valve stems with engine oil and insert the valves into the correct valve guides.
- Valve stem seals are different for different engines. Make sure to order the correct seals. The repair kit contains fitting sleeves and these must be used to fit the seals. The sleeves are fitted over the valve stem before the seal is pushed in position.

- Fit the valve spring and valve spring collar over the valve and use the valve lifter to compress the spring. Fit the locknut and the dome nut in reverse order to the removal procedure. The valves must be adjusted as described in Section 9.1.5.

9.1.5. Valve Clearance - Checking and Adjusting

Mercedes workshops use special spanners to adjust the valve clearance. The clearance is adjusted on a cold engine (0.10 mm inlet valves, 0.30 mm exhaust valve). Different values apply if the clearance check is carried out on a warm engine (0.15 mm inlet valves, 0.35 mm exhaust valves).

Fig. 9.14 - Insert the feeler gauge at the position shown by the arrow to check the valve clearances. Turn the camshaft to set each cam into the position shown.

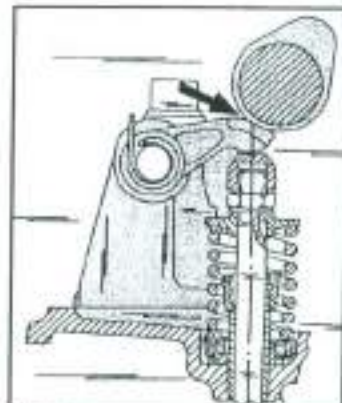

The valve clearance is checked between the rocker arm face and the cam for the respective valve, using a feeler gauge. The feeler gauge must have a tight fit. To obtain the correct valve position for the check, rotate the camshaft until the point of the cam is facing downwards, i.e. the round section of the cam must face towards the rocker arm, as shown in Fig. 9.14. The following text describes the checking and adjusting with the engine fitted. The valves should be checked, and if necessary adjusted, at intervals of 12,000 miles. Proceed as follows:

- Remove the air cleaner and the cylinder head cover.
- Use a 27 mm socket and a ratchet, place it over the crankshaft pulley bolt and rotate the engine until both valves of No. 1 cylinder are closed. Fig. 9.15 shows the position of the inlet and exhaust valves.

Fig. 9.15 - Using the two special wrenches to adjust the valve clearances.



- Apply the special wrench, shown in Fig. 9.4 to the valve spring cup. Two flats in the cup enable the wrench to be applied.
- Apply the two valve adjusting spanners to the valve in question, one to the locknut and the other one to the dome nut, as shown in Fig. 9.15, and slacken the dome nut.
- Alter the valve clearance by adjusting the dome nut. In the case of a cold engine, adjust the inlet valves to 0.10 mm (0.004 in.) and the exhaust valves to 0.30 mm (0.012 in.). If the clearances are adjusted on a warm engine, adjust the inlet valves to 0.15 mm (0.006 in.) and the exhaust valves to 0.35 mm (0.014 in.). As already mentioned,

the clearance is checked by inserting a feeler gauge into the gap shown by the arrow in Fig. 9.4. A good indication for a correct clearance is if the feeler gauge will enter without binding, then bends slightly and "jumps" into the gap.

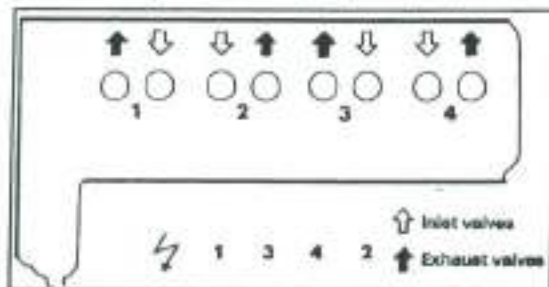

Fig. 9.16 – The position of inlet and exhaust valves.

- When the correct clearance is obtained, hold the dome nut in its position and tighten the locknut, without moving the dome nut.
- Rotate the engine until the next set of valves are fully closed and check and/or adjust as described above, following the diagram shown in Fig. 9.16.
- Carry out all other operations in reverse order to the removal procedure.

9.2 Timing Mechanism and Rocker Shafts

The component parts covered in this section can all be removed with the engine fitted to the vehicle. The endless timing chain is fitted over the camshaft sprocket, the injection pump sprocket and the crankshaft sprocket. The chain is guided by two side rails and is held under tension by means of a hydraulic chain tensioner, which is fitted to the crankcase and pushes against a light alloy tensioning rail.

The camshaft sprocket is secured to the camshaft by means of a bolt and is located by a Woodruff key.

9.2.0 Removal and Installation of Rocker Mechanism

The following points must be noted when the rocker arms are replaced:

Fig. 9.17 – The arrows show the location of the rocker arm securing screws.

- Rocker arms must be refitted to their original location if re-used.
- The camshaft must be replaced if any of the rocker arms require renewal. The removal of a rocker arm, with the engine fitted, is carried out as follows:
- Remove the cylinder head cover.

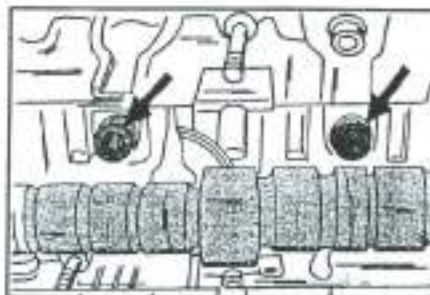

If an automatic transmission is fitted, disconnect the vacuum lines from their connections. Connections and hoses are colour-coded and must be re-connected accordingly.

- Disconnect the throttle operating linkage.
- Rotate the camshaft until all rocker arms are without tension, i.e. the cam tips must be free of the rocker arms. To rotate the engine apply a socket and a ratchet to the crankshaft pulley bolt.
- Use a suitable Allen key and remove the rocker arm pedestal bolts, shown in Fig. 9.17 by the arrows (see previous page).
- Remove the rocker arm pedestals after marking their fitted position. Sticking pedestals can be freed with a plastic or rubber mallet.

Rocker arms and camshaft have been modified during production of these engines. Quote the engine type and number when new parts are required. To replace a rocker arm, proceed as follows:

Fig. 9.18 – The position of the wire clip on the rocker arm pedestal.

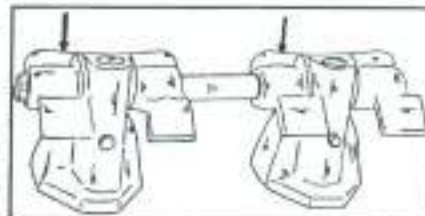

- Remove the wire clips, shown in Fig. 9.18, from the rocker arms. Referring to Fig. 9.19, remove the tension spring (5), the pedestal (3) and the rocker arms from the rocker arm shaft (6). Generously oil the new parts and refit in reverse order to the rocker arm shaft.

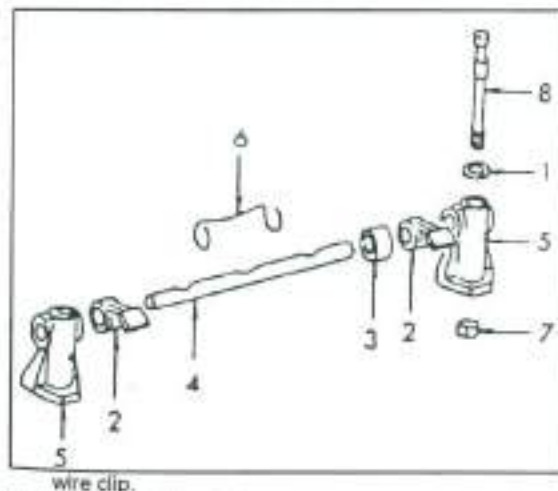

Fig. 9.19 – The component parts of the rocker shaft mounting.

- 1 Washer
- 2 Rocker arm
- 3 Bush in rocker arm
- 4 Rocker arm shaft
- 5 Rocker shaft pedestal
- 6 Wire clip
- 7 Dowel sleeve
- 8 Stretch bolt

- Fit one of the wire clip loops over the rocker arm shaft and insert the wire clip into the notch of the rocker arm shaft pedestal. Fig. 9.20 (next page) shows the fitted

Fit the rocker shafts as follows:

- Place the assembled rocker shaft assembly in position. Rocker shaft pedestals are located by dowel sleeves at the bottom faces.

- Tighten all bolts to 3.8 kgm (27.5 ft.lb.) in several stages. Check that none of the rocker arms are under tension whilst the bolts are tightened, i.e. the cams must be in a similar position as shown in Fig. 9.14.

Fig. 9.20 - The arrow shows where the wire clip is fitted to the rocker arm pedestal.



- Adjust the valve clearances as already described and refit the cylinder head cover. Tighten the nuts to 0.5 kgm (3.5 ft.lb.) or bolts to 1.5 kgm (10 ft.lb.).

9.2.1. Camshaft - Removal and Installation

Note the following points if a camshaft is to be replaced:

- If a new camshaft is fitted, also replace the rocker arms.
- The camshafts have been modified during production and not all camshafts are suitable for the earlier 616 engines. Some camshafts have cams with increased cam heights and bearing journals Nos. 2 and 3 are larger in diameter. Their diameter is 49 mm. Always quote the engine type, model year and engine number when a new camshaft is obtained. This also applies when new domed nuts are required.
- Worn camshaft bearing journals can be re-ground. Camshaft bearing shims are available in two undersizes.
- All camshafts are marked with a number in their end face. Most engines have camshafts with camshaft identification "06", earlier shafts are marked with "02".

Remove the camshaft with the engine fitted as follows:

- Drain the cooling system.
- Remove the cylinder head cover.
- Remove the rocker shaft mechanism as described in the last section and the slide rail as described in Section 9.2.4.
- Rotate the crankshaft by applying a socket and a ratchet to the crankshaft pulley bolt until the piston of No. 1 cylinder is at top dead centre firing point.
- Depending on the shape of the tensioning rail, treat the chain tensioner as follows: If the tensioning rail has the shape "A" in Fig. 9.21, remove the chain tensioner completely; if the tensioning rail has the shape "B", slacken the thrust bolt of the chain tensioner. Section 9.2.2 gives further details of these operations.
- Using paint, mark the timing chain and the camshaft sprocket at opposite points, as shown during the removal of the cylinder head.
- Insert a strong steel rod into one of the openings in the sprocket, rest the rod against the cylinder head and remove the bolt securing the camshaft sprocket to the shaft. Remove the shim.

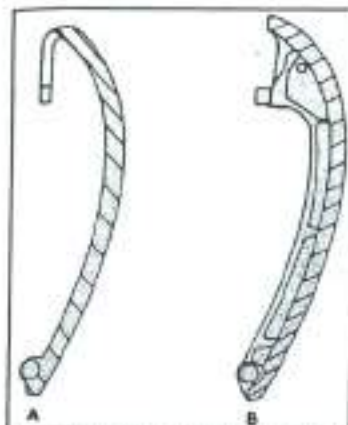

Fig. 9.21 - View of the tensioning rail. "A" shows the earlier version, "B" the later version.

- Remove the camshaft bearing cap bolts with a 10 mm Allen key one after the other. Also remove the M8 nut.
- Remove the camshaft together with the bearing caps and the oil lubrication pipe. The bearing caps are located by means of dowel sleeves and a rubber mallet may be required to free them from the cylinder head.
- Withdraw the camshaft towards the rear out of the camshaft bearing caps.

Fit the camshaft as follows:

- Coat the bearing journals, bearings and cams with engine oil and insert the camshaft from the rear into the camshaft bearings.
- Place the camshaft with the bearings and the oil lubrication pipe over the cylinder head, taking care to engage the dowel pins.
- Tighten the camshaft bearing caps. Tighten the M8 nuts to 2.5 kgm (18 ft.lb.). Turn the camshaft by hand to check for binding. If heavy spots can be found, slacken each bearing cap one after the other, every time rotating the camshaft. The "heavy" bearing can be found in this manner. Remove the camshaft and "level" the respective bearing on a surface plate with fine sandpaper.
- Fit the shim over the end of the camshaft and fit the camshaft sprocket and timing chain over the camshaft, aligning the paint marks accordingly. Insert a strong steel rod into one of the openings of the sprocket and tighten the bolt to 8.0 kgm (58 ft.lb.).
- Refit the remaining parts as described in the relevant sections, adjust the valve clearances and fit the cylinder head cover.

9.2.2. Removal and Installation of Chain Tensioner

Note the following points before removal of the chain tensioner:

- The chain tensioner must be filled with oil before installation. A faulty tensioner must always be replaced.
- Two different chain tensioners can be fitted. One type is fitted with a gasket; the other with an "O" sealing ring.

Remove the chain tensioner as follows:

- Drain the cooling system.
- Remove the thermostat housing (disconnect the coolant hoses).
- Unscrew the chain tensioner and remove. Check the "O" sealing rings, one on the shaft and the other one inside the bore (if fitted) and if necessary replace.

Refit the chain tensioner as follows. Fig. 9.22 shows where the tensioner is located, together with other parts of the timing mechanism.

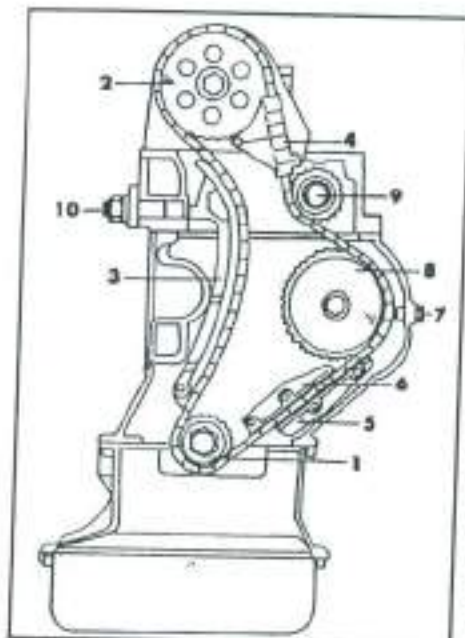

Fig. 9.22 - View of the timing mechanism.

- 1 Crankshaft timing sprocket
- 2 Camshaft timing sprocket
- 3 Tensioning rail
- 4 Slide rail
- 5 Outer slide rail
- 6 Inner slide rail
- 7 Chain arrester
- 8 Injection pump sprocket
- 9 Intermediate sprocket
- 10 Chain tensioner

- Fill the chain tensioner with oil. This requires the use of a hand press and a glass jar, filled with SAE 10 engine oil. Hold the tensioner on the thrust bolt and insert up to the flange into the oil. Using the hand press, push the thrust bolt about 7 to 10 times into the tensioner. As the tensioner is filled with oil, the pressure required to compress the tensioner will increase.

- Fit a new gasket or "O" seals and fit the chain tensioner. Tighten

the bolts evenly.

- Reft all other parts in reverse order and fill the cooling system.

9.2.3. Removal and Installation of Timing Chain

Fig. 9.22 shows the Arrangement of the timing chain. The following operations can be carried out by referring to this illustration. Note the following points before commencing any operation:

- A hand-held grinding machine must be available to replace the timing chain with the engine fitted. The new timing chain has a chain lock to connect the two chain ends.
- When an engine has been dismantled, always fit an endless timing chain.
- Before a new timing chain is fitted, check all sprockets. Worn sprocket teeth will very soon wear the new chain.
- Timing chains have been modified during the production of the engine. Always quote the engine type, engine number and model year of the vehicle.

Replace the timing chain with the engine fitted as follows:

- Unscrew the glow plugs. A special wrench of 20.8 mm across the flats is used for this operation. A 21 mm ring spanner can be used in emergency.
- Remove the cylinder head cover. Refer to Section 9.2.1 for points to be noted.
- Depending on the type of tensioning rail fitted, remove or slacken the chain tensioner (Section 9.2.2).
- Remove the compressor if an air conditioning system is fitted.

- Cover the chain chamber with rags to prevent grinding particles from falling inside and cut both chain bolts by grinding down one link of the timing chain. Do not remove the chain at this stage.
- Connect the new timing chain with the connecting link to the old chain, at the same time pushing out the old link.
- Slowly rotate the crankshaft in direction of rotation, using a 27 mm socket applied to the crankshaft pulley bolt. The timing chain must remain in engagement with the camshaft sprocket whilst the crankshaft is rotated. Do not turn the camshaft by applying a spanner to the sprocket bolt.

Fig. 9.23 - Marking of the camshaft.

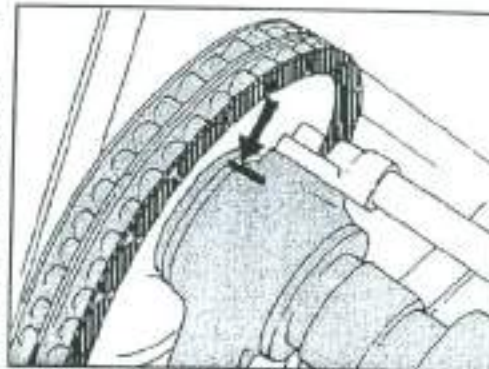

- Disconnect the old timing chain from the new chain and push the new connecting link from the inside towards the outside through the two chain ends. Secure the link with the lock washers from the front. Temporarily attach the timing chain to the camshaft sprocket (on both sides), to prevent the chain from falling into the timing chamber.
- Rotate the crankshaft until the piston of No. 1 cylinder is at TDC firing point and check that the timing marks on the camshaft sprocket are aligned as shown in Fig. 9.23. The chain is correctly fitted if this is the case. Otherwise the chain has moved by one tooth.
- Carry out all other operations in reverse order.

9.2.4 Tensioning Rail - Replacement

The location of the tensioning rail can be taken from Fig. 9.22. As already mentioned, one of two types of tensioning rails can be fitted. The second tensioning rail "B" in Fig. 9.21 can be used in place of the older type, if the rail is replaced. The new tensioning rails are marked to prevent interchanging them between a 4-cylinder and 5-cylinder engine. The rail for the engine fitted is not drilled at the top, as can be seen in Fig. 9.21, view "B". It is also wider.

A slide hammer and a threaded adaptor, to be screwed into the bearing bolt, are required to remove the tensioning rail. Remove the tensioning rail as follows:

- Remove the radiator and the cooling fan, remove the cylinder head cover (refer to Section 9.3.0 for certain details) and remove the chain tensioner if an older engine is dealt with. Remove the compressor for an air conditioning system.
- Remove the crankshaft pulley.
- Rotate the crankshaft in the direction of rotation, using a 27 mm socket and ratchet, applied to the crankshaft pulley bolt (fit the bolt back in place), until the opening in the balance disc appears opposite the bearing bolt for the tensioning rail.

- Using paint, mark the relationship between the timing chain and the crankshaft sprocket, similar, as shown in Fig. 9.2 for the camshaft sprocket and mark the camshaft sprocket and chain as shown in this illustration.
- Remove the slide rail or slide rails from the cylinder head (refer to next section).
- If the engine is fitted with the later-type tensioning rail (view "B", Fig. 9.21), push back the thrust bolt of the chain tensioner.
- Counterhold the camshaft by inserting a strong steel rod into one of the openings of the camshaft sprocket and remove the sprocket bolt. Remove the camshaft sprocket.
- Fit the slide hammer with a suitable threaded adaptor into the end of the bearing bolt and withdraw the bearing bolt by hitting the weight of the slide hammer against its stop (Fig. 9.24). Remove the tensioning rail towards the top.

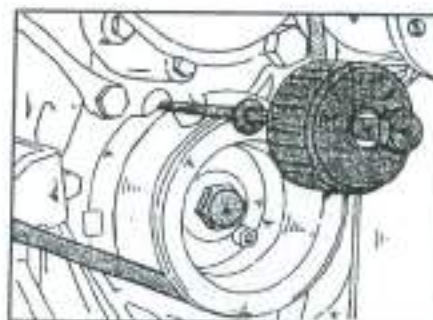

Fig. 9.24 - Removal of the bearing bolt for the tensioning rail, using an impact hammer and a threaded adaptor.

The installation of the tensioning rail is a reversal of the removal procedure. Coat the outside of the bearing bolt with sealing compound, arrange the tensioning rail in the correct position and fit the bearing bolt, again using the slide hammer. Fit the camshaft sprocket, counterhold the camshaft and tighten the camshaft sprocket bolt to 8.0 kgm

(58 ft lb.). When fitting the timing chain to the camshaft sprocket make sure that the paint marks are in line, as shown in Fig. 9.2.

9.3.5. Slide Rails - Removal and Installation

The position of the slide rails is shown in Fig. 9.22. To remove a slide rail, a slide hammer with a suitable, threaded adaptor is required, to remove the bearing bolts. The bolt is screwed into the end of the bearing bolt and the impact hammer (slide hammer) attached to the end of the bolt (Fig. 9.24). Provided that these tools can be obtained, the rails can be removed as described below. Remove the slide rail (4) in Fig. 9.22 as follows:

Fig. 9.25 - Removal of the inner slide rail (certain models).

- Remove cylinder head cover.
- Depending on the type fitted, remove the bolt shown in Fig. 9.25 and remove the bracket from the slide rail. Remove the slide rail bearing bolt with the slide hammer and the threaded adaptor and remove the outer slide rail towards the top.
- If a plastic-covered slide rail is fitted, remove the bolt and

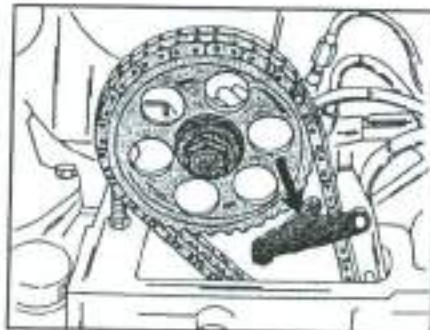

withdraw the slide rail towards the top, after the bearing bolt, has once more been withdrawn with the slide hammer, similar as shown in Fig. 9.24.

- Coat the new or original bearing bolt on the flange with sealing compound, position the slide rail in the correct position and drive in the bearing bolt. Counterhold the slide rail during the bearing bolt installation with a screwdriver to prevent distortion.
- The remaining installation is a reversal of the removal procedure.

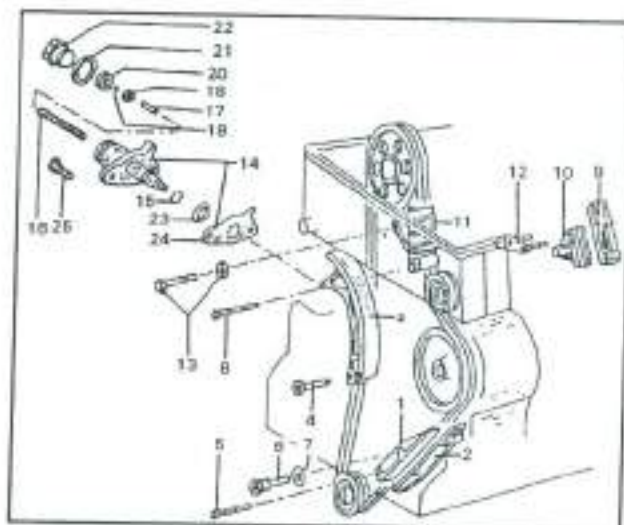

Fig. 9.25 - Exploded view of the timing mechanism.

1 Slide rail	10 Slide rail	19 Steel ball
2 Slide rail	11 Slide rail	20 Ball bearing
3 Slide rail	12 Bracket	21 Sealing ring
4 Bolt	13 Bolt/washer	22 Screw plug
5 Bolt	14 Chain tensioner	23 Sealing ring
6 Bolt	15 Retaining ring	24 Sealing washer
7 Sealing ring	16 Spring	25 Bolt
8 Bearing bolt	17 Bolt	
9 Slide rail	18 Ball bearing	

Replace the slide rail (6) in Fig. 9.22 as follows:

- Remove the radiator and the cooling fan and the vacuum pump for the operation of the brake servo unit.
- Remove the crankshaft pulley.
- Remove the cylinder head cover and the injection pump timing advancer.
- Remove the screw plug with the upper bearing bolt and remove the lower bearing bolt by means of the impact hammer and a threaded adaptor.
- Remove the slide rail towards the top.
- Coat the new or the original bearing bolt with sealing compound, position the slide rail and drive in the bearing bolt with the impact hammer. The guide lug of the slide rail must engage with the location groove in the bearing bolt.

- Carry out the remaining operations in reverse order to the removal procedures.

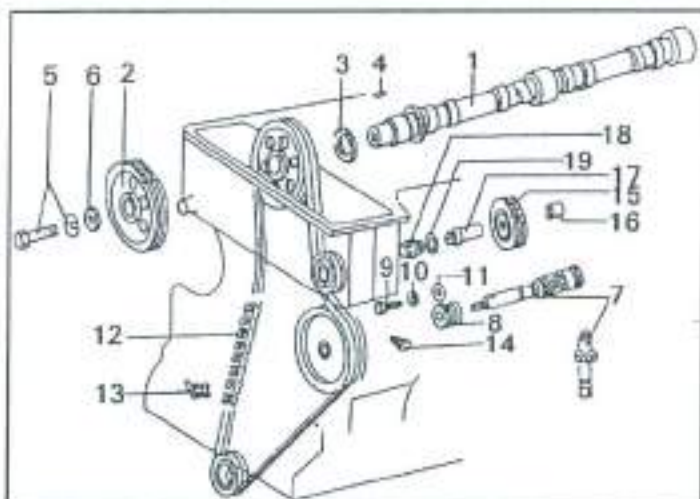

Fig. 9.27 - Exploded view of camshaft and timing chain parts.

1 Camshaft	8 Bearing	15 Tensioning sprocket
2 Camshaft sprocket	9 Bolt	16 Bush
3 Spacer washer	10 Spring washer	17 Bearing spigot
4 Woodruff key	11 Washer	18 Screw plug
5 Bolt/washer	12 Roller chain	19 Sealing ring
6 Washer	13 Chain link	
7 Intermediate shaft	14 Bolt	

Replace the slide rail (5) in Fig. 9.22 as follows:

- Remove the radiator, cooling fan and the vacuum pump for the brake servo unit.
- Remove the cylinder head cover and the injection timing advancer.
- Remove both bearing bolts for the slide rail by means of the impact hammer and a threaded adaptor and withdraw the slide rail towards the top.
- The installation of the slide rail is a reversal of the removal procedure. Coat the bearing bolts with sealing compound. Again engage the guide lug of the slide rail with the locating groove of the bearing bolt.

9.4. Lubrication System

The lubrication system is a pressure-feed system. A gear-type oil pump, consisting of an internal and an external gearwheel, is driven via the crankshaft. Fig. 9.28 shows where the pump is located at the bottom of the crankcase. The oil pump cannot be overhauled and must be replaced in case of damage.

The oil filter is fitted in upright position to the cylinder block. The oil flows through the filter element from the outside to the inside. A return shut-off valve prevents oil from flowing back through the oil pump into the oil sump when the engine is switched off. A by-pass valve opens when the pressure differential between the dirty and the clean end of the filter exceeds a certain value. The oil is then directed to the oil gallery

without being cleaned. It should be noted that the oil filter element must be changed after 600 - 1000 miles if the engine has been overhauled.

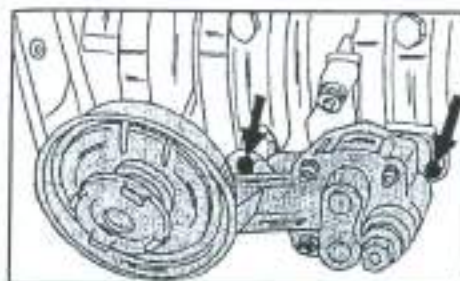

Fig. 9.28 - The oil pump at the bottom of the crankcase. The arrows show two of the bolts.

The oil sump can be removed with the engine fitted, but a lifting device must be available to lift the power unit, as the engine mountings and the crossmember must be removed.

9.4.0. Technical Data

System type and oil pump: See above
 Oil Pressure:
 At idle speed: 0.5 kg/sq. cm. (7 psi.)
 At 3000 rpm 3.0 kg/sq. cm. (43 psi.)

Engine Oil

Total capacity for refilling (dry): 7.5 litres (13.4 imp. pts.)
 Oil and filter change: 6.5 litres (11.6 imp. pts.)
 Oil sump max./min.: 5.3/3.5 litres (9.5/7.6 imp. pts.)

9.4.1. OIL PUMP - REMOVAL AND INSTALLATION

Remove the oil pump as follows:

- Remove the oil pump (Section 9.4.2.).
- The oil pump is now visible as shown in Fig. 9.28. Remove the two pump bolts from the bottom of the crankcase and withdraw the pump.

The installation of the oil pump is a reversal of the removal procedure. Thoroughly clean the oil sump and the surface on the upper oil sump case before refitting the sump. Always use a new gasket for the sump. Fill the engine with the correct quantity of the recommended oil.

9.4.2. OIL SUMP - REMOVAL AND INSTALLATION

- Place the front end of the vehicle on secure chassis stands. Remove the engine undercover and place a suitable container underneath the oil drain plug. Remove the oil drain plug and allow the oil to drain into the container. Remove the oil filter cap to speed up the draining of the oil. It also helps, if the engine oil is warm, i.e. drive the vehicle a few miles before the oil is drained.
- Using a socket and an extension remove the bolt from each of the front engine mountings (from below) and unscrew the crossmember. Make sure that the engine is securely suspended.

Fig. 9.29 – Oil filter with two filter elements.

- 1 Filter cover
- 2 Sealing ring
- 3 Filter insert
- 4 Filter element (by-pass)
- 5 Spring with spring seat
- 6 Filter housing
- 7 Sealing ring
- 8 Housing bolt

- Remove the oil dipstick tube bracket from the engine and suspend the power unit on a suitable hand crane or hoist and lift the assembly until just under tension.
- Unscrew the oil sump and lower it together with the oil dipstick tube as far as it will go. If a power-assisted steering is fitted, remove the steering pump together with the mounting bracket without disconnecting the fluid lines. The oil sump consists of two parts, which can be separated.

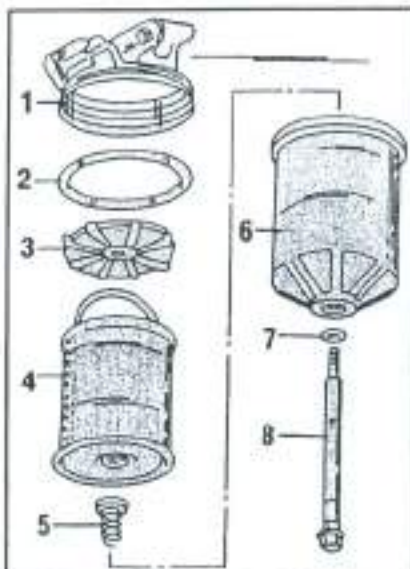

The installation of the oil sump is a reversal of the removal procedure. After fitting the crossmember and the engine mountings tighten the M10 nuts to 5.0 kgm (36 ft.lb.) and the M12 nuts (engine mountings) to 8.0 kgm (58 ft.lb.). Refit the oil dipstick tube to the engine. Finally fill the oil sump with the correct quantity of the recommended oil.

Fig. 9.30 – The component parts of an oil filter with combined filter element.

- 1 Nut
- 2 Filter housing cover
- 3 Sealing ring
- 4 Filter element
- 5 Threaded stud
- 6 Filter housing
- 7 Gasket
- 8 Intermediate plate
- 9 Spring washer
- 10 Bolt
- 11 Oil pressure switch

9.4.3. Oil Filter

The oil filter is fitted to the cylinder block on the starter motor side of the engine. Main and by-pass filter are either

separated (earlier version) or are combined. A different filter element is fitted after the engine has been overhauled, or a new or exchange engine has been fitted. The filter element can be replaced, without removing the complete filter housing. In this case, follow the instructions until the filter housing cover has been removed and pull the element out of the housing.

Replace the oil filter as follows:

- In the case of the filter shown in Fig. 9.29, remove the centre bolt from the bottom of the oil filter (next to the oil sump) and take off the filter housing. Be prepared to catch the engine oil. Remove the sealing washer.
- In the case of the filter shown in Fig. 9.30, unscrew the filter cover and carefully lift off the cover. This will allow the oil to drain back into the engine sump. Fully remove the cover and take the filter element out of the filter housing.
- Disconnect the cable for the oil pressure switch.
- If required, unscrew the oil filter housing (5 Allen headed screws). Clean the area on the cylinder block, making sure that no remnants of the old gasket can enter the oil bores in the cylinder block.
- Clean the inside of the filter housing and refit the filter and/or filter element in reverse order. Use new gaskets for the filter housing/cover. Tighten the filter housing bolts to 3.0 kgm (22 ft.lb.). Refit the filter element in accordance with the two illustrations, as applicable.
- Finally fill the engine with oil. Make sure that a good seal has been established.

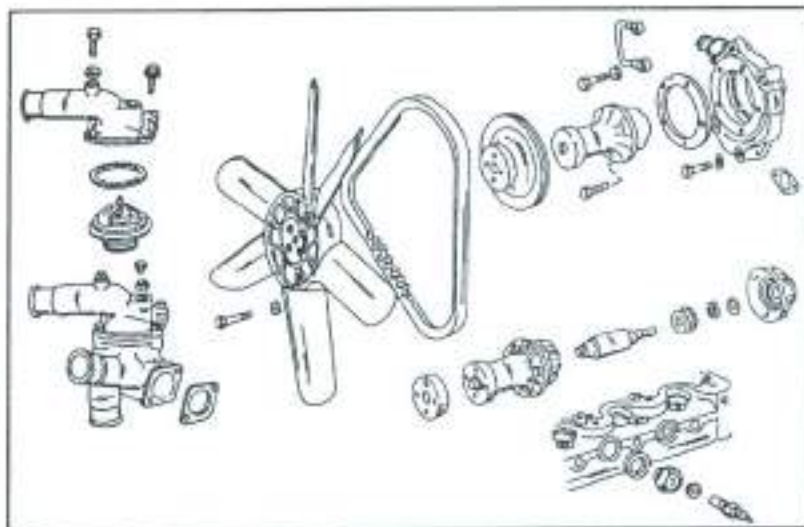

Fig. 9.31 – Water pump, thermostat and other parts of the cooling system.

9.5. Cooling System

The cooling system operates without expansion tank. The water pump is fitted to the cylinder block. A thermostat with an opening temperature of 80° C is fitted into its own housing, connected by means of a hose to the water pump.

9.5.1. Water Pump

Water pumps should not be overhauled and must be replaced in case of damage or wear. The pump is fitted to the cylinder block. Fig. 9.31 shows the water pump and associated parts. Remove the pump as follows:

- Disconnect the battery and drain the cooling system.
- Remove the cooling fan after removing the four bolts in the centre.
- Slacken the alternator tensioning link, push the alternator downwards and remove the drive belt.

Fig. 9.32 – Removal of the water pump.

- Unscrew the pump securing bolts and remove the pump from the engine. Immediately clean the pump and timing cover faces.

The installation is a reversal of the removal procedure. Place a new seal on the water pump. Install the pump so that the bleed hole points diagonally up and the drain hole vertically down. Secure the pump with new self-locking bolts and tighten the bolts to 1.0 kgm (7.2 ft.lb.).

Refit the cooling fan and adjust the water pump drive belt tension as described in the next section.

9.5.2. Drive Belt Tension

The belt must always be tensioned when water pump, alternator or crankshaft pulley have been removed. Squealing noises during acceleration also suggest that the belt must be re-tensioned.

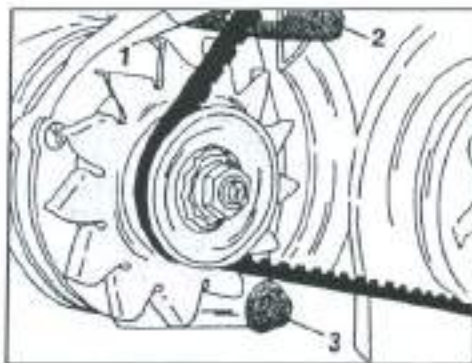

Fig. 9.33 – Bolts 1 to 3 secure the alternator to its mounting.

The tension is checked at the centre of the belt between the pulleys for the water pump and the alternator, at the point shown in Fig. 9.34.

To adjust the tension, tighten the tensioning bolt (1) in Fig. 9.34. The bolt engages into the toothed adjusting link and moves the alternator towards the outside. The belt is correctly tensioned when it can be

deflected by approx. 5 mm (1/4 in) with firm thumb pressure.

Tighten the two bolts (2) and (3) in Fig. 9.33 when the correct tension is obtained.

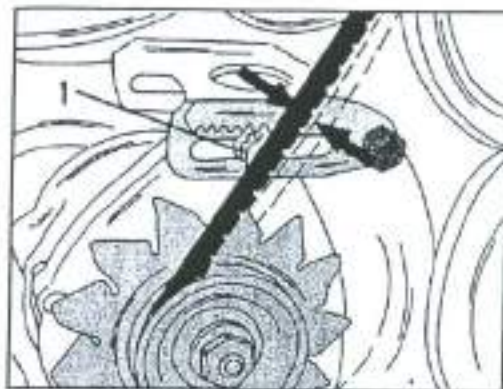

Fig. 9.34 – Tighten the tensioning bolt to tension the drive belt. The deflection of the belt is checked between the arrows.

9.5.3. Thermostat

The thermostat is located in a housing, as shown in Fig. 9.31.

The thermostat can be removed after removal of the hose at the end of the housing cover and removal of the cover. Remove the cover sealing ring. The cooling system should be drained, at least below the level of the thermostat location. Remove the sealing ring from the thermostat.

Fig. 9.35 – Correct installation of the thermostat, with the arrow pointing towards the top.

A thermostat cannot be repaired, but can be tested by immersing it in a container of cool water and gradually raising the temperature to check the opening temperature.

- Suspend the thermostat on a piece of wire so that it does not touch the sides or the bottom of the container. Suspend a thermometer in a similar manner.
- Gradually heat the water and observe the thermometer. The thermostat should begin to open at 87° C and should be fully open at 105° C. Otherwise replace the thermostat. Allow the thermostat to cool down and check if it closes properly.

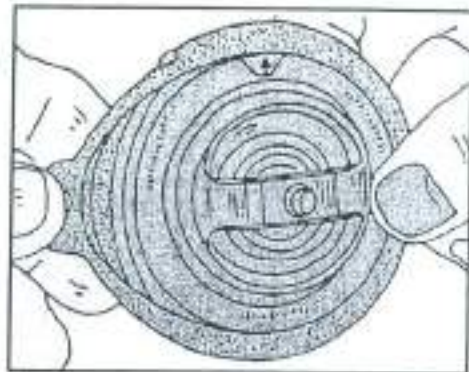

When fitting the thermostat use a new gasket. Fit the thermostat so that the arrow in the thermostat faces upwards, as shown in Fig. 9.35. This is important. Check the hose clamp before re-using it. Refill the cooling system.

NOTE: To remove the thermostat housing, proceed as above, and disconnect the hose between the thermostat housing and the water pump housing. The thermostat housing can then be unscrewed.

9.5.4. Draining and Filling the Cooling System

Refer to Section 1.8.1.

10. SERVICING AND MAINTENANCE

Most of the maintenance operations can be carried out without many difficulties. In many cases it is, however, better to have certain maintenance operations carried out in a workshop as experience and special equipment, for example test instruments, are required to carry out a certain job. Most important are the regular inspections and checks which are described below. Operations to be carried out after a certain mileage are described later on in this section and the text will advise when specific jobs should be left to a Mercedes Dealer.

10.0. Regular Maintenance

Oil Level Check: Check the engine oil level every 500 miles. With the vehicle standing on level ground, remove the oil dipstick and wipe it clean with a clean rag or a piece of tissue paper. Re-insert the oil dipstick and remove once more. The oil level must be visible between the upper and the lower mark on the dipstick. If the oil level is below the lower mark, top-up with engine oil of the correct viscosity. The oil quantity between the two marks is approx. between 5.0 and 3.5 litres and from the actual level indicated you will be able to tell how much oil is missing. Never overfill the engine - the level must never be above the upper dipstick mark.

Checking the Brake Fluid Level: - The brake fluid reservoir is in the engine compartment on the driver's side. The reservoir is transparent and it is easy to check whether the fluid level is between the "Min" and "Max" mark. If necessary, top-up to the "Max" mark with the correct brake fluid.

Checking the Brake Lights: The operation of the brake lights can either be checked with the help of another person or you can check it by yourself by driving the vehicle backwards near the garage door. Operate the brake pedal and check if the reflection of the brake lights can be seen on the garage door by looking through the rear view mirror.

Checking the Vehicle Lights: In turn check every vehicle light, including the horn and the hazard warning light system. Rear lights and reversing lights can be checked in the dark in front of a garage door, without leaving the vehicle.

Checking the Tyre Pressures: Check the tyre pressures at a petrol station. Pressures are different for the various models. Either your Operators Manual or tyre charts will give you the correct pressures.

If continuous speeds of more than 100 mph are anticipated, increase the tyre pressure by 0.2 kg/sq cm. (3 psi.)

Checking the Coolant Level: See Section 1.8.1. Never open the radiator filler cap when the engine is hot.

Checking the Fluid Level in the Automatic Transmission: The fluid level should be checked at regular intervals to ensure the correct operation of the transmission:

- Apply the handbrake and place the gear selector lever into the "P" position. Start the engine and allow to idle for 1 to 2 minutes.
- Remove the oil dipstick from the transmission and read off the fluid level. The level must be between the "Min" and "Max" mark when the transmission is at operating temperature; the level may be up to 10 mm (0.4 in.) below the "Min" mark if the transmission is cold.
- If necessary top-up the transmission with ATF fluid through the fluid dipstick tube. A funnel is required. Only use the fluid recommended for the transmission.

10.1. Service every 6000 Miles

Changing the Engine Oil and Oil Filter:- Some petrol stations will carry out an oil change free of charge - You only pay for the oil. The same applies to the oil filter (there may be a small extra charge), but not every petrol station will be able to obtain a Mercedes filter. To change the filter yourself, refer to Page 81 or to the relevant section at the end of the manual, when a 2.4 litre engine (616) is fitted. The engine oil change is also described on Page 81.

Lubrication Jobs: Apart from the engine lubrication there are further lubrication points which should be attended to. These include the throttle linkage and shafts (only grease the swivel points), the engine bonnet catch and the hinges (use a drop of engine oil) and perhaps the door mechanism.

10.2. Additional Service Every 12,000 Miles

Checking the Idle Speed: If the engine no longer idles as expected, have the idle speed checked and if necessary adjusted at your Dealer.

Air Filter Service: Remove the air filter element for cleaning, as described on Page 104.

Checking the Brake System: If no trouble has been experienced with the brake system, there is little need to carry out extensive checks. To safeguard for the next 6000 miles, however, follow the brake pipes underneath the vehicle. No rust or corrosion must be visible. Dark deposits near the pipe ends point to leaking joints. Brake hoses must show no signs of chafing or breaks. All rubber dust caps must be in position on the bleeder valves of the calipers. Insert a finger underneath the master cylinder, where it is fitted to the brake servo unit. Moisture indicates a slightly leaking cylinder.

The brake pads must be checked for the remaining material thickness as has been described in Section "Brakes" for the front and rear brakes.

Adjusting the Parking Brake: Adjust the parking brake as described in Section "Brakes" under the relevant heading.

Brake Test: A brake test is recommended at this interval. You will decide yourself if the brakes perform as you expect them to. Otherwise have the brakes tested on a dynamometer. The read-out of the meter will show you the efficiency of the brake system on all four wheels.

Checking the Wheel Suspension and Steering: In the case of the front suspension remove both wheels and check the shock absorbers for signs of moisture, indicating fluid leaks.

Check the free play of the steering wheel. If the steering wheel can be moved by more than 25 mm (1 in.) before the front wheels respond, have the steering checked professionally.

Check the rubber dust boots of the track rod and drag link ball joints. Although rubber boots can be replaced individually, dirt may have entered the joints already. In this case replace the ball joint end piece.

Check the oil level in the mechanical steering. Remove the filler plug and check if the oil level is up to the filler plug bore hole. If necessary top-up with the recommended oil.

If a power-assisted steering is fitted, check the fluid level in the reservoir. Refer to Section 6.2.2. for details. If steering fluid is always missing after the 12,000 miles check, suspect a leak somewhere in the system - See your dealer.

Tyre Check: Jack up the vehicle and check all tyres for uneven wear. Tyres should be evenly worn on the entire surface. Uneven wear at the inner or outer edge of front tyres points to misalignment of the front wheel geometry. Have the geometry measured at your dealer. Make sure that a tread depth of 1.6 mm is still visible to remain within the legal requirements. Make sure to fit tyres suitable for your model, mainly if you buy them from an independent tyre company.

Re-tighten Wheel Bolts:- Re-tighten the wheel bolts to 16.0 - 18.0 kgm (115 - 130 ft.lb.). Tighten every second bolt in turn until all bolts have been re-tightened.

Checking the Cooling System: Check all coolant hoses for cuts, chafing and other damage. Check the radiator for leaks, normally indicated by a deposit, left by the leaking anti-freeze. Slight radiator leaks can be stopped with one of the proprietary sealants available for this purpose.

Checking the Clutch: Check the clutch operation. The fluid reservoir should be full. If it is suspected that the clutch linings are worn near their limit, take the vehicle to a dealer. A gauge is used to check the protrusion of the slave cylinder push rod. It is a quick check and may prevent the clutch driven plate to wear down to the rivets.

Checking the Anti-freeze: The strength of the anti-freeze should be checked every 12,000 miles. Petrol stations normally have a hydrometer to carry out this check. Make sure that only anti-freeze suitable for Mercedes engines is used.

Checking the Manual Transmission Fluid Level: Refer to Section 3.3. on page 118.

Checking the Rear Axle Oil Level: Refer to Section 5.3, Page 139.

10.3. Additional Service every 36,000 Miles

Automatic Transmission Oil and Filter Change: These operations should be carried out by a Dealer.

Air Cleaner Element Change: Refer to Section 1.9.8 on Page 104.

Diesel Oil Filter- Change: Replace the fuel filter as described in Section 1.9.1 on Page 93. Bleed the fuel system.

Clutch: The wear of the clutch driven plate should be checked by a dealer with the special gauge available.

10.4. Once every Year

Brake Fluid Change: We recommend to have the brake fluid changed at your dealer. Road safety is involved and the job should be carried out professionally. If you are experienced with brake systems, follow the instructions in the "Brakes" section to drain, fill and bleed the brake system.

10.5. Once every 3 Years

Cooling System: The anti-freeze must be changed. Refer to Section 1.8.1. to drain and refill the cooling system.

FAULT FINDING SECTION

The following section lists some of the more common faults that can develop in a motor car, both for petrol and diesel engines. For the purpose of this manual, references to diesel engines are of course, first and foremost. The section is divided into various categories and it should be possible to locate faults or damage by referring to the assembly group of the vehicle in question.

The faults are listed in no particular order and their causes are given a number. By referring to this number it is possible to read off the possible

cause and to carry out the necessary remedies, if this is within the scope of your facilities.

ENGINE FAULTS

Engine will not crank:	1, 2, 3, 4
Engine cranks, but will not start:	5, 6, 7, 8
Engine cranks very slowly:	1, 2, 3
Engine starts, but cuts out:	5, 6, 9, 10
Engine misfires in the lower speed ranges:	5, 6, 9, 11
Engine misfires in the higher speed ranges:	5, 6, 11, 12
Continuous misfiring:	5, 6, 7, 10 to 15, 21, 22
Max. revs not obtained:	5, 6, 12, 22
Faulty idling:	5, 6, 8 to 11, 13, 15, 16, 21 and 22
Lack of power:	3, 5 to 11, 13 to 15, 22
Lack of acceleration:	5 to 8, 12, 14 to 16
Lack of max. speed:	5 to 8, 10, 12, 13 to 15, 22
Excessive fuel consumption:	3, 5, 6, 15, 16
Excessive oil consumption:	16 to 19
Low compression:	7, 11 to 13, 16, 20 to 22

CAUSES AND REMEDIES

1. Fault in the starter motor or its connection. Refer to "Electrical Faults".
2. Engine oil too thick. This can be caused by using the wrong oil, low temperatures or using oil not suitable for the prevailing climates. Depress the clutch whilst starting (models with manual transmission). Otherwise refill the engine with the correct oil grade, suitable for diesel engines.
3. Moveable parts of the engine not run-in. This fault may be noticed when the engine has been overhauled. It may be possible to free the engine by adding oil to the fuel for a while.
4. Mechanical fault. This may be due to seizure of the piston(s), broken crankshaft, connecting rods, clutch or other moveable parts of the engine. The engine must be stripped for inspection.
5. Faults in the glow plug system. Refer to "Glow Plug Faults".
6. Faults in the fuel system. Refer to "Fuel Faults".
7. Incorrect valve timing. This will only be noticed after the engine has been reassembled after overhaul and the timing belt has been replaced incorrectly. Re-dismantle the engine and check the timing marks on the timing gear wheels.
8. Compression leak due to faulty closing of valves. See also under (7) or leakage past worn piston rings or pistons. Cylinder head gasket blown.
9. Entry of air at inlet manifold, due to split manifold or damaged gasket.
10. Restriction in exhaust system, due to damaged exhaust pipes, dirt in end of exhaust pipe(s), kinked pipe(s), or collapsed silencer. Repair as necessary.

11. Worn valves or valve seats, no longer closing the valves properly. Top overhaul of engine is asked for.
12. Sticking valves due to excessive carbon deposits or weak valve springs. Top overhaul is asked for.
13. Cylinder head gasket blown. Replace gasket and check block and head surfaces for distortion.
14. Camshaft worn, not opening or closing one of the valves properly, preventing proper combustion. Check and if necessary fit new camshaft.
15. Incorrect valve (tappet) clearance. There could be a fault in the hydraulic tappets.
16. Cylinder bores, pistons or piston rings worn. Overhaul is the only cure. Fault may be corrected for a while by adding "Piston Seal Liquid" into the cylinders, but will re-develop.
17. Worn valve guides and/or valve stems. Top overhaul is asked for.
18. Damaged valve stem seals. Top overhaul is asked for.
19. Leaking crankshaft oil seal, worn piston rings or pistons, worn cylinders. Correct as necessary.
20. Loose glow plugs, gas escaping past thread or plug sealing washer damaged. Correct.
21. Cracked cylinder or cylinder block. Dismantle, investigate and replace block, if necessary.
22. Broken, weak or collapsed valve spring(s). Top overhaul is asked for.

GLOW PLUG FAULTS

Check a suspect glow plug as follows:

- Remove the glow plug lead from the rear glow plug and from the remaining plugs the bus bars.
 - Connect a 12 volts test lamp to the plus terminal of the battery and with the other lead of the lamp touch in turn the connecting threads of each glow plug. The faulty plug is detected when the test lamp does not light up.
- Further faults in the glow plug system can develop in the glow plug relay. Check as follows:
- Disconnect the electrical lead from the glow plug on the flywheel end and connect a test lamp between the lead and a good earthing point.
 - Disconnect the electrical lead from the coolant temperature sender unit and move away from earth.
 - Turn the ignition key to the "glowing" position and observe the test lamp. The lamp should light up for approx. 25 - 30 sec. and then switch off.
 - Turn the ignition switch 'off' and then again to the "glowing" position. The test lamp must light up once more.
 - Hold the disconnected lead from the temperature sender unit against earth. The test lamp must switch off.
 - Turn the ignition switch 'off' and then again to the "glowing" position. The test lamp should light up.
 - Operate the starter motor and check that the test lamp remains "on".
 - If the above tests cannot be carried out satisfactory, see your dealer.

LUBRICATION SYSTEM FAULTS

The only problem the lubrication system should give is excessive oil consumption or low oil pressure, or the oil warning light not going off.

Excessive oil consumption can be caused by worn cylinder bores, pistons and/or piston rings, worn valve guides, worn valves stem seals or a damaged crankshaft oil seal or leaking gasket on any of the engine parts. In most cases the engine must be dismantled to locate the fault.

Low oil pressure can be caused by a faulty oil pressure gauge, sender unit or wiring, a defective relief valve, low oil level, blocked oil pick-up pipe for the oil pump, worn oil pump or damaged main or big end bearings. In most cases it is logical to check the oil level first. All other causes require the dismantling and repair of the engine. If the oil warning light stays on, switch off the engine IMMEDIATELY, as delay could cause complete seizure within minutes.

COOLING SYSTEM FAULTS

Common faults are: Overheating, loss of coolant and slow warming-up of the engine.

Overheating:

1. **Lack of coolant:** Open the radiator cap with care to avoid injuries. Never pour cold water in to an overheated engine. Wait until engine cools down and pour in coolant whilst engine is running.
2. **Radiator core obstructed by leaves, insects, etc.:** Blow with air line from the back of the radiator or with a water hose to clean.
3. **Cooling fan not operating:** Check fan for proper cut-in and cut-out temperature. If necessary change the temperature switch or see your Dealer.
4. **Thermostat sticking:** If sticking in the closed position, coolant can only circulate within the cylinder head or block. Remove thermostat and check as described in section "Cooling".
5. **Water hose split:** Identified by rising steam from the engine compartment or the front of the vehicle. Slight splits can be repaired with insulation tape. Drive without expansion tank cap to keep the pressure in the system down, to the nearest service station.
6. **Water pump belt torn:** Replace and tension belt.
7. **Water pump inoperative:** Replace water pump.
8. **Cylinder head gasket blown:** Replace the cylinder head gasket.

Loss of Coolant:

1. **Radiator leaks:** Slight leaks may be stopped by using radiator sealing compound (follow the instructions of the manufacturer. In emergency an egg can be cracked open and poured into the radiator filler neck.
2. **Hose leaks:** See under 5, "Overheating".

3. **Water pump leaks:** Check the gasket for proper sealing or replace the pump.

Long Warming-up periods:

1. **Thermostat sticking in the open position:** Remove thermostat, check and if necessary replace.

DIESEL FUEL SYSTEM FAULTS

Engine is difficult to start or does not start	1 to 13
Engine starts, but stop soon afterwards:	14 to 20
Engine misfires continuously:	1 to 13
Bad idling:	14 to 20
Black, white or blue exhaust smoke:	21 to 29
Lack of power:	30 to 39
Excessive fuel consumption:	40 to 47

CAUSES AND REMEDIES

1. Fuel tank empty. Refuel.
2. Pre-glowing time too short. Operate until warning light goes "off".
3. Cold starting device not operated. Pull cable and push in after approx. 1 mm.
4. Glow plug system inoperative. Refer to "Glow Plug Faults".
5. Electro-magnetic cut-off device, loose or no current. Check cable to cut-off at top of injection pump. Ask a second person to operate ignition key and check if a "click" is heard. Either interrupted current supply or defective cut-off device.
6. Air in fuel system. Operate starter motor until fuel is delivered.
7. Fuel supply faulty. Slacken the injection pipes at injectors, and check if fuel is running out. Other faults: kinked, blocked or leaking injection pipes blocked fuel filter, tank breathing system blocked. Wrong fuel for cold temperatures.
8. Injection pipes refilled in wrong order after repair.
9. Injection timing of pump out of phase: Have the adjustment checked and corrected.
10. One or more injectors faulty, dirty or incorrect injection pressure. Have injectors repaired or replace them.
11. Injection pump not operating properly. Fit an exchange pump or have it repaired.
12. Valves not opening properly.
13. Compression pressures too low. See item "8" under "Engine Faults".
14. Idle speed not properly adjusted. Adjust.
15. Throttle cable not properly adjusted or sticking. Re-adjust or free-off.
16. Fuel hose between filter and pump not tightened properly. Tighten connections.
17. Rear mounting of injection pump loose or cracked. Tighten or replace.

18. See items 6, 7, 9, 11, 12 and 13
19. Engine mounting not tightened properly or worn. Tighten or replace.
20. Sticking accelerator pedal. Free-off pedal.
21. Engine not at operating temperature. Check exhaust smoke colour again when engine is warm
22. Too much acceleration at low revs. Use individual gears in accordance with acceleration.
23. Air cleaner contaminated. Clean or replace.
24. Fuel filter contaminated. Replace.
25. Max. speed adjustment incorrect. Re-adjust.
26. Injectors are dripping. Have them checked or replace faulty ones.
27. Injector nozzles sticking or broken. Replace injector.
28. Injection pressure too low. Have injectors checked and adjusted.
29. See items 9, 11, 12 and 13
30. Throttle cable travel restricted. Re-adjust. Check that floor mats cannot obstruct pedal movement.
31. Throttle cable not correctly adjusted. Re-adjust.
32. Operating lever loose on pump. Re-tighten.
33. Max. speed not obtained. Re-adjust max. speed or have it adjusted.
34. Injector pipes restricted in diameter (near connections). Disconnect pipes and check that diameter is at least 2.0 mm (0.08 in.).
35. Heat protection sealing gaskets under injectors not sealing or damaged. Remove injectors and check. Replace if necessary. Fit the washers correctly.
36. Injection pressure of injectors wrong. Have them re-adjusted.
37. See items 6, 7, 9, 11 and 13
38. See item 20
39. See items 23, 24, 26 and 27.
40. Road wheels dragging. Brakes seized or wheel bearings not running freely.
41. Engine not running "free". Refers to new or overhauled engine.
42. Fuel system leaking. Check hoses, pipes, filter, injection pump, etc. for leaks.
43. Fuel return line blocked. Clean with compressed air if possible.
44. Idle speed too high. Re-adjust.
45. Max. speed too high. Re-adjust.
46. See items 10, 11, 12 and 13.
47. See items 24, 26, 27 and 28.

CLUTCH FAULTS

Clutch slipping:	1, 2, 3, 4, 5
Clutch will not disengage fully:	4, 6 to 12, 14
Whining from clutch when pedal is depressed:	13
Clutch judder:	1, 2, 7, 10 to 13
Clutch noise when idling:	2, 3
Clutch noise during engagement:	2

CAUSES AND REMEDIES

1. Insufficient clutch free play at pedal.
 2. Clutch disc linings worn, hardened, oiled-up, loose or broken. Disc distorted or hub loose. Clutch disc must be replaced.
 3. Pressure plate faulty. Replace clutch.
 4. Air in hydraulic system. Low fluid level in clutch cylinder reservoir.
 5. Insufficient play at clutch pedal and clutch release linkage. Rectify as described.
 6. Excessive free play in release linkage (only for cable operated clutch, not applicable). Adjust or replace worn parts.
 7. Misalignment of clutch housing. Very rare fault, but possible on transmissions with separate clutch housings. Re-align to correct.
 8. Clutch disc hub binding on splines of main drive shaft (clutch shaft) due to dirt or burrs on splines. Remove clutch and clean and check splines.
 9. Clutch disc linings loose or broken. Replace disc.
 10. Pressure plate distorted. Replace clutch.
 11. Clutch cover distorted. Replace clutch.
 12. Fault in transmission or loose engine mountings.
 13. Release bearing defective. Remove clutch and replace bearing.
 14. A bent clutch release lever. Check lever and replace or straighten, if possible.
- The above faults and remedies are for hydraulic and mechanical clutch operation and should be read as applicable to the model in question, as the clutch fault finding section is written for all types of clutch operation.

STEERING FAULTS

Steering very heavy:	1 to 6
Steering very loose:	5, 7 to 9, 11 to 13
Steering wheel wobbles:	4, 5, 7 to 9, 11 to 16
Vehicle pulls to one side:	1, 4, 8, 10, 14 to 18
Steering wheel does not return to centre position:	1 to 6, 18
Abnormal tyre wear:	1, 4, 7 to 9, 14 to 19
Knocking noise in column:	6, 7, 11, 12

CAUSES AND REMEDIES

1. Tyre pressures not correct or uneven. Correct.
2. Lack of lubricant in steering
3. Stiff steering linkage ball joints. Replace ball joints in question.
4. Incorrect steering wheel alignment. Correct as necessary.
5. Steering needs adjustment. See your dealer for advice.
6. Steering column bearings too tight or seized or steering column bent. Correct as necessary.
7. Steering linkage joints loose or worn. Check and replace joints as

necessary.

8. Front wheel bearings worn, damaged or loose. Replace bearing.
9. Front suspension parts loose. Check and correct.
10. Wheel nuts loose. Re-tighten.
11. Steering wheel loose. Re-tighten nut.
12. Steering gear mounting loose. Check and tighten.
13. Steering gear worn. Replace the steering gear.
14. Steering track rods defective or loose.
15. Wheels not properly balanced or tyre pressures uneven. Correct pressures or balance wheels.
16. Suspension springs weak or broken. Replace spring in question or both.
17. Brakes are pulling to one side. See under "Brake Faults".
18. Suspension out of alignment. Have the complete suspension checked by a dealer.
19. Improper driving. We don't intend to tell you how to drive and are quite sure that this is not the cause of the fault.

BRAKE FAULTS

Brake Failure: Brake shoe linings or pads excessively worn, incorrect brake fluid (after overhaul), insufficient brake fluid, fluid leak, master cylinder defective, wheel cylinder or caliper failure. Remedies are obvious in each instance.

Brakes ineffective: Shoe linings or pads worn, incorrect lining material or brake fluid, linings contaminated, fluid level low, air in brake system (bleed brakes), leak in pipes or cylinders, master cylinder defective. Remedies are obvious in each instance.

Brakes pull to one side: Shoes or linings worn, incorrect linings or pads, contaminated linings, drums or discs scored, fluid pipe blocked, unequal tyre pressures, brake back plate or caliper mounting loose, wheel bearings not properly adjusted, wheel cylinder seized. Rectify as necessary.

Brake pedal spongy: Air in hydraulic system. System must be bled of air.

Pedal travel too far: Linings or pads worn, drums or discs scored, master cylinder or wheel cylinders defective, system needs bleeding. Rectify as necessary.

Loss of brake pressure: Fluid leak, air in system, leak in master or wheel cylinders, brake servo not operating (vacuum hose disconnected or exhaust pump not operating). Place vehicle on dry ground and depress brake pedal. Check where fluid runs out and rectify as necessary.

Brakes binding: Incorrect brake fluid (boiling), weak shoe return springs, basic brake adjustment incorrect (after fitting new rear shoes), piston in caliper of wheel cylinder seized, push rod play on master cylinder insufficient (compensation port obstructed), handbrake adjusted too tightly. Rectify as necessary. Swelling of cylinder cups through use of incorrect brake fluid could be another reason.

Handbrake ineffective: Brake shoe linings worn, linings contaminated, operating lever on brake shoe seized, brake shoes or handbrake need adjustment. Rectify as necessary.

Excessive pedal pressure required: Brake shoe linings or pads worn, linings or pads contaminated, brake servo vacuum hose (for brake servo) disconnected or wheel cylinders seized. Exhauster pump not operating. Rectify as necessary.

Brakes squealing: Brake shoe linings or pads worn so far that metal is grinding against drum or disc. Inside of drum is full of lining dust. Remove and replace, or clean out the drum(s). Do not inhale brake dust.

Note: Any operation on the steering and brake systems must be carried out with the necessary care and attention. Always think of your safety and the safety of other road users. Make sure to use the correct fluid for the power-assisted steering and the correct brake fluid.

Faults in an ABS system should be investigated by a dealer.

Change the brake fluid in regular intervals (approx. every 1 year).

ELECTRICAL FAULTS

Starter motor failure:	2 to 5, 6, 9
No starter motor drive:	1 to 3, 5 to 7
Slow cranking speed:	1 to 3
Charge warning light remains on:	3, 10, 12
Charge warning light does not come on:	2, 3, 9, 11, 13
Headlamp failure:	2, 3, 11, 13, 14
Battery needs frequent topping-up:	11
Direction indicators not working properly:	2, 3, 9, 13, 14
Battery frequently discharged:	3, 10, 11, 12

CAUSES AND REMEDIES

1. Tight engine. Check and rectify.
2. Battery discharged or defective. Re-charge battery or replace if older than approx. 2 years.
3. Interrupted connection in circuit. Trace and rectify.
4. Starter motor pinion jammed in flywheel. Release.
5. Also 6, 7 and 8. Starter motor defective, no engagement in flywheel, pinion or flywheel worn or solenoid switch defective. Correct as necessary.
9. Ignition/starter switch inoperative. Replace.
10. Drive belt loose or broken. Adjust or replace.
11. Regulator defective. Adjust or replace.
12. Generator inoperative. Overhaul or replace.
13. Bulb burnt out. Replace bulb.
14. Flasher unit defective. Replace unit.

Pages 191 - 192 - Wiring Diagrams

- | | |
|-------------------------------------|--------------------------------------|
| 1 L.H. indicator | e = Oil pressure |
| 2 L.H. headlamp | f = Heated rear screen |
| 56a Main beam | g = Rear fog lamp |
| 56b Dipped beam | h = Alternator charging |
| 58 Side light | 35 Interior lamp with switch |
| 31 Earth | 36 Relay, heated rear screen |
| 3 L.H. fog lamp | 37 Relay, brake fluid level |
| 4 Horn | 38 Glow plug warning lamp |
| 5 R.H. fog lamp | 39 Resistor |
| 6 R.H. headlamp | 40 Contact switch, brake fluid level |
| 56a, 56b, 58 and 31 as above | 41 Ignition switch |
| 7 R.H. indicator lamp | 42 Switch, reversing light |
| 8 Fog lamp relay | 43 Cable connector |
| 9 Windscreen wiper motor | 44 Ignition lock |
| 10 Front interior light with switch | 45 Alternator |
| 11 Tachograph | 46 Starter motor |
| 12 Speedometer | 47 Oil pressure switch |
| 13 Coolant temperature indicator | 48 Battery |
| 14 Fuel gauge | 49 R.H. rear lights: |
| 15 Tank sender unit | a = Reversing light |
| 16 Temperature sender unit | b = Brake light |
| 17 Socket | c = Rear light |
| 18 Door contact switch | d = Indicator lamp |
| 19 Heater blower motor | 50 Heated rear screen |
| 20 Switch for 19 | 51 Number plate light |
| 21 Fog lamp switch | 52 Socket, trailer |
| 22 Rear fog lamp switch | 53 Rear fog lamp |
| 23 Switch, heated rear screen | 54 L.H. rear lights: |
| 24 Light switch | a, b, c and d as above |
| 25 Wiper switch | |
| 26 Fuses | |
| 27 Switch, hazard warning | |
| 28 Brake light switch | |
| 29 Connections to socket | |
| 30 Glow plugs | |
| 31 Combined switch | |
| 32 Warning light switch | |
| 33 Interior light with switch | |
| 34 Warning lamps: | |
| a = Indicator lamp, trailer | |
| b = Indicator lamp, vehicle | |
| c = Brake fluid | |
| d = Main beam | |

Cable Colour Code

- bl = blue
br = brown
el = ivory
ge = yellow
gn = green
l = violet
rs = pink
rl = red
sw = black
ws = white

Pages 191 - 197 - Legend - Diagrams 1 to 6

- | | |
|-------------------------------|----------------------------|
| 1 Starter motor, power supply | H1 Charge warning light |
| A1 Steering lock | H2 Glow plug warning light |
| B1 Sensor, temperature | K1 Glow plug relay |
| G1 Battery | M1 Starter motor |
| G2 Alternator | R1 Glow plug |

- S1 Battery main switch
X2 Connectors

- 2 Light switch, rear fog lamp, number plate light, rear lights, parking lights and fog lamps

- E1 R.H. parking light
E2 R.H. rear light
E3 Number plate light
E4 Number plate light
E5 Rear fog lamp
E10 L.H. fog lamp
E11 R.H. fog lamp
F1 Fuse
F9 Fuse
F10 Fuse
Q1 Light switch
X1 Trailer light socket
X2 Trailer light socket

- 3 Parking light, rear lights, trailer light socket

- E6 L.H. parking light
E7 L.H. rear light
F8 Fuse
S2 Combination switch

- X1 Trailer light socket

- 4 Headlamp
E8 L.H. headlamp
E9 R.H. headlamp
F11 Fuse
F12 Fuse
F13 Fuse
F14 Fuse
K3 Main beam warning light

- 6 Warning lamps, hazard warning lights
F6 Fuse
H4 Indicator warning light, trailer
H5 Indicator warning light, vehicle
K2 Relay, hazard warning lights
S2 Combination switch
S3 Hazard warning light switch

- 8 Indicator lamps
H6 R.H. front side indicator lamp
H7 R.H. front indicator lamp
H8 R.H. rear indicator lamp
H9 L.H. rear light
H10 L.H. front indicator lamp
H11 L.H. front side indicator lamp
X1 Trailer light socket

Wiring Diagram Legend - 7 to 15 - 210D/410D

- 7 Windscreen wipers, washer system

- K3 Windscreen wiper switch
M2 Windscreen wiper motor
M3 Windscreen washer pump
S2 Combination switch

- 8 Brake lights, horn

- B2 Brake light switch
B3 Horn switch
E12 L.H. brake light
E13 R.H. brake light
F4 Fuse
H12 Horn
X1 Trailer light socket

- 9 Heater blower motor
M4 Heater blower motor
S4 Heater blower motor switch

- 10 Fuel, coolant system
B4 Tank sender unit
B5 Temperature sender unit
P1 Fuel feed
P2 Temperature gauge

- 11 Reversing lights
E14 L.H. reversing light
E15 R.H. reversing light
F5 Fuse
S5 Reversing light switch

- 12 Speedometer, tachograph, clock
E16 Heater control illuminations
P3 Speedometer
P4 Clock
P5 Tachograph

- 13 Door contact switches, interior lights, sockets
- E17 Cargo room lamp
- F2 Fuse
- H13 Interior light
- S8 Cargo room lamp switch
- X3 Socket, drivers compartment

- 14 Heated rear screen, test socket for fuses
- B6 Switch, heated rear screen
- F16 Fuse
- H14 Indicator lamp, socket for fuse test
- R2 Heated rear screen
- R3 Heated rear screen
- X4 Test socket for fuses

- 16 Parking lights, brake pad wear, brake fluid, engine oil pressure
- S9 Sensor, brake lining wear, L.H.

- rear
- S10 Sensor, brake lining wear, R.H. rear
- S11 Sensor, brake pad wear, L.H. front
- S12 Sensor, brake pad wear, R.H. front
- B7 Switch, fluid level indicator switch
- B8 Oil pressure switch
- S13 Switch, differential lock
- E18 L.H. front parking light
- E19 R.H. front parking light
- E20 L.H. rear parking light
- E21 R.H. rear parking light
- F15 Fuse
- H16 Warning light, brake pads and brake fluid
- H17 Oil pressure warning light
- H18 Warning light, differential lock
- K4 Relay, D+
- V1 Diode
- X1 Trailer light socket

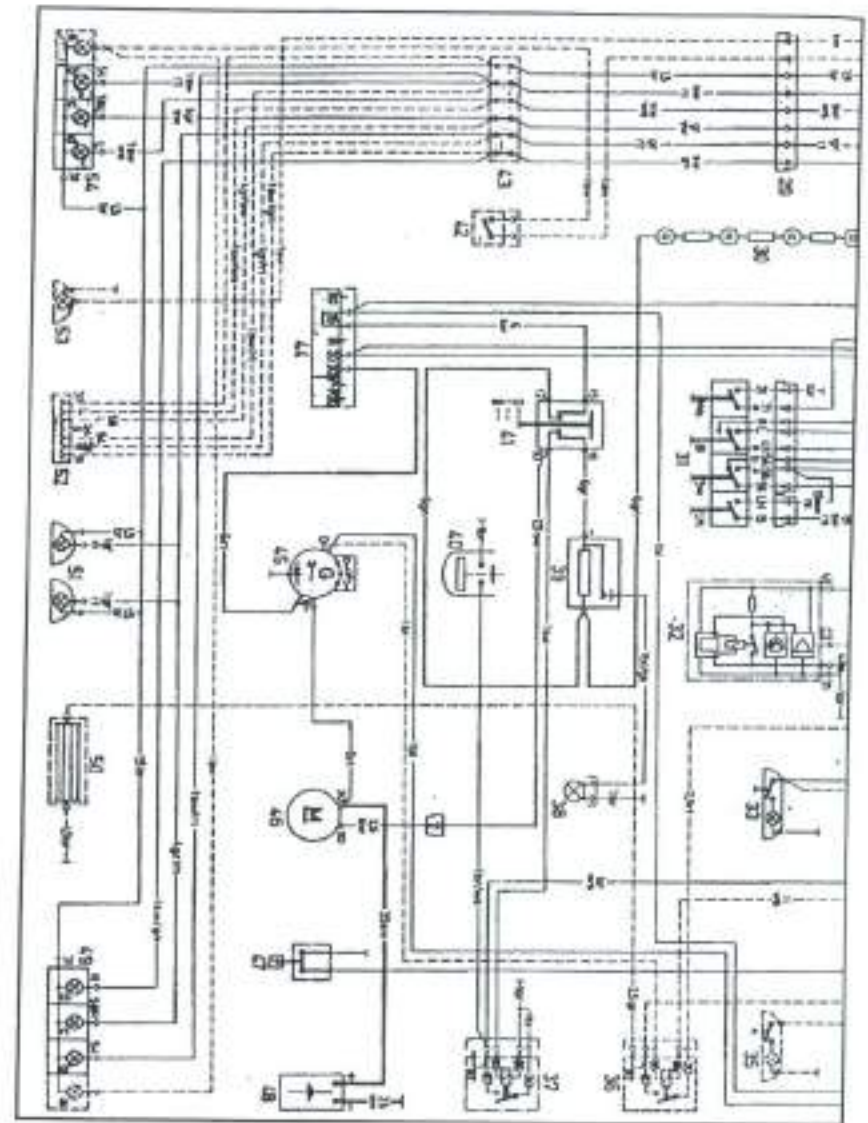

Legend - See Pages 188 to 189

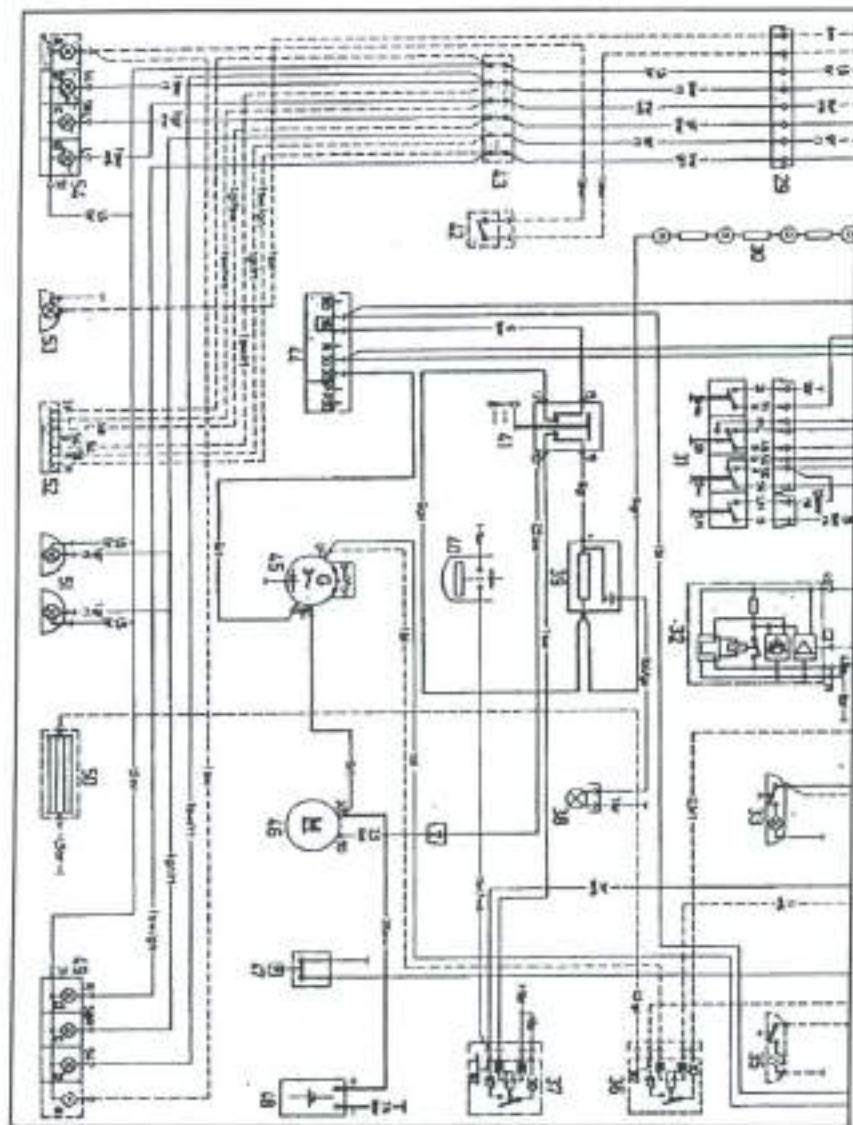

Legend - See Pages 188 to 189

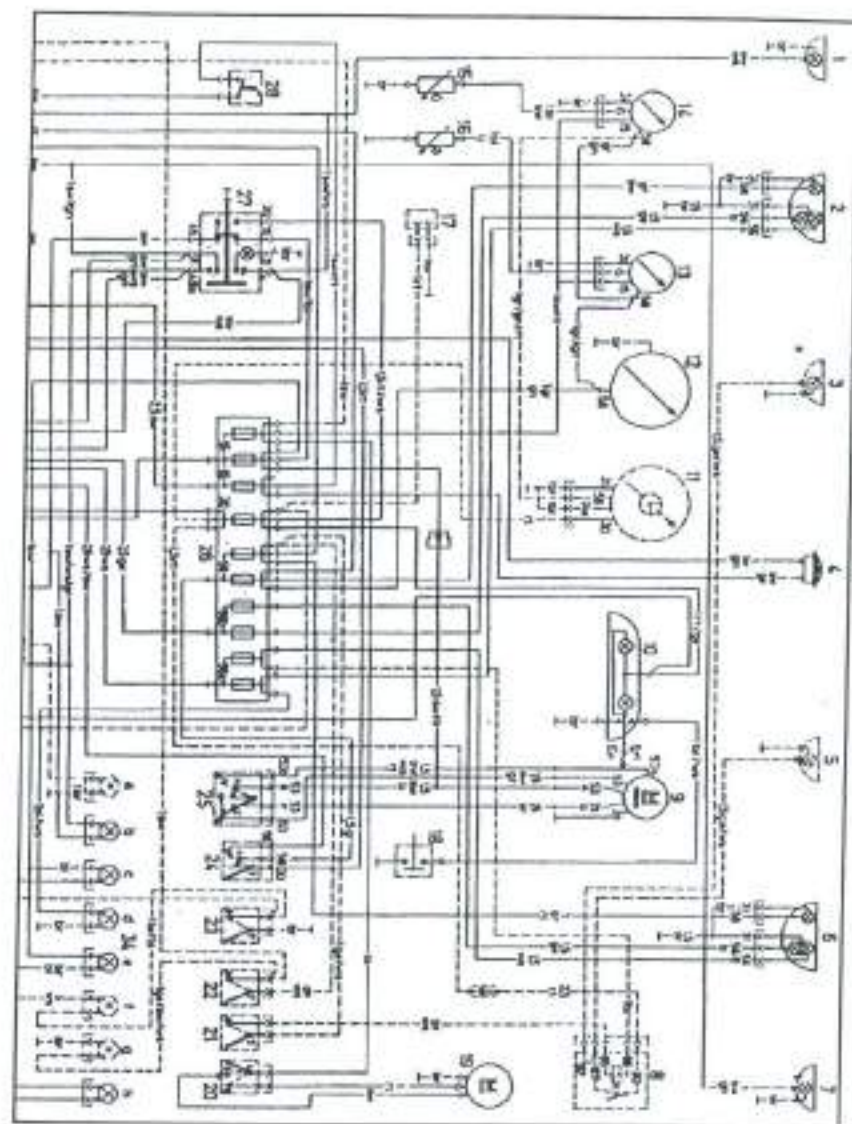

Legend - See Pages 188 to 189

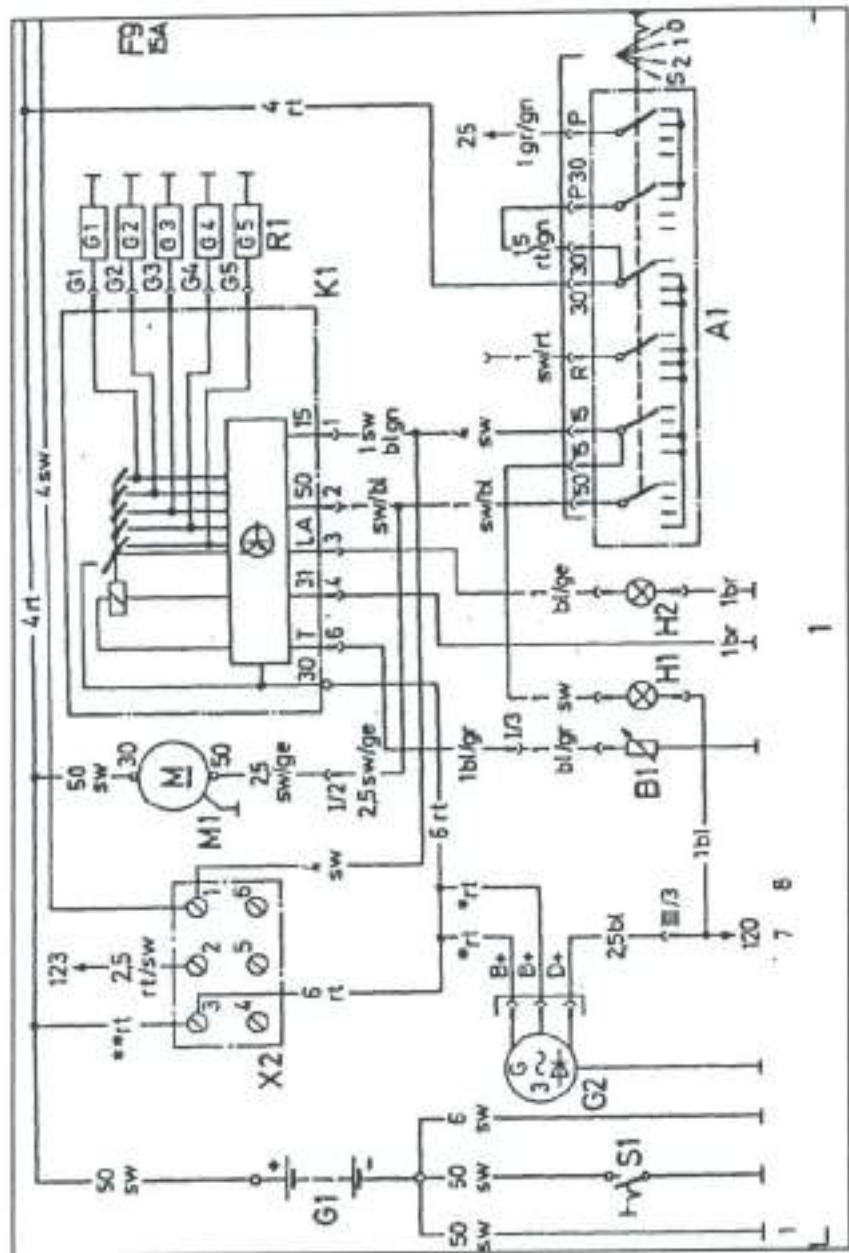

Legend - See Pages 188 to 189

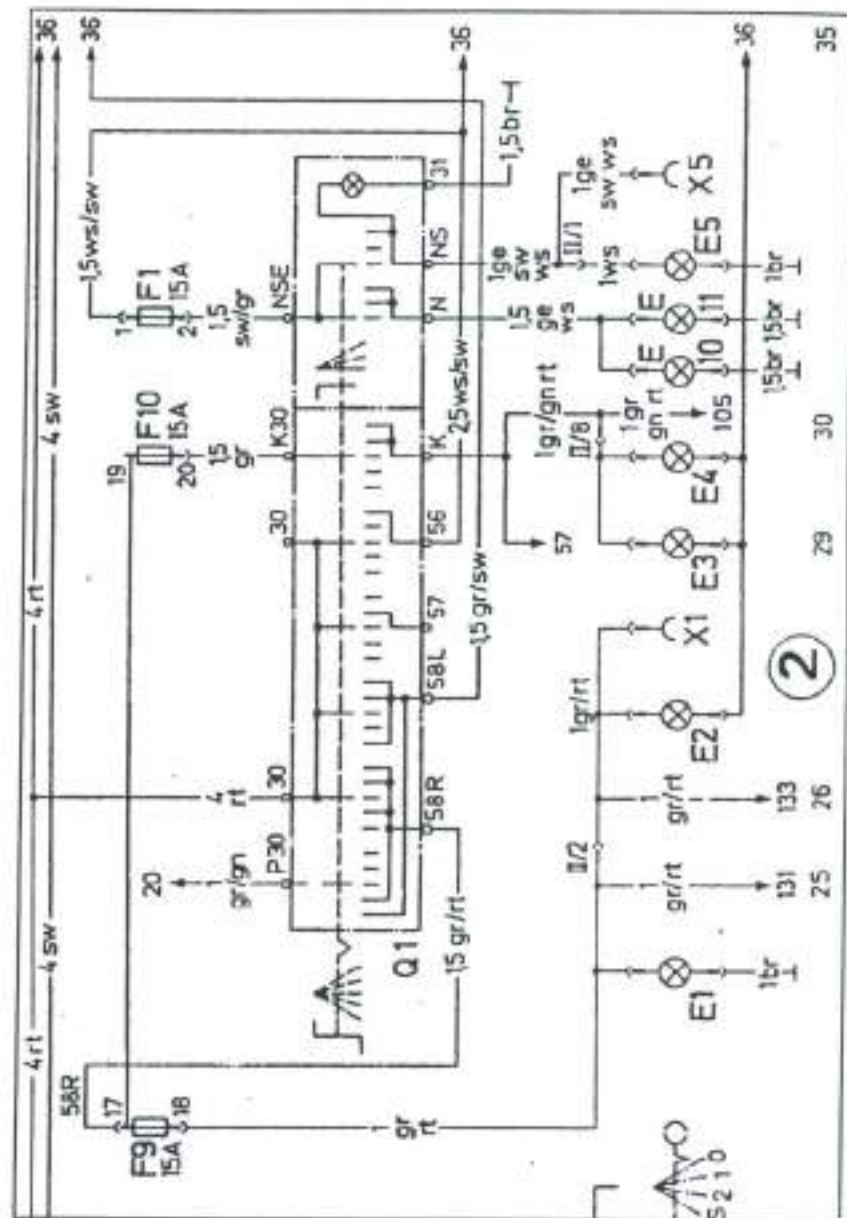

Legend - See Pages 188 to 189

