



YAMAHA







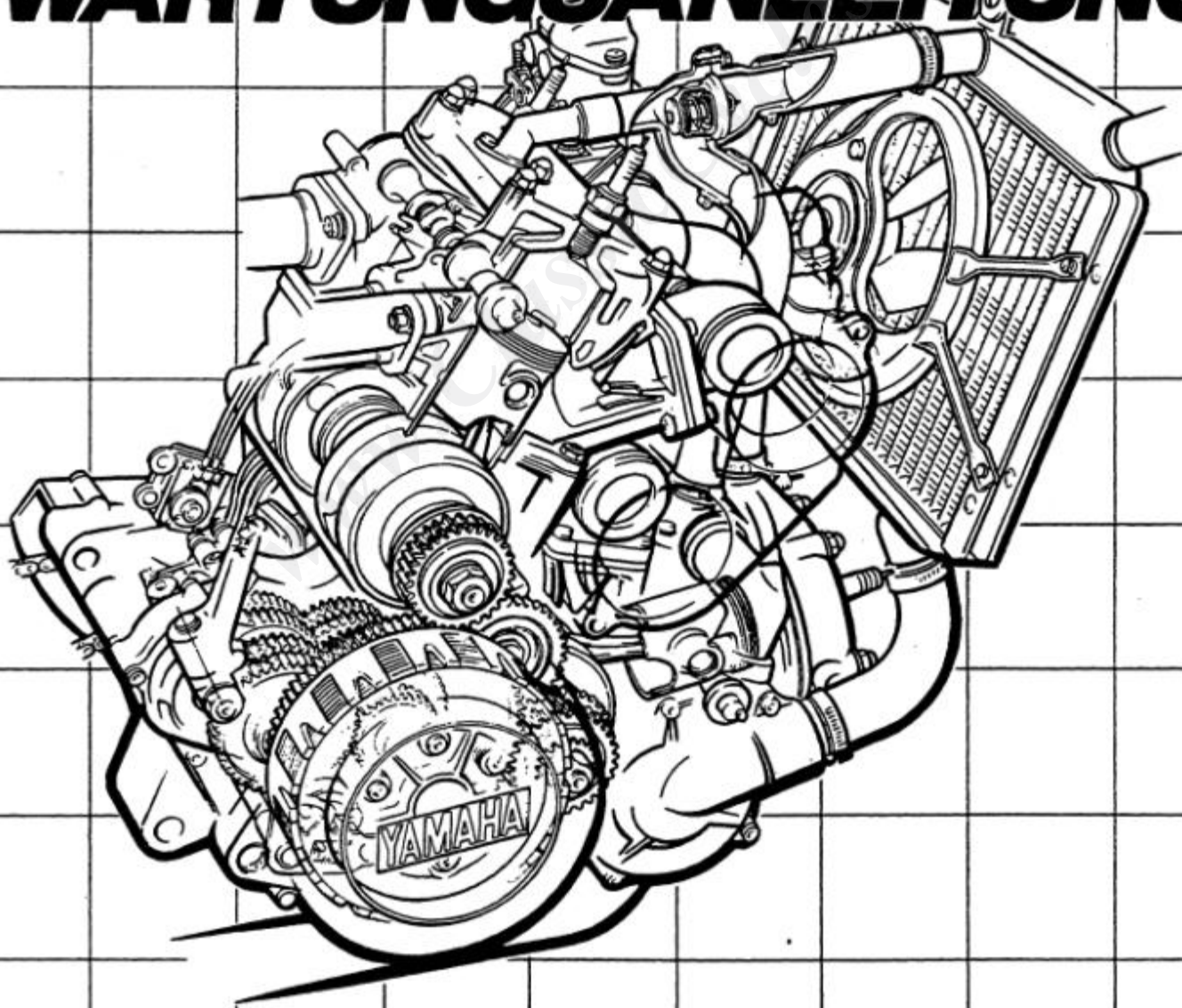

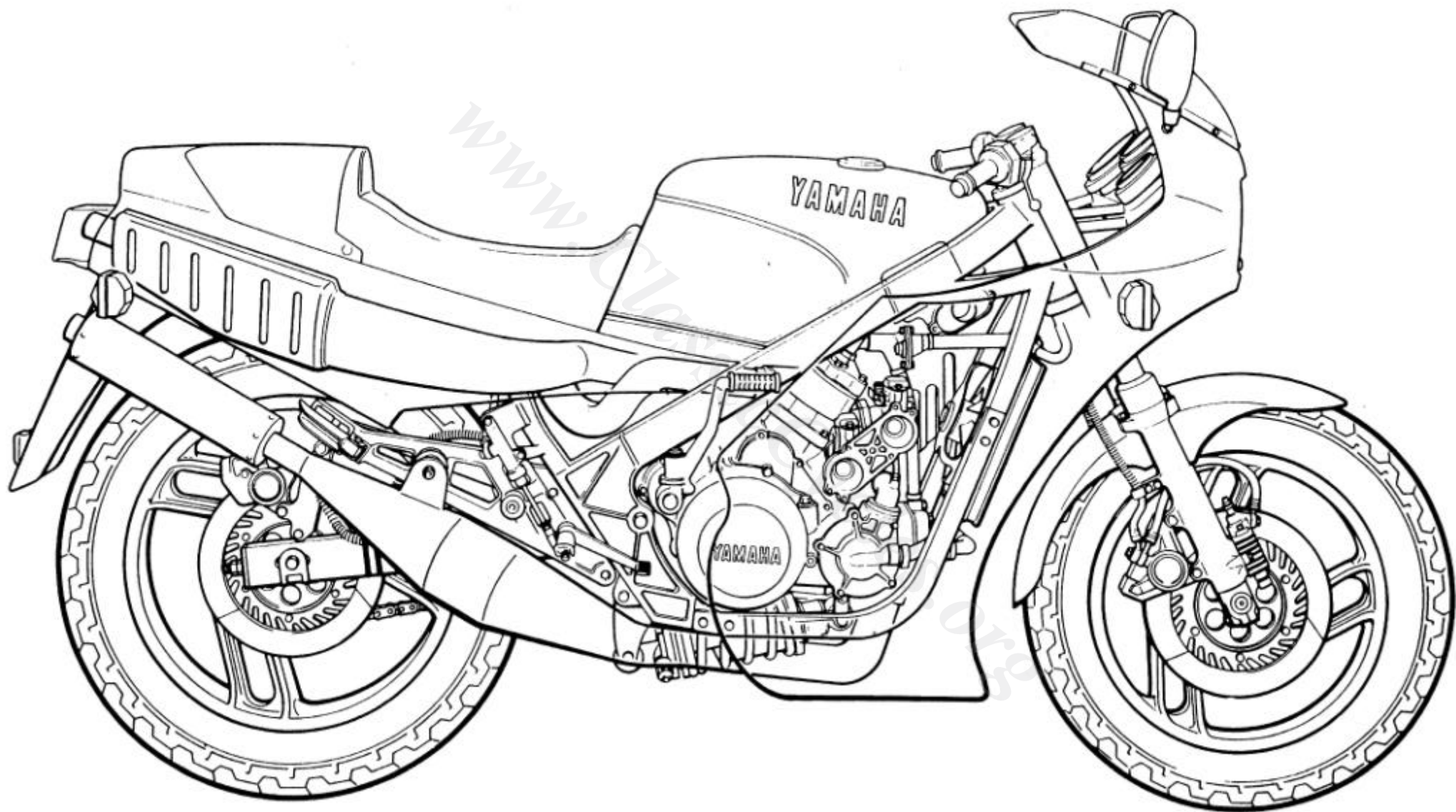

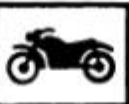









'84

RD500LC

**SERVICE MANUAL
MANUEL D'ATELIER
WARTUNGSANLEITUNG**





① GEN INFO 	② INSP ADJ 	
③ ENG 	④ COOL 	
⑤ CARB 	⑥ CHAS 	
⑦ ELEC 	⑧ APPX 	
⑨ 	⑩ 	
⑪ 	⑫ 	
⑬ 	⑭ 	
⑮ 	⑯ 	⑰ 
⑱ 	⑲ 	⑳ 
㉑ 		

ILLUSTRATED SYMBOLS (Refer to the illustration)

Illustrated symbols ① to ⑧ are designed as thumb tabs to indicate the chapter's number and content.

- ① General information
- ② Periodic inspection and adjustment
- ③ Engine
- ④ Cooling system
- ⑤ Carburetion
- ⑥ Chassis
- ⑦ Electrical
- ⑧ Appendices









Illustrated symbols ⑨ to ⑭ are used to identify the specifications appearing in the text.

- ⑨ Filling fluid
- ⑩ Lubricant
- ⑪ Tightening
- ⑫ Wear limit, clearance
- ⑬ Engine speed
- ⑭ Ω , V, A

Illustrated symbols ⑮ to ㉑ in the exploded diagram indicate grade of lubricant and location of lubrication point.

- ⑮ Apply engine oil
- ⑯ Apply gear oil
- ⑰ Apply molybdenum disulfide oil
- ⑱ Apply wheel bearing grease
- ⑲ Apply lightweight lithium-soap base grease
- ⑳ Apply molybdenum disulfide grease
- ㉑ Apply locking agent (LOCTITE®)

INDEX

GENERAL INFORMATION	 GEN INFO 1
PERIODIC INSPECTIONS AND ADJUSTMENTS	 INSP ADJ 2
ENGINE OVERHAUL	 ENG 3
COOLING SYSTEM	 COOL 4
CARBURETION	 CARB 5
CHASSIS	 CHAS 6
ELECTRICAL	 ELEC 7
APPENDICES	 APPX 8

CHAPTER 1. GENERAL INFORMATION

MOTORCYCLE IDENTIFICATION	1-1
FRAME SERIAL NUMBER	1-1
ENGINE SERIAL NUMBER.....	1-1
IMPORTANT INFORMATION	1-3
ALL REPLACEMENT PARTS	1-3
GASKETS, OIL SEALS, AND O-RINGS	1-3
LOCK WASHERS/PLATES AND COTTER PINS.....	1-3
BEARINGS AND OIL SEALS	1-3
CIRCLIPS.....	1-5
SPECIAL TOOLS	1-5
FOR TUNE-UP	1-5
FOR ENGINE SERVICE	1-7
FOR CHASSIS SERVICE.....	1-9
FOR ELECTRICAL COMPONENTS	1-11
OPTIONAL PARTS	1-11

www.ClassicCycles.org

**GENERAL
INFORMATION**

MOTORCYCLE IDENTIFICATION

FRAME SERIAL NUMBER

The frame serial number ① is stamped into the right side of the steering head pipe.

ENGINE SERIAL NUMBER

The engine serial number ① is stamped into the elevated part of the left rear section of the engine.

NOTE: _____
The first three digits of these numbers are for model identifications; the remaining digits are the unit production number.

Starting Serial Number:
RD500LC47X-000101

NOTE: _____
Designs and specifications are subject to change without notice.

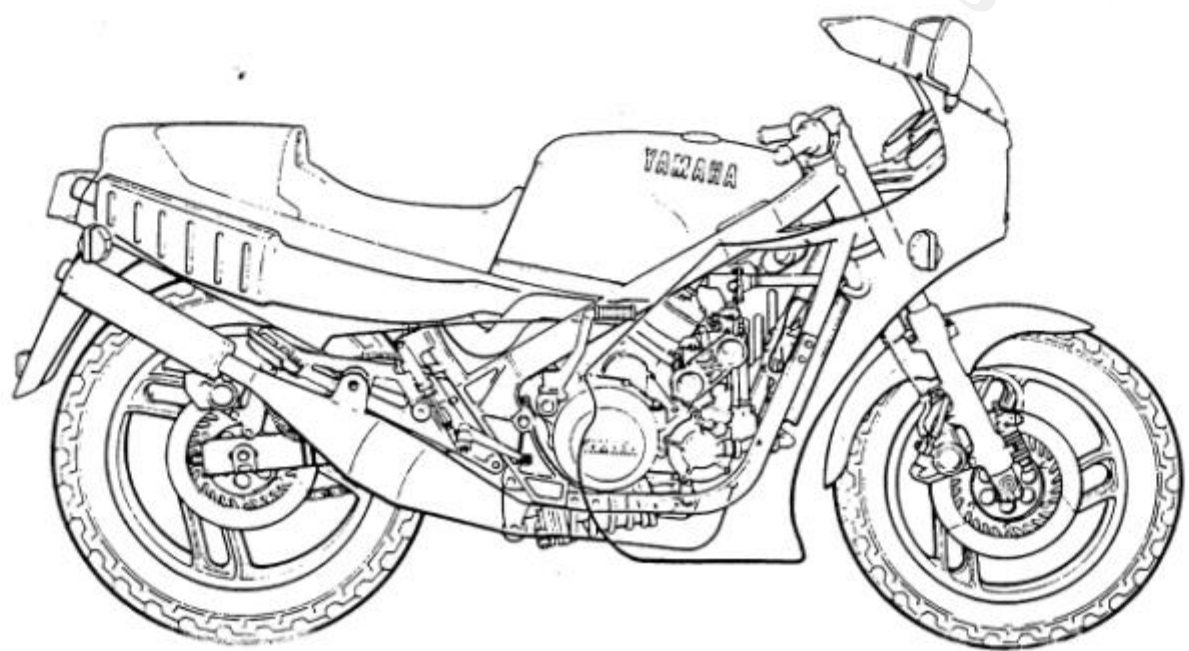
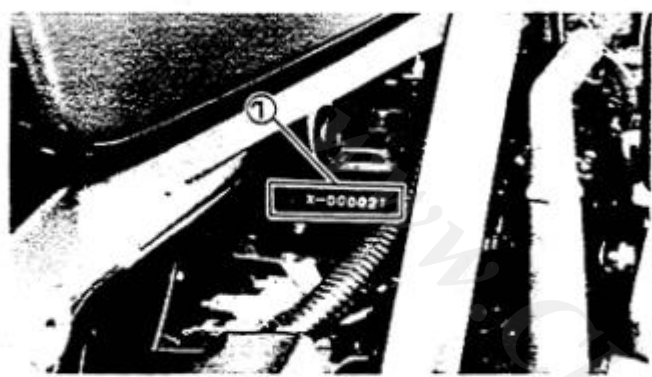



IMPORTANT INFORMATION

ALL REPLACEMENT PARTS

1. We recommend to use Yamaha genuine parts for all replacements. Use oil and/or grease recommended by Yamaha for assembly and adjustment.

GASKETS, OIL SEALS, AND O-RINGS

1. All gaskets, seals, and O-rings should be replaced when an engine is overhauled. All gasket surfaces, oil seal lips, and O-rings must be cleaned.
2. Properly oil all mating parts and bearings during reassembly. Apply grease to the oil seal lips.

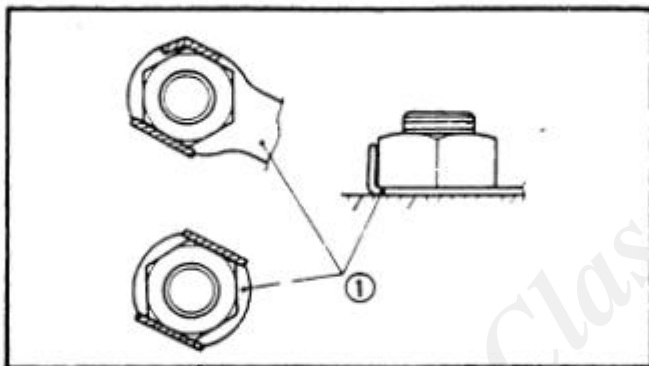

LOCK WASHERS/PLATES AND COTTER PINS

1. All lock washers/plates ① and cotter pins must be replaced when they are removed. Lock tab(s) should be bent along the bolt or nut flat(s) after the bolt or nut has been properly tightened.

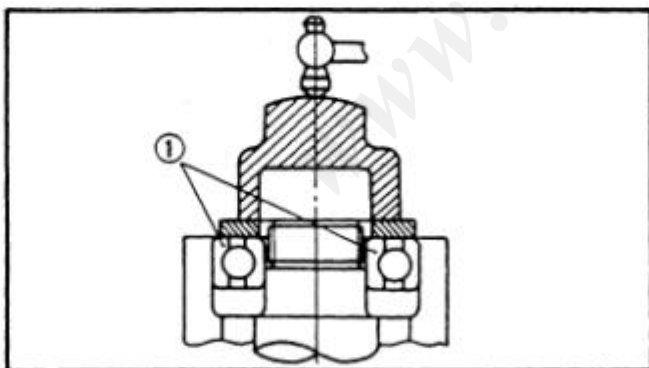

BEARINGS AND OIL SEALS

1. Install the bearing(s) ① and oil seal(s) ② with their manufacturer's marks or numbers facing outward. (In other words, the stamped letters must be on the side exposed to view.) When installing oil seal(s), apply a light coating of light-weight lithium base grease to the seal lip(s). Oil the bearings liberally when installing.

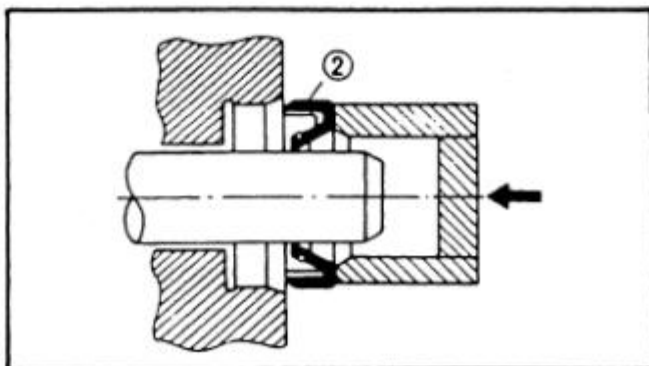

CAUTION:

Do not use compressed air to spin the bearings dry. This causes damage to the bearing surfaces.

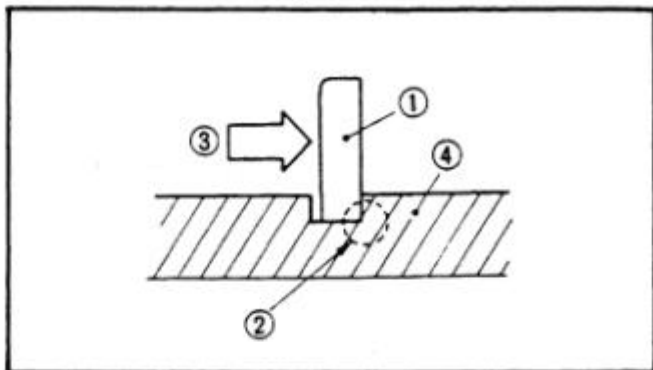
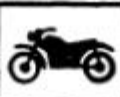

CIRCLIPS

1. All circlips should be inspected carefully before reassembly. Always replace piston pin clips after one use. Replace distorted circlips. When installing a circlip ①, make sure that the sharp-edged corner ② is positioned opposite to the thrust ③ it receives. See the sectional view.

④ Shaft

SPECIAL TOOLS

The proper special tools are necessary for complete and accurate tune-up and assembly. Using the correct special tool will help prevent damage caused by the use of improper tools or improvised techniques.

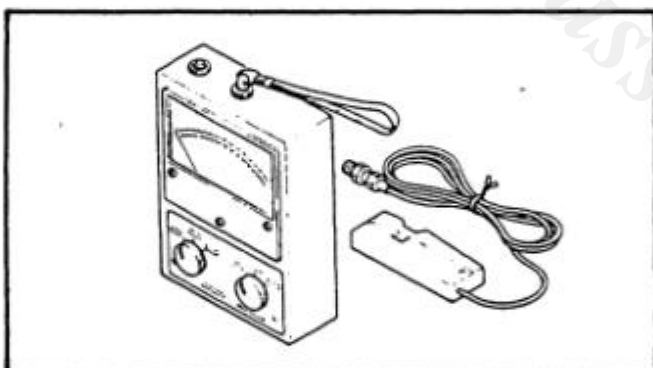

FOR TUNE UP

1. Inductive Tachometer
P/N 90890-03082

This tool is needed for detecting engine rpm.

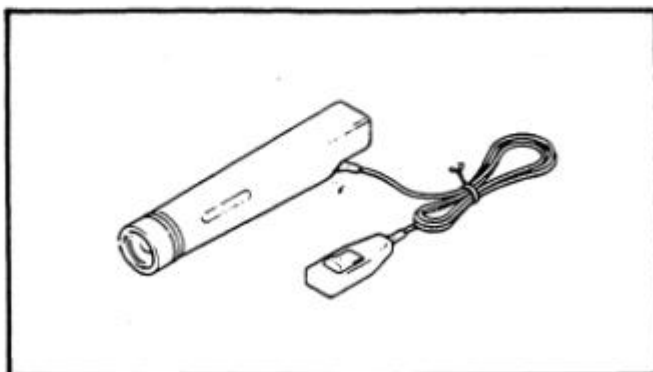

2. Inductive Timing Light
P/N 90890-03109

This tool is necessary for checking ignition timing.

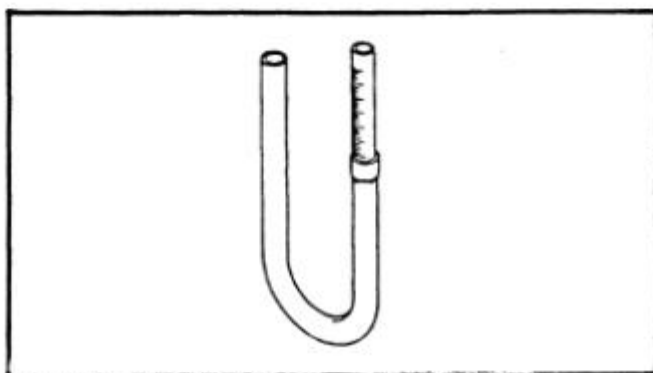

3. Fuel Level Gauge
P/N 90890-01312

This gauge is used to measure the fuel level in the float chamber.

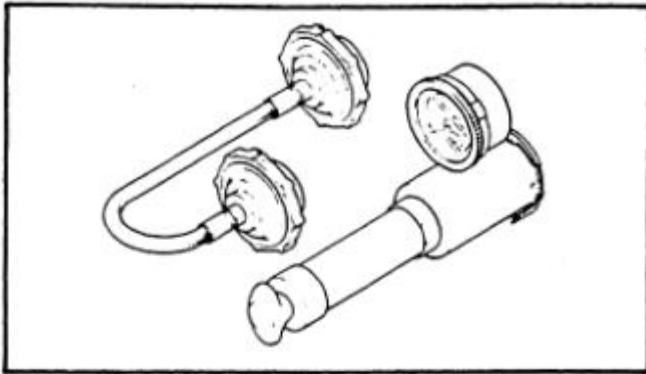

4. Cooling System Tester
P/N 90890-01325

This tester is needed for checking the cooling system.

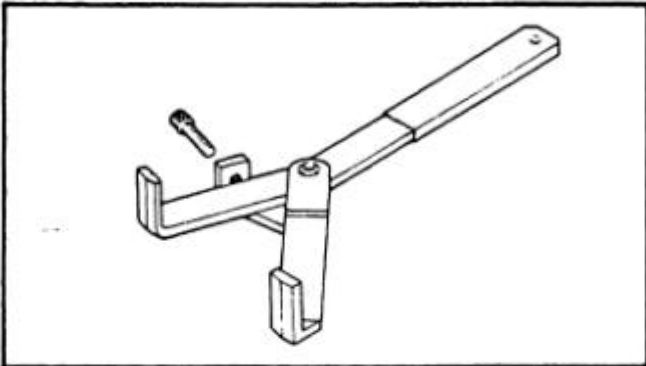

FOR ENGINE SERVICE

1. Universal Clutch Holder
P/N 90890-04086

This tool is used to hold the clutch when removing or installing the clutch boss locknut.

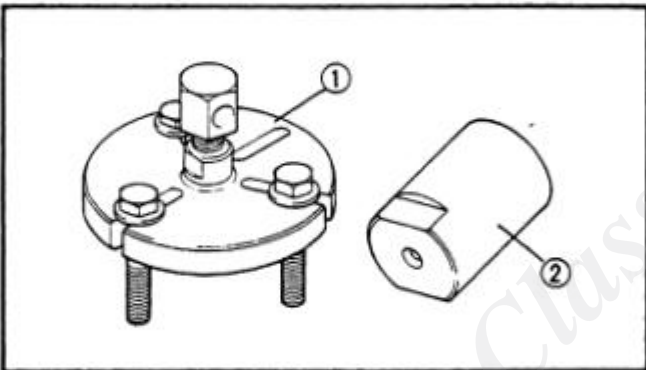

2. Flywheel Magneto Puller
P/N 90890-01362 – ①
Adapter
P/N 90890-04063 – ②

These tools are used to remove the flywheel.

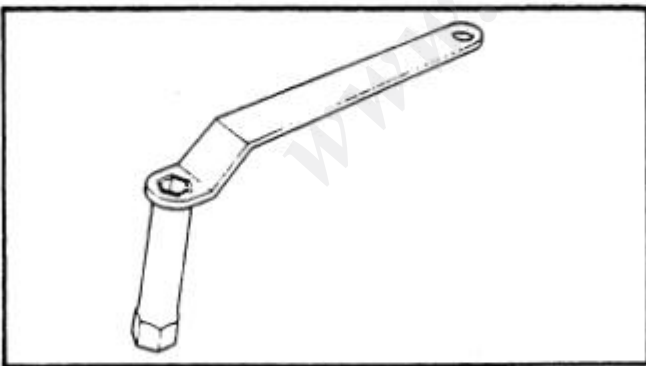

3. Clutch Adjusting Tool
P/N 90890-01204

This tool is used to adjust the clutch.

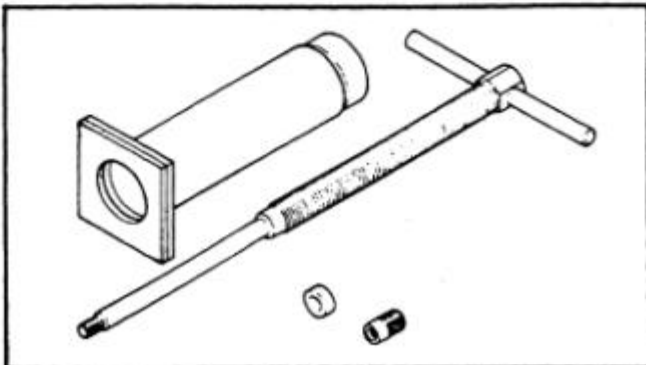

4. Piston Pin Puller
P/N 90890-01304

This tool is used to remove the piston pin.

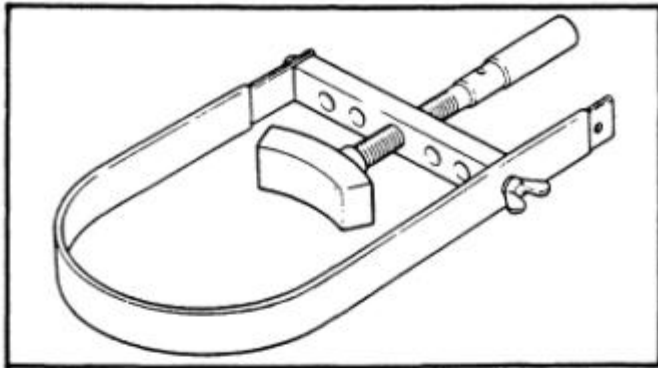

5. Universal Sheave Holder
P/N 90890-01701

This tool is used to hold the flywheel when removing or installing the flywheel nut.

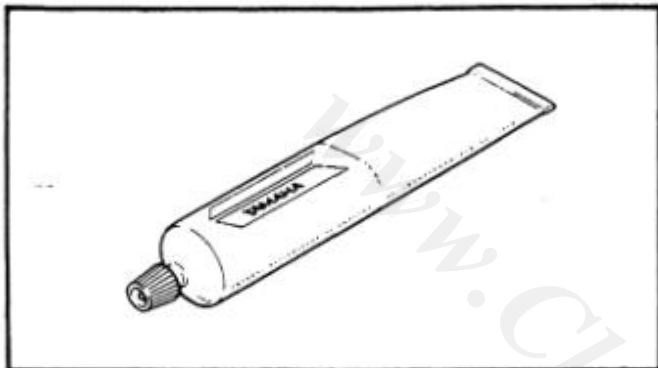

6. Yamaha Bond No. 1215
P/N 90890-85505

This sealant (bond) is used for crankcase mating surfaces, etc.

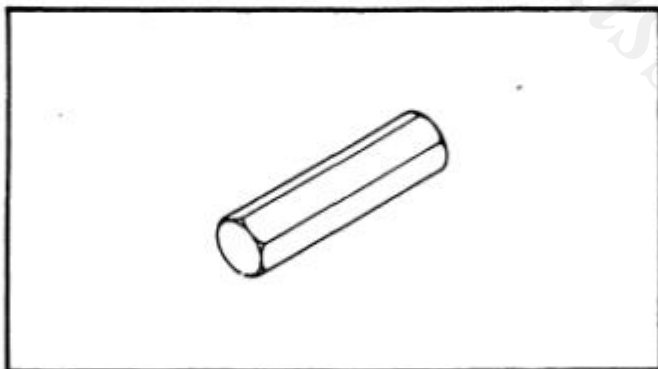

FOR CHASSIS SERVICE

1. Front Fork Cap Socket (17 mm)
P/N 90890-01104

This tool is needed when loosening and tightening the front fork cap bolt.

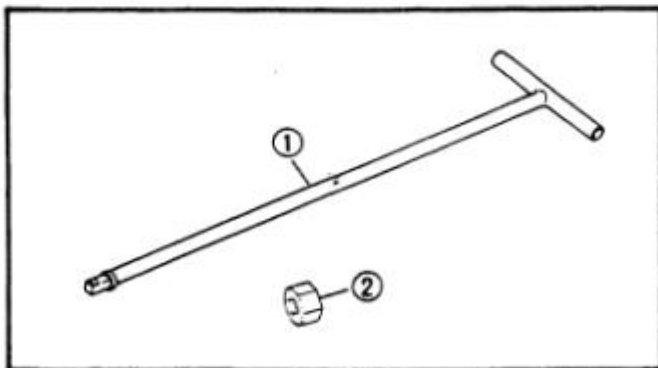

2. T-Handle
P/N 90890-01326 – ①
Damper Rod Holder (27 mm)
P/N 90890-01388 – ②

This tool is used to loosen and tighten the front fork cylinder holding bolt.

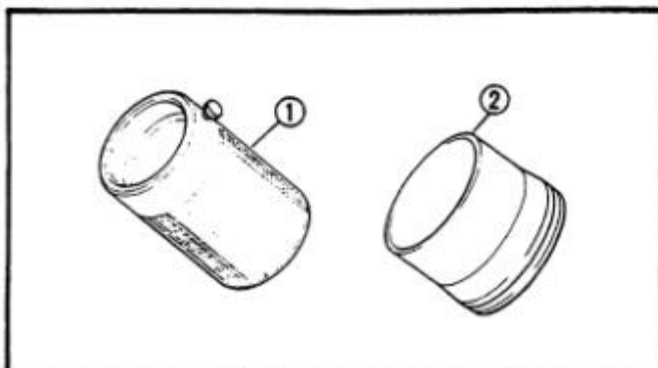

3. Front Fork Seal Driver (weight)
P/N 90890-01367 – ①
Adapter (41 mm)
P/N 90890-01381 – ②

These tools are used when installing the fork seal.

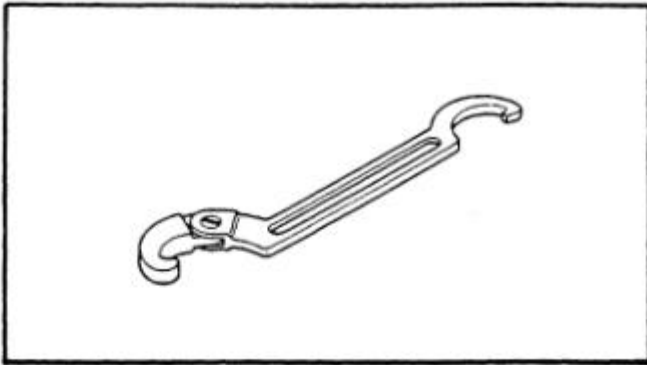

4. Ring Nut Wrench
P/N 90890-01268

This tool is used to loosen and tighten the steering ring nut.



FOR ELECTRICAL COMPONENTS

1. Electro Tester
P/N 90890-03021

This instrument is necessary for checking the ignition system components.

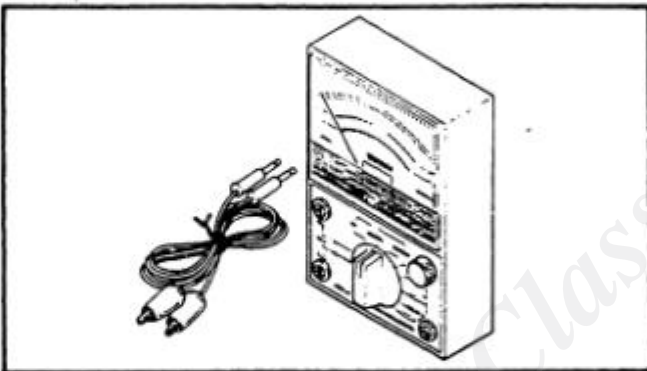

2. Pocket Tester
P/N 90890-03104

This instrument is invaluable for checking the electrical system.

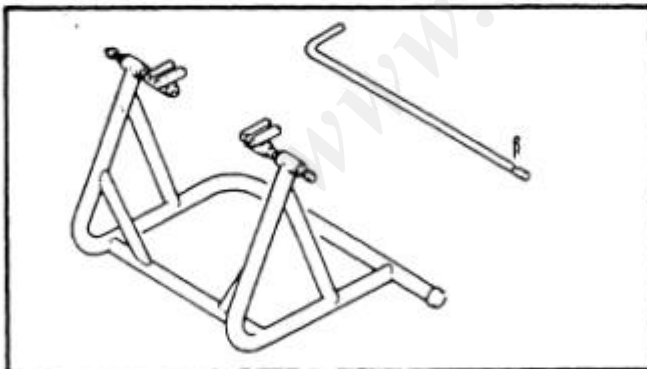

OPTIONAL PARTS

1. Racing Stand
P/N 51X-W0780-00

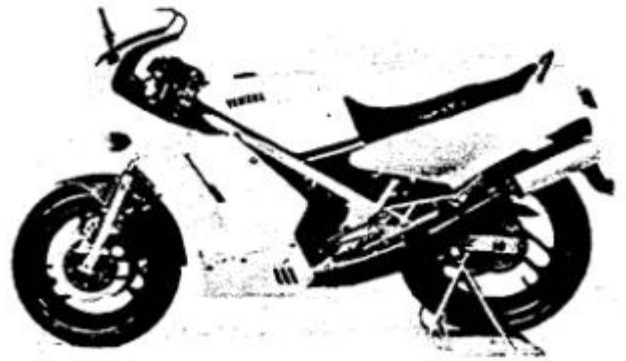
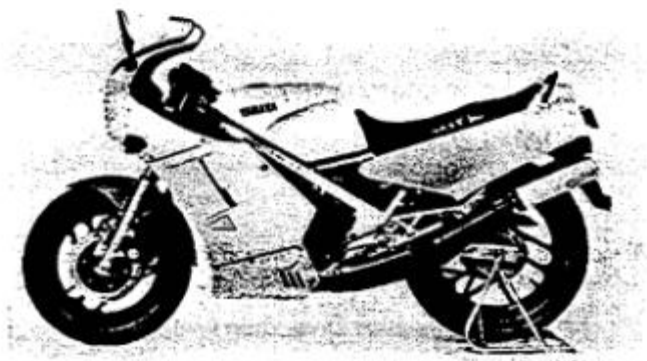

CHAPTER 2. PERIODIC INSPECTIONS AND ADJUSTMENTS

INTRODUCTION	2-1
PERIODIC MAINTENANCE/LUBRICATION INTERVALS	2-1
COWLING	2-7
LOWER COWLING	2-7
CENTER COWLINGS	2-9
REAR COWLING	2-11
UPPER COWLING	2-15
ENGINE	2-19
SPARK PLUG	2-19
FUEL LINE	2-21
INTAKE MANIFOLD	2-21
EXHAUST SYSTEM	2-23
THROTTLE CABLE ADJUSTMENT	2-25
CARBURETOR SYNCHRONIZATION	2-27
IDLE SPEED	2-27
YPVS (YAMAHA POWER VALVE SYSTEM)	2-29
ENGINE OIL	2-31
OIL PUMP	2-33
TRANSMISSION OIL	2-35
COOLANT	2-37
CLUTCH ADJUSTMENT	2-39
IGNITION TIMING CHECK	2-41
CHASSIS	2-43
DRIVE CHAIN	2-43
AIR FILTER	2-45
BRAKE FLUID INSPECTION	2-47
FRONT AND REAR BRAKE PAD INSPECTION	2-49
FRONT BRAKE	2-49
REAR BRAKE	2-49
CABLE INSPECTION AND LUBRICATION	2-51
BRAKE AND CHANGE PEDALS/BRAKE AND CLUTCH LEVERS	2-51
SIDESTAND	2-53
SWINGARM AND RELAY ARM	2-53
FRONT FORK OIL CHANGE	2-55

REAR SHOCK ABSORBER ADJUSTMENT 2-61
ANTI-DIVE ADJUSTMENT 2-65
STEERING HEAD ADJUSTMENT 2-69
WHEEL BEARINGS 2-75
TUBELESS TIRES AND ALUMINUM WHEELS 2-79

ELECTRICAL 2-83
BATTERY 2-83
HEADLIGHT 2-85
TAILLIGHT 2-89
FUSE 2-89

www.ClassicCycles.org



PERIODIC INSPECTIONS AND ADJUSTMENTS

INTRODUCTION

This chapter includes all information necessary to perform recommended inspections and adjustments. These preventive maintenance procedures, if followed, will ensure more reliable vehicle operation and a longer service life. The need for costly overhaul work will be greatly reduced. This information applies to vehicles already in service as well as new vehicles that are being prepared for sale. All service technicians should be familiar with this entire chapter.

PERIODIC MAINTENANCE/LUBRICATION INTERVALS

Unit: km (mi)

ITEM	REMARKS	BREAK-IN 1,000 (600)	EVERY	
			6,000 (4,000) or 6 months	12,000 (8,000) or 12 months
Spark plug(s)	Check condition. Clean or replace if necessary.	○	○	○
Air filter	Clean. Replace if necessary.		○	○
Carburetor*	Check idle speed/synchronization/starter operation. Adjust if necessary.	○	○	○
Fuel line*	Check fuel hose and vacuum pipe for cracks or damage. Replace if necessary.		○	○
Transmission oil*	Check oil level/oil leakage. Correct if necessary. Replace every 24,000 (16,000) or 24 months. Warm engine before draining.	REPLACE	○	○
Autolube pump*	Check operation. Correct if necessary. Air bleeding.	○	○	○
YPVS system*	Check operation. Correct if necessary.	○	○	○
Brake*	Check operation/fluid leakage/See NOTE. Correct if necessary.		○	○
Clutch	Check operation. Adjust if necessary.		○	○
Rear arm pivot*	Check rear arm assembly for looseness. Correct if necessary. Lubricate.***	○	○	○
Rear suspension link pivots*	Check operation. Lubricate.***	○	○	○
Wheels*	Check balance/damage/runout. Repair if necessary.		○	○
Wheel bearings*	Check bearing assembly for looseness/damage. Replace if damaged.		○	○
Steering bearing*	Check bearing assembly for looseness. Correct if necessary. Moderately repack every 24,000 (16,000) or 24 months.**	○		○

PERIODIC MAINTENANCE/LUBRICATION INTERVALS



ITEM	REMARKS	BREAK-IN 1,000 (600)	EVERY	
			6,000 (4,000) or 6 months	12,000 (8,000) or 12 months
Front forks*	Check operation/oil leakage. Repair if necessary.		○	○
Rear shock absorber*	Check operation/oil leakage. Repair if necessary.		○	○
Cooling system	Check coolant leakage. Repair if necessary. Replace coolant every 24,000 (16,000) or 24 months.		○	○
Drive chain	Check chain slack/alignment. Adjust if necessary. Clean and lube.	EVERY 500 (300)		
Fittings/Fasteners*	Check all chassis fittings and fasteners. Correct if necessary.	○	○	○
Sidestand*	Check operation. Repair if necessary.	○	○	○
Battery*	Check specific gravity. Check breather pipe for proper operation. Correct if necessary.		○	○

*: It is recommended that these item be serviced by a Yamaha dealer.

** : Medium weight wheel bearing grease.

***: Lithium soap base grease.

NOTE:

Brake fluid replacement:

1. When disassembling the master cylinder or caliper cylinder, replace the brake fluid. Normally check the brake fluid level and add the fluid as required.
2. On the inner parts of the master cylinder and caliper cylinder, replace the oil seals every two years.
3. Replace the brake hoses every four years, or if cracked or damaged.

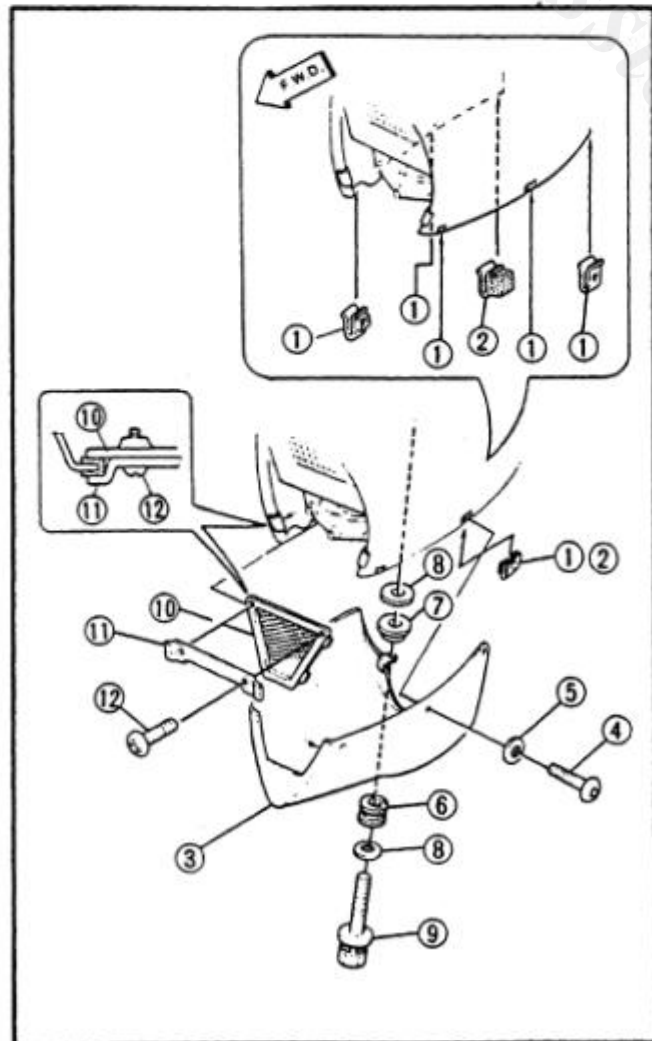
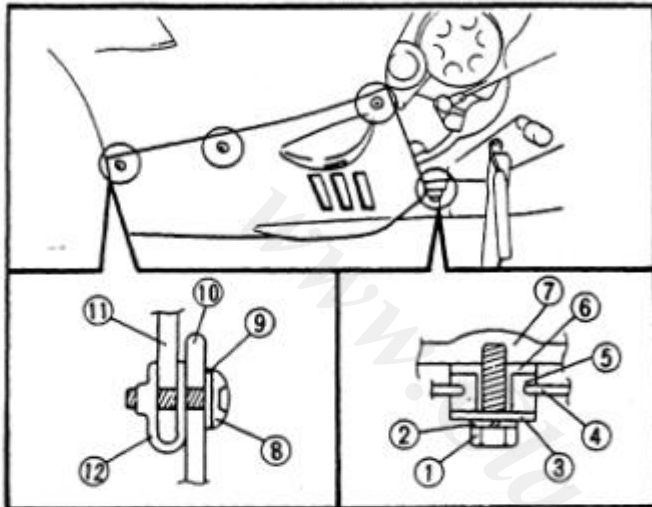
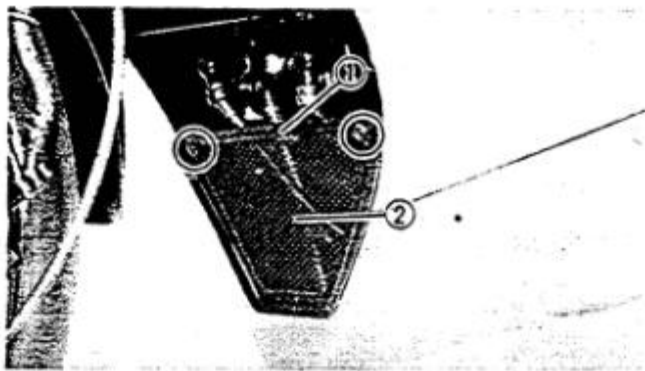

COWLING

LOWER COWLING

Removal

1. Remove:
 - Screws
 - Engine grille holder stay ①
 - Engine grille ②

2. Remove:
 - Mounting bolts
 - Lower cowling ④, ⑩

NOTE:

Do not lose the plastic washers ⑨.

- | | |
|-----------------|----------------------------|
| ① Hexagon bolt | ⑦ Frame stay |
| ② Spring washer | ⑧ Hexagon socket head bolt |
| ③ Plain washer | ⑨ Plastic washer |
| ④ Lower cowling | ⑩ Lower cowling |
| ⑤ Grommet | ⑪ Center cowling |
| ⑥ Collar | ⑫ Spring nut |

Installation

1. Install:
 - Lower cowling
 - Mounting bolts
2. Tighten:
 - Bolts
 - Tighten the bolts evenly.
3. Install:
 - Engine grille

No.	Part name	Q'ty	Remarks mm (in)
①	Spring nut	5	d = 5 (0.20)
②	Spring nut (With damper)	1	d = 5 (0.20)
③	Lower cowling	1	
④	Hexagon socket head bolt	6	d = 5 (0.20), ℓ = 12 (0.47)
⑤	Plastic washer	6	d = 6 (0.24)
⑥	Grommet	2	Rubber
⑦	Collar	2	d = 6 (0.24)
⑧	Plain washer	4	d = 6 (0.24)
⑨	Hexagon bolt with spring washer and plain washer	2	d = 6 (0.24), ℓ = 20 (0.78)
⑩	Engine grille	1	
⑪	Holder stay	1	
⑫	Screw	2	d = 5 (0.20), ℓ = 12 (0.47)



CENTER COWLINGS

Removal

- Remove:
 - Engine grille
 - Lower cowling
 - Mounting bolts
 - Center cowlings

NOTE:

Do not lose the spring nuts ⑫ and washers.

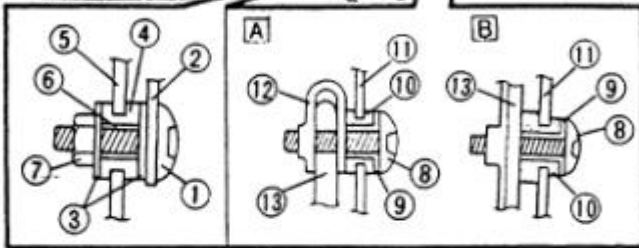
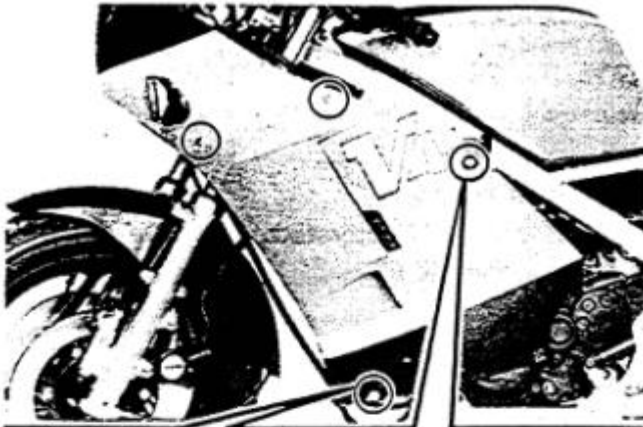

- ① Hexagon socket head bolt
- ② Center cowling
- ③ Plain washer
- ④ Grommet
- ⑤ Frame stay
- ⑥ Collar
- ⑦ Hexagon nut
- ⑧ Hexagon socket head bolt
- ⑨ Collar
- ⑩ Grommet
- ⑪ Center cowling
- ⑫ Spring nut
- ⑬ Air duct
- A RIGHT SIDE
- B LEFT SIDE

Installation

- Install:
 - Center cowlings
 - Mounting bolts
 - Lower cowling
 - Engine grille

Tighten bolts evenly.

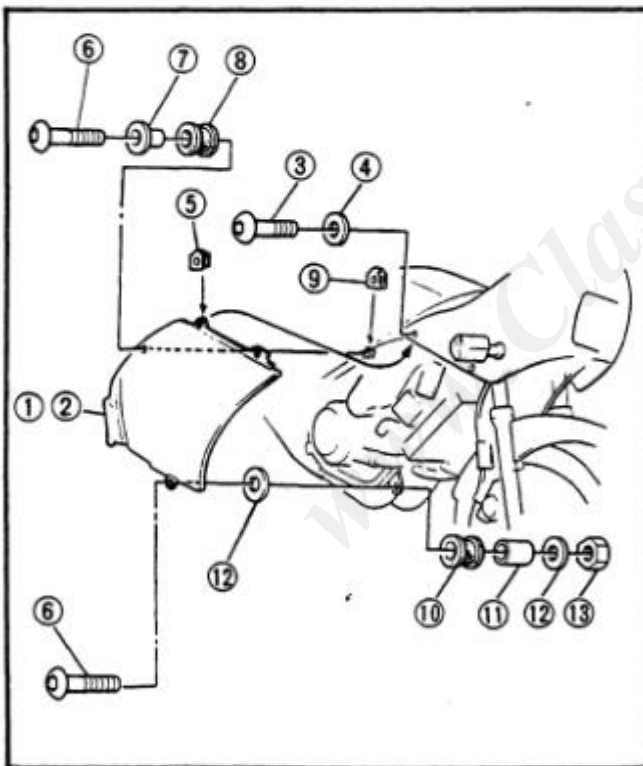

No.	Part name	Q'ty	Remarks mm (in)
①	Center cowling (Right)	1	
②	Center cowling (Left)	1	
③	Hexagon socket head bolt	4	d = 5 (0.20), ℓ = 12 (0.47)
④	Plain washer	4	d = 5 (0.20)
⑤	Spring nut	4	d = 5 (0.20)
⑥	Hexagon socket head bolt	4	d = 6 (0.24), ℓ = 22 (0.86)
⑦	Collar	2	d = 6 (0.24)
⑧	Grommet (Left and right)	2	Rubber
⑨	Spring nut (Right only)	1	d = 6 (0.24)
⑩	Grommet	2	Rubber
⑪	Collar	2	d = 6 (0.24)
⑫	Plain washer	4	d = 6 (0.24)
⑬	Hexagon nut	2	d = 6 (0.24)



REAR COWLING

Removal

1. Remove:
 - Seat

2. Remove:
 - Tool kit ①

3. Remove:
 - Mounting bolts (Grab bar ①)
 - Mounting screws (Rear cowling ②)

4. Unhook the rear cowling by simply pulling its front towards you.

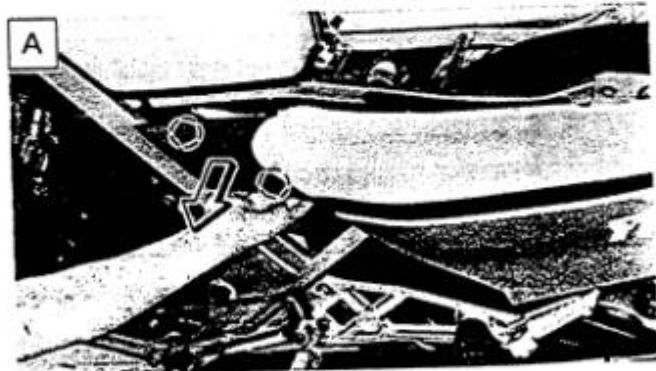
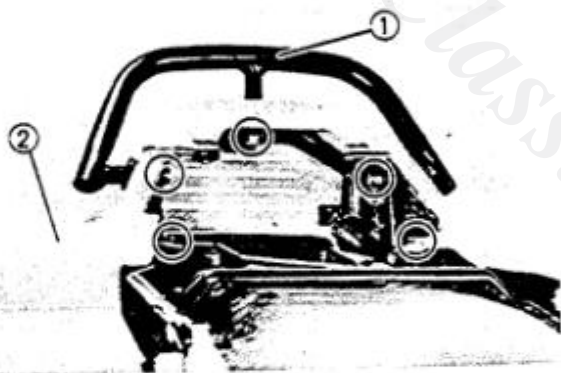
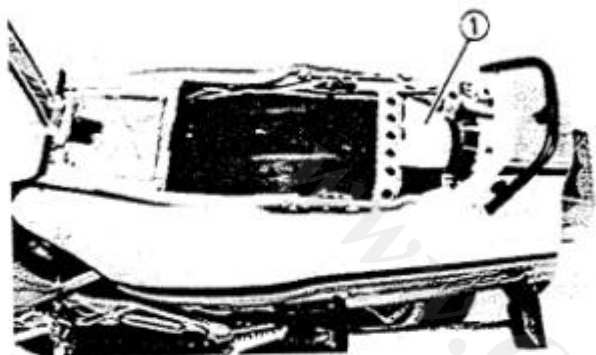
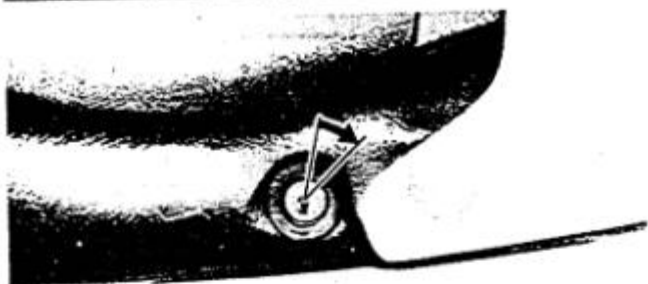

A LEFT

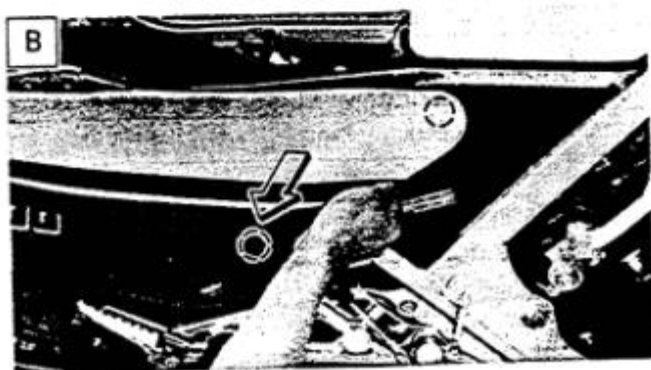

B RIGHT

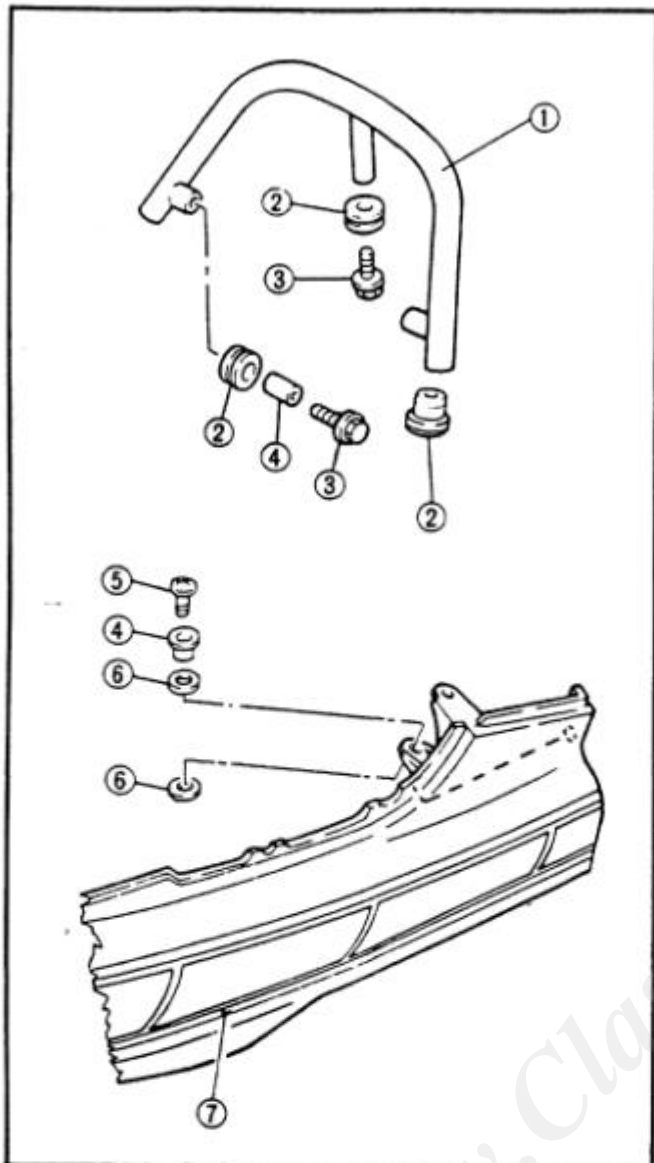

NOTE:

- Do not lose the collars ④ and gaskets ⑥.
- Inspect the cowling gaskets ⑥ and replace them if damaged.

- ① Grab bar
- ② Grommet
- ③ Bolt
- ④ Collar
- ⑤ Screw
- ⑥ Gasket
- ⑦ Rear cowling

5. Remove:

- Rear cowling assembly ①
- Grab bar
Remove together by pulling the grab bar rearwards.

Installation

1. Install:
 - Rear cowling
Reverse the removal procedure.
2. Tighten:
 - Mounting bolts (Grab bar)



Grab Bar:
15 Nm (1.5 m·kg, 11 ft·lb)



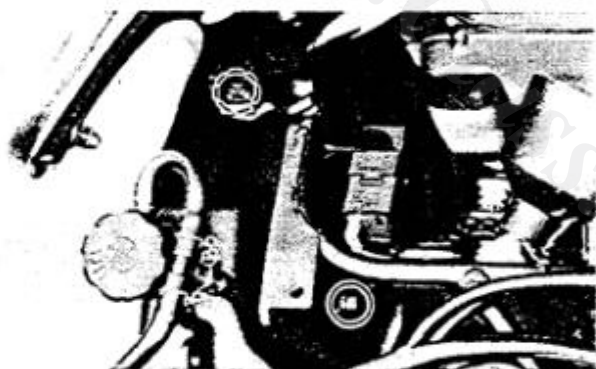
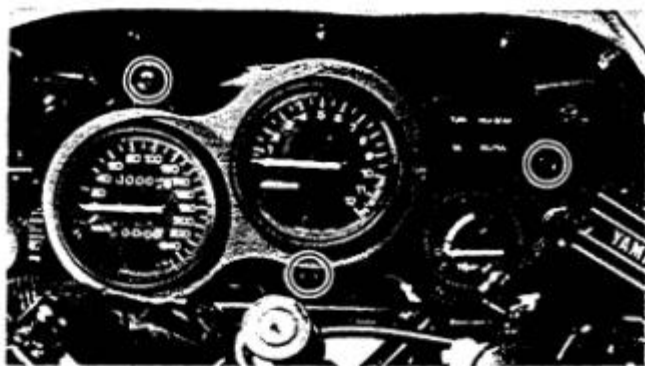

UPPER COWLING

Removal

1. Remove:
 - Lower cowling
 - Center cowlings
 - Meter assembly
2. Disconnect:
 - Flasher leads
 - Headlight connectors
 - Speedometer cable
3. Remove:
 - Flasher lights
 - Cap retainer ①
 - Rear view mirror (Left) ②
 - Mounting bolt (Oil tank)
4. Pull up the oil tank.

5. Remove:
 - Mounting bolts

6. Remove:
 - Cap retainer ①
 - Rear view mirror (Right) ②
 - Meter cover ③
 - Mounting bolt (Reservoir tank)
7. Pull up the reservoir tank.

8. Remove:
 - Mounting bolts



9. Remove:
 - Mounting bolt

10. Remove:
 - Upper cowling

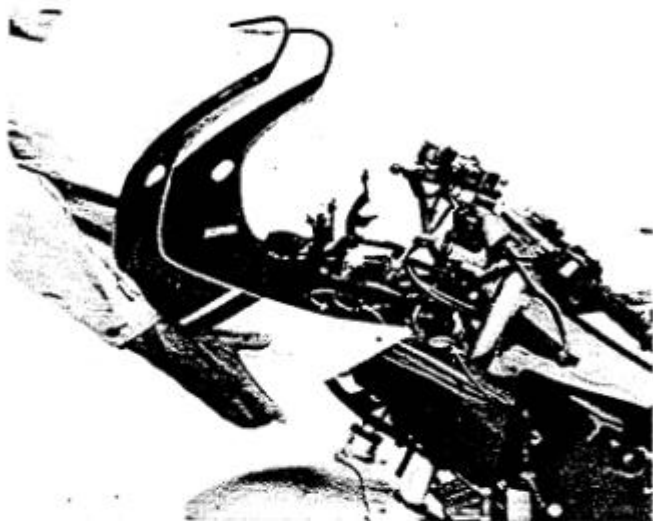

Installation

1. Install:
 - Upper cowling
 - Mounting bolts
2. Tighten:
 - Mounting bolts

Tighten the mounting bolts evenly.
3. Install:
 - Flasher lights
 - Rear view mirrors
 - Meter assembly
4. Connect:
 - Meter light
 - Headlight
 - Flasher lights
 - Speedometer cable
5. Install:
 - Meter cover
 - Center cowlings
 - Lower cowling

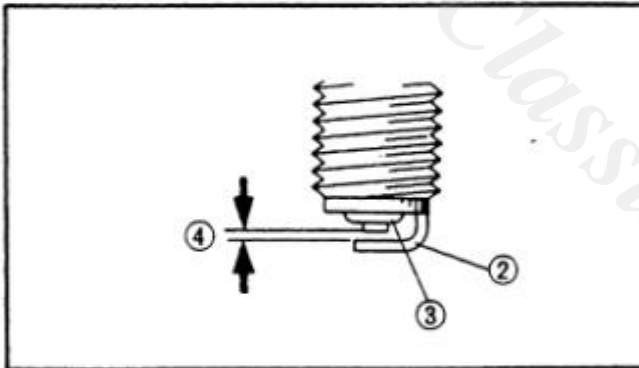
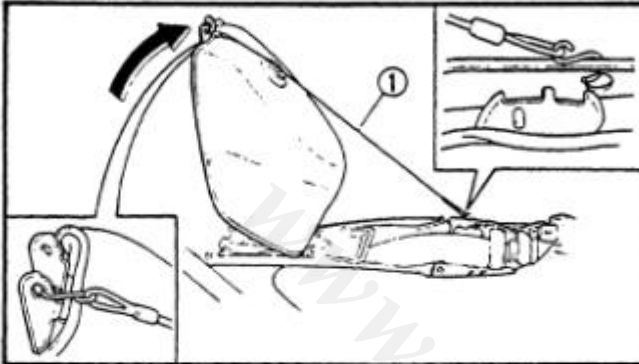

ENGINE

SPARK PLUG

1. Remove:
 - Seat
 - Bolt (Fuel tank)

2. Pull up the fuel tank. Use the fuel tank holding wire ① as shown.

NOTE: _____
The fuel tank holding wire ① can be found in the owners tool kit.

3. Remove:
 - Spark plugs
4. Inspect:
 - Electrode ②
Wear/Damage → Replace.
 - Insulator ③
Abnormal color → Replace.
5. Measure:
 - Plug gap ④
Use a Wire Gauge or Feeler Gauge.
Out of specification → Regap.

 **Spark Plug Gap:**
0.6 ~ 0.7 mm (0.024 ~ 0.028 in)

6. Clean the plug with a spark plug cleaner if necessary.

Standard Spark Plug:
BR9HS (NGK)
W27FSR (NIPPONDENSO)

7. Tighten:
 - Spark plug(s)
Before installing a spark plug, clean the gasket and plug surfaces.

 **Spark Plug:**
20 Nm (2.0 m·kg, 14 ft·lb)

NOTE: _____
Finger-tighten the spark plug(s) before torquing to specification.



8. Install:
 - Fuel tank
 - Seat



Fuel Tank:
10 Nm (1.0 m·kg, 7.2 ft·lb)

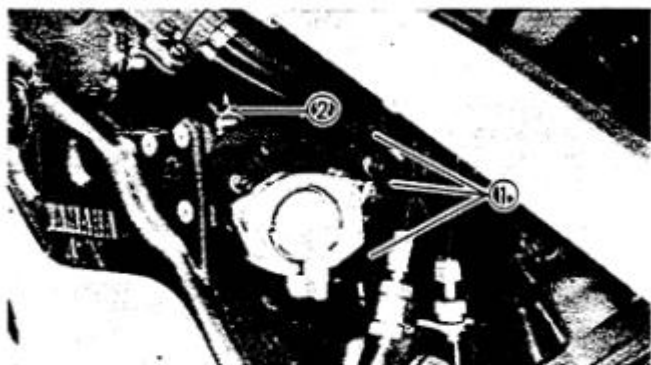

FUEL LINE

1. Inspect:
 - Fuel hoses ①
 - Vacuum hose ②
 Cracks/Damage → Replace.

INTAKE MANIFOLD

1. Tighten:
 - Carburetor clamps
 - Carburetor joint bolts
2. Inspect:
 - Carburetor joint ①
 - Gaskets ②
 - O-rings
 Cracks/Damage → Replace.

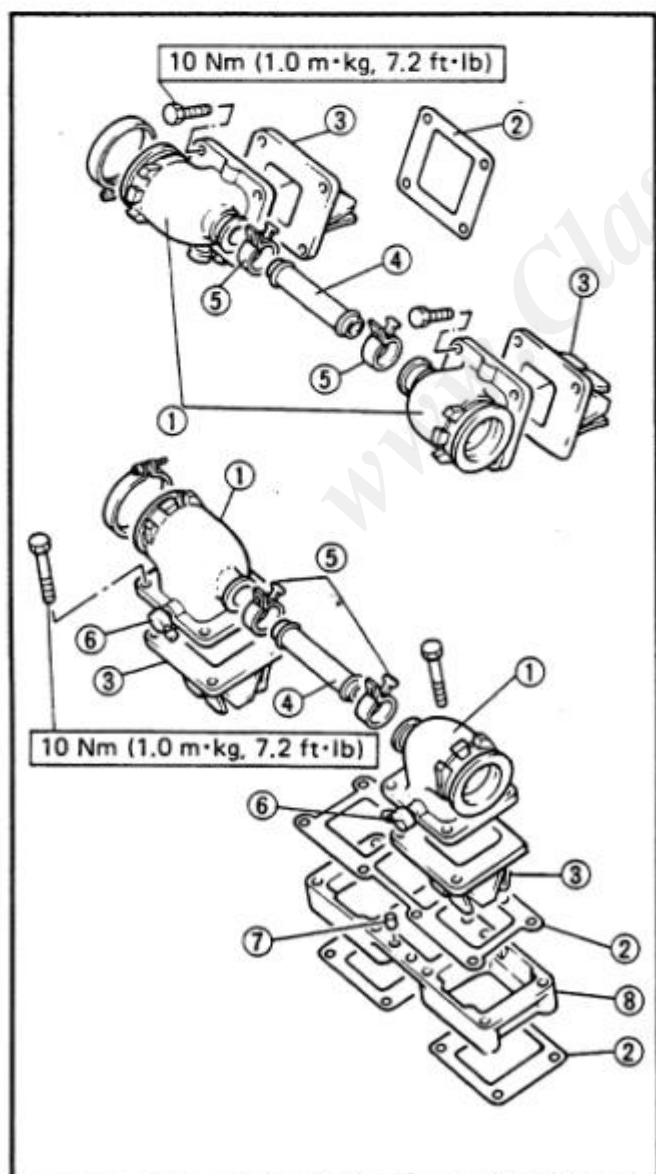

- ① Carburetor joint
- ② Gasket
- ③ Reed valve
- ④ Balancer pipe
- ⑤ Band
- ⑥ Delivery hose nozzle
- ⑦ Dowel pin
- ⑧ Housing

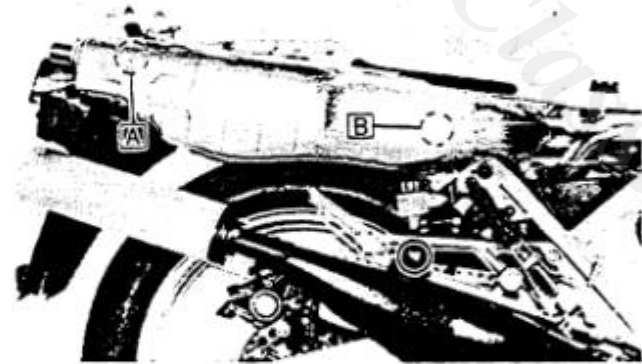
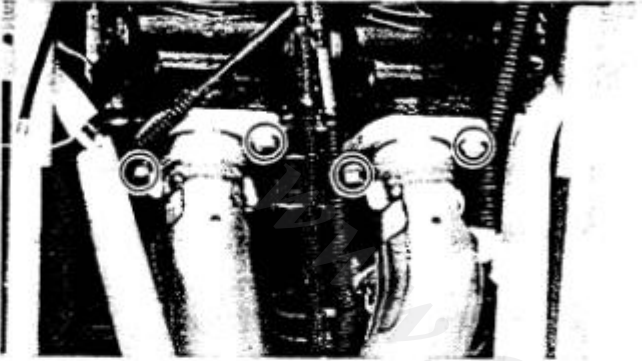
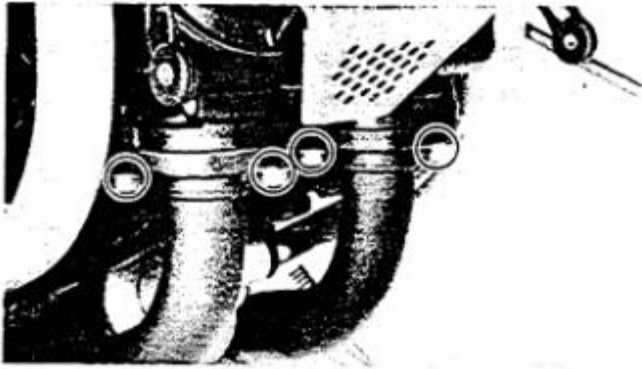

EXHAUST SYSTEM

1. Inspect:
 - Exhaust pipe gasket(s) ①
 - Silencer gasket(s) ②
 - Damage → Replace.
 - Exhaust gas leakage → Repair.
 - Silencer
 - Contamination → Clean.
 - Damage → Replace.

2. Tighten:
 - Exhaust pipe
 - Muffler
 - Silencer

	Exhaust Pipe (Studbolt):
	13 Nm (1.3 m·kg, 9.4 ft·lb)
	Muffler – Cylinder:
	22 Nm (2.2 m·kg, 16 ft·lb)
	Muffler – Muffler Bracket:
25 Nm (2.5 m·kg, 18 ft·lb)	
Silencer (Nut/Screw):	
6 Nm (0.6 m·kg, 4.3 ft·lb)	

- A** Shorter bolt
- B** Longer bolt

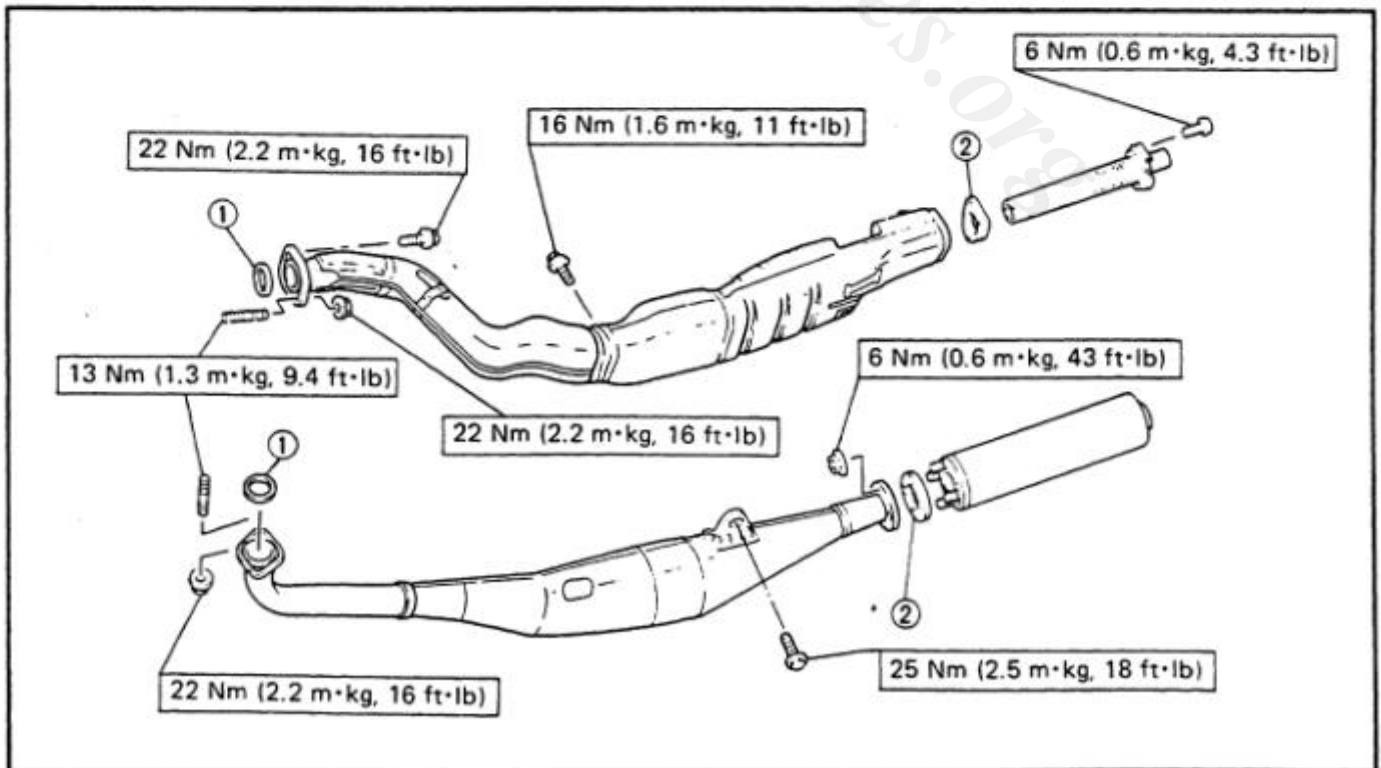



THROTTLE CABLE ADJUSTMENT

Carburetors must be adjusted to open and close simultaneously.

1. Check:
 - Carburetor marks (at full throttle)
Not aligned → Adjust the throttle cable.

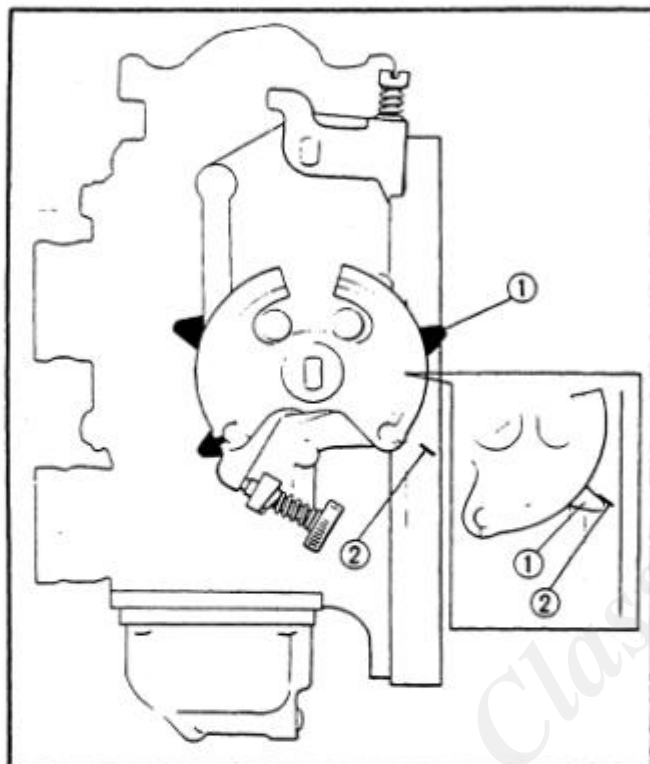

Throttle cable adjustment steps (1):

- Turn the throttle grip until it stops completely so that all throttle valves are fully opened.
- While keeping the grip at this point (full throttle), check the carburetor pulley mark ① on each pair of carburetors. The pulley mark should align, as shown, with the full open mark ② on the carburetor body.
- If not, adjust the OPEN-SIDE throttle cable ③ by turning the adjuster ④ in or out.
- Next, check the CLOSE-SIDE throttle cables ⑤. They must have a slight free play. If not, adjust the close-side throttle cable by turning the adjuster ⑥ in or out.

7. Locknut

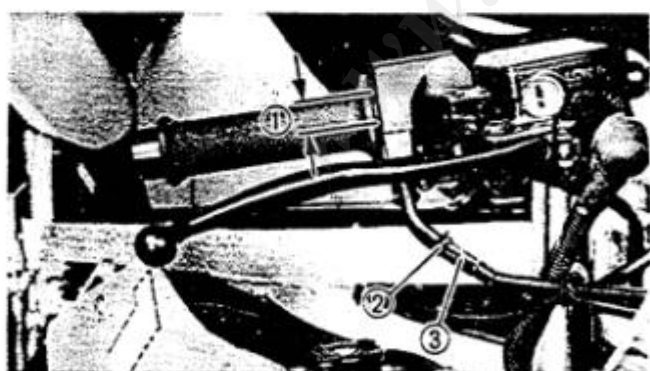

2. Check:
 - Throttle cable free play ①
Out of specification → Adjust.

Throttle Cable Free Play ①:
3 ~ 7 mm (0.12 ~ 0.28 in)

3. Adjust:
 - Throttle cable free play

Throttle cable adjustment step (2):

- Loosen the adjuster locknut ②.
- Adjust the free play by turning the adjuster ③ in or out.
- Tighten the locknut.

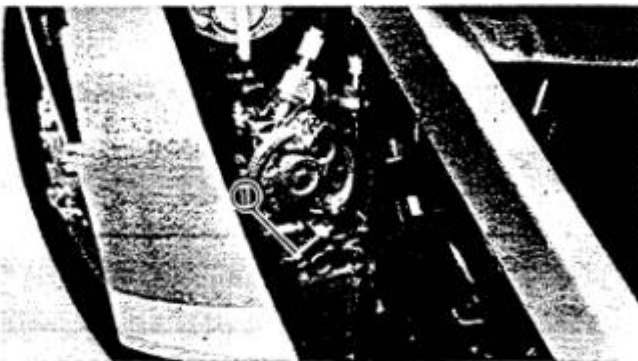
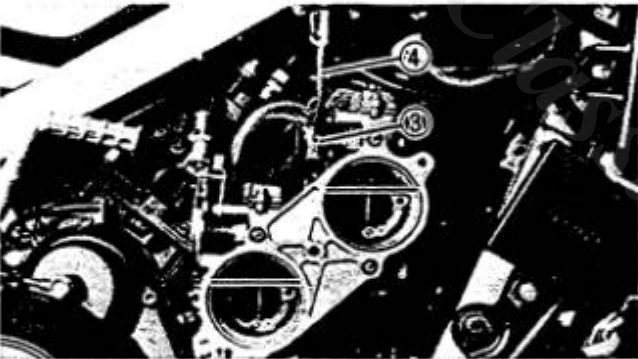
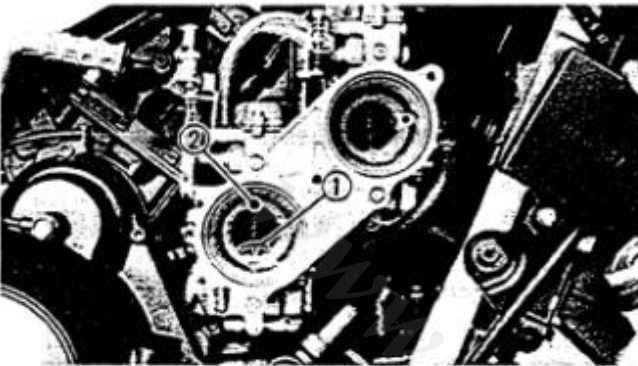
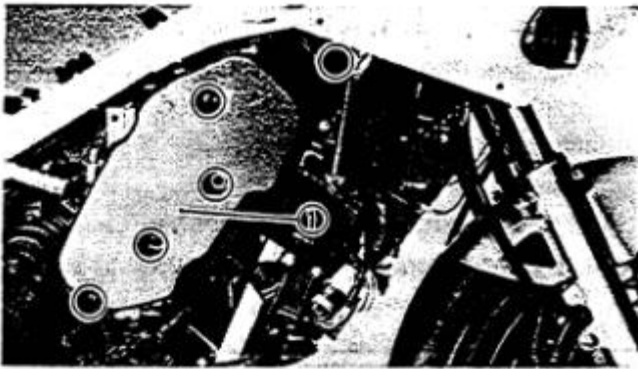

CARBURETOR SYNCHRONIZATION

1. Remove:
 - Lower cowling
 - Center cowlings
 - Air ducts ①
2. Check:
 - Carburetor synchronization
Incorrect → Adjust.

Carburetor synchronization adjustment steps:

- Slowly turn the throttle grip until the cutaway convex center of the throttle valve ① in the lower carburetor is flush with the carburetor bore top ②.
- While keeping the grip at this point, check the throttle valve position in the upper carburetor. This position must be the same as in the lower carburetor.
- If not, adjust the throttle valve in the upper carburetor by turning the synchronizing screw ③.
- Adjust the other carburetor in the same manner as in the above.

④ Screw driver

IDLE SPEED

1. Adjust
 - Idle speed
Warm up the engine and turn the throttle stop screw ① to adjust.



Engine Idle Speed:
1.250 r/min

Idle speed adjustment steps:

NOTE: _____
The throttle cables and synchronization must be set properly before adjusting the idle speed.

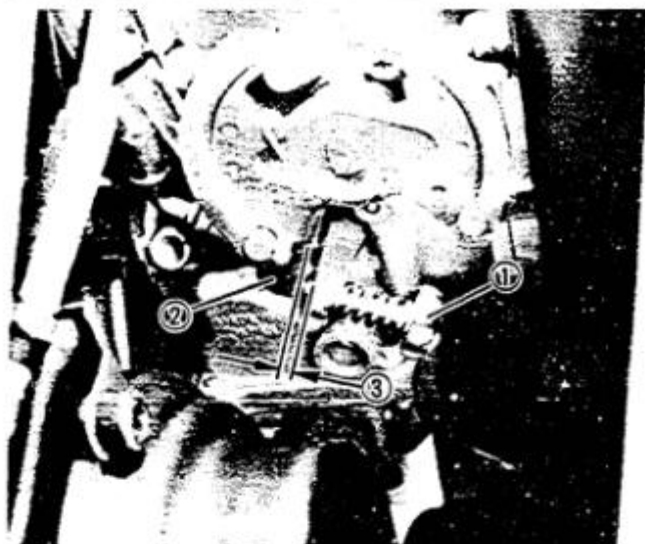

- Loosen both throttle stop screws until the stop screw ① and throttle pulley stopper ② have clearance ③ between them.
- Slowly turn the throttle stop screw until the stop screw end just contacts the throttle pulley stopper.
- Turn the other throttle stopper screw in the same manner as in the above.
- Warm up the engine and turn both throttle stop screws simultaneously by the same amount.
- Set the idle to the specified engine speed.



Engine Idle Speed:
1.250 r/min

4. Screwdriver

YPVS (YAMAHA POWER VALVE SYSTEM)

The YPVS operation can be heard in the following instances:

- When the main switch is turned on and the engine is started.
- When the engine stalls while the main switch is on.

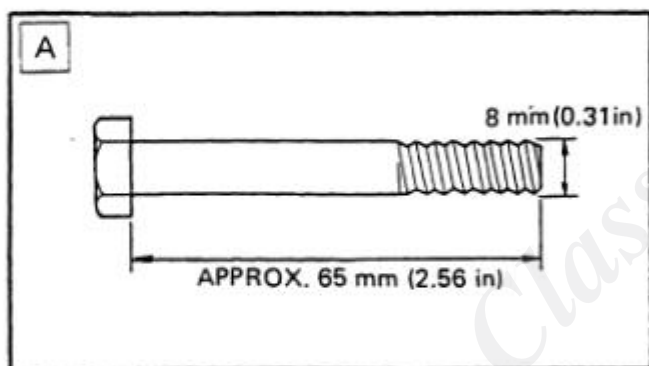

YPVS Adjustment

YPVS cable adjustment step:

- Turn the main switch on and wait for five(5) seconds; then, turn the main switch off.
- Insert the specified size of bolts **A** (as shown) into the cylinders to hold each of the YPVS's.
- Loosen the YPVS cable adjuster locknut ②.
- Turn the adjuster ③ clockwise until it stops completely; then, loosen the adjuster a half(1/2) turn.
- Tighten the adjuster locknut.
- Adjust the other cable in the same manner as in the above.
- Tighten the locknut.

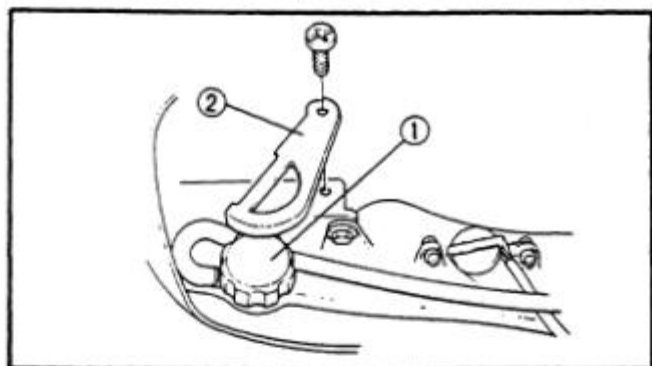

ENGINE OIL



Recommended Oil:
Yamaha Oil 2T or Equivalent
Air Cooled 2-stroke Oil
Oil Capacity:
2.0 L (1.8 Imp qt, 2.1 US qt)

- ① Oil tank filler cap
- ② Cap retainer

Oil Level Measurement

1. Check:
 - Oil level

Oil level low, → Add sufficient oil.

OIL LEVEL AND "OIL" LIGHT CHECKING METHOD

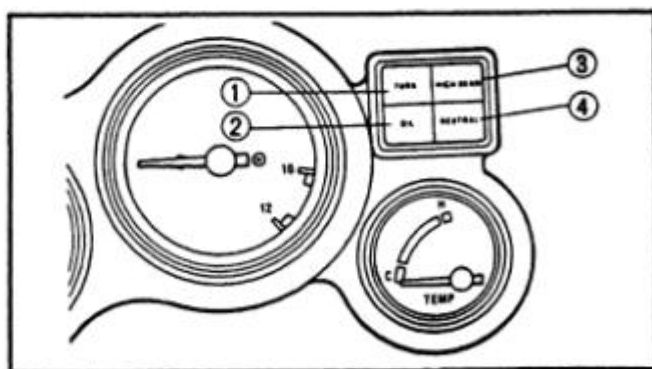
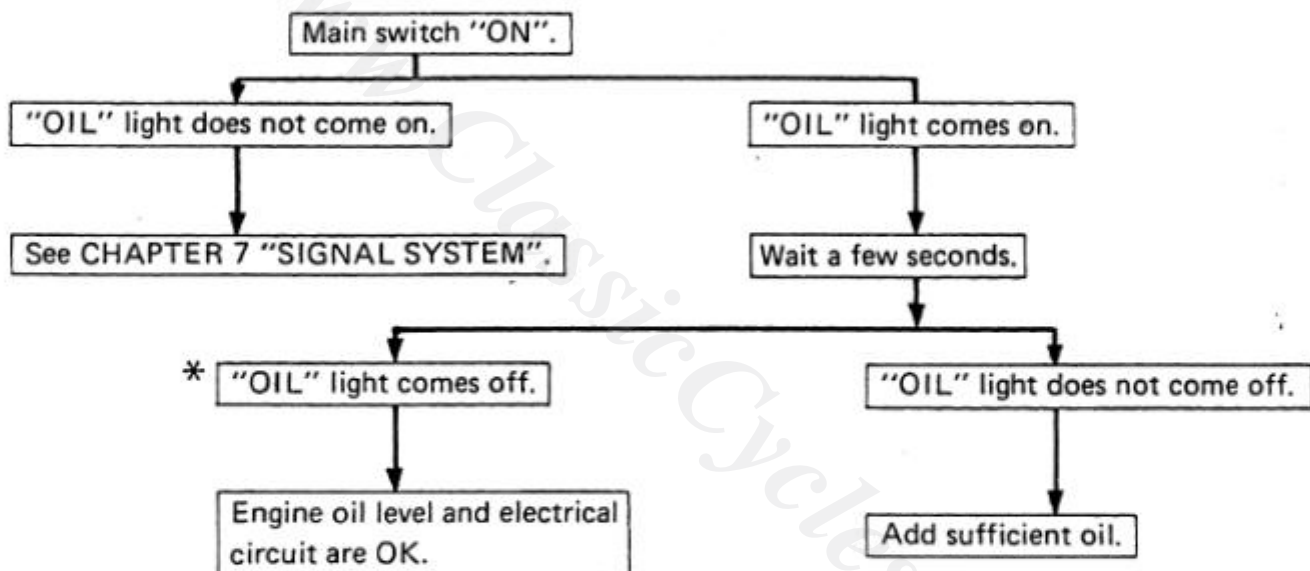

NOTE:

* If the main switch is turned off after the "OIL" light goes off and then immediately again the main switch is turned on, the "OIL" light may not come on. This is not because of failure.

- ① "TURN" indicator light
- ② "OIL" warning indicator light
- ③ "NEUTRAL" indicator light
- ④ "HIGH BEAM" indicator light

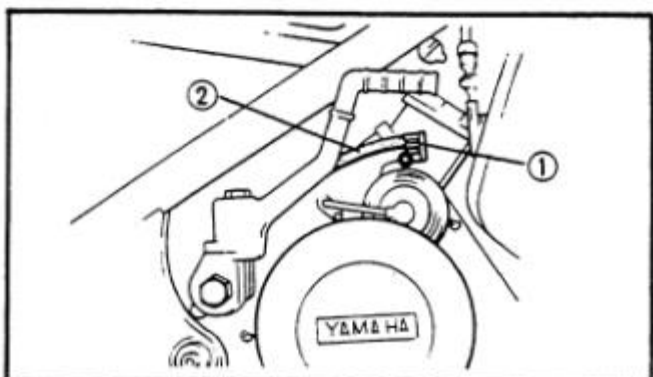
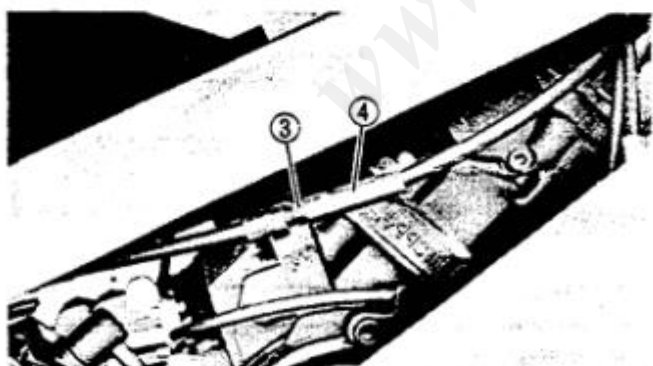
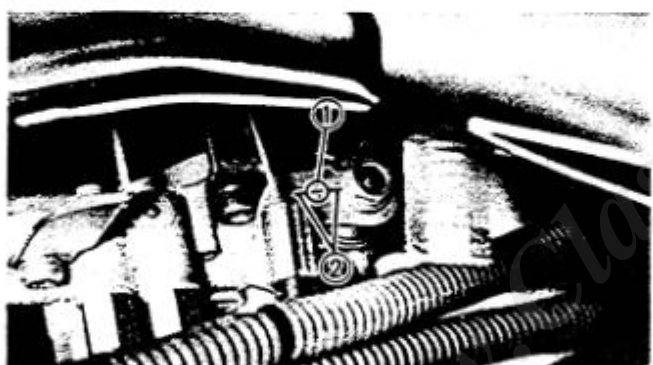
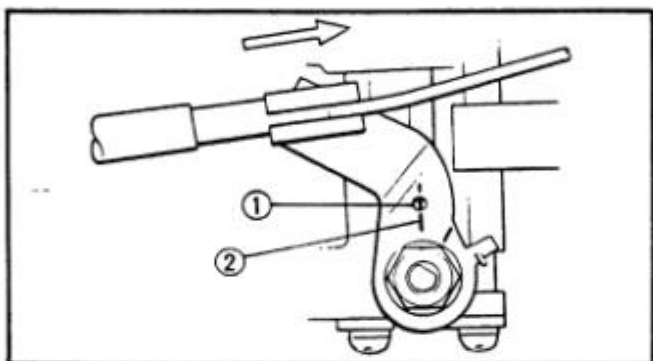
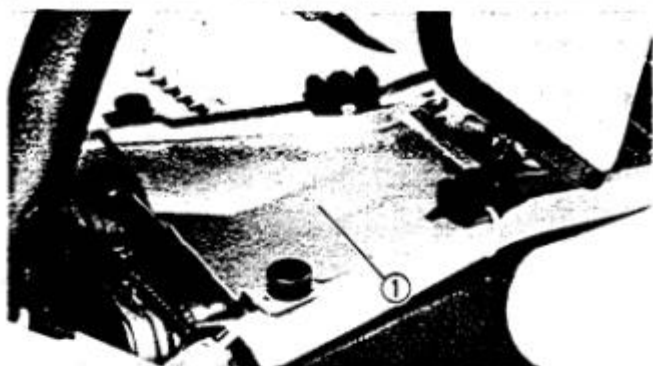

OIL PUMP

Oil Pump Cable Adjustment

1. Remove:
 - Bolt (Fuel tank)
2. Pull up the fuel tank. Use the fuel tank holding wire.
3. Remove:
 - Heat protector ①
4. Turn the main switch on.
5. Check:
 - Oil pump control position
Not aligned → Adjust.

Oil pump cable adjustment steps:

- Turn the main switch on.
- Twist the throttle grip a little so that the throttle cable has no free play.
- In this case, the control lever hole center ① should be aligned with the mark on the oil pump ②.
- If not, loosen the oil pump cable adjuster locknut ③ and turn the adjuster ④ for the above alignment.
- Tighten the cable locknut.

Air Bleeding

The oil pump (engine oil) and delivery lines must be bled on the following occasions:

- Setting up a new motorcycle out of the crate.
- Whenever the oil tank has run dry.
- Whenever any portion of the engine oil system is disconnected.

Air bleeding steps:

- Remove the clip ①, and disconnect the bleed pipe ②.
- Keep the oil running out until air bubbles disappear.
- When air bubbles are expelled completely, connect the pipe. Then, secure the pipe with the clip.



TRANSMISSION OIL

	Recommended Oil:
	SAE 10W30 type SE motor oil
	Total Amount:
	1.6 L (1.4 Imp qt, 1.7 US qt)
	Periodic Oil Change:
	1.5 L (1.3 Imp qt, 1.6 US qt)

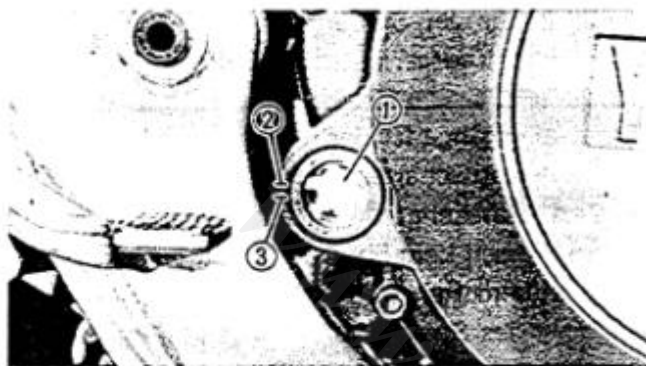

Oil Level Measurement

1. Check:
 - Oil level

Oil level low → Add sufficient oil.

Oil level visual inspection steps:

- Place the motorcycle on a level surface and warm up the engine for several minutes.

NOTE:

Position the motorcycle straight up when checking oil level, a slight tilt to the side can produce false readings.

- Stop the engine and visually check the oil level through the level window ①.

NOTE:

Wait several minutes until the oil level settles before checking.



- ② Maximum
- ③ Minimum

Periodic Oil Change

1. Warm up the engine for several minutes, then place a receptacle under the engine.
2. Remove:
 - Lower cowling
 - Oil filler cap ①
3. Remove:
 - Drain plug ②

Drain the transmission oil.
4. Tighten:
 - Drain plug ②

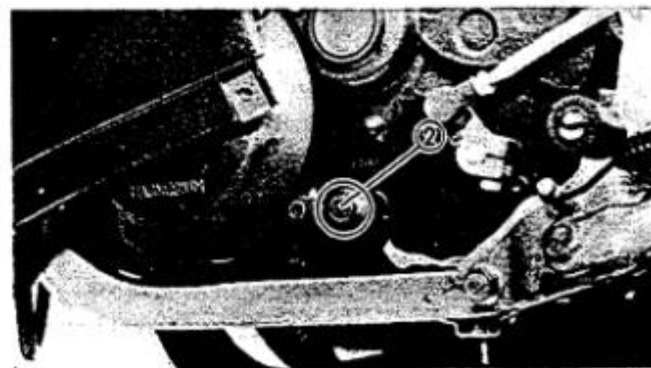

	Drain Plug:
	22 Nm (2.2 m·kg, 16 ft·lb)



5. Fill:
- Crankcase



Transmission Oil:
1.5 L (1.3 Imp qt, 1.6 US qt)

CAUTION:

Do not allow foreign material to enter the crankcase.

6. Install:
- Filler cap
 - Lower cowling

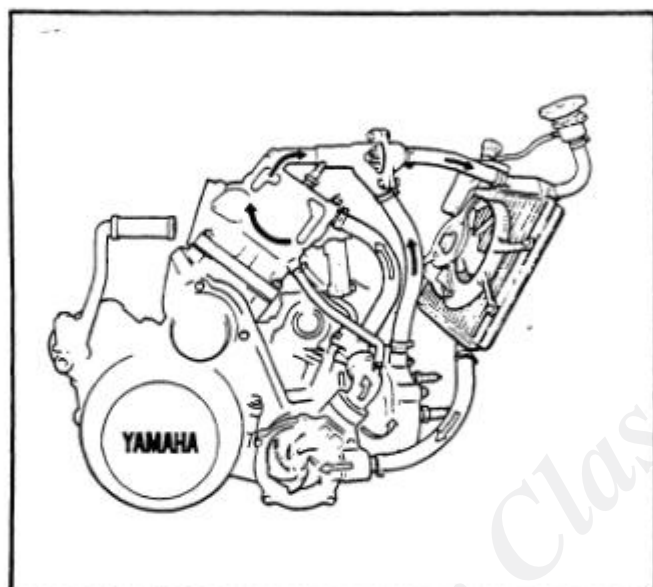

COOLANT



Recommended Coolant:
High Quality Ethylene Glycol
Anti-freeze Containing
Anti-corrosion for
Aluminum Engine Inhibitors
Coolant and Water Mixed Ratio:
50%/50%
Total Amount:
1.95 L (1.72 Imp qt, 2.06 US qt)
Reservoir Tank Capacity:
0.35 L (0.31 Imp qt, 0.37 US qt)
From "LOW" to "FULL" Level:
0.25 L (0.22 Imp qt, 0.26 US qt)

WARNING:

Do not remove the radiator cap when the engine and radiator are hot. Scalding hot fluid and steam may be blown out under pressure, which could cause serious injury. When the engine has cooled, open the radiator cap by the following procedure: Place a thick rag, like a towel, over the radiator cap, slowly rotate the cap counterclockwise to the detent. This procedure allows any residual pressure to escape. When the hissing sound has stopped, press down on the cap while turning counterclockwise and remove it.

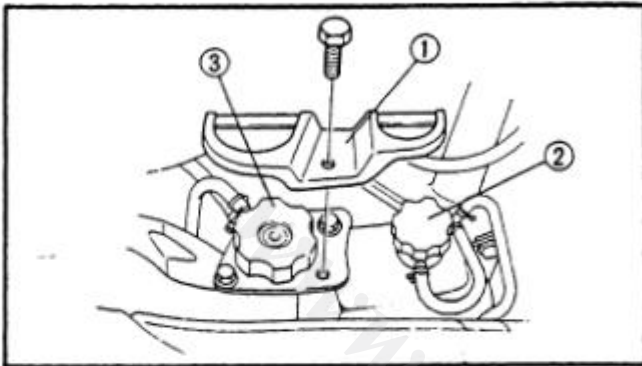
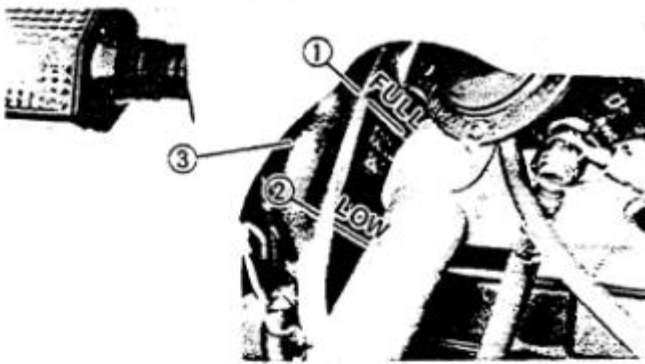

Coolant Level Check

1. Check:
 - Coolant level
 - Coolant level low → Add sufficient coolant.

- ① "FULL" level
- ② "LOW" level
- ③ Reservoir tank

2. Remove:
 - Cap retainer ①
 - Reservoir tank cap ②
3. Add:
 - Coolant

③ Radiator cap

CLUTCH ADJUSTMENT

Clutch Lever Free Play Adjustment

1. Loosen:
 - Adjuster locknut ①
2. Adjust:
 - Free play ③
 - Turn the adjuster ② clockwise or counterclockwise until proper lever free play is attained.

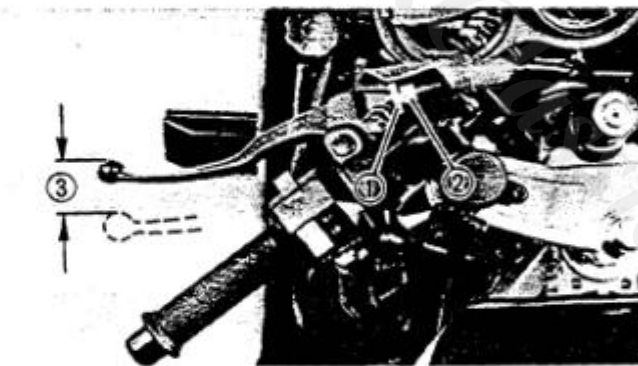

Clutch Lever Free Play ③:
8 ~ 12 mm (0.31 ~ 0.47 in)

3. Tighten:
 - Locknut

Mechanism Adjustment

1. Loosen:
 - Clutch cable
2. Remove:
 - Adjuster cover ①
3. Loosen:
 - Locknut ②
 - Use the Clutch Adjusting Tool (90890-01204) ③

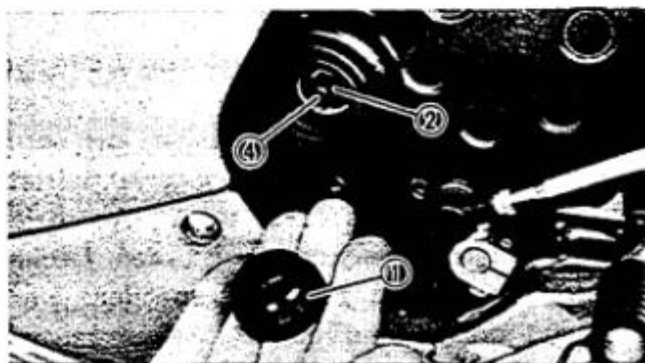

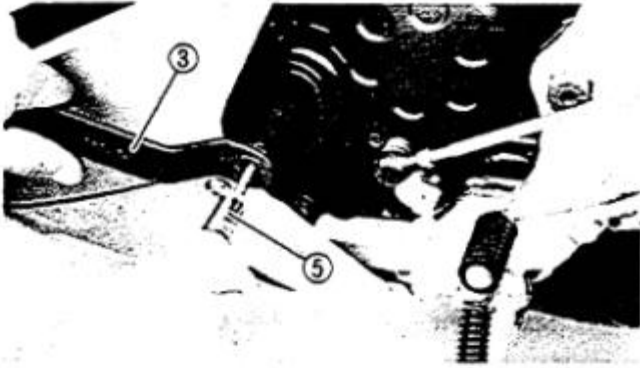

4. Rotate:
 - Adjuster ④
Turn it clockwise until it lightly seats against clutch push rod; then, return the adjuster a quarter (1/4) turn.

NOTE:

Be sure the screw contacts push rod firmly but lightly.

5. Tighten:
 - Locknut
- ③ Screwdriver

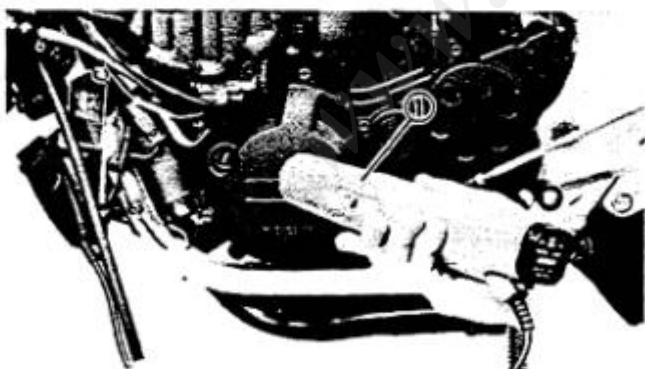
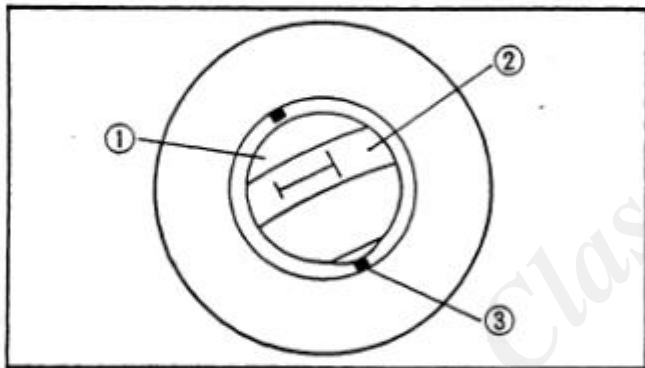

IGNITION TIMING CHECK

- ① Timing window
- ② Firing range for No. 2 and No. 3 cylinder
- ③ Stationary pointer on crankcase cover

1. Remove:
 - Lower cowling
 - Center cowling (Left)
 - Timing plug
2. Check:
 - Ignition timing

Ignition timing check steps:

- Connect the Timing Light (90890-03109) ① to No. 2 or No. 3 cylinder spark plug lead.
- Warm up the engine and let it idle at the specified idle speed of 1,250 r/min.
- Visually check the stationary pointer in the timing window to verify it is within the required firing range indicated on the flywheel.

Incorrect firing range → Check timing plate and/or pickup assembly (tightness damage)

Refer to CHAPTER 7. "ELECTRICAL" for further information.



CHASSIS

DRIVE CHAIN

1. Measure:
 - Drive chain slack

Motorcycle is on a level surface.
Out of specification → Adjust.

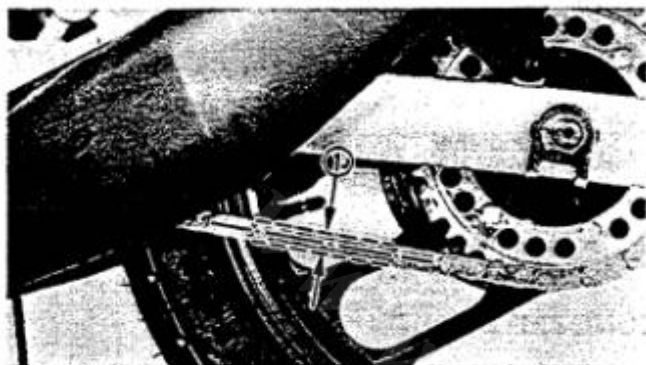

Drive chain slack measurement steps:

- Turn the rear wheel several times.
- Check the chain slack several times to find the point where the chain is the tightest.
- Check the chain slack when the wheel is in this "tight chain" position.



Drive Chain Slack ①:
15 ~ 20 mm (0.6 ~ 0.8 in)

- If the chain slack exceeds 20 mm (0.8 in), adjust the chain slack.

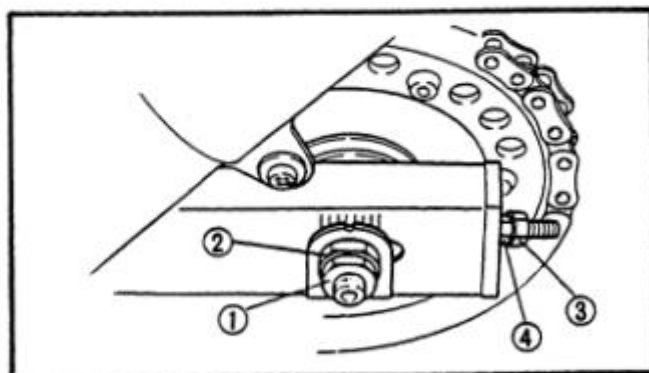

Drive chain slack adjustment steps:

- Loosen the axle locknut ①
- Loosen the axle nut ②
- Loosen the locknuts ③
- Adjust chain slack by turning the adjuster unit ④.

To Tighten → Turn adjuster nut clockwise.
To Loosen → Turn adjuster nut counterclockwise and push wheel forward.

- Turn each nut exactly the same amount to maintain correct axle alignment.

CAUTION:

Excessive chain slack will overload the engine and other vital parts; keep the slack within the specified limits.

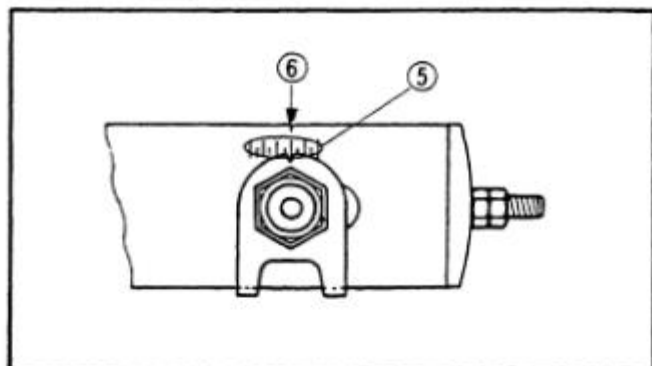

(There are marks on each side of the swingarm ⑤ and on each chain puller alignment.)

- Check the alignment mark. If the alignment mark exceeds wear limit ⑥, replace the sprockets and drive chain as a set.
- Tighten the axle nut and locknuts.



Axle Nut:

105 Nm (10.5 m·kg, 75 ft·lb)

Locknut:

60 Nm (6.0 m·kg, 43 ft·lb)

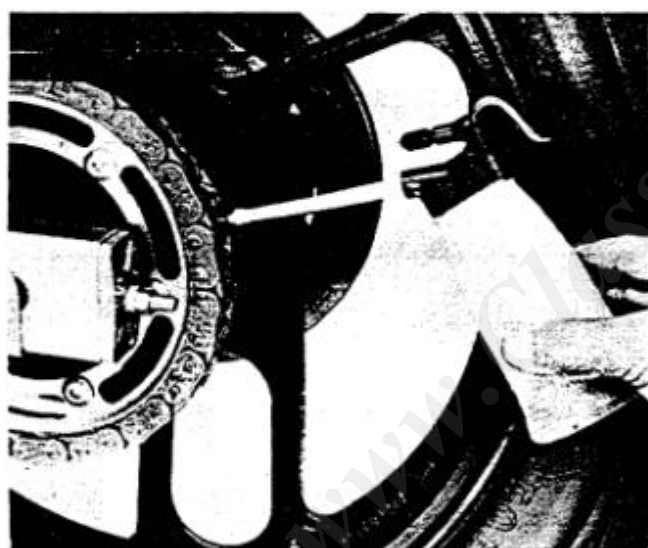

Drive Chain Lubrication

The chain consists of many parts which work against each other. If the chain is not maintained properly, it will wear out rapidly, therefore, form the habit of periodically servicing the chain. This service is especially necessary when riding in dusty conditions.

This motorcycle has a drive chain with small rubber O-rings between the chain plates. Steam cleaning, high-pressure washes, and certain solvents can damage these O-rings. Use only kerosene to clean the drive chain. Wipe it dry, and thoroughly lubricate it with SAE 30 ~ 50W motor oil. Do not use any other lubricants on the drive chain. They may contain solvents that could damage the O-rings.

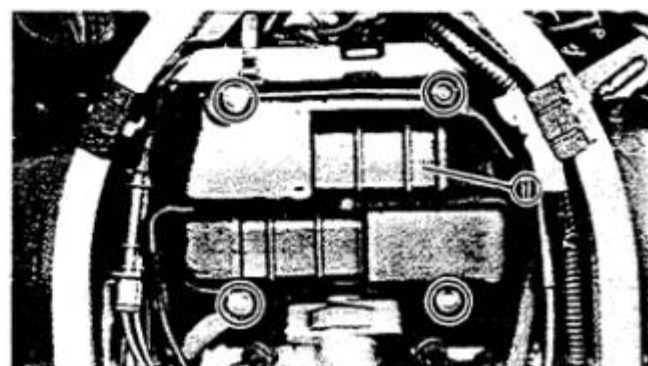

AIR FILTER

1. Remove:
 - Seat
 - Bolt (Fuel tank)
2. Pull up the fuel tank.
3. Remove:
 - Cover (Air filter) ①

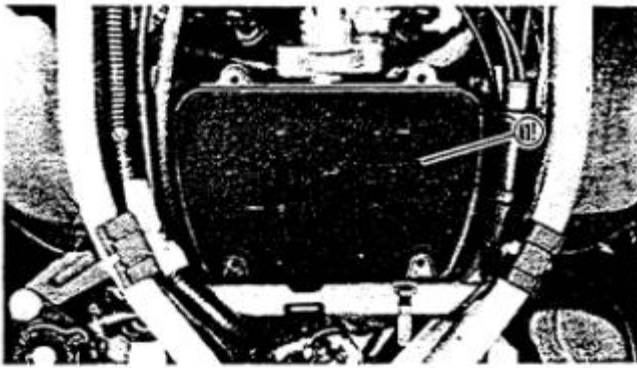

4. Remove:
 - Element ①

Air cleaner element cleaning steps:

- Clean the element with solvent.
- After cleaning, remove the remaining solvent by squeezing the element.
- Apply Yamaha oil 2T or air-cooled 2-stroke engine oil to the entire surface of the element and squeeze out the excess oil.

NOTE: _____
 The element should be wet but not dripping.

5. Install:
 - Element

CAUTION: _____

Make sure the element edge fits into the corresponding filter case groove.

- Cover (Air filter)
- Fuel tank
- Seat

www.classiccyclery.com

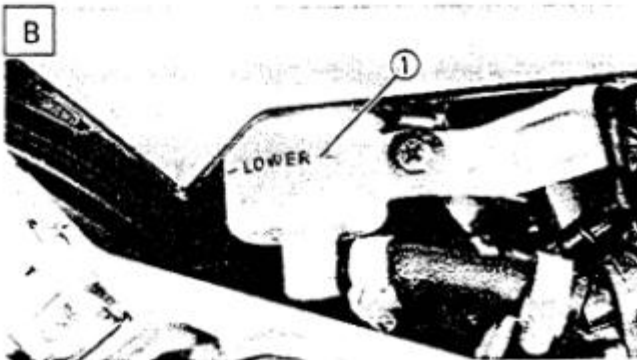
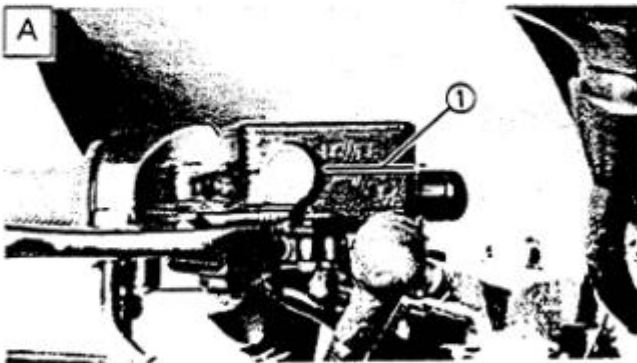

BRAKE FLUID INSPECTION

1. Check:
 - Brake fluid level
 - Low level ① → Replenish.

NOTE: _____
 Use only a designated, quality fluid.

	Brake Fluid: DOT NO. 3
--	-----------------------------------

NOTE: _____

Be sure that:

- Water does not enter the master cylinder when refilling.
- Spilled fluid is cleaned up immediately to prevent painted surfaces or plastic parts from eroding.

- Ⓐ FRONT BRAKE
 Ⓑ REAR BRAKE

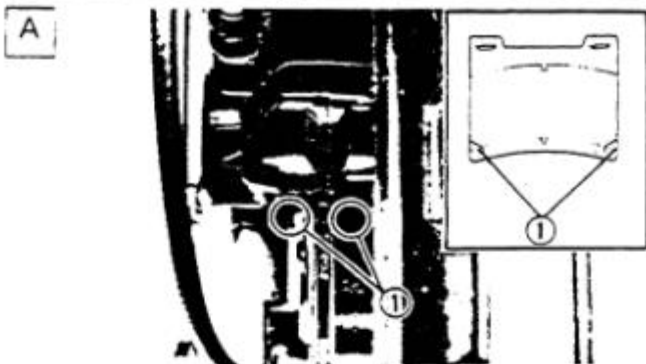

FRONT AND REAR BRAKE PAD INSPECTION

1. Activate the brake lever or brake pedal.
2. Inspect:
 - Wear indicator ①
 Indicator almost contacts disc → Replace pads.
 Refer to CHAPTER 6, "CHASSIS."

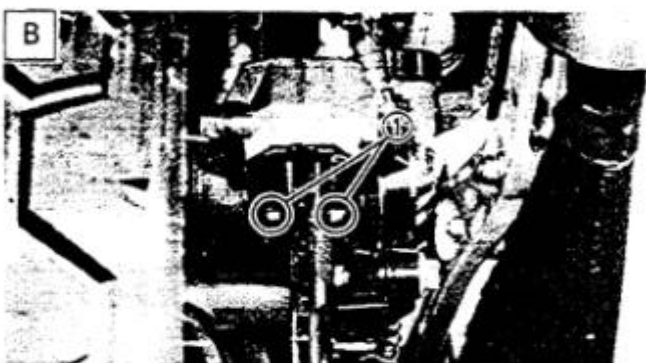

- A** FRONT BRAKE
B REAR BRAKE

FRONT BRAKE

Front Brake Lever Free Play Adjustment

1. Loosen:
 - Adjuster locknut ①
2. Adjust:
 - Free play
 Turn the adjuster ② until the free play ③ is within the specified limits.



Brake Lever Free Play ③:
1 ~ 2 mm (0.04 ~ 0.08 in)

CAUTION:

Proper lever free play is essential to avoid excessive brake drag.

3. Tighten:
 - Adjuster locknut

REAR BRAKE

Rear Brake Pedal Height Adjustment

1. Loosen:
 - Adjuster lock nuts ①
2. Adjust:
 - Brake pedal height
 Turn the adjuster ② until the brake pedal position is at the specified height.

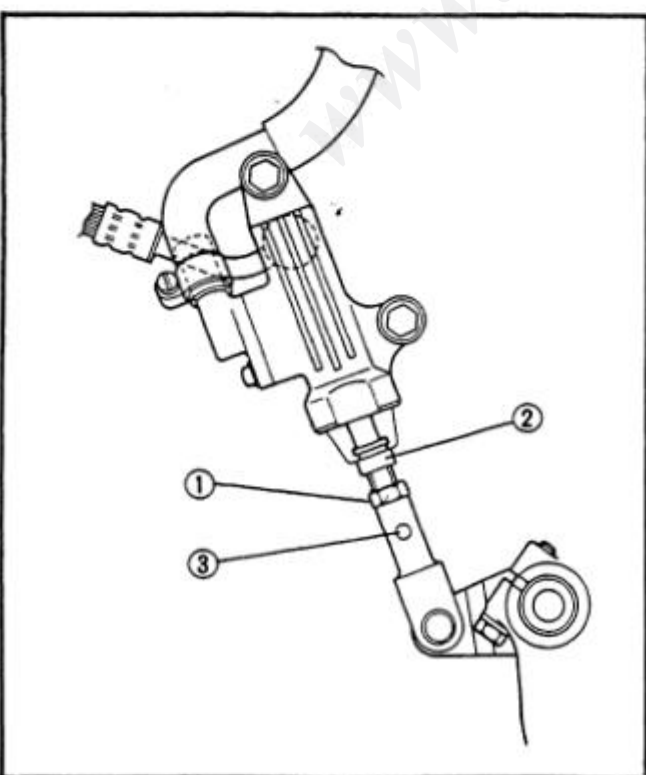

③ Hole

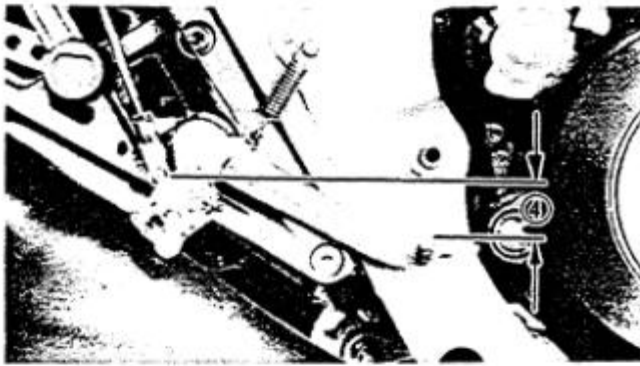

Brake Pedal Height ④ :
50 ~ 60 mm (2.0 ~ 2.4 in)
Below the Top of the Footrest

WARNING:

After adjusting the brake pedal height, visually check the adjuster end through the hole ③ of the joint holder. The adjuster end must appear within this hole.

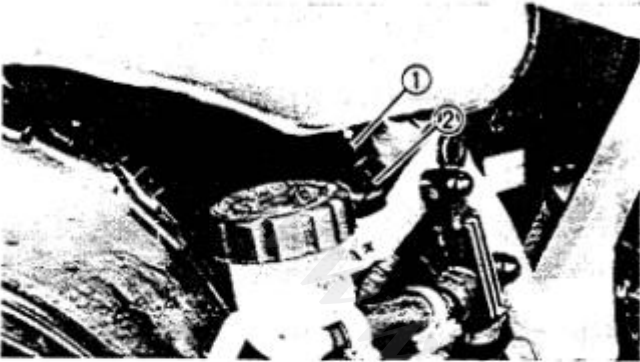
**Brake Light Switch Adjustment**

1. Hold the switch body ① with your hand so that it does not rotate and turn the adjusting nut ②.

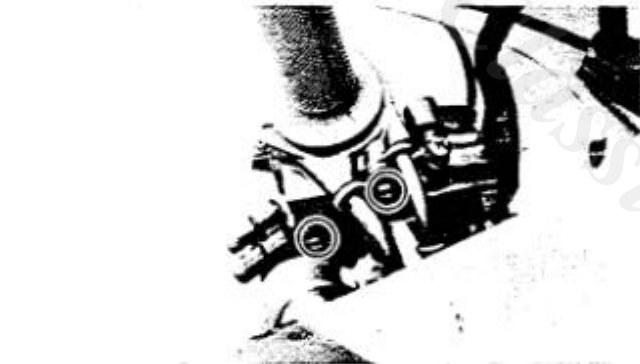
**CABLE INSPECTION AND LUBRICATION****Cable inspection and lubrication steps:**

- Remove the two screws that secure throttle housing to handlebar.
- Hold cable end high and apply several drops of lubricant to cable.
- Coat metal surface of disassembled throttle twist grip with suitable all-purpose grease to minimize friction.
- Check for damage to cable insulation. Replace any corroded or obstructed cables.
- Lubricate any cables that do not operate smoothly.

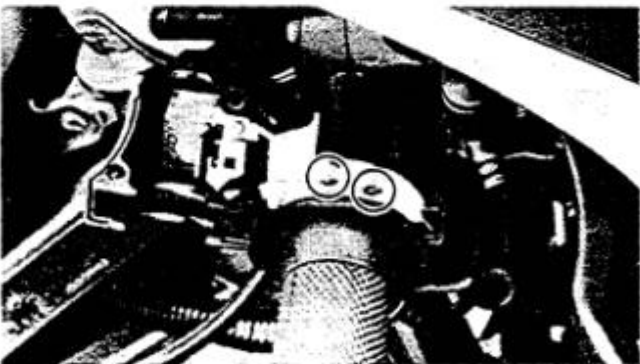

SAE 10W30 Motor Oil

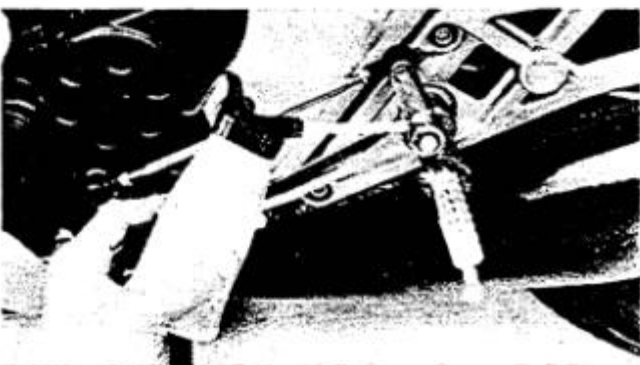
**BRAKE AND CHANGE PEDALS/BRAKE AND CLUTCH LEVERS**

Lubricate pivoting parts of each lever and pedal.



SAE 10W30 Motor Oil

**SIDESTAND**

Lubricate sidestand pivot point.

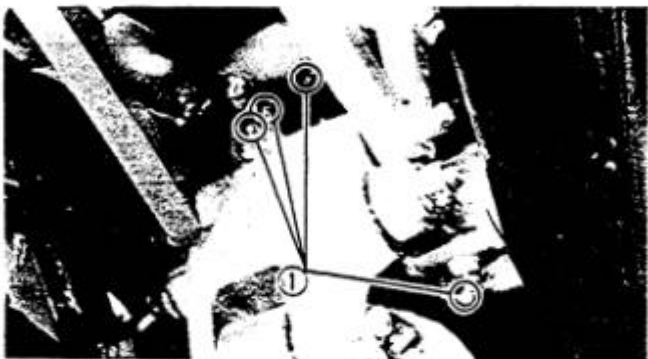
**SAE 10W30 Motor Oil****SWINGARM AND RELAY ARM**

Lubricate the swingarm and relay arms at their pivoting points.

**Lightweight Lithium-soap
Base Grease**

① Grease nipple



FRONT FORK OIL CHANGE

- | | |
|-------------------|------------------------------|
| 1. Fork cap | 12. Inner fork tube |
| 2. Cap bolt | 13. Circlip |
| 3. O-ring | 14. Washer |
| 4. Dust seal | 15. Oil seal |
| 5. Collar | 16. Guide bushing |
| 6. Spring seat | 17. Outer fork tube |
| 7. Fork spring | 18. Plunger case |
| 8. Damper rod | 19. Anti-dive |
| 9. Wave washer | 20. Drain screw |
| 10. Washer | 21. Damper rod assembly bolt |
| 11. Taper spindle | |

T-HANDLE: P/N. 90890-01326 DAMPER ROD HOLDER (27 mm) P/N. 90890-01388
FRONT FORK CAP SOCKET (17 mm) P/N. 90890-01104

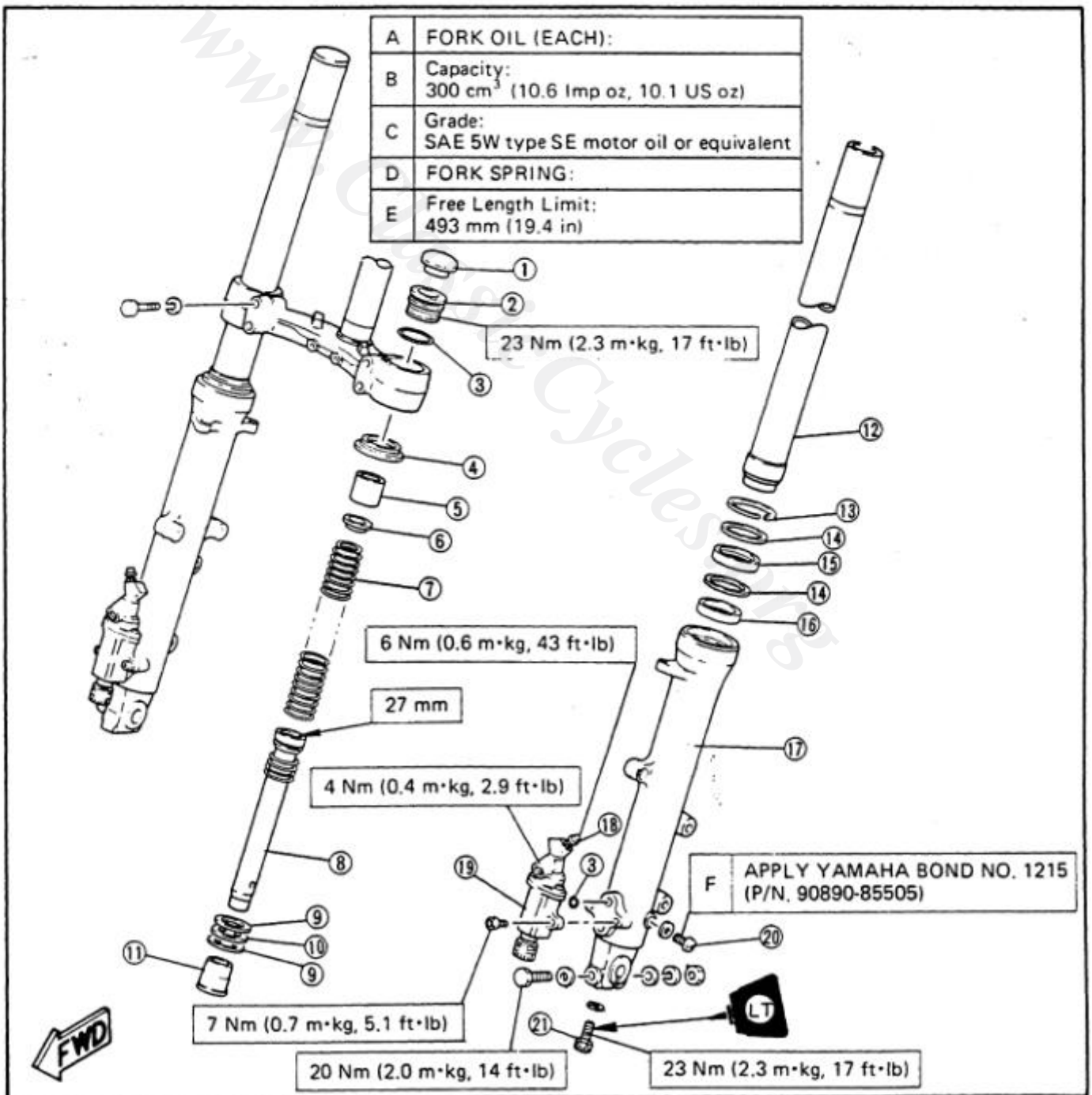

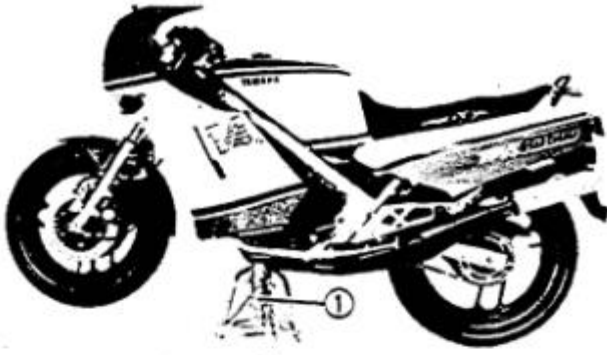

1. Remove:
 - Lower cowling
2. Place the motorcycle on a block or other suitable stand ① under the frame.

WARNING:

Securely support the motorcycle so there is no danger of it falling over.

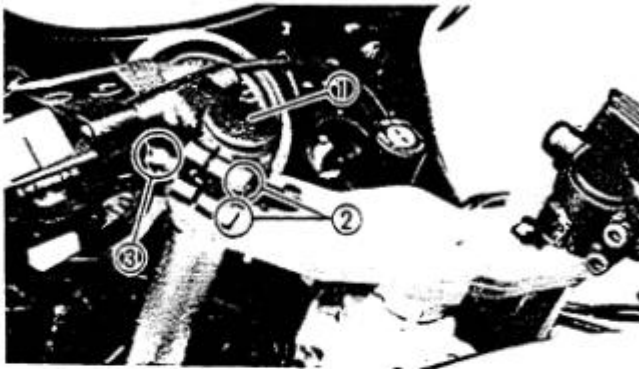

3. Remove:
 - Fork caps ①
4. Loosen:
 - Pinch bolts (Handlebar) ②
 - Pinch bolts (Steering crown) ③



5. Remove:
 - Cap bolt
Use the Front Fork Cap Socket 17 mm (90890-01104) ①.
 - Collar
 - Spring seat
 - Fork spring

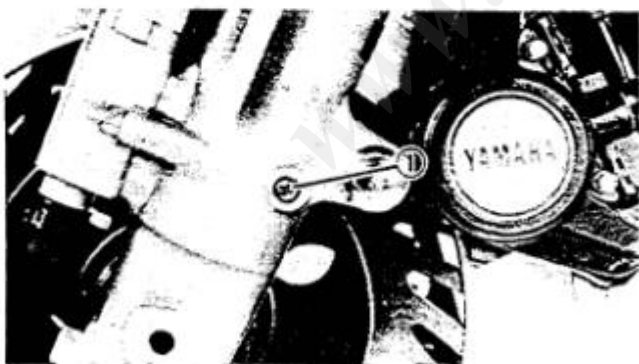

6. Remove:
 - Drain screws ①
Drain the fork oil.

WARNING:

Do not allow any oil to contact the disc brake components. If oil is discovered be sure to remove it, otherwise diminished braking capacity and damage to the rubber components of the brake assembly will occur.

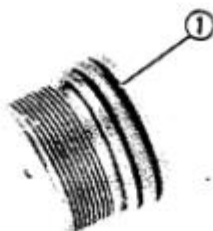

7. Inspect:
 - O-ring ①
 - Gasket (Drain screw)
Wear/Damage → Replace.
8. Install:
 - Drain screws



9. Fill:
- Front forks



Each Fork:
300 cm³ (10.6 Imp oz, 10.1 US oz)
SAE 5W Type SE Motor Oil
or equivalent

After filling, pump the forks slowly up and down to distribute the oil.



10. Install:
- Fork spring ①
(with smaller pitch side up)
 - Spring seat ②
 - Collar ③
 - Cap bolt ④



11. Tighten:
- Cap bolt
Use the Front Fork Cap Socket 17 mm (90890-01104) ①.
 - Pinch bolts (Handlebar)
 - Pinch bolts (Steering crown)



Cap Bolt:
23 Nm (2.3 m·kg, 17 ft·lb)
Pinch Bolt (Handlebar)
20 Nm (2.0 m·kg, 14 ft·lb)
Pinch Bolt (Steering Crown)
20 Nm (2.0 m·kg, 14 ft·lb)



REAR SHOCK ABSORBER ADJUSTMENT

1. Tension bar
2. Collar
3. Oil seal
4. Circlip
5. Bearing
6. Collar
7. Dust seal
8. O-ring
9. Bushing

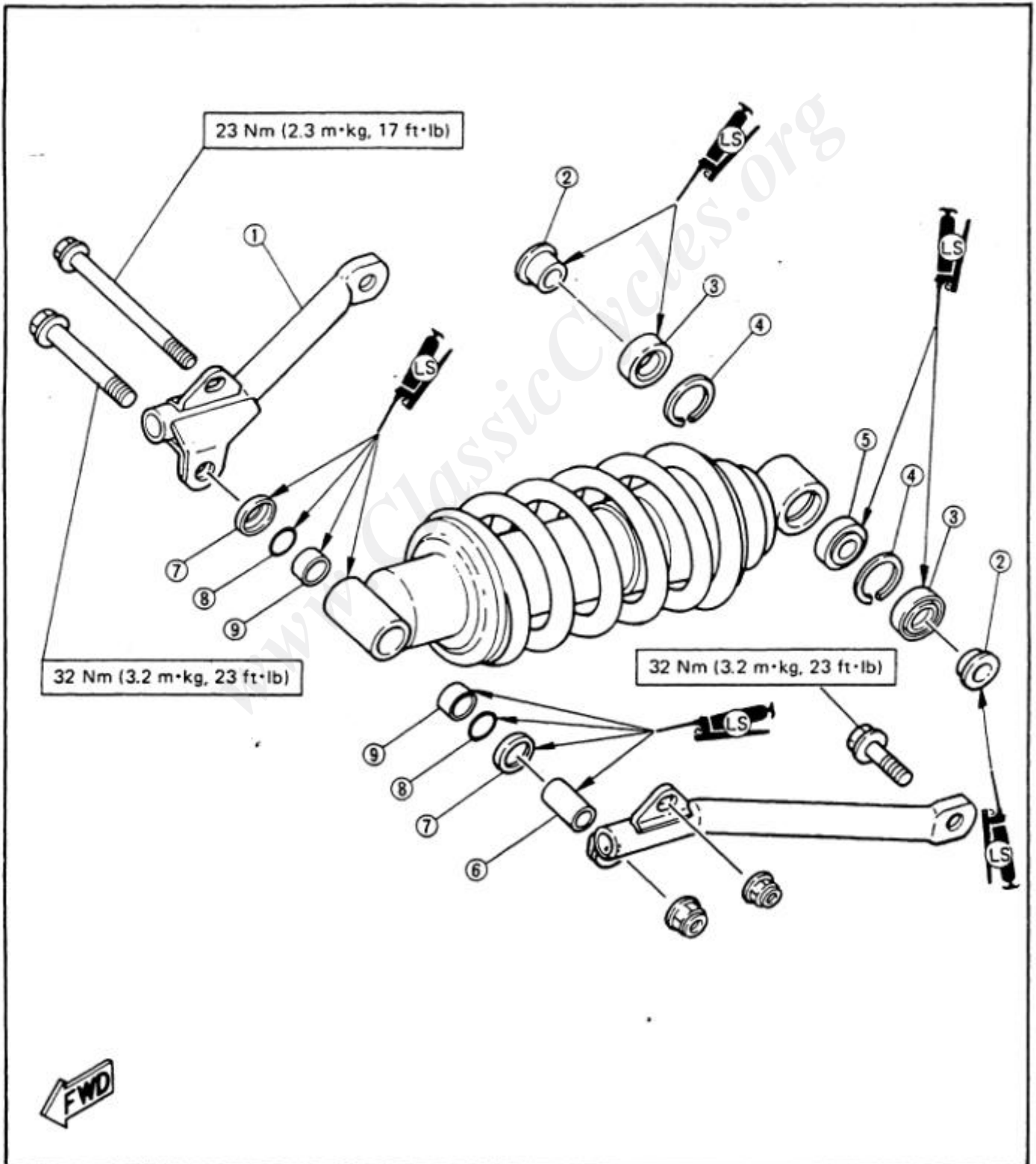

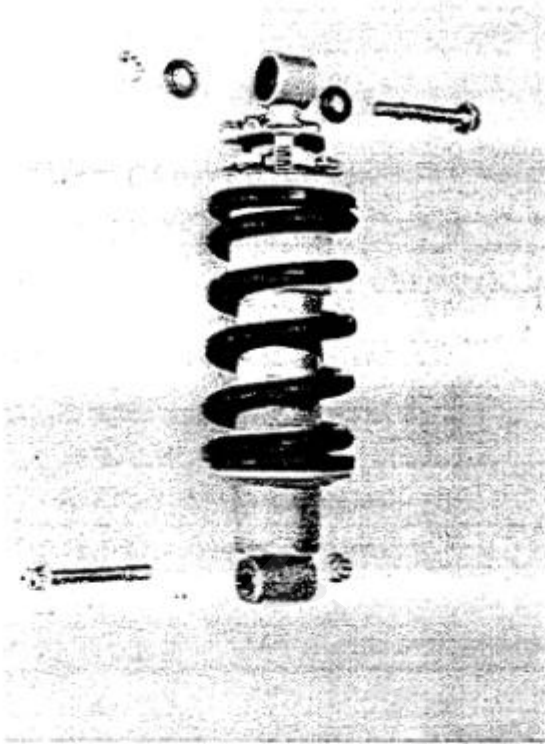

Rear Shock Absorber
(Monocross suspension "De Carbon" system)

WARNING:

This shock absorber contains highly pressurized nitrogen gas.

Read and understand the following information before handling the shock absorber. The manufacturer cannot be held responsible for property damage or personal injury that may result from improper handling.

1. Do not tamper with or attempt to open the cylinder assembly.
2. Do not subject shock absorber to an open flame or other high heat source. This may cause the unit to explode due to excessive gas pressure.
3. Do not deform or damage the cylinder in any way. Cylinder damage will result in poor damping performance.

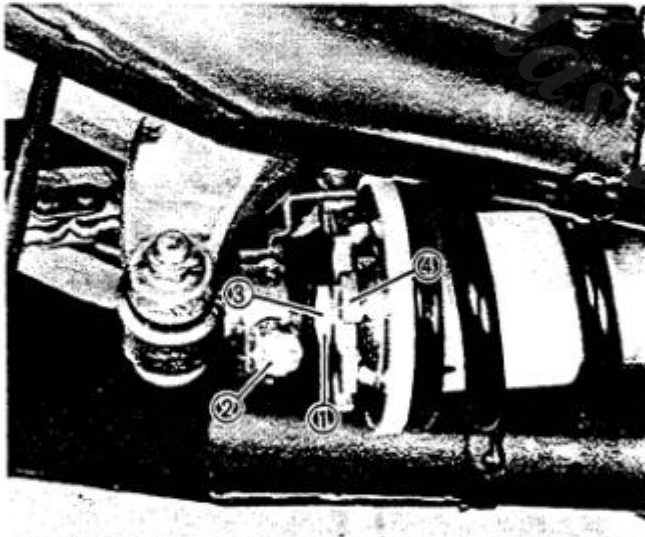

Rear Shock Absorber Adjustment

1. Adjust:
 - Spring preload ①
 - Damping ②

The rear shock absorber of this model features a spring preload adjuster which is a combined spring preload and damping adjuster. Normal adjustment can be made by turning this spring preload adjuster, whereas damping adjustment can only be made by the damping adjuster.

- ③ Locknut
- ④ Adjuster

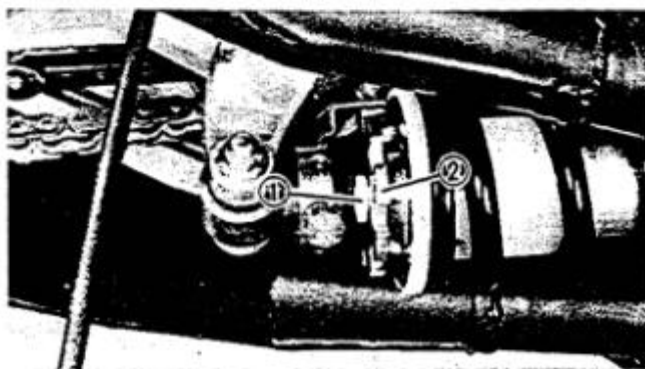

Spring preload adjustment steps:

- Loosen the adjuster locknut ①, and turn the adjuster ②.

NOTE:

When adjusting, use the special wrenches which are included in the owner's tool kit.



ANTI-DIVE ADJUSTMENT

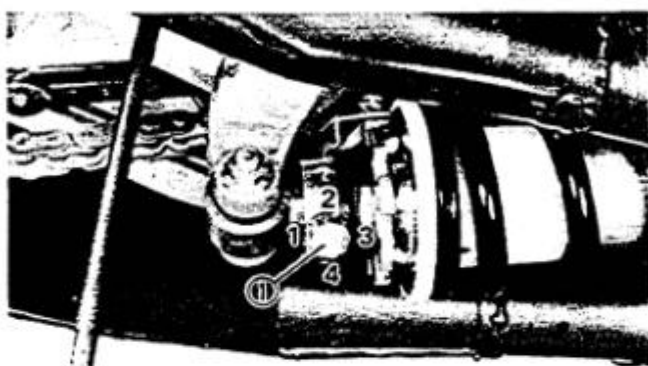

Hard → Turn the adjuster clockwise.
Soft → Turn the adjuster counterclockwise.

	HARD				STD
Adjusting position	5	4	3	2	1

• Tighten the adjuster locknut.



Adjuster Locknut:
42 Nm (4.2 m·kg, 30 ft·lb)

Damping adjustment steps:

Soft → Turn the adjuster ① clockwise.
Hard → Turn the adjuster counterclockwise.

	HARD	STD	SOFT	
Adjusting position	4	3	2	1

CAUTION:

Turn the damping adjuster from 1 to 4 or 4 to 1 in progressive steps (1, 2, 3, 4). Never turn adjuster directly from 1 to 4 or 4 to 1.

ANTI-DIVE ADJUSTMENT

This anti-dive is adjustable in four stages depending on loading conditions.

WARNING:

Always adjust each anti-dive to the same setting. Uneven adjustment can cause poor handling and loss of stability.

Hard → Turn the adjuster ① counterclockwise.
Soft → Turn the adjuster clockwise.
Standard Position: "1"
Maximum Position: "4"

- A** Minimum
- B** Maximum

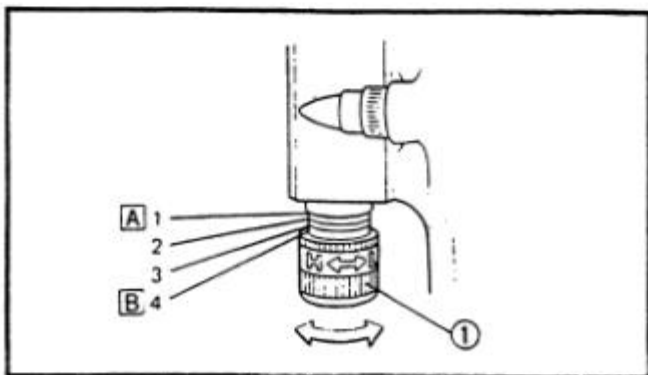



Adjusting bolt position	Loading condition		
	Solo rider	With accessory equipment or passenger	With accessory equipment and passenger
1	○		
2	○	○	
3		○	○
4			○

www.ClassicCycles.org

STEERING HEAD ADJUSTMENT

- | | |
|---------------------|---------------------|
| 1. Handlebar | 7. Ring nut (Lower) |
| 2. Nut | 8. Bearing cover |
| 3. Steering crown | 9. Bearing (Upper) |
| 4. Lock washer | 10. Bearing (Lower) |
| 5. Ring nut (Upper) | 11. Steering stem |
| 6. Rubber washer | |

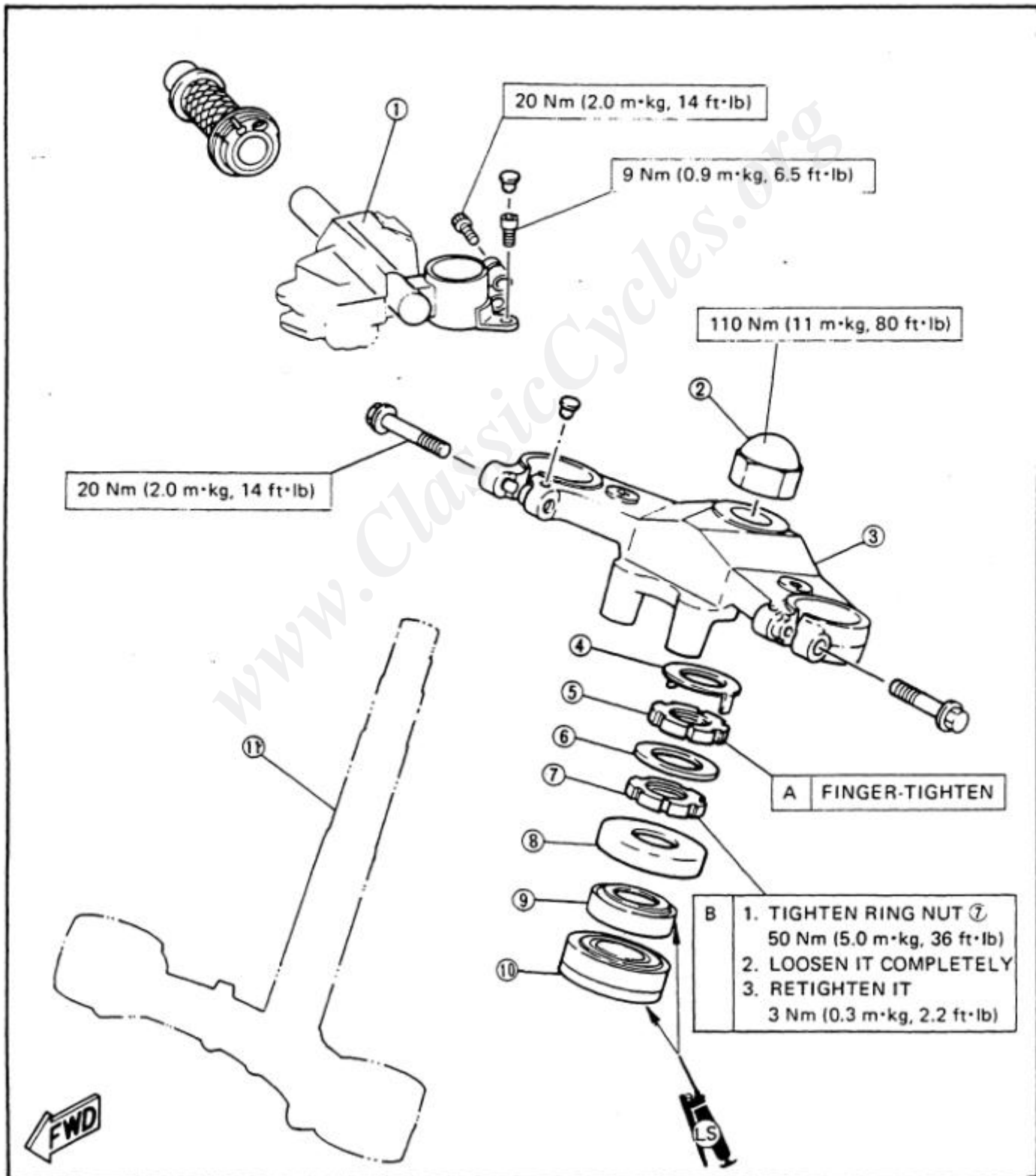

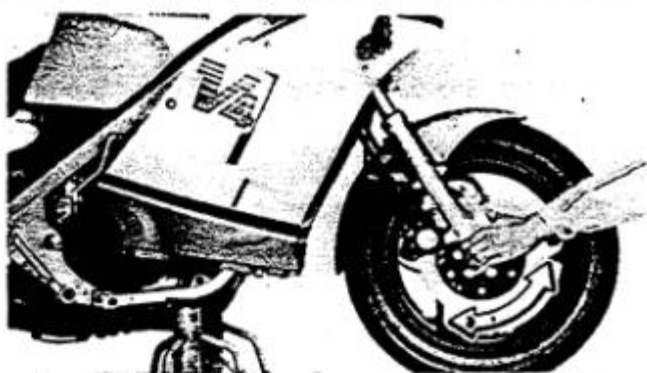

Steering Head Inspection

1. Remove:
 - Lower cowling
2. Check:
 - Steering assembly bearings

Grasp the bottom of the forks and gently rock the fork assembly **back** and forth.

Looseness → Adjust.

Adjustment

Steering Head Adjustment Steps:

- Remove the fork and bolt caps ①.
- Loosen the pinch bolts ②.
- Remove the handlebar securing bolts ③.
- Remove the handlebars ④.
- Remove the steering stem nut ⑤.
- Remove the steering crown ⑥.
- Remove the lock washer ⑦.
- Loosen the ring nut ⑧ and washer ⑨.
- Tighten the ring nut ⑩.



Ring Nut (Lower):
50 Nm (5.0 m·kg, 36 ft·lb)

NOTE:

The taper side of ring nuts must face downward.

- Check the steering stem by turning it lock to lock. If there is any binding, remove the steering stem assembly and inspect the steering bearings ⑪.
(See CHAPTER 6, STEERING HEAD for more details.)
- Loosen the ring nut ⑩ completely and retighten it to specification.



Ring Nut (Lower):
3 Nm (0.3 m·kg, 2.2 ft·lb)

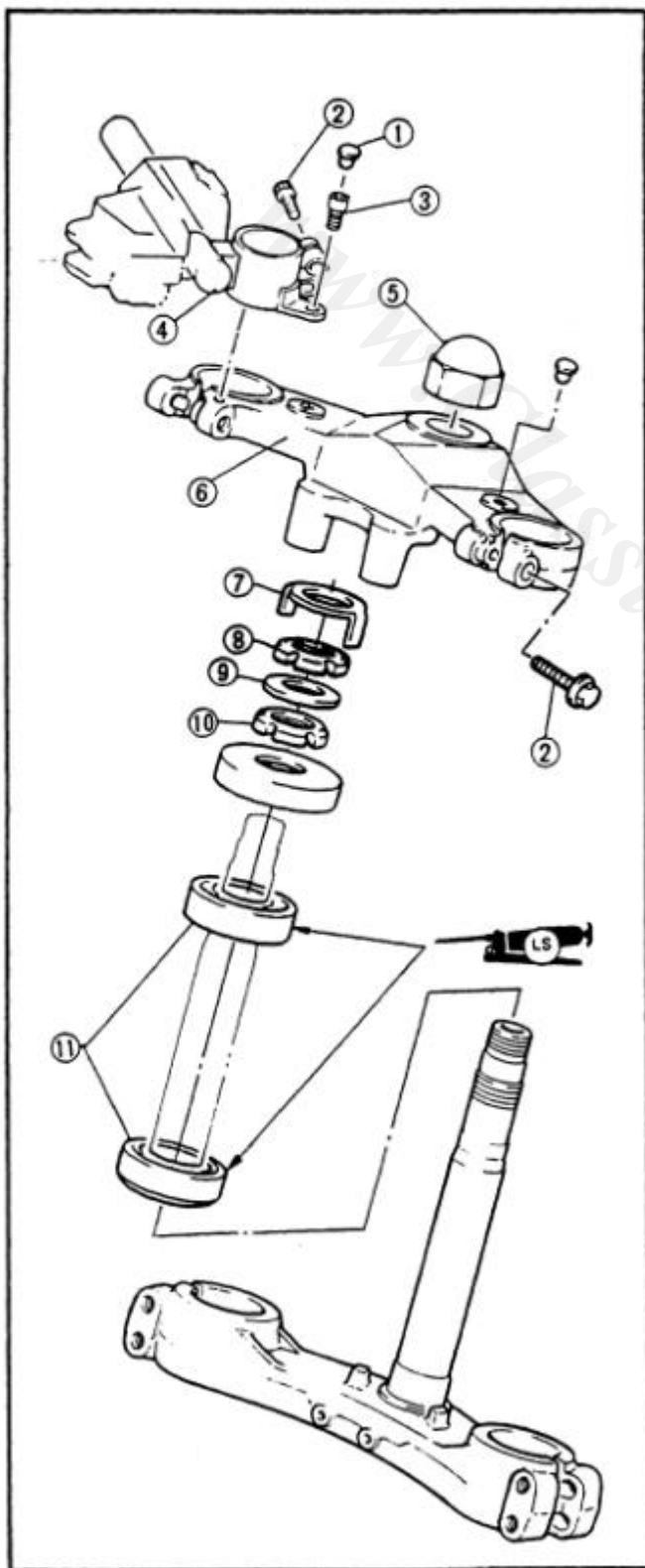



STEERING HEAD ADJUSTMENT



- Install the washer ⑨ .
- Install the ring nut ⑧ and hand-tighten, then align the slots of both ring nuts. If not aligned, hold the lower ring nut ⑩ and tighten the other until they are aligned.
- Install the lock washer ⑦ .

NOTE:
Make sure the lock washer tab is placed in the slots.

- Install the steering crown ⑥ and tighten the steering stem nut ⑤ to specification.



Steering Stem Nut:
110 Nm (11.0 m·kg, 80 ft·lb)

- Install the handlebars ④ and torque the bolts ③ to specification.



Pinch Bolt:
20 Nm (2.0 m·kg, 14 ft·lb)
Handlebar Bolt:
9 Nm (0.9 m·kg, 6.5 ft·lb)

- Install the forks and bolt caps ① .

www.Classic...

WHEEL BEARINGS

Front Wheel

1. Collar
2. Oil seal
3. Bearing
4. Spacer
5. Spacer flange
6. Meter clutch
7. Clutch retainer
8. Gear unit
9. Washer

Basic weight: With oil and full fuel tank	199 kg (439 lb) 205 kg (452 lb) (G)	
Maximum load *	211 kg (465 lb) 205 kg (452 lb) (G)	
Cold tire pressure	Front	Rear
Up to 90 kg (198 lb) load *	196 kPa (2.0 kg/cm ² , 28 psi)	226 kPa (2.3 kg/cm ² , 32 psi)
90 kg (198 lb) ~ Maximum load *	226 kPa (2.3 kg/cm ² , 32 psi)	284 kPa (2.9 kg/cm ² , 42 psi)
High speed riding	226 kPa (2.3 kg/cm ² , 32 psi)	245 kPa (2.5 kg/cm ² , 36 psi)

* Load is the total weight of cargo, rider, passenger, and accessories.

(G): For Germany

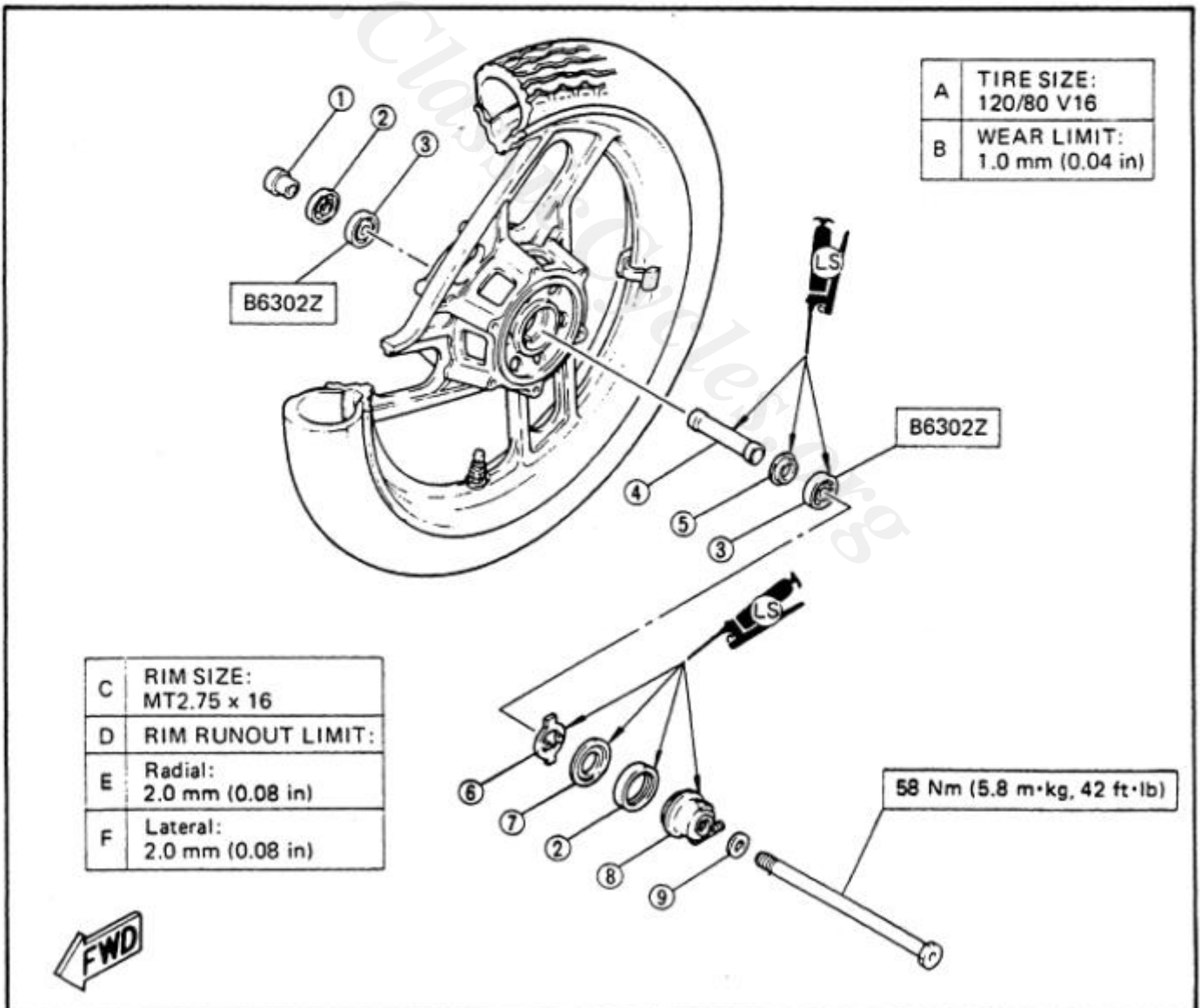



Rear Wheel

1. Rear axle
2. Drive chain puller
3. Collar
4. Oil seal
5. Bearing
6. Spacer flange
7. Spacer
8. O-ring
9. Damper
10. Clutch hub
11. Driven sprocket (38T)

TIRE SIZE: 130/80 V18
WEAR LIMIT: 1.0 mm (0.04 in)
RIM RUNOUT LIMIT:
Radial: 2.0 mm (0.08 in)
Lateral: 2.0 mm (0.08 in)

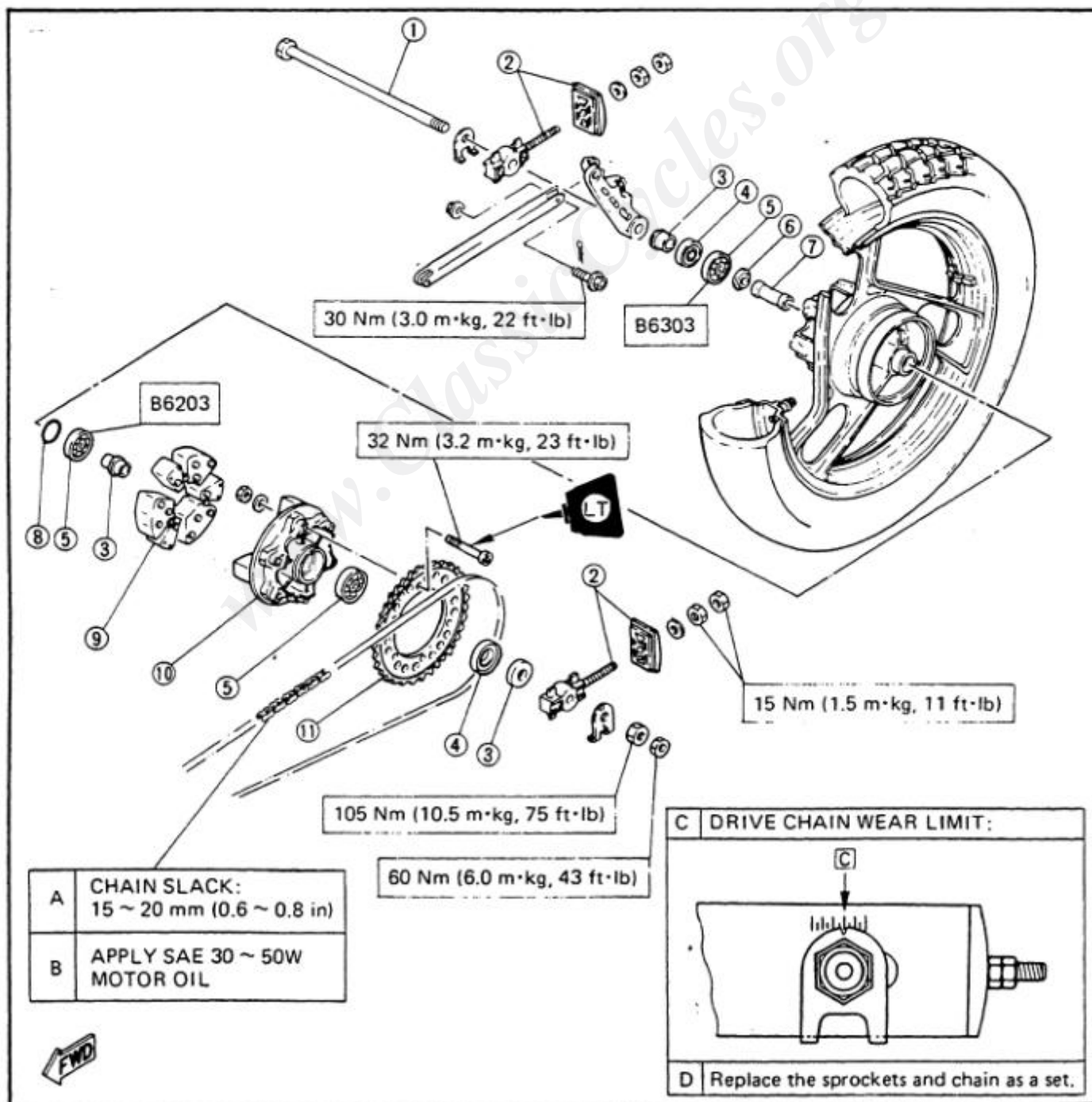

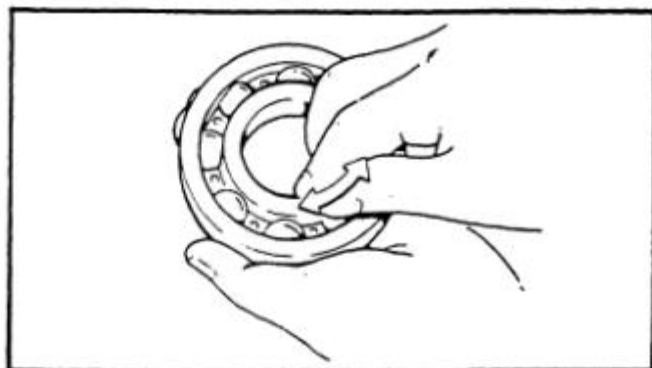

Front Wheel Bearings

1. Raise the front end of the motorcycle, and spin the wheel by hand. Touch the axle or front fork while spinning the wheel.

Excessive vibration → Replace bearings.

Rear Wheel Bearings

1. Remove:
 - Rear wheel
2. Check:
 - Bearing movement

Rotate with the fingers.

Roughness/Wear → Replace.

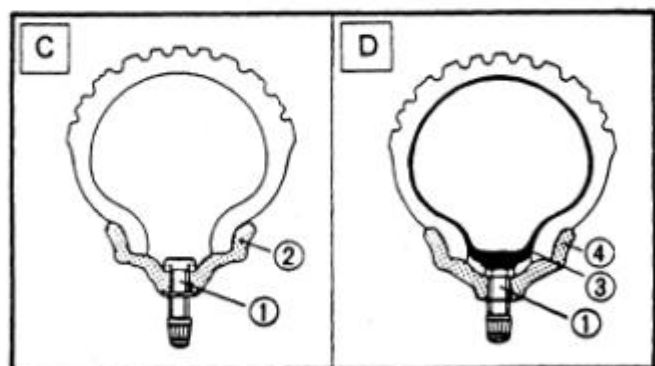
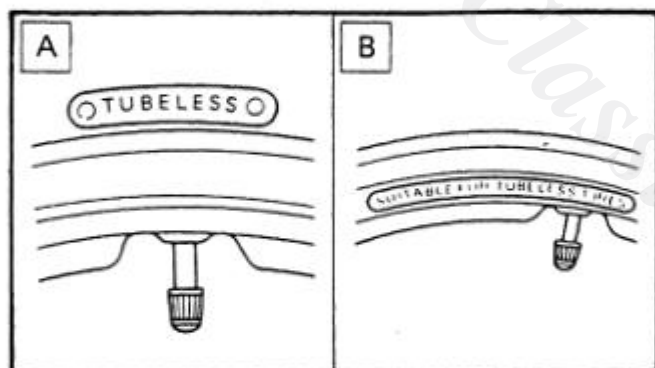

TUBELESS TIRES AND ALUMINUM WHEELS

WARNING:

Do not attempt to use tubeless tires on a wheel designed for tube type tires only. Tire failure and personal injury may result from sudden deflation.

Wheel	Tire
Tube type	Tube type only
Tubeless	Tube type or tubeless

Be sure to install the correct tube when using tube type tires.

- [A] Tire
- [B] Wheel
- [C] Tubeless tire
- [D] Tube type tire
- 1 Air valve
- 2 Aluminum wheel (tubeless type)
- 3 Tube
- 4 Aluminum wheel (tube type)

NOTE:

Germany and Austria: It is not allowed to use tube-type tires on motorcycle originally equipped with tubeless tires.

WARNING:

This motorcycle is fitted with "V" range tires (for super high speed running). The following points must be observed in order for you to make fully effective use of these tires.



1. Never fail to use "V" range tires in tire replacement. "S" or "H" tires may be in danger of bursting at super high-speeds.
2. New tires have a relatively poor adhesion on the road surface so do not allow them to be subjected to high speed load from maximum speed until after a break-in run of approx. 10 km (60 mi).
3. Before any high-speed runs, remember to allow a sufficient warm-up time for the tires.
4. Always use the correct tire inflation pressure according to the operating conditions.

A	Basic weight: With oil and full fuel tank	199 kg (439 lb) 205 kg (452 lb) (G)	
B	Maximum load*	211 kg (465 lb) 205 kg (452 lb) (G)	
C	Cold tire pressure	Front	Rear
D	Up to 90 kg (198 lb) load*	196 kPa (2.0 kg/cm ² , 28 psi)	226 kPa (2.3 kg/cm ² , 32 psi)
E	90 kg (198 lb) ~ Maximum load*	226 kPa (2.3 kg/cm ² , 32 psi)	284 kPa (2.9 kg/cm ² , 42 psi)
F	High speed riding	226 kPa (2.3 kg/cm ² , 32 psi)	245 kPa (2.5 kg/cm ² , 36 psi)

* Load is the total weight of cargo, rider, passenger, and accessories.

(G): For Germany

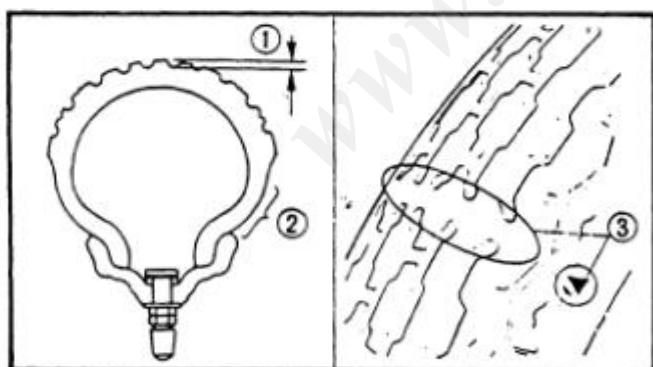

Always perform the following steps to ensure safe operation, maximum tire performance, and long service.

1. Measure:
 - Tire pressure
 - Out of specification → Adjust.
 2. Inspect:
 - Tire surfaces
 - Wear/Damage → Replace.
- 

**Minimum Tire Tread Depth:
(Front and Rear)
1.0 mm (0.04 in)**
- 1 Tread depth
 - 2 Side wall
 - 3 Wear indicator
3. Inspect:
 - Aluminum wheels
 - Damage/Bends → Replace.
 - Never attempt even small repairs to the wheel.



NOTE: _____
Always balance the wheel when a tire or wheel has been changed or replaced.

WARNING: _____

Ride conservatively after installing a tire to allow it to seat itself properly on the rim.

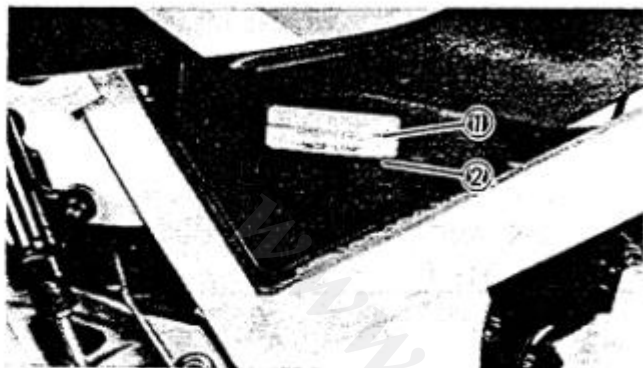

**ELECTRICAL
BATTERY**

1. Check:
 - Fluid level
Incorrect → Refill,
Fluid level should be between upper and lower level marks.

- 1 Upper level
- 2 Lower level

CAUTION: _____

Refill with distilled water only; tap water contains minerals harmful to a battery.

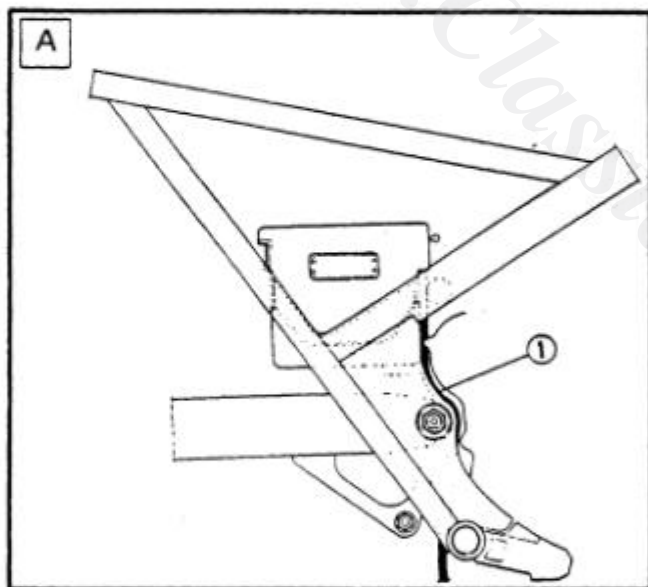

2. Connect:
 - Breather hose
Be sure the hose is properly attached and routed.
3. Inspect:
 - Breather hose
Obstruction → Remove.
Damage → Replace.

A HOW TO ROUTE BATTERY BREATHER HOSE
1 Breather hose

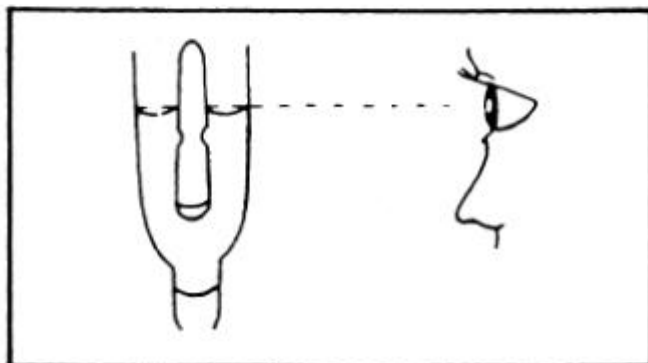

CAUTION: _____

Always charge a new battery before using it to ensure maximum performance.

<p>Charging Current: 0.55 amps/10 hrs Specific Gravity: 1.280 at 20°C (68° F)</p>



WARNING:

Battery electrolyte is dangerous; it contains sulfuric acid and therefore is poisonous and highly caustic.

Always follow these preventive measures:

- Avoid bodily contact with electrolyte as it can cause severe burns or permanent eye injury.
- Wear protective eye gear when handling or working near batteries.

Antidote (EXTERNAL):

- SKIN – Flush with water.
- EYES – Flush with water for 15 minutes and get immediate medical attention.

Antidote (INTERNAL):

- Drink large quantities of water or milk follow with milk of magnesia beaten egg, or vegetable oil. Get immediate medical attention.

Batteries also generate explosive hydrogen gas, therefore you should always follow these preventive measures:

- Charge batteries in a well-ventilated area.
- Keep batteries away from fire, sparks, or open flames (e.g., welding equipment, lighted cigarettes, etc.)
- DO NOT SMOKE when charging or handling batteries.

KEEP BATTERIES AND ELECTROLYTE OUT OF REACH OF CHILDREN.

HEADLIGHT

Headlight Bulb Replacement

1. Remove:
 - Meter assembly

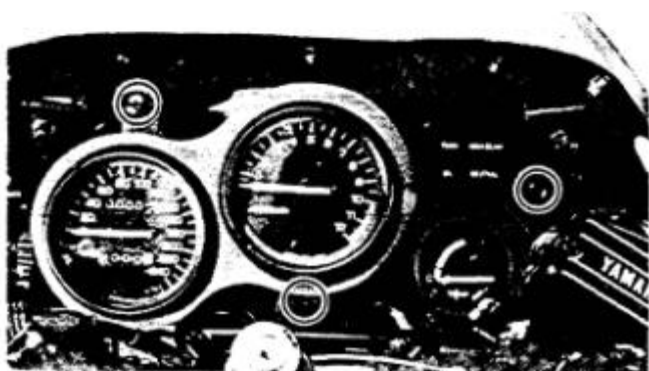

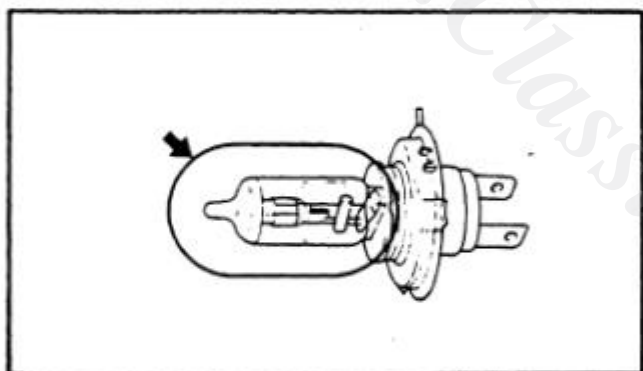

2. Disconnect:
 - Headlight connector ①
3. Remove:
 - Cover ②

4. Remove:
 - Bulb ①

WARNING:

Do not touch headlight bulb when it is on as the bulb generates enormous heat; keep flammable objects away.

5. Install:
 - Bulb (New)

CAUTION:

Avoid touching glass part of bulb. Also keep it free from oil otherwise, transparency of glass, bulb life and illuminous flux will be adversely affected. If oil gets on bulb, clean it with a cloth moistened thoroughly with alcohol or lacquer thinner.

6. Install:
 - Cover
7. Connect:
 - Headlight connector
8. Adjust:
 - Headlight

Headlight Adjustment

1. Adjust:
 - Headlight (Horizontally)

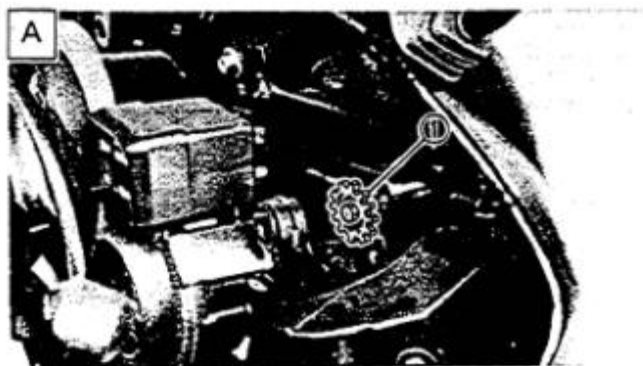

A Horizontal Adjustment	
Right	Turn adjusting knob ① clockwise
Left	Turn adjusting knob ① counterclockwise



2. Adjust:
 - Headlight (Vertically)

B Vertical adjustment	
Higher	Turn the adjusting knob ① counterclockwise
Lower	Turn the adjusting knob ① clockwise

3. Install:
 - Meter assembly

TAILLIGHT

Taillight Bulb(s) Replacement

1. Remove:
 - Seat
 - Tool kit
 - Tool box ①
2. Remove:
 - Bulbs

Turn the bulb counterclockwise and remove.
3. Install:
 - Bulbs (New)
4. Connect:
 - Taillight connector
5. Install:
 - Tool box
 - Tool kit
 - Seat

FUSE

There are two fuse blocks on this motorcycle. The main fuse block is located at the right side of the battery **A**. The other fuse block is located behind the engine temperature gauge **B**.

1. Inspect
 - Fuses

Defective → Replace.
Blown fuse (new) → Inspect circuit.

NOTE: _____
Install new fuses of proper amperage.

① Spare fuse



Description	Amperage	Quantity
Main	20A	1
Headlight	15A	1
YPVS	10A	1
Signal	10A	1
Reserve	15A	1

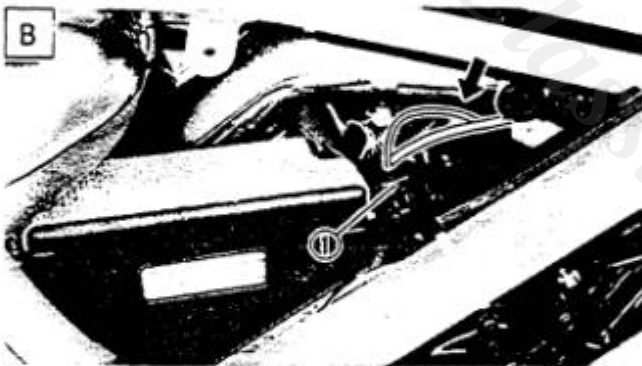
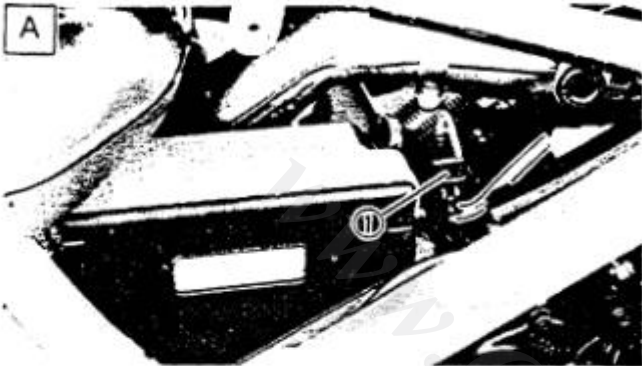

2. Install:
- Fuse holder ①

A CORRECT

B INCORRECT

CHAPTER 3 ENGINE OVERHAUL

ENGINE REMOVAL	3-1
PREPARATION FOR REMOVAL	3-1
COWLING	3-3
BATTERY	3-5
AIR FILTER	3-5
RADIATOR	3-7
CARBURETOR (LEFT)	3-9
MUFFLER	3-9
CONNECTOR AND CABLE	3-11
CRANKCASE COVER (LEFT) AND DRIVE CHAIN	3-13
ENGINE REMOVAL	3-15
ENGINE DISASSEMBLY	3-15
CARBURETOR (RIGHT)	3-15
CYLINDER HEAD	3-17
CARBURETOR JOINT AND REED VALVE (UPPER)	3-17
CYLINDER AND PISTON (UPPER)	3-19
WATER JACKET AND REED VALVE (LOWER)	3-19
CYLINDER AND PISTON (LOWER)	3-19
OIL PUMP (ENGINE OIL) AND FLYWHEEL	3-21
WATER PUMP AND CRANKCASE COVER (RIGHT)	3-23
CLUTCH AND KICK GEAR	3-25
PRIMARY GEAR AND CHANGE SHAFT	3-27
OIL PUMP (TRANSMISSION OIL)	3-27
TRANSMISSION	3-29
CRANKCASE, CRANKSHAFT, AND BALANCER SHAFT	3-31
INSPECTION AND REPAIR	3-33
CYLINDER HEAD	3-33
CYLINDER	3-33
YPVS (YAMAHA POWER VALVE SYSTEM)	3-35
PISTON, PISTON RING, PISTON PIN, AND CONNECTING ROD BEARING	3-37
CRANKSHAFT	3-41
BALANCER SHAFT	3-43
REED VALVE AND CARBURETOR JOINT	3-43
CLUTCH	3-45



OIL PUMP (ENGINE OIL) AND DELIVERY PIPE	3-49
OIL PUMP (TRANSMISSION OIL)	3-49
PRIMARY GEARS	3-51
TRANSMISSION	3-53
KICK STARTER	3-55
WATER JACKET	3-57
BEARINGS	3-57
OIL SEALS AND BLIND SEALS	3-59
CIRCLIPS AND WASHERS	3-59
ENGINE ASSEMBLY AND ADJUSTMENT	3-61
CRANKCASE ASSEMBLY	3-61
TRANSMISSION	3-69
OIL PUMP (TRANSMISSION OIL)	3-73
PRIMARY GEAR AND CHANGE SHAFT	3-75
KICK GEAR AND PUMP GEAR	3-79
CLUTCH	3-81
CRANKCASE COVER AND WATER PUMP	3-85
OIL PUMP (ENGINE OIL) AND FLYWHEEL	3-87
CYLINDER HEAD, CYLINDER, AND YPVS	3-91
PISTON AND CYLINDER (LOWER)	3-93
REED VALVE AND WATER JACKET (LOWER)	3-95
PISTON AND CYLINDER (UPPER)	3-95
YPVS LINK AND REED VALVE (UPPER)	3-97
CYLINDER HEAD AND CARBURETOR (RIGHT)	3-99
REMOUNTING ENGINE	3-103
DRIVE CHAIN AND CRANKCASE COVER (LEFT)	3-105
CONNECTOR AND CABLE	3-105
MUFFLER	3-107
CARBURETOR (LEFT)	3-109
RADIATOR	3-109
AIR FILTER	3-111
BATTERY AND COWLING	3-111



ENGINE OVERHAUL

ENGINE REMOVAL

NOTE:

It is not necessary to remove the engine in order to remove the following components:

- Piston
- Clutch
- Carburetor

PREPARATION FOR REMOVAL

1. Remove all dirt, mud, dust, and foreign material before removal and disassembly.

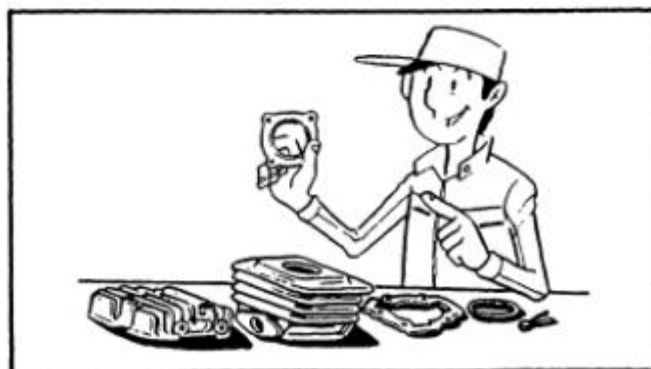
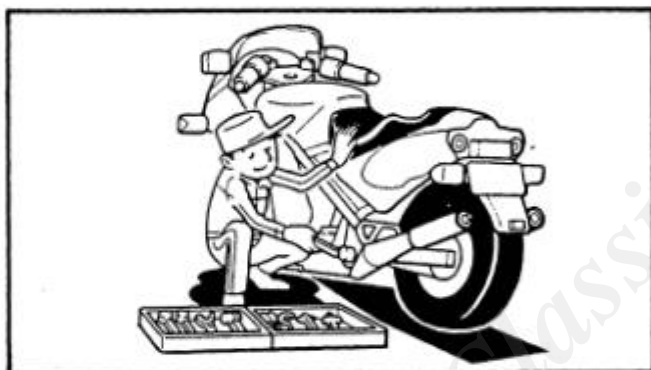
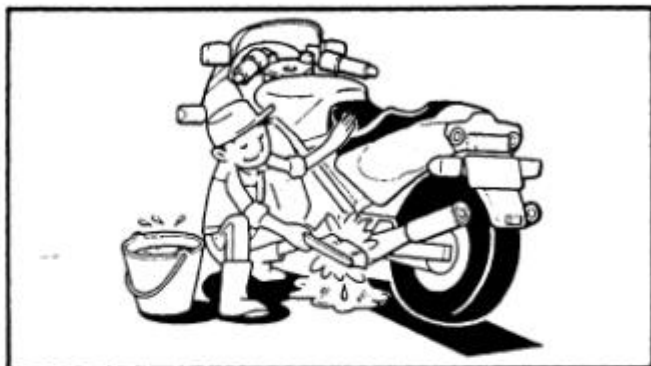

2. Use proper tools and cleaning equipment. Refer to CHAPTER 1, "SPECIAL TOOL."

NOTE:

When disassembling the engine, keep mated parts together. This includes gears, cylinders, pistons, and other parts that have been "mated" through normal wear. Mated parts must be reused as an assembly or replaced.

3. During the engine disassembly, clean all parts and place them in trays in the order of disassembly. This will speed up assembly time and help assure that all parts are correctly reinstalled in the engine.

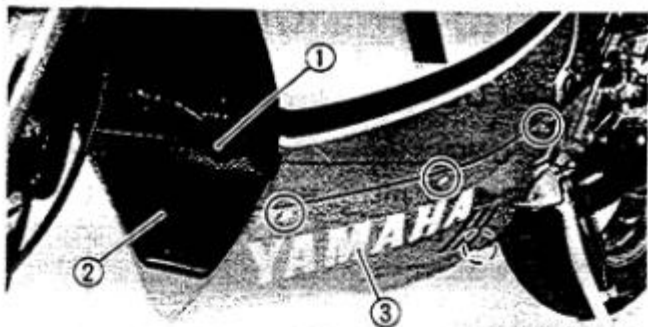

COWLING

1. Remove:
 - Engine grille holder stay ①
 - Engine grille ②
 - Lower cowling ③
 Refer to CHAPTER 2, "COWLING".

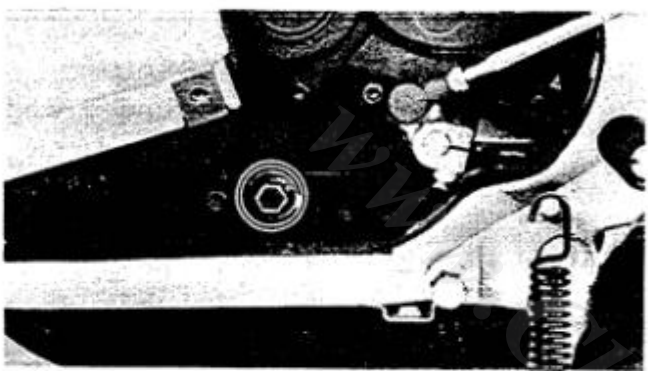

2. Drain:
 - Transmission oil
3. Remove:
 - Radiator cap

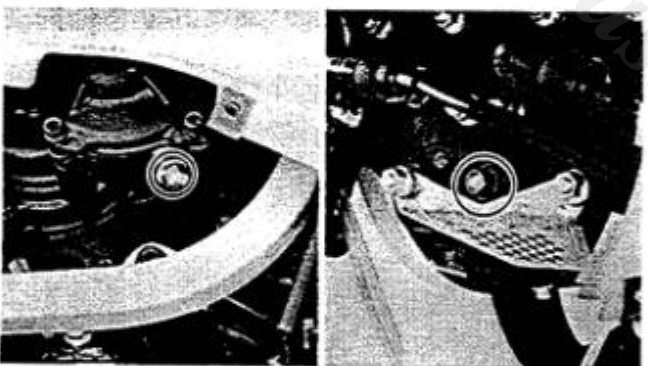

4. Drain:
 - Coolant



5. Remove:
 - Center cowling ① (Left and right)
 Refer to CHAPTER 2, "COWLING".

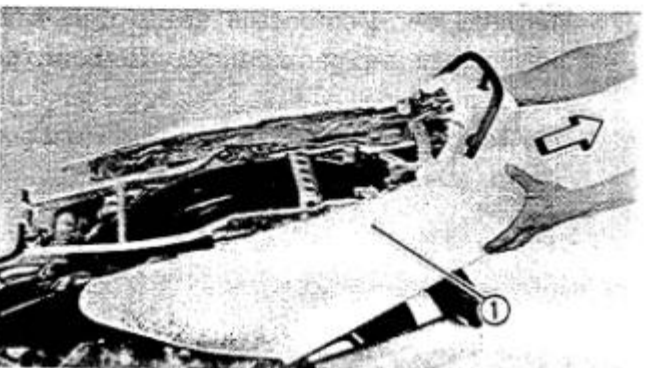

6. Remove:
 - Rear cowling assembly ①
 Refer to CHAPTER 2, "COWLING".

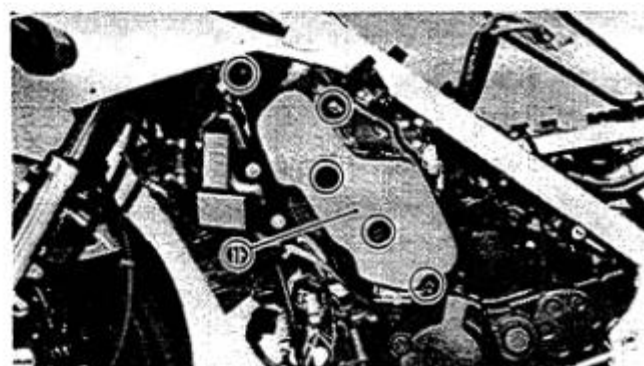
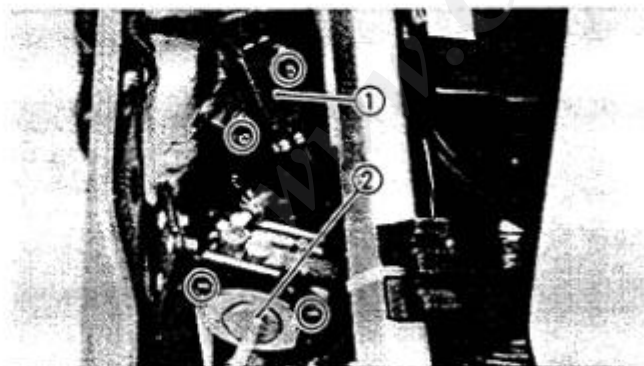
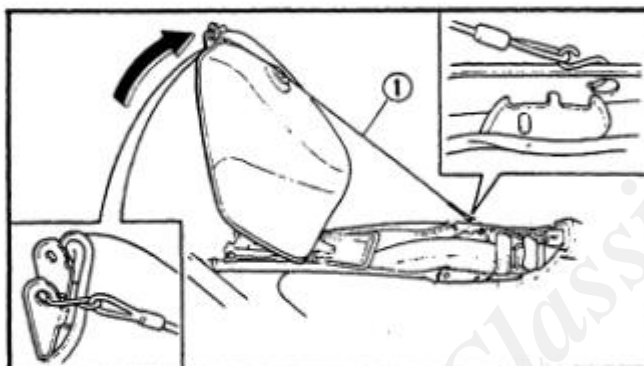
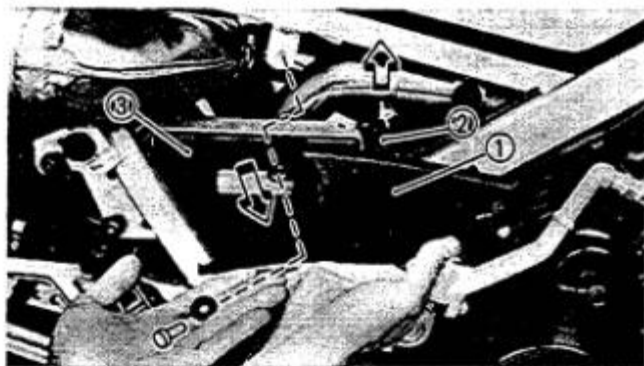
**BATTERY**

1. Remove:
 - Side cover ①
 - Fuse holder ②
 - Battery cover ③

2. Disconnect:
 - Battery leads

NOTE:

Disconnect the negative lead first.

3. Remove:
 - Battery

AIR FILTER

1. Remove:
 - Bolt (Fuel tank)
2. Pull up the fuel tank. Use the fuel tank holding wire as shown.

NOTE:

The fuel tank holding wire ① can be found in the owners tool kit.

3. Remove:
 - Choke lever ①
 - Fuel cock ②

4. Remove:
 - Air duct (Left) ①

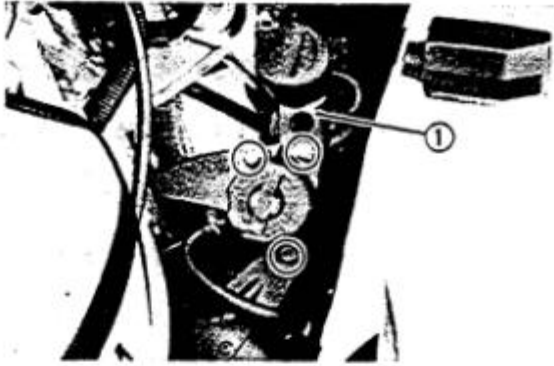

5. Remove:
 - Cap retainer ①
 - Bolt (Hose holder)

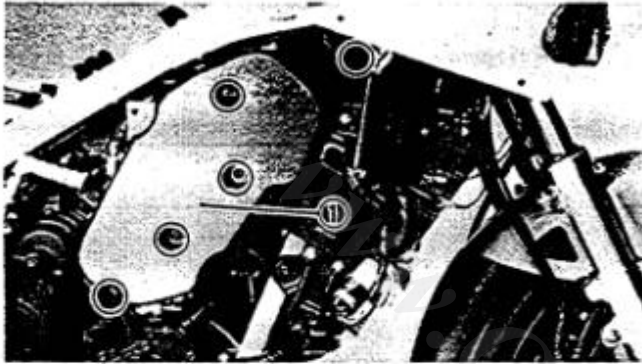

6. Remove:
 - Air duct (Right) ①

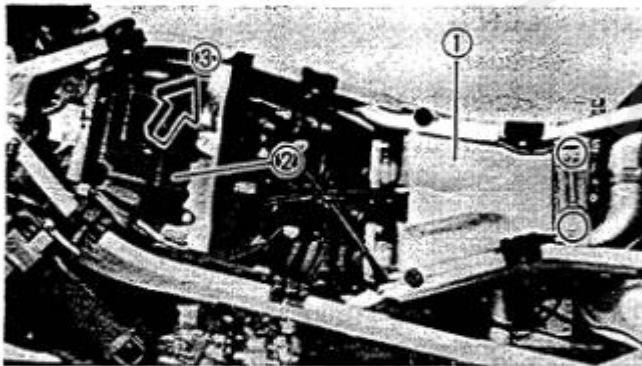

7. Remove:
 - Heat protector ①
 - Air filter box ②

③ Pull out

RADIATOR

1. Disconnect:
 - Electric fan motor lead
 - Engine oil hose ①

NOTE: _____
 Plug the hose nozzle so oil will not run out of oil tank.

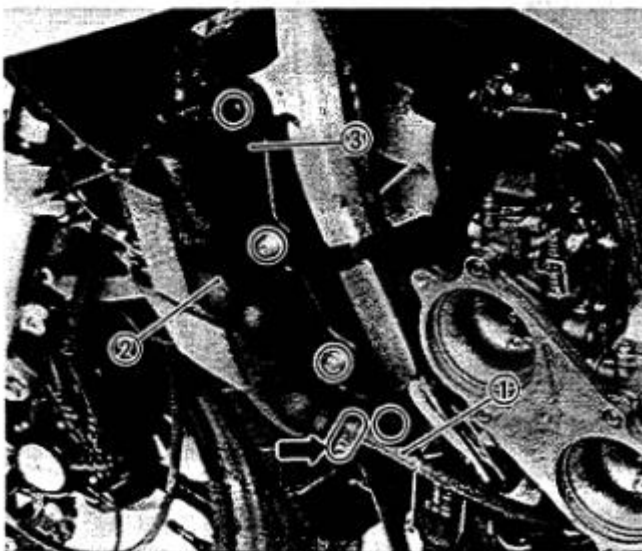

2. Remove:
 - Screws (Sub oil tank ②)
 - Bolts (Radiator mount)
 - Stay ③
3. Remove:
 - Bolts (Radiator mount)

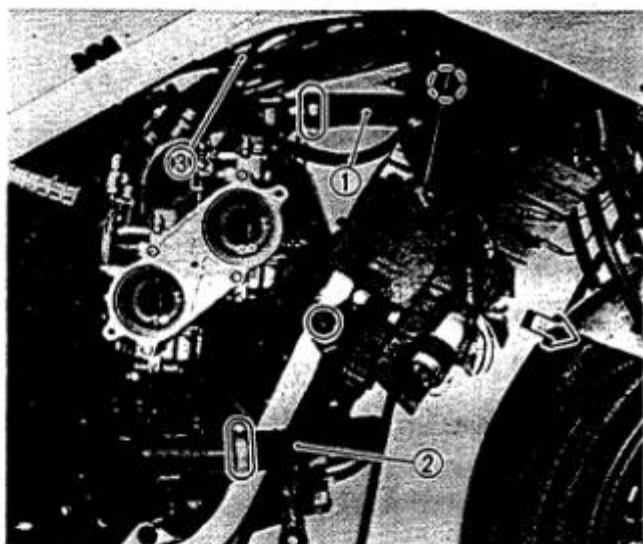

4. Disconnect:
 - Radiator hose (Inlet) ①
 - Radiator hose (Outlet) ②
 - Bypass hoses ③
5. Remove:
 - Radiator

CAUTION:

Do not bend or damage any of the radiator fins when removing the radiator from the motorcycle or when storing it.

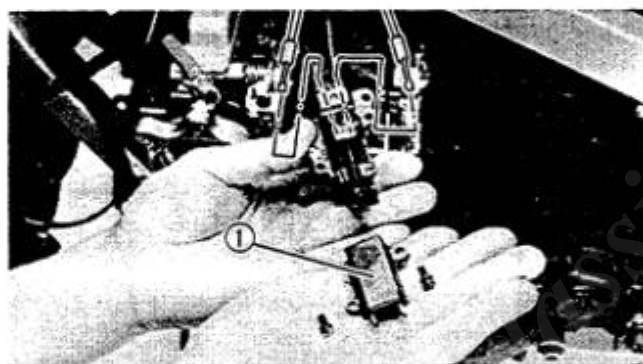
**CARBURETOR (LEFT)**

1. Remove:
 - Screws (Choke lever cover ①)
2. Disconnect:
 - Choke cables (Two cables)
 - Throttle cables
3. Disconnect:
 - Fuel hose ②
4. Loosen:
 - Clamp screws ③
5. Remove:
 - Carburetors (Left)

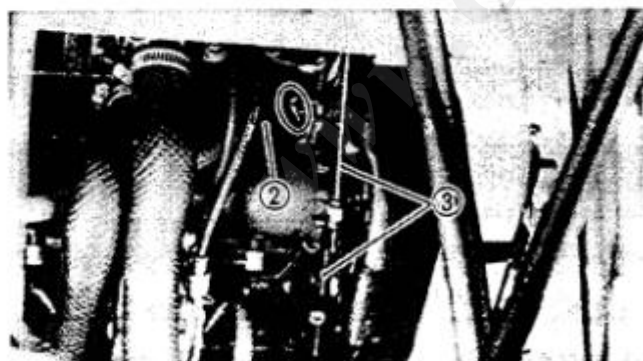
**NOTE:**

After removing the carburetors, cover the carburetors with a clean cloth to keep dust and dirt out.

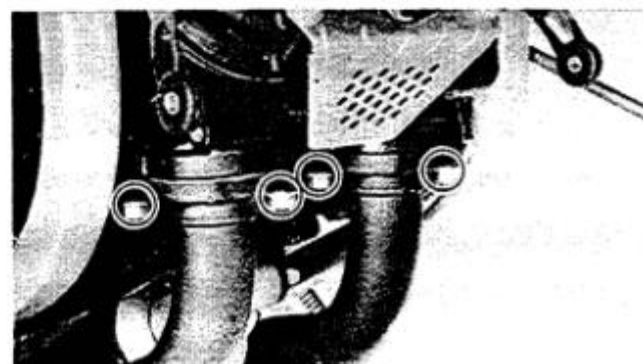
**MUFFLER**

1. Remove:
 - Nuts (Lower cylinders)

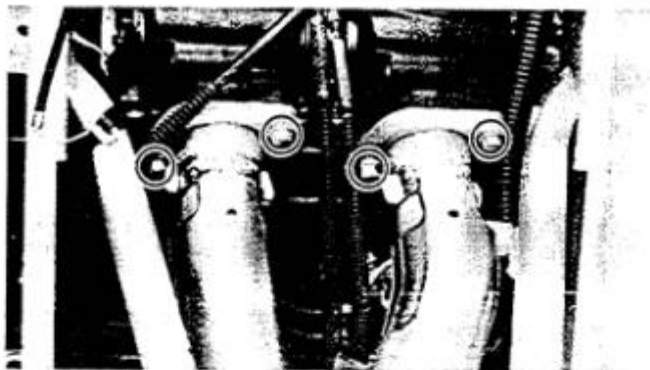

2. Remove:
 - Bolts
 - Nuts (Upper cylinders)

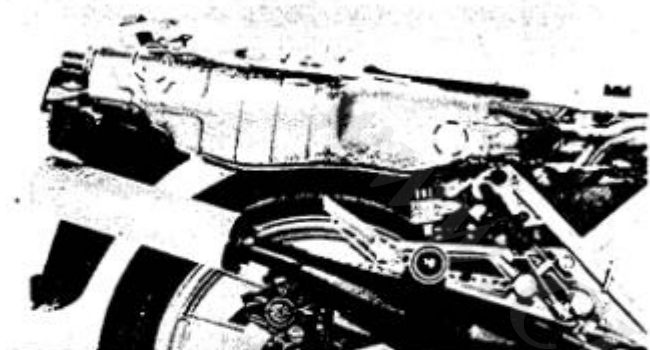

3. Remove:
 - Muffler mount bolts
 - Mufflers

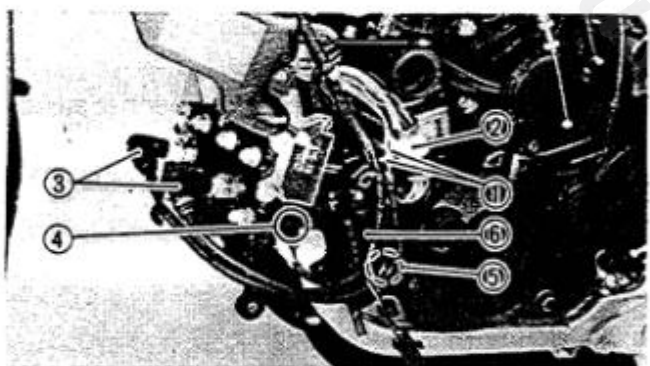

CONNECTOR AND CABLE

1. Disconnect:
 - Pickup coil lead ①
 - Generator lead ②
 - Spark plug lead ③ (Lower)
 - Rectifier/regulator lead ④
 - Ignition coil lead ⑤
2. Remove:
 - Ignition coil (Lower cylinder) ⑥
3. Disconnect:
 - Thermo unit lead ①
 - Thermo switch lead ②
 - Spark plug lead ③ (Upper)
 - Throttle cable ④
4. Remove:
 - Clamp ⑤
 - Thermostat housing assembly ⑥
5. Loosen:
 - YPVS cable adjusters ①

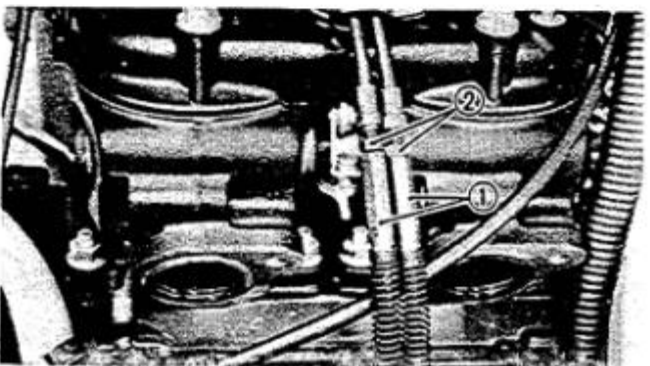
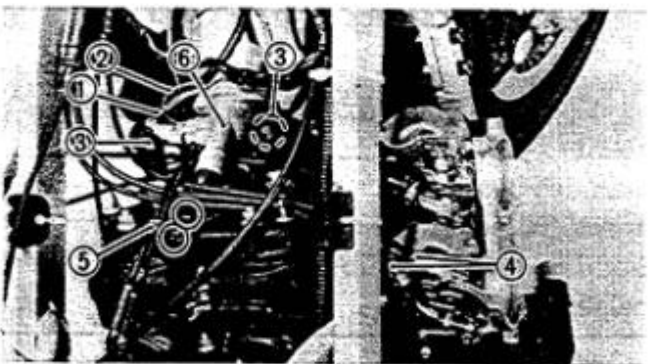

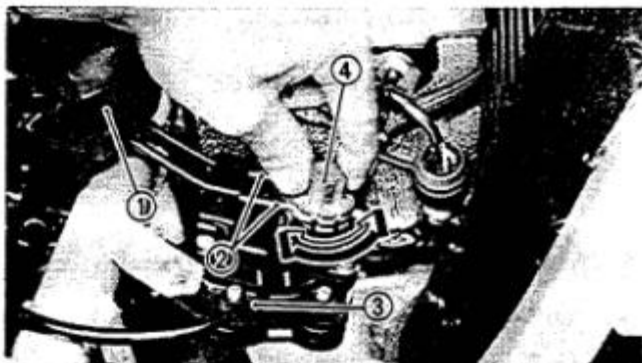

6. Uncover the servomotor cover ①.
7. Disconnect:
 - YPVS cables ②
 - Oil pump cable ③

NOTE:

Disconnect the cables by turning the servomotor pulley ④.

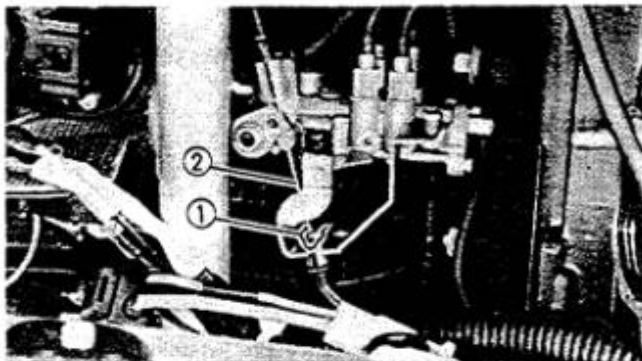

8. Remove:
 - Circlip ①
9. Disconnect:
 - Oil pump cable ②

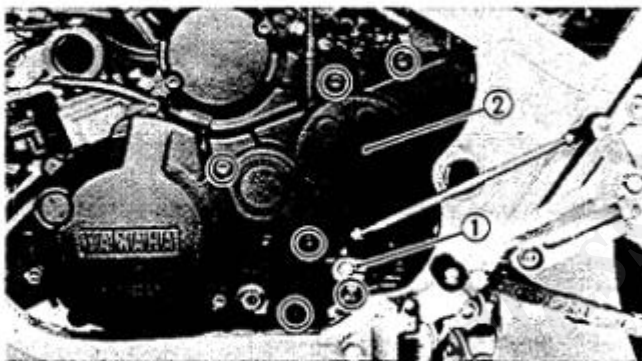
**CRANKCASE COVER (LEFT) AND DRIVE CHAIN**

1. Remove
 - Change pedal arm securing bolt
2. Disconnect:
 - Change pedal arm ①
3. Remove:
 - Crankcase cover (Left) ②
 - Dowel pins
4. Bend:
 - Lock washer tab
5. Remove:
 - Drive sprocket securing nut ③
 - Lock washer ④
 - Drive sprocket ⑤ with drive chain ⑥

NOTE:

If it is difficult to remove the drive sprocket, loosen the axle nut and chain slack adjusting bolts, then push rear wheel toward the front.

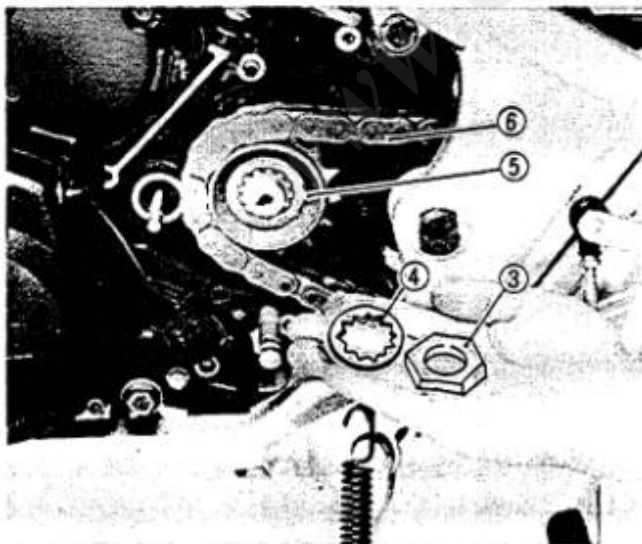

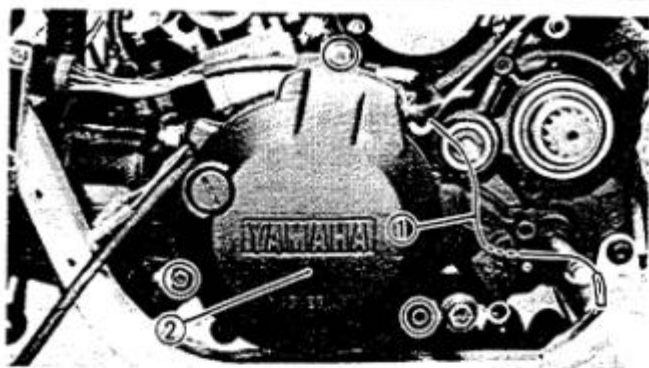

6. Disconnect:
 - Neutral switch lead ①
7. Remove:
 - Generator cover ②

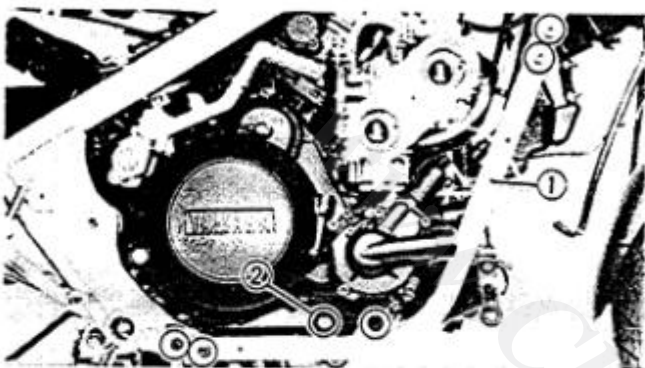

ENGINE REMOVAL

1. Remove:
 - Downtube frame ①
 - Tension rod mount bolt ②

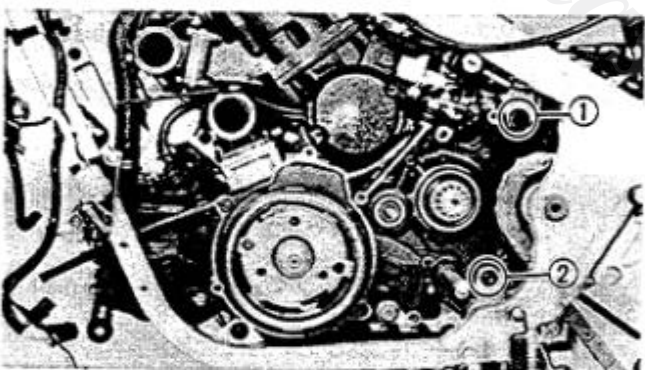

2. Remove:
 - Engine mount (Rear upper) ①
 - Engine mount (Rear lower) ②
 - Engine assembly

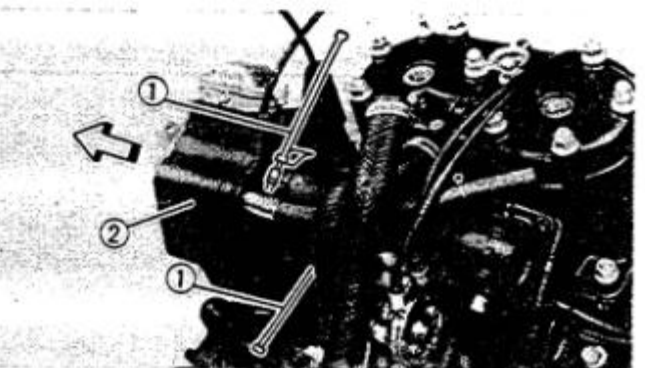
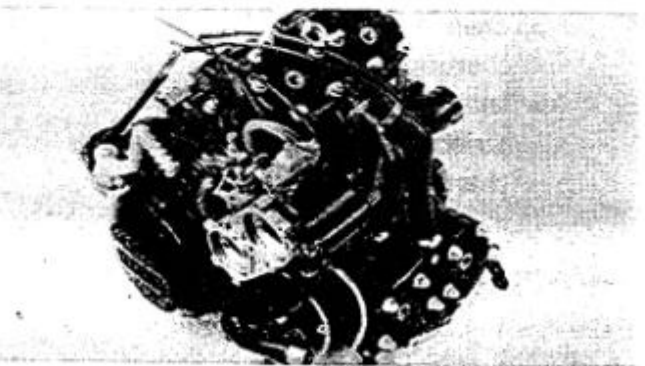

ENGINE DISASSEMBLY

CARBURETOR (RIGHT)

1. Loosen:
 - Clamp screws ①
2. Remove:
 - Carburetors (Right) ②
 - Clamps

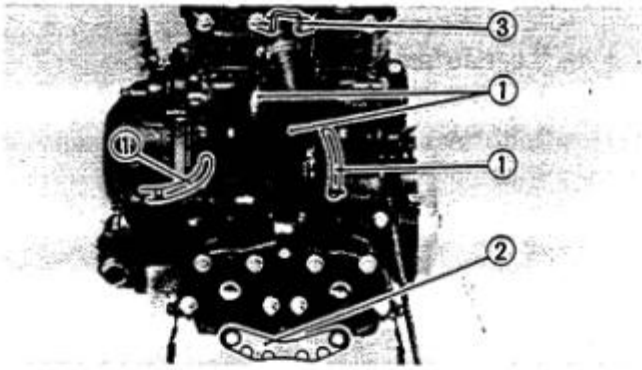
**CYLINDER HEAD**

1. Disconnect:
 - Hoses ①
2. Remove:
 - Cylinder head nuts
 - Washers
 - Engine guard ②
 - Stay ③
 - Cylinder heads
 - Cylinder head gaskets

NOTE: _____

- Remove the nuts starting with the highest numbered one.
- The embossed numbers in the cylinder head designate the cylinder head tightening sequence.

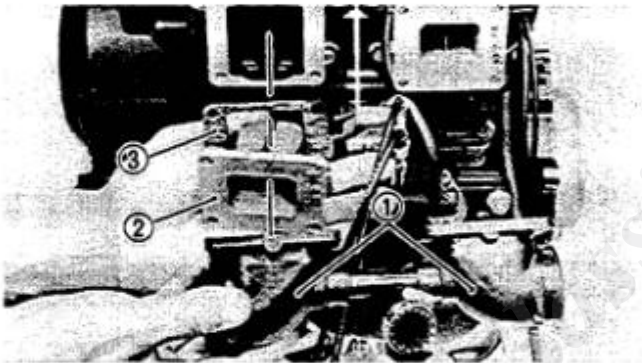
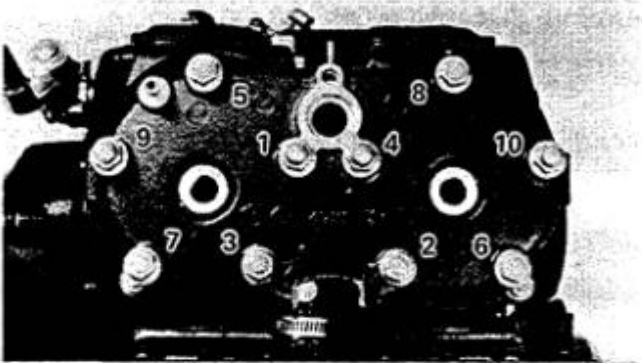
**CARBURETOR JOINT AND REED VALVE (UPPER)**

1. Remove:
 - Carburetor joints ①
2. Disconnect:
 - Engine oil delivery hoses

NOTE: _____

Do not lose the delivery hose clamps.

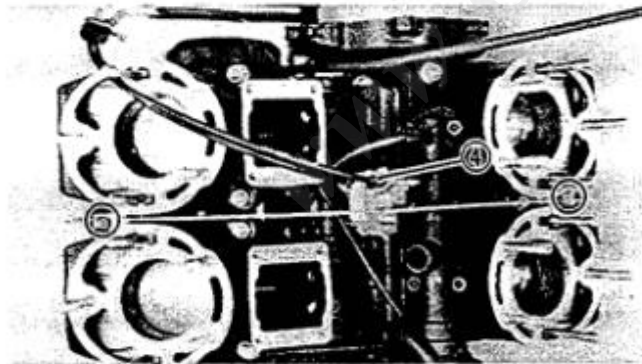

3. Remove:
 - Reed valves ②
 - Gaskets ③
4. Remove:
 - YPVS link assembly ④

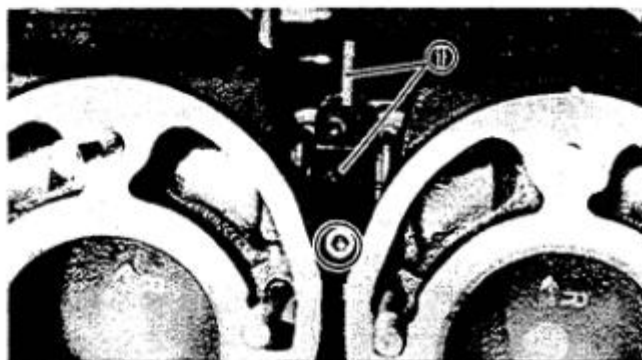

5. Remove:
 - YPVS joints ⑤

**CYLINDER AND PISTON (UPPER)**

1. Remove:
 - Cylinder nuts
 - Dowel pins
 - Cylinder gaskets
2. Mark each piston so it can be reinstalled in the appropriate cylinder.
3. Remove:
 - Piston pin clips ①

NOTE:

Before removing the piston pin clip, cover the crankcase with a clean rag so you will not accidentally drop the clip into the crankcase.

- Piston pins ②
- Pistons ③
- Connecting rod bearings ④

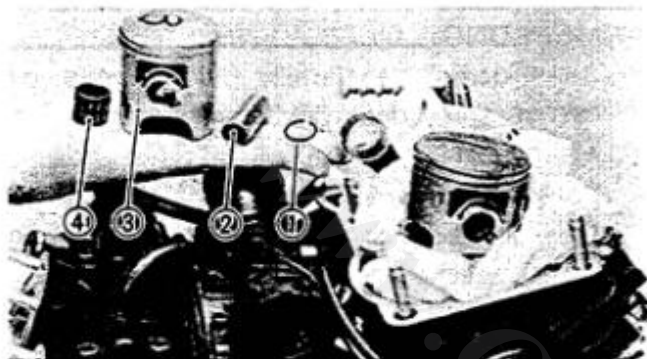
**WATER JACKET AND REED VALVES (LOWER)**

1. Remove:
 - Water jackets ①

NOTE:

Do not lose the O-rings ②.

2. Remove:
 - Carburetor joints ③
 - Reed valve ④
 - Gaskets ⑤
 - Housing ⑥
 - Gasket ⑦
3. Disconnect:
 - Engine oil delivery hoses

NOTE:

Do not lose the delivery hose clamps.

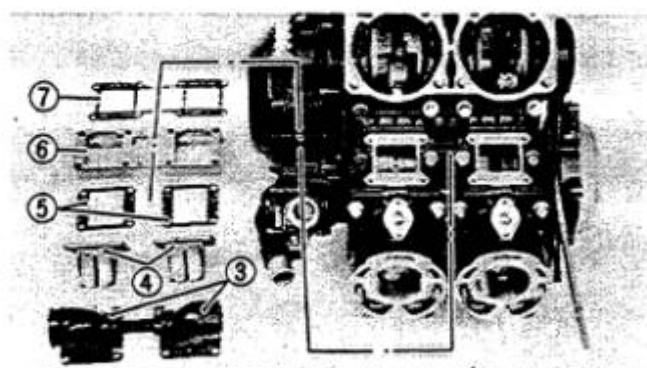
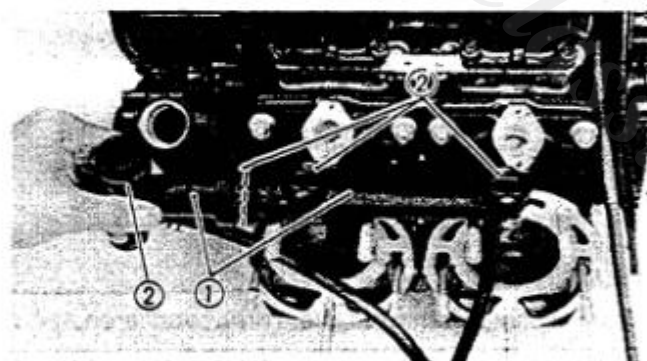
**CYLINDER AND PISTON (LOWER)**

1. Remove:
 - Cylinder nuts
 - Dowel pins
 - Cylinder gaskets
2. Mark each piston so it can be reinstalled in the appropriate cylinder.

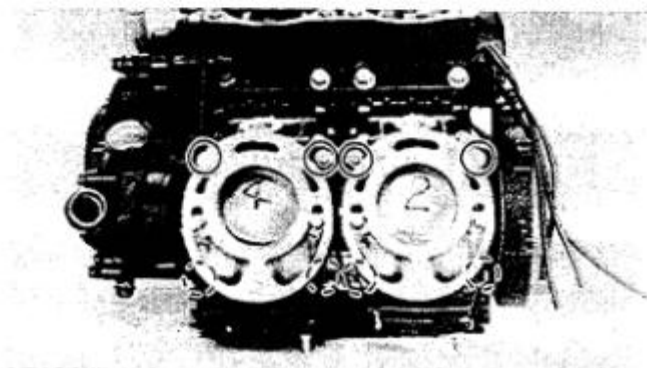

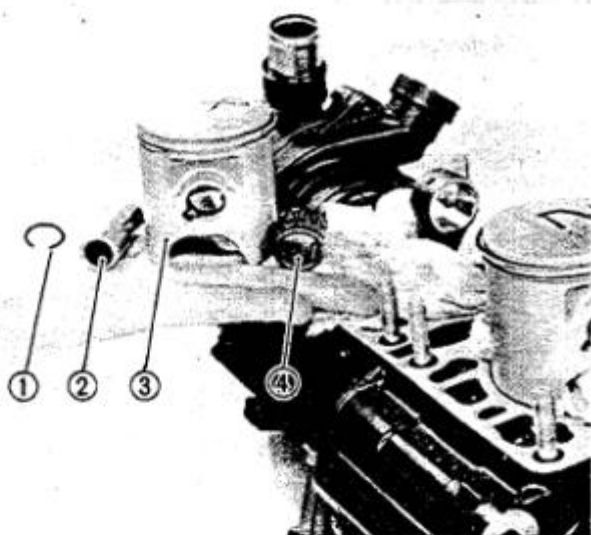

3. Remove:

- Piston pin clips ①

NOTE:

Before removing the piston pin clip, cover the crankcase with a clean rag so you will not accidentally drop the clip into the crankcase.

- Piston pins ②
- Pistons ③
- Connecting rod bearings ④

**OIL PUMP (ENGINE OIL) AND FLYWHEEL**

1. Remove:

- Crankshaft end cover ①
- Oil pump (Engine oil) ②

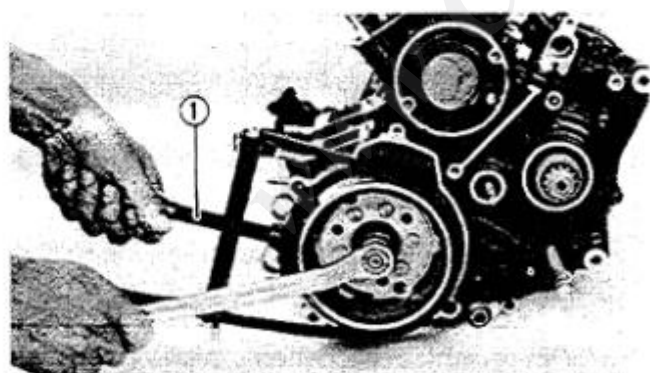

2. Attach:

- Universal Sheave Holder (90890-01701) ①

3. Loosen:

- Nut (Flywheel)

4. Remove:

- Nut
- Washers

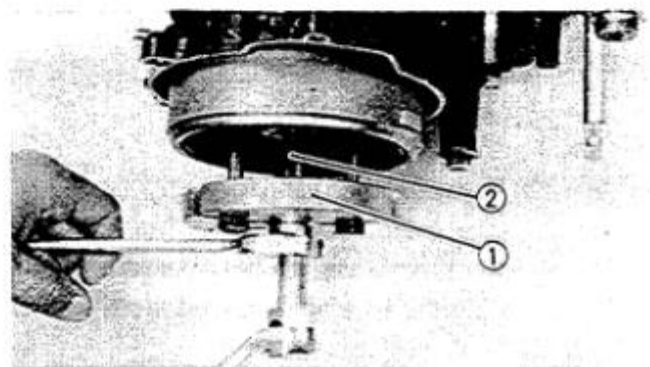

5. Remove:

- Flywheel magneto
Use the Flywheel puller (90890-01362) ① with the Adapter (90890-04063) ②.

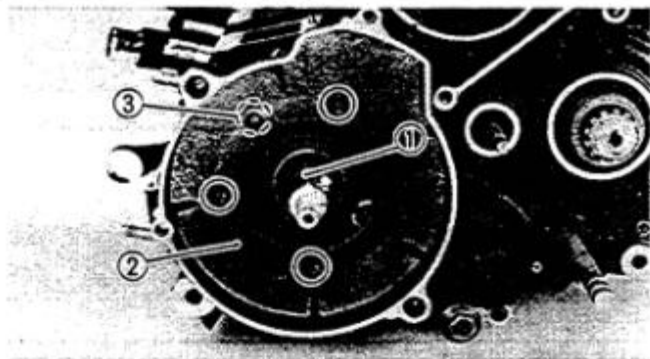

6. Remove:
- Key ①
 - Flywheel cover ②
 - Dowel pin ③

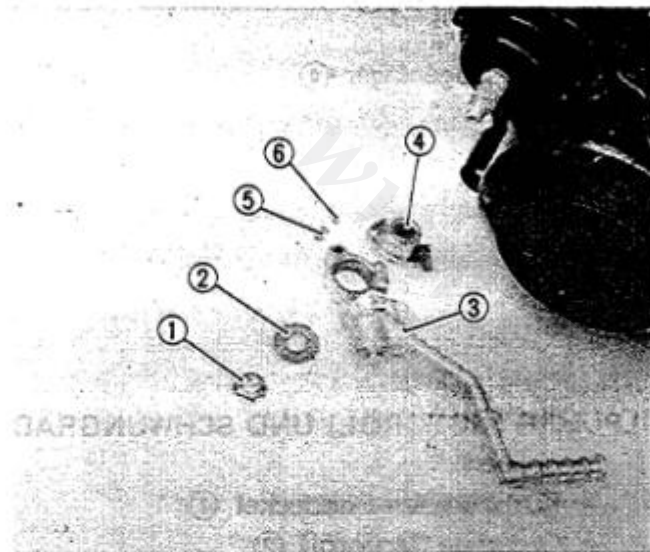

WATER PUMP AND CRANKCASE COVER (RIGHT)

1. Remove:
- Nut (Kick crank) ①
 - Washer ②
 - Kick crank ③
 - Collar ④

NOTE:

Do not lose the spring ⑤ and ball ⑥.

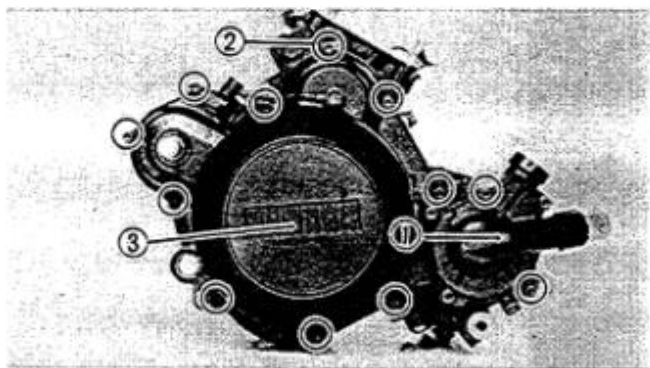

2. Remove:
- Bolts
 - Water pump ①
 - Clamp ②
 - Crankcase cover ③
 - Gasket
 - Dowel pins

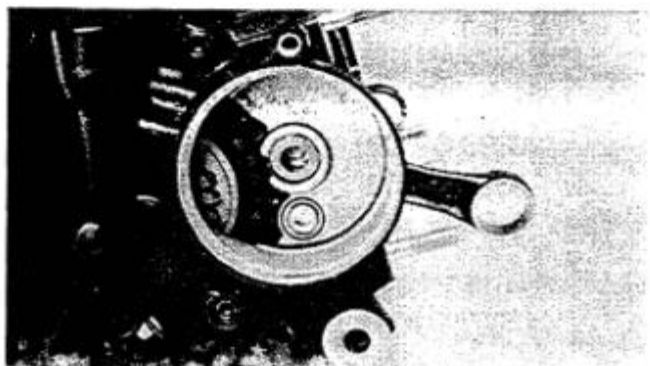

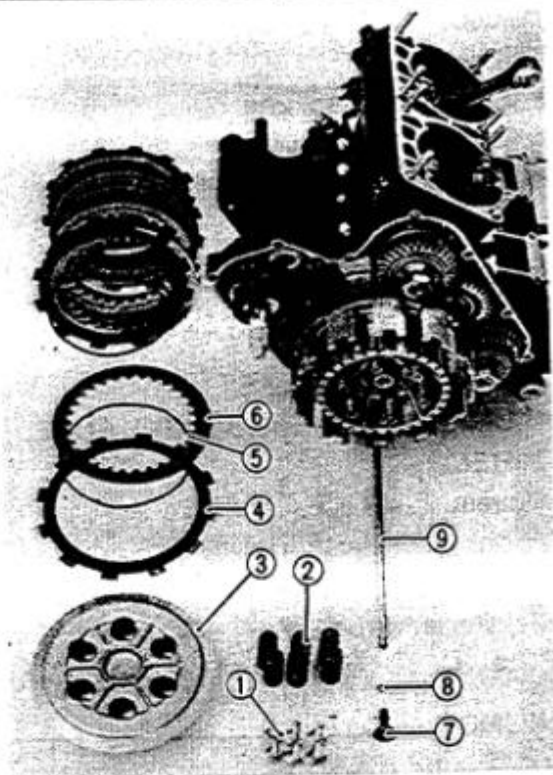

CLUTCH AND KICK GEAR

1. Remove:

- Clutch spring bolts ①
- Clutch spring ②
- Pressure plate ③
- Friction plates ④
- Ring-spring ⑤
- Clutch plate ⑥
- Push rod No. 1 ⑦
- Ball ⑧
- Push rod No. 2 ⑨

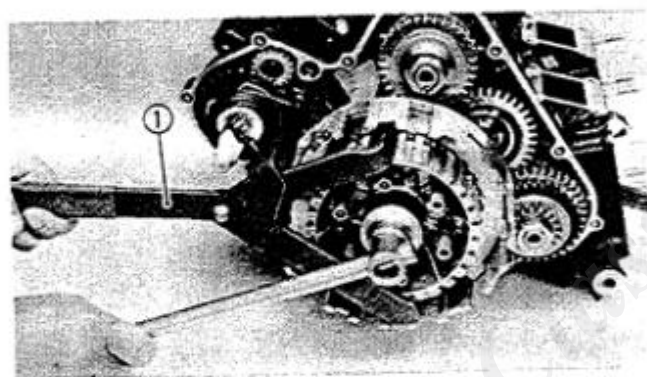

2. Bend:

- Lock washer tab (Clutch boss)

3. Attach:

- Universal Clutch Holder (90890-04086) ①

4. Loosen:

- Clutch boss nut

NOTE:

Do not remove the clutch boss and clutch housing at this point.

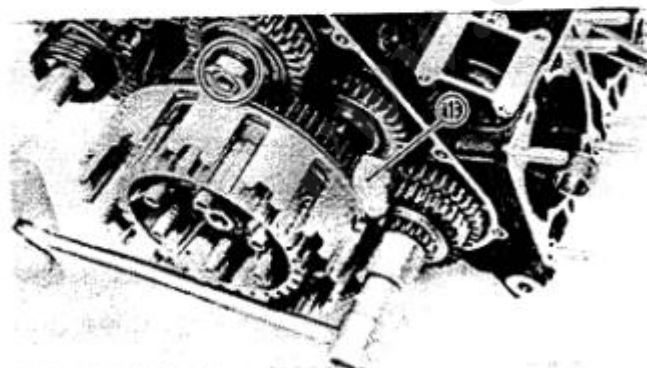

5. Place a piece of rolled rag ① or piece of lead between the primary gears, and loosen the primary gear securing nuts.

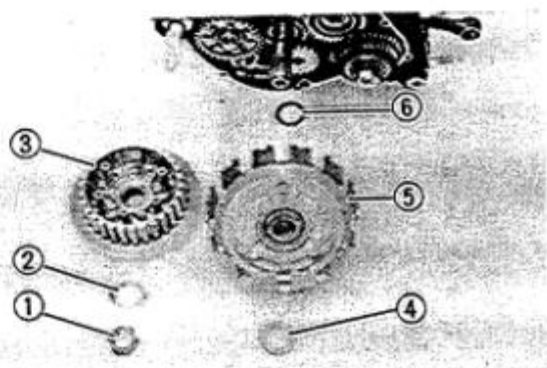

6. Remove:

- Clutch boss nut ①
- Lock washer ②
- Clutch boss ③
- Thrust washer ④
- Clutch housing ⑤
- Plate washer ⑥

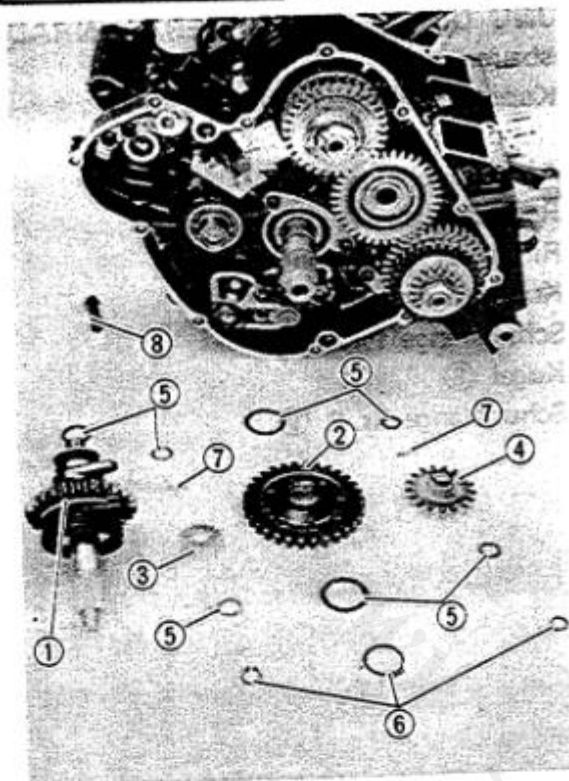

7. Remove:

- Kick gear ①
- Kick idle gear ②
- Oil pump gear (Engine oil) ③
- Oil pump gear (Transmission oil) ④

- ⑤ Washer
- ⑥ Circlip
- ⑦ Dowel pin
- ⑧ Oil pump drive shaft

PRIMARY GEAR AND CHANGE SHAFT

1. Remove:

- Change shaft ①
- Bolt ②
- Shift cam stopper lever ③
- Stopper lever spring ④
- Nuts ⑤
- Conical washers ⑥
- Collars ⑦
- Drive gear (Water pump) ⑧
- Plate washers ⑨
- Zero lash gears ⑩
- Primary gears ⑪
- Drive gear (Balancer gear) ⑫
- Keys ⑬

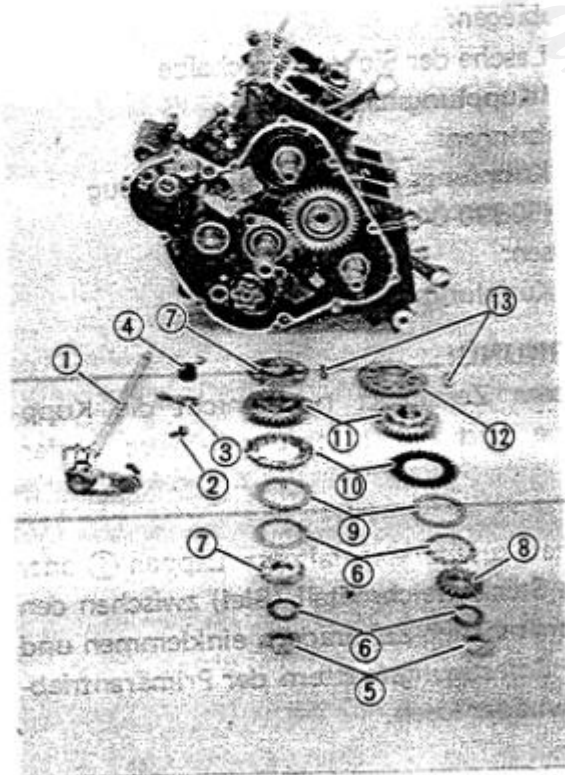

OIL PUMP (TRANSMISSION OIL)

1. Remove:

- Bolts ①
- Cover ②
- Gasket ③
- Screws ④
- Oil pump ⑤
- O-ring ⑥
- Idle gear ⑦
- Dowel pin ⑧
- Washer ⑨
- Drive shaft ⑩

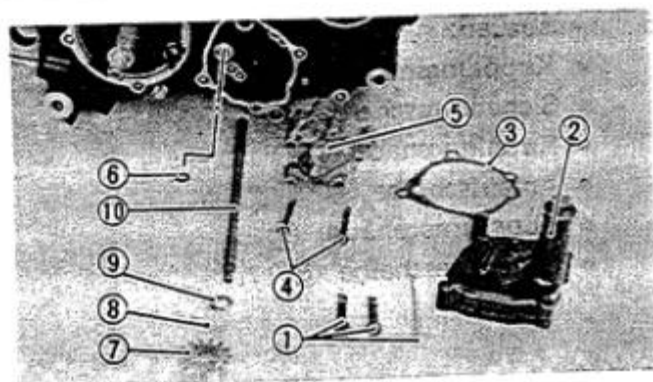

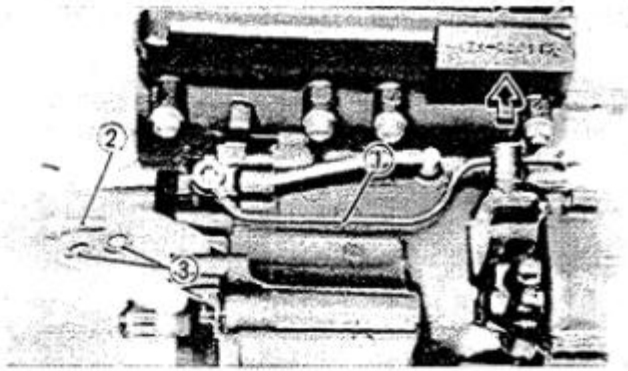

2. Remove:
 - Oil delivery pipe ①

- ② Union bolt
- ③ Copper washers

TRANSMISSION

1. Remove:
 - Bolts (Crankcase cover)

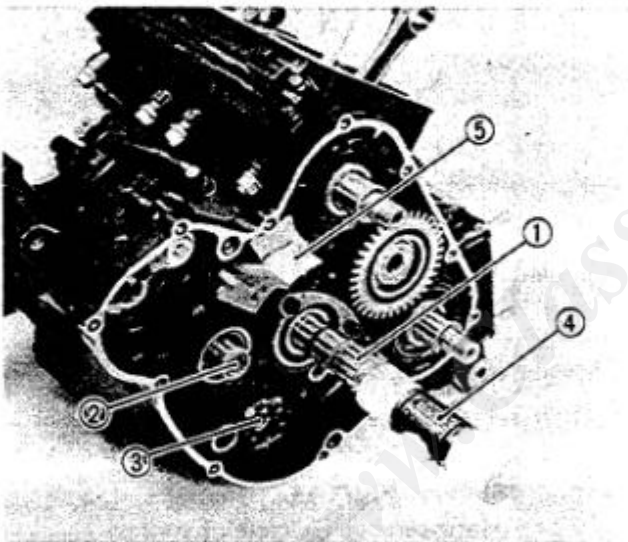
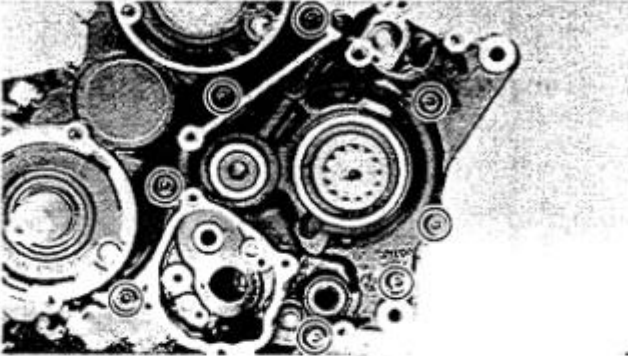

2. Remove the transmission cover together with the transmission assembly by tapping the main axle ①, drive axle ②, and shift cam segment ③ alternately with a soft-faced hammer ④.

NOTE:

The removal of the oil baffle ⑤ is unnecessary unless the right crankcase has to be replaced.

CAUTION:

When separating the crankcase, be sure the shift cam segment star ① aligns with its corresponding contours in the crankcase.

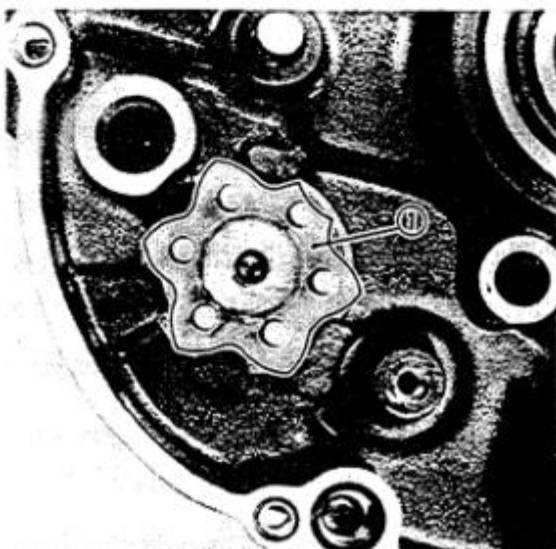

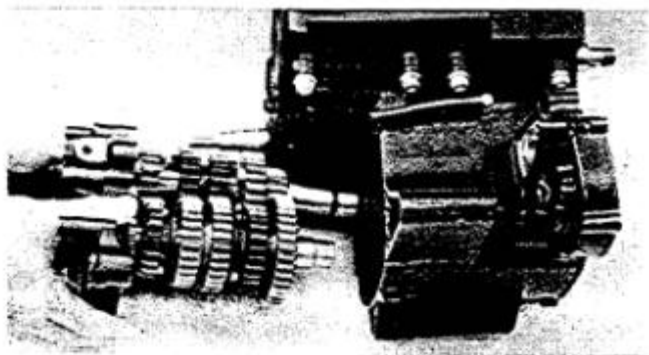

3. Pull out the transmission cover together with the transmission assembly.

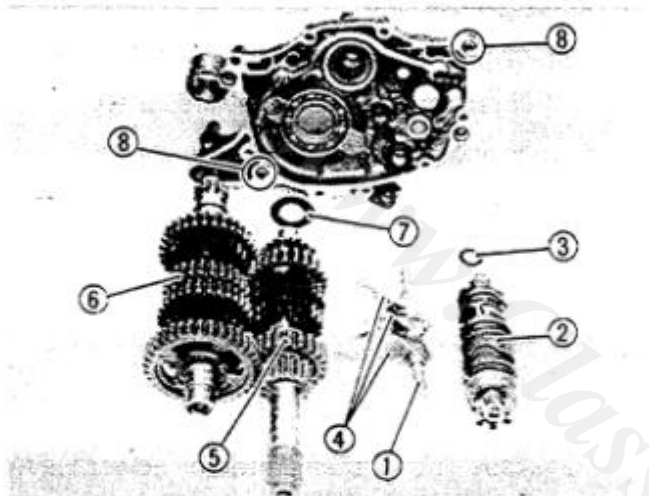

4. Remove:
 - Guide bar ①
 - Shift cam ②
 - Washer ③
 - Shift forks ④
 - Main axle (Sub-assembly) ⑤
 - Drive axle (Sub-assembly) ⑥
 - Washer ⑦
 - Dowel pin ⑧

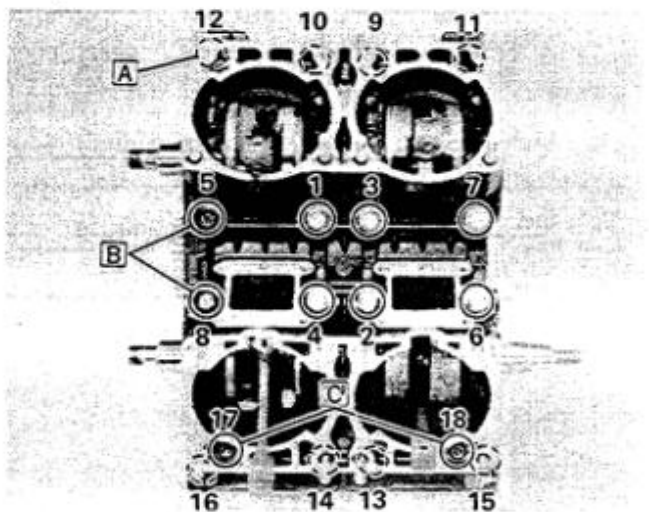

CRANKCASE, CRANKSHAFT, AND BALANCER SHAFT

1. Remove:
 - Bolts (Crankcase)
 - Nut (Crankcase)
 - Crankcase (Upper)

NOTE:

- Remove the bolts starting with the highest numbered one.
- The embossed numbers in the crankcase designate the crankcase tightening sequence.

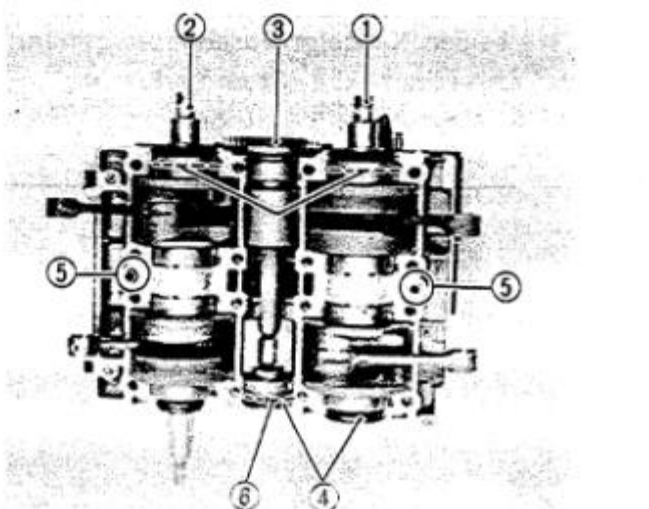

- [A] Nut with washer
 [B] Black color bolts
 [C] Hexagon socket bolt with washer

2. Remove:
 - Crankshaft (Upper) ①
 - Crankshaft (Lower) ②
 - Balancer shaft ③
 - Blind seals ④
 - Dowel pins ⑤
 - Half clips ⑥



INSPECTION AND REPAIR

CYLINDER HEAD

1. Eliminate:
 - Carbon deposit
Use rounded scraper.

NOTE: _____
Do not use a sharp instrument and avoid damaging or scratching:

- Spark plug threads
- Cylinder head

2. Measure:
 - Cylinder head warpage
Out of specification → Resurface/Replace.

Cylinder Head Warp Limit:
Less than 0.05 mm (0.002 in)

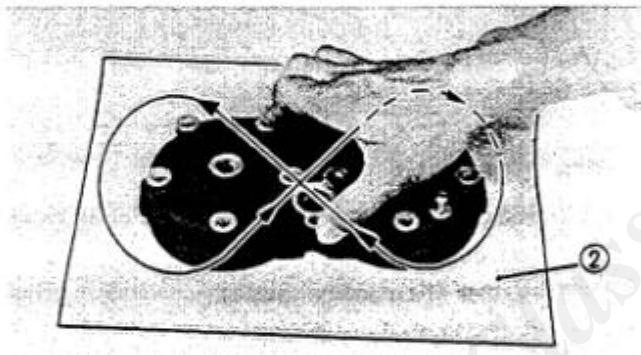
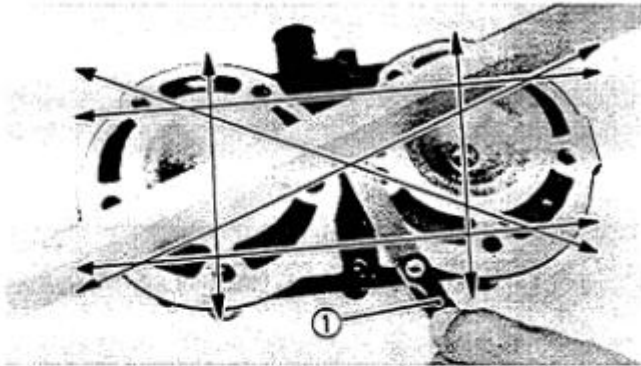

- ① Feeler gauge
- ② Sandpaper (400 ~ 600 grit wet sandpaper)

CYLINDER

1. Inspect:
 - Cylinder wall
Wear/Scratches → Rebore or replace.
2. Measure:
 - Cylinder bore "C"
Use Cylinder Bore Gauge ①.
Out of specification → Rebore.

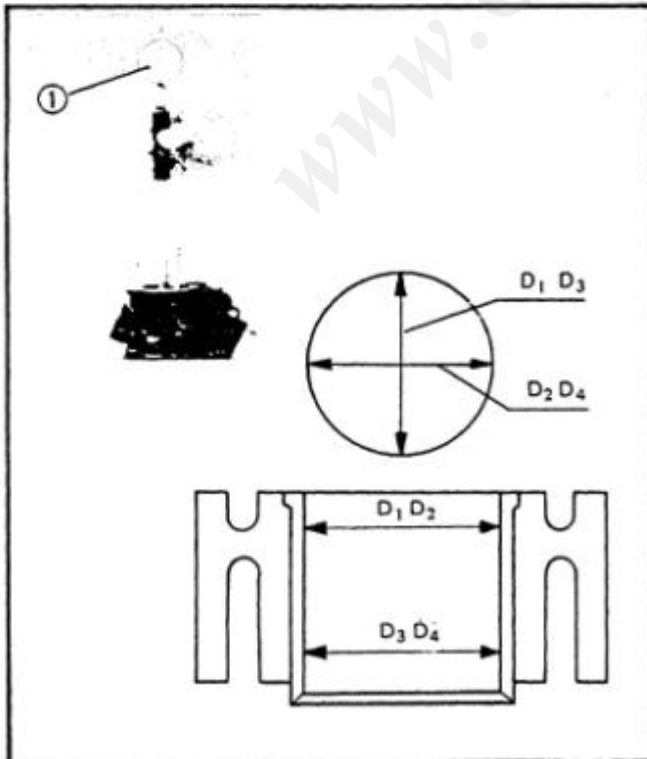

	Standard	Wear limit
Cylinder Bore C:	56.40 ~ 56.42 mm (2.2205 ~ 2.2213 in)	56.50 mm (2.2244 in)
Cylinder Taper T:	—	0.05 mm (0.002 in)

C = Maximum D
T = (Maximum D₁ or D₂)
— (Minimum D₃ or D₄)

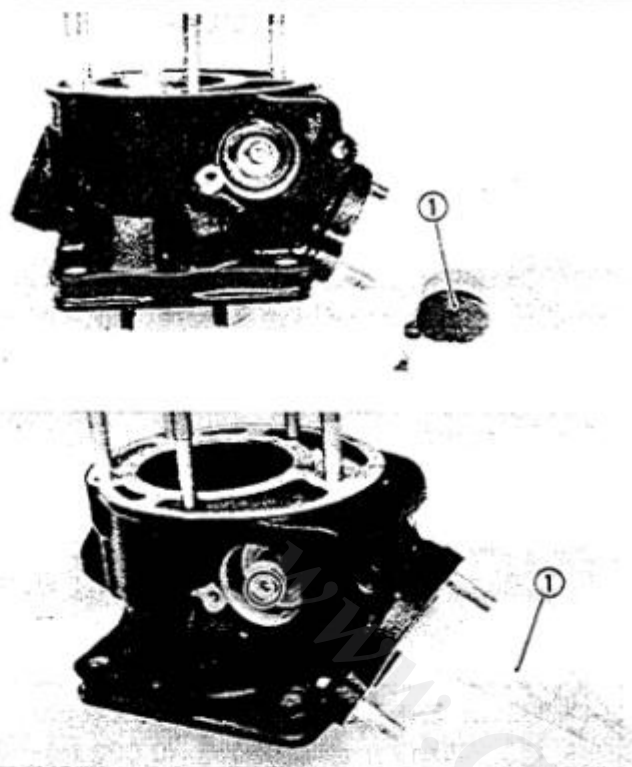

YPVS (YAMAHA POWER VALVE SYSTEM)

Removal

- Remove:
 - Valve holder 1 ①
 - Holder retainer
 - Valve holder 2
 - Oil seal
- Remove:
 - Valve securing bolt

NOTE:

Use a wooden piece ① through the exhaust port to steady the valve.

- Valve
- Dowel pins

Inspection

- Inspect:
 - Valve ①
Wear/Scratches → Replace.
 - O-rings ②
Wear/Damage → Replace.
 - Oil seal ③
Wear/Damage → Replace.
 - Holders ④
Wear/Scratches → Replace.

Assembly

- Grease the valve holders ④, O-rings ②, and oil seal ③.



Molybdenum Disulfide Grease

- Install:
 - Valve ①
 - Dowel pins
- Tighten:
 - Valve securing bolt ⑤

Ⓐ VALVE MARK



Power Valve:

7 Nm (0.7 m·kg, 5.1 ft·lb)

Do not over tighten.

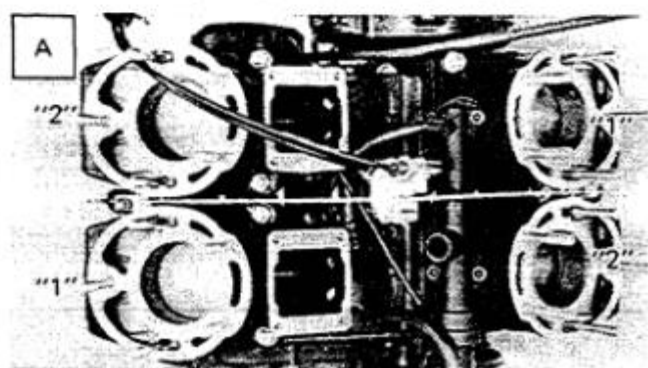
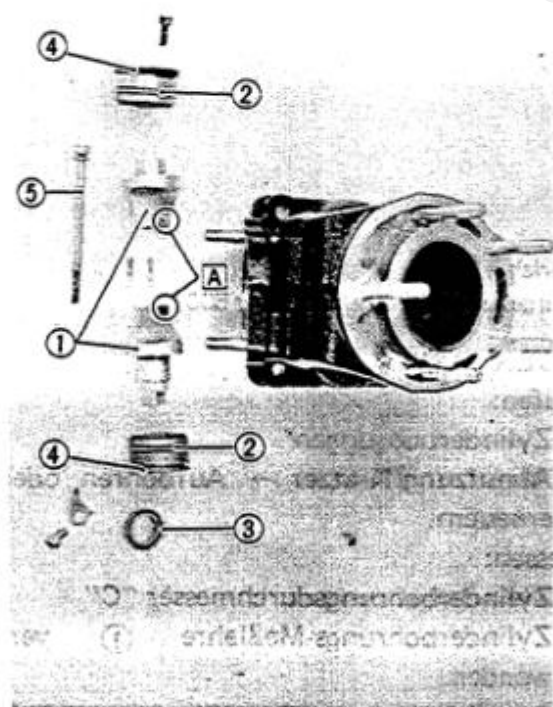

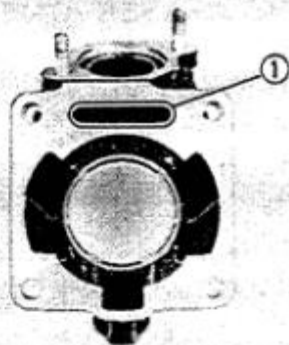

5. Tighten:
 - Valve holder
 - Holder retainer



Power Valve Holders:
7 Nm (0.7 m·kg, 5.1 ft·lb)

6. Install:
 - Rubber seal ①

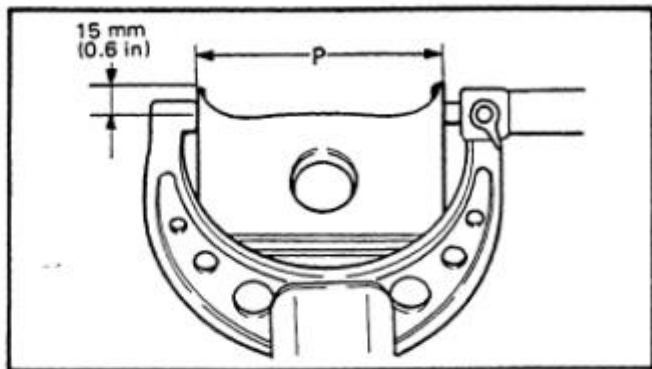

PISTON, PISTON RING, PISTON PIN, AND CONNECTING ROD BEARING

Piston

1. Inspect:
 - Piston wall
Wear/Scratches/Damage → Replace.
2. Measure:
 - Piston outside diameter "P"
Use a micrometer.
Out of specification → Replace.

NOTE:

Measurement should be made at a point 15 mm (0.6 in) above the bottom edge of the piston.

	Size "P"
Standard	56.39 ~ 56.40 mm (2.220 ~ 2.221 in)
Overize 1	56.65 mm (2.230 in)
Overize 2	56.90 mm (2.240 in)

3. Measure:
 - Piston clearance
Out of specification → Rebore cylinder and/or replace piston.



Piston Clearance = C - P:
0.060 ~ 0.065 mm
(0.0024 ~ 0.0026 in)
Limit:
0.10 mm (0.004 in)

C: Cylinder bore P: Piston outside diameter

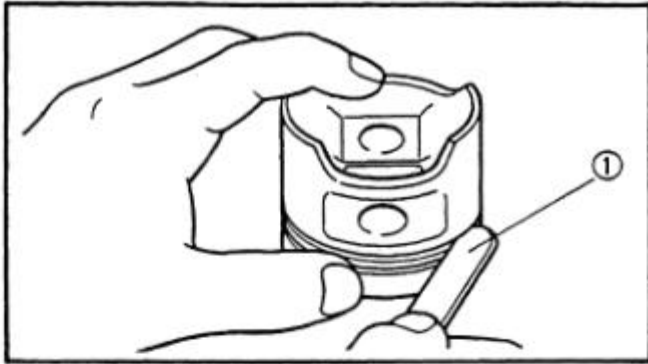

Piston Ring

1. Measure:

- Side clearance

Use Feeler Gauge ①.

Out of specification → Replace piston and/or rings.

	Side Clearance:	
	Standard	Limit
Top Ring	0.030 ~ 0.050 mm (0.0012 ~ 0.0020 in)	0.10 mm (0.0039 in)
2nd Ring	0.030 ~ 0.065 mm (0.0012 ~ 0.0026 in)	0.11 mm (0.0043 in)

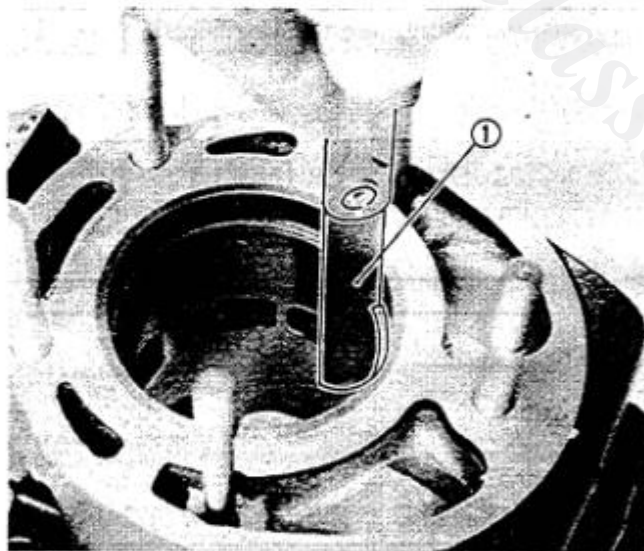

2. Position:

- Piston ring

(into cylinder)

Push the ring with the piston crown.

3. Measure:

- End gap

Use feeler gauge ①.

Out of specification → Replace rings as set.

	End Gap:	
	Standard	Limit
Top Ring	0.30 ~ 0.45 mm (0.012 ~ 0.018 in)	0.70 mm (0.028 in)
2nd Ring	0.30 ~ 0.45 mm (0.012 ~ 0.018 in)	0.70 mm (0.028 in)

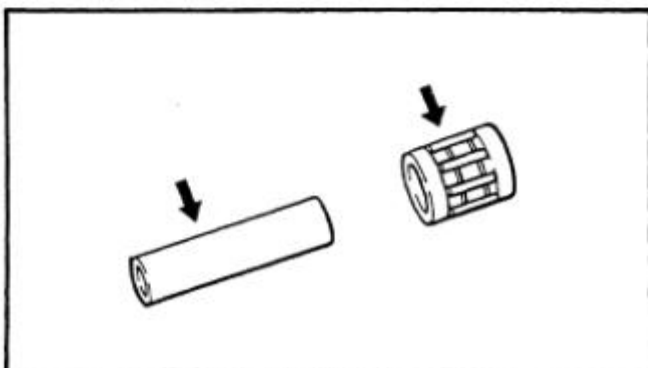

Piston Pin and Connecting Rod Bearing

1. Check:

- Piston pin
- Connecting rod bearing

Wear/Scratches/Heat discoloration → Replace the piston pin and bearing as a set.

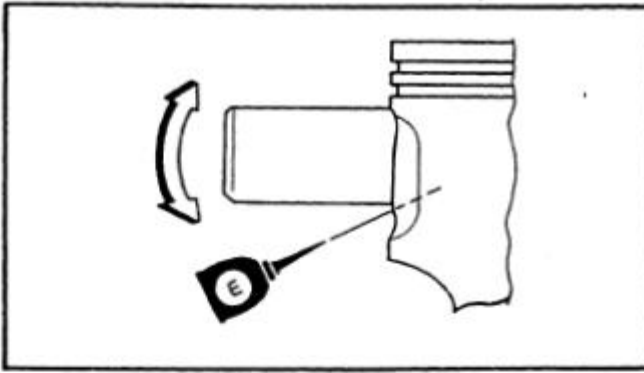

2. Position:
 - Piston pin
(into piston)
3. Check:
 - Free play
(when pin is in place in piston)
Free play → Replace piston pin
and/or piston.

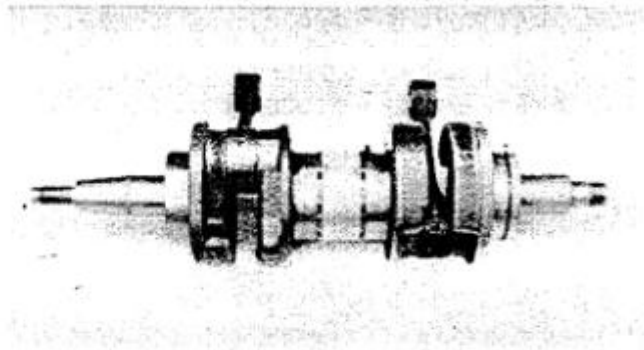

CRANKSHAFT

1. Measure:
 - Runout
Use V-Blocks and Dial Gauge (90890-03097).
Out of specification → Replace.



Runout Limit (A) :
0.03 mm (0.0012 in)

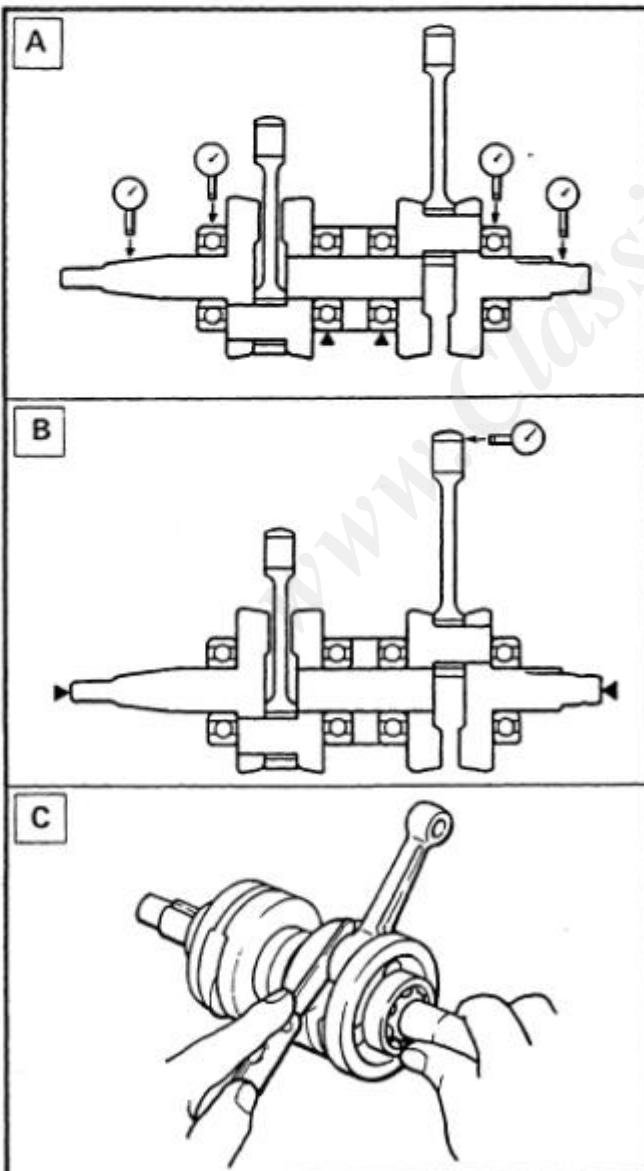

2. Measure:
 - Free play
Use the Dial Gauge (90890-03097).
Out of specification → Replace
the crankshaft assembly.



Small End Free Play Limit (B) :
2.0 mm (0.08 in)

3. Measure:
 - Connecting rod side clearance
Use a feeler gauge.
Out of specification → Replace
the crankshaft assembly.



Side Clearance Limit (C) :
0.1 mm (0.04 in)

4. Inspect:
 - Bearings
Pitting/Damage → Replace the bearing(s) or crankshaft assembly.

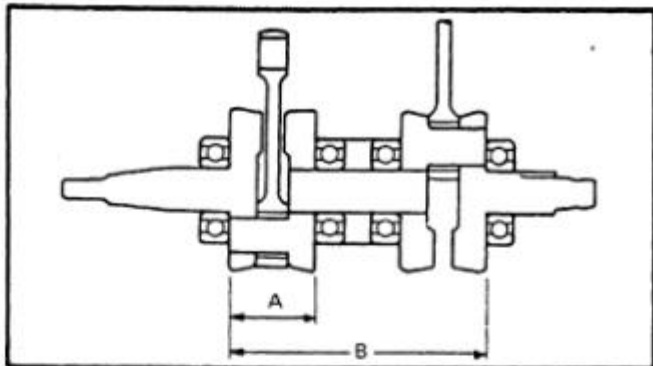
**CRANKSHAFT LENGTH:**

Crank Width "A":	55.95 ~ 56.00 mm (2.2028 ~ 2.2047 in)
Assembly Width "B":	167.85 ~ 168.00 mm (6.6083 ~ 6.6014 in)

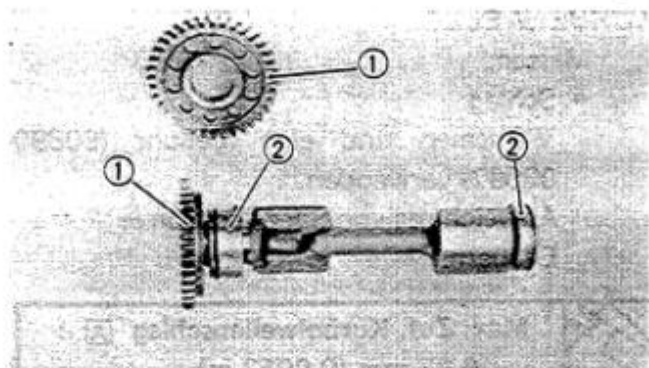
**BALANCER SHAFT**

- Inspect:
 - Gears ①
Damage/Wear → Replace.
- Inspect:
 - Bearings ②
Pitting/Damage → Replace.

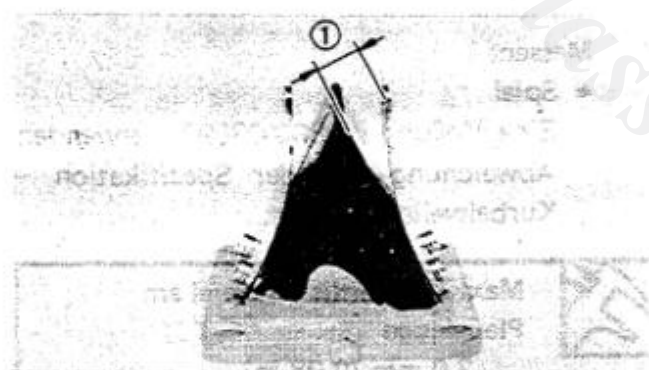
**REED VALVE AND CARBURETOR JOINT****Reed Valve**

- Measure:
 - Valve stopper height ①
Out of specification → Replace.



Valve Bending Limit ①:
8.7 ~ 9.3 mm (0.343 ~ 0.366 in)

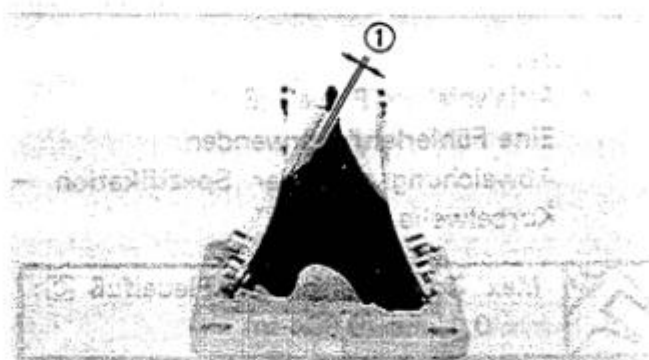

- Measure:
 - Valve bending ①
Out of specification → Replace.

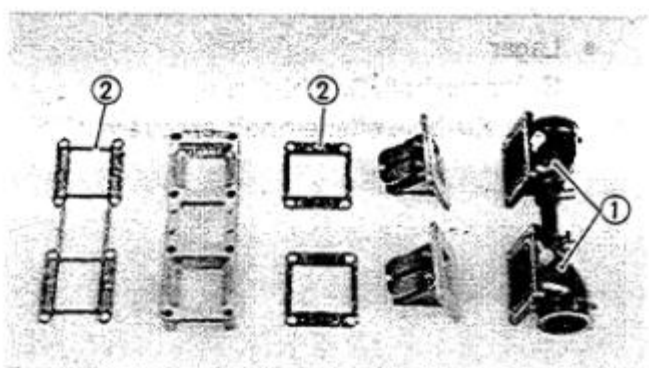

Valve Stopper Height ①:
0.5 mm (0.02 in)

**Carburetor Joint**

- Inspect:
 - Carburetor joint ①
Cracks/Wear/Damage → Replace.
 - Gaskets ②
Damage → Replace.

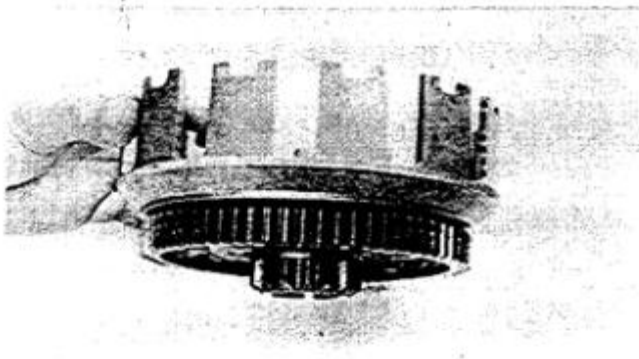

CLUTCH

Clutch Housing

1. Inspect:
 - Dogs on the housing ①.
Cracks/Wear/Damage → Deburr or replace.

Clutch Boss

The clutch boss contains a built-in damper beneath the first clutch friction plate. It is not necessary to remove the wire circlip ① and disassemble the built-in damper unless there is serious clutch chattering.

1. Inspect:
 - Clutch plate
Wear/Scratches → Replace.

	Clutch Plate Thickness [A] :
	2.0 mm (0.079 in)
	Other Clutch Plate (6 pcs)
	Thickness:
	1.4 ~ 1.7 mm (0.055 ~ 0.067 in)

NOTE:

The "OUT SIDE" mark on the damper spring [B] should face outward.

- Install the clutch plate [A] so that the rounded edge is on the outside.

2. Inspect:
 - Clutch boss splines
Scoring/Wear/Damage → Replace clutch boss assembly.

NOTE:

Scoring on the clutch plate splines will cause erratic operation.

Friction Plates

1. Inspect:
 - Friction plate ①
Damage/Wear → Replace friction plate as a set.

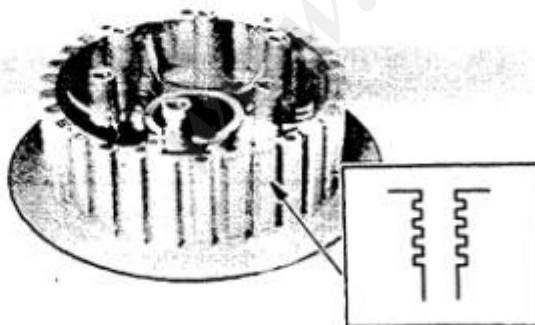
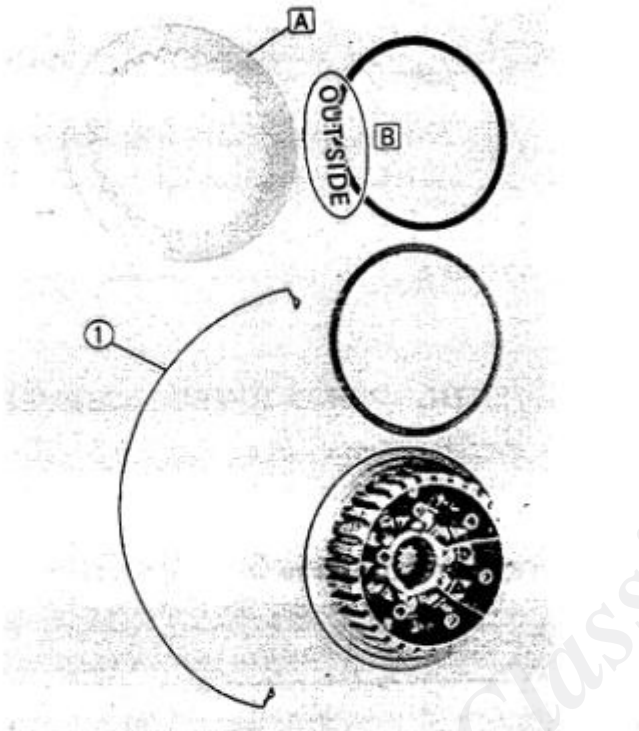

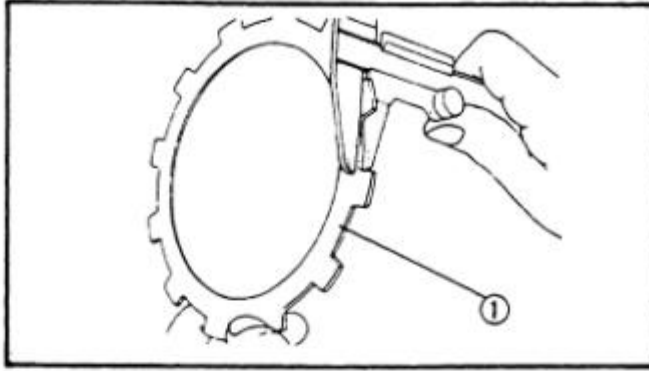

2. Measure:

- Friction plate (1) thickness
Measure at all four points.
Out of specification → Replace friction plate as a set.



Wear Limit:
2.8 mm (0.11 in)

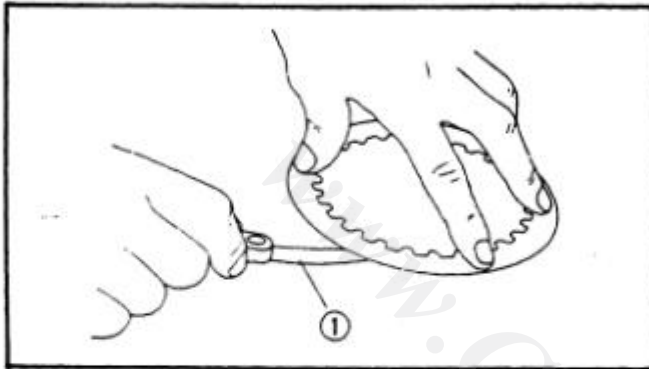

Clutch Plates

1. Measure:

- Clutch plate warpage
Use surface plate and Feeler Gauge (1).
Out of specification → Replace.



Warp Limit:
0.1 mm (0.004 in)

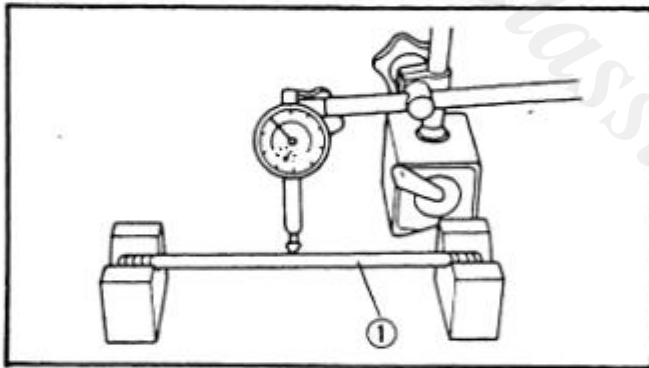

Push Rod

1. Measure:

- Push rod runout (long rod (1))
Use V-Blocks and Dial Gauge (90890-03097)
Out of specification → Replace.



Bending Limit:
0.5 mm (0.020 in)

2. Inspect:

- O-ring
(on short rod)
Wear/Cracks/Damage → Replace.

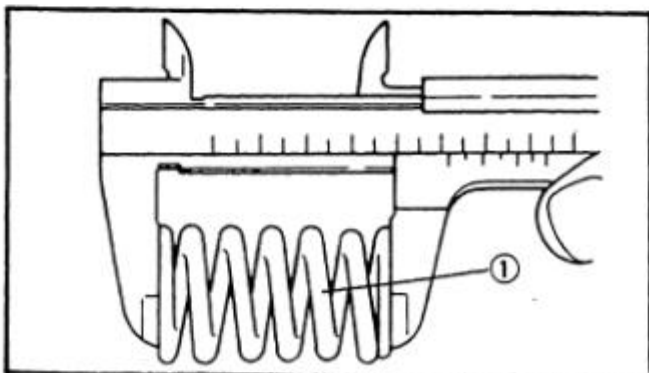

Clutch Spring

1. Inspect:

- Clutch spring (1)
Wear/Bends/Cracks → Replace.

2. Measure:

- Clutch spring free length
Out of specification → Replace springs as a set:



Clutch Spring Minimum Length:
41.5 mm (1.634 in)

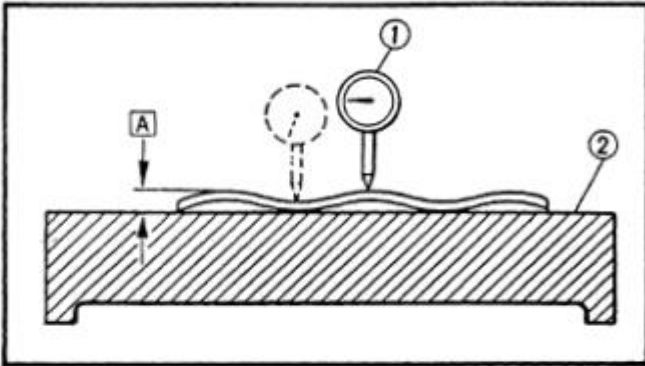
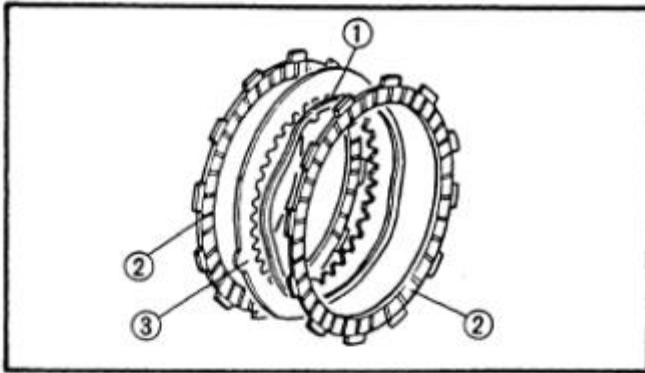

Ring-Spring

1. Inspect:

- Ring-springs ①
Wear/Bends/Cracks → Replace.

② Friction plate

③ Clutch plate

2. Measure:

- Ring-spring height
Use the Dial Gauge (90890-03094)
① and surface plate ②.
Out of specification → Replace.



Ring-Spring Minimum Height [A] :
3.25 mm (0.128 in)

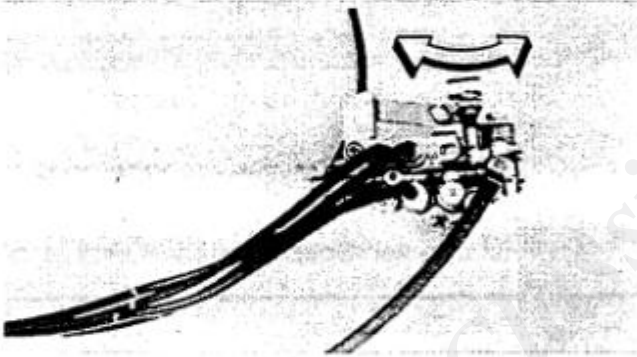

OIL PUMP (ENGINE OIL) AND DELIVERY PIPE

Oil Pump

1. Inspect:

- Oil pump
Unsmooth lever operation/Oil leaks
→ Replace.

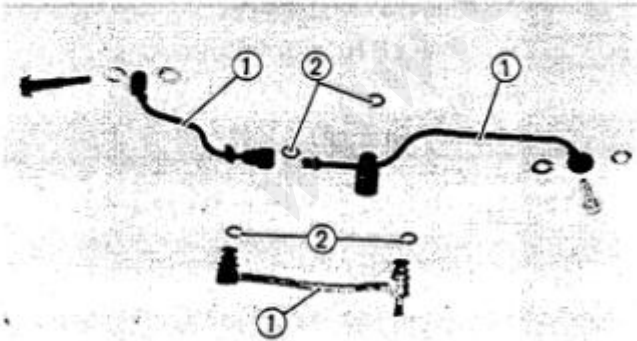

Delivery Pipe

1. Inspect:

- Oil pipes ①
Contamination → Clean.
- O-rings ②
Wear/Cracks/Damage → Replace.

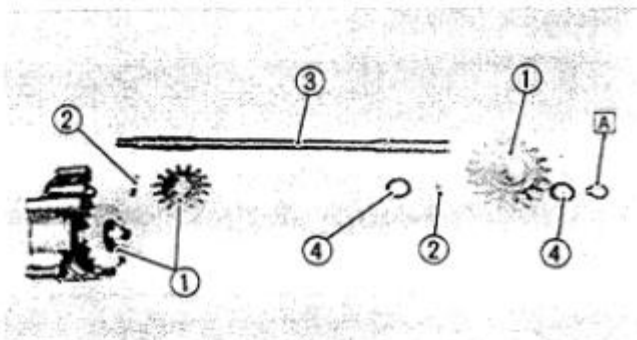

OIL PUMP (TRANSMISSION OIL)

1. Inspect:

- Gears ①
Wear/Damage → Replace.

WARNING:

Always use a new circlip [A] .

② Dowel pin

③ Drive shaft

④ Washer

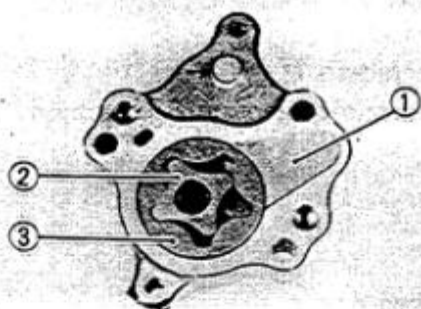

- ① Housing
- ② Inner rotor
- ③ Outer rotor

2. Measure:

- Housing ③ / Outer rotor ① clearance
Use Feeler Gauge.
Out of specification → Replace oil pump assembly.

	Standard Clearance A :
	0.10 ~ 0.15 mm (0.004 ~ 0.006 in)
	Limit: 0.17 mm (0.0067 in)

3. Measure:

- Rotor/Housing clearance
Use a Feeler Gauge and straight edge.
Out of specification → Replace oil pump assembly.

	Standard Clearance B :
	0.04 ~ 0.09 mm (0.0016 ~ 0.0035 in)
	Limit: 0.12 mm (0.0047 in)

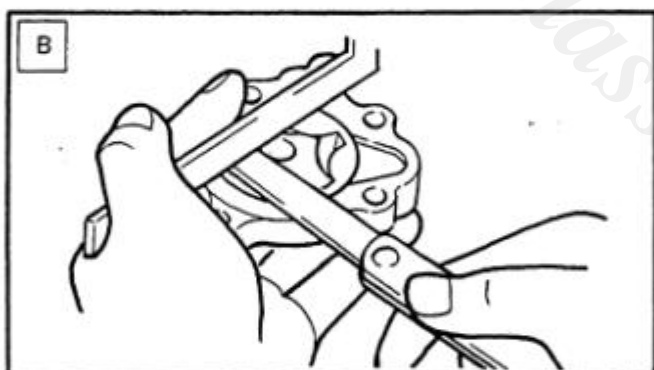
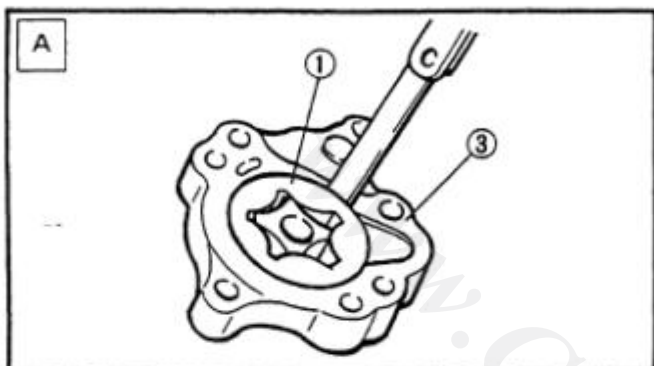

PRIMARY GEARS

1. Inspect:

- Gears ①
Damage/Wear → Replace.
- Gears (Zero lash gear) ②
Damage/Wear → Replace.

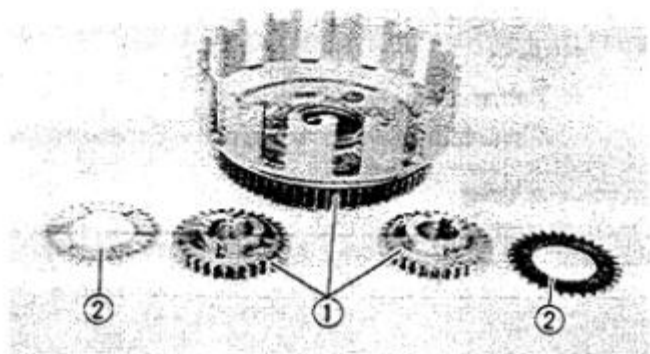

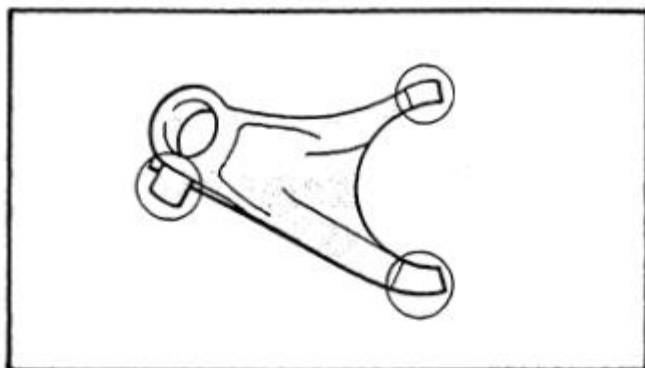

TRANSMISSION

Shift Fork

1. Inspect:
 - Shift forks
(on the gear and shift cam contact surfaces)
Wear/Chafing/Bends/Damage → Replace.
2. Check:
 - Shift fork movement
(on its guide bar)
Unsmooth operation → Replace fork and/or guide bar.

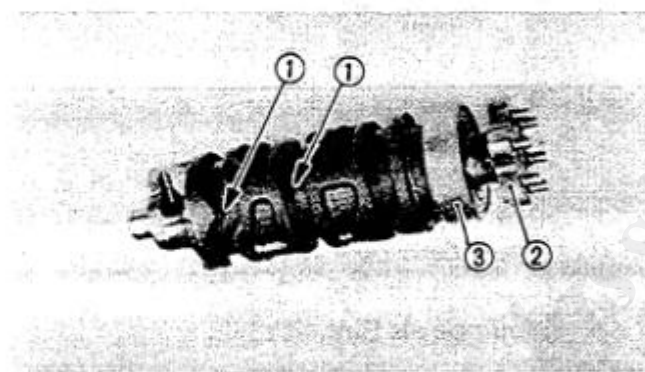

Shift Cam

1. Inspect:
 - Shift cam grooves ①
Wear/Damage/Scratches → Replace.
 - Shift cam segment ②
Damage/Wear → Replace.
 - Shift cam bearing ③
Pitting/Damage → Replace.

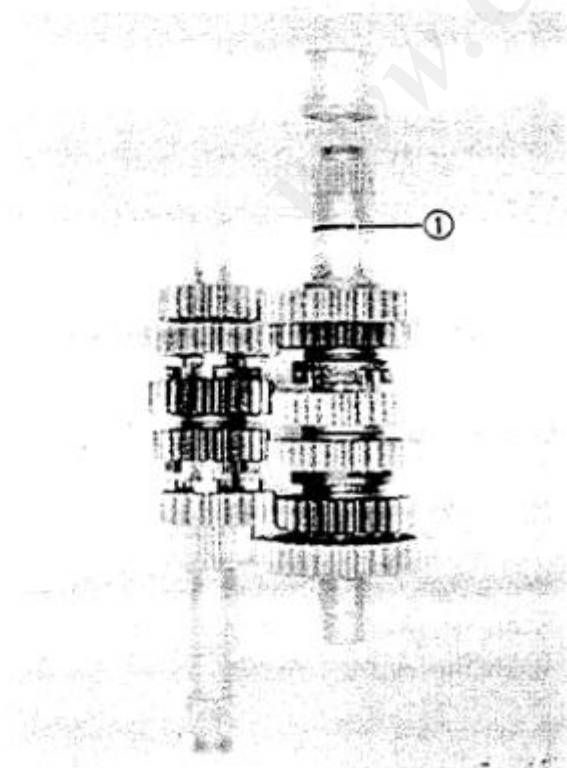

Gears

1. Inspect:
 - O-ring ①
Wear/Damage → Replace.
 - Gears
Damage/Wear → Replace.
 - Mating dogs
Cracks/Wear/Damage → Replace.
2. Check:
 - Gear movement
Unsmooth operation → Replace.

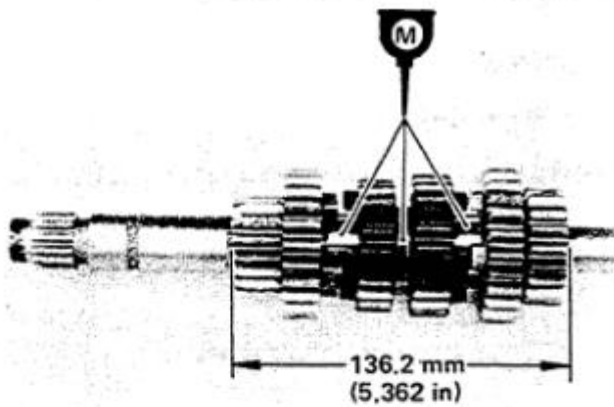

3. Measure:
 - Main axle (Assembled)



Main Axle Length:
136.2 mm (5.362 in)

4. Lubricate:
 - Main axle
 - Drive axle



Molybdenum Disulfide Oil

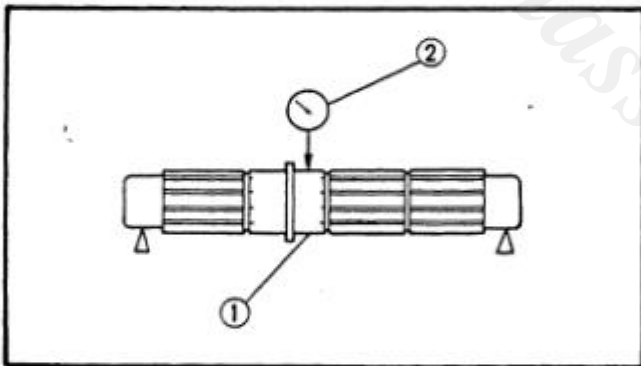

Main and Drive Axles

1. Measure:
 - Axle runout ①

Use centering device and Dial Gauge (90890-03097) ②.

Out of specification → Replace.



Runout Limit: 0.08 mm (0.0031 in)

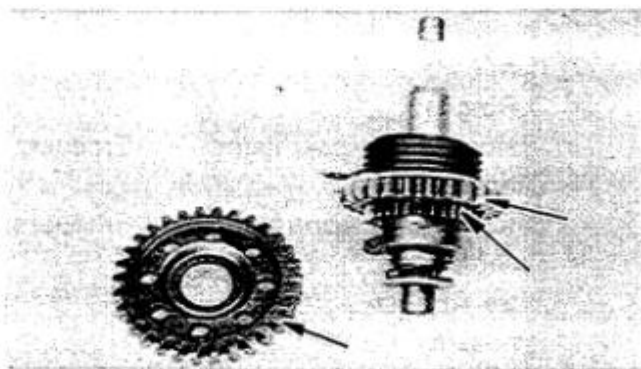

KICK STARTER

1. Inspect:
 - Gears

Wear/Damage → Replace.

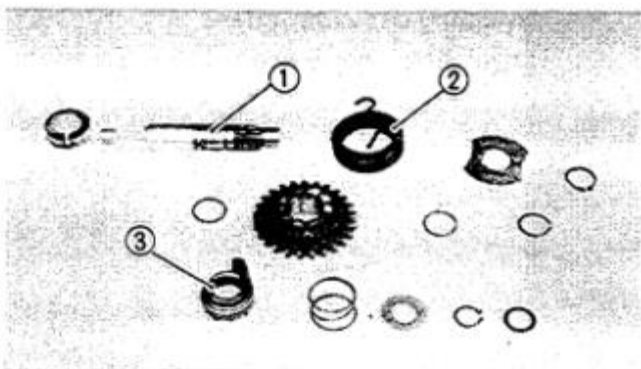

2. Inspect:
 - Kick shaft ①
 - Wear/Damage → Replace.
 - Springs ②
 - Wear/Damage → Replace.
 - Stopper (Ratchet wheel) ③
 - Wear/Damage → Replace.

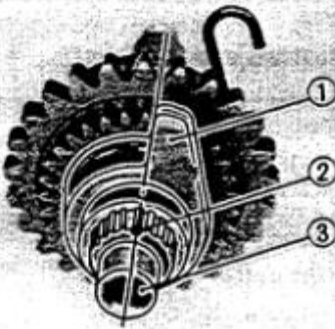

3. Install:
 - Stopper ①
 - See photo.

- ② Punch mark
- ③ Kick shaft

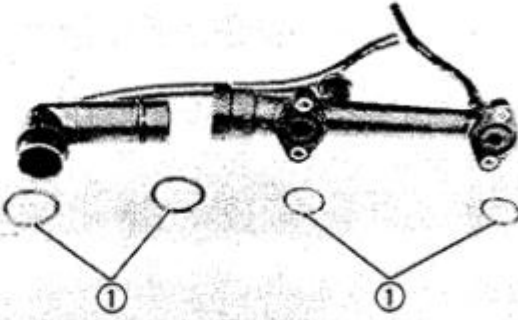

WATER JACKET

1. Inspect:
 - O-rings ①
Wear/Damage → Replace.
 - Hoses (All)
Wear/Cracks/Damage → Replace.

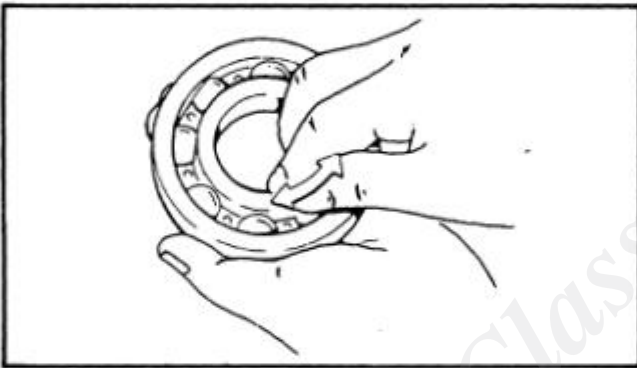

BEARINGS

1. Inspect:
 - Axle bearings
 - Shift cam bearing
Pitting/Damage → Replace.



2. Tighten:
 - Bearing retainer ①

	<p>Bearing Retainer: 10 Nm (1.0 m·kg, 7.2 ft·lb) LOCTITE®</p>
--	--

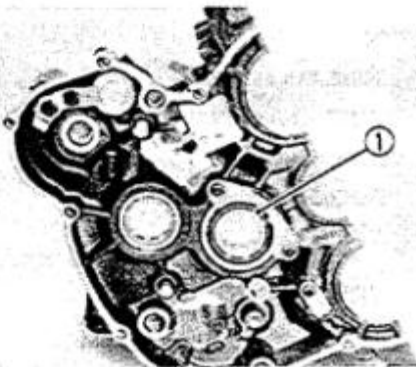

3. Tighten:
 - Bearing retainer ①

	<p>Bearing Retainer: 7 Nm (0.7 m·kg, 5.1 ft·lb) LOCTITE®</p>
--	---

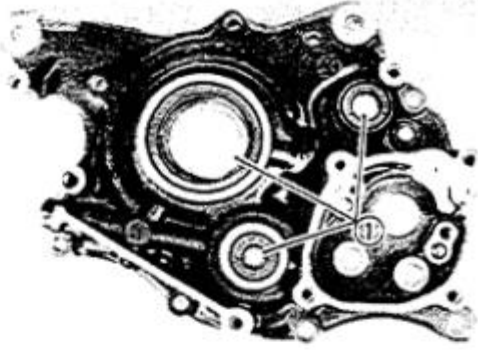

OIL SEALS AND BLIND SEALS

1. Inspect:

- Oil seals ①
Wear/Damage → Replace.
- Blind seals
Wear/Damage → Replace.

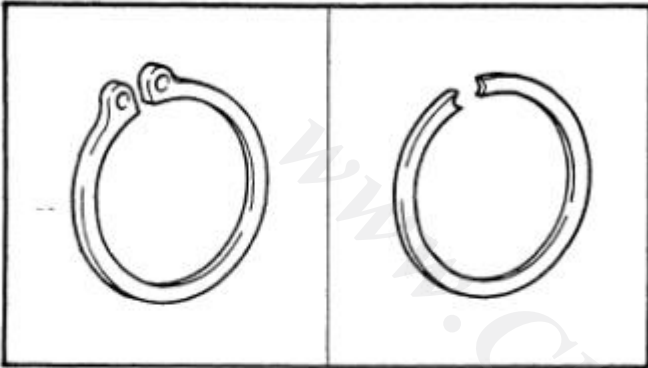

CIRCLIPS AND WASHERS

1. Inspect:

- Circlips
- Washers
Damage/Looseness/Bends → Replace.



ENGINE ASSEMBLY AND ADJUSTMENT

CRANKCASE ASSEMBLY (1)

- 1. Baffle plate
- 2. Union bolt
- 3. Copper washer
- 4. Delivery pipe
- 5. O-ring
- 6. Dowel pin
- 7. Retainer
- 8. Breather hose
- 9. Crankcase
- 10. Transmission cover

ENGINE OIL:

Recommended Oil:
 Yamaha oil 2T or equivalent
 Air cooled 2-stroke engine oil
 Oil Capacity:
 2.0 L (1.8 Imp qt, 2.1 US qt)

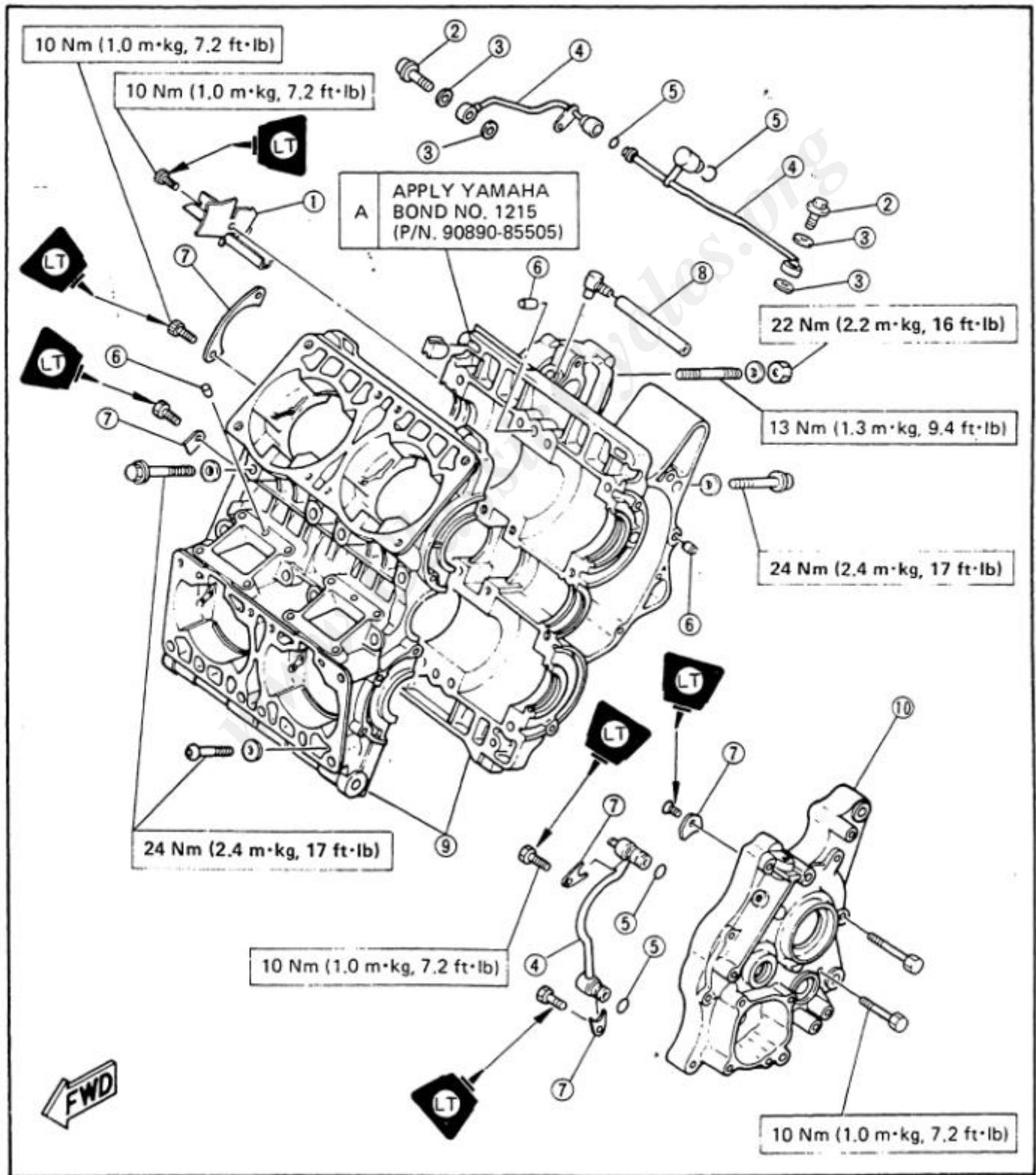



CRANKCASE ASSEMBLY (2)

- 1. Half clip
- 2. Balancer shaft
- 3. Bearing
- 4. Circlip
- 5. Blind seal
- 6. Top ring
- 7. 2nd ring
- 8. Expander
- 9. Piston pin
- 10. Thrust washer
- 11. Connecting rod
- 12. Woodruff key
- 13. Oil seal

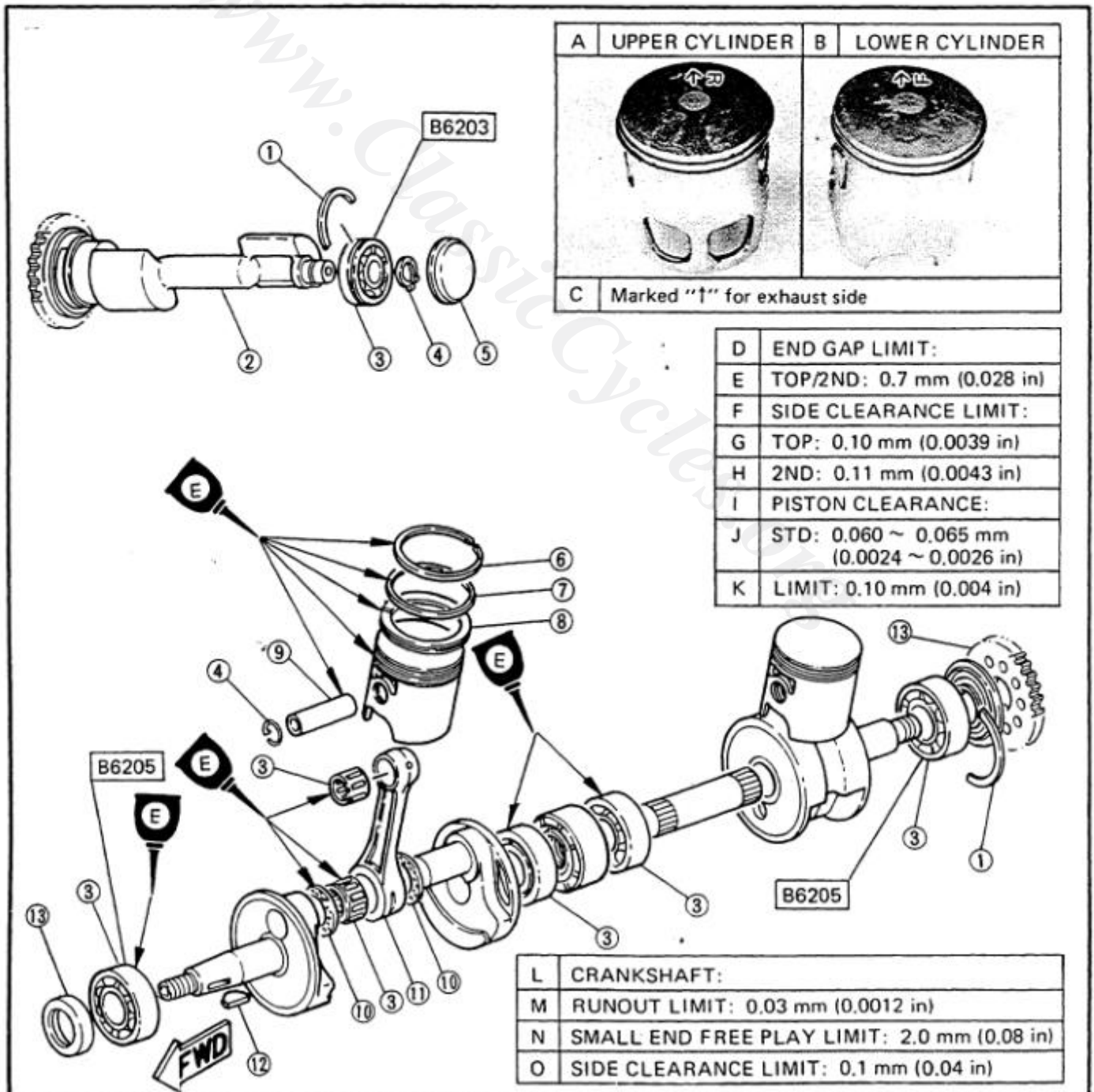

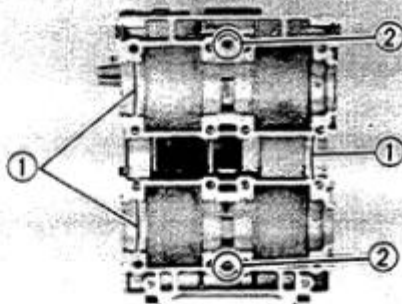

1. Install:
 - Half clips (Bearing clip) ①
 - Dowel pins ②

NOTE: _____
 Insert the bearing clips ① completely into the crankcase positioning grooves.

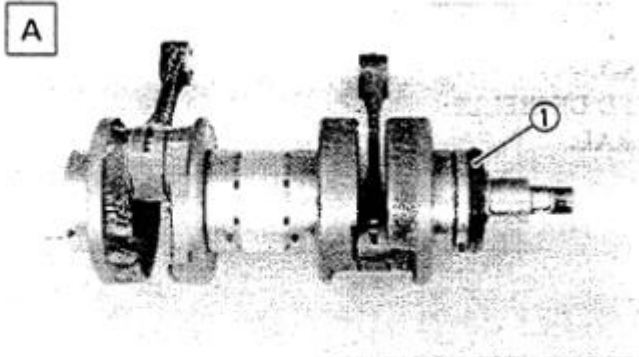

2. Place the oil seals ① onto the crankshafts.

A UPPER CRANKSHAFT

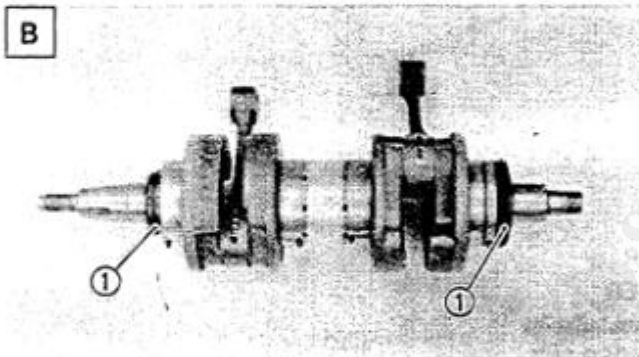

B LOWER CRANKSHAFT

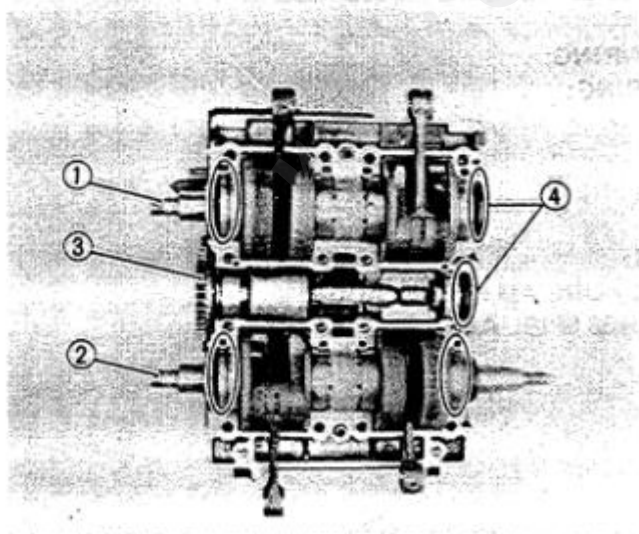

3. Install:
 - Crankshaft (Upper) ①
 - Crankshaft (Lower) ②
 - Balancer shaft ③
 - Blind seal ④

NOTE: _____
 • Insert the oil seal and blind seal flanges completely into the crankcase positioning grooves.
 • Be careful not to damage the seals during installation.
 • Be careful not to damage the crankcase during installation.

4. Apply Yamaha bond No. 1215 (90890-85505) to crankcase matching surfaces.

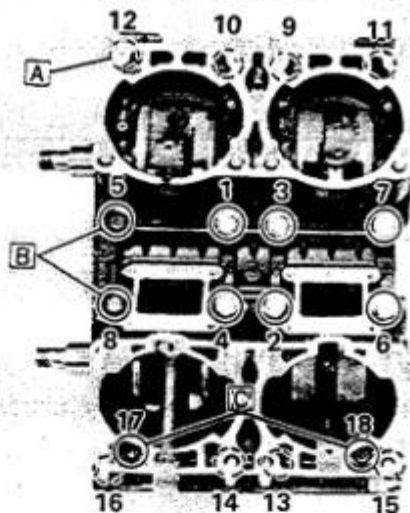

5. Install:
 - Crankcase (Upper)
6. Tighten:
 - Bolts
 - Nut

NOTE:

The embossed numbers in the crankcase designate the crankcase tightening sequence.

**Crankcase:**

Bolt: 24 Nm (2.4 m·kg, 17 ft·lb)

Nut: 22 Nm (2.2 m·kg, 16 ft·lb)

- A** Nut with washer
- B** Black color bolts
- C** Hexagon socket bolt with washer

www.ClassicCycles.org



1. Install:
 - Delivery pipe (With new O-rings) ①
2. Tighten:
 - Retainers

**Delivery Pipe:**

10 Nm (1.0 m·kg, 7.2 ft·lb)

LOCTITE®

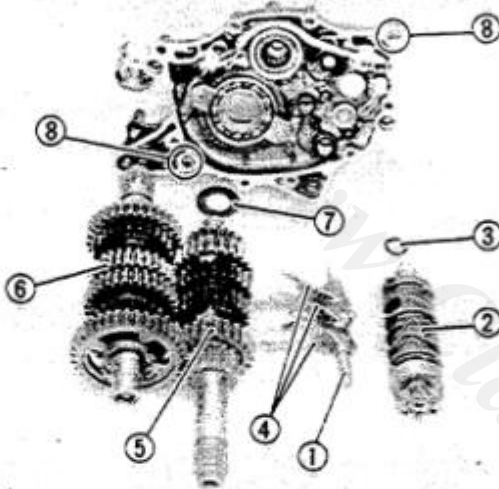

3. Install:
 - Dowel pins ⑧
 - Washer ⑦
 - Drive axle (Sub-assembly) ⑥
 - Main axle (Sub-assembly) ⑤
 - Shift forks ④
 - Washer ③
 - Shift cam ②
 - Guide bar ①
 (onto the transmission cover)
4. Apply Yamaha Bond No. 1215 (90890-85505) to the transmission cover matching surface.

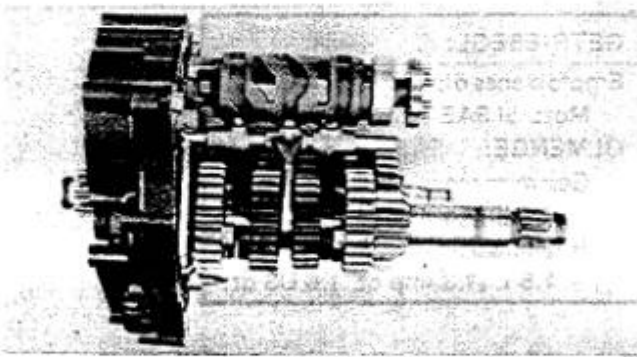

5. While holding the transmission assembly, install the transmission assembly into the crankcase.

CAUTION:

When installing the transmission assembly, be sure the shift cam segment star ① aligns with its corresponding contours in the crankcase.

6. Tighten:
 - Bolts

**Transmission Cover:**

10 Nm (1.0 m·kg, 7.2 ft·lb)

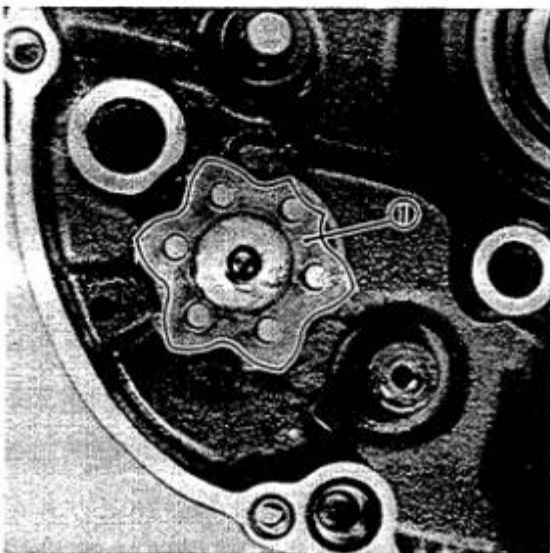

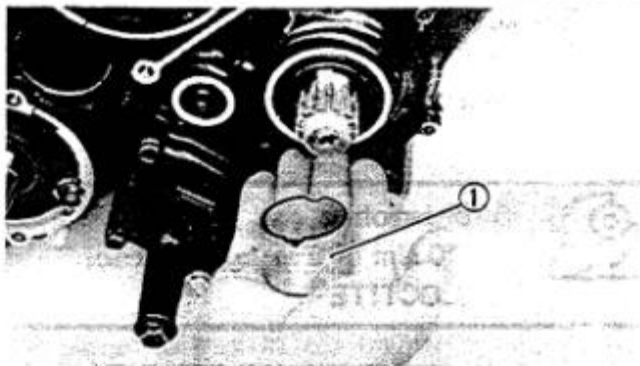

7. Apply grease to the collar ① and oil seal lips, and install it onto the drive axle.

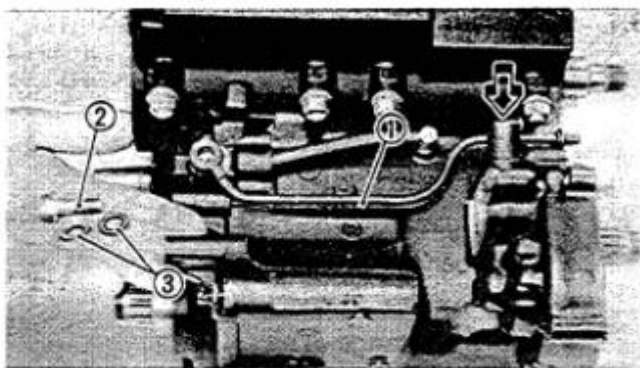

8. Install:
 - Delivery pipe (With new O-ring) ①
9. Tighten:
 - Union bolt ②



Delivery Pipe:

17.5 Nm (1.75 m·kg, 12.5 ft·lb)

- ③ Copper washer

OIL PUMP (TRANSMISSION OIL)

1. Assemble:
 - Oil pump
2. Tighten:
 - Screws



Oil Pump Assembly:

5 Nm (0.5 m·kg, 3.6 ft·lb)

- ① Gear
- ② Housing (inner)
- ③ Inner rotor
- ④ Drive shaft
- ⑤ Outer rotor
- ⑥ Housing (outer)
- ⑦ Strainer

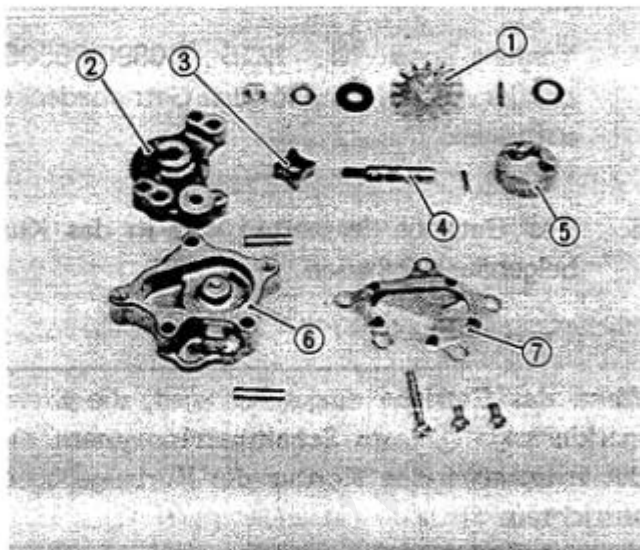

3. Install:
 - Drive shaft ⑩
 - Washer ⑨
 - Dowel pin ⑧
 - Idle gear ⑦
 - O-ring ⑥
 - Oil pump ⑤
 - Screws ④
 - Gasket ③
 - Cover ②
 - Bolts ①

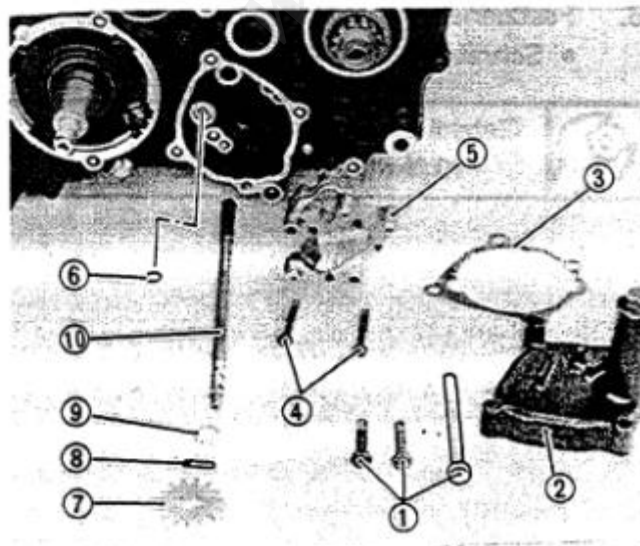

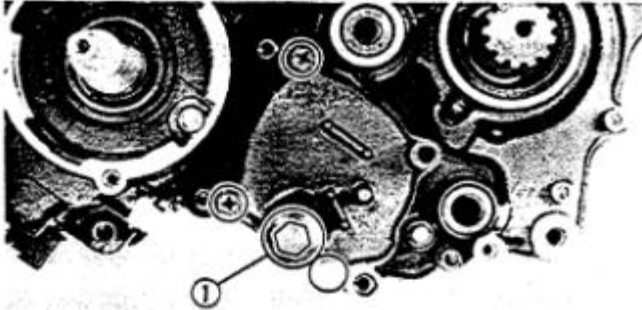

4. Tighten:
 - Screws
 - Bolts
 - Drain plug ①



Oil Pump Housing:
5 Nm (0.5 m·kg, 3.6 ft·lb)
Oil Pump Cover:
10 Nm (1.0 m·kg, 7.2 ft·lb)
Drain Plug:
22 Nm (2.2 m·kg, 16 ft·lb)

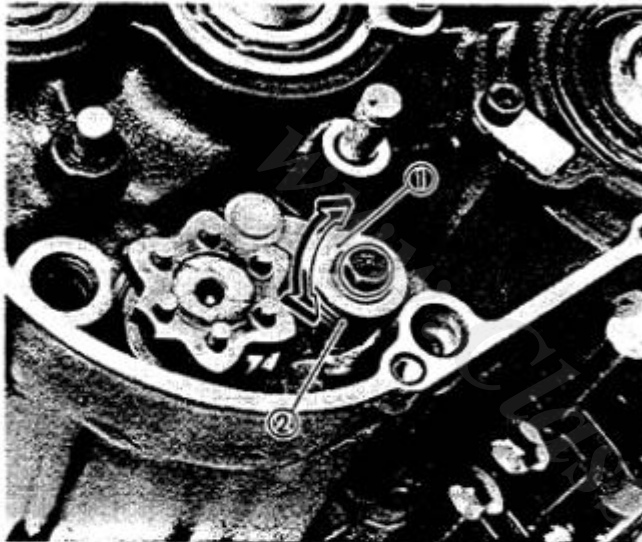

PRIMARY GEAR AND CHANGE SHAFT Change Shaft

1. Install:
 - Shift cam stopper lever ① with the return spring ②
2. Tighten:
 - Bolt (Shift cam stopper lever)



Stopper Lever:
10 Nm (1.0 m·kg, 7.2 ft·lb)
LOCTITE®

NOTE:
Check for smooth operation after tightening the stopper lever.

3. Install:
 - Change shaft

Primary Gear (Lower crankshaft)

1. Install:
 - Drive gear (Balancer gear) ①
 - Key ②
 - Primary gear ③
 - Zero lash gear ④
 - Plate washer ⑤
 - Conical washer ⑥
 - Drive gear (Water pump) ⑦
 - Conical washer ⑧
 - Nut ⑨

NOTE:
Install the conical washer with the concave side facing inward.

2. Finger tighten the nut ⑨.

NOTE:
Do not tighten the nut at this point.

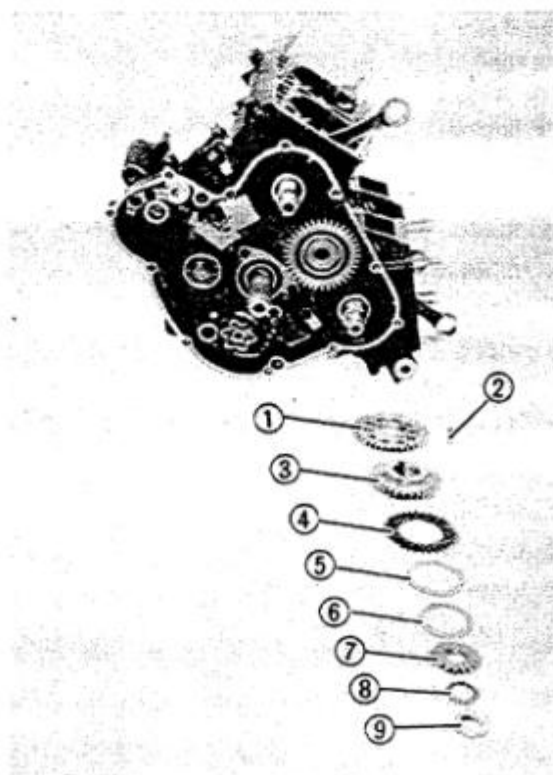

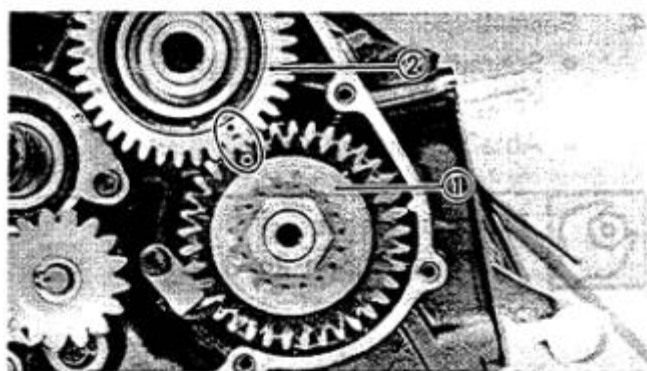

NOTE:
Make sure the punch mark on the drive gear ① aligns with the painted circle on the balancer gear ②.

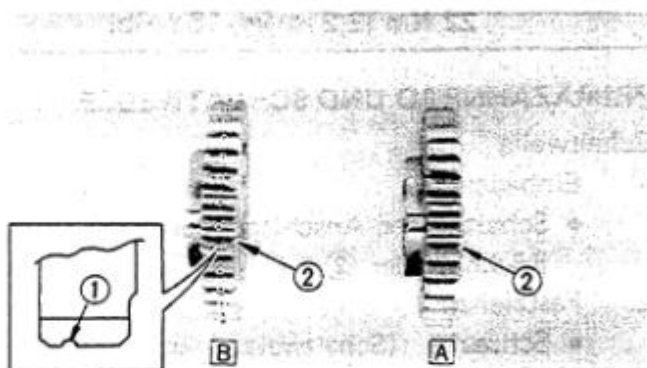

NOTE:
Make sure that the gear having discriminating cuts ① is installed on the lower crankshaft with the recessed surface ② facing outward.

A For upper crankshaft
B For lower crankshaft

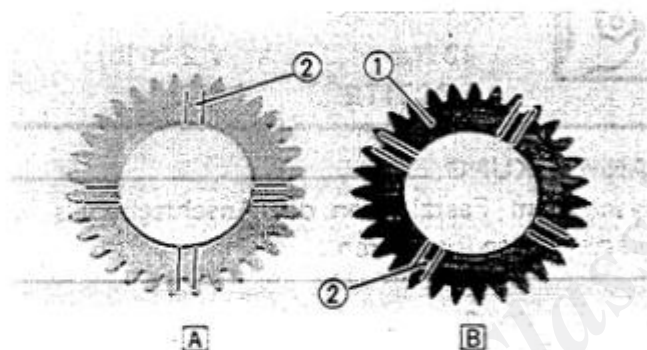

NOTE:
Make sure that the black coated gear ① is installed on the lower crankshaft with the recessed surface ② facing outward.

A For upper crankshaft
B For lower crankshaft

Primary Gear (Upper crankshaft)

1. Install:
 - Collar ①
 - Key ②
 - Primary gear ③
 - Zero lash gear ④
 - Plate washer ⑤
 - Conical washer ⑥
 - Collar ⑦
 - Conical washer ⑧
 - Nut ⑨

NOTE:
Install the conical washer with the concave side facing inward.

2. Finger tighten the nut ⑨.

NOTE:
Do not tighten the nut at this point.

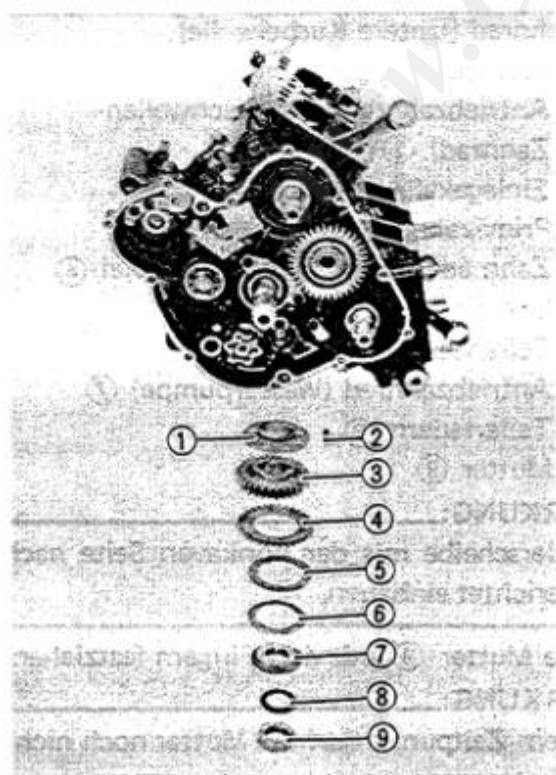



KICK GEAR AND PUMP GEAR

1. Install:

- Oil pump gear (Transmission oil) ④
- Oil pump gear (Engine oil) ③
- Kick idle gear ②
- Kick gear ①

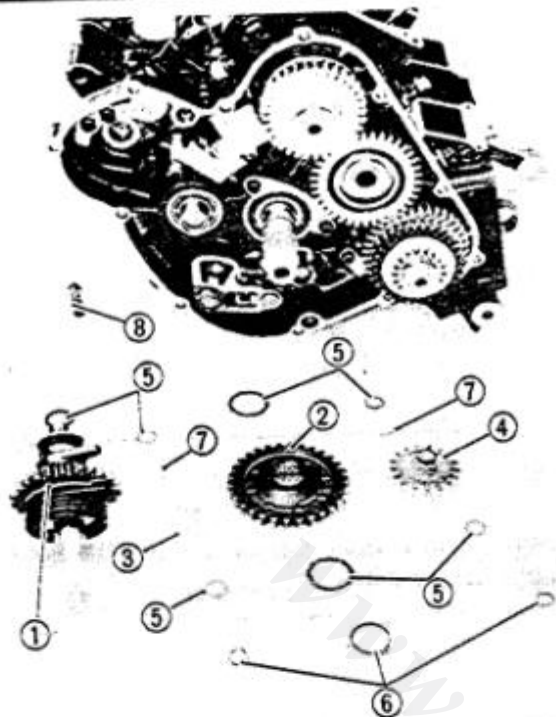

- ⑤ Washer
- ⑥ Circlip
- ⑦ Dowel pin
- ⑧ Oil pump drive shaft

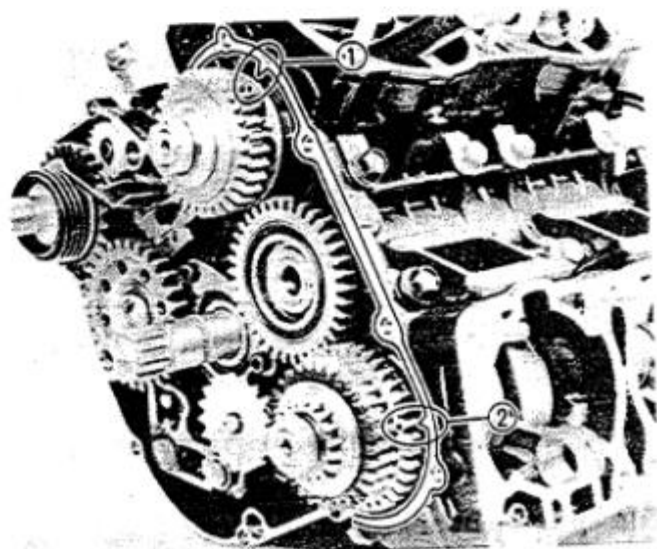
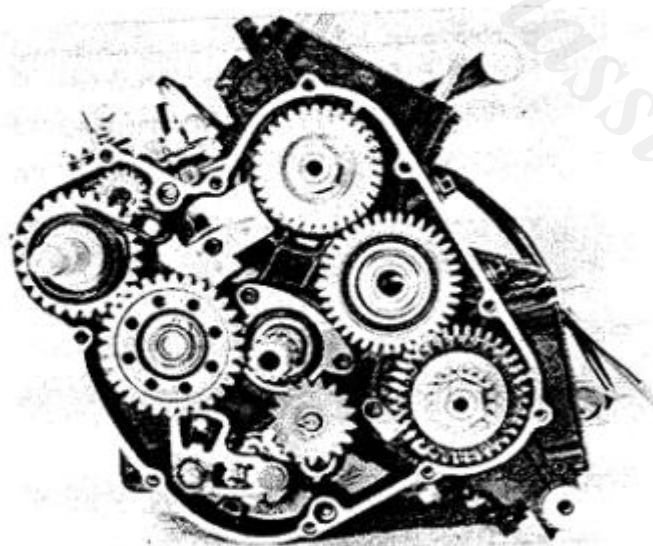

2. Align the punch marks on the collar ① and drive gear ② with the stationary pointers on the crankcase.

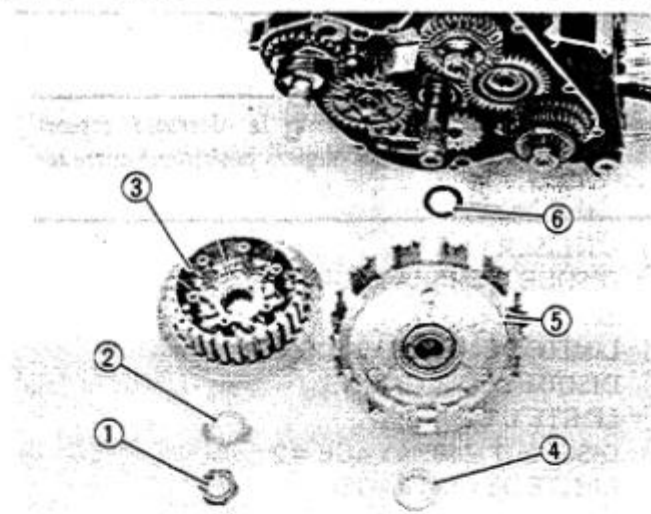

1. Install:
 - Plate washer (6)
 - Clutch housing (5)
 - Thrust washer (4)
 - Clutch boss (3)
 - Lock washer (2)
 - Clutch boss nut (1)
2. Turn the clutch housing clockwise a few turns to ensure that the main axle and crankshaft turns smoothly.

CAUTION:

Be sure the punch marks on the collar and drive gear are aligned with the stationary pointers on the crankcase.

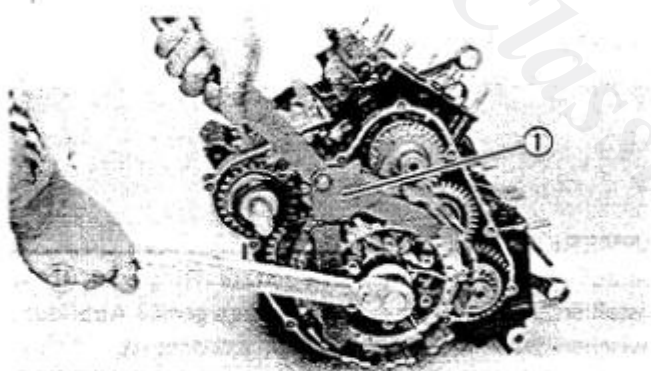

3. Attach:
 - Universal Clutch Holder (90890-04086) (1)
4. Tighten:
 - Clutch boss nut



Clutch Boss:
90 Nm (9.0 m·kg, 65 ft·lb)



5. Bend:
 - Lock washer tab (Clutch boss)
6. Place a piece of rolled rag (1) or piece of lead between the primary gears, and tighten the primary gear securing nuts.



Primary Gear:
85 Nm (8.5 m·kg, 61 ft·lb)

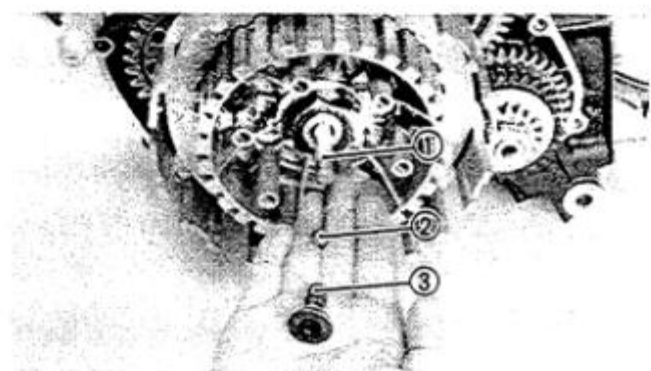

7. Install:
 - Push rod No. 2 (1)
 - Ball (2)
 - Push rod No. 1 (3) (With new O-ring)

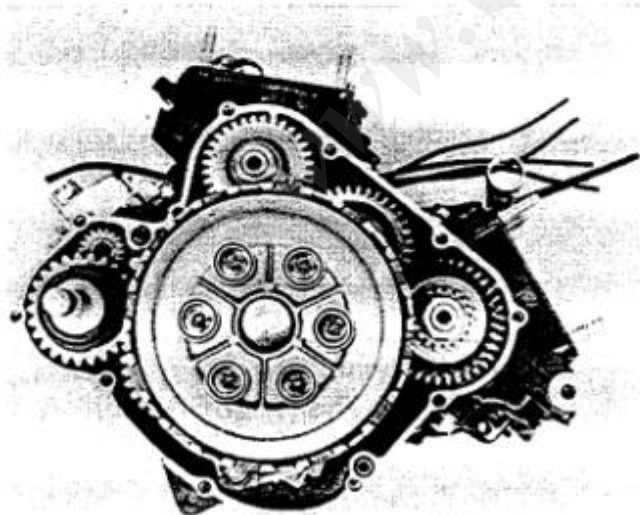
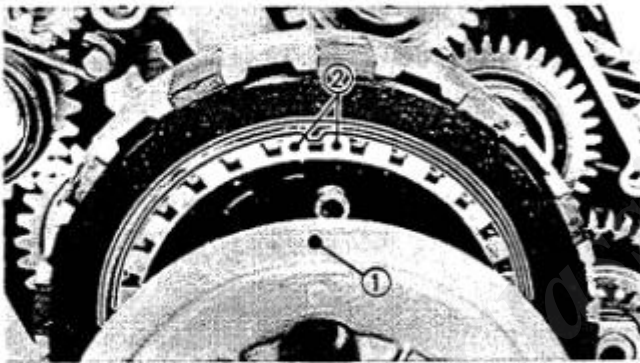
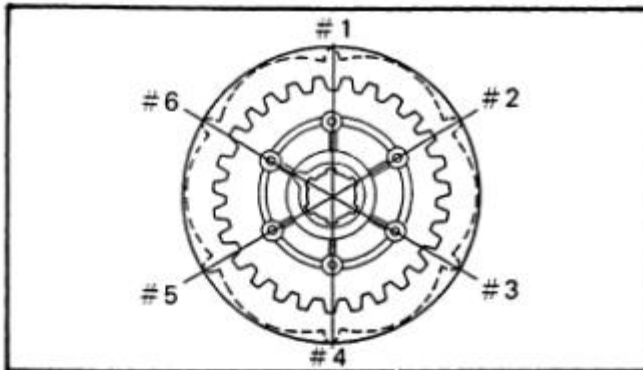

8. Install:
- Ring-springs
 - Friction plates
 - Clutch plates

NOTE: _____

- Mount friction and clutch plates alternately.
- Install the clutch plates as shown, with the mild edge outward.

NOTE: _____

Make sure that the last ring spring (1) only is installed with any one of its tabs positioned between the rounded marks (2) as shown.

9. Install:
- Pressure plate
 - Clutch springs
 - Clutch spring bolts

NOTE: _____

- When installing the clutch pressure plate, align the marks on the clutch boss (1) and pressure plate (2).
- Fit the clutch boss splines into the pressure plate splines.

10. Tighten:
- Clutch spring bolts



Clutch Spring:
8 Nm (0.8 m·kg, 5.8 ft·lb)

CRANKCASE COVER AND WATER PUMP

1. Install:
- Dowel pins
 - Gasket
 - Crankcase cover
 - Clamp
 - Delivery pipe (With new O-ring)

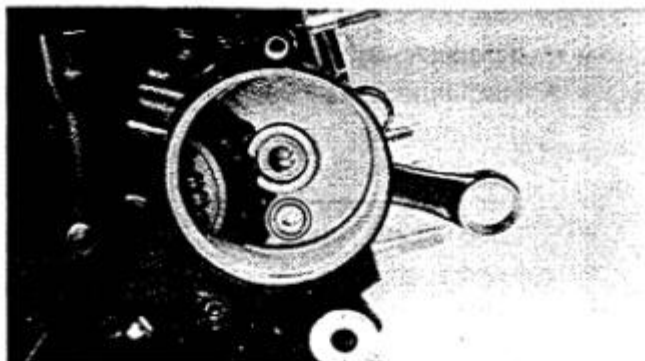

2. Tighten:
 - Bolts
 - Union bolt



Crankcase Cover:
 10 Nm (1.0 m·kg, 7.2 ft·lb)
Delivery Pipe:
 10 Nm (1.0 m·kg, 7.2 ft·lb)

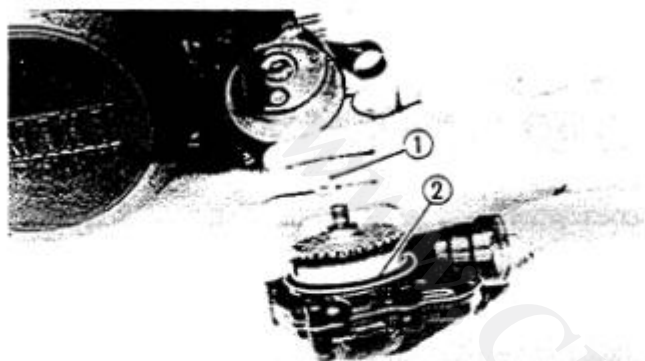

3. Install:
 - Washer ①
 - Water pump (With new O-ring) ②
4. Tighten:
 - Bolts



Water Pump:
 10 Nm (1.0 m·kg, 7.2 ft·lb)

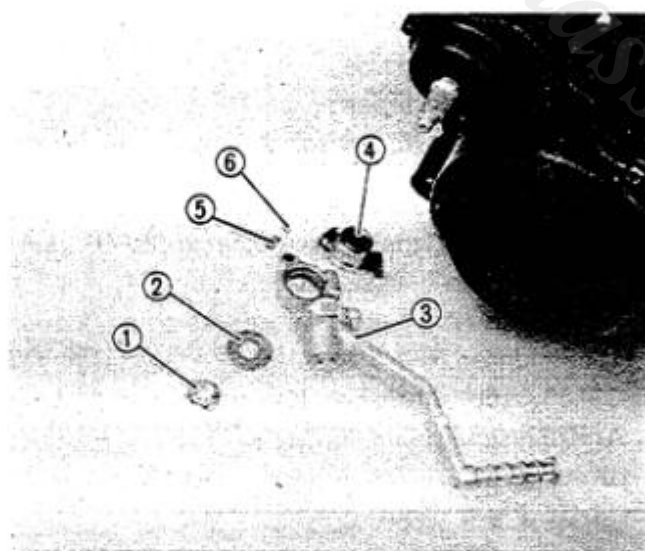

5. Apply grease to the collar ④.
6. Assemble:
 - Spring ⑤
 - Ball ⑥
(into the kick crank)
7. Install:
 - Kick crank ③
 - Washer ②
 - Nut ①
8. Tighten:
 - Nut



Kick Crank:
 65 Nm (6.5 m·kg, 47 ft·lb)

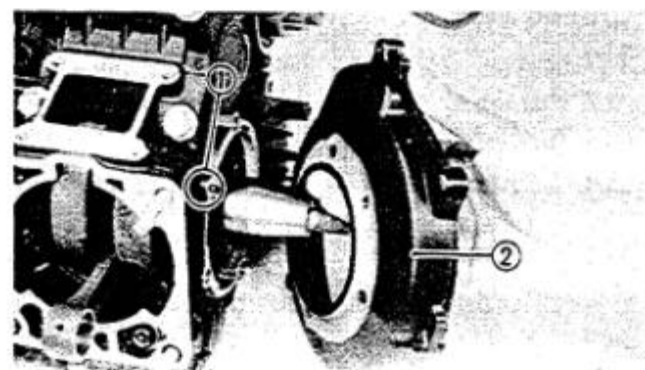

OIL PUMP (ENGINE OIL) AND FLYWHEEL

1. Install:
 - Dowel pin ①
 - Flywheel housing ②
 - Bolts



Flywheel Housing:
 10 Nm (1.0 m·kg, 7.2 ft·lb)

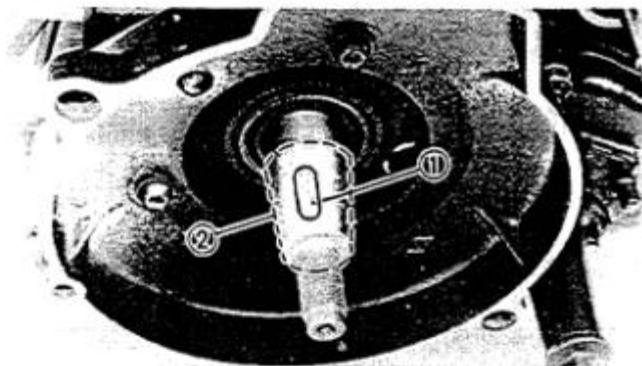

2. Install:
 - Key ①
 - Flywheel
 - Washers
 - Nut

CAUTION:

Be sure to remove any oil and/or grease from the tapered portion of the crankshaft ② and flywheel with a thinner.

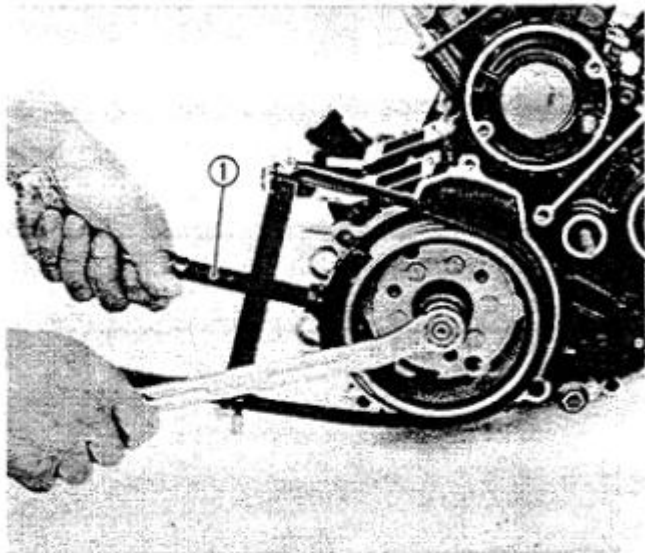

3. Attach:
 - Universal Sheave Holder (90890-01701) ①
4. Tighten:
 - Nut



Flywheel:
80 Nm (8.0 m·kg, 58 ft·lb)

5. Install:
 - Oil pump (Engine oil)
(With a new O-ring)
6. Tighten:
 - Bolt



Oil Pump:
10 Nm (1.0 m·kg, 7.2 ft·lb)
LOCTITE®

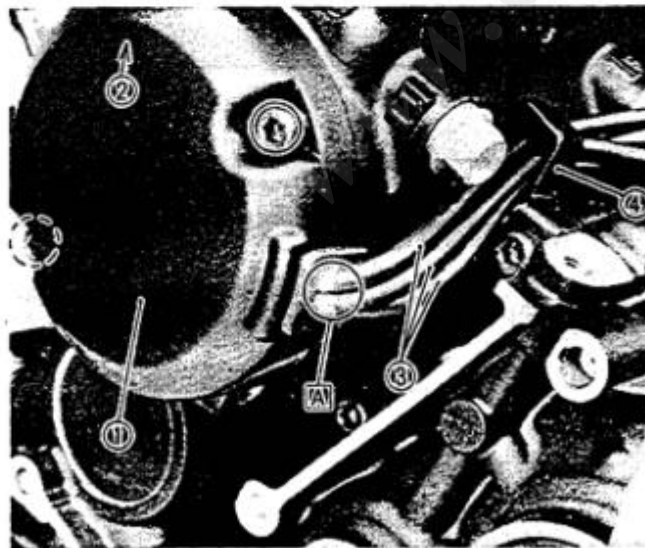

7. Install:
 - Crankshaft end cover ①

NOTE:

The arrow mark ② on the cover should face upward.

- ③ Delivery hose
- ④ Clamp
- Ⓐ White paint mark



CYLINDER HEAD, CYLINDER AND YPVS

- 1. Clamp (YPVS Cables)
 - 2. Cylinder head gasket (Marked "1" for upper cylinder and marked face up)
 - 3. Cylinder
 - 4. Cylinder gasket (Bonded face up)
 - 5. Oil seal
 - 6. YPVS holder
 - 7. O-ring
 - 8. Power valve
 - 9. YPVS pulley
 - 10. YPVS arm (Marked "1" for upper cylinder)
 - 11. YPVS arm (Marked "2" for lower cylinder)
 - 12. YPVS joint holder
 - 13. YPVS cable "2" (Black color cap)
 - 14. YPVS cable "1"
- * Use the cap nut with a copper washer

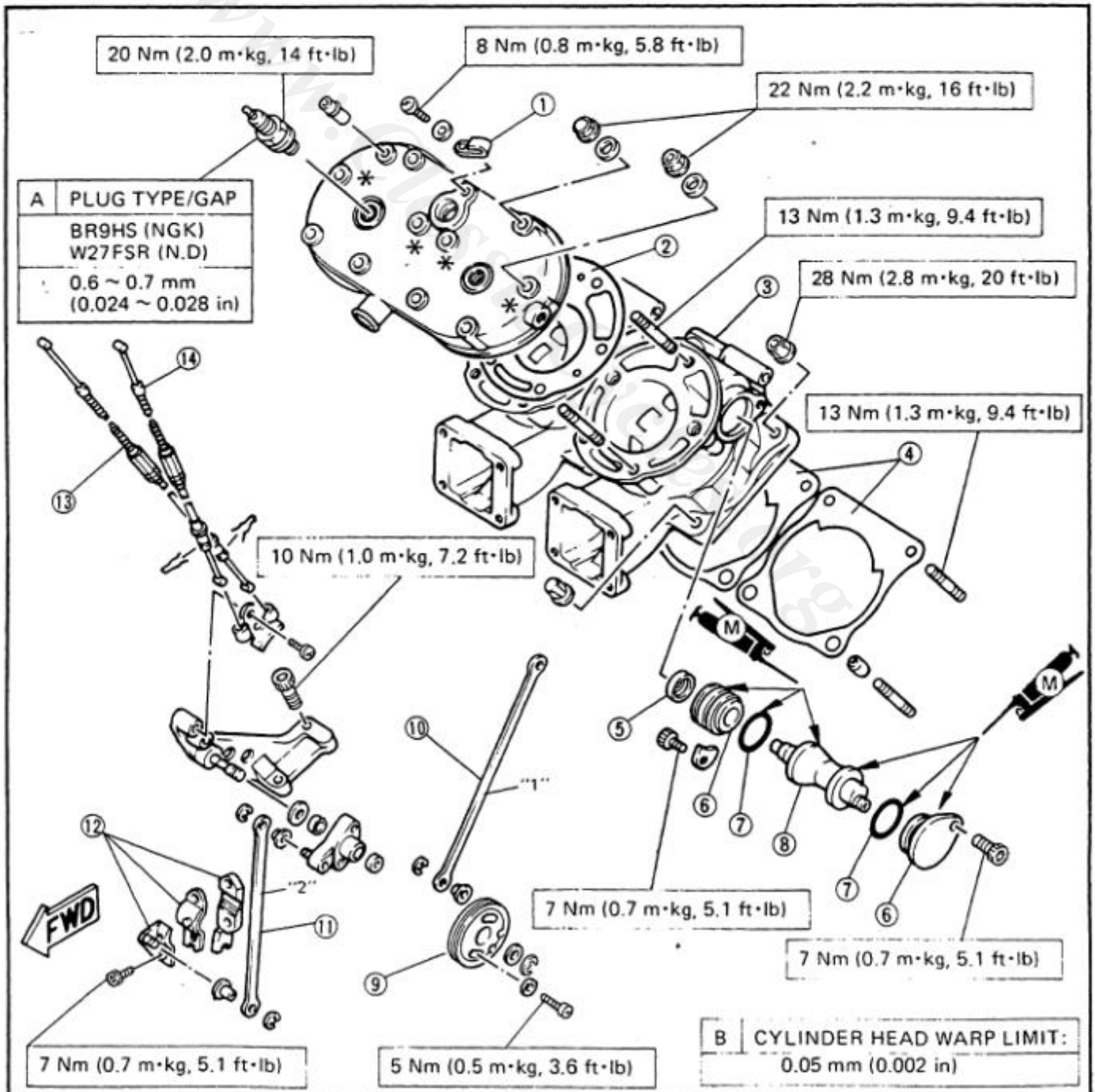

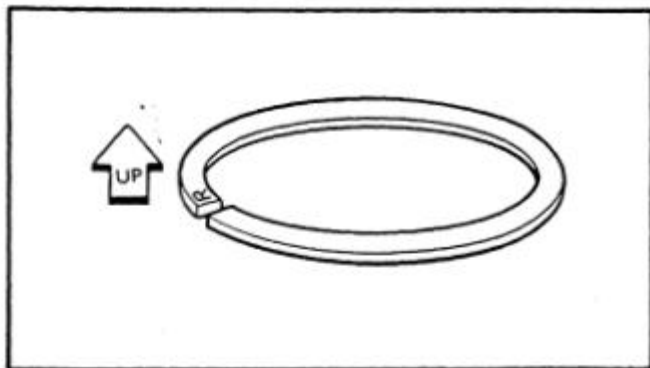

PISTON AND CYLINDER (LOWER)

1. Install:
 - Piston rings
(onto the pistons)

NOTE: _____
 Be sure to install the rings so that Manufacturer's marks or numbers are located on the top side of the rings. Oil the pistons and rings liberally.

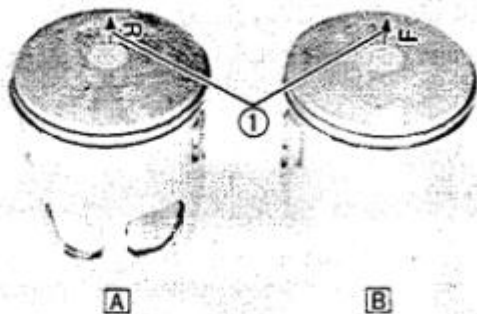

2. Install:
 - Pistons

NOTE: _____
 • Be sure the pistons are positioned correctly.
 • Always install new piston pin clips.
 • The arrow mark ① on the piston should face toward the exhaust side.

A FOR UPPER CYLINDERS
B FOR LOWER CYLINDERS

3. Oil liberally:
 - Pistons
 - Rings
 - Connecting rod bearings
 - Cylinders
4. Set:
 - Piston ring ends

NOTE: _____
 Make sure the rings are properly positioned.

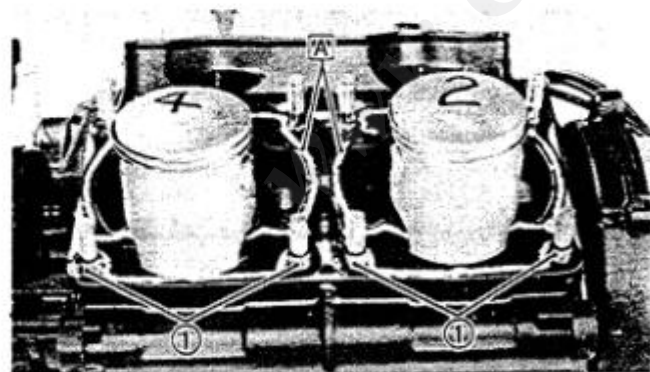

5. Install:
 - Dowel pins ①
 - Gaskets (New)
 - Cylinders

A BONDED FACE UP

6. Tighten:
 - Cylinder nuts

	<p>Cylinder Nut: 28 Nm (2.8 m·kg, 20 ft·lb)</p>
--	---

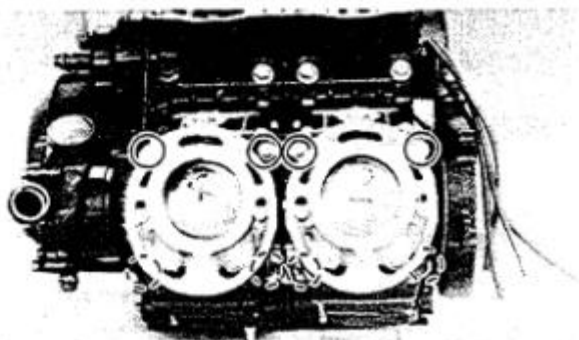

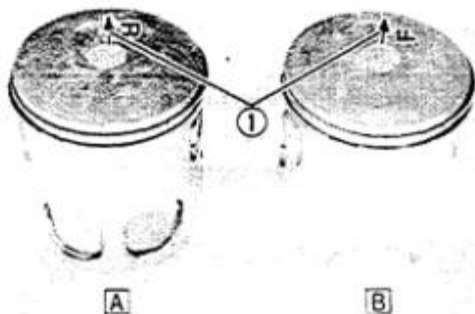
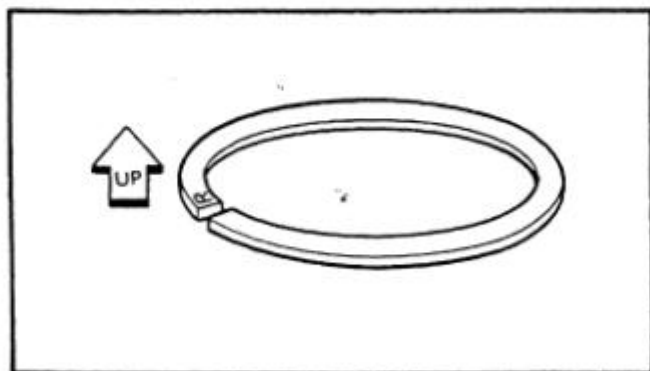
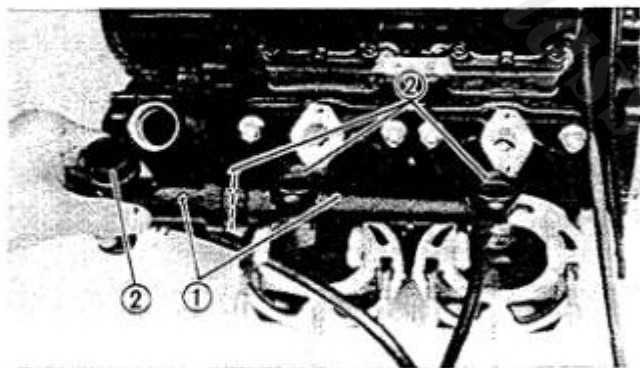
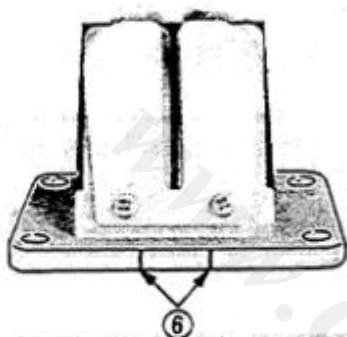
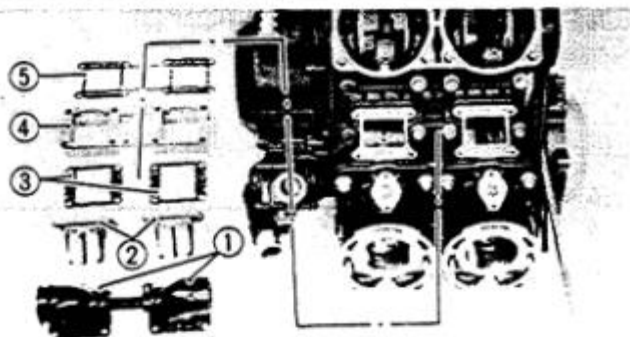

REED VALVE AND WATER JACKET (LOWER)

Reed Valve:

1. Install:
 - Gasket (New) ⑤
 - Housing ④
 - Gaskets ③
 - Reed valves ②
 - Carburetor joint ①

NOTE:

When installing the reed valves, their identification slots ⑥ should face the cylinder head side.

2. Tighten:
 - Bolts



Carburetor Joint:

10 Nm (1.0 m·kg, 7.2 ft·lb)

3. Connect:
 - Engine oil delivery hoses

Water Jacket

1. Install:
 - O-rings (New) ②
 - Water jackets ①
2. Tighten:
 - Bolts



Water Jacket:

10 Nm (1.0 m·kg, 7.2 ft·lb)

PISTON AND CYLINDER (UPPER)

1. Install:
 - Piston rings
(onto the pistons)

NOTE:

Be sure to install the rings so that Manufacturer's marks or numbers are located on the top side of the rings. Oil the pistons and rings liberally.

2. Install:
 - Pistons

NOTE:

- Be sure the pistons are positioned correctly.
- Always install new piston pin clips.
- The arrow mark ① on the piston should face toward the exhaust side.

A FOR UPPER CYLINDERS

B FOR LOWER CYLINDERS

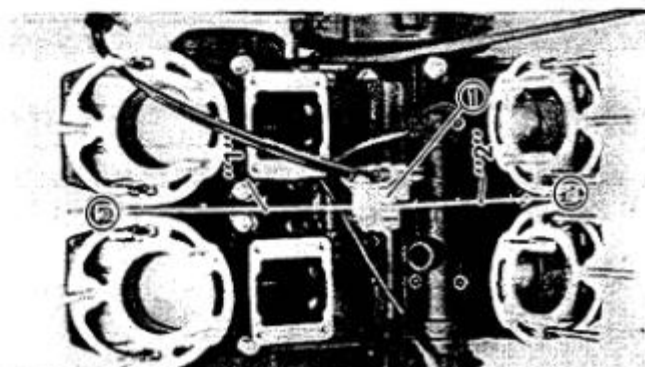
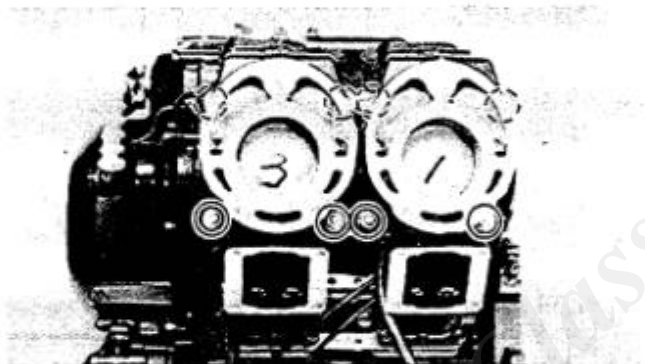
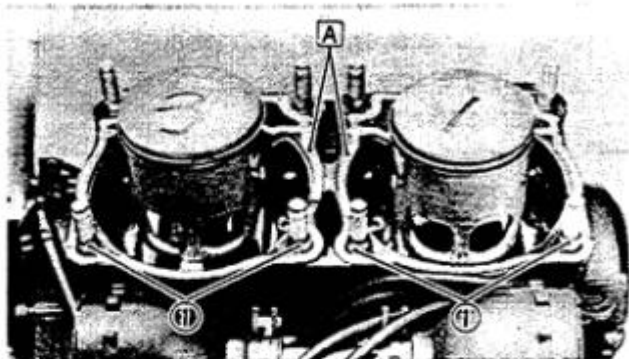
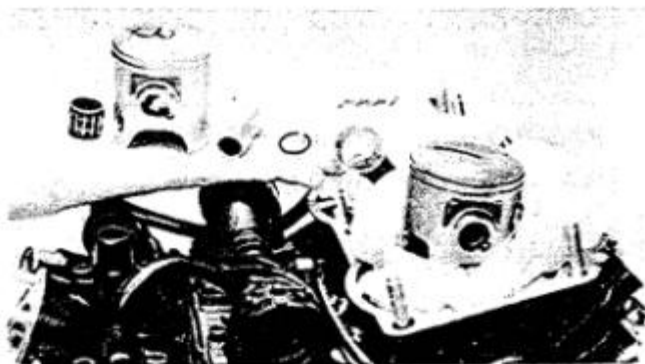

3. Oil liberally:
 - Pistons
 - Rings
 - Connecting rod bearings
 - Cylinders
4. Set:
 - Piston ring ends

NOTE: _____
 Make sure the rings are properly positioned.

5. Install:
 - Dowel pins ①
 - Gaskets (New)
 - Cylinders

A BONDED FACE UP

6. Tighten:
 - Cylinder nuts



Cylinder Nut:
 28 Nm (2.8 m·kg, 20 ft·lb)

YPVS LINK AND REED VALVE (UPPER)

1. Install:
 - YPVS joints ①
2. Tighten:
 - Bolts



YPVS Joint:
 7 Nm (0.7 m·kg, 5.1 ft·lb)

3. Install:
 - YPVS pulley bracket ①
 - YPVS links
4. Tighten:
 - Bolts



YPVS Pulley:
 7 Nm (0.7 m·kg, 5.1 ft·lb)
YPVS Link:
 7 Nm (0.7 m·kg, 5.1 ft·lb)

"1" For upper cylinders
 "2" For lower cylinders

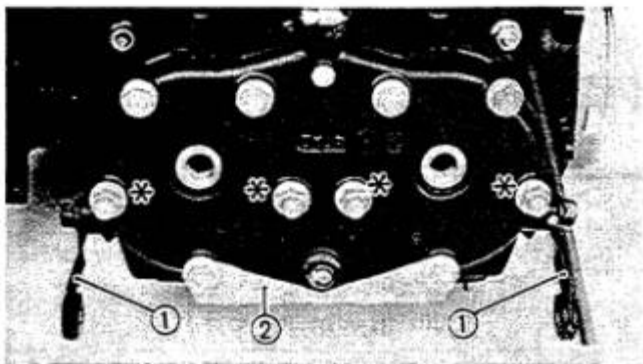
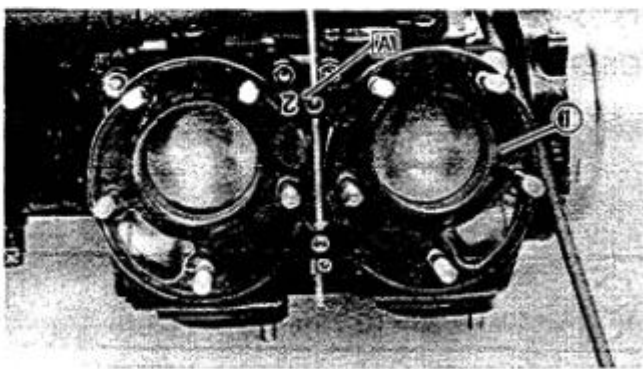
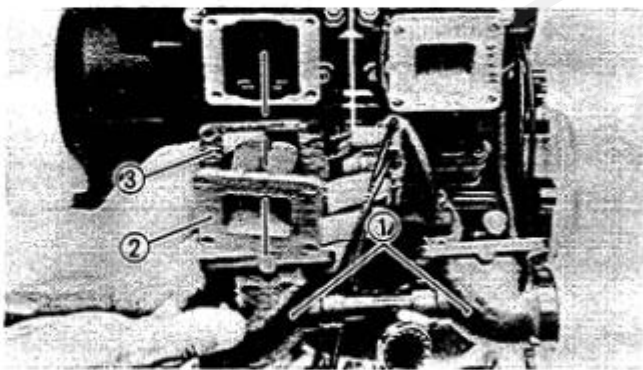
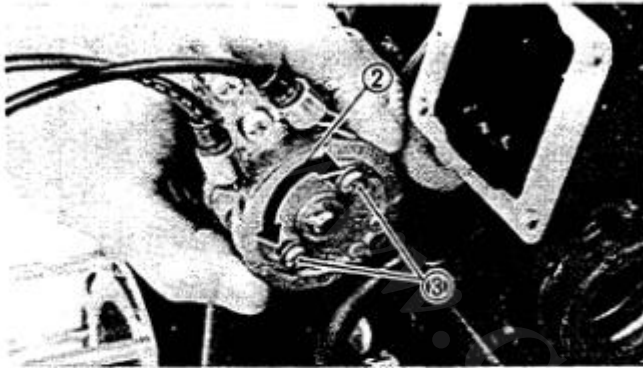
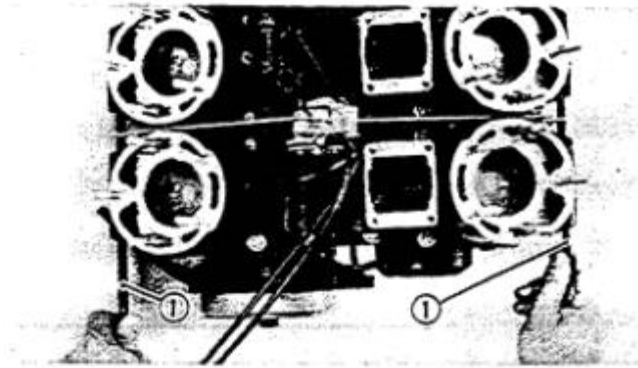

5. Adjust:
 - YPVS link

YPVS link adjustment steps:

- Loosen the YPVS pulley securing screws.
- Insert the 8 mm dia. bolts (i.e. engine mounting bolts ①) to hold each of the YPVS's.
- Turn the YPVS pulley ② until it stops completely and while holding the pulley, tighten the screws ③.



YPVS Pulley:

5 Nm (0.5 m·kg, 3.6 ft·lb)

6. Install:
 - Gaskets (New) ③
 - Reed valves ②
 - Carburetor joints ①
7. Connect:
 - Engine oil delivery hoses

CYLINDER HEAD AND CARBURETOR (RIGHT)

Cylinder Head (Lower)

1. Install:
 - Cylinder head gasket (New) ①

A Marked "2" for lower cylinder and marked face up

2. Install:
 - Cylinder head
 - Stay ①
 - Engine guard ②
 - Washers
 - Cylinder head nuts

* Cap nut with a copper washer

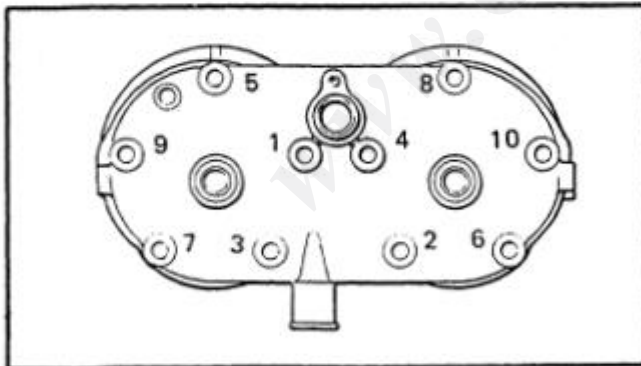
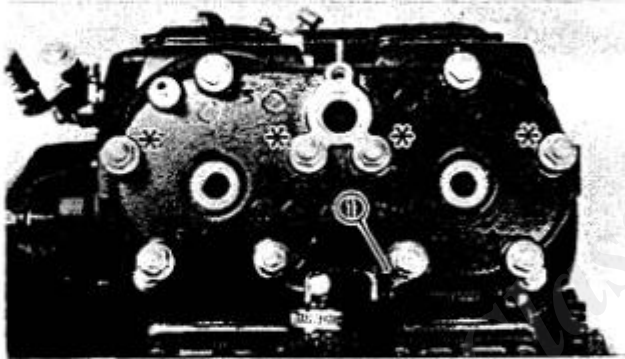
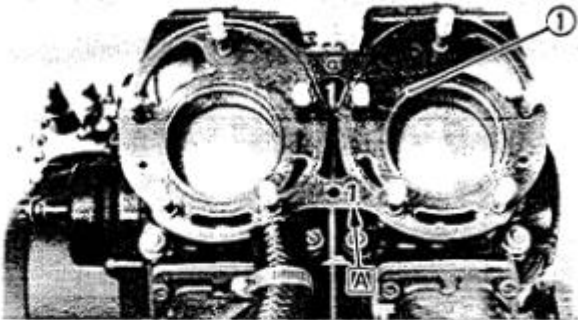
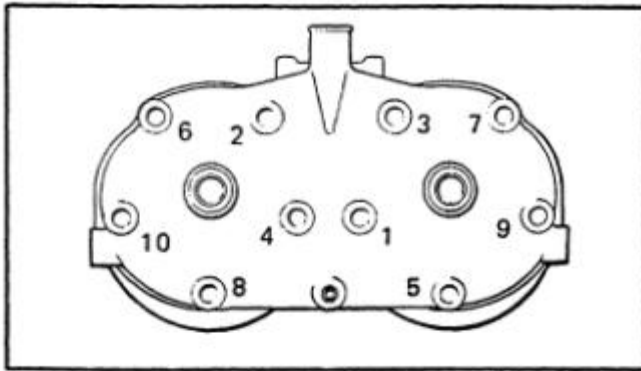

3. Tighten:
 - Cylinder head nuts



Cylinder Head:
22 Nm (2.2 m·kg, 16 ft·lb)

NOTE:

The embossed numbers in the cylinder head designate the cylinder head tightening sequence.

Cylinder Head (Upper)

1. Install:
 - Cylinder head gasket (New) ①

Ⓐ Marked "1" for upper cylinder and marked face up

2. Install:
 - Cylinder head
 - Bracket ①
 - Washers
 - Cylinder head nuts

* Cap nut with a copper washer

3. Tighten:
 - Cylinder head nuts



Cylinder Head:
22 Nm (2.2 m·kg, 16 ft·lb)

NOTE:

The embossed numbers in the cylinder head designate the cylinder head tightening sequence.

Carburetor (Right)

1. Connect:
 - Hoses
2. Install:
 - Clamp screws ①



3. Install:
 - Carburetors (Right) ②
4. Tighten:
 - Clamp screws ①

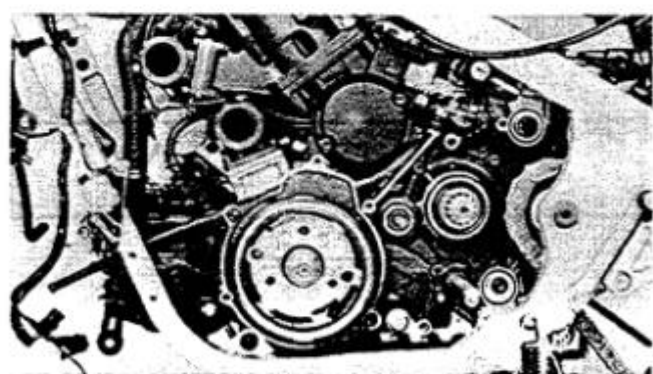

REMounting ENGINE

1. Refer to engine removal. Reverse those removal steps that apply.
2. Install:
 - Downtube frame
3. Tighten:
 - Engine mount bolts

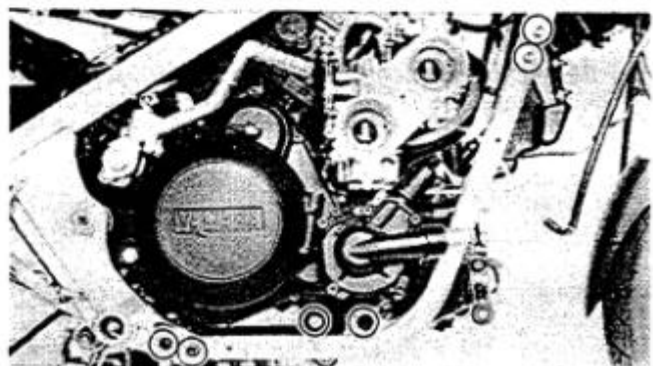

- Engine Mount (Front Lower):
32 Nm (3.2 m·kg, 23 ft·lb)
- Engine Mount (Rear Upper):
32 Nm (3.2 m·kg, 23 ft·lb)
- Engine Mount (Rear Lower):
32 Nm (3.2 m·kg, 23 ft·lb)
- Tensionbar – Engine:
23 Nm (2.3 m·kg, 17 ft·lb)
- Downtube frame:
32 Nm (3.2 m·kg, 23 ft·lb)

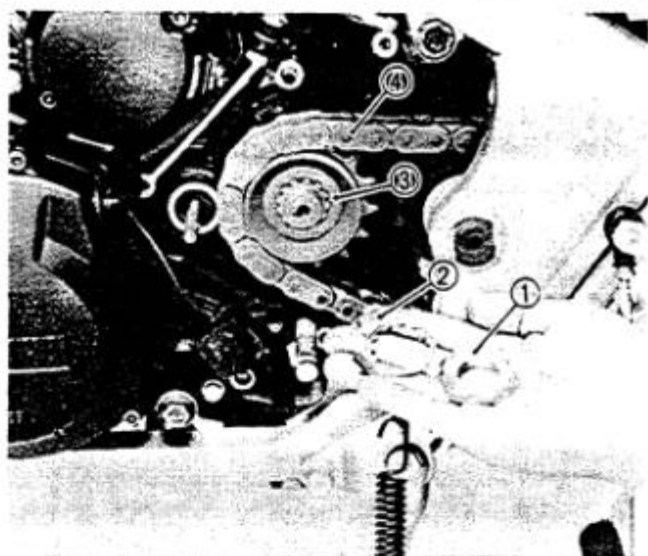

Drive Chain and Crankcase Cover (Left)

1. Connect:
 - Neutral switch lead
2. Install:
 - Generator cover
 - Drive sprocket ③ with drive chain ④
 - Lock washer (New) ②
 - Sprocket securing nut ①
3. Tighten:
 - Generator cover
 - Nut



Generator Cover:
10 Nm (1.0 m·kg, 7.2 ft·lb)
Drive Sprocket:
90 Nm (9.0 m·kg, 65 ft·lb)

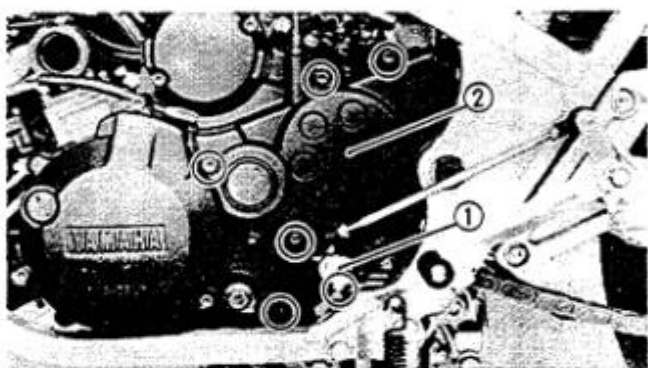

4. Install:
 - Dowel pins
 - Crankcase cover (Left) ②
 - Change pedal arm securing bolt ①
5. Tighten:
 - Bolts



Crankcase Cover (Left):
10 Nm (1.0 m·kg, 7.2 ft·lb)
Change Pedal Arm:
10 Nm (1.0 m·kg, 7.2 ft·lb)

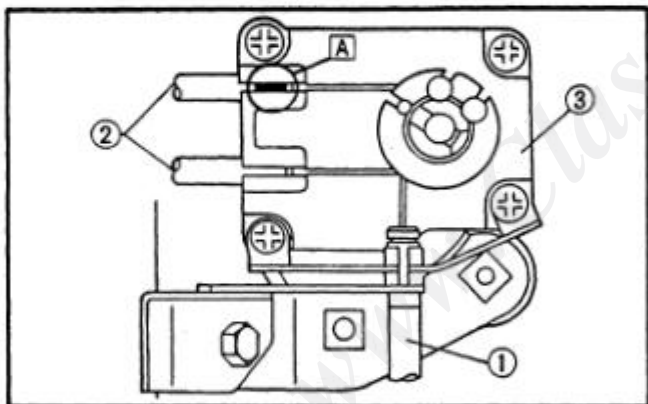

CONNECTOR AND CABLE

1. Connect:
 - Oil pump cable ①
 - YPVS cables ②
 2. Install:
 - Circlip (Oil pump cable)
 - Servomotor cover
- ③ Servomotor
A Black color cap
3. Install:
 - Thermostat housing assembly (With a new O-ring)
 4. Tighten:
 - Bolt (Thermostat housing assembly)



Thermostat Housing:
8 Nm (0.8 m·kg, 5.8 ft·lb)



5. Connect:
 - Spark plug lead
 - Thermo switch lead
 - Thermo unit lead



6. Connect:
 - Throttle cables ①

WARNING:

- See CHAPTER 8 "Cable Routing" for proper cable, lead, and hose routing.
- Make sure that the cables are not twisted.
- Be careful not to pinch the leads.

A Cable protector

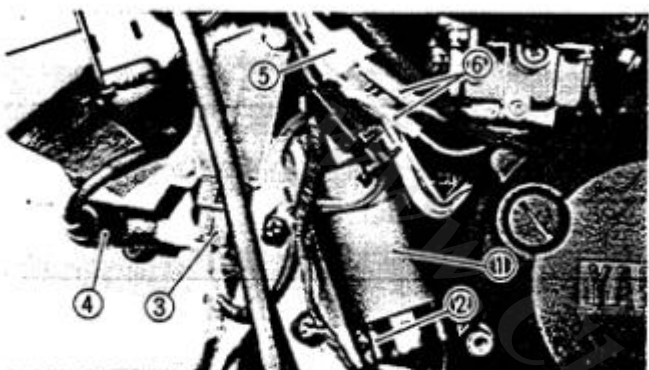

7. Install:
 - Ignition coil (Lower cylinder) ①
8. Connect:
 - Ignition coil lead ②
 - Rectifier/regulator lead ③
 - Spark plug lead ④
 - Generator lead ⑤
 - Pickup coil lead ⑥

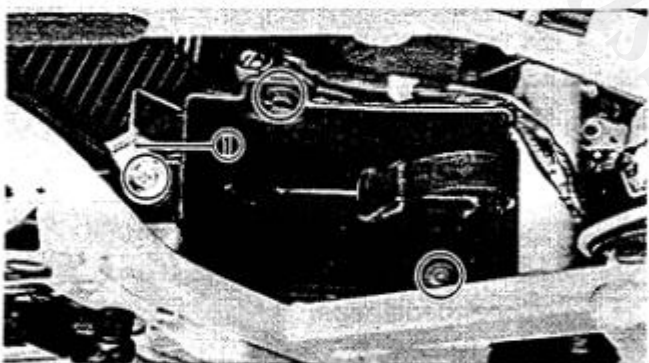
**MUFFLER**

1. Install:
 - Battery box
 - Mufflers (With new gaskets)



① Clamp

2. Install:
 - Mufflers
3. Tighten:
 - Mufflers

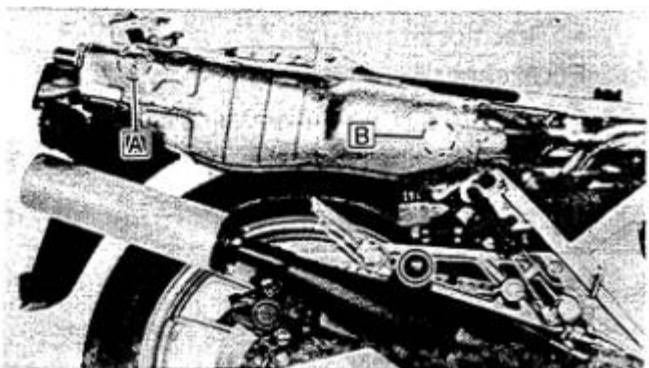
**Muffler – Cylinder:**

22 Nm (2.2 m·kg, 16 ft·lb)

Muffler – Frame:

16 Nm (1.6 m·kg, 11 ft·lb)

Muffler – Muffler Bracket:

25 Nm (2.5 m·kg, 18 ft·lb)

A Shorter bolt

B Longer bolt

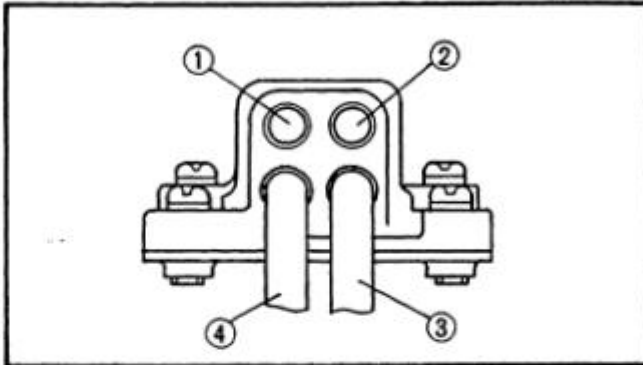
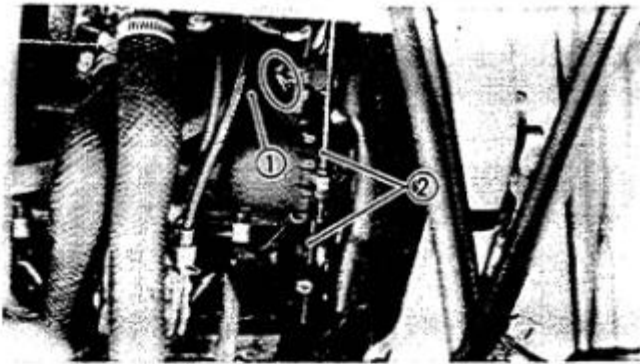
**CARBURETOR (LEFT)**

1. Install:
 - Carburetors (Left)
2. Tighten:
 - Clamp screws ②
3. Connect:
 - Fuel hose ①
4. Assemble:
 - Choke lever

- ① To right lower carburetor
 ② To right upper carburetor
 ③ To left lower carburetor
 ④ To left upper carburetor

RADIATOR

1. Install:
 - Radiator
2. Tighten:
 - Bolts



Radiator:

7 Nm (0.7 m·kg, 5.1 ft·lb)

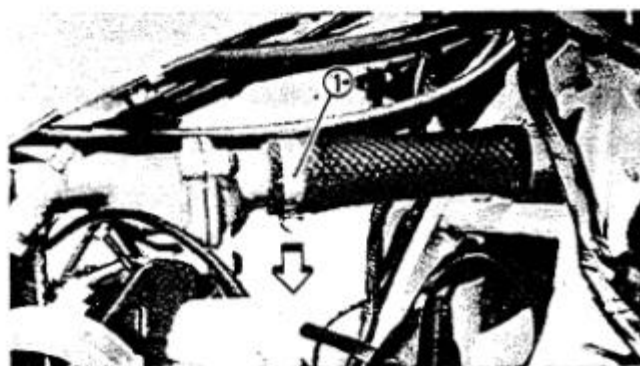
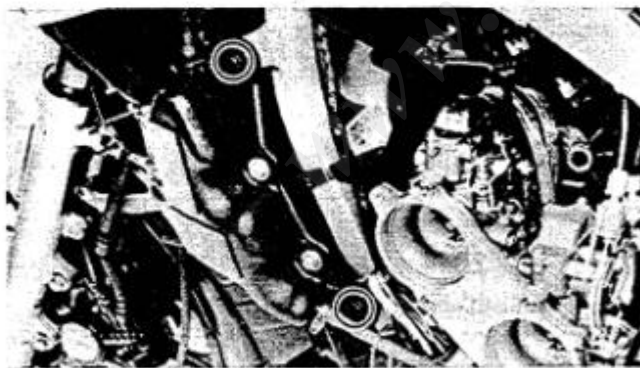
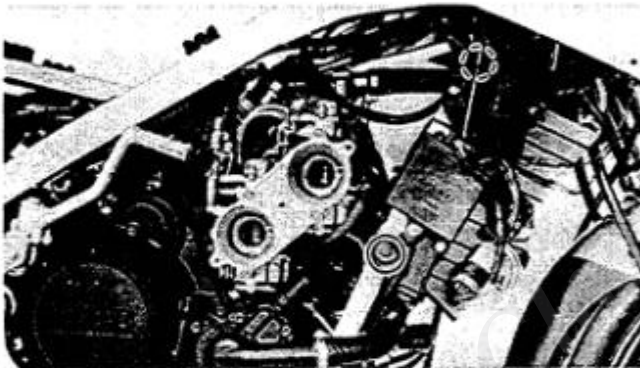

3. Connect:
 - Radiator hose (Inlet)
 - Radiator hose (Outlet)
 - Bypass hoses
 - Electric fan motor lead
4. Tighten:
 - Clamp ①



AIR FILTER

1. Install:
 - Air filter box
 - Air ducts ①

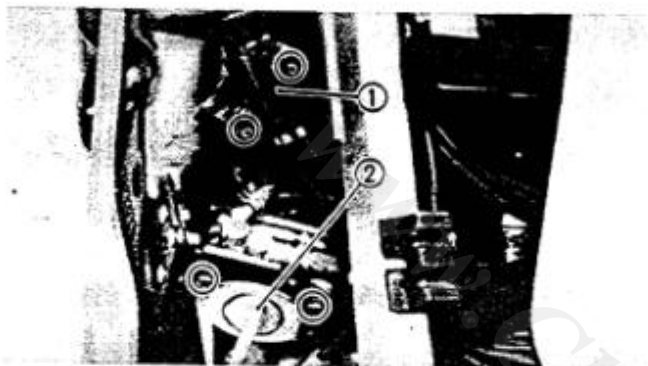

2. Install:
 - Fuel tank
 - Choke lever ①
 - Fuel cock ②



BATTERY AND COWLING

1. Install:
 - Battery
2. Connect:
 - Battery leads

NOTE:

Connect the positive lead first.



3. Install:
 - Battery cover
 - Fuse holder ①
 - Side cover

A CORRECT

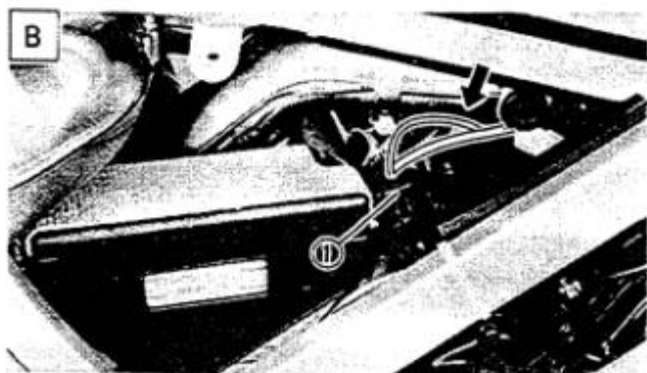

B INCORRECT

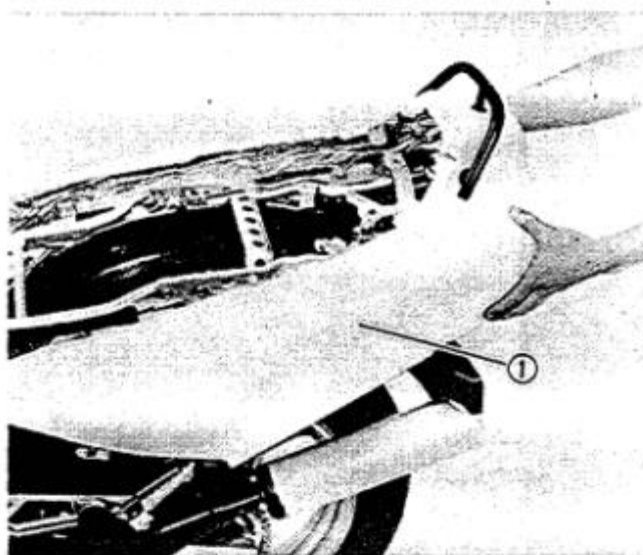

4. Install:
 - Rear cowling assembly ①
 - Center cowling
 Refer to CHAPTER 2, "COWLING".
5. Adjust:
 - YPVS cables
 - Oil pump cable
 - Clutch cable
 - Throttle cables
 - Drive chain
 Refer to CHAPTER 2, "PERIODIC INSPECTIONS AND ADJUSTMENTS".

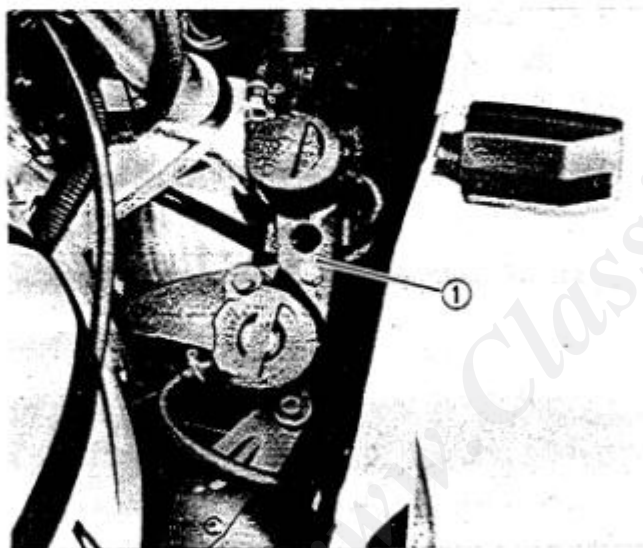

6. Add:
 - Coolant
 - Engine oil
 - Transmission oil

**Coolant:**

1.95 L (1.72 Imp qt, 2.06 US qt)

Engine Oil:

2.0 L (1.8 Imp qt, 2.1 US qt)

Transmission Oil:

1.6 L (1.4 Imp qt, 1.7 US qt)

7. Install:
 - Cap retainer ①
 - Heat protector
 - Lower cowling
 - Engine grille

CHAPTER 4. COOLING SYSTEM

COOLANT FLOW.....	4-1
COOLANT REPLACEMENT	4-3
WATER PUMP	4-3
DISASSEMBLY	4-3
INSPECTION	4-5
ASSEMBLY	4-5
INSTALLATION	4-5
THERMOSTATIC VALVE	4-5
REMOVAL	4-7
INSPECTION AND ASSEMBLY.....	4-7
RADIATOR	4-9
DISASSEMBLY	4-9
INSPECTION	4-9
ASSEMBLY	4-11
COOLANT FILLING	4-13

www.ClassicCycles.org



COOLING SYSTEM

COOLANT FLOW

- | | |
|-----------------|-----------------------|
| 1. Radiator cap | 6. Bypass hose |
| 2. Radiator | 7. Thermostat housing |
| 3. Outlet hose | 8. Thermostatic valve |
| 4. Water pump | 9. Inlet hose |
| 5. Water jacket | |

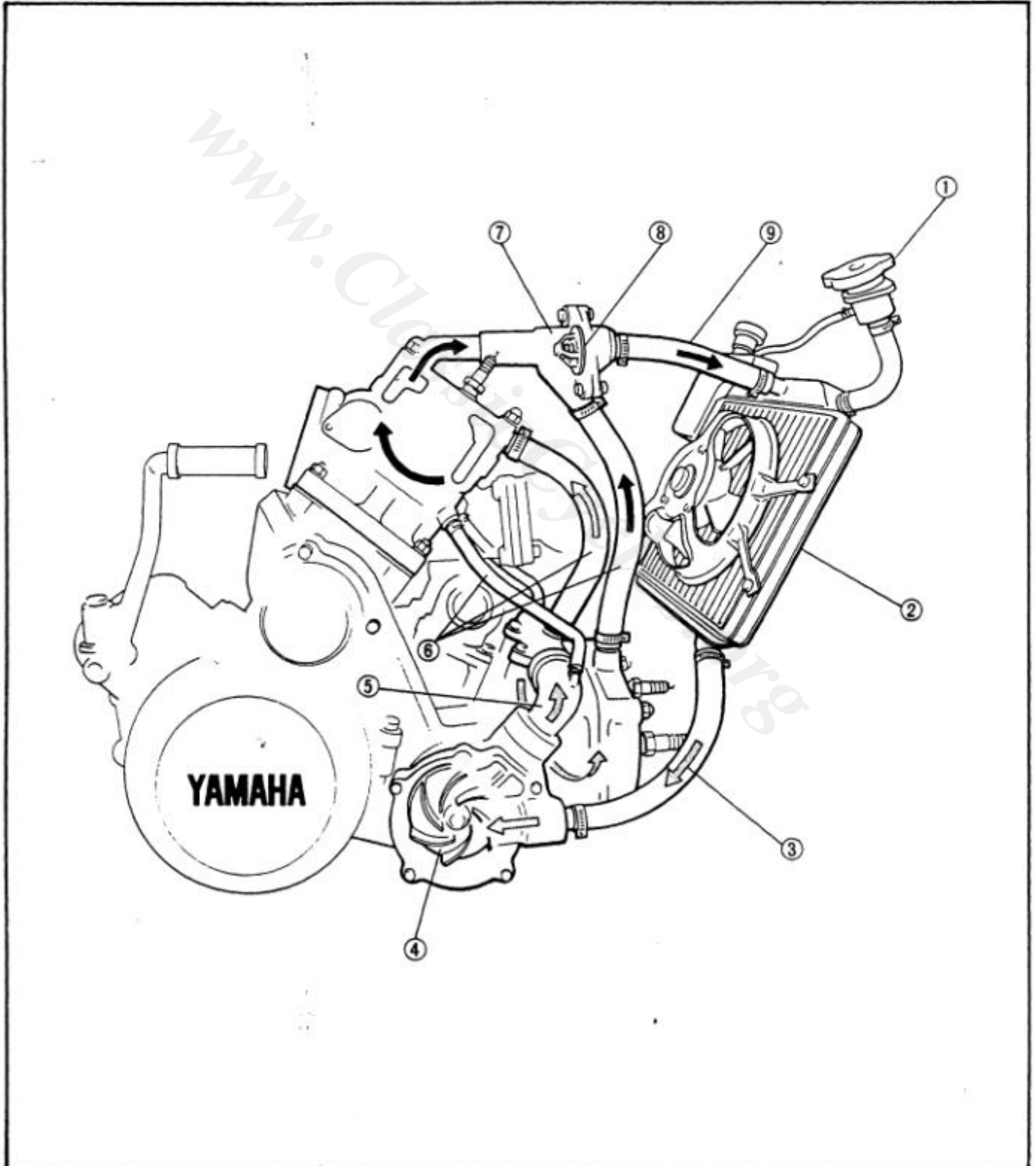

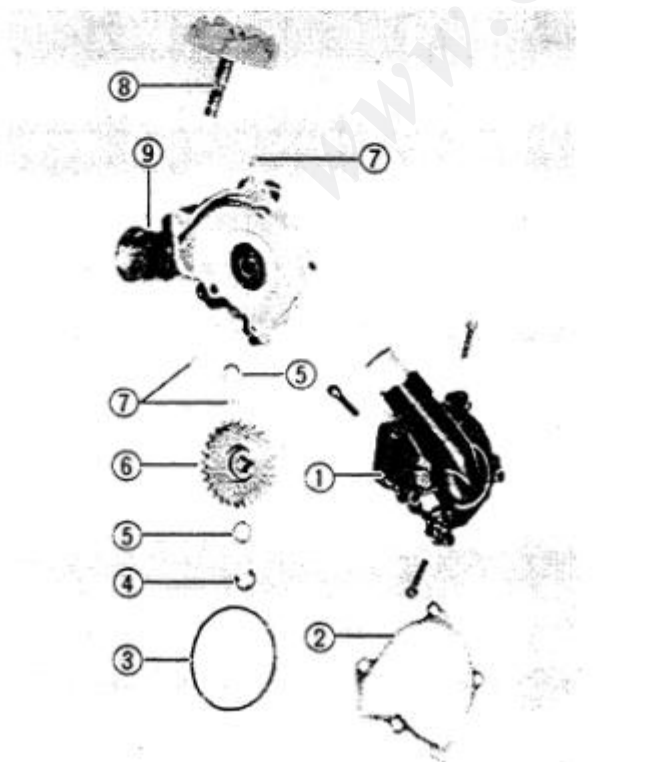
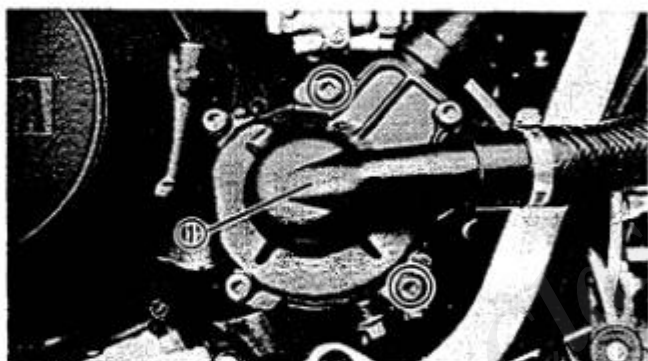
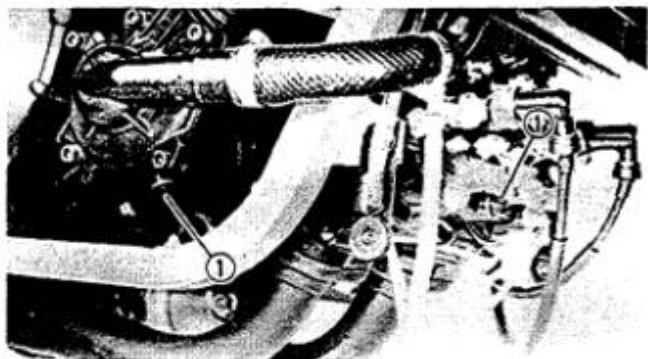
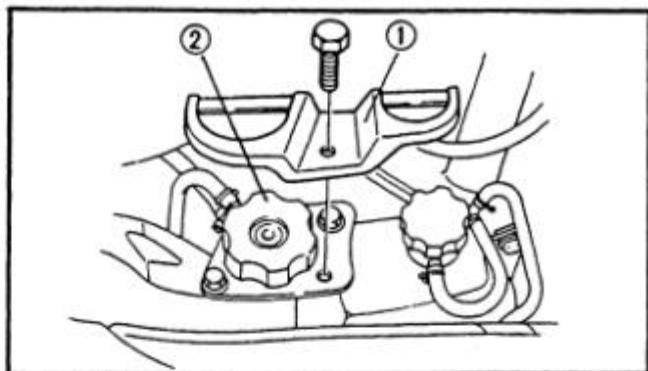

COOLANT REPLACEMENT

WARNING:

Do not remove the radiator cap when the engine and radiator are hot.

1. Remove:
 - Cap retainer ①
 - Radiator cap ②
 - Lower cowling
2. Place an open container under the engine.
3. Remove:
 - Drain bolts ①
 Drain the coolant.

WATER PUMP

DISASSEMBLY

NOTE:

- Be sure to drain the coolant before disassembly of the cooling system components.
- Refer to Engine Disassembly for water pump disassembly.

① Water pump

1. Remove:
 - Water pump cover ①
 - Gasket ②
 - O-ring ③
 - Circlip ④
 - Washer ⑤
 - Driven gear ⑥
 - Dowel pins ⑦
 - Impeller shaft ⑧
2. Eliminate deposits from the impeller and water pump housing.

⑨ Water pump housing

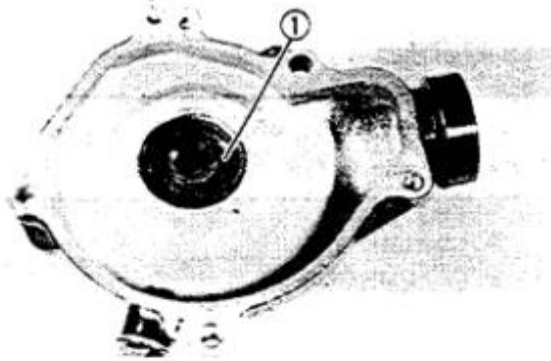

INSPECTION

1. Inspect:
 - Oil seal ①
Wear/Damage → Replace.
 - Impeller
Cracks/Wear/Damage → Replace.
 - O-rings (Housing and water jacket)
Wear/Damage → Replace.

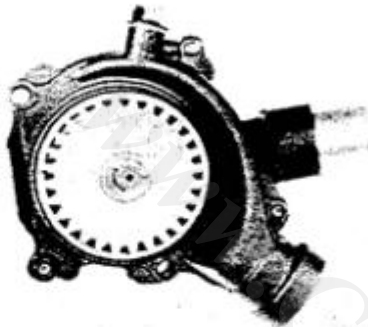

ASSEMBLY

1. Assembly:
 - Water pump
Reverse the disassembly procedures.

	<p>Water Pump Cover: 10 Nm (1.0 m·kg, 7.2 ft·lb)</p>
---	---

INSTALLATION

1. Install:
 - Water jacket (With new O-ring)
(into the water pump)
2. Install:
 - Water pump (With new O-ring)
3. Tighten:
 - Bolts

	<p>Water Pump: 10 Nm (1.0 m·kg, 7.2 ft·lb)</p> <p>Drain Bolt: 16 Nm (1.6 m·kg, 11 ft·lb)</p>
---	--

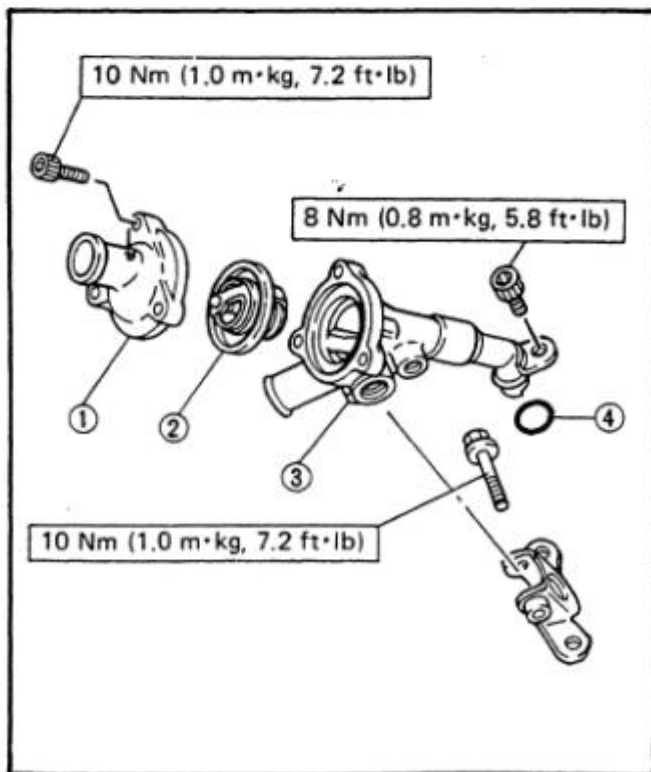

4. Connect:
 - Outlet hose
 - Bypass hose
5. Tighten:
 - Clamp screw

THERMOSTATIC VALVE

- ① Thermostat cover
- ② Thermostatic valve
- ③ Thermostat housing
- ④ O-ring

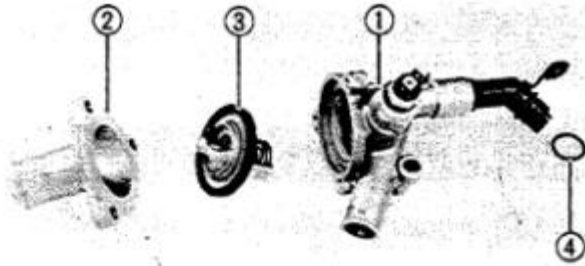

REMOVAL

1. Drain:
 - Coolant
 2. Remove:
 - Thermostat housing ①
 - Thermostat cover ②
 - Thermostatic valve ③
 - O-ring ④
- Refer to CHAPTER 3 "ENGINE REMOVAL".

INSPECTION AND ASSEMBLY

1. Check:
 - Thermostatic valve

Out of specification → Replace.

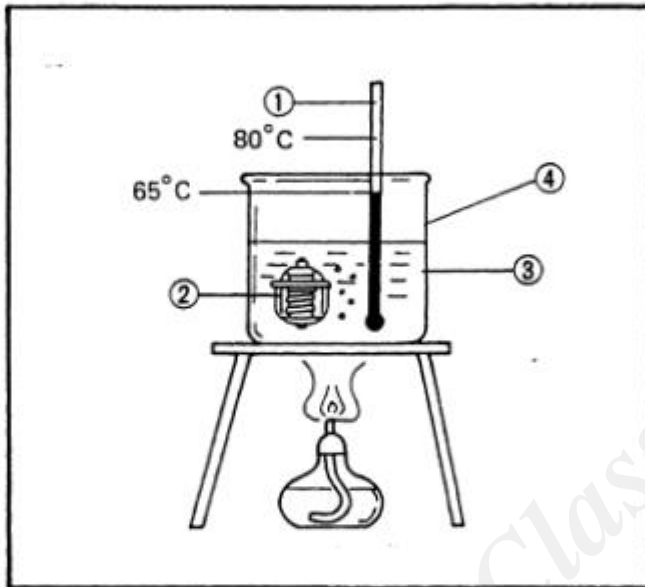

Inspection steps:

- Suspend thermostatic valve in a vessel of water.
 - Place reliable thermometer in water.
 - Heat water slowly.
 - Observe thermometer.
- While stirring water continually.



Thermostatic Valve:

Opening Temperature:

65°C (149°F)

Full Open Temperature/Lift:

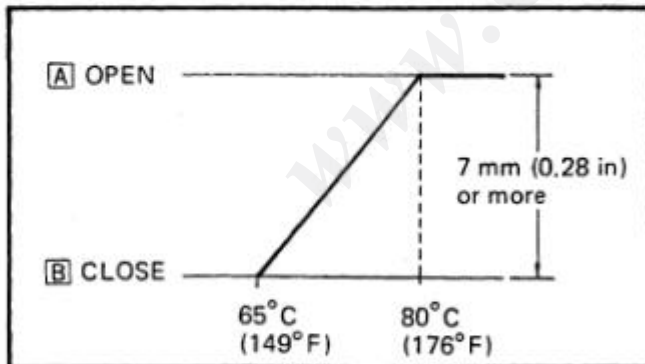
80°C (176°F)/7 mm (0.28 in)
or more

NOTE:

Thermostat is sealed and its setting is specialized work. If its accuracy is in doubt, always replace it. A faulty unit could cause serious overheating or overcooling.

1. Thermometer
2. Thermostatic valve
3. Water
4. Vessel

2. Inspect:
 - O-ring ①

Wear/Damage → Replace.



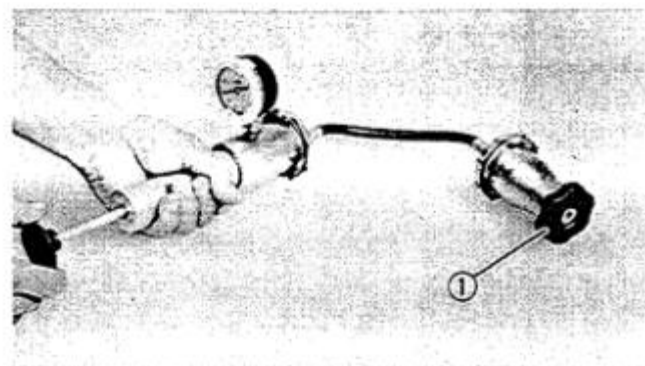
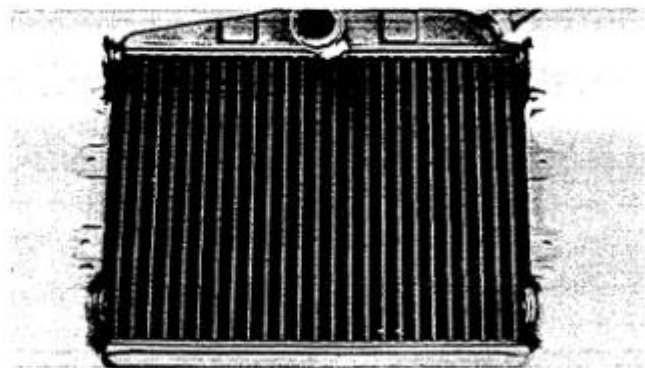
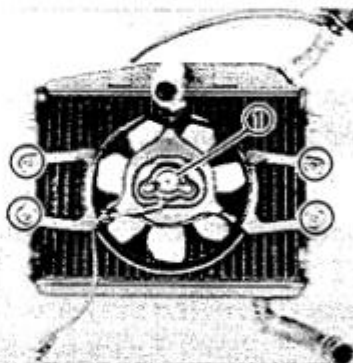
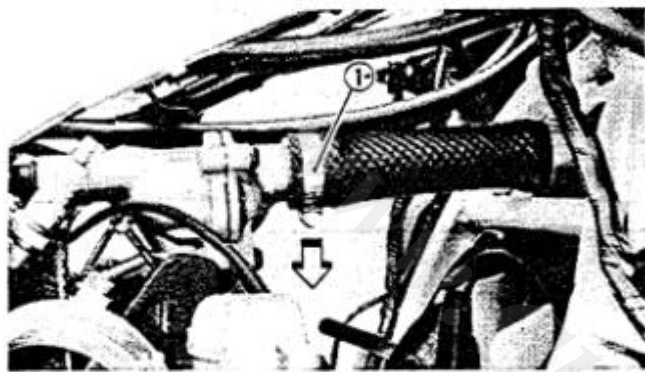

3. Install:
 - Thermostatic valve ①

NOTE:

Line up the valve breather hole ② with the housing projection.

- Thermostat cover
- Thermostat housing

4. Connect:
 - Hoses
 5. Install:
 - Air filter box
 - Air ducts
 - Center cowlings
 - Lower cowling
 6. Add:
 - Coolant
- ① Clamp

RADIATOR**DISASSEMBLY**

1. Drain:
 - Coolant
2. Remove:
 - Radiator assembly
Refer to CHAPTER 3 "ENGINE REMOVAL".
 - Fan motor assembly ①

INSPECTION

1. Inspect:
 - Radiator fins
Obstruction → Blow out with compressed air through rear of radiator.
Flattened → Repair.
 - Coolant hoses
Cracks/Damage → Replace.
2. Measure:
 - Valve opening pressure (Radiator cap ①)
Use the Cooling System Tester (90890-01325).
Out of specification → Replace.

Valve Opening Pressure:

78 ~ 98 kPa (0.8 ~ 1.0 kg/cm²,
11.4 ~ 14.2 lb/in²)

3. Check:
 - Valve (Radiator cap)
 - Weak spring/Defective seating → Replace radiator cap.

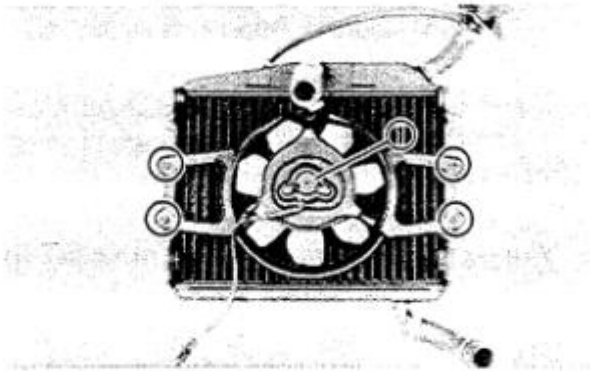

ASSEMBLY

1. Install:
 - Fan motor assembly ①
2. Tighten:
 - Bolts

	<p>Fan Motor: 7 Nm (0.7 m·kg, 5.1 ft·lb)</p>
---	---

3. Install:
 - Radiator assembly
4. Tighten:
 - Bolts

	<p>Radiator: 7 Nm (0.7 m·kg, 5.1 ft·lb)</p>
---	--

5. Install:
 - Air filter box
 - Air ducts
 - Center cowlings
 - Lower cowling
 - Refer to disassembly procedure.
6. Add:
 - Coolant
7. Check:
 - Cooling system

<p>Inspection steps:</p> <ul style="list-style-type: none"> • Connect the Cooling System Tester (90890-01325). • Apply 1.0 kg/cm² (14 lb/in²) pressure. • Measure pressure with gauge.
--

Decrease of pressure (leaks) → Repair as required.

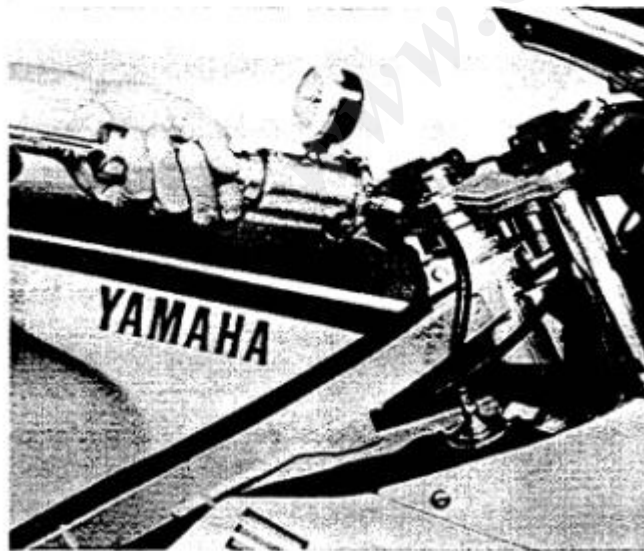

**Coolant:**

High-Quality Ethylene Glycol
Anti-Freeze Containing Anti-
Corrosion Inhibitors for Aluminum
Engines.

Collant and Soft Water Mix Ratio:
50%/50%

Total Amount:

1.95 L (1.72 Imp qt, 2.06 US qt)

Reservoir Tank Capacity:

0.35 L (0.31 Imp qt, 0.37 US qt)

From LOW to FULL Level:

0.25 L (0.2 Imp qt, 0.3 US qt)

CAUTION:

Hard water or salt water is harmful to the engine parts. You may use boiled water or distilled water if no soft water is available.

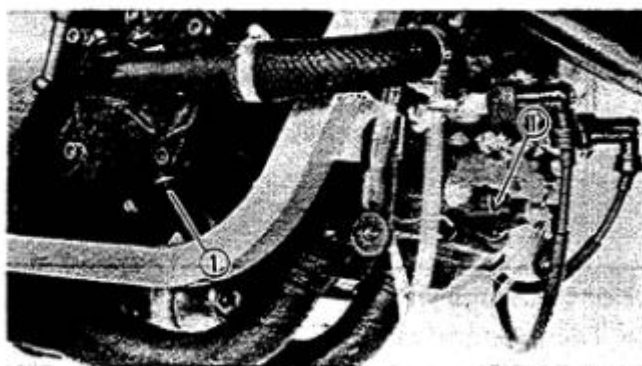
**COOLANT FILLING**

1. Tighten:
 - Coolant drain bolts ①

**Drain Bolt:**

16 Nm (1.6 m·kg, 11 ft·lb)

2. Fill:
 - Radiator

Coolant filling steps:

- Remove the radiator cap.
- Pour coolant into the radiator to specified level.
- Start the engine (Coolant level decreases).
- Add coolant while the engine is running.
- Stop the engine when coolant level stabilizes.



- Add coolant again to specified level.
- Install the radiator cap.

CAUTION:

Always check coolant level, and check for coolant leakage before starting the engine.

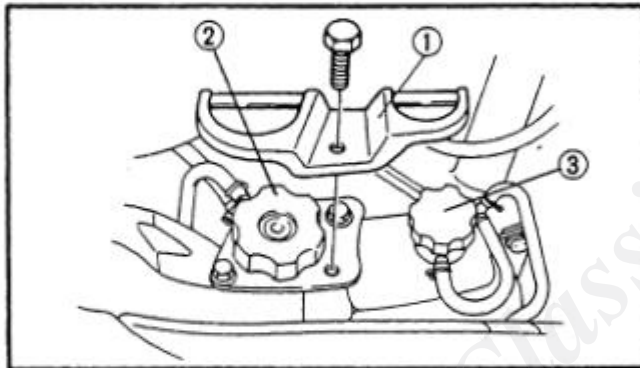
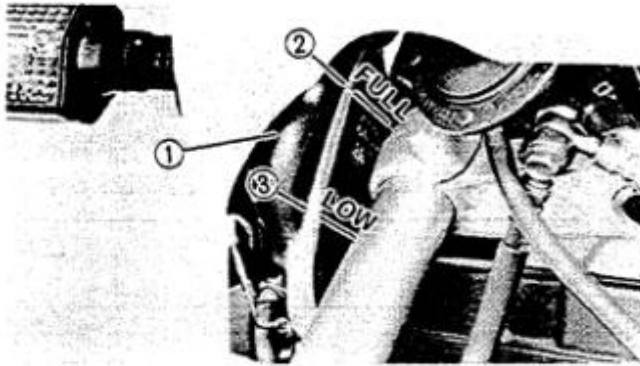

3. Fill:
 - Reservoir tank ①
Add coolant until liquid reaches "FULL" level mark.

② "FULL" level

③ "LOW" level

4. Install:
 - Radiator cap ②
 - Reservoir tank cap ③
 - Cap retainer ①

CHAPTER 5. CARBURETION

CARBURETOR	5-1
SECTION VIEW	5-3
CARBURETOR OVERHAUL.....	5-5
REMOVAL.....	5-5
DISASSEMBLY	5-5
INSPECTION	5-7
ASSEMBLY	5-11
FLOAT HEIGHT ADJUSTMENT.....	5-11
INSTALLATION	5-11
FUEL LEVEL ADJUSTMENT	5-13

www.ClassicCycles.org



CARBURETION

CARBURETOR

- 1. Top cover
- 2. Jet needle
- 3. Throttle valve
- 4. Needle jet
- 5. Bracket
- 6. Pilot jet
- 7. Main jet
- 8. Pilot air jet
- 9. Valve seat
- 10. Float
- 11. Float chamber
- 12. Drain screw
- 13. Carburetor holder
- 14. Starter plunger
- 15. Synchronizing screw
- 16. Throttle stop screw
- 17. Choke lever
- 18. To right upper carburetor
- 19. To right lower carburetor
- 20. To left lower carburetor
- 21. To left upper carburetor

SPECIFICATIONS	
Main jet	# 195
Main air jet	# 1.8 (upper cylinder) # 1.6 (lower cylinder)
Jet needle	5LT14-3
Needle jet	O-0
Pilot jet	# 22.5
Pilot air jet	# 1.1
Fuel level	1.5 ± 1.0 mm (0.06 ± 0.04 in)
Float height	21.0 ± 1.0 mm (0.83 ± 0.04 in)
Float valve seat	φ 2.8
Engine idle speed	1,250 r/min

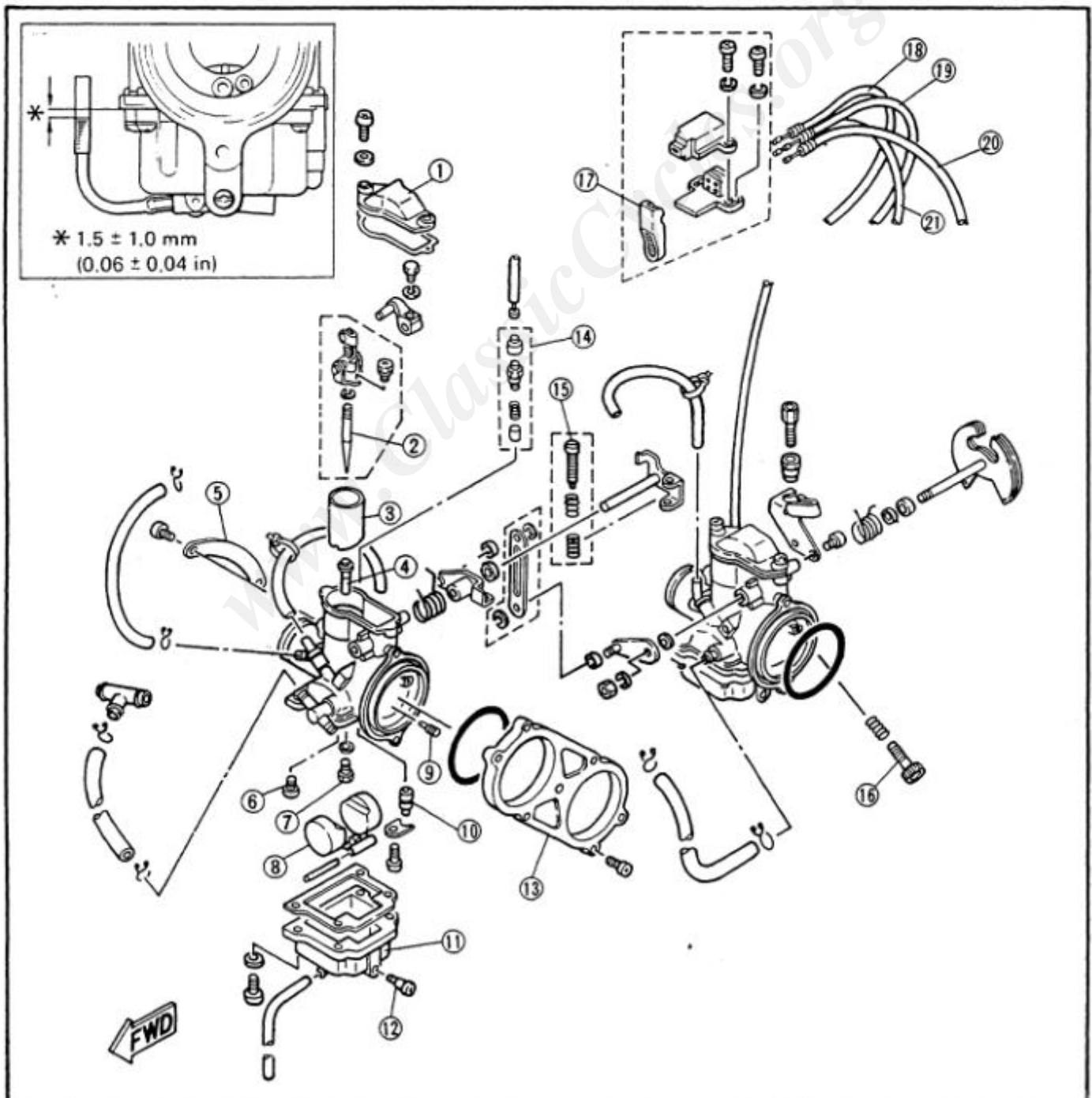



SECTION VIEW

- | | |
|----------------------|--------------------|
| 1. Top cover | 9. Main jet |
| 2. Gasket | 10. Needle jet |
| 3. Lever | 11. Float |
| 4. Pilot air jet | 12. Pilot jet |
| 5. Carburetor holder | 13. Jet needle |
| 6. O-ring | 14. Throttle valve |
| 7. Valve seat | 15. Spring |
| 8. Drain screw | |

A	←	AIR
B	←	MIXTURE
C	←	FUEL

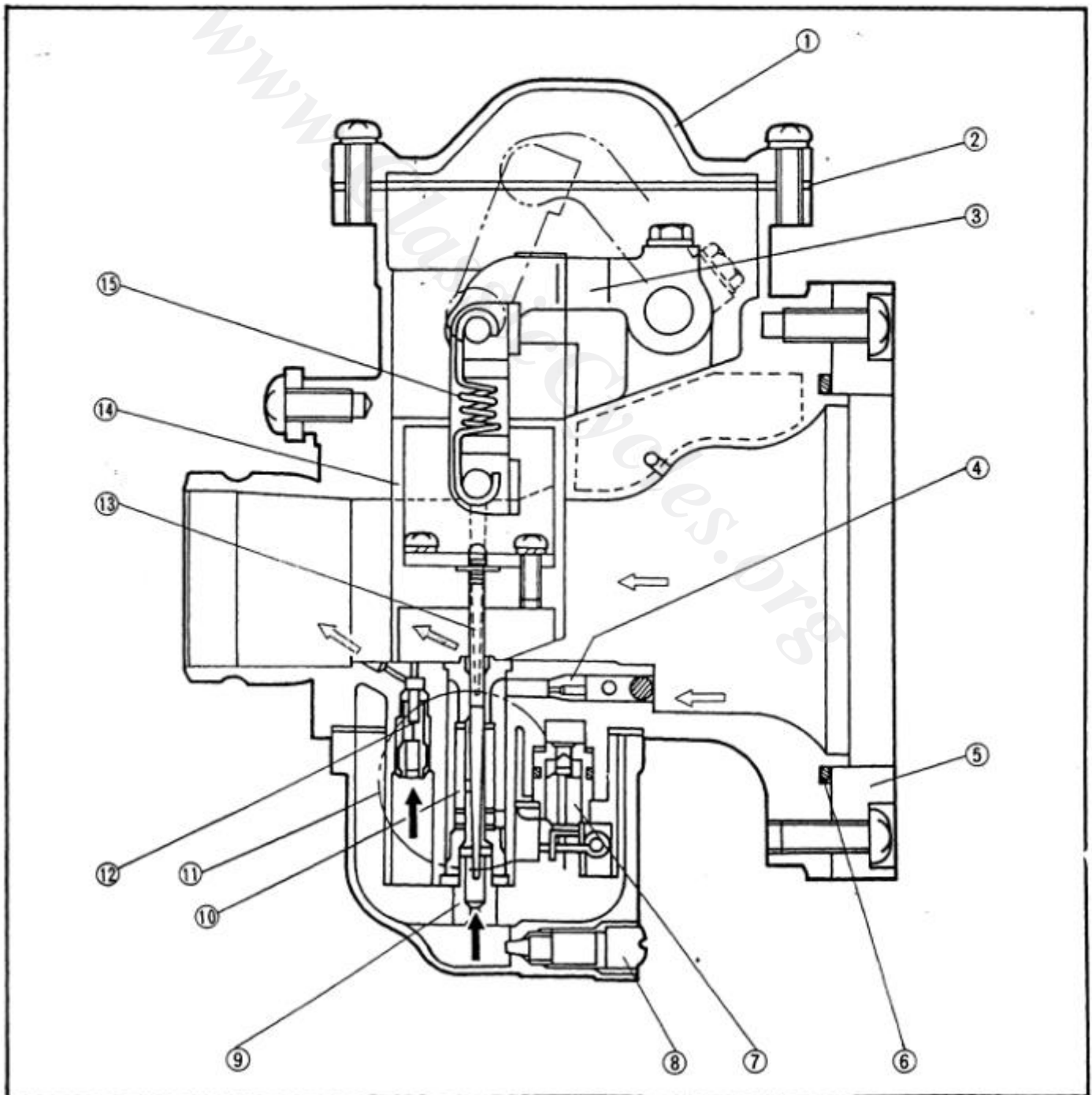

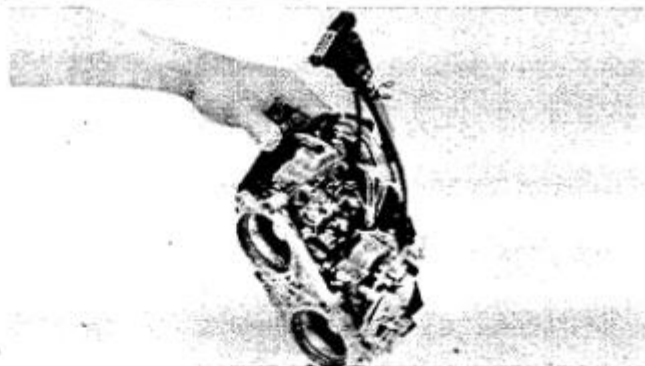

CARBURETOR OVERHAUL

REMOVAL

1. Remove:
 - Carburetor assembly
 - Refer to engine removal section.

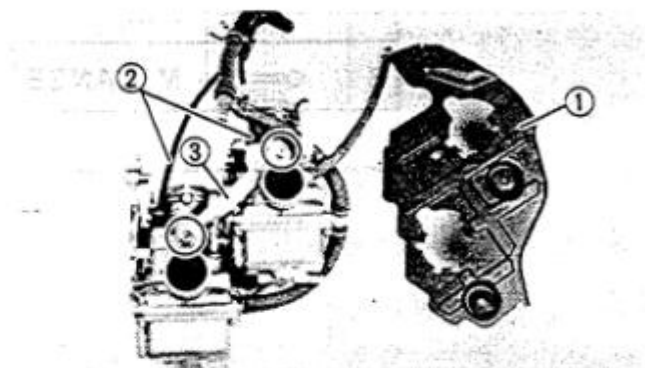

DISASSEMBLY

1. Disconnect:
 - Carburetor cover (1)
 - Hoses
2. Remove:
 - Starter plungers (2)
 - Bracket (3)
3. Remove:
 - Circlip (1)
 - Washer (2)
 - Carburetor holder (3)
 - Carburetors
 - O-rings

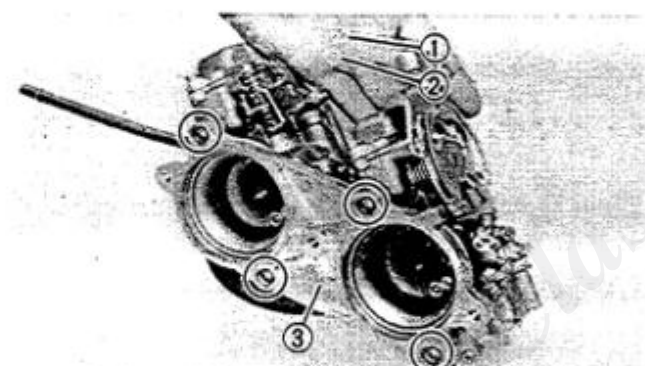

4. Remove:
 - Top cover (1)
 - Gasket (2)
 - Throttle pulley (3)
 - Spring (4)

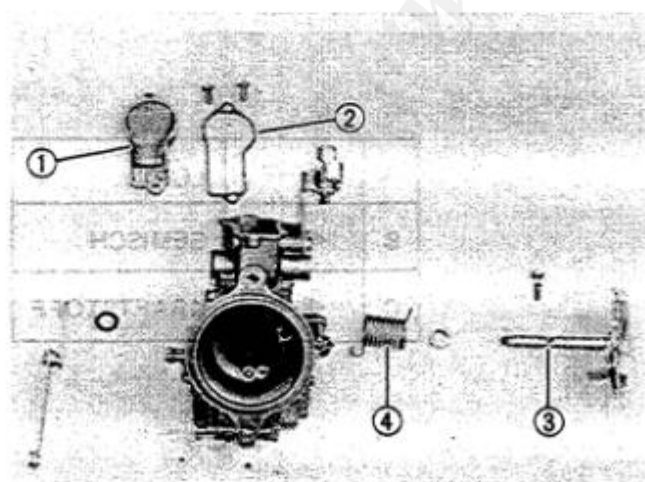

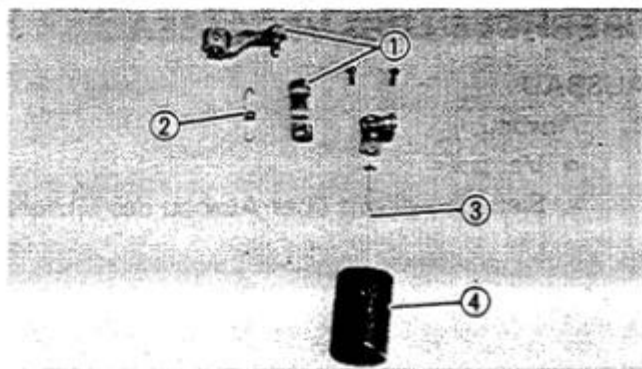

5. Remove:
- Lever ①
 - Spring ②
 - Jet needle ③
 - Throttle valve ④
 - Float chamber
 - Gasket

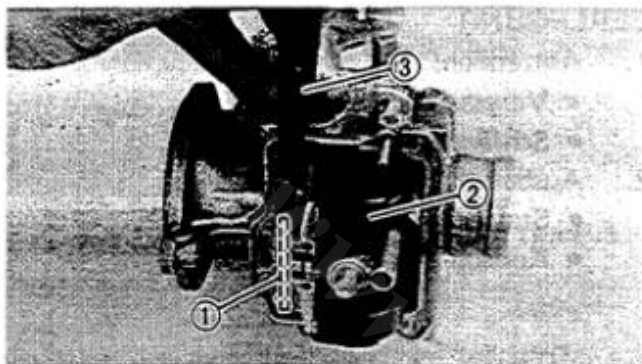

6. Remove:
- Float pin ①
 - Float ②

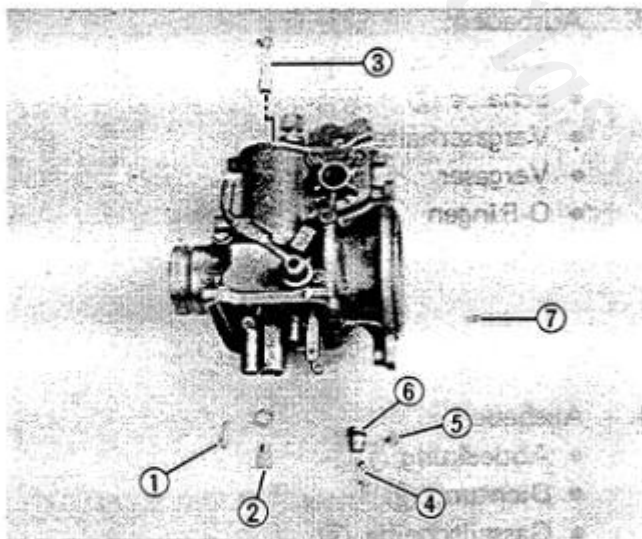

- ③ Center punch
7. Remove:
- Pilot jet ①
 - Main jet ②
 - Needle jet ③
 - Needle valve ④
 - Screw ⑤
 - Valve seat ⑥
 - Pilot air jet ⑦

NOTE: _____
 Remove the needle jet toward the throttle valve.

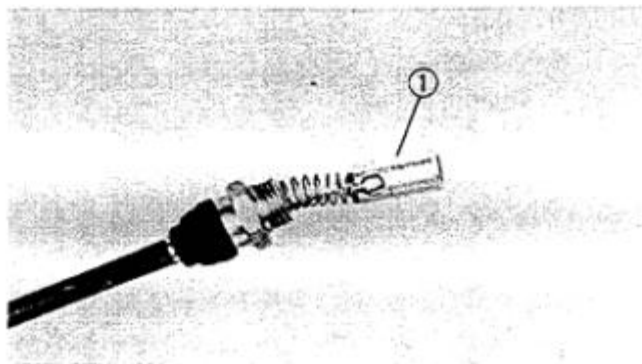

INSPECTION

1. Inspect:
- Starter plunger ①
 Damage/Wear → Replace.
 - Throttle valve
 Scratches/Wear → Replace.
 - Jet needle
 Bends/Wear → Replace.

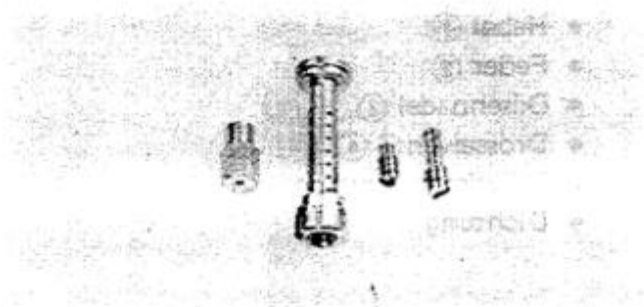

2. Inspect:
 - Jets
Contamination → Clean.

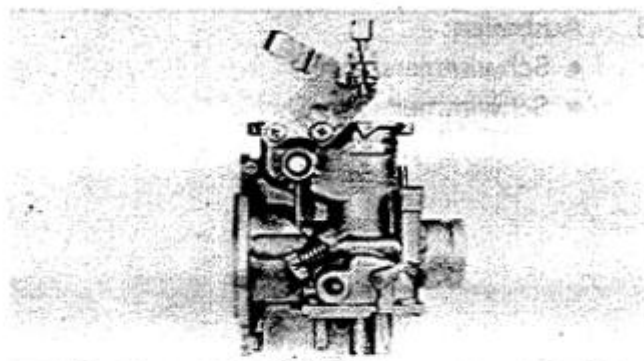

3. Inspect:
 - Carburetor body
 - Fuel passage
Contamination → Clean.

NOTE: _____

- Wash the carburetor in a petroleum-based solvent. Do not use any caustic carburetor cleaning solutions.
- Blow out all passages and jets with compressed air.

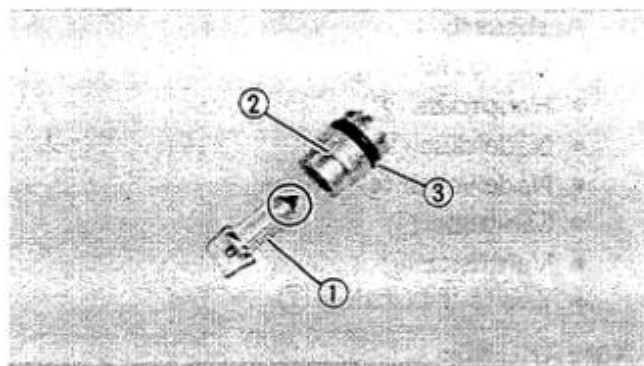

4. Inspect:
 - Needle valve ①
 - Valve seat ②
Wear → Replace as a set.

③ O-ring



5. Inspect:
 - Float
Damage/Torn → Replace.

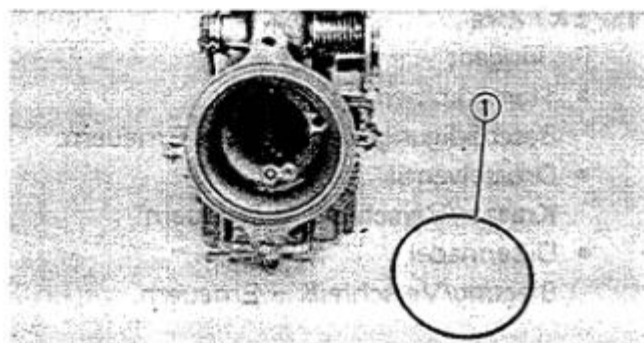

6. Inspect:
 - O-rings ①
Wear/Damage → Replace.
 - Oil seals
Wear/Damage → Replace.



ASSEMBLY

1. Assembly:

- Carburetors
Reverse the disassembly procedures.

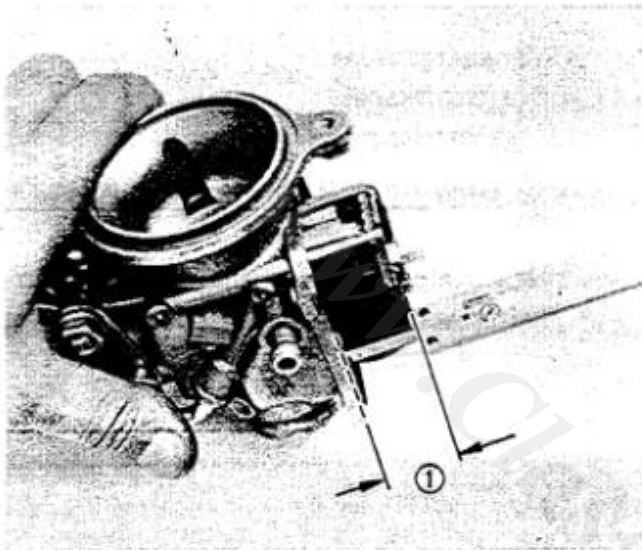

FLOAT HEIGHT ADJUSTMENT

1. Measure:

- Float height ①
Out of specification → Adjust.

Float height measurement steps:

- Hold the carburetor in an upside down position.
- Incline the carburetor at 60 ~ 70° (so that the end of the float valve does not hang down as a result of float weight).
- Measure the distance from the mating surface of the float chamber (gasket removed) to the top of the float.

NOTE:

The float should be just resting on, but not depressing, the spring loaded inlet needle.



Float Height ①:

$21.0 \pm 1.0 \text{ mm}$ ($0.83 \pm 0.04 \text{ in}$)



Float height adjustment step:

- Remove the float.
- Adjust float height by bending the float tang ① slightly.
- Repeat the procedure for other carburetors.

INSTALLATION

1. Install:

- Carburetors
Reverse the removal steps.

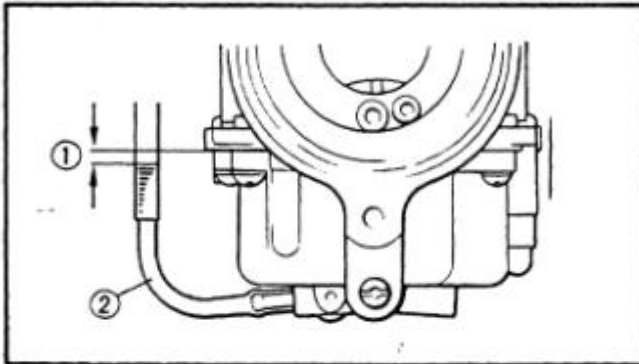
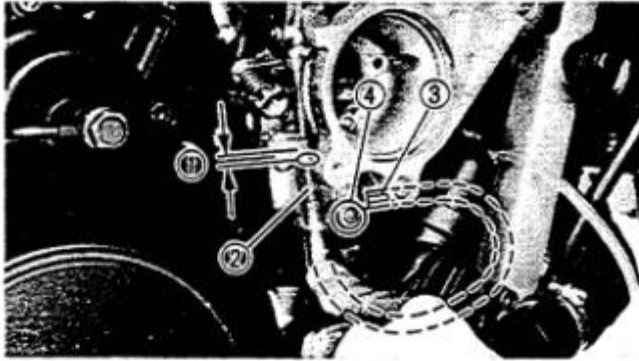

FUEL LEVEL ADJUSTMENT

1. Measure:

- Fuel level ①
- Out of specification → Adjust.

Measurement steps:

- Place the motorcycle on a level surface.
- Use a garage jack under the engine to ensure that the carburetor is positioned vertically.
- Insert one end of a pipe, 3.5 mm (0.14 in) in inside diameter, 6 mm (0.24 in) in outside diameter, and 50 mm (2.00 in) in length about 10 mm (0.39 in) into the Fuel Level Gauge (90890-01312) ②, and insert the other end into the drain nozzle ③.
- Loosen the drain screw ④ and start the engine.
- Check the fuel level, one carburetor at a time.



Fuel Level ① :

Below the carburetor body
 $1.5 \pm 1.0 \text{ mm (} 0.06 \pm 0.04 \text{ in)}$



2. Adjust:

- Fuel level
- If necessary.

Adjustment steps:

- Remove the carburetors.
- Adjust float level by bending the float tang ① slightly.
- Repeat the procedure for the other carburetors.

3. Adjust:

- Carburetor cables
 - Carburetor synchronization
 - Engine idle speed
- Refer to CHAPTER 2 for adjustment.



Engine Idle Speed:

1,250 r/min

CHAPTER 6. CHASSIS

FRONT WHEEL	6-1
REMOVAL	6-3
TUBELESS TIRES AND CAST WHEELS.	6-3
INSPECTION	6-5
INSTALLATION	6-9
REAR WHEEL	6-13
REMOVAL	6-15
INSPECTION	6-17
INSTALLATION	6-17
DRIVE CHAIN LUBRICATION.	6-19
DRIVE AND DRIVEN CHAIN SPROCKET.	6-21
FRONT AND REAR BRAKE	6-21
AIR BLEEDING	6-21
CALIPER PAD REPLACEMENT (FRONT)	6-25
CALIPER PAD REPLACEMENT (REAR)	6-31
CALIPER DISASSEMBLY (FRONT AND REAR)	6-35
BRAKE MASTER CYLINDER (FRONT)	6-41
BRAKE MASTER CYLINDER (REAR)	6-47
FRONT FORK	6-53
REMOVAL	6-55
DISASSEMBLY	6-57
INSPECTION	6-59
REASSEMBLY	6-61
INSTALLATION	6-65
ANTI-DIVE SYSTEM	6-69
STEERING HEAD	6-75
REMOVAL	6-77
INSPECTION	6-77
INSTALLATION	6-79
REAR SHOCK ABSORBER	6-83
REMOVAL	6-87
INSPECTION	6-87
INSTALLATION	6-89

SWINGARM AND RELAY ARM 6-91
 SWINGARM AND RELAY ARMS INSTALLATION 6-93
 SWINGARM FREE PLAY INSPECTION 6-97
 REMOVAL 6-97
 INSPECTION 6-99
 INSTALLATION 6-101

CABLES AND FITTINGS 6-105
 CABLE MAINTENANCE 6-105

www.ClassicCycles.org

CHASSIS

FRONT WHEEL

- 1. Collar
- 2. Oil seal
- 3. Bearing
- 4. Spacer
- 5. Spacer flange
- 6. Meter clutch
- 7. Clutch retainer
- 8. Gear unit
- 9. Washer

Basic weight: With oil and full fuel tank	199 kg (439 lb) 205 kg (452 lb) (G)	
Maximum load *	211 kg (465 lb) 205 kg (452 lb) (G)	
Cold tire pressure	Front	Rear
Up to 90 kg (198 lb) load *	196 kPa (2.0 kg/cm ² , 28 psi)	226 kPa (2.3 kg/cm ² , 32 psi)
90 kg (198 lb) ~ Maximum load *	226 kPa (2.3 kg/cm ² , 32 psi)	284 kPa (2.9 kg/cm ² , 42 psi)
High speed riding	226 kPa (2.3 kg/cm ² , 32 psi)	245 kPa (2.5 kg/cm ² , 36 psi)

*Load is the total weight of cargo, rider, passenger, and accessories.

(G): For Germany

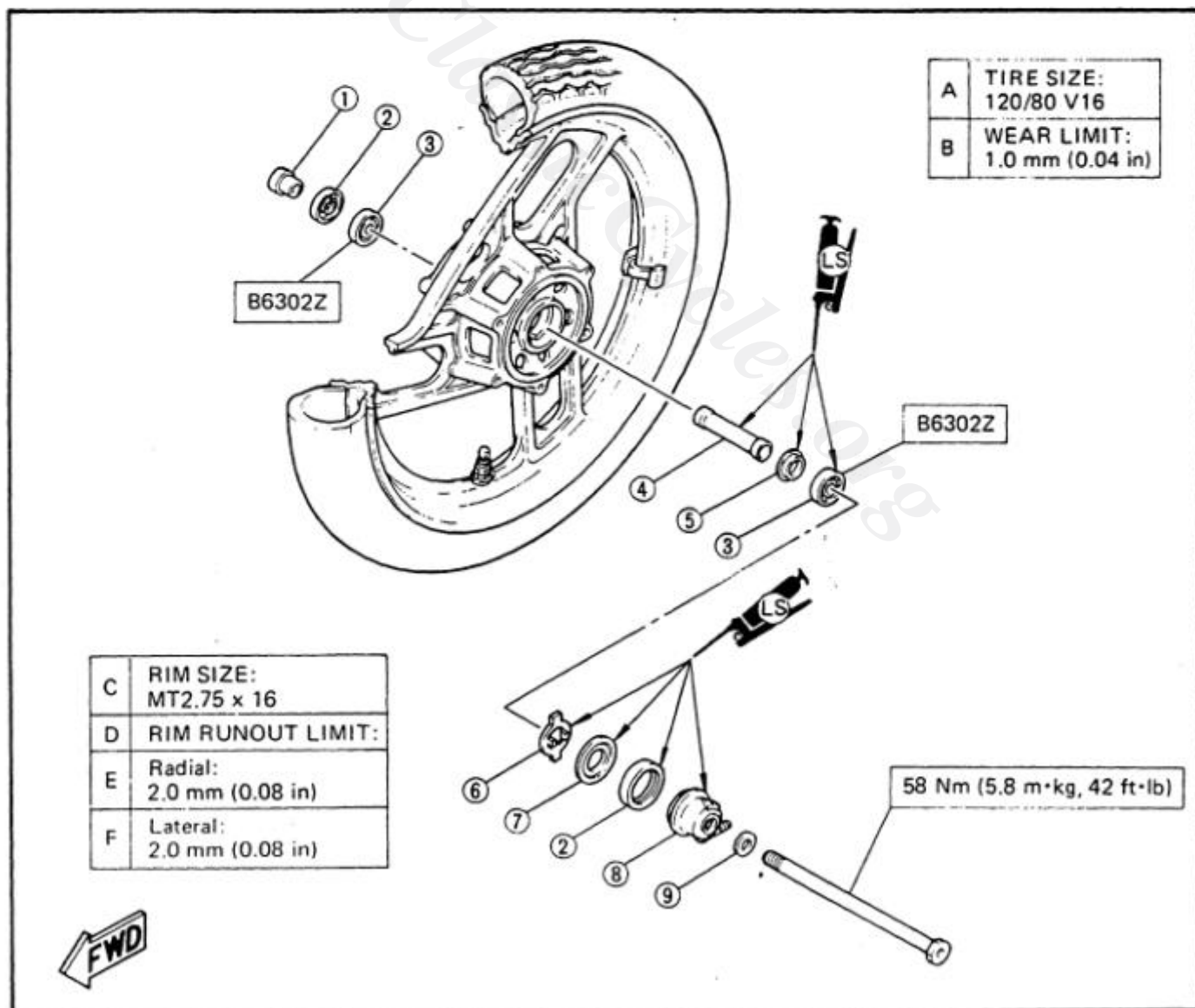

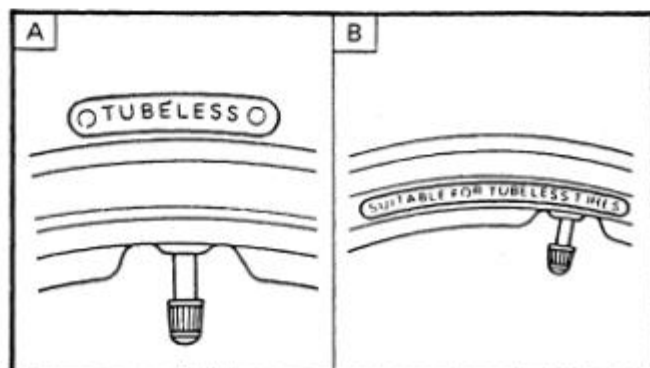
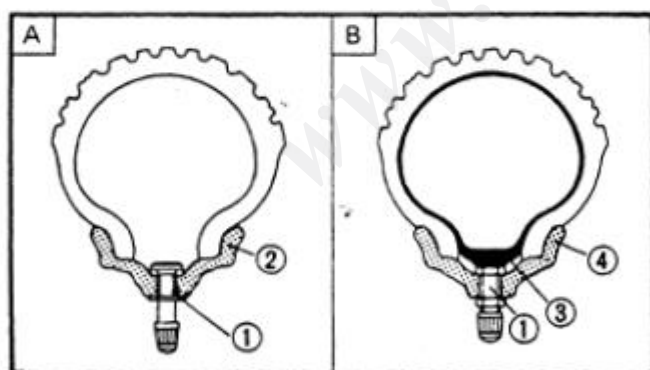
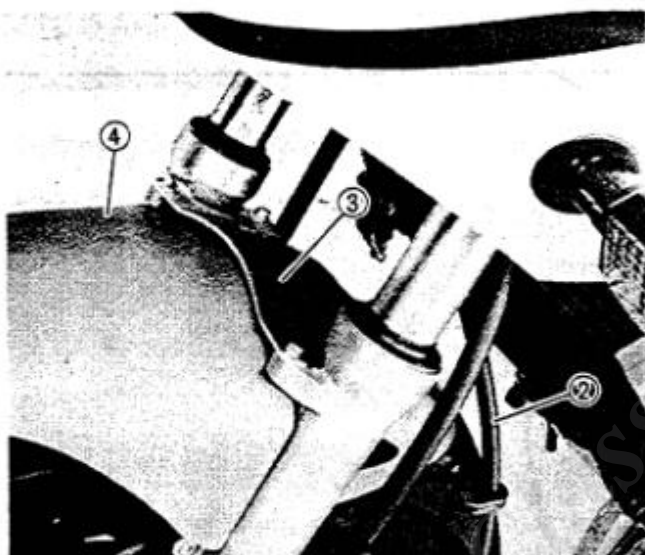
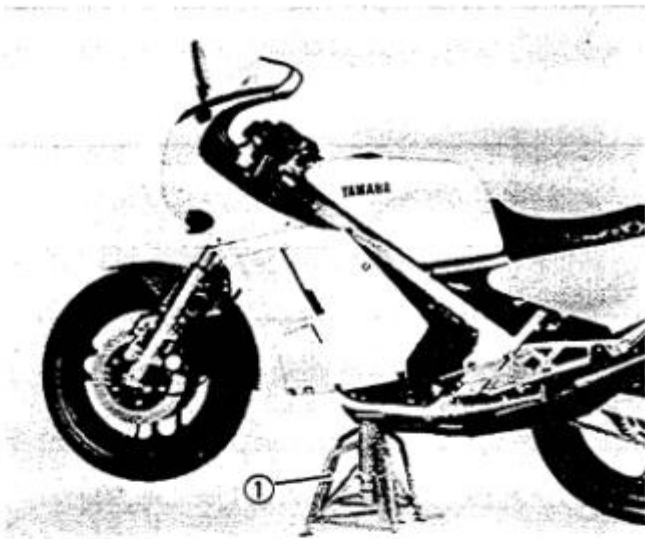

REMOVAL

1. Remove:
 - Lower cowling
2. Place the motorcycle on a block or other suitable stand ① under the frame.
3. Remove:
 - Speedometer cable ②
 - Fork brace ③
 - Front fender ④
 - Brake caliper (One side only)

NOTE:

Do not squeeze the brake lever while the wheel is off the motorcycle.

4. Loosen:
 - Axle pinch bolts
5. Remove:
 - Front axle
 - Front wheel

TUBELESS TIRES AND CAST WHEELS

This motorcycle is equipped with cast wheels designed for either tube or tubeless tires. Tubeless tires are installed as standard equipment.

- ① Air valve
- ② Cast wheel (Tubeless wheel)
- ③ Tube
- ④ Cast wheel
- A TUBELESS-TYPE TIRE
- B TUBE-TYPE TIRE

WARNING:

Do not attempt to use tubeless tires on wheels designed for tube-type tires only. Sudden tire deflation and loss of control may occur causing possible injury.

Be sure to install the proper tube when using tube-type tires.

- A TIRE
- B WHEEL

Tube-type Wheel	→ Tube-Type Tires only
Tubeless-type Wheel	→ Tube-type or Tubless tires



A	FRONT:	C	STANDARD TYPE	
D	Manufacture	E	Size	F Type
	Yokohama		120/80 V16	F101
	Michelin		120/80 V16	A48

B	REAR:	C	STANDARD TIRE	
D	Manufacture	E	Size	F Type
	Yokohama		130/80 V18	R101
	Michelin		130/80 V18	M48

NOTE:
Germany and Austria: It is not allowed to use tube-type tires on motorcycle originally equipped with tubeless tires.

WARNING:

This motorcycle is fitted with "V" range tires (for super high speed running). The following points must be observed in order for you to make fully effective use of these tires.

- Never fail to use "V" range tires in tire replacement. "S" or "H" tires may be in danger of bursting at super high-speeds.
- New tires have a relatively poor adhesion on the road surface so do not allow them to be subjected to high speed load from maximum speed until after a break-in run of approx. 100 km (60 mi).
- Before any high-speed runs, remember to allow a sufficient warm-up time for the tires.
- Always use the correct tire inflation pressure according to the operating conditions.

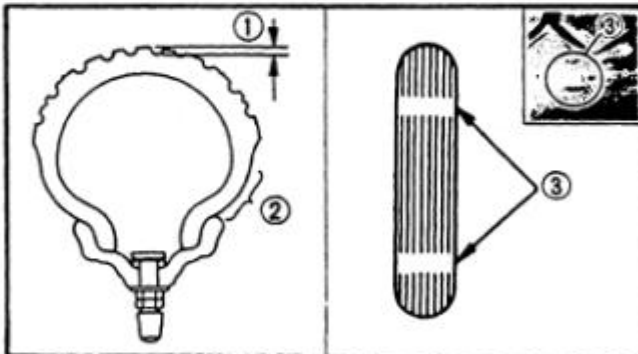

INSPECTION

1. Inspect:
 - Tire
Tire tread shows crosswise lines (minimum tread depth)/Cracks → Replace.

Minimum Tire Tread Depth:
1.0 mm (0.04 in)

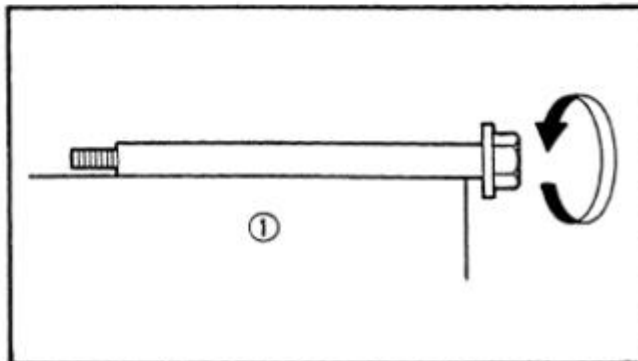

- ① Tread depth
 - ② Sidewall
 - ③ Wear indicator
2. Inspect:
 - Front axle
Roll the axle on a flat surface ①
Bends → Replace.

WARNING:

Do not attempt to straighten a bent axle.

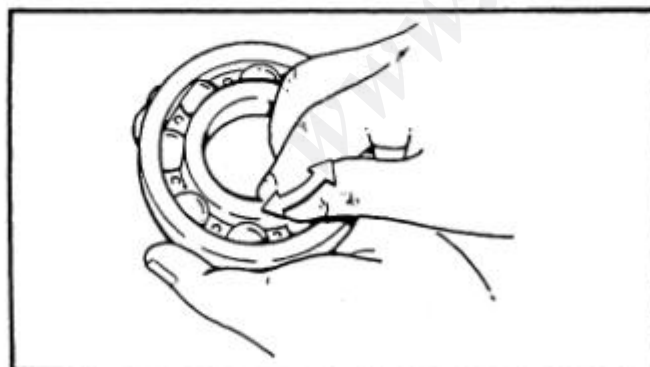
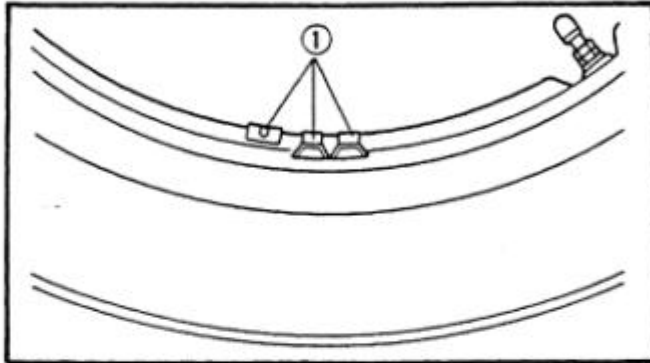
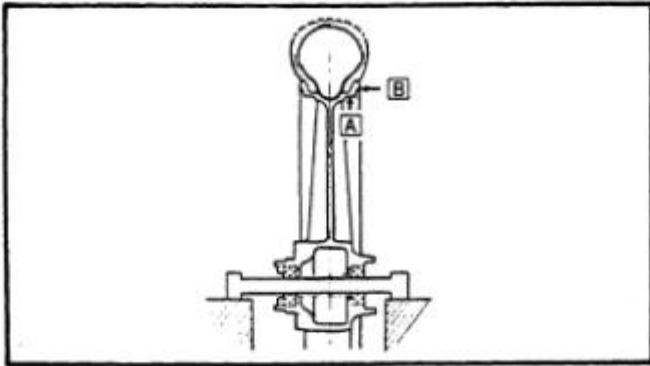

3. Inspect:
 - Wheel
Cracks/Bends/Warpage → Replace.
4. Measure:
 - Wheel runout
Out of specification → Replace.

**Rim Runout Limits:**Radial **A**: 2.0 mm (0.08 in)Lateral **B**: 2.0 mm (0.08 in)

5. Check:
 - Wheel balance
Out of balance → Adjust.

NOTE: _____
Balance wheels with the brake discs installed.

① Blancer weight

WARNING: _____

Ride conservatively after installing a tire to allow the tire to seat itself correctly on the rim.

CAUTION: _____

Be sure the valve stem locknut is tightened securely after repairing or replacing a tire and/or wheel.

6. Inspect:
 - Wheel bearings
Bearings allow play in the wheel hub or wheel turns roughly → Replace.

Wheel bearing replacement steps:

- Clean the outside of the wheel hub.
- Drive out the bearing.

WARNING: _____

Eye protection is recommended when using striking tools.

- Install the new bearing by reversing the previous steps.

CAUTION: _____

Do not strike the center race or balls of the bearing. Contact should be made only with the outer race.

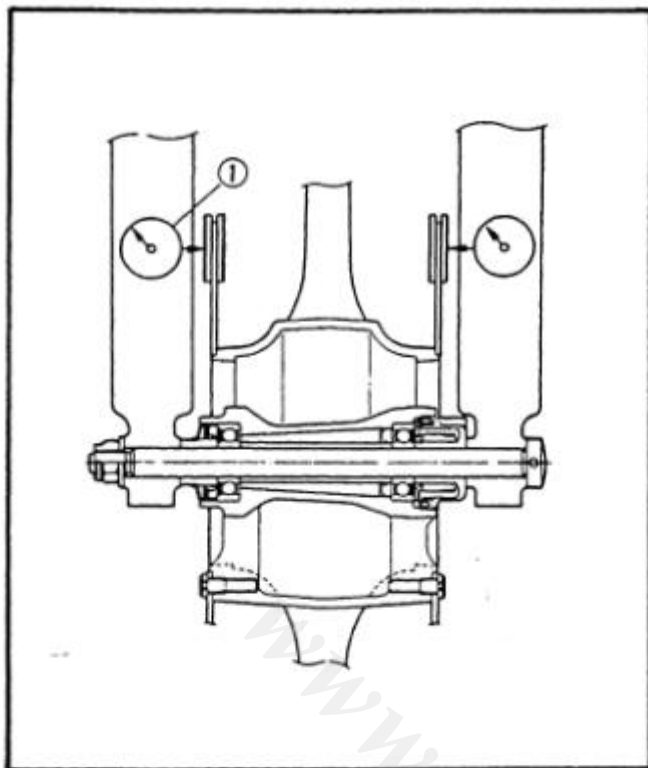

7. Inspect:
- Brake disc
Out of specification → Replace.



**Maximum Deflection
(Front and Rear):**
0.15 mm (0.006 in)
Minimum Disc Thickness:
Front: 7 mm (0.28 in)
Rear: 8 mm (0.31 in)

① Dial gauge

INSTALLATION

1. Install:
- Brake discs

NOTE: _____
The arrow mark ① on the disc must point toward the rotating direction of the wheel.

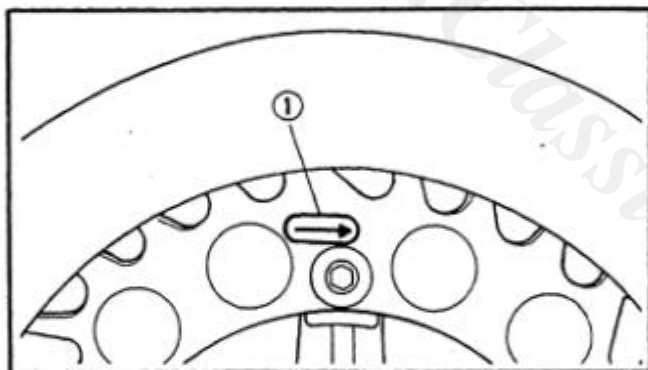

2. Tighten:
- Bolts



Brake Disc:
20 Nm (2.0 m·kg, 14 ft·lb)
LOCTITE®

Ⓐ DRIVE

3. Install:
- Front wheel
Reverse removal steps.

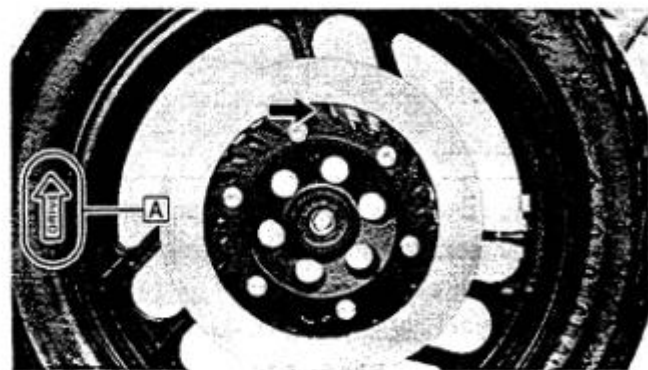

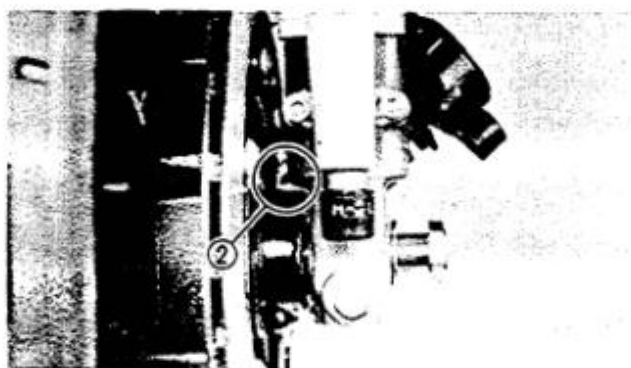
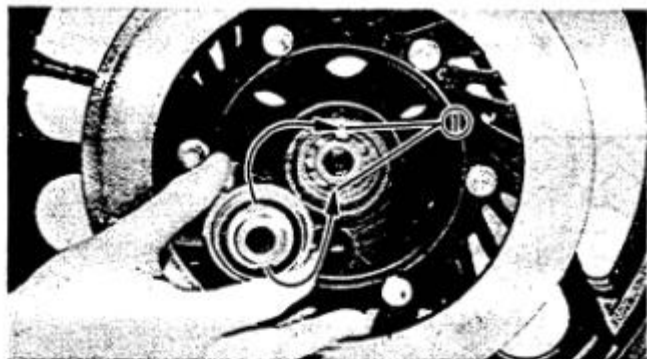

Note the following installation points:

- Lightly grease the front wheel oil seal lips and the gear teeth of the speedometer drive and driven gears.
(Use lightweight lithium base grease.)
- Be sure that the two projections ① inside the wheel hub mesh with the two slots in the speedometer clutch assembly.
- Be sure that the projecting portion ② (torque stopper) of the speedometer housing is positioned correctly.
- Compress the front forks several times to confirm proper fork operation before tightening the pinch bolt.

4. Tighten:
- Axle nut



Front Axle:

58 Nm (5.8 m·kg, 42 ft·lb)

5. Tighten:
- Pinch bolts



Front Axle Pinch:

20 Nm (2.0 m·kg, 14 ft·lb)

6. Install:
- Fork brace
 - Front fender



Front Fender:

9 Nm (0.9 m·kg, 6.5 ft·lb)

7. Install:
- Brake calipers



Brake Caliper:

35 Nm (3.5 m·kg, 25 ft·lb)

REAR WHEEL

1. Rear axle
2. Drive chain puller
3. Collar
4. Oil seal
5. Bearing
6. Spacer flange
7. Spacer
8. O-ring
9. Damper
10. Clutch hub
11. Driven sprocket (38T)

TIRE SIZE: 130/80 V18
WEAR LIMIT: 1.0 mm (0.04 in)
RIM RUNOUT LIMIT:
Radial: 2.0 mm (0.08 in)
Lateral: 2.0 mm (0.08 in)

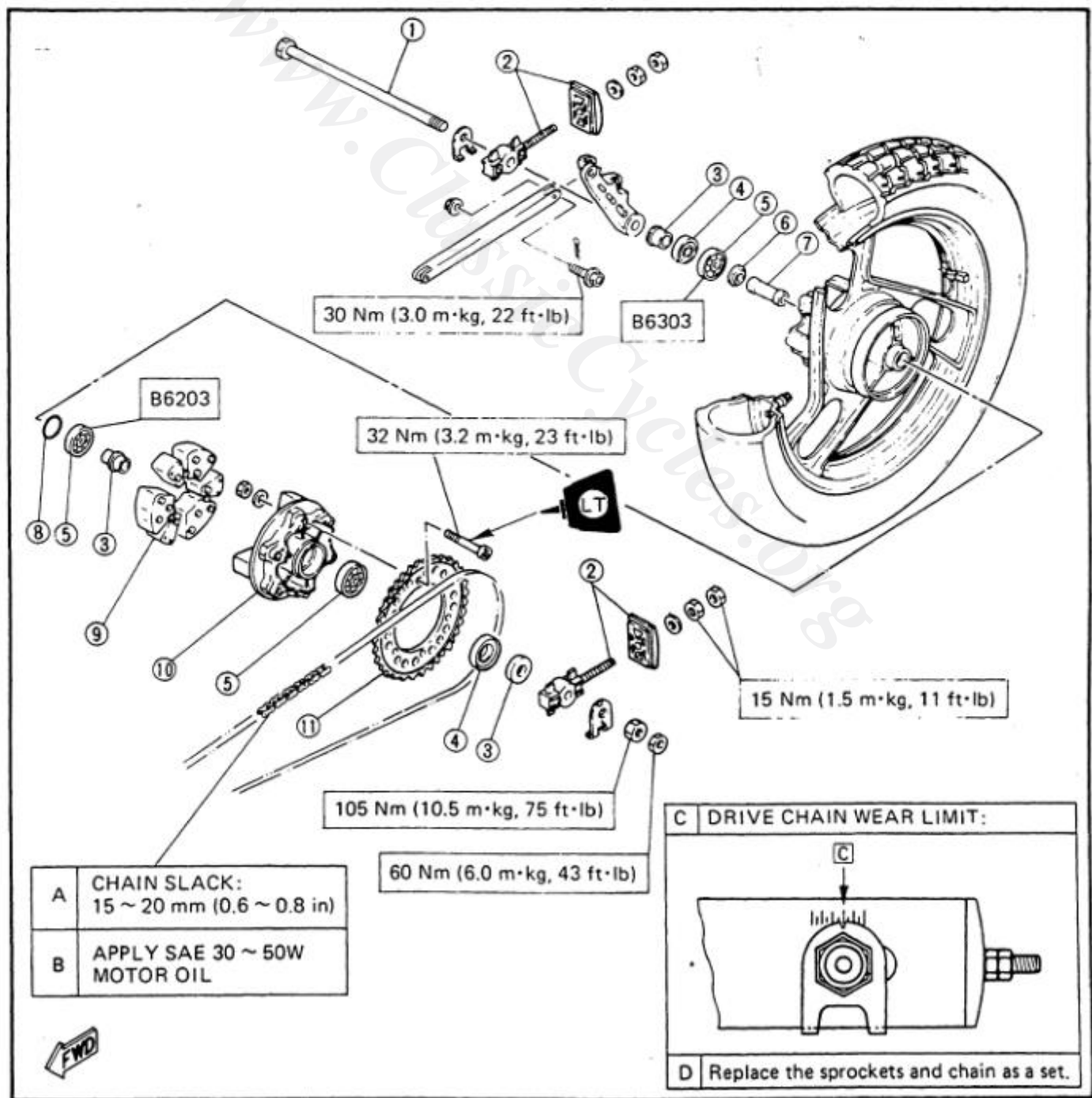

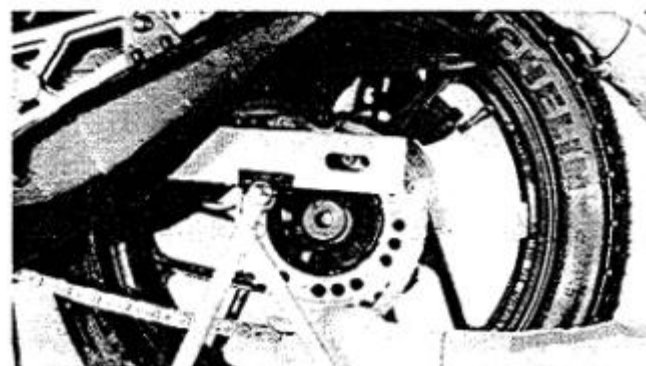
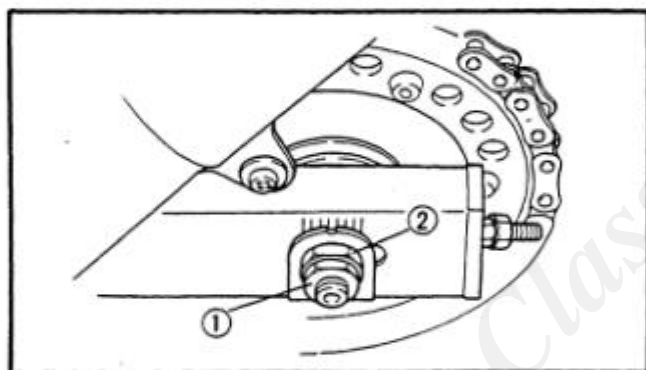
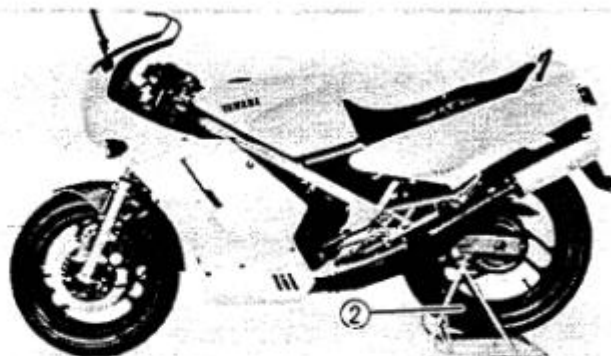
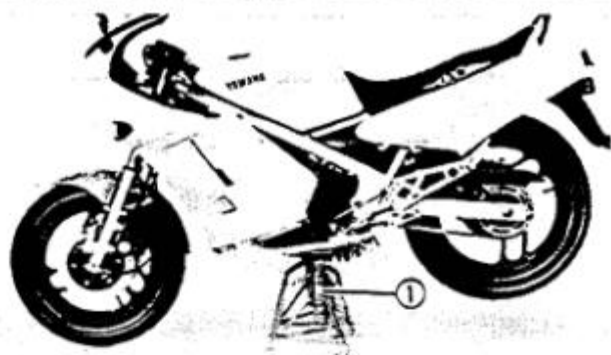

REMOVAL

1. Remove:
 - Lower cowling
 - Mufflers (Lower cylinders)
2. Place the motorcycle on a block or other suitable stand (1) under the frame.

or

Place the motorcycle on the Racing Stand (51X-W0780-00) (2).

3. Remove:
 - Lock nut (1)
 - Axle nut (2)

4. Remove:
 - Cotter pin (1)
 - Tension bar (2)
 - Rear axle shaft
5. Push the wheel forward and remove the drive chain.
6. Remove:
 - Rear wheel

NOTE:

Do not depress the brake pedal when the wheel is off the motorcycle as the brake pads will be forced shut.

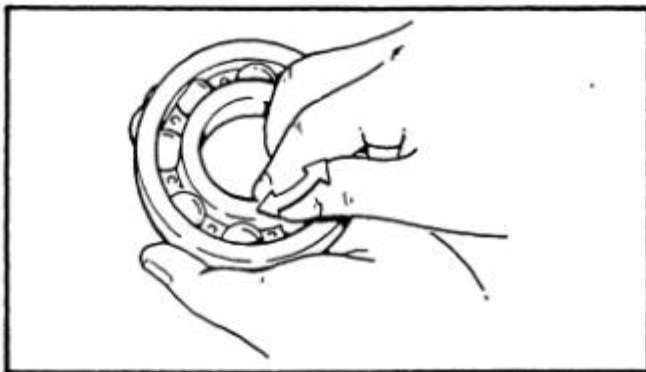

INSPECTION

Rear Axle Inspection

(See Front wheel, Axle Inspection Procedures)

Rear Wheel Bearing Replacement

(Similar to front wheel bearing replacement procedures)

Rear Wheel Inspection

(See Front Wheel, Inspection Procedures)

Disc Inspection

(See Front Wheel, Disc Inspection Procedure)

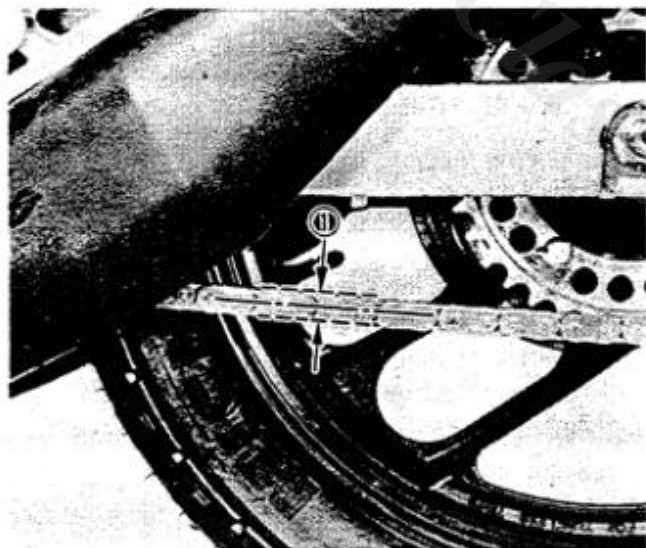

INSTALLATION

1. Install:

- Rear wheel
- Wheel axle

Reverse the removal procedure.

2. Adjust:

- Drive chain slack ①

Refer to CHAPTER 2 for Drive Chain Slack Adjustment.



Drive Chain Slack ①:

15 ~ 20 mm (0.6 ~ 0.8 in)

CAUTION:

Excessive chain slack will overload the engine and other vital parts; keep the slack within the specified limits.

NOTE:

Before checking and/or adjusting the chain slack, rotate the rear wheel through several revolutions. Check the chain slack several times to find the point where the chain is the tightest. Check and/or adjust the chain slack where the rear wheel is in this "tight chain" position.

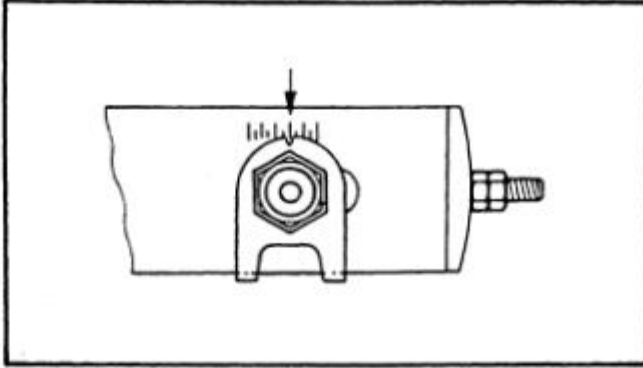
**NOTE:**

There are marks on each side of rear arm and on each chain puller; use them to check for proper alignment.

3. Check:
 - Alignment marks
Out of specification → Replace sprockets and chain as a set.
4. Tighten:
 - Axle nut
 - Locknut (Axle nut)
 - Locknut (Chain puller)
 - Tension bar

**Rear Axle:**

105 Nm (10.5 m·kg, 75 ft·lb)

Rear Axle (Locknut):

60 Nm (6.0 m·kg, 43 ft·lb)

Tension Bar:

30 Nm (3.0 m·kg, 22 ft·lb)

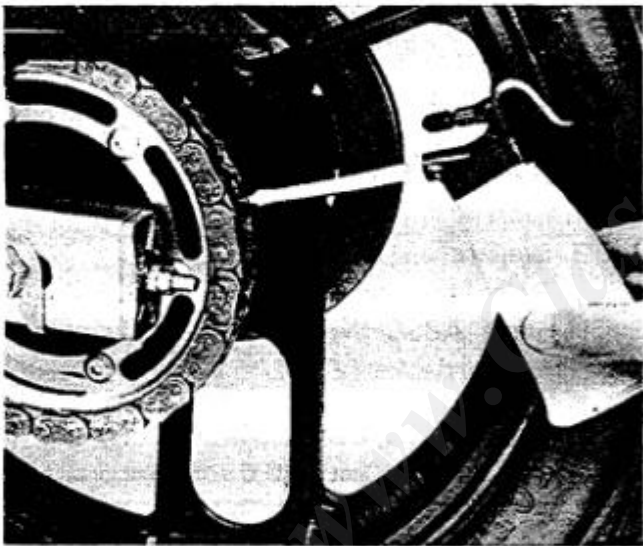
**CAUTION:**

Always use new cotter pins on the tension bar bolts.

DRIVE CHAIN LUBRICATION

The chain consists of many parts which work against each other. If the chain is not maintained properly, it will wear out rapidly, therefore, form the habit of periodically servicing the chain. This service is especially necessary when riding in dusty conditions.

This motorcycle has a drive chain with small rubber O-rings between the chain plates. Steam cleaning, high-pressure washes, and certain solvents can damage these O-rings. Use only kerosene to clean the drive chain. Wipe it dry, and thoroughly lubricate it with SAE 30 ~ 50W motor oil. Do not use any other lubricants on the drive chain. They may contain solvents that could damage the O-rings ①.

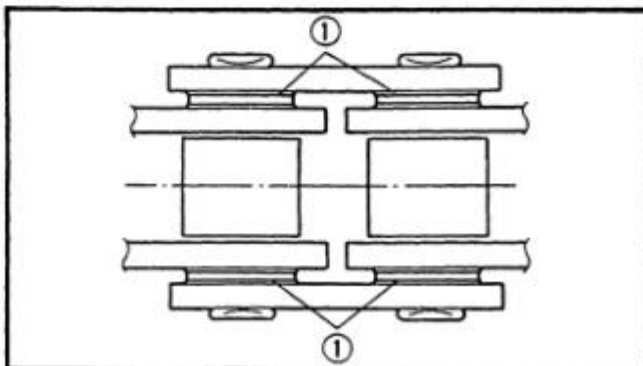

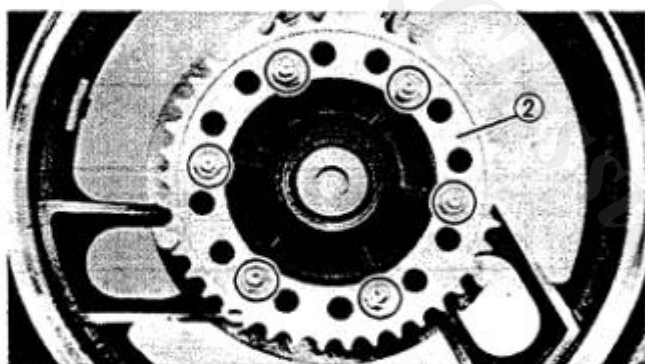
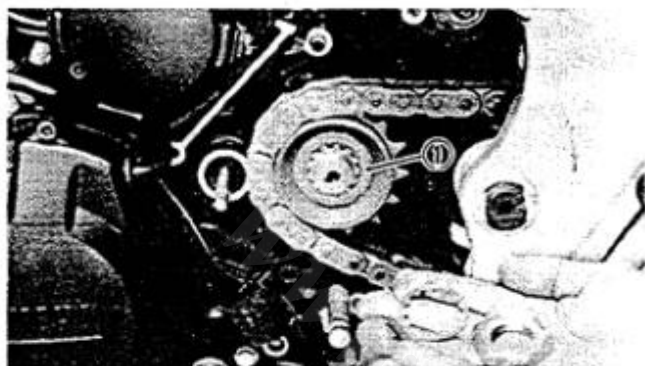
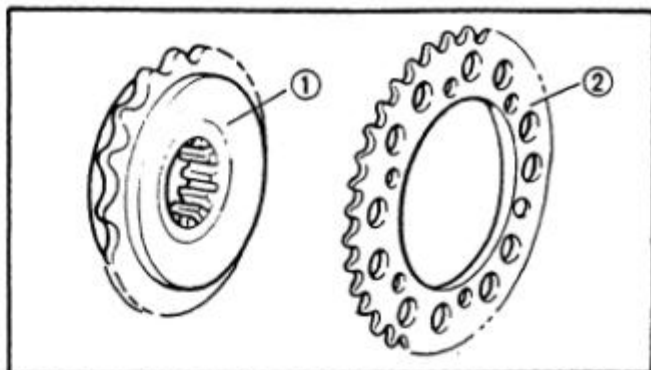

DRIVE AND DRIVEN CHAIN SPROCKETS

1. Inspect:
 - Sprocket teeth
 - Wear/Bends/Damage → Replace.

NOTE: _____
 Replace the sprockets and drive chain as a set.

- ① Drive sprocket
- ② Driven sprocket

2. Remove:
 - Drive sprocket ①
 - Driven sprocket ②
3. Install:
 - Drive sprocket (with a new lock washer)
 - Driven sprocket
4. Tighten:
 - All bolts and nuts



Drive Chain Sprocket:
 90 Nm (9.0 m·kg, 65 ft·lb)

Sprocket Cover:
 10 Nm (1.0 m·kg, 7.2 ft·lb)

Driven Chain Sprocket:
 32 Nm (3.2 m·kg, 23 ft·lb)

LOCTITE®

Rear Axle:
 105 Nm (10.5 m·kg, 75 ft·lb)

Locknut (Rear Axle):
 60 Nm (6.0 m·kg, 43 ft·lb)

FRONT AND REAR BRAKE

AIR BLEEDING

WARNING: _____

- Bleed the brake system if:
- The system has been disassembled.
 - A brake hose has been loosened or removed.
 - The brake fluid is very low.
 - The brake operation is faulty.
- A dangerous loss of braking performance may occur if the brake system is not properly bled.

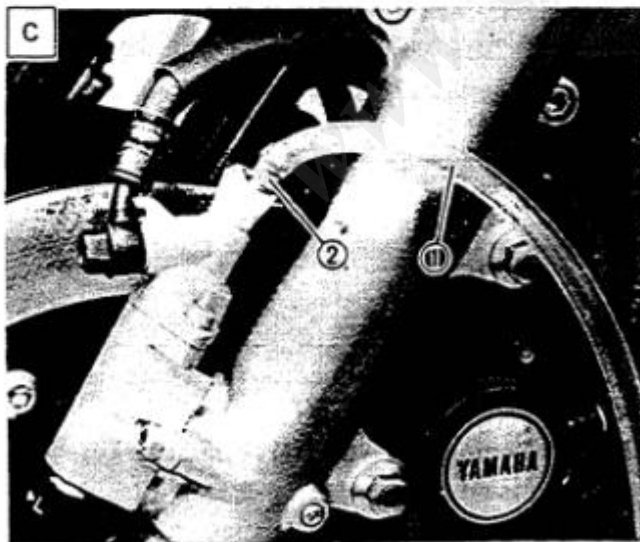
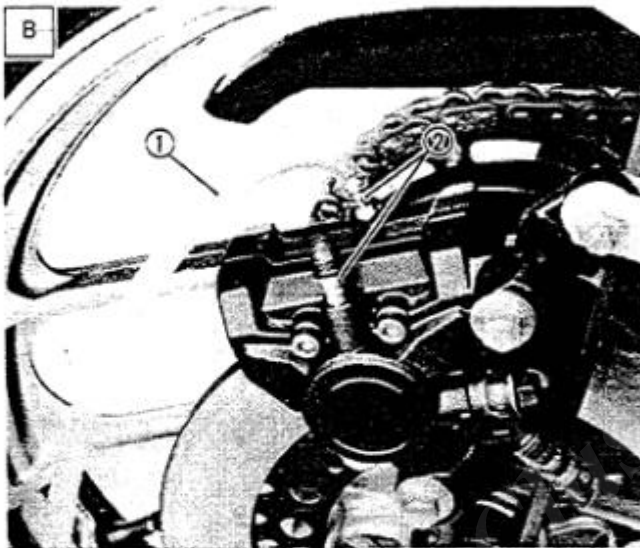
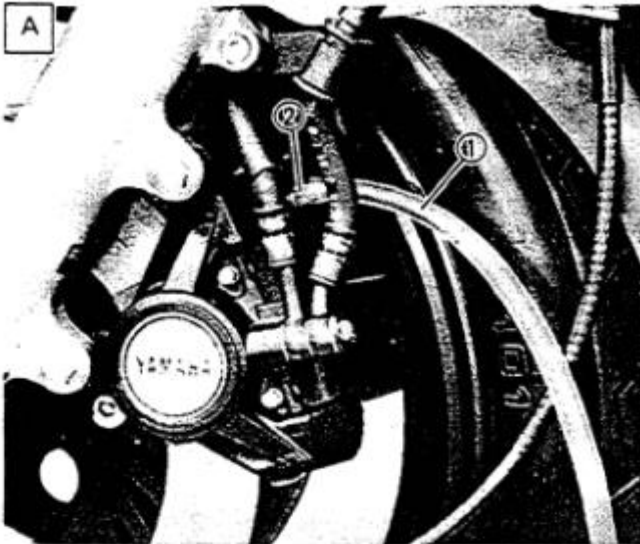
**Air bleeding steps:**

- Add proper brake fluid to the reservoir.
- Install the master cylinder cap. Be careful not to spill any fluid or allow the reservoir to overflow.
- Connect the clear plastic tube (4.5 mm 3/16 in inside dia.) ① tightly to the caliper bleed screw.
- Place the other end of the tube into a container.
- Slowly apply the brake lever or **pedal** several times.
- Pull the lever in or push down on the pedal. Hold the lever or pedal in position.
- Loosen the bleed screw ② and allow the lever or pedal to travel towards its limit.
- Tighten the bleed screw when the lever or pedal limit has been reached; then release the lever or pedal.
- Repeat the same steps until all of the air bubbles have been removed from the system.

**Bleed Screw:****6 Nm (0.6 m·kg, 4.3 ft·lb)****NOTE:**

If bleeding is difficult, it may be necessary to let the brake fluid system stabilize for a few hours. Repeat the bleeding procedure when the tiny bubbles in the system have disappeared.

**Brake Fluid:****DOT # 3**

- A** FRONT
- A** REAR
- C** ANTI-DIVE



CALIPER PAD REPLACEMENT (FRONT)

1. Pin
2. Clip
3. Rubber cap
4. Bleed screw
5. Pad spring
6. Piston seal
7. Piston
8. Disc pad
9. Arrow mark

NOTE:

- Install the pad spring with its longer tangs * facing towards the disc rotation direction.
- Be sure to position the disc so its arrow mark ⑨ points in the direction of the wheel rotation.

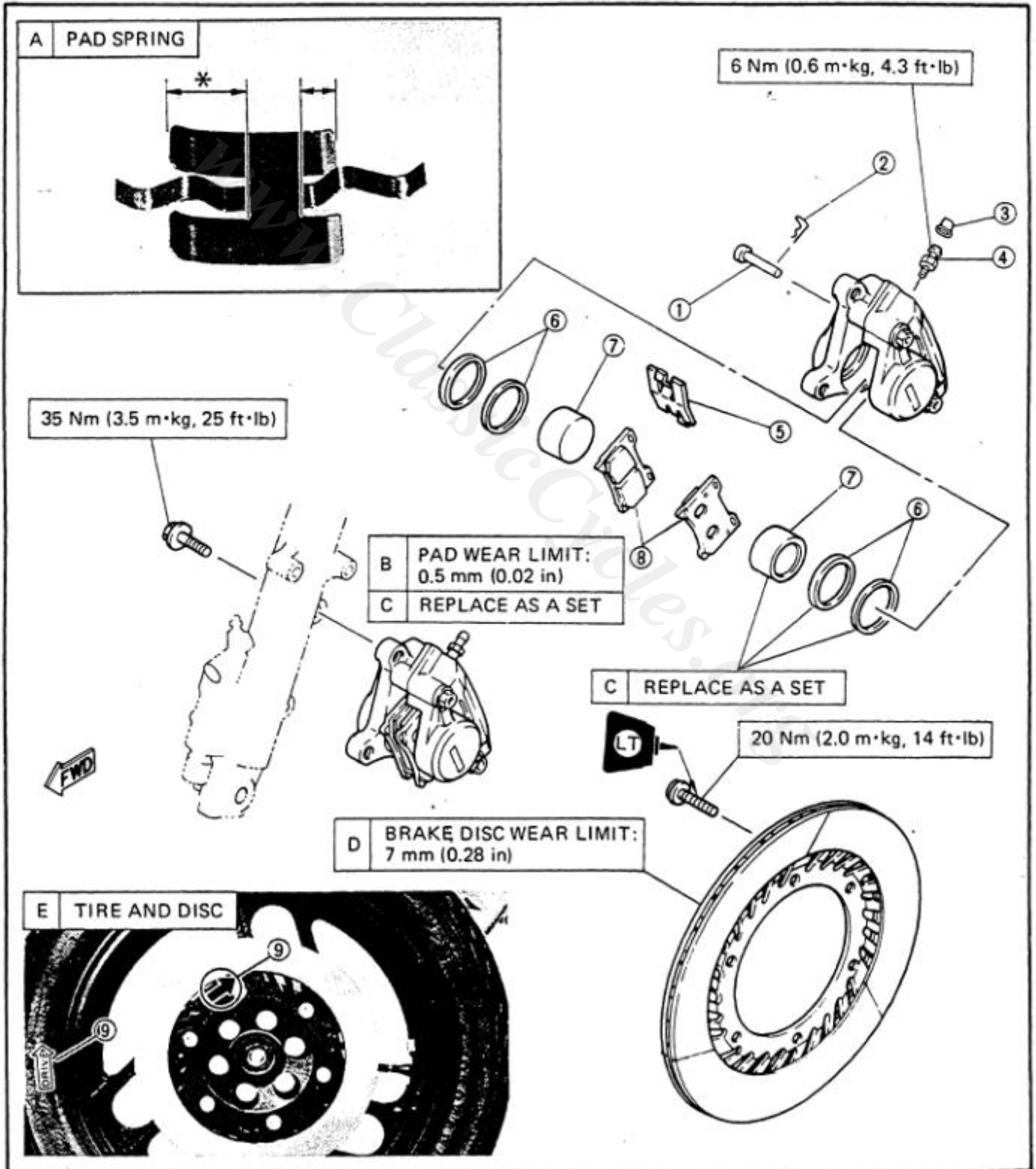



Brake Inspection and Repair

Recommended Brake Component Replacement Schedule:	
Brake pads	As required
Piston seal, dust seal	Every two years
Brake hoses	Every four years
Brake fluid	Replace only when brakes are disassembled

Caliper Pad Replacement

Front Brake:

NOTE:

It is not necessary to disassemble the brake caliper and brake hose to replace the brake pads.

1. Remove:
 - Cover ①
2. Remove
 - Retaining clips ②
 - Retaining pins ③
 - Pad spring ④
3. Remove:
 - Pads
4. Measure:
 - Pads

Out of specification → Replace.

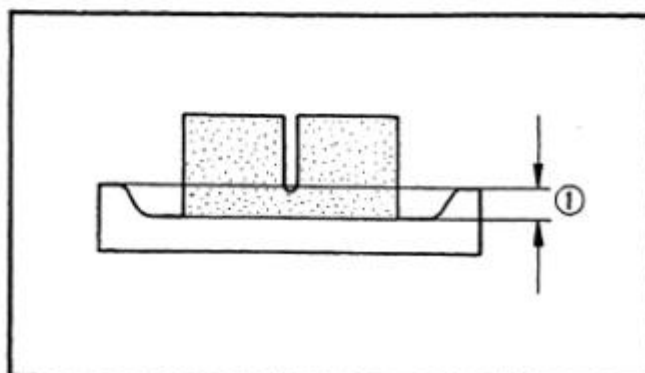
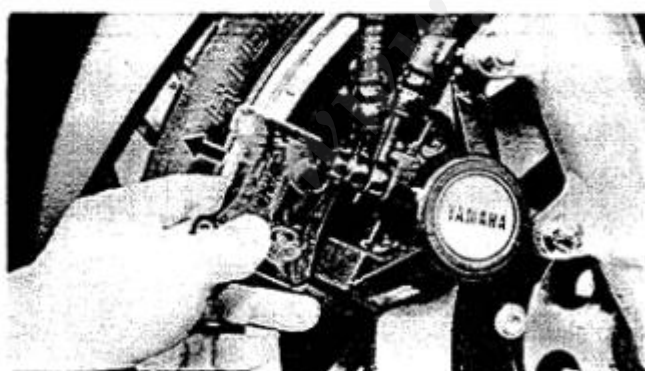
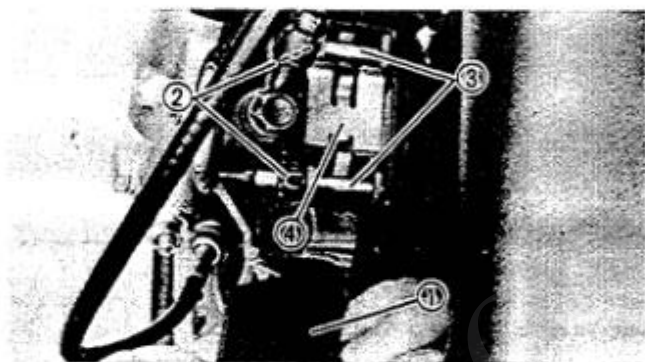

	<p>Pad Wear Limit ①: 0.5 mm (0.02 in)</p>
--	--

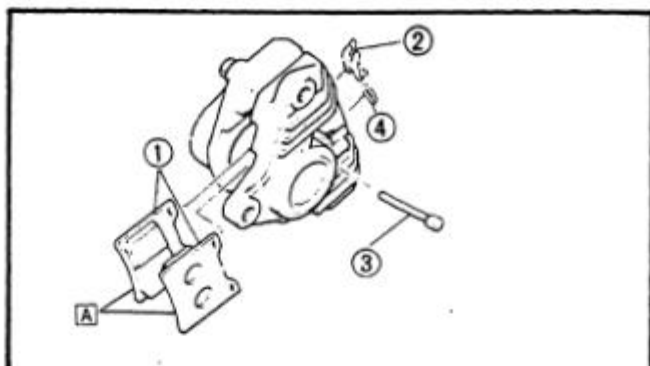

5. Install:
- Pads (New) ①
 - Pad spring ②
 - Retaining pins ③
 - Clips ④
 - Cover

A REPLACE AS A SET

NOTE: _____
Install the pad spring with its longer tangs * facing towards the disc rotation direction.

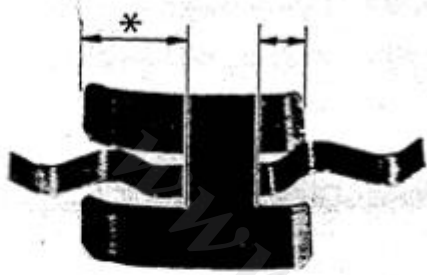

ClassicCycles.org

CALIPER PAD REPLACEMENT (REAR)

1. Retaining bolt
2. Rubber cap
3. Bleed screw
4. Pad spring
5. Piston seal
6. Piston
7. Shim
8. Disc pad

A DRIVE DIRECTION

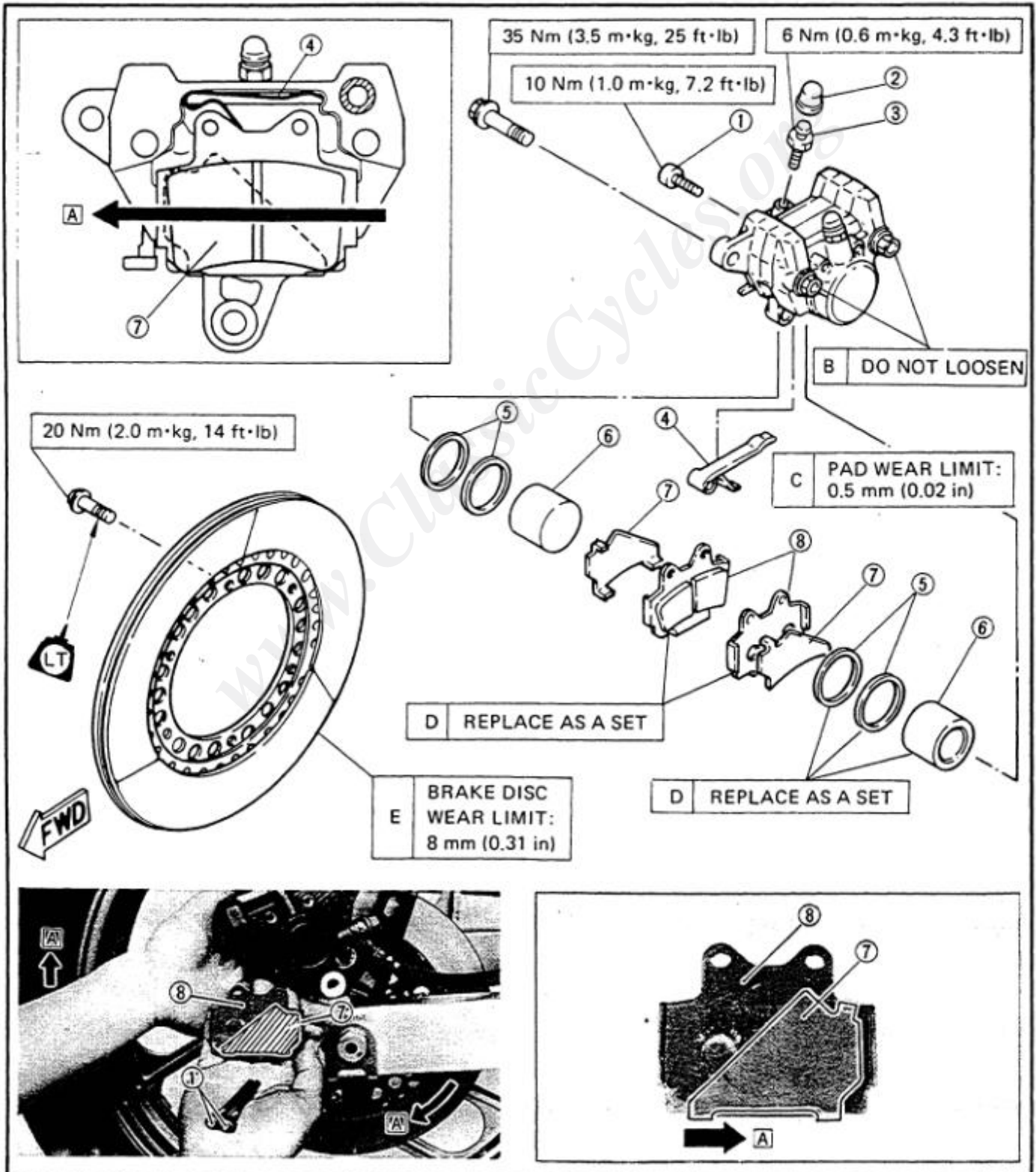

Brake Inspection and Repair

Recommended Brake Component Replacement Schedule:	
Brake pads	As required
Piston seal, dust seal	Every two years
Brake hoses	Every four years
Brake fluid	Replace only when brakes are disassembled

Caliper Pad Replacement

Rear Brake:

1. Remove:
 - Caliper
 - Retaining bolts ①

2. Remove:
 - Pads ①

- ② Retaining bolt
3. Measure:
 - Pads

Out of specification → Replace.

NOTE: _____
 Replace the pads as a set if either is found to be worn to the wear limit.

	<p>Pad Wear Limit ①: 0.5 mm (0.02 in)</p>
---	---

4. Install:
 - Pads (New)
 - Retaining bolts

A DRIVE DIRECTION

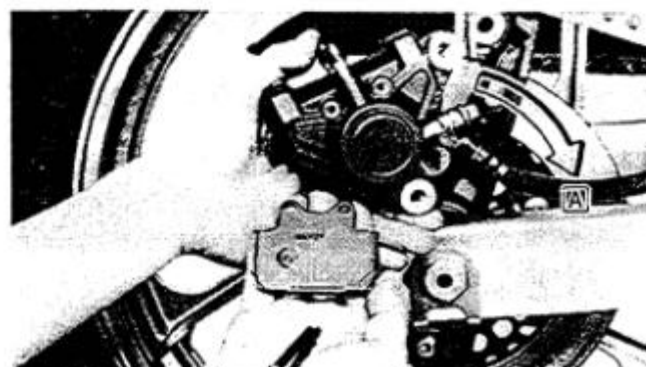
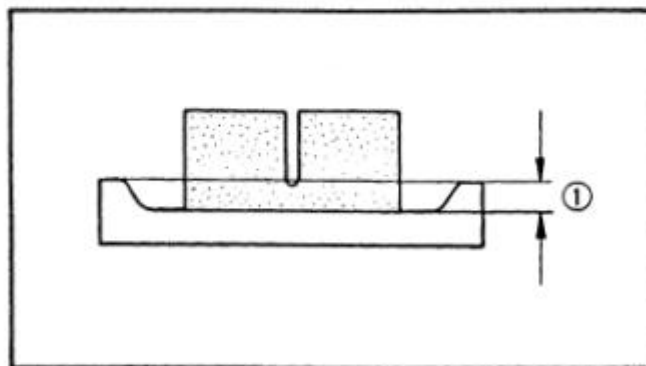
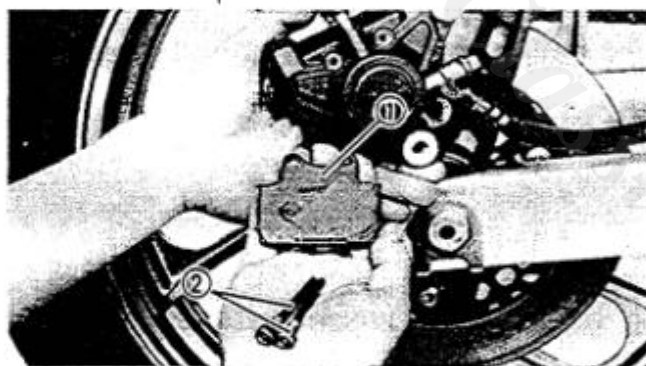
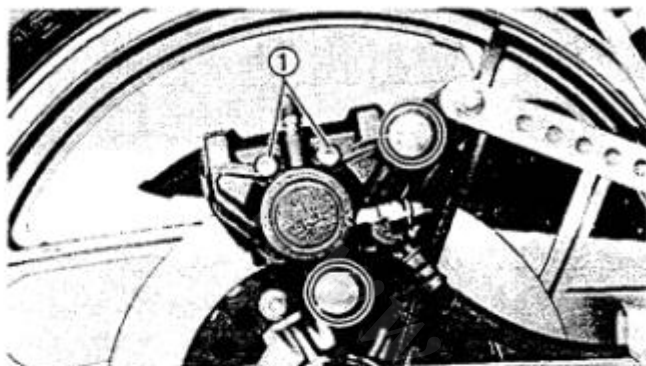

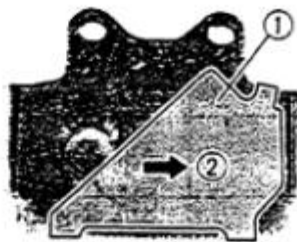

NOTE:
Insert the pads with their shims ① in the direction of the arrow ②.

5. Tighten:
 - Caliper
 - Retaining bolts



Caliper:
35 Nm (3.5 m·kg, 25 ft·lb)
Retaining Bolt:
10 Nm (1.0 m·kg, 7.2 ft·lb)

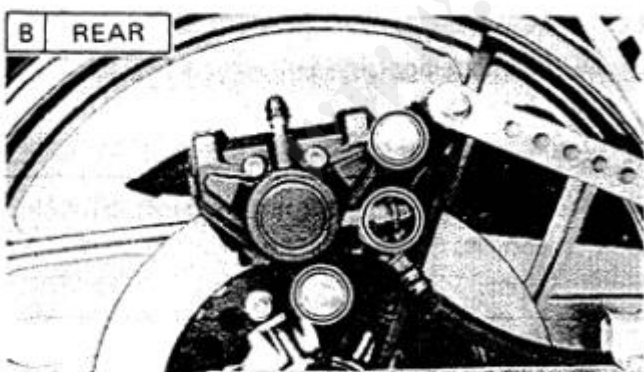
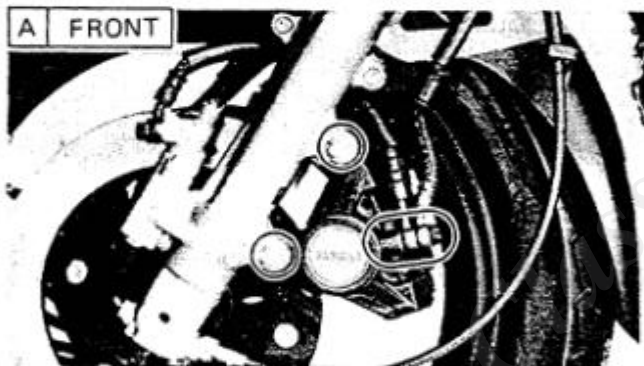
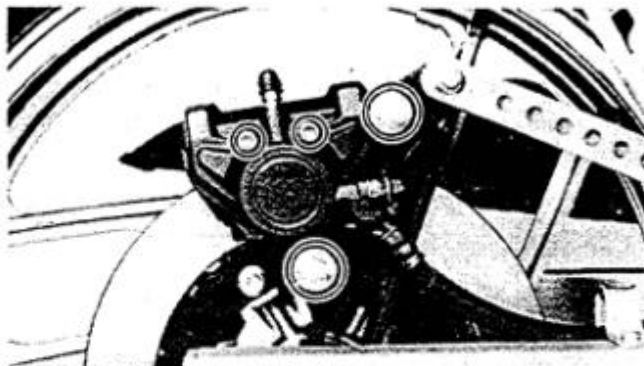

CALIPER DISASSEMBLY (FRONT AND REAR)

Disassembly

1. Remove:
 - Pads
 - Brake hoses
Place the open hose end into a container and pump the old fluid out carefully.
 - Caliper
2. Remove:
 - Brake hose
Place the open hose end into a container and pump the old fluid out carefully.
 - Caliper
 - Pads

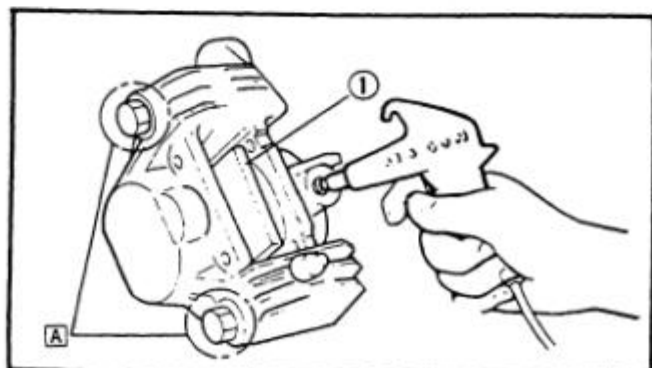

Caliper piston removal steps:

- Insert a piece of wooden board ① into the caliper to lock the right side piston.
- Blow compressed air into the hose joint opening to force out the left side piston from the caliper body.
- Repeat previous step to force out the right side piston from the caliper body.

A DO NOT LOOSEN

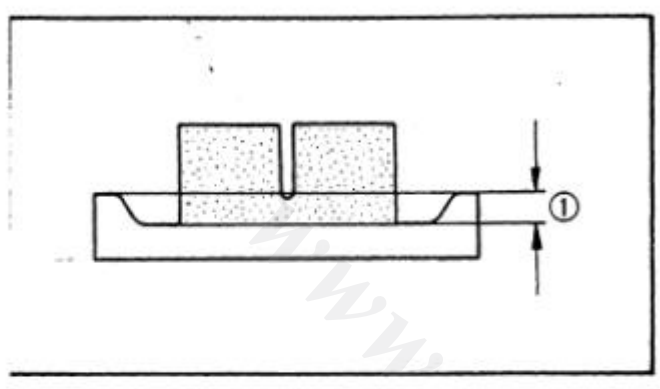
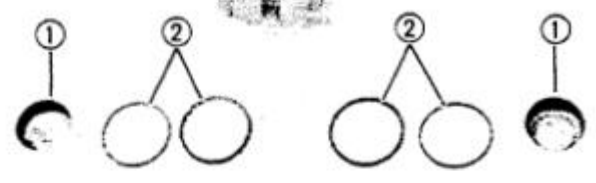
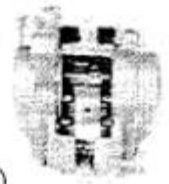

3. Remove:
 - Pistons ①
 - Piston seals ②

Inspection

1. Inspect:
 - Caliper piston
Rust/Wear → Replace.
 - Brake pads
Out of specification → Replace.

	Pad Wear Limit ①: 0.5 mm (0.02 in)
---	--

WARNING:

- All internal parts should be cleaned in new brake fluid only.
- Internal parts should be lubricated with brake fluid when installed.

	Brake Fluid: DOT #3
---	-------------------------------

- Replace the piston and piston seals whenever a caliper is disassembled.

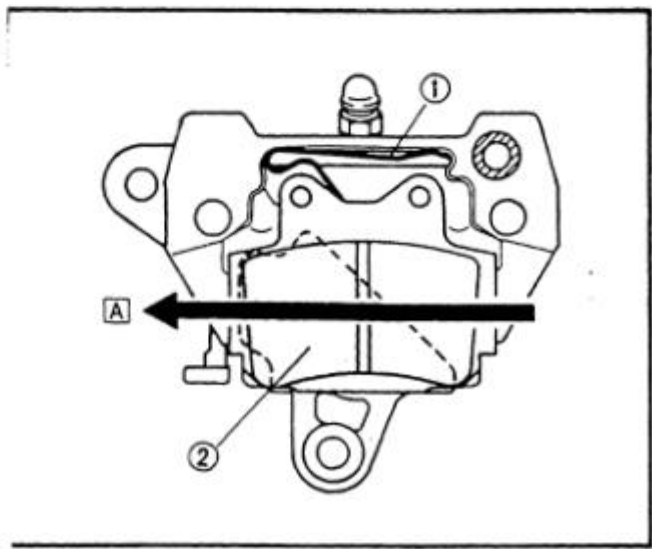

Installation

1. Assemble:
 - Brake caliper(s)
Reverse disassembly steps.
2. Install:
 - Brake calipers
 - Hoses

- ① Pad spring
- ② Shim
- A DRIVE DIRECTION

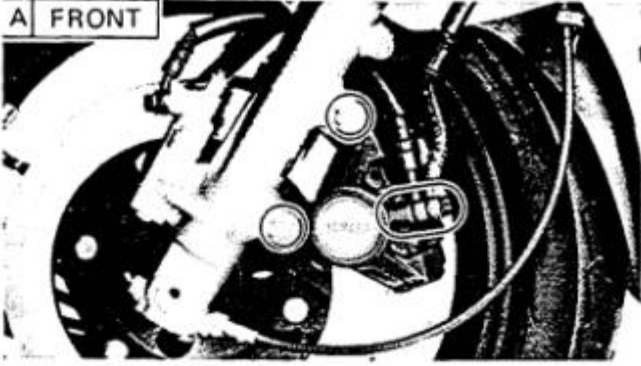
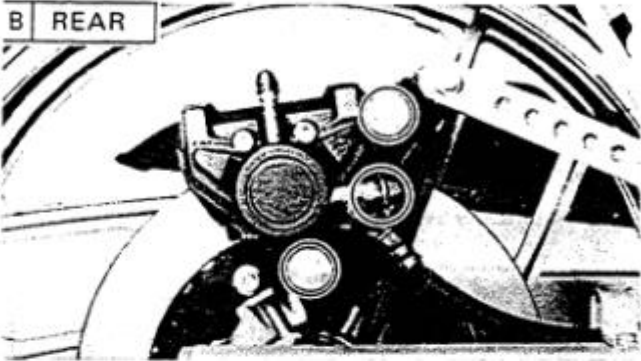
A FRONT**B REAR**

3. Tighten:
 - Caliper bolts
 - Hose union bolts (with copper washers)

**FRONT AND REAR:****Brake Caliper:**

35 Nm (3.5 m·kg, 25 ft·lb)

Brake Hose:

26 Nm (2.6 m·kg, 19 ft·lb)

4. Bleed the air completely from the brake system.

www.ClassicCycles.org



BRAKE MASTER CYLINDER (FRONT)

1. Master cylinder cap
2. Rubber seal
3. Master cylinder kit
4. Copper washer
5. Brake hose holder
6. Brake hose (to Anti-Dive)

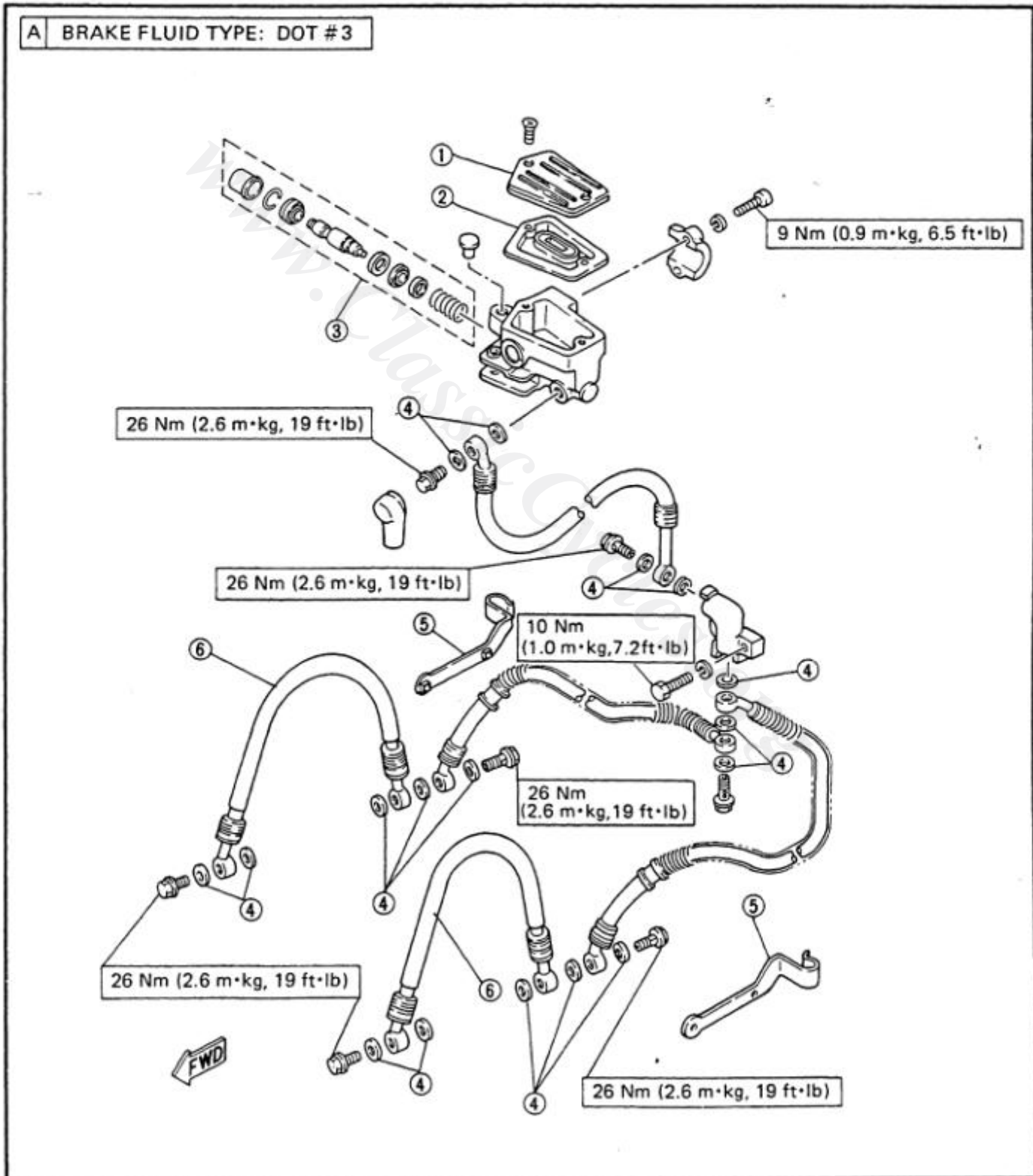

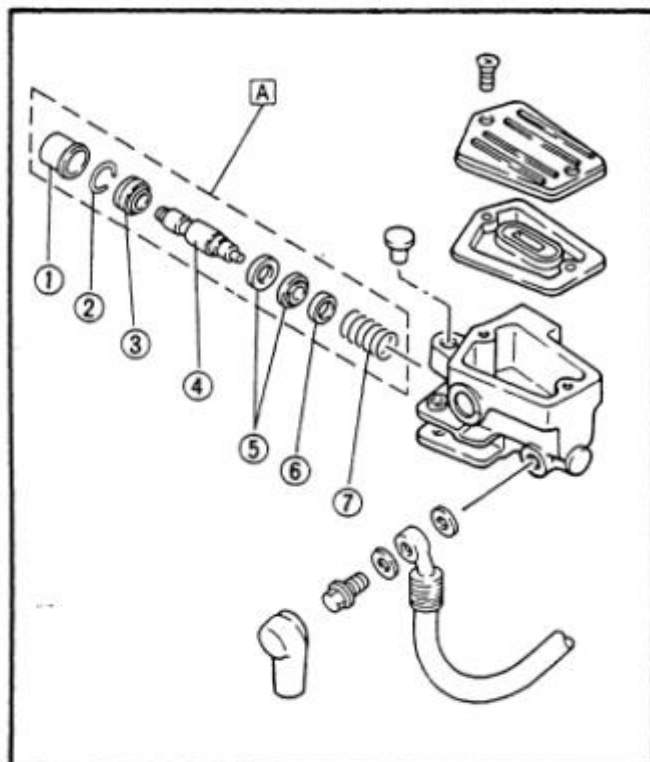

Master Cylinder Disassembly

Front Brake:

NOTE: _____
 Drain the brake fluid before removing master cylinder.

- ① Dust boot
- ② Circlip
- ③ Piston cover
- ④ Piston
- ⑤ Piston cups
- ⑥ Spring seat
- ⑦ Return spring
- A** MASTER CYLINDER KIT (Replace as a set)

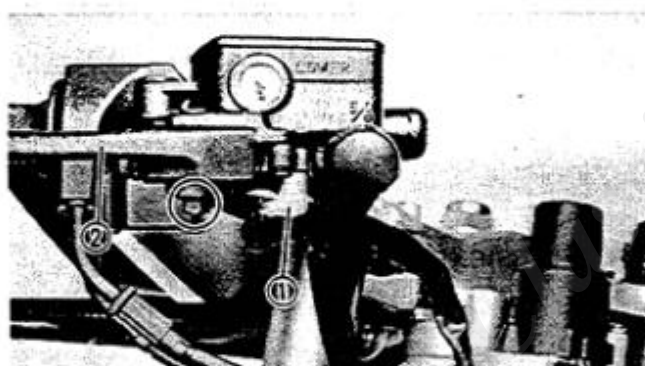

1. Remove:
 - Brake light switch leads ①
 - Brake lever ②
 - Lever spring
2. Disconnect:
 - Brake hose
 - Drain the fluid.

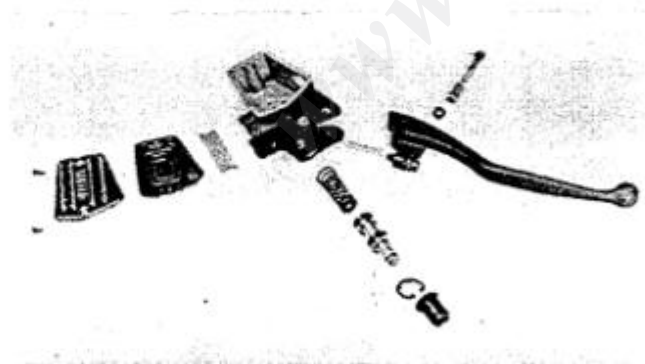

3. Remove:
 - Master cylinder
 - Master cylinder cap
 - Drain the excess fluid.
 - Dust boot
 - Circlip
 - Master cylinder kit

Inspection

1. Inspect:
 - Master cylinder body
 - Scratches/Wear → Replace.

NOTE: _____
 Clean all passages with new brake fluid.

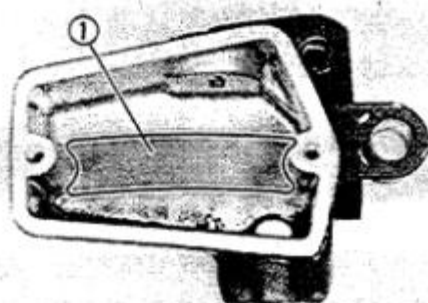

- ① Oil baffle plate



2. Inspect
 - Brake hoses
Cracks/Wear/Damage → Replace.
 - Master cylinder kit
Scratches/Wear → Replace.

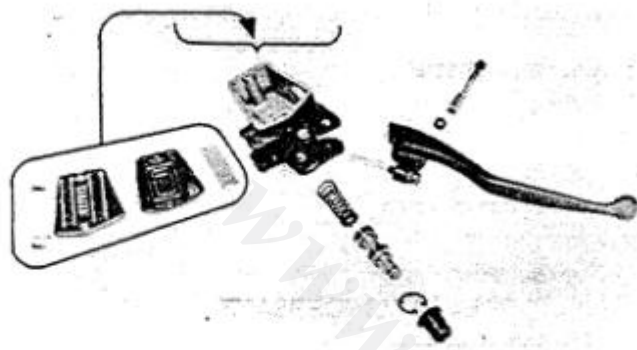

Installation

1. Install:
 - Master cylinder kit

WARNING:

Internal ports should be lubricated with brake fluid when installed.

- Circlip
- Dust boot
2. Install:
 - Master cylinder
 - Brake hose (with copper washers)
 - Brake lever

NOTE:

Grease the pivot point.

- Brake switch leads

3. Tighten:
 - Master cylinder bolts
 - Brake hose



Master Cylinder:

9 Nm (0.9 m·kg, 6.5 ft·lb)

Brake Hose:

26 Nm (2.6 m·kg, 19 ft·lb)

4. Bleed the air completely from the brake system.
5. Tighten:
 - Master cylinder cap



Master Cylinder Cap:

2 Nm (0.2 m·kg, 1.4 ft·lb)

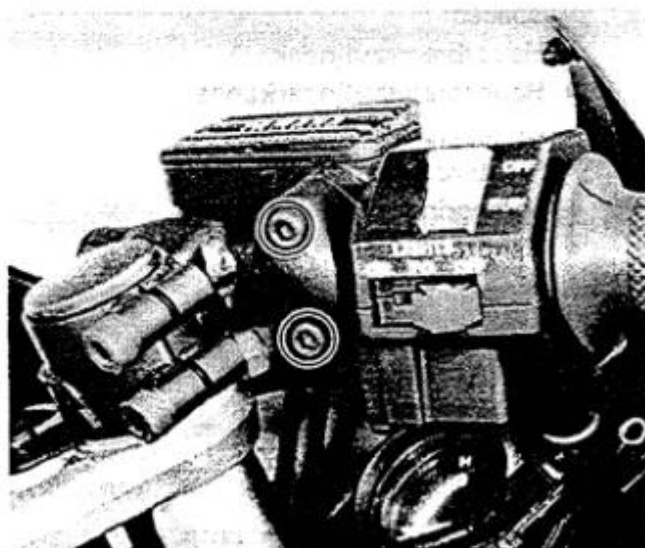

BRAKE MASTER CYLINDER (REAR)

1. Reservoir tank
2. Band
3. Copper washer
4. Master cylinder kit
5. Adjusting rod (For brake pedal height)
6. 50 ~ 60 mm (2.0 ~ 2.4 in)
7. O-ring

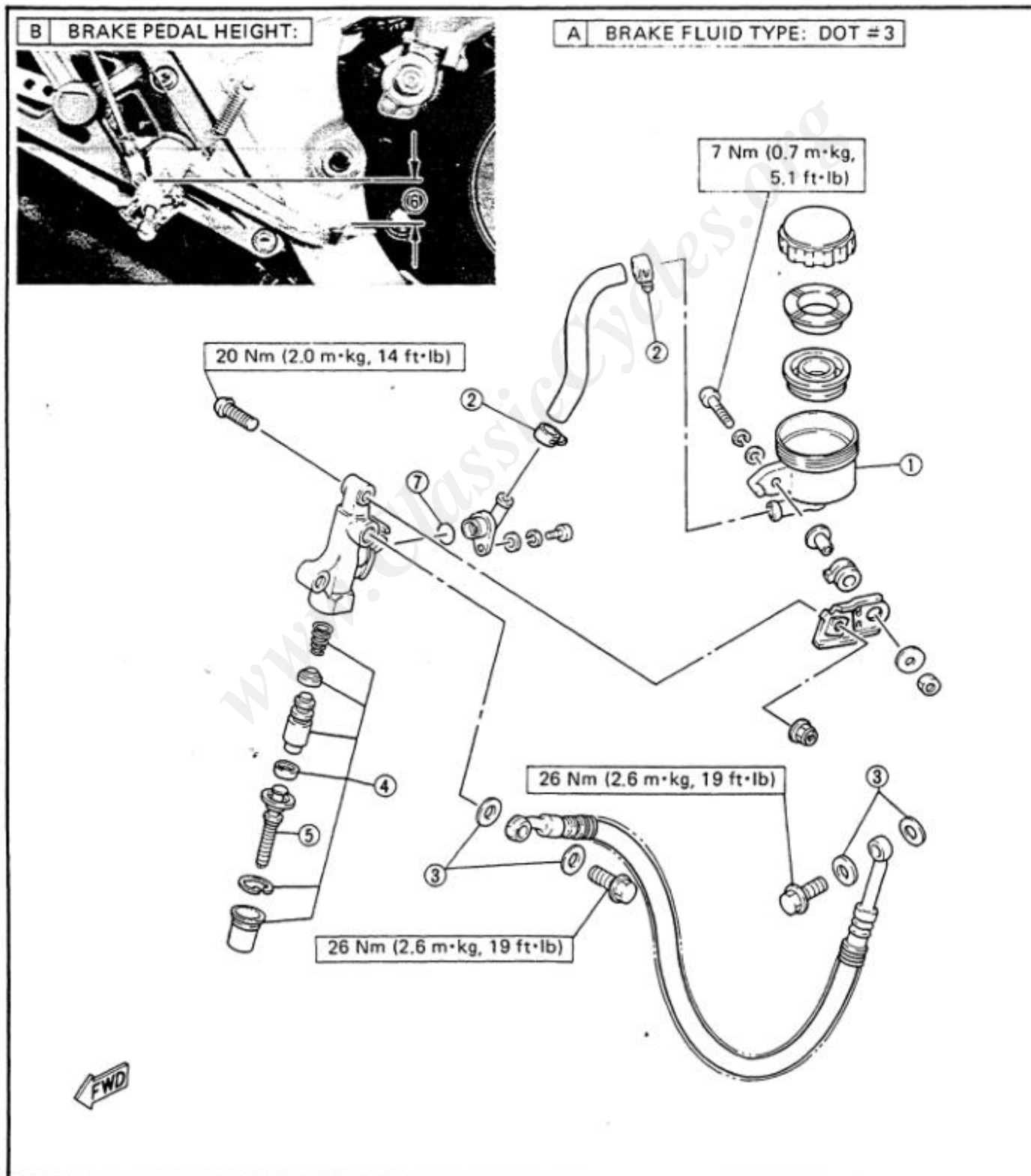

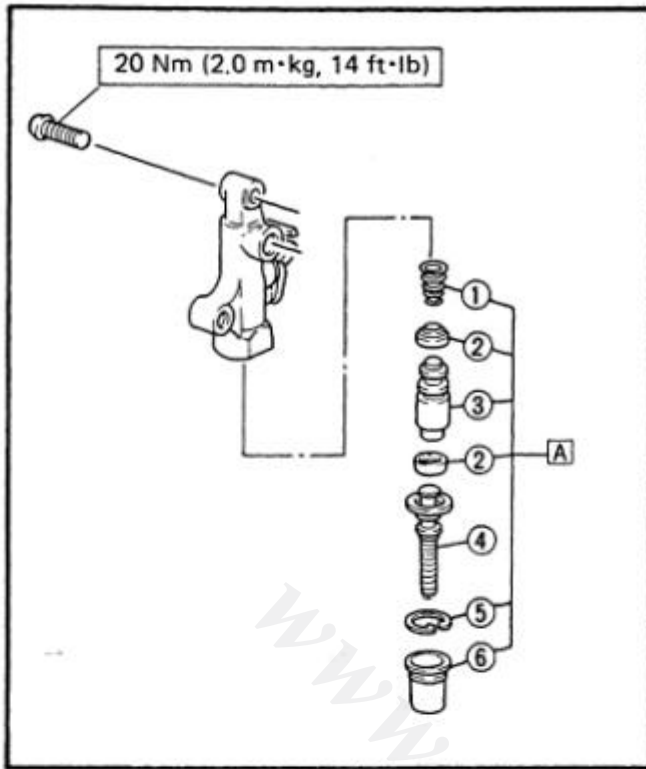

Master Cylinder Disassembly

Rear Brake:

NOTE: _____
 Drain the brake fluid before removing master cylinder.

1. Remove:
 - Side cover (Right)
2. Disconnect:
 - Brake hose

- ① Spring
- ② Piston cup
- ③ Piston
- ④ Adjusting rod
- ⑤ Circlip
- ⑥ Dust boot
- A** MASTER CYLINDER KIT (Replace as a set)

3. Remove:
 - Master cylinder
 - Fluid reservoir tank
4. Disconnect:
 - Tank hose

5. Remove:
 - Dust boot ①
 - Circlip ②
 - Adjusting rod ③
 - Master cylinder kit ④
 Drain the excess fluid.

Inspection

1. Inspect:
 - Master cylinder body
 Scratches/Wear → Replace.

NOTE: _____
 Clean all passages with new brake fluid.

- Brake hoses
 Cracks/Wear/Damage → Replace.
- Master cylinder kit
 Scratches/Wear → Replace.

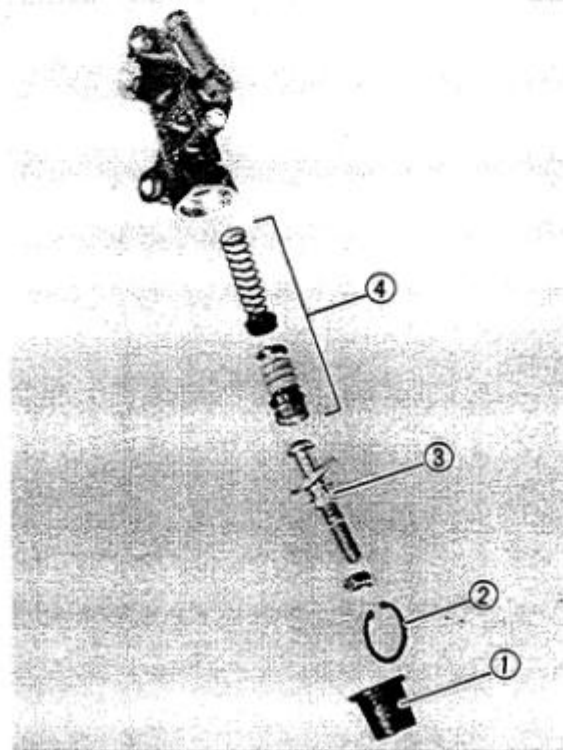

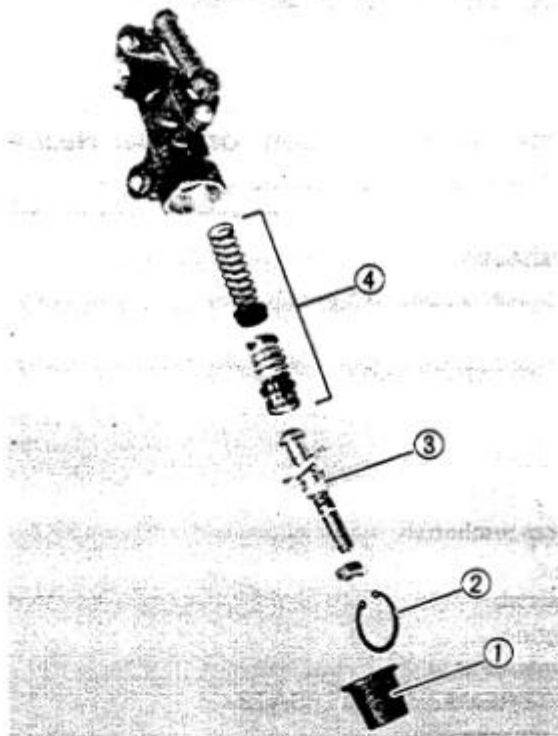

Installation

1. Install:
 - Master cylinder kit ④

WARNING:

Internal parts should be lubricated with brake fluid when installed.

- Adjusting rod ③
 - Circlip ②
 - Dust boot ①
2. Install:
 - Master cylinder
 - Fluid reservoir tank
 - Brake hose (with copper washers)
3. Tighten:
 - Master cylinder
 - Fluid reservoir tank
 - Brake hose



Master Cylinder:

20 Nm (2.0 m·kg, 14 ft·lb)

Fluid Reservoir Tank:

7 Nm (0.7 m·kg, 5.1 ft·lb)

Brake Hose:

26 Nm (2.6 m·kg, 19 ft·lb)

4. Bleed the air completely from the brake system.

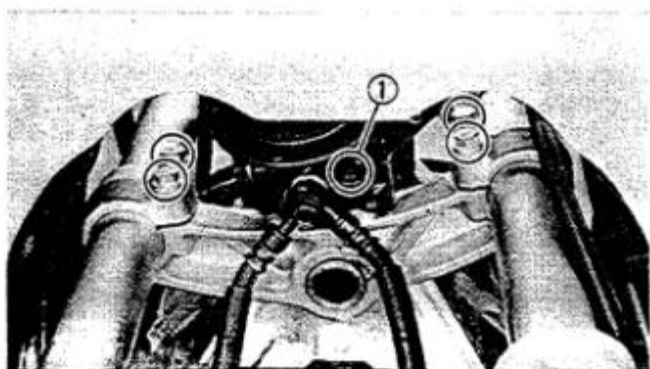
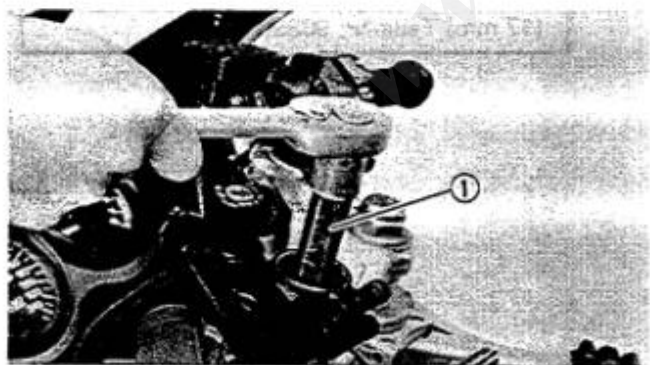
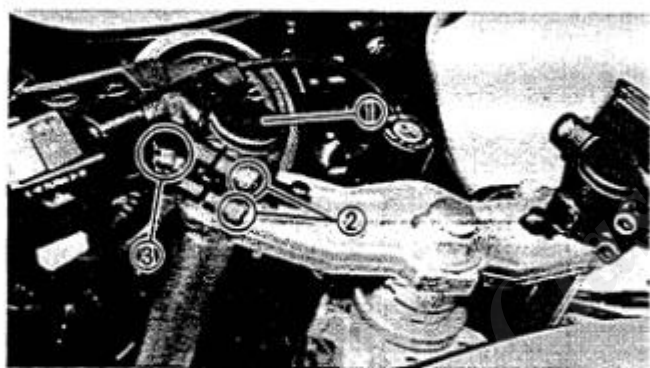
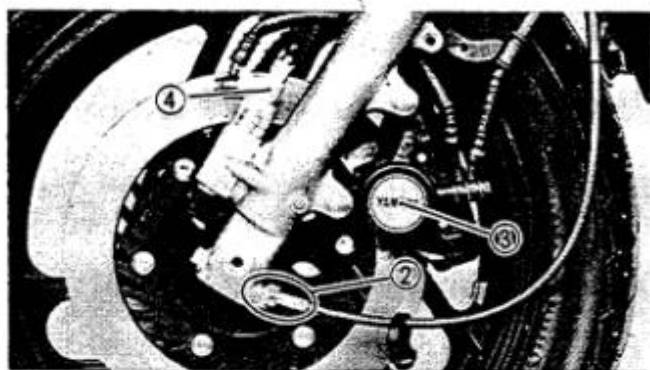
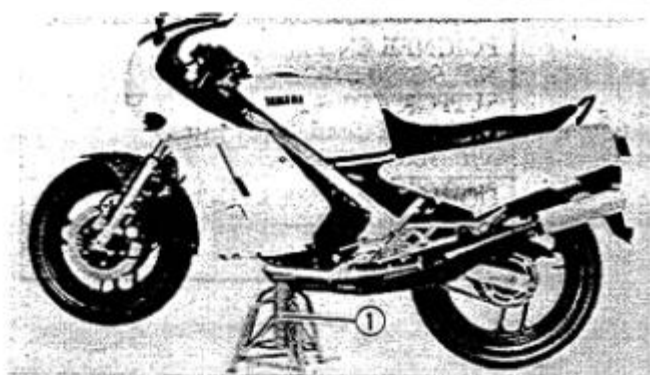

REMOVAL

1. Remove:
 - Lower cowling
2. Place the motorcycle on a block or other suitable stand ① under the frame.

WARNING:

Securely support the motorcycle so it won't fall over when the front wheel and front forks are removed.

3. Remove:
 - Front fender
 - Speedometer cable ②
 - Brake calipers ③
 - Plunger case ④
 - Front wheel
4. Remove:
 - Fork caps ①
5. Loosen:
 - Pinch bolts (Handlebar) ②
 - Pinch bolts ③
6. Loosen:
 - Cap bolt
Use the Front Fork Cap Socket 17 mm (90890-01104) ①.
7. Remove:
 - Brake hose joint ①
8. Loosen:
 - Pinch bolts (Underbracket)
9. Remove:
 - Fork(s)

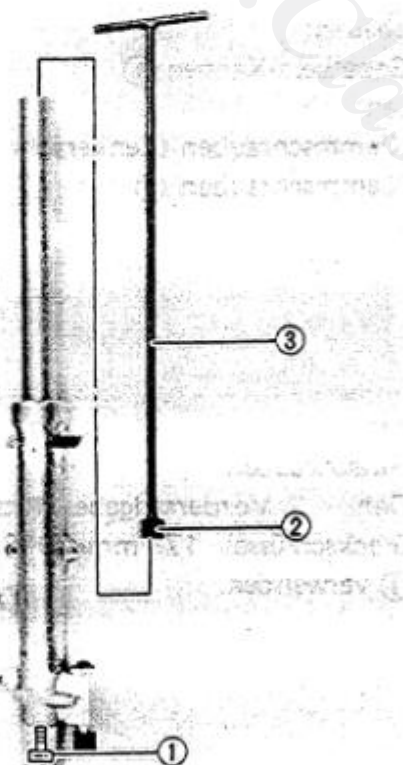
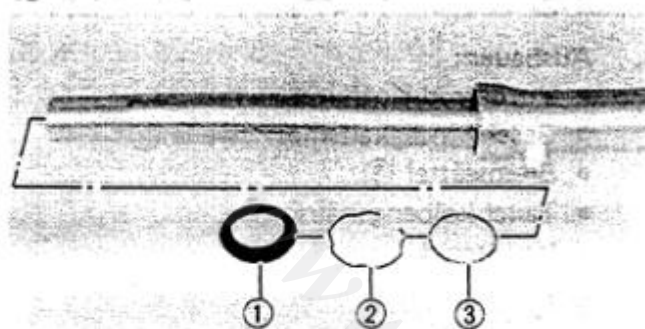
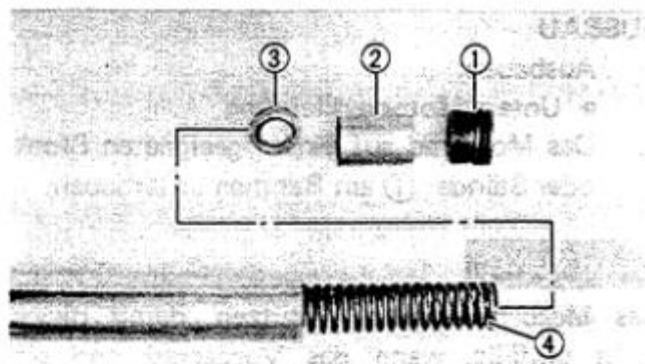

DISASSEMBLY

1. Remove:
 - Cap bolt ①
 - Collar ②
 - Spring seat ③
 - Fork spring ④
2. Drain:
 - Fork oil
3. Remove:
 - Dust seal ①

NOTE: _____
 Use a thin screwdriver, and be careful not to scratch the inner fork tube.

- Retaining clip ②
- Washer ③

4. Remove:
 - Cylinder securing bolt ①
 Use the Damper Rod Holder (90890-01388) ② and T-Handle (90890-01326) ③ to lock the damper rod.
 - Damper rod
 - Inner fork tube

Inner fork tube removal steps:

- Hold the fork leg horizontally.
- Clamp the axle mounting boss of the outer fork tube securely in a vise having soft jaws.
- Pull out the inner fork tube from the outer tube by forcefully, but carefully, withdrawing the inner fork tube.

NOTE: _____

- Excessive force will damage the oil seal, plate washer and/or bushings. The oil seal and bushings must be replaced.
- Avoid bottoming the inner tube in the outer tube during the above procedure, as the oil lock valve assembly will be damaged.

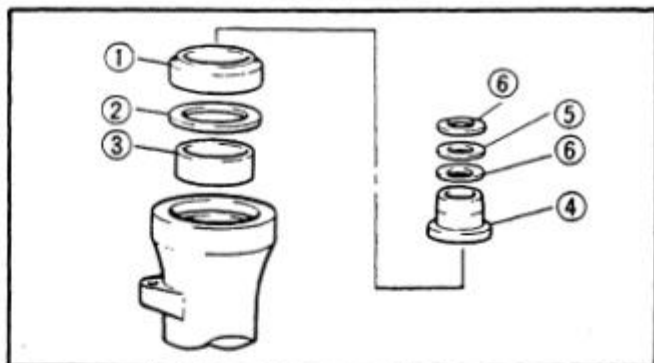

5. Remove:
- Oil seal ①
 - Plate washer ②
 - Guide bushing ③
 - Taper spindle ④
 - Plate washer ⑤
 - Wave washers ⑥

INSPECTION

1. Inspect
- Inner fork tube ①
Scratches/Bends → Replace.

WARNING:

Do not attempt to straighten a bent inner fork tube as this may dangerously weaken the tube.

2. Inspect:
- Outer fork tube ②
Scratches/Bends/Damage → Replace.
 - Fork spring ③
Out of specification → Replace.

	Fork Spring Free Length:
	498 mm (19.6 in)
	Minimum Free Length:
	493 mm (19.4 in)

3. Inspect:
- Damper rod ④
Wear/Damage → Replace.

NOTE:

Blow out all oil passages with compressed air.

4. Inspect:
- O-ring ⑤
Wear/Cracks/Damage → Replace.

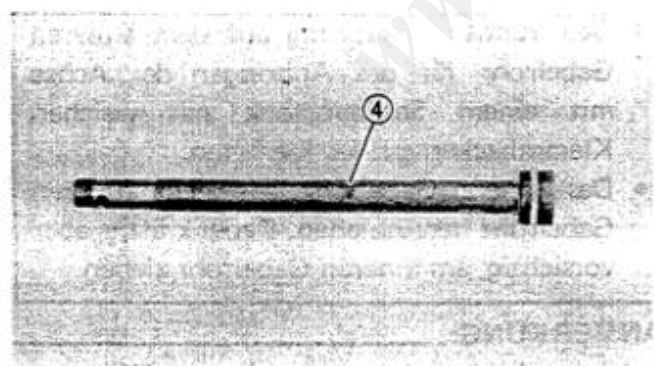
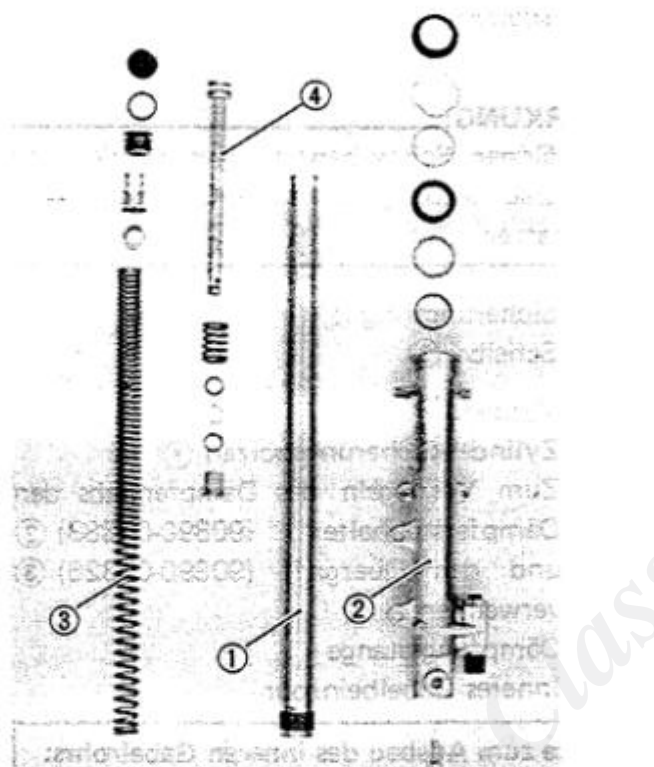

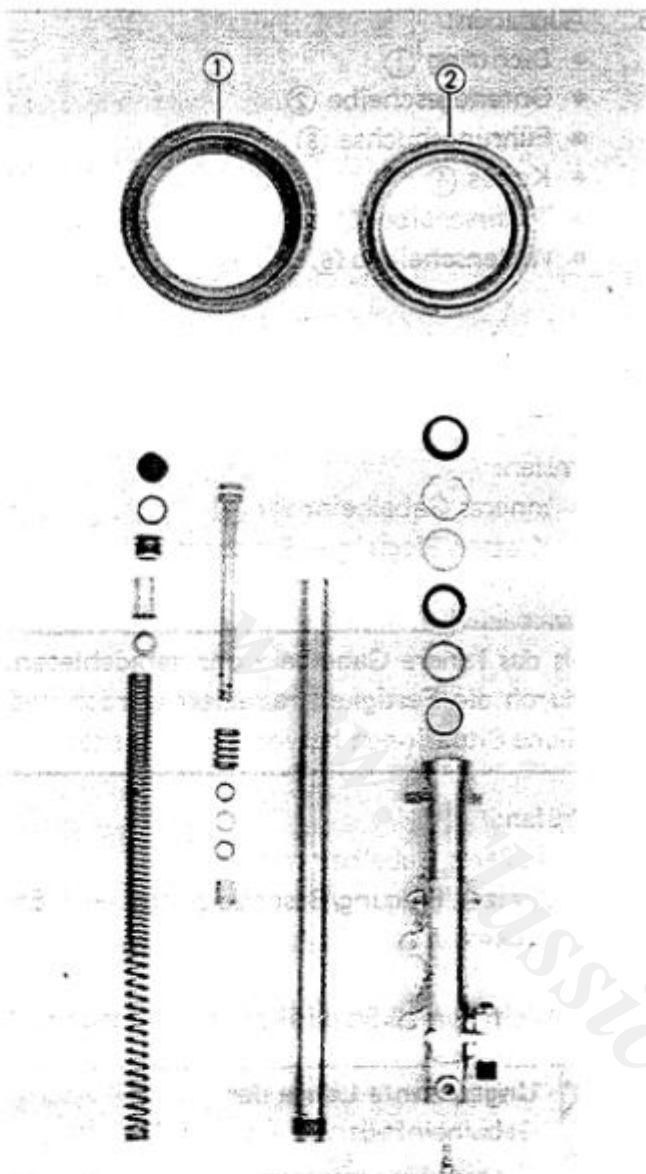

5. Inspect:

- Seals
- Wear/Damage → Replace.

① Dust seal

② Oil seal

REASSEMBLY

NOTE:

Make sure all components are clean before assembly. Always install the new oil seal, bushings, and the dust seal.

Do not reuse them.

1. Install:

- Damper rod
- Inner fork tube

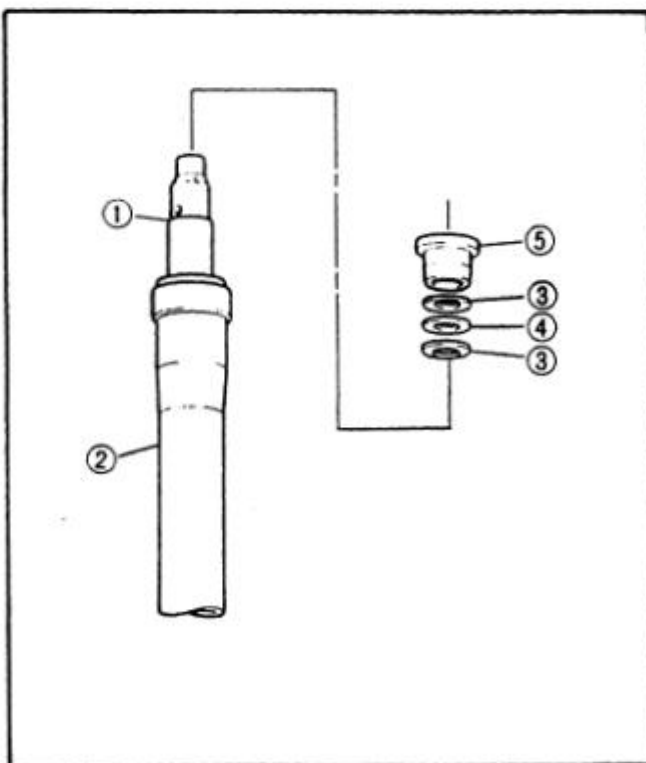

Fork assembly steps:

- Install the rebound spring onto the damper rod.
- Install the slide bushing onto the inner fork tube.
- Install the damper rod ① in the inner fork tube ②, and allow it to slide slowly down the tube until it protrudes from the bottom.
- Attache the Damper Rod Holder and T-Handle to lock the damper rod.
- Hold the inner fork tube ②, and turn it upside down.
- Install the wave washer ③, plate washer ④, and wave washer ③, in that order.
- Put the taper spindle ⑤ on the damper rod.

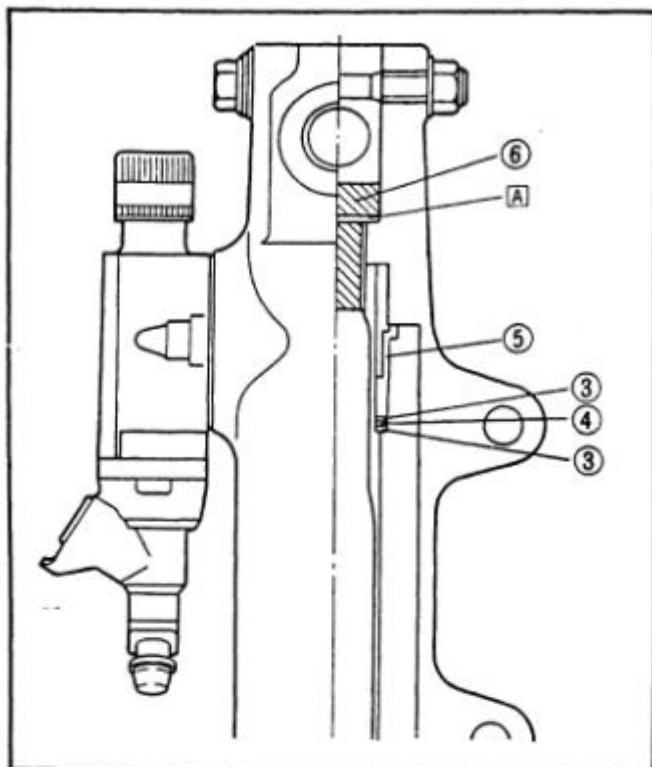

- Hold one hand over the top of the inner fork tube, and carefully install the outer fork tube over the taper spindle.
- Apply LOCTITE® to the damper rod securing bolt ⑥ and tighten the bolt to the specification: use the Damper Rod Holder (90890-01388) and T-Handle (90890-01326).



Damper Rod:
23 Nm (2.3 m·kg, 17 ft·lb)
LOCTITE®

A Copper washer

2. Install:

- Guide bushing ①
Use the Fork Seal Driver Weight (90890-01367) ② and Adapter (90890-01381) ③.
- Plate washer ④
- Oil seal ⑤
Use the Fork Seal Driver Weight (90890-01367) ② and Adapter (90890-01381) ③.
- Washer
- Circlip
- Dust seal

3. Fill

- Front fork



(Each):
300 cm³ (10.6 Imp oz, 10.1 US oz)
SAE 5W Type SE Motor Oil or
Equivalent
After filling, slowly pump the
fork up and down to distribute oil.

4. Install:

- Fork spring
(with smaller pitch side up)
- Spring seat
- Collar

- ⑥ Inner fork tube
- ⑦ Outer fork tube

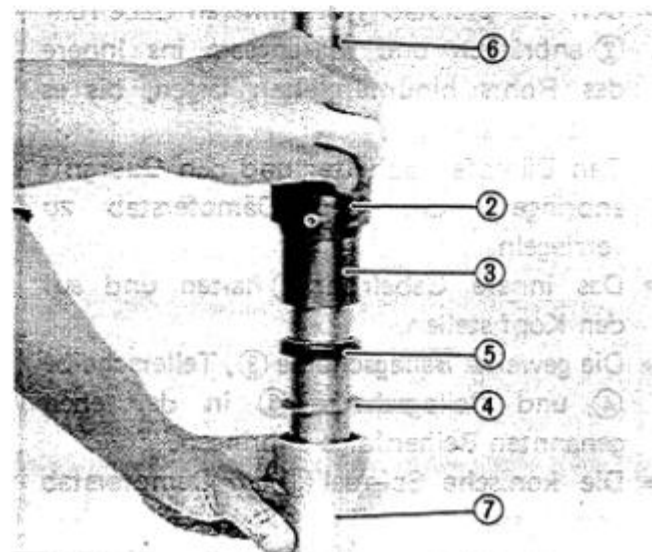
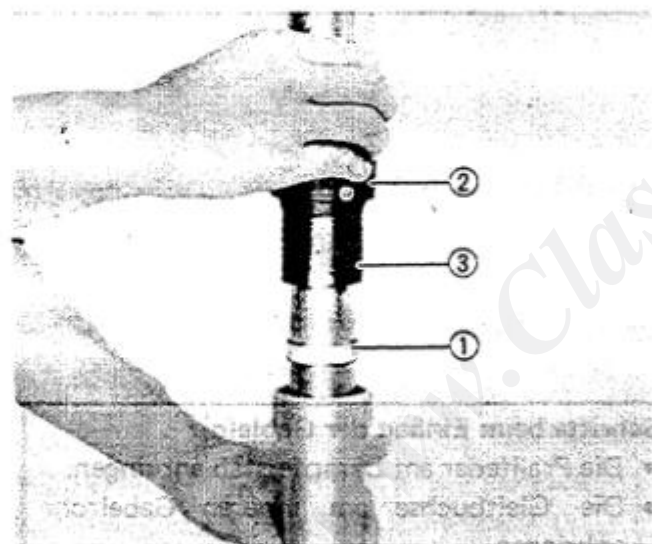

INSTALLATION

1. Install:
 - Front fork(s)
2. Tighten:
 - Pinch bolts (Underbracket)

	<p>Underbracket: 23 Nm (2.3 m·kg, 17 ft·lb)</p>
---	--

NOTE:
Do not tighten the steering crown pinch bolt.



3. Tighten:
 - Cap bolt assembly
 - Use the Front Fork Cap Socket (90890-01104) ①.

	<p>Cap Bolt: 23 Nm (2.3 m·kg, 17 ft·lb)</p>
---	--

4. Loosen:
 - Pinch bolts (Underbracket)
5. Install:
 - Front fork

NOTE:
Be sure the top end of the inner fork tube ③ is level with the top of the handlebar ②.

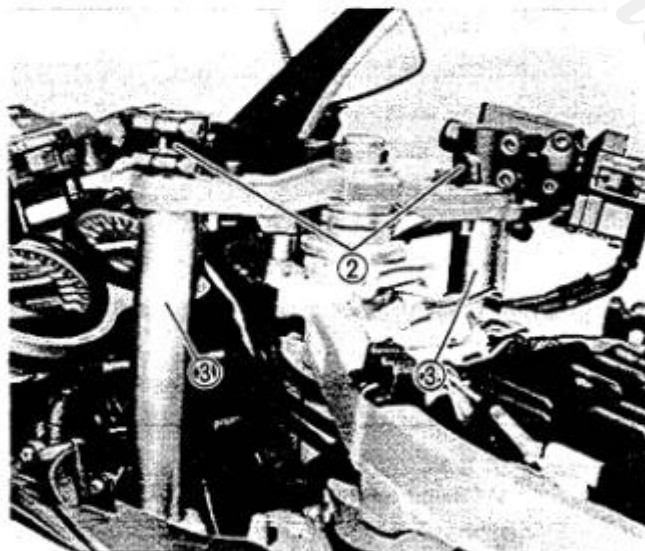

6. Tighten:
 - Pinch bolt (Steering crown)
 - Pinch bolts (Underbracket)
 - Pinch bolt (Handlebar)
 - Handlebar bolt

	<p>Pinch Bolt (Steering Crown): 20 Nm (2.0 m·kg, 14 ft·lb)</p> <p>Pinch Bolt (Underbracket): 23 Nm (2.3 m·kg, 17 ft·lb)</p> <p>Pinch Bolt (Handlebar): 20 Nm (2.0 m·kg, 14 ft·lb)</p> <p>Handlebar: 9 Nm (0.9 m·kg, 6.5 ft·lb)</p>
---	--



7. Install:
- Fork caps
 - Bolt caps
 - Front wheel
 - Front fender
 - Brake calipers
 - Plunger case
 - Speedometer cable

WARNING:

Be sure inside of plunger case is free from any mineral oils. (i.e. engine or fork oil, etc.) before installing. These oils will deteriorate causing failure of the actuating piston O-ring and result in brake fluid leakage.

CAUTION:

After installing the plunger case, check for oil leakage.

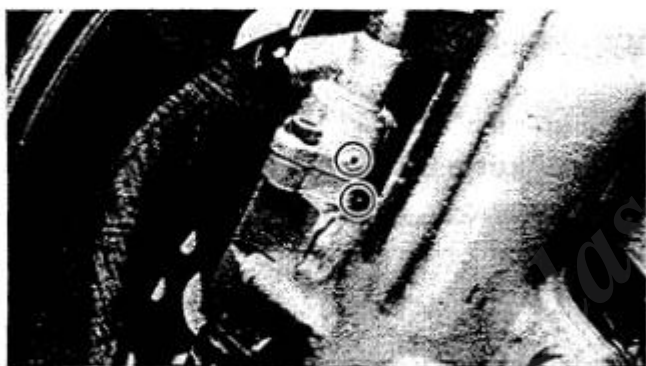

8. Tighten:
- Front axle
 - Axle pinch bolt
 - Front fender
 - Brake caliper
 - Plunger case



Front Axle:
58 Nm (5.8 m·kg, 42 ft·lb)
Front Axle Pinch Bolt:
20 Nm (2.0 m·kg, 14 ft·lb)
Front Fender:
9 Nm (0.9 m·kg, 6.5 ft·lb)
Brake Caliper:
35 Nm (3.5 m·kg, 25 ft·lb)
Plunger Case:
4 Nm (0.4 m·kg, 2.9 ft·lb)

ANTI DIVE SYSTEM

- 1. Plunger
- 2. Brake fluid
- 3. Valve
- 4. Adjuster

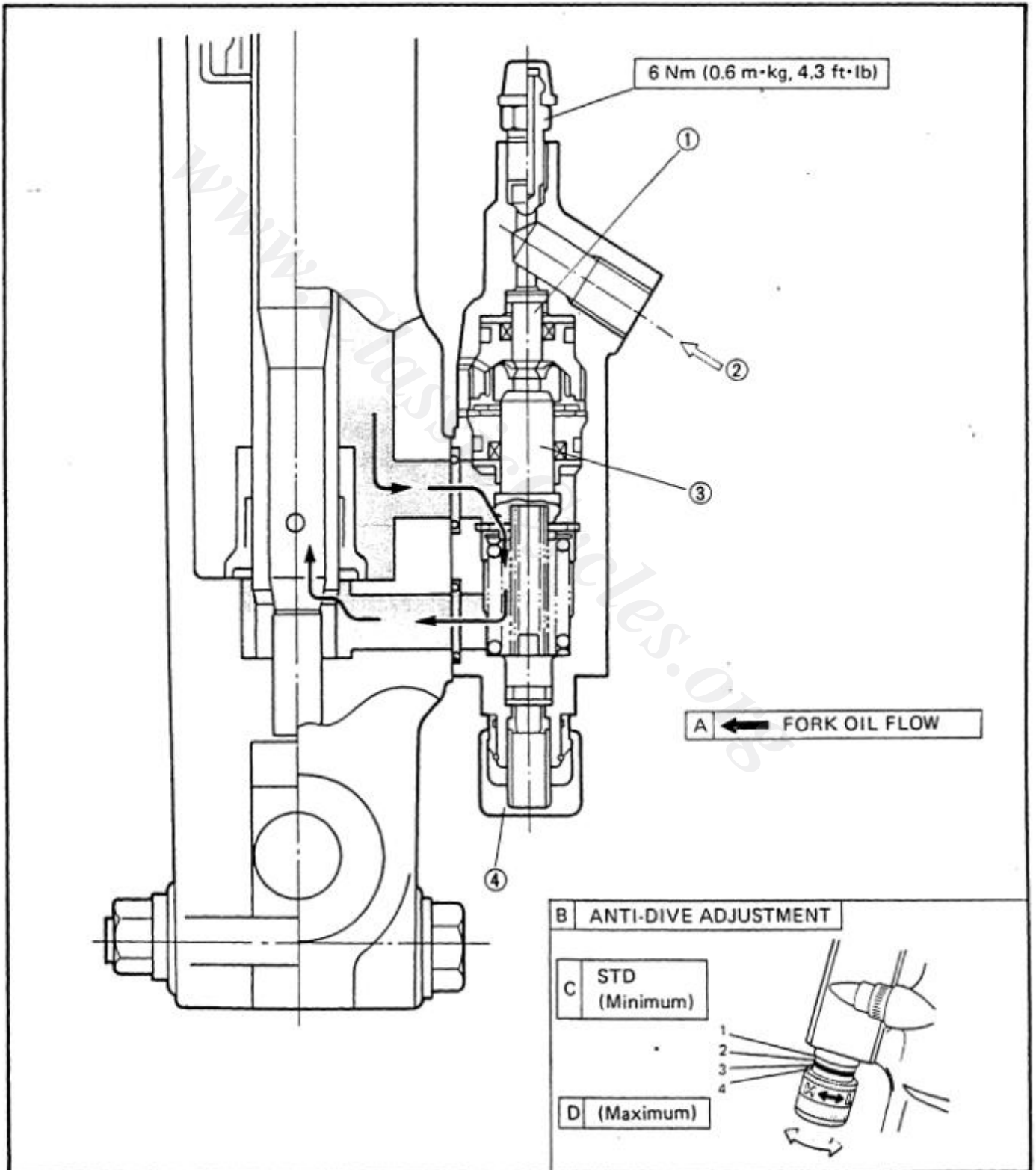

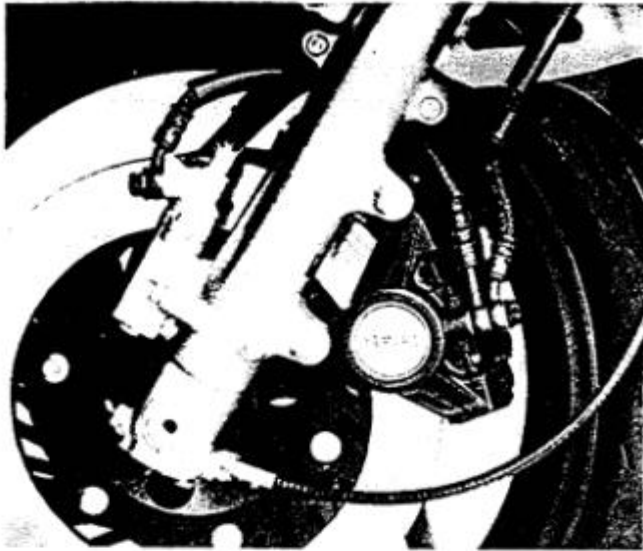

Inspection

Inspection steps:

- Apply the front brake for a few minutes and inspect the pipe joint and vent for brake fluid leakage.
- Inspect the fork for oil leakage.
- Turn the anti-dive adjusting bolt to the maximum position.
- Compress the front forks while applying the front brake. If the front forks compress easily, the anti-dive system may be damaged.

CAUTION:

It is not possible to disassemble the anti-dive valve assembly. Always replace with a new assembly.

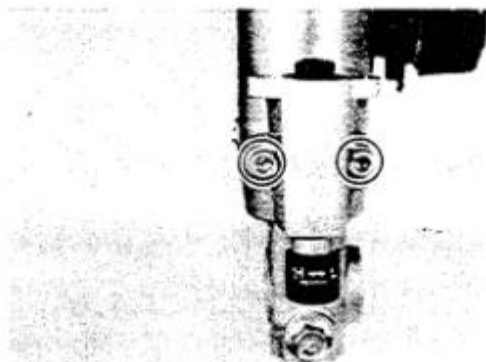
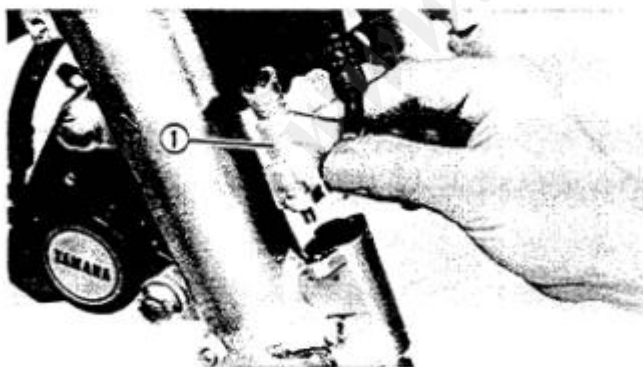

Removal

CAUTION:

Drain the fork oil and brake fluid before removing any components.

1. Remove:
 - Drain screw
Drain fork oil.
 - Brake hose
 - Plunger case ①
2. Remove:
 - Anti-dive valve assembly

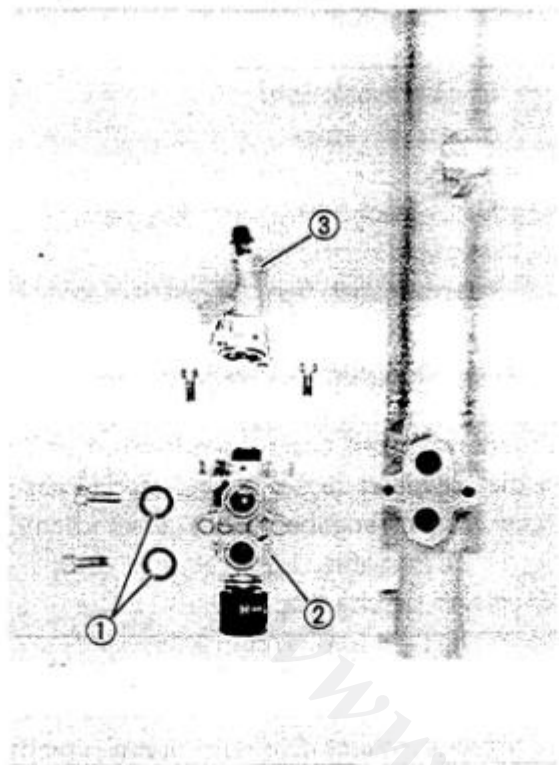

Assembly

Reverse the removal steps.

1. Install:
 - O-rings (New) ①
 - Anti-dive valve assembly ②
 - Plunger case ③
 - Brake hose (With new copper washers)
 - Drain screw (With new gasket)
2. Tighten:
 - Anti-dive valve assembly
 - Plunger case
 - Brake hose
 - Drain screw



Anti-Dive Valve Assembly:

7 Nm (0.7 m·kg, 5 ft·lb)

Plunger Case:

4 Nm (0.4 m·kg, 2.9 ft·lb)

Brake Hose:

26 Nm (2.6 m·kg, 19 ft·lb)

Drain Screw:

2 Nm (0.2 m·kg, 1.4 ft·lb)

YAMAHA BOND No. 1215

(P/N. 90890-85505)

3. Fill:
 - Front fork



(Each):

300 cm³ (10.6 Imp oz, 10.1 US oz)

SAE 5W Type SE Motor Oil or
Equivalent

4. Add brake fluid and bleed the air from the brake system.
5. Inspect:
 - Anti-dive system (after assembling)
 - Oil leaks → Replace O-rings.
 - Still leaks → Replace anti-dive system.



STEERING HEAD

- | | |
|---------------------|---------------------|
| 1. Handlebar | 7. Ring nut (Lower) |
| 2. Nut | 8. Bearing cover |
| 3. Steering crown | 9. Bearing (Upper) |
| 4. Lock washer | 10. Bearing (Lower) |
| 5. Ring nut (Upper) | 11. Steering stem |
| 6. Rubber washer | |

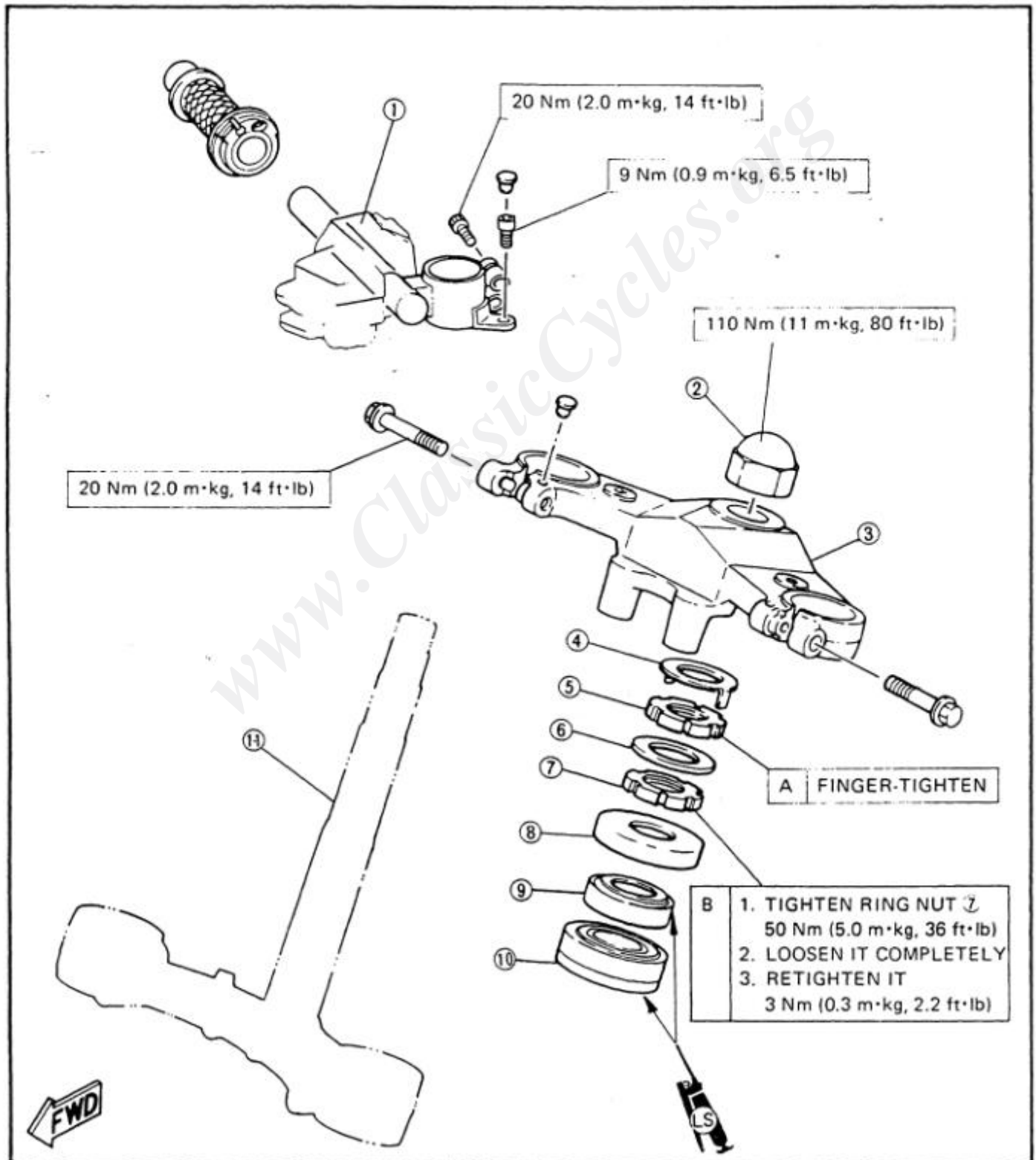

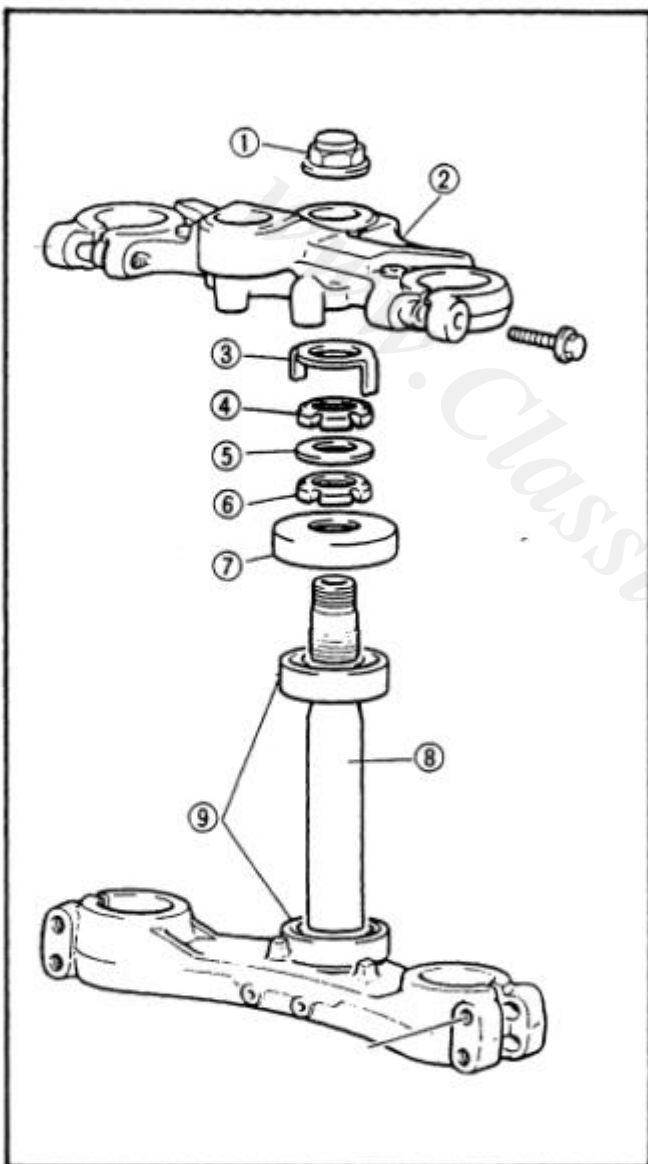
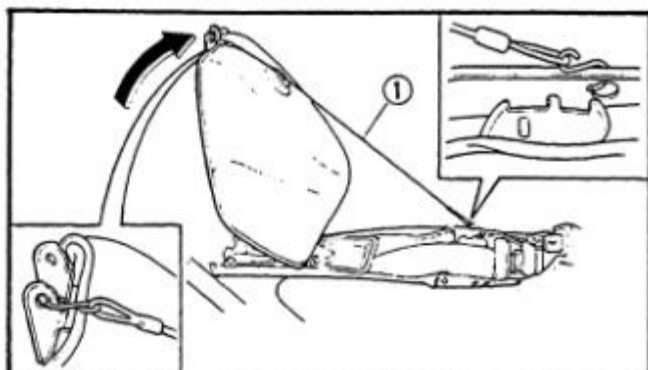

REMOVAL

1. Remove:
 - Bolt (Fuel tank)
2. Pull up the fuel tank. Use the fuel tank holding wire ① as shown.
3. Remove:
 - Front wheel
 - Front forks
 - Handlebars
4. Remove:
 - Steering stem nut ①
 - Steering crown ②
 - Lock washer ③
 - Ring nut (Upper) ④
 - Washer ⑤
 - Ring nut (Lower) ⑥
 - Dust cover ⑦

Remove while holding the steering stem.

 - Steering stem ⑧
 - Bearings ⑨

INSPECTION

1. Wash the bearings in a solvent.
2. Inspect:
 - Bearings
 - Pitting/Damage → Replace.
 - Bearing race
 - Pitting/Damage → Replace.

NOTE: _____
 Always replace bearing and race as a set.

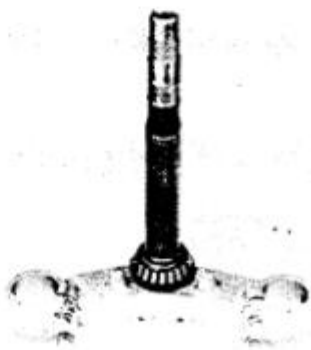



INSTALLATION

1. Install:
 - Bearing races
(into the steering head)
2. Grease the bearings and races.



Wheel Bearing Grease

3. Install:
 - Bearing (Lower)
(onto the steering stem)
 - Steering stem
 - Bearing (Upper)
 - Dust cover
 - Ring nut (Lower)

NOTE:

The tapered side of ring nuts must face downward.

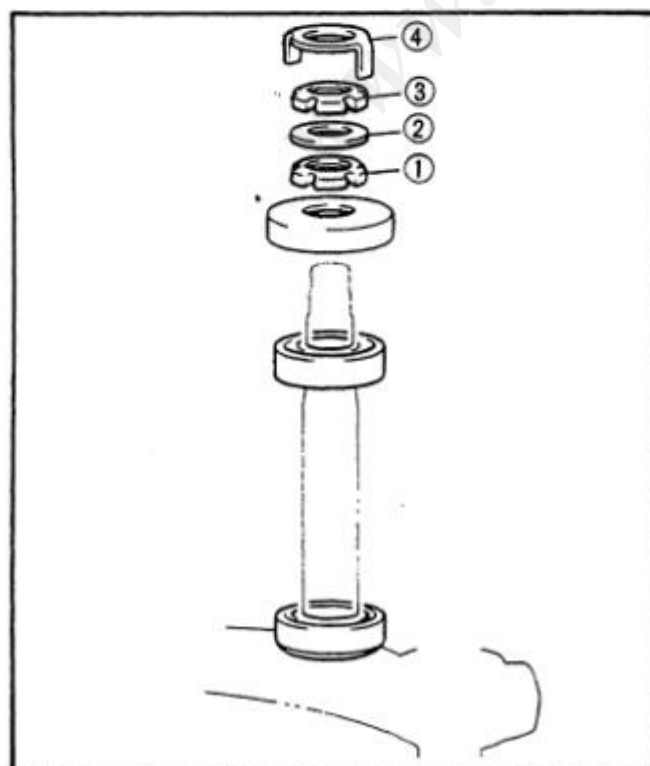

Steering head assembly steps:

- Tighten the ring nut ①.



Ring Nut (Lower):
50 Nm (5.0 m·kg, 36 ft·lb)

- Loosen the ring nut ① completely and retighten the ring nut to specification.



Ring Nut (Lower):
3 Nm (0.3 m·kg, 2.2 ft·lb)

WARNING:

Do not overtighten.

- Install the washer ②.
- Install the ring nut ③ and tighten it by hand and align slots of both ring nuts. If not aligned, hold the ring nut (Lower) and tighten the ring nut (Upper) until they are aligned.
- Install the lock washer ④.

**NOTE:**

Make sure the lock washer tab is placed in the slots.

4. Install:
 - Steering crown
 - Steering stem nut
 - Front fork
5. Tighten:
 - Steering stem nut

**Steering Stem:**

110 Nm (11 m·kg, 80 ft·lb)

6. Install:
 - Brake hose holder
 - Calipers
 - Plunger case
 - Front wheel
 - Front fender
7. Tighten:
 - All bolts and nuts

**Brake Hose Holder:**

10 Nm (1.0 m·kg, 7.2 ft·lb)

Pinch Bolts (Handlebar):

20 Nm (2.0 m·kg, 14 ft·lb)

Handlebar Bolt:

9 Nm (0.9 m·kg, 6.5 ft·lb)

Front Axle:

58 Nm (5.8 m·kg, 42 ft·lb)

Front Axle Pinch Bolt:

20 Nm (2.0 m·kg, 14 ft·lb)

Plunger Case:

4 Nm (0.4 m·kg, 2.9 ft·lb)

Brake Caliper:

35 Nm (3.5 m·kg, 25 ft·lb)

8. Install:
 - Fuel tank



REAR SHOCK ABSORBER

- 1. Tensionbar
- 2. Collar
- 3. Oil seal
- 4. Circlip
- 5. Bearing
- 6. Collar
- 7. Dust seal
- 8. O-ring
- 9. Bushing

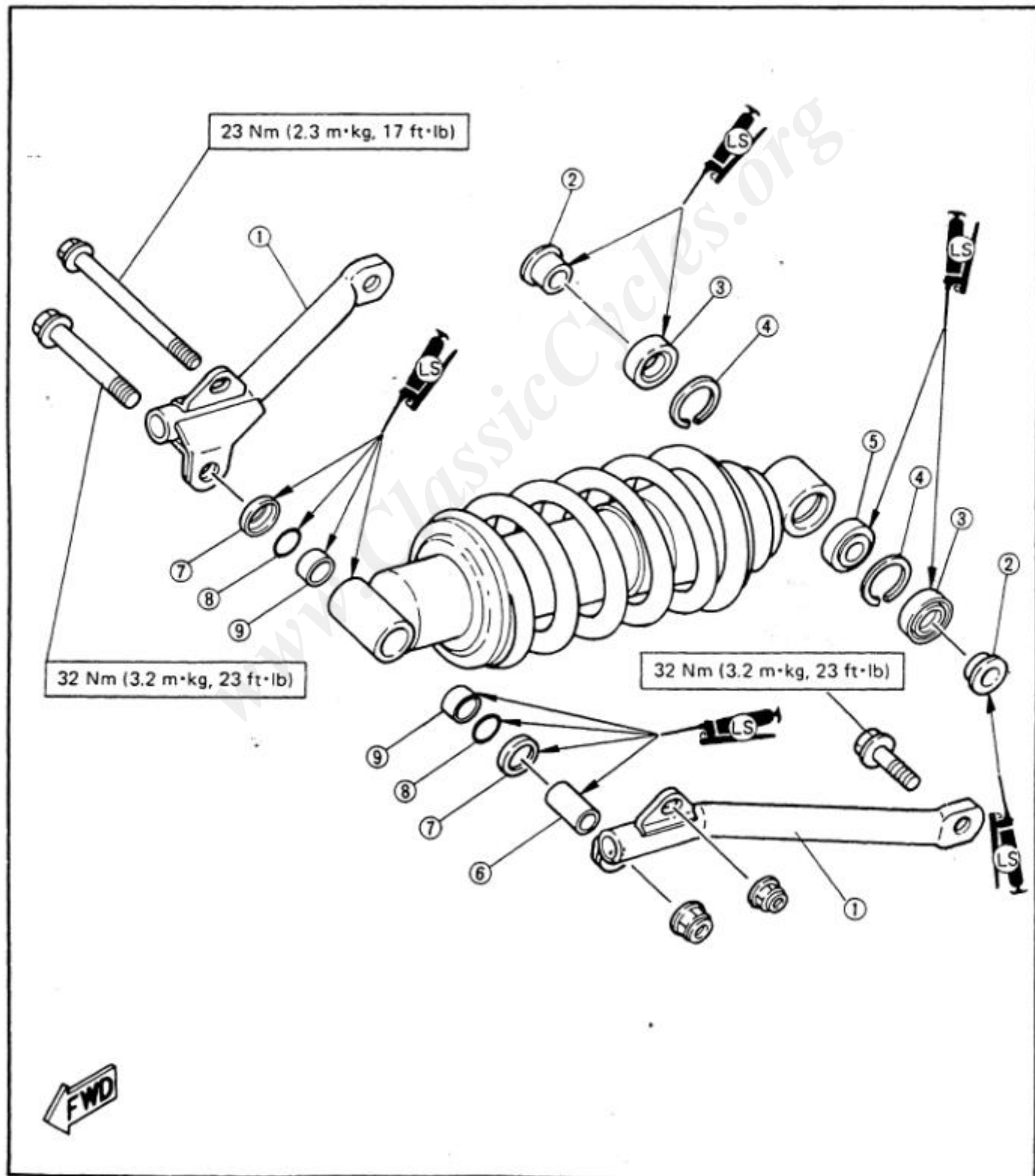

**WARNING:**

This shock absorber contains highly compressed nitrogen gas. Read and understand the following information before handling the shock absorber. The manufacturer cannot be held responsible for property damage or personal injury that may result from improper handling.

1. Do not tamper or attempt to open the cylinder assembly.
2. Do not subject shock absorber to an open flame or other high heat. This may cause the unit to explode due to excessive gas pressure.
3. Do not deform or damage the cylinder in any way. Cylinder damage will result in poor damping performance.

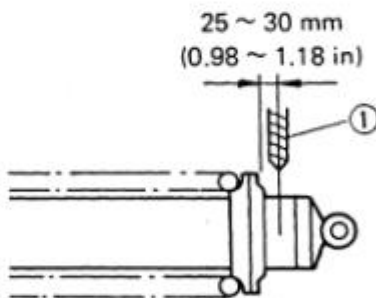
**Shock absorber disposal steps:**

Gas pressure must be released before disposing of shock absorber. To do so, drill ① a 2 ~ 3 mm (0.08 ~ 0.12 in) hole through the cylinder wall at a point 25 ~ 30 mm (0.98 ~ 1.18 in) under the spring seat.

CAUTION:

Wear eye protection to prevent eye damage from escaping gas and/or metal chips.

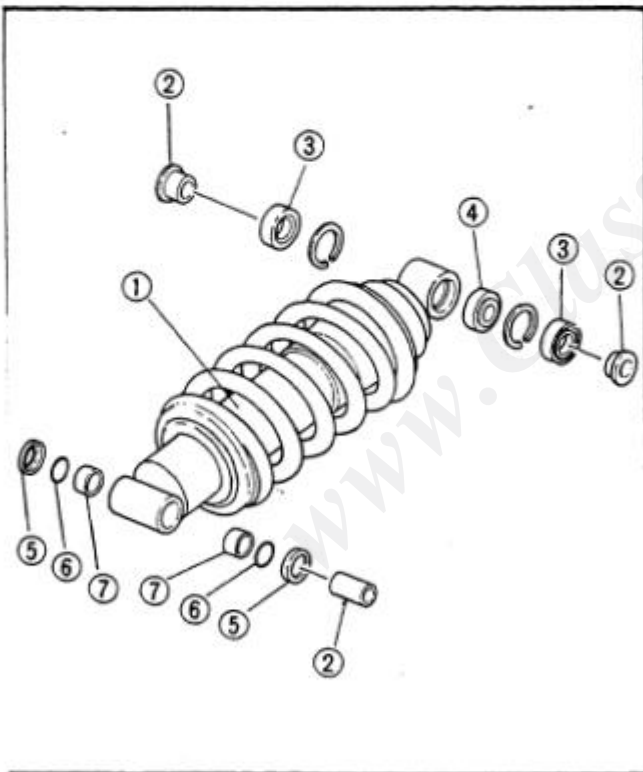
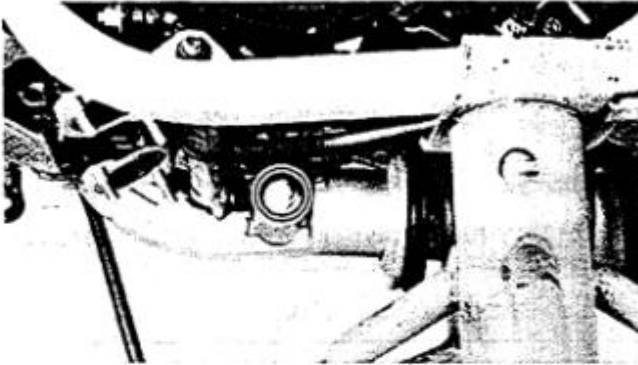
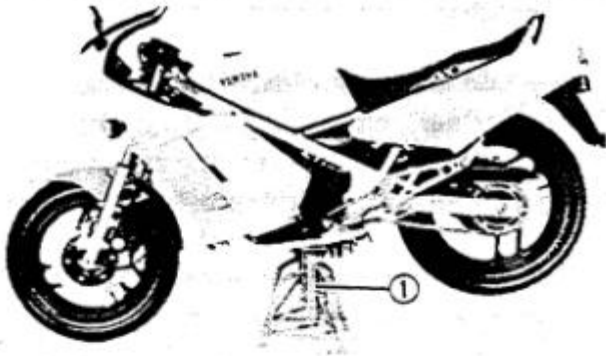

REMOVAL

1. Remove:
 - Lower cowling
 - Mufflers (Lower cylinders)
2. Place the motorcycle on a block or other suitable stand ① under the frame.
3. Remove:
 - Pivot shaft (Front)
 - Pivot shaft (Rear)
 - Shock absorber

INSPECTION

1. Inspect:
 - Shock absorber ①
Oil leaks/Gas leaks/Damage → Replace.

NOTE:

It is not possible to disassemble the shock absorber. Always replace with a new shock absorber.

- Collars ②
Wear/Damage → Replace.
- Oil seals ③
Wear/Damage → Replace.
- Bearing ④
Pitting/Damage → Replace.
- Dust seals ⑤
Wear/Damage → Replace.
- O-rings ⑥
Wear/Damage → Replace.
- Bushings ⑦
Wear/Damage → Replace.



INSTALLATION

- Grease the bearing, bushings, oil seals, dust seals, pivotshafts, collars, and O-rings.

	Lightweight Lithium-soap Base Grease
--	---

- Install:
 - Shock absorber
- Tighten:
 - Pivot shaft (Front)
 - Pivot shaft (Rear)

	Pivot Shaft (Front): 32 Nm (3.2 m·kg, 23 ft·lb)
	Pivot Shaft (Rear): 32 Nm (3.2 m·kg, 23 ft·lb)

- Adjust:
 - Spring preload
 - Damper

A SPRING PRELOAD ADJUSTMENT:

Adjusting position	HARD				STD
	5	4	3	2	1

B DAMPING ADJUSTMENT:

Adjusting position	HARD	STD	SOFT
	4	3	2

- Install:
 - Mufflers
 - Lower cowling

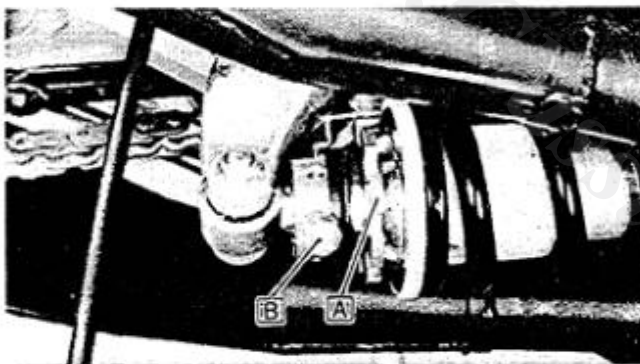
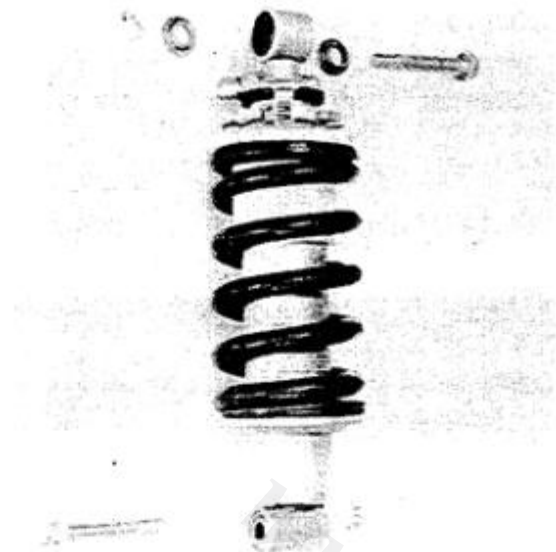

SWINGARM AND RELAY ARM

- | | |
|--------------------|-----------------|
| 1. Thrust cover | 9. Oil seal |
| 2. Thrust washer | 10. Relay arm 1 |
| 3. Collar | 11. Relay arm 2 |
| 4. Bearing | 12. Bushing |
| 5. Swing arm | 13. Cap nut |
| 6. Pivot shaft | |
| 7. Grease nipple | |
| 8. Chain protector | |

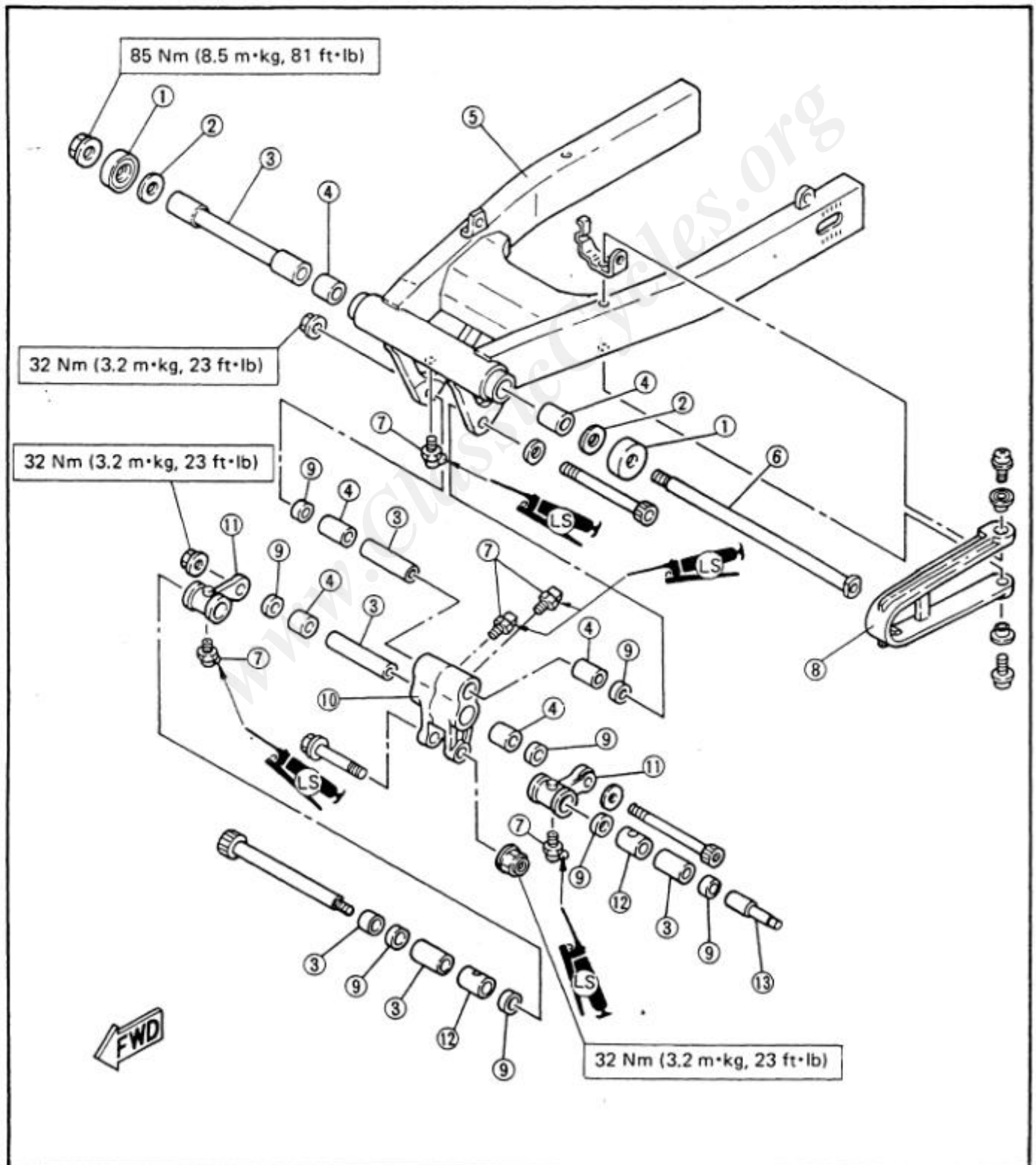

SWINGARM AND RELAY ARMS INSTALLATION (1)

- 1. Swingarm
- 2. Relay arm 1
- 3. Relay arm 2
- 4. Tension bar
- 5. Rear shock absorber
- 6. Grease nipple
- 7. Oil seal
- 8. Bearing
- 9. Pivot shaft
- 10. Collar

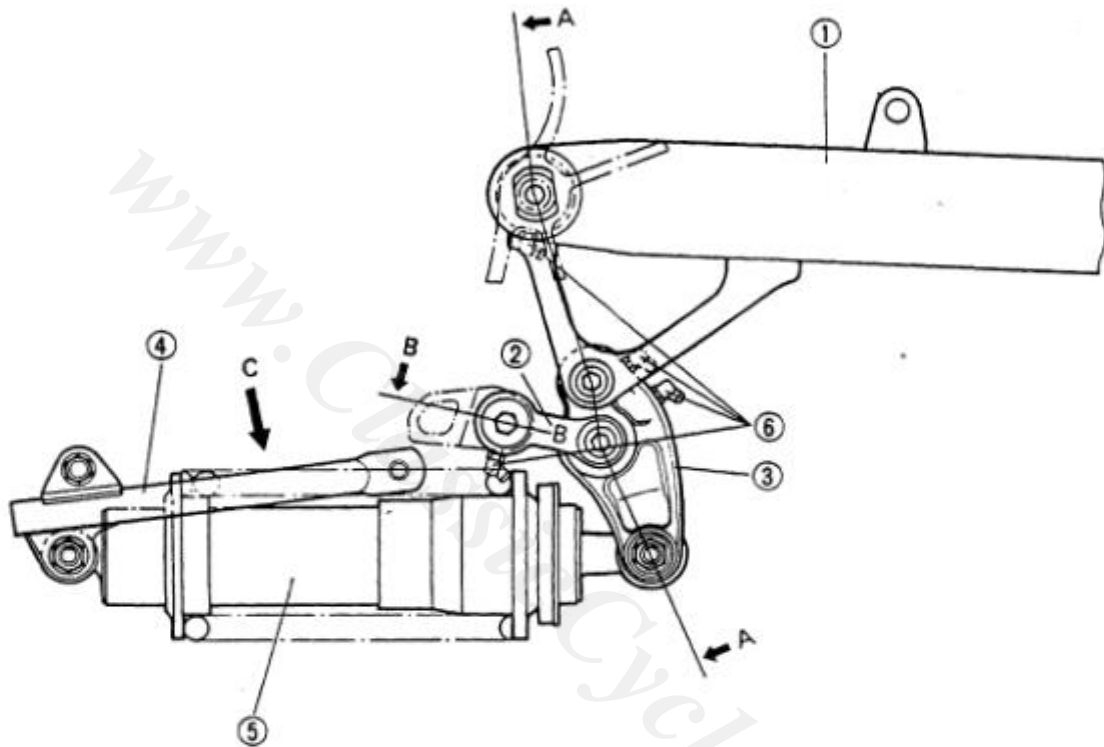

A A - A SECTION

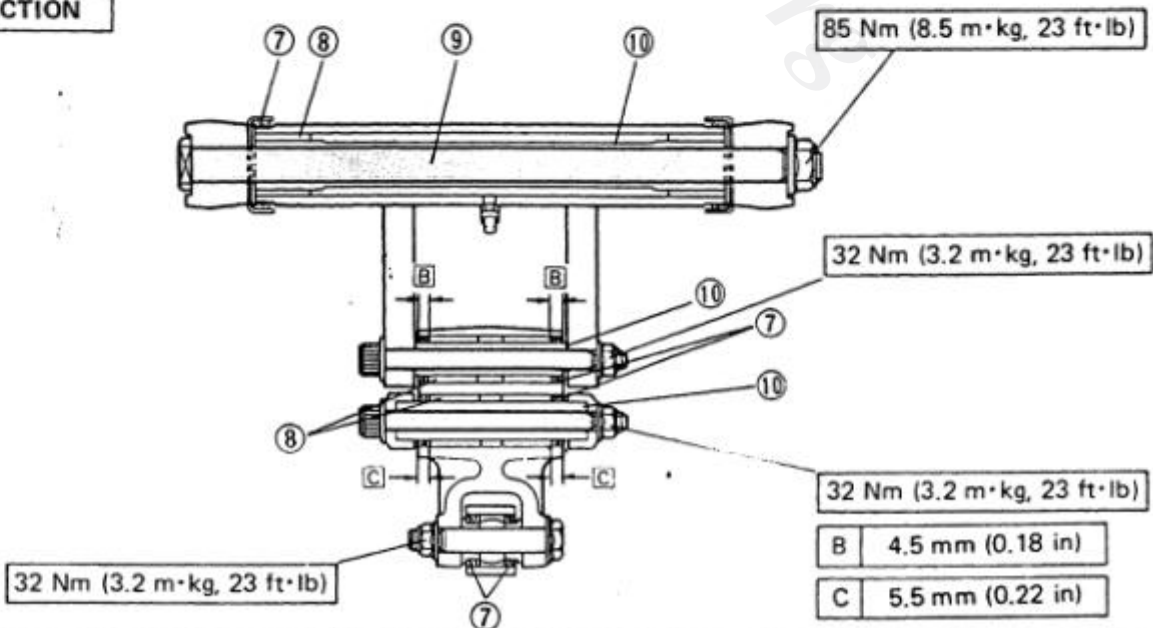

SWINGARM AND RELAY ARMS INSTALLATION (2)

- 1. Cap nut
- 2. Oil seal
- 3. Frame
- 4. Collar
- 5. Busing

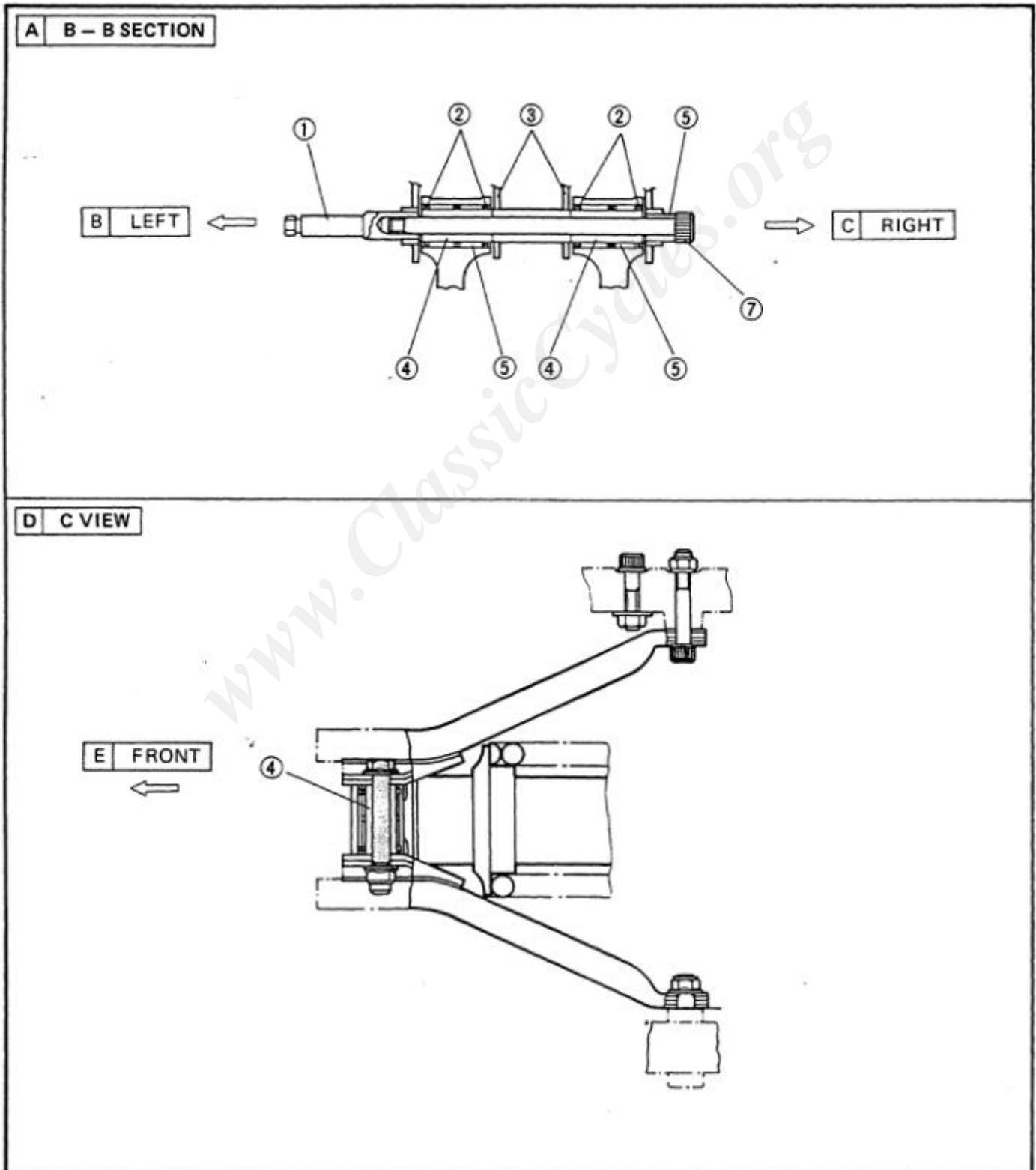

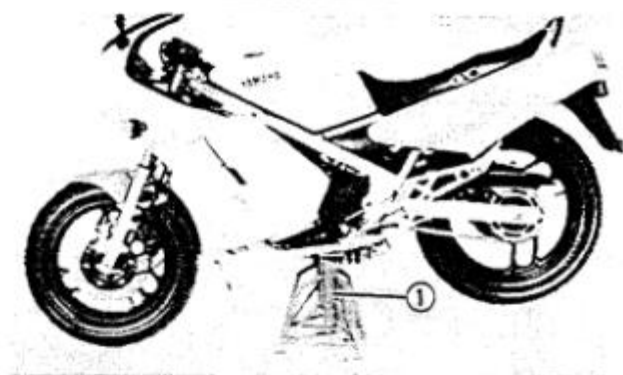

SWINGARM FREE PLAY INSPECTION

1. Remove:
 - Lower cowling
 - Mufflers (Lower cylinders)
2. Place the motorcycle on a block or other suitable stand ① under the frame.
3. Remove:
 - Rear wheel
4. Remove:
 - Pivot shaft (Shock absorber rear)
 - Bolt (Swingarm – Relay arm 2)
5. Inspect:
 - Free play
Try to move the swingarm from side to side.
Noticeable free play → Replace bearings, thrust washers, collar, and thrust covers.
6. Check:
 - Swingarm movement
Move the swingarm up and down.
Unsmooth operation → Apply grease/
Replace bearings and collar.

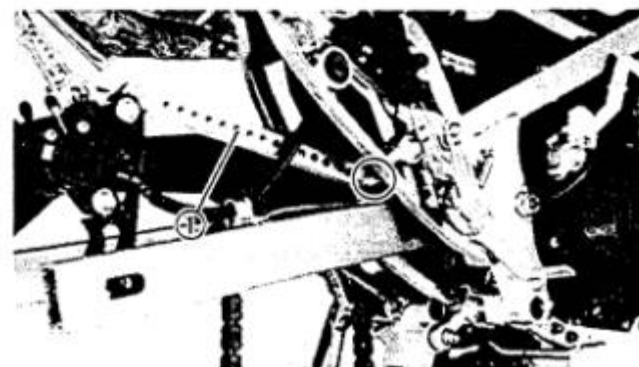
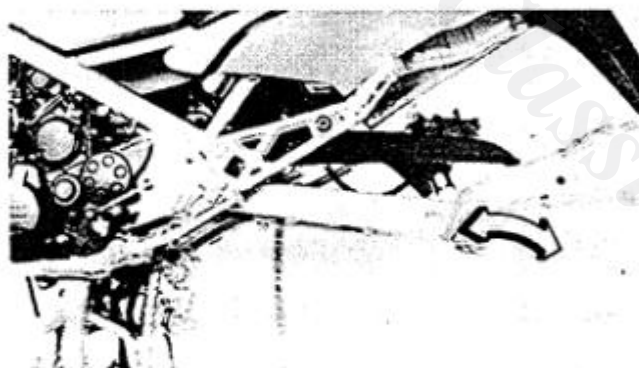
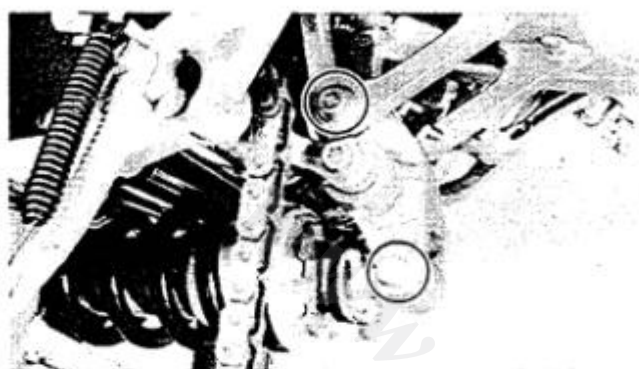

REMOVAL

1. Remove:
 - Bolt (Tension bar)

① Tension bar

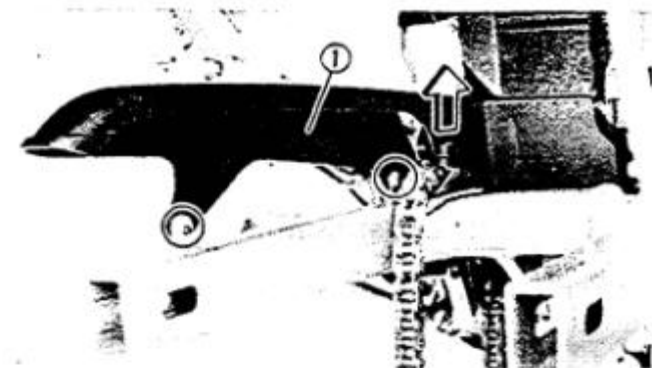

2. Remove:
- Chain guard ①

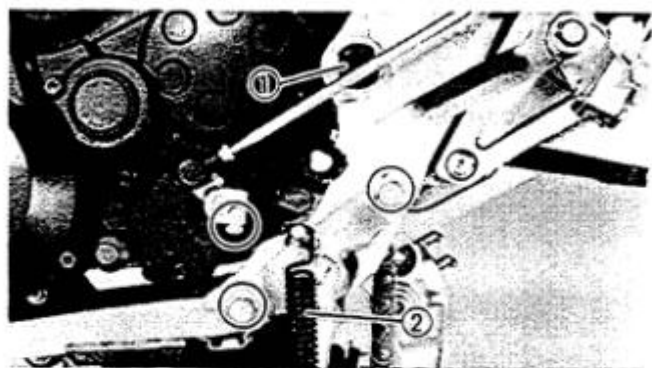

3. Remove:
- Bolt (Shift arm)
 - Pivot shaft (Swingarm) ①
 - Swingarm
 - Sidestand ②

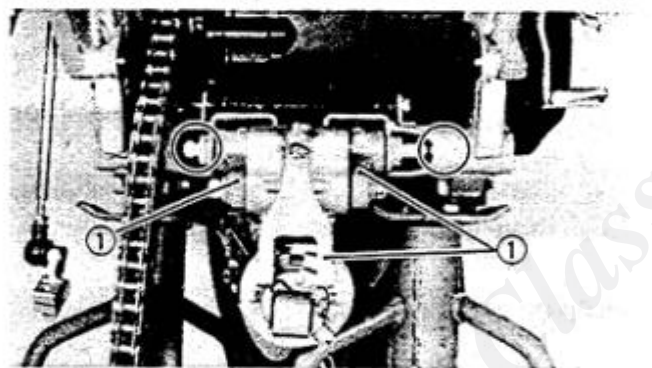

4. Remove:
- Bolt (Relay arm 1 – Frame)
 - Relay arms ①

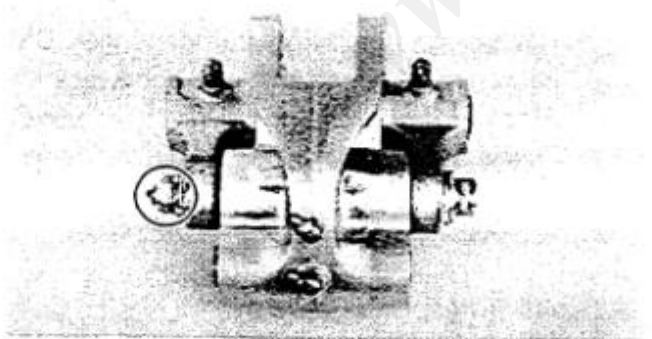

5. Remove:
- Bolt (Relay arm 1 – Relay arm 2)

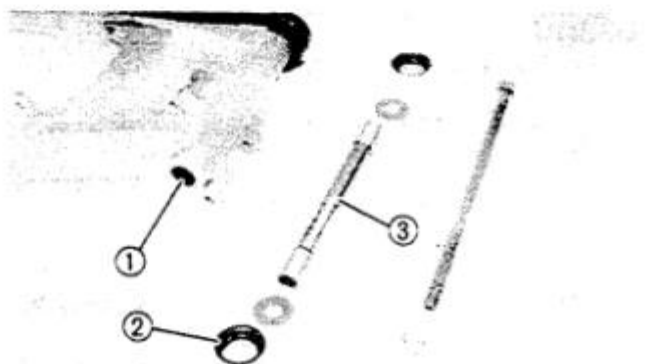

INSPECTION

1. Inspect:
- Bearings ①
Pitting/Damage → Replace.
 - Thrust covers ②
Wear/Damage → Replace.
 - Collar ③
Wear/Damage → Replace.

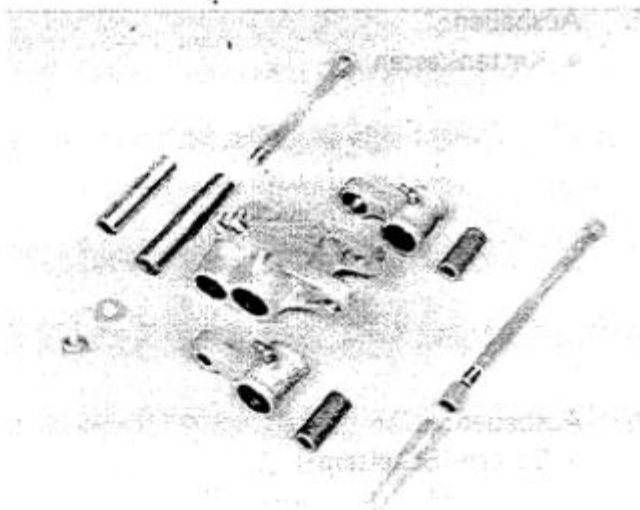

2. Inspect:
 - Oil seals
Wear/Damage → Replace.
 - Bushings
Wear/Damage → Replace.
 - Collars
Wear/Damage → Replace.

INSTALLATION

1. Grease the busings, bearings, collars, oil seals thrust covers, and bolts.



Lightweight Lithium-Soap
Base Grease

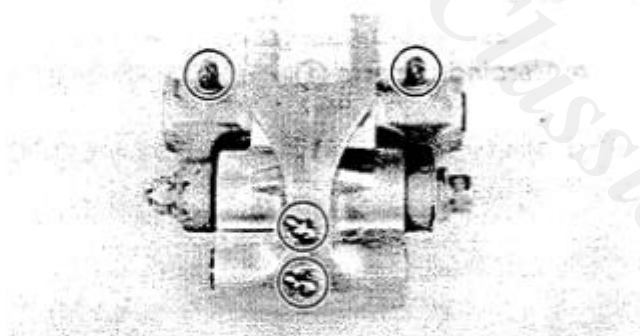

2. Assemble:
 - Relay arms

NOTE:

The relay arm 1 and relay arm 2 should be assembled so that the grease nipples on each arm are pointed upward.

3. Finger tighten the bolt.
4. Install
 - Relay arms
5. Tighten:
 - Bolt



Frame – Relay Arm 1:
32 Nm (3.2 m·kg, 23 ft·lb)

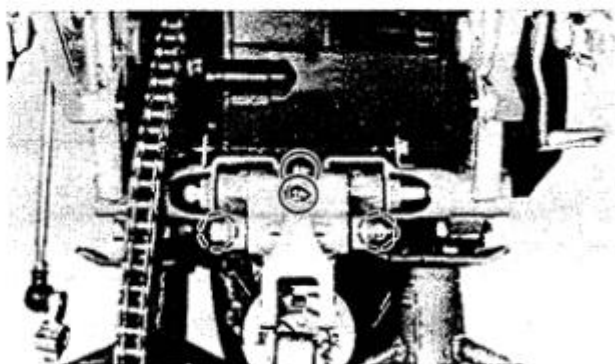

6. Install:
 - Swingarm
 - Shock absorber
 - Sidestand
 - Shift arm

7. Tighten:
- Bolts

	Pivot Shaft (Swingarm):
	85 Nm (8.5 m•kg, 81 ft•lb)
	Swingarm-Relay Arm 2:
	32 Nm (3.2 m•kg, 23 ft•lb)
	Shock Absorber-Relay arm 2:
	32 Nm (3.2 m•kg, 23 ft•lb)
Sidestand:	
32 Nm (3.2 m•kg, 23 ft•lb)	
Shift Arm:	
10 Nm (1.0 m•kg, 7.2 ft•lb)	

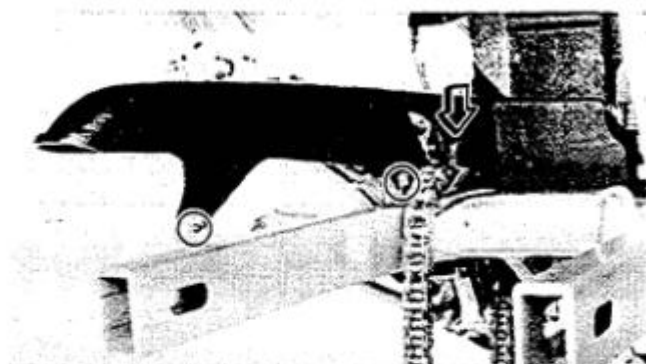

8. Install:
- Chain guard

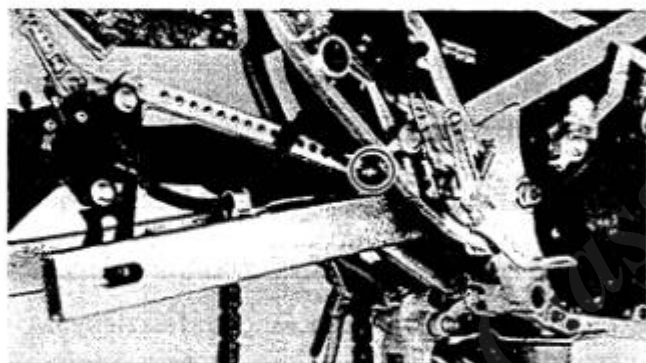

9. Install:
- Tension bar
 - Rear wheel
10. Tighten:
- Bolts
 - Nut

	Tension Bar:
	30 Nm (3.0 m•kg, 22 ft•lb)
	Rear Axle:
	105 Nm (10.5 m•kg, 75 ft•lb)
Locknut (Rear axle):	
60 Nm (6.0 m•kg, 43 ft•lb)	

11. Adjust:
- Drive chain

	Drive Chain Slack ①:
	15 ~ 20 mm (0.6 ~ 0.8 in)

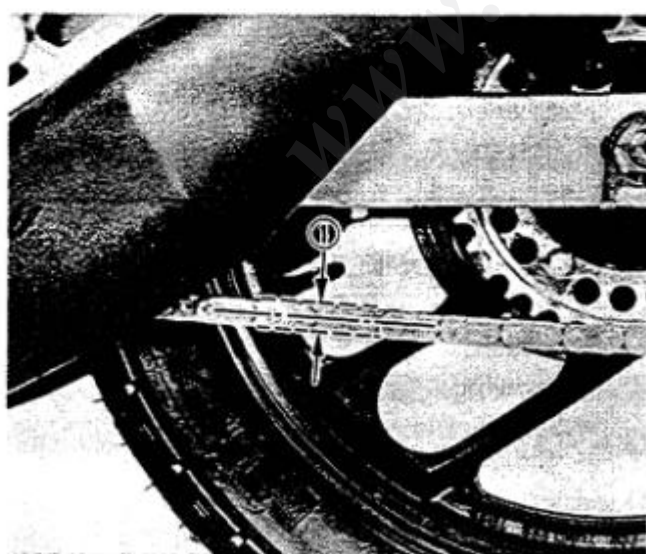

12. Install:
- Mufflers
 - Lower cowling

CABLES AND FITTINGS**CABLE MAINTENANCE****NOTE:**

See "MAINTENANCE AND LUBRICATION" interval charts. Cable maintenance is primarily concerned with preventing deterioration and providing proper lubrication to allow the cable to move freely within its housing. Cable removal is straightforward and uncomplicated. Removal is not discussed within this section.

WARNING:

Cable routing is very important. For details of cable routing, see the "CABLE ROUTING" at the end of this manual. Improperly routed or adjusted cables may make the motorcycle unsafe for operation.

- ① Throttle cable
- ② Clutch cable
- ③ Oil pump cable
- ④ Circlip

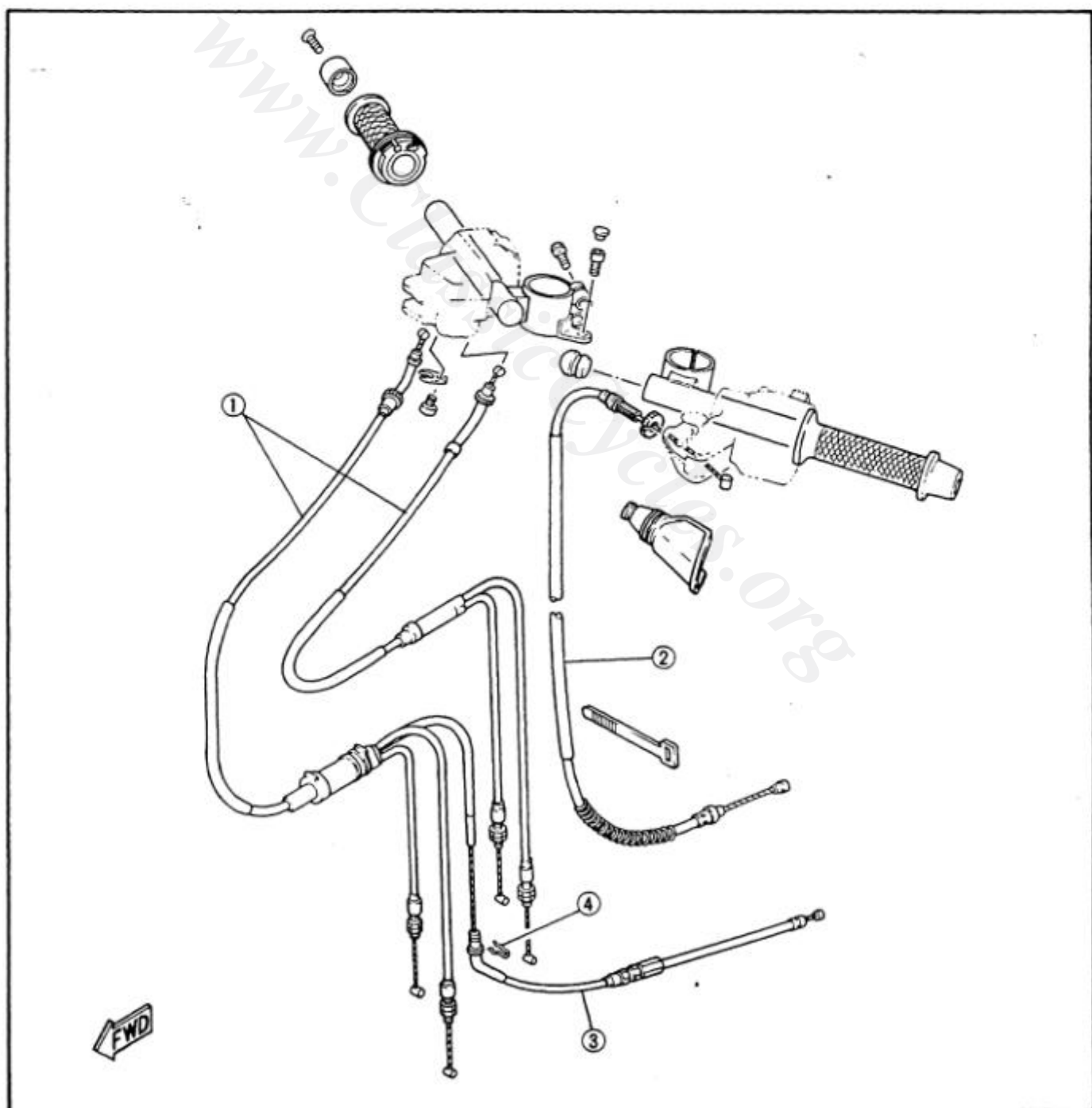

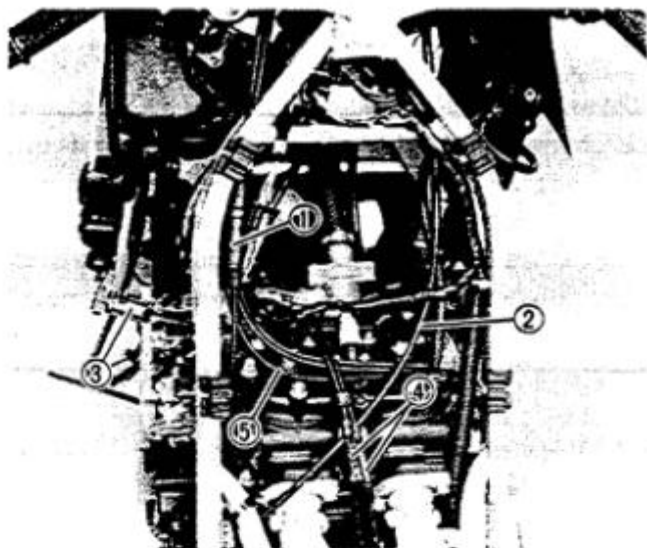

1. Remove:
 - Throttle cables ①
 - Clutch cable ②
 - Choke cable ③
 - YPVS cables ④
 - Speedometer cable
 - Oil pump cables ⑤
2. Check:
 - Cable free movement
Obstruction → Inspect for wear/Damage.
Kinking/Frayed strands/Damage → Replace.
3. Lubricate the cable.

Cable lubrication steps:

- Hold the cable in a vertical position.
- Apply lubricant to the uppermost end of the cable.
- Maintain its vertical position until the oil flows to the bottom.
- Allow excess oil to drain, then reinstall the cable.

NOTE:

Choice of lubricant depends upon conditions and preferences. The use of a semi-drying chain and cable lubricant will perform adequately under most conditions.



Recommended Lubricant:
SAE 10W30 Motor Oil

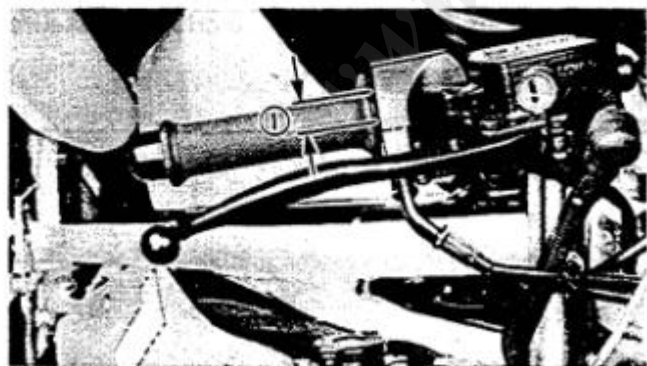

4. Install:
 - Cables
Reverse the removal procedure.

NOTE:

Tighten the housing screws evenly to maintain an even gap between the two housing halves.



Throttle Cable Free Play ①:
3 ~ 7 mm (0.12 ~ 0.28 in)

CHAPTER 7. ELECTRICAL

RD500LC CIRCUIT DIAGRAM.....	7-1
ELECTRICAL COMPONENTS.....	7-3
IGNITION AND STARTING SYSTEM.....	7-7
TROUBLESHOOTING.....	7-9
TROUBLESHOOTING CHART.....	7-11
IGNITION COIL.....	7-15
PICKUP AND SOURCE COILS RESISTANCE.....	7-17
SPARK PLUG.....	7-19
CHARGING SYSTEM.....	7-21
TROUBLESHOOTING CHART.....	7-23
GENERATOR VOLTAGE INSPECTION.....	7-25
STATOR COIL INSPECTION.....	7-25
RECTIFIER INSPECTION.....	7-27
BATTERY.....	7-29
LIGHTING SYSTEM.....	7-35
LIGHTING TESTS AND CHECKS.....	7-37
TROUBLESHOOTING CHART.....	7-37
HEADLIGHT ADJUSTMENT.....	7-41
SIGNAL SYSTEM.....	7-43
TROUBLESHOOTING CHART.....	7-45
SELF-CANCELLING FLASHER SYSTEM (Except for Germany).....	7-51
OIL LEVEL SWITCH.....	7-51
SWITCHES.....	7-53
COOLING SYSTEM.....	7-57
TROUBLESHOOTING CHART.....	7-59
THERMO UNIT AND THERMOMETER.....	7-63
ELECTRIC FAN AND THERMO SWITCH.....	7-65
YPVS SYSTEM.....	7-69
TROUBLESHOOTING CHART.....	7-71
YPVS CONTROL UNIT.....	7-75
YPVS SERVOMOTOR.....	7-75



ELECTRICAL

RD500LC CIRCUIT DIAGRAM

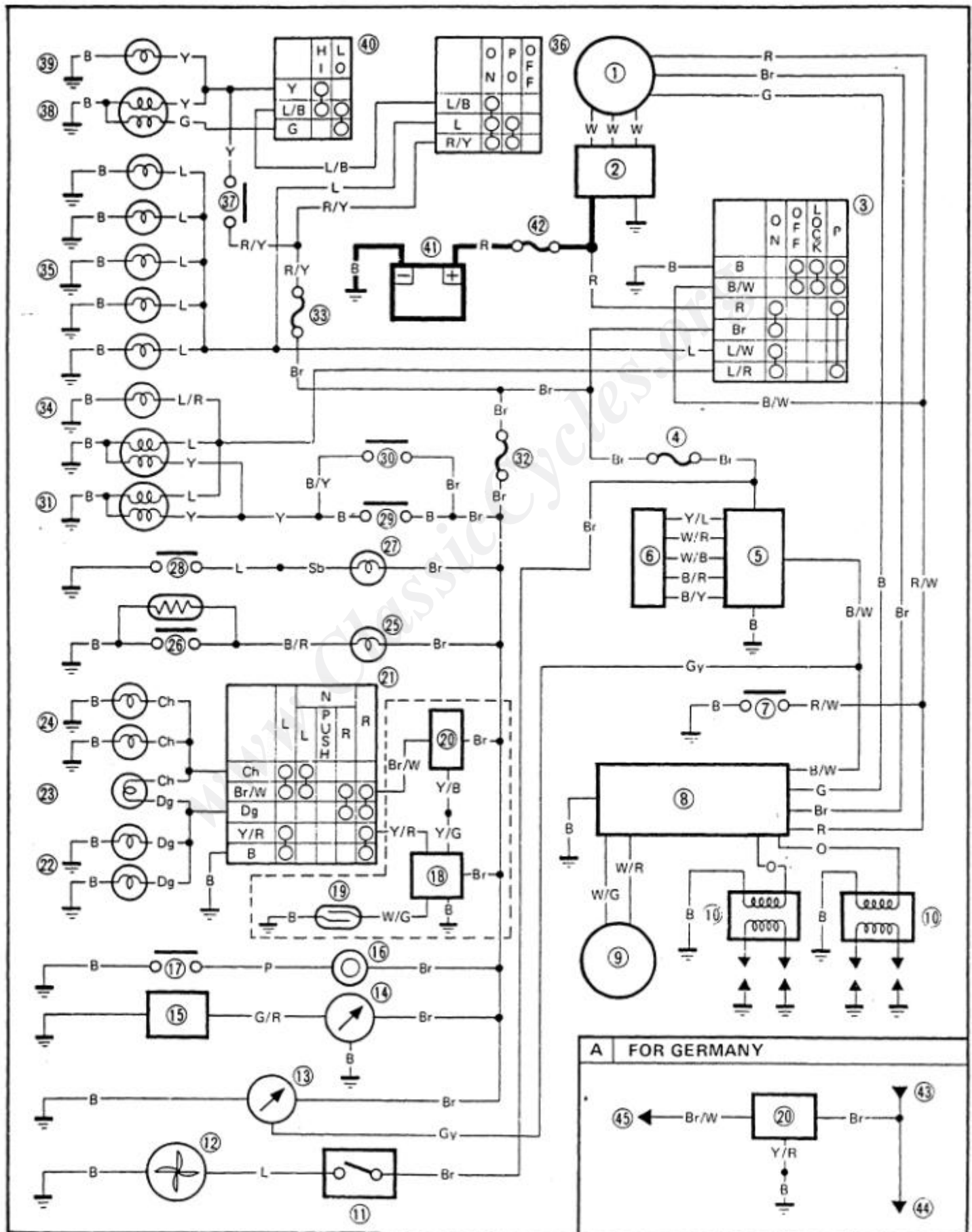



PARTIE ELECTRIQUE

ELEKTRISCHE ANLAGE

SCHEMA DU CIRCUIT DE LA RD500LC RD500LC SCHALTPLAN

1. AC magneto
2. Rectifier/Regulator
3. Main switch
4. Fuse "YPVS" (10A)
5. YPVS control unit
6. YPVS servomotor unit
7. "ENGINE STOP" switch
8. CDI unit
9. Pickup coil
10. Ignition coil
11. Thermo switch
12. Fan motor
13. Tachometer
14. Temperature gauge
15. Thermo unit
16. Horn
17. "HORN" switch
18. Flasher cancelling unit (Except for Germany)
19. Reed switch (Except for Germany)
20. Flasher relay
21. "TURN" signal switch
22. Flasher light (Right)
23. "TURN" indicator light
24. Flasher light (Left)
25. "OIL" indicator light
26. Oil level switch
27. "NEUTRAL" indicator light
28. Neutral switch
29. Rear brake switch
30. Front brake switch
31. Tail/Brake light
32. Fuse "SIGNAL" (10A)
33. Fuse "HEAD" (15A)
34. Auxiliary light
35. Meter light
36. "LIGHTS" switch
37. "PASS" switch
38. Headlight
39. "HIGH BEAM" indicator light
40. "LIGHTS" (Dimmer) switch
41. Battery
42. Fuse "MAIN" (20A)
43. From fuse "SIGNAL" (10A)
44. To horn
45. To "TURN" signal switch
- Ⓐ FOR GERMANY

1. Alternateur
2. Redresseur/Régulateur
3. Contacteur à clé
4. Fusible "YPVS" (10A)
5. Bloc de commande du YPVS
6. Bloc servomoteur du YPVS
7. Commutateur "ENGINE STOP"
8. Bloc CDI
9. Bobine d'excitation
10. Bobine d'allumage
11. Thermocontact
12. Moteur de ventilateur
13. Compte-tours
14. Indicateur de température
15. Sonde thermique
16. Avertisseur
17. Commutateur d'avertisseur "HORN"
18. Unité d'arrêt des clignotants (Excepté Allemagne)
19. Commutateur à lame (Excepté Allemagne)
20. Relais des clignotants
21. Commutateur des clignoteurs "TURN"
22. Clignotant (Droit)
23. Indicateur de clignotant "TURN"
24. Clignotant (Gauche)
25. Indicateur de niveau d'huile "OIL"
26. Contacteur de niveau d'huile
27. Indicateur de point mort "NEUTRAL"
28. Contacteur de point mort
29. Contacteur de frein arrière
30. Contacteur de frein avant
31. Feu arrière/stop
32. Fusible de signalisation "SIGNAL" (10A)
33. Fusible de phare "HEAD" (15A)
34. Témoin auxiliaire
35. Eclairage de compteur
36. Commutateur d'éclairage "LIGHTS"
37. Commutateur d'appel de phare "PASS"
38. Phare
39. Indicateur de feu de route "HIGH BEAM"
40. Commutateur de feu de route/feu de croisement "LIGHTS"
41. Batterie
42. Fusible principal (20A)
43. Du fusible "SIGNAL"
44. Vers l'avertisseur
45. Vers le commutateur des clignoteurs "TURN"
- Ⓐ ALLEMAGNE

1. Wechselstrom-Magnetzünder
2. Gleichrichter/Spannung sregler
3. Hauptschalter
4. Sicherung "YPVS" (10A)
5. YPVS-Steuereinheit
6. YPVS-Servomotoreinheit
7. Motorstoppschalter "ENGINE STOP"
8. CDI-Zündeinheit
9. Suchspule
10. Zündspule
11. Thermostatschalter
12. Lüftermotor
13. Drehzahlmesser
14. Temperaturanzeige
15. Temperaturegeber
16. Hupe
17. Signalhornknopf "HORN"
18. Blinkleuchten-Abschaltautomatik (Ausgenommen für Deutschland)
19. Zungenschalter (Ausgenommen für Detuschland)
20. Blinkerrelais
21. Blinklichtschalter "TURN"
22. Blinklicht (Rechts)
23. Blinklicht-Kontrollampe "TURN"
24. Blinklicht (Links)
25. Ölstand-Kontrollampe "OIL"
26. Ölstandscharter
27. Leerlauf-Kontrollampe "NEUTRAL"
28. Leerlaufschalter
29. Hinterrad-Bremslichtschalter
30. Vorderrad-Bremslichtschalter
31. Schluß/Bremsleuchte
32. Sicherung "SIGNAL" (10A)
33. Sicherung "HEAD" (15A)
34. Nummernschildbeleuchtung
35. Instrumenten-Kontrollampe
36. Lichtschalter "LIGHTS"
37. Lichtkupenschalter "PASS"
38. Scheinwerfer
39. Fernlicht-Kontrollampe "HIGH BEAM"
40. Lichtschalter "LIGHTS" (Dimmer)
41. Batterie
42. Sicherung "MAIN" (20A)
43. Von der Sicherung "SIGNAL" (10A)
44. Zum Signalhorn
45. Zum Blinkleuchtenschalter
- Ⓐ FÜR DEUTSCHLAND

R	Red Rouge Rot	G	Green Vert Grün	Dg	Dark Green Vert Foncé Dunkelgrün	W/R	White/Red Blanc/Rouge Weiß/Rot	Y/R	Yellow/Red Jaune/Rouge Gelb/Rot	L/R	Blue/Red Bleu/Rouge Blau/Rot
W	White Blanc Weiß	Y	Yellow Jaune Gelb	Ch	Chocolate Chocolat Schokoladenfarbe	W/G	White/Green Blanc/Vert Weiß/Grün	Y/L	Yellow/Blue Jaune/Bleu Gelb/Blau	L/B	Blue/Black Bleu/Noir Blau/Schwarz
B	Black Noir Schwarz	P	Pink Rose Rosa	Sb	Sky Blue Bleu Ciel Himmelblau	W/B	White/Black Blanc/Noir Weiß/Schwarz	Y/G	Yellow/Green Jaune/Vert Gelb/Grün	B/W	Black/White Noir/Blanc Schwarz/Weiß
L	Blue Bleu Blau	O	Orange Orange Orange	G/R	Green/Red Vert/Rouge Grün/Rot	R/W	Red/White Rouge/Blanc Rot/Weiß	Y/B	Yellow/Black Jaune/Noir Gelb/Schwarz	B/R	Black/Red Noir/Rouge Schwarz/Rot
Br	Brown Brun Braun	Gy	Gray Gris Grau	Br/W	Brown/White Brun/Blanc Braun/Weiß	R/Y	Red/Yellow Rouge/Jaune Rot/Gelb	L/W	Blue/White Bleu/Blanc Blau/Weiß	B/Y	Black/Yellow Noir/Jaune Schwarz/Gelb



ELECTRICAL COMPONENTS (1)

1. Fuse box
(HEADLIGHT: 15A, YPVS: 10A, SIGNAL: 10A)
2. Main fuse
3. Battery
4. Ignition coil (Lower cylinder)
5. Rectifier/Regulator
6. CDI unit
7. Ignition coil (Upper cylinder)

IGNITION COIL:
Primary winding resistance: 0.67Ω ± 20% at (68°F)
Secondary winding resistance: 12 kΩ ± 20% at (68°F)
BATTERY:
Capacity: 12V 5.5AH
Specific gravity: 1.280

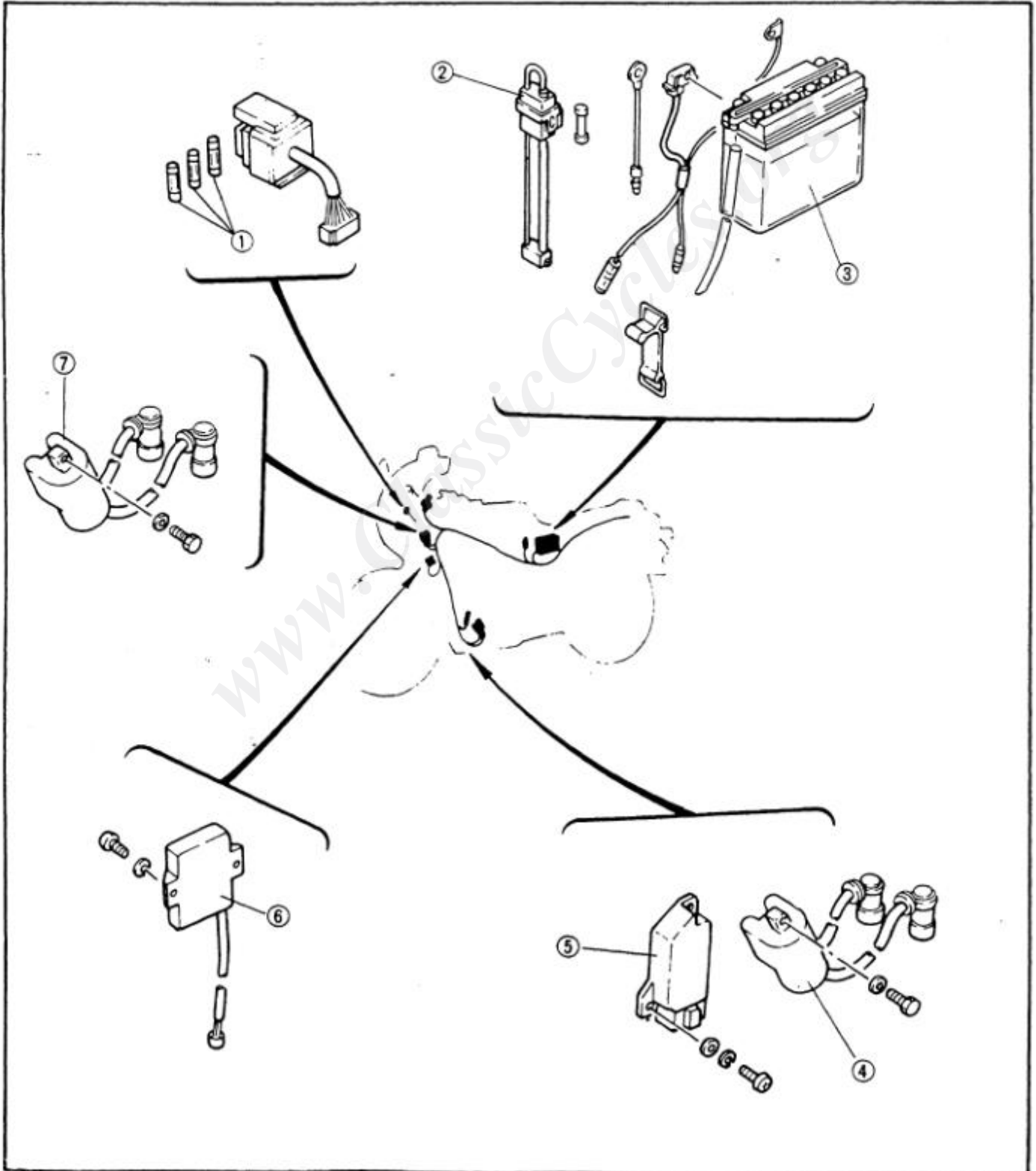



ELECTRICAL COMPONENTS (2)

1. Flasher relay
2. Oil level switch
3. Servomotor
4. Brake switch (Rear)
5. Thermo unit
6. Neutral switch
7. Gasket
8. Thermo unit
9. YPVS control unit
10. Flasher cancelling unit (Except for Germany)

PICKUP COIL RESISTANCE/COLOR:
112Ω ± 20% at 20°C (68°F) (White/Green – White/Red)
SOURCE COIL RESISTANCE:
127Ω ± 20% at 20°C (68°F) (Green – Brown)
18.8Ω ± 20% at 20°C (68°F) (Brown – Red)

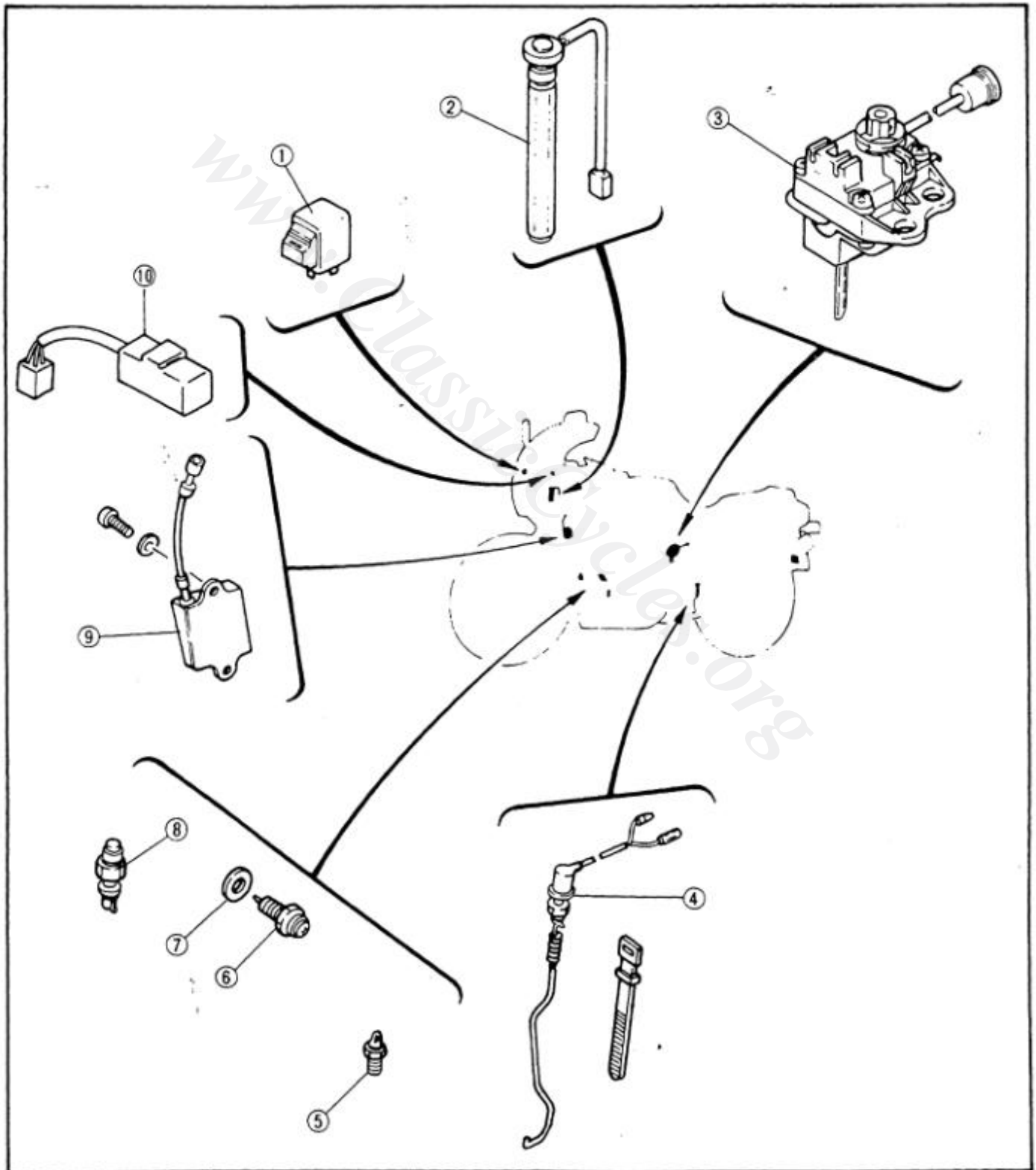



IGNITION AND STARTING SYSTEM

Below circuit diagram shows ignition and starting system.

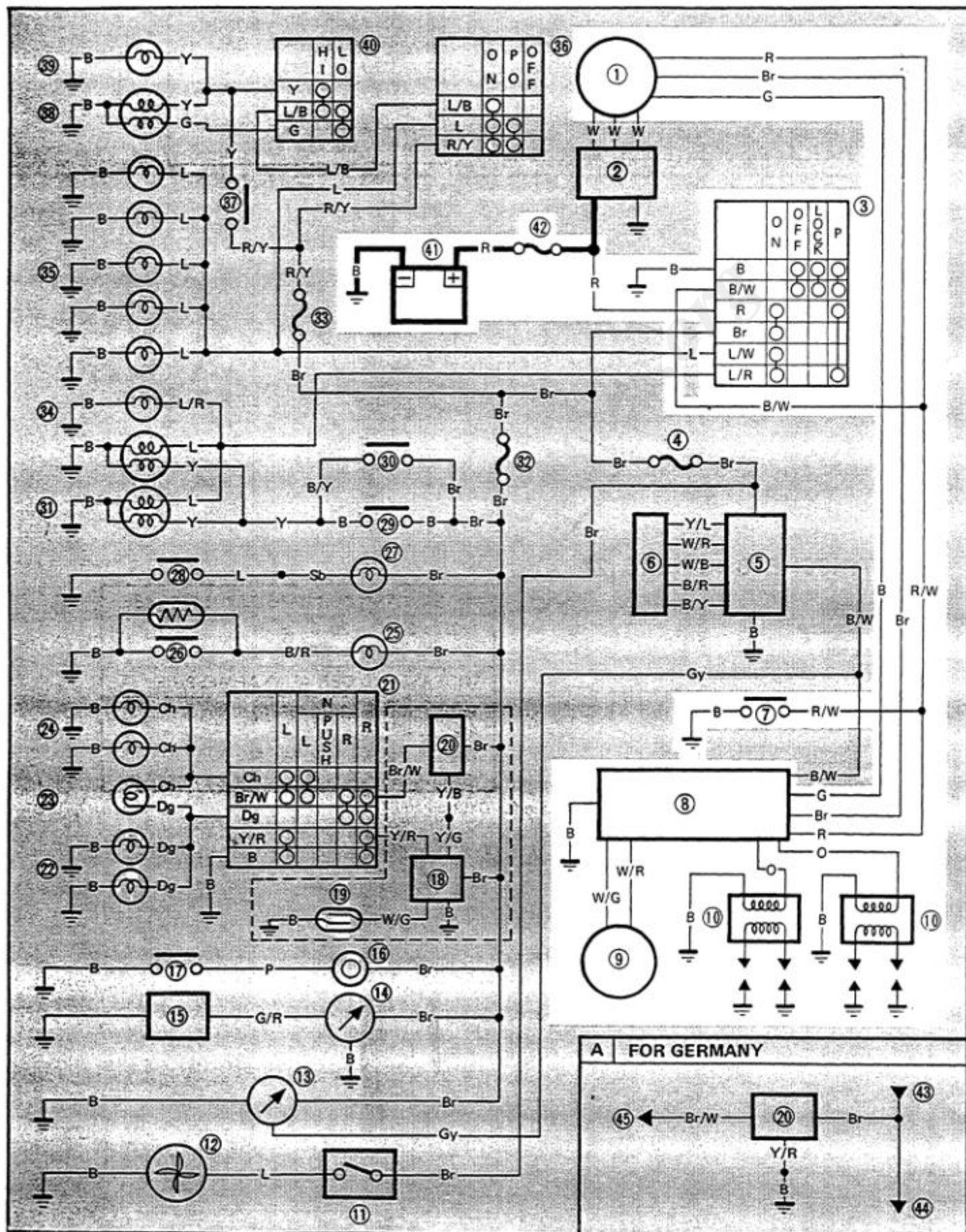

- | | |
|-------------------------|-----------------------|
| 1. AC magneto | 9. Pickup coil |
| 3. Main switch | 10. Ignition coil |
| 7. "ENGINE STOP" switch | 41. Battery |
| 8. CDI unit | 42. Fuse "MAIN" (20A) |

SYSTEME D'ALLUMAGE ET DE DEMARRAGE

Le schéma ci-dessous montre le circuit d'allumage et de démarrage.

- | | |
|------------------------------|------------------------------------|
| 1. Alternateur | 9. Bobine d'excitation |
| 3. Contacteur à clé | 10. Bobine d'allumage |
| 7. Commutateur "ENGINE STOP" | 41. Batterie |
| 8. Bloc CDI | 42. Fusible principal "MAIN" (20A) |

ZÜNDANLAGE UND ANLASSER

Der nachfolgende Schaltplan zeigt das Zündanlagen- und Anlassersystem.

- | | |
|-------------------------------------|----------------------------|
| 1. Wechselstrom-Magnetzünder | 9. Suchspule |
| 3. Hauptschalter | 10. Zündspule |
| 7. Motorstoppschalter "ENGINE STOP" | 41. Batterie |
| 8. CDI-Zündeinheit | 42. Sicherung "MAIN" (20A) |

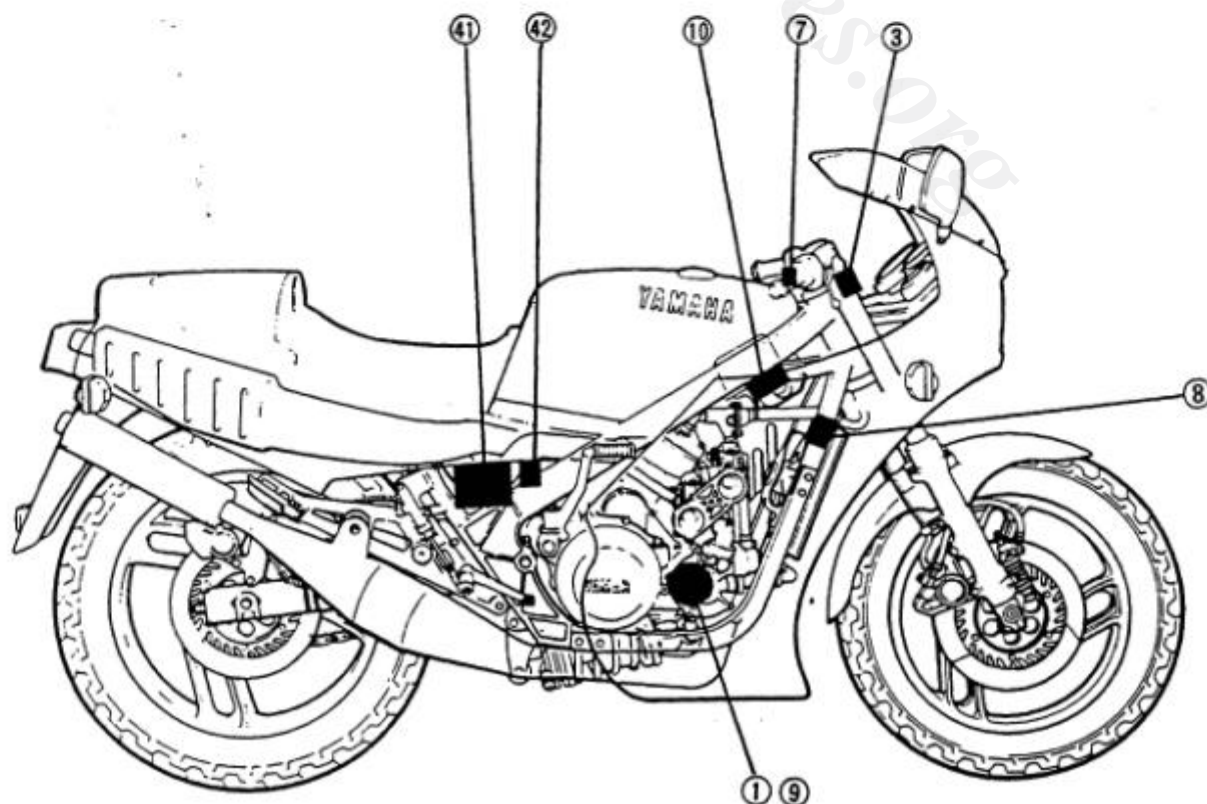



TROUBLESHOOTING

The entire ignition system can be checked for misfire and weak spark by using the Electro Tester (90890-03021).

1. Warm up the engine so that all of the electrical components are at operating temperature.

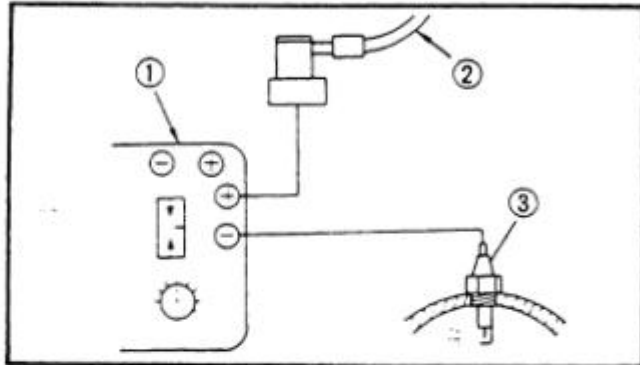

2. Connect:
 - Electro Tester (90890-03021) ①
3. Start the engine, and increase the spark gap until misfire occurs. (Test at various r/min between idle and red line.)

- ② Spark plug wire
- ③ Spark plug

CAUTION:

Do not run the engine in neutral above 6,000 r/min for more than 1 or 2 seconds.



Minimum Spark Gap: 6 mm (0.24 in)

Faulty ignition system operation (at the minimum spark gap or smaller)
 → Follow the troubleshooting chart until the source of the problem is located.



TROUBLESHOOTING CHART (1)

ENGINE DOES NOT START

Remove the fuel tank securing bolt, and pull up the fuel tank. Use the fuel tank holding wire ① to hold the fuel tank.

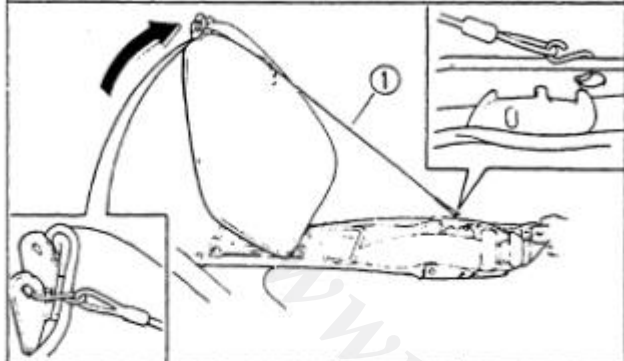

Disconnect the AC magneto ① and pickup coil ② connectors. Measure the pickup ③ and source ④ coils resistance.

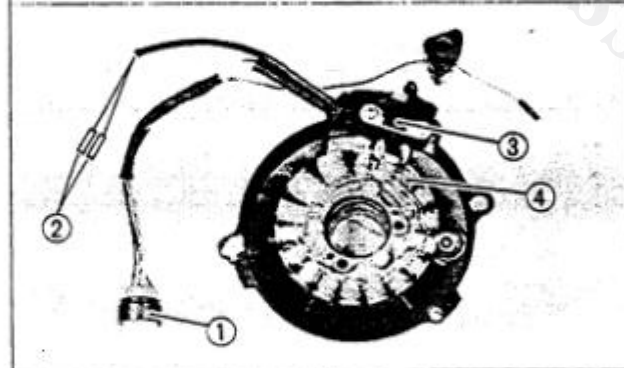

Disconnect the ignition coil leads. Measure the ignition coils ① primary and secondary coils resistance.

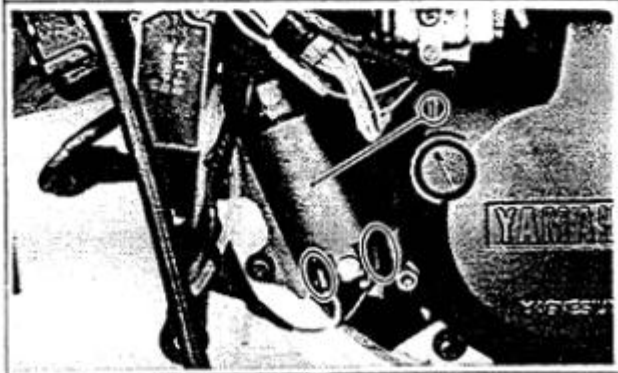

CDI unit is faulty, replace the unit.

Out of specification → Replace the coil(s).

- A Pickup coil:
 $112\Omega \pm 20\%$ at 20°C (68°F)
 (White/Green – White/Red)
- B Source coil:
 $127\Omega \pm 20\%$ at 20°C (68°F)
 (Red – Green)
 $18.8\Omega \pm 20\%$ at 20°C (68°F)
 (Brown – Red)

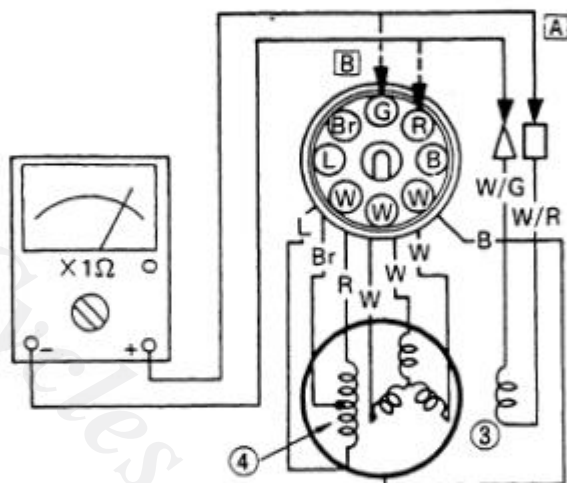

Out of specification → Replace the coil(s).

- A Primary:
 $0.67\Omega \pm 20\%$ at 20°C (68°F)
- B Secondary:
 $12\text{ k}\Omega \pm 20\%$ at 20°C (68°F)

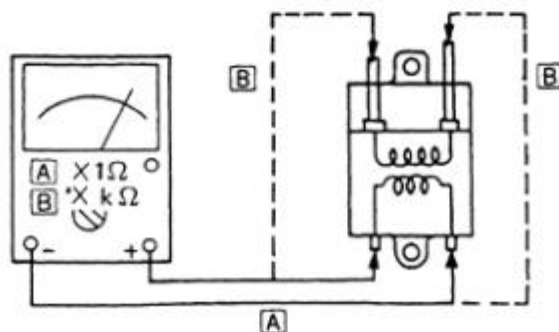



TROUBLESHOOTING CHART (2)

"NEUTRAL" INDICATOR LIGHT DOES NOT COME ON.

Remove the meter assembly and disconnect the indicator light connector ①.

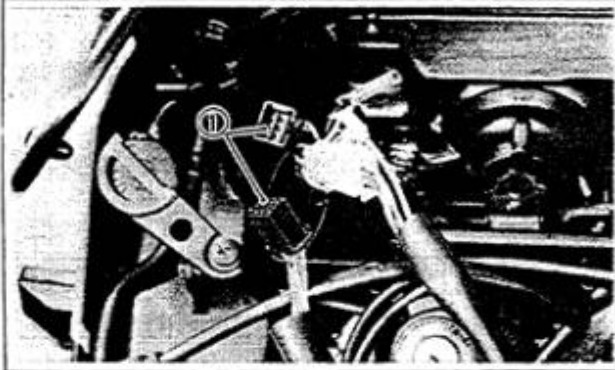

Turn the main switch "ON".

Check the battery voltage (12V) on the Brown lead from the wire harness.

NO

Check for an open or poor connection between the fuse (SIGNAL) and "NEUTRAL" indicator light connector.

YES

Reconnect the indicator light connector. Connect the Sky blue lead ① from the wire harness to "ground" on the frame; use a jumper lead ②.

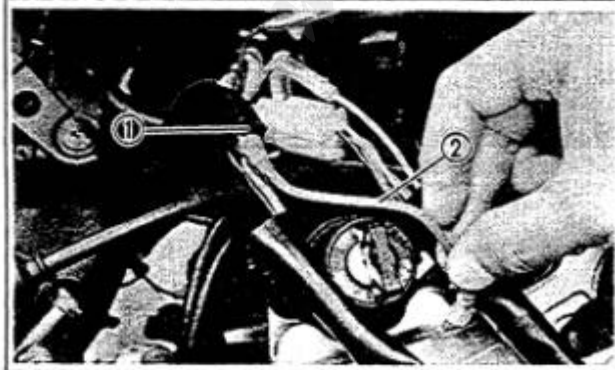

"NEUTRAL" indicator light comes on.

NO

Replace the bulb (12V - 3.4W).

YES

Replace the neutral switch.

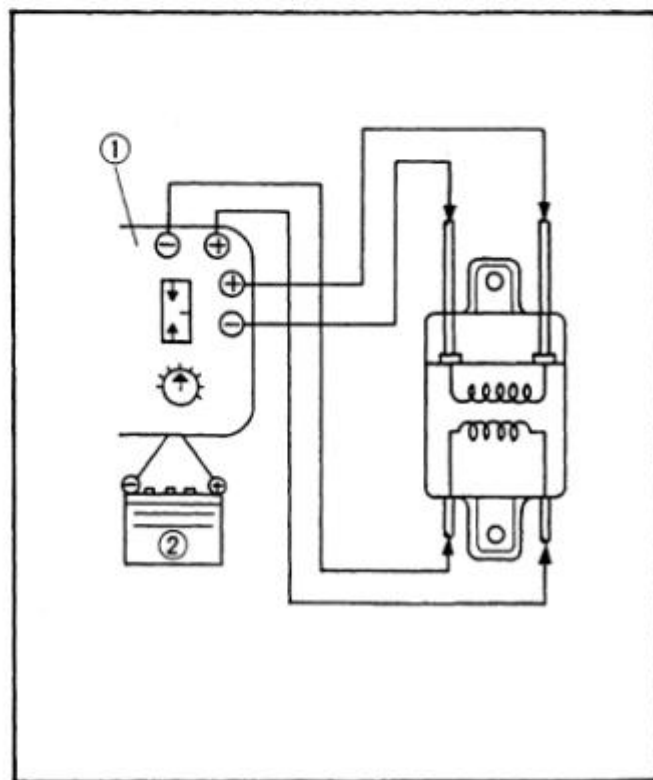
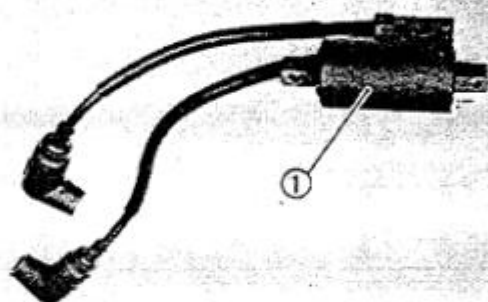
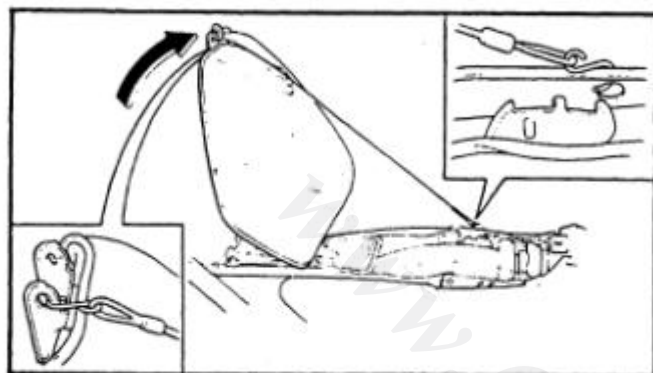
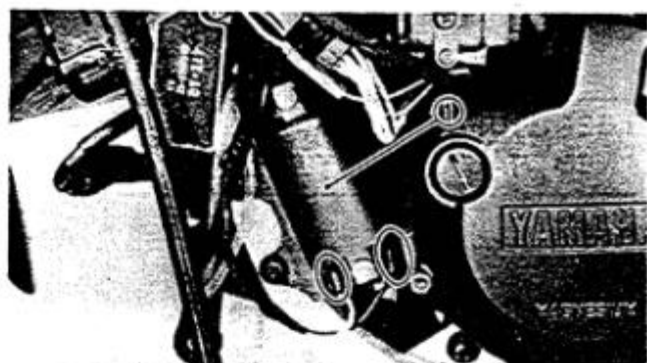

IGNITION COIL

Removal

1. Remove:
 - Lower cowling
 - Ignition coil (Lower cylinder) ①
2. Remove:
 - Bolt (Fuel tank)
3. Pull up the fuel tank.
4. Remove:
 - Center cowlings
 - Air ducts
 - Air filter box
5. Remove:
 - Ignition coil ①

Ignition Spark Gap Test

1. Remove:
 - Lower cowling
 - Bolt (Fuel tank)
2. Disconnect:
 - Ignition coil leads
 - Spark plug leads
3. Connect:
 - Electro Tester (90890-03021) ①

NOTE:

Be sure to use a fully charged battery.

4. Turn the spark plug gap adjuster and increase the gap to the maximum limit unless misfire occurs first.



Minimum Spark Gap: 6 mm (0.24 in)

② Battery (12V)

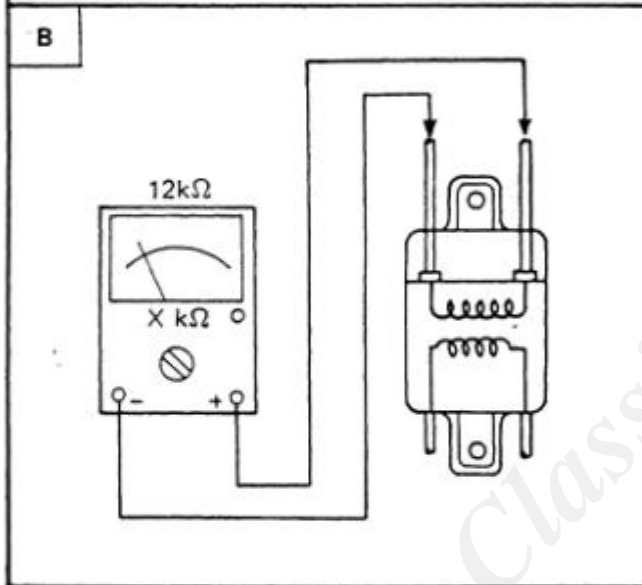
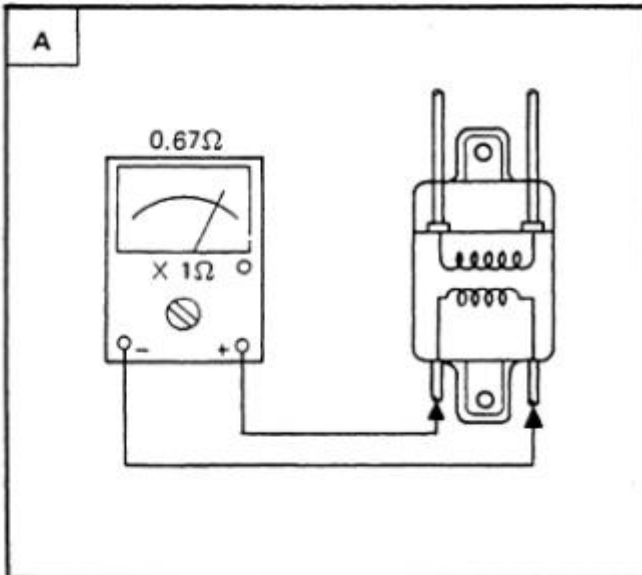

Ignition Coil Resistance Test

1. Connect:
 - Pocket Tester (90890-03104)
2. Measure:
 - Primary coil resistance **A**
 - Secondary coil resistance **B**
 - Spark plug cap resistance.
 Out of specification → Replace.

Primary Coil Resistance **A** :
 $0.67\Omega \pm 20\%$ at 20°C (68°F)
 Secondary Coil Resistance **B** :
 $12\text{ k}\Omega \pm 20\%$ at 20°C (68°F)
 Spark Plug Cap:
 $5\text{ k}\Omega \pm 10\%$ at 20°C (68°F)

Installation

Reverse the removal procedure.

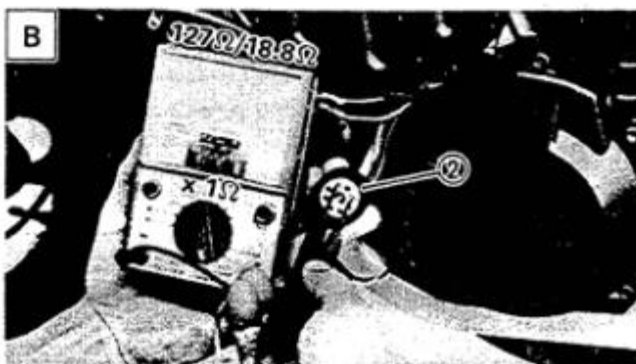

PICKUP AND SOURCE COIL RESISTANCE

1. Remove:
 - Lower cowling
2. Disconnect:
 - Pickup coil connectors ①
 - AC magneto connector ②
3. Measure:
 - Pickup coil resistance **A**
 - Source coil resistance **B**
 Use the Pocket Tester (90890-03104).
 Out of specification → Replace.

Pickup Coil Resistance **A** :
 $112\Omega \pm 20\%$ at 20°C (68°F)
 (White/Green – White/Red)
 Source Coil Resistance **B** :
 $127\Omega \pm 20\%$ at 20°C (68°F)
 (Green – Brown)
 $18.8\Omega \pm 20\%$ at 20°C (68°F)
 (Brown – Red)

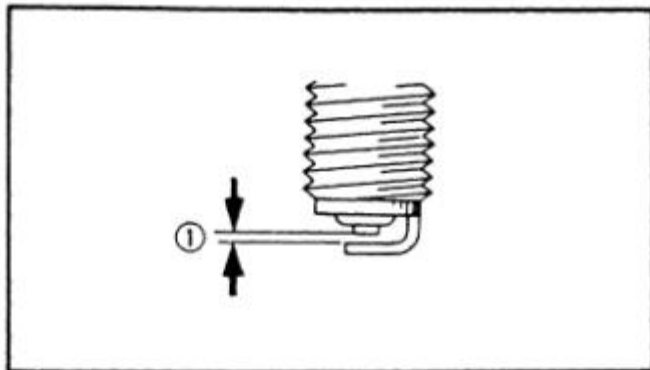
**SPARK PLUG**

1. Inspect:
 - Plug
Burns/Fouling/Wear → Replace.
2. Measure:
 - Electrode gap ①
Out of specification → Clean off carbon and regap.

**Electrode Gap:**

0.6 ~ 0.7 mm (0.024 ~ 0.028 in)

NOTE:

Clean and inspect spark plugs every 6,000 km (4,000 mi) and replace after initial 12,000 km (8,000 mi).

Type:

BR9HS (NGK),
W27FSR (NIPPONDENSO)

**Spark plug:**

20 Nm (2.0 m·kg, 14 ft·lb)



CHARGING SYSTEM

Below circuit diagram shows charging circuit.

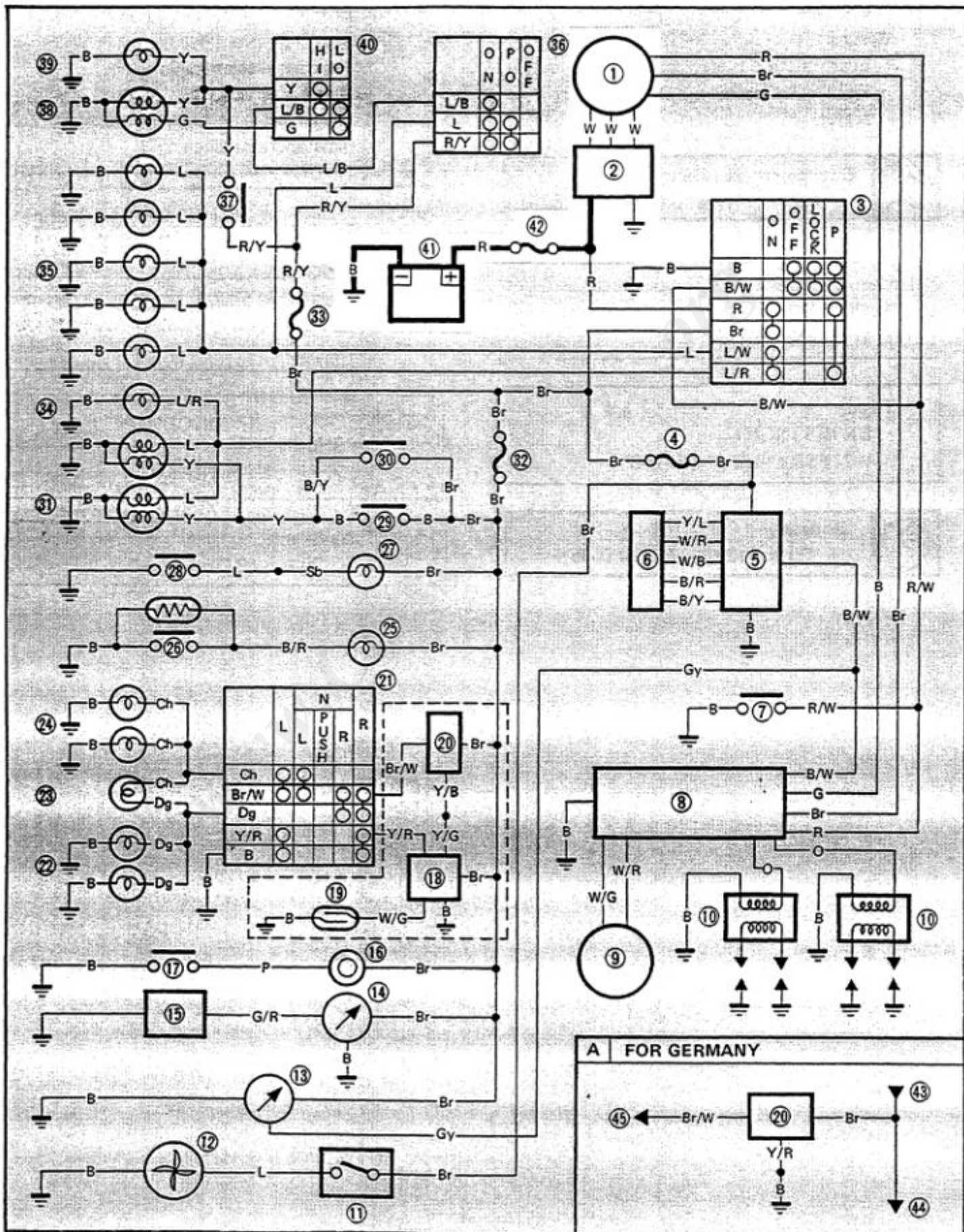

1. AC magneto
2. Rectifier/Regulator

41. Battery
42. Fuse "MAIN" (20A)

SYSTEME DE CHARGE

Le schéma ci-dessous montre le circuit de charge.

1. Alternateur
2. Redresseur/Régulateur

41. Batterie
42. Fusible principal "MAIN" (20A)

LADESYSTEM

Unteres Schaltbild zeigt die Aufladeschaltung.

1. Wechselstrom-Magnetzünder
2. Gleichrichter/Spannung sregler

41. Batterie
42. Sicherung "MAIN" (20A)

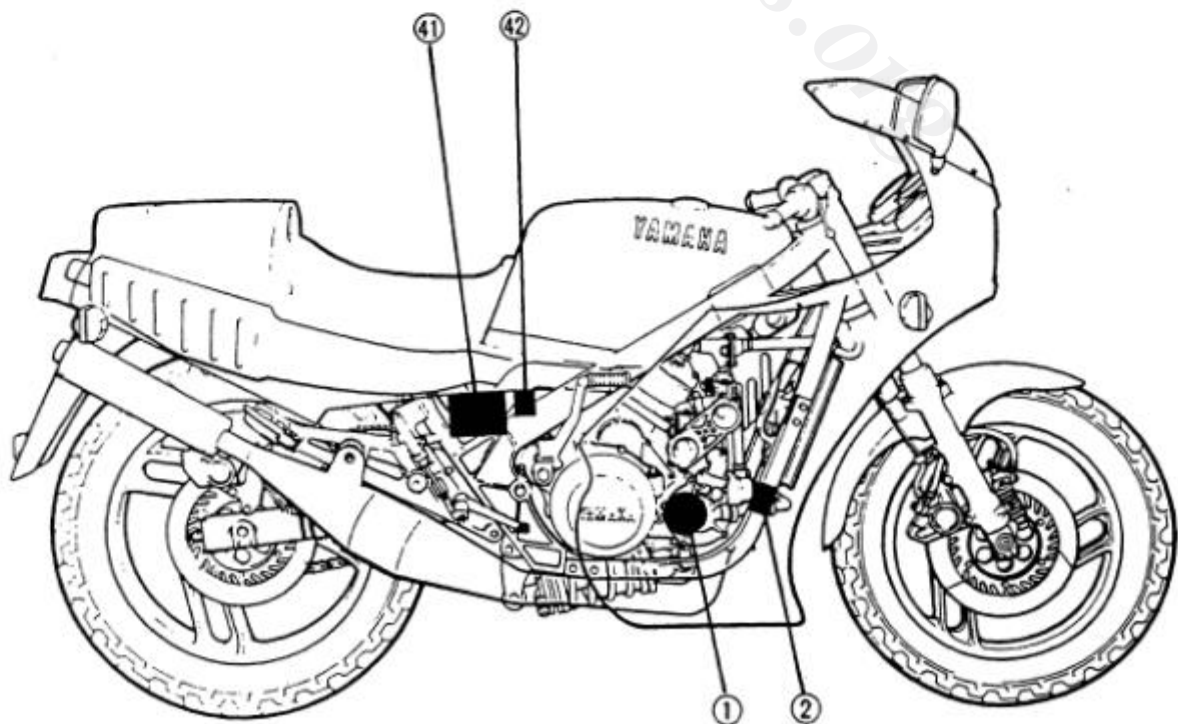



TROUBLESHOOTING CHART

THE BATTERY IS NOT CHARGED

Remove the seat, rear cowling, side cover, and battery cover.

Measure the battery for voltage and specific gravity.
 Battery voltage: More than 12V
 Specific gravity: 1,280

Recharge the battery.

Connect the Pocket Tester to the battery to measure the generator voltage.

Generator Voltage:
 more than 15.3V

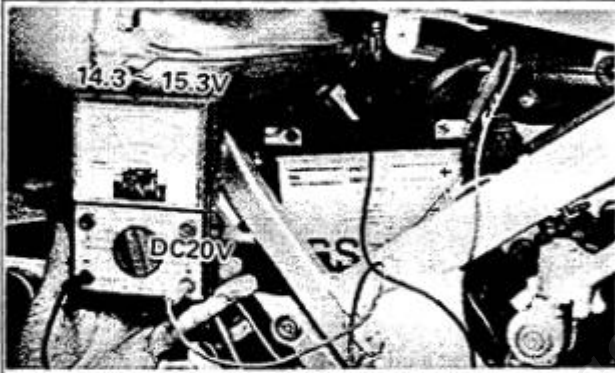

Replace the rectifier/regulator ①.

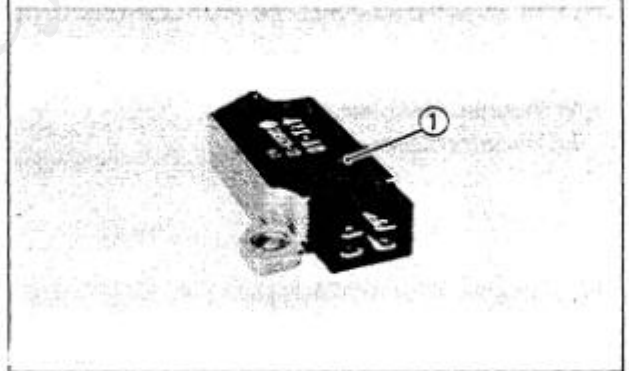

Start the engine and accelerate to about 2,000 r/min or more.

Generator Voltage:
 Less than 14.3V

Out of specification → Replace the coil assembly.

Disconnect the AC magneto lead connector ① and measure the stator coil resistance.

Stator coil [A] :
 $0.4\Omega \pm 20\%$ at 20°C (68°F)
 (White – White)

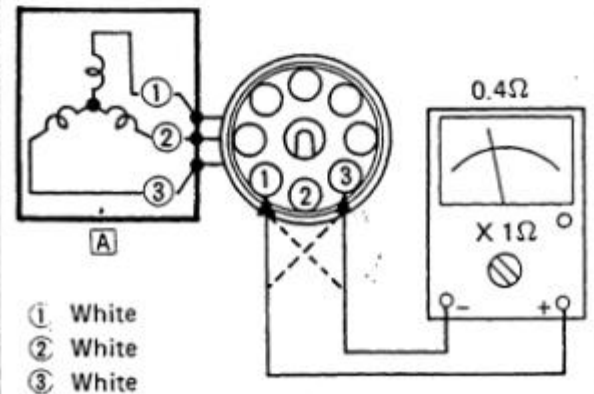
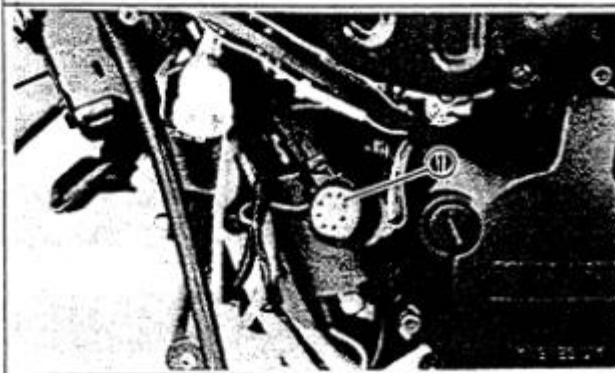

Replace the rectifier/regulator.



GENERATOR VOLTAGE INSPECTION

1. Remove:
 - Rear cowling
 - Side cover
 - Battery cover
2. Connect:
 - Pocket Tester (90890-03104)
3. Start the engine and accelerate the engine to approximately 2,000 r/min.
4. Measure:
 - Generator voltage
Out of specification → Replace the stator coil and/or rectifier/regulator.



Generator Voltage:
14.3 ~ 15.3V

CAUTION:

Never disconnect the wires from the battery while the generator is operating. If the battery is disconnected, the voltage across the generator terminals will increase and damage the semi-conductors.

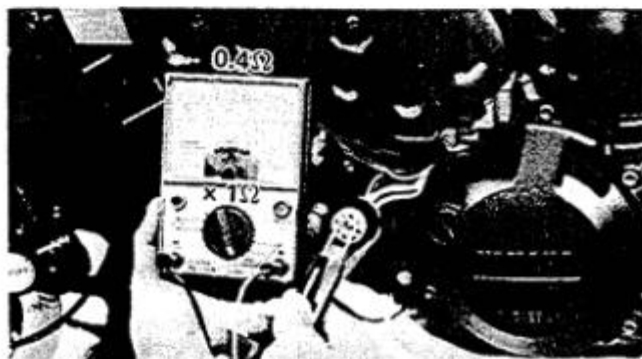
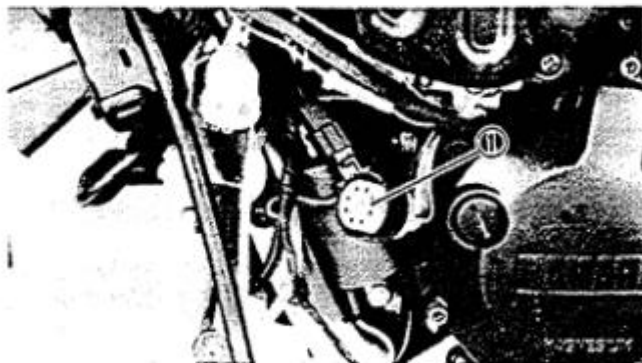

STATOR COIL INSPECTION

1. Remove:
 - Lower cowling
2. Disconnect:
 - AC magneto connector ①
3. Connect:
 - Pocket Tester (90890-03104)
4. Measure:
 - Stator coil resistance
Out of specification → Replace stator coil assembly.



Stator Coil Resistance:
 $0.4\Omega \pm 20\%$ at 20°C (68°F)
(White – White)

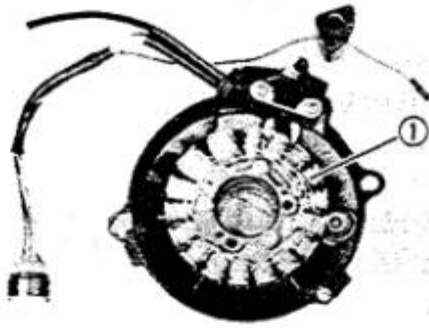

① Stator coil assembly

RECTIFIER INSPECTION

1. Remove:
 - Lower cowling
2. Disconnect:
 - Rectifier/regulator lead
3. Remove:
 - Rectifier/regulator
4. Check:
 - Diodes (All)

Use the Pocket Tester (90890-03104).
Defective element → Replace rectifier/regulator.

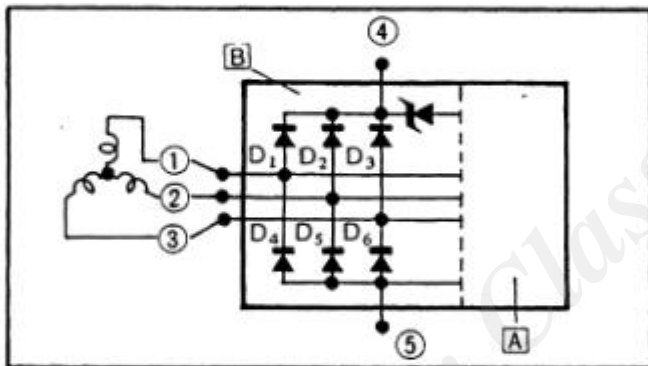

- ① White
 - ② White
 - ③ White
 - ④ Red
 - ⑤ Ground
- [A] IC Regulator
 - [B] Rectifier

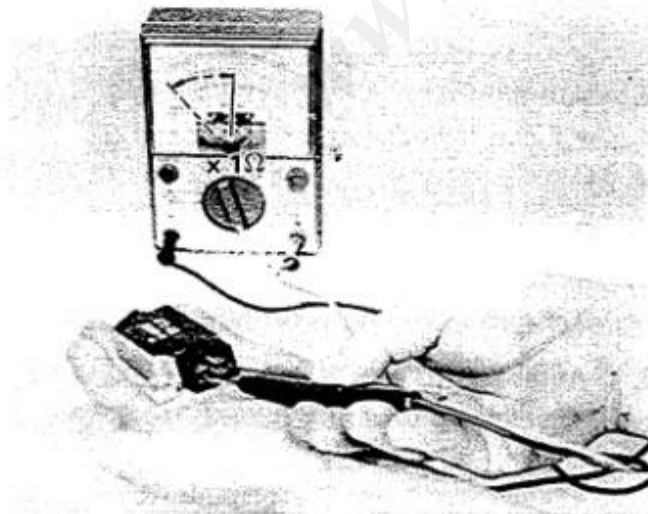

Checking element	Pocket tester connecting point		Good
	(+) (Red)	(-) (Black)	
D ₁	④	①	○
	①	④	x
D ₂	④	②	○
	②	④	x
D ₃	④	③	○
	③	④	x
D ₄	⑤	①	x
	①	⑤	○
D ₅	⑤	②	x
	②	⑤	○
D ₆	⑤	③	x
	③	⑤	○

○ : Continuity
X : Discontinuity (∞)

**CAUTION:**

Do not overcharge rectifier or damage may result.

Avoid:

- A short circuit
- Inverting + and – battery leads
- Direct connection of rectifier to battery

NOTE:

The results of "O" and "X" should be reversed according to the polarity of the specific Pocket Tester used.

BATTERY**CAUTION:**

To insure maximum battery performance be sure to:

- Charge a new battery before use.
- Maintain proper electrolyte level.
- Charge at proper current; 0.55 amps/10 hrs. or until the specific gravity reaches 1.280 at 20°C (68°F).

Failure to observe these points will result in a shortened battery life.

WARNING:

Battery electrolyte is dangerous; it contains sulfuric acid and therefore is poisonous and highly caustic.

Always follow these preventive measures:

- Avoid bodily contact with electrolyte as it can cause severe burns or permanent eye injury.
- Wear protective eye gear when handling or working near batteries.

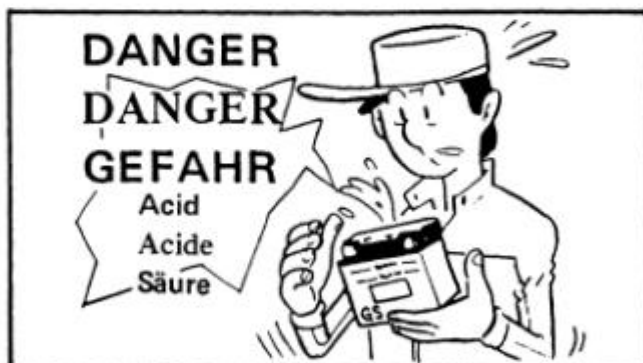

**Antidote (EXTERNAL):**

- SKIN – Flush with water.
- EYES – Flush with water for 15 minutes and get immediate medical attention.

Antidote (INTERNAL):

- Drink large quantities of water or milk and follow with milk of magnesia, beaten egg, or vegetable oil.

Get immediate medical attention.

Batteries also generate explosive hydrogen gas, therefore you should always follow these preventive measures:

- Charge batteries in a well-ventilated area.
- Keep batteries away from fire, sparks, or open flames (e.g., welding equipment, lighted cigarettes, etc.)
- DO NOT SMOKE when charging or handling batteries.

KEEP BATTERIES AND ELECTROLYTE OUT OF REACH OF CHILDREN:

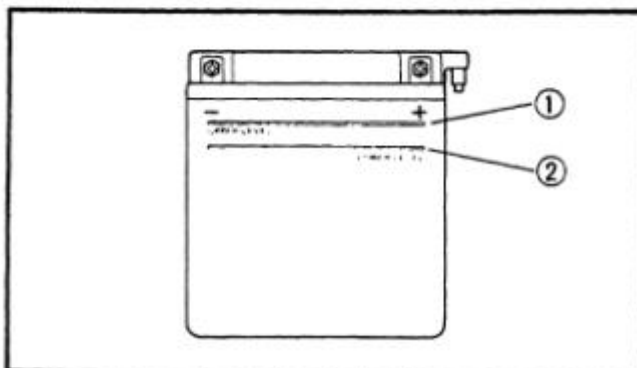
**Inspection**

1. Remove:
 - Seat
 - Rear cowling
 - Side cover
 - Battery cover
 - Battery
 Disconnect negative lead first.
2. Inspect:
 - Battery fluid level
Below lower level → Add distilled water.

NOTE:

Replace the battery if:

- Battery voltage will not rise to a specific value or bubbles fail to rise even after many hours of charging.
- Sulfation of one or more cells occurs, as indicated by the plates turning white, or an accumulation of material exists in the bottom of the cell.
- Specific gravity readings after a long, slow charge indicate one cell to be lower than the rest.

- ① UPPER level
- ② LOWER level

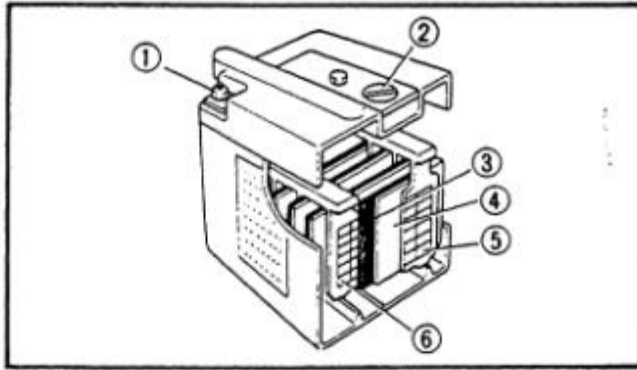

- Warpage or buckling of plates or insulators is evident.

- ① Terminal
- ② Cap
- ③ Insulator
- ④ Separation plate
- ⑤ Negative electrode
- ⑥ Positive electrode

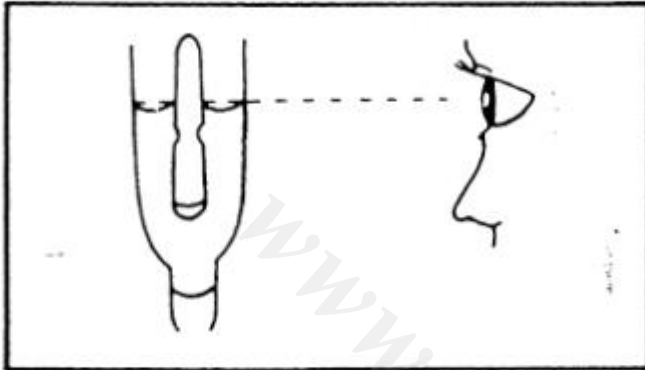

3. Measure:
 - Specific gravity:
 - Less than 1.280 → Recharge battery.
4. Install:
 - Battery
 - Connect positive lead first.
5. Check:
 - Breather hose ①
 - Improper routing → Correct.
 - Obstruction/Damage → Replace.

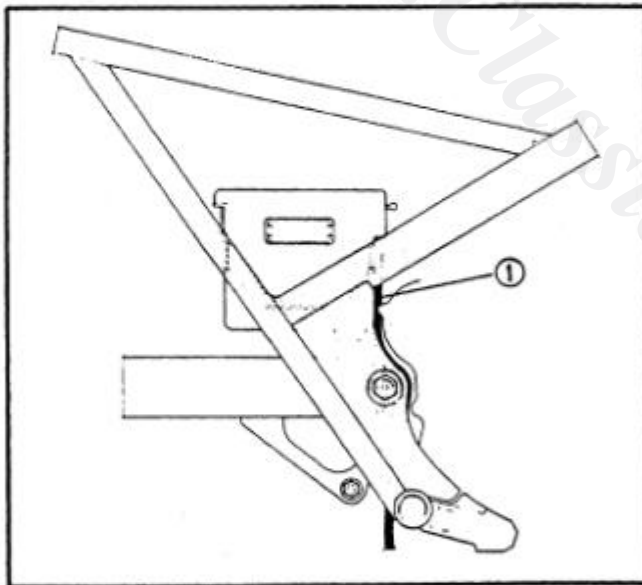

Battery Storage

The battery should be stored if the motorcycle is not to be used for a long period.

1. Remove:
 - Battery

Battery storage and maintenance tips:

- Recharge the battery periodically.
- Store the battery in a cool, dry place.
- Recharge the battery before reinstalling.

Battery	12N 5.5-3B
Electrolyte	Specific gravity: 1.280
Initial charging rate	0.55 amp for 10 hours (new battery)
Recharging rate	10 hours (or until specific gravity reaches 1.280)
Refill fluid	Distilled water (to maximum level line)
Refill period	Check once per month (or more often as required)



LIGHTING SYSTEM

Below circuit diagram shows lighting circuit.

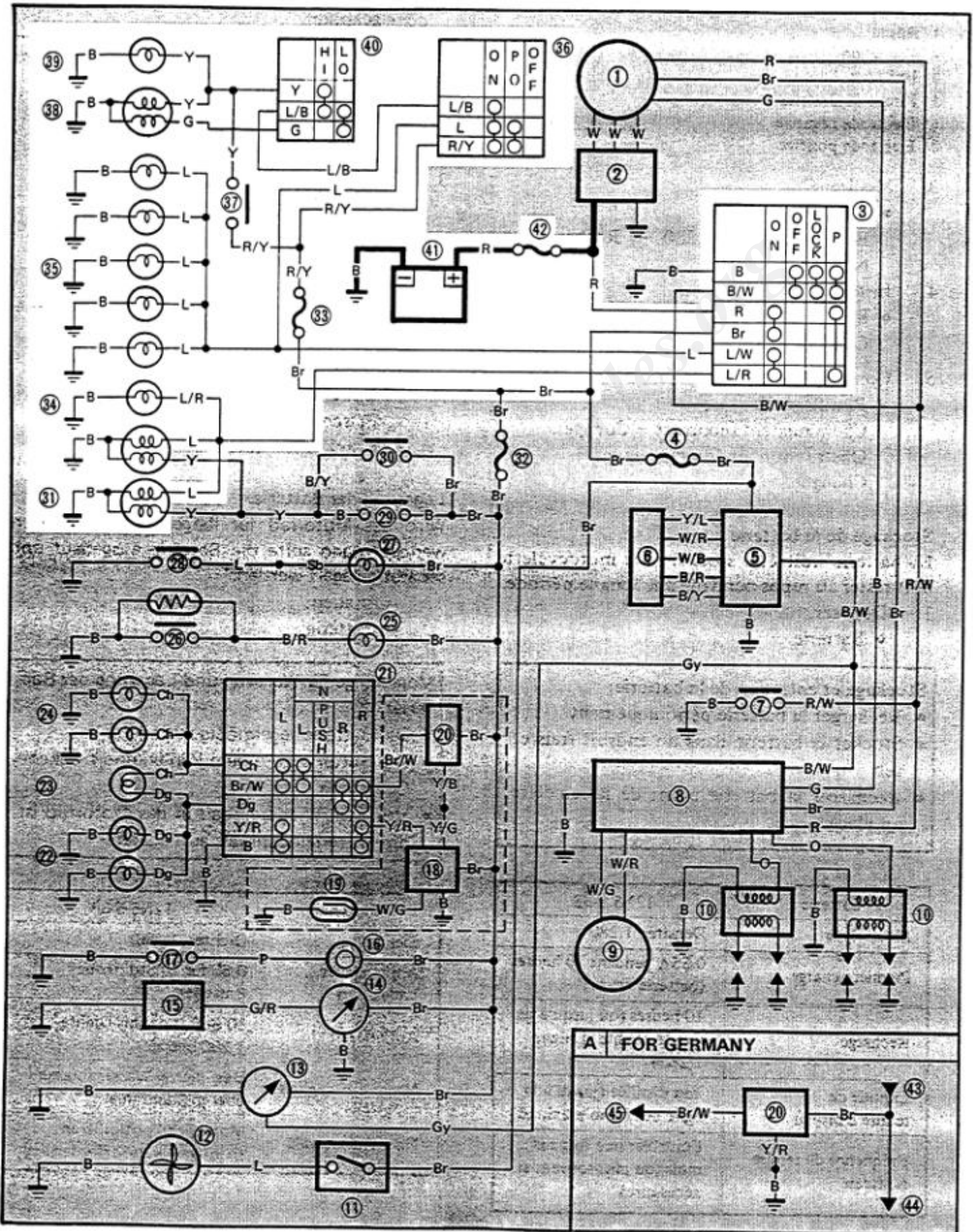



- 3. Main switch
- 31. Tail/Brake light
- 33. Fuse "HEAD" (15A)
- 34. Auxiliary light
- 35. Meter light
- 36. "LIGHTS" switch

- 37. "PASS" switch
- 38. Headlight
- 39. "HIGH BEAM" indicator light
- 40. "LIGHTS" (Dimmer) switch
- 41. Battery
- 42. Fuse "MAIN" (20A)

SYSTEME D'ECLAIRAGE

Le schéma ci-dessous montre le circuit d'éclairage.

- 3. Contacteur à clé
- 31. Feu arrière/stop
- 33. Fusible de phare "HEAD" (15A)
- 34. Témoin auxiliaire
- 35. Eclairage de compteur
- 36. Commutateur d'éclairage "LIGHTS"

- 37. Commutateur d'appel de phare "PASS"
- 38. Phare
- 39. Indicateur de feu de route "HIGH BEAM"
- 40. Commutateur de feu de route/feu de croisement "LIGHTS"
- 41. Batterie
- 42. Fusible principal "MAIN" (20A)

BELEUCHTUNGSANLAGE

Unteres Schaltbild zeigt die Beleuchtungsschaltung.

- 3. Hauptschalter
- 31. Schluß/Bremsleuchte
- 33. Sicherung "HEAD" (15A)
- 34. Nummernschildbeleuchtung
- 35. Instrumenten-Kontrolllampe
- 36. Lichtschalter "LIGHTS"

- 37. Lichthupenschalter "PASS"
- 38. Scheinwerfer
- 39. Fernlicht-Kontrolllampe "HIGH BEAM"
- 40. Lichtschalter "LIGHTS" (Dimmer)
- 41. Batterie
- 42. Sicherung "MAIN" (20A)

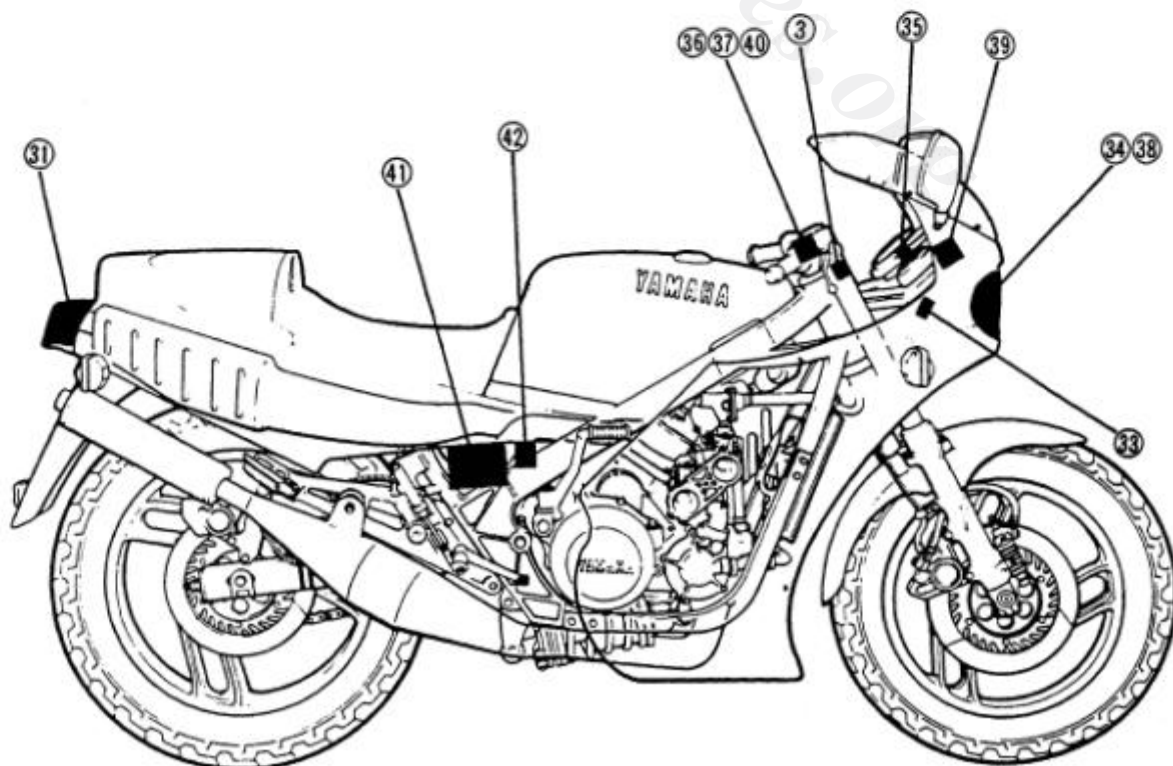

**LIGHTING TESTS AND CHECKS**

The battery provides power for operation of the headlight, taillight, and meter lights. If none of the above fail to operate, proceed further. Low battery voltage indicates either a faulty battery, low battery fluid level, or a defective charging system.

Also check fuse condition. Replace any "open" fuses. There are individual fuses for various circuits (see complete Circuit Diagram).

NOTE: _____

Check each bulb first before performing the following check.

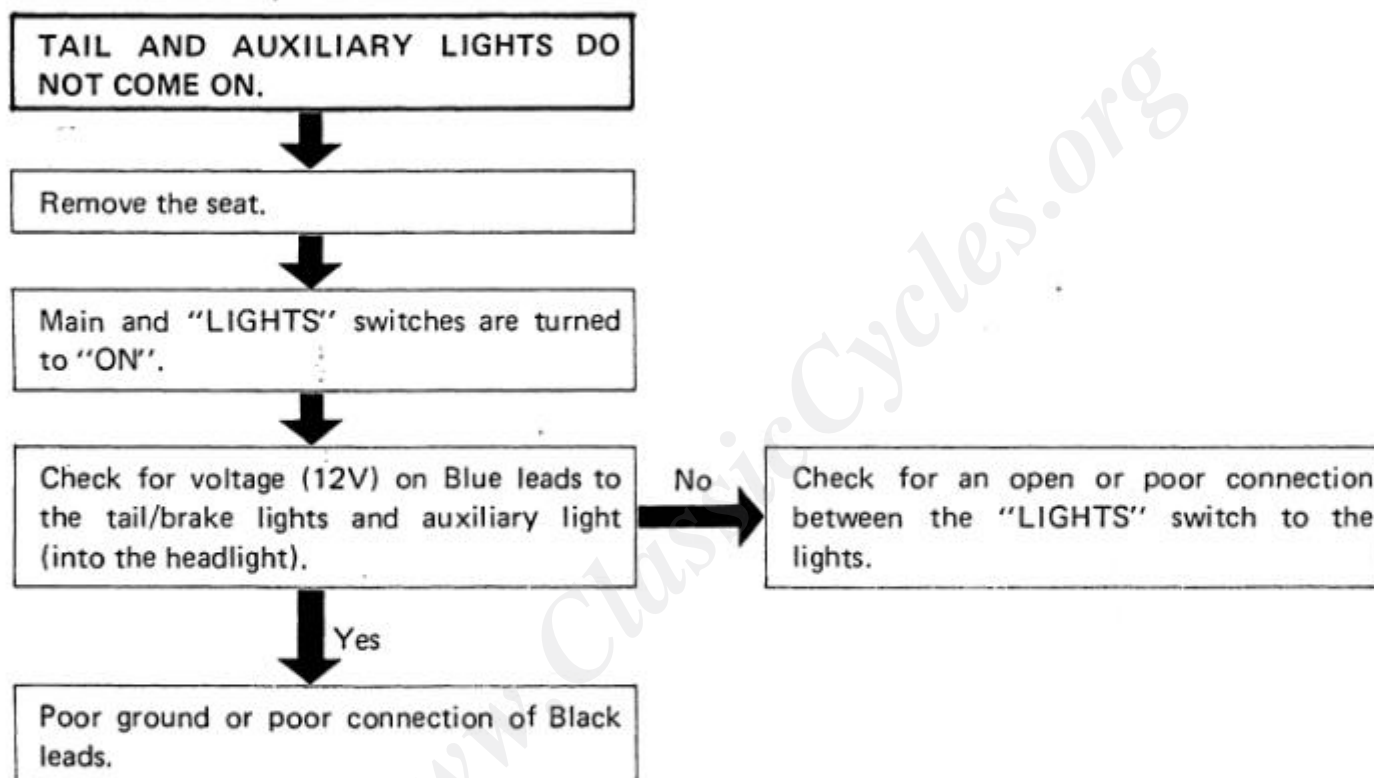
TROUBLESHOOTING CHART (1)



TROUBLESHOOTING CHART (2)

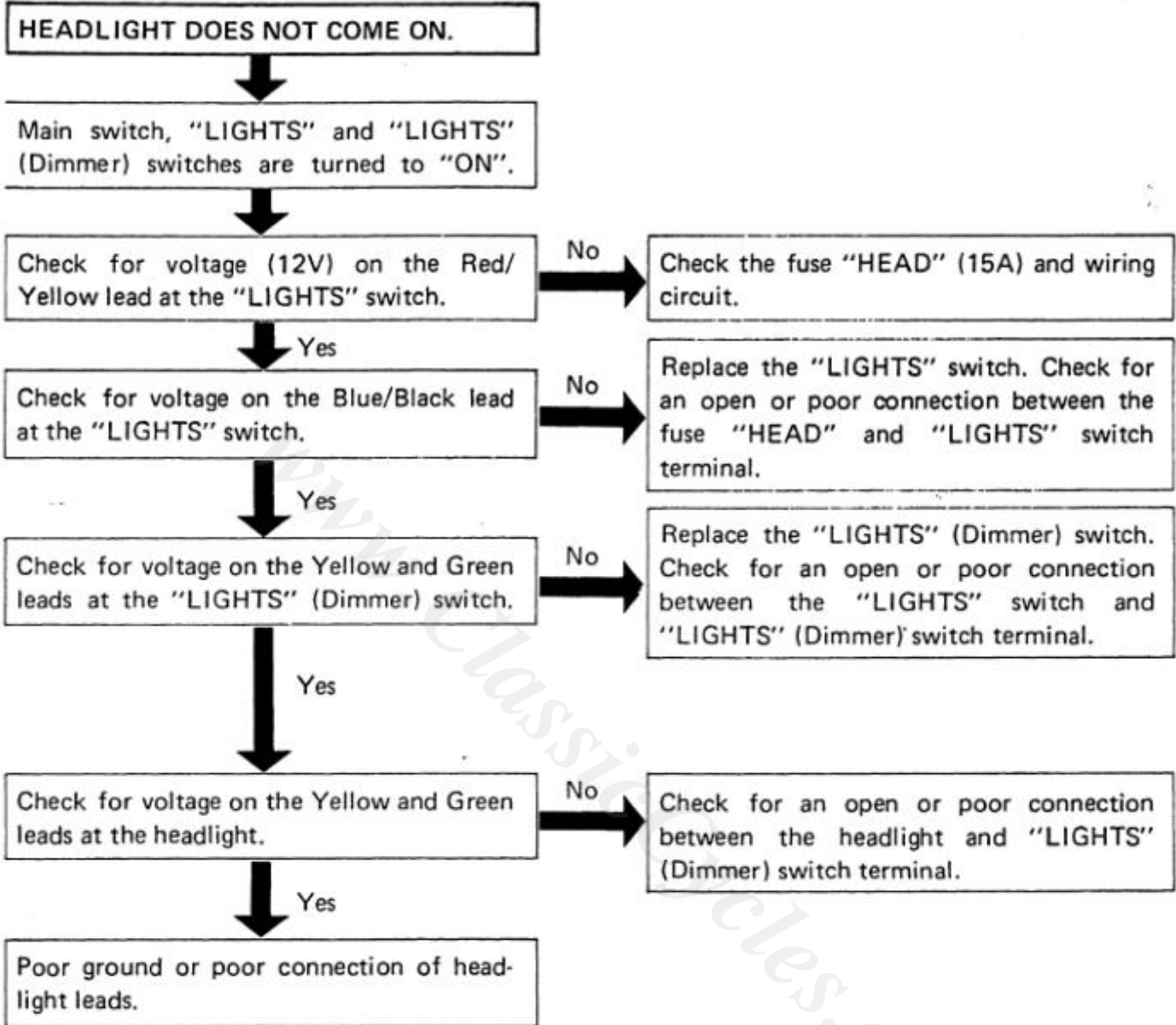



HEADLIGHT ADJUSTMENT

1. Remove:
 - Meter assembly

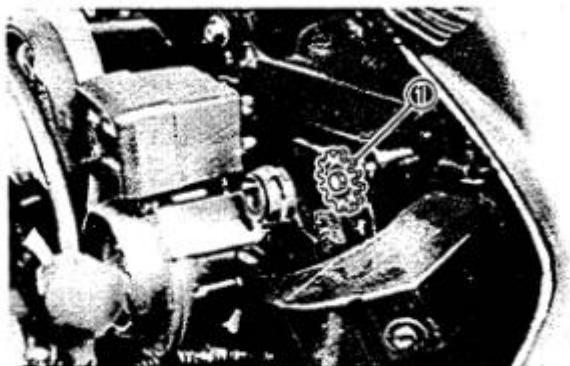

2. Adjust:
 - Headlight (Horizontally)

Horizontal Adjustment	
Right	Turn the adjuster ① clockwise
Left	Turn the adjuster ① counterclockwise

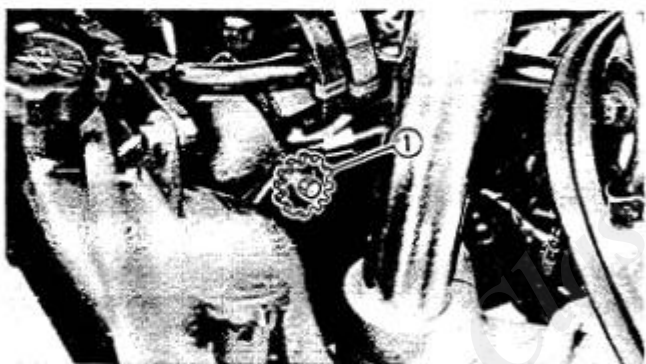

3. Adjust:
 - Headlight (Vertically)

Vertical Adjustment	
Higher	Turn the adjuster ① counterclockwise
Lower	Turn the adjuster ① clockwise

SYSTEME DE SIGNALISATION SIGNALANLAGE



- | | | |
|---|-------------------------------|------------------------------|
| 3. Main switch | 21. "TURN" signal switch | 30. Front brake switch |
| 13. Tachometer | 22. Flasher light (Right) | 31. Tail/Brake light |
| 16. Horn | 23. "TURN" indicator light | 32. Fuse "SIGNAL" (10A) |
| 17. "HORN" switch | 24. Flasher light (Left) | 41. Battery |
| 18. Flasher cancelling unit
(Except for Germany) | 25. "OIL" indicator light | 42. Fuse "MAIN" (20A) |
| 19. Reed switch
(Except for Germany) | 26. Oil level switch | 43. From fuse "SIGNAL" (10A) |
| 20. Flasher relay | 27. "NEUTRAL" indicator light | 44. To horn |
| | 28. Neutral switch | 45. To "TURN" signal switch |
| | 29. Rear brake switch | A FOR GERMANY |

SYSTEME DE SIGNALISATION

Le schéma ci-dessous montre le circuit de signalisation.

- | | | |
|--|---|---|
| 3. Contacteur à clé | 21. Commutateur des clignoteurs
"TURN" | 30. Contacteur de frein avant |
| 13. Compte-tours | 22. Clignotant (Droit) | 31. Feu arrière/stop |
| 16. Avertisseur | 23. Indicateur de clignotant "TURN" | 32. Fusible de signalisation
"SIGNAL" (10A) |
| 17. Commutateur d'avertisseur "HORN" | 24. Clignotant (Gauche) | 41. Batterie |
| 18. Unité d'arrêt des clignotants
(Excepté Allemagne) | 25. Indicateur de niveau d'huile "OIL" | 42. Fusible principal "MAIN" (20A) |
| 19. Commutateur à lame
(Excepté Allemagne) | 26. Contacteur de niveau d'huile | 43. Du fusible "SIGNAL" (10A) |
| 20. Relais des clignotants | 27. Indicateur de point mort
"NEUTRAL" | 44. Vers l'avertisseur |
| | 28. Contacteur de point mort | 45. Vers le commutateur des
clignoteurs "TURN" |
| | 29. Contacteur de frein arrière | A ALLEMAGNE |

SIGNALANLAGE

Unteres Schaltbild zeigt die Signalschaltung.

- | | | |
|--|-------------------------------------|-----------------------------------|
| 3. Hauptschalter | 21. Blinklichtschalter "TURN" | 30. Vorderrad-Bremslichtschalter |
| 13. Drehzahlmesser | 22. Blinklicht (Rechts) | 31. Schluß/Bremsleuchte |
| 16. Hupe | 23. Blinklicht-Kontrollampe "TURN" | 32. Sicherung "SIGNAL" (10A) |
| 17. Signalhornknopf "HORN" | 24. Blinklicht (Links) | 41. Batterie |
| 18. Blinkleuchten-Abschaltautomatik
(Ausgenommen für Deutschland) | 25. Ölstand-Kontrollampe "OIL" | 42. Sicherung "MAIN" (20A) |
| 19. Zungenschalter
(Ausgenommen für Deutschland) | 26. Ölstandscharter | 43. Von Sicherung "SIGNAL" (10A) |
| 20. Blinkerrelais | 27. Leerlauf-Kontrollampe "NEUTRAL" | 44. Zum Signalhorn |
| | 28. Leerlaufschalter | 45. Zum Blinklichtschalter "TURN" |
| | 29. Hinterrad-Bremslichtschalter | A FÜR DEUTSCHLAND |

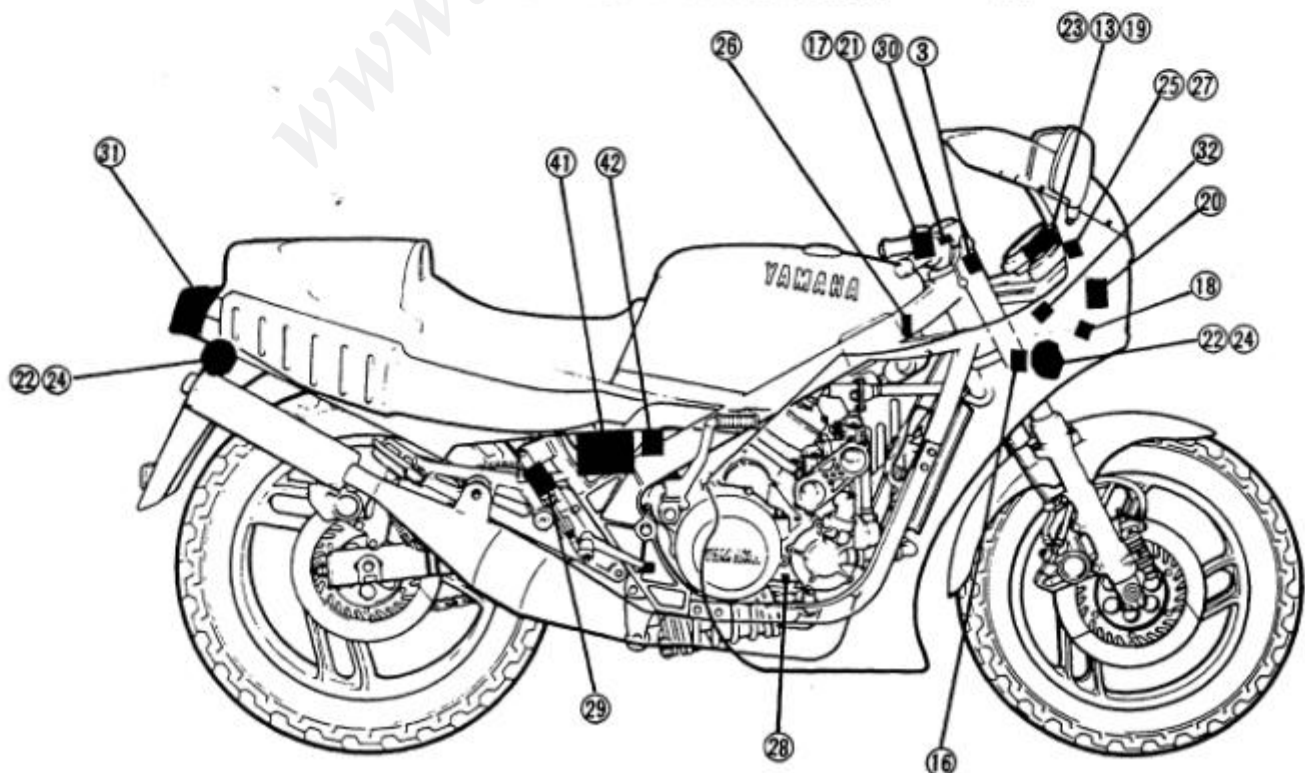



TROUBLESHOOTING CHART (1)

FLASHER LIGHTS DO NOT COME ON.

Remove the meter assembly, and disconnect the flasher relay ①, connector.



Turn the main switch "ON".

Check for the battery voltage (12V) on the Brown lead from the wire harness.

No

Check for an open or poor connection between the flasher relay and main switch.

Yes

Connect the Brown lead and Brown/White lead; use a jumper lead ①.



Turn the "TURN" switch to "L" and/or "R", and check if the lights come on.

If any flasher light does not come on, replace the bulb.

If all flasher lights come on, replace the flasher relay.



TROUBLESHOOTING CHART (2)

FLASHER CANCELLING UNIT DOES NOT OPERATE. (Except for Germany)

Remove the meter assembly and disconnect the flasher cancelling unit ① connector.



Turn the main switch "ON" and operate the handlebar switch. If the signal operates normally in "L", "R", and "OFF", the flasher relay and bulbs are in good condition.

No

Replace the flasher relay and/or bulb(s).

Yes

Connect the Pocket Tester ① to the White/Green ② and Black ③ leads on the wire harness. Lift the front wheel and rotate the wheel by hand, and check for reed switch continuity.

Out of specification → Replace the speedometer assembly.

Out of specification → Replace the speedometer assembly.

If the tester needle swings back and forth between "0Ω" and "∞".

Flasher cancelling unit is faulty, replace the unit.

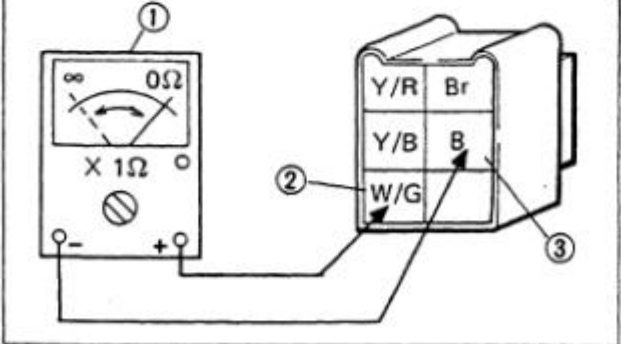



TROUBLESHOOTING CHART (3)

"OIL" INDICATOR LIGHT DOES NOT COME ON.

Turn the main switch "ON".

Disconnect the oil level switch connector ① and connect the Black/Red lead ② from the wire harness to "ground" on the frame; use a jumper lead ③.

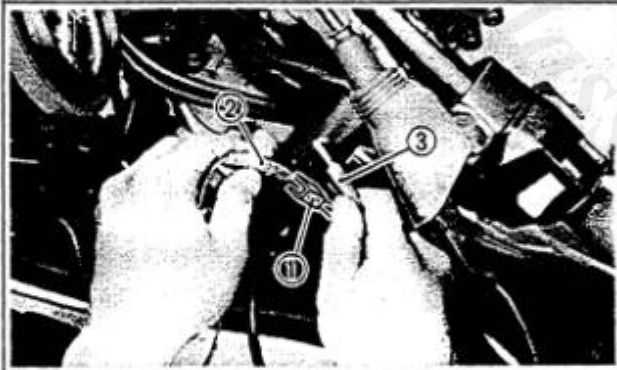

"OIL" indicator light comes on.
comes on.

No

Replace the bulb (12V-3.4W) and/or check for an open or poor connection between the indicator light connector and oil level switch.

Yes

Replace the oil level switch.

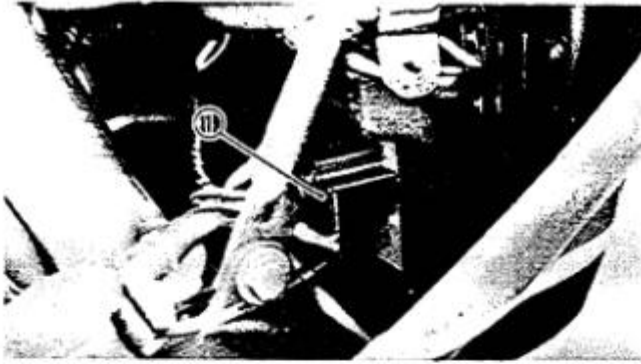

SELF-CANCELLING FLASHER SYSTEM (Except for Germany)

Description

The flasher cancelling unit ① turns off the turn signal after a period of time or distance involved in turning or changing lanes. Generally, the signal will cancel after either 10 seconds, or 150 meters (490 feet), whichever is greater. At very low speed, the function is determined by distance; at high speed, especially when changing speeds, the cancelling determination is a combination of both times and distance. The self-cancelling mechanism only operates when the motorcycle is moving; thus the signal will not self-cancel while you are stopped at an intersection.

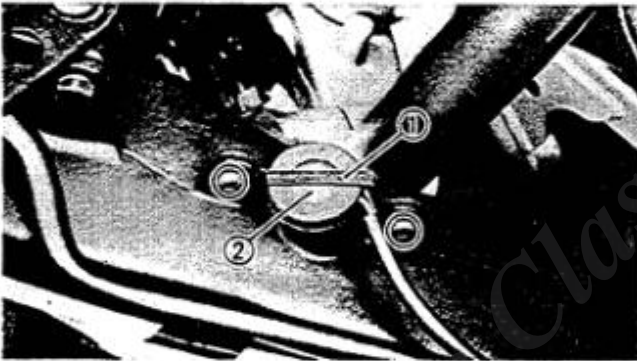

OIL LEVEL SWITCH

1. Remove:

- Retainer ①
- Oil level switch ②

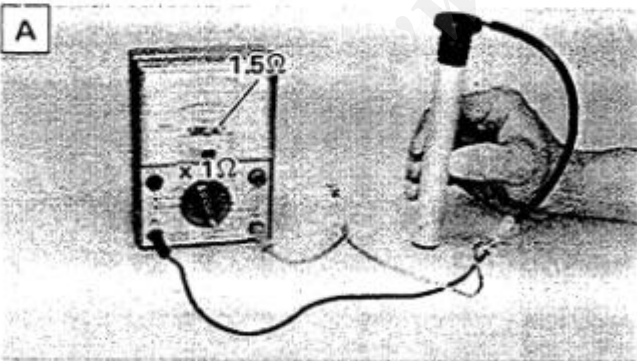

2. Measure:

- Oil level switch resistance
Use the Pocket Tester (90890-03104)
Out of specification → Replace.



Oil Level Switch:

- Ⓐ Float is Down: Approx. 1.5Ω
- Ⓑ Float is Up: Approx. 22Ω

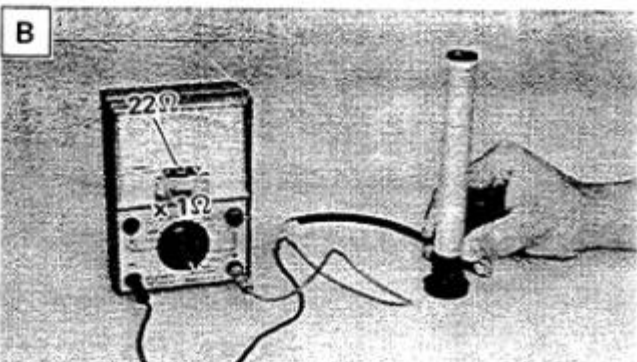

3. Install:

- Oil level switch
- Retainer



SWITCHES

Switches may be checked for continuity with the Pocket Tester (90890-03104) on the "ohm x 1" position.

A Main Switch						
① Switch Position	② Lead Color					
	B	B/W	R	Br	L/W	L/R
ON			○—○		○—○	
OFF	○—○					
LOCK	○—○					
P	○—○			○—○		

B "ENGINE STOP" Switch		
① Switch Position	② Lead Color	
	B	R/W
OFF		
RUN	○—○	

C "LIGHTS" (Dimmer) Switch			
① Switch Position	② Lead Color		
	Y	L/B	G
HI	○—○		
LO		○—○	

D "TURN" Switch					
① Switch Position	② Lead Color				
	Ch	Br/W	Dg	Y/R	B
L	○—○			○—○	
L → N	○—○				
④N → Push					
R → N		○—○			
R		○—○		○—○	

E "HORN" Switch		
③ Button Position	② Lead Color	
	P	B
PUSH	○—○	
OFF		

F "LIGHTS" Switch			
① Switch Position	② Lead Color		
	R/Y	L	L/B
OFF			
PO	○—○		
ON	○—○	○—○	○—○

G "PASS" Switch		
③ Button Position	② Lead Color	
	Y	Y
PUSH	○—○	
OFF		



Br	Brown	G	Green	Y/B	Yellow/Black
R	Red	Dg	Dark Green	W/G	White/Green
W	White	Ch	Chocolate	Y/R	Yellow/Red
B	Black	G/R	Green/Red	R/W	Red/White
L	Blue	Br/W	Brown/White	L/R	Blue/Red
Sb	Sky Blue	B/Y	Black/Yellow	G/Y	Green/Yellow
Y	Yellow	L/W	Blue/White	B/R	Black/Red
P	Pink	L/B	Blue/Red	Gy	Gray
O	Orange	R/Y	Red/Yellow	Y/L	Yellow/Blue
B/W	Black/White	W/R	White/Red	W/B	White/Black
L/Y	Blue/Yellow				



COOLING SYSTEM

Below circuit diagram shows cooling circuit.

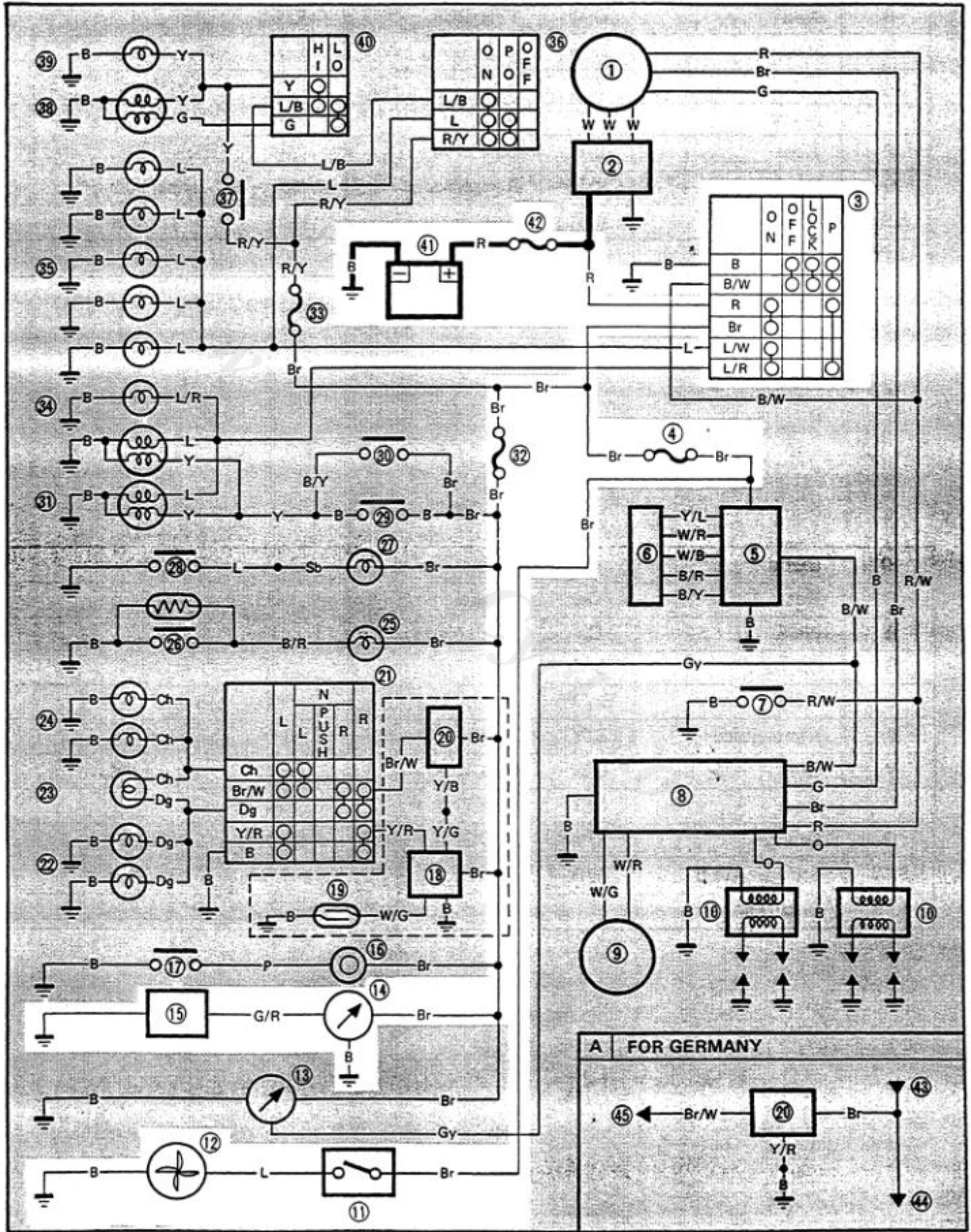

- | | |
|-----------------------|-------------------------|
| 3. Main switch | 15. Thermo unit |
| 4. Fuse "YPVS" (10A) | 32. Fuse "SIGNAL" (10A) |
| 11. Thermo switch | 41. Battery |
| 12. Fan motor | 42. Fuse "MAIN" (20A) |
| 14. Temperature gauge | |

SYSTEME DE REFROIDISSEMENT

Le schéma ci-dessous montre le circuit de refroidissement.

- | | |
|-------------------------------|---|
| 3. Contacteur à clé | 15. Sonde thermique |
| 4. Fusible "YPVS" (10A) | 32. Fusible de signalisation "SIGNAL" (10A) |
| 11. Thermocontact | 41. Batterie |
| 12. Moteur de ventilateur | 42. Fusible principal "MAIN" (20A) |
| 14. Indicateur de température | |

KÜHLANLAGE

Der nachfolgende Schaltplan zeigt den Schaltkreis der Kühlanlage.

- | | |
|---------------------------|------------------------------|
| 3. Hauptschalter | 15. Temperaturgeber |
| 4. Sicherung "YPVS" (10A) | 32. Sicherung "SIGNAL" (10A) |
| 11. Thermostatschalter | 41. Batterie |
| 12. Lüftermotor | 42. Sicherung "MAIN" (20A) |
| 14. Temperaturanzeige | |

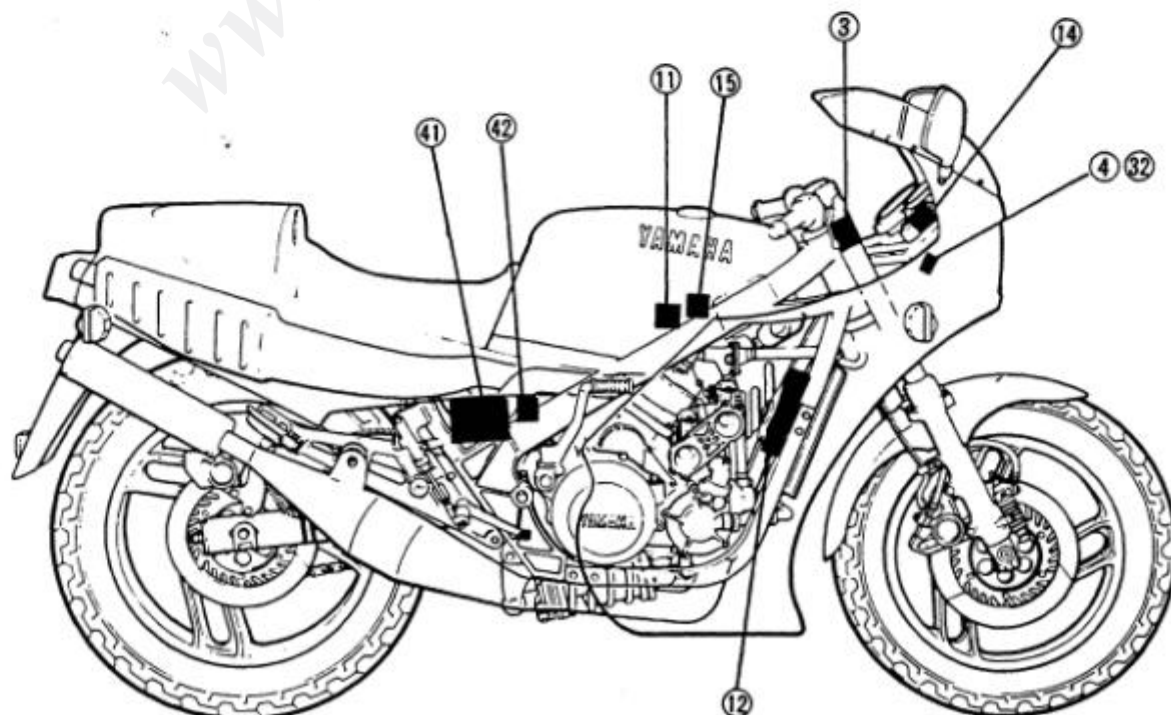



TROUBLESHOOTING CHART (1)

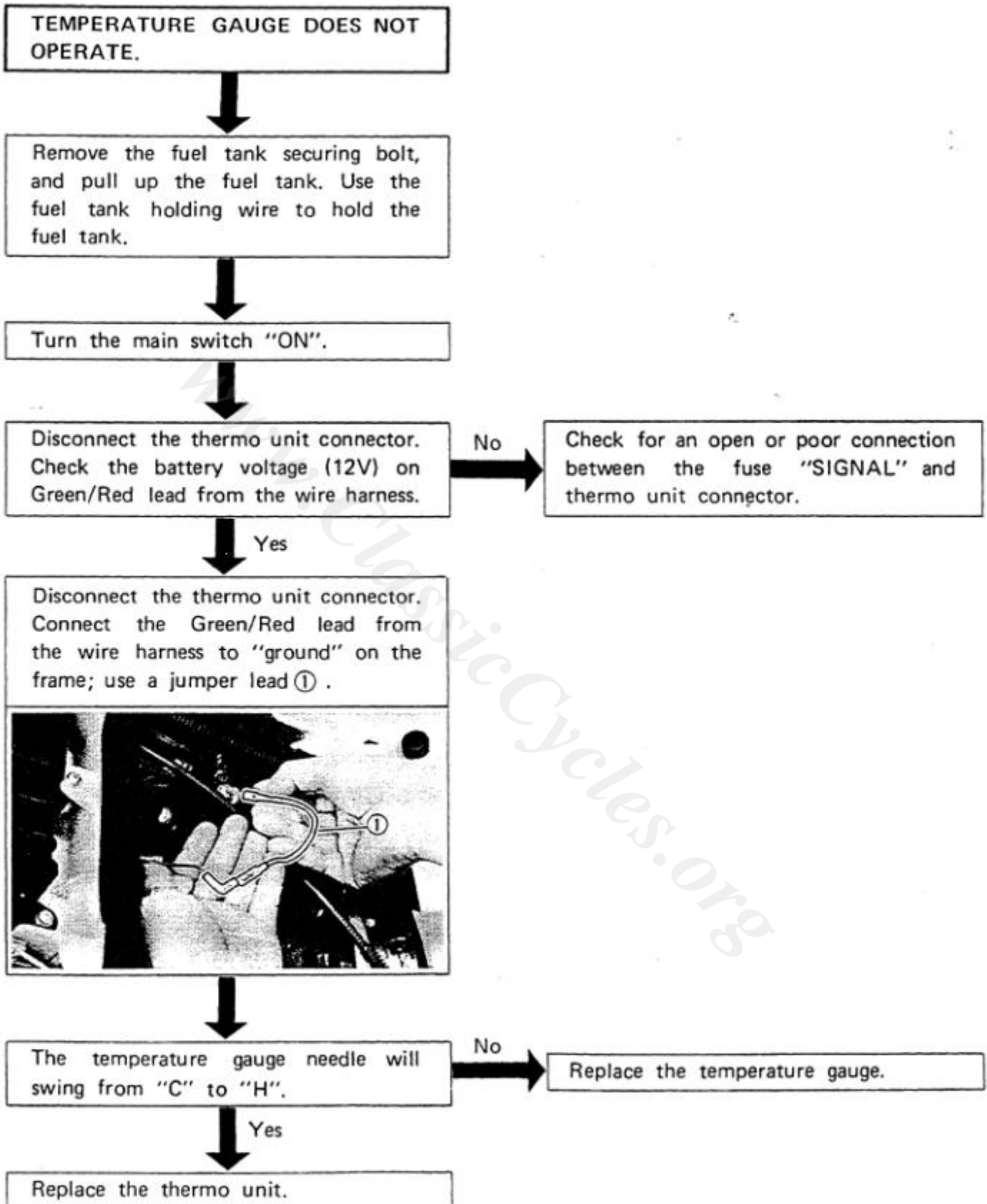

**TROUBLESHOOTING CHART (2)**

ELECTRIC FAN MOTOR DOES NOT OPERATE.

Disconnect the thermo switch ① lead.

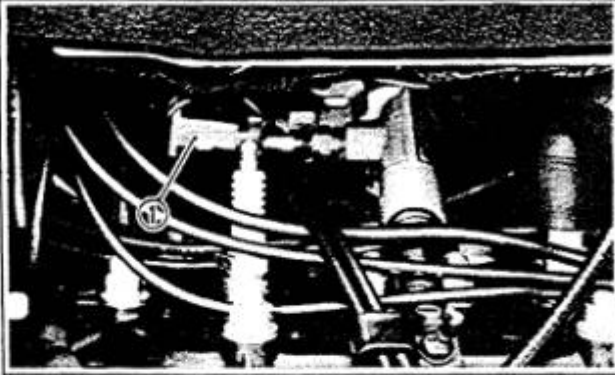

Check for the battery voltage (12V) on Brown lead from the wire harness.

Check for an open or poor connection between the main switch and thermo switch connector.

Connect the Brown lead and Blue lead; use a jump lead ①.

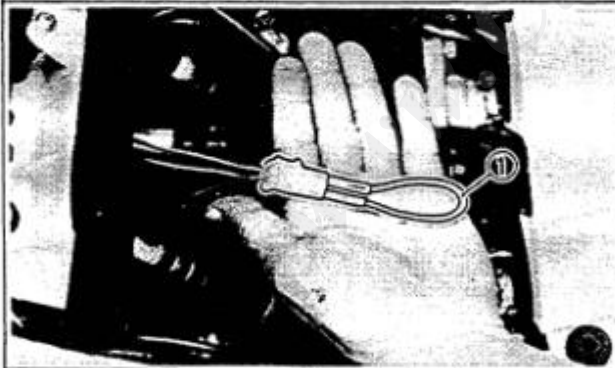

If the fan motor operates.

No

Replace the fan motor.

Yes

Replace the thermo switch.

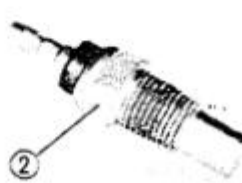
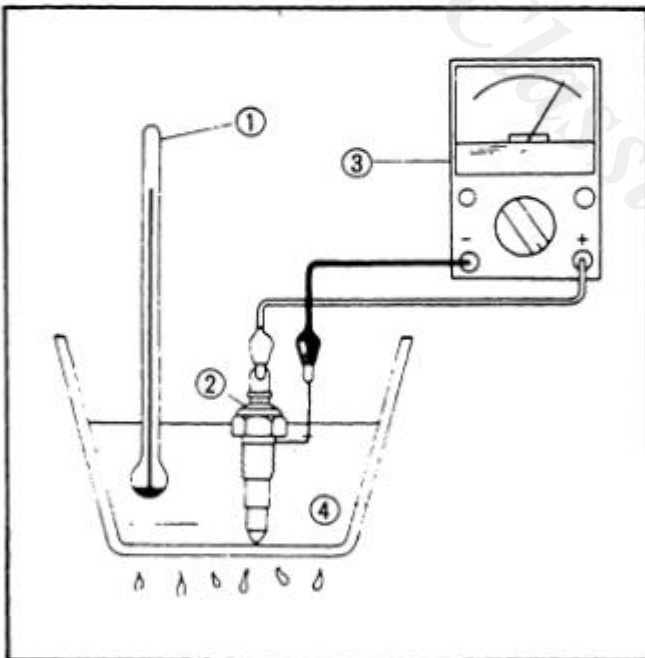
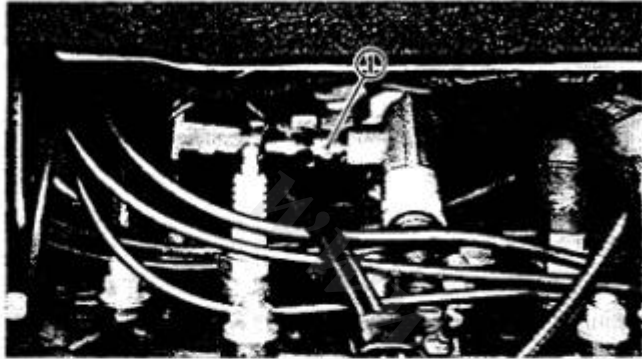
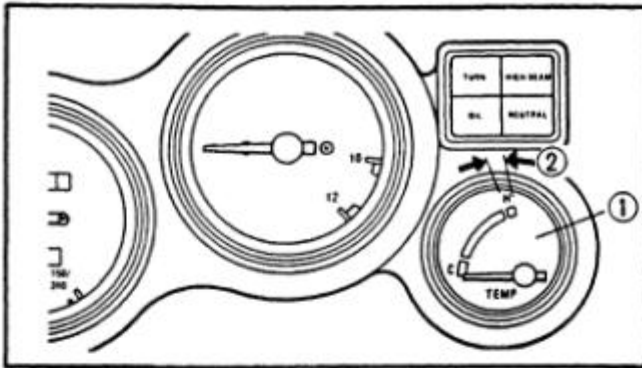

THERMO UNIT AND THERMOMETER

Operation

The thermo unit has less resistance at higher temperatures and thus allows more current to pass through. When more current flows to the coil in the temperature gauge; the armature to which the needle is attached by the increased magnetic field. In this way, the needle indicates the temperature.

- ① Temperature gauge
- ② Red zone

Thermo Unit Inspection

1. Remove:
 - Air baffle plate
 - Thermo unit ①

CAUTION:

Handle the thermo unit with special care. Never subject it to strong shock or allow it to be dropped. Should it be dropped, it must be replaced.

2. Check:
 - Thermo unit operation
 - Out of specification → Replace.

Thermo unit inspection steps:

- Immerse thermo-unit in water.
- Check continuity at indicated temperatures. Note temperatures while heating the water.

- 1 Temperature gauge
- 2 Thermo unit
- 3 Pocket Tester
- 4 Water

Water Temperature	50°C (122°F)	80°C (176°F)	100°C (212°F)
Resistance	153.9Ω	47.5 ~ 56.8Ω	26.2 ~ 29.3Ω

3. Install:
 - Thermo unit
4. Tighten:
 - Thermo unit

Thermo Unit:
15 Nm (1.5 m·kg, 11 ft·lb)



5. Install:
 - Air baffle plate

CAUTION:

After replacing the thermo unit, check the coolant level in the radiator and also check for any leakage.

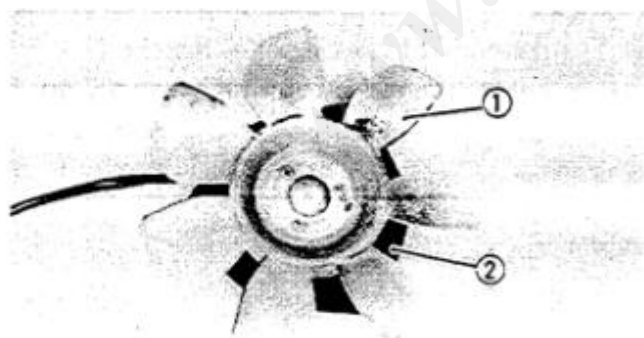
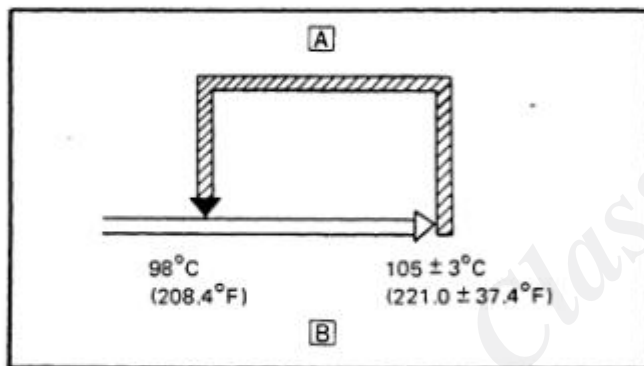

ELECTRIC FAN AND THERMO SWITCH

Operation

The electric fan will be switched ON or OFF according to the coolant temperature in the radiator.

- ① Electric fan motor

NOTE:

The electric fan is controlled by the thermo switch when the main switch is "ON". Thus, under certain operating conditions, this fan may continue to run until the engine temperature has cooled down to about 91°C (195.8°F).

- A THERMO SWITCH "ON"
- B COOLANT TEMPERATURE

Electric Fan Inspection

The following problems may require repair or replacement of components	
Component	Condition
Fan motor	Unsmooth operation Excessive vibration
Fan motor bracket	Cracks
Fan blades	
Securing bolts	Looseness

- ① Fan
- ② Electric fan motor

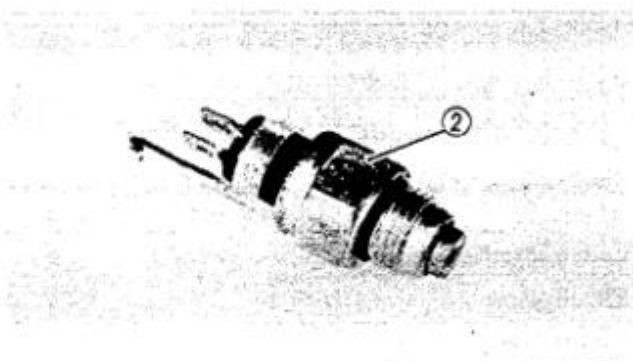
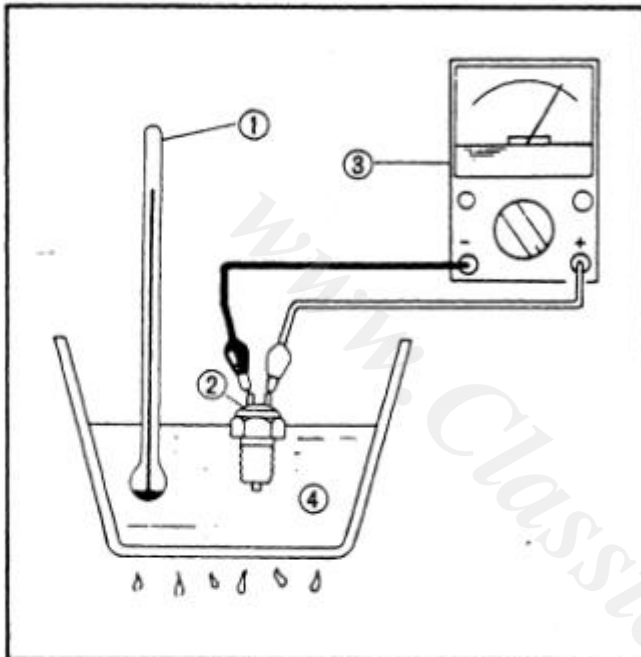
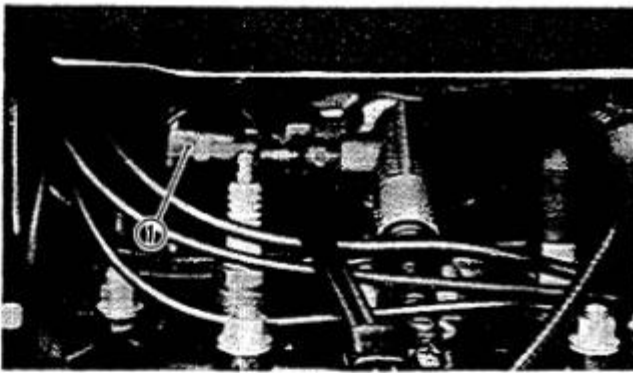

Thermo Switch Inspection

1. Remove:
 - Air baffle plate
 - Thermo switch ①

CAUTION:

Handle the thermo switch very carefully. Never subject it to strong shock or allow it to be dropped. Should it be dropped, it must be replaced.

2. Inspect:
 - Thermo switch operation

Thermo switch inspection steps:

- Immerse thermo switch in oil.
- Check continuity as indicated temperatures. Note temperatures while heating the oil.

- ① Temperature gauge
- ② Thermo switch
- ③ Pocket Tester
- ④ Oil

Test step	Oil temperature	Pocket Tester ($\Omega \times 1$)
1	0 ~ 98°C (32 ~ 208.4°F)	Discontinuity
2	more than 105° ± 3°C (more than 221.0 ± 37.4°F)	Continuity
3*	105 to 98°C (221 to 208.4°F)	Continuity
4*	less than 98°C (less than 208.4°F)	Discontinuity

Test 1 & 2; Heat-up tests
 Test 3* & 4*; Cool-down tests

3. Install:
 - Thermo switch



Thermo Switch:
 23 Nm (2.3 m·kg, 27 ft·lb)

CAUTION:

After replacing the thermo switch, check the coolant level in the radiator and also check for any leakage.

- 3. Main switch
- 4. Fuse "YPVS" (10A)
- 5. YPVS control unit
- 6. YPVS servomotor unit

- 8. CDI unit
- 41. Battery
- 42. Fuse "MAIN"

SYSTEME YPVS

Le schéma ci-dessous montre le circuit du YPVS.

- 3. Contacteur à clé
- 4. Fusible "YPVS" (10A)
- 5. Bloc de commande du YPVS
- 6. Bloc servomoteur du YPVS

- 8. Bloc CDI
- 41. Batterie
- 42. Fusible principal "MAIN" (20A)

YPVS-SYSTEM

Der nachfolgende Schaltplan zeigt den Schaltkreis des YPVS-Systems.

- 3. Hauptschalter
- 4. Sicherung "YPVS" (10A)
- 5. YPVS-Steuerereinheit
- 6. YPVS-Servomotoreinheit

- 8. CDI-Zündereinheit
- 41. Batterie
- 42. Sicherung "MAIN" (20A)

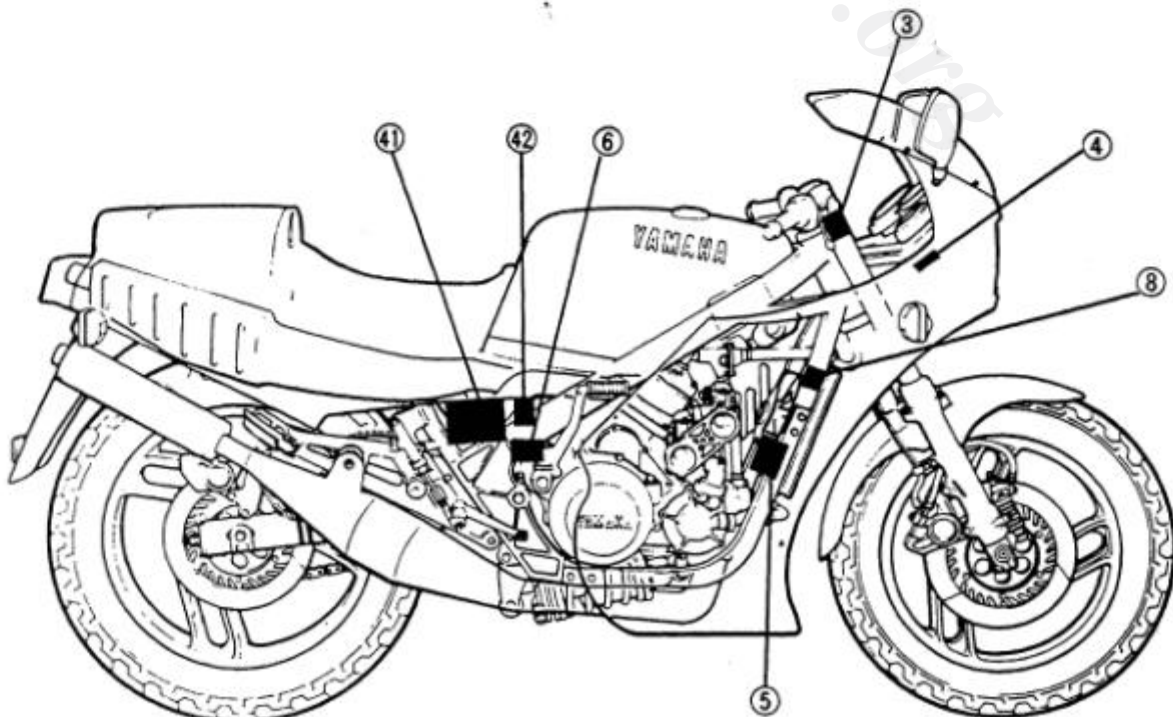



TROUBLESHOOTING CHART (1)

SERVOMOTOR DOES NOT OPERATE

Remove the rear cowling, battery, and battery box.

Disconnect the servomotor connector ① and cables.

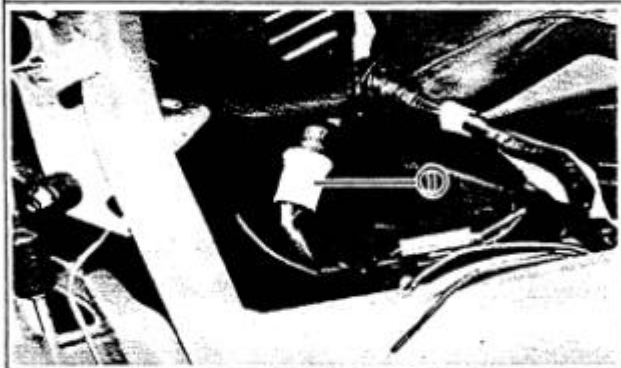

Check for the servomotor operation; use the battery ③ (12V).

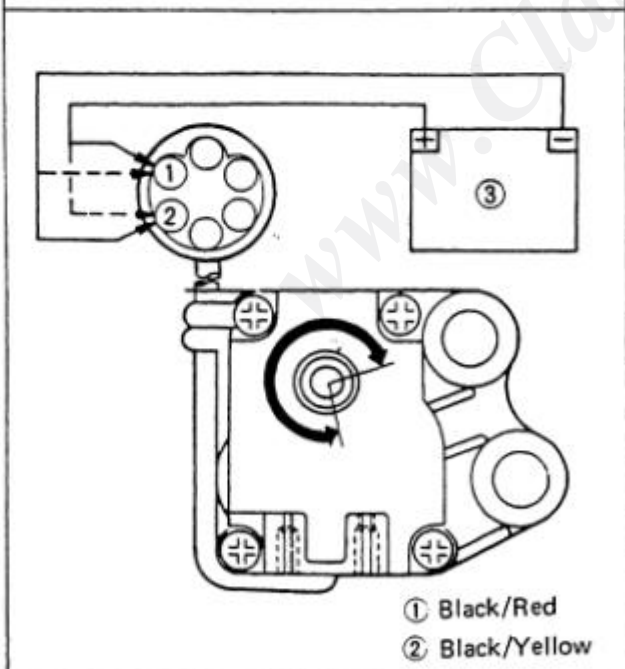

Unsmooth operation →
Replace servomotor assembly.

Servomotor connector	Battery lead	Servomotor pulley
Black/Yellow	(+)	Turn clockwise
Black/Red	(-)	
Black/Yellow	(-)	Turn counter-clockwise
Black/Red	(+)	

Check the YPVS control unit.
See "TROUBLESHOOTING CHART (2)".



TROUBLESHOOTING CHART (2)

Remove the lower and right center cowlings.

Turn the main switch to "ON".

Disconnect the YPVS control unit connector ① and check for the battery voltage (12V) on the Brown lead at the connector.

Check for an open or poor connection between the main switch and YPVS control unit connector.



Replace the YPVS control unit.

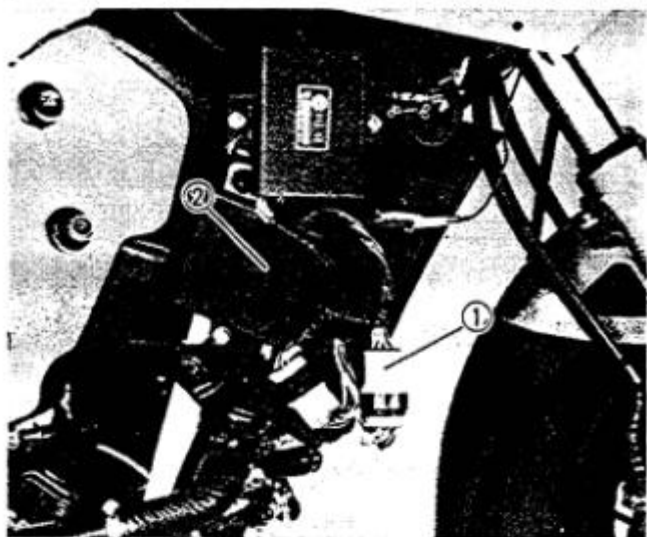

YPVS CONTROL UNIT

1. Remove:
 - Lower cowling
 - Center cowling (Right)
2. Disconnect:
 - YPVS control unit connector ①
3. Remove:
 - YPVS control unit ②
4. Install
 - YPVS control unit (New)
 - Center cowling (Right)
 - Lower cowling



YPVS SERVOMOTOR

1. Remove:
 - Rear cowling
 - Battery

NOTE:

Disconnect the negative lead first.

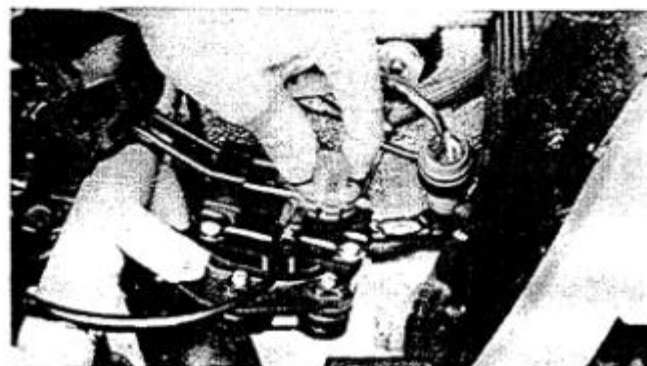

2. Disconnect:
 - YPVS cables
 - Oil pump cable
3. Remove:
 - Servomotor

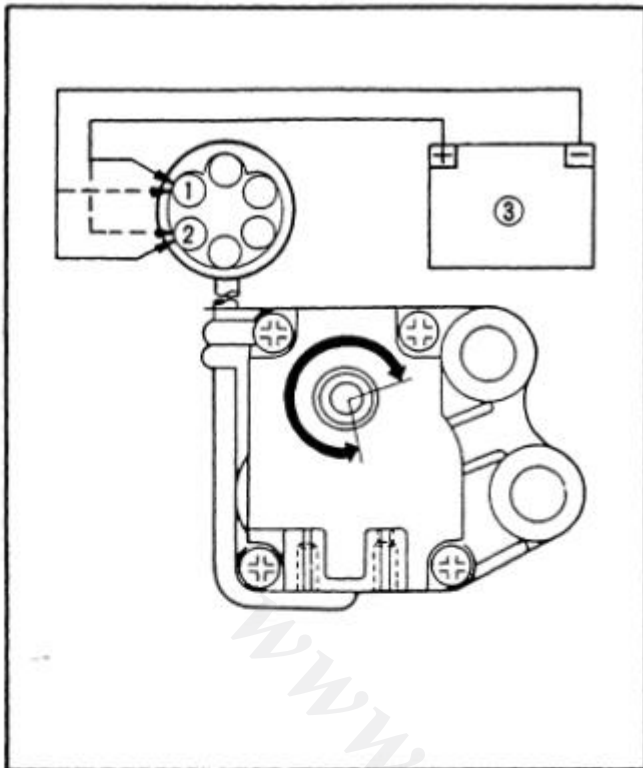

Servomotor Inspection

1. Check:
 - Servomotor operation
Use a 12V battery ③.
Unsmooth operation → Replace.

Servomotor connector	Battery lead	Servomotor pulley
Black/Yellow	(+)	Turn clockwise
Black/Red	(-)	
Black/Yellow	(-)	Turn counter-clockwise
Black/Red	(+)	

- ① Black/Red
- ② Black/Yellow

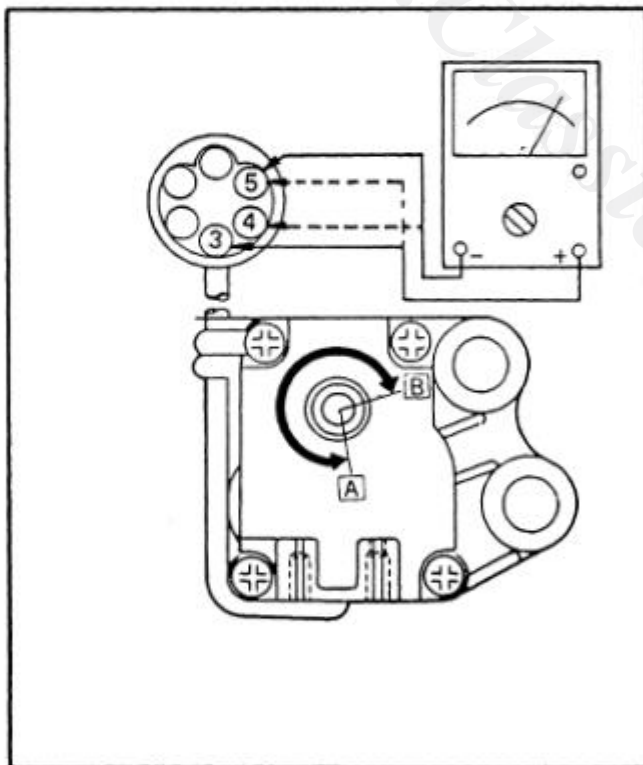

2. Measure:
 - Servomotor resistance
Use the Pocket Tester (90890-03104).
Out of specification → Replace.

 Pulley position	Servomotor connector	Resistance (at 20°C (68°F))
A	White/Black – White/Red	Less than 5Ω
	White/Red – Yellow/Blue	7.5 kΩ ± 30%
B	White/Black – White/Red	7.5 kΩ ± 30%
	White/Red – Yellow/Blue	Less than 5Ω

- ③ White/Black
- ④ Yellow/Blue
- ⑤ White/Red

CHAPTER 8. APPENDICES

SPECIFICATION	8-1
GENERAL SPECIFICATION	8-1
MAINTENANCE SPECIFICATION	8-3
GENERAL TORQUE SPECIFICATION	8-14
DEFINITION OF UNITS	8-14
LUBRICATION DIAGRAM	8-43
CABLE ROUTING	8-49
WIRING DIAGRAM	

www.ClassicCycles.org



GENERAL SPECIFICATIONS

APPENDICES

SPECIFICATIONS

GENERAL SPECIFICATIONS

(E): For England (G): For Germany (FI): For Finland

Model	RD500LC
Model Code Number:	47X
Engine Starting Number:	47X-000101
Frame Starting Number:	47X-000101
Dimensions:	
Overall Length	2,085 mm (82.1 in) Except (FI) 2,135 mm (84.1 in) (FI)
Overall Width	705 mm (27.8 in)
Overall Height	1,145 mm (45.1 in)
Seat Height	780 mm (30.7 in)
Wheelbase	1,375 mm (54.1 in)
Minimum Ground Clearance	145 mm (5.7 in)
Basic Weight	199 kg (439 lb) Except (G)
Weight Oil and Full Fuel Tank	205 kg (452 lb) (G)
Minimum Turning Radius:	3,100 mm (122 in)
Engine:	
Engine Type	Liquid cooled, 2-stroke, gasoline
Cylinder Arrangement	V-4 cylinder
Displacement	499 cm ³
Bore x Stroke	56.4 x 50.0 mm (2.22 x 1.97 in)
Compression Ratio	6.6 : 1
Compression Pressure	883 kPa (9.0 kg/cm ² , 128 psi)
Starting System	Kick starter
Lubrication System:	Separate lubrication (Yamaha Autolube)
Oil Type or Grade:	
Engine Oil	Yamaha oil 2T or equivalent Air cooled 2-stroke engine oil
Capacity	2.0 L (1.8 Imp qt, 2.1 US qt)
Transmission Oil:	
Type:	SAE 10W30 type SE motor oil
Capacity:	
Periodic Oil Change	1.5 L (1.3 Imp qt, 1.6 US qt)
Total Amount	1.6 L (1.4 Imp qt, 1.7 US qt)
Radiator Capacity:	
(Including All Routes)	1.95 L (1.72 Imp qt, 2.06 US qt)
Air Filter:	Wet type element
Fuel:	
Type	Premium gasoline
Tank Capacity	22 L (4.8 Imp gal, 5.8 US gal)
Reserve Amount	5 L (1.1 Imp gal, 1.3 US gal)
Carburetor:	
Type/Manufacturer	VM26SS x 4/MIKUNI

Model	RD500LC													
Spark Plug: Type/Manufacturer Gap	DR9HS/NGK, W27FSR/NIPPONDENSO 0.6 ~ 0.7 mm (0.024 ~ 0.028 in)													
Clutch Type:	Wet, multiple-disc													
Transmission: Primary Reduction System Primary Reduction Ratio Secondary Reduction System Secondary Reduction Ratio Transmission Type Operation Gear Ratio: 1st 2nd 3rd 4th 5th 6th	Gear 69/31 (2.225) Chain Drive 38/15 (2.533) Constant mesh, 6-speed Left foot operation 36/15 (2.400) 32/19 (1.684) 30/22 (1.363) 28/24 (1.166) 24/23 (1.043) 23/24 (0.958)													
Chassis: Frame Type Caster Angle Trail	Double cradle 26° 95 mm (3.74 in)													
Tire: Type Size (F) Size (R)	Tubeless 120/80 V16 YOKOHAMA F101/MICHELIN A48 130/80 V18 YOKOHAMA R101/MICHELIN M48													
Tire Pressure (Cold tire): Basic Weight: With Oil and Full Fuel Tank Maximum Load ✱ Cold Tire Pressure Up to 90 kg (198 lb) Load ✱ 90 kg (198 lb) ~ Maximum load ✱ High Speed Riding ✱ Load is the total weight of cargo, rider, passenger, and accessories.	<table border="1"> <tr> <td colspan="2">199 kg (439 lb), 205 kg (452) (G)</td> </tr> <tr> <td colspan="2">211 kg (465 lb), 205 kg (452) (G)</td> </tr> <tr> <td>Front</td> <td>Rear</td> </tr> <tr> <td>196 kPa (2.0 kg/cm², 28 psi)</td> <td>226 kPa (2.3 kg/cm², 32 psi)</td> </tr> <tr> <td>226 kPa (2.3 kg/cm², 32 psi)</td> <td>284 kPa (2.9 kg/cm², 42 psi)</td> </tr> <tr> <td>226 kPa (2.3 kg/cm², 36 psi)</td> <td>245 kPa (2.5 kg/cm², 36 psi)</td> </tr> </table>		199 kg (439 lb), 205 kg (452) (G)		211 kg (465 lb), 205 kg (452) (G)		Front	Rear	196 kPa (2.0 kg/cm ² , 28 psi)	226 kPa (2.3 kg/cm ² , 32 psi)	226 kPa (2.3 kg/cm ² , 32 psi)	284 kPa (2.9 kg/cm ² , 42 psi)	226 kPa (2.3 kg/cm ² , 36 psi)	245 kPa (2.5 kg/cm ² , 36 psi)
199 kg (439 lb), 205 kg (452) (G)														
211 kg (465 lb), 205 kg (452) (G)														
Front	Rear													
196 kPa (2.0 kg/cm ² , 28 psi)	226 kPa (2.3 kg/cm ² , 32 psi)													
226 kPa (2.3 kg/cm ² , 32 psi)	284 kPa (2.9 kg/cm ² , 42 psi)													
226 kPa (2.3 kg/cm ² , 36 psi)	245 kPa (2.5 kg/cm ² , 36 psi)													
Brake: Front Brake Type Operation Rear Brake Type Operation	Dual disc brake Right hand operation Single disc brake Right foot operation													
Suspension: Front Suspension Rear Suspension	Telescopic fork Swingarm (New monocross suspension)													
Shock Absorber: Front Shock Absorber Rear Shock Absorber	Coil spring, Oil damper Coil spring, Oil/Gas damper													



Model	RD500LC
Wheel Travel: Front Wheel Travel Rear Wheel Travel	140 mm (5.5 in) 120 mm (4.7 in)
Electrical: Ignition System Generator System Battery Type Model Battery Capacity	CDI A.C. generator 12N5.5-3B 12V 5.5AH
Headlight Type:	Bulb type (Quartz bulb)
Bulb Wattage x Quantity: Headlight Tail/Brake Light Flasher Light Meter Light Auxiliary Light	12V, 60W/55W x 1 12V, 5W/21W x 1 12V, 21W x 4 12V, 3.4W x 5 12V, 4W x 1 Except (E), 12V, 3.4W x 1 (E)
Indicator Light: Wattage x Quantity: "NEUTRAL" "HIGH BEAM" "TURN" "OIL"	12V, 3.4W x 1 12V, 3.4W x 1 12V, 3.4W x 1 12V, 3.4W x 1

MAINTENANCE SPECIFICATIONS

Engine

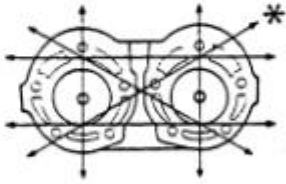
Model	RD500LC
Cylinder Head: Warp Limit 	0.05 mm (0.002 in) * Lines indicate straightedge measurement
Cylinder: Bore Size < Limit > Taper Limit Out of Round Limit	56.40 ~ 56.42 mm (2.2205 ~ 2.2213 in) 56.50 mm (2.2244 in) 0.05 mm (0.002 in) 0.05 mm (0.002 in)

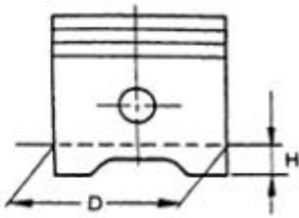
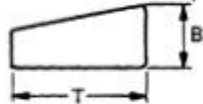
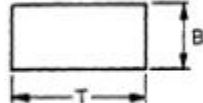
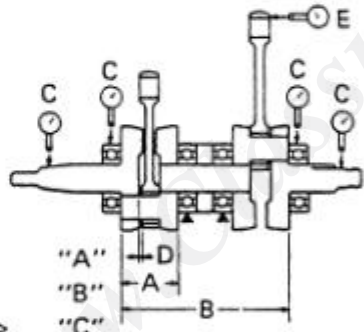
Model	RD500LC
<p>Piston: Piston Clearance < Limit > Piston Size "D" Measuring Point "H"</p>  <p>1st 2nd</p>	<p>0.060 ~ 0.065 mm (0.0024 ~ 0.0026 in) 0.10 mm (0.004 in) 56.39 ~ 56.40 mm (2.220 ~ 2.221 in) 15 mm (0.6 in)</p> <p>56.65 mm (2.230 in) 56.90 mm (2.240 in)</p>
<p>Piston Ring: Top Ring: Dimensions (B x T) End Gap (Installed) < Limit > Side Clearance (Installed) < Limit ></p>  <p>2nd Ring: Type Dimensions (B x T) End Gap (Installed) < Limit > Side Clearance (Installed) < Limit ></p> 	<p>Keystone 2.2 x 1.20 mm (0.0866 x 0.0472 in) 0.30 ~ 0.45 mm (0.012 ~ 0.018 in) 0.7 mm (0.028 in) 0.03 ~ 0.05 mm (0.0012 ~ 0.0020 in) 0.10 mm (0.0039 in)</p> <p>Plain 1.85 x 1.20 mm (0.0728 x 0.0472 in) 0.30 ~ 0.45 mm (0.012 ~ 0.018 in) 0.7 mm (0.028 in) 0.030 ~ 0.065 mm (0.0012 ~ 0.0026 in) 0.11 mm (0.0043 in)</p>
<p>Crankshaft:</p>  <p>Crack Width Assembly Width < Runout Limit > Big End Side Clearance < Limit > Small End Free Play < Limit ></p> <p>"A" "B" "C" "D" "E"</p>	<p>55.95 ~ 56.00 mm (2.2028 ~ 2.2047 in) 167.85 ~ 168.00 mm (6.6083 ~ 6.6014 in) 0.03 mm (0.0012 in) 0.25 ~ 0.75 mm (0.0098 ~ 0.00295 in) 0.1 mm (0.004 in) 0.4 ~ 0.6 mm (0.0157 ~ 0.0236 in) 2.0 mm (0.08 in)</p>
<p>Clutch: Friction Plate Thickness Quantity < Wear Limit > Clutch Plate Thickness Quantity < Warp Limit > Clutch Spring Free Length Quantity Minimum Length Ring-spring Minimum Height Push Rod Bending Limit Clutch Release Method</p>	<p>2.9 ~ 3.1 mm (0.1142 ~ 0.1220 in) 7 pcs. 2.8 mm (0.11 in) # 1 1.4 ~ 1.7 mm (0.055 ~ 0.067 in)/ # 2 2.0 mm (0.079 in) # 1 6 pcs./# 2 1 pc. 0.1 mm (0.004 in) 42.8 mm (1.69 in) 6 pcs. 41.5 mm (1.634 in) 3.25 mm (0.128 in) 0.5 mm (0.020 in) Inner push, screw push</p>



Model	RD500LC
Clutch Lever: Free Play	8 ~ 12 mm (0.31 ~ 0.47 in)
Balancer: Drive Method	Gear
Transmission: Main Axle Deflection Limit Drive Axle Deflection Limit	0.08 mm (0.0031 in) 0.08 mm (0.0031 in)
Shifter: Shifter Type Guide Bar Bending Limit	Guide Bar 0.1 mm (0.024 in)
Carburetor: I.D. Mark Main Jet (M.J.) Main Air Jet (M.A.J.) Jet Needle (J.N.) Needle Jet (N.J.) Pilot Air Jet (P.A.J.) Pilot Jet (P.J.) Valve Seat Size (V.S.) Starter Jet (G.S.) Fuel Level (F.L.) Float Height (F.H.) Engine Idle Speed	47X00 = 195 = 1.8 (Upper cylinder), = 1.6 (Lower cylinder) 5LT14-3 0-0 = 1.1 = 22.5 2.8 = 40 1.5 ± 1.0 mm (0.06 ± 0.04 in) 21 ± 1.0 mm (0.83 ± 0.04 in) 1,250 r/min
Reed Valve: Valve Stopper Height Valve Bending Limit	8.7 ~ 9.3 mm (0.343 ~ 0.366 in) 0.5 mm (0.02 in)
Lubrication System: Oil Filter Type: Oil Pump Type: Tip clearance < Limit > Side Clearance < Limit >	Paper type Trochoid type 0.10 ~ 0.15 mm (0.004 ~ 0.006 in) 0.17 mm (0.0067 in) 0.04 ~ 0.09 mm (0.0016 ~ 0.0035 in) 0.12 mm (0.0047 in)

Lubrication Chart:

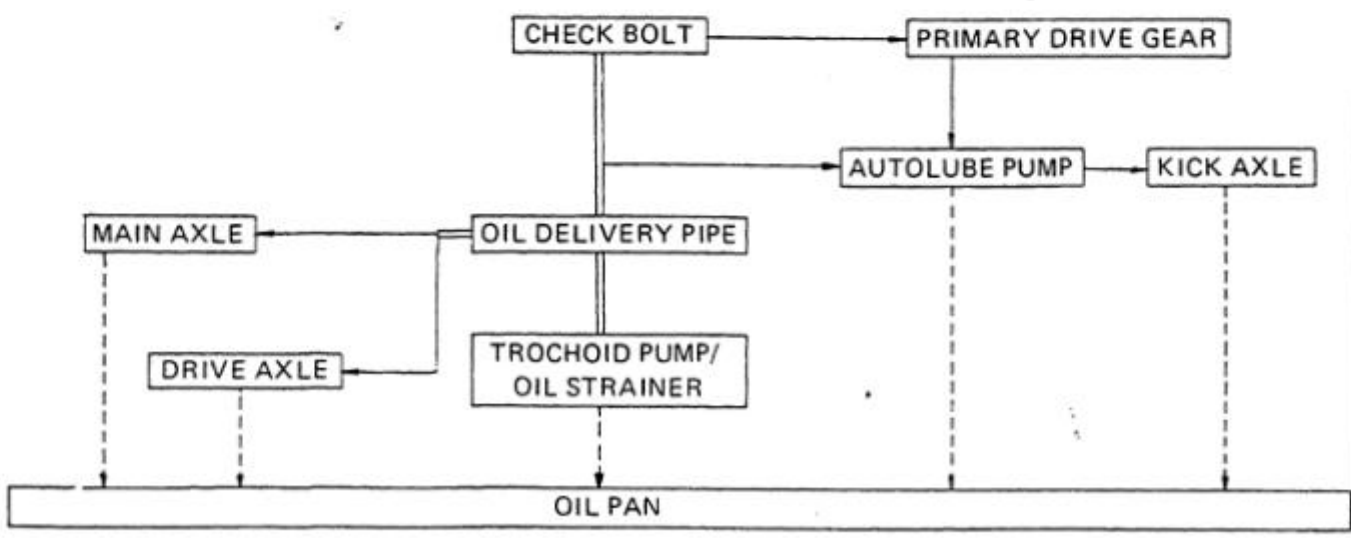





Model	RD500LC
<p>Cooling System:</p> <p>Radiator Core Size: Width Height Thickness</p> <p>Radiator Cap Opening Pressure</p> <p>Coolant:</p> <p>Total Amount</p> <p>Reservoir Tank Capacity < From Low to Full Level ></p> <p>Water Pump</p> <p> Type</p> <p> Reduction Ratio</p>	<p>315 mm (12.4 in)</p> <p>220 mm (8.66 in)</p> <p>16 mm (0.63 in)</p> <p>78 ~ 98 kPa (0.8 ~ 1.0 kg/cm², 11.4 ~ 14.2 psi)</p> <p>1.95 L (1.72 Imp qt, 2.06 US qt)</p> <p>0.35 L (0.31 Imp qt, 0.37 US qt)</p> <p>0.25 L (0.22 Imp qt, 0.264 US qt)</p> <p>Single-suction centrifugal pump</p> <p>28/18 (1.555)</p>
<p>Thermostat:</p> <p>Opening Temperature</p> <p>Full Open Temperature/Lift</p>	<p>65°C (149°F)</p> <p>80°C (176°F)/7 mm (0.28 in) or more</p>

www.ClassicCycles.org



Tightening Torque

Part to be tightened	Part name	Thread size	Q'ty	Tightening torque			Remarks
				Nm	m·kg	ft·lb	
Cylinder head	Nut	M8 x 1.25	20	22	2.2	16	
Spark plug	—	M14 x 1.25	4	20	2.0	14	
Cylinder	Stud bolt	M8 x 1.25	20	13	1.3	9.4	
Crankcase	Stud bolt	M8 x 1.25	16	13	1.3	9.4	
Cylinder	Nut	M8 x 1.25	16	28	2.8	20	
Coolant drain (Cyl. Head)	Flange bolt	M8 x 1.25	1	16	1.6	11	
YPVS valve	Bolt	M5 x 0.8	4	7	0.7	5.1	
YPVS holder	Bolt	M6 x 1.0	4	7	0.7	5.1	
YPVS holder retainer	Bolt	M5 x 0.8	4	7	0.7	5.1	
YPVS joint holder	Bolt	M5 x 0.8	4	7	0.7	5.1	
YPVS pulley bracket	Bolt	M6 x 1.0	2	10	1.0	7.2	
YPVS pulley	Screw	M5 x 0.8	2	5	0.5	3.6	
Coolant drain (Water pump)	Flange bolt	M8 x 1.25	1	16	1.6	11	
Water pump housing	Bolt	M6 x 1.0	5	10	1.0	7.2	
Water jacket	Bolt	M6 x 1.0	4	10	1.0	7.2	
Thermostat cover	Bolt	M6 x 1.0	3	10	1.0	7.2	
Thermostat housing-Bracket	Bolt	M6 x 1.0	1	10	1.0	7.2	
Thermostat housing-Cylinder	Bolt	M6 x 1.0	1	8	0.8	5.8	
Radiator mount	Bolt	M6 x 1.0	4	7	0.7	5.1	
Oil pump (Engine oil)	Bolt	M6 x 1.0	2	10	1.0	7.2	
Oil pump (Transmission oil)	Screw	M5 x 0.8	2	5	0.5	3.6	
Oil pum housing	Bolt/Screw	M6 x 1.0	3	8	0.8	5.8	
Drain plug	Bolt	M12 x 1.25	1	22	2.2	16	
Delivery pipe-Cover	Bolt	M6 x 1.25	2	10	1.0	7.2	
Delivery pipe	Union bolt	M8 x 1.25	2	17.5	1.75	12.5	
Carburetor joint	Bolt	M6 x 1.0	16	10	1.0	7.2	
Exhaust pipe flange	Stud bolt	M8 x 1.25	6	13	1.3	9.4	
Exhaust pipe	Nut	M8 x 1.25	6	22	2.2	16	
Exhaust pipe	Flange bolt	M8 x 1.25	2	22	2.2	16	
Muffler (Upper)	Flange bolt	M8 x 1.25	4	16	1.6	11	
Bearing retainer (Main axle)	Bolt	M6 x 1.0	2	10	1.0	7.2	
Oil buffer	Bolt	M6 x 1.0	1	10	1.0	7.2	
Crankcase	Bolt	M8 x 1.25	17	24	2.4	17	
Crankcase	Stud bolt	M8 x 1.25	1	13	1.3	9.4	
Crankcase	Nut	M8 x 1.25	1	22	2.2	16	
Bearing retainer (Drive axle)	Bolt	M6 x 1.0	2	7	0.7	5.1	
Transmission cover	Bolt	M6 x 1.0	8	10	1.0	7.2	
Generator cover housing	Bolt	M6 x 1.0	3	10	1.0	7.2	
Generator cover	Bolt	M6 x 1.0	3	10	1.0	7.2	
Crankcase cover (Left)	Bolt	M6 x 1.0	6	10	1.0	7.2	
Crankcase cover (Right)	Bolt	M6 x 1.0	11	10	1.0	7.2	
Crankcase blind plug retainer	Bolt	M6 x 1.0	1	10	1.0	7.2	
Shift cam stopper	Bolt	M6 x 1.0	1	10	1.0	7.2	
Kick gear stopper	Bolt	M6 x 1.0	2	10	1.0	7.2	Use lock washer

Part to be tightened	Part name	Thread size	Q'ty	Tightening torque			Remarks
				Nm	m·kg	ft·lb	
Kick crank	Nut	M12 x 1.5	1	65	6.5	47	
Primary gear	Nut	M16 x 1.5	2	85	8.5	61	
Clutch boss	Nut	M20 x 1.5	1	90	9.0	65	Use lock washer
Clutch cam housing	Screw	M5 x 0.8	2	5	0.5	3.6	
Pressure plate	Screw	M6 x 1.0	6	8	0.8	5.8	
Clutch adjuster lock	Nut	M8 x 1.25	1	16	1.6	11	
Drive sprocket	Nut	M22 x 1.5	1	90	9.0	65	Use lock washer
Shift arm	Bolt	M6 x 1.0	1	10	1.0	7.2	
Change pedal adjuster	Nut	M6 x 1.0	2	8	0.8	5.8	
Thermo switch	-	M16 x 1.25	1	23	2.3	17	
Thermo unit	-	-	1	15	1.5	11	
Neutral switch	-	M10 x 1.25	1	3	0.3	2.2	
Stator coil	Screw	M6 x 1.0	3	7	0.7	5.1	
Flywheel	Nut	M12 x 1.5	1	80	8.0	58	
Pickup coil	Screw	M5 x 0.8	2	5	0.5	3.6	

www.ClassicCycles.org



Chassis

Model	RD500LC
Steering System: Steering Bearing Type	Taper roller bearing
Front Suspension: Front Fork Travel Fork Spring Free Length < Limit > Collar Length Spring Rate K1 K2 K3 Stroke K1 K2 K3 Optional Spring Oil Capacity Oil Grade	140 mm (5.51 in) 498 mm (19.6 in) 493 mm (19.4 in) 40 mm (1.57 in) 7.75 N/mm (0.79 kg/mm, 44.2 lb/in) 10.20 N/mm (1.04 kg/mm, 58.2 lb/in) 24.00 N/mm (2.45 kg/mm, 137 lb/in) 0 ~ 95 mm (0 ~ 3.74 in) 95 ~ 115 mm (3.74 ~ 4.53 in) 115 ~ 140 mm (4.53 ~ 5.51 in) No. 300 cm ³ (10.6 Imp oz, 10.1 US oz) SAE 5W type SE motor oil or equivalent
Rear Suspension: Shock Absorber Travel Spring Free Length < Limit > Fitting Length Spring Rate Stroke Optional Spring Enclosed Gas Pressure	40 mm (1.57 in) 168.5 mm (6.63 in) 167 mm (6.57 in) 159 mm (6.26 in) 157 N/mm (16.0 kg/mm, 896 lb/in) 40 mm (1.57 in) No. 981 kPa (10 kg/cm ² , 142 psi)
Rear Arm: Swingarm Free Play Limit: End Swingarm Free Play Limit: Side	1 mm (0.04 in) 1 mm (0.04 in)
Front Wheel: Type Rim Size Rim Material Rim Runout Limit Radial Lateral	Cast wheel MT2.75 x 16 Aluminum 2 mm (0.08 in) 2 mm (0.08 in)
Rear Wheel: Type Rim Size Rim Material Rim Runout Limit Radial Lateral	Cast wheel MT3.00 x 18 Aluminum 2 mm (0.08 in) 2 mm (0.08 in)
Drive chain: Type/Manufacturer No. of Links Chain Slack	50VR/DID 102 Links 15 ~ 20 mm (0.6 ~ 0.8 in)

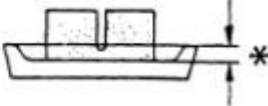
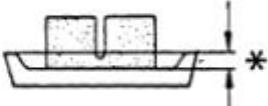

Model	RD500LC
<p>Front Disc Brake:</p> <p>Type Disc Outside Dia. x Thickness Wear Limit Pad Thickness Inner < Limit > * Pad Thickness Out < Limit > *</p>  <p>Master Cylinder Inside Dia. Caliper Cylinder Inside Dia. Brake Fluid Type</p>	<p>Dual 267 x 7.5 mm (10.5 x 0.295 in) 7 mm (0.28 in) 5.5 mm (0.217 in) 0.5 mm (0.02 in) 5.5 mm (0.217 in) 0.5 mm (0.02 in)</p> <p>15.87 mm (0.63 in) 42.85 mm (1.69 in) DOT # 3</p>
<p>Rear Disc Brake:</p> <p>Type Disc Outside Dia. x Thickness Wear Limit Pad Thickness Inner < Limit > * Pad Thickness Outer < Limit > *</p>  <p>Master Cylinder Inside Dia. Caliper Cylinder Inside Dia. Brake Fluid Type</p>	<p>Single 245 x 8.5 mm (0.65 x 0.34 in) 8 mm (0.31 in) 5.5 mm (0.217 in) 0.5 mm (0.02 in) 5.5 mm (0.217 in) 0.5 mm (0.02 in)</p> <p>12.70 mm (0.50 in) 38.18 mm (1.50 in) DOT # 3</p>
<p>Brake Lever and Brake Pedal:</p> <p>Brake Lever Free Play Brake Pedal Position Brake Pedal Free Play</p>	<p>1 ~ 2 mm (0.04 ~ 0.08 in) 50 ~ 60 mm (2.0 ~ 2.4 in) (Below the top of the footrest) 20 ~ 30 mm (0.8 ~ 1.2 in)</p>



Tightening Torque

Part to be tightened	Part name	Thread size	Q'ty	Tightening torque			Remarks
				Nm	m·kg	ft·lb	
Front axle	Bolt	M14 x 1.5	1	58	5.8	42	
Rear axle	Bolt/Nut	M16 x 1.5	1	105	10.5	75	
Rear axle lock	Nut	M16 x 1.5	1	60	6.0	43	
Front axle pinch	Bolt/Nut	M8 x 1.25	1	20	2.0	14	
Steering crown-Fork	Bolt	M8 x 1.25	2	20	2.0	14	
Steering stem	Nut	M25 x 1.0	1	110	11	80	
Under bracket-Fork	Bolt/Nut	M8 x 1.25	4	23	2.3	17	
Caliper	Bolt	M10 x 1.25	6	35	3.5	25	
Air bleed (All)	Screw	M8 x 1.25	6	6	0.6	4.3	
Brake hose (All)	Union bolt	M10 x 1.25	9	26	2.6	19	
Front master cylinder bracket	Bolt	M6 x 1.0	2	9	0.9	6.5	
Front master cylinder cap	Screw	M5 x 0.8	2	2	0.2	1.4	
Brake disc	Bolt	M8 x 1.25	18	20	2.0	14	
Driven sprocket	Bolt/Nut	M8 x 1.25	6	32	3.2	23	
Handlebar-Fork	Bolt	M8 x 1.25	4	20	2.0	14	
Handlebar-Steering crown	Bolt	M6 x 1.0	2	9	0.9	6.5	
Engine mount (Front lower)	Bolt/Nut	M8 x 1.25	1	32	3.2	23	
Engine mount (Rear upper)	Bolt/Nut	M8 x 1.25	1	32	3.2	23	
Engine mount (Rear lower)	Bolt	M8 x 1.25	1	32	3.2	23	
Pivot shaft	Bolt	M16 x 1.25	1	85	8.5	81	
Relay arm 1-Frame	Bolt/Cap nut	M10 x 1.25	1	32	3.2	23	
Relay arm 1-Relay arm 2	Bolt/Nut	M10 x 1.25	1	32	3.2	23	
Swingarm-Relay arm 2	Bolt/Nut	M10 x 1.25	1	32	3.2	23	
Shock absorber-Relay arm 2	Bolt/Nut	M10 x 1.25	1	32	3.2	23	
Tensionbar-Frame (Left)	Bolt	M10 x 1.25	1	32	3.2	23	
Tensionbar-Frame (Right)	Bolt/Nut	M8 x 1.25	1	32	3.2	23	
Tensionbar-Engine	Bolt/Nut	M8 x 1.25	1	23	2.3	17	
Tensionbar-Shock absorber	Bolt/Nut	M10 x 1.25	1	32	3.2	23	
Footrest-Muffler bracket	Bolt/Nut	M10 x 1.25	4	42	4.2	30	
Rear master cylinder-Bracket	Bolt/Nut	M8 x 1.25	2	20	2.0	14	
Muffler-Bracket	Bolt/Nut	M10 x 1.25	2	25	2.5	18	
Down tube frame	Bolt/Nut	M8 x 1.25	3	32	3.2	23	

Electrical

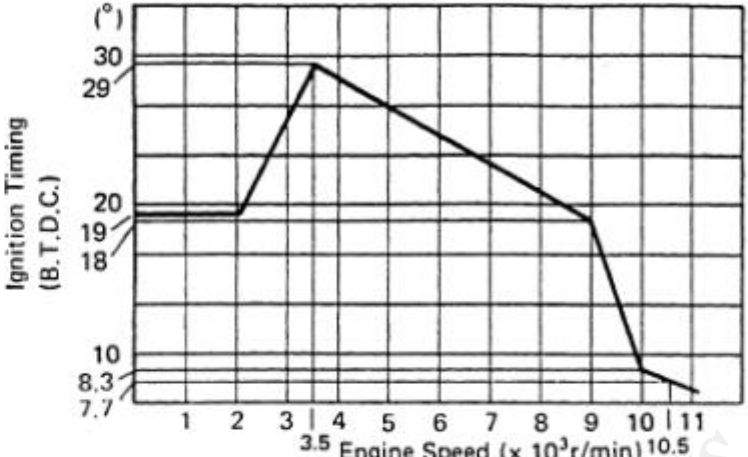
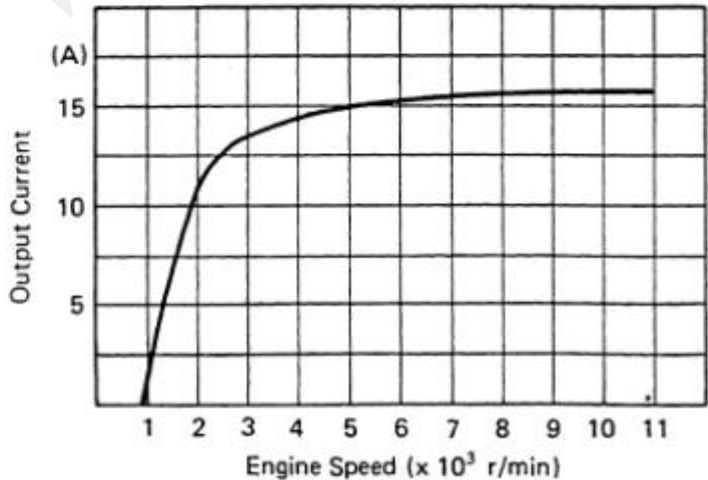
Model	RD500LC
<p>Voltage:</p> <p>Ignition System:</p> <p>Ignition Timing (B.T.D.C.)</p> <p>Advanced Timing (B.T.D.C.)</p> <p>Advancer Type</p>	<p>12V</p> <p>19° at 1,200 r/min</p> <p>7° at 11,000 r/min</p> <p>Electrical</p> 
<p>CDI:</p> <p>CDI Unit-Model/Manufacturer</p> <p>Pickup Coil Resistance (Color)</p> <p>Source Coil Resistance (Color)</p>	<p>47X-50/NIPPONDENSO</p> <p>112Ω ± 20% at 20°C (68°F) (White/Green – White/Red)</p> <p>127Ω ± 20% at 20°C (68°F), 18.8Ω ± 20% at 20°C (68°F) (Green – Brown), (Brown – Red)</p>
<p>Ignition Coil:</p> <p>Model/Manufacturer</p> <p>Primary Winding Resistance</p> <p>Secondary Winding Resistance</p>	<p>47X-50/NIPPONDENSO</p> <p>0.67Ω ± 20% at 20°C (68°F)</p> <p>12 kΩ ± 20% at 20°C (68°F)</p>
<p>Spark Plug Cap:</p> <p>Type</p> <p>Resistance</p>	<p>Noise-Suppressor type</p> <p>5 kΩ</p>
<p>Charging System/Type:</p>	<p>A.C. generator</p>
<p>A.C. Generator:</p> <p>Model/Manufacturer</p> <p>Nominal Output</p>	<p>47X50/NIPPONDENSO</p> <p>14V, 14A at 3,000 r/min</p>  <p>Stator Coil Winding Resistance (Color)</p>
<p>0.4Ω ± 20% at 20°C (68°F) (White – White)</p>	



Model	RD500LC
Voltage Regulator: Type Model/Manufacturer No. Load Regulated Voltage	Short circuit SH569/SHINDENGEN 14.3 ~ 15.3V
Rectifier: Model/Manufacturer Capacity Withstand Voltage	SH569/SHINDENGEN 25A 200V
Battery: Capacity Specific Gravity	12V, 5.5AH 1.280
Horn: Type x Quantity Model/Manufacturer Maximum Amperage	Plain type x 1 CF-12/NIKKO 2.5A
Flasher Relay: Type Model/Manufacturer Self Cancelling Device Flasher Frequency Wattage	Condenser type 4K0/NIPPONDENSO Yes. Except (G). NO (G) 85 cycle/min 21W x 2 + 3.4W
Self Cancelling Unit: Except (G) Model/Manufacturer	1A0/MATSUSHITA
Oil Level Switch: Model/Manufacturer	47X/TAIHEIYO ASTI
Electric Fan: Model/Manufacturer Operating Temperature	47X/NIPPONDENSO 105 ~ 98°C (221 ~ 208°F)
Thermostatic Switch: Model/Manufacturer	47X/NIHON THERMOSTAT
Thermo-Unit: Model/Manufacturer	11H/NIPPONSEIKI
Circuit Breaker: Type Amperage for Individual Circuit/Quantity Main Headlight YPVS Signal Reserve	Fuse 20A x 1 15A x 1 10A x 1 10A x 1 15A x 1

GENERAL TORQUE SPECIFICATIONS

This chart specifies torque for standard fasteners with standard I.S.O. pitch threads. Torque specifications for special components or assemblies are included in the applicable sections of this book. To avoid warpage, tighten multifastener assemblies in a crisscross fashion, in progressive stages, until full torque is reached. Unless otherwise specified, torque specifications call for clean, dry threads. Components should be at room temperature.

A (Nut)	B (Bolt)	General torque specifications		
		Nm	m·kg	ft·lb
10 mm	6 mm	6	0.6	4.3
12 mm	8 mm	15	1.5	11
14 mm	10 mm	30	3.0	22
17 mm	12 mm	55	5.5	40
19 mm	14 mm	85	8.5	61
22 mm	16 mm	130	13.0	94

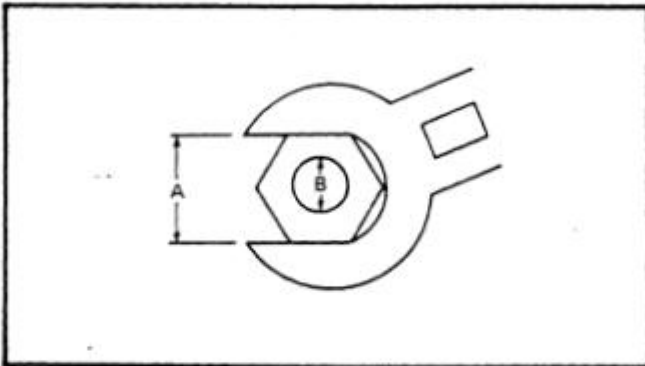

DEFINITION OF UNITS

Unit	Read	Definition	Measure
mm	millimeter	10^{-3} meter	Length
cm	centimeter	10^{-2} meter	Length
kg	kilogram	10^3 gram	Weight
N	Newton	$1 \text{ kg} \times \text{m}/\text{sec}^2$	Force
Nm	Newton meter	$\text{N} \times \text{m}$	Torque
m·kg	Meter kilogram	$\text{m} \times \text{kg}$	Torque
Pa	Pascal	N/m^2	Pressure
N/mm	Newton per millimeter	N/mm	Spring rate
L	Liter	—	Volume or Capacity
cm^3	Cubic centimeter	—	Volume or Capacity
r/min	Rotation per minute	—	Engine speed

LUBRICATION DIAGRAM (1)

1. Delivery pipe
2. Oil pump (Engine oil)
3. Kick axle
4. Crankshaft (Upper)
5. Main axle
6. Oil pump drive shaft
7. Oil pump (Transmission oil)

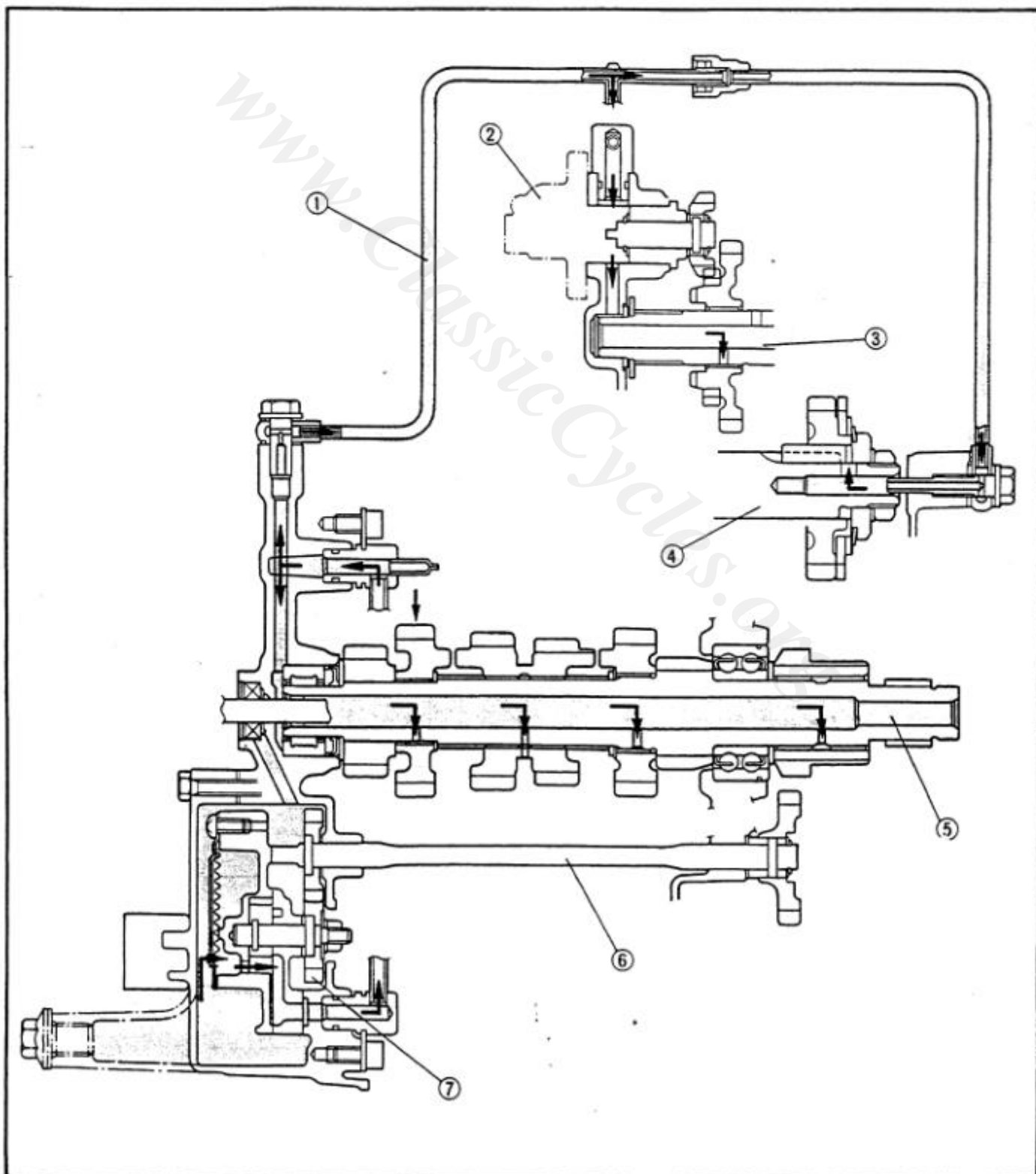



LUBRICATION DIAGRAM (2)

1. Delivery pipe
2. O-ring
3. Oil pump (Engine oil) drive gear
4. Kick gear
5. Oil pump (Transmission oil) drive gear
6. Oil pump idle gear

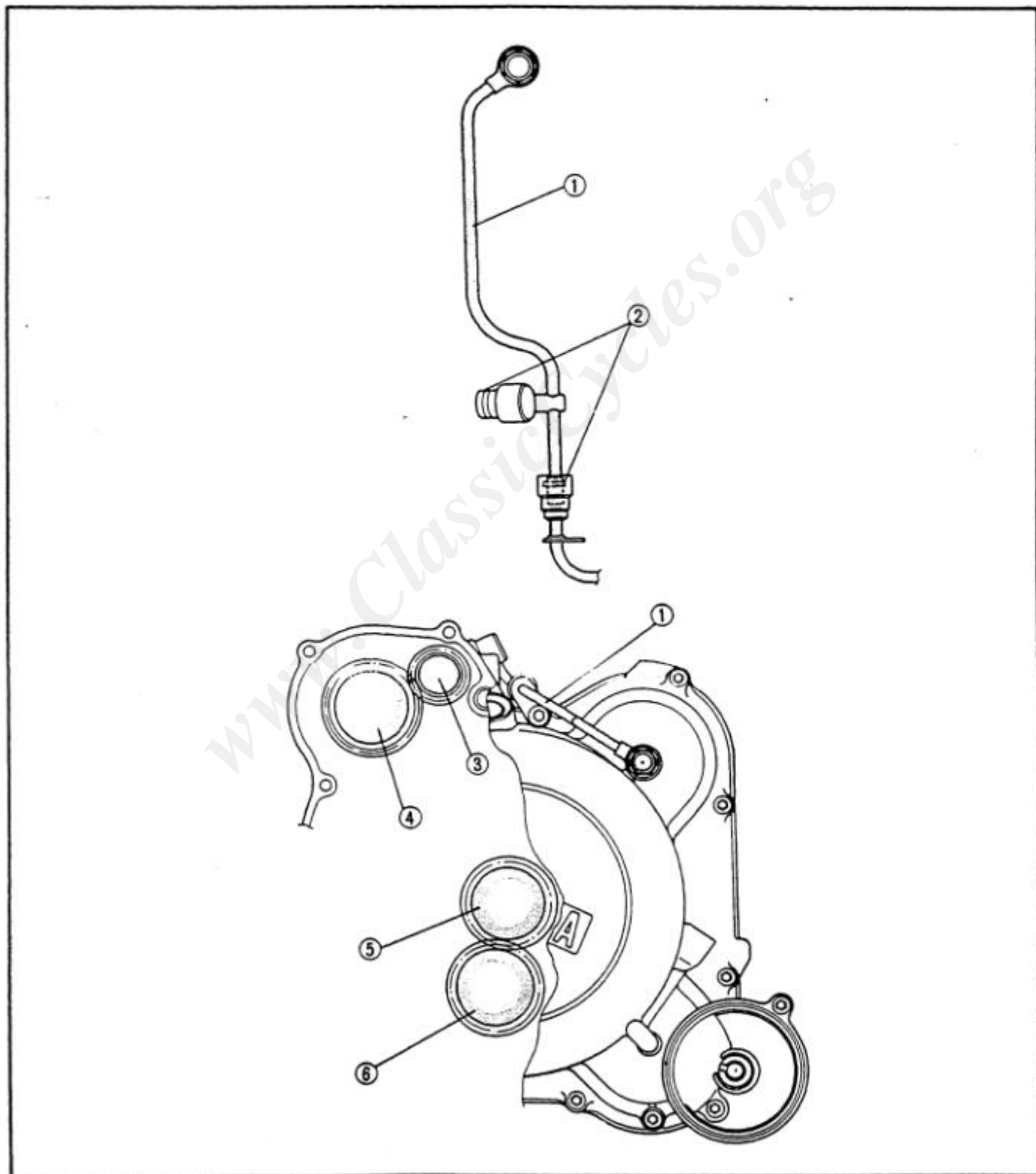



LUBRICATION DIAGRAM (3)

1. Delivery pipe
2. Drive axle
3. Main axle
4. Oil pump (Transmission oil)

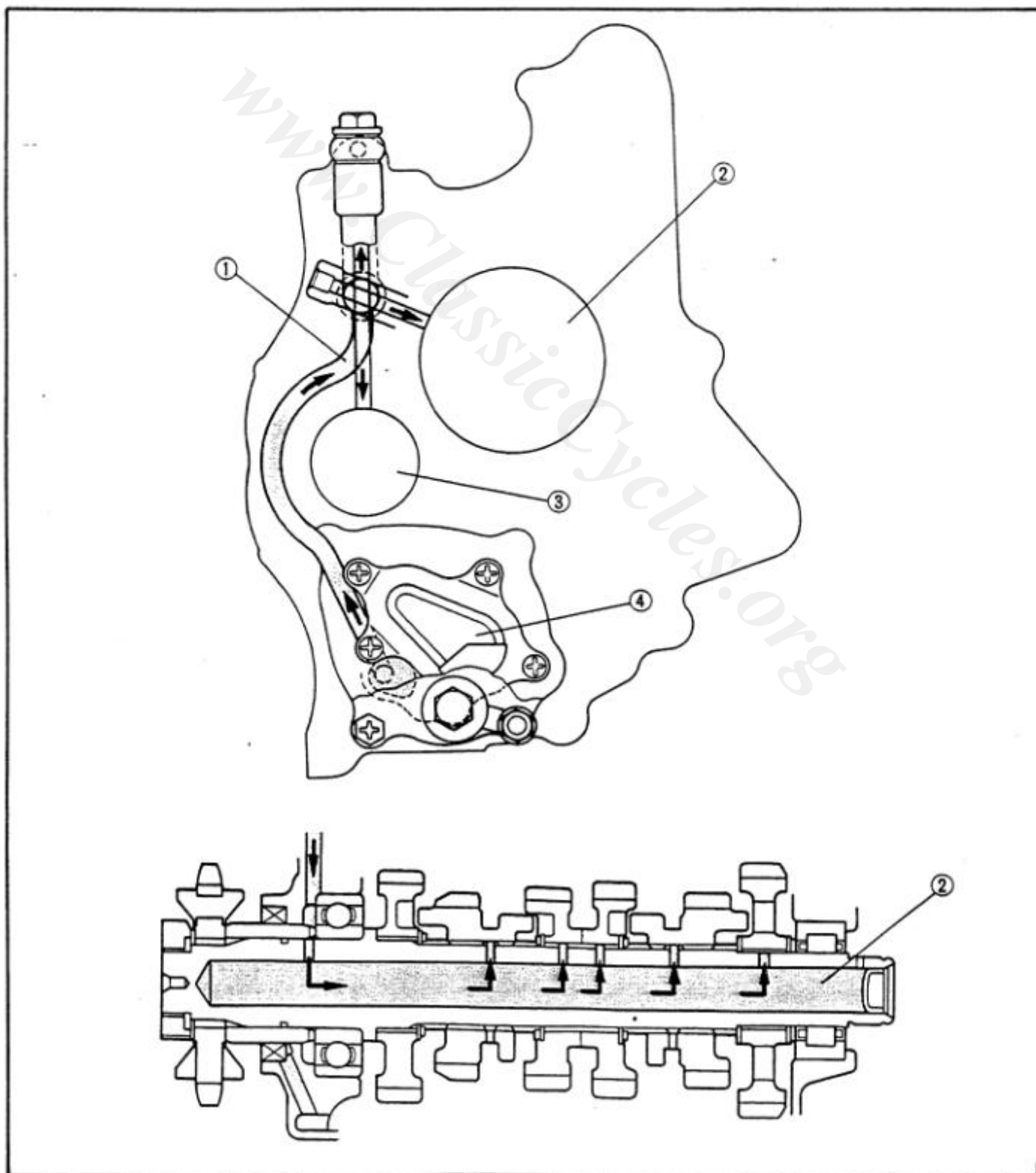



CABLE ROUTING (1)

1. Flasher canceling unit
(Except for Germany)
2. Pass the horn lead under the cowling stay
3. Main switch
4. Clamp
5. To fuse
6. To sub lead
7. Pass the handlebar switch lead (Right) between the front fork (Right) and head pipe.
8. Handlebar switch lead (Right)
9. Clutch cable
10. Pass the clutch cable between the tank rail and main frame support.
11. Clamp the wireharness only.
12. To carburetor
13. Connect the fuel hose with the white mark to the "ON" side (Lower) of the fuel cock.
14. Connect the fuel hose without the white mark to the "RES" side (Upper) of the fuel cock.
15. Pass the lead under the main frame support.
16. To regulator and ignition coil
17. To oil tank
18. Handlebar switch lead (Left)
19. Pass the throttle cable between tank rail and main frame support.
20. To horn
21. To meter

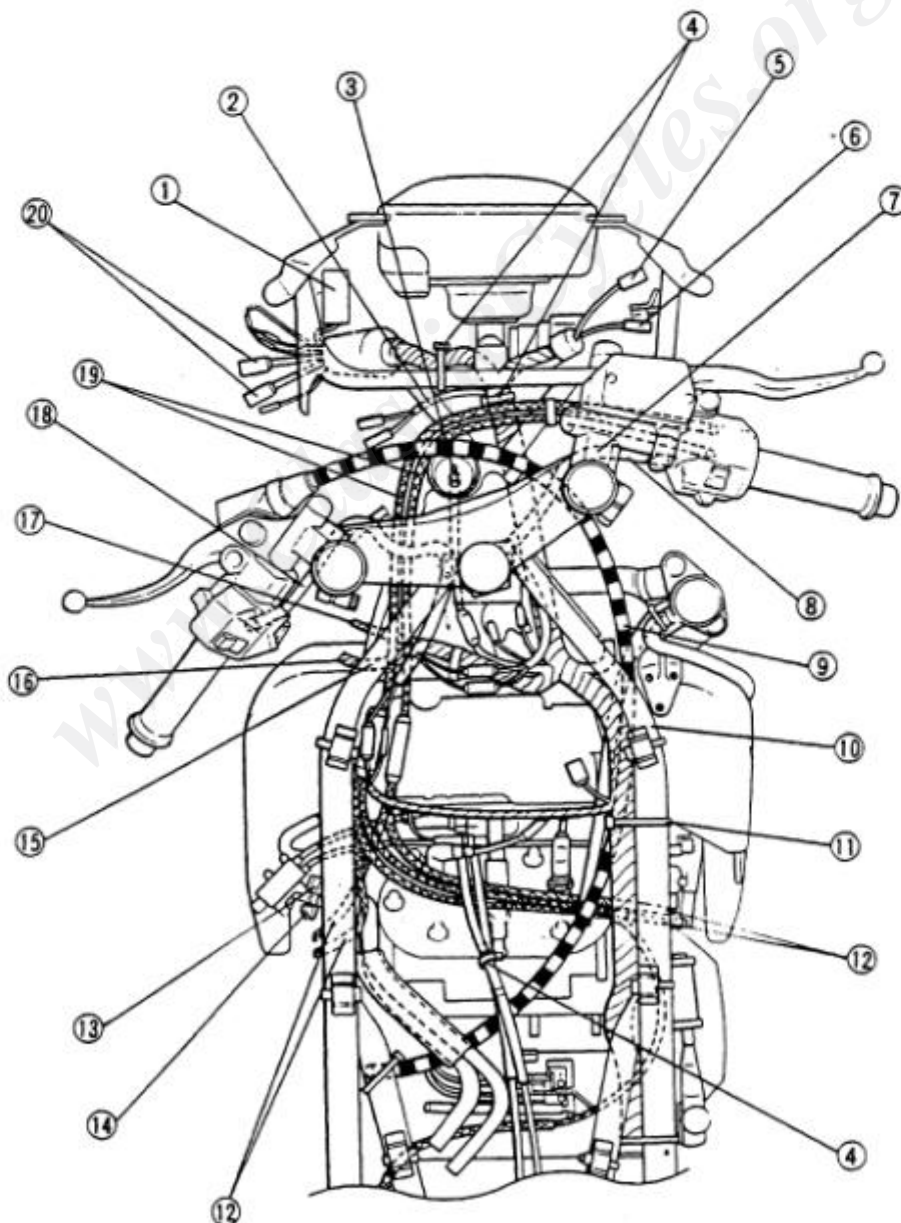

CABLE ROUTING (2)

- | | |
|---|---|
| <ol style="list-style-type: none"> 1. Front flasher light lead (Left) 2. To speedometer 3. Handle switch lead (Left) 4. To oil level gauge 5. ON 6. RES 7. Fuel cock 8. To oil pump 9. Clutch cable 10. Battery 11. Pass the wireharness behind the radiator, then if front of the air cleaner and to the fan motor. | <ol style="list-style-type: none"> 12. To AC magneto and generator assembly 13. Ignition coil 14. Rectifier/Regulator 15. To oil tank 16. Speedometer cable 17. Pass the brake hose behind the front fork. 18. Front brake hose 19. Front brake hose (Right) 20. Front brake hose (Left) |
|---|---|

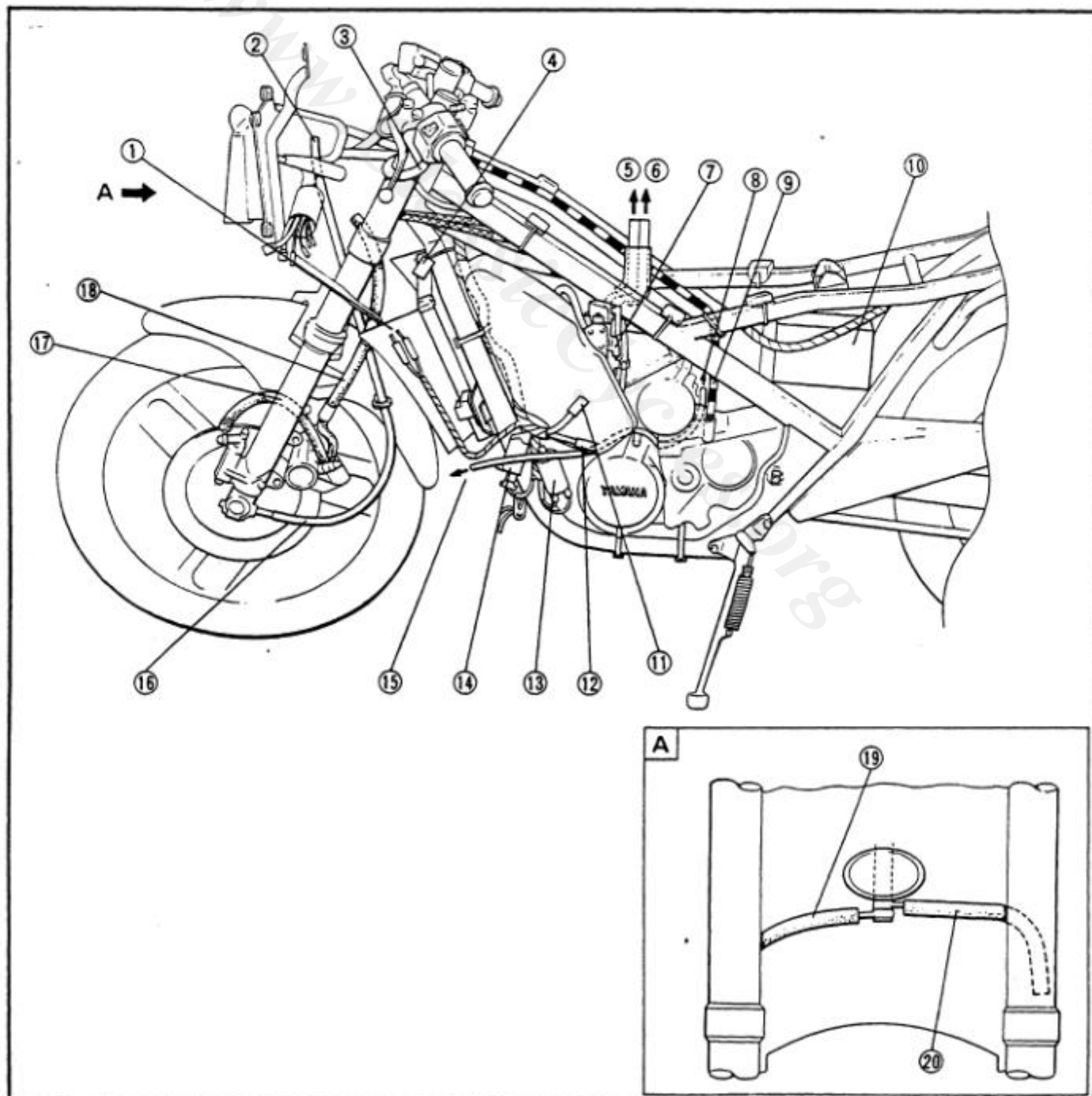



CABLE ROUTING (3)

1. YPVS servo motor
2. Clamp
3. Pass the wireharness between the tool box and bracket.
4. Pass the rear flasher lead (Right) through the bracket hole.
5. Taillight lead
6. Pass the rear flasher lead (Left) through the bracket hole.
7. Pass the wireharness under the frame.
8. Connect the fuel hose without the white mark to the "RES" side of the fuel tank.
9. Connect the fuel hose with the white mark to the "ON" side of the fuel tank.
10. To oil tank

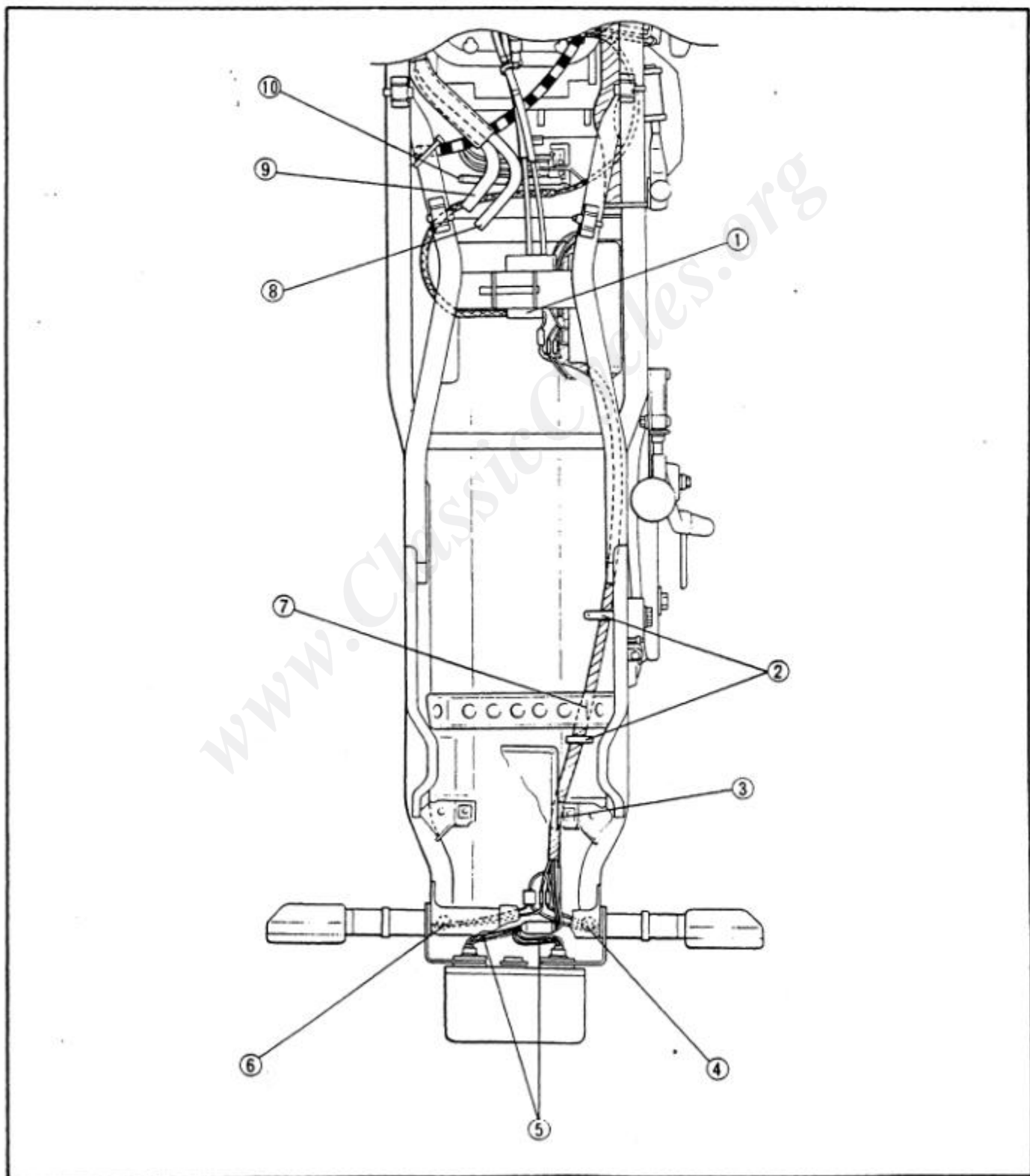

CABLE ROUTING (4)

- | | |
|---|--|
| 1. Coolant reservoir tank | 9. Oil tank |
| 2. CDI unit | 10. Sub oil tank |
| 3. Front flasher light lead (Right) | 11. Oil pipe |
| 4. Clamp | 12. Oil tank breather pipe. Pass the pipe between the radiator cover and sub oil tank. |
| 5. Coolant reservoir tank breather pipe | |
| 6. Carburetor overflow pipe | |
| 7. YPVS control unit | |
| 8. Oil level gauge lead | |

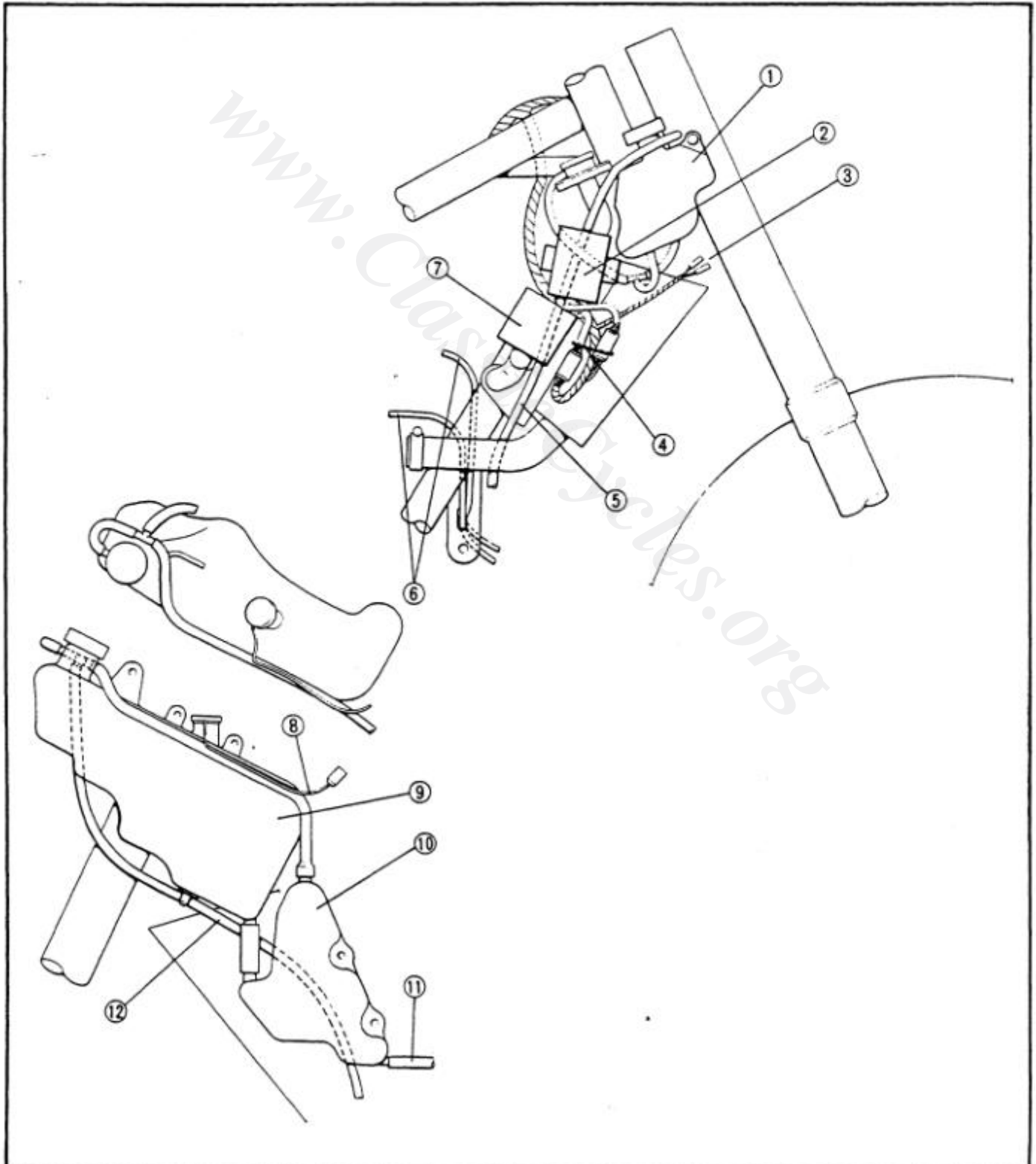



CABLE ROUTING (5)

- 1. To main switch
- 2. Clamp
- 3. Battery
- 4. To rear brake stop switch
- 5. To YPVS servo motor
- 6. Ground lead
- 7. Rear brake stop switch lead
- 8. Fuse
- 9. To taillight
- 10. Insert the lead between the battery and frame.
- 11. Battery breather pipe

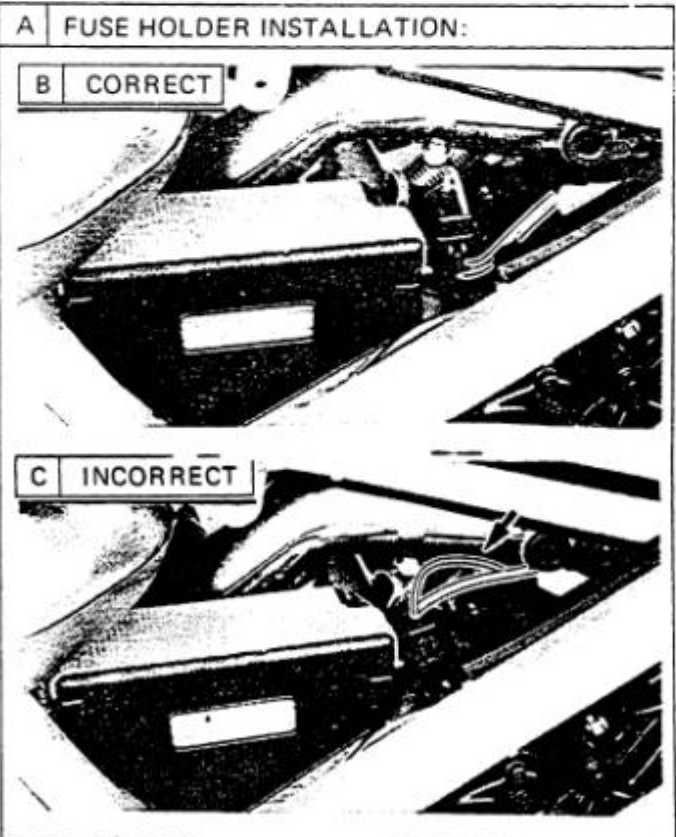
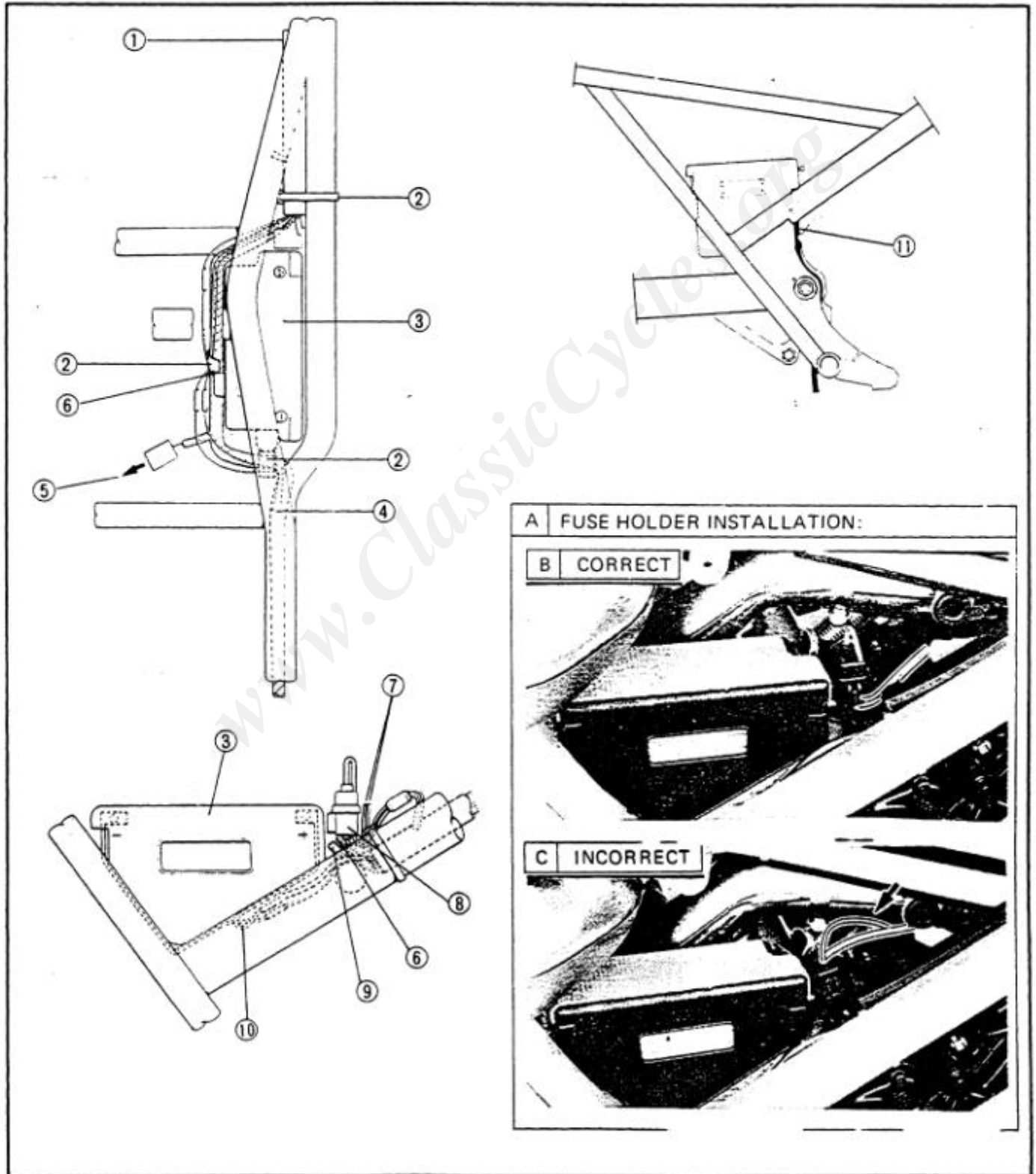



RD500LC '85
47X-SE2

**SERVICE
INFORMATION**

REVISION

The '84 Service Information contains wrong data. Please make correction as per the following.

PAGE	ITEM	INCORRECT	CORRECT
11 35	CARBURETOR: Float Height	21.0 ± 1.0 mm (0.83 ± 0.04 in)	24.0 ± 1.0 mm (0.94 ± 0.04 in)
32	SPARK PLUG: Type	DR9HS	BR9HS
31 36	COOLANT: Total Amount	1.95 L (1.72 Imp qt, 2.06 US qt)	2.3 L (2.02 Imp qt, 2.43 US qt)

www.ClassicCycles.org



CARBURETION

CARBURETOR

- | | |
|-------------------|-------------------------------|
| 1. Top cover | 12. Drain screw |
| 2. Jet needle | 13. Carburetor holder |
| 3. Throttle valve | 14. Starter plunger |
| 4. Needle jet | 15. Synchronizing screw |
| 5. Bracket | 16. Throttle stop screw |
| 6. Pilot jet | 17. Choke lever |
| 7. Main jet | 18. To right upper carburetor |
| 8. Float | 19. To right lower carburetor |
| 9. Pilot air jet | 20. To left lower carburetor |
| 10. Valve seat | 21. To left upper carburetor |
| 11. Float chamber | |

SPECIFICATIONS	
Main jet	# 165
Main air jet	# 1.8 (upper cylinder) # 1.6 (lower cylinder)
Jet needle	5LT14-3
Needle jet	N-8
Pilot jet	# 22.5
Pilot air jet	# 1.4
Fuel level	1.5 ± 1.0 mm (0.06 ± 0.04 in)
Float height	24.0 ± 1.0 mm (0.94 ± 0.04 in)
Float valve seat	φ 2.8
Engine idle speed	1,250 r/min

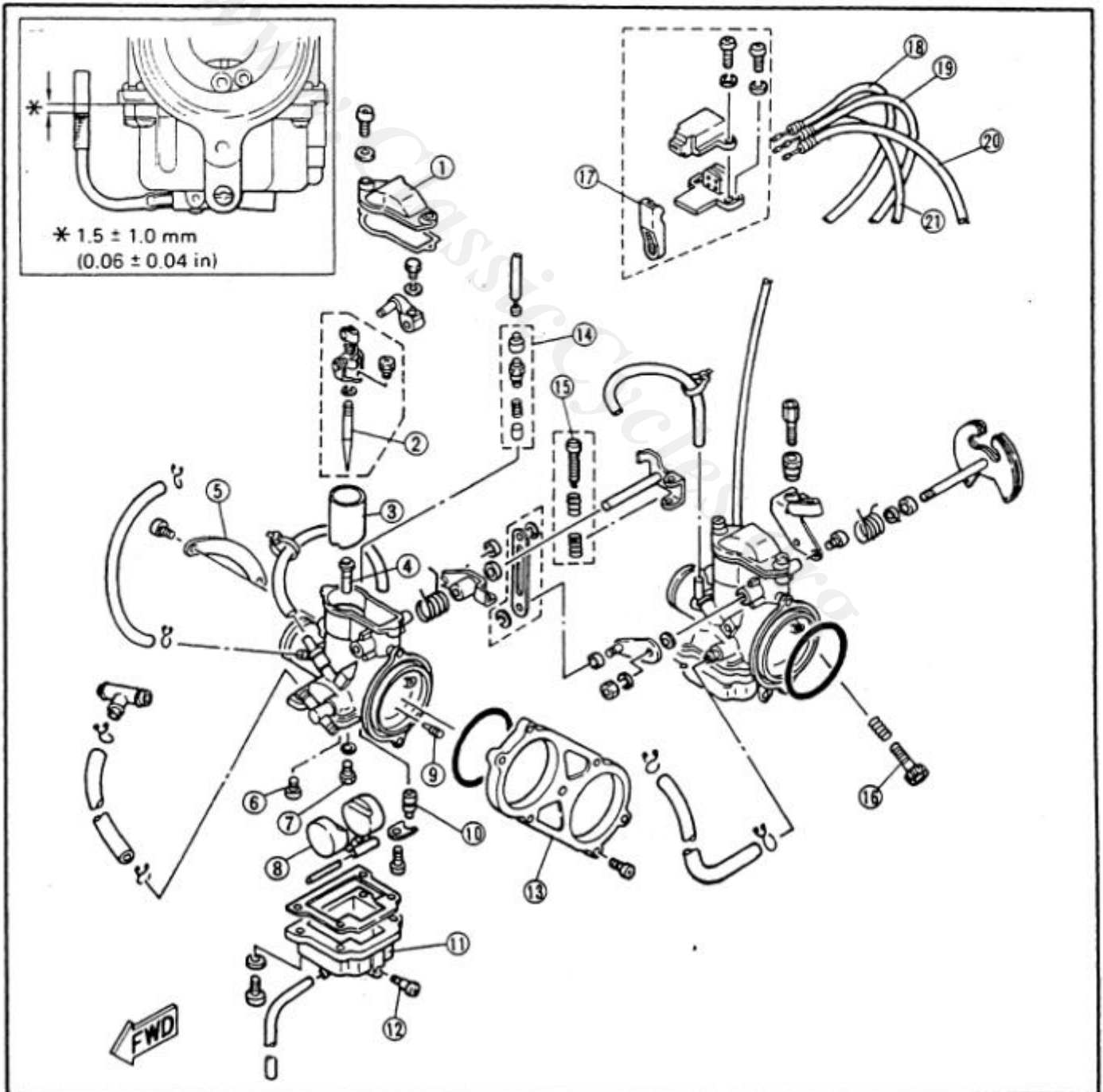



APPENDICES

SPECIFICATIONS

GENERAL SPECIFICATIONS

Model	RD500LC	
Model Code Number: Engine Starting Number: Frame Starting Number:	1GE 47X-004101 47X-004101	
Basic Weight: With Oil and Full Fuel Tank	205 kg (452 lb)	
Engine: Engine Type Cylinder Arrangement Displacement Bore x Stroke Compression Ratio Starting System	Liquid cooled, 2-stroke, gasoline V-4 cylinder 499 cm ³ 56.4 x 50.0 mm (2.22 x 1.97 in) 6.6 : 1 Kick starter	
Radiator Capacity: (Including All Routes)	2.3 L (2.02 Imp qt, 2.43 US qt)	
Spark Plug: Type/Manufacturer Gap	BR9HS/NGK, W27FSR/NIPPONDENSO 0.6 ~ 0.7 mm (0.024 ~ 0.028 in)	
Tire: Type Size (F) Size (R)	Tubeless 120/90 V16 YOKOHAMA F101/MICHELIN A48/DUNLOP K125 130/80 V18 YOKOHAMA R101/MICHELIN M48/DUNLOP K225	
Tire Pressure (Cold tire): Basic Weight: With Oil and Full Fuel Tank Maximum Load * Cold Tire Pressure	205 kg (452 lb) 205 kg (452 lb)	
Up to 90 kg (198 lb) Load *	Front 196 kPa (2.0 kg/cm ² , 28 psi)	Rear 226 kPa (2.3 kg/cm ² , 32 psi)
90 kg (198 lb) ~ Maximum Load *	226 kPa (2.3 kg/cm ² , 32 psi)	284 kPa (2.9 kg/cm ² , 42 psi)
High Speed Riding	226 kPa (2.3 kg/cm ² , 36 psi)	245 kPa (2.5 kg/cm ² , 36 psi)
* Load is the total weight of cargo, rider, passenger, and accessories.		

PARTS & ACCESSORIES

Click on links below

[*Yamaha Motorcycle OEM Parts & Online Schematics*](#)

[*Yamaha Scooter OEM Parts & Online Schematics*](#)

[*Yamaha Cruiser Parts & Accessories*](#)

[*Yamaha Motorcycle Parts & Accessories*](#)

[*Save Up to 45% on Motorcycle Tires*](#)

[*JC Whitney Motorcycle Parts & Accessories*](#)

[*Motorcycle Gear Closeout Sale*](#)

[*Mega Motor Madness*](#)

[*Cycle Gear Free Shipping*](#)



[*www.ClassicCycles.org*](http://www.ClassicCycles.org)