

HOW TO USE THIS MANUAL

This service manual describes the service procedures for the CBR600RR.

Follow the Maintenance Schedule (Section 4) recommendations to ensure that the vehicle is in peak operating condition and the emission levels are within the standards set by the U.S. Environmental Protection Agency (EPA) and California Air Resources Board (CARB) and Transport Canada.

Performing the first scheduled maintenance is very important. It compensates for the initial wear that occurs during the break-in period.

Sections 1 and 4 apply to the whole motorcycle. Section 3 illustrates procedures for removal/installation of components that may be required to perform service described in the following sections. Section 5 through 20 describe parts of the motorcycle, grouped according to location.

Find the section you want on this page, then turn to the table of contents on the first page of the section.

Most sections start with an assembly or system illustration, service information and troubleshooting for the section. The subsequent pages give detailed procedure.

If you are not familiar with this motorcycle, read Technical Features in Section 2.

If you don't know the source of the trouble, go to section 22 Troubleshooting.

Your safety, and the safety of others, is very important. To help you make informed decisions we have provided safety messages and other information throughout this manual. Of course, it is not practical or possible to warn you about all the hazards associated with servicing this vehicle. You must use your own good judgement.

You will find important safety information in a variety of forms including:

- Safety Labels – on the vehicle
- Safety Messages – preceded by a safety alert symbol  and one of three signal words, DANGER, WARNING, or CAUTION.

These signal words mean:

▲ DANGER You WILL be KILLED or SERIOUSLY HURT if you don't follow instructions.

▲ WARNING You CAN be KILLED or SERIOUSLY HURT if you don't follow instructions.

▲ CAUTION You CAN be HURT if you don't follow instructions.

- Instructions – how to service this vehicle correctly and safely.

As you read this manual, you will find information that is preceded by a **NOTICE** symbol. The purpose of this message is to help prevent damage to your vehicle, other property, or the environment.











CONTENTS

	GENERAL INFORMATION	1
	TECHNICAL FEATURES	2
	FRAME/BODY PANELS/EXHAUST SYSTEM	3
	MAINTENANCE	4
ENGINE AND DRIVE TRAIN	LUBRICATION SYSTEM	5
	FUEL SYSTEM (PGM-FI)	6
	COOLING SYSTEM	7
	ENGINE REMOVAL/INSTALLATION	8
	CYLINDER HEAD/VALVES	9
	CLUTCH/STARTER CLUTCH/GEARSHIFT LINKAGE	10
	ALTERNATOR	11
	CRANKCASE/TRANSMISSION	12
	CRANKSHAFT/PISTON/CYLINDER	13
	CHASSIS	FRONT WHEEL/SUSPENSION/STEERING
REAR WHEEL/SUSPENSION		15
HYDRAULIC BRAKE		16
ELECTRICAL	BATTERY/CHARGING SYSTEM	17
	IGNITION SYSTEM	18
	ELECTRIC STARTER	19
	LIGHTS/METERS/SWITCHES	20
	WIRING DIAGRAM	21
	TROUBLESHOOTING	22
	INDEX	23

3U41A0A

SYMBOLS

The symbols used throughout this manual show specific service procedures. If supplementary information is required pertaining to these symbols, it would be explained specifically in the text without the use of the symbols.

	<p>Replace the part (s) with new one (s) before assembly.</p>
	<p>Use recommended engine oil, unless otherwise specified.</p>
	<p>Use molybdenum oil solution (mixture of the engine oil and molybdenum grease in a ratio of 1:1).</p>
	<p>Use multi-purpose grease (Lithium based multi-purpose grease NLGI #2 or equivalent).</p>
	<p>Use molybdenum disulfide grease (containing more than 3% molybdenum disulfide, NLGI #2 or equivalent). Example: Molykote® BR-2 plus manufactured by Dow Corning U.S.A. Multi-purpose M-2 manufactured by Mitsubishi Oil, Japan</p>
	<p>Use molybdenum disulfide paste (containing more than 40% molybdenum disulfide, NLGI #2 or equivalent). Example: Molykote® G-n Paste manufactured by Dow Corning U.S.A. Honda Moly 60 (U.S.A. only) Rocol ASP manufactured by Rocol Limited, U.K. Rocol Paste manufactured by Sumico Lubricant, Japan</p>
	<p>Use silicone grease.</p>
	<p>Apply locking agent. Use a middle strength locking agent unless otherwise specified.</p>
	<p>Apply sealant.</p>
	<p>Use DOT 4 brake fluid. Use the recommended brake fluid unless otherwise specified.</p>
	<p>Use Fork or Suspension Fluid.</p>

ΑΦΑΙΡΕΣΗ

1. GENERAL INFORMATION

SERVICE RULES	1-2	REAR WHEEL/SUSPENSION SPECIFICATIONS	1-10
MODEL IDENTIFICATION.....	1-3	HYDRAULIC BRAKE SPECIFICATIONS...	1-11
GENERAL SPECIFICATIONS.....	1-5	BATTERY/CHARGING SYSTEM SPECIFICATIONS	1-11
LUBRICATION SYSTEM SPECIFICATIONS.....	1-7	IGNITION SYSTEM SPECIFICATIONS	1-11
FUEL SYSTEM (PGM-FI) SPECIFICATIONS	1-7	ELECTRIC STARTER SPECIFICATIONS	1-11
COOLING SYSTEM SPECIFICATIONS	1-7	LIGHTS/METERS/SWITCHES SPECIFICATIONS	1-12
CYLINDER HEAD/VALVES SPECIFICATIONS.....	1-8	STANDARD TORQUE VALUES.....	1-13
CLUTCH/STARTER CLUTCH/GEARSHIFT LINKAGE SPECIFICATIONS	1-8	ENGINE & FRAME TORQUE VALUES....	1-13
CRANKCASE/TRANSMISSION SPECIFICATIONS.....	1-9	LUBRICATION & SEAL POINTS	1-19
CRANKSHAFT/PISTON/CYLINDER SPECIFICATIONS.....	1-9	CABLE & HARNESS ROUTING	1-21
FRONT WHEEL/SUSPENSION/STEERING SPECIFICATIONS	1-10	EMISSION CONTROL SYSTEMS	1-36

GENERAL INFORMATION

SERVICE RULES

1. Use genuine Honda or Honda-recommended parts and lubricants or their equivalents. Parts that don't meet Honda's design specifications may cause damage to the motorcycle.
2. Use the special tools designed for this product to avoid damage and incorrect assembly.
3. Use only metric tools when servicing the motorcycle. Metric bolts, nuts and screws are not interchangeable with English fasteners.
4. Install new gaskets, O-rings, cotter pins, and lock plates when reassembling.
5. When tightening bolts or nuts, begin with the larger diameter or inner bolt first. Then tighten to the specified torque diagonally in incremental steps unless a particular sequence is specified.
6. Clean parts in cleaning solvent upon disassembly. Lubricate any sliding surfaces before reassembly.
7. After reassembly, check all parts for proper installation and operation.
8. Route all electrical wires as shown in the Cable and Harness Routing (page 1-21).

ABBREVIATION

Throughout this manual, the following abbreviations are used to identify the respective parts or systems.

Abbrev. term	Full term
CKP sensor	Crankshaft Position sensor
CMP sensor	Camshaft Position sensor
DLC	Data Link Connector
DTC	Diagnostic Trouble Code
ECM	Engine Control Module
ECT sensor	Engine Coolant Temperature sensor
EEPROM	Electrically Erasable Programmable Read Only Memory
EGCV	Exhaust Gas Control Valve
EGCV POT	Exhaust Gas Control Valve Potentiometer
EOP switch	Engine Oil Pressure switch
EVAP	Evaporative Emission
HDS	Honda Diagnostic System
HESD	Honda Electronic Steering Damper
IACV	Idle Air Control Valve
IAT sensor	Intake Air Temperature sensor
MAP sensor	Manifold Absolute Pressure sensor
MIL	Malfunction Indicator Lamp
PAIR	Pulsed Secondary Air Injection
PGM-FI	Programmed Fuel Injection
SCS connector	Service Check Short connector
TP sensor	Throttle Position sensor
VS sensor	Vehicle Speed sensor

MODEL IDENTIFICATION

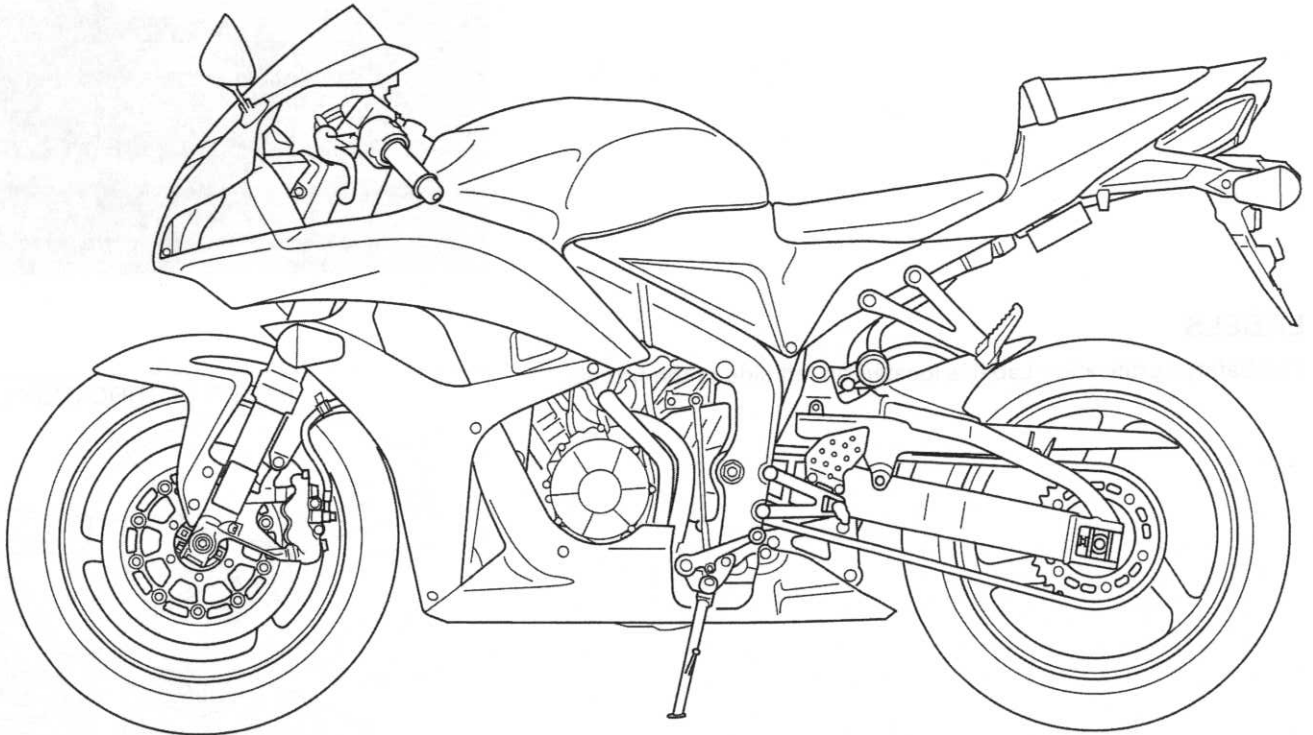

SERIAL NUMBERS

The Vehicle Identification Number (VIN) is stamped on the right side of the steering head.

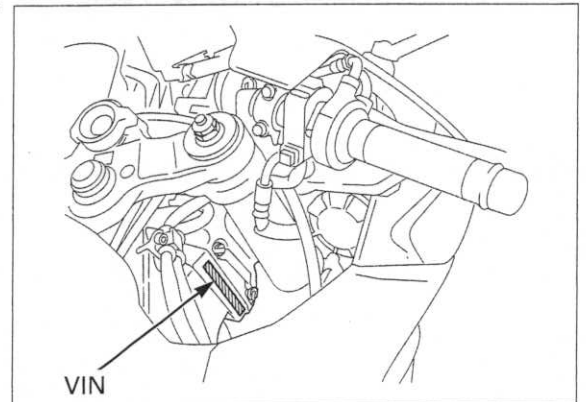

The engine serial number is stamped on the upper side of the crankcase as shown.

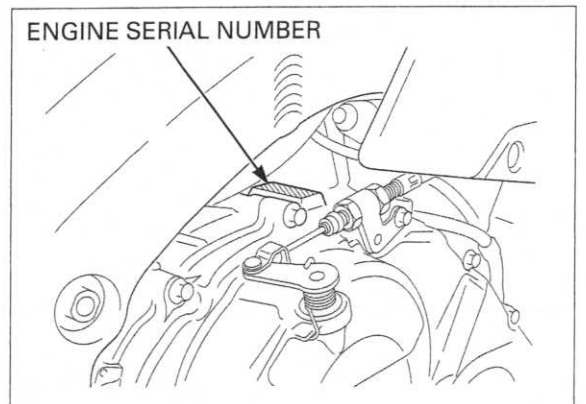

GENERAL INFORMATION

The throttle body identification number is stamped on the right side of the throttle body as shown.

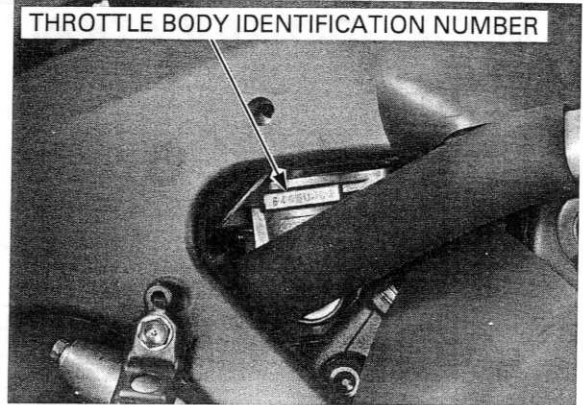

LABELS

The Safety Certification Label is located on left side of the frame.

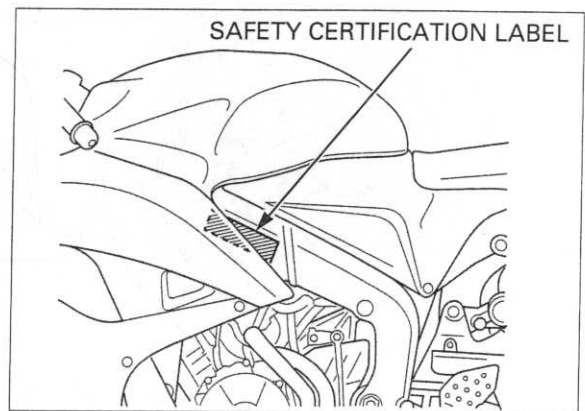

The color label is attached as shown. When ordering color-coded parts, always specify the designated color code.

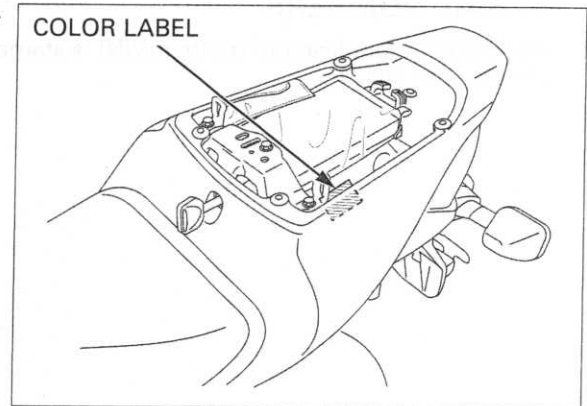

The Emission Control Information Label is located on the rear fender B as shown.

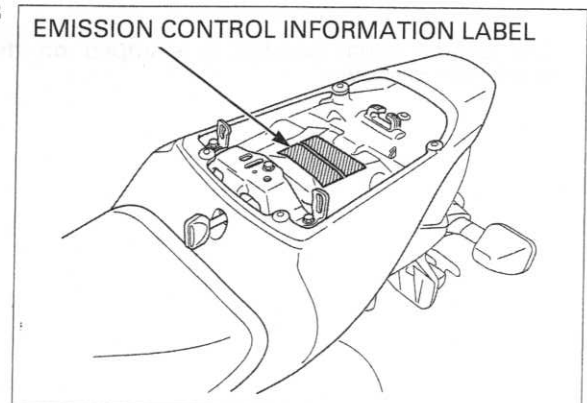

GENERAL SPECIFICATIONS

ITEM		SPECIFICATIONS	
DIMENSIONS	Overall length	2,010 mm (79.1 in)	
	Overall width	685 mm (27.0 in)	
	Overall height	1,105 mm (43.5 in)	
	Wheelbase	1,370 mm (53.9 in)	
	Seat height	820 mm (32.3 in)	
	Footpeg height	389 mm (15.3 in)	
	Ground clearance	135 mm (5.3 in)	
	Curb weight	Except California type California type	186 kg (410 lbs) 187 kg (412 lbs)
FRAME	Maximum weight capacity	Except Canada type Canada type	166 kg (366 lbs) 170 kg (375 lbs)
	Frame type		Diamond
	Front suspension		Telescopic fork
	Front axle travel		110 mm (4.3 in)
	Rear suspension		Swingarm
	Rear axle travel		129 mm (5.1 in)
	Front tire size		120/70ZR17 M/C (58W)
	Rear tire size		180/55ZR17 M/C (73W)
	Front tire brand	Bridgestone Dunlop	BT015F RADIAL E Qualifier PTG
	Rear tire brand	Bridgestone Dunlop	BT015R RADIAL E Qualifier PTG
	Front brake		Hydraulic double disc
	Rear brake		Hydraulic single disc
	Caster angle		23° 55'
	Trail length		98 mm (3.9 in)
Fuel tank capacity		18.0 liter (4.76 US gal, 3.96 Imp gal)	
ENGINE	Cylinder arrangement		4 cylinders in-line, inclined 38° from vertical
	Bore and stroke		67.0 x 42.5 mm (2.64 x 1.67 in)
	Displacement		599 cm ³ (36.5 cu-in)
	Compression ratio		12.2 : 1
	Valve train		Chain driven, DOHC
	Intake valve	opens at 1 mm (0.04 in) lift closes at 1 mm (0.04 in) lift	21° BTDC 44° ABDC
	Exhaust valve	opens at 1 mm (0.04 in) lift closes at 1 mm (0.04 in) lift	40° BBDC 5° ATDC
	Lubrication system		Forced pressure and wet sump
	Oil pump type		Trochoid
	Cooling system		Liquid cooled
	Air filtration		Paper element
	Engine dry weight		57 kg (126 lbs)
Firing order		1 - 2 - 4 - 3	
FUEL DELIVERY SYSTEM	Type		PGM-FI
	Throttle bore		40 mm (1.6 in)
DRIVE TRAIN	Clutch system		Multi-plate, wet
	Clutch operation system		Cable operating
	Transmission		Constant mesh, 6-speeds
	Primary reduction		2.111 (76/36)
	Final reduction		2.625 (42/16)
	Gear ratio	1st	2.750 (33/12)
		2nd	2.000 (32/16)
		3rd	1.667 (30/18)
		4th	1.444 (26/18)
		5th	1.304 (30/23)
	6th	1.208 (29/24)	
	Gearshift pattern		Left foot operated return system, 1 - N - 2 - 3 - 4 - 5 - 6

GENERAL INFORMATION

ELECTRICAL	ITEM	SPECIFICATIONS
	Ignition system	Computer-controlled digital transistorized with electric advance
	Starting system	Electric starter motor
	Charging system	Triple phase output alternator
	Regulator/rectifier	FET shorted/triple phase, full wave rectification
	Lighting system	Battery

LUBRICATION SYSTEM SPECIFICATIONS

Unit: mm (in)

ITEM		STANDARD	SERVICE LIMIT
Engine oil capacity	After draining	2.7 liter (2.9 US qt, 2.4 Imp qt)	-
	After oil filter change	2.8 liter (3.0 US qt, 2.5 Imp qt)	-
	After disassembly	3.5 liter (3.7 US qt, 3.1 Imp qt)	-
Recommended engine oil		Pro Honda GN4 4-stroke oil (U.S.A. and Canada) or equivalent motor oil API service classification: SG or Higher JASO T 903 standard: MA Viscosity: SAE 10W-30	-
Oil pressure at EOP switch		505 kPa (5.1 kgf/cm ² , 73 psi) at 6,000 rpm/(80°C/176°F)	-
Oil pump	Tip clearance	0.15 (0.006)	0.20 (0.008)
	Body clearance	0.15 – 0.21 (0.006 – 0.008)	0.35 (0.014)
	Side clearance	0.04 – 0.09 (0.002 – 0.004)	0.17 (0.007)

FUEL SYSTEM (PGM-FI) SPECIFICATIONS

ITEM		SPECIFICATIONS
Throttle body identification number	Except California type	GQ64C
	California type	GQ64B
Idle speed		1,400 ± 100 rpm
Throttle grip freeplay		2 – 4 mm (1/16 – 3/16 in)
IAT sensor resistance (at 20°C/68°F)		1 – 4 kΩ
ECT sensor resistance (at 20°C/68°F)		2.3 – 2.6 kΩ
Fuel injector resistance (at 20°C /68°F)	Primary injector	11 – 13 Ω
	Secondary injector	11 – 13 Ω
PAIR control solenoid valve resistance (at 20°C/68°F)		23 – 27 Ω
CMP sensor peak voltage (at 20°C/68°F)		0.7 V minimum
CKP sensor peak voltage (at 20°C/68°F)		0.7 V minimum
Fuel pressure at idle		343 kPa (3.5 kgf/cm ² , 50 psi)
Fuel pump flow (at 12V)		167 cm ³ (5.6 US oz, 5.9 Imp oz) minimum/10 seconds

COOLING SYSTEM SPECIFICATIONS

ITEM		SPECIFICATIONS
Coolant capacity	Radiator and engine	3.15 liter (3.33 US qt, 2.77 Imp qt)
	Reserve tank	0.30 liter (0.32 US qt, 0.26 Imp qt)
Radiator cap relief pressure		108 – 137 kPa (1.1 – 1.4 kgf/cm ² , 16 – 20 psi)
Thermostat	Begin to open	80 – 84°C (176 – 183°F)
	Fully open	95°C (203°F)
	Valve lift	8 mm (0.3 in) minimum
Recommended antifreeze		Pro Honda HP Coolant or an equivalent high quality ethylene glycol antifreeze containing silicate free corrosion inhibitors
Standard coolant concentration		1:1 (mixture with distilled water)

GENERAL INFORMATION

CYLINDER HEAD/VALVES SPECIFICATIONS

Unit: mm (in)

ITEM		STANDARD	SERVICE LIMIT
Cylinder compression		1,226 kPa (12.5 kgf/cm ² , 178psi) at 350 rpm	-
Valve clearance	IN	0.20 ± 0.03 (0.008 ± 0.001)	-
	EX	0.28 ± 0.03 (0.011 ± 0.001)	-
Camshaft	Cam lobe height	IN	36.36 - 36.60 (1.431 - 1.441)
		EX	35.34 - 35.58 (1.391 - 1.401)
	Runout	-	0.05 (0.002)
Oil clearance		0.020 - 0.062 (0.0008 - 0.0024)	0.10 (0.004)
Valve lifter	Valve lifter O.D.	IN	25.978 - 25.993 (1.0228 - 1.0233)
		EX	22.478 - 22.493 (0.8850 - 0.8855)
	Valve lifter bore I.D.	IN	26.010 - 26.026 (1.0240 - 1.0246)
		EX	22.510 - 22.526 (0.8862 - 0.8868)
Valve, valve guide	Valve stem O.D.	IN	3.975 - 3.990 (0.1565 - 0.1571)
		EX	3.965 - 3.980 (0.1561 - 0.1567)
	Valve guide I.D.	IN/EX	4.000 - 4.012 (0.1575 - 0.1580)
	Stem-to-guide clearance	IN	0.010 - 0.037 (0.0004 - 0.0015)
		EX	0.020 - 0.047 (0.0008 - 0.0019)
	Valve guide projection above cylinder head	IN	17.1 - 17.4 (0.67 - 0.69)
		EX	15.8 - 16.1 (0.62 - 0.63)
Valve seat width	IN/EX	0.90 - 1.10 (0.035 - 0.043)	
Valve spring free length	IN	Inner	36.17 (1.424)
		Outer	40.38 (1.590)
	EX	40.80 (1.606)	
Cylinder head warpage		-	0.10 (0.004)

CLUTCH/STARTER CLUTCH/GEARSHIFT LINKAGE SPECIFICATIONS

Unit: mm (in)

ITEM		STANDARD	SERVICE LIMIT
Clutch lever freeplay		10 - 20 (3/8 - 13/16)	-
Clutch	Spring free length	46.7 (1.84)	45.8 (1.80)
	Disc thickness	2.92 - 3.08 (0.115 - 0.121)	2.6 (0.10)
	Plate warpage	-	0.30 (0.012)
Clutch outer guide	I.D.	24.993 - 25.003 (0.9840 - 0.9844)	25.013 (0.9848)
	O.D.	34.996 - 35.004 (1.3778 - 1.3781)	34.986 (1.3774)
Primary driven gear I.D.		41.000 - 41.016 (1.6142 - 1.6148)	41.026 (1.6152)
Oil pump drive sprocket guide	I.D.	25.000 - 25.021 (0.9843 - 0.9851)	25.031 (0.9855)
	O.D.	34.950 - 34.975 (1.3760 - 1.3770)	34.940 (1.3756)
Oil pump drive sprocket I.D.		35.025 - 35.145 (1.3789 - 1.3837)	35.155 (1.3841)
Mainshaft O.D. at clutch outer guide		24.980 - 24.990 (0.9835 - 0.9839)	24.960 (0.9827)
Mainshaft O.D. at oil pump drive sprocket guide		24.980 - 24.990 (0.9835 - 0.9839)	24.960 (0.9827)
Starter driven gear boss O.D.		45.657 - 45.673 (1.7975 - 1.7981)	45.642 (1.7969)

CRANKCASE/TRANSMISSION SPECIFICATIONS

Unit: mm (in)

ITEM		STANDARD	SERVICE LIMIT
Shift fork	I.D.	12.000 – 12.018 (0.4724 – 0.4731)	12.03 (0.474)
	Claw thickness	5.93 – 6.00 (0.233 – 0.236)	5.9 (0.23)
Shift fork shaft O.D.		11.957 – 11.968 (0.4707 – 0.4712)	11.95 (0.470)
Transmission	Gear I.D.	M5, M6	28.000 – 28.021 (1.1024 – 1.1032)
		C1	24.000 – 24.021 (0.9449 – 0.9457)
		C2, C3, C4	31.000 – 31.025 (1.2205 – 1.2215)
	Gear busing O.D.	M5, M6	27.959 – 27.980 (1.1007 – 1.1016)
		C2	30.955 – 30.980 (1.2187 – 1.2197)
		C3, C4	30.950 – 30.975 (1.2185 – 1.2195)
	Gear-to-bushing clearance	M5, M6	0.020 – 0.062 (0.0008 – 0.0024)
		C2	0.020 – 0.070 (0.0008 – 0.0028)
		C3, C4	0.025 – 0.075 (0.0010 – 0.0030)
	Gear bushing I.D.	M5	24.985 – 25.006 (0.9837 – 0.9845)
		C2	27.985 – 28.006 (1.1018 – 1.1026)
	Mainshaft O.D.	at M5	24.967 – 24.980 (0.9830 – 0.9835)
	Countershaft O.D.	at C2	27.967 – 27.980 (1.1011 – 1.1016)
Bushing to shaft clearance	M5	0.005 – 0.039 (0.0002 – 0.0015)	
	C2	0.005 – 0.039 (0.0002 – 0.0015)	

CRANKSHAFT/PISTON/CYLINDER SPECIFICATIONS

Unit: mm (in)

ITEM		STANDARD	SERVICE LIMIT	
Crankshaft	Connecting rod side clearance	0.15 – 0.30 (0.006 – 0.012)	0.35 (0.014)	
	Crankpin bearing oil clearance	0.028 – 0.052 (0.0011 – 0.0020)	0.06 (0.002)	
	Main journal bearing oil clearance	0.020 – 0.038 (0.0008 – 0.0015)	0.05 (0.002)	
	Runout	–	0.05 (0.002)	
Piston, piston rings	Piston O.D. at 6 mm (0.2 in) from bottom	66.965 – 66.985 (2.6364 – 2.6372)	66.90 (2.634)	
	Piston pin bore I.D.	15.030 – 15.044 (0.5917 – 0.5923)	15.07 (0.593)	
	Piston pin O.D.	14.994 – 15.000 (0.5903 – 0.5906)	14.98 (0.590)	
	Piston-to-piston pin clearance	0.03 – 0.05 (0.001 – 0.002)	0.09 (0.004)	
	Piston ring end gap	Top	0.10 – 0.20 (0.004 – 0.008)	0.4 (0.02)
		Second	0.21 – 0.31 (0.008 – 0.012)	0.5 (0.02)
		Oil (side rail)	0.2 – 0.7 (0.01 – 0.03)	1.0 (0.04)
Piston ring-to-ring groove clearance	Top	0.030 – 0.060 (0.0012 – 0.0024)	0.10 (0.004)	
	Second	0.115 – 0.150 (0.0045 – 0.0059)	0.08 (0.003)	
Cylinder	I.D.	67.000 – 67.015 (2.6378 – 2.6384)	67.10 (2.642)	
	Out of round	–	0.10 (0.004)	
	Taper	–	0.10 (0.004)	
	Warpage	–	0.10 (0.004)	
Cylinder-to-piston clearance		0.015 – 0.050 (0.0006 – 0.0020)	0.10 (0.004)	
Connecting rod small end I.D.		15.030 – 15.044 (0.5917 – 0.5923)	15.05 (0.593)	
Connecting rod-to-piston pin clearance		0.03 – 0.05 (0.001 – 0.002)	0.07 (0.003)	

GENERAL INFORMATION

FRONT WHEEL/SUSPENSION/STEERING SPECIFICATIONS

Unit: mm (in)

ITEM		STANDARD	SERVICE LIMIT
Minimum tire tread depth		-	1.5 (0.06)
Cold tire pressure	Driver only	250 kPa (2.50 kgf/cm ² , 36 psi)	-
	Driver and passenger	250 kPa (2.50 kgf/cm ² , 36 psi)	-
Axle runout		-	0.2 (0.01)
Wheel rim runout	Radial	-	2.0 (0.08)
	Axial	-	2.0 (0.08)
Wheel balance weight		-	60 g (2.1oz) max.
Fork	Spring free length	243.4 (9.58)	238.5 (9.39)
	Pipe runout	-	0.20 (0.008)
	Recommended fork fluid	Pro Honda Suspension Fluid SS-47 (10 W)	-
	Fluid level	93 (3.7)	-
	Fluid capacity	413 ± 2.5 cm ³ (14.0 ± 0.08 US oz, 14.5 ± 0.09 Imp oz)	-
	Pre-load adjuster initial setting	5 turns from minimum	-
	Rebound damping adjuster initial setting	2-1/2 turns out from full hard	-
	Compression damping adjuster initial setting	2 turns out from full hard	-
Steering head bearing pre-load		14.7 – 17.7 N (1.5 – 1.8 kgf)	-

REAR WHEEL/SUSPENSION SPECIFICATIONS

Unit: mm (in)

ITEM		STANDARD	SERVICE LIMIT
Minimum tire tread depth		-	2.0 (0.08)
Cold tire pressure	Driver only	290 kPa (2.90 kgf/cm ² , 42 psi)	-
	Driver and passenger	290 kPa (2.90 kgf/cm ² , 42 psi)	-
Axle runout		-	0.2 (0.01)
Wheel rim runout	Radial	-	2.0 (0.08)
	Axial	-	2.0 (0.08)
Wheel balance weight		-	60 g (2.1 oz) max.
Drive chain	Size/link	DID	DID525HV KAI-112YB
		RK	RK525ROZ6-112LJFZ
	Slack	30 – 40 (1.2 – 1.6)	-
Shock absorber	Spring pre-load adjuster standard position	Position 2	-
	Rebound damping adjuster initial setting	2-1/2 turns out from full hard	-
	Compression damping adjuster initial setting	22 clicks out from full hard	-

HYDRAULIC BRAKE SPECIFICATIONS

Unit: mm (in)

ITEM		STANDARD	SERVICE LIMIT	
Front	Specified brake fluid	DOT 4	-	
	Brake disc thickness	4.3 - 4.5 (0.17 - 0.18)	3.5 (0.14)	
	Brake disc runout	-	0.30 (0.012)	
	Master cylinder I.D.	17.460 - 17.503 (0.6874 - 0.6891)	17.515 (0.6896)	
	Master piston O.D.	17.321 - 17.367 (0.6819 - 0.6837)	17.309 (0.6815)	
	Caliper cylinder I.D.	A	32.080 - 32.130 (1.2630 - 1.2650)	32.140 (1.2654)
		B	30.280 - 30.330 (1.1921 - 1.1941)	30.340 (1.1945)
	Caliper piston O.D.	A	31.967 - 32.000 (1.2585 - 1.2598)	31.957 (1.2581)
B		30.167 - 30.200 (1.1877 - 1.1890)	30.157 (1.1873)	
Rear	Specified brake fluid	DOT 4	-	
	Brake disc thickness	4.8 - 5.2 (0.19 - 0.20)	4.0 (0.16)	
	Brake disc runout	-	0.30 (0.012)	
	Master cylinder I.D.	14.000 - 14.043 (0.5512 - 0.5529)	14.055 (0.5533)	
	Master piston O.D.	13.957 - 13.984 (0.5495 - 0.5506)	13.945 (0.5490)	
	Caliper cylinder I.D.	30.230 - 30.280 (1.1902 - 1.1921)	30.290 (1.1925)	
	Caliper piston O.D.	30.082 - 30.115 (1.1843 - 1.1856)	30.140 (1.1866)	

BATTERY/CHARGING SYSTEM SPECIFICATIONS

ITEM		SPECIFICATIONS	
Battery	Capacity	12V - 8.6 Ah	
	Current leakage	2.0 mA max.	
	Voltage (20°C/68°F)	Fully charged	13.0 - 13.2 V
		Needs charging	Below 12.4 V
	Charging current	Normal	0.9 A/5 - 10 h
Quick		4.5 A/1 h	
Alternator	Capacity	0.342 kW/5,000 rpm	
	Charging coil resistance (20°C/68°F)	0.1 - 1.0 Ω	

IGNITION SYSTEM SPECIFICATIONS

ITEM		SPECIFICATIONS
Spark plug (Iridium)	NGK	IMR9C-9HES
	DENSO	VUH27D
Spark plug gap		0.80 - 0.90 mm (0.031 - 0.035 in)
CKP sensor peak voltage		0.7 V minimum
Ignition timing ("F"mark)		7.8° BTDC at idle

ELECTRIC STARTER SPECIFICATIONS

Unit: mm (in)

ITEM	STANDARD	SERVICE LIMIT
Starter motor brush length	12.0 (0.47)	6.5 (0.26)

GENERAL INFORMATION

LIGHTS/METERS/SWITCHES SPECIFICATIONS

ITEM		SPECIFICATIONS	
Bulbs	Headlight	Hi	12 V – 55 W
		Lo	12 V – 55 W
	Position light		LED
	Brake/tail/license light		LED
	Front turn signal/position light		12 V – 23/8 W x 2
	Rear turn signal light		12 V – 21 W x 2
	Instrument light		LED
	Turn signal indicator		LED
	High beam indicator		LED
	Neutral indicator		LED
	MIL		LED
	HESD indicator		LED
	Engine oil pressure indicator		LED
	Engine coolant temperature indicator		LED
Fuse	Main fuse		30 A
	Sub fuse		10 A x 4, 20 A x 3
Tachometer peak voltage		10.5 V minimum	
ECT sensor resistance	80°C (176°F)	2.1 – 2.6 kΩ	
	120°C (248°F)	0.6 – 0.7 kΩ	

STANDARD TORQUE VALUES

FASTENER TYPE	TORQUE N·m (kgf·m, lbf·ft)	FASTENER TYPE	TORQUE N·m (kgf·m, lbf·ft)
5 mm bolt and nut	5.2 (0.5, 3.8)	5 mm screw	4.2 (0.4, 3.1)
6 mm bolt and nut	10 (1.0, 7)	6 mm screw	9.0 (1.0, 6.6)
8 mm bolt and nut	22 (2.2, 16)	6 mm flange bolt (8 mm head, large flange)	12 (1.2, 9)
10 mm bolt and nut	34 (3.5, 25)	8 mm flange bolt and nut	27 (2.8, 20)
12 mm bolt and nut	54 (5.5, 40)	10 mm flange bolt and nut	39 (4.0, 29)

ENGINE & FRAME TORQUE VALUES

- Torque specifications listed below are for important fasteners.
- Others should be tightened to standard torque values listed above.

ENGINE

MAINTENANCE

ITEM	Q'TY	THREAD DIA. (mm)	TORQUE N·m (kgf·m, lbf·ft)	REMARKS
Spark plug	4	10	16 (1.6, 12)	
Timing hole cap	1	45	18 (1.8, 13)	Apply grease to the threads
Oil filter cartridge	1	20	26 (2.7, 19)	Apply oil to the threads and O-ring
Oil drain bolt	1	12	30 (3.1, 22)	
Oil filter boss	1	20	-	See page 4-18 Apply locking agent to the crankcase side threads

LUBRICATION SYSTEM

ITEM	Q'TY	THREAD DIA. (mm)	TORQUE N·m (kgf·m, lbf·ft)	REMARKS
Oil pump assembly bolt	1	6	12 (1.2, 9)	CT bolt
Oil pump driven sprocket bolt	1	6	15 (1.5, 11)	Apply locking agent to the threads
Oil cooler bolt	1	20	59 (6.0, 44)	Apply oil to the threads
Oil pipe A mounting bolt	2	6	12 (1.2, 9)	Apply locking agent to the threads

FUEL SYSTEM (PGM-FI)

ITEM	Q'TY	THREAD DIA. (mm)	TORQUE N·m (kgf·m, lbf·ft)	REMARKS
ECT sensor	1	12	23 (2.3, 17)	
Primary fuel rail mounting bolt	4	5	5.1 (0.5, 3.8)	
Secondary fuel rail mounting bolt	4	5	5.3 (0.5, 3.9)	
IACV setting plate torx screw	2	4	2.1 (0.2, 1.5)	
Knock sensor mounting bolt	1	8	22 (2.2, 16)	

COOLING SYSTEM

ITEM	Q'TY	THREAD DIA. (mm)	TORQUE N·m (kgf·m, lbf·ft)	REMARKS
Water pump assembly bolt	4	6	12 (1.2, 9)	CT bolt
Thermostat housing cover bolt	2	6	12 (1.2, 9)	CT bolt

ENGINE REMOVAL/INSTALLATION

ITEM	Q'TY	THREAD DIA. (mm)	TORQUE N·m (kgf·m, lbf·ft)	REMARKS
Drive sprocket bolt	1	10	54 (5.5, 40)	

GENERAL INFORMATION

CYLINDER HEAD/VALVES

ITEM	Q'TY	THREAD DIA. (mm)	TORQUE N·m (kgf·m, lbf·ft)	REMARKS
Cylinder head bolt	10	9	47 (4.8, 35)	Apply oil to the threads and seating surface
Camshaft holder bolt	20	6	12 (1.2, 9)	Apply oil to the threads and seating surface
Cylinder head cover bolt	4	6	10 (1.0, 7)	
PAIR check valve cover bolt	4	6	12 (1.2, 9)	Apply locking agent to the threads
Cam sprocket bolt	4	7	20 (2.0, 15)	Apply locking agent to the threads
CMP sensor rotor bolt	2	6	12 (1.2, 9)	Apply locking agent to the threads
Cam chain tensioner A pivot bolt	1	6	12 (1.2, 9)	Apply locking agent to the threads
Cam chain tensioner B pivot bolt	1	10	20 (2.0, 15)	Apply locking agent to the threads
Cam chain guide A bolt	1	6	12 (1.2, 9)	
Insulator mounting bolt	6	6	12 (1.2, 9)	

CLUTCH/STARTER CLUTCH/GEARSHIFT LINKAGE

ITEM	Q'TY	THREAD DIA. (mm)	TORQUE N·m (kgf·m, lbf·ft)	REMARKS
Clutch center lock nut	1	22	128 (13.1, 94)	Apply oil to the threads and seating surface, stake
Clutch spring bolt	5	6	12 (1.2, 9)	
Shift drum center bolt	1	8	23 (2.3, 17)	Apply locking agent to the threads
Shift drum stopper arm pivot bolt	1	6	12 (1.2, 9)	Apply locking agent to the threads
Gearshift spindle stopper pin	1	8	22 (2.2, 16)	
Starter clutch mounting bolt	1	10	83 (8.5, 61)	Apply oil to the threads and seating surface

ALTERNATOR

ITEM	Q'TY	THREAD DIA. (mm)	TORQUE N·m (kgf·m, lbf·ft)	REMARKS
Stator mounting bolt	4	6	12 (1.2, 9)	
Flywheel bolt	1	10	103 (10.5, 76)	Apply oil to the threads and seating surface
Stator wire clamp bolt	1	6	12 (1.2, 9)	CT bolt

CRANKCASE/TRANSMISSION

ITEM	Q'TY	THREAD DIA. (mm)	TORQUE N·m (kgf·m, lbf·ft)	REMARKS
Mainshaft bearing set plate bolt	3	6	12 (1.2, 9)	Apply locking agent to the threads
Shift drum bearing set bolt	2	6	12 (1.2, 9)	Apply locking agent to the threads
Crankcase 6 mm bolt	10	6	12 (1.2, 9)	
8 mm bolt	6	8	24 (2.4, 18)	
8 mm bolt (main journal bolt)	10	8	15 (1.5, 11) + 120°	See page 12-17 Replace with a new one
10 mm bolt	1	10	39 (4.0, 29)	

GENERAL INFORMATION

CRANKSHAFT/PISTON/CYLINDER

ITEM	Q'TY	THREAD DIA. (mm)	TORQUE N·m (kgf·m, lbf·ft)	REMARKS
Crankpin bearing cap bolt (new)	8	7	20 (2.0, 15) + 90°	Apply oil to the threads and seating surface
Crankpin bearing cap bolt (retightening)	8	7	14 (1.4, 10) + 90°	Apply oil to the threads and seating surface
Oil jet pipe mounting bolt	2	6	12 (1.2, 9)	Apply locking agent to the threads

ELECTRIC STARTER

ITEM	Q'TY	THREAD DIA. (mm)	TORQUE N·m (kgf·m, lbf·ft)	REMARKS
Starter motor terminal nut	1	6	10 (1.0, 7)	

LIGHTS/METERS/SWITCHES

ITEM	Q'TY	THREAD DIA. (mm)	TORQUE N·m (kgf·m, lbf·ft)	REMARKS
EOP switch	1	PT 1/8	12 (1.2, 9)	Apply sealant to the threads
EOP switch wire terminal bolt	1	4	2.0 (0.2, 1.5)	
Neutral switch	1	10	12 (1.2, 9)	

GENERAL INFORMATION

FRAME

FRAME/BODY PANELS/EXHAUST SYSTEM

ITEM	Q'TY	THREAD DIA. (mm)	TORQUE N·m (kgf·m, lbf·ft)	REMARKS
Lower cowl-to-middle cowl screw	4	5	1.5 (0.2, 1.1)	
Windscreen mounting screw	6	5	0.45 (0.05, 0.3)	
Seat rail mounting nut	2	10	54 (5.5, 40)	
Seat rail mounting bolt	2	10	44 (4.5, 32)	
Seat rail assembly bolt	2	8	30 (3.1, 22)	
Muffler band bolt	1	8	17 (1.7, 13)	
Exhaust pipe joint nut	8	7	12 (1.2, 9)	
Front fender mounting screw	6	6	12 (1.2, 9)	
Rearview mirror mounting bolt	4	6	7.0 (0.7, 5.2)	
Exhaust pipe mounting bolt	1	8	17 (1.7, 13)	
Main step bracket mounting bolt	4	8	37 (3.8, 27)	
Passenger step bracket mounting bolt	4	8	26 (2.7, 19)	
Exhaust pipe stud	8	8	–	See page 3-26
Position light mounting screw	2	5	1.8 (0.2, 1.3)	
Rear fender bracket mounting bolt	4	6	12 (1.2, 9)	
Air duct mounting bolt	4	6	12 (1.2, 9)	ALOC bolt; replace with a new one

MAINTENANCE

ITEM	Q'TY	THREAD DIA. (mm)	TORQUE N·m (kgf·m, lbf·ft)	REMARKS
Air cleaner element mounting screw	3	5	4.2 (0.4, 3.1)	

FUEL SYSTEM (PGM-FI)

ITEM	Q'TY	THREAD DIA. (mm)	TORQUE N·m (kgf·m, lbf·ft)	REMARKS
Fuel pump mounting nut	6	6	12 (1.2, 9)	
EGCV pulley nut	1	6	5.0 (0.5, 3.7)	
Bank angle sensor mounting screw	2	4	1.5 (0.2, 1.1)	
Fuel tank mounting bolt	2	8	30 (3.1, 22)	
Air funnel/lower housing mounting screw	6	5	4.2 (0.4, 3.1)	
IAT sensor mounting screw	2	5	1.1 (0.1, 0.8)	
MAP sensor mounting screw	1	5	1.1 (0.1, 0.8)	
ECM setting plate screw	2	4	0.7 (0.07, 0.5)	

COOLING SYSTEM

ITEM	Q'TY	THREAD DIA. (mm)	TORQUE N·m (kgf·m, lbf·ft)	REMARKS
Fan motor nut	3	5	4.9 (0.5, 3.6)	
Fan motor shroud mounting bolt	3	6	8.4 (0.9, 6.2)	

ENGINE REMOVAL/INSTALLATION

ITEM	Q'TY	THREAD DIA. (mm)	TORQUE N·m (kgf·m, lbf·ft)	REMARKS
Front engine hanger bolt	2	12	54 (5.5, 40)	
Upper engine hanger adjusting bolt	1	20	10 (1.0, 7)	
Upper engine hanger lock nut	1	20	54 (5.5, 40)	
Upper engine hanger nut	1	12	59 (6.0, 44)	
Lower engine hanger adjusting bolt	1	20	10 (1.0, 7)	
Lower engine hanger lock nut	1	20	54 (5.5, 40)	
Lower engine hanger nut	1	12	59 (6.0, 44)	

FRONT WHEEL/SUSPENSION/STEERING

ITEM	Q'TY	THREAD DIA. (mm)	TORQUE N·m (kgf·m, lbf·ft)	REMARKS
Handlebar weight mounting screw	2	6	9.8 (1.0, 7)	ALOC screw; replace with a new one
Front brake disc bolt	12	6	20 (2.0, 15)	ALOC screw; replace with a new one
Front axle bolt	1	14	59 (6.0, 44)	
Front axle holder bolt	4	8	22 (2.2, 16)	
Fork socket bolt	2	10	34 (3.5, 25)	
Fork damper rod lock nut	2	10	20 (2.0, 15)	
Fork bolt	2	44	34 (3.5, 25)	
Handlebar pinch bolt	2	8	27 (2.8, 20)	
Top bridge pinch bolt	2	8	22 (2.2, 16)	
Bottom bridge pinch bolt	2	8	27 (2.8, 20)	
Steering stem adjusting nut	1	26	-	See page 14-41
Steering stem adjusting lock nut	1	26	-	See page 14-41
Steering stem nut	1	24	103 (10.5, 76)	
Compression adjuster plug bolt	2	14	17 (1.7, 13)	
Steering damper mounting bolt	4	6	10 (1.0, 7)	
Second arm nut	2	6	12 (1.2, 9)	U-nut

REAR WHEEL/SUSPENSION

ITEM	Q'TY	THREAD DIA. (mm)	TORQUE N·m (kgf·m, lbf·ft)	REMARKS
Rear brake disc bolt	4	8	42 (4.3, 31)	ALOC bolt; replace with a new one
Driven sprocket nut	6	10	64 (6.5, 47)	U-nut
Rear axle nut	1	22	113 (11.5, 83)	U-nut
Rear shock absorber mounting nut	2	10	44 (4.5, 32)	U-nut
Shock arm-to-swingarm nut	1	10	44 (4.5, 32)	U-nut
Drive chain case bolt	3	6	12 (1.2, 9)	
Drive chain slider bolt	3	6	9.0 (0.9, 6.6)	ALOC bolt; replace with a new one
Swingarm pivot adjusting bolt	1	30	12 (1.2, 9)	Apply oil to the threads
Swingarm pivot lock nut	1	30	64 (6.5, 47)	
Swingarm pivot nut	1	18	93 (9.5, 69)	
Shock link nut	2	10	44 (4.5, 32)	U-nut

GENERAL INFORMATION

HYDRAULIC BRAKE

ITEM	Q'TY	THREAD DIA. (mm)	TORQUE N·m (kgf·m, lbf·ft)	REMARKS
Front master cylinder reserve tank stopper plate screw	1	4	1.2 (0.1, 0.9)	Apply silicone grease to the slid- ing surface
Front brake lever pivot bolt	1	6	1.0 (0.1, 0.7)	
Front brake lever pivot nut	1	6	6.0 (0.6, 4.4)	Apply locking agent to the threads ALOC bolt; replace with a new one
Front brake light switch screw	1	4	1.2 (0.1, 0.9)	
Front master cylinder holder bolt	2	6	12 (1.2, 9)	
Front brake caliper assembly torx bolt	8	8	22 (2.2, 16)	
Front brake caliper mounting bolt	4	10	45 (4.6, 33)	
Front brake reserve tank stay bolt	1	6	12 (1.2, 9)	
Rear master cylinder push rod lock nut	1	8	18 (1.8, 13)	
Rear master cylinder reserve tank cap screw	2	4	1.5 (0.2, 1.1)	
Rear master cylinder mounting bolt	2	6	10 (1.0, 7)	
Rear brake reserve tank mounting bolt	1	6	12 (1.2, 9)	
Rear brake hose joint screw	1	4	1.5 (0.2, 1.1)	Apply locking agent to the threads
Front brake caliper pad pin	2	10	15 (1.5, 11)	
Rear brake caliper pad pin	1	10	18 (1.8, 13)	
Brake hose oil bolt	5	10	34 (3.5, 25)	
Front brake hose clamp bolt	1	6	9.0 (0.9, 6.6)	
Front brake hose clamp nut	1	6	10 (1.0, 7)	
Front brake hose 3-way joint bolt	1	6	10 (1.0, 7)	
Front brake caliper bleed valve	2	8	8.0 (0.8, 5.9)	
Rear brake caliper bleed valve	1	8	6.0 (0.6, 4.4)	

LIGHTS/METERS/SWITCHES

ITEM	Q'TY	THREAD DIA. (mm)	TORQUE N·m (kgf·m, lbf·ft)	REMARKS
Combination meter screw	9	5	1.0 (0.1, 0.7)	Replace with a new one
Ignition switch mounting bolt	2	8	24 (2.4, 18)	
Headlight mounting screw	2	5	1.8 (0.2, 1.3)	ALOC bolt; replace with a new one
Sidestand switch mounting bolt	1	6	10 (1.0, 7)	
Right handlebar switch housing screw	2	4	0.9 (0.09, 0.7)	ALOC bolt; replace with a new one
Mirror stay mounting bolt	6	6	12 (1.2, 9)	

OTHERS

ITEM	Q'TY	THREAD DIA. (mm)	TORQUE N·m (kgf·m, lbf·ft)	REMARKS
Sidestand pivot bolt	1	10	10 (1.0, 7)	
Sidestand pivot nut	1	10	29 (3.0, 21)	

LUBRICATION & SEAL POINTS

ENGINE

MATERIAL	LOCATION	REMARKS
Liquid sealant (Three Bond 1207B or equivalent)	Crankcase mating surface Oil pan mating surface Right crankcase cover mating surface Alternator cover mating surface EOP switch threads Alternator cover wire grommet Right crankcase cover wire grommet Cylinder head semi-circular cut-out	See page 12-16 See page 5-7 See page 10-26 See page 11-6 See page 9-34
Molybdenum disulfide oil (a mixture of 1/2 engine oil and 1/2 molybdenum disulfide grease)	Main journal bearing sliding surface Piston pin sliding surface Crankpin bearing sliding surface Connecting rod small end inner surface Crankshaft thrust surface Camshaft lobes and journals Valve stem (valve guide sliding surface) Valve lifter sliding surface Oil pump drive sprocket guide sliding surface Water pump shaft and thrust washer sliding surface Clutch outer sliding surface Clutch outer guide sliding surface M3/4, C5, C6 shifter gear (shift fork grooves) Starter reduction gear sliding surface Starter idle gear shaft sliding surface Cylinder head bolt threads and seating surface	
Engine oil	Piston and piston ring sliding surface Clutch disc surface Starter one-way clutch sliding surface Crankpin bearing cap bolt threads and seating surface Flywheel bolt threads and seating surface Clutch center lock nut threads and seating surface Oil filter cartridge threads and O-ring Oil cooler bolt threads and sealing washer seating surface Camshaft holder bolt threads and seating surface Each gear teeth and rotating surface Each bearing Each O-ring Each seal ring Other rotating area and sliding surface Starter clutch mounting bolt threads and seating surface	
Multi-purpose grease	Timing hole cap threads Each oil seal lips	
Locking agent	CMP sensor rotor bolt threads Oil pump driven sprocket bolt threads Shift drum bearing set plate bolt threads Mainshaft bearing set plate bolt threads Cam sprocket bolt threads Shift drum center bolt threads Cam chain tensioner A pivot bolt threads Cam chain tensioner B pivot bolt threads Shift drum stopper arm pivot bolt threads Oil pump drive chain guide mounting bolt threads Shift spindle setting plate bolt threads Oil jet pipe mounting bolt threads Oil level plate bolt threads Oil pipe A/B mounting bolt threads PAIR check valve cover bolt threads Oil filter boss threads (crankcase side)	Coating width: 6.5 ± 1 mm Coating width: 6.5 ± 1 mm Coating width: 6.5 ± 1 mm Coating width: 6.5 ± 1 mm Coating width: 6.5 ± 1 mm Coating width: 6.5 ± 1 mm Coating width: 6.5 ± 1 mm Coating width: 6.5 ± 1 mm Coating width: 6.5 ± 1 mm Coating width: 6.5 ± 1 mm Coating width: 6.5 ± 1 mm Coating width: 6.5 ± 1 mm Coating width: 6.5 ± 1 mm Coating width: 6.5 ± 1 mm Coating width: 6.5 ± 1 mm Coating width: 6.5 ± 1 mm

GENERAL INFORMATION

FRAME

MATERIAL	LOCATION	REMARKS
Multi-purpose grease	Passenger seat catch hook sliding area Front wheel dust seal lips Rear wheel dust seal lips Throttle pipe sliding surface Clutch lever pivot bolt sliding surface Rear brake pedal pivot sliding surface Gearshift pedal link tie rod ball joints Gearshift pedal pivot sliding surface Sidestand pivot sliding surface Axle surface Swingarm pivot bolt surface	
Urea based multi-purpose grease with extreme pressure (example: EXCELITE EP2 manufactured by KYODO YUSHI, Japan) or equivalent	Steering head bearing sliding surface Steering head dust seal lips Steering stem adjusting nut threads	3 - 5 g 3 - 5 g 0.1 - 0.3 g
Multi-purpose grease (Shell Alvania EP2 or equivalent)	Swingarm pivot bearings Swingarm pivot dust seal lips Shock link needle bearings Shock link dust seal lips Shock absorber needle bearing Shock absorber dust seal lips	
Cable lubricant	Throttle cable inside Clutch cable inside EGCV control cable inside	
Honda bond A or Pro Honda hand grip cement (U.S.A. only)	Handlebar grip rubber inner surface	
Engine oil	Swingarm pivot adjusting bolt threads Each O-ring	
Silicone grease	Front brake push rod-to-master piston contact surface Front brake push rod tip Front brake lever pivot bolt sliding surface Rear brake master piston-to-push rod contacting area Rear brake caliper pin sliding surface Rear brake caliper pad pin O-ring	0.1 g 0.1 g 0.4 g
DOT 4 brake fluid	Brake master piston and cups Brake caliper piston and piston seals	
Fork fluid	Fork O-ring Fork dust seal and oil seal lips	
Locking agent	Front brake caliper assembly torx bolt threads Cooling fan nut threads	

CABLE & HARNESS ROUTING

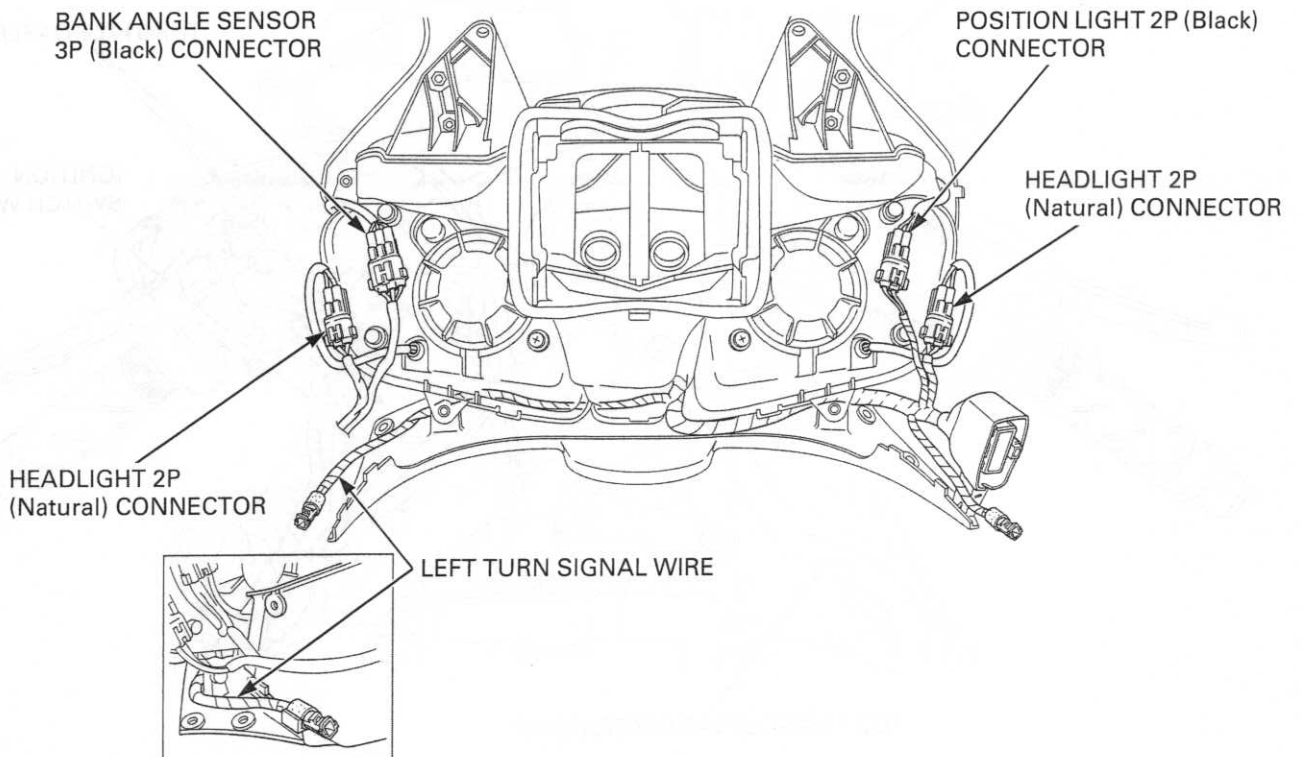
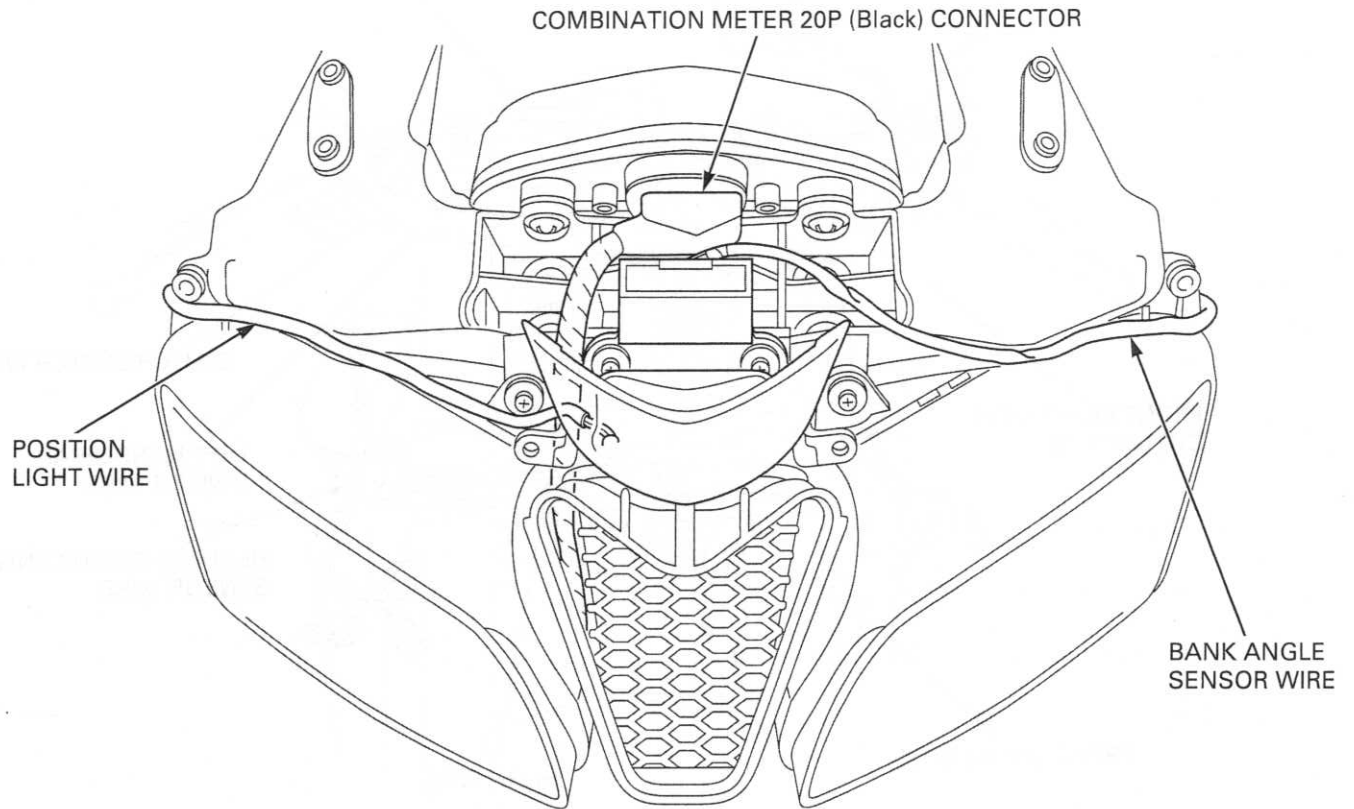

GENERAL INFORMATION

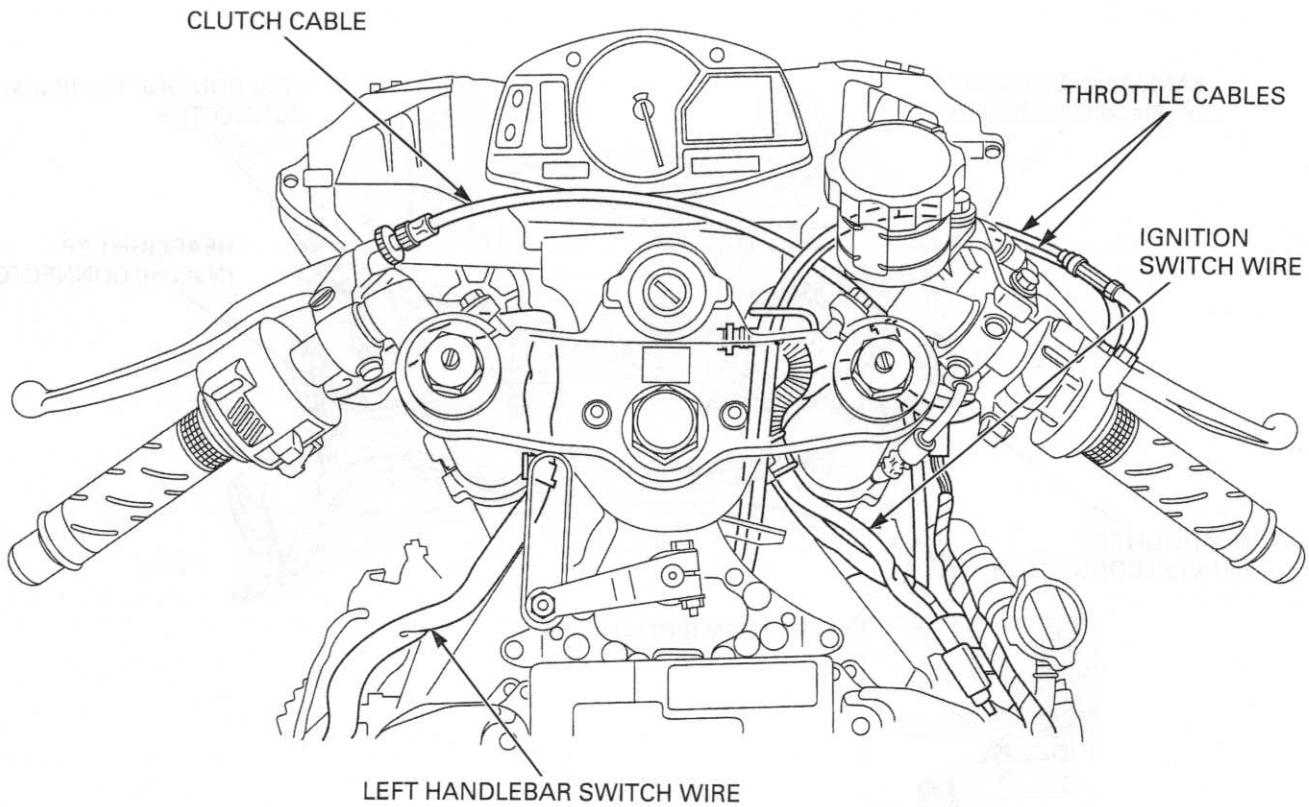
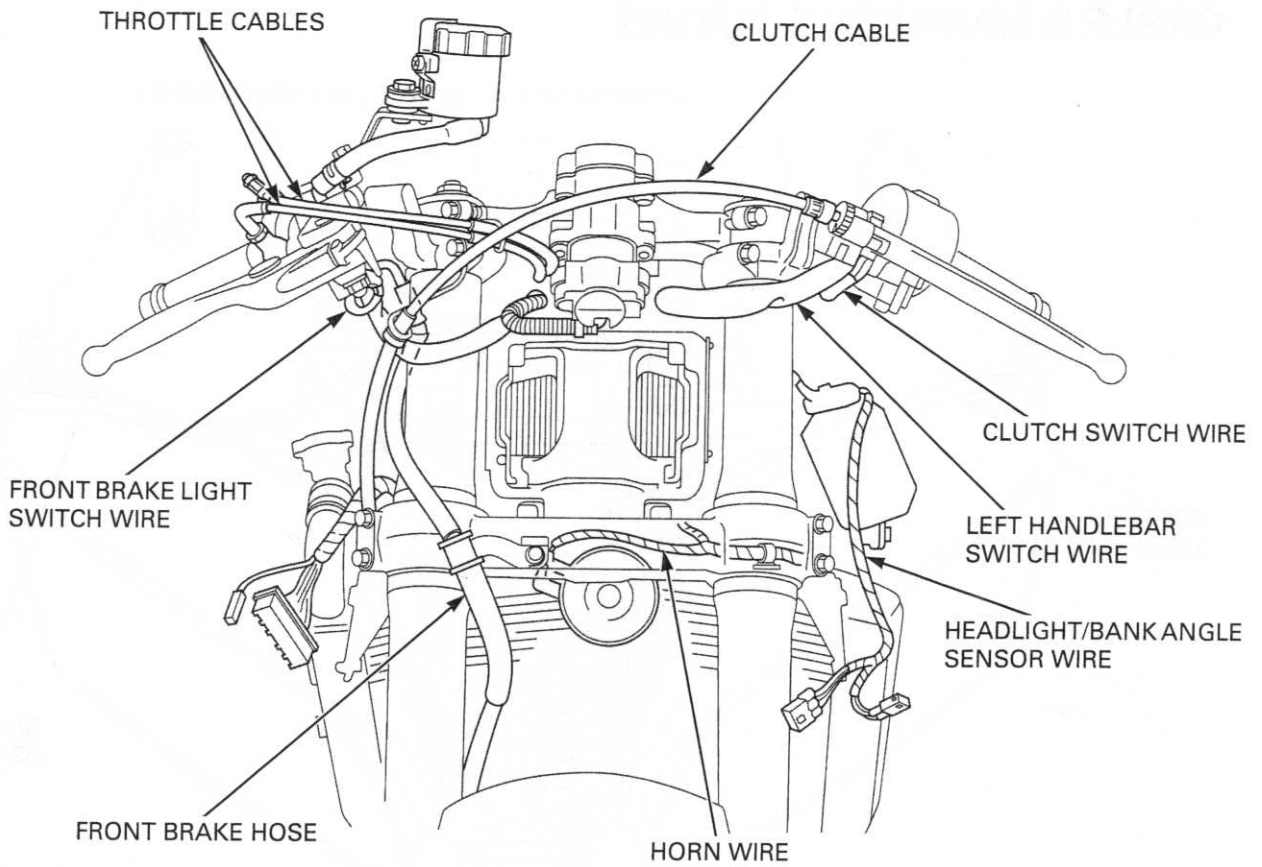

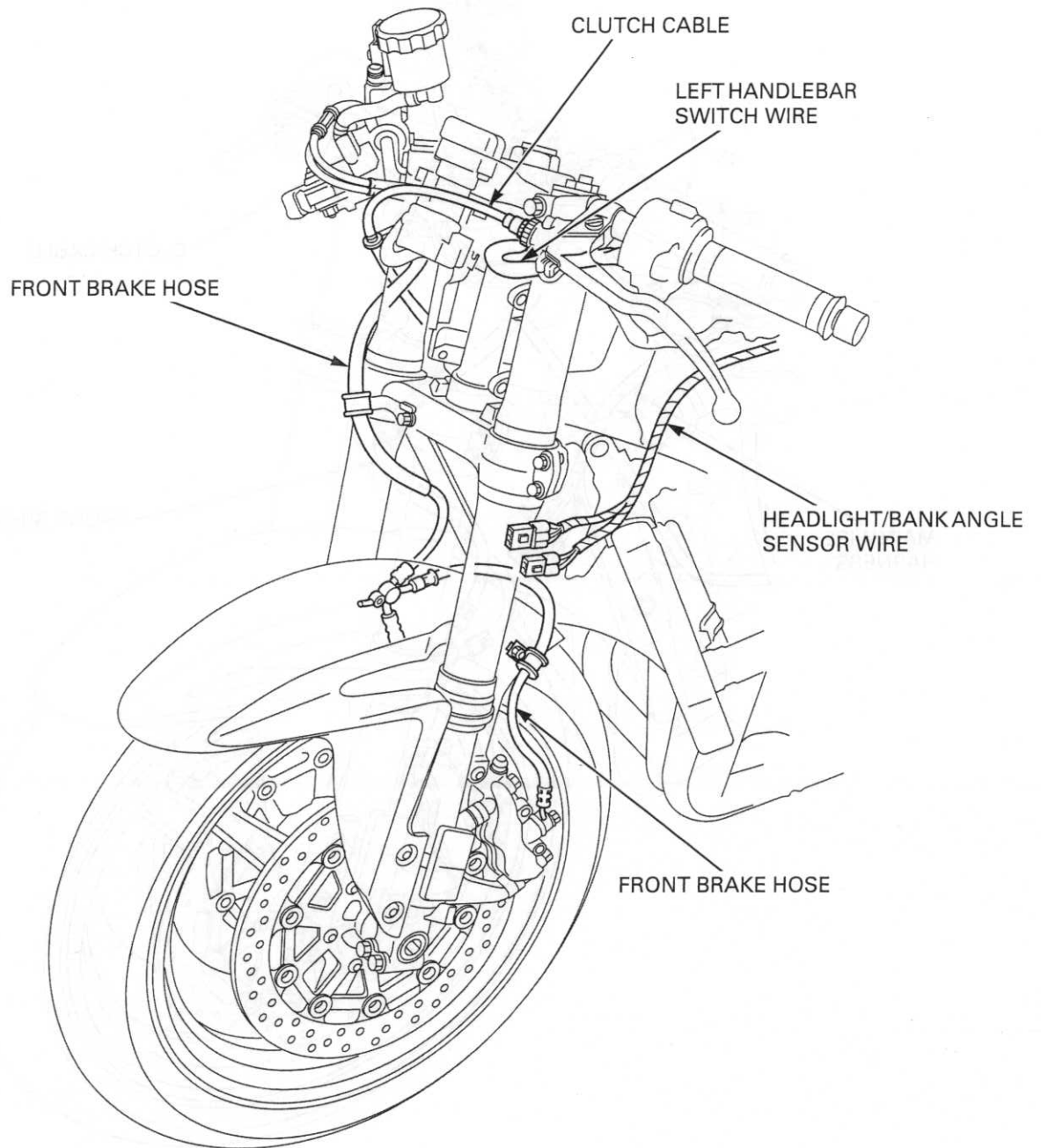

GENERAL INFORMATION

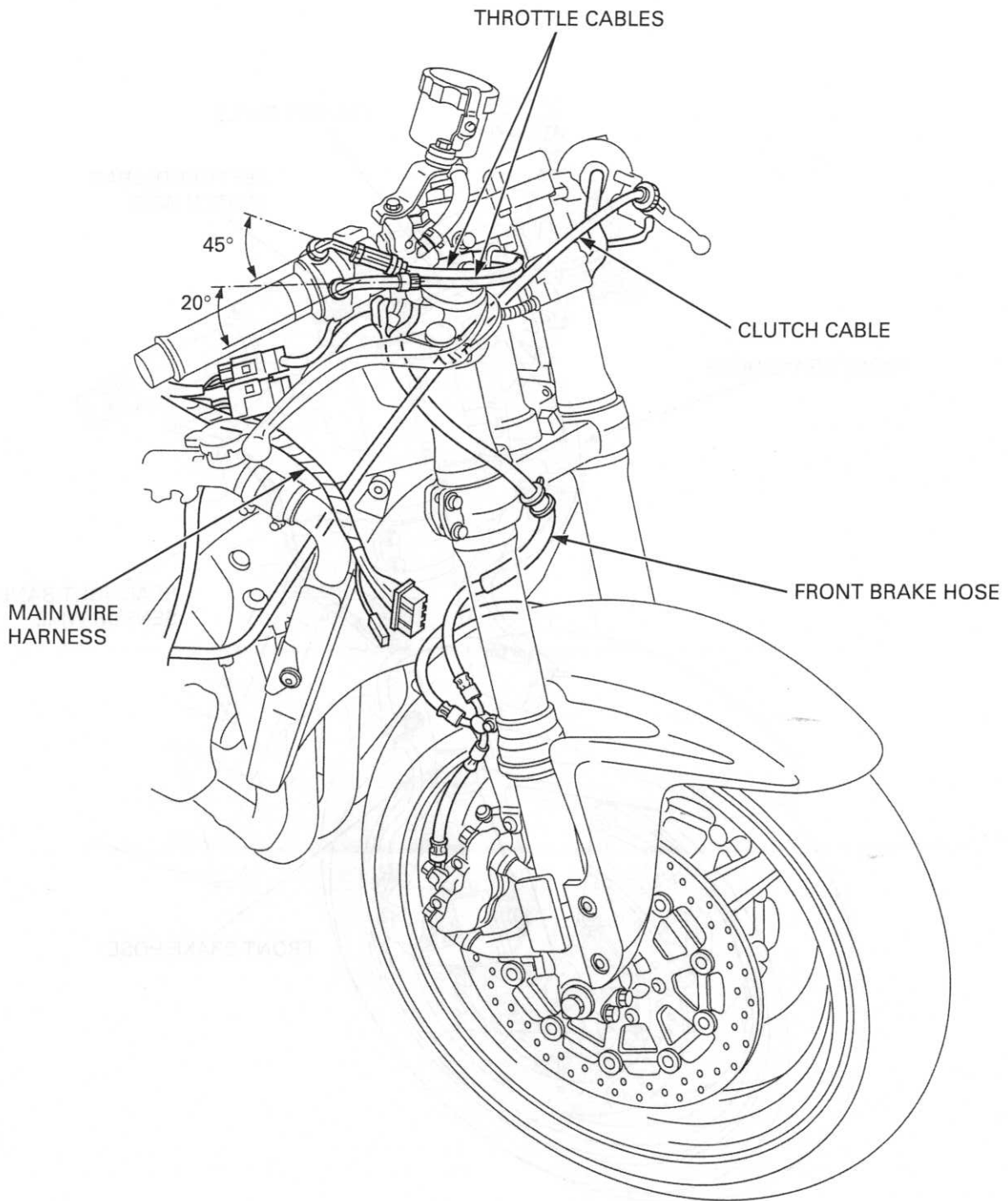

BANK ANGLE SENSOR
3P (Black) CONNECTOR

HEADLIGHT 2P (Natural)
CONNECTOR

LEFT HANDLEBAR SWITCH
12P (Gray) CONNECTOR

IGNITION SWITCH 2P
(Brown) CONNECTOR

POSITION LIGHT 2P
(Black) CONNECTOR

RIGHT HANDLEBAR SWITCH
8P (Gray) CONNECTOR

CLUTCH CABLE

HEADLIGHT 2P
(Natural) CONNECTOR

GENERAL INFORMATION

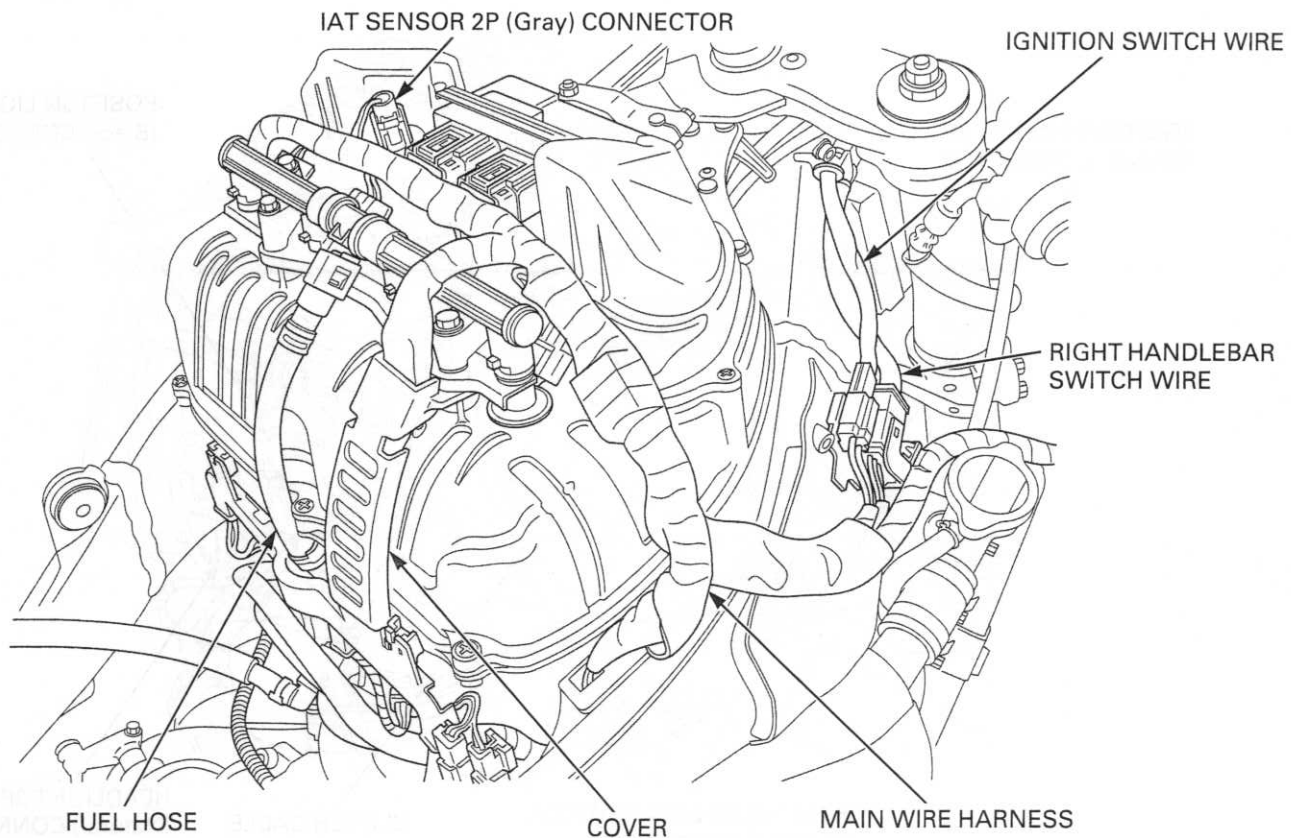
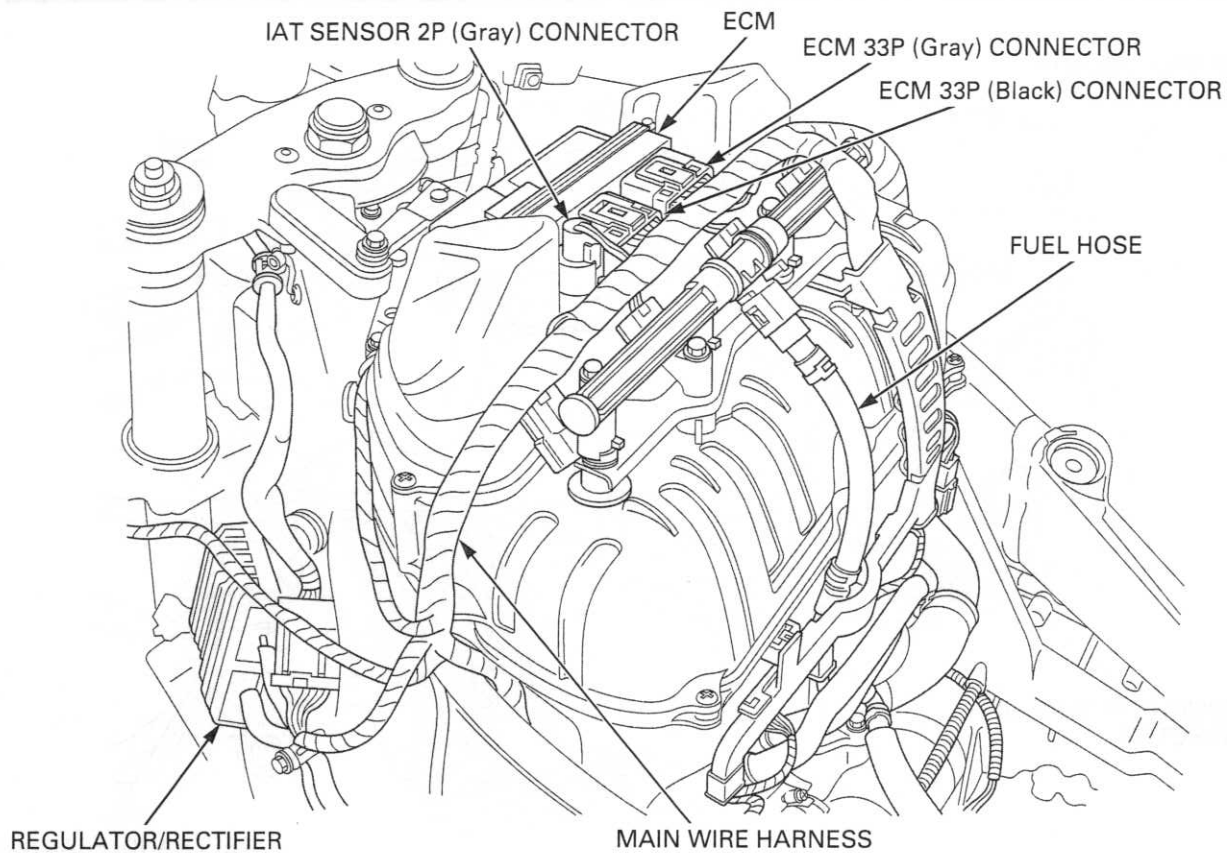

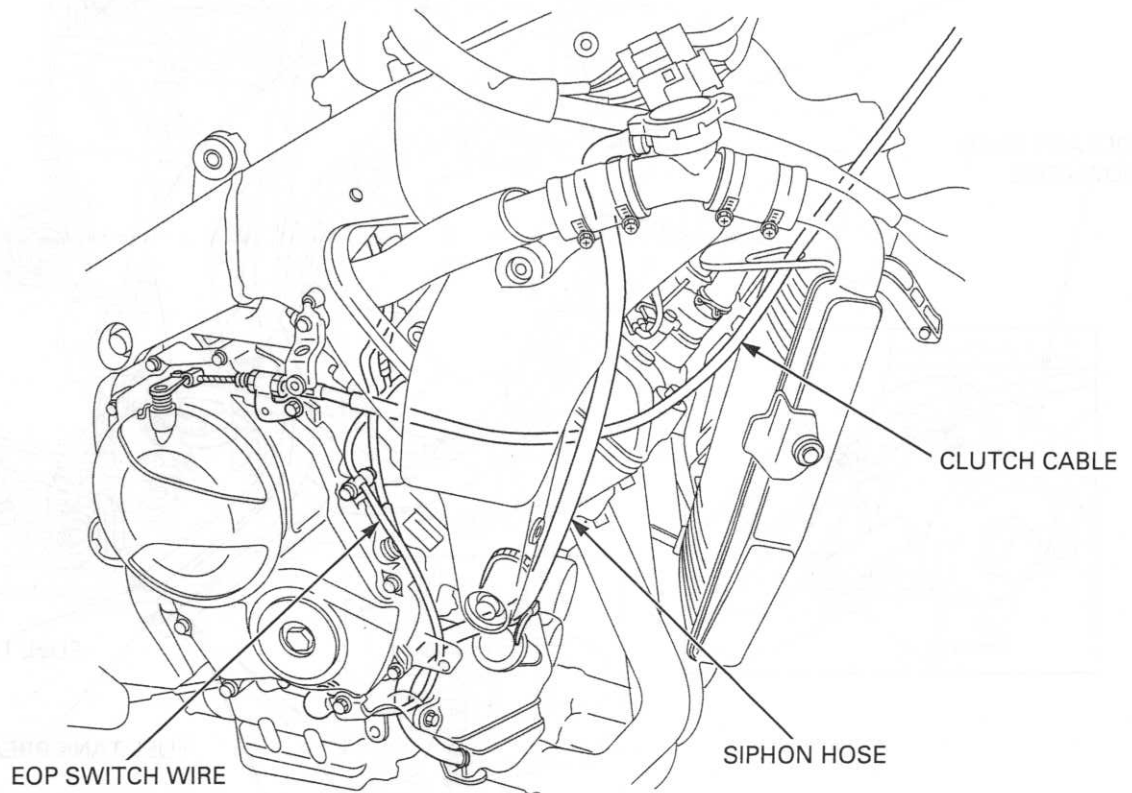
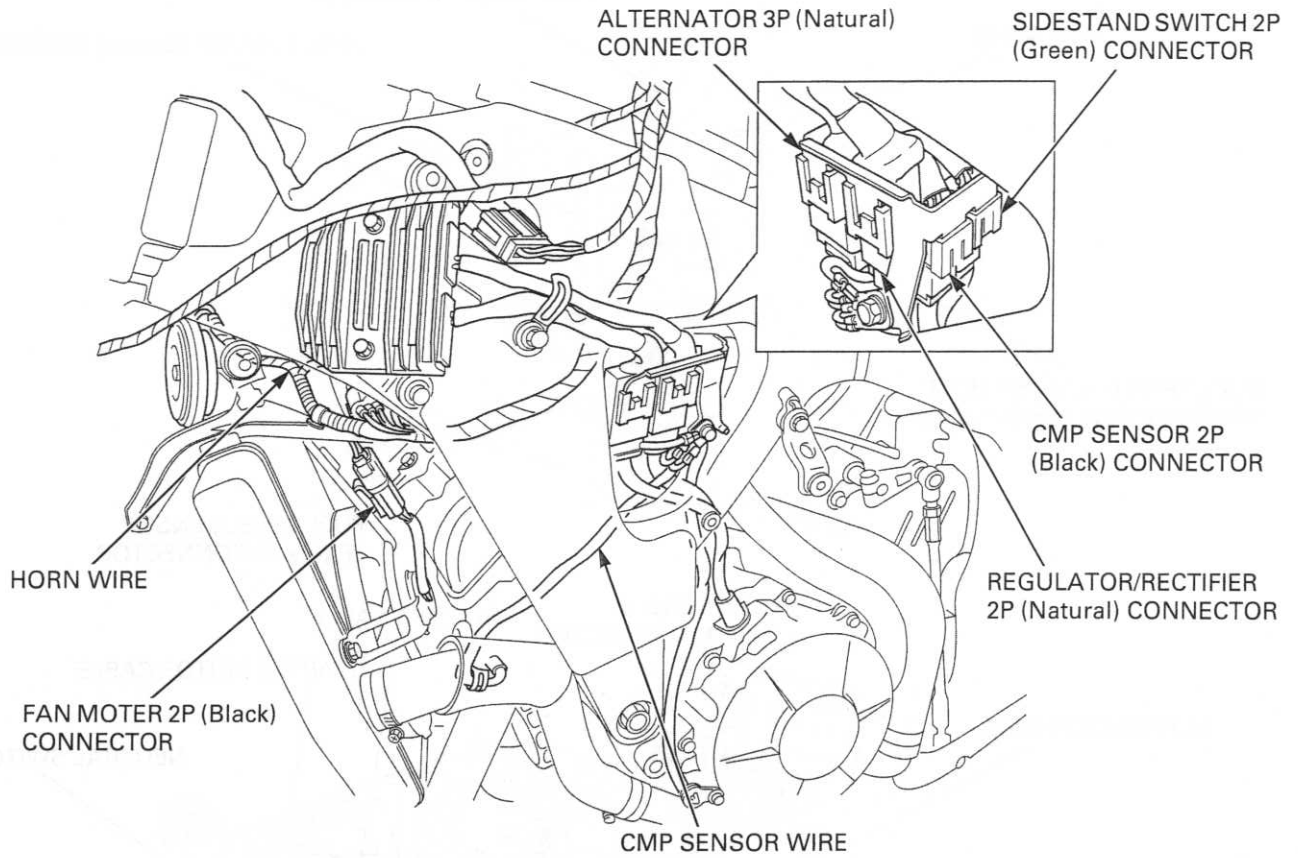

GENERAL INFORMATION

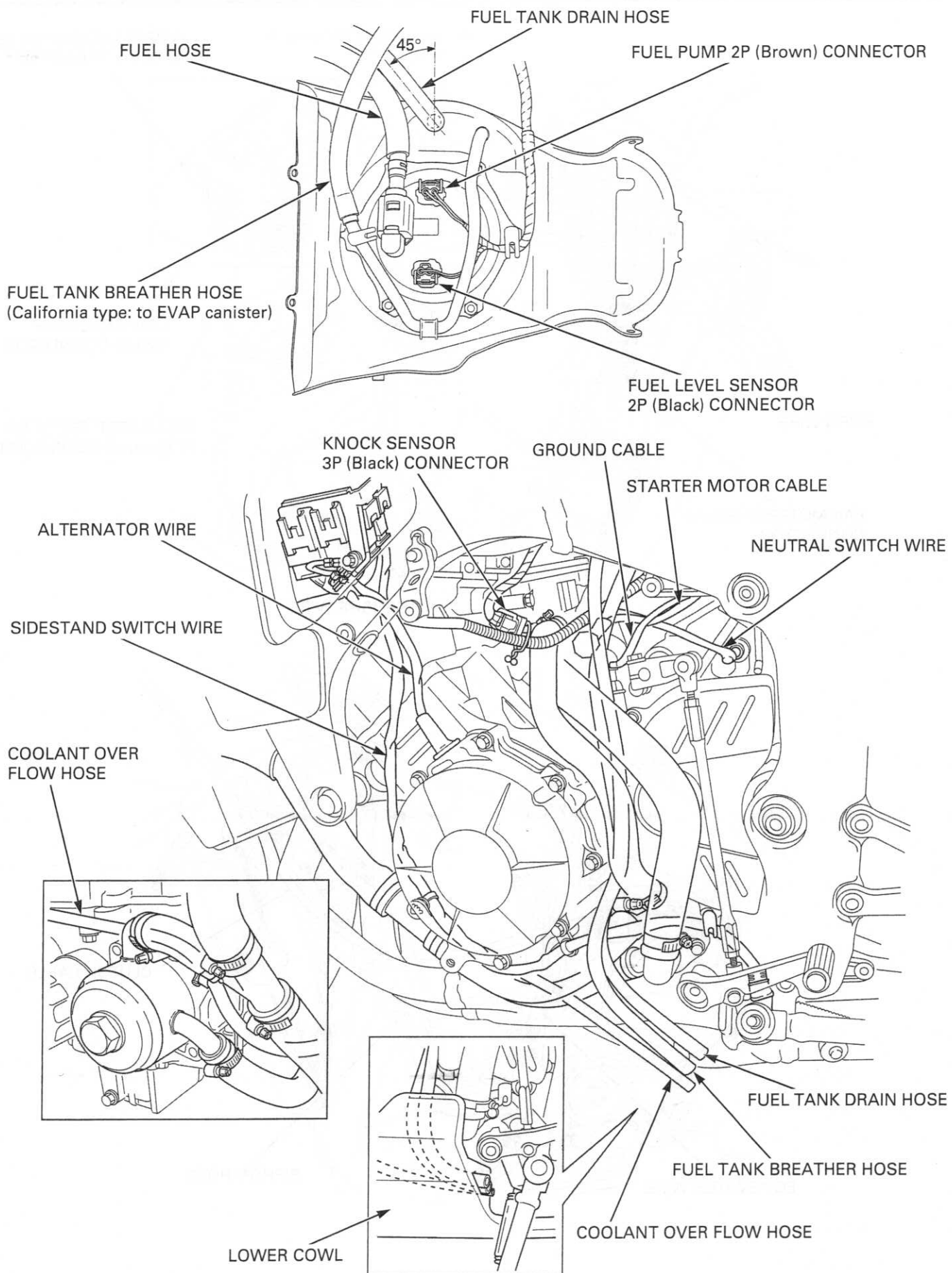

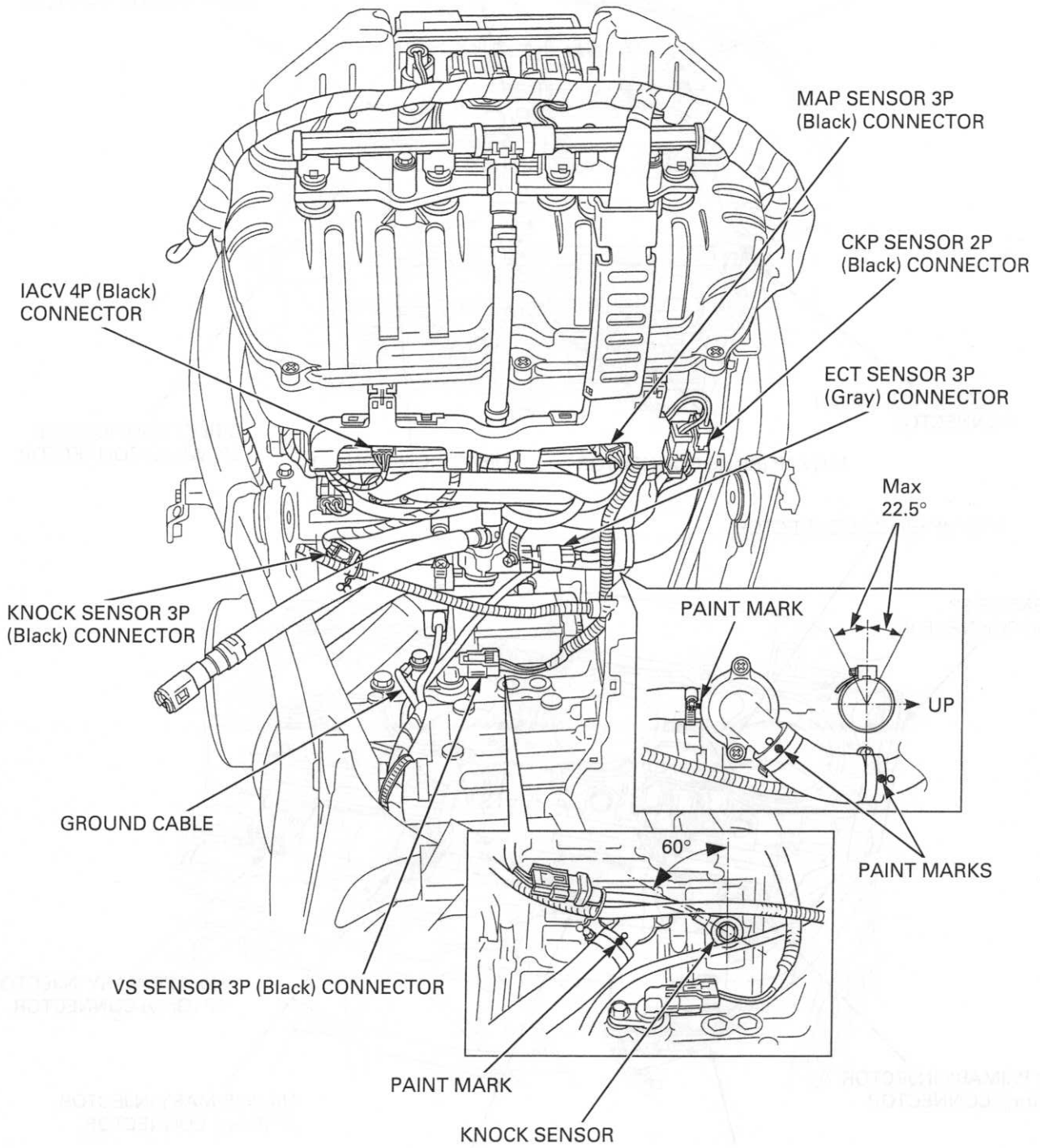

GENERAL INFORMATION

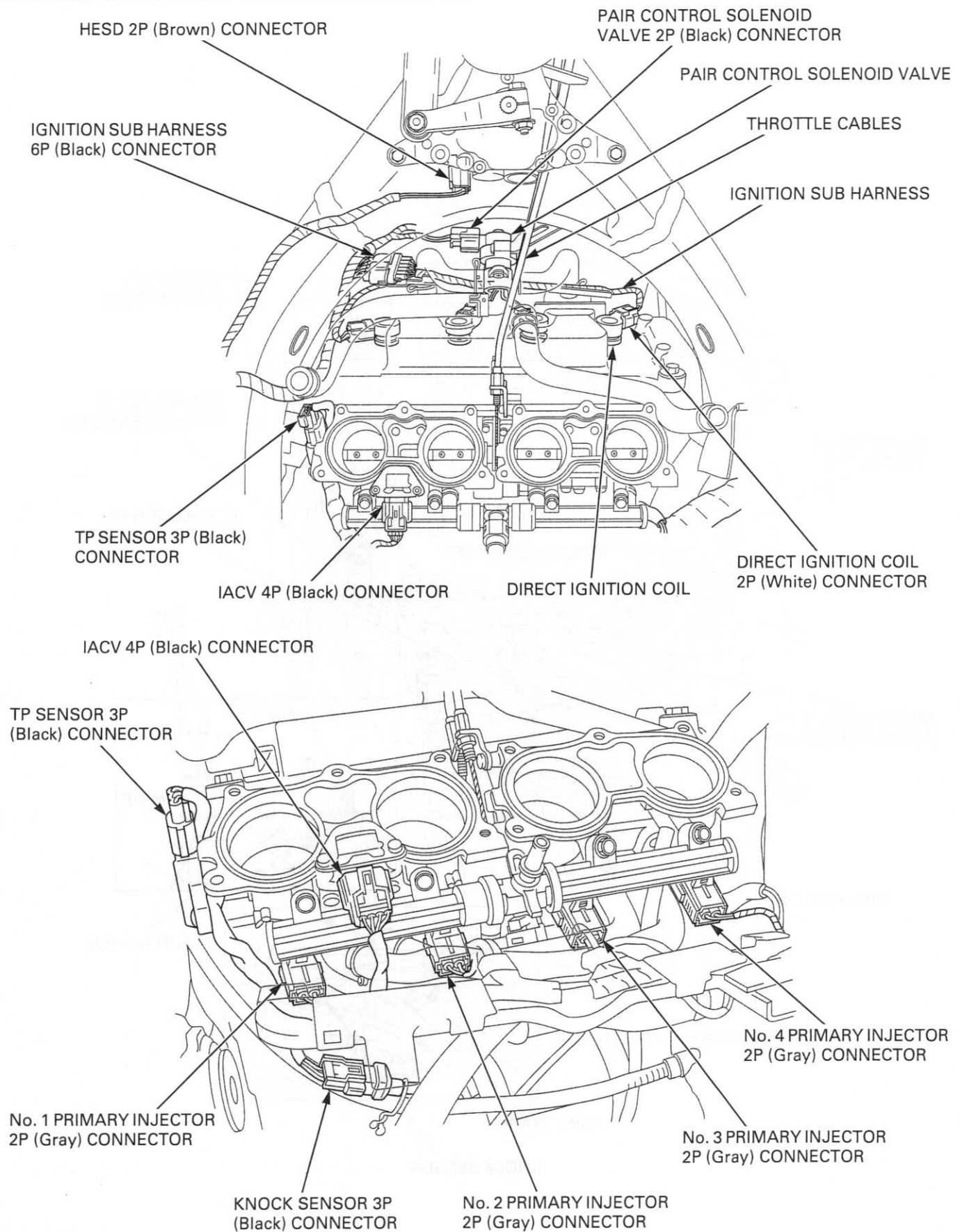

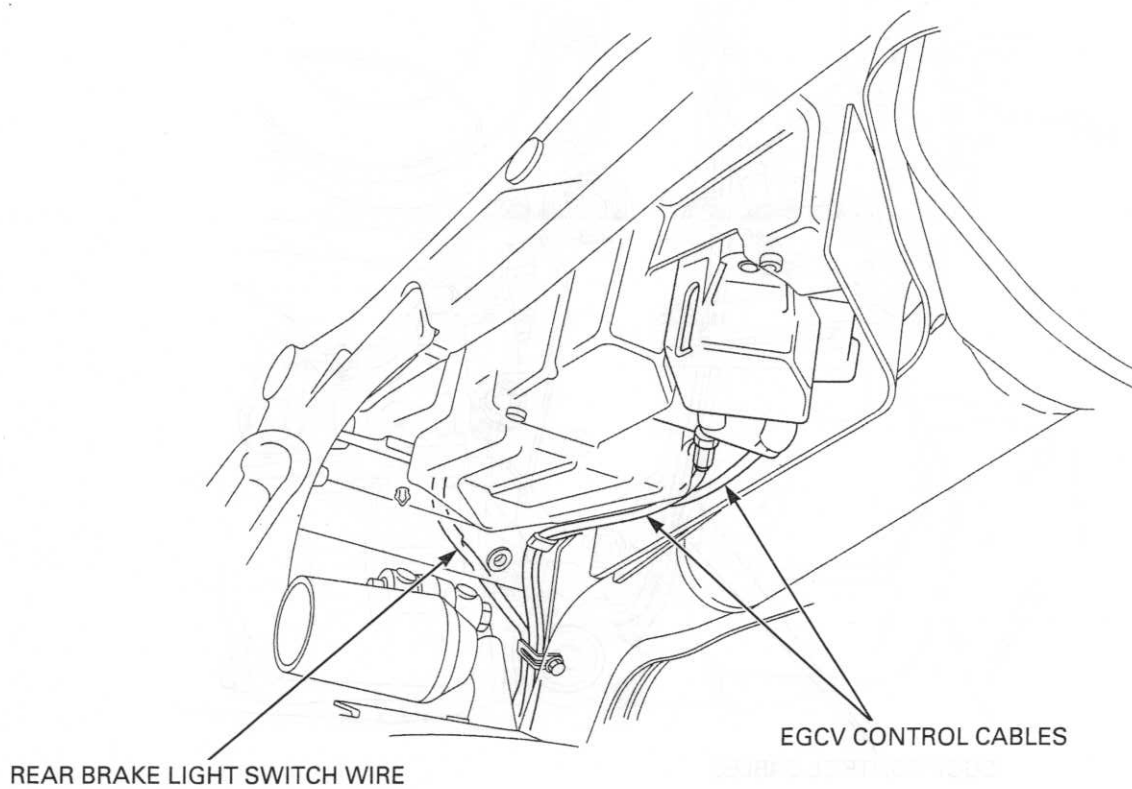
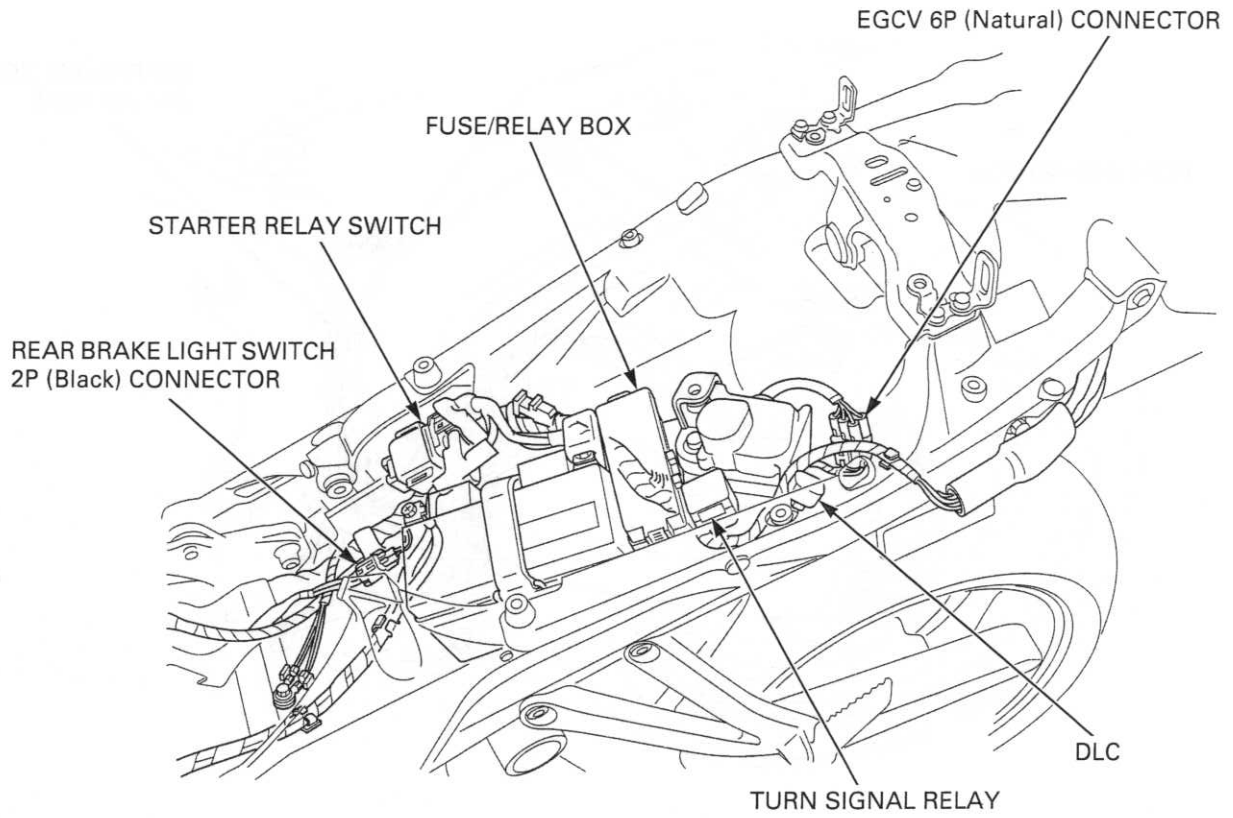

GENERAL INFORMATION

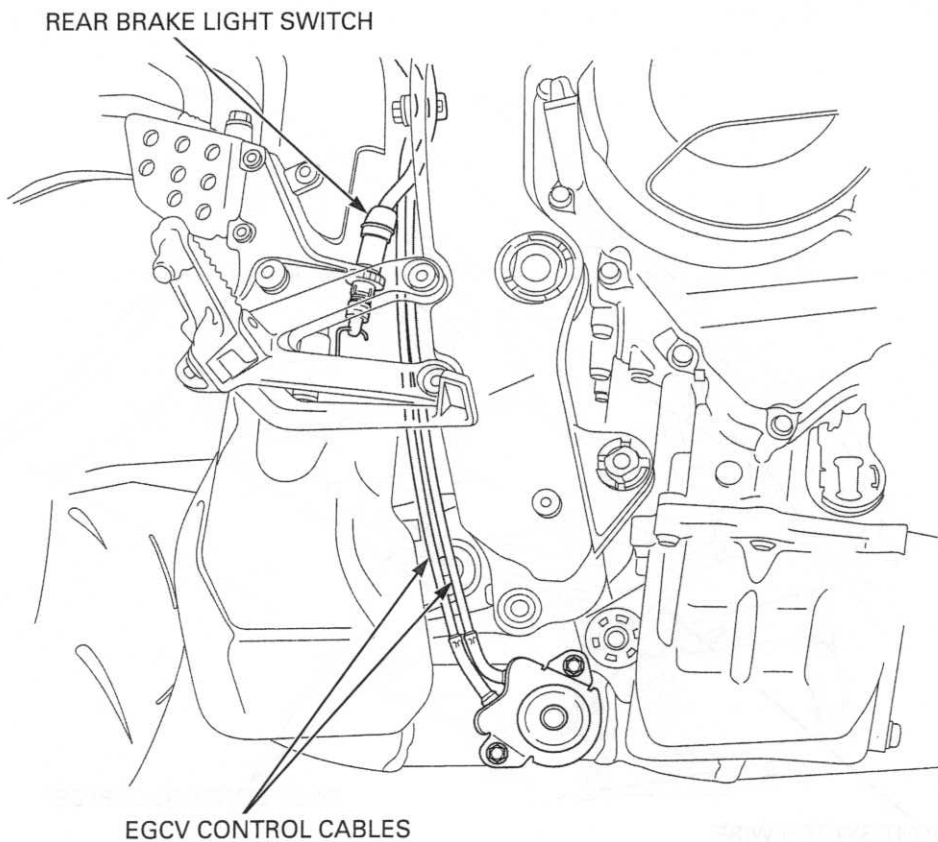
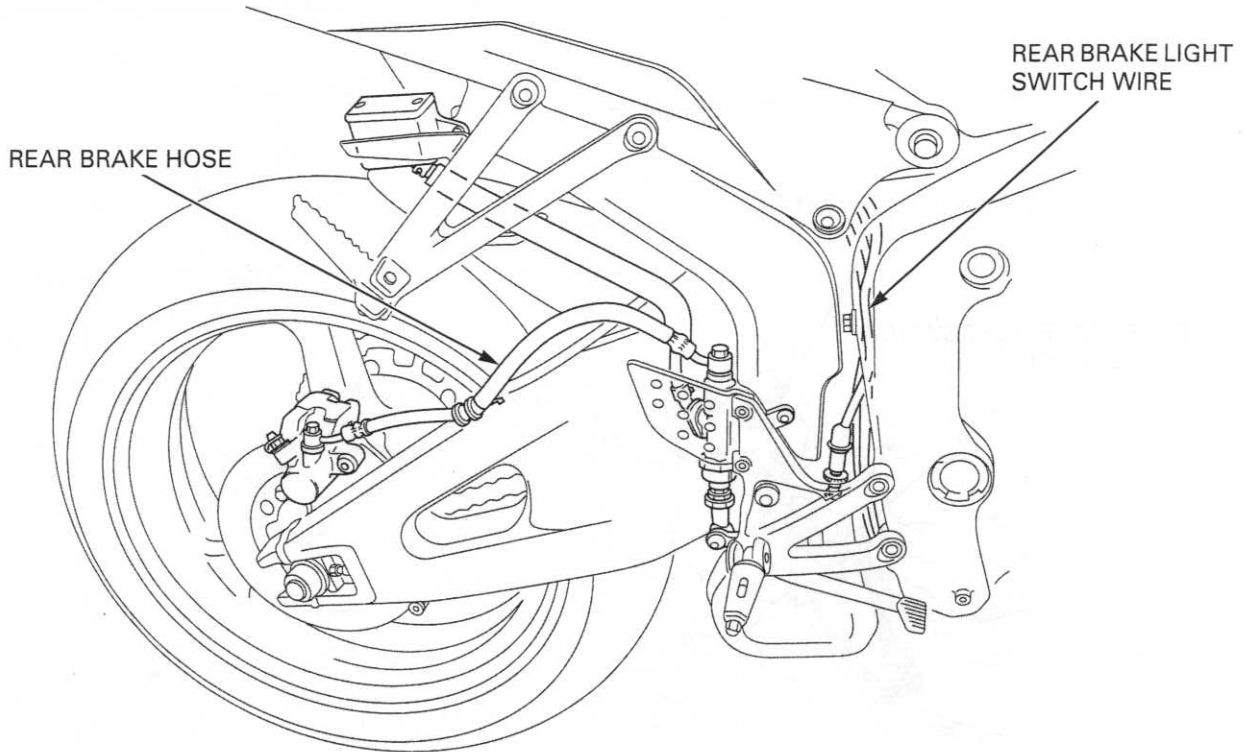

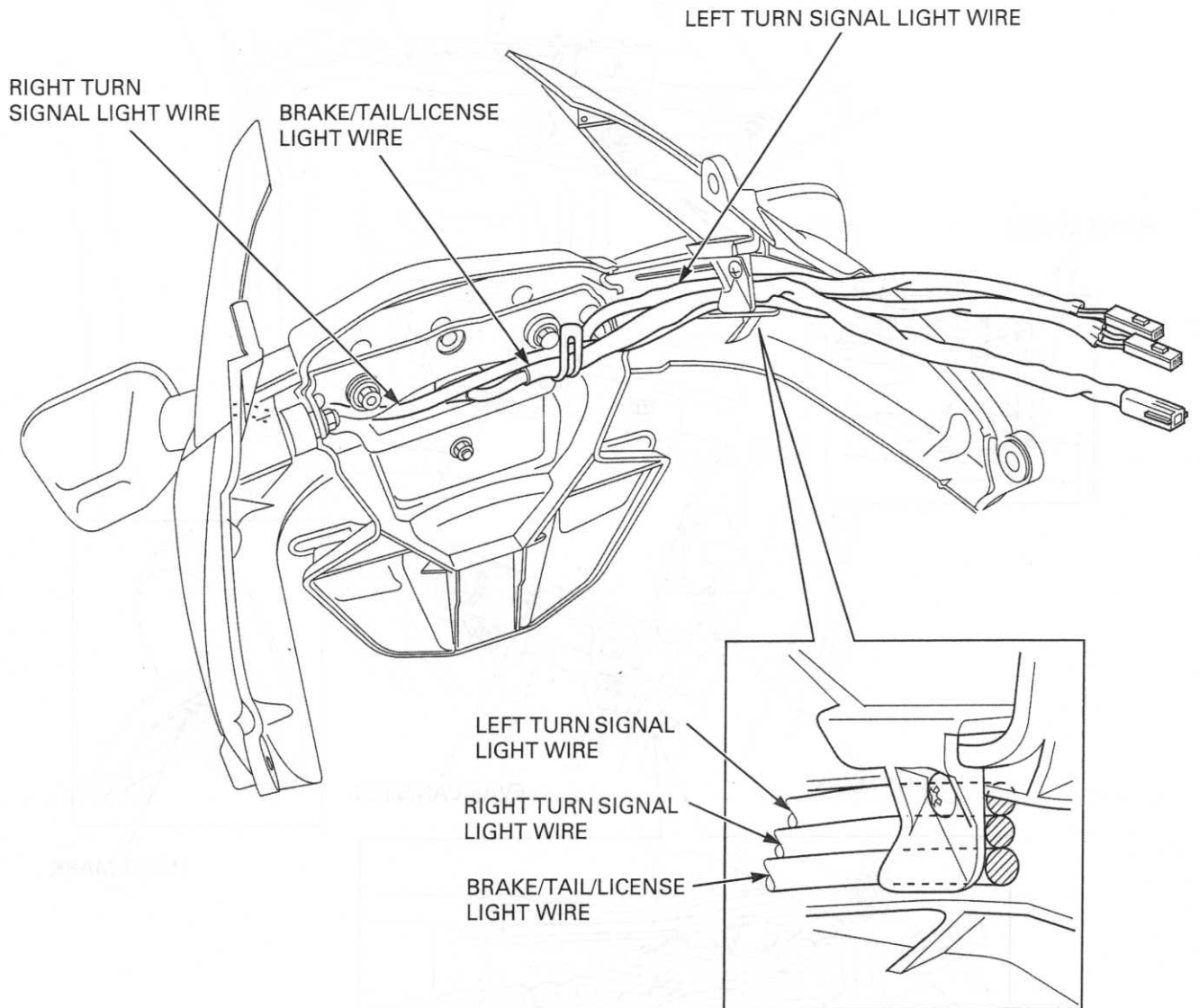

GENERAL INFORMATION

CALIFORNIA TYPE:

NOTE: Face the paint marks upward.

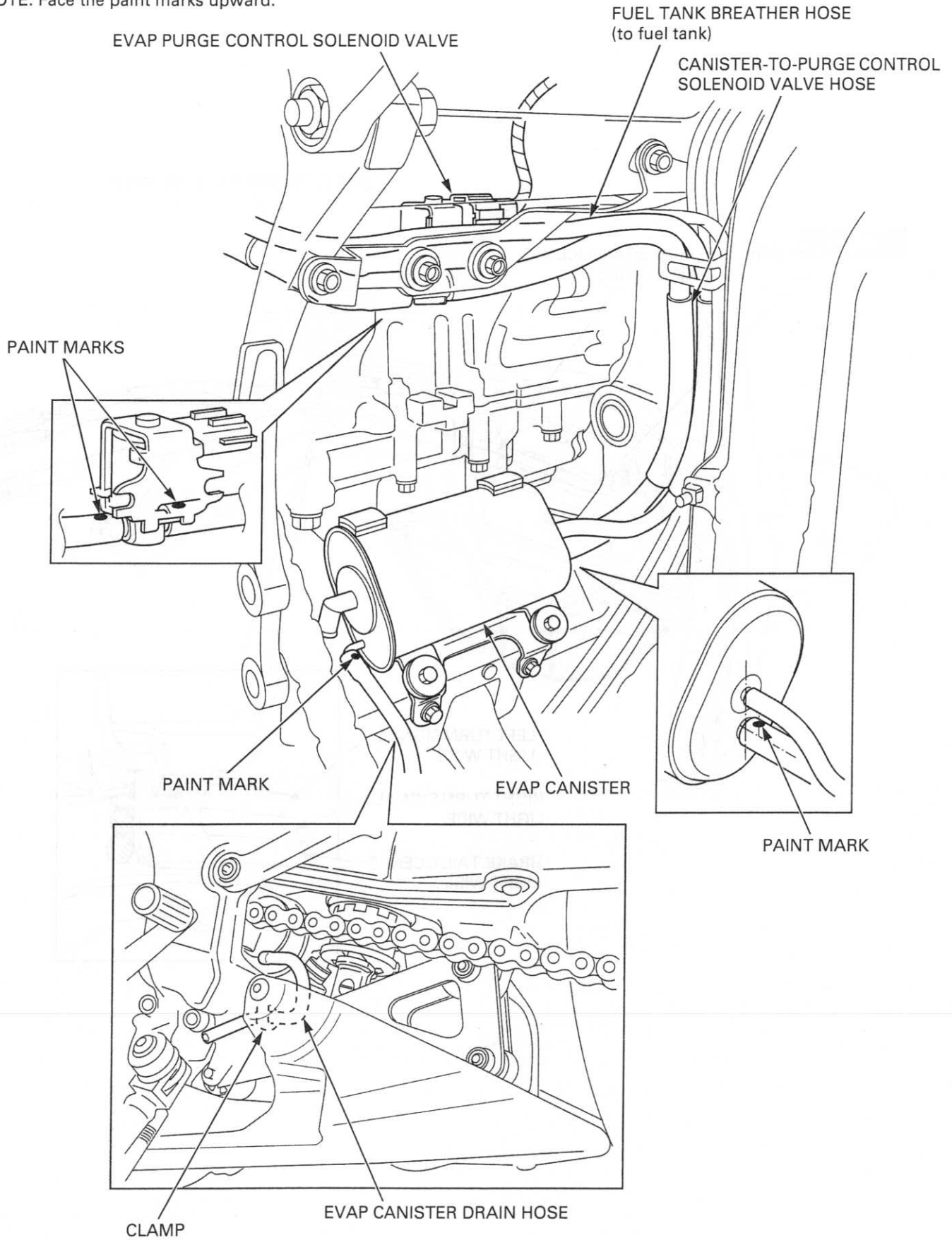

CALIFORNIA TYPE:

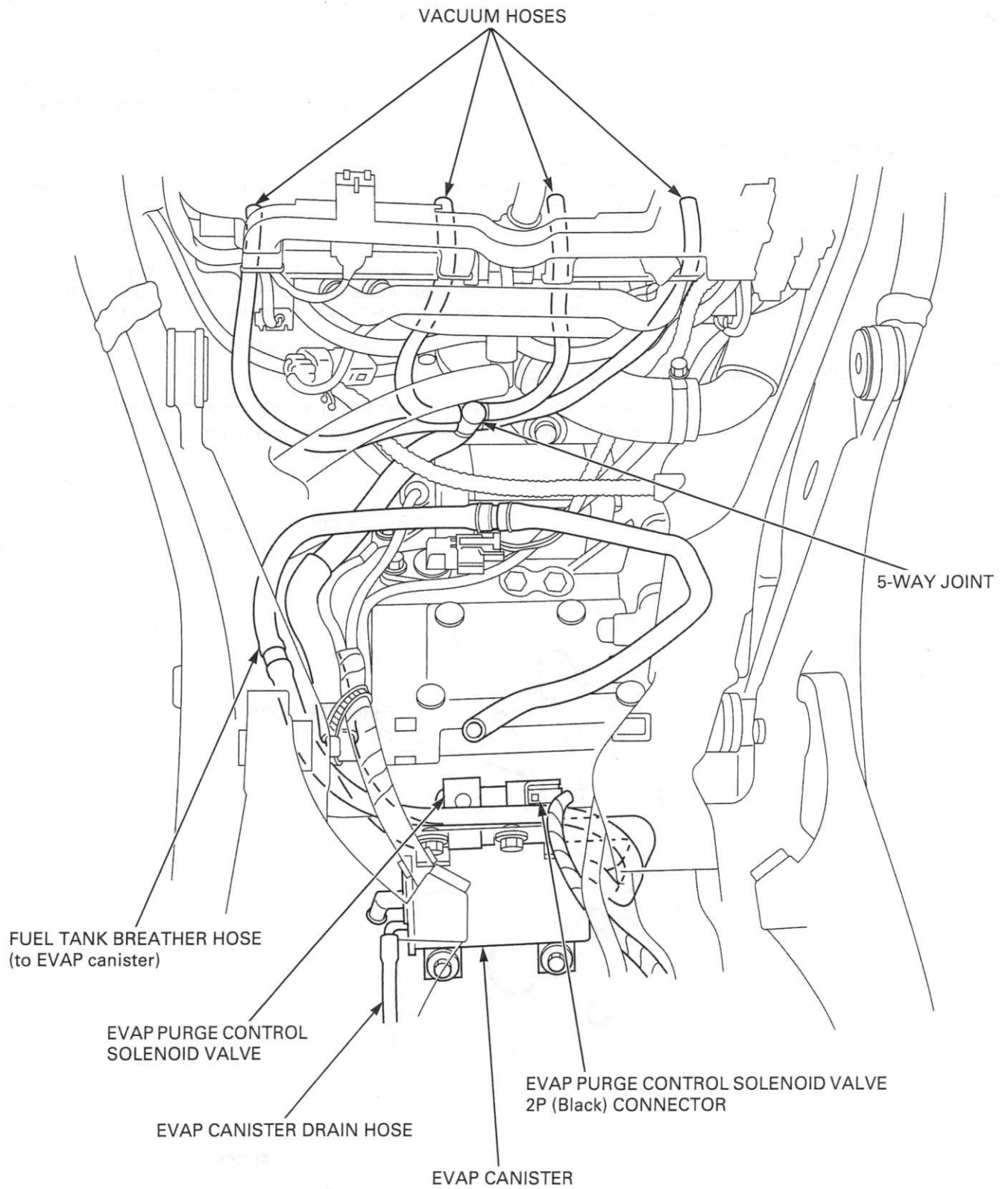

GENERAL INFORMATION

EMISSION CONTROL SYSTEMS

EXHAUST EMISSION REQUIREMENT

The U.S. Environmental Protection Agency (EPA), California Air Resources Board (CARB) and Transport Canada require manufacturers to certify that their motorcycles comply with applicable exhaust emissions standards during their useful life, when operated and maintained according to the instructions provided.

NOISE EMISSION REQUIREMENT

The EPA also requires that motorcycles built after January 1, 1983 comply with applicable noise emission standards for one year or 3,730 miles (6,000 km) after the time of sale to the ultimate purchaser, when operated and maintained according to the instructions provided.

WARRANTY COMPLIANCE

Compliance with the terms of the Distributor's Limited Warranty for Honda Motorcycle Emission Control Systems is necessary in order to keep the emissions system warranty in effect.

SOURCE OF EMISSIONS

The combustion process produces carbon monoxide (CO), oxides of nitrogen (NOx) and hydrocarbons (HC). Control of carbon monoxide, oxides of nitrogen and hydrocarbons is very important because, under certain conditions, they react to form photochemical smog when subject to sunlight. Carbon monoxide does not react in the same way, but it is toxic.

Honda Motor Co., Ltd. utilizes various systems to reduce carbon monoxide and hydrocarbons.

CRANKCASE EMISSION CONTROL SYSTEM

The engine is equipped with a closed crankcase system to prevent discharging crankcase emissions into the atmosphere.

Blow-by gas is returned to the combustion chamber through the air cleaner housing and throttle body.

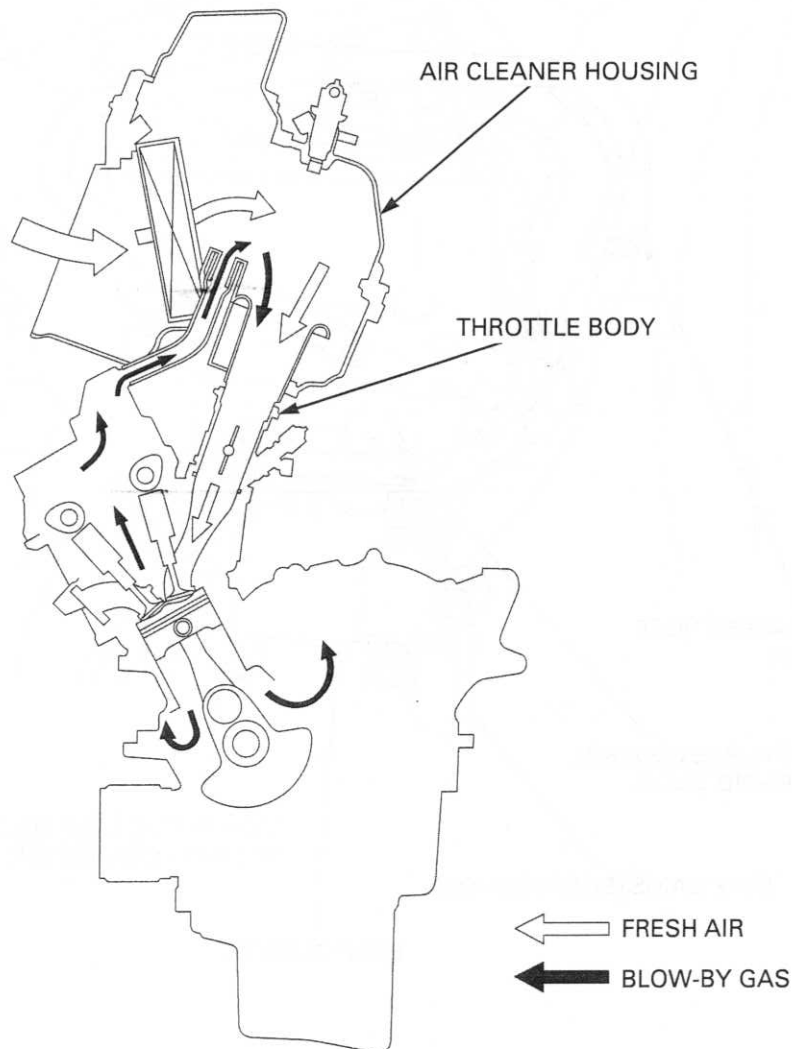

EXHAUST EMISSION CONTROL SYSTEM

The exhaust emission control system is composed of a pulse secondary air supply system, an oxidation catalytic converter and PGM-FI system.

SECONDARY AIR SUPPLY SYSTEM

The pulse secondary air supply system introduces filtered air into the exhaust gases in the exhaust port. Fresh air is drawn into the exhaust port by the function of the PAIR control valve.

This charge of fresh air promotes burning of the unburned exhaust gases and changes a considerable amount of hydrocarbons and carbon monoxide into relatively harmless carbon dioxide and water vapor.

The reed valve prevents reverse air flow through the system. The PAIR control valve is operated by the solenoid valve. The solenoid valve is controlled by the PGM-FI unit, and the fresh air passage is opened/closed according to running conditions (ECT/IAT/TP/MAP sensor and engine revolution).

No adjustments to the secondary air supply system should be made, although periodic inspection of the components is recommended.

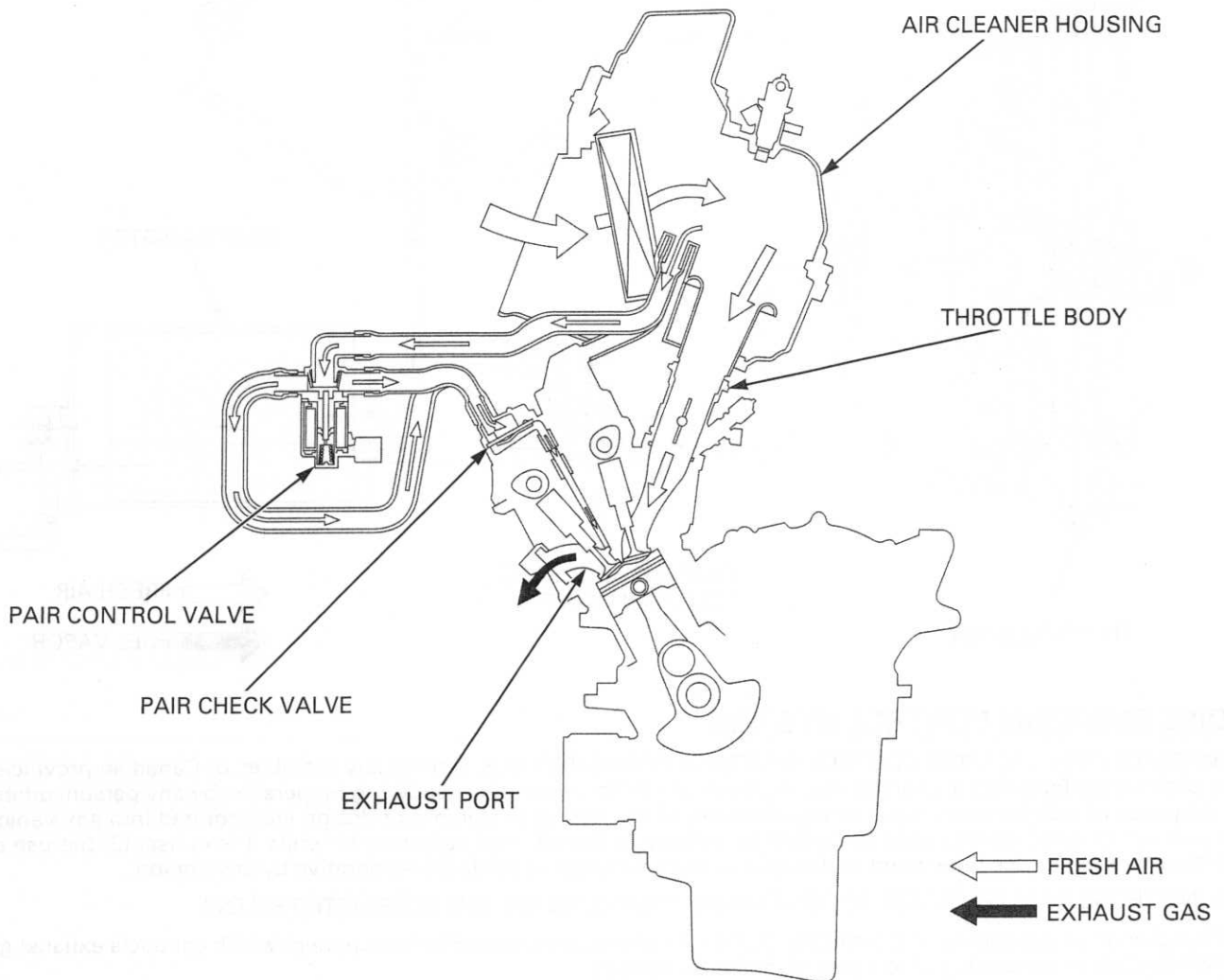

OXIDATION CATALYTIC CONVERTER

This motorcycle is equipped with an oxidation catalytic converter.

The oxidation catalytic converter is in the exhaust system. Through chemical reactions, it converts HC and CO in the engine's exhaust to carbon dioxide (CO₂) and water vapor.

GENERAL INFORMATION

EVAPORATIVE EMISSION CONTROL SYSTEM (CALIFORNIA TYPE)

This model complies with California Air Resources Board (CARB) evaporative emission requirement. Fuel vapor from the fuel tank is routed into the evaporative emission (EVAP) canister where it is absorbed and stored while the engine is stopped. When the engine is running and the evaporative emission (EVAP) purge control solenoid valve is open, fuel vapor in the EVAP canister is drawn into the engine through the throttle body.

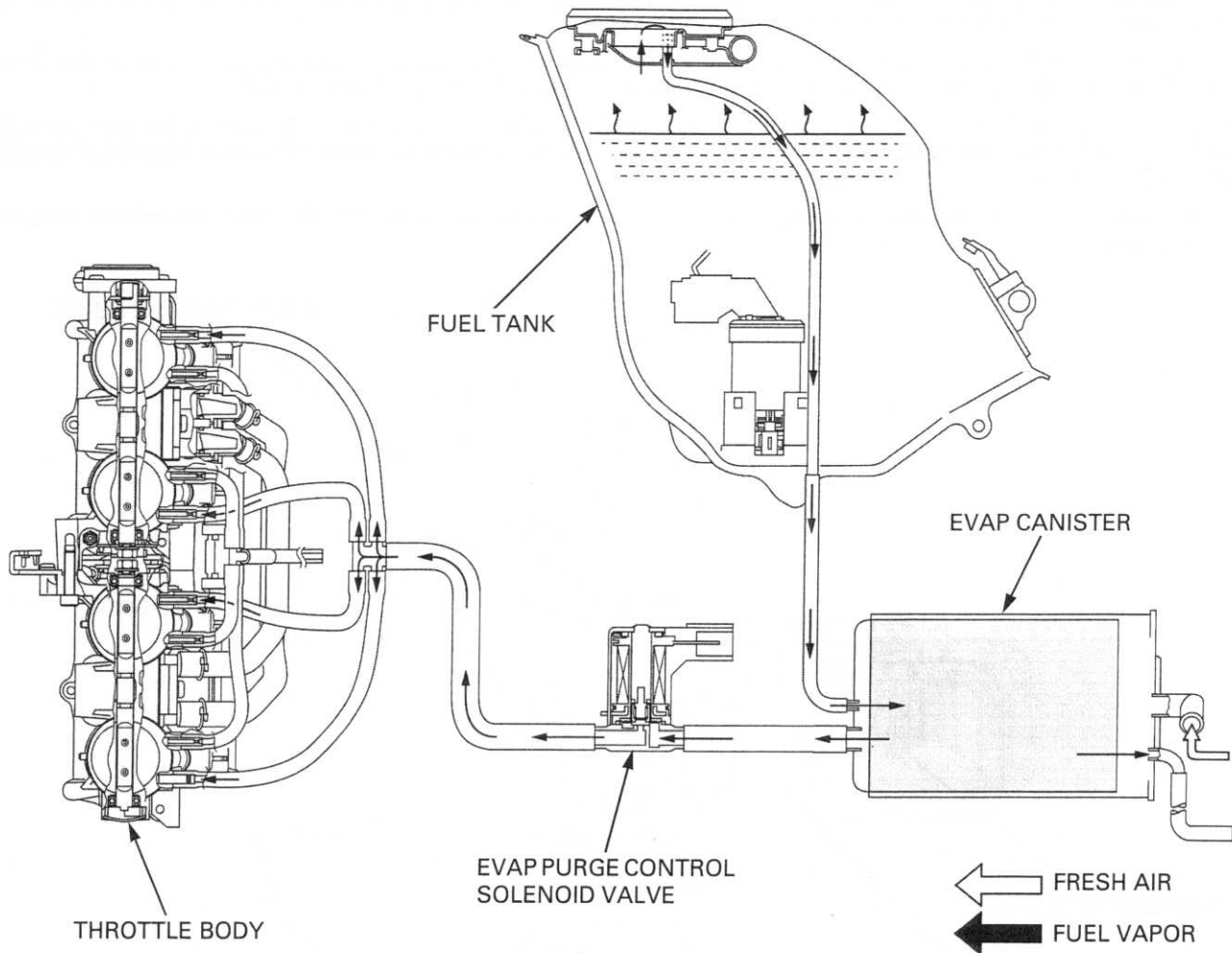

NOISE EMISSION CONTROL SYSTEM

TAMPERING WITH THE NOISE CONTROL SYSTEM IS PROHIBITED: U.S. Federal law prohibits, or Canadian provincial law may prohibit the following acts or the causing there of: (1) The removal or rendering inoperative by any person, other than for purposes of maintenance, repair or replacement, of any device or element of design incorporated into any vehicle for the purpose of noise control prior to its sale or delivery to the ultimate customer or while it is in use; (2) the use of the vehicle after such device or element of design has been removed or rendered inoperative by any person.

AMONG THOSE ACTS PRESUMED TO CONSTITUTE TAMPERING ARE THE ACTS LISTED BELOW:

1. Removal of, or puncturing of the muffler, baffles, header pipes or any other component which conducts exhaust gases.
2. Removal of, or puncturing of any part of the intake system.
3. Lack of proper maintenance.
4. Replacing any moving parts of the vehicle, or parts of the exhaust or intake system, with parts other than those specified by the manufacturer.

2. TECHNICAL FEATURES

IACV..... 2-2

KNOCK SENSOR..... 2-4



TECHNICAL FEATURES

IACV

SUMMARY

This motorcycle adopts an electronic Idle Air Control system for the inline-four engine, this system is composed the IACV and distribution hoses on the throttle body. The IACV consists of a step motor and a slide valve to control the amount of air bypassed around the closed throttle valve. With the ignition switch on, the amount of inlet air is determined from information detected by the ECT sensor. During engine start up or while maintaining idle (throttle valve closed), the amount of inlet air is corrected by various sensors' information.

This system eliminates the need for manual idle speed adjustment and air screw adjustment for throttle body synchronization.

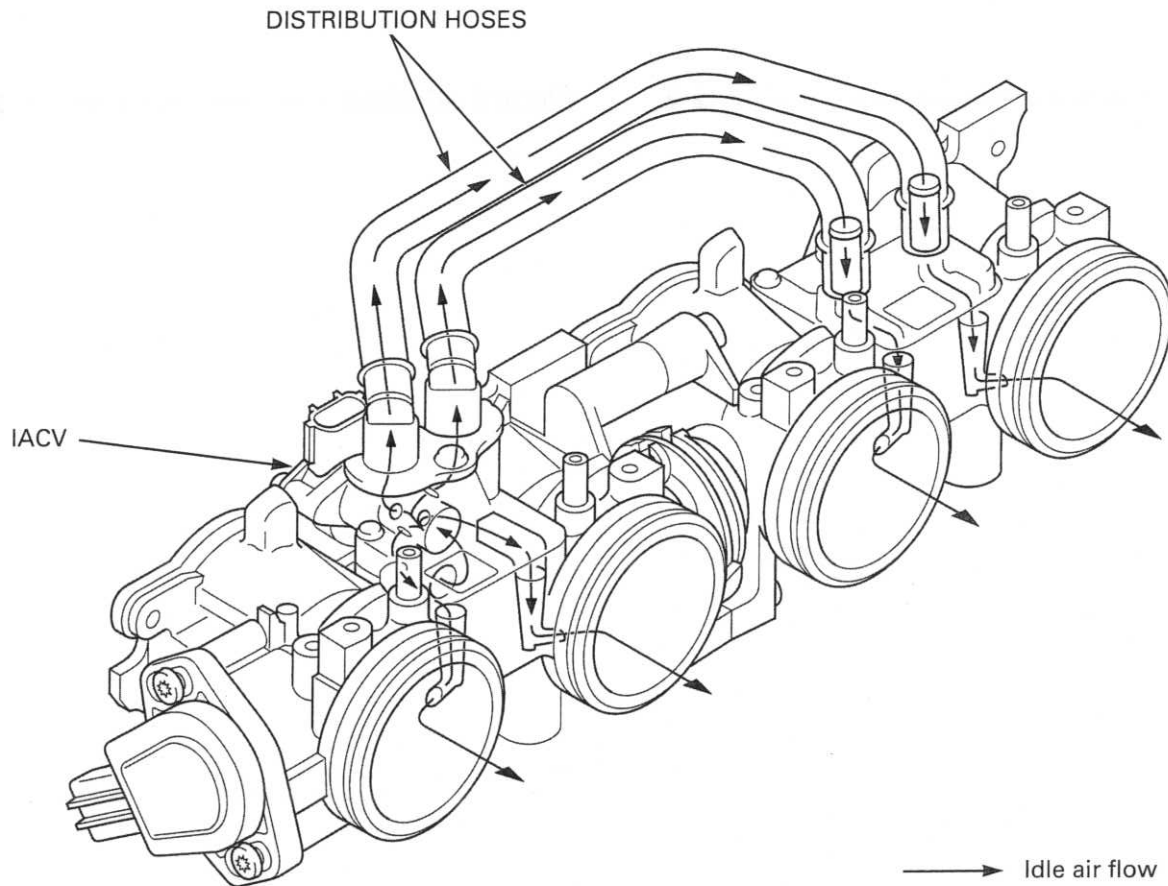

OPERATION

The ECM controls the IACV during engine idling, also the ECM stops controlling the IACV operation and closes the valve when the ECM detects the following conditions:

- Throttle valve open
- Neutral switch OFF (in gear) and clutch switch OFF (release clutch lever)

During engine idling, from ignition switch ON to warming up, the ECM controls the IACV step motor as follows:

With the ignition switch ON

When the ignition switch is turned ON, the IACV activates initial function, idle – open – idle position. There will be a step motor operating sound.

Engine start – warming up

This optimizes the bypass opening with the throttle valve closed, and the correct amount of inlet air passes through, allowing proper engine start up.

After the engine has started, the ECM controls the IACV slide valve position and adjusts the amount of inlet air in response to the engine coolant temperature.

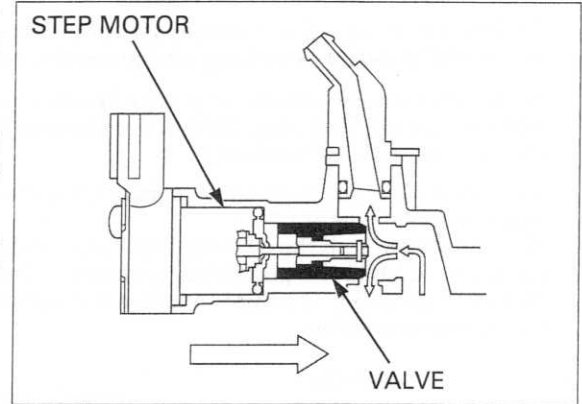

After warming up – idling

When the ECM denotes the engine warming up by the engine coolant temperature, it operates the step motor to move the slide valve to the closed position. This results in a reduced amount of bypassed air compared to the amount during engine warm-up, which allows proper engine idle to be maintained.

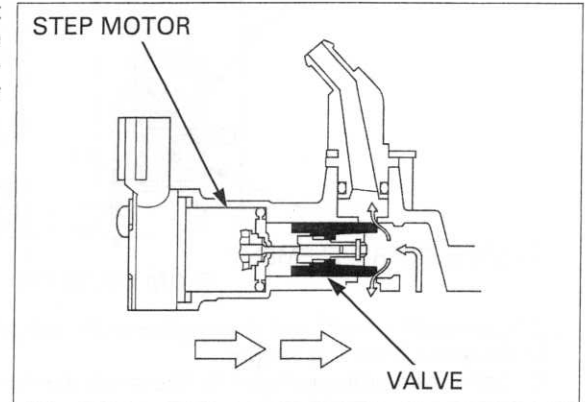

TECHNICAL FEATURES

KNOCK SENSOR

SUMMARY

Under certain conditions the mixture in the perimeter of the combustion chamber can self-ignite due to the expansion of the combusting gas ignited by the spark plug. At this point there are two flame-fronts colliding within the combustion chamber.

As a result, the pressure and temperature in the cylinder increase at a time different from normal-combustion conditions, causing damage to the piston and/or the combustion chamber. Such a phenomenon is called knocking.

Deteriorated or low-octane gasoline may cause the knocking more frequently, resulting in engine damage.

To detect knocking, the knock sensor is attached in the rear of No.3 cylinder block. Monitoring signals from the knock sensor, the ECM detects knocking, and prevents engine damage by regulating ignition timing.

In this model, a non-resonating type knock sensor is employed. With the voltage signals free of resonant characteristics and the convergence period short, the responsiveness is superb, the knocking signals do not overlap in the high rpm zone, allowing detection of knocking.

The non-resonating type knock sensor consists of the base, which is mounted on the cylinder block, the weight, and the piezoelectric element.

The vibrations from the cylinder block are directly transmitted to the base. The weight applies the pressure occurring from its inertia force to the piezoelectric element. The pressure is converted to voltage by the piezoelectric element, and transmitted to the ECM. The ECM modifies the voltage signal waveform, separates knocking signals from engine noise signals, and detects knocking.

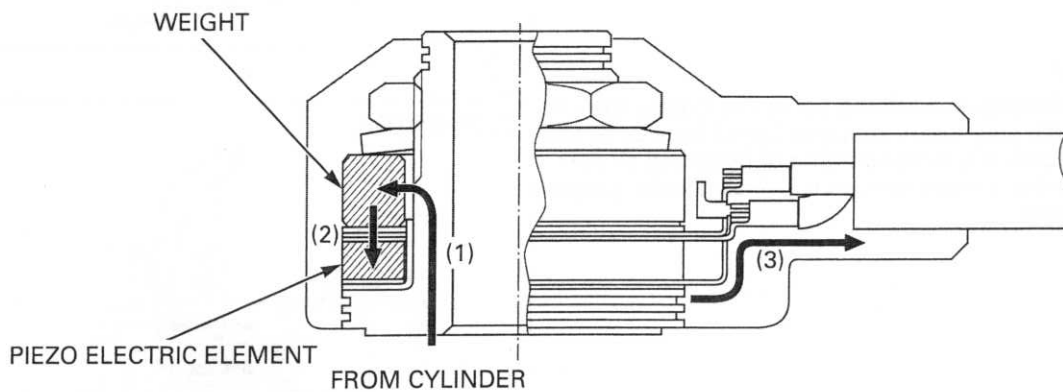

- (1) Conveying motion of the engine to the weight
- (2) Pressure from the weight
- (3) Converted voltage signal by the piezo electric element

When the ECM determines that the voltage signal is higher than the prescribed level (knock occurring), it retards the ignition timing. When the ECM determines that the voltage signal is lower than the prescribed level (no knocking) during the retarded ignition timing period, it gradually advances the ignition timing back to normal.

The ECM has self-diagnostic functions for the knock sensor circuit. It can detect a sensor output line short, failure of the integrated circuit (IC) within the ECM, and a connector coming off.

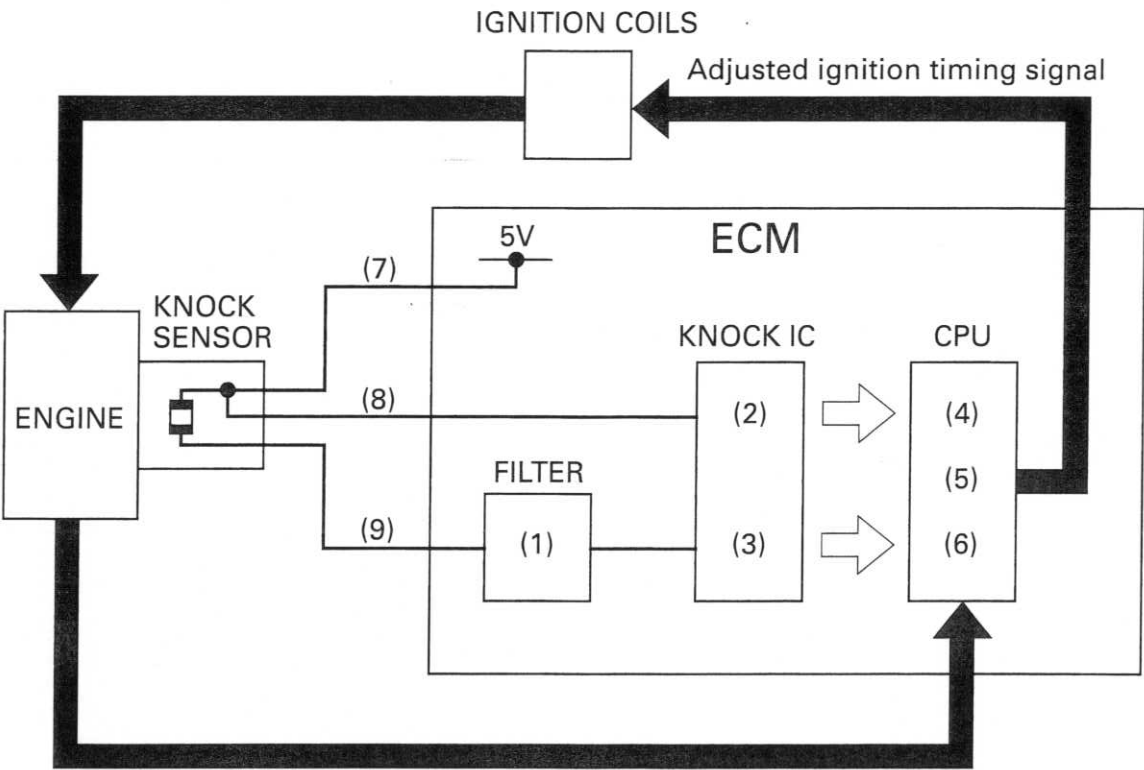

ECM monitors engine condition through PGM-FI sensors (ECT ,MAP ,TP sensor etc...)

- (1) Regulate the input voltage signal wave
- (2) Noise signal pick up circuit
- (3) Knock signal pick up circuit
- (4) Detect the knock
- (5) Calculate proper ignition timing
- (6) Detect the fail safe
- (7) Input voltage line (for open circuit detection)
- (8) Open circuit detection line
- (9) Output voltage line

MEMO



Internal ROM-R1 component (Q1) layout

- (1) Input voltage line
- (2) Output voltage line
- (3) Output current line
- (4) Input current line
- (5) Input voltage line
- (6) Output voltage line
- (7) Output current line
- (8) Input current line

3. FRAME/BODY PANELS/EXHAUST SYSTEM

BODY PANEL LOCATIONS	3-2	REARVIEW MIRROR	3-10
SERVICE INFORMATION	3-3	WINDSCREEN	3-10
TROUBLESHOOTING	3-3	UPPER COWL/FRONT SPOILER	3-11
SEAT	3-4	AIR DUCT	3-12
PASSENGER SEAT	3-4	FRONT FENDER	3-13
REAR COWL	3-5	REAR FENDER A	3-13
LOWER COWL	3-6	REAR FENDER B	3-14
UPPER INNER COWL/HEADLIGHT COVER	3-7	REAR FENDER C	3-16
MIDDLE COWL	3-8	SEAT RAIL	3-16
FUEL TANK COVER/SIDE COVER	3-9	MUFFLER	3-19
		EXHAUST PIPE	3-24

BODY PANEL LOCATIONS

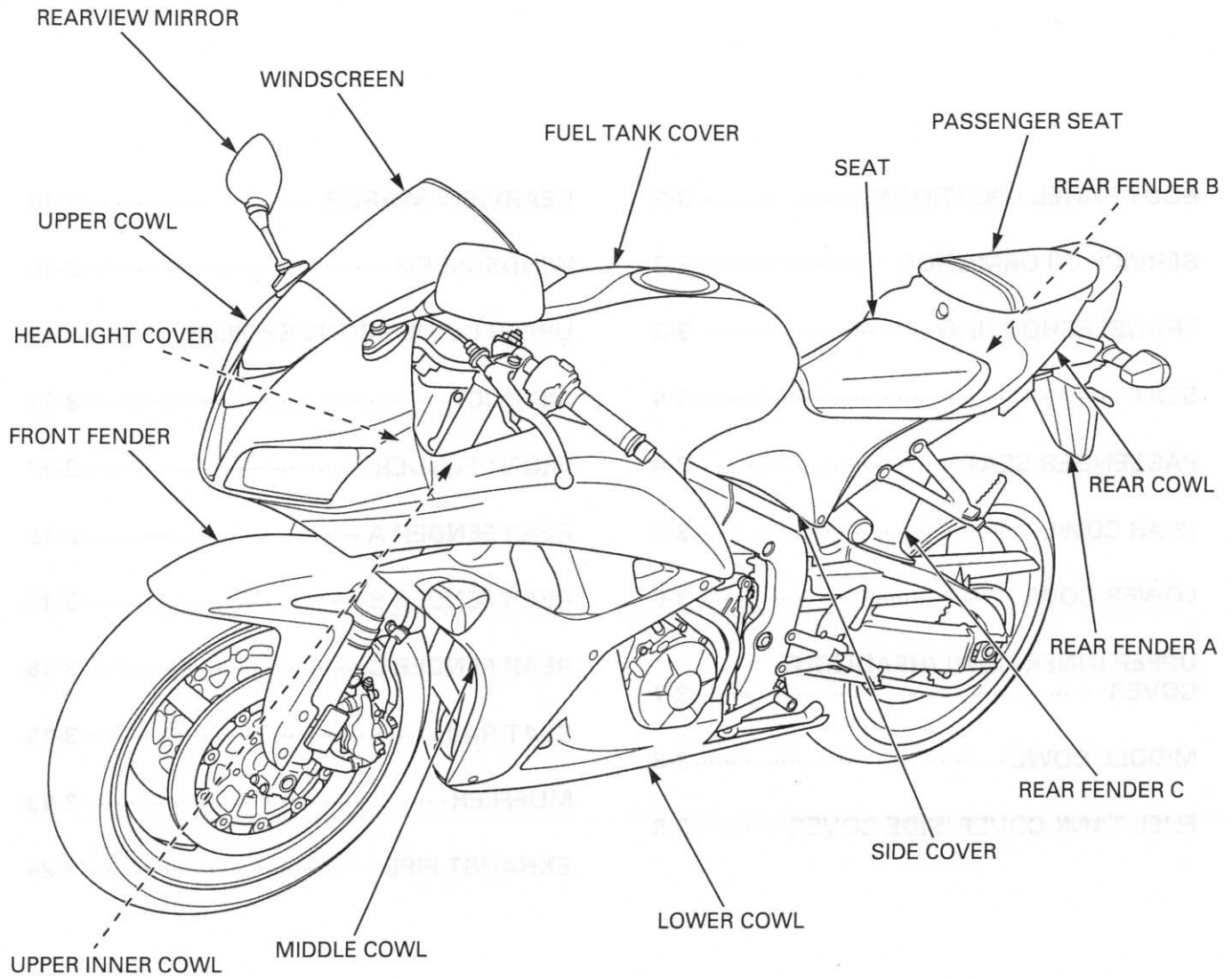

SERVICE INFORMATION

GENERAL

- This section covers removal and installation of the body panels, exhaust system and seat rail.
- Serious burns may result if the exhaust system is not allowed to cool before components are removed or serviced.
- Always replace the exhaust pipe gaskets with new ones after removing the exhaust pipe from the engine.
- When installing the exhaust system, loosely install all of the exhaust pipe fasteners. Always tighten the exhaust clamps first, then tighten the mounting fasteners.
- Always inspect the exhaust system for leaks after installation.

TORQUE VALUES

Lower cowl-to-middle cowl screw	1.5 N·m (0.2 kgf·m, 1.1 lbf·ft)
Rearview mirror mounting bolt	7.0 N·m (0.7 kgf·m, 5.2 lbf·ft)
Windscreen mounting screw	0.45 N·m (0.05 kgf·m, 0.3 lbf·ft)
Front brake hose clamp nut	10 N·m (1.0 kgf·m, 7 lbf·ft)
Front brake hose 3-way joint bolt	10 N·m (1.0 kgf·m, 7 lbf·ft)
Front fender mounting screw	12 N·m (1.2 kgf·m, 9 lbf·ft)
Seat rail mounting nut	54 N·m (5.5 kgf·m, 40 lbf·ft)
Seat rail mounting bolt	44 N·m (4.5 kgf·m, 32 lbf·ft)
Seat rail assembly bolt	30 N·m (3.1 kgf·m, 22 lbf·ft)
Exhaust pipe joint nut	12 N·m (1.2 kgf·m, 9 lbf·ft)
Exhaust pipe mounting bolt	17 N·m (1.7 kgf·m, 13 lbf·ft)
Main step bracket mounting bolt	37 N·m (3.8 kgf·m, 27 lbf·ft)
Passenger step bracket mounting bolt	26 N·m (2.7 kgf·m, 19 lbf·ft)
Rear master cylinder mounting bolt	12 N·m (1.2 kgf·m, 9 lbf·ft)
Position light mounting screw	1.8 N·m (0.2 kgf·m, 1.3 lbf·ft)
Rear fender bracket mounting bolt	12 N·m (1.2 kgf·m, 9 lbf·ft)
Muffler band bolt	17 N·m (1.7 kgf·m, 13 lbf·ft)
Air duct mounting bolt	12 N·m (1.2 kgf·m, 9 lbf·ft)

ALOC bolt; replace with a new one

TROUBLESHOOTING

Excessive exhaust noise

- Broken exhaust system
- Exhaust gas leak

Poor performance

- Deformed exhaust system
- Exhaust gas leak
- Clogged muffler

SEAT

REMOVAL/INSTALLATION

Remove the screws, washers and seat rearward.
Install the seat by inserting the prong and aligning its holes with the seat rail bosses.
Tighten the screws securely.

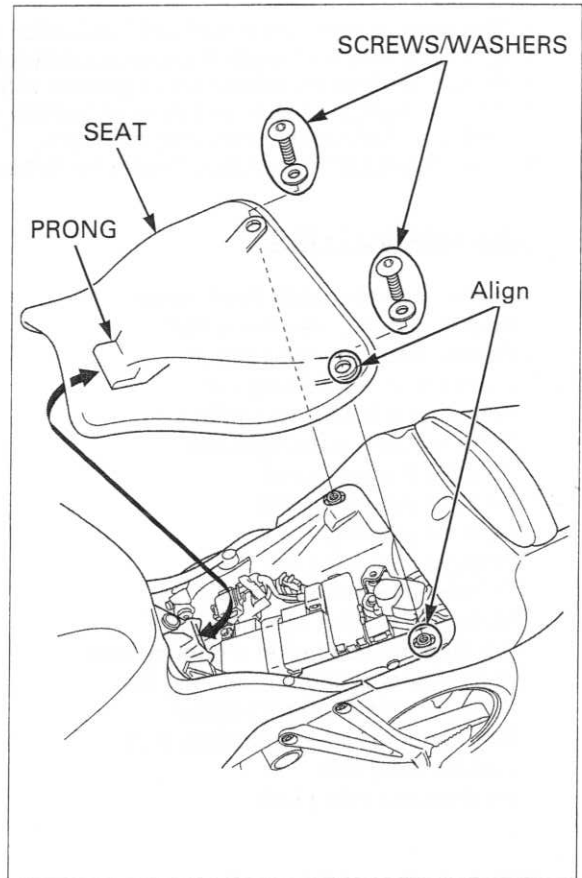

PASSENGER SEAT

REMOVAL/INSTALLATION

Unhook the passenger seat lock using the ignition key.
Remove the passenger seat by pulling it forward.
Install the passenger seat in the reverse order of removal and push down it to lock.

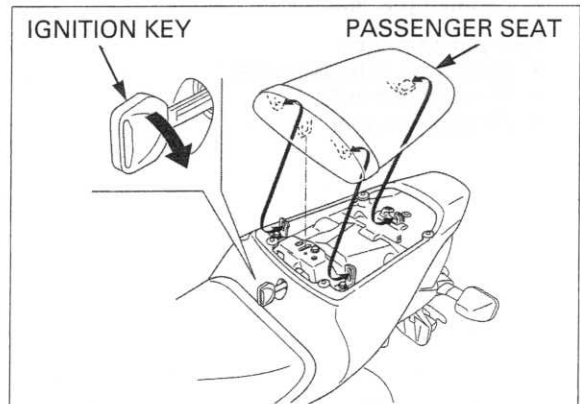

REAR COWL

REMOVAL/INSTALLATION

Remove the following:

- Seat (page 3-4)
- Passenger seat (page 3-4)

Remove the screws, special screws and rear cowl upward.

Installation is in the reverse order of removal.

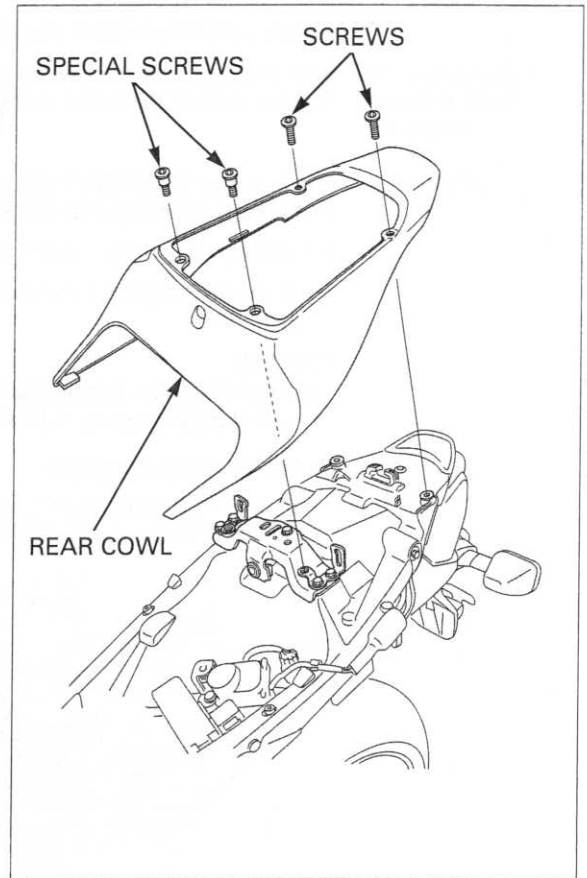

LOWER COWL

REMOVAL/INSTALLATION

Remove the lower cowl-to-middle cowl screws.

Release the hoses from the lower cowl.

Be careful not to damage the tabs and grooves. Remove the lower cowl screw, collar and special screws then remove the lower cowl downward.

California type: Remove the lower cowl screw, collar, special screws and clamp then remove the lower cowl downward.

Installation is in the reverse order of removal.

- Align the middle cowl tabs with the lower cowl grooves.

TORQUE:

Lower cowl-to-middle cowl screw:
1.5 N·m (0.2 kgf·m, 1.1 lbf·ft)

Route the hoses properly:

- Except California type (page 1-21)
- California type (page 1-34)

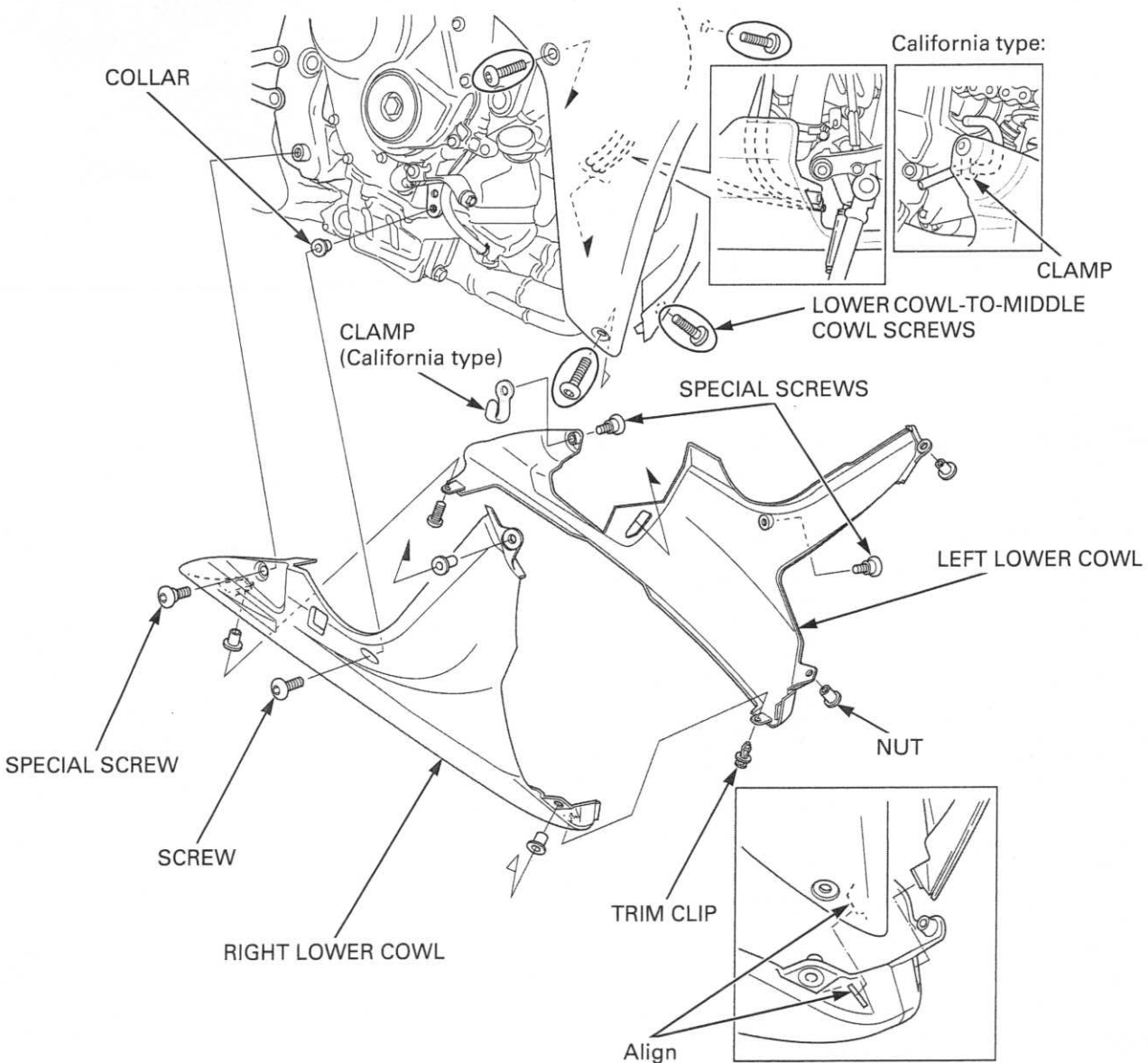

UPPER INNER COWL/HEADLIGHT COVER

REMOVAL/INSTALLATION

Remove the middle cowl (page 3-8).

Remove the trim clips and upper inner cowl.

Remove the screw and headlight cover.

Installation is in the reverse order of removal.

*Route the wires properly
(page 1-21).*

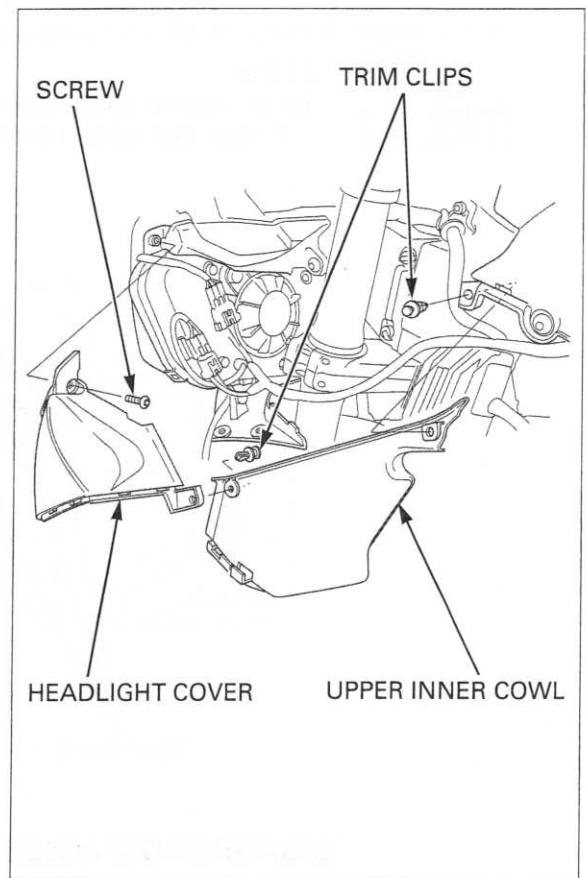

MIDDLE COWL

REMOVAL/INSTALLATION

Be careful not to damage the tabs. Remove the screws, trim clips and middle cowl.
Disconnect the turn signal light 3P connector.

Route the wires properly (page 1-21). Installation is in the reverse order of removal.

TORQUE:

Lower cowl-to-middle cowl screw:
1.5 N·m (0.2 kgf·m, 1.1 lbf·ft)

Be careful not to pinch the wires.

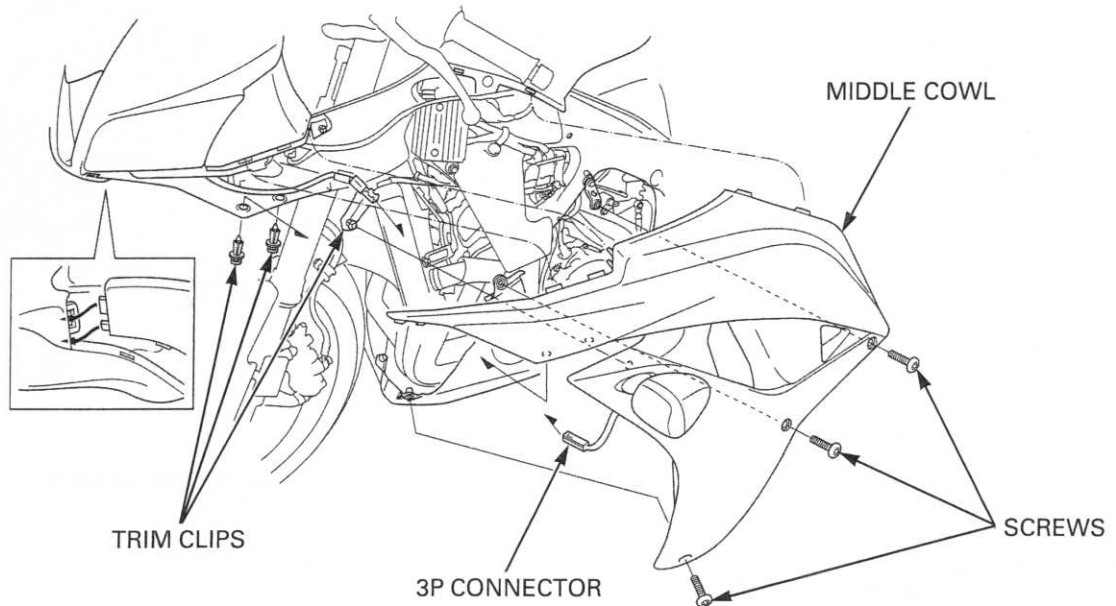

DISASSEMBLY/ASSEMBLY

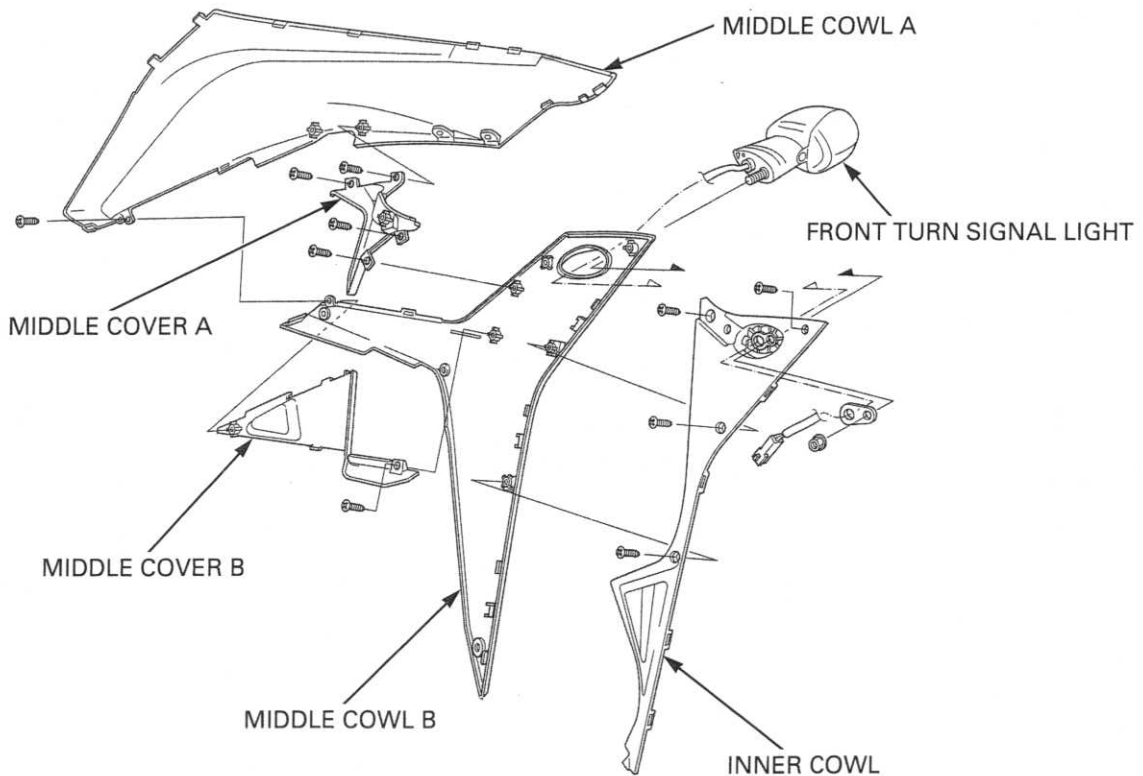

FUEL TANK COVER/SIDE COVER

REMOVAL/INSTALLATION

Remove the following:

- Seat (page 3-4)
- Middle cowls (page 3-8)
- Upper inner cowls (page 3-7)

Remove the screws, grommets, trim clips, collars and fuel tank cover/side cover assembly.

Be careful not to pinch the wires.

Installation is in the reverse order of removal.

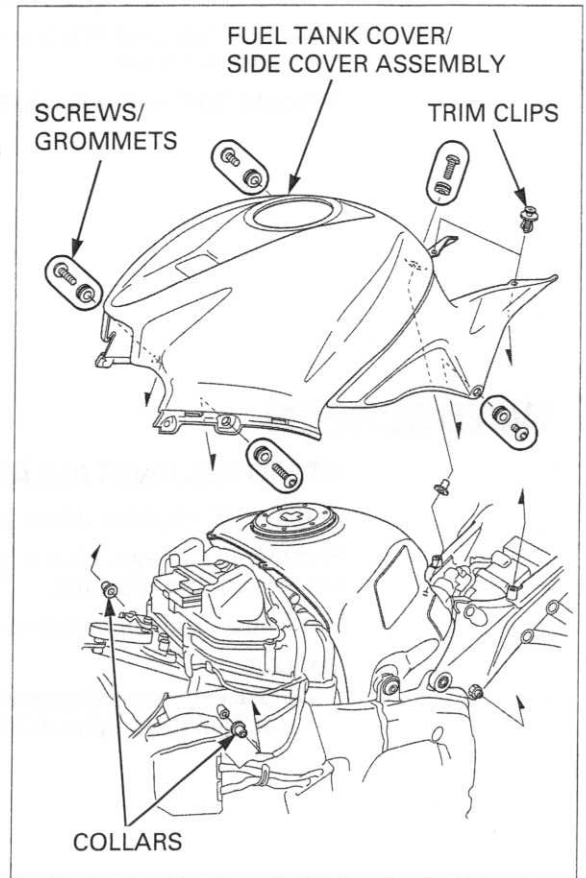

DISASSEMBLY/ASSEMBLY

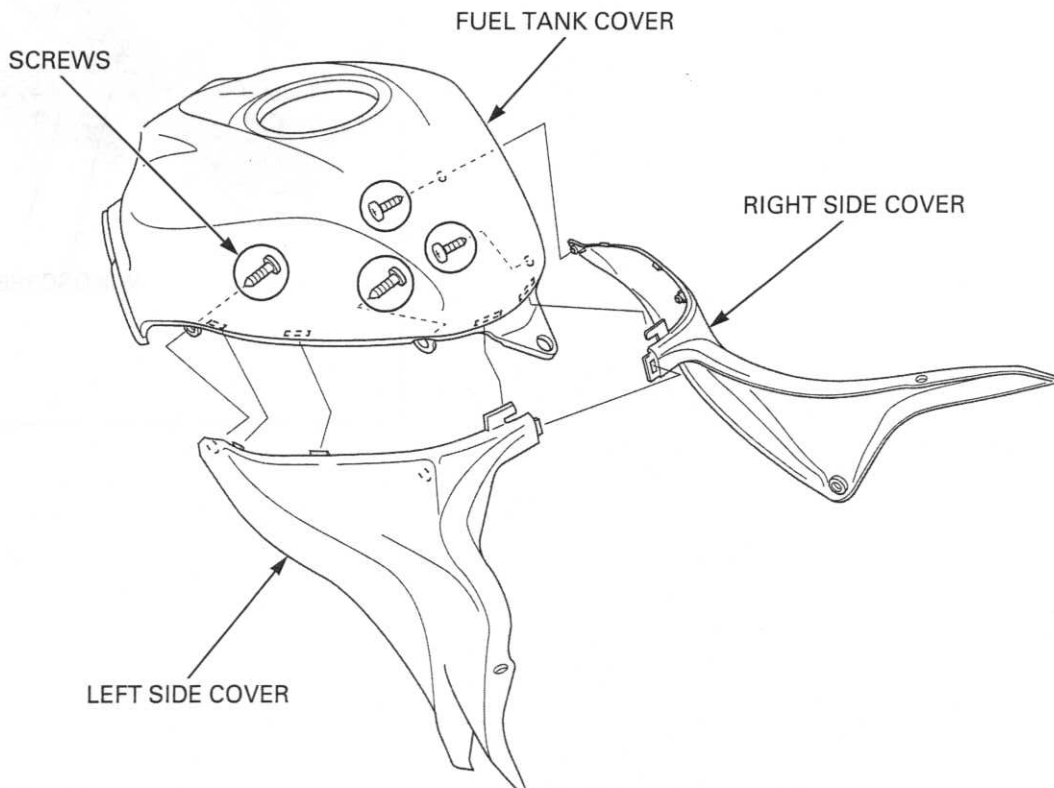

REARVIEW MIRROR

REMOVAL/INSTALLATION

Remove the bolts and rearview mirror.

Install the rearview mirror and tighten the bolts to the specified torque.

TORQUE: 7.0 N·m (0.7 kgf·m, 5.2 lbf·ft)

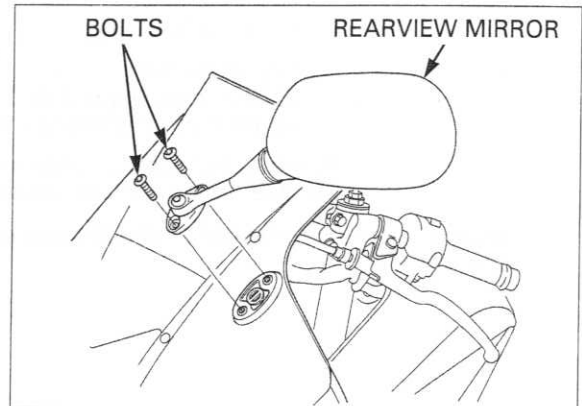

WINDSCREEN

REMOVAL/INSTALLATION

Remove the rearview mirror (page 3-10).

Remove the screws, plastic washers, rubber washers, windscreen and nuts.

Installation is in the reverse order of removal.

TORQUE:

Windscreen mounting screw:
0.45 N·m (0.05 kgf·m, 0.3 lbf·ft)

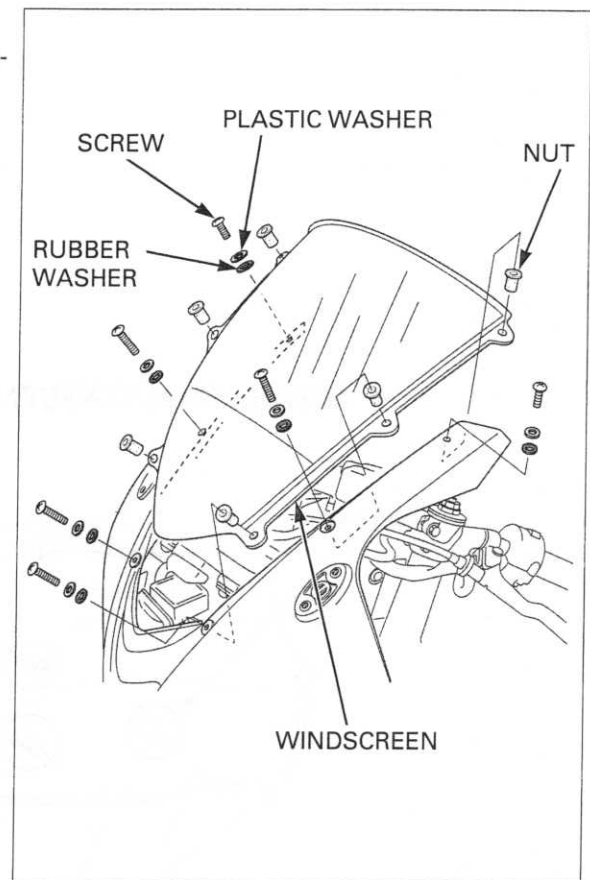

UPPER COWL/FRONT SPOILER

REMOVAL/INSTALLATION

Remove the following:

- Middle cowls (page 3-8)
- Headlight covers (page 3-7)
- Upper inner cowls (page 3-7)
- Windscreen (page 3-10)

Disconnect the position light 2P (Black) connector.

Remove the main wire harness 20P (Gray) connector from the front spoiler.

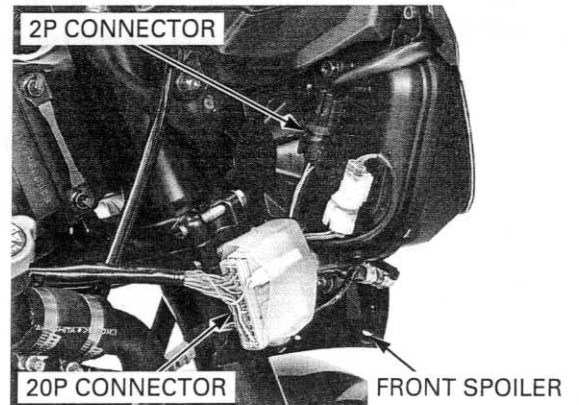

Remove the screws and upper cowl/front spoiler assembly.

Installation is in the reverse order of removal.

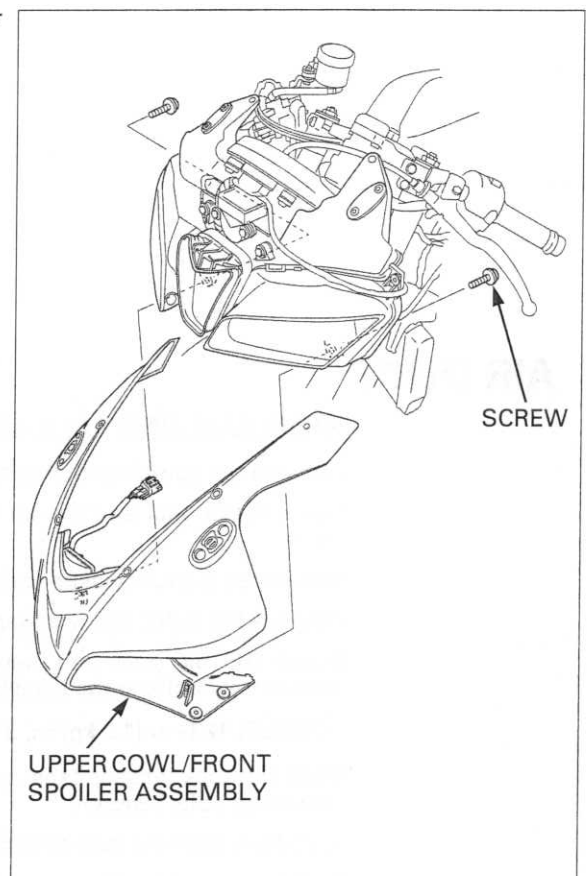

FRAME/BODY PANELS/EXHAUST SYSTEM

DISASSEMBLY/ASSEMBLY

Remove the screws and position light from the upper cowl.

Be careful not to damage the tabs.

Remove the front spoiler from the upper cowl.

Assembly is in the reverse order of disassembly.

TORQUE:

Position light mounting screw:

1.8 N·m (0.2 kgf·m, 1.3 lbf·ft)

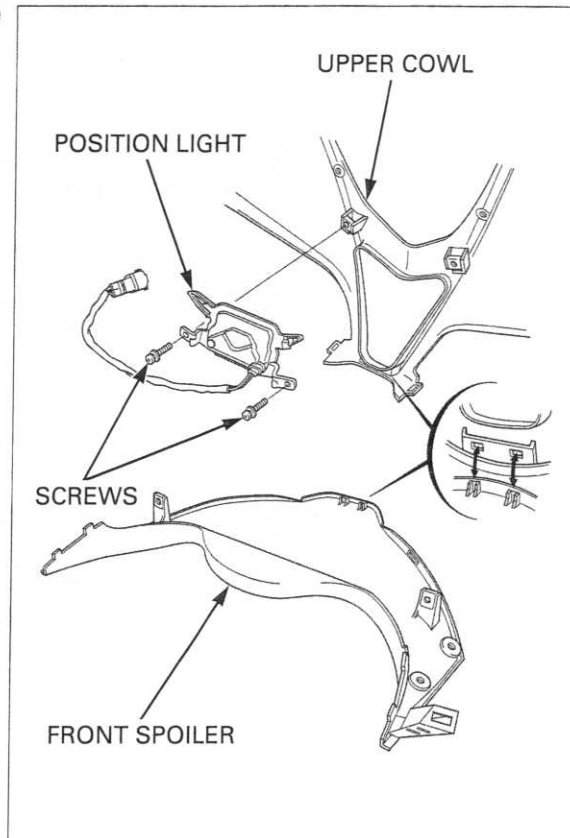

AIR DUCT

REMOVAL/INSTALLATION

Remove the combination meter (page 20-8).

Remove the duct attachment and grill from the air duct.

Straighten the lock washer tabs.

Remove the bolts, lock washers and air duct.

Install the air duct and new lock washers then tighten new bolts to the specified torque.

TORQUE: 12 N·m (1.2 kgf·m, 9 lbf·ft)

Bend the lock washer tabs up against the air duct mounting bolts securely.

Install the grill and duct attachment securely.

Install the combination meter (page 20-10).

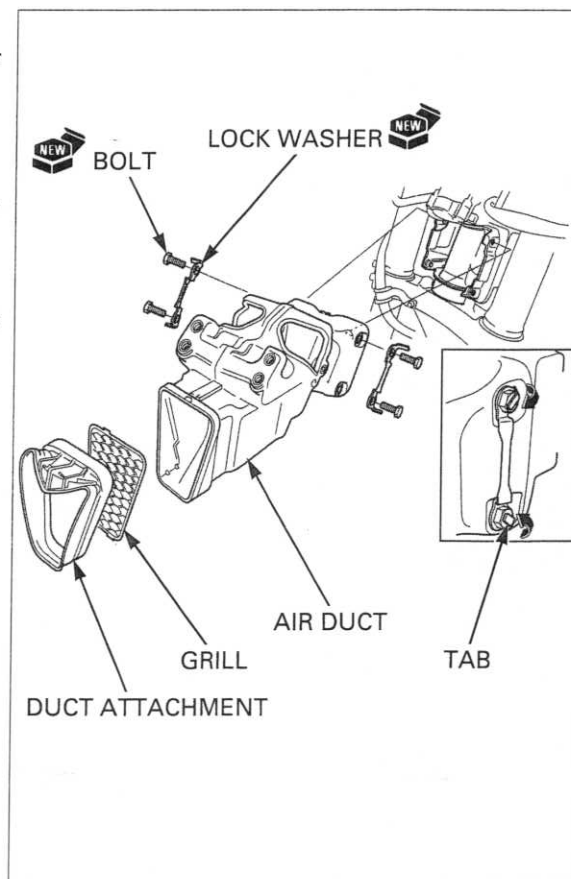

FRONT FENDER

REMOVAL/INSTALLATION

Remove the front brake hose 3-way joint bolt and hose clamp nut.

Remove the screws, grommets, collars, reflectors and front fender from the fork legs.

NOTE:

- Pull the front fender up and then pull it forward between the fork legs.
- Be careful not to damage the fork legs.

Installation is in the reverse order of removal.

TORQUE:

Front fender mounting screw:

12 N·m (1.2 kgf·m, 9 lbf·ft)

Front brake hose clamp nut:

10 N·m (1.0 kgf·m, 7 lbf·ft)

Front brake hose 3-way joint bolt:

10 N·m (1.0 kgf·m, 7 lbf·ft)

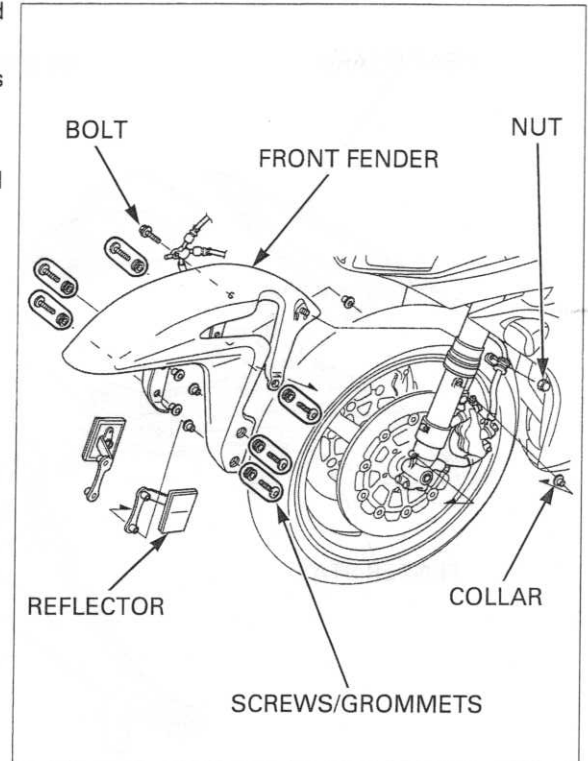

REAR FENDER A

REMOVAL/INSTALLATION

Remove the rear cowl (page 3-5).

Disconnect the brake/tail and turn signal light connectors.

Remove the bolts, reflectors and rear fender A assembly rearward.

Installation is in the reverse order of removal.

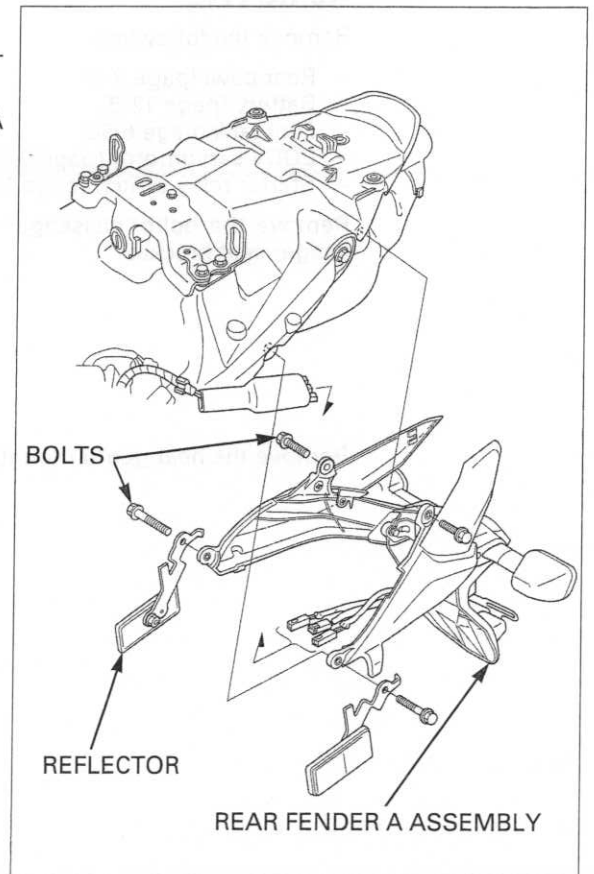

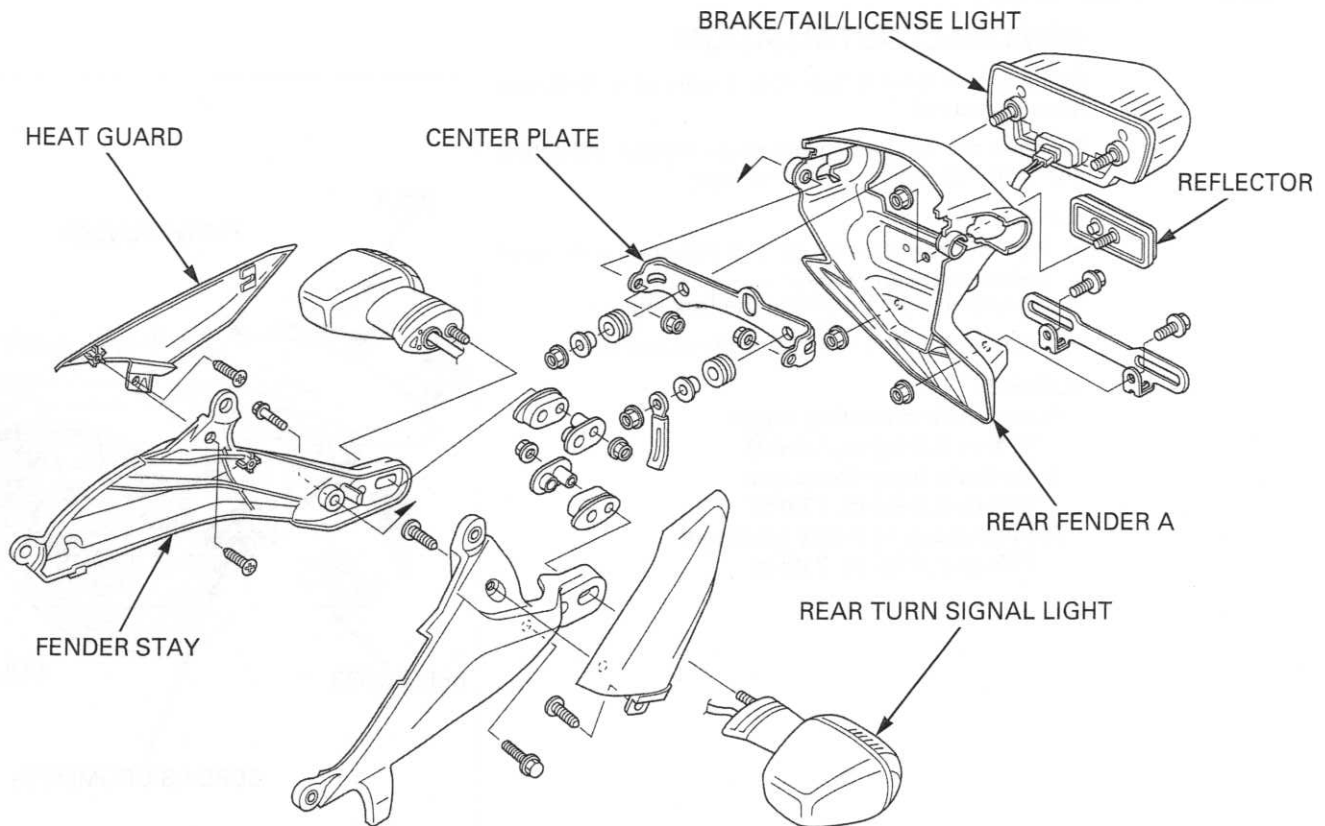

REAR FENDER B

REMOVAL

Remove the following:

- Rear cowl (page 3-5)
- Battery (page 17-6)
- Fuel tank (page 6-50)
- EGCV servomotor (page 6-80)
- Starter relay switch (page 19-14)

Remove the bolts, passenger seat hooks and passenger seat bracket.

Remove the heat guard mounting screw.

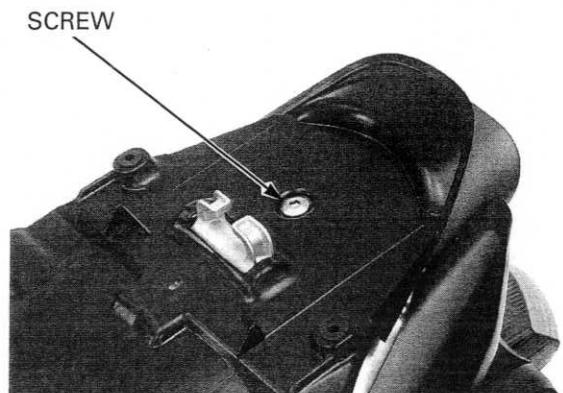
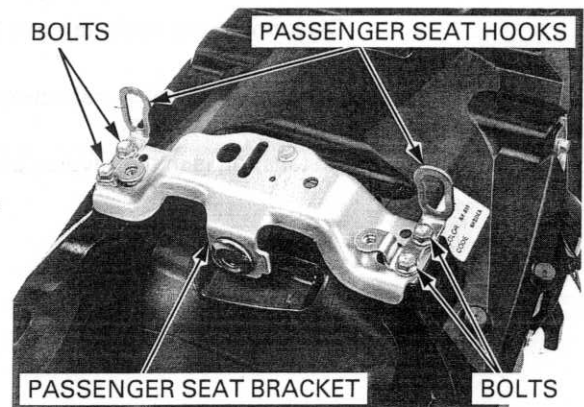

Release the rear brake light switch 2P (Black) connector from the rear fender B.

Release the wire harnesses from the rear fender B.

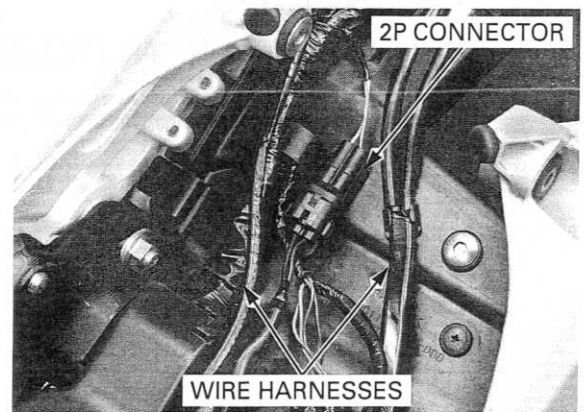

Remove the trim clips, screw and rear fender B.

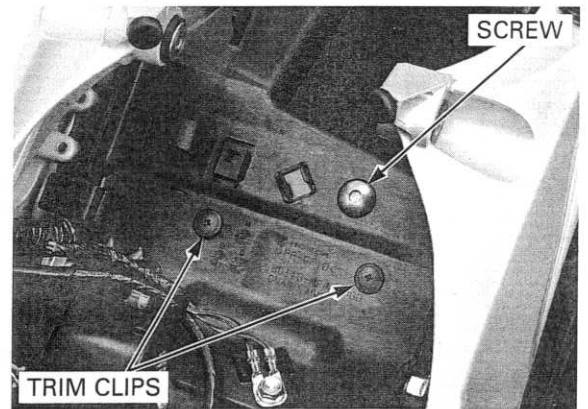

INSTALLATION

Route the wires properly (page 1-21).

Installation is in the reverse order of removal.

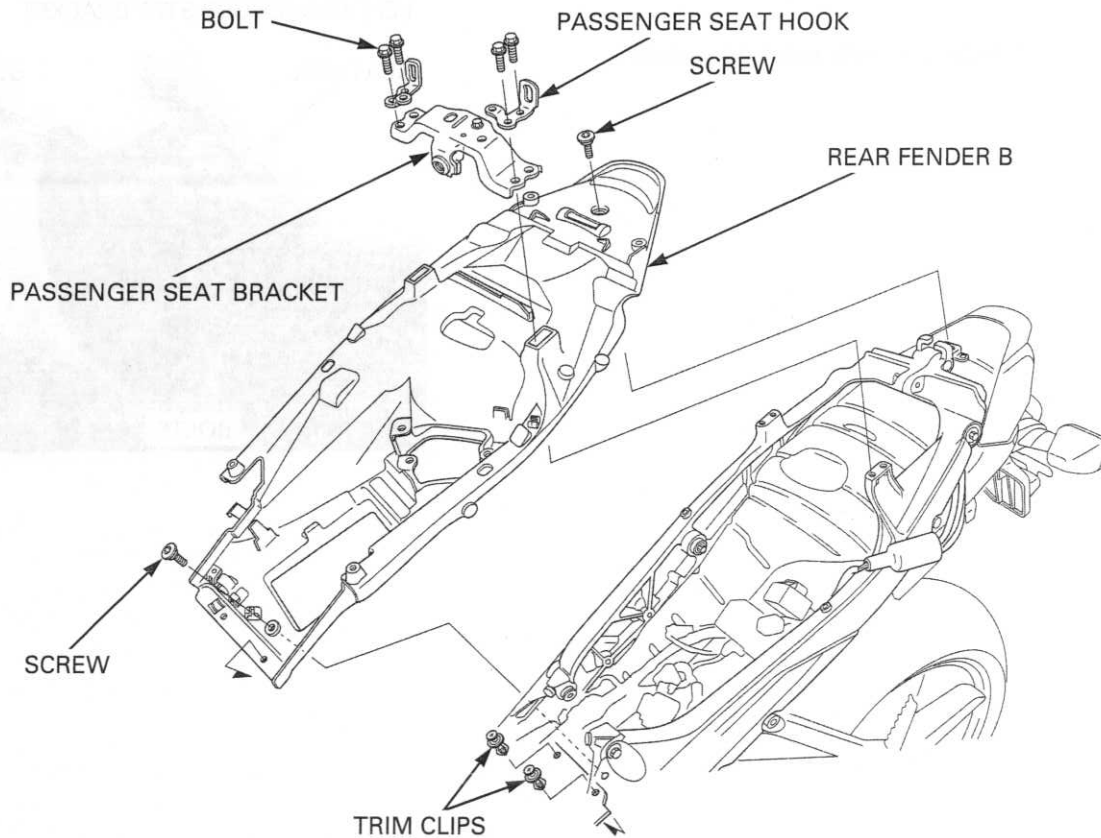

REAR FENDER C

REMOVAL/INSTALLATION

Remove the special screws, rear fender C and brake hose guide from the swingarm.

Install the brake hose guide by aligning its tab to the swingarm hole.

Install the rear fender C and tighten the special screws securely.

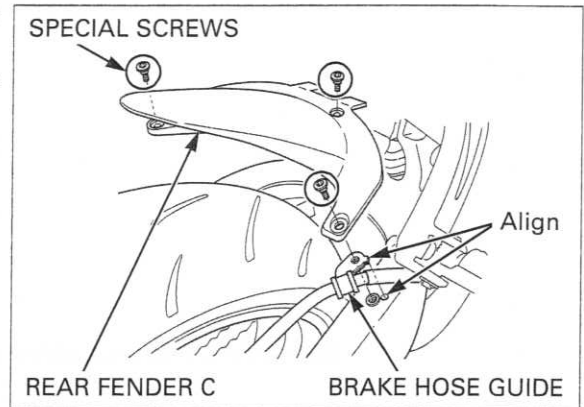

SEAT RAIL

REMOVAL

Remove the following:

- Fuel tank (page 6-50)
- Muffler (page 3-19)
- Rear fender A (page 3-13)
- Rear fender B (page 3-14)

Remove the bolts and left passenger step bracket.

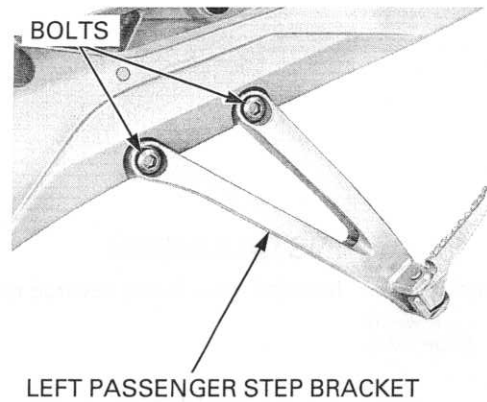

Remove the bolts, nuts and seat rail.

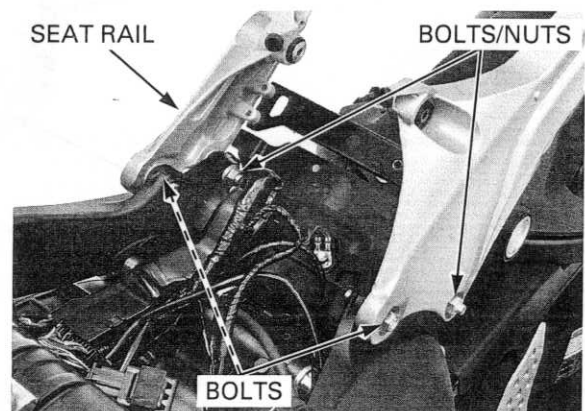

DISASSEMBLY

Remove the bolts.

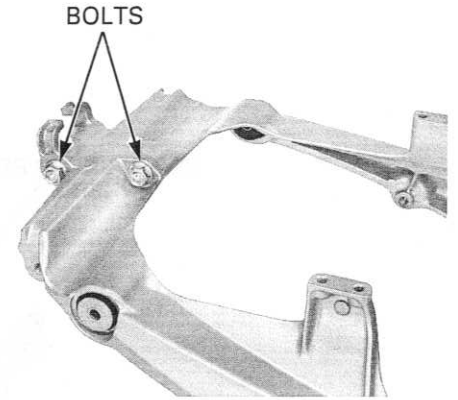

Remove the bolts and rear fender bracket.
Separate the seat rail.

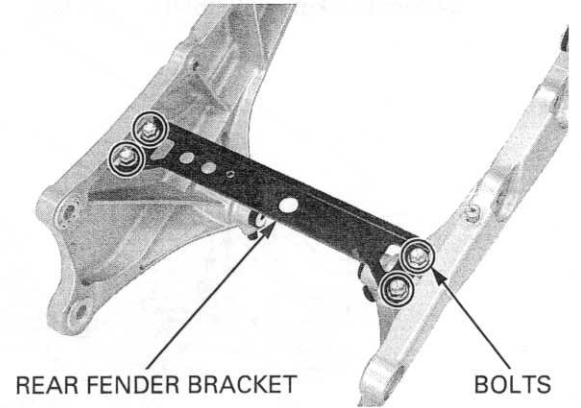

Remove the dowel pin from the seat rail.

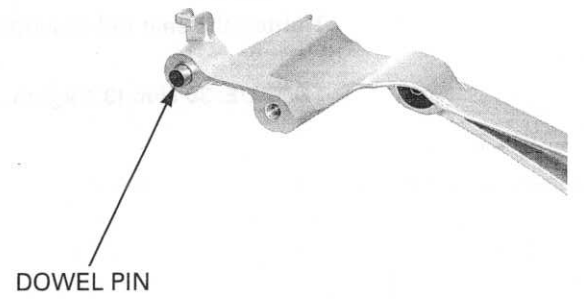

FRAME/BODY PANELS/EXHAUST SYSTEM

ASSEMBLY

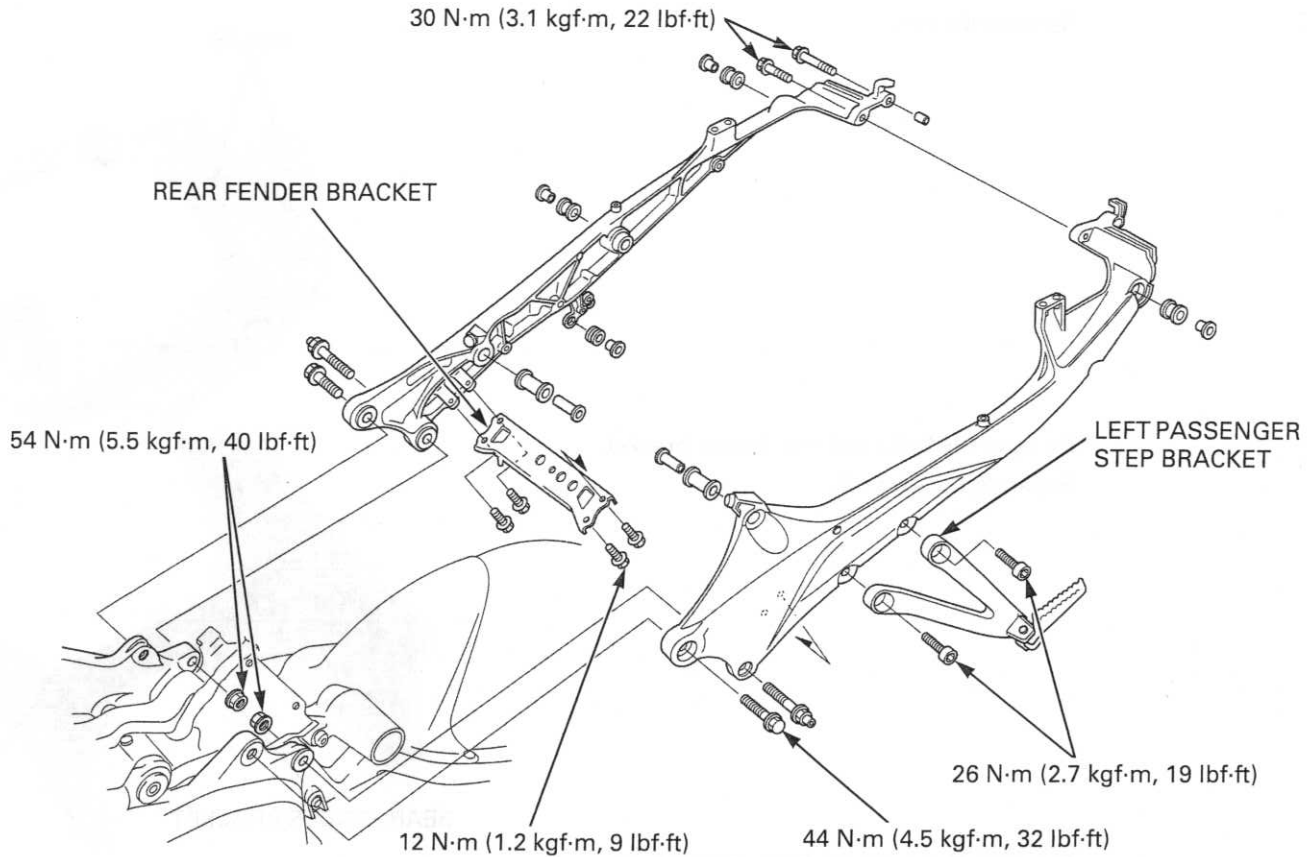

Install the dowel pin onto the seat rail and assemble the seat rail.

Tighten the seat rail assembly bolts to the specified torque.

TORQUE: 30 N·m (3.1 kgf·m, 22 lbf·ft)

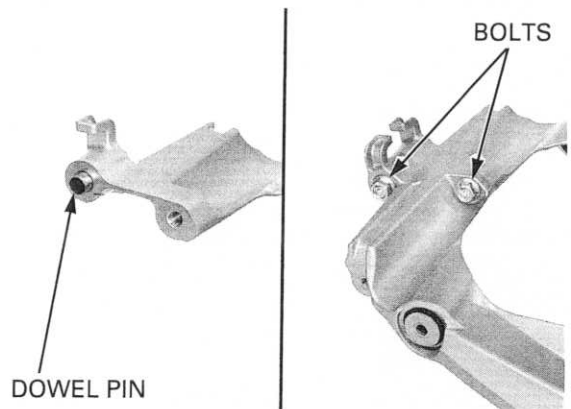

Install the rear fender bracket and bolts temporarily.

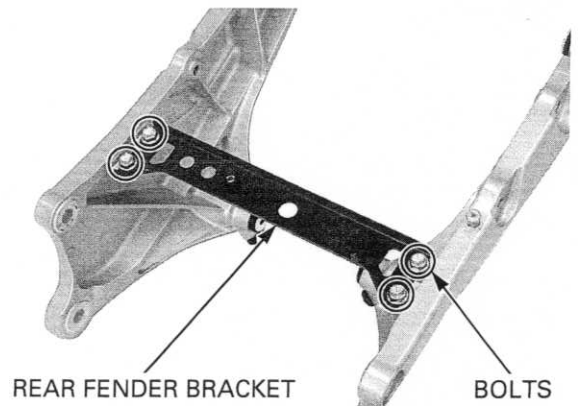

INSTALLATION

Install the seat rail, bolts and nuts.

Tighten the bolts and nuts to the specified torque.

TORQUE:

Seat rail mounting bolt:

44 N·m (4.5 kgf·m, 32 lbf·ft)

Seat rail mounting nut:

54 N·m (5.5 kgf·m, 40 lbf·ft)

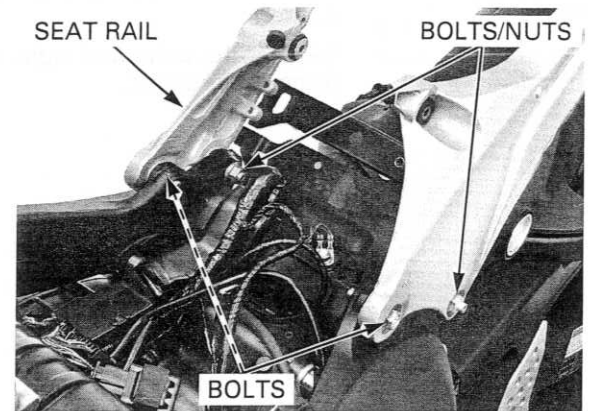

Tighten the rear fender bracket mounting bolts to the specified torque.

TORQUE: 12 N·m (1.2 kgf·m, 9 lbf·ft)

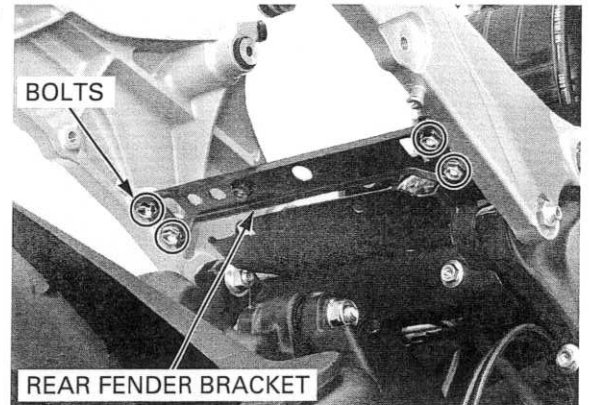

Install the left passenger step bracket and tighten the bolts to the specified torque.

TORQUE: 26 N·m (2.7 kgf·m, 19 lbf·ft)

Install the following:

- Rear fender B (page 3-15)
- Rear fender A (page 3-13)
- Muffler (page 3-22)
- Fuel tank (page 6-50)

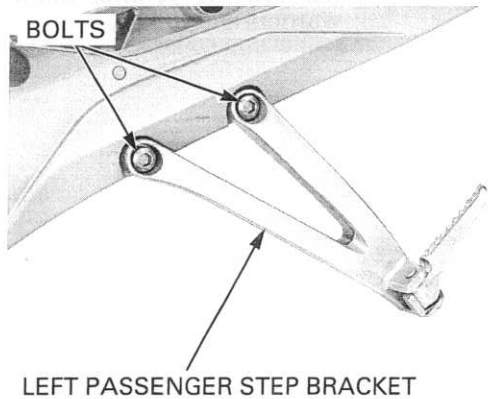

MUFFLER

REMOVAL

Remove the following:

- Rear fender A (page 3-13)
- Right passenger step bracket (page 16-19)

Unhook the rear brake light switch spring from the brake pedal.

Remove the rear brake light switch.

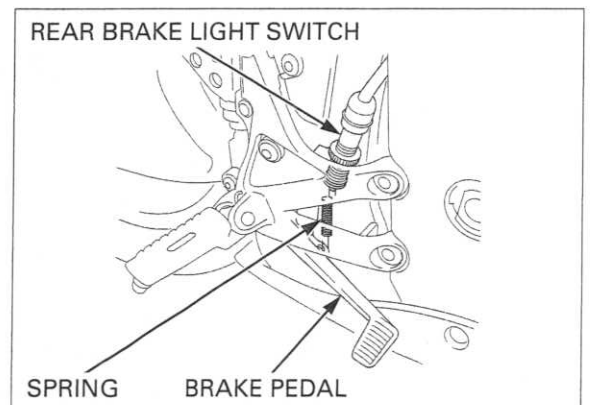

FRAME/BODY PANELS/EXHAUST SYSTEM

Keep the rear reserve tank upright to prevent air from entering the hydraulic system.

Remove the bolt and rear brake reserve tank.

Remove the heat guard mounting screw and washer.

Remove the bolts and right main step/heat guard assembly as shown.

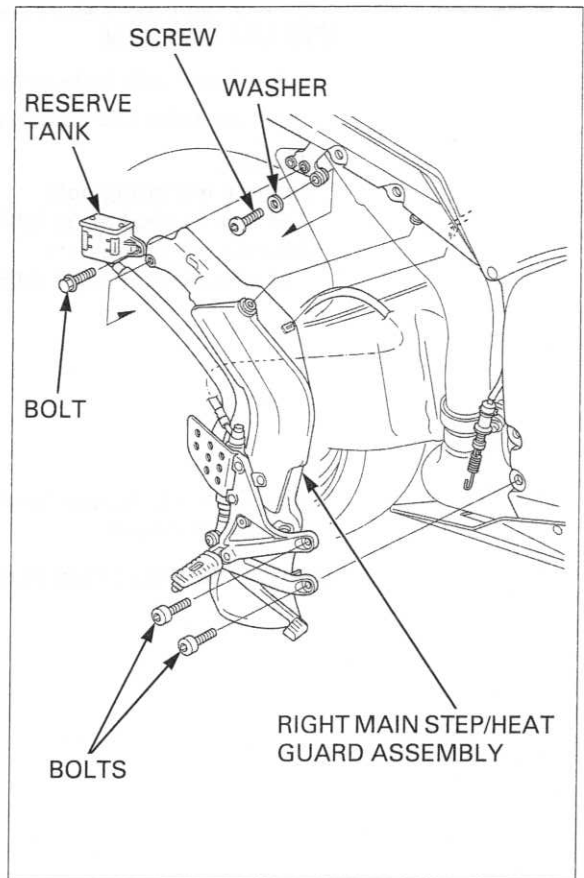

Remove the screws, muffler rear cover, rubber washers and collars.

SCREWS/RUBBER WASHERS/COLLARS

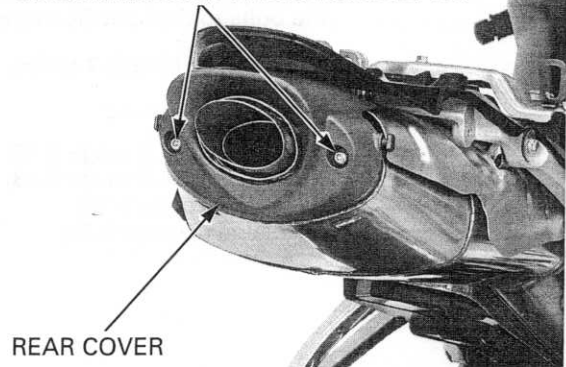

Remove the screws and muffler rear cap.

SCREWS

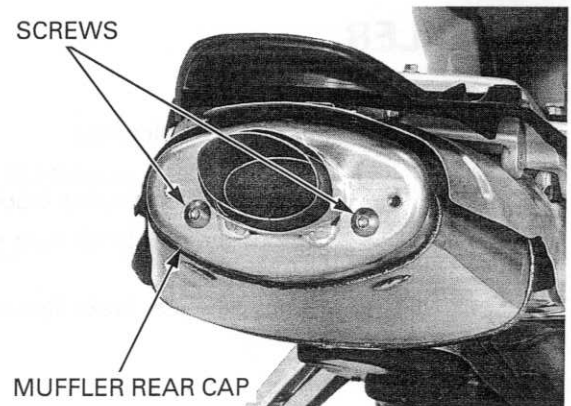

Loosen the muffler band bolt.

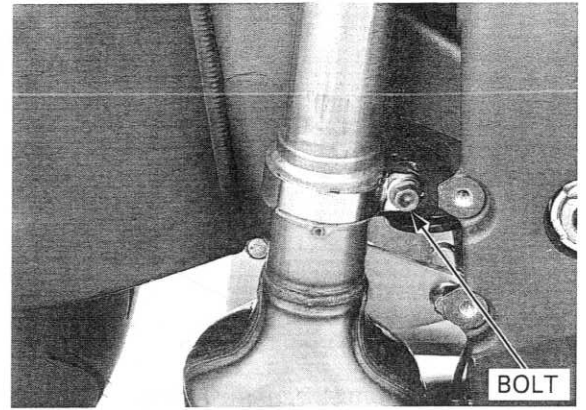

Remove the bolts and muffler.

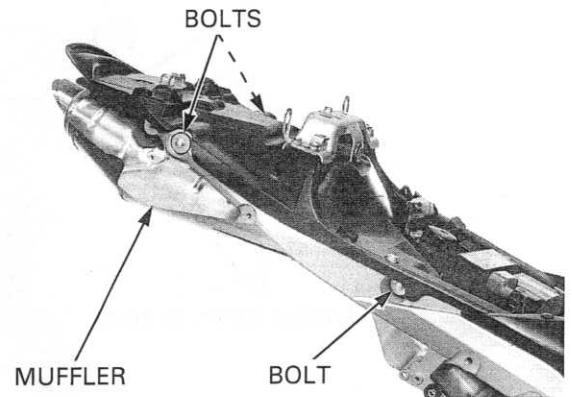

Remove the screw, bolt and heat guard.

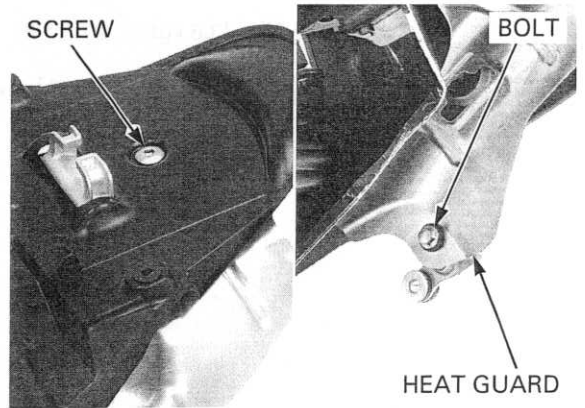

FRAME/BODY PANELS/EXHAUST SYSTEM INSTALLATION

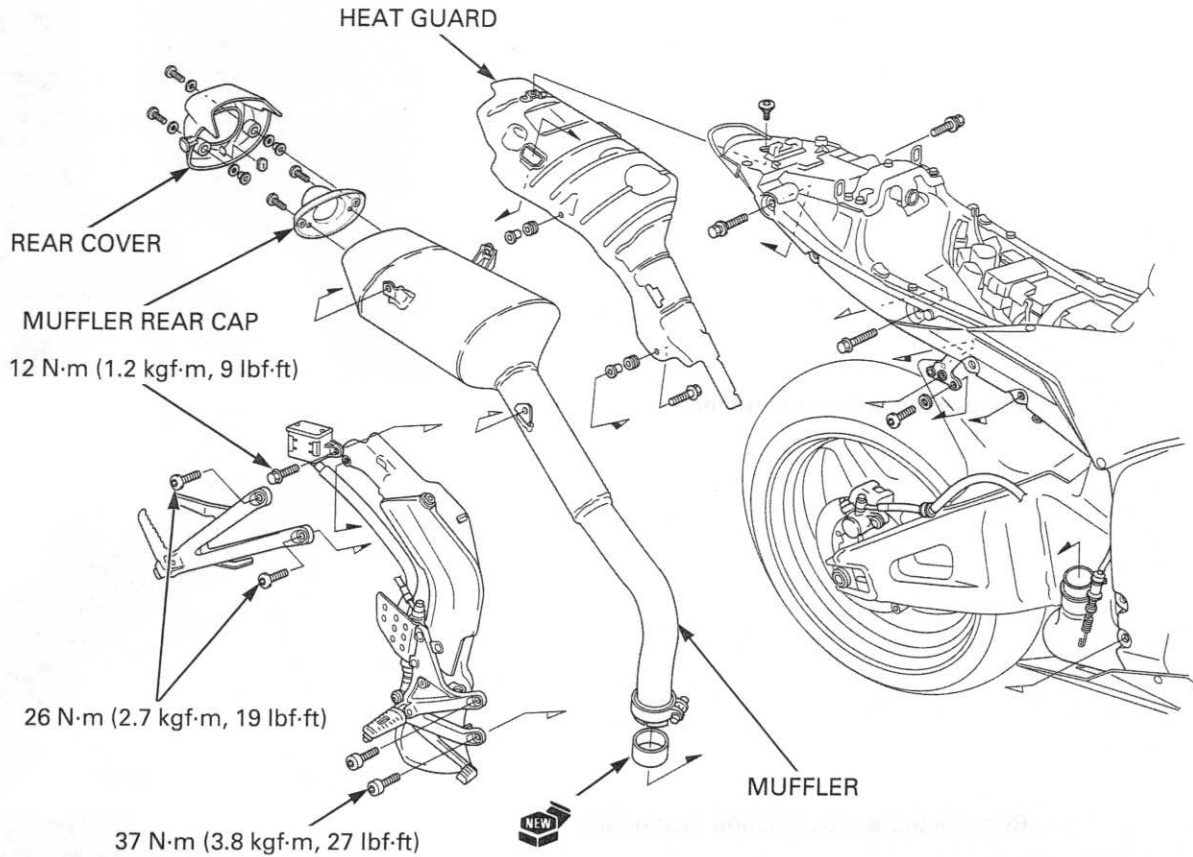

Install the heat guard and tighten the screw and bolt securely.

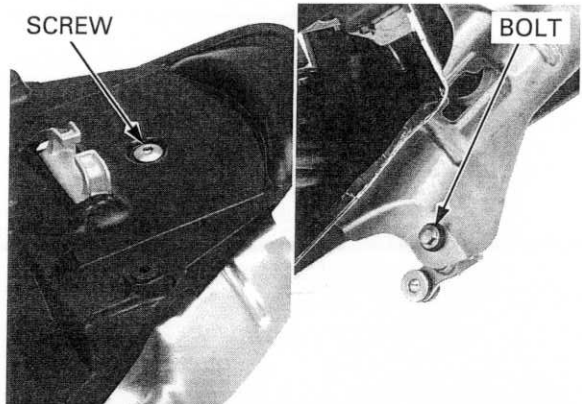

Install a new gasket onto the exhaust pipe and install the muffler onto the exhaust pipe.

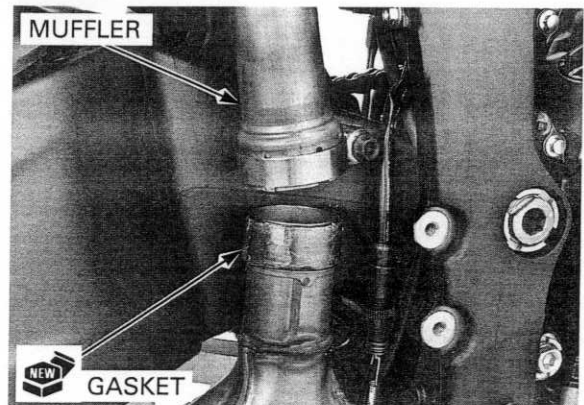

Install the muffler and bolts.
Tighten the bolts securely.

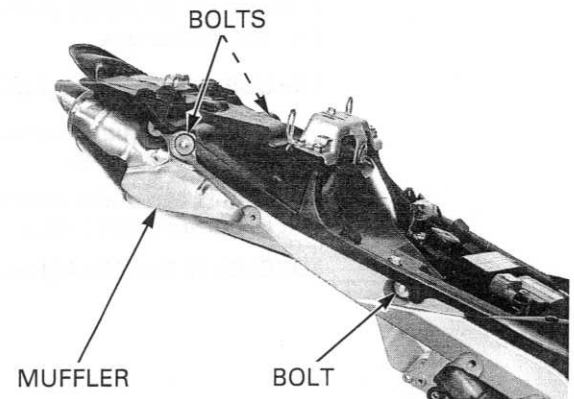

Tighten the muffler band bolt to the specified torque.

TORQUE: 17 N·m (1.7 kgf·m, 13 lbf·ft)

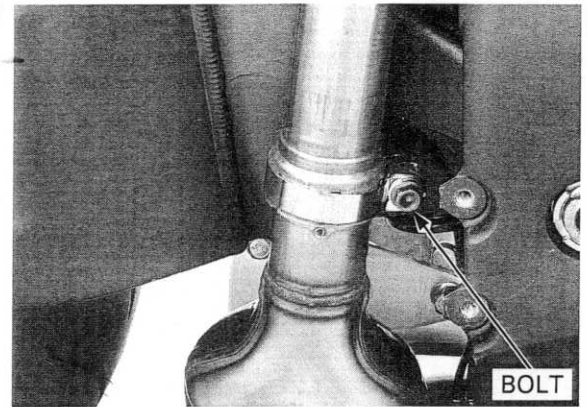

Install the muffler rear cap and tighten the screws securely.

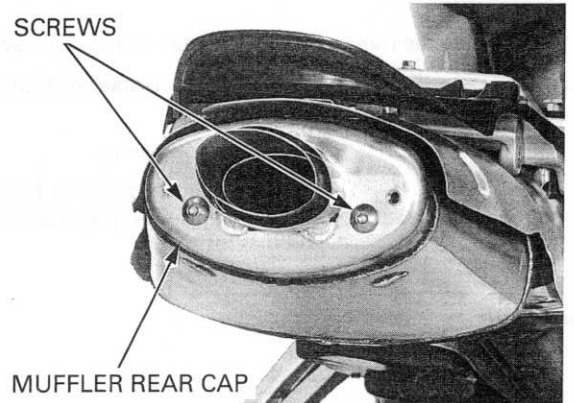

Install the rubber washers and collars onto the muffler rear cover.

Install the muffler rear cover and tighten the screws securely.

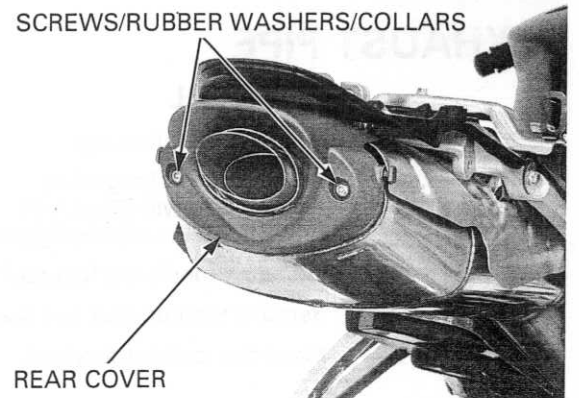

FRAME/BODY PANELS/EXHAUST SYSTEM

Install the right main step/heat guard assembly as shown and tighten the main step mounting bolts to the specified torque.

TORQUE: 37 N·m (3.8 kgf·m, 27 lbf·ft)

Install the heat guard mounting screw and washer, then tighten it securely.

Install the rear brake reserve tank and tighten the bolt to the specified torque.

TORQUE: 12 N·m (1.2 kgf·m, 9 lbf·ft)

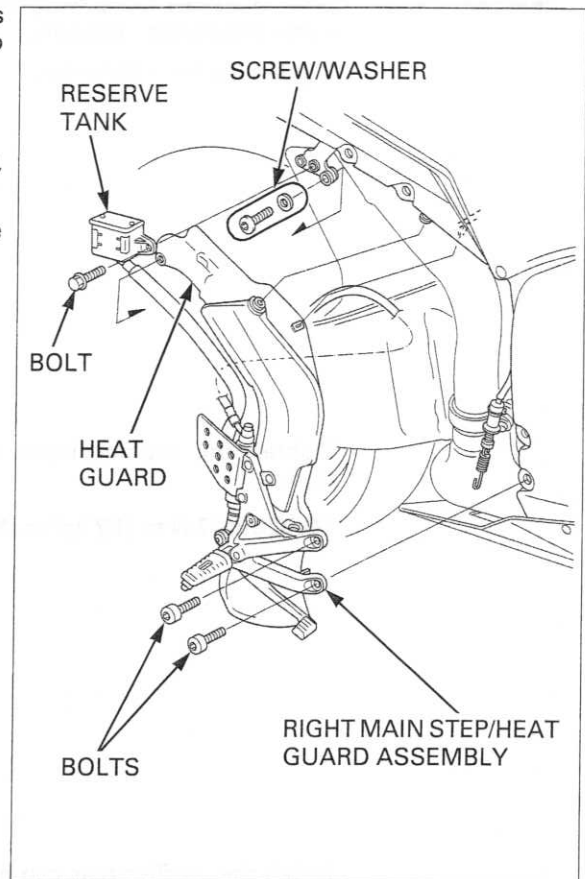

Route the wires properly (page 1-21).

Install the rear brake light switch.

Hook the rear brake light switch spring to the brake pedal.

Install the following:

- Right passenger step bracket (page 16-24)
- Rear fender A (page 3-13)

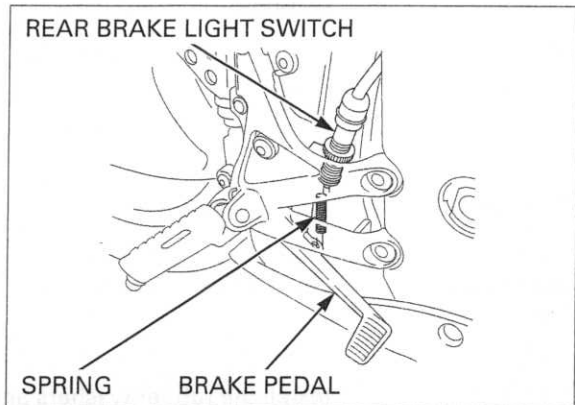

EXHAUST PIPE

REMOVAL

Remove the following:

- Lower cowl (page 3-6)
- Middle cowls (page 3-8)
- Right main step/heat guard assembly (page 3-19)

Lift and support the fuel tank (page 4-5).

Remove the nut, bolt and washer.

Move the radiator forward.

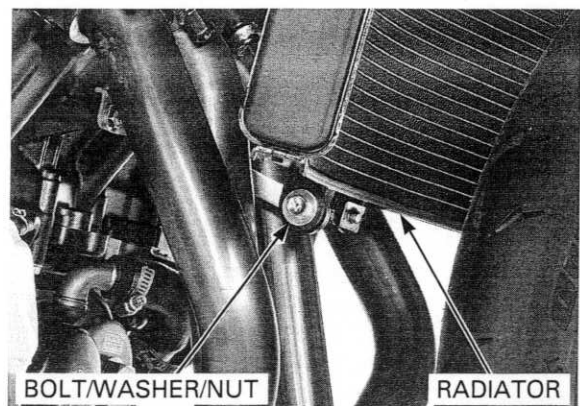

Loosen the muffler band bolt.

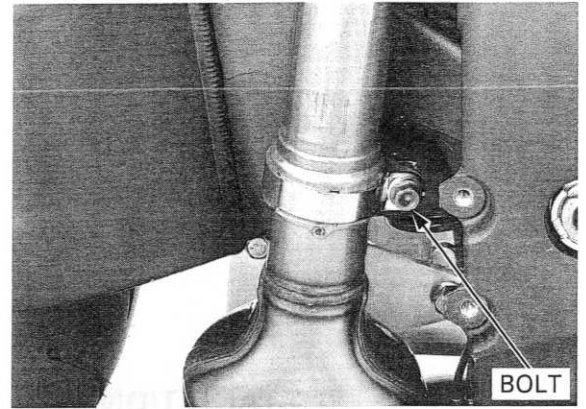

Remove the exhaust pipe joint nuts.

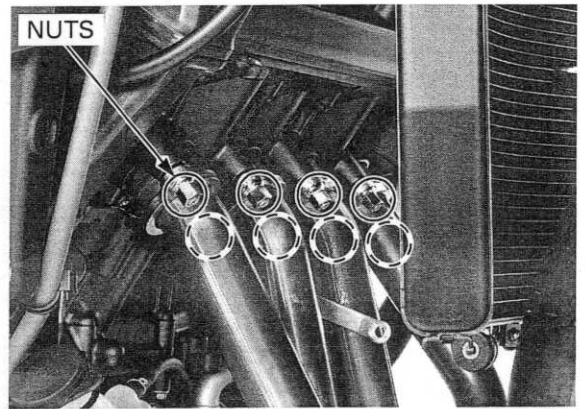

Remove the nuts, bolts and EGCV cover.
Loosen the lock nuts fully and disconnect the EGCV control cables from the pulley.

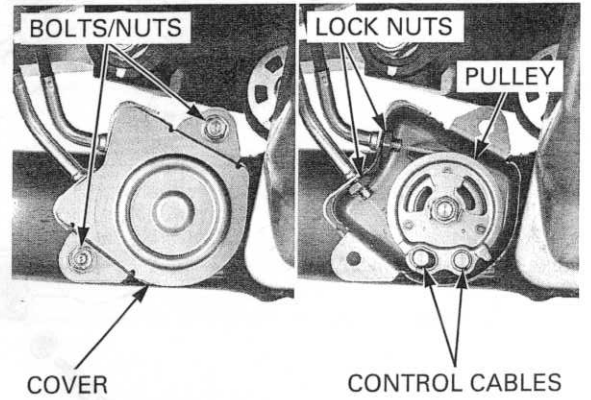

Remove the bolt, washer, collar and exhaust pipe.

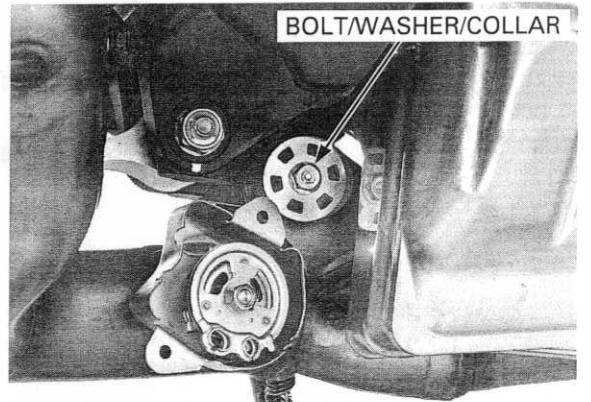

FRAME/BODY PANELS/EXHAUST SYSTEM

Remove the exhaust pipe gaskets.

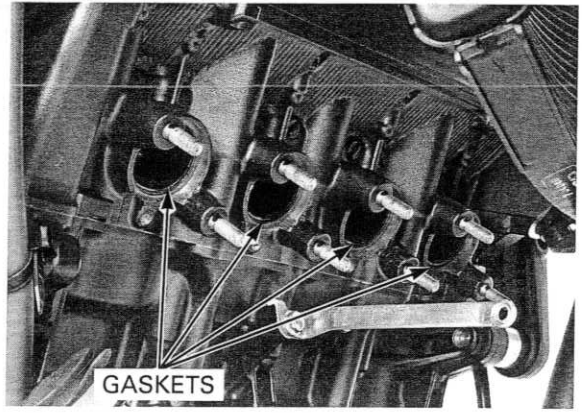

INSTALLATION

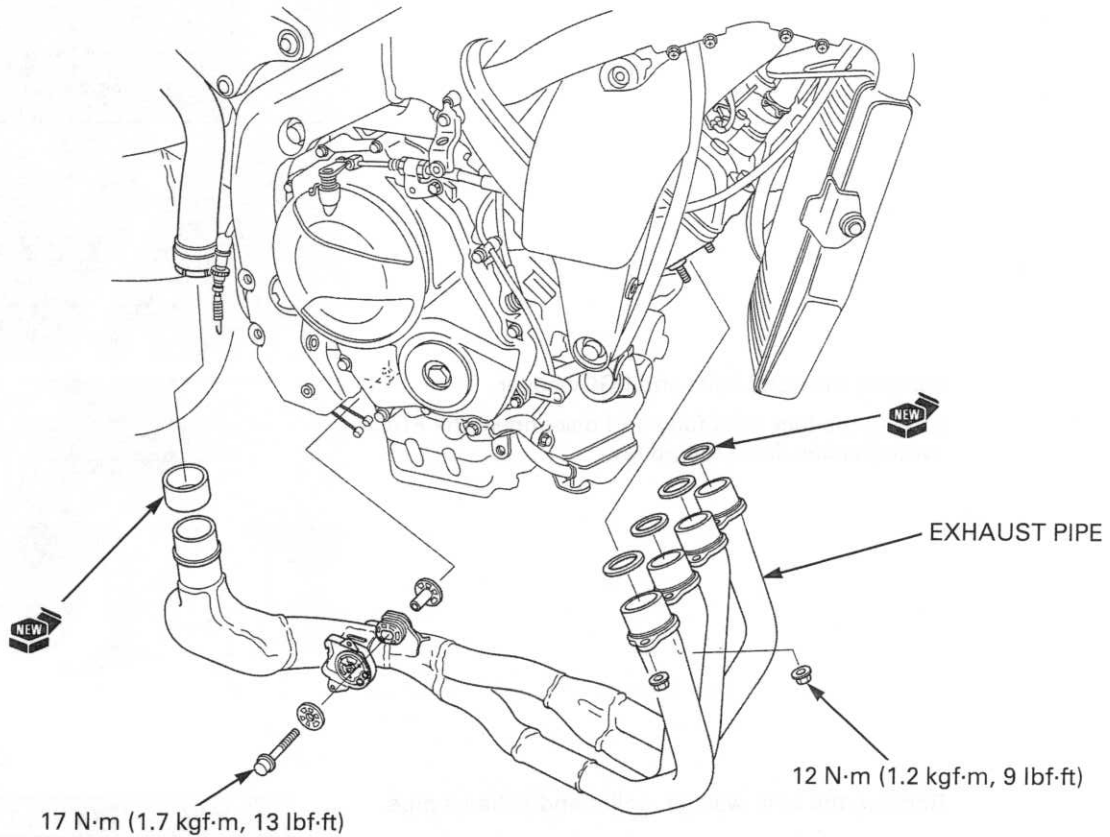

Check the exhaust pipe stud protrusion from the exhaust port.

SPECIFIED LENGTH: 45.0 – 46.0 mm (1.77 – 1.81 in)

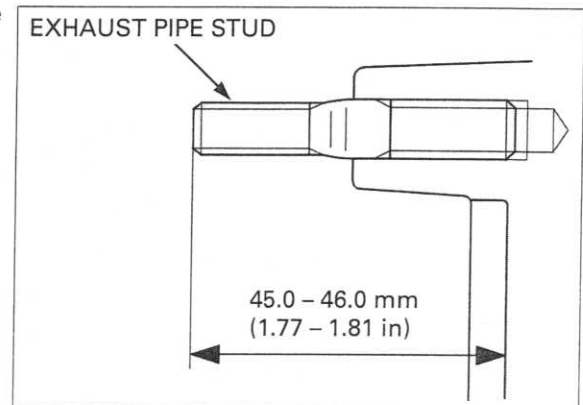

Always replace the exhaust pipe gaskets with new ones. Install new exhaust pipe gaskets onto the exhaust ports of the cylinder head.

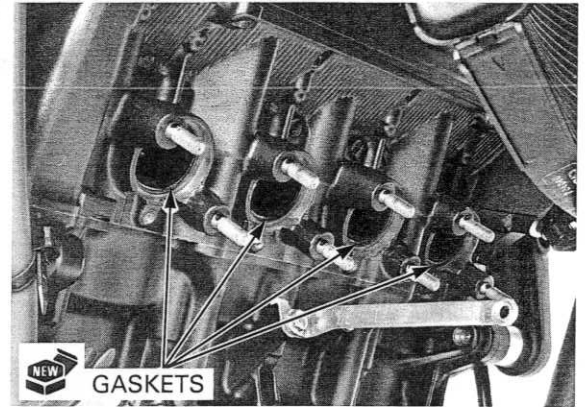

Install a new gasket onto the exhaust pipe and install the exhaust pipe into the muffler and cylinder head.

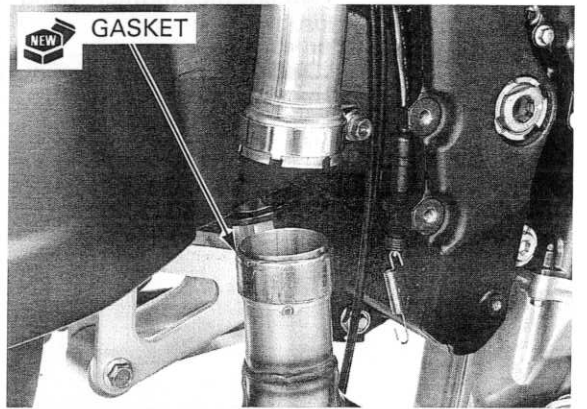

Loosely install the exhaust pipe, collar and mounting bolt/washer.

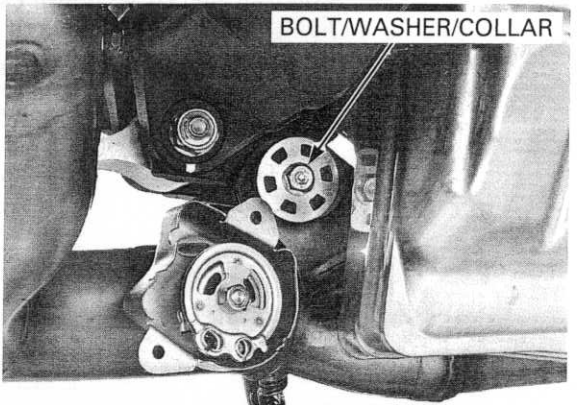

Tighten the exhaust pipe joint nuts to the specified torque.

TORQUE: 12 N·m (1.2 kgf·m, 9 lbf·ft)

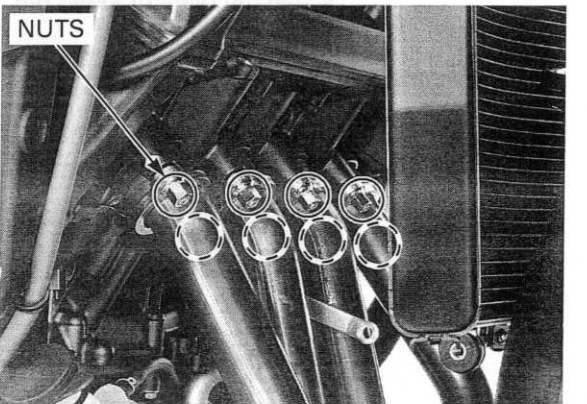

FRAME/BODY PANELS/EXHAUST SYSTEM

Tighten the exhaust pipe mounting bolt to the specified torque.

TORQUE: 17 N·m (1.7 kgf·m, 13 lbf·ft)

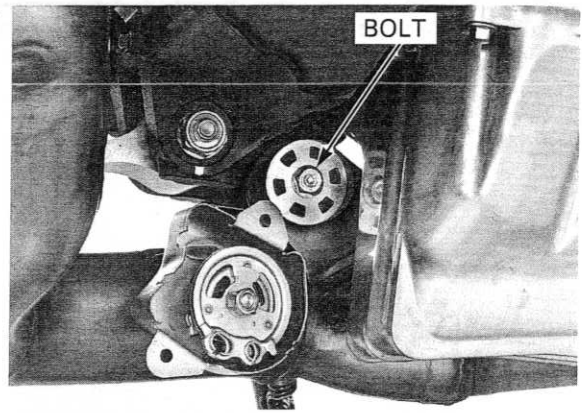

Tighten the muffler band bolt to the specified torque.

TORQUE: 17 N·m (1.7 kgf·m, 13 lbf·ft)

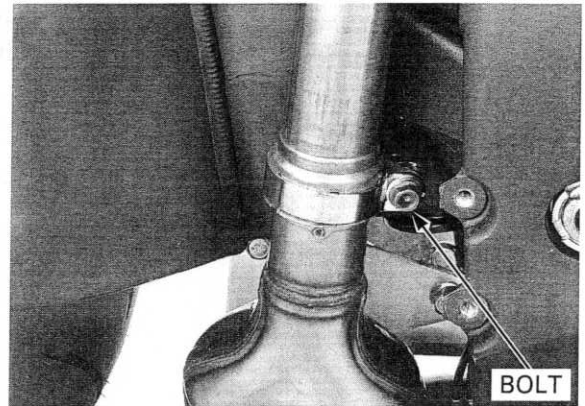

Connect the EGCV control cables to the pulley and tighten the lock nuts securely.

Adjust the EGCV control cable (page 4-23).

Install the EGCV cover, bolts and tighten the nuts securely.

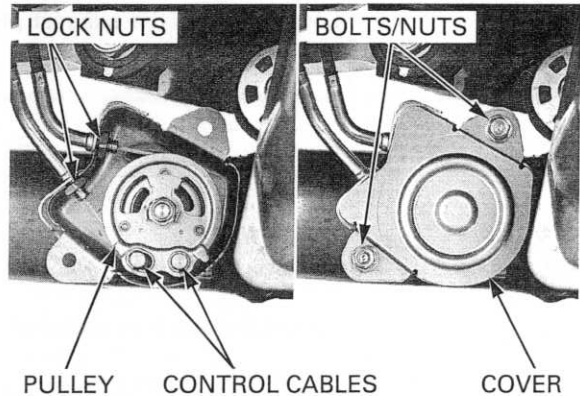

Install the radiator lower mounting bolt, washer and nut.

Tighten the nut securely.

Remove the suitable support and close the fuel tank (page 4-6).

Install the following:

- Middle cowls (page 3-8)
- Lower cowl (page 3-6)
- Right main step/heat guard assembly (page 3-24)

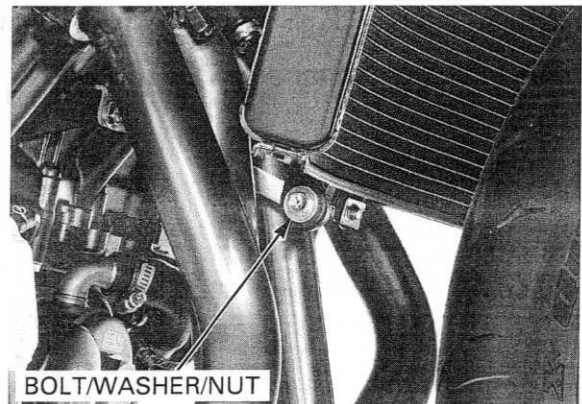

SERVICE INFORMATION	4-2	EGCV CABLE	4-22
MAINTENANCE SCHEDULE	4-4	DRIVE CHAIN	4-23
FUEL LINE	4-5	BRAKE FLUID	4-28
THROTTLE OPERATION	4-8	BRAKE PADS WEAR	4-29
AIR CLEANER	4-8	BRAKE SYSTEM	4-30
SPARK PLUG	4-9	BRAKE LIGHT SWITCH	4-31
VALVE CLEARANCE	4-13	HEADLIGHT AIM	4-31
ENGINE OIL/OIL FILTER	4-17	CLUTCH SYSTEM	4-31
RADIATOR COOLANT	4-19	SIDESTAND	4-32
COOLING SYSTEM	4-20	SUSPENSION	4-32
SECONDARY AIR SUPPLY SYSTEM	4-20	NUTS, BOLTS, FASTENERS	4-35
EVAPORATIVE EMISSION CONTROL SYSTEM (CALIFORNIA TYPE)	4-21	WHEELS/TIRES	4-35
		STEERING HEAD BEARINGS	4-36

MAINTENANCE

SERVICE INFORMATION

GENERAL

- Place the motorcycle on level ground before starting any work.
- The exhaust contains poisonous carbon monoxide gas that may cause loss of consciousness and may lead to death. Run the engine in an open area or with an exhaust evacuation system in and enclosed area.

SPECIFICATIONS

ITEM		SPECIFICATIONS	
Throttle grip freeplay		2 – 4 mm (1/16 – 3/16 in)	
Spark plug	NGK	IMR9C-9HES	
	DENSO	VUH27D	
Spark plug gap		0.80 – 0.90 mm (0.031 – 0.035 in)	
Valve clearance	IN	0.20 ± 0.03 mm (0.008 ± 0.001 in)	
	EX	0.28 ± 0.03 mm (0.011 ± 0.001 in)	
Engine oil capacity	After draining	2.7 liter (2.9 US qt, 2.4 Imp qt)	
	After oil filter change	2.8 liter (3.0 US qt, 2.5 Imp qt)	
Recommended engine oil		Pro Honda GN4 4-stroke oil (U.S.A. and Canada) or equivalent motor oil API service classification: SG or Higher JASO T 903 standard: MA Viscosity: SAE 10W-30	
Recommended antifreeze		Pro Honda HP Coolant or an equivalent high quality ethylene glycol antifreeze containing silicate free corrosion inhibitors	
Drive chain	Size/link	DID	DID 525HV KAI – 112YB
		RK	RK 525ROZ6 – 112LJFZ
Slack		30 – 40 mm (1.2 – 1.6 in)	
Recommended brake fluid		DOT 4	
Clutch lever freeplay		10 – 20 mm (3/8 – 13/16 in)	
Tire size	Front		120/70 ZR 17 M/C (58W)
	Rear		180/55 ZR 17 M/C (73W)
Tire brand	Bridgestone	Front	BT015F RADIAL E
		Rear	BT015R RADIAL E
	Dunlop	Front	Qualifier PTG
		Rear	Qualifier PTG
Cold tire pressure	Driver only	Front	250 kPa (2.50 kgf/cm ² , 36 psi)
		Rear	290 kPa (2.90 kgf/cm ² , 42 psi)
	Driver and passenger	Front	250 kPa (2.50 kgf/cm ² , 36 psi)
		Rear	290 kPa (2.90 kgf/cm ² , 42 psi)
Minimum tire tread depth	Front		1.5 mm (0.06 in)
	Rear		2.0 mm (0.08 in)

TORQUE VALUES

Spark plug	16 N·m (1.6 kgf·m, 12 lbf·ft)	
Timing hole cap	18 N·m (1.8 kgf·m, 13 lbf·ft)	Apply grease to the threads
Oil drain bolt	30 N·m (3.1 kgf·m, 22 lbf·ft)	
Oil filter cartridge	26 N·m (2.7 kgf·m, 19 lbf·ft)	Apply oil to the O-ring
Rear axle nut	113 N·m (11.5 kgf·m, 83 lbf·ft)	U-nut
Drive sprocket bolt	54 N·m (5.5 kgf·m, 40 lbf·ft)	
Driven sprocket nut	64 N·m (6.5 kgf·m, 47 lbf·ft)	U-nut
Rear master cylinder push rod lock nut	18 N·m (1.8 kgf·m, 13 lbf·ft)	
Fuel tank mounting bolt	30 N·m (3.1 kgf·m, 22 lbf·ft)	
Air cleaner element mounting screw	4.2 N·m (0.4 kgf·m, 3.1 lbf·ft)	
Sidestand pivot bolt	10 N·m (1.0 kgf·m, 7 lbf·ft)	
Sidestand pivot nut	29 N·m (3.0 kgf·m, 21 lbf·ft)	
ECM setting plate screw	0.7 N·m (0.07 kgf·m, 0.5 lbf·ft)	

TOOLS

Oil filter wrench
07HAA-PJ70101

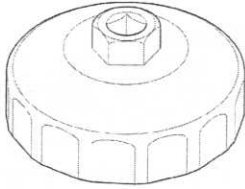

or 07AAA-PLCA100 (U.S.A. only)

Drive chain tool set
07HMH-MR10103

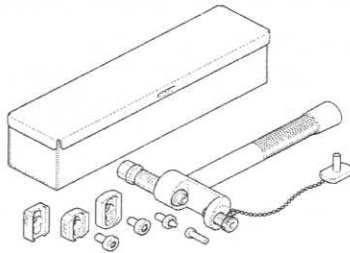

or 07HMH-MR1010C (U.S.A. only)

SCS connector
070PZ-ZY30100

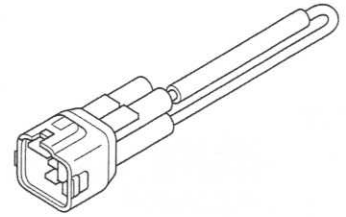

MAINTENANCE

MAINTENANCE SCHEDULE

Perform the Pre-ride inspection in the Owner's Manual at each scheduled maintenance period.

I: Inspect and Clean, Adjust, Lubricate or Replace if necessary. C: Clean. R: Replace. A: Adjust. L: Lubricate.

The following items require some mechanical knowledge. Certain items (particularly those marked * and **) may require more technical information and tools. Consult an authorized Honda dealer.

ITEMS	FREQUENCY	WHICHEVER COMES FIRST ↓	ODOMETER READING (NOTE 1)							REFER TO PAGE		
			X1,000 mi	0.6	4	8	12	16	20		24	
			X100 km	10	64	128	192	256	320		384	
EMISSION RELATED ITEMS	* FUEL LINE									4-5		
	* THROTTLE OPERATION									4-8		
	* AIR CLEANER	NOTE2								4-8		
	* SPARK PLUG									EVERY 16,000 mi (25,600 km) I, EVERY 32,000 mi (51,200 km) R	4-9	
	* VALVE CLEARANCE									4-13		
	ENGINE OIL									INITIAL = 600 mi (1,000 km) or 1 month: R, REGULAR = EVERY 8,000 mi (12,800 km) or 12 months: R	4-17	
	ENGINE OIL FILTER					R		R		R	4-17	
	RADIATOR COOLANT	NOTE4								R	4-19	
	* COOLING SYSTEM										4-20	
	* SECONDARY AIR SUPPLY SYSTEM										4-20	
	* EVAPORATIVE EMISSION CONTROL SYSTEM	NOTE3									4-21	
** EGCV CABLE									EVERY 16,000 mi (25,600 km) I	4-22		
NON-EMISSION RELATED ITEMS	DRIVE CHAIN									EVERY 500 mi (800 km) I, L	4-23	
	BRAKE FLUID	NOTE4							R		R	4-28
	BRAKE PADS WEAR										4-29	
	BRAKE SYSTEM										4-30	
	* BRAKE LIGHT SWITCH										4-31	
	* HEADLIGHT AIM										4-31	
	CLUTCH SYSTEM										4-31	
	SIDESTAND										4-32	
	* SUSPENSION										4-32	
	* NUTS, BOLTS, FASTENERS										4-35	
** WHEELS/TIRES										4-35		
** STEERING HEAD BEARINGS										4-36		

* Should be serviced by an authorized Honda dealer, unless the owner has proper tools and service data and is mechanically qualified.

** In the interest of safety, we recommended these items be serviced only by an authorized Honda dealer

NOTES:

- At higher odometer reading, repeat at the frequency interval established here.
- Service more frequently when riding in unusually wet or dusty areas.
- California type only.
- Replace every 2 years, or at indicated odometer interval, whichever comes first. Replacement requires mechanical skill.

FUEL LINE

FUEL TANK LIFTING

Remove the fuel tank cover (page 3-9).

Except california type: Release the fuel tank breather and drain hoses.

California type: Release the fuel tank drain hose.

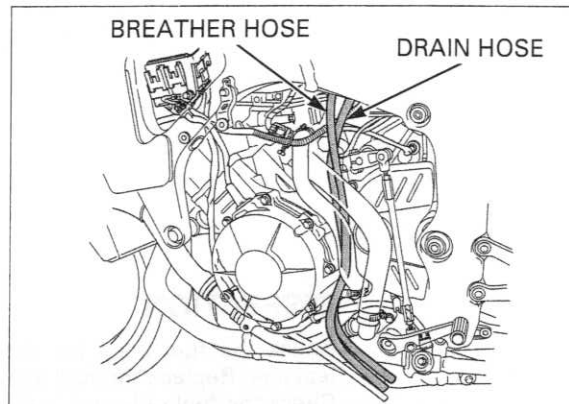

Remove the fuel tank mounting bolts and washers.

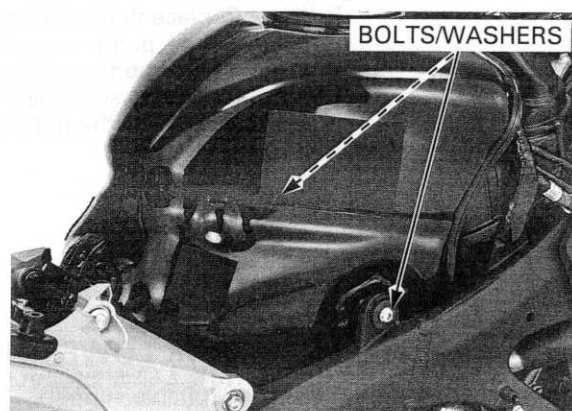

California type: Disconnect the fuel tank breather hose (to EVAP canister) from the hose joint.

California type shown:

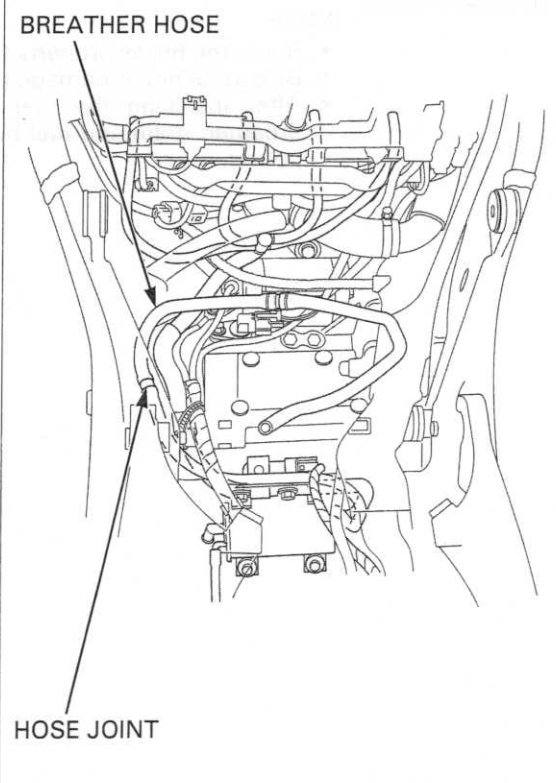

MAINTENANCE

Lift the front end of the fuel tank and support it using a suitable support as shown.

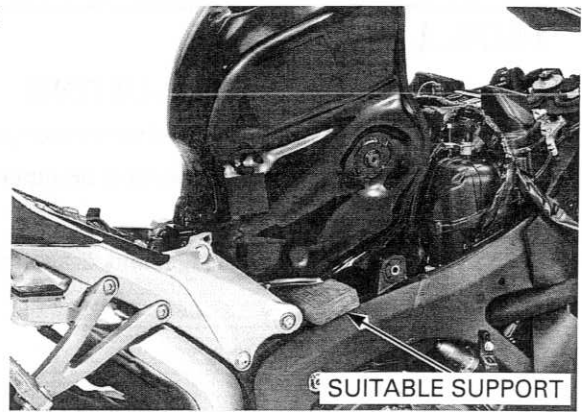

INSPECTION

Check the fuel lines for deterioration, damage or leakage. Replace the fuel line if necessary. Check the fuel rails and fuel line joint for damage or leakage. Replace them if necessary. Check the fuel pump mounting area for leakage. Replace the fuel pump packings if necessary. Check the primary/secondary injectors for damage or leakage. Replace them if necessary.

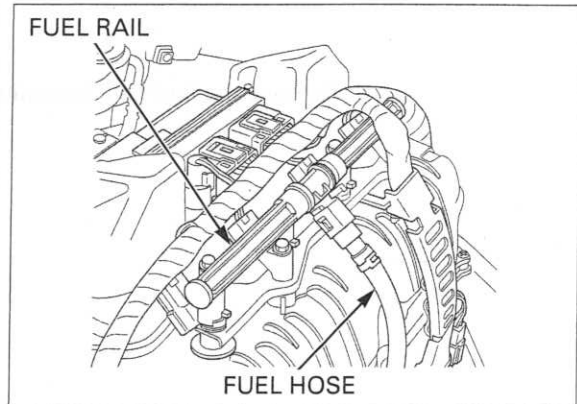

FUEL TANK LOWERING

Remove a suitable support.

Guide the breather hose and drain hose so as not to be kinked or bound.

Lower the fuel tank, leading the breather hose and drain hose to downward. Then close the fuel tank and route the breather and drain hoses.

NOTE:

- Route the hoses properly (page 1-21).
- Be careful not to damage the harness and hoses.
- After installing the fuel tank, make sure the breather, drain and fuel hoses are not kinked or bound.

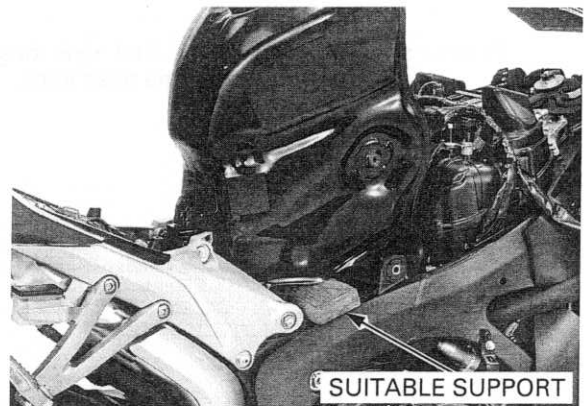

California type: Connect the fuel tank breather hose (to EVAP canister) to the hose joint securely.

California type shown:

BREATHER HOSE

HOSE JOINT

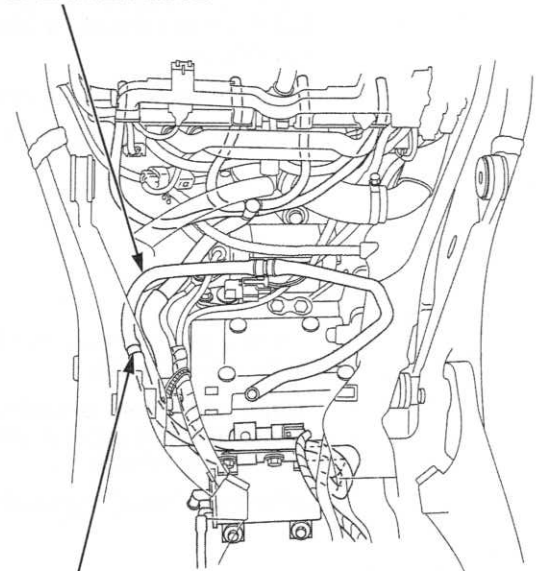

Install the washers and fuel tank mounting bolts.
Tighten the bolts to the specified torque.
TORQUE: 30 N·m (3.1 kgf·m, 22 lbf·ft)

BOLTS/WASHERS

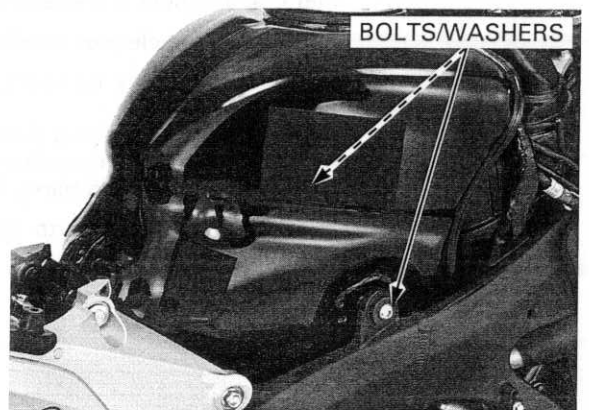

Route the hoses properly (page 1-21).

Install the removed parts in the reverse order of removal.

BREATHER HOSE

DRAIN HOSE

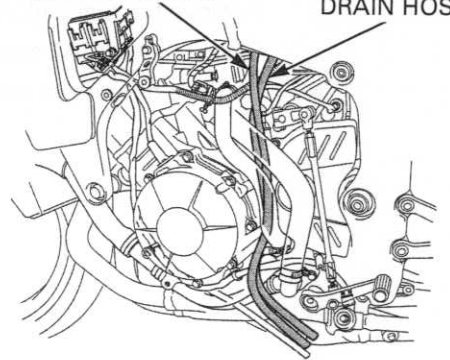

MAINTENANCE

THROTTLE OPERATION

Check for smooth throttle grip full opening and automatic full closing in all steering positions. Check the throttle cables and replace them if they are deteriorated, kinked or damaged. Lubricate the throttle cables, if throttle operation is not smooth.

Measure the freeplay at the throttle grip flange.

FREEPLAY: 2 – 4 mm (1/16 – 3/16 in)

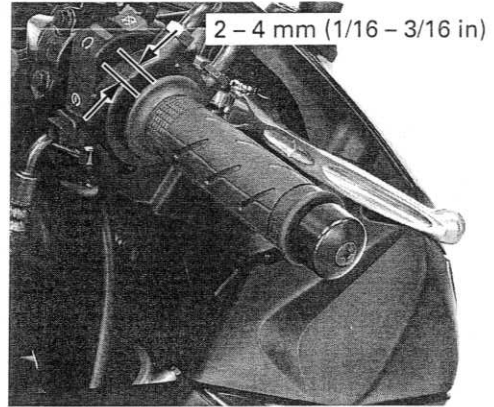

Throttle grip freeplay can be adjusted at either end of the throttle cable.

Minor adjustment is made with the upper adjuster. Adjust the freeplay by loosening the lock nut and turning the adjuster.

After adjustment, tighten the lock nut securely.

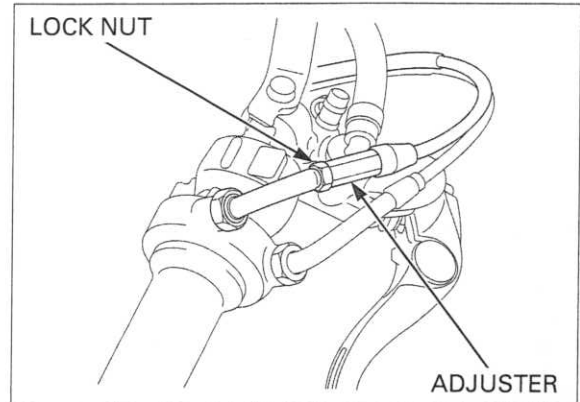

Major adjustment is made with the lower adjuster.

Remove the air cleaner housing (page 6-52).

Adjust the freeplay by loosening the lock nut and turning the adjuster.

After adjustment, tighten the lock nut securely.

Recheck the throttle operation.

Replace any damaged parts, if necessary.

Install the removed parts in the reverse order of removal.

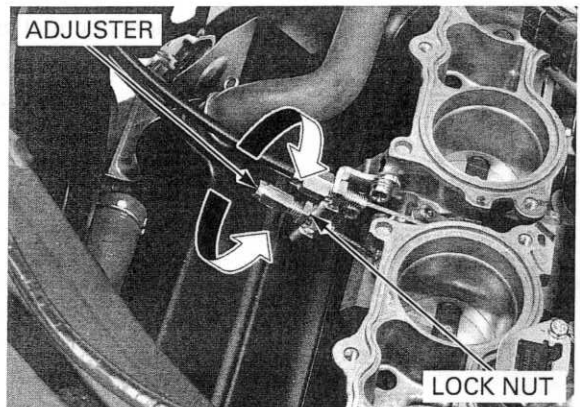

AIR CLEANER

Remove the fuel tank cover (page 3-9).

Disconnect the IAT sensor 2P (Gray) connector.

Remove the screws and ECM setting plate.

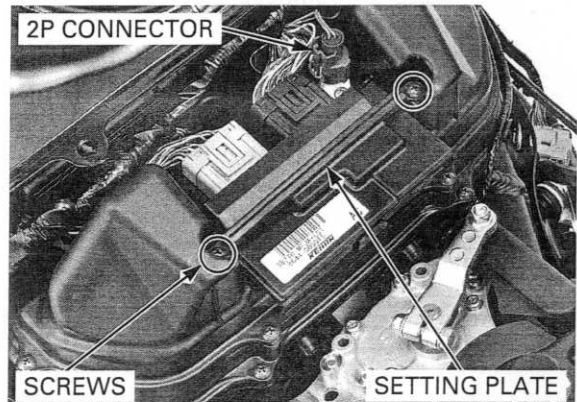

Be careful not to damage the ECM and wires.

Remove the screws and air cleaner housing upper cover by pulling up the ECM with connectors connected.



Loosen the screws and remove the air cleaner element as shown.

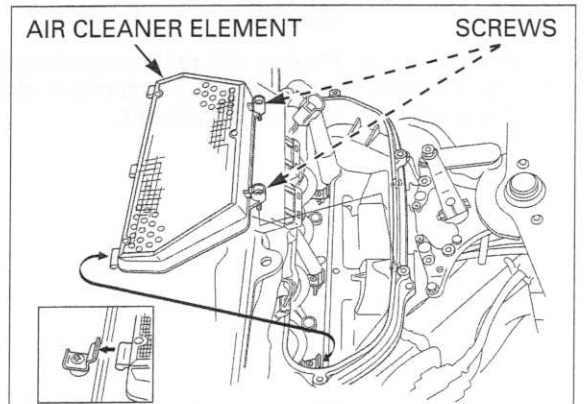

Clean the air cleaner element using compressed air from the throttle body side any time it is excessively dirty.

Installation is in the reverse order of removal.

TORQUE:

Air cleaner element mounting screw:

4.2 N·m (0.4 kgf·m, 3.1 lbf·ft)

ECM setting plate screw:

0.7 N·m (0.07 kgf·m, 0.5 lbf·ft)

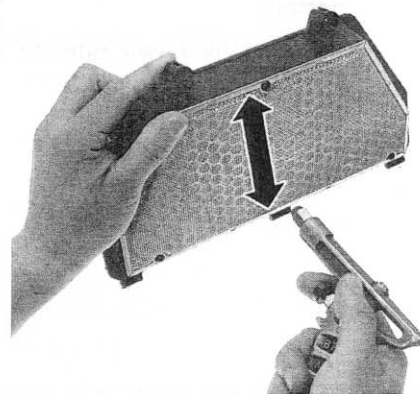

SPARK PLUG

REMOVAL

Remove the middle cowls (page 3-8).

Remove the screw and water pipe guard.

Remove the horn wire clamp and disconnect the fan motor 2P (Black) connector.

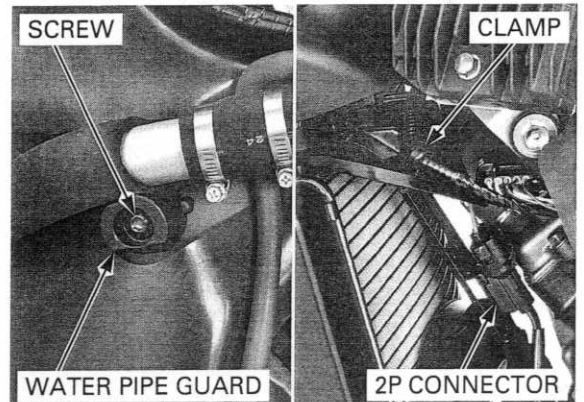

MAINTENANCE

Remove the radiator lower mounting bolt, washer and nut.

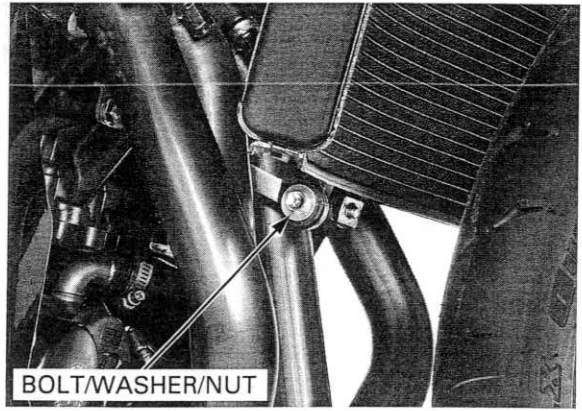

Remove the radiator upper mounting bolt and washer.

Be careful not to damage the radiator fins and radiator hoses.

Release the radiator grommet from the frame boss by moving the radiator to the right, then move the radiator downward.

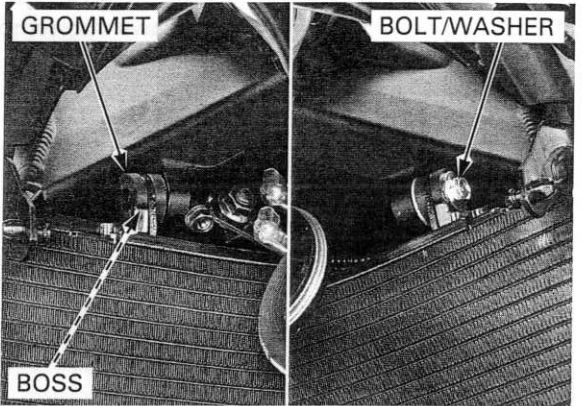

Disconnect the direct ignition coil 2P (White) connectors.

Remove the direct ignition coils from the spark plugs.

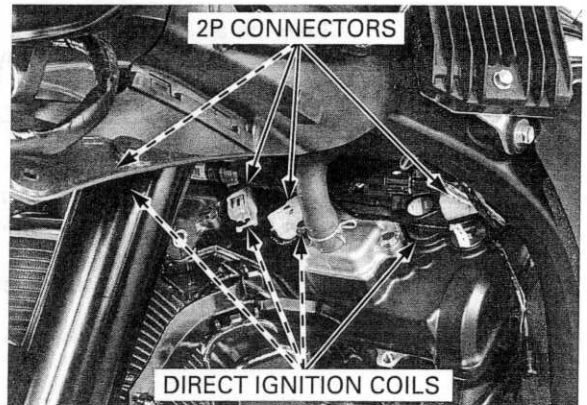

Clean around the spark plug bases with compressed air before removing, and be sure that no debris is allowed to enter the combustion chamber.

Remove the spark plug using the equipped spark plug wrench or an equivalent.

Inspect or replace as described in the maintenance schedule (page 4-4).

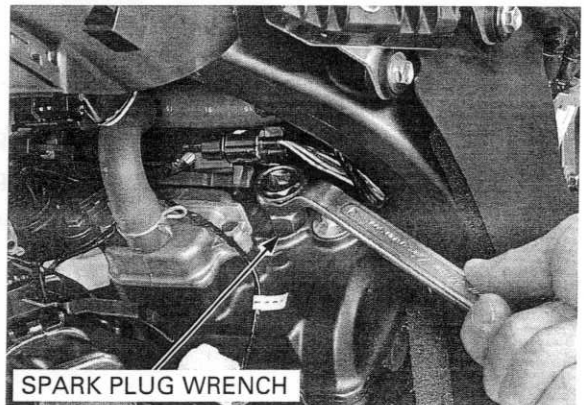

INSPECTION

Check the following and replace if necessary (recommended spark plug: page 4-2)

- Insulator for damage
- Electrodes for wear
- Burning condition, coloration

This motorcycle's spark plug is equipped with an iridium center electrode. Replace the spark plug if the electrodes are contaminated.

If the electrodes are contaminated with accumulated objects or dirt, replace the spark plug.

Always use specified spark plugs on this motorcycle.

Replace the plug if the center electrode is rounded as shown in the illustration.

SPECIFIED SPARK PLUG:

NGK: IMR9C-9HES

DENSO: VUH27D

To prevent damaging the iridium center electrode, use a wire type feeler gauge to check the spark plug gap.

Check the spark plug gap between the center and side electrodes with a wire type feeler gauge.

Make sure that the ϕ 1.0 mm (0.04 in) plug gauge does not insert between the gap.

Do not adjust the spark plug gap. If the gap is out of specification, replace with a new one.

If the gauge can be inserted into the gap, replace the plug with a new one.

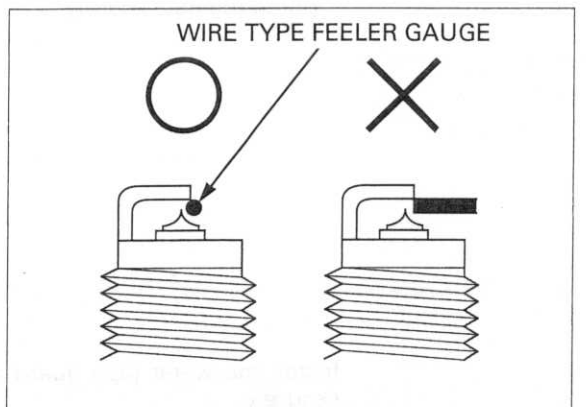
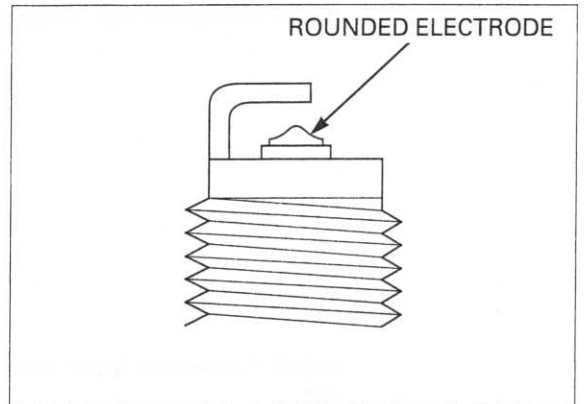
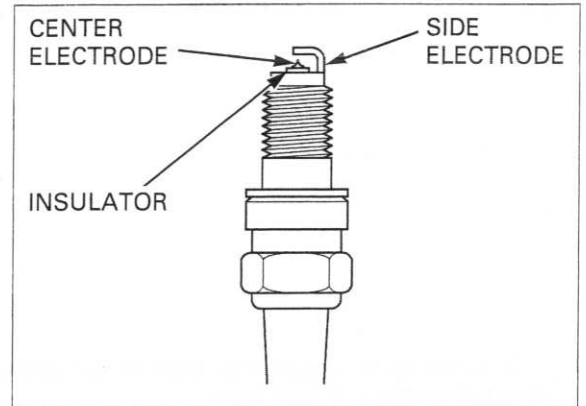

INSTALLATION

Install and hand tighten the spark plug to the cylinder head, then tighten the spark plug to the specified torque.

TORQUE: 16 N·m (1.6 kgf·m, 12 lbf·ft)

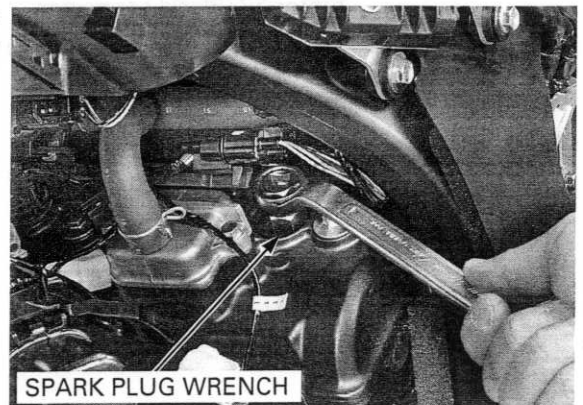

SPARK PLUG WRENCH

MAINTENANCE

Install the direct ignition coils.
Connect the direct ignition coil 2P (White) connectors correctly.

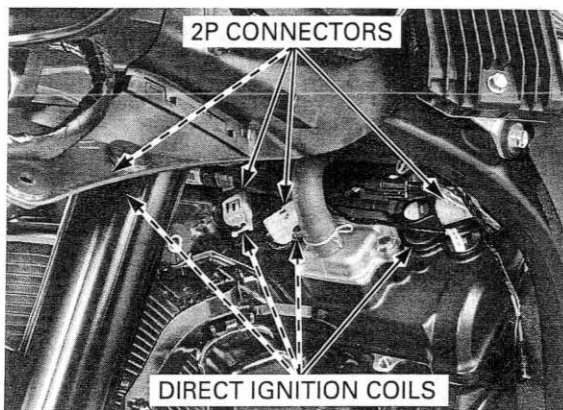

Be careful not to damage the radiator fins.

Install the radiator by aligning the grommet and frame boss.

Install the washer and radiator upper mounting bolt.

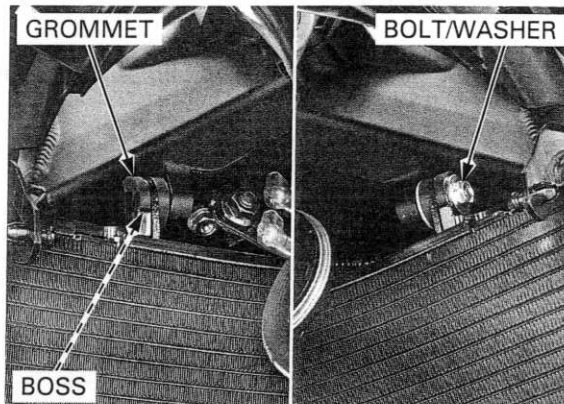

Install the radiator lower mounting bolt, washer and nut.

Tighten the nut securely.

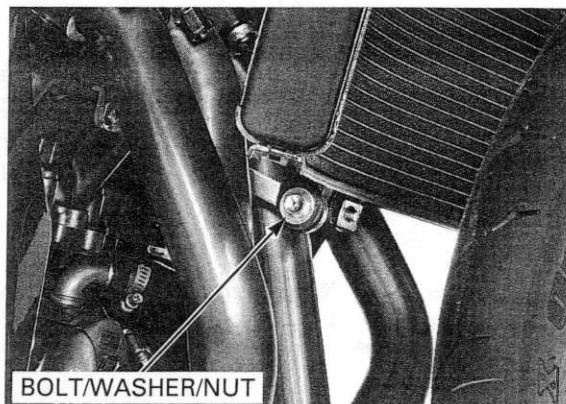

Install the water pipe guard and tighten the screw securely.

Install the horn wire clamp and connect the fan motor 2P (Black) connector.

Install the middle cowls (page 3-8).

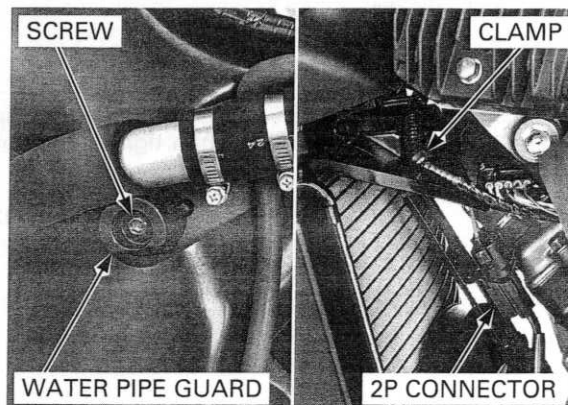

VALVE CLEARANCE

INSPECTION

NOTE:

Check the engine idle speed (page 6-67) after the valve clearance inspection.

Inspect and adjust the valve clearance while the engine is cold (below 35°C/95°F).

Remove the cylinder head cover (page 9-7).

Remove the timing hole cap and O-ring.

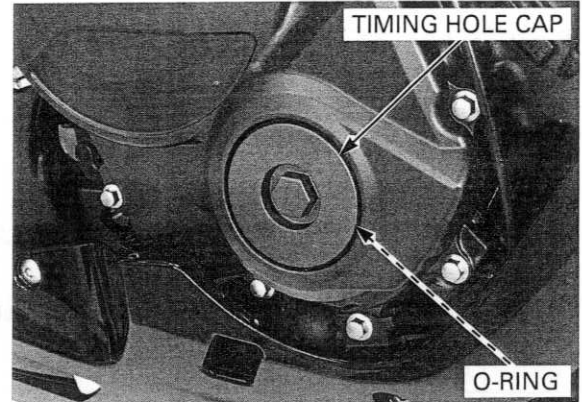

Turn the crankshaft clockwise, align the "T" mark with the index mark on the right crankcase cover.

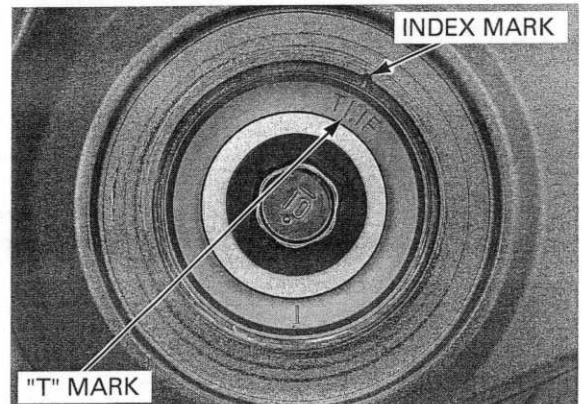

The timing marks ("IN" and "EX") on the cam sprockets must be flush with the cylinder head upper surface and facing outward as shown.

If the timing marks on the cam sprockets are facing inward, turn the crankshaft clockwise one full turn (360°) and realign the timing marks with the cylinder head surface so they are facing outward.

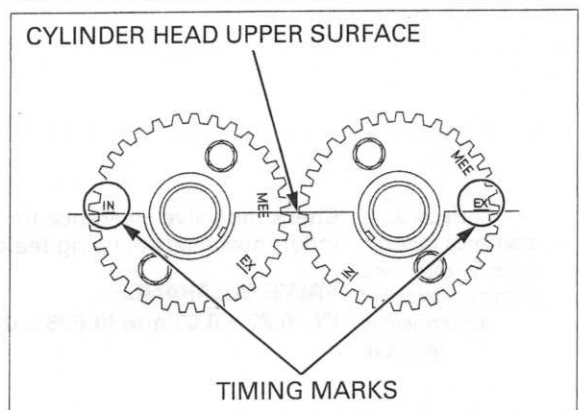

Insert the feeler gauge between the valve lifter and cam lobe.

Record the clearance for each valve for reference in shim selection if adjustment is required.

Check the valve clearance for the No.1 and No.3 cylinder intake valves using a feeler gauge.

VALVE CLEARANCE:

IN: 0.20 ± 0.03 mm (0.008 ± 0.001 in)

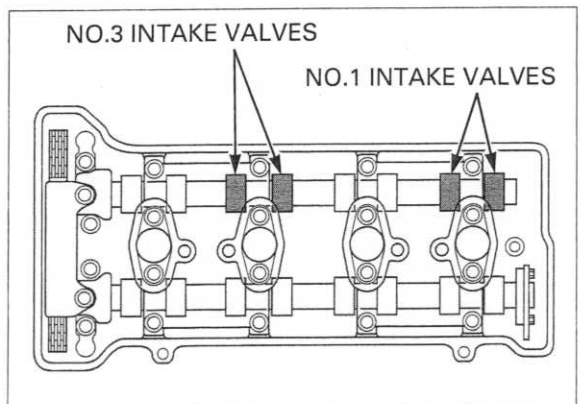

MAINTENANCE

Turn the crankshaft clockwise 1/2 turn (180°), align the index line so that it is facing up as shown.

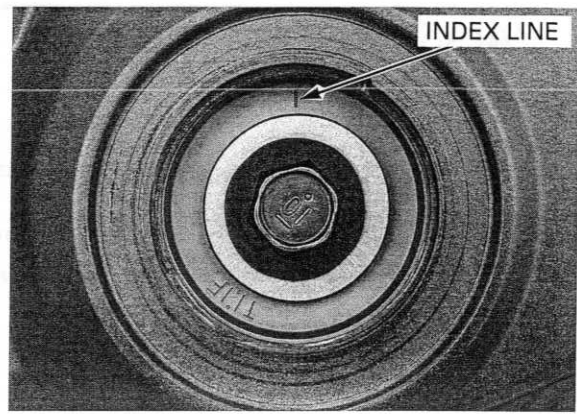

Record the clearance for each valve for reference in shim selection if adjustment is required.

Check the valve clearance for the No.2 and No.4 cylinder exhaust valves using a feeler gauge.

VALVE CLEARANCE:

EX: 0.28 ± 0.03 mm (0.011 ± 0.001 in)

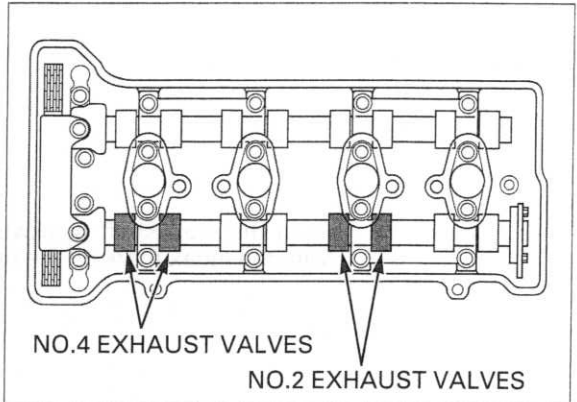

Turn the crankshaft clockwise 1/2 turn (180°), align the "T" mark with the index mark on the right crankcase cover.

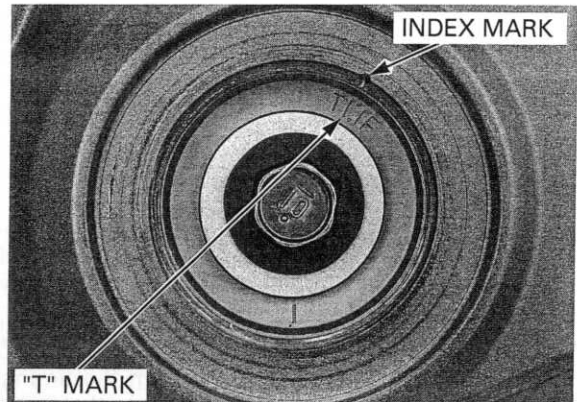

Record the clearance for each valve for reference in shim selection if adjustment is required.

Check the valve clearance for the No.2 and No.4 cylinder intake valves using feeler gauge.

VALVE CLEARANCE:

IN: 0.20 ± 0.03 mm (0.008 ± 0.001 in)

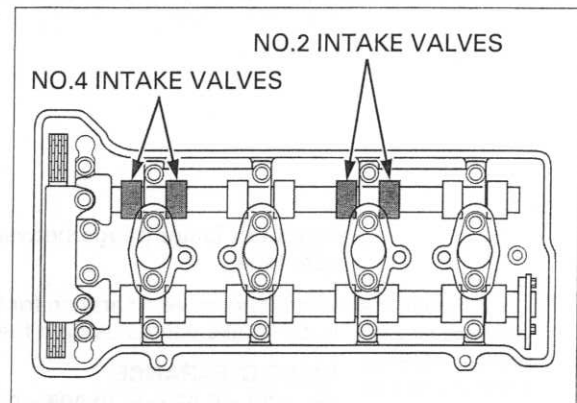

Turn the crankshaft clockwise 1/2 turn (180°), align the index line so that it is facing up as shown.

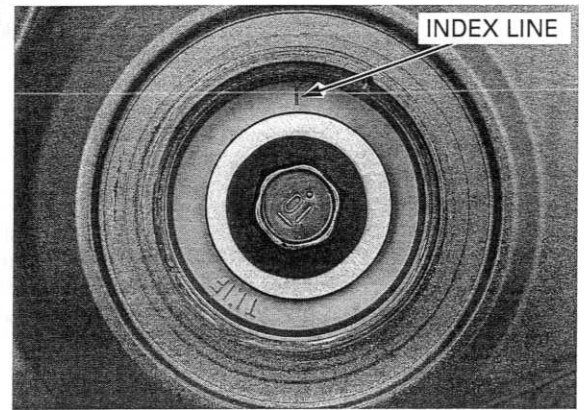

Record the clearance for each valve for reference in shim selection if adjustment is required.

Check the valve clearance for the No.1 and No.3 cylinder exhaust valves using a feeler gauge.

VALVE CLEARANCE:
EX: 0.28 ± 0.03 mm (0.011 ± 0.001 in)

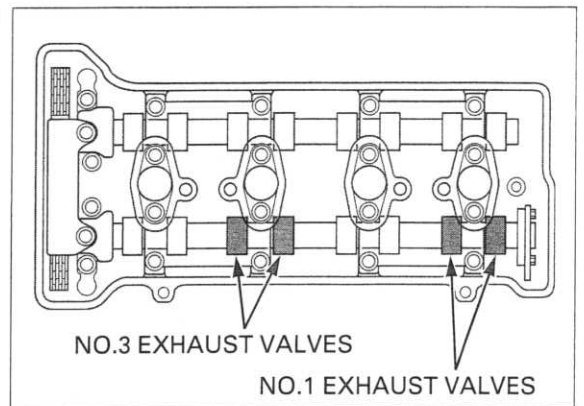

ADJUSTMENT

It is not necessary to remove the cam sprocket from the camshaft except when replacing the camshaft and/or cam sprocket.

Remove the camshafts (page 9-9).

Remove the valve lifters and shims.

- The shim may stick to the inside of the valve lifter. Do not allow the shims to fall into the crankcase.
- Mark all valve lifters and shims to ensure correct reassembly in their original locations.
- The valve lifter can be easily removed with a valve lapping tool or magnet.
- The shims can be easily removed with a tweezers or magnet.

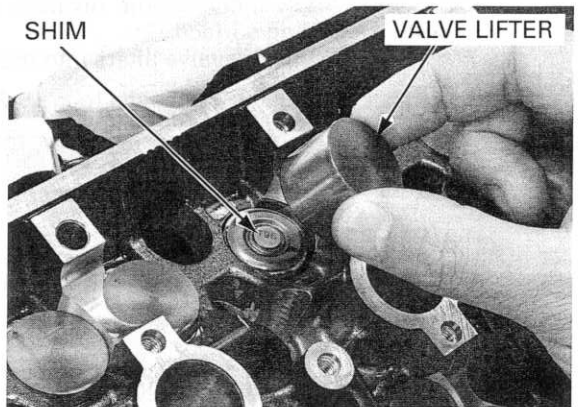

Clean the valve shim contact area in the valve lifter with compressed air.

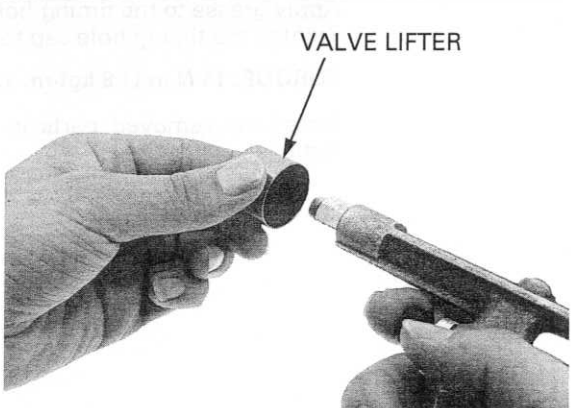

MAINTENANCE

Sixty-nine different thickness shims are available from the thinnest 1.200 mm thickness shim to the thickest 2.900 mm thickness shim in increments of 0.025 mm.

Measure the shim thickness and record it.

Calculate the new shim thickness using the equation below.

$$A = (B - C) + D$$

A: New shim thickness

B: Recorded valve clearance

C: Specified valve clearance

D: Old shim thickness

- Make sure of the correct shim thickness by measuring the shim by micrometer.
- Reface the valve seat if carbon deposit result in a calculated dimension of over 2.900 mm.

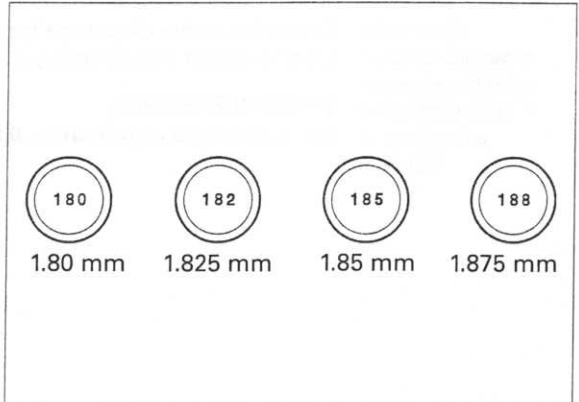
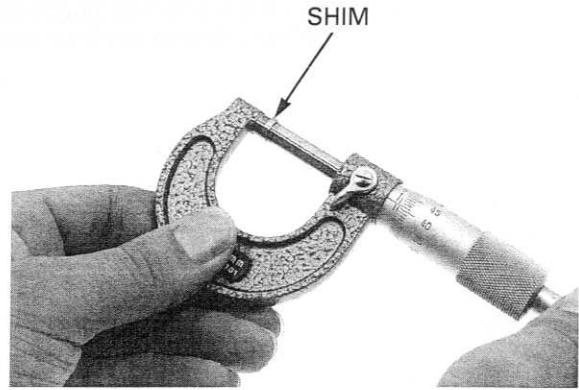

Install the shims and valve lifters in their original locations.

Install the newly selected shim on the valve spring retainer.

Apply molybdenum disulfide oil to the valve lifters sliding surface.

Install the valve lifters into the valve lifter holes.

Install the camshafts (page 9-28).

Rotate the camshafts by rotating the crankshaft clockwise several times.

Recheck the valve clearance.

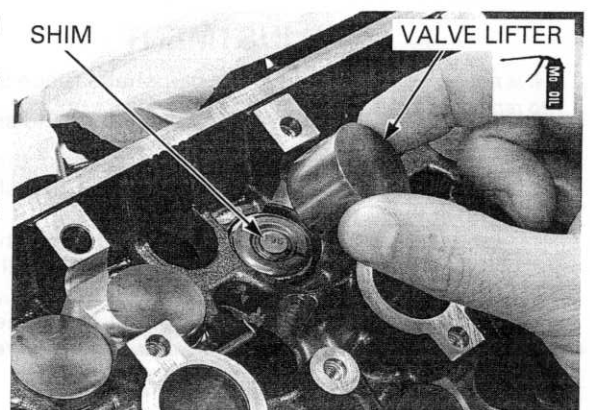

Apply oil to a new O-ring and install it to the timing hole cap.

Apply grease to the timing hole cap threads.

Tighten the timing hole cap to the specified torque.

TORQUE: 18 N·m (1.8 kgf·m, 13 lbf·ft)

Install the removed parts in the reverse order of removal.

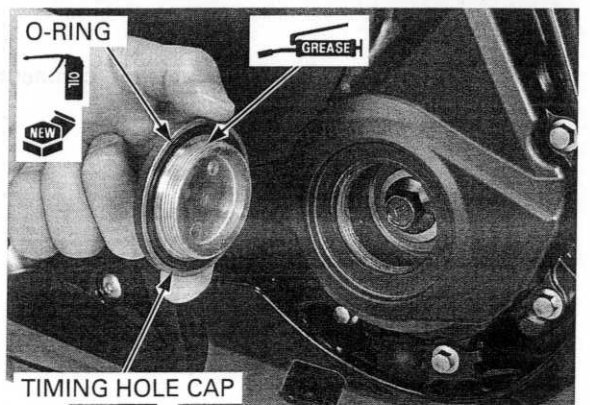

ENGINE OIL/OIL FILTER

OIL LEVEL INSPECTION

Start the engine and let it idle for 3 – 5 minutes.
 Stop the engine and wait 2 – 3 minutes.
 Hold the motorcycle in an upright position.

Check the oil level through the inspection window.

If the level is below the lower level line, remove the oil filler cap and fill the crankcase with the recommended oil up to the upper level line as following procedures:

Remove the oil filler cap and fill the recommended engine oil up to the upper level line.

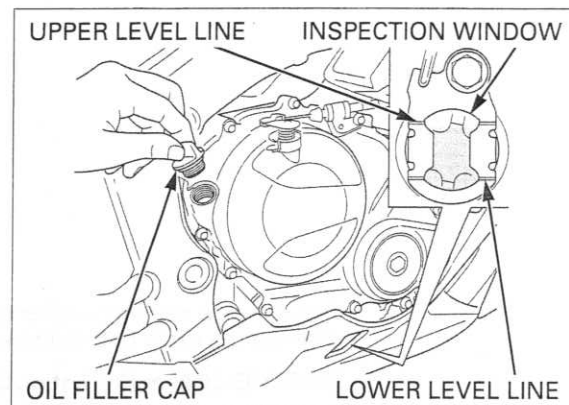

Other viscosities shown in the chart may be used when the average temperature in your riding area is within the indicated range.

RECOMMENDED ENGINE OIL:

Pro Honda GN4 4-stroke oil (U.S.A. and Canada) or equivalent motor oil
API service classification: SG or Higher
JASO T 903 standard: MA
Viscosity: SAE 10W-30

Reinstall the oil filler cap.

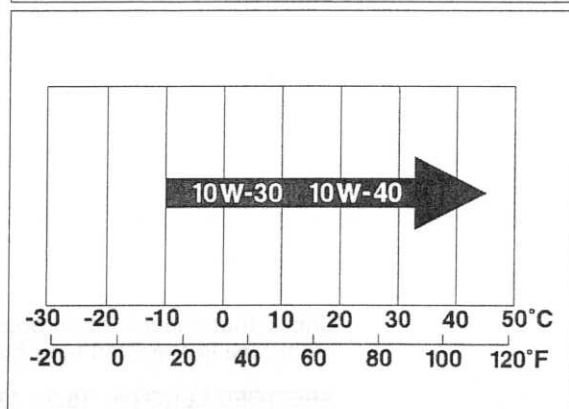

ENGINE OIL & FILTER CHANGE

Remove the lower cowl (page 3-6).
 Hold the motorcycle in an upright position.
 Remove the oil filler cap.

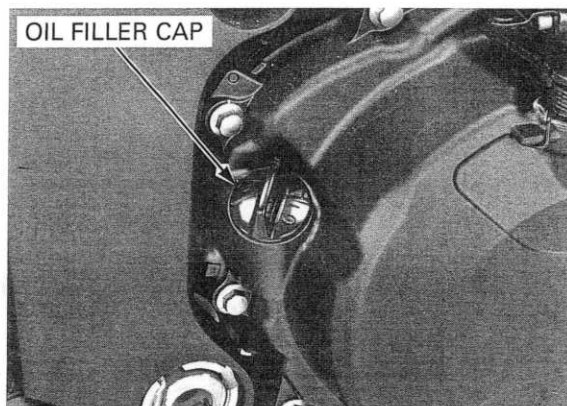

Remove the drain bolt and sealing washer, drain the oil completely.

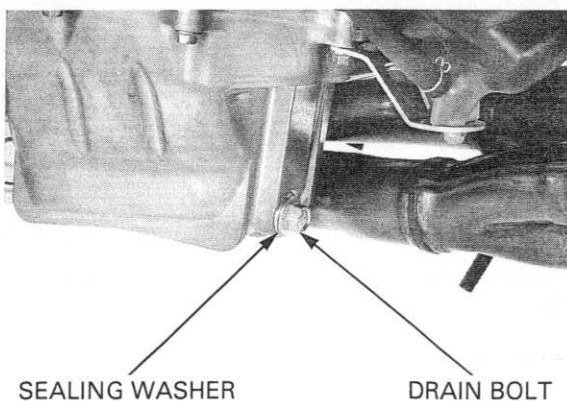

MAINTENANCE

Remove the oil filter cartridge using the special tool.

TOOL:

Oil filter wrench

07HAA-PJ70101 or
07AAA-PLCA100
(U.S.A. only)

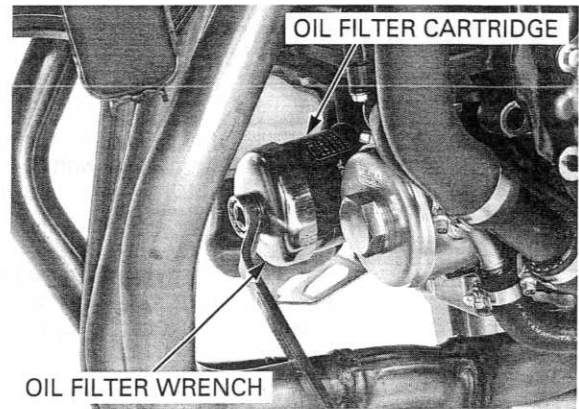

Install a new sealing washer onto the drain bolt.
Tighten the drain bolt to the specified torque.

TORQUE: 30 N·m (3.1 kgf·m, 22 lbf·ft)

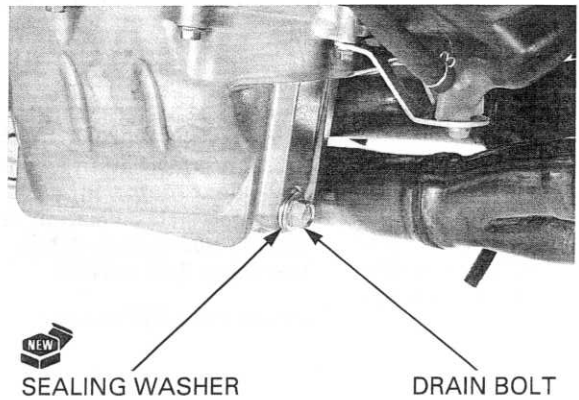

Check that the oil filter boss protrusion from the crankcase is specified length as shown.

SPECIFIED LENGTH: 16.0 – 17.0 mm (0.63 – 0.67 in)

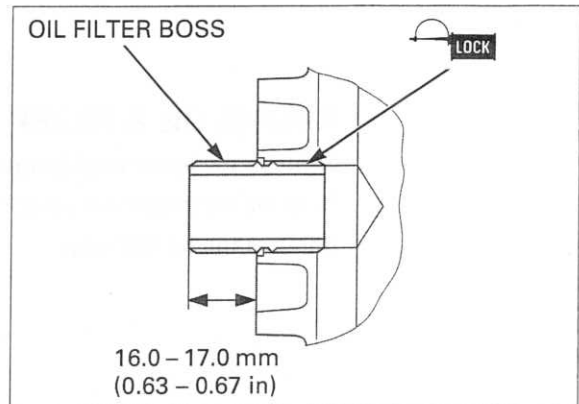

Apply oil to new oil filter cartridge threads and O-ring.

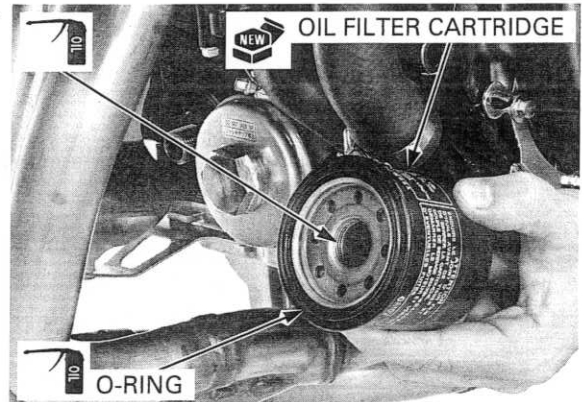

Install the oil filter cartridge and tighten it to the specified torque.

TOOL:

Oil filter wrench

07HAA-PJ70101 or
07AAA-PLCA100
(U.S.A. only)

TORQUE: 26 N·m (2.7 kgf·m, 19 lbf·ft)

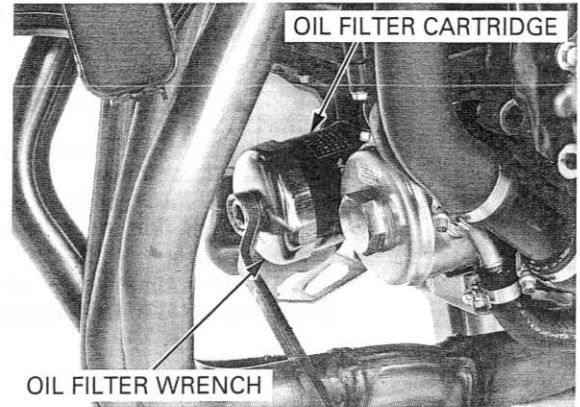

Fill the crankcase with recommended engine oil.

ENGINE OIL CAPACITY:

2.7 liter (2.9 US qt, 2.4 Imp qt) after draining

2.8 liter (3.0 US qt, 2.5 Imp qt) after oil filter change

Check that the O-ring on the oil filler cap is in good condition, and replace it if necessary. Install the oil filler cap.

Start the engine and let it idle for 3 – 5 minutes. Stop the engine and wait 2 – 3 minutes and recheck the oil level.

Check that there are no oil leaks.

Install the lower cowl (page 3-6).

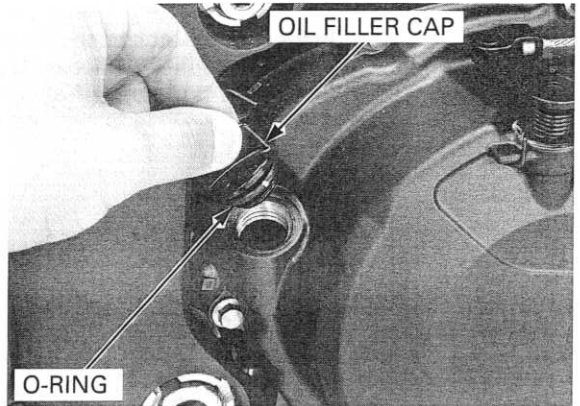

RADIATOR COOLANT

Check the coolant level of the reserve tank with the engine running at normal operating temperature.

The level should be between the "UPPER" and "LOWER" level lines.

If necessary, add recommended coolant.

RECOMMENDED ANTIFREEZE:

Pro Honda HP Coolant or an equivalent high quality ethylene glycol antifreeze containing silicate free corrosion inhibitors

Remove the lower cowl (page 3-6).

Remove the reserve tank filler cap and fill to the "UPPER" level line with 1:1 mixture of distilled water and antifreeze.

Reinstall the filler cap.

Install the lower cowl (page 3-6).

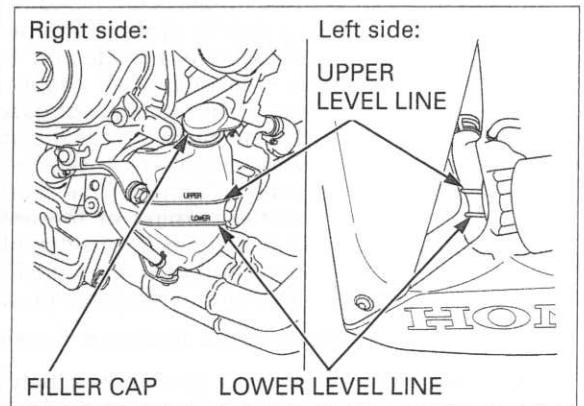

MAINTENANCE

COOLING SYSTEM

Remove the following:

- Lower cowl (page 3-6)
- Middle cowls (page 3-8)

Check the radiator air passages for clogging or damage.

Straighten bent fins, and remove insects, mud or other obstructions with compressed air or low water pressure.

Replace the radiator if the air flow is restricted over more than 20 % of the radiating surface.

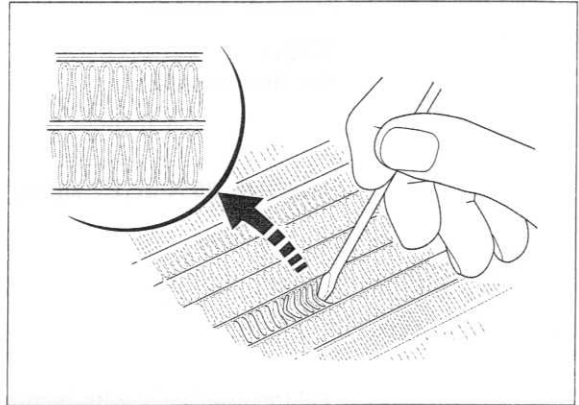

Inspect the water hoses for cracks or deterioration, and replace them if necessary.

Check the tightness of all hose clamps and fasteners.

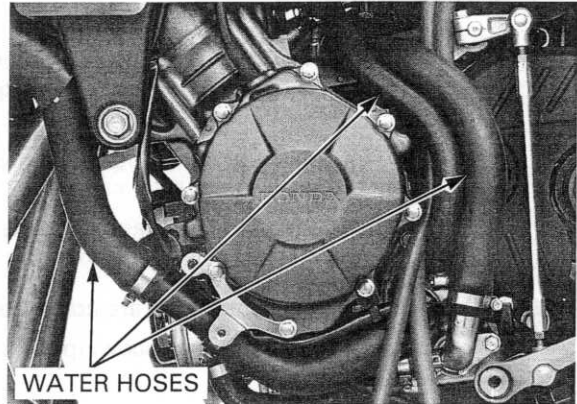

SECONDARY AIR SUPPLY SYSTEM

- This model is equipped with a built-in secondary air supply system. The pulse secondary air supply system is located on the cylinder head cover.
- The secondary air supply system introduces filtered air into exhaust gases in the exhaust port. The secondary air is drawn into the exhaust port whenever there is negative pressure pulse in the exhaust system. This charged secondary air promotes burning of the unburned exhaust gases and changes a considerable amount of hydrocarbons and carbon monoxide into relatively harmless carbon dioxide and water.

Remove the air cleaner housing (page 6-52).

If the hoses show any signs of heat damage, inspect the PAIR check valves for damage.

Check the PAIR hoses between the PAIR control solenoid valve and cylinder head cover for deterioration, damage or loose connections. Make sure that the hoses are not cracked.

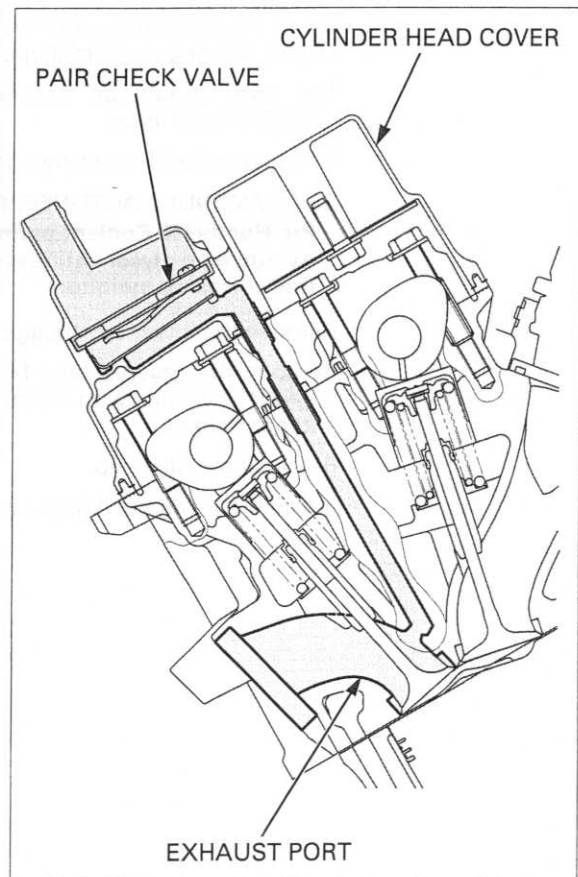

Check the air suction hose between the air cleaner housing and PAIR control solenoid valve for deterioration, damage or loose connections. Check that the hoses are not kinked, pinched or cracked.

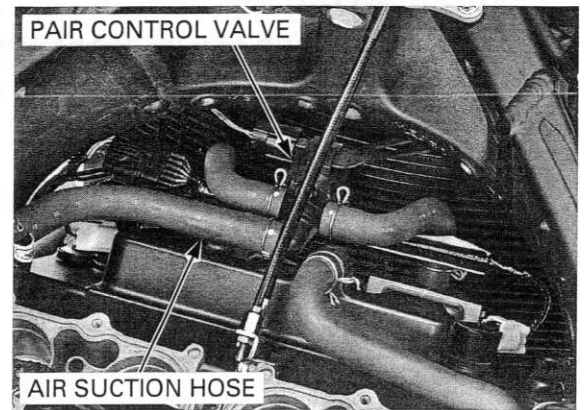

EVAPORATIVE EMISSION CONTROL SYSTEM (CALIFORNIA TYPE)

Check the hoses between the fuel tank, EVAP canister, EVAP purge control solenoid valve for deterioration, damage or loose connection.

Check the EVAP canister for clacks or other damage.

Refer to the Cable & Harness Routing for hose connections (page 1-34).

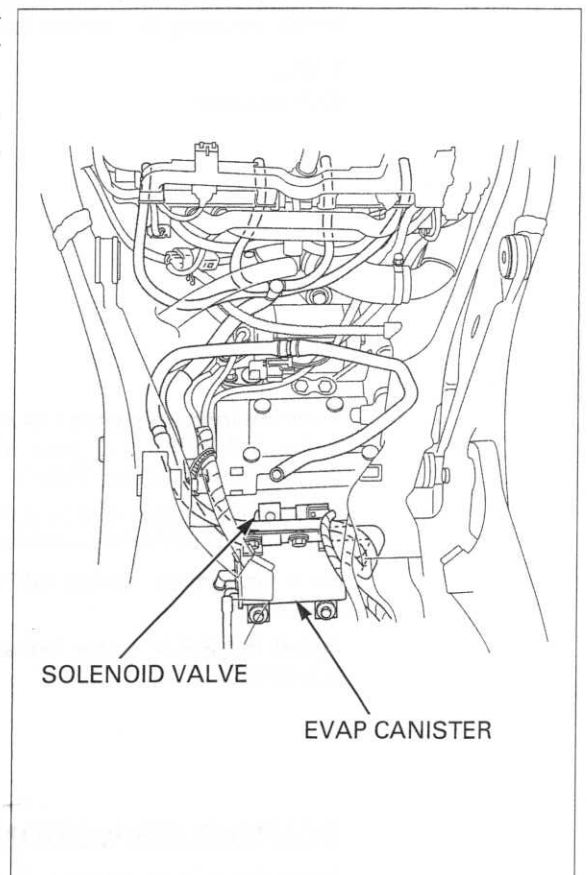

EGCV CABLE

OPERATING INSPECTION

Remove the following:

- Seat (page 3-4)
- Lower cowl (page 3-6)

Remove the bolts, nuts and EGCV cover.

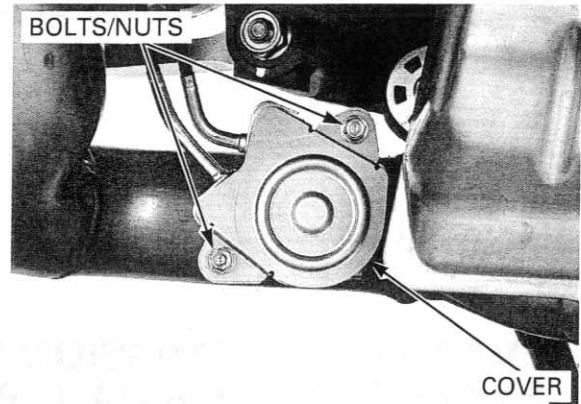

Remove the dummy connector and short the DLC terminals using the special tool.

TOOL:

SCS connector

070PZ-ZY30100

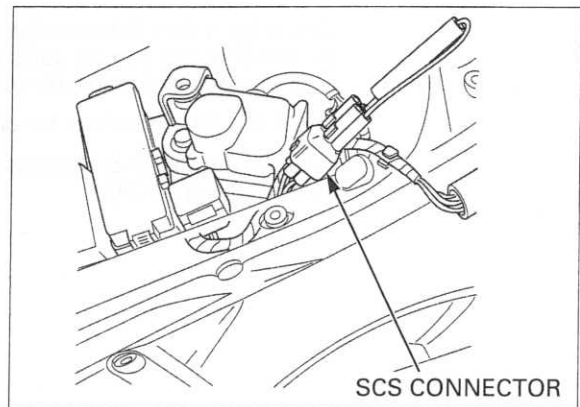

Turn the ignition switch ON and make sure that the pulley index line is aligned with the EGCV housing projecting portion as shown.

If the pulley index line is not within the tolerance, adjust the EGCV control cable (page 4-23).

Turn the ignition switch OFF and remove the SCS connector.

Install the EGCV cover, bolts and tighten the nuts securely.

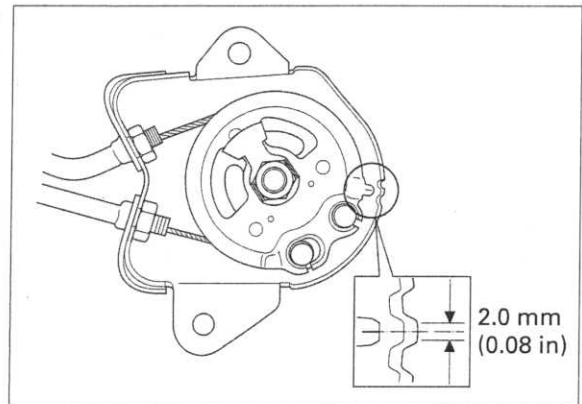

BEARING INSPECTION

Move the exhaust valve pulley to the rotative direction with your hand, check the exhaust valve shaft for excessive play.

If there is excessive play to the rotative direction, replace the exhaust pipe (page 3-24).

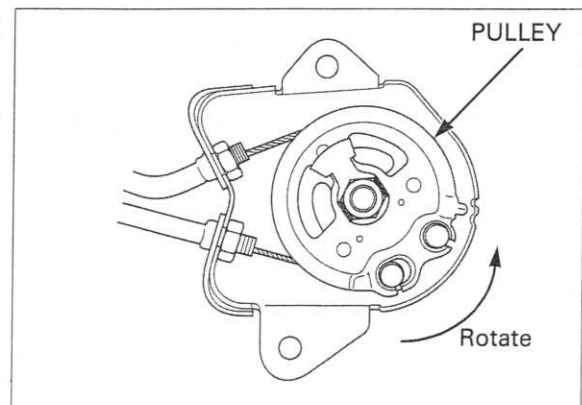

CABLE ADJUSTMENT

1. Short the DLC using the special tool (page 6-15).
2. Loosen the adjusting nut and adjust the pulley position by turning the adjusting nut.
3. Tighten the lock nut securely.

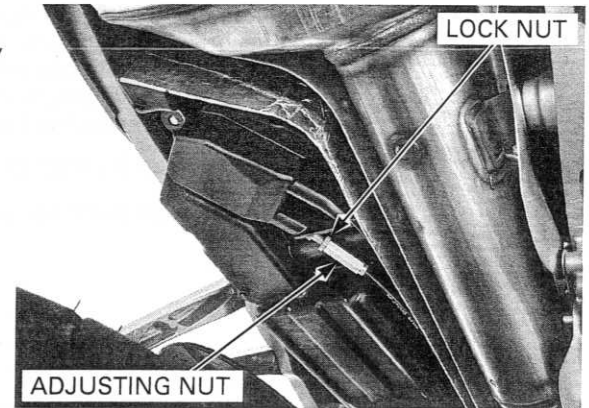

4. Remove the SCS connector from the DLC, then reinstall it.

Make sure that the pulley index line is aligned with the EGCV housing tolerance as shown.

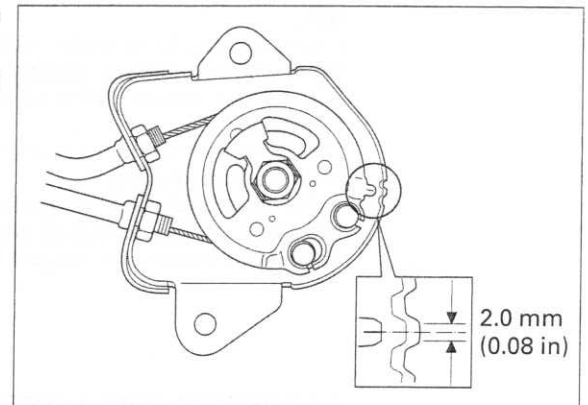

DRIVE CHAIN

DRIVE CHAIN SLACK INSPECTION

Never inspect and adjust the drive chain while the engine is running.

Turn the ignition switch OFF, place the motorcycle on its sidestand and shift the transmission into neutral.

Check the slack in the drive chain lower run midway between the sprockets.

DRIVE CHAIN SLACK: 30 – 40 mm (1.2 – 1.6 in)

NOTICE

Excessive chain slack, 50 mm (2.0 in) or more, may damage the frame.

Lubricate the drive chain with #80 – 90 gear oil or chain lubricant designed specifically for use with O-ring chains. Wipe off the excess oil or chain lubricant.

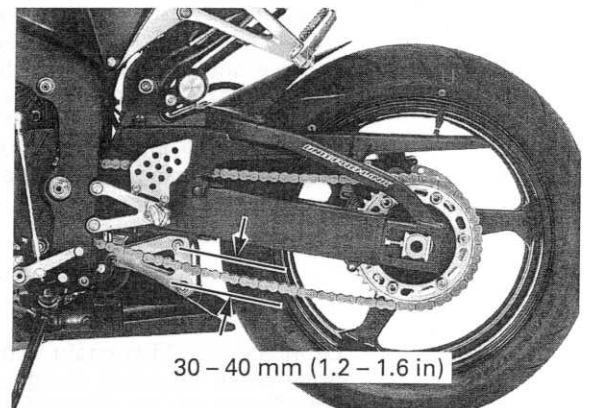

MAINTENANCE

ADJUSTMENT

Loosen the rear axle nut.
Loosen the lock nuts and turn the adjusting bolts until the correct drive chain slack is obtained.
Make sure the index marks on both adjusting plates are aligned with the swingarm index mark.
Tighten the rear axle nut to the specified torque.

TORQUE: 113 N·m (11.5 kgf·m, 83 lbf·ft)

Hold the adjusting bolts and tighten the lock nuts.

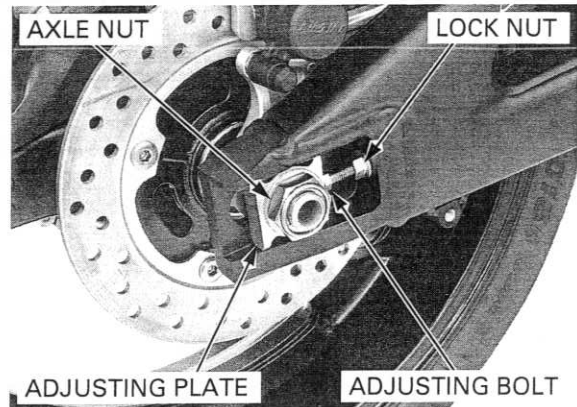

Recheck the drive chain slack and free wheel rotation.

Lubricate the drive chain with #80 – 90 gear oil or drive chain lubricant designed specifically for use with O-ring chains. Wipe off the excess oil or chain lubricant.

Check the drive chain wear indicator label attached on the left swingarm.

If the drive chain adjusting plate index mark reaches red zone of the indicator label, replace the drive chain with a new one (page 4-26).

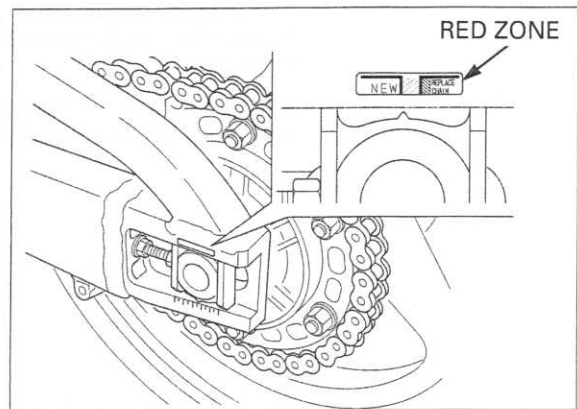

CLEANING AND LUBRICATION

Clean the chain with non-flammable or high flash point solvent and wipe it dry.

Be sure the chain has dried completely before lubricating.

Inspect the drive chain for possible damage or wear. Replace any chain that has damaged rollers, loose fitting links, or otherwise appears unserviceable.

Installing a new chain on badly worn sprockets will cause the new chain to wear quickly.

Inspect and replace sprocket as necessary.

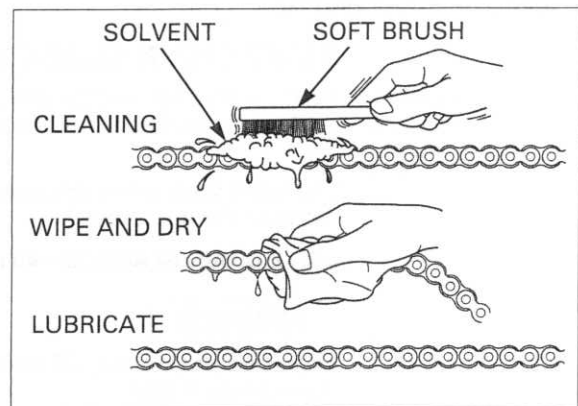

Lubricate the drive chain with #80 – 90 gear oil or drive chain lubricant designed specifically for use with O-ring chains. Wipe off the excess oil or chain lubricant.

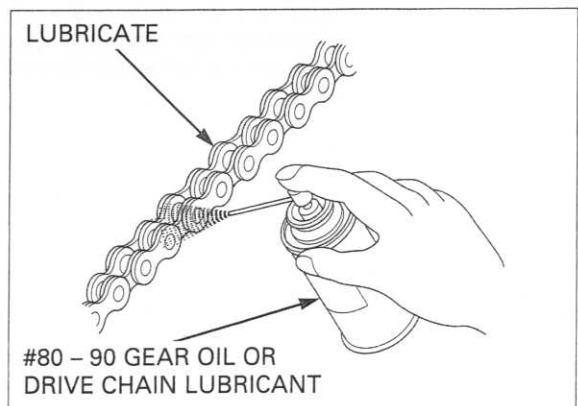

SPROCKET INSPECTION

Remove the drive sprocket cover (page 8-5).

Inspect the drive and driven sprocket teeth for wear or damage, replace if necessary.

Never use a new drive chain on worn sprockets.

Both chain and sprockets must be in good condition, or the new replacement chain will wear rapidly.

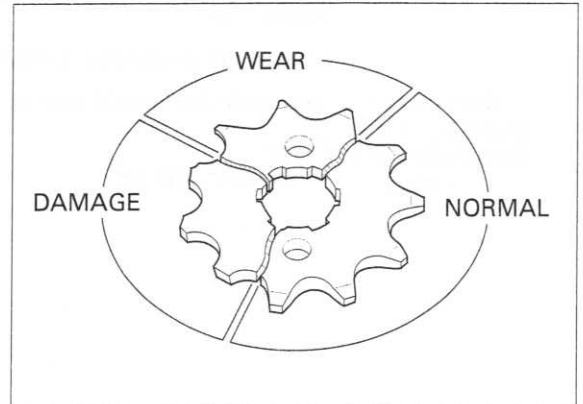

Check the attaching bolts and nuts on the drive and driven sprockets.
If any are loose, torque them.

TORQUE:

Drive sprocket bolt: 54 N·m (5.5 kgf·m, 40 lbf·ft)

Driven sprocket nut: 64 N·m (6.5 kgf·m, 47 lbf·ft)

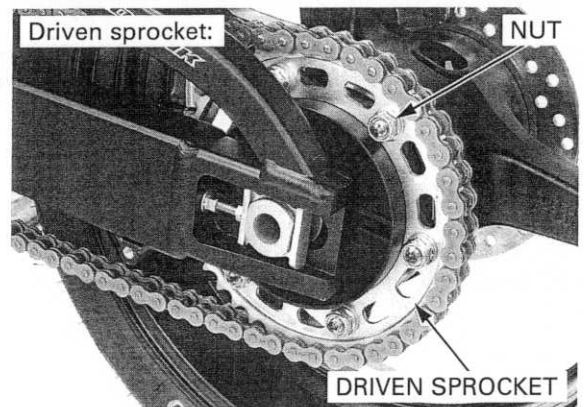
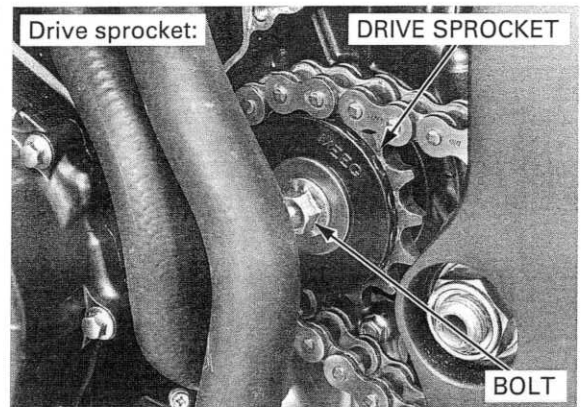

MAINTENANCE

REPLACEMENT

This motorcycle uses a drive chain with a staked master link.

Loosen the drive chain (page 4-24).

Assemble the special tool as shown.

TOOL:
Drive chain tool set

**07HMH-MR10103 or
07HMH-MR1010C
(U.S.A. only)**

When using the special tool, follow the manufacturer's instruction.

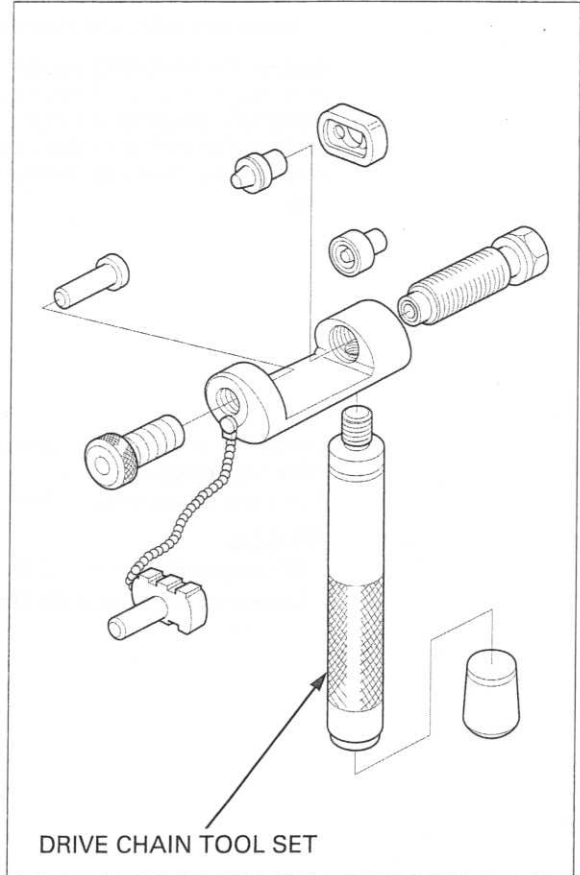

Locate the crimped pin ends of the master link from the outside of the chain, and remove the link with the drive chain tool set.

TOOL:
Drive chain tool set

**07HMH-MR10103 or
07HMH-MR1010C
(U.S.A. only)**

Remove the drive chain.

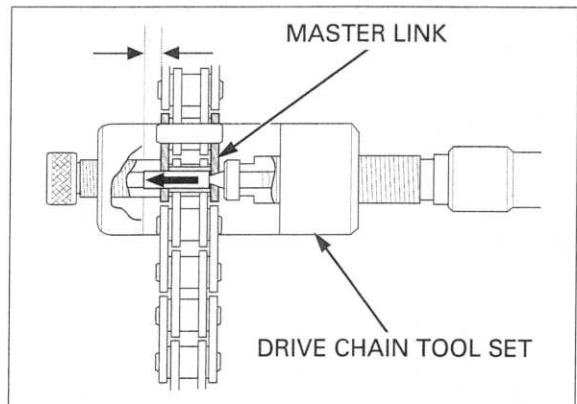

Include the master link when you count the drive chain links.

Remove the excess drive chain links from the new drive chain with the drive chain tool set.

STANDARD LINKS: 112 LINKS

REPLACEMENT CHAIN

DID: DID525HV KAI-112YB

RK: RK525ROZ6-112LJFZ

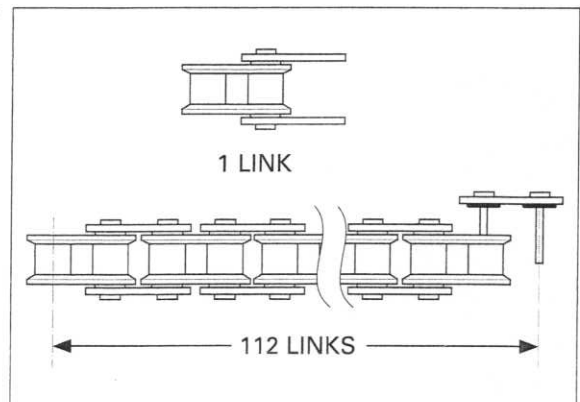

- Never reuse the old drive chain, master link, master link plate and O-rings.

Insert the master link from the inside of the drive chain, and install the plate with the identification mark facing the outside.

Assemble the new master link, O-rings and plate.

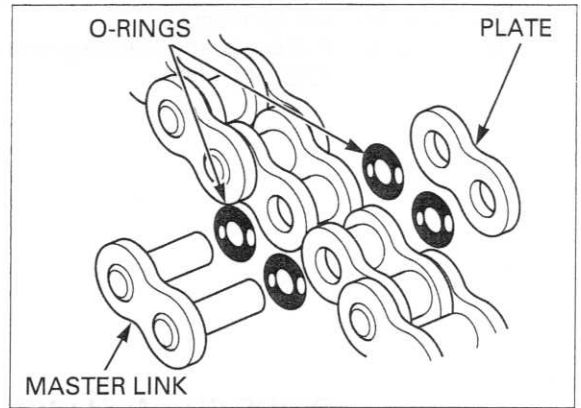

Assemble and set the drive chain tool set.

TOOL:

Drive chain tool set

07HMH-MR10103 or
07HMH-MR1010C
(U.S.A. only)

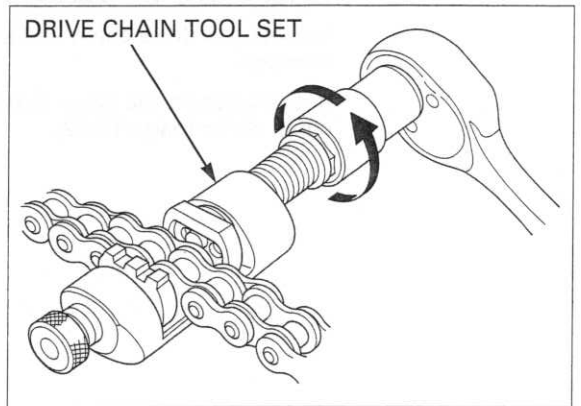

Make sure that the master link pins are installed properly.
Measure the master link pin length projected from the plate.

STANDARD LENGTH:

DID: 1.15 – 1.55 mm (0.045 – 0.061 in)

RK: 1.2 – 1.4 mm (0.05 – 0.06 in)

Stake the master link pins.

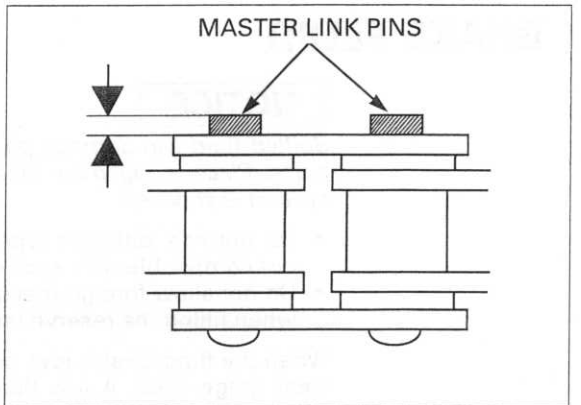

Make sure that the pins are staked properly by measuring the diameter of the staked area using a slide caliper.

DIAMETER OF THE STAKED AREA:

DID: 5.50 – 5.80 mm (0.217– 0.228 in)

RK: 5.30 – 5.70 mm (0.209 – 0.224 in)

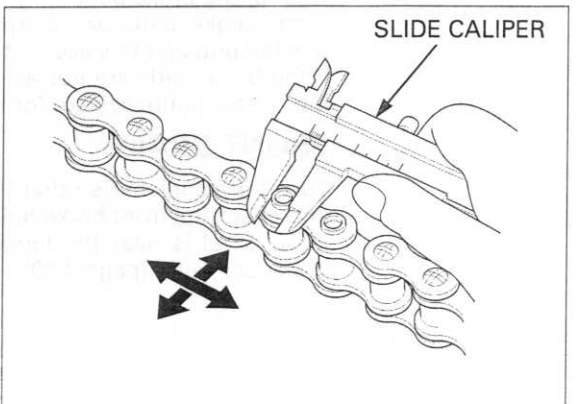

MAINTENANCE

A drive chain with a clip-type master link must not be used. After staking, check the staked area of the master link for cracks. If there is any cracking, replace the master link, O-rings and plate.

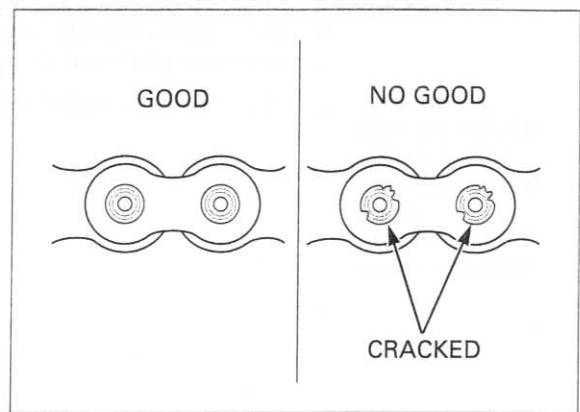

DRIVE CHAIN SLIDER

Inspect the drive chain slider for excessive wear or damage.

If it is worn to the wear indicator, replace the drive chain slider (page 15-22).

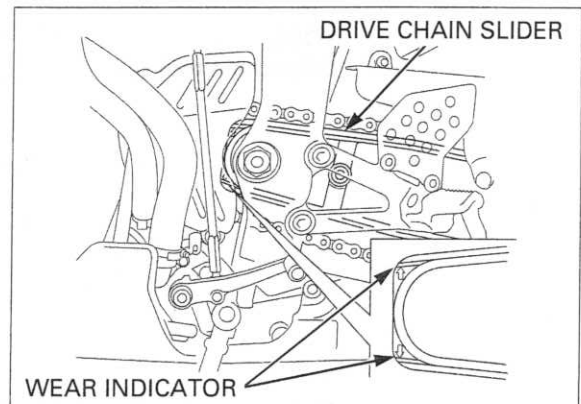

BRAKE FLUID

NOTICE

Spilled fluid can damage painted, plastic or rubber parts. Place a rag over these parts whenever the system is serviced.

- Do not mix different types of fluid, as they are not compatible with each other.
- Do not allow foreign material to enter the system when filling the reserve tank.

When the fluid level is low, check the brake pads for wear (page 4-29). A low fluid level may be due to wear of the brake pads.

If the brake pads are worn, the caliper piston is pushed out, and this accounts for a low fluid level.

If the brake pads are not worn and the fluid level is low, check entire system for leaks (page 4-30).

FRONT BRAKE

Turn the handlebar so that the reserve tank is level and check the front brake fluid level.

If the level is near the lower level line, check the brake pad wear (page 4-29).

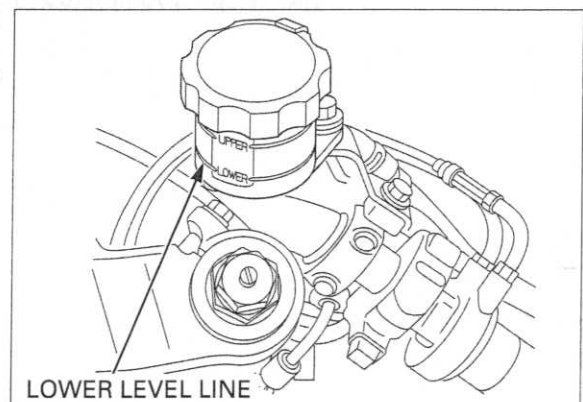

REAR BRAKE

Place the motorcycle on a level surface, and support it in an upright position.
Check the rear brake fluid level.
If the level is near the lower level line, check the brake pad wear (page 4-29).

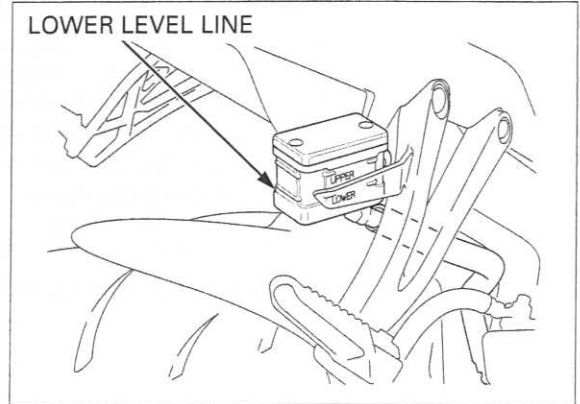

BRAKE PADS WEAR

FRONT BRAKE PADS

Check the brake pads for wear.
Replace the brake pads if either pad is worn to the bottom of wear limit groove.
For brake pad replacement (page 16-9).

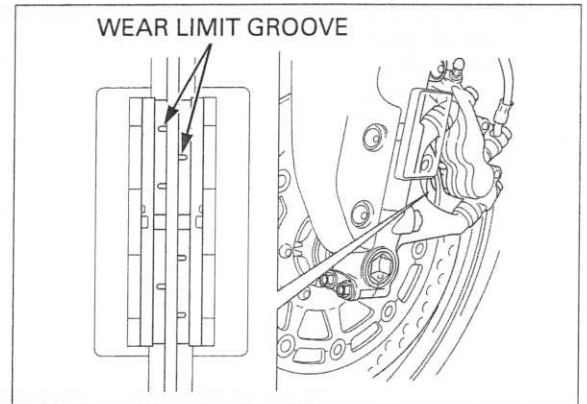

REAR BRAKE PADS

Check the brake pads for wear.
Replace the brake pads if either pad is worn to the bottom of wear limit groove.
For brake pad replacement (page 16-11).

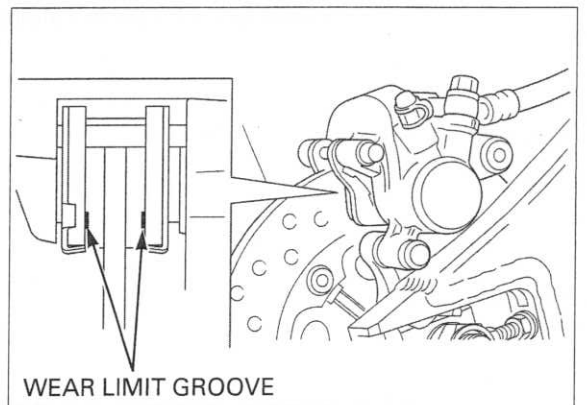

BRAKE SYSTEM

INSPECTION

Firmly apply the brake lever or pedal, and check that no air has entered the system.

If the lever or pedal feels soft or spongy when operated, bleed the air from the system (page 16-8).

Inspect the brake hose and fittings for deterioration, cracks and signs of leakage.

Tighten any loose fittings.

Replace hoses and fittings as required.

For brake air bleeding (page 16-8).

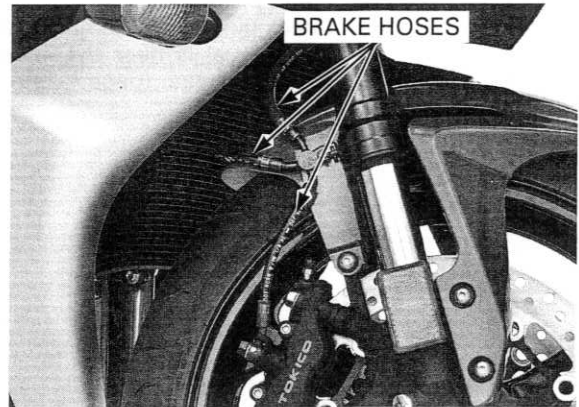

BRAKE LEVER ADJUSTMENT

Align the "Δ" mark on the brake lever with the index number on the adjuster.

The distance between the brake lever and the grip can be adjusted by turning the adjuster.

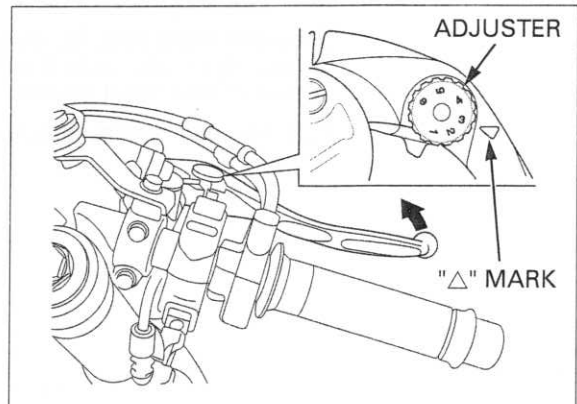

BRAKE PEDAL HEIGHT ADJUSTMENT

Loosen the lock nut and turn the push rod until the correct pedal height is obtained.

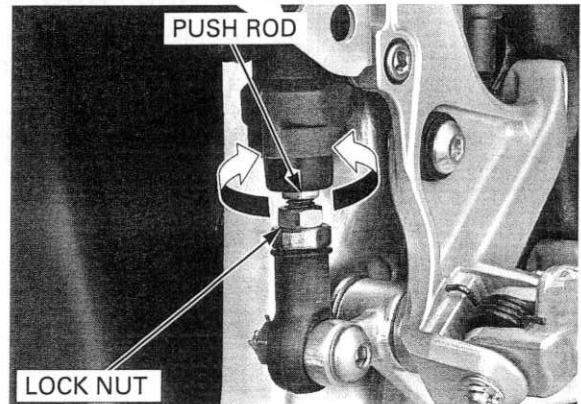

- When adjusting the push rod length, do not extend it more than 5.5 mm (0.22 in).

After adjustment, tighten the lock nut to the specified torque.

TORQUE: 18 N·m (1.8 kgf·m, 13 lbf·ft)

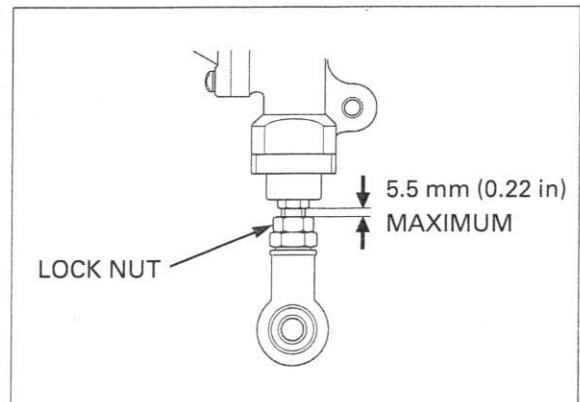

BRAKE LIGHT SWITCH

The front brake light switch does not require adjustment.

Adjust the brake light switch so that the brake light comes on just prior to the brake actually being engaged.

If the light fails to come on, adjust the switch so that the light comes on at the proper time. Hold the switch body and turn the adjuster. Do not turn the switch body.

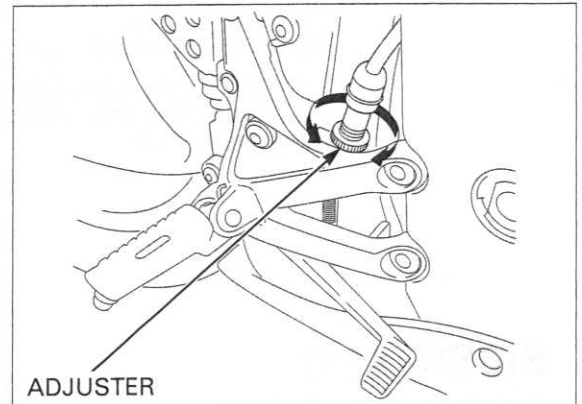

HEADLIGHT AIM

Place the motorcycle on a level surface.

Adjust the headlight aim as specified by local laws and regulations.

Adjust the headlight aim vertically by turning the vertical beam adjusting screw.

A clockwise rotation moves the beam up and counterclockwise rotation moves the beam down.

Adjust the headlight aim horizontally by turning the horizontal beam adjusting screw.

Left Headlight:

A clockwise rotation moves the beam toward the right and counterclockwise rotation moves the beam toward the left side of the rider.

Right Headlight:

A clockwise rotation moves the beam toward the left and counterclockwise rotation moves the beam toward the right side of the rider.

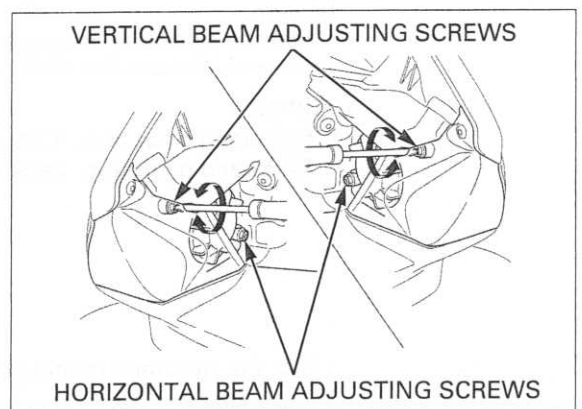

CLUTCH SYSTEM

Measure the clutch lever freeplay at the end of the clutch lever.

FREEPLAY: 10 – 20 mm (3/8 – 13/16 in)

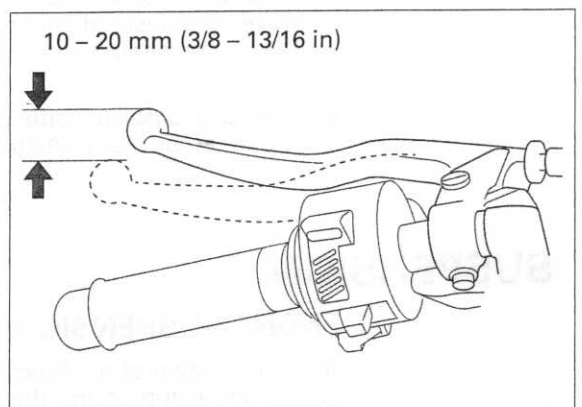

The adjuster may be damaged if it is positioned too far out, leaving minimal thread engagement.

Minor adjustment is made with the upper adjuster at the clutch lever.

Loosen the lock nut and turn the adjuster.

If the adjuster is threaded out near its limit and the correct freeplay cannot be obtained, turn the adjuster all the way in and back out one turn.

Tighten the lock nut while holding the adjuster and make a major adjustment as described as follows:

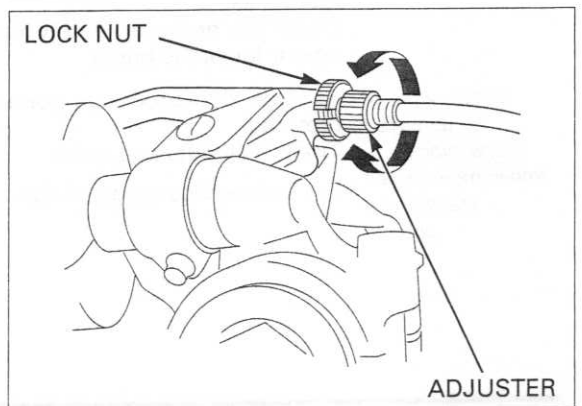

MAINTENANCE

Major adjustment is performed at the clutch lifter lever.

Loosen the lock nut and turn the adjusting nut to adjust the freeplay.

Tighten the lock nut while holding the adjusting nut.

If proper freeplay cannot be obtained, or the clutch slips during test ride, disassemble and inspect the clutch (page 10-7).

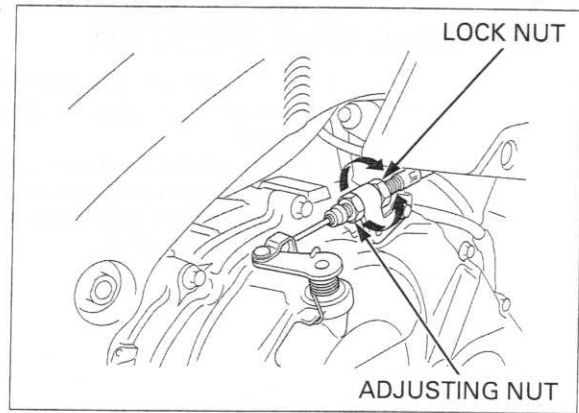

SIDESTAND

Support the motorcycle on a level ground.

Check the sidestand spring for damage or loss of tension.

Check the sidestand assembly for freedom of movement and lubricate the sidestand pivot if necessary.

TORQUE:

Sidestand pivot bolt: 10 N·m (1.0 kgf·m, 7 lbf·ft)

Sidestand pivot nut: 29 N·m (3.0 kgf·m, 21 lbf·ft)

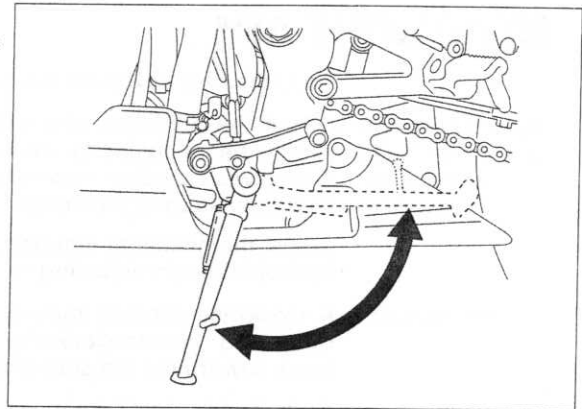

Check the sidestand ignition cut-off system:

- Sit astride the motorcycle and raise the sidestand.
- Start the engine with the transmission into neutral, then shift the transmission into gear, with the clutch lever squeezed.
- Move the sidestand full down.
- The engine should stop as the sidestand is lowered.

If there is a problem with the system, check the sidestand switch (page 20-20).

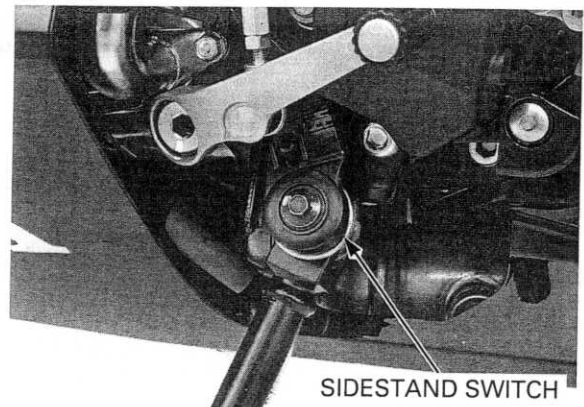

SUSPENSION

FRONT SUSPENSION INSPECTION

Check the action of the forks by operating the front brakes and compressing the front suspension several times.

Check the entire assembly for signs of leaks, damage or loose fasteners.

Loose, worn or damaged suspension parts impair motorcycles stability and control.

Replace damaged components which cannot be repaired.

Tighten all nuts and bolts.

For fork service (page 14-22).



FRONT SUSPENSION ADJUSTMENT

SPRING PRE-LOAD ADJUSTER

Spring pre-load can be adjusted by turning the adjuster.

TURN CLOCKWISE:

Increase the spring pre-load

TURN COUNTERCLOCKWISE:

Decrease the spring pre-load

PRE-LOAD ADJUSTER ADJUSTABLE RANGE:

15 turns

PRE-LOAD ADJUSTER STANDARD POSITION:

5 turns clockwise from minimum

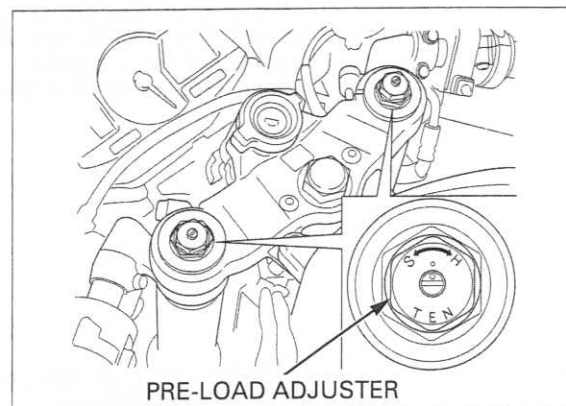

COMPRESSION AND REBOUND DAMPING ADJUSTERS

NOTICE

Do not turn the adjusters more than the given positions or the adjusters may be damaged.

- All damping adjustments are referenced from the full hard position.

To adjust both sides equally, set the right and left damping adjusters to the same position.

The compression and rebound damping can be adjusted by turning the adjusters.

DIRECTION H: Increase the damping force

DIRECTION S: Decrease the damping force

Turn the compression adjuster clockwise until it stops (full hard position), then turn the adjuster counterclockwise.

COMPRESSION ADJUSTER STANDARD POSITION:

2 turns out from full hard

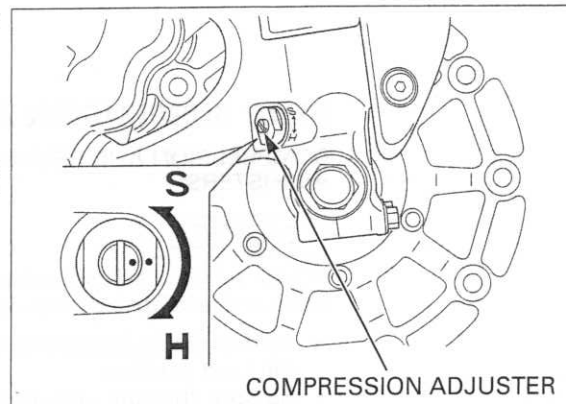

Turn the rebound adjuster clockwise until it stops (full hard position), then turn the adjuster counterclockwise.

REBOUND ADJUSTER STANDARD POSITION:

2-1/2 turns out from full hard

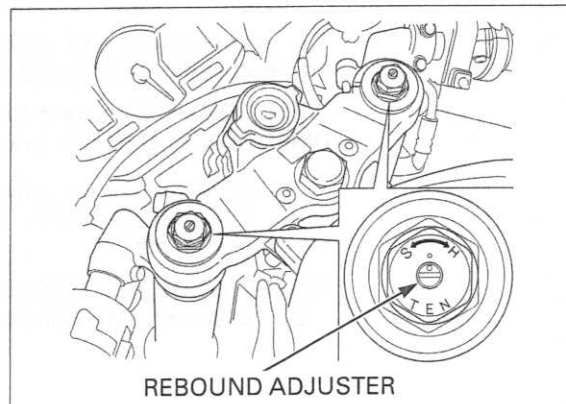

MAINTENANCE

REAR SUSPENSION INSPECTION

Support the motorcycle securely and raise the rear wheel off the ground.

Check for worn swingarm bearings by grabbing the rear end of the swingarm and attempting to move the swingarm side to side.

Replace the bearings if any looseness is noted.

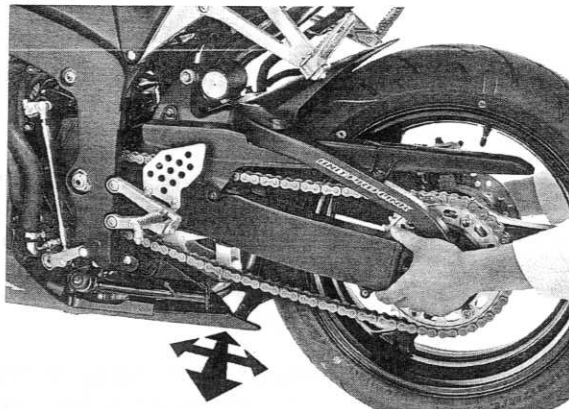

Check the action of the shock absorber by compressing it several times.

Check the entire shock absorber assembly for signs of leaks, damage or loose fasteners.

Replace damaged components which cannot be repaired.

Tighten all nuts and bolts.

For shock absorber service (page 15-14).



REAR SUSPENSION ADJUSTMENT

COMPRESSION AND REBOUND DAMPING ADJUSTERS

NOTICE

Do not turn the adjusters more than the given positions or the adjusters may be damaged.

- All damping adjustments are referenced from the full hard position.
- Be sure that the compression adjuster is firmly located in a detent and not between positions.

The compression and rebound damping can be adjusted by turning the adjusters.

DIRECTION H: Increase the damping force

DIRECTION S: Decrease the damping force

Turn the compression adjuster clockwise until it stops (full hard position), then turn the adjuster counterclockwise.

COMPRESSION ADJUSTER STANDARD POSITION:

22 clicks out from full hard

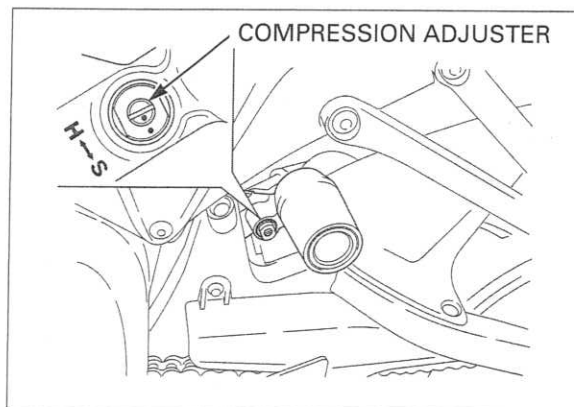

Turn the rebound adjuster clockwise until it stops (full hard position), then turn the adjuster counter-clockwise.

REBOUND ADJUSTER STANDARD POSITION:
2-1/2 turns out from full hard

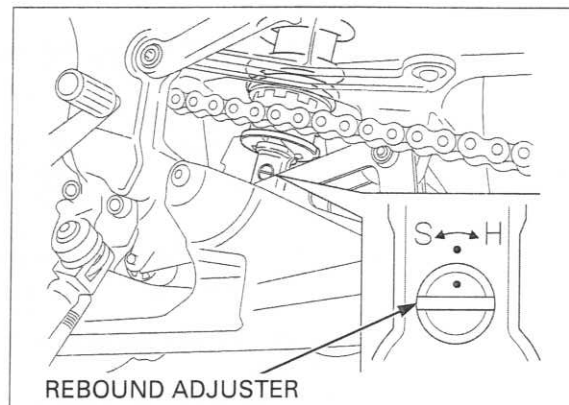

NUTS, BOLTS, FASTENERS

Check that all chassis nuts and bolts are tightened to their correct torque values (page 1-13).
Check that all safety clips, hose clamps and cable stays are in place and properly secured.

WHEELS/TIRES

Support the motorcycle securely and raise the front wheel off the ground.
Hold the front fork leg and move the front wheel sideways with force to see if the wheel bearings are worn.

For front wheel service (page 14-16).

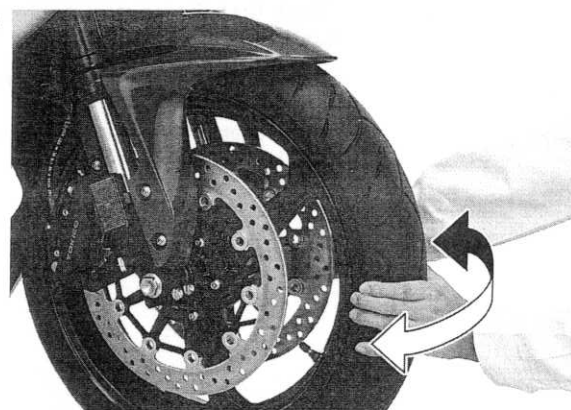

Support the motorcycle securely and raise the rear wheel off the ground.
Hold the swingarm and move the rear wheel sideways with force to see if the wheel bearings are worn.

For rear wheel service (page 15-7).

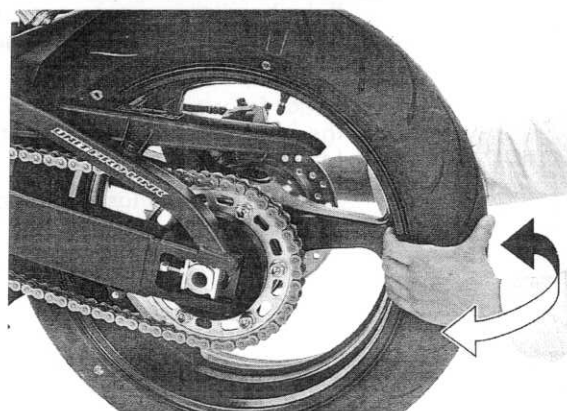

MAINTENANCE

Tire pressure should be checked when the tires are COLD.

RECOMMENDED TIRE PRESSURE AND TIRE SIZE:

		FRONT	REAR
Tire pressure kPa (kgf/cm ² , psi)		250 (2.50, 36)	290 (2.90, 42)
Tire size		120/70 ZR 17 M/C (58W)	180/55 ZR 17 M/C (73W)
Tire brand	Bridgestone	BT015F RADIAL E	BT015R RADIAL E
	Dunlop	Qualifier PTG	Qualifier PTG

Check the tires for cuts, embedded nails, or other damage.

Measure the tread depth at the center of the tires. Replace the tires when the tread depth reaches the following limits.

MINIMUM TIRE TREAD DEPTH:

FRONT: 1.5 mm (0.06 in)

REAR: 2.0 mm (0.08 in)

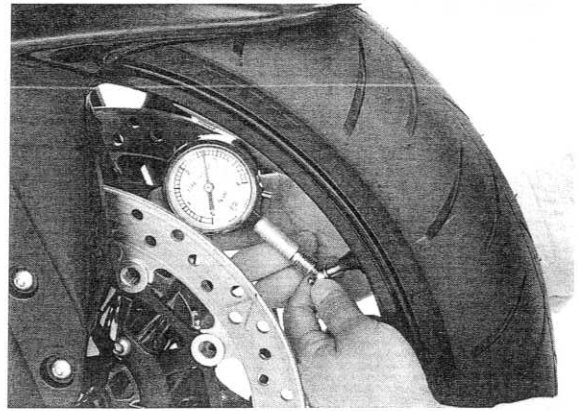

STEERING HEAD BEARINGS

Check that the control cables do not interfere with handlebar rotation.

Support the motorcycle securely and raise the front wheel off the ground.

Check that the handlebar moves freely from side to side.



If the handlebar moves unevenly, binds, or has vertical movement, inspect the steering head bearings (page 14-34).

Check for worn steering stem bearings by grabbing the front fork leg and attempting to move the front fork side to side.

Replace the bearings if any looseness is noted.

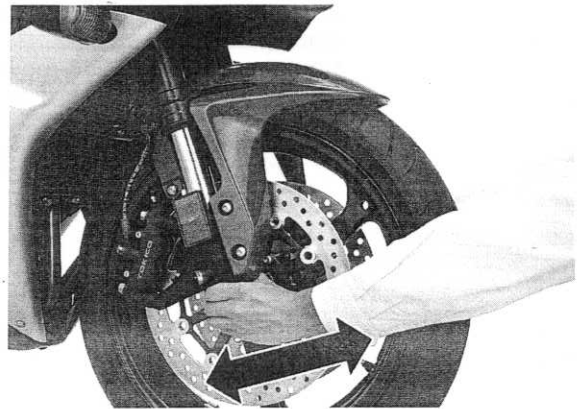

5. LUBRICATION SYSTEM

LUBRICATION SYSTEM DIAGRAM	5-2	OIL STRAINER/PRESSURE RELIEF VALVE	5-5
SERVICE INFORMATION	5-3	OIL PUMP	5-7
TROUBLESHOOTING	5-4	OIL COOLER	5-13
OIL PRESSURE INSPECTION	5-5		

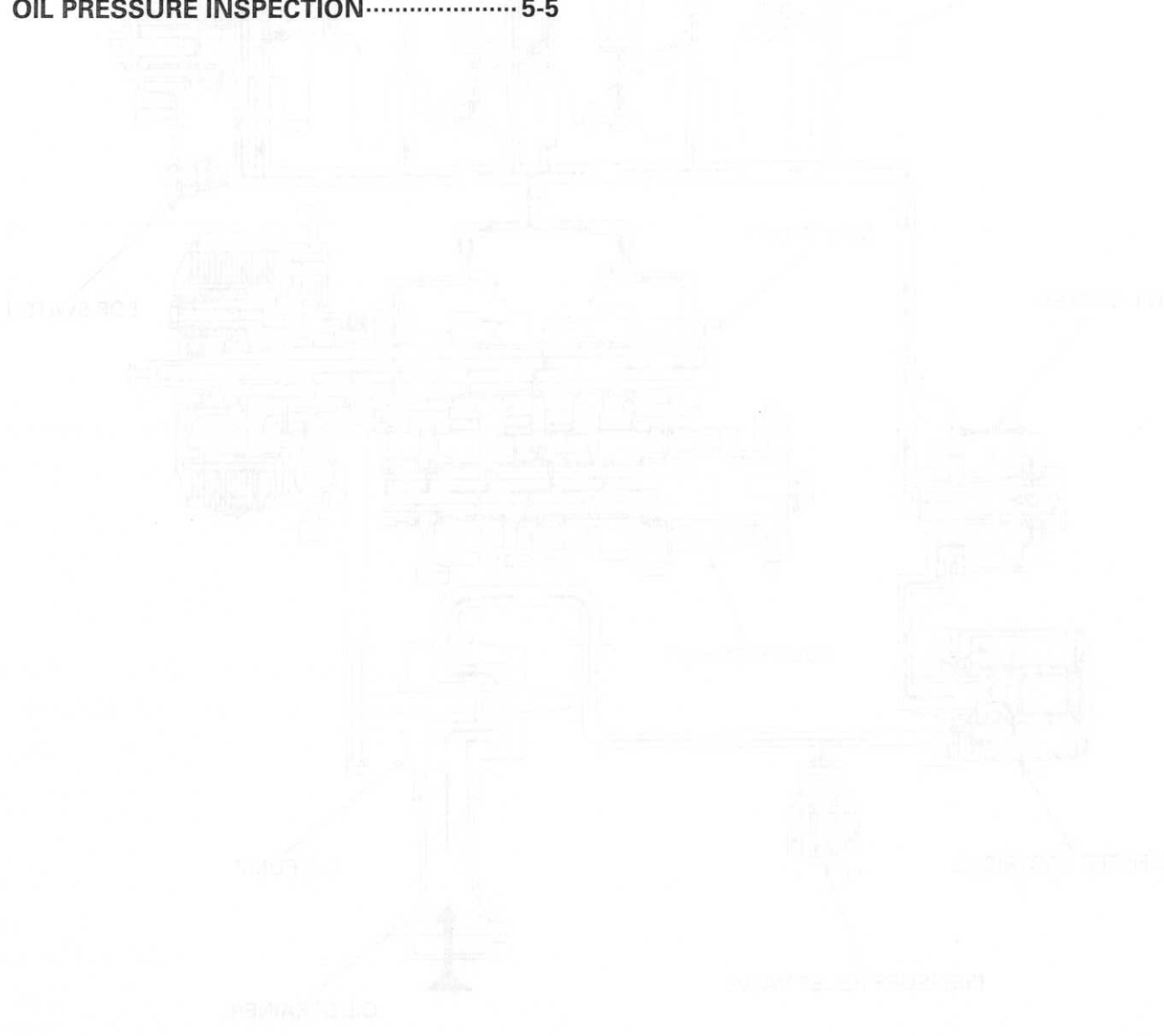

LUBRICATION SYSTEM

LUBRICATION SYSTEM DIAGRAM

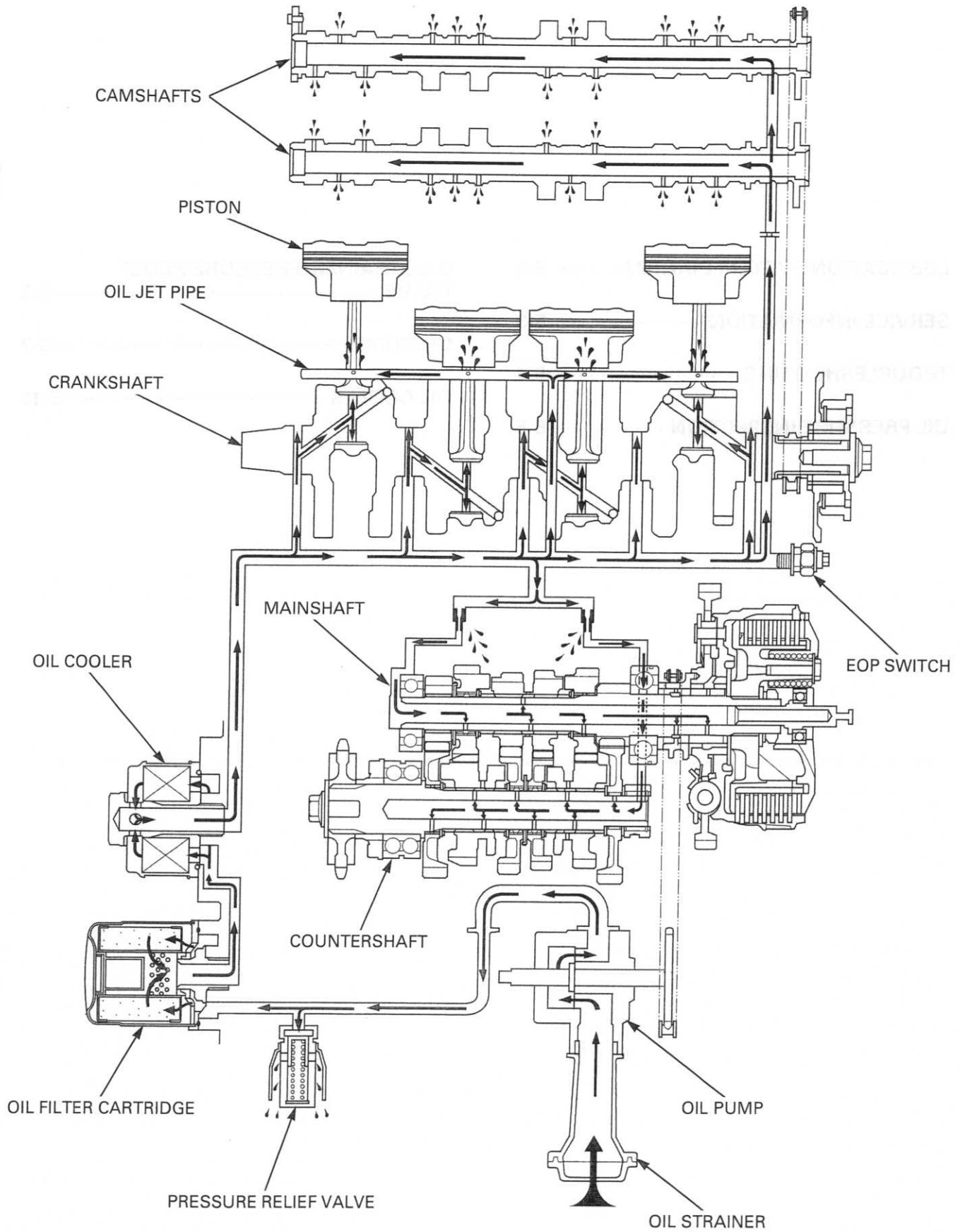

SERVICE INFORMATION

GENERAL

⚠ CAUTION

Used engine oil may cause skin cancer if repeatedly left in contact with the skin for prolonged periods. Although this is unlikely unless you handle used oil on a daily basis, it is still advisable to thoroughly wash your hands with soap and water as soon as possible after handling used oil.

- This section covers service of the oil pump and EOP switch.
- The oil pump can be serviced with the engine installed in the frame.
- The service procedures in this section must be performed with the engine oil drained.
- When removing and installing the oil pump, use care not to allow dust or dirt to enter the engine.
- If any portion of the oil pump is worn beyond the specified service limits, replace the oil pump as an assembly.
- After the oil pump has been installed, check that there are no oil leaks and that oil pressure is correct.

SPECIFICATIONS

Unit: mm (in)

ITEM		STANDARD	SERVICE LIMIT
Engine oil capacity	After draining	2.7 liter (2.9 US qt, 2.4 Imp qt)	-
	After oil filter change	2.8 liter (3.0 US qt, 2.5 Imp qt)	-
	After disassembly	3.5 liter (3.7 US qt, 3.1 Imp qt)	-
Recommended engine oil		Pro Honda GN4 4-stroke oil (U.S.A. and Canada) or equivalent motor oil API service classification: SG or Higher JASO T 903 standard: MA Viscosity: SAE 10W-30	-
Oil pressure at EOP switch		505 kPa (5.1 kgf/cm ² , 73 psi) at 6,000 rpm/(80°C/176°F)	-
Oil pump	Tip clearance	0.15 (0.006)	0.20 (0.008)
	Body clearance	0.15 – 0.21 (0.006 – 0.008)	0.35 (0.014)
	Side clearance	0.04 – 0.09 (0.002 – 0.004)	0.17 (0.007)

TORQUE VALUES

EOP switch	12 N·m (1.2 kgf·m, 9 lbf·ft)	Apply sealant to the threads
EOP switch wire terminal bolt	2.0 N·m (0.2 kgf·m, 1.5 lbf·ft)	
Oil pump assembly bolt	12 N·m (1.2 kgf·m, 9 lbf·ft)	CT bolt
Oil pump driven sprocket bolt	15 N·m (1.5 kgf·m, 11 lbf·ft)	Apply locking agent to the threads
Oil cooler bolt	59 N·m (6.0 kgf·m, 44 lbf·ft)	Apply oil to the threads
Oil pipe A mounting bolt	12 N·m (1.2 kgf·m, 9 lbf·ft)	Apply locking agent to the threads

LUBRICATION SYSTEM

TOOLS

Oil pressure gauge set
07506-300001

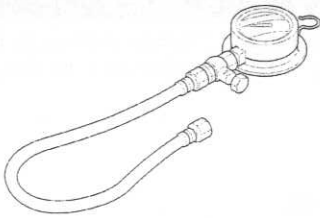

or equivalent commercially available in U.S.A. (MT37A)

Oil pressure gauge attachment
07406-0030000

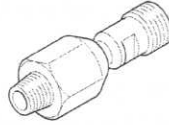

or equivalent commercially available in U.S.A. (AT77AH)

TROUBLESHOOTING

Oil level too low

- Oil consumption
- External oil leak
- Worn piston rings
- Improperly installed piston rings
- Worn cylinders
- Worn valve stem seals
- Worn valve guide

Low oil pressure

- Oil level low
- Clogged oil strainer
- Internal oil leak
- Incorrect oil being used

No oil pressure

- Oil level too low
- Oil pressure relief valve stuck open
- Broken oil pump drive chain
- Broken oil pump drive or driven sprocket
- Damaged oil pump
- Internal oil leak

High oil pressure

- Oil pressure relief valve stuck closed
- Clogged oil filter, oil cooler gallery or metering orifice
- Incorrect oil being used

Oil contamination

- Oil or filter not changed often enough
- Worn piston rings

Oil emulsification

- Blown cylinder head gasket
- Leaky coolant passage
- Entry of water

OIL PRESSURE INSPECTION

Remove the EOP switch (page 20-15).
Install the oil pressure gauge attachment to the switch base.
Connect the oil pressure gauge to the oil pressure gauge attachment.

TOOLS:

Oil pressure gauge set

07506-3000001 or equivalent commercially available in U.S.A. (MT37A)

Oil pressure gauge attachment

07406-0030000 or equivalent commercially available in U.S.A. (AT77AH)

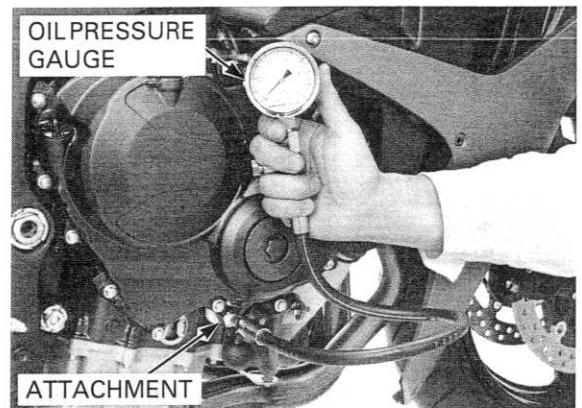

Check the engine oil level (page 4-17).

Warm the engine to normal operating temperature (approximately 80°C/176°F) and increase the engine speed to 6,000 rpm and read the oil pressure.

Standard:

505 kPa (5.1 kgf/cm², 73 psi) at 6,000 rpm (80°C/176°F)

Stop the engine and remove the tools.

Install the EOP switch (page 20-15).

OIL STRAINER/PRESSURE RELIEF VALVE

REMOVAL

Drain the engine oil (page 4-17).
Remove the following:

- Exhaust pipe (page 3-24)
- Radiator reserve tank (page 7-20)

Remove the bolts, stay and oil pan.

Loosen the bolts in a crisscross pattern in two or three steps.

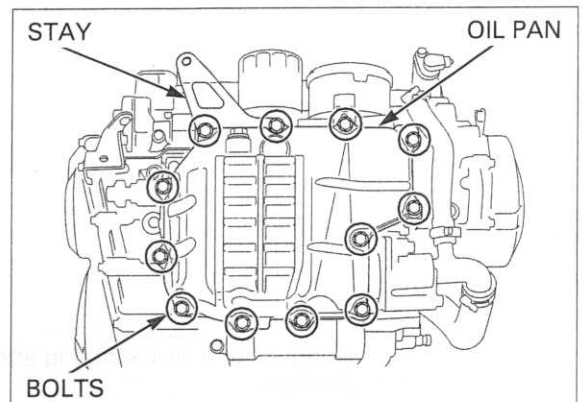

Remove the oil strainer and seal ring.

Clean the oil strainer screen and check for damage, replace it if necessary.

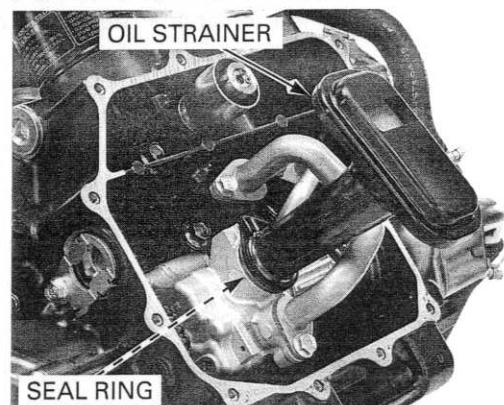

LUBRICATION SYSTEM

Remove the pressure relief valve and O-ring.

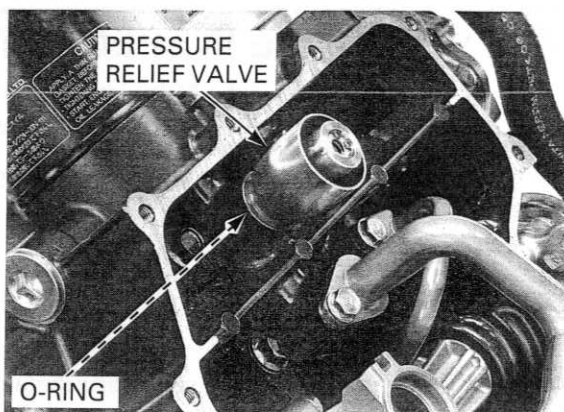

INSPECTION

Check the operation of the pressure relief valve by pushing on the piston.
Disassemble the relief valve by removing the snap ring.

Inspect the piston for wear, unsmooth movement or damage.

Inspect the spring for fatigue or damage.

Assemble the pressure relief valve in the reverse order of disassembly.

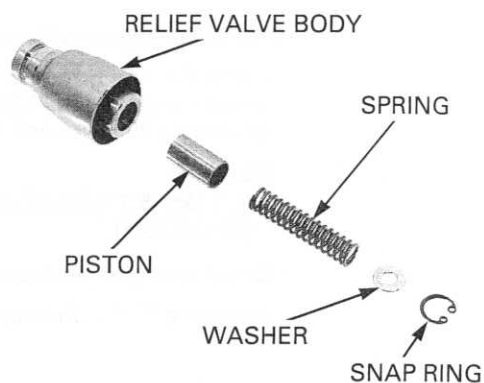

INSTALLATION

Apply oil to a new O-ring and install it onto the pressure relief valve.

Install the pressure relief valve to the crankcase.

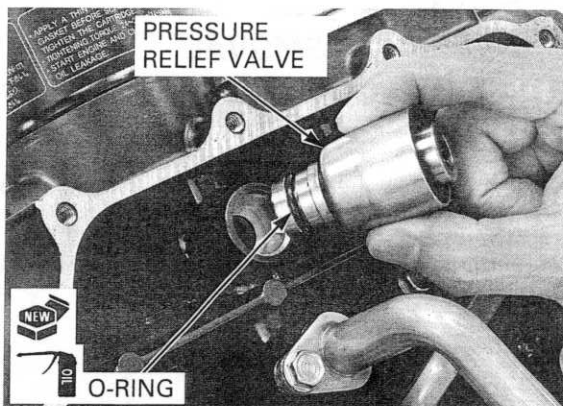

Apply oil to a new seal ring and install it onto the oil strainer.

Install the oil strainer to the crankcase while aligning the oil strainer boss with the groove of the oil pump.

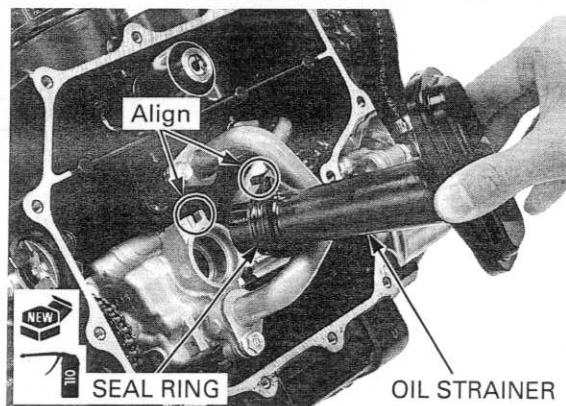

Clean the oil pan mating surface thoroughly.

Do not apply more sealant than necessary.

Apply sealant (Three Bond 1207B or an equivalent) to the mating surface.

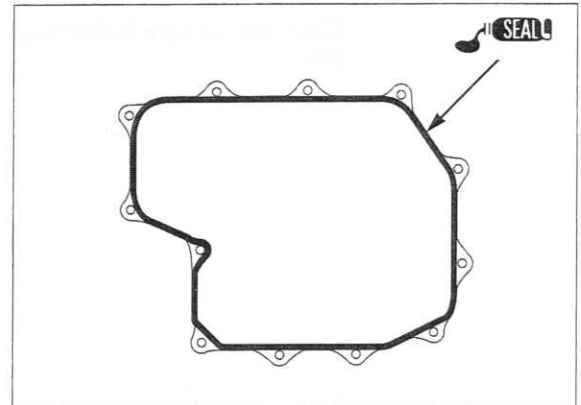

Install the oil pan, stay and bolts.

Tighten the bolts in a crisscross pattern in two or three steps.

Install the following:

- Radiator reserve tank (page 7-20)
- Exhaust pipe (page 3-26)

Fill the crankcase with the recommended oil (page 4-17).

After installation, start the engine and check that there are no oil leaks.

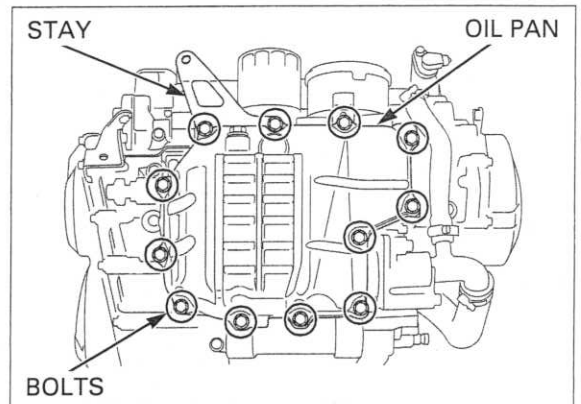

OIL PUMP

REMOVAL

Drain the engine oil (page 4-17).

Remove the following:

- Right crankcase cover (page 10-5)
- Oil strainer (page 5-5)

Remove the water pump (page 7-17), if you remove the oil pipe B.

Remove the bolt, washer and oil pump driven sprocket.

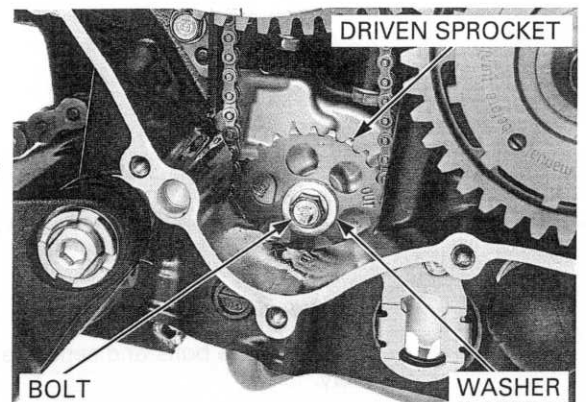

Remove the bolts, oil pipe A and seal rings.

Clean the oil pipe A thoroughly and check for damage.

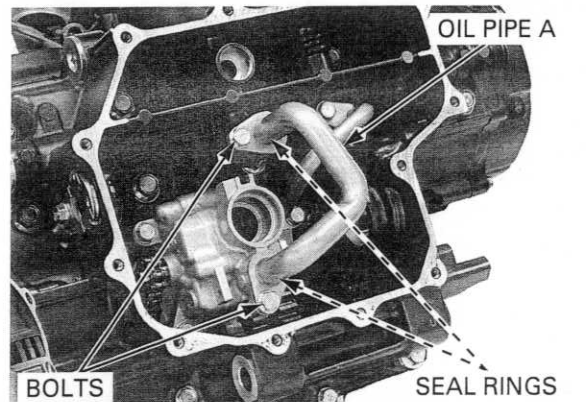

LUBRICATION SYSTEM

Remove the bolts, oil pipe B and O-rings.

Clean the oil pipe B thoroughly and check for damage.

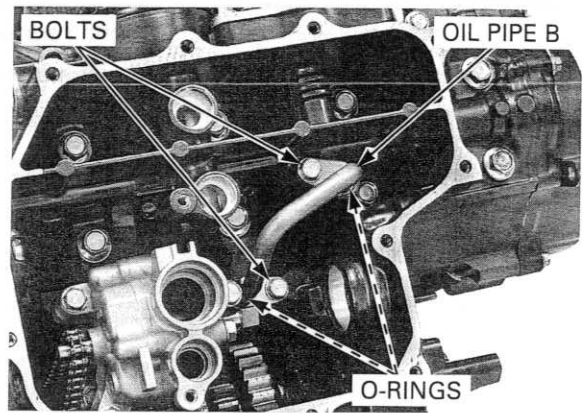

Remove the bolts and oil pump assembly.

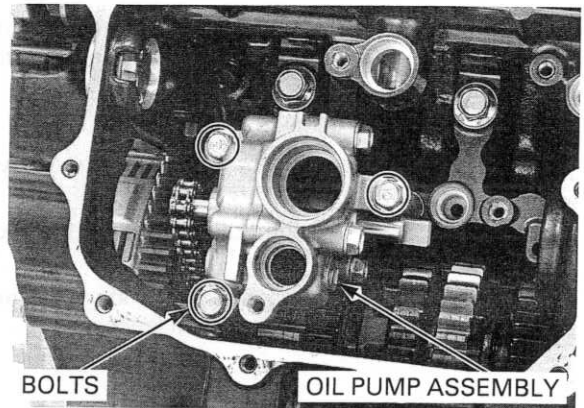

Remove the dowel pins.

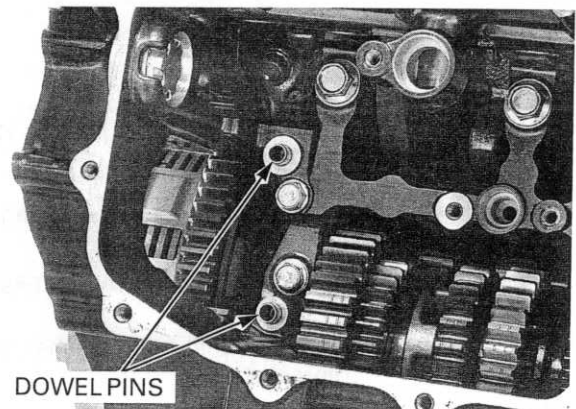

DISASSEMBLY

Remove the bolts and separate the oil pump assembly.

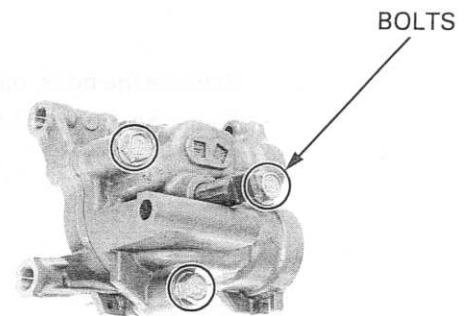

Remove the dowel pins.

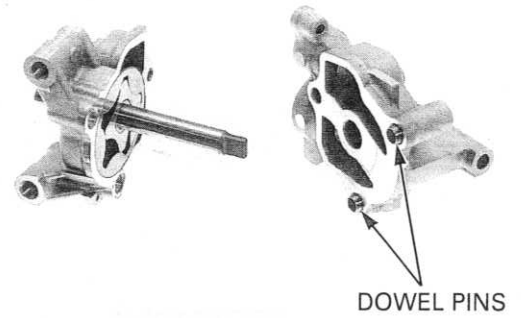

Remove the thrust washer, drive pin, oil pump shaft, outer rotor and inner rotor from the oil pump body.

Clean all disassembled parts thoroughly.

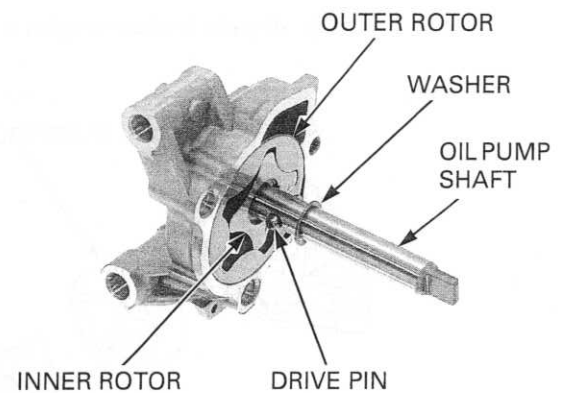

INSPECTION

- If any portion of the oil pump is worn beyond the service limit, replace the oil pump as an assembly.

Temporarily install the outer and inner rotors into the oil pump body.

Temporarily install the drive pin and oil pump shaft.

Measure the rotor tip clearance.

SERVICE LIMIT: 0.20 mm (0.008 in)

TIP CLEARANCE:

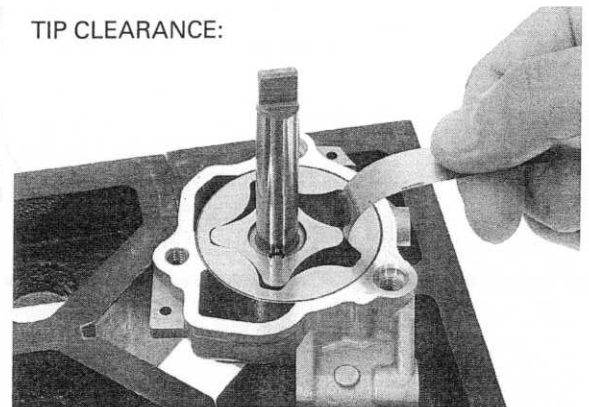

Measure the pump body clearance.

SERVICE LIMIT: 0.35 mm (0.014 in)

BODY CLEARANCE:

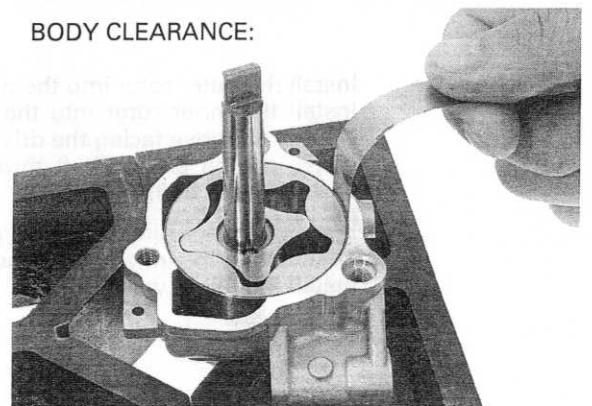

LUBRICATION SYSTEM

Measure the side clearance using a straight edge and feeler gauge.

SIDE CLEARANCE:

SERVICE LIMIT: 0.17 mm (0.007 in)

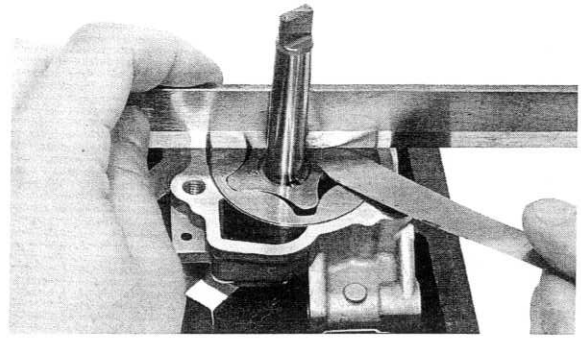

ASSEMBLY

Dip all parts in clean engine oil.

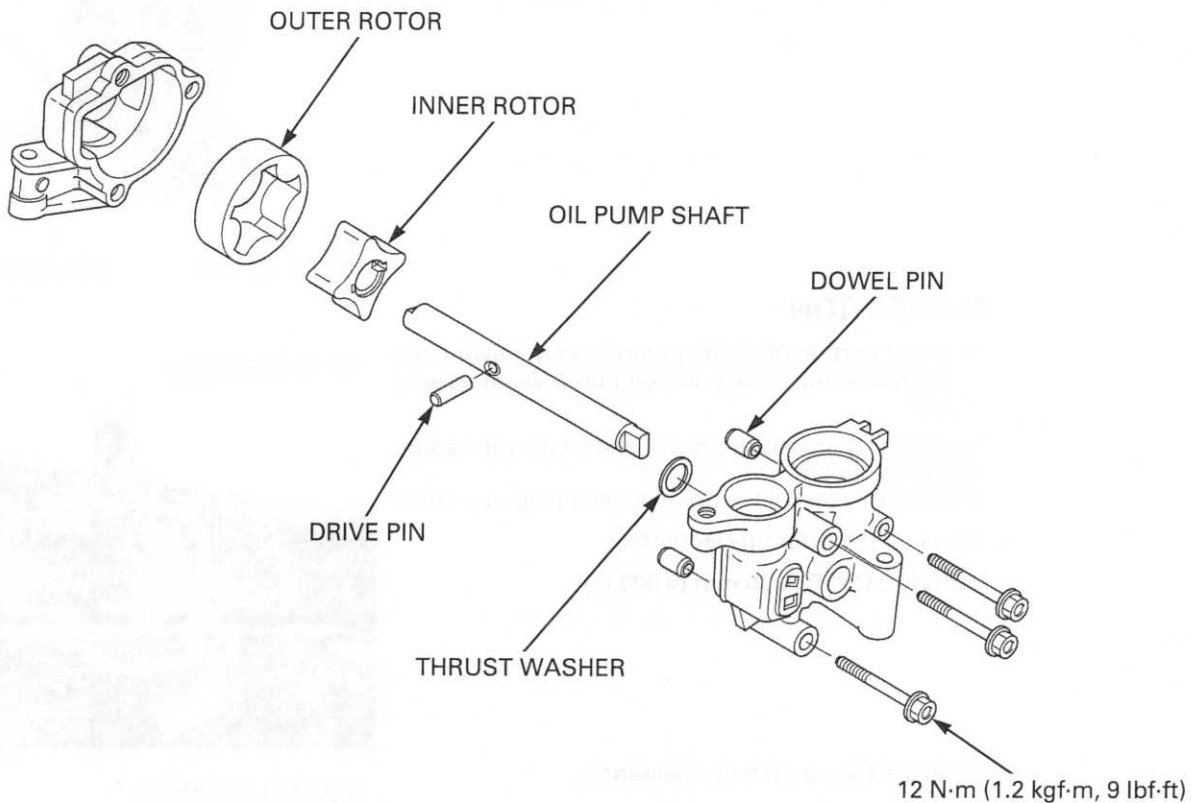

Install the outer rotor into the oil pump body.
Install the inner rotor into the outer rotor with its drive pin groove facing the drive pin.
Install the oil pump shaft through the inner rotor and oil pump body.

Install the drive pin into the oil pump shaft hole and align it with the inner rotor groove.
Install the thrust washer.

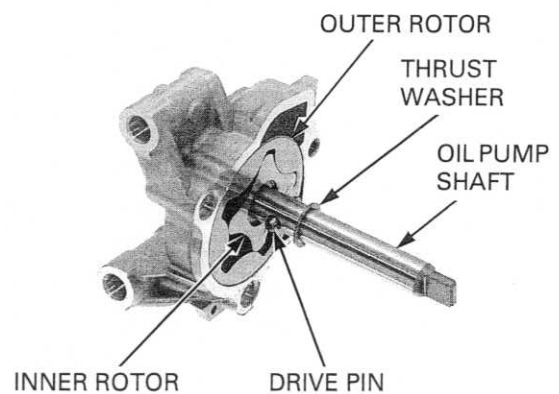

Install the dowel pins.

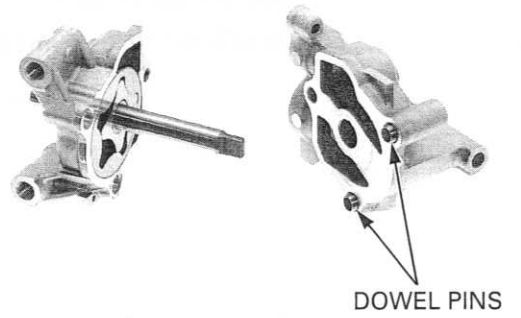

Assemble the oil pump and tighten the bolts to the specified torque.

TORQUE: 12 N·m (1.2 kgf·m, 9 lbf·ft)

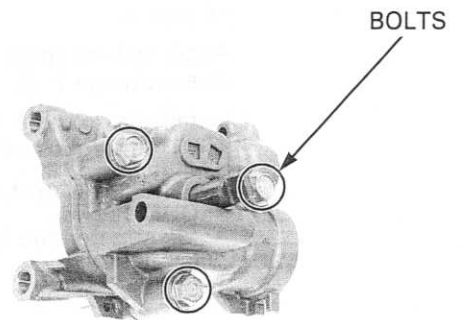

INSTALLATION

Install the dowel pins to the crankcase.

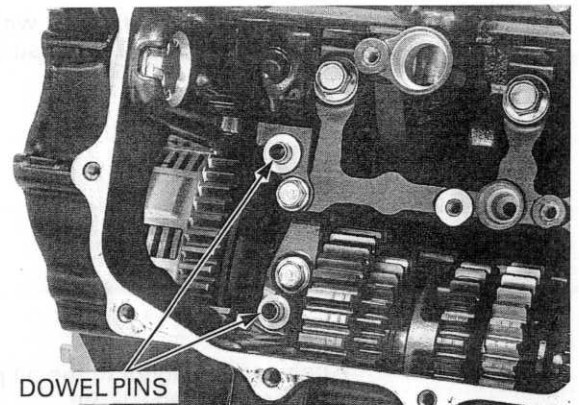

Install the oil pump assembly and tighten the bolts securely.

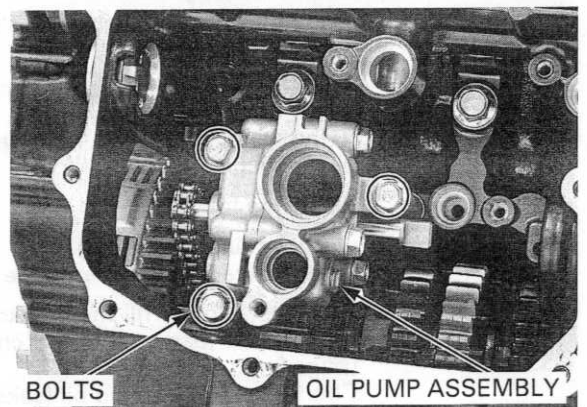

LUBRICATION SYSTEM

Apply oil to new O-rings and install them onto the oil pipe B.

Apply locking agent to the oil pipe B mounting bolt threads (page 1-19).

Install the oil pipe B and tighten the bolts securely.

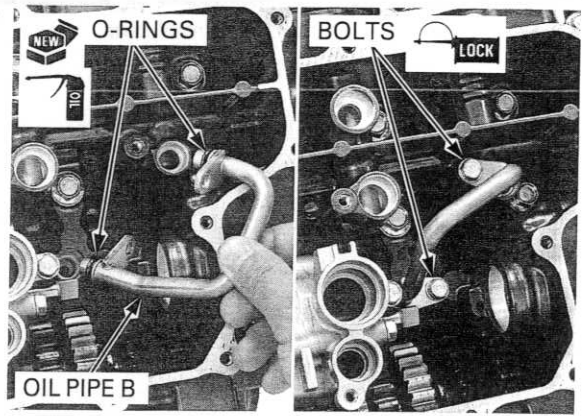

Apply oil to new seal rings and install them onto the oil pipe A.

Apply locking agent to the oil pipe A mounting bolt threads (page 1-19).

Install the oil pipe A and tighten the bolts to the specified torque in the order as shown.

TORQUE: 12 N·m (1.2 kgf·m, 9 lbf·ft)

- First tighten the No. 1 bolt, then tighten the No. 2 bolt.

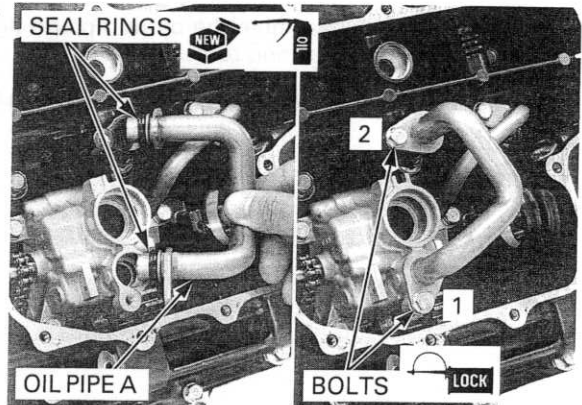

Apply oil to the oil pump driven sprocket and drive chain.

Install the driven sprocket with its "OUT" mark facing out by aligning the flat surfaces.

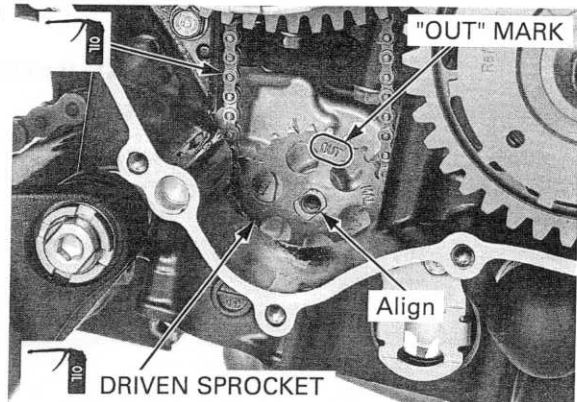

Apply locking agent to the oil pump driven sprocket bolt threads (page 1-19).

Tighten the driven sprocket bolt/washer to the specified torque.

TORQUE: 15 N·m (1.5 kgf·m, 11 lbf·ft)

If the oil pipe B was removed, install the water pump (page 7-18).

Install the following:

- Oil strainer (page 5-6)
- Right crankcase cover (page 10-26)

After installation, fill the crankcase with the recommended oil (page 4-17) and check the oil pressure (page 5-5).

Check that there are no oil leaks.

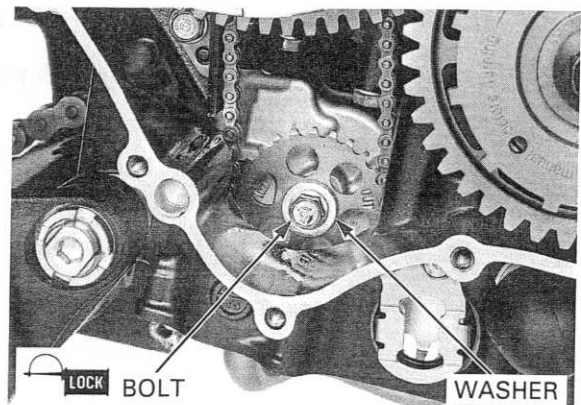

OIL COOLER

REMOVAL

Drain the engine oil (page 4-17).
Drain the coolant from the system (page 7-7).

Loosen the hose clamp screws and disconnect the water hoses from the oil cooler.

Remove the bolt, sealing washer and oil cooler.
Remove the O-ring from the oil cooler.

INSPECTION

Check the oil cooler for damage.

INSTALLATION

Apply oil to a new O-ring and install it into the oil cooler groove.

Apply oil to the oil cooler bolt threads and a new sealing washer seating surface.

Install the oil cooler to the crankcase by aligning the oil cooler groove with the crankcase boss.

Install the sealing washer and oil cooler bolt.

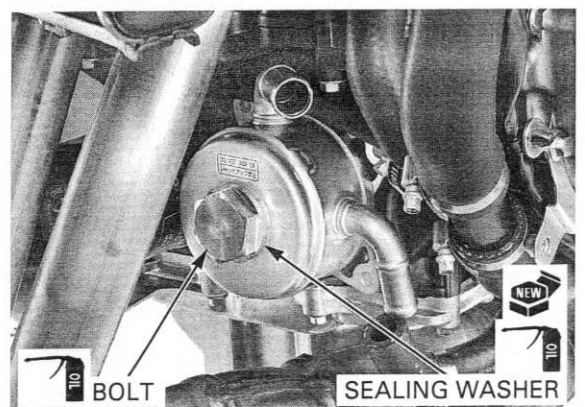
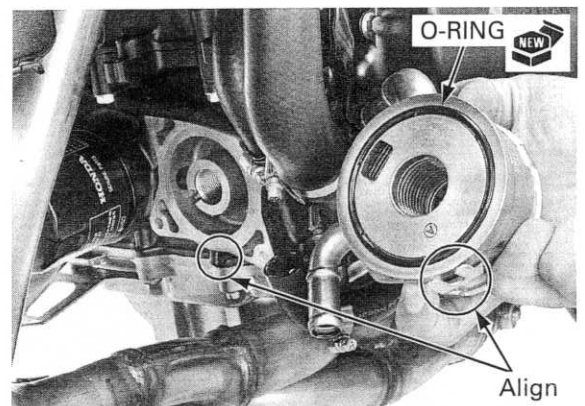
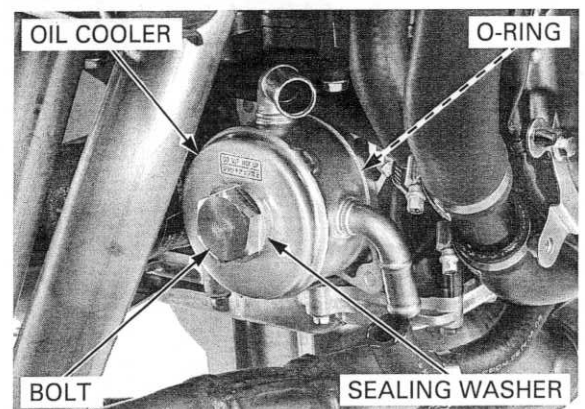
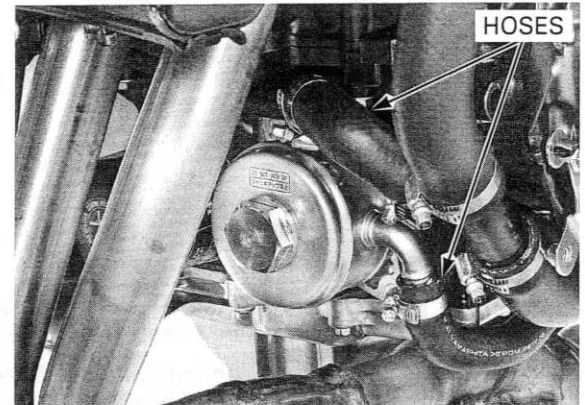

LUBRICATION SYSTEM

Hold the oil cooler by your hand and tighten the bolt to the specified torque.

TORQUE: 59 N·m (6.0 kgf·m, 44 lbf·ft)

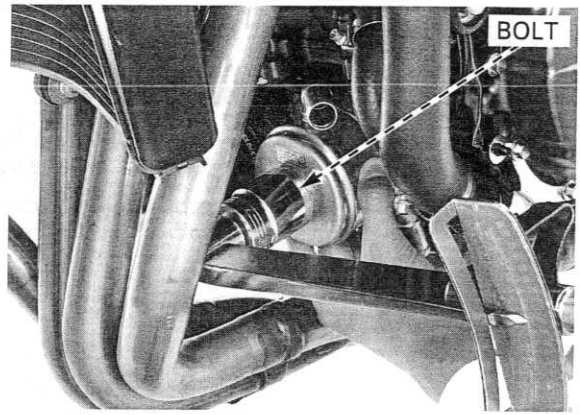

Connect the water hoses and tighten the hose clamp screws securely (page 7-19).

Fill the cooling system and bleed any air (page 7-7).
Fill the crankcase with the recommended oil (page 4-17) and check that there are no oil leaks.

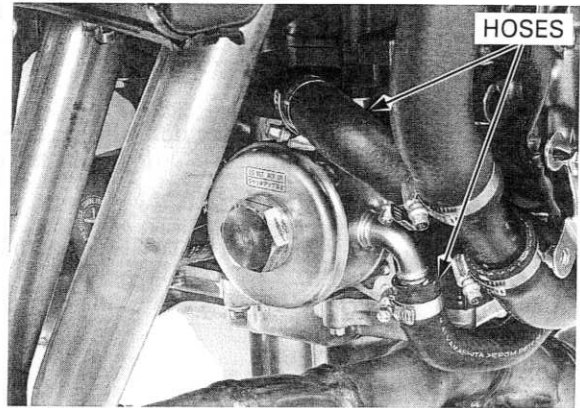

6. FUEL SYSTEM (PGM-FI)

COMPONENT LOCATION	6-2	THROTTLE BODY	6-60
SERVICE INFORMATION	6-3	PRIMARY INJECTOR.....	6-65
PGM-FI SYMPTOM TROUBLESHOOTING	6-7	ENGINE IDLE SPEED.....	6-67
PGM-FI SYSTEM LOCATION	6-8	IACV	6-68
PGM-FI SYSTEM DIAGRAM	6-9	KNOCK SENSOR	6-69
CONNECTOR LOCATION	6-10	MAP SENSOR.....	6-70
PGM-FI TROUBLESHOOTING INFORMATION	6-13	IAT SENSOR	6-71
DTC INDEX.....	6-16	ECT SENSOR	6-71
DTC TROUBLESHOOTING.....	6-18	CMP SENSOR.....	6-71
MIL CIRCUIT TROUBLESHOOTING	6-42	BANK ANGLE SENSOR	6-72
FUEL LINE INSPECTION	6-42	ENGINE STOP RELAY	6-74
FUEL PUMP UNIT.....	6-47	ECM.....	6-74
FUEL PUMP RELAY	6-49	SECONDARY AIR SUPPLY SYSTEM	6-77
FUEL TANK	6-50	EVAP PURGE CONTROL SOLENOID VALVE/ CANISTER (CALIFORNIA TYPE).....	6-79
AIR CLEANER HOUSING	6-52	EGCV SERVOMOTOR.....	6-80
SECONDARY INJECTOR.....	6-56	EGCV	6-83

COMPONENT LOCATION

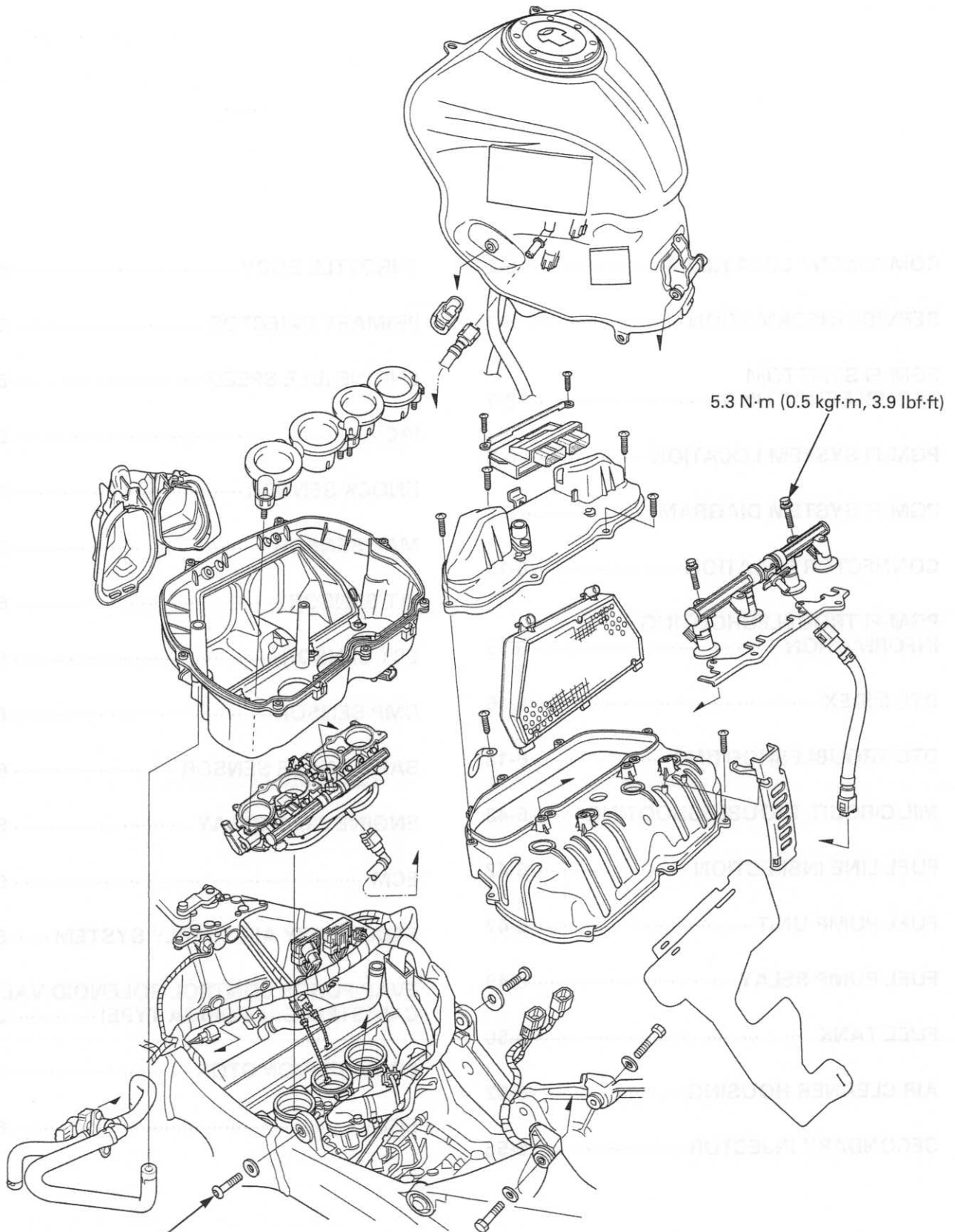

30 N·m (3.1 kgf·m, 22 lbf·ft)

SERVICE INFORMATION

GENERAL

- Be sure to relieve the fuel pressure while the engine is OFF.
- Bending or twisting the control cables will impair smooth operation and could cause the cables to stick or bind, resulting in loss of vehicle control.
- Work in a well ventilated area. Smoking or allowing flames or sparks in the work area or where gasoline is stored can cause a fire or explosion.
- Do not snap the throttle valve from full open to full close after the throttle cable has been removed. It may cause incorrect idle operation.
- Seal the cylinder head intake ports with tape or a clean cloth to keep dirt and debris from entering the intake ports after the throttle body has been removed.
- Do not apply excessive force to the fuel rail on the throttle body while removing or installing the throttle body.
- Do not damage the throttle body. It may cause incorrect throttle and idle valve synchronization.
- Prevent dirt and debris from entering the engine, clean the throttle bore and fuel hose with compressed air.
- The throttle body is factory pre-set. Do not disassemble in a way other than shown in this manual.
- Do not push the fuel pump base under the fuel tank when the fuel tank is stored.
- Always replace the packing when the fuel pump is removed.
- The PGM-FI system is equipped with the Self-Diagnostic System described. If the malfunction indicator lamp (MIL) blinks, follow the Self-Diagnostic Procedures to remedy the problem.
- When checking the PGM-FI, always follow the steps in the troubleshooting flow chart (page 6-18).
- The PGM-FI system is provided with a fail-safe function to secure a minimum running capability even when there is any trouble in the system. When any abnormality is detected by the self-diagnosis function, running capability is secured by using numerical values preset in advance in the program map. It must be remembered, however, that when any abnormality is detected in 8 injectors and/or the CKP and CMP sensor, the fail safe function stops the engine to protect it from damage.
- For PGM-FI system location (page 6-8).
- A faulty PGM-FI system is often related to poorly connected or corroded connectors. Check those connections before proceeding.
- For fuel level sensor inspection (page 20-16).
- When disassembling the PGM-FI parts, note the location of the O-rings. Replace them with new ones upon reassembly.
- Before disconnecting the fuel hose, relieve fuel pressure from the system by disconnecting the quick connect fitting (page 6-42).
- Use a digital tester for PGM-FI system inspection.
- Do not loosen or tighten the white painted bolts and screws of the throttle body. Loosening or tightening them can cause throttle valve and idle control failure.

FUEL SYSTEM (PGM-FI)

SPECIFICATIONS



ITEM		SPECIFICATIONS
Throttle body identification number	Except California type	GQ64C
	California type	GQ64B
Idle speed		1,400 ± 100 rpm
Throttle grip freeplay		2 – 4 mm (1/16 – 3/16 in)
IAT sensor resistance (at 20°C/68°F)		1 – 4 kΩ
ECT sensor resistance (at 20°C/68°F)		2.3 – 2.6 kΩ
Fuel injector resistance (at 20°C /68°F)	Primary injector	11 – 13 Ω
	Secondary injector	11 – 13 Ω
PAIR control solenoid valve resistance (at 20°C/68°F)		23 – 27 Ω
CMP sensor peak voltage (at 20°C/68°F)		0.7 V minimum
CKP sensor peak voltage (at 20°C/68°F)		0.7 V minimum
Fuel pressure at idle		343 kPa (3.5 kgf/cm ² , 50 psi)
Fuel pump flow (at 12V)		167 cm ³ (5.6 US oz, 5.9 Imp oz) minimum/10 seconds

TORQUE VALUES

ECT sensor	23 N·m (2.3 kgf·m, 17 lbf·ft)
Primary fuel rail mounting bolt	5.1 N·m (0.5 kgf·m, 3.8 lbf·ft)
Secondary fuel rail mounting bolt	5.3 N·m (0.5 kgf·m, 3.9 lbf·ft)
Fuel tank mounting bolt	30 N·m (3.1 kgf·m, 22 lbf·ft)
Fuel pump mounting nut	12 N·m (1.2 kgf·m, 9 lbf·ft)
Air funnel/lower housing mounting screw	4.2 N·m (0.4 kgf·m, 3.1 lbf·ft)
Bank angle sensor mounting screw	1.5 N·m (0.2 kgf·m, 1.1 lbf·ft)
IACV setting plate torx screw	2.1 N·m (0.2 kgf·m, 1.5 lbf·ft)
EGCV pulley nut	5.0 N·m (0.5 kgf·m, 3.7 lbf·ft)
Knock sensor mounting bolt	22 N·m (2.2 kgf·m, 16 lbf·ft)
IAT sensor mounting screw	1.1 N·m (0.1 kgf·m, 0.8 lbf·ft)
MAP sensor mounting screw	1.1 N·m (0.1 kgf·m, 0.8 lbf·ft)
ECM setting plate screw	0.7 N·m (0.07 kgf·m, 0.5 lbf·ft)

For tightening sequence (page 6-49)

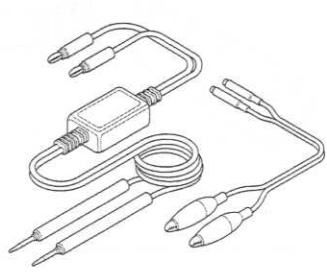
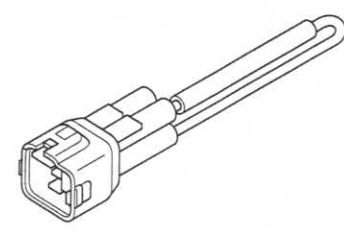
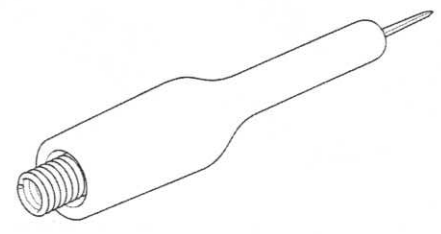
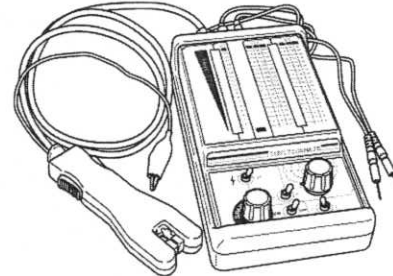
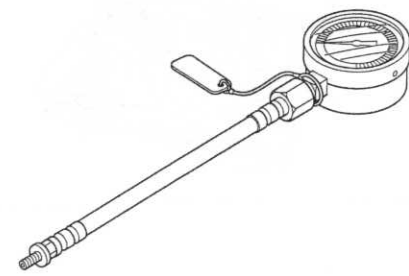
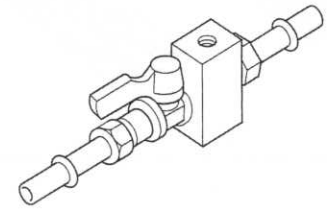
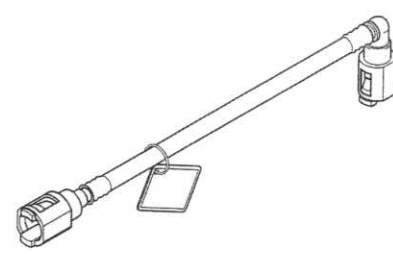
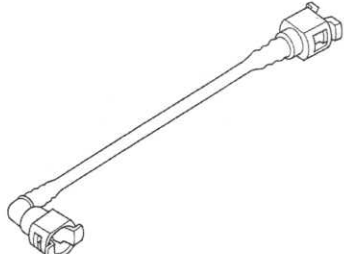
TOOLS

<p>Peak voltage adaptor 07HGJ-0020100 (Not available in U.S.A.)</p>  <p>with commercially available digital multimeter (impedance 10 MΩ/DCV minimum)</p>	<p>SCS connector 070PZ-ZY30100</p> 	<p>Test probe 07ZAJ-RDJA110</p> 
<p>IgnitionMate peak voltage tester MTP07-0286 (U.S.A. only)</p> 	<p>Fuel pressure gauge 07406-0040004</p>  <p>or 07406-004000B or 07406-004000A (U.S.A. only)</p>	<p>Pressure gauge manifold 07ZAJ-S5A0111</p>  <p>Not available in U.S.A.</p>
<p>Hose attachment, 8 mm/9 mm 07ZAJ-S7C0100</p> 	<p>Hose attachment, 9 mm/9 mm 07ZAJ-S5A0120</p>  <p>Not available in U.S.A.</p>	<p>Attachment joint, 8 mm/9 mm 07ZAJ-S7C0200</p> 

FUEL SYSTEM (PGM-FI)

Pressure manifold hose
07AMJ-HW3A100 (U.S.A. only)

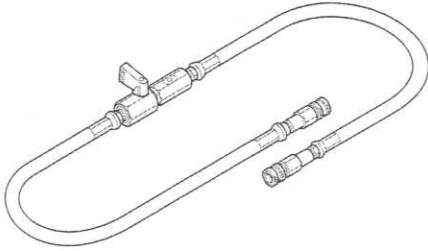

Adaptor, male
07AAJ-S6MA200 (U.S.A. only)

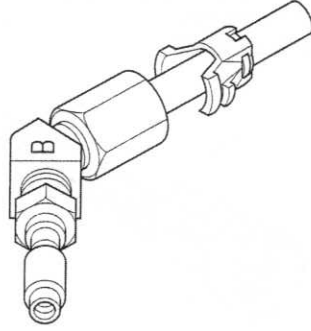

Adaptor, female
07AAJ-S6MA400 (U.S.A. only)

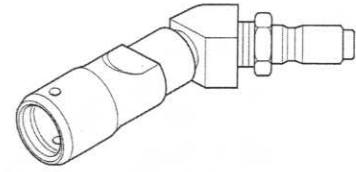

Inspection adaptor
07GMJ-ML80100

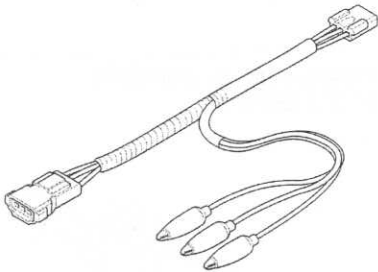

HDS pocket tester
TDS3557-0112-01 (U.S.A. only)



PGM-FI SYMPTOM TROUBLESHOOTING

When the motorcycle has one of these symptoms, check the DTC or MIL blinking, refer to the DTC index (page 6-16) and begin the appropriate troubleshooting procedure. If there are no DTC/MIL blinking stored in the ECM memory, do the diagnostic procedure for the symptom, in sequence listed below, until you find the cause.

Symptom	Diagnosis procedure	Also check for
Engine cranks but won't start (No DTC and MIL blinking)	<ol style="list-style-type: none"> 1. Crank the starter for more than 10 seconds and check the DTC (page 6-14) and execute the troubleshooting according to the DTC. 2. Inspect the fuel supply system (page 6-42). 	<ul style="list-style-type: none"> • No fuel to injector <ul style="list-style-type: none"> – Clogged fuel strainer screen – Pinched or clogged fuel hose – Pinched or clogged fuel tank breather hose – Faulty fuel pump – Faulty fuel pump circuits • Intake air leak • Contaminated/deteriorated fuel • Faulty injector • IACV stuck closed • Faulty ignition system
Engine cranks but won't start (No fuel pump operation sound when the turning the ignition ON)	<ol style="list-style-type: none"> 1. ECM power/ground circuits malfunction (page 6-75) 2. Inspect the fuel supply system (page 6-42). 	<ul style="list-style-type: none"> • Open circuit in the power input and/or ground wire of the ECM • Faulty bank angle sensor or related circuit • Faulty engine stop relay or related circuit • Faulty engine stop switch or related circuit
Engine stalls, hard to start, rough idling	<ol style="list-style-type: none"> 1. Check the idle speed. 2. Check the IACV. 3. Inspect the fuel supply system (page 6-42). 4. Inspect the battery charging system (page 17-7). 	<ul style="list-style-type: none"> • Restricted fuel hose • Contaminated/deteriorated fuel • Intake air leak • Faulty IACV • Restricted fuel tank breather hose • Faulty ignition system • Faulty battery charging system
Afterburn when engine braking is used	Check the PAIR system (page 6-77).	<ul style="list-style-type: none"> • Faulty PAIR system <ul style="list-style-type: none"> – Faulty PAIR control solenoid valve – Faulty PAIR check valve – Clogged hose of the PAIR system • Faulty ignition system
Backfiring or misfiring during acceleration	Check the ignition system.	<ul style="list-style-type: none"> • Faulty ignition system
Poor performance (driveability) and poor fuel economy	<ol style="list-style-type: none"> 1. Inspect the fuel supply system (page 6-42). 2. Inspect the air cleaner element (page 4-8). 	<ul style="list-style-type: none"> • Pinched or clogged fuel hose • Faulty pressure regulator • Faulty injector • Faulty ignition system • Clogged air cleaner element
Idle speed is below specifications or fast idle too low (No DTC and MIL blinking)	<ol style="list-style-type: none"> 1. Check the idle speed 2. Check the IACV 	<ul style="list-style-type: none"> • IACV stuck closed • Faulty fuel supply system • Faulty ignition system
Idle speed is above specifications or fast idle too high (No DTC and MIL blinking)	<ol style="list-style-type: none"> 1. Check the idle speed 2. Check the throttle operation and freeplay 3. Check the IACV 	<ul style="list-style-type: none"> • IACV stuck opened • Faulty ignition system • Intake air leak • Engine top end problem • Air cleaner condition
MIL stays ON but no DTCs set, or MIL never comes ON at all	Troubleshoot the MIL circuit (page 6-42).	<ul style="list-style-type: none"> • Faulty MIL circuit
MIL stays ON at all (No DTC set)	Inspect the DLC circuit.	<ul style="list-style-type: none"> • Short circuit in the DLC related wire

PGM-FI SYSTEM LOCATION

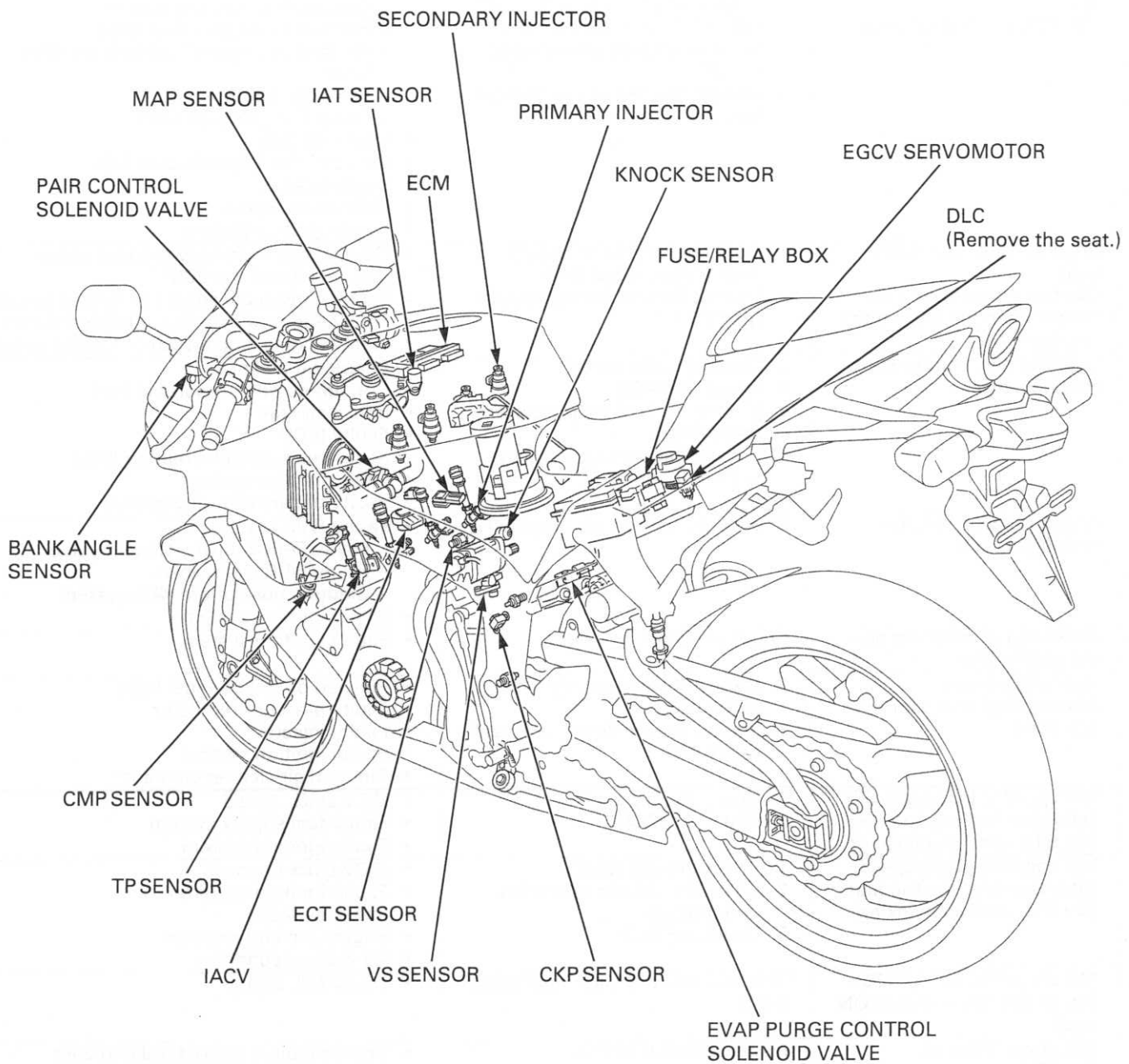

PGM-FI SYSTEM DIAGRAM

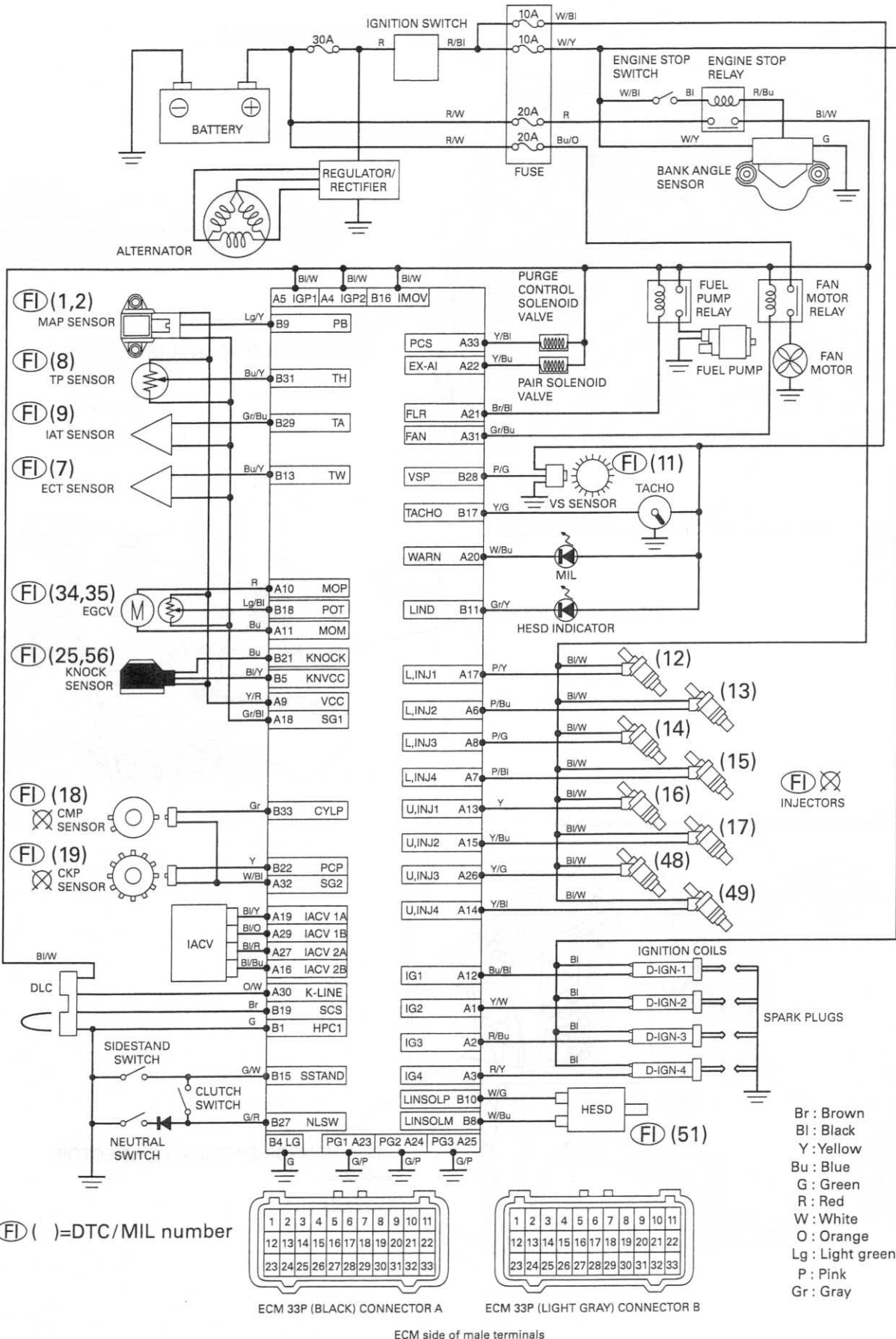

FUEL SYSTEM (PGM-FI)

CONNECTOR LOCATION

NOTE: Remove the fuel tank cover (page 3-9).

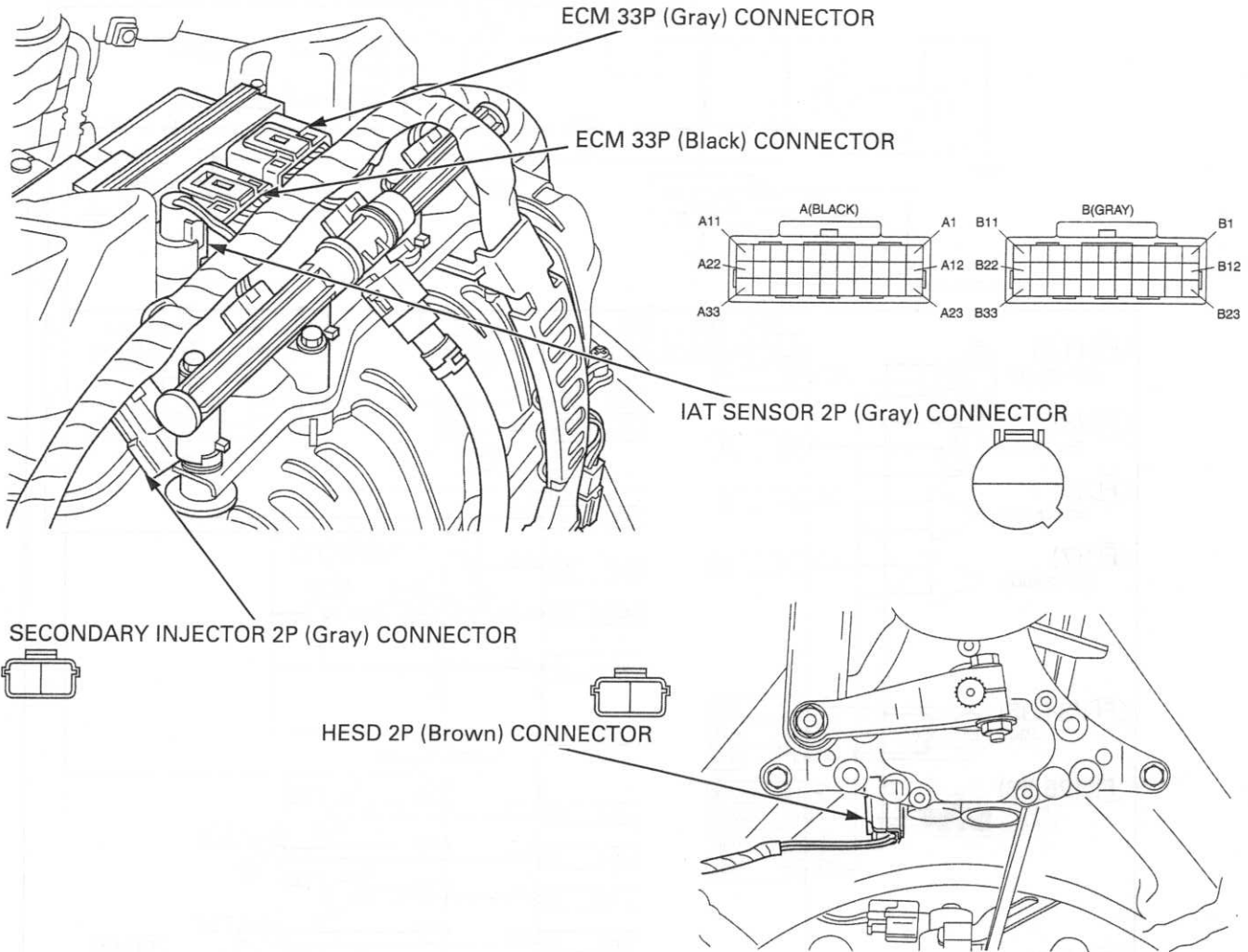

NOTE: Remove the left middle cowl (page 3-8).

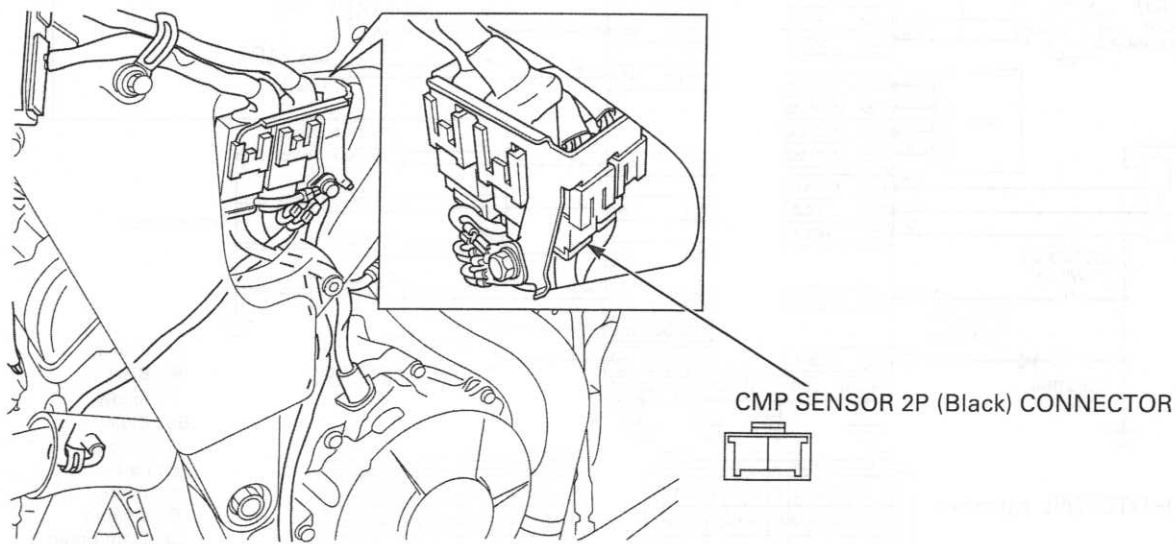

FUEL SYSTEM (PGM-FI)

NOTE: Lift and support the fuel tank (page 4-5).

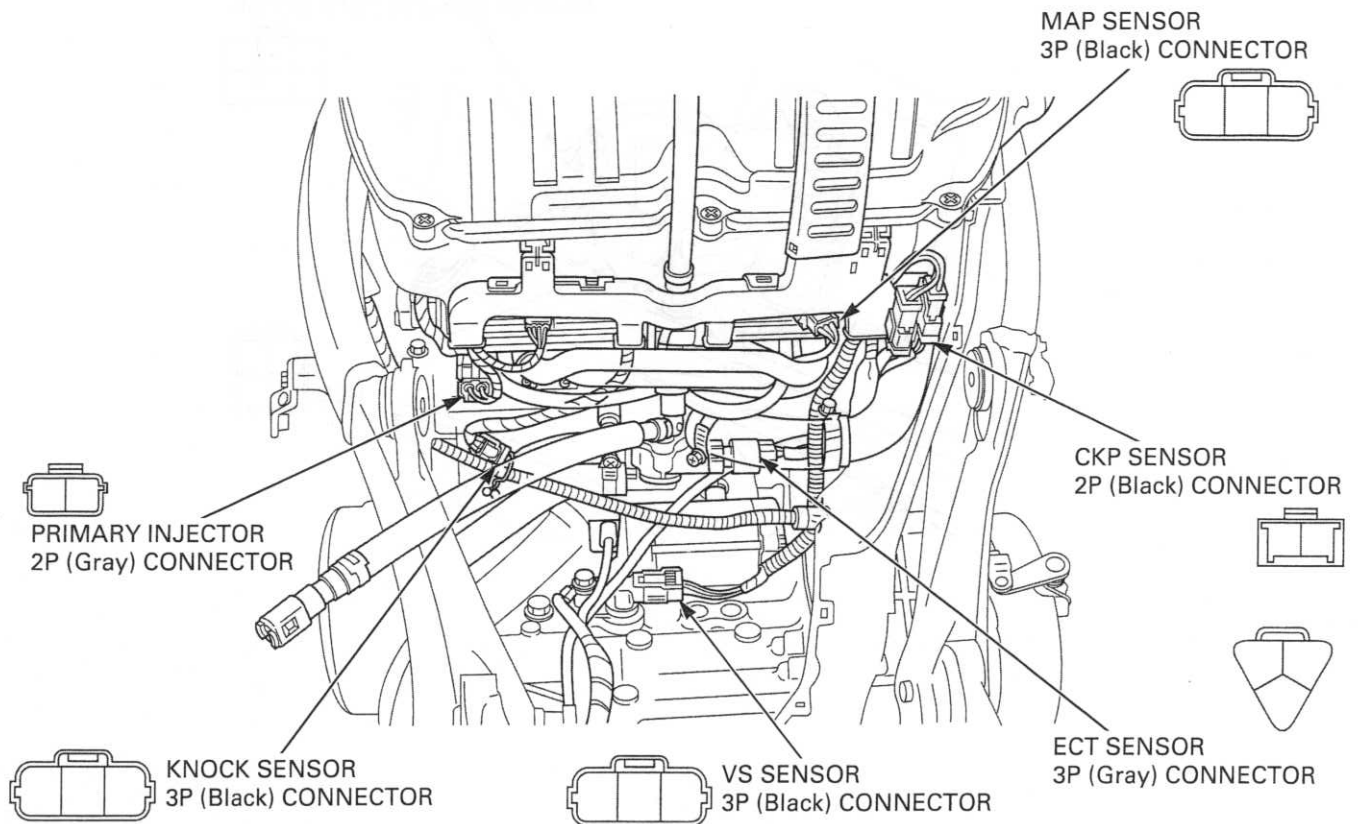

NOTE: Remove the air cleaner housing (page 6-52).

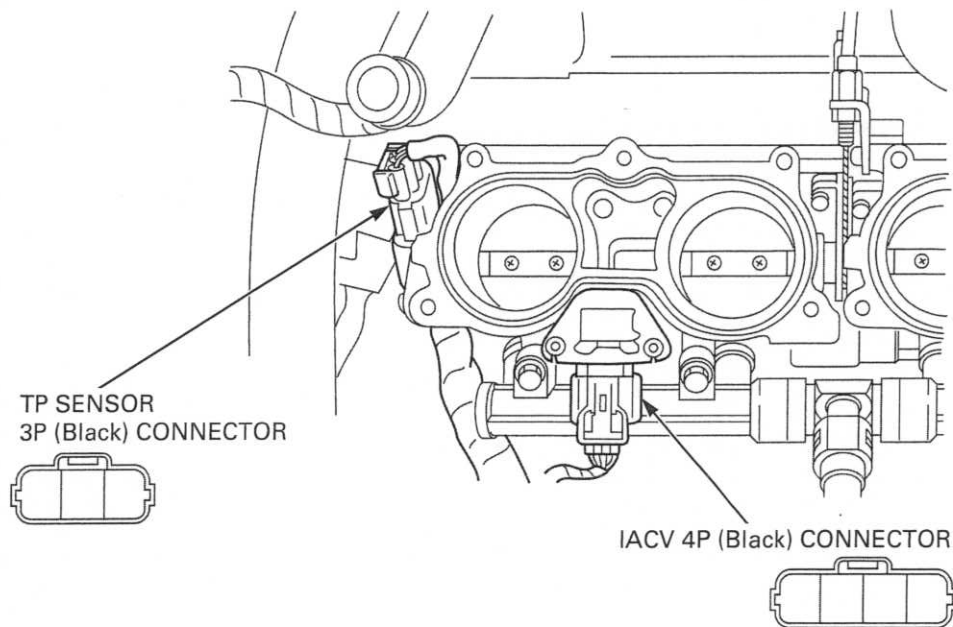

FUEL SYSTEM (PGM-FI)

NOTE: Remove the seat (page 3-4).

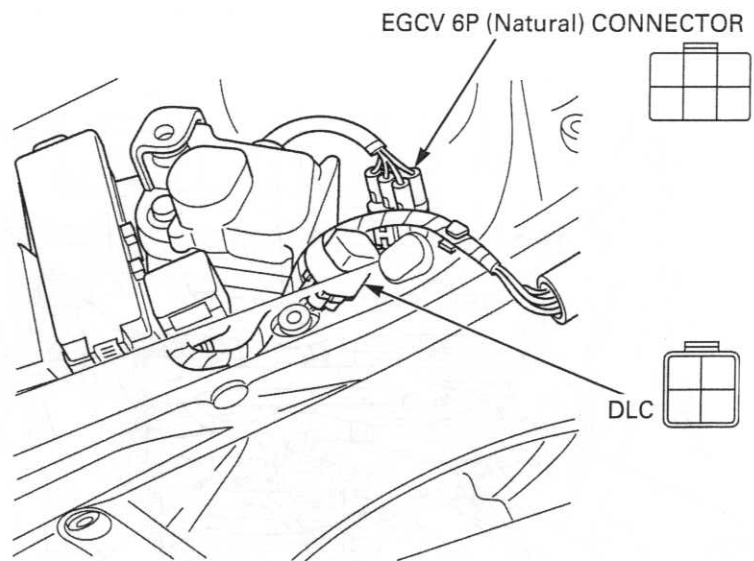

PGM-FI TROUBLESHOOTING INFORMATION

GENERAL TROUBLESHOOTING

Intermittent Failure

The term "intermittent failure" means a system may have had a failure, but it checks OK now. If the MIL does not come on, check for poor contact or loose pins at all connectors related to the circuit that of the troubleshooting. If the MIL was on, but then went out, the original problem may be intermittent.

Opens and Shorts

"Opens" and "Shorts" are common electrical terms. An open is a break in a wire or at a connection. A short is an accidental connection of a wire to ground or to another wire. In simple electronics, this usually means something will not work at all. With ECMs this can mean something may work, but not the way it's supposed to.

If the MIL has come on

Refer to DTC READOUT (page 6-14).

If the MIL did not stay on

If the MIL did not stay on, but there is a driveability problem, do the SYMPTOM TROUBLESHOOTING (page 6-7).

SYSTEM DESCRIPTION

SELF-DIAGNOSIS SYSTEM

The PGM-FI system is equipped with the self-diagnostic system. When any abnormality occurs in the system, the ECM turns on the MIL and stores a DTC in its erasable memory.

FAIL-SAFE FUNCTION

The PGM-FI system is provided with a fail-safe function to secure a minimum running capability even when there is trouble in the system. When any abnormality is detected by the self-diagnosis function, running capability is maintained by pre-programmed value in the simulated program map. When any abnormality is detected in the injector(s), CKP sensor and/or CMP sensor, the fail-safe function stops the engine to protect it from damage.

DTC (Diagnostic Trouble Code)

- The DTC is composed of a main code and a sub code and it is displayed as a hyphenated number when retrieved from the ECM with the HDS pocket tester.

The digits in front of the hyphen are the main code, they indicate the component of function failure.

The digits behind the hyphen are the sub code, they detail the specific symptom of the component or function failure.

For example, in the case of the TP sensor:

- DTC 08 - 1 = (TP sensor voltage) - (lower than the specified value)
- DTC 08 - 2 = (TP sensor voltage) - (higher than the specified value)

- The MAP, ECT, TP and IAT sensor diagnosis will be made according to the voltage output of the affected sensor.

If a failure occurs, the ECM determines the Function Failure, compares the sensor voltage output to the standard value, and then outputs the corresponding DTC to the HDS Pocket Tester.

For example:

- If the input voltage line (A) on the MAP sensor is opened, the ECM detects the output voltage is about 5 V, then the DTC 1-2 (MAP sensor circuit high voltage) will be displayed.
- If the input voltage line (B) on the TP sensor is opened, the ECM detects the output voltage is 0 V, then the DTC 8-1 (TP sensor circuit low voltage) will be displayed.

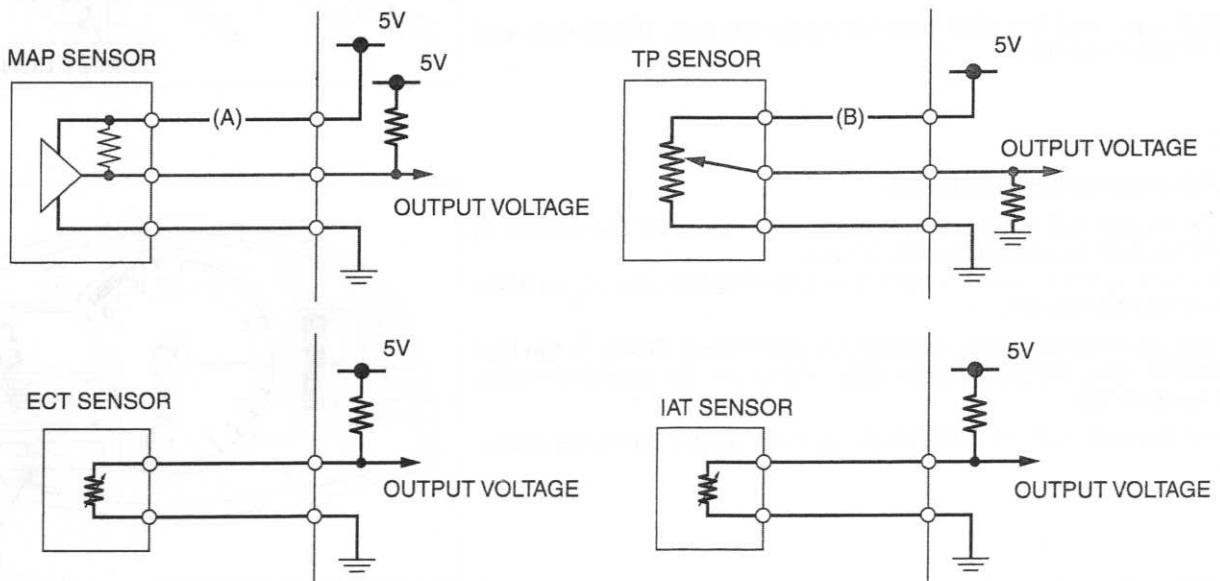

FUEL SYSTEM (PGM-FI)

MIL Blink Pattern

- If the HDS pocket tester is not available, DTC can be read from the ECM memory by the MIL blink pattern.
- The number of MIL blinks is the equivalent the main code of the DTC (the sub code cannot be displayed by the MIL).
- The MIL will blink the current DTC, in case the ECM detects the problem at present, when the ignition switch ON or idling with the sidestand down. The MIL will stay ON when the engine speed is over 5,000 rpm or with the sidestand up.
- The MIL has two types of blinks, a long blink and short blink. The long blinking lasts for 1.3 seconds, the short blinking lasts for 0.5 seconds. One long blink is the equivalent of ten short blinks. For example, when two long blinks are followed by five short blinks, the MIL is 25 (two long blinks = 20 blinks, plus five short blinks).
- When the ECM stores more than one DTC, the MIL will indicate them by blinking in the order from the lowest number to highest number.

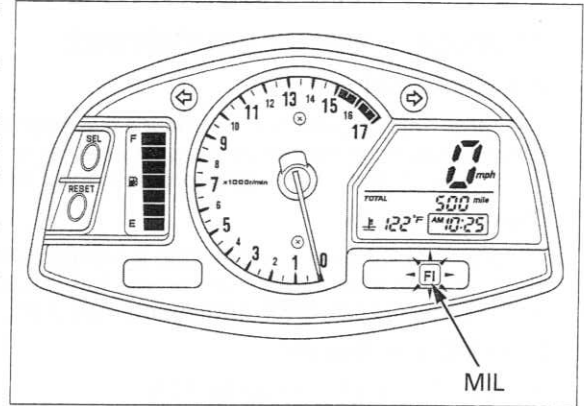

MIL Check

When the ignition switch is turned ON and engine stop switch "O", the MIL will stay on for a few seconds, then go off. If the MIL does not come on, troubleshoot the MIL circuit (page 6-42).

CURRENT DTC/FREEZE DTC

The DTC is indicated in two ways according to the failure status.

- In case the ECM detects the problem at present, the MIL will come on and the MIL will start to blink when the sidestand is lowered. It is possible to readout the MIL blink pattern as the current DTC.
- In case the ECM does not detect any problem at present but has a problem stored in its memory, the MIL will not light and blink. If it is necessary to retrieve the past problem, readout the freeze DTC by following the DTC readout procedure.

HDS POCKET TESTER INFORMATION

- The HDS can readout the DTC, freeze data, current data and other ECM condition.

How to connect the HDS Pocket Tester

Remove the seat (page 3-4).

Turn the ignition switch OFF.

Remove the dummy connector from the DLC.

Connect the HDS pocket tester to the DLC.

Turn the ignition switch ON, check the DTC and freeze data.

NOTE:

- Freeze data indicates the engine conditions when the first malfunction was detected.

ECM reset

The HDS can reset the ECM data including the DTC, freeze data and some learning memory.

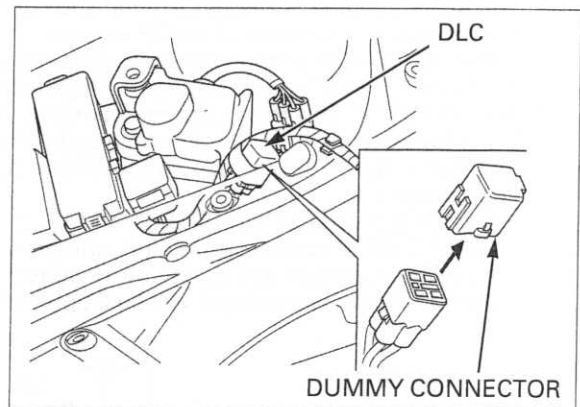

DTC READOUT

Start the engine and check the MIL.

- If the engine will not start, turn the starter motor for more than 10 seconds and check that the MIL blinks.
- When the ignition switch is turned ON, the MIL will stay on for a few seconds, then go off.

If the MIL stays on or blinks, connect the HDS Pocket Tester to the DLC (page 6-14), read the DTC, freeze data and follow the troubleshooting index (page 6-16).

To read the DTC with the MIL blinking, refer to the following procedure.

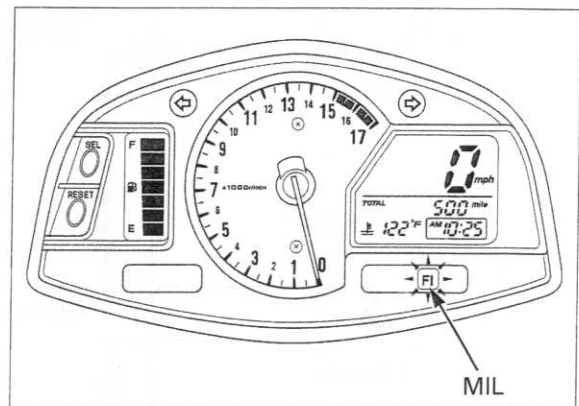

Reading DTC with the MIL

Turn the ignition switch OFF.

Remove the seat (page 3-4).

Remove the dummy connector and short DLC terminals using the special tool.

Connection: Brown – Green

TOOL:

SCS connector **070PZ-ZY30100**

Make sure the engine stop switch is turned to "O".

Turn the ignition switch ON, read, note the MIL blinks and refer to the troubleshooting index (page 6-16).

NOTE:

If the ECM has any DTC in its memory, the MIL will start blinking.

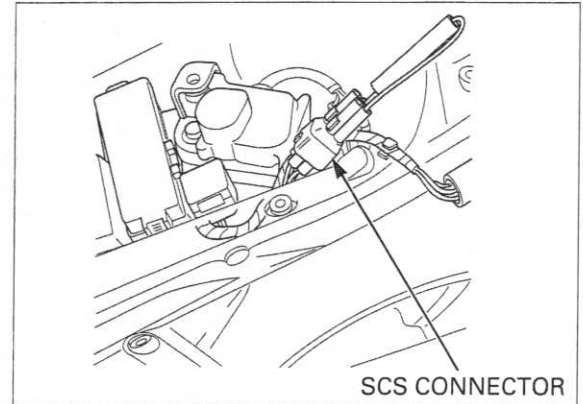

CLEARING DTC

Connect the HDS Pocket Tester to the DLC (page 6-14).

Clear the DTC with the HDS while the engine is stopped.

To clear the DTC without HDS, refer to the following procedure.

How to clear the DTC with SCS connector

1. Remove the seat (page 3-4).
2. Turn the ignition switch OFF.
3. Make sure the engine stop switch is turned to "O".

Remove the dummy connector and short the Brown and Green wire terminals of the DLC using the special tool.

Connection: Brown – Green

TOOL:

SCS connector **070PZ-ZY30100**

4. Turn the ignition switch ON.
5. Remove the special tool from the DLC.
6. The MIL will light for approximately 5 seconds. While the MIL lights, short the DLC terminals again with the special tool. The self-diagnostic memory is erased if the malfunction indicator goes off and starts blinking.

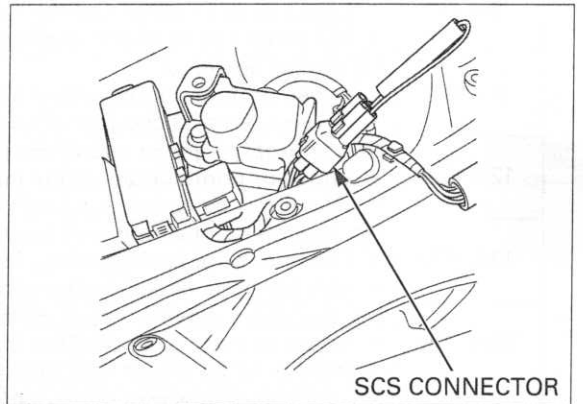

NOTE:

- The DLC must be jumped while the MIL lights. If not, the MIL will not start blinking.
- Note that the self-diagnostic memory cannot be erased if the ignition switch is turned OFF before the MIL starts blinking.

CIRCUIT INSPECTION

INSPECTION AT ECM CONNECTOR

- Always clean around and keep any foreign material away from the ECM connector before disconnecting it.
- A faulty PGM-FI system is often related to poorly connected or corroded connections. Check those connections before proceeding.
- In testing at ECM connector (wire harness side) terminal, always use the test probe. Insert the test probe into the connector terminal, then attach the digital multimeter probe to the test probe.

TOOL:

Test probe **07ZAJ-RDJA110**

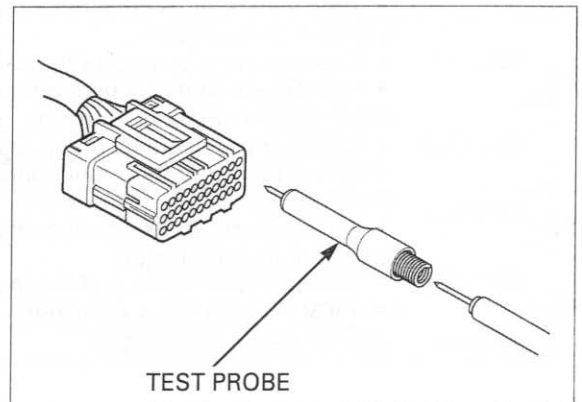

FUEL SYSTEM (PGM-FI)

DTC INDEX

DTC (MIL blinks)	Function Failure	Symptom/Fail-safe function	Refer to
1-1 (1)	MAP sensor circuit low voltage (less than 0.2 V) • MAP sensor or its circuit malfunction	• Engine operates normally	6-18
1-2 (1)	MAP sensor circuit high voltage (more than 3.9 V) • Loose or poor contact of the MAP sensor connector • MAP sensor or its circuit malfunction	• Engine operates normally	6-19
2-1 (2)	MAP sensor performance problem • Loose or poor connection of the MAP sensor vacuum hose • MAP sensor malfunction	• Engine operates normally	6-20
7-1 (7)	ECT sensor circuit low voltage (less than 0.07 V) • ECT sensor or its circuit malfunction	• Hard start at a low temperature • Pre-program value: 90°C/194°F • Cooling fan turns on	6-21
7-2 (7)	ECT sensor circuit high voltage (more than 4.93 V) • Loose or poor contact of the ECT sensor connector • ECT sensor or its circuit malfunction	• Hard start at a low temperature • Pre-program value: 90°C/194°F • Cooling fan turns on	6-22
8-1 (8)	TP sensor circuit low voltage (less than 0.3 V) • Loose or poor contact of the TP sensor connector • TP sensor or its circuit malfunction	• Poor engine acceleration • Pre-program value: 0°	6-23
8-2 (8)	TP sensor circuit high voltage (more than 4.93 V) • TP sensor or its circuit malfunction	• Poor engine acceleration • Pre-program value: 0°	6-25
9-1 (9)	IAT sensor circuit low voltage (less than 0.07 V) • IAT sensor or its circuit malfunction	• Engine operates normally • Pre-program value: 25°C/77°F	6-26
9-2 (9)	IAT sensor circuit high voltage (more than 4.93 V) • Loose or poor contact of the IAT sensor connector • IAT sensor or its circuit malfunction	• Engine operates normally • Pre-program value: 25°C/77°F	6-27
11-1 (11)	VS sensor no signal • Loose or poor contact of the VS sensor connector • VS sensor or its circuit malfunction	• Engine operates normally	6-28
12-1 (12)	No. 1 primary injector circuit malfunction • Loose or poor contact of the injector connector • Injector or its circuit malfunction	• Engine does not start • Injectors, fuel pump and ignition shut down	6-29
13-1 (13)	No. 2 primary injector circuit malfunction • Loose or poor contact of the injector connector • Injector or its circuit malfunction	• Engine does not start • Injectors, fuel pump and ignition shut down	6-31
14-1 (14)	No. 3 primary injector circuit malfunction • Loose or poor contact of the injector connector • Injector or its circuit malfunction	• Engine does not start • Injectors, fuel pump and ignition shut down	6-31
15-1 (15)	No. 4 primary injector circuit malfunction • Loose or poor contact of the injector connector • Injector or its circuit malfunction	• Engine does not start • Injectors, fuel pump and ignition shut down	6-31
16-1 (16)	No. 1 secondary injector circuit malfunction • Loose or poor contact of the injector connector • Injector or its circuit malfunction	• Engine does not start • Injectors, fuel pump and ignition shut down	6-31
17-1 (17)	No. 2 secondary injector circuit malfunction • Loose or poor contact of the injector connector • Injector or its circuit malfunction	• Engine does not start • Injectors, fuel pump and ignition shut down	6-31
18-1 (18)	CMP sensor no signal • Loose or poor contact of the CMP sensor connector • CMP sensor or its circuit malfunction	• Engine does not start • Injectors, fuel pump and ignition shut down	6-31
19-1 (19)	CKP sensor no signal • Loose or poor contact of the CKP sensor connector • CKP sensor or its circuit malfunction	• Engine does not start • Injectors, fuel pump and ignition shut down	6-32
25-2 (25)	Knock sensor circuit malfunction • Loose or poor contact of the Knock sensor connector • Knock sensor or its circuit malfunction	• Engine operates normally	6-33
25-3 (25)	Knock sensor circuit malfunction • Knock sensor or its circuit malfunction	• Engine operates normally	6-34
29-1 (29)	IACV circuit malfunction • Loose or poor contact of the IACV connector • IACV or its circuit malfunction	• Engine stalls, hard to start, rough idling	6-36
33-2 (-)	ECM EEPROM malfunction	• Engine operates normally	6-37

DTC (MIL blinks)	Function Failure	Symptom/Fail-safe function	Refer to
34-1 (34)	EGCV POT low voltage malfunction <ul style="list-style-type: none"> • Loose or poor contact of the EGCV connector • EGCV or its circuit malfunction 	<ul style="list-style-type: none"> • Engine operates normally 	6-38
34-2 (34)	EGCV POT high voltage malfunction <ul style="list-style-type: none"> • EGCV or its circuit malfunction 	<ul style="list-style-type: none"> • Engine operates normally 	6-39
35-1 (35)	EGCV servomotor malfunction <ul style="list-style-type: none"> • Loose or poor contact of the EGCV connector • EGCV or its circuit malfunction • EGCV servomotor lock 	<ul style="list-style-type: none"> • Engine operates normally 	6-40
48-1 (48)	No. 3 secondary injector circuit malfunction <ul style="list-style-type: none"> • Loose or poor contact of the injector connector • Injector its circuit malfunction 	<ul style="list-style-type: none"> • Engine does not start • Injectors, fuel pump and ignition shut down 	6-31
49-1 (49)	No. 4 secondary injector circuit malfunction <ul style="list-style-type: none"> • Loose or poor contact of the injector connector • Injector its circuit malfunction 	<ul style="list-style-type: none"> • Engine does not start • Injectors, fuel pump and ignition shut down 	6-31
51-1 (51)	HESD linear solenoid malfunction <ul style="list-style-type: none"> • Loose or poor contact of the HESD solenoid connector • HESD solenoid or its circuit 	<ul style="list-style-type: none"> • Engine operates normally • HESD does not function 	14-9
56-1 (56)	Knock sensor IC malfunction <ul style="list-style-type: none"> • Knock sensor or its circuit malfunction 	<ul style="list-style-type: none"> • Engine operates normally 	6-41

DTC TROUBLESHOOTING

DTC 1-1 (MAP SENSOR LOW VOLTAGE)

- Before starting the inspection, check for loose or poor contact on the MAP sensor 3P (Black) connector and ECM 33P connectors, then recheck the DTC.

1. MAP Sensor System Inspection

Turn the ignition switch ON and engine stop switch "O".
Check the MAP sensor with the HDS.

Is about 0 V indicated?

YES – GO TO STEP 2.

NO – Intermittent failure

2. MAP Sensor Input Voltage Inspection

Turn the ignition switch OFF.
Disconnect the MAP sensor 3P (Black) connector.

Turn the ignition switch ON and engine stop switch "O".
Measure the voltage at the wire side.

Measure the voltage at the wire side.

Connection: Yellow/red (+) – Gray/black (-)

Is the voltage within 4.75 – 5.25 V?

YES – GO TO STEP 4.

NO – GO TO STEP 3.

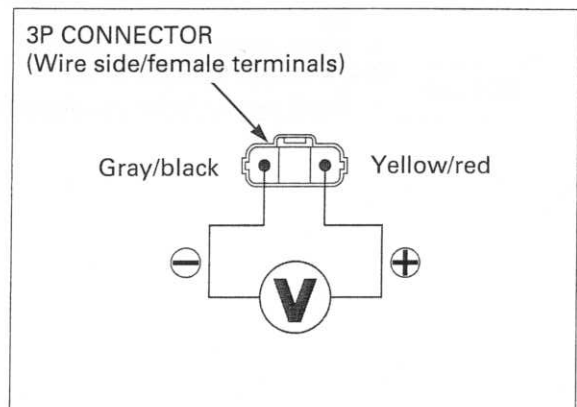

3. MAP Sensor Input Line Inspection

Turn the ignition switch OFF.
Disconnect the ECM 33P (Black) connector.

Check for continuity between the MAP sensor 3P (Black) connector and ECM 33P (Black) connector.

Connection: A9 – Yellow/red

TOOL:

Test probe

07ZAJ-RDJA110

Is there continuity?

YES – Replace the ECM with a known good one, and recheck

NO – Open circuit in Yellow/red wire

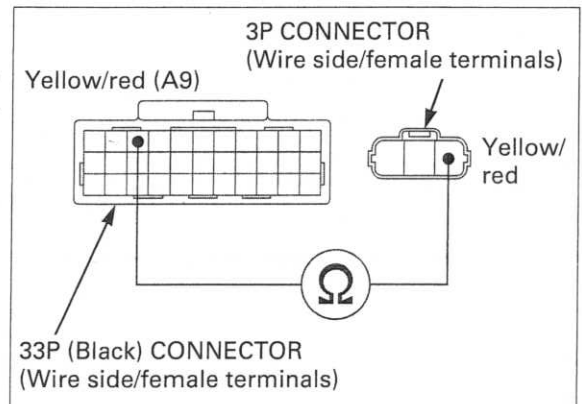

4. MAP Sensor Output Line Short Circuit Inspection

Connect the ECM 33P (Black) connector.
Check for continuity between the MAP sensor 3P (Black) connector at the wire side and ground.

Connection: Light green/yellow – Ground

Is there continuity?

- YES** – Short circuit in Light green/yellow wire
- NO** – GO TO STEP 5.

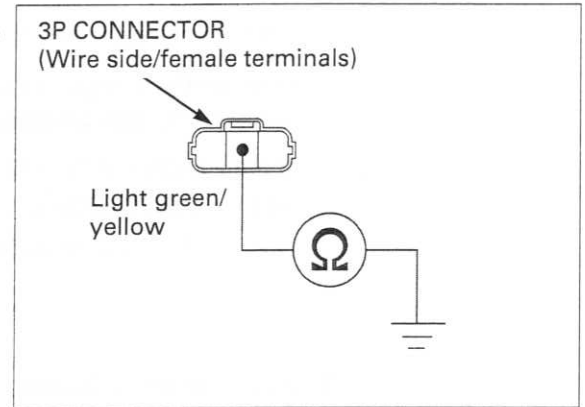

5. MAP Sensor Inspection

Replace the MAP sensor with a known good one (page 6-70).
Clear the DTC's (page 6-15).
Turn the ignition switch ON and engine stop switch "O".

Check the MAP sensor with the HDS.

Is DTC 1-1 indicated?

- YES** – Replace the ECM with a known good one, and recheck
- NO** – Faulty original MAP sensor

DTC 1-2 (MAP SENSOR HIGH VOLTAGE)

- Before starting the inspection, check for loose or poor contact on the MAP sensor 3P (Black) connector and ECM 33P connectors, then recheck the DTC.

1. MAP Sensor System Inspection 1

Turn the ignition switch ON and engine stop switch "O".

Check the MAP sensor with the HDS.

Is about 5 V indicated?

- YES** – GO TO STEP 2.
- NO** – Intermittent failure

2. MAP Sensor System Inspection 2

Turn the ignition switch OFF.

Disconnect the MAP sensor 3P (Black) connector.

Connect the MAP sensor 3P (Black) connector at the wire side with a jumper wire.

Connection: Light green/yellow – Gray/black

Turn the ignition switch ON and engine stop switch "O".

Check the MAP sensor with the HDS.

Is about 0 V indicated?

- YES** – Faulty MAP sensor
- NO** – GO TO STEP 3.

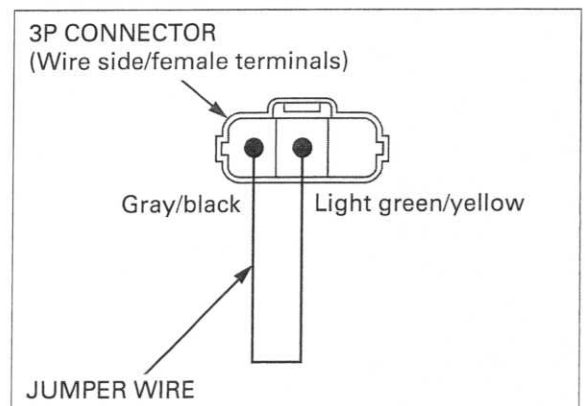

FUEL SYSTEM (PGM-FI)

3. MAP Sensor Input Voltage Inspection

Turn the ignition switch OFF.
Remove the jumper wire.

Turn the ignition switch ON and engine stop switch "O".
Measure the voltage at the wire side.

Connection: Yellow/red (+) – Gray/black (-)

Is the voltage within 4.75 – 5.25 V?

YES – GO TO STEP 4.

NO – Open circuit in Gray/black wire

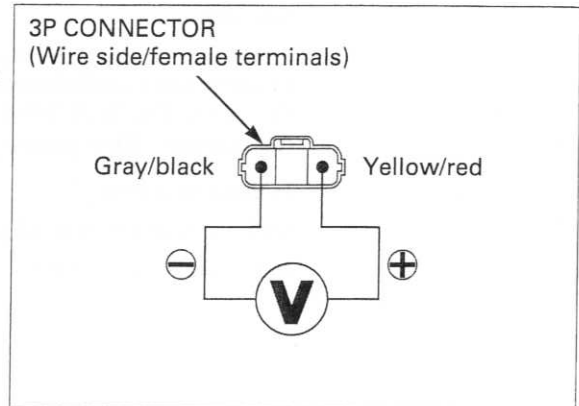

4. MAP Sensor Output Line Open Circuit Inspection

Turn the ignition switch OFF.
Disconnect the ECM 33P (Gray) connector.
Check for continuity between the MAP sensor 3P (Black) connector and ECM 33P (Gray) connector.

Connection: B9 – Light green/yellow

TOOL:

Test probe 07ZAJ-RDJA110

Is there continuity?

YES – Replace the ECM with a known good one, and recheck

NO – Open circuit in Light green/yellow wire

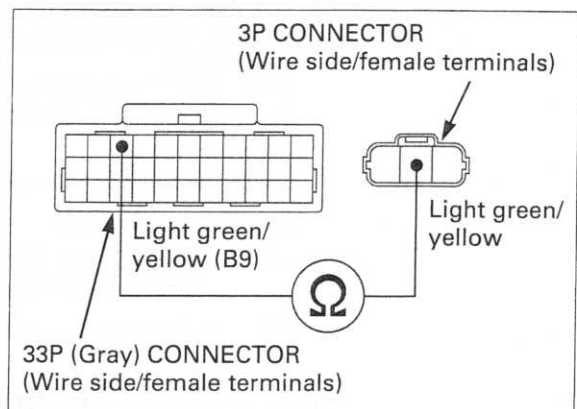

DTC 2-1 (MAP SENSOR)

- Before starting the inspection, check for loose or poor contact on the MAP sensor 3P (Black) connector and ECM 33P connectors, then recheck the DTC.

1. MAP Sensor System Inspection

Turn the ignition switch ON and engine stop switch "O".

Start the engine and check the MAP sensor with the HDS at idle speed.

Is the reading changed?

YES – Intermittent failure

NO – GO TO STEP 2.

2. Manifold Absolute Pressure Test

Turn the ignition switch OFF.

Check for connection and installation of the MAP sensor vacuum hose.

Is the MAP sensor vacuum hose connection correct?

YES – GO TO STEP 3.

NO – Correct the hose installation

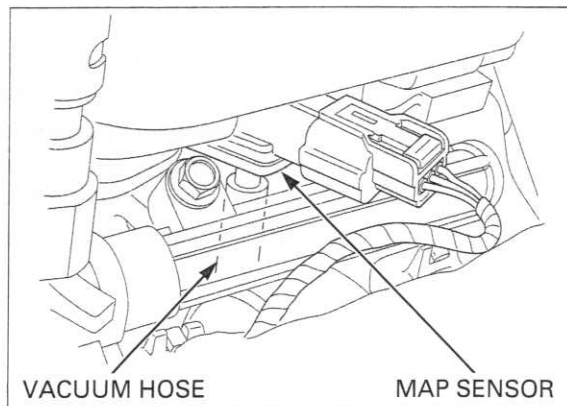

3. MAP Sensor System Inspection

Replace the MAP sensor with a known good one (page 6-70).

Turn the ignition switch ON and engine stop switch "O".

Start the engine and check the MAP sensor with the HDS at idle speed.

Is the reading changed?

YES – Faulty original MAP sensor

NO – Replace the ECM with a known good one, and recheck

DTC 7-1 (ECT SENSOR LOW VOLTAGE)

- Before starting the inspection, check for loose or poor contact on the ECT sensor 3P (Gray) connector and ECM 33P connectors, then recheck the DTC.

1. ECT Sensor System Inspection

Turn the ignition switch ON and engine stop switch "O".

Check the ECT sensor with the HDS.

Is about 0 V indicated?

YES – GO TO STEP 2.

NO – Intermittent failure

2. ECT Sensor Inspection

Turn the ignition switch OFF.

Disconnect the ECT sensor 3P (Gray) connector.

Turn the ignition switch ON and engine stop switch "O".

Check the ECT sensor with the HDS.

Is about 0 V indicated?

YES – GO TO STEP 4.

NO – GO TO STEP 3.

FUEL SYSTEM (PGM-FI)

3. ECT Sensor Resistance Inspection

Measure the resistance at the ECT sensor terminals.

Connection: Blue/yellow – Gray/black
Standard: 2.3 – 2.6 k Ω (20°C/68°F)

Is the resistance within 2.3 – 2.6 k Ω ?

- YES** – Replace the ECM with a known good one, and recheck
NO – Faulty ECT sensor

3P CONNECTOR
(Sensor side/male terminals)

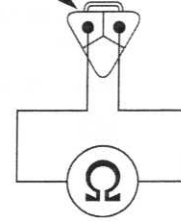

4. ECT Sensor Output Line Short Circuit Inspection

Turn the ignition switch OFF.

Check for continuity between the ECT sensor 3P (Gray) connector at the wire side and ground.

Connection: Blue/yellow – Ground

Is there continuity?

- YES** – Short circuit in Blue/yellow wire
NO – Replace the ECM with a known good one, and recheck

3P CONNECTOR
(Wire side/female terminals)

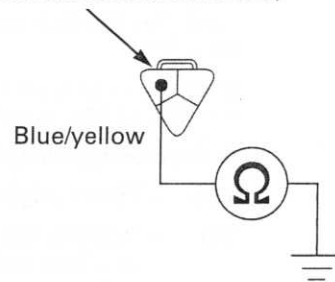

DTC 7-2 (ECT SENSOR HIGH VOLTAGE)

- Before starting the inspection, check for loose or poor contact on the ECT sensor 3P (Gray) connector and ECM 33P connectors, then recheck the DTC.

1. ECT Sensor System Inspection

Turn the ignition switch ON and engine stop switch "O".

Check the ECT sensor with the HDS.

Is about 5 V indicated?

- YES** – GO TO STEP 2.
NO – Intermittent failure

2. ECT Sensor Inspection

Turn the ignition switch OFF.

Disconnect the ECT sensor 3P (Gray) connector. Connect the ECT sensor 3P (Gray) connector at the wire side with a jumper wire.

Connection: Blue/yellow – Gray/black

Turn the ignition switch ON and engine stop switch "O".

Check the ECT sensor with the HDS.

Is about 0 V indicated?

- YES** – Inspect the ECT sensor (page 20-14)
NO – GO TO STEP 3.

Blue/yellow Gray/black

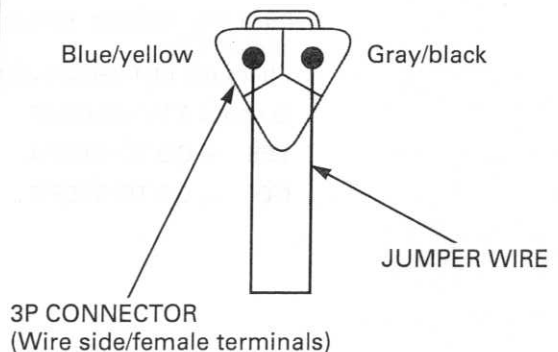

3. ECT Sensor Output Line Inspection

Turn the ignition switch OFF.
Remove the jumper wire.

Disconnect the ECM 33P connectors.
Check for continuity between the ECT sensor 3P (Gray) connector and ECM 33P connectors.

Connection: B13 – Blue/yellow
A18 – Gray/black

TOOL:
Test probe 07ZAJ-RDJA110

Is there continuity?

YES – Replace the ECM with a known good one, and recheck

NO – • Open circuit in Blue/yellow wire
• Open circuit in Gray/black wire

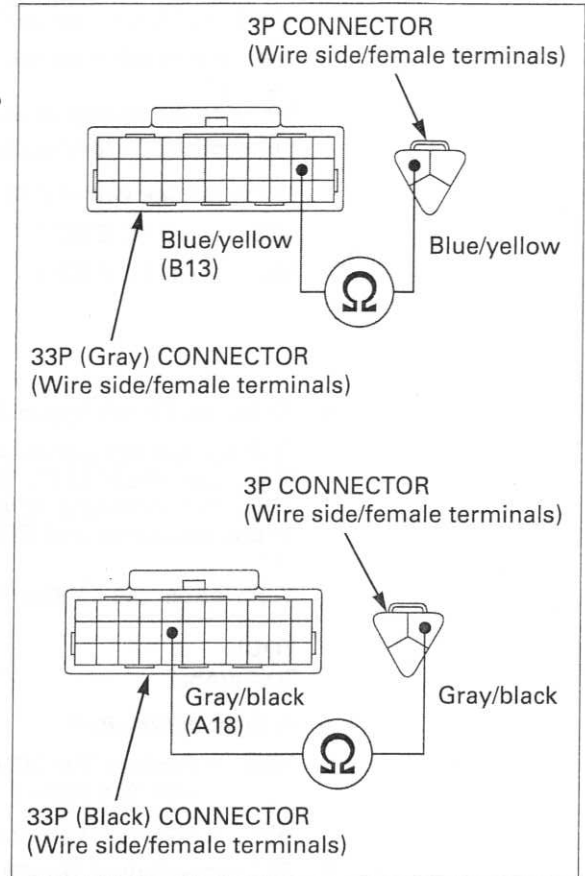

DTC 8-1 (TP SENSOR LOW VOLTAGE)

- Before starting the inspection, check for loose or poor contact on the TP sensor 3P (Black) connector and ECM 33P connectors, then recheck the DTC.

1. TP Sensor System Inspection

Turn the ignition switch ON and engine stop switch "O".

Check the TP sensor with the HDS when the throttle is fully closed.

Is about 0 V indicated?

YES – GO TO STEP 3.

NO – GO TO STEP 2.

2. TP Sensor Inspection

Check that the TP sensor voltage increases continuously when moving the throttle from fully closed to fully opened using the data list menu of the HDS.

Does the voltage increase continuously?

YES – Intermittent failure

NO – Faulty TP sensor

FUEL SYSTEM (PGM-FI)

3. TP Sensor Input Voltage Inspection

Turn the ignition switch OFF.
Disconnect the TP sensor 3P (Black) connector.
Turn the ignition switch ON and engine stop switch "O".
Measure the voltage at the wire side.

Connection: Yellow/red (+) – Gray/black (-)

Is the voltage within 4.75 – 5.25 V?

YES – GO TO STEP 5.

NO – GO TO STEP 4.

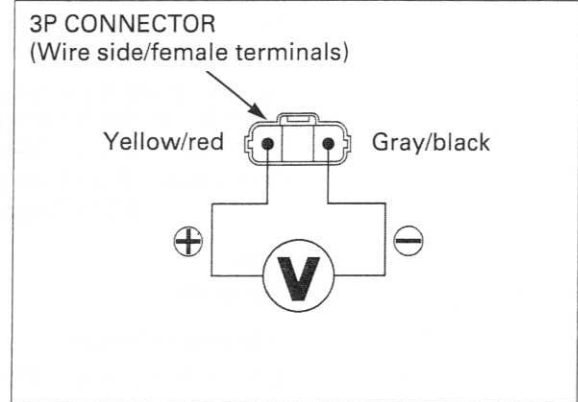

4. TP Sensor Circuit Inspection

Turn the ignition switch OFF.
Disconnect the ECM 33P (Black) connector.
Check for continuity between the TP sensor 3P (Black) connector and ECM 33P (Black) connector.

Connection: A9 – Yellow/red

TOOL:

Test probe 07ZAJ-RDJA110

Is there continuity?

YES – Replace the ECM with a known good one, and recheck

NO – Open circuit in Yellow/red wire

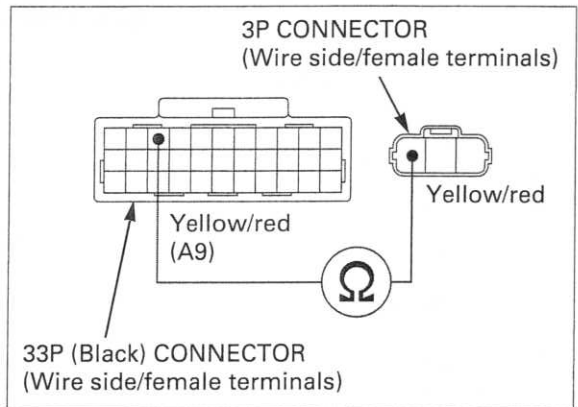

5. TP Sensor Output Line Open Circuit Inspection

Turn the ignition switch OFF.
Disconnect the ECM 33P (Gray) connector.
Check for continuity between the TP sensor 3P (Black) connector and ECM 33P (Gray) connector.

Connection: B31 – Blue/yellow

TOOL:

Test probe 07ZAJ-RDJA110

Is there continuity?

YES – GO TO STEP 6.

NO – Open circuit in Blue/yellow wire

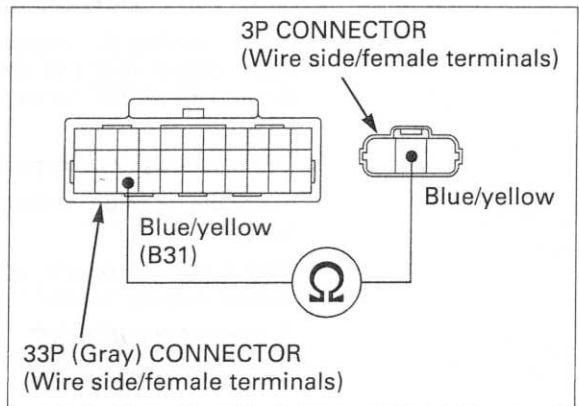

6. TP Sensor Output Line Short Circuit Inspection

Disconnect the TP sensor 3P (Black) connector.
Connect the ECM 33P (Gray) connector.

Check for continuity between the TP sensor 3P connector at the wire side and ground.

Connection: Blue/yellow – Ground

Is there continuity?

YES – Short circuit in Blue/yellow wire

NO – GO TO STEP 7.

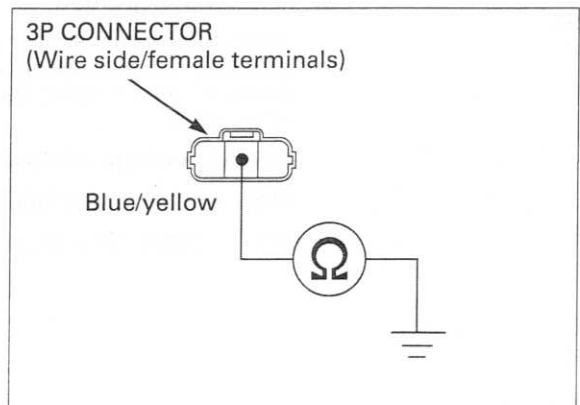

7. TP Sensor Inspection

Replace the throttle body (page 6-60).
Clear the DTC's (page 6-15).

Turn the ignition switch ON and engine stop switch "O".

Check the TP sensor with the HDS.

Is DTC 8-1 indicated?

YES – Replace the ECM with a known good one, and recheck

NO – Faulty original TP sensor

DTC 8-2 (TP SENSOR HIGH VOLTAGE)

- Before starting the inspection, check for loose or poor contact on the TP sensor 3P (Black) connector and ECM 33P connectors, then recheck the DTC.

1. TP Sensor System Inspection

Turn the ignition switch ON and engine stop switch "O".

Check the TP sensor with the HDS.

Is about 5 V indicated?

YES – GO TO STEP 3.

NO – GO TO STEP 2.

2. TP Sensor Inspection

Check that the TP sensor voltage increases continuously when moving the throttle from fully closed to fully opened using the data list menu of the HDS.

Does the voltage increase continuously?

YES – Intermittent failure

NO – Faulty TP sensor

3. TP Sensor Resistance Inspection

Turn the ignition switch OFF.

Disconnect the TP sensor 3P (Black) connector. Measure the resistance at the TP sensor side.

Connection: Blue/yellow – Gray/black

Is the resistance within 0.5 - 1.5 kΩ?

YES – GO TO STEP 4.

NO – Faulty TP sensor

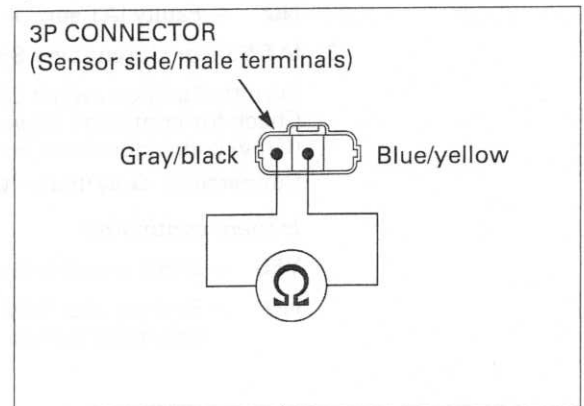

FUEL SYSTEM (PGM-FI)

4. TP Sensor Input Voltage Inspection

Turn the ignition switch ON and engine stop switch "O".
Measure the voltage at the wire side.

Connection: Yellow/red (+) – Gray/black (-)

Is the voltage within 4.75 – 5.25 V?

YES – Replace the ECM with a known good one, and recheck

NO – Open circuit in Gray/black wire

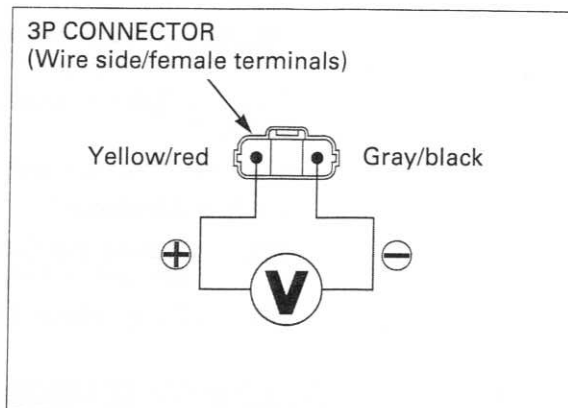

DTC 9-1 (IAT SENSOR LOW VOLTAGE)

- Before starting the inspection, check for loose or poor contact on the IAT sensor 2P (Gray) connector and ECM 33P connectors, then recheck the DTC.

1. IAT Sensor System Inspection

Turn the ignition switch ON and engine stop switch "O".

Check the IAT sensor with the HDS.

Is about 0 V indicated?

YES – GO TO STEP 2.

NO – Intermittent failure

2. IAT Sensor Inspection

Turn the ignition switch OFF.
Disconnect the IAT sensor 2P (Gray) connector.

Turn the ignition switch ON and engine stop switch "O".

Check the IAT sensor with the HDS.

Is about 0 V indicated?

YES – GO TO STEP 3.

NO – Faulty IAT sensor

3. IAT Sensor Output Line Short Circuit Inspection

Turn the ignition switch OFF.
Check for continuity between the IAT sensor 2P (Gray) connector at the wire side and ground.

Connection: Gray/blue – Ground

Is there continuity?

YES – Short circuit in Gray/blue wire

NO – Replace the ECM with a known good one, and recheck

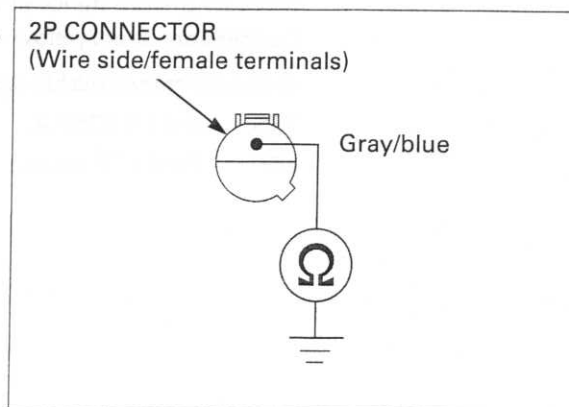

DTC 9-2 (IAT SENSOR HIGH VOLTAGE)

- Before starting the inspection, check for loose or poor contact on the IAT sensor 2P (Gray) connector and ECM 33P connectors, then recheck the DTC.

1. IAT Sensor System Inspection

Turn the ignition switch ON and engine stop switch "O".

Check the IAT sensor with the HDS.

Is about 5 V indicated?

YES – GO TO STEP 2.

NO – Intermittent failure

2. IAT Sensor Inspection

Turn the ignition switch OFF.

Disconnect the IAT sensor 2P (Gray) connector. Connect the IAT sensor 2P (Gray) connector at the wire side with a jumper wire.

Connection: Gray/blue – Gray/black

Turn the ignition switch ON and engine stop switch "O".

Check the IAT sensor with the HDS.

Is about 0 V indicated?

YES – Faulty IAT sensor

NO – GO TO STEP 3.

3. IAT Sensor Line Inspection

Turn the ignition switch OFF.

Disconnect the ECM 33P connectors.

Check for continuity between the IAT sensor 2P (Gray) connector and ECM 33P connectors.

Connection: B29 – Gray/blue

A18 – Gray/black

TOOL:

Test probe **07ZAJ-RDJA110**

Is there continuity?

YES – Replace the ECM with a known good one, and recheck

NO – • Open circuit in Gray/blue wire
• Open circuit in Gray/black wire

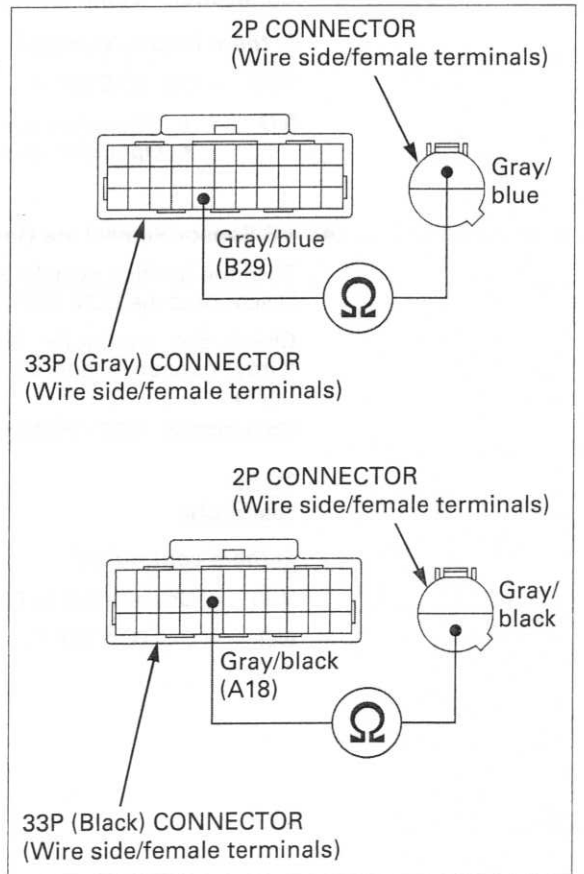
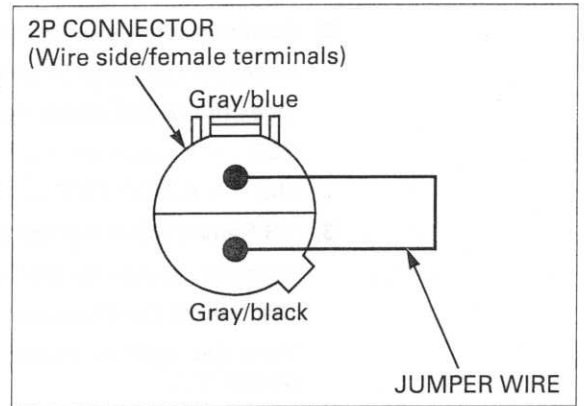

DTC 11-1 (VS SENSOR)

- Before starting the inspection, check for loose or poor contact on the VS sensor 3P (Black) connector and ECM 33P connectors, then recheck the DTC.

1. VS Sensor System Inspection

Support the motorcycle securely, raise the rear wheel off the ground.
Start the engine and shift the transmission into gear.

Check the VS sensor with the HDS at 6 mph (10 km/h).

Is 6 mph (10 km/h) indicated?

YES – Intermittent failure

NO – GO TO STEP 2.

2. Combination Meter Inspection

Check for operation of speedometer.

Does the speedometer operate normally?

YES – Open or short circuit in Pink/green wire

NO – GO TO STEP 3.

3. VS Sensor Input Voltage Inspection

Turn the ignition switch OFF.

Disconnect the VS sensor 3P (Black) connector.

Turn the ignition switch ON and engine stop switch "O".

Measure the voltage at the wire side.

Connection: Violet (+) – Green/black (-)

Is there battery voltage?

YES – GO TO STEP 4.

NO –

- Open circuit in Violet wire
- Open circuit in Green/black wire

4. VS Sensor Signal Line Open Circuit Inspection

Turn the ignition switch OFF.

Disconnect the ECM 33P (Gray) connector.

Check the continuity between the ECM 33P (Gray) connector and VS sensor 3P (Black) connector.

Connection: B28 – Pink/green

TOOL:

Test probe

07ZAJ-RDJA110

Is there continuity?

YES – Open circuit in Pink/green wire

NO – GO TO STEP 5.

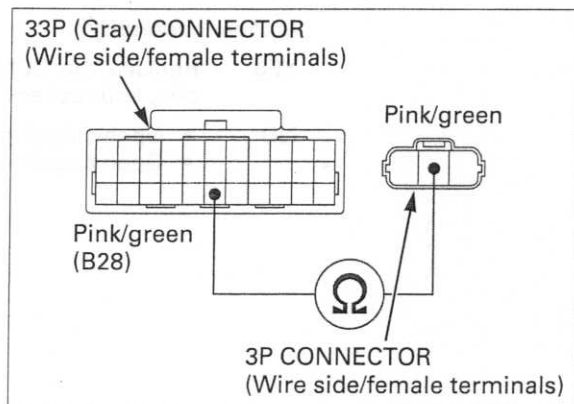
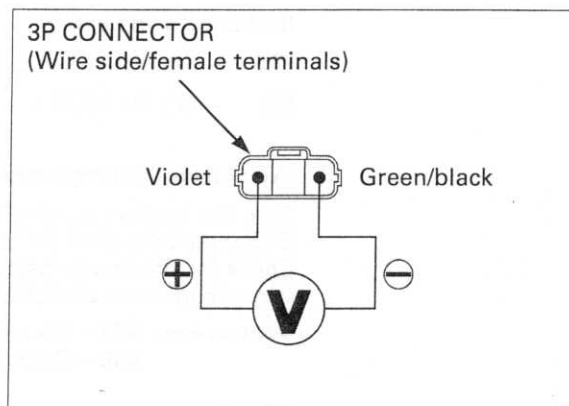

5. VS Sensor Signal Line Short Circuit Inspection

Turn the ignition switch OFF.
 Connect the ECM 33P (Gray) connector.
 Check for continuity between the VS sensor 3P (Black) connector at the wire side and ground.

Connection: Pink/green – Ground

Is there continuity?

YES – Short circuit in Pink/green wire

NO – Inspect VS sensor (page 20-11)

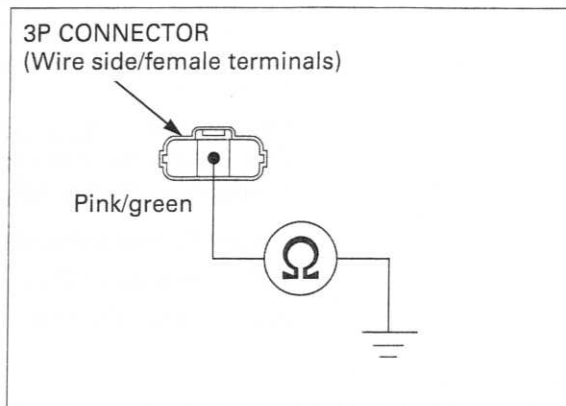

DTC 12-1 (No.1 PRIMARY INJECTOR)

- Before starting the inspection, check for loose or poor contact on the injector 2P (Gray) connectors and ECM 33P connectors, then recheck the DTC.

DTC	INJECTOR	POWER INPUT LINE	SIGNAL LINE	SIGNAL AT ECM
12-1	No.1 Primary	Black/white	Pink/yellow	A17
13-1	No.2 Primary	Black/white	Pink/blue	A6
14-1	No.3 Primary	Black/white	Pink/green	A8
15-1	No.4 Primary	Black/white	Pink/black	A7
16-1	No.1 Secondary	Black/white	Yellow	A13
17-1	No.2 Secondary	Black/white	Yellow/blue	A15
48-1	No.3 Secondary	Black/white	Yellow/green	A26
49-1	No.4 Secondary	Black/white	Yellow/black	A14

1. Injector System Inspection

Clear the DTC's (page 6-15).
 Start the engine and check the injector with the HDS.

Is the DTC 12-1 indicated?

YES – GO TO STEP 2.

NO – Intermittent failure

FUEL SYSTEM (PGM-FI)

2. Injector Input Voltage Inspection

Turn the ignition switch OFF.

Disconnect the injector 2P (Gray) connector.
Turn the ignition switch ON and engine stop switch "O".

Measure the voltage between the injector 2P (Gray) connector at the wire side and ground.

Connection: Black/white (+) – Ground (-)

Is there battery voltage?

YES – GO TO STEP 3.

NO – Open circuit in Black/white wire

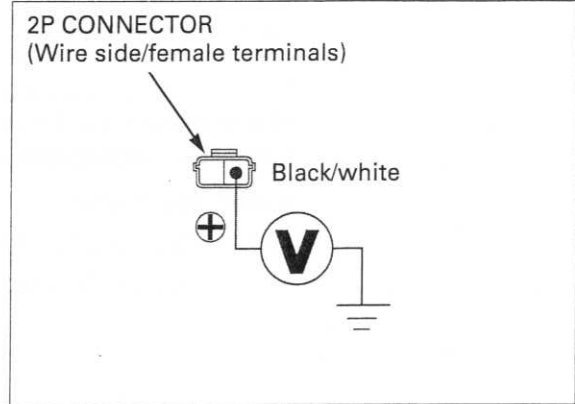

3. Injector Resistance Inspection

Turn the ignition switch OFF.

Measure the resistance of the injector 2P connector terminals.

Is the resistance within 11 – 13 Ω (20°C/68°F)?

YES – GO TO STEP 4.

NO – Faulty injector

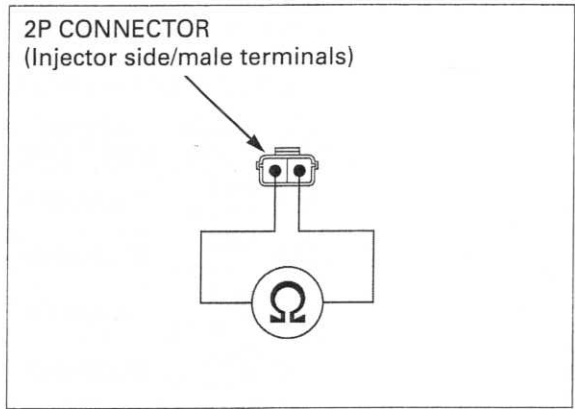

4. Injector Signal Line Open Circuit Inspection

Disconnect the ECM 33P (Black) connector.
Check for continuity between the ECM 33P (Black) connector and injector 2P (Gray) connector.

Connection: SIGNAL LINE – SIGNAL AT ECM

TOOL:

Test probe 07ZAJ-RDJA110

Is there continuity?

YES – GO TO STEP 5.

NO – Open circuit in SIGNAL LINE wire

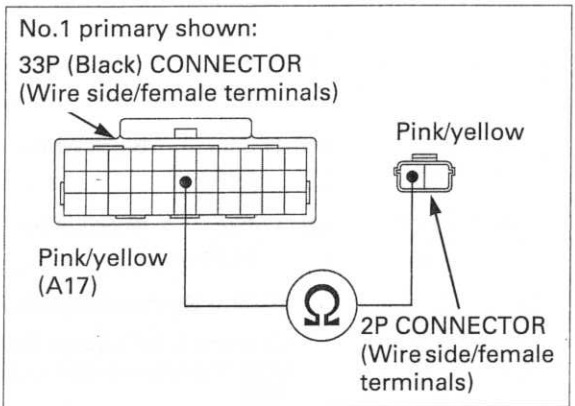

5. Injector Signal Line Short Circuit Inspection

Connect the ECM 33P (Black) connector.
Check for continuity between the injector 2P (Gray) connector at the wire side and ground.

Connection: SIGNAL LINE – Ground

Is there continuity?

YES – • Short circuit in SIGNAL LINE wire
• Faulty injector

NO – Replace the ECM with a known good one, and recheck

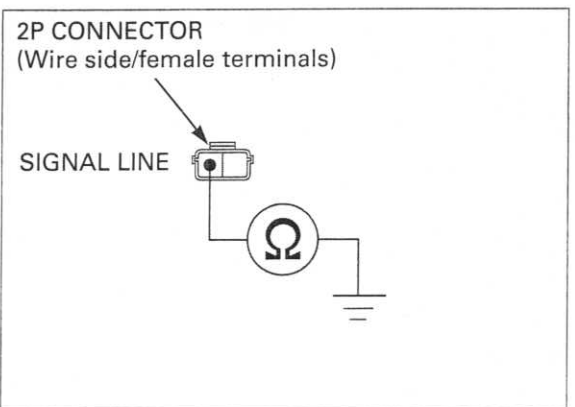

DTC 13-1 (No.2 PRIMARY INJECTOR)

(page 6-29)

DTC 14-1 (No.3 PRIMARY INJECTOR)

(page 6-29)

DTC 15-1 (No.4 PRIMARY INJECTOR)

(page 6-29)

DTC 16-1 (No.1 SECONDARY INJECTOR)

(page 6-29)

DTC 17-1 (No.2 SECONDARY INJECTOR)

(page 6-29)

DTC 48-1 (No.3 SECONDARY INJECTOR)

(page 6-29)

DTC 49-1 (No.4 SECONDARY INJECTOR)

(page 6-29)

DTC 18-1 (CMP SENSOR)

- Before starting the inspection, check for loose or poor contact on the CMP sensor 2P (Black) connector and ECM 33P connectors, then recheck the DTC.

1. CMP sensor Peak Voltage Inspection

Turn the ignition switch OFF.
Disconnect the CMP sensor 2P (Black) connector.

Turn the ignition switch ON.
Crank the engine and measure the CMP sensor peak voltage at the CMP sensor 2P (Black) connector.

Connection: Gray (+) – White (-)

TOOLS:

IgnitionMate peak voltage tester	MTP07-0286 (U.S.A. only) or
Peak voltage adaptor	07HGJ-0020100 (Not available in U.S.A.)

with commercially available digital multimeter (impedance 10 M Ω /DCV minimum)

Is the voltage more than 0.7 V (20°C/68°F)?

YES – GO TO STEP 2.

NO – Faulty CMP sensor

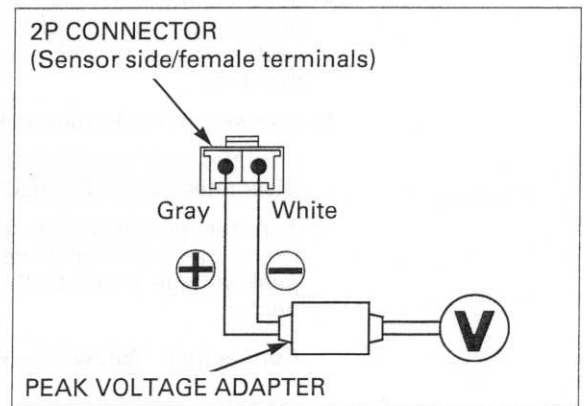

FUEL SYSTEM (PGM-FI)

2. CMP sensor Circuit Inspection

Turn the ignition switch OFF.
Disconnect the ECM 33P connectors.

Check for continuity between the CMP sensor 2P (Black) connector and ECM 33P connectors.

Connection: B33 – Gray
A32 – White/black

TOOL:

Test probe 07ZAJ-RDJA110

Is there continuity?

- YES** – Short circuit in Gray wire
- NO** – • Open circuit in White/black wire
• Open circuit in Gray wire

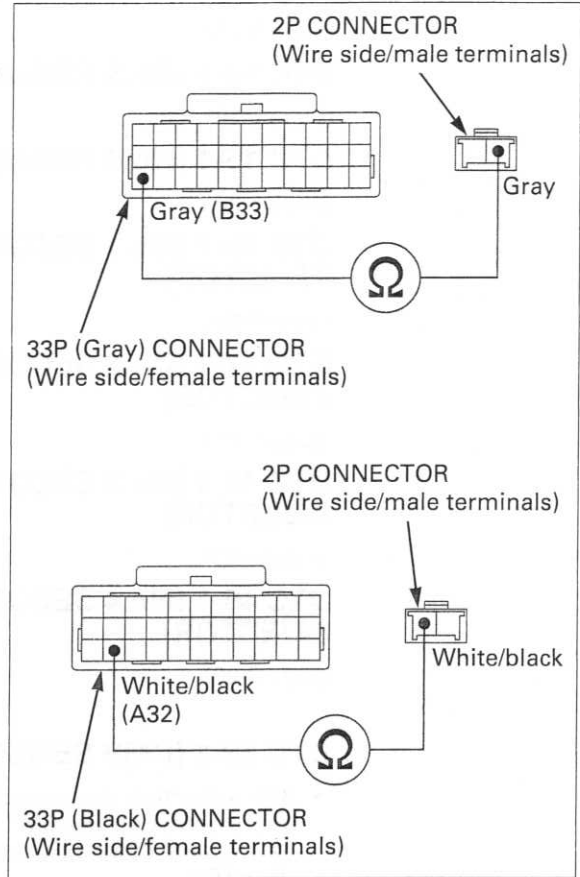

DTC 19-1 (CKP SENSOR)

- Before starting the inspection, check for loose or poor contact on the CKP sensor 2P (Black) connector and ECM 33P connectors, then recheck the DTC.

1. CKP sensor Peak Voltage Inspection

Turn the ignition switch OFF.
Disconnect the CKP sensor 2P (Black) connector.

Turn the ignition switch ON.
Crank the engine and measure the CKP sensor peak voltage at the CKP sensor 2P (Black) connector.

Connection: Yellow (+) – White/yellow (-)

TOOLS:

IgnitionMate peak voltage tester MTP07-0286 (U.S.A. only) or 07HGJ-0020100 (Not available in U.S.A.)

Peak voltage adaptor

with commercially available digital multimeter (impedance 10 MΩ/DCV minimum)

Is the voltage more than 0.7 V (20°C/68°F)?

- YES** – GO TO STEP 2.
- NO** – Faulty CKP sensor

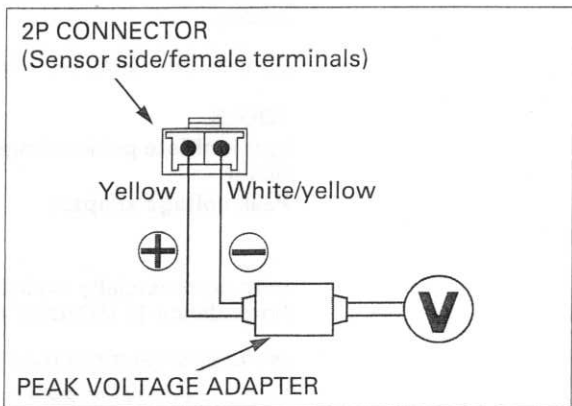

2. CKP sensor Circuit Inspection

Turn the ignition switch OFF.
Disconnect the ECM 33P connectors.

Check for continuity between the CKP sensor 2P (Black) connector and ECM 33P connectors.

Connection: B22 – Yellow
A32 – White/black

TOOL:

Test probe 07ZAJ-RDJA110

Is there continuity?

- YES** – Short circuit in Yellow wire
- NO** – • Open circuit in Yellow wire
• Open circuit in White/black wire

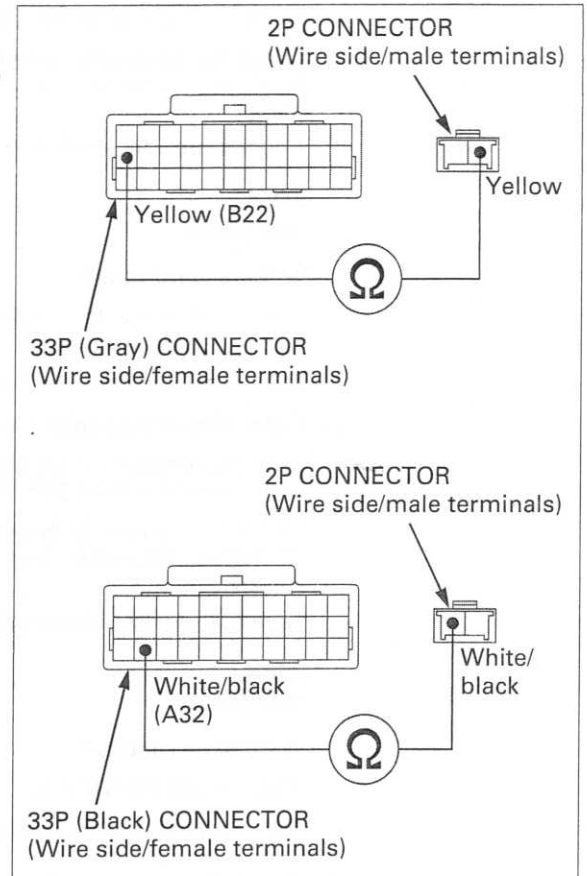

DTC 25-2 (KNOCK SENSOR NO INPUT VOLTAGE)

- Before starting the inspection, check for loose or poor contact on the Knock sensor 3P (Black) connector and ECM 33P connectors, then recheck the DTC.

1. Knock Sensor System Inspection

Clear the DTC's (page 6-15).
Place the motorcycle on its sidestand.

Start the engine and recheck the Knock sensor with the HDS.

Is the DTC 25-2 indicated?

- YES** – GO TO STEP 2.
- NO** – Intermittent failure

2. Knock Sensor Input Voltage Inspection

Turn the ignition switch OFF.
Disconnect the Knock sensor 3P (Black) connector.

Turn the ignition switch ON and engine stop switch "O".
Measure the voltage at the wire side.

Connection: Yellow/red (+) – Ground (-)

Is the voltage within 4.75 – 5.25 V?

- YES** – GO TO STEP 4.
- NO** – GO TO STEP 3.

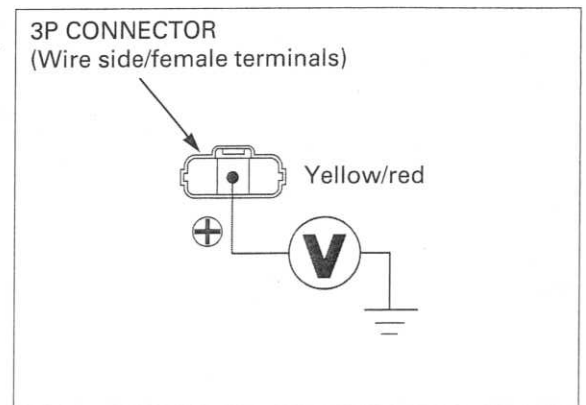

FUEL SYSTEM (PGM-FI)

3. Knock Sensor Input Line Inspection

Turn the ignition switch OFF.
Disconnect the ECM 33P (Black) connector.

Check for continuity between the Knock sensor 3P (Black) connector and ECM 33P (Black) connector.

Connection: A9 – Yellow/red

TOOL:
Test probe 07ZAJ-RDJA110

Is there continuity?

YES – Replace the ECM with a known good one, and recheck

NO – Open circuit in Yellow/red wire

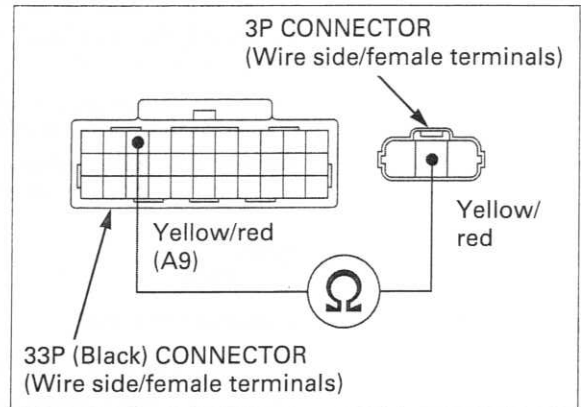

4. Open Circuit Detection Line Inspection

Turn the ignition switch OFF.
Disconnect the ECM 33P (Gray) connector.

Check for continuity between the Knock sensor 3P (Black) connector and ECM 33P (Gray) connector.

Connection: B5 – Black/yellow

TOOL:
Test probe 07ZAJ-RDJA110

Is there continuity?

YES – GO TO STEP 5.

NO – Open circuit in Black/yellow wire

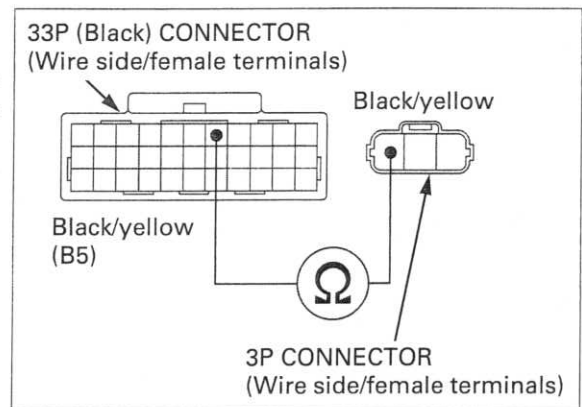

5. Knock Sensor Inspection

Check for continuity at the Knock sensor 3P (Black) connector terminals.

Connection: Yellow/red – Black/yellow

Is there continuity?

YES – Replace the ECM with a known good one, and recheck

NO – Faulty Knock sensor

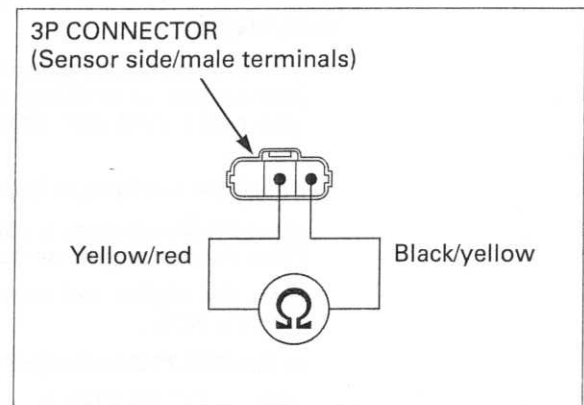

DTC 25-3 (KNOCK SENSOR LOW VOLTAGE)

- Before starting the inspection, check for loose or poor contact on the Knock sensor 3P (Black) connector and ECM 33P connectors, then recheck the DTC.

1. Knock Sensor System Inspection

Clear the DTC's (page 6-15).
Place the motorcycle on its sidestand.

Start the engine and recheck the Knock sensor with the HDS.

Is DTC 25-3 indicated?

YES – GO TO STEP 2.

NO – Intermittent failure

2. Knock Sensor Output Line Short Circuit Inspection 1

Turn the ignition switch OFF.

Disconnect the Knock sensor 3P (Black) connector.
Check for continuity between the Knock sensor 3P (Black) connector of the wire side and ground.

Connection: Blue – ground

Is there continuity?

YES – Short circuit in blue wire

NO – GO TO STEP 3.

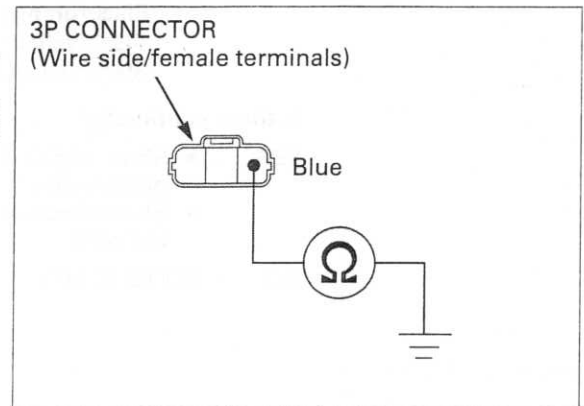

3. Knock Sensor Output Line Short Circuit Inspection 2

Check for continuity between the Knock sensor 3P (Black) connector of the sensor side and ground.

Connection: Blue – ground

Is there continuity?

YES – Faulty Knock sensor

NO – Replace the ECM with a known good one, and recheck

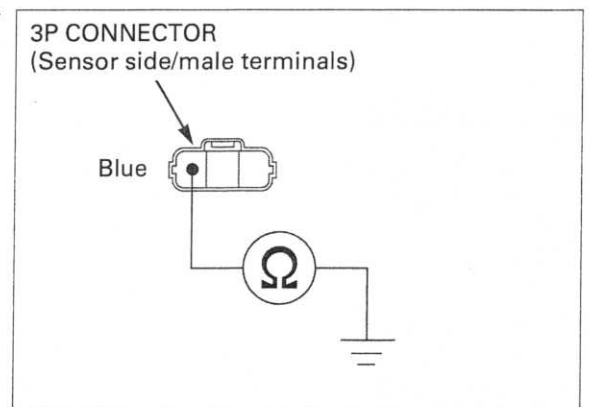

DTC 29-1 (IACV)

- Before starting the inspection, check for loose or poor contact on the IACV 4P (Black) connector and ECM 33P connectors, then recheck the DTC.

1. Recheck DTC

Clear the DTC's (page 6-15).
Start the engine and check the IACV with the HDS.

Is the DTC 29-1 indicated?

YES – GO TO STEP 2.

NO – Intermittent failure

2. IACV Short Circuit Inspection

Turn the ignition switch OFF.
Disconnect the IACV 4P (Black) connector.
Check for continuity between the IACV 4P (Black) connector at the wire side and ground.

Connection: **Black/blue – Ground**
Black/orange – Ground
Black/yellow – Ground
Black/red – Ground

Is there continuity?

- YES** –
- Short circuit in Black/blue or Black/orange wire
 - Short circuit in Black/yellow or Black/red wire

NO – GO TO STEP 3.

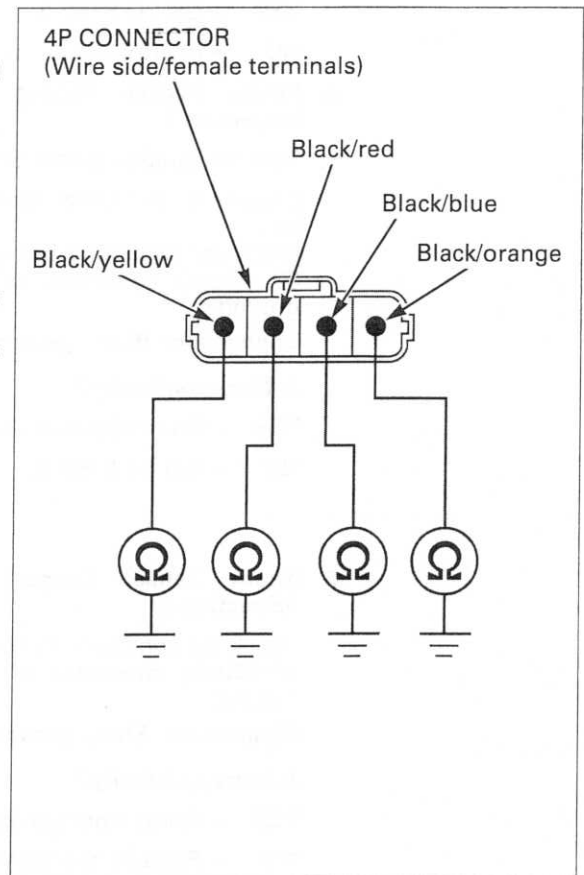

3. IACV Circuit Continuity Inspection

Disconnect the IACV 4P (Black) connector.
Check for continuity between the ECM 33P (Black) connector and IACV 4P (Black) connector.

- Connection:** A16 – Black/blue
A29 – Black/orange
A19 – Black/yellow
A27 – Black/red

TOOL:
Test probe 07ZAJ-RDJA110

Is there continuity?

YES – GO TO STEP 4.

- NO** –
- Open circuit in Black/blue or Black/orange wire
 - Open circuit in Black/yellow or Black/red wire

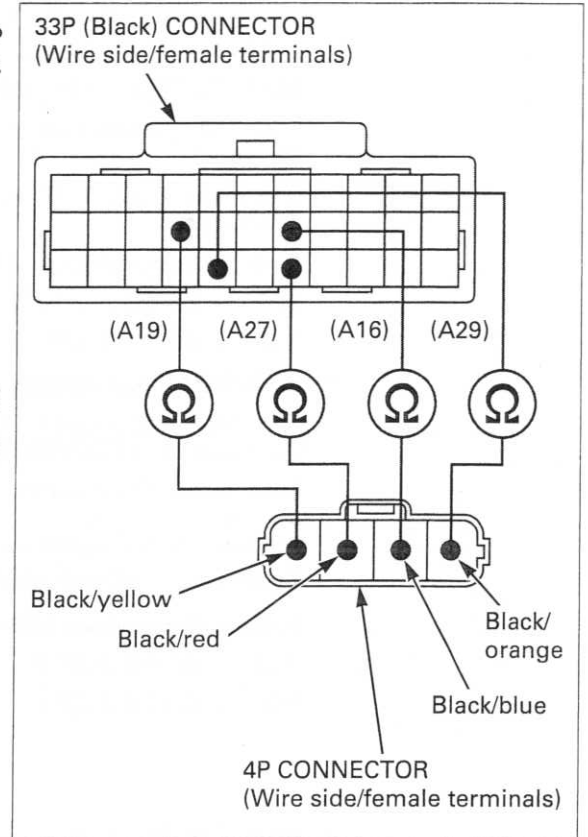

4. IACV Resistance Inspection

Measure the resistance at the IACV motor side.

- Connection:** Black/yellow – Black/orange
Black/red – Black/blue

Standard: 99 – 121 Ω (20°C/68°F)

Is the resistance within 99 – 121 Ω (20°C/68°F)?

YES – Replace the ECM with a known good one, and recheck

NO – Faulty IACV

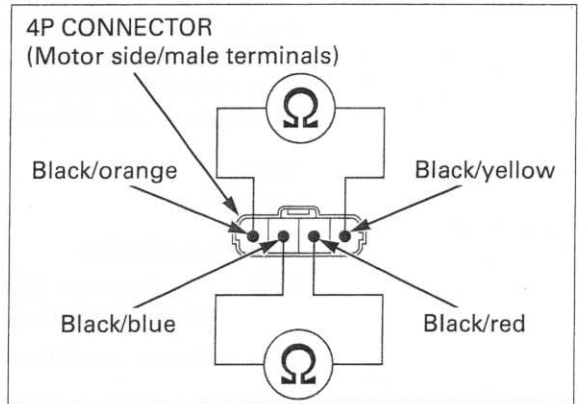

DTC 33-2 (EEPROM)

1. Recheck DTC

Clear the DTC's (page 6-15).
Turn the ignition switch ON and engine stop switch "O".
Recheck the ECM EEPROM.

Is the DTC 33-2 indicated?

YES – Replace the ECM with a known good one, and recheck

NO – Intermittent failure

DTC 34-1 (EGCV POT LOW VOLTAGE)

- Before starting the inspection, check for loose or poor contact on the EGCV 6P (Natural) connector and ECM 33P connectors, then recheck the DTC.

1. EGCV POT System Inspection

Turn the ignition switch ON and engine stop switch "O".

Check the EGCV POT with the HDS provided EGCV closed.

Is the indicated voltage within 2.0 – 2.1 V?

- YES** – Intermittent failure
- NO** – GO TO STEP 2.

2. EGCV POT Input Voltage Inspection

Turn the ignition switch OFF.
Disconnect the EGCV 6P (Natural) connector.

Turn the ignition switch ON and engine stop switch "O".
Measure the voltage at the wire side.

Connection: Yellow/red (+) – Gray/black (-)

Is the voltage within 4.75 – 5.25 V?

- YES** – GO TO STEP 4.
- NO** – GO TO STEP 3.

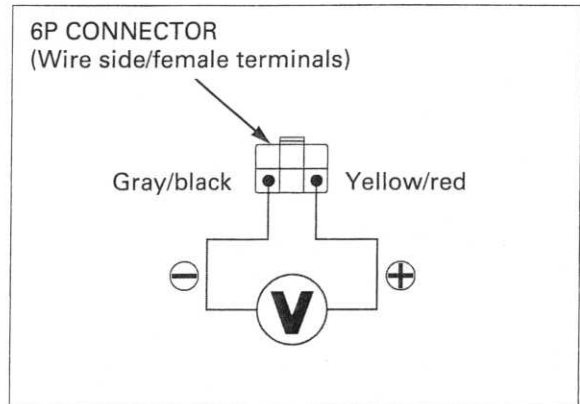

3. EGCV POT Circuit Inspection

Turn the ignition switch OFF.

Disconnect the ECM 33P (Black) connector.
Check for continuity between the EGCV 6P (Natural) connector and ECM 33P (Black) connector.

Connection: A9 – Yellow/red

TOOL:

Test probe **07ZAJ-RDJA110**

Is there continuity?

- YES** – Replace the ECM with a known good one, and recheck
- NO** – Open circuit in Yellow/red wire

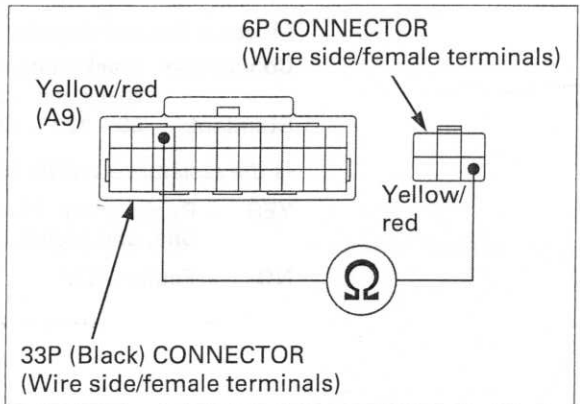

4. EGCV POT Output Line Open Circuit Inspection

Turn the ignition switch OFF.

Disconnect the ECM 33P (Gray) connector.
Check for continuity between the EGCV 6P (Natural) connector and ECM 33P (Gray) connector.

Connection: B18 – Light green/black

TOOL:

Test probe **07ZAJ-RDJA110**

Is there continuity?

- YES** – GO TO STEP 5.
- NO** – Open circuit in Light green/black wire

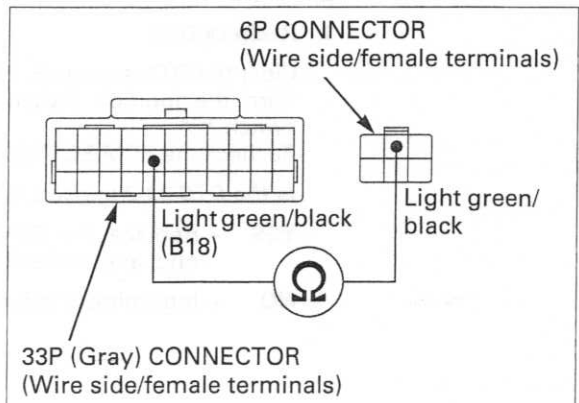

5. EGCV POT Output Line Short Circuit Inspection

Connect the ECM 33P connectors.

Check for continuity between the EGCV 6P (Natural) connector at the wire side and ground.

Connection: Light green/black – ground

Is there continuity?

- YES** – Short circuit in Light green/black wire
- NO** – GO TO STEP 6.

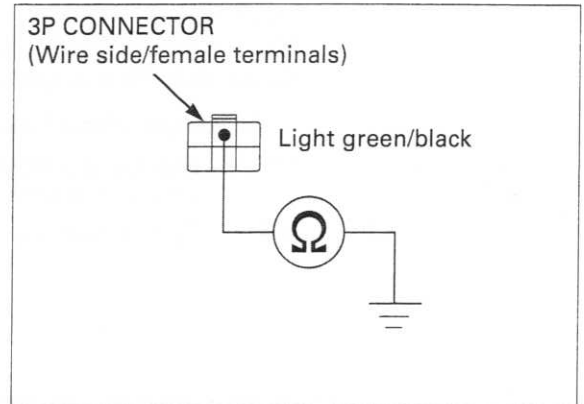

6. EGCV POT Inspection

Replace the EGCV servomotor with a known good one.

Clear the DTC's (page 6-15).

Turn the ignition switch ON and engine stop switch "O".

Check the EGCV POT with the HDS.

Is DTC 34-1 indicated?

- YES** – Replace the ECM with a known good one, and recheck
- NO** – Faulty original EGCV servomotor

DTC 34-2 (EGCV POT HIGH VOLTAGE)

- Before starting the inspection, check for loose or poor contact on the EGCV 6P (Natural) connector and ECM 33P connectors, then recheck the DTC.

1. EGCV POT System Inspection

Turn the ignition switch ON and engine stop switch "O".

Check the EGCV POT with the HDS.

Is about 5 V indicated?

- YES** – GO TO STEP 2.
- NO** –
 - Intermittent failure
 - Loose or poor contact on the EGCV 6P (Natural) connector

2. EGCV POT Resistance Inspection

Turn the ignition switch OFF.

Disconnect the EGCV 6P (Natural) connector. Measure the resistance at the EGCV POT side.

Connection: Yellow/red (+) – Green (-)

Is the resistance within 4.75 – 5.25 kΩ (20°C/ 68°F)?

- YES** – GO TO STEP 3.
- NO** – Faulty EGCV servomotor

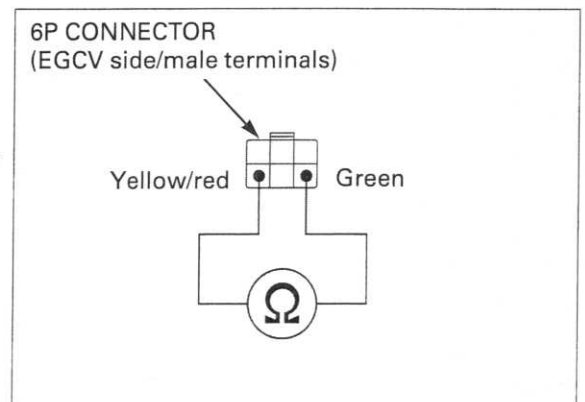

FUEL SYSTEM (PGM-FI)

3. EGCV POT Input Voltage Inspection

Turn the ignition switch ON and engine stop switch "O".

Measure the voltage at the wire side.

Connection: Yellow/red (+) – Gray/black (-)

Is the voltage within 4.75 – 5.25 V?

YES – Replace the ECM with a known good one, and recheck

NO – Open circuit in Gray/black wire

6P CONNECTOR
(Wire side/female terminals)

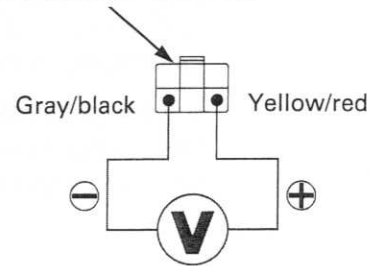

DTC 35-1 (EGCV SERVOMOTOR LOCK)

- Before starting the inspection, check for loose or poor contact on the EGCV 6P (Natural) connector and ECM 33P connectors, then recheck the MIL blinking.

1. EGCV Operating Inspection

Disconnect the EGCV control cables from the exhaust valve pulley (page 6-83).

Turn the ignition switch ON.

Check the EGCV servomotor pulley rotation when shorting the DLC (page 6-15).

Does the EGCV servomotor pulley operate correctly?

YES –

- Check the EGCV control cables binding, sticking or lock
- Check the EGCV at exhaust pipe side

NO – GO TO STEP 2.

2. EGCV Servomotor Inspection

Turn the ignition switch OFF.

Remove the EGCV servomotor (page 6-80).

Connect a 12 V battery to the EGCV 6P (Natural) connector terminals and check the servomotor function.

Connection: Red (+) – Blue (-)

Does the EGCV servomotor operate normally?

YES – GO TO STEP 3.

NO – Faulty EGCV servomotor

6P CONNECTOR
(Motor side/male terminals)

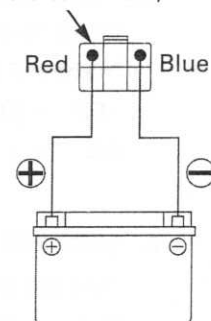

3. ECM Output Line Inspection

Disconnect the ECM 33P (Black) connector.
Check for continuity between the EGCV 6P (Natural) connector and ECM 33P (Black) connector.

Connection: Red – A10
Blue – A11

TOOL:

Test probe 07ZAJ-RDJA110

Is there continuity?

YES – Replace the ECM with a known good one, and recheck

NO – • Open circuit in Red wire
• Open circuit in Blue wire

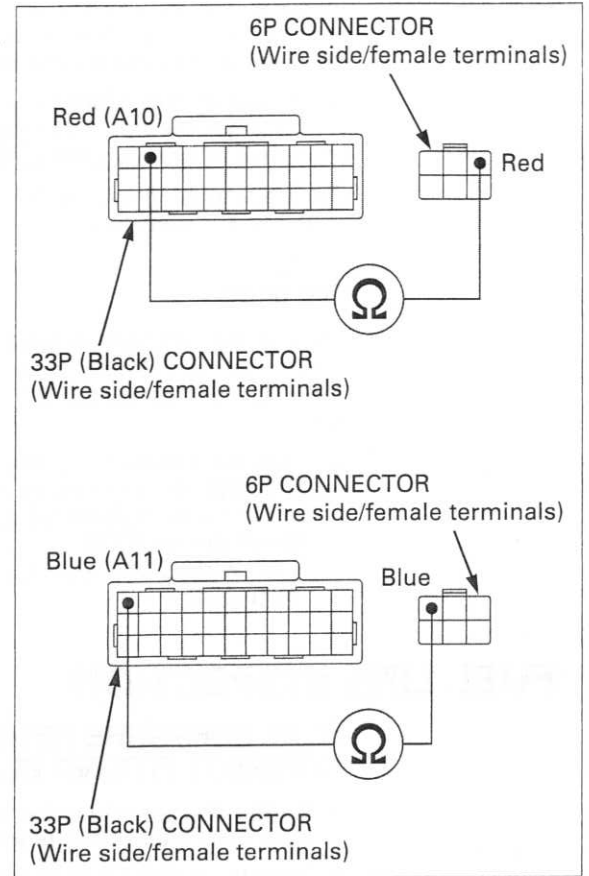

DTC 56-1 (KNOCK SENSOR IC)

1. Knock Sensor System Inspection

Clear the DTC's (page 6-15).
Place the motorcycle on its sidestand.

Start the engine and recheck the Knock sensor with the HDS.

Is about DTC 56-1 indicated?

YES – Replace the ECM with a known good one, and recheck

NO – Intermittent failure

MIL CIRCUIT TROUBLESHOOTING

If the engine can be started but the MIL does not come on when the ignition switch is ON and engine stop switch "O", check as follows:

- If they do not function, check the combination meter power input line (page 20-7).
- If they function properly, check as follows:

Turn the ignition switch OFF, disconnect the ECM 33P (black) connector.

TOOL:

Test probe

07ZAJ-RDJA110

Ground the White/blue wire terminal of the wire side connector with a jumper wire.

Turn the ignition switch ON, the MIL should come on.

- If the MIL comes on, replace the ECM.
- If the MIL does not come on, check for open circuit in the White/blue wire between the combination meter and ECM.
If the wire is OK, replace the combination meter (page 20-8).

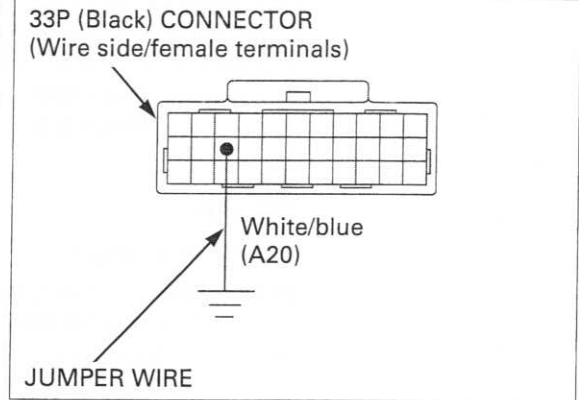

FUEL LINE INSPECTION

FUEL PRESSURE RELIEVING/QUICK CONNECT FITTING REMOVAL

- Before disconnecting the fuel hose, relieve pressure from the system as follows.
1. Turn the ignition switch OFF.
Lift and support the fuel tank (page 4-5).
 2. Disconnect the fuel pump 2P (Brown) connector.
 3. Start the engine, and let it idle until the engine stalls.
 4. Turn the ignition switch OFF.
 5. Disconnect the battery negative (-) cable (page 17-6).
 6. Check the fuel quick connect fitting for dirt, and clean if necessary.
Place a shop towel over the quick connect fitting.

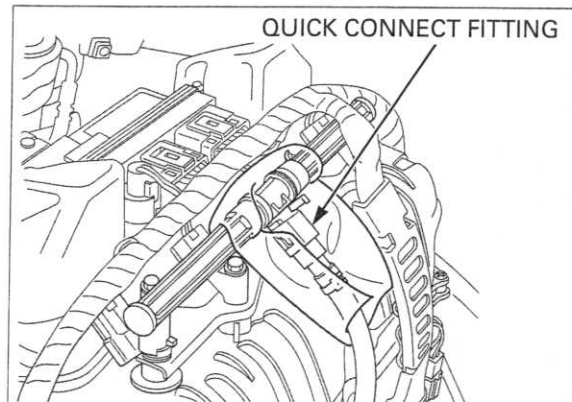
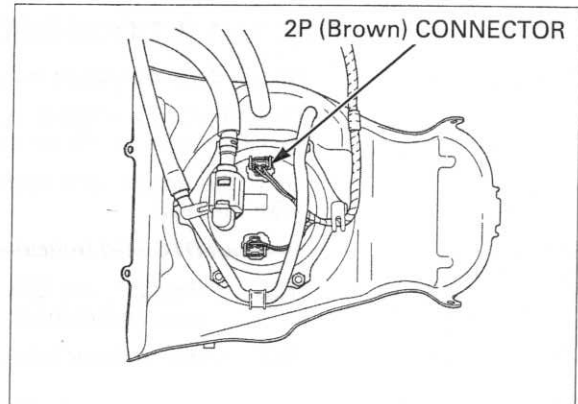

7. Pull and release the rubber cap from the retainer.
8. Hold the connector with one hand and squeeze the retainer tabs with the other hand to release them from the locking pawls. Pull the connector off, then remove the rubber cap and retainer from the fuel joint.
 - Absorb the remaining fuel in the fuel hose from flowing out with a shop towel.
 - Be careful not to damage the hose or other parts.
 - Do not use tools.
 - If the connector does not move, keep the retainer tabs pressed down, and alternately pull and push the connector until it comes off easily.
9. To prevent damage and keep foreign matter out, cover the disconnected connector and fuel joint with plastic bags.

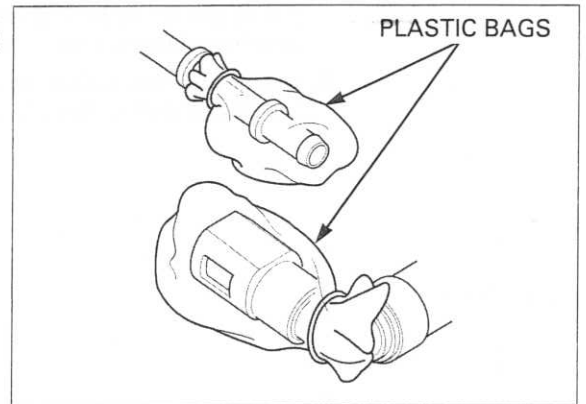
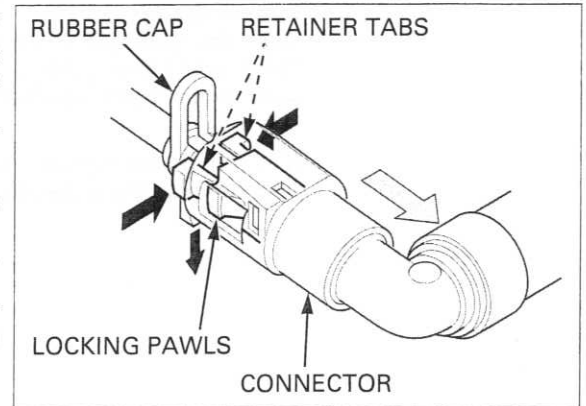

QUICK CONNECT FITTING INSTALLATION

- Always replace the retainer of the quick connect fitting when the fuel hose is disconnected.
 - If the rubber cap is damaged or cut, replace it with a new one.
 - Do not bend or twist the fuel hose.
 - If any retainer needs replacing, use the same manufacturer's retainer as the ones being removed (The various manufactures feature different retainer specification).
1. Insert a new retainer into the connector.
- Align new retainer locking pawls with the connector grooves.

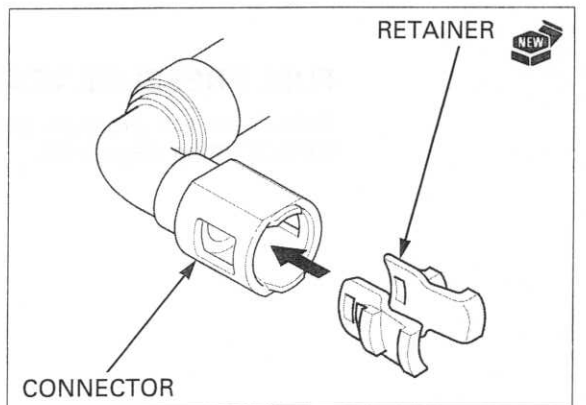

FUEL SYSTEM (PGM-FI)

2. Install the rubber cap and seat it onto the fuel joint as shown.
Align the quick connect fitting with the fuel joint. Then press the quick connect fitting onto the pipe until both retainer pawls lock with a "CLICK".

If it is hard to connect, put a small amount of engine oil on the pipe end.

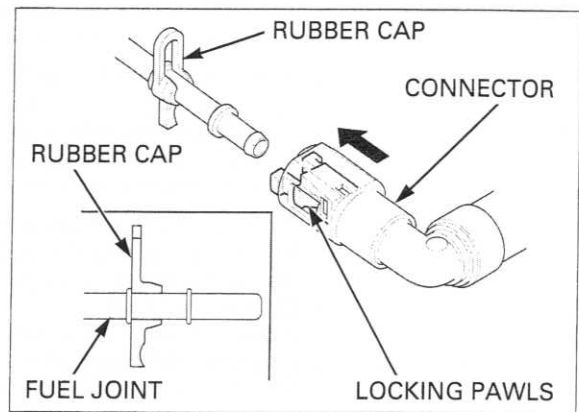

3. Make sure the connection is secure and that the pawls are firmly locked into place; check visually and by pulling the connector.
4. Make sure the rubber cap is in place (between the flange and retainer tab).

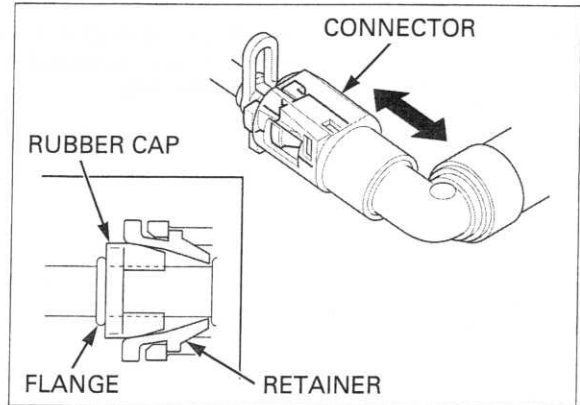

5. Connect the fuel pump 2P (Brown) connector.
6. Connect the battery negative (-) cable to the battery (page 17-6).
7. Turn the ignition switch ON and engine stop switch "O".

The fuel pump will run for about 2 seconds, and fuel pressure will rise.

Repeat 2 or 3 times, and check that there is no leakage in the fuel supply system.

Remove the suitable support and close the fuel tank (page 4-6).

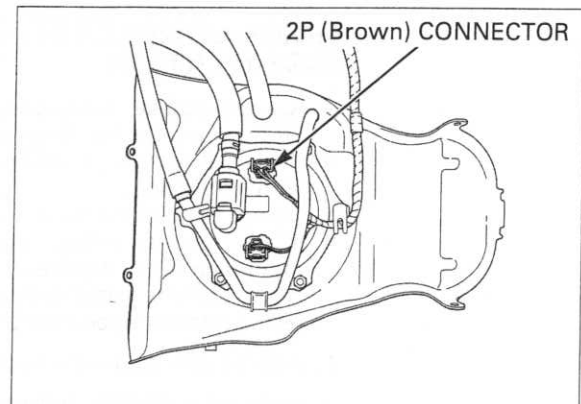

FUEL PRESSURE TEST

Relieve the fuel pressure and disconnect the quick connect fitting (page 6-42).

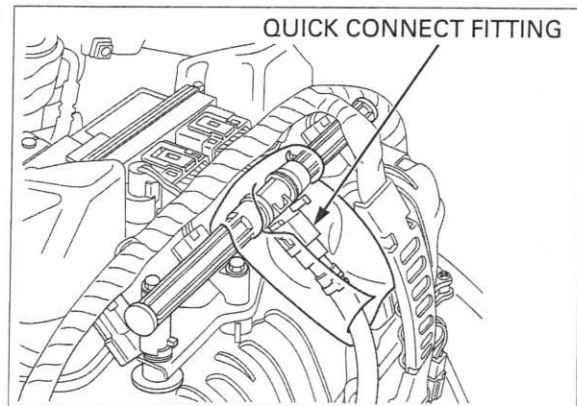

Attach the fuel pressure gauge, hoses, attachment joint and manifold.

TOOLS:

- | | |
|-------------------------------------|---------------|
| (1): Fuel pressure gauge | 07406-0040004 |
| (2): Pressure gauge manifold | 07ZAJ-S5A0111 |
| (3): Hose attachment,
9 mm/9 mm | 07ZAJ-S5A0120 |
| (4): Hose attachment,
8 mm/9 mm | 07ZAJ-S7C0100 |
| (5): Attachment joint,
8 mm/9 mm | 07ZAJ-S7C0200 |
- U.S.A. TOOLS:**
- | | |
|-----------------------------|-----------------------------------|
| (6): Fuel pressure gauge | 07406-004000B or
07406-004000A |
| (7): Pressure manifold hose | 07AMJ-HW3A100 |
| (8): Adaptor, male | 07AAJ-S6MA200 |
| (9): Adaptor, female | 07AAJ-S6MA400 |

Temporarily connect the battery negative (-) cable to the battery.
Connect the fuel pump 2P (Brown) connector.
Start the engine and let it idle.
Read the fuel pressure.

Standard: 343 kPa (3.5 kgf/cm², 50 psi)

If the fuel pressure is higher than specified, replace the fuel pump assembly (faulty fuel pump or fuel pressure regulator).

If the fuel pressure is lower than specified, inspect the following:

- Fuel line leaking
- Pinched or clogged fuel hose or fuel tank breather hose
- Fuel pump (page 6-47)
- Clogged fuel strainer screen (Assembly of the fuel pump: page 6-47)

Wrap a shop towel around the attachment to soak up any spilled fuel.

After inspection, relieve the fuel pressure by disconnecting the quick connect fitting (page 6-42).

Remove the fuel pressure gauge, hoses attachment joint and manifold.

Connect the quick connect fitting (page 6-43).

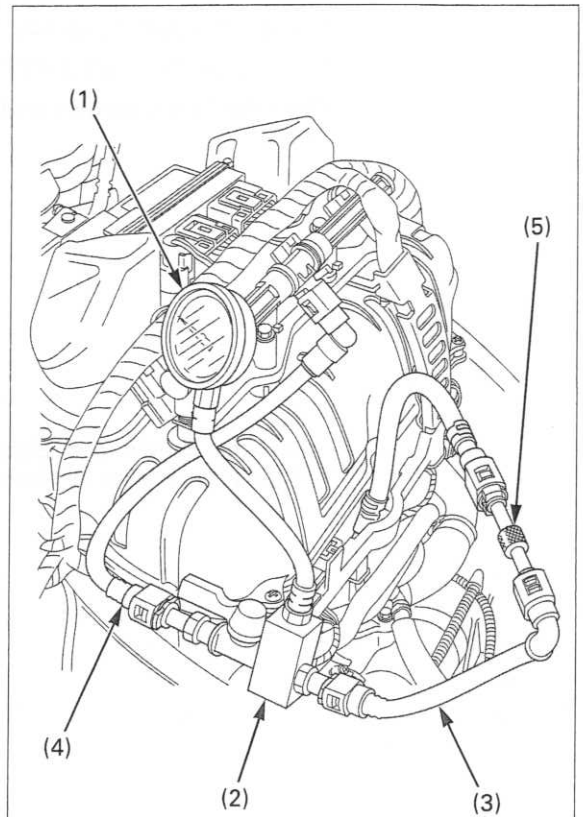

U.S.A. TOOLS:

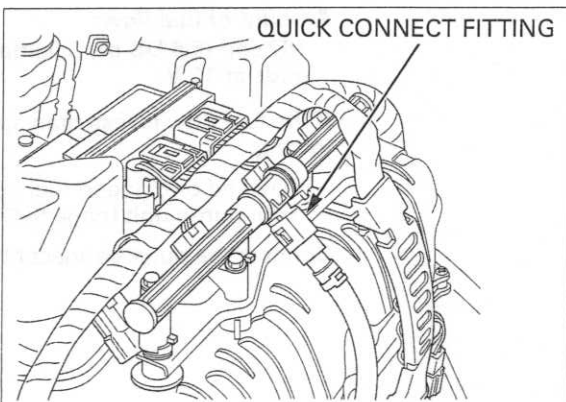
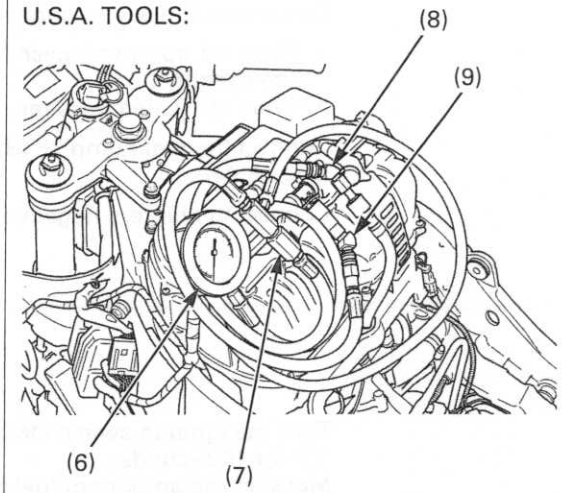

FUEL SYSTEM (PGM-FI)

FUEL FLOW INSPECTION

Remove the seat (page 3-4).

Turn the ignition switch OFF.

Open the fuse/relay box and remove the fuel pump relay.

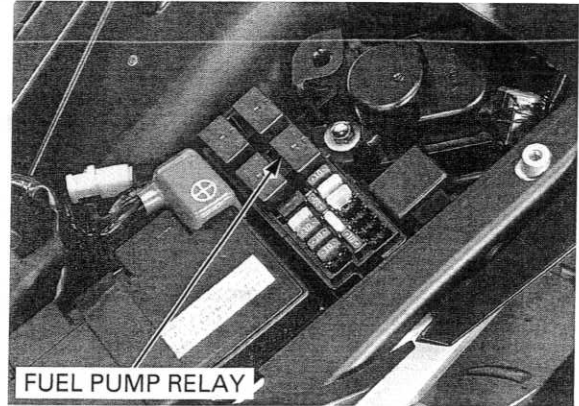

Jump the Brown and Black/white wire terminals using a jumper wire as shown.

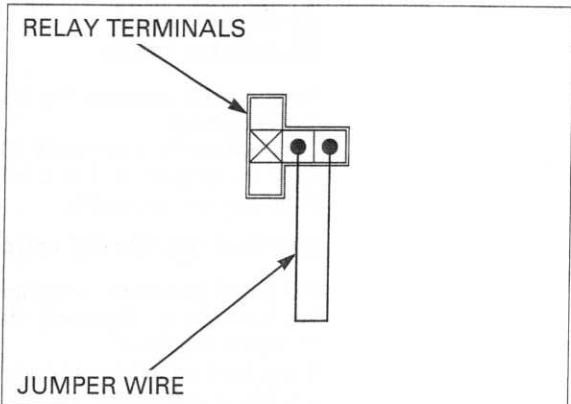

Disconnect the quick connect fitting (page 6-42).

- Place an approved gasoline container and drain the gasoline.
- Wipe off spilled gasoline.

Connect the fuel pump 2P (Brown) connector (page 6-44).

Connect the battery negative (-) cable (page 17-6).

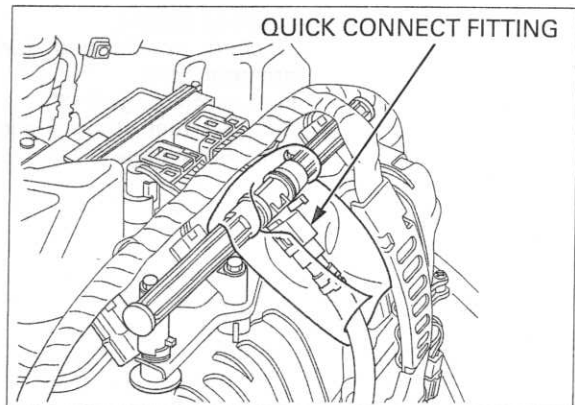

Turn the ignition switch ON and engine stop switch "O" for 10 seconds.

Measure the amount of fuel flow.

Amount of fuel flow:

167 cm³ (5.6 US oz, 5.9 Imp oz) minimum/10 seconds at 12 V

If the fuel flow is less than specified, inspect the following:

- Pinched or clogged fuel hose
- Fuel pump unit (page 6-47)

Connect the quick connect fitting (page 6-43).

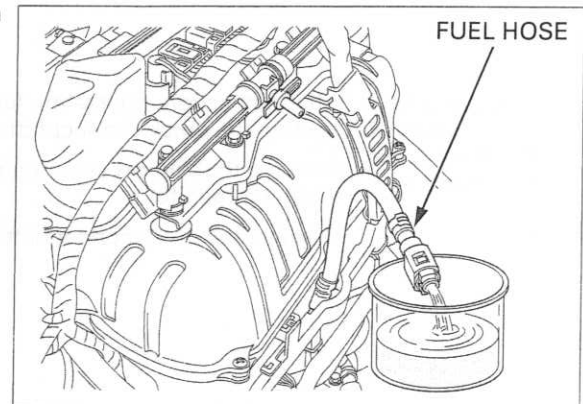

FUEL PUMP UNIT

INSPECTION

Turn the ignition switch ON and engine stop switch "O" then confirm that the fuel pump operates for a few seconds.

If the fuel pump does not operate, inspect as follows:

Turn the ignition switch OFF.

Lift and support the fuel tank (page 4-5).

Disconnect the fuel pump unit 2P (Brown) connector.

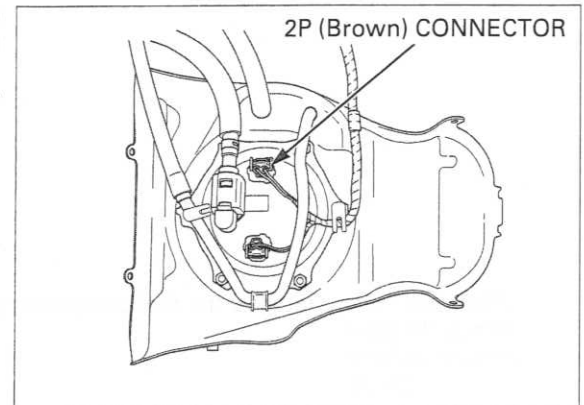

Turn the ignition switch ON and engine stop switch "O", measure the voltage between the terminals on the wire side.

Connection: Brown (+) – Green (-)

There should be battery voltage for a few seconds.

If there is battery voltage for a few seconds, replace the fuel pump unit.

If there is no battery voltage, inspect the following:

- Main fuse 30A
- Sub fuse (BANK ANGLE 10A)
- Sub fuse (FI 20A)
- Engine stop switch (page 20-18)
- Fuel pump relay (page 6-49)
- Engine stop relay (page 6-74)
- Bank angle sensor (page 6-72)
- ECM (page 6-75)

2P CONNECTOR
(Wire side/female terminals)

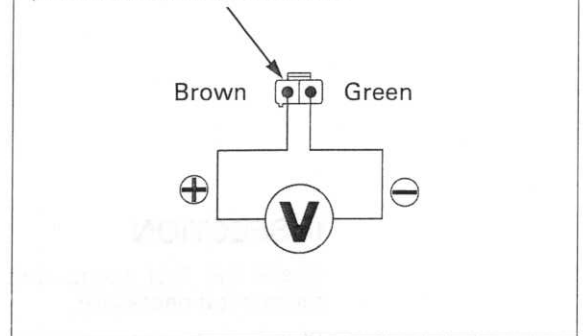

REMOVAL

Remove the fuel tank (page 6-50).

Disconnect the breather and drain hoses from the fuel tank.

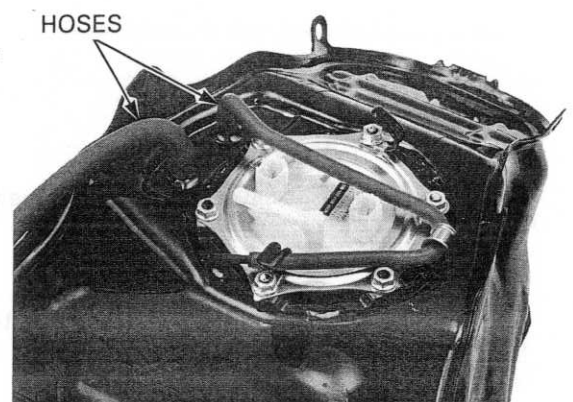

FUEL SYSTEM (PGM-FI)

Remove the fuel pump unit mounting nuts and clamps.

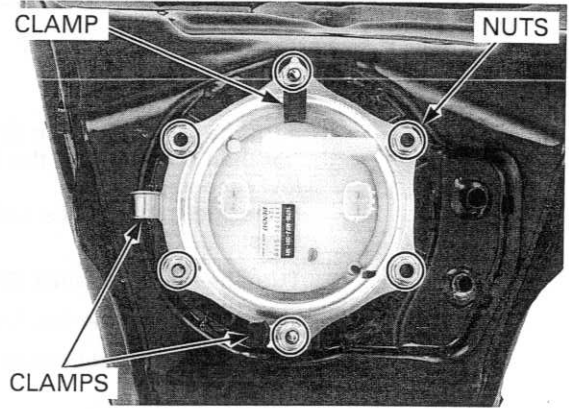

Be careful not to damage the pump wire and fuel level gauge.

Remove the fuel pump unit and packings.

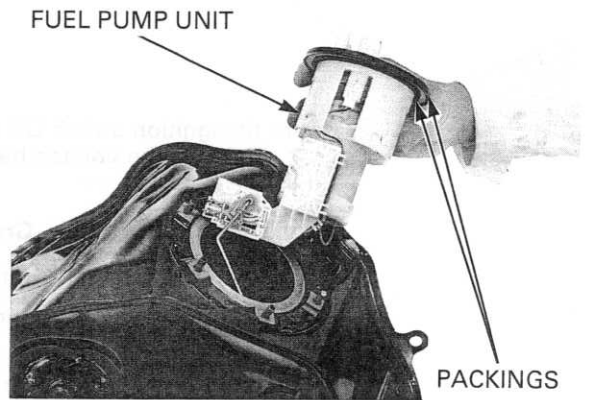

INSPECTION

Check the fuel pump unit for wear or damage, replace it if necessary.

Clean the fuel strainer screen with non-flammable or high flash point solvent.

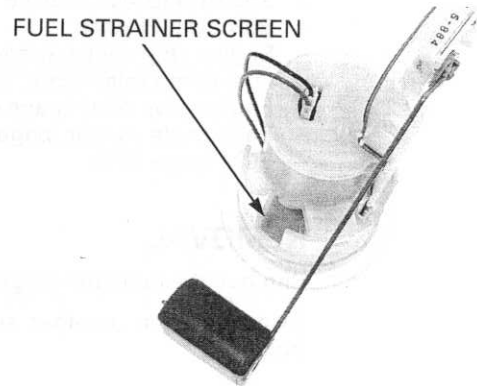

INSTALLATION

Always replace the packing with a new one.

Place new packings onto the fuel pump unit.

Be careful not to damage the pump wire and fuel level gauge.

Install the fuel pump unit to the fuel tank.



Install the clamps and tighten the fuel pump mounting nuts to the specified torque in the specified sequence as shown.

TORQUE: 12 N·m (1.2 kgf·m, 9 lbf·ft)

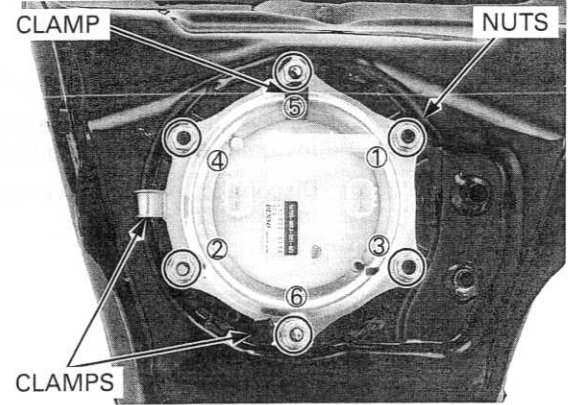

Route the hoses properly (page 1-21).

Connect the breather and drain hoses to the fuel tank securely.

Install the fuel tank (page 6-50).

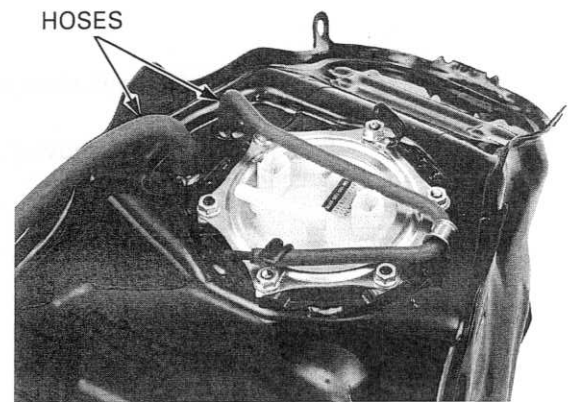

FUEL PUMP RELAY

INSPECTION

Remove the seat (page 3-4).

Open the fuse box and remove the fuel pump relay.

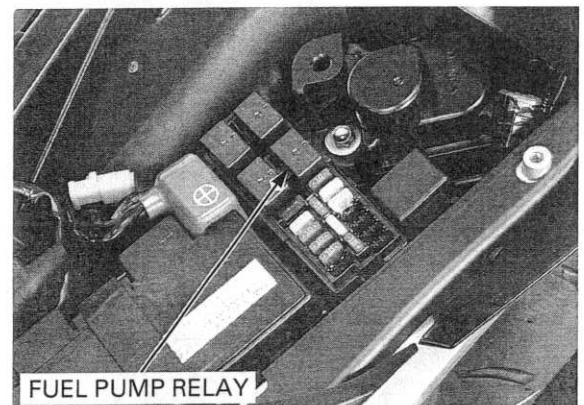

Connect the ohmmeter to the fuel pump relay terminals.

Connect a 12 V battery to the fuel pump relay terminals as shown.

There should be continuity only when the 12 V battery is connected. If there is no continuity when the 12 V battery is connected, replace the fuel pump relay.

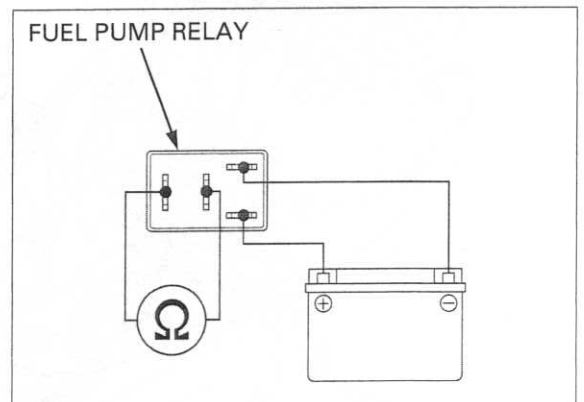

FUEL TANK

REMOVAL

Remove the quick connect fitting cover.

Relieve the fuel pressure (page 6-42) and disconnect the quick connect fitting from the fuel tank.

Disconnect the fuel level sensor 2P (Black) connector.

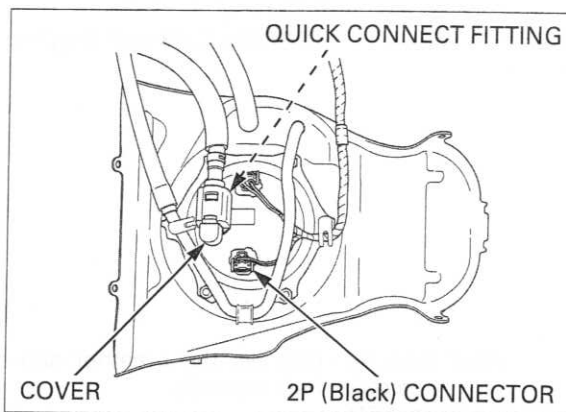

Remove the fuel tank pivot bolts, washers and fuel tank.

For fuel pump unit removal (page 6-47).

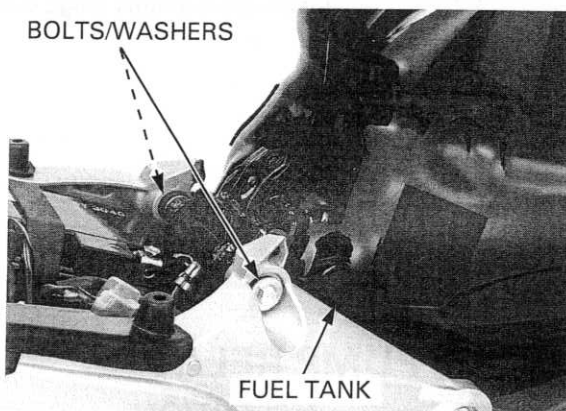

INSTALLATION

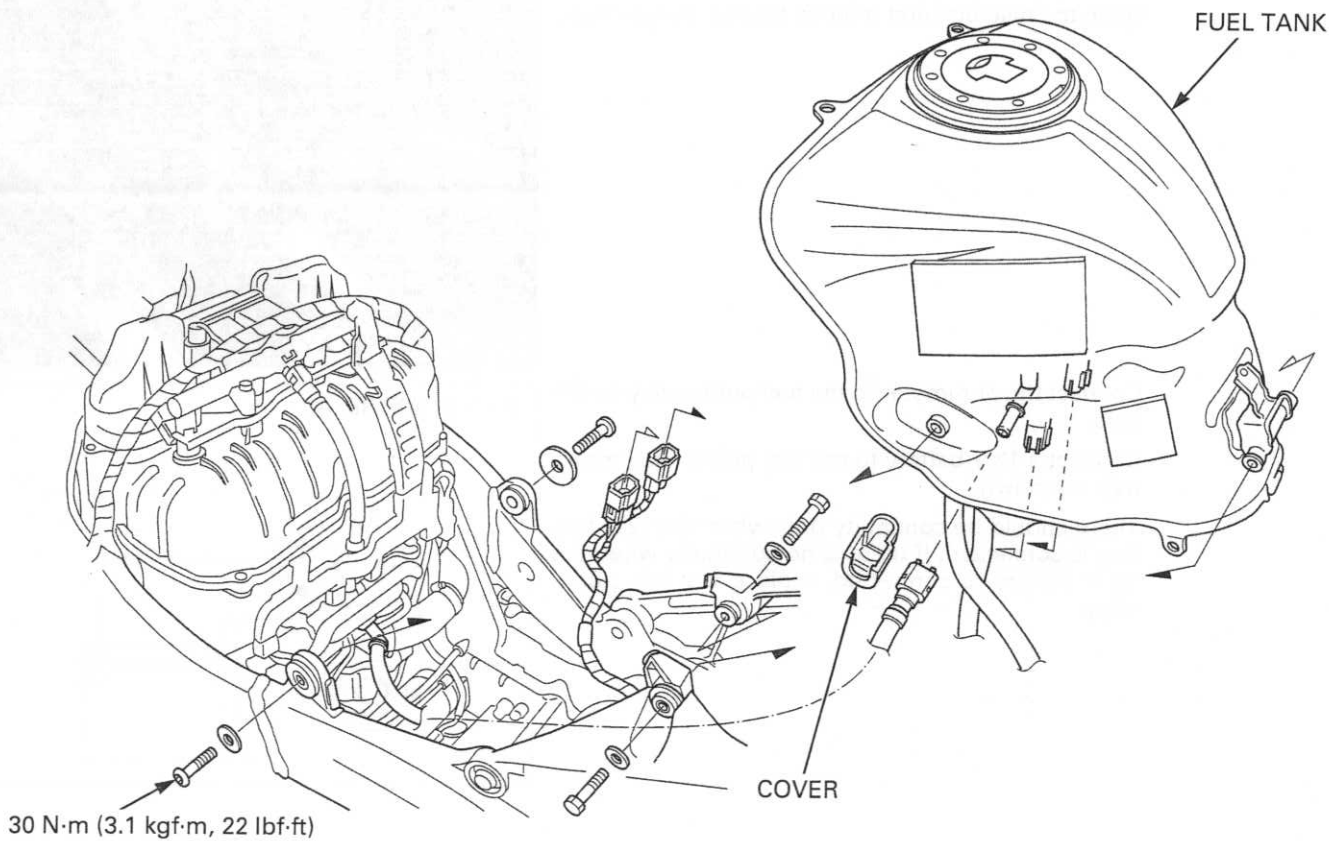

Install the fuel tank, washers and pivot bolts into the frame and tighten the bolts securely.
Support the fuel tank using a suitable support.

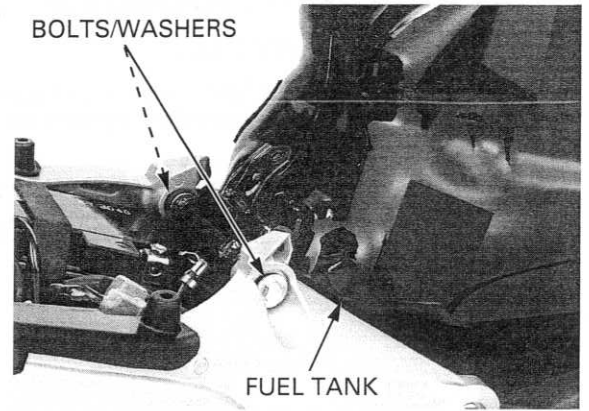

Route the hoses properly (page 1-21).

Connect the fuel level sensor 2P (Black) connector.
Connect the quick connect fitting (page 6-43).
Install the quick connect fitting cover securely.

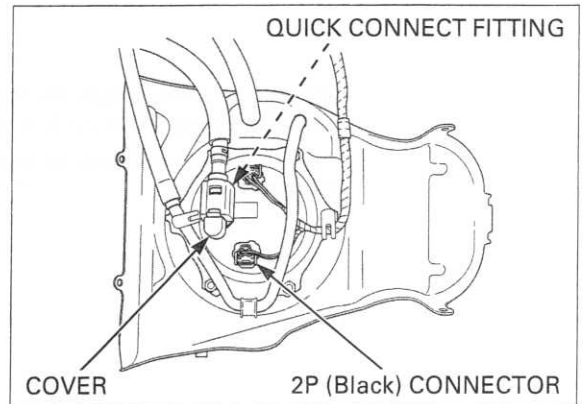

ENGINE GUARD RUBBER REMOVAL/INSTALLATION

Remove the fuel tank (page 6-50).
Remove the wire harness covers from the air cleaner housing.
Unhook the engine guard rubber from the wire harness guide then remove it.
Installation is in the reverse order of removal.

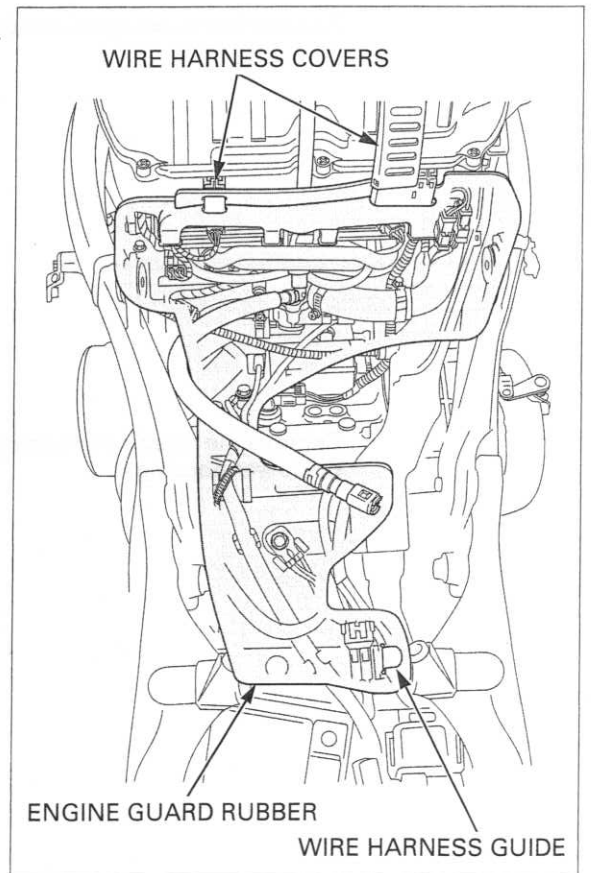

AIR CLEANER HOUSING

REMOVAL

- For MAP sensor removal/installation (page 6-70)
- For secondary injector removal/installation (page 6-57)

Remove the air cleaner element (page 4-8).

Disconnect the secondary injector 2P (Gray) connectors.

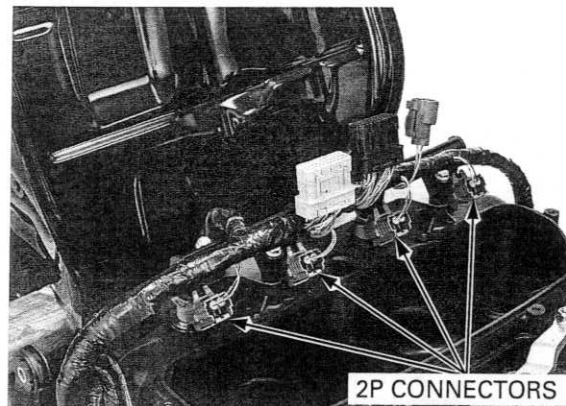

Relieve the fuel pressure and disconnect the quick connect fitting from the fuel rail joint (page 6-42).

Remove the wire harness cover from the air cleaner housing.

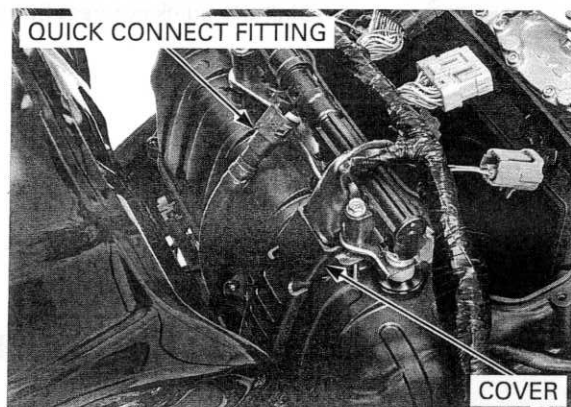

Remove the screws and middle housing.

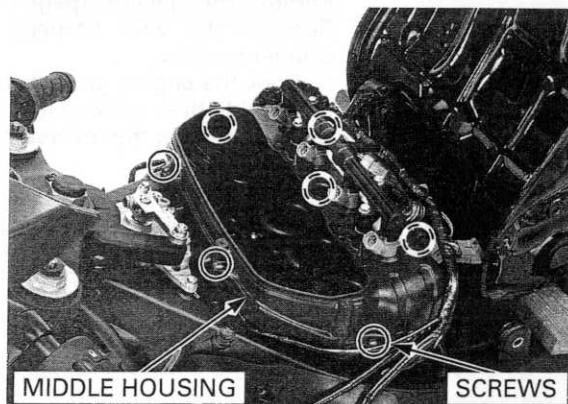

Remove the screws and remove the air funnels from the lower housing.

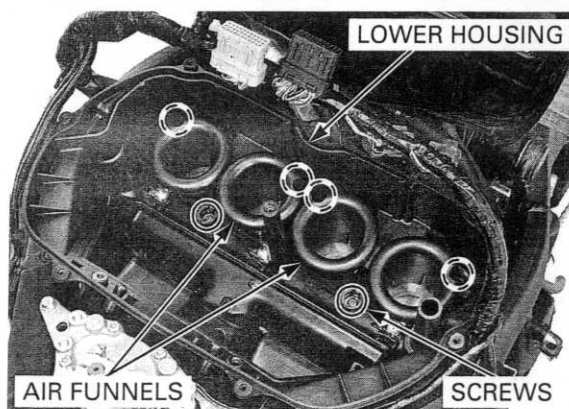

FUEL SYSTEM (PGM-FI)

Left side: Disconnect the PAIR air suction hose from the lower housing.

Right side: Disconnect the crankcase breather hose from the lower housing.

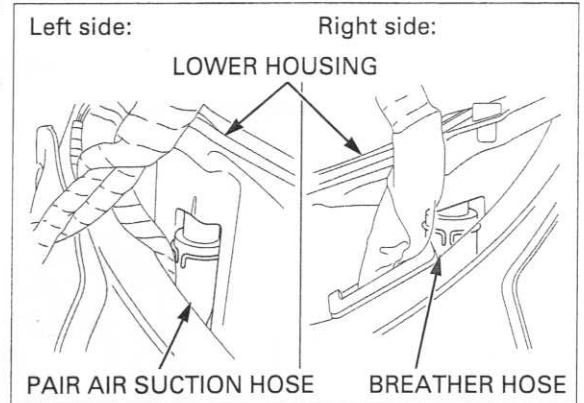

Disconnect the MAP sensor 3P (Black) connector and vacuum hose.

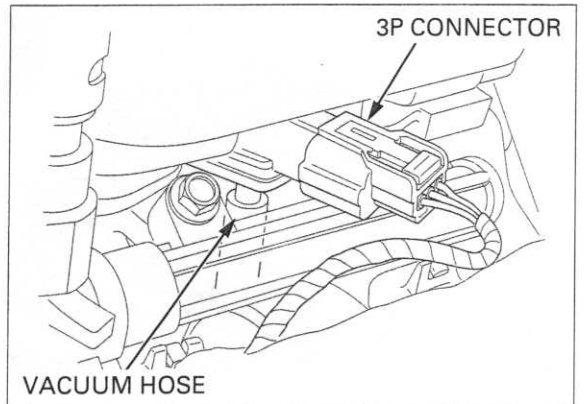

Be careful not to let dirt into the intake port. Be careful not to damage the lower housing at IACV contact area.

Remove the lower housing and air intake joint.

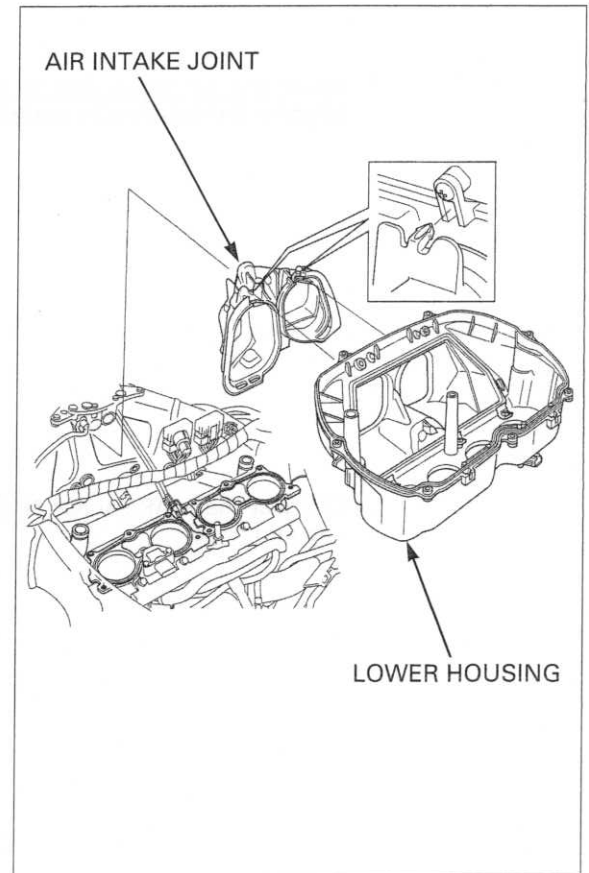

FUEL SYSTEM (PGM-FI)

INSTALLATION

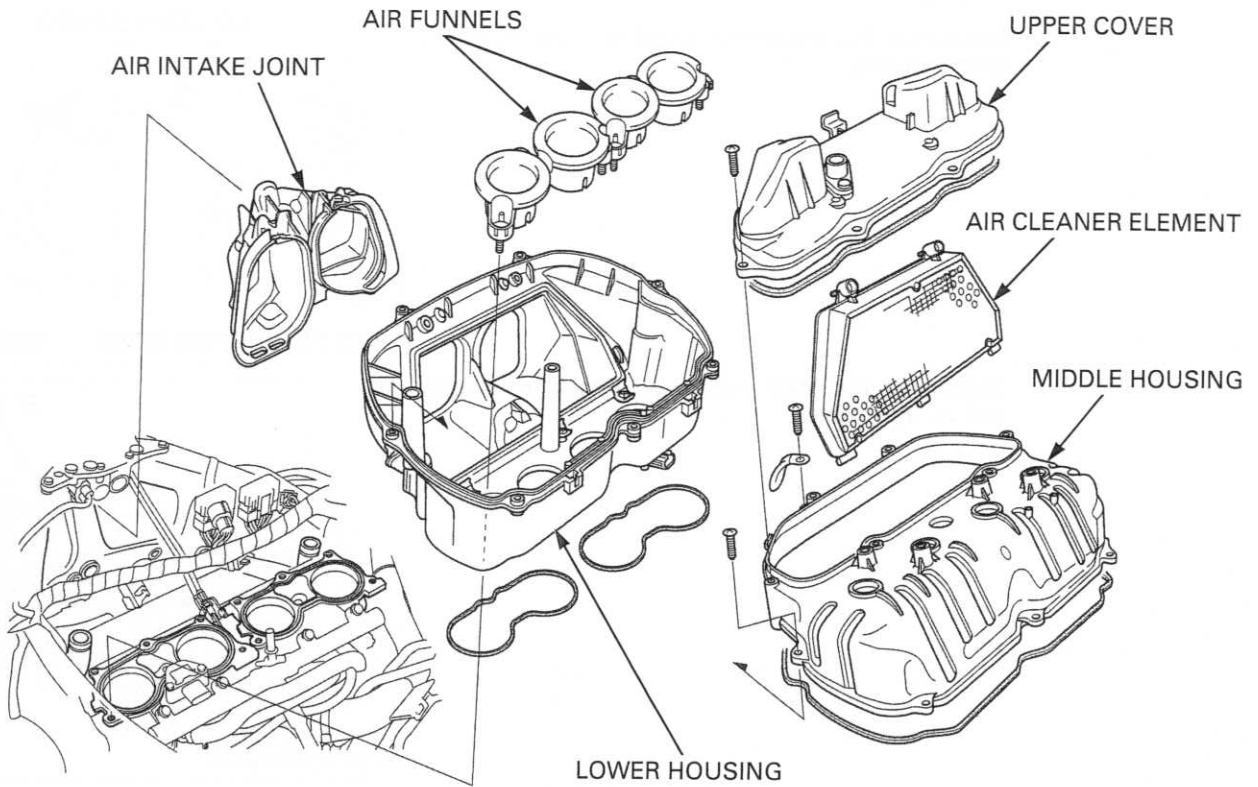

Install the air intake joint to the frame securely by aligning its bosses with the frame holes as shown.

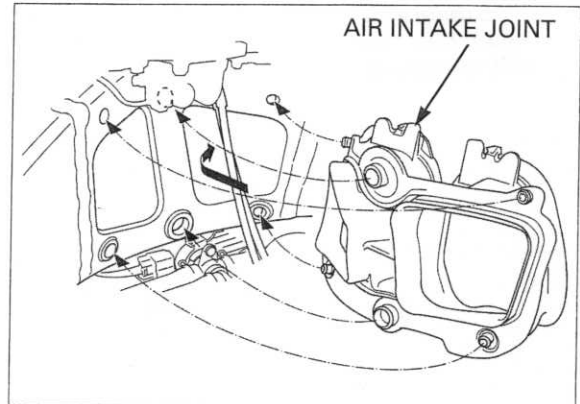

Connect the MAP sensor 3P (Black) connector and vacuum hose.

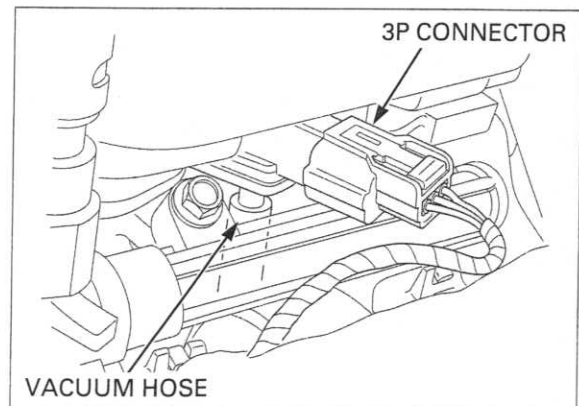

Right side: Connect the crankcase breather hose to the lower housing.

Left side: Connect the PAIR air suction hose to the lower housing.

Be careful not to let debris into the intake port. Install the lower housing onto the throttle body.

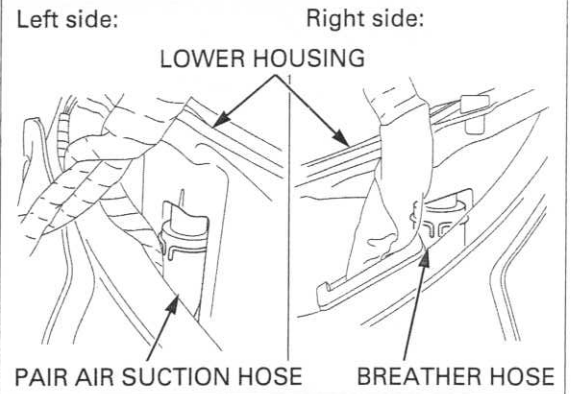

Set the lower housing to the air intake joint securely.

Push the lower housing forward against the air intake joint, then push it down onto the throttle body.

- Be careful not to damage the lower housing at IACV contact area.
- Align the air intake joint bosses with the lower housing grooves.

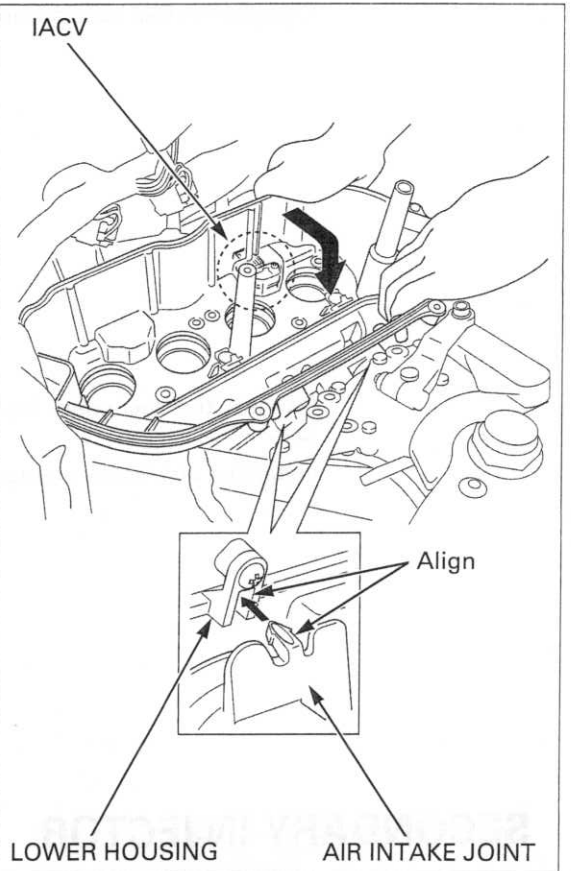

Install the air funnels onto the lower housing.

Install and tighten the air funnel/lower housing mounting screws to the specified torque.

TORQUE: 4.2 N·m (0.4 kgf·m, 3.1 lbf·ft)

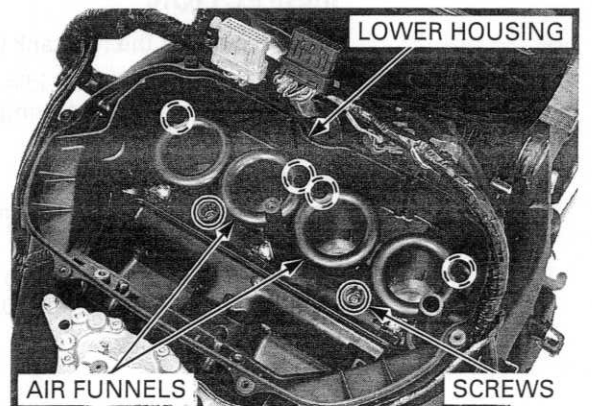

FUEL SYSTEM (PGM-FI)

Route the wires properly (page 1-21).
Install the middle housing and screws.
Tighten the screws securely.

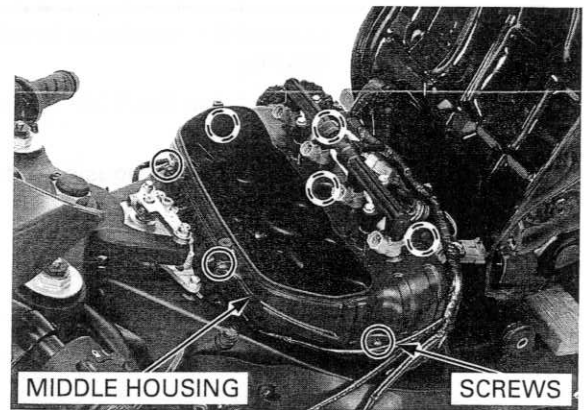

Install the wire harness cover securely.
Connect the fuel hose securely.

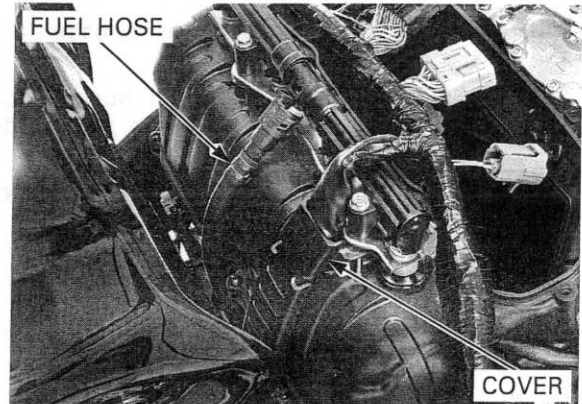

Connect the secondary injector 2P (Gray) connectors.

Install the air cleaner element (page 4-8).

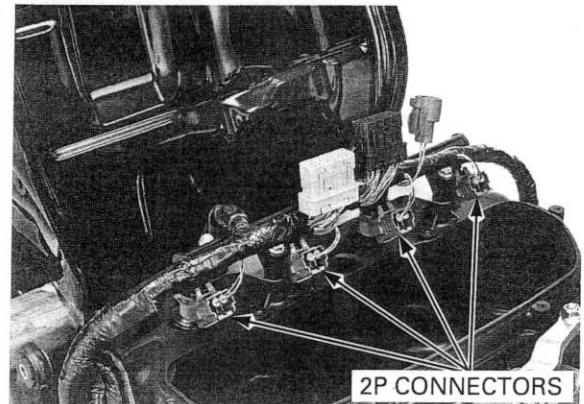

SECONDARY INJECTOR

INSPECTION

Lift and support the fuel tank (page 4-5).

Start the engine and let it idle.

Confirm the injector operating sounds with a sounding rod or stethoscope.

NOTE:

The secondary injectors operate with following conditions.

- Engine speed is over 4,400 rpm
- Throttle opening is over 10°

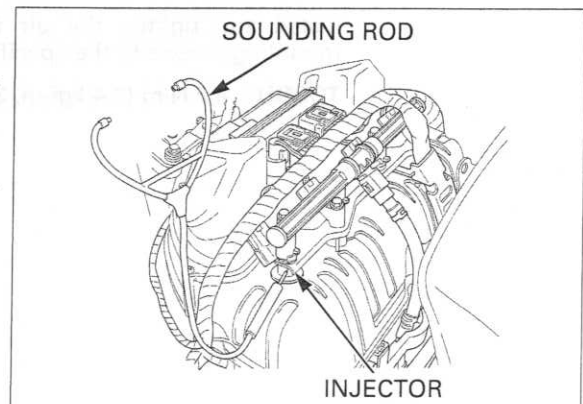

REMOVAL

Remove the air cleaner cover (page 4-8).

Disconnect the secondary injector 2P (Gray) connectors.

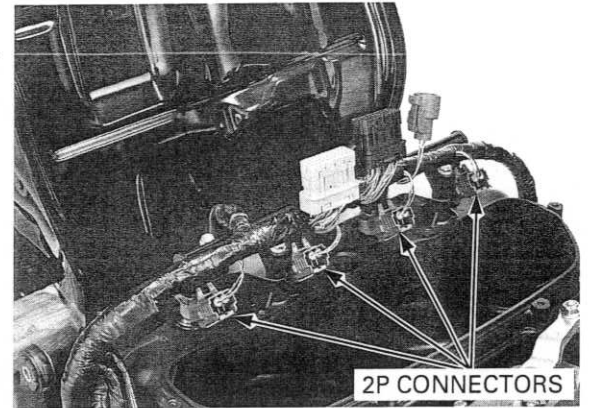

Relieve the fuel pressure and disconnect the quick connect fitting from the fuel rail joint (page 6-42).

Remove the wire harness cover.

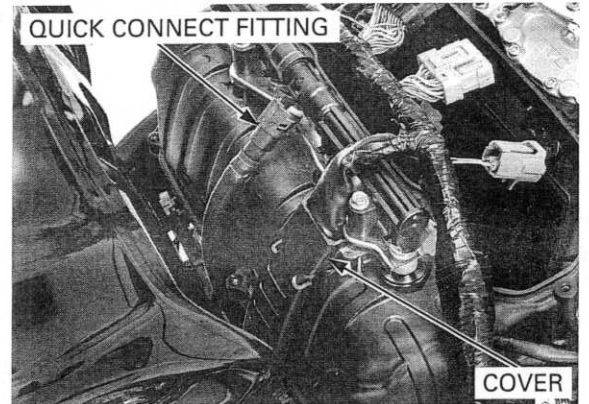

Remove the bolts and fuel rail assembly from the air cleaner housing.

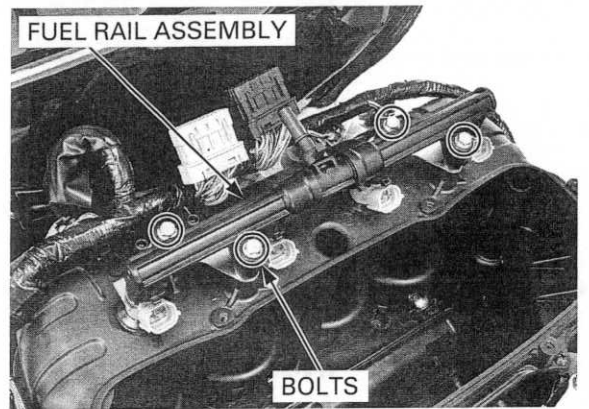

Remove the injector plate from the fuel rail.

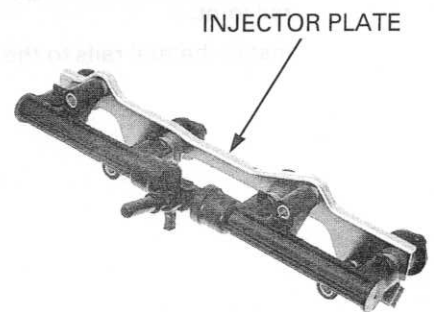

FUEL SYSTEM (PGM-FI)

Remove the injectors from the fuel rail.

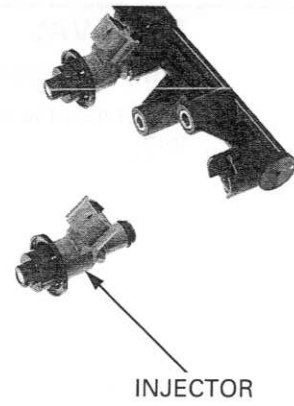

Remove the O-ring and seal ring.

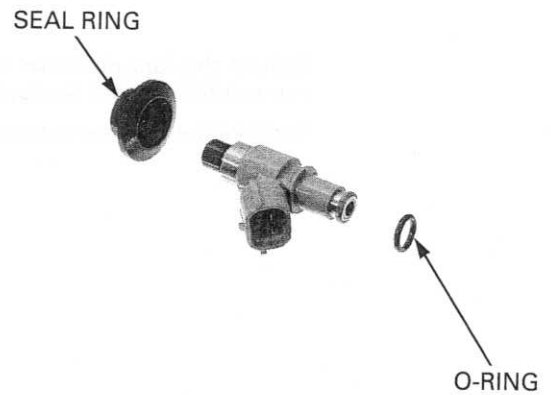

Remove the fuel rails and O-rings from the fuel rail joint.

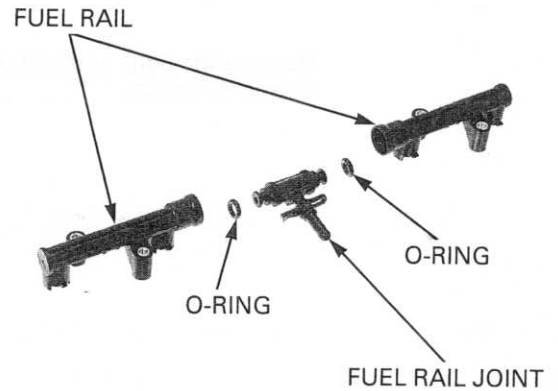

INSTALLATION

Apply oil to new O-rings and install them to the fuel rail joint.

Install the fuel rails to the fuel rail joint.

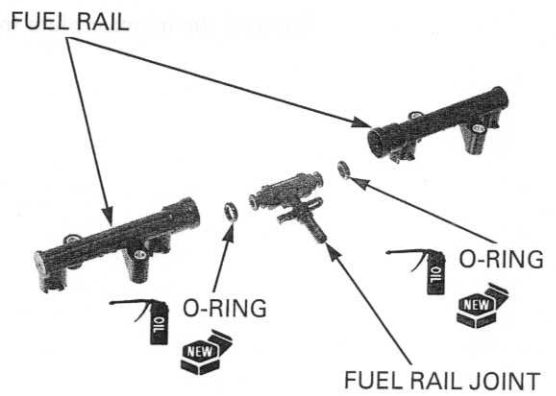

Apply oil to a new O-ring and install it to the injector, being careful not to damage the O-ring.

Replace the dust seal and O-ring with new ones as a set.

Install a new seal ring to the injector.

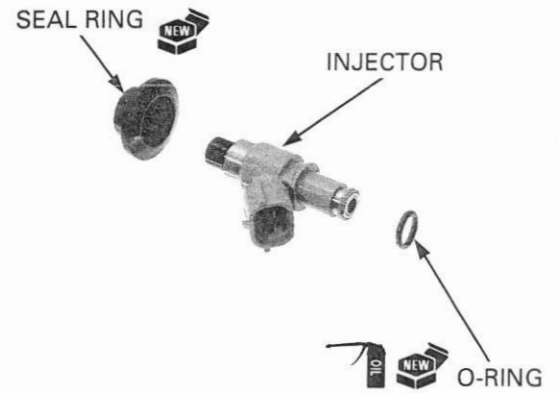

Install the injectors to the fuel rail, being careful not to damage the O-rings.



Install the injector plate to the fuel rail assembly.

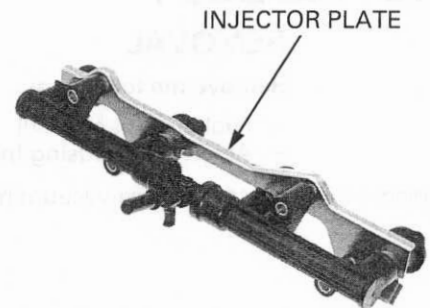

Install the fuel rail assembly onto the air cleaner housing and tighten the bolts to the specified torque.

TORQUE: 5.3 N·m (0.5 kgf·m, 3.9 lbf·ft)

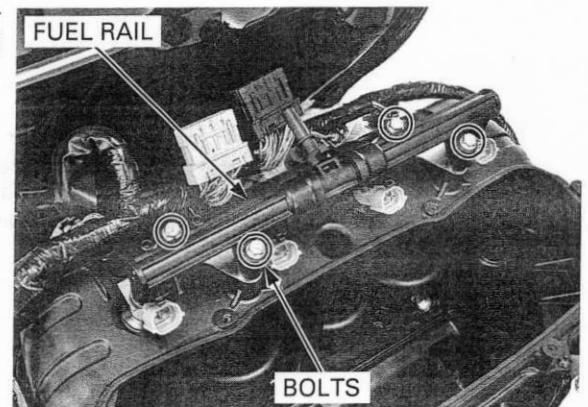

FUEL SYSTEM (PGM-FI)

Connect the quick connect fitting (page 6-43).
Install the wire harness cover securely.

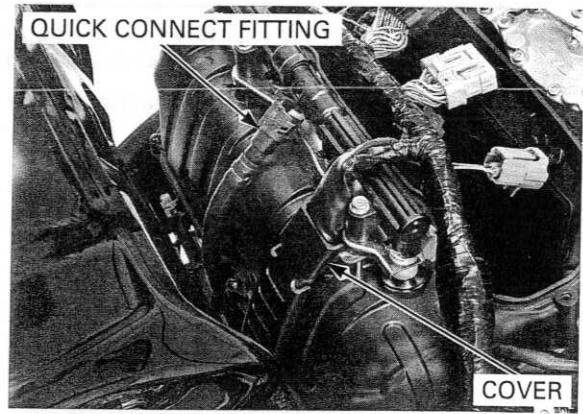

Connect the secondary injector 2P (Gray) connectors.

Install the air cleaner cover (page 4-8).

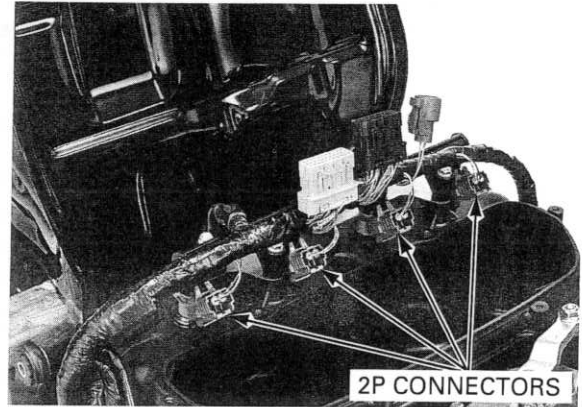

THROTTLE BODY

REMOVAL

Remove the following:

- Fuel tank (page 6-50)
- Air cleaner housing (page 6-52)

California type: Disconnect the vacuum hose from the 5-way joint.

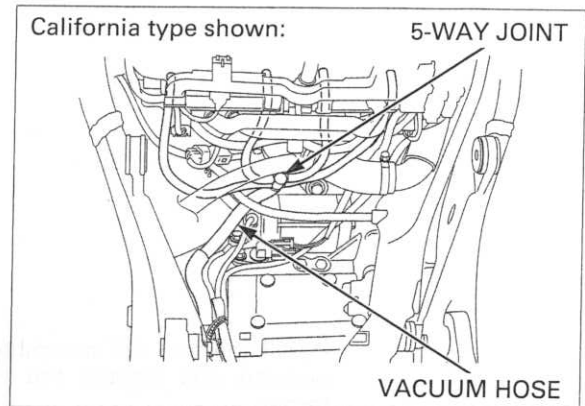

Disconnect the following:

- IACV 4P (Black) connector
- TP sensor 3P (Black) connector
- Knock sensor 3P (Black) connector
- Primary injector 2P (Gray) connectors

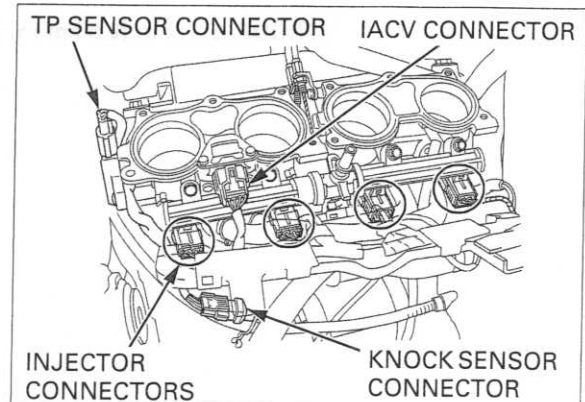

Loosen the insulator band screws using a long type phillips screwdriver.

Do not hold the fuel rail on the throttle body to remove the throttle body, or it may be damaged.

Remove the throttle body from the cylinder head.

THROTTLE BODY

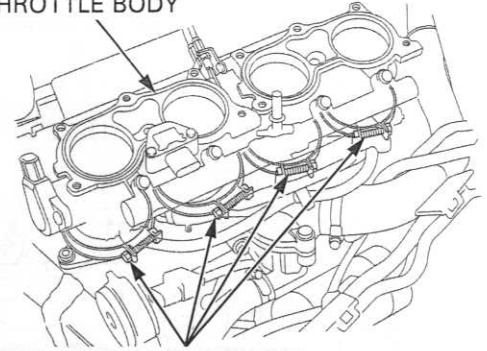

INSULATOR BAND SCREWS

Do not snap the throttle valve from fully open to fully closed after the throttle cable has been removed. It may cause incorrect idle operation.

Loosen the lock nut, adjusting nuts and disconnect the throttle cables from the throttle drum.

- Seal the cylinder head intake ports with tape or a clean cloth to keep dirt and debris from entering the intake ports after the throttle body has been removed. If debris is allowed to enter the ports the engine may be damaged.
- The throttle body is factory pre-set. Do not disassemble in a way other than shown in this manual.
- Do not loosen or tighten the white painted bolts and screws of the throttle body. Loosening or tightening them can cause throttle valve and idle control failure.

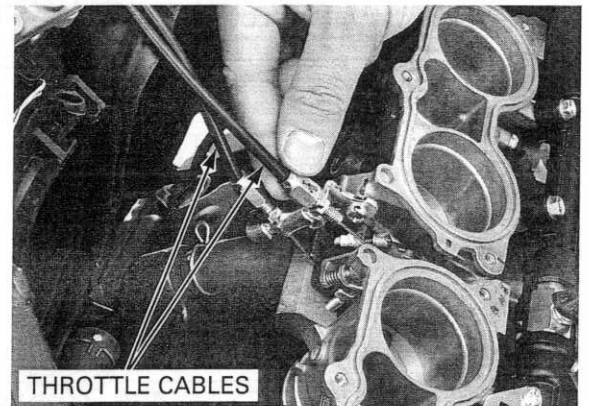

THROTTLE CABLES

PAINTED WHITE

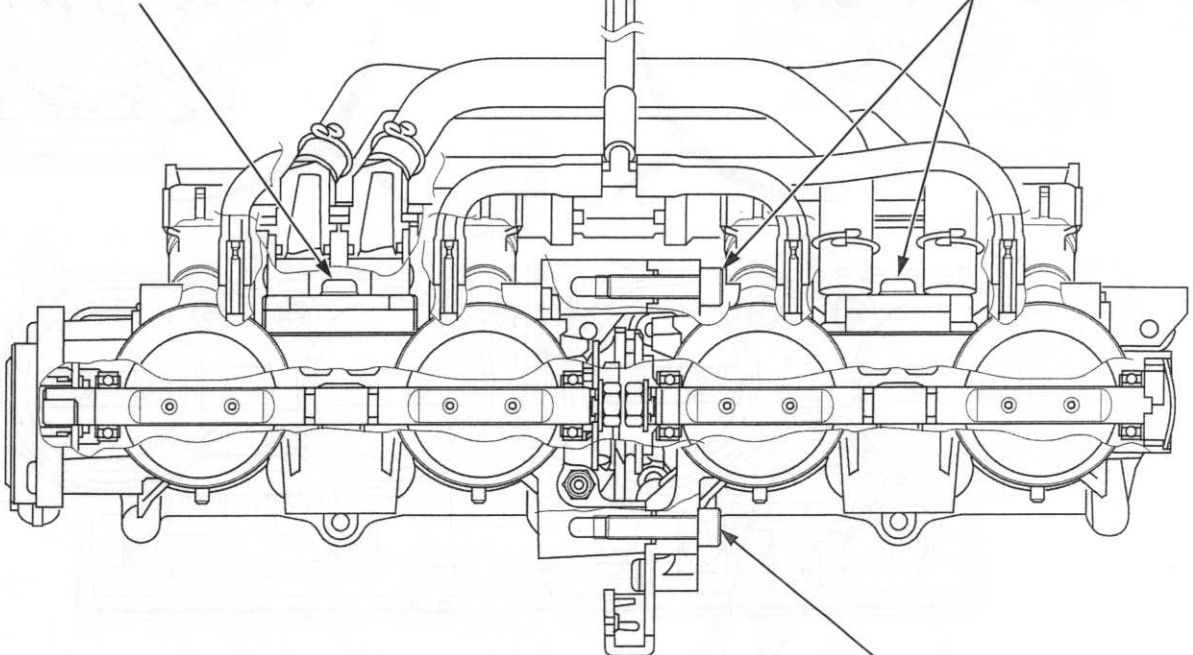

PAINTED WHITE

PAINTED WHITE

FUEL SYSTEM (PGM-FI)

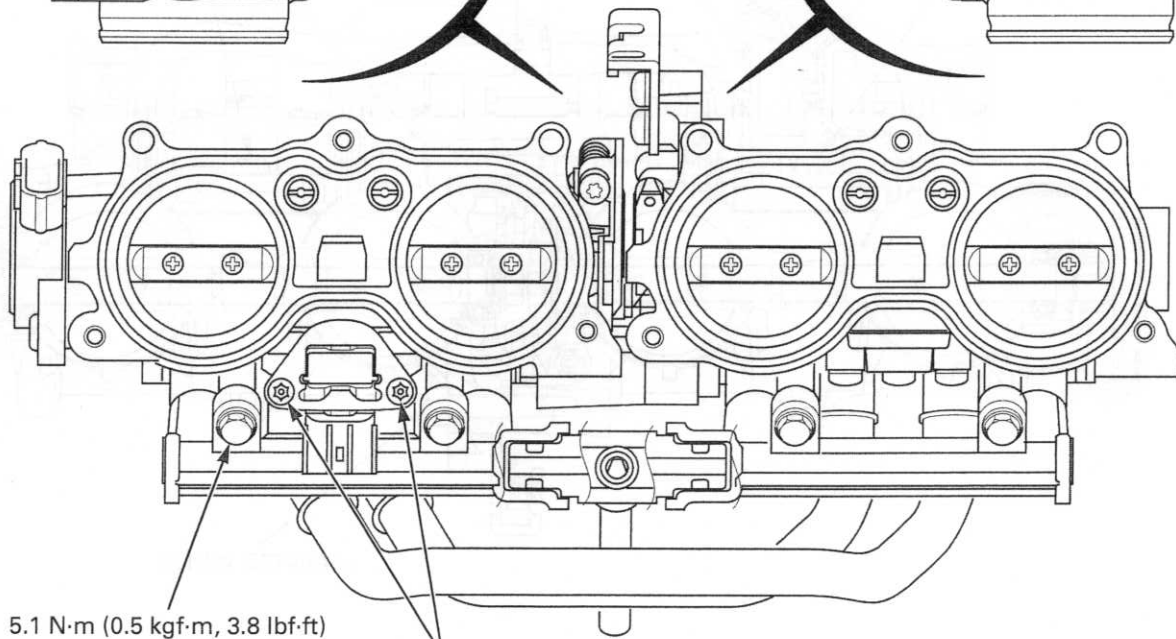
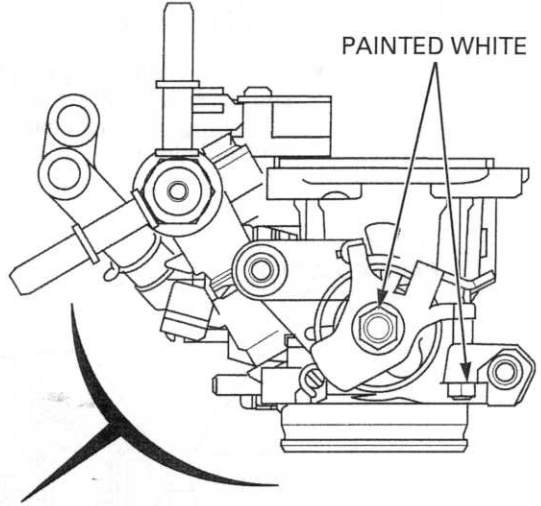
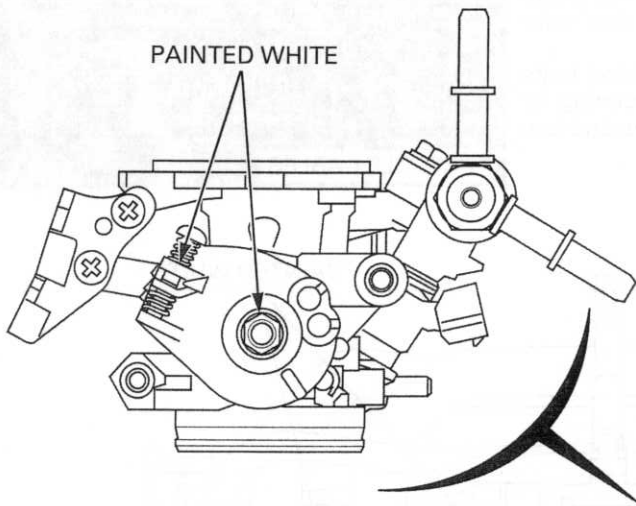
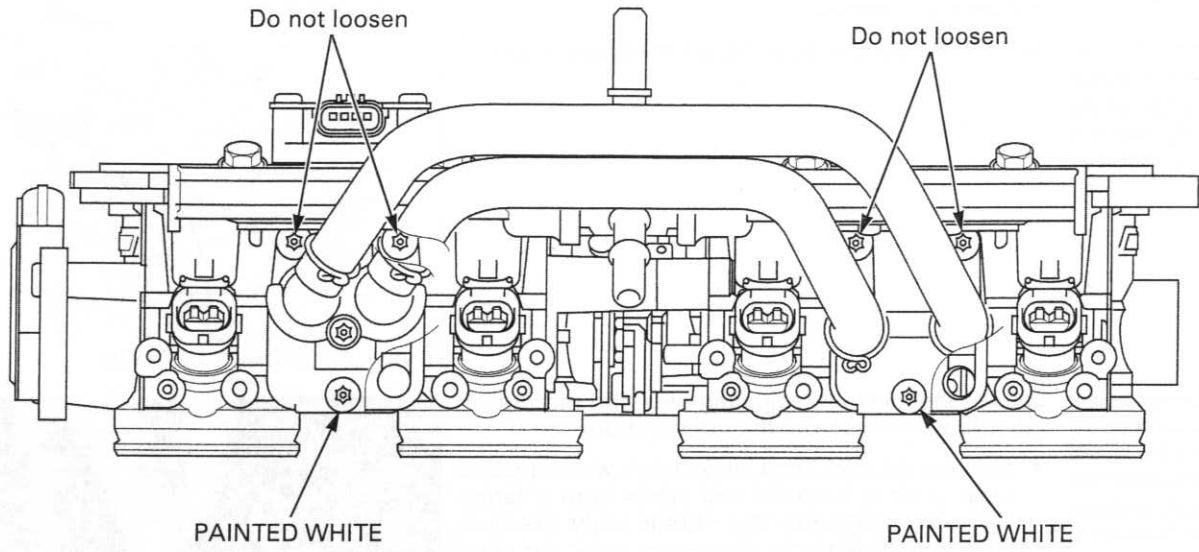

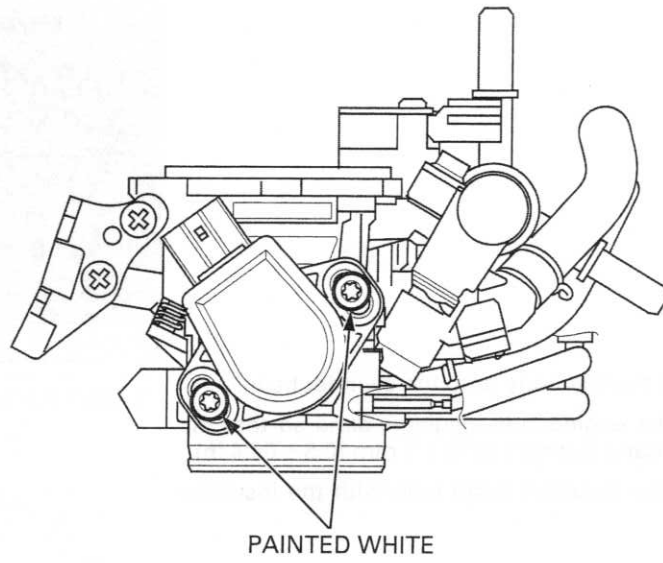

THROTTLE BODY VACUUM HOSE ROUTING (CALIFORNIA TYPE)

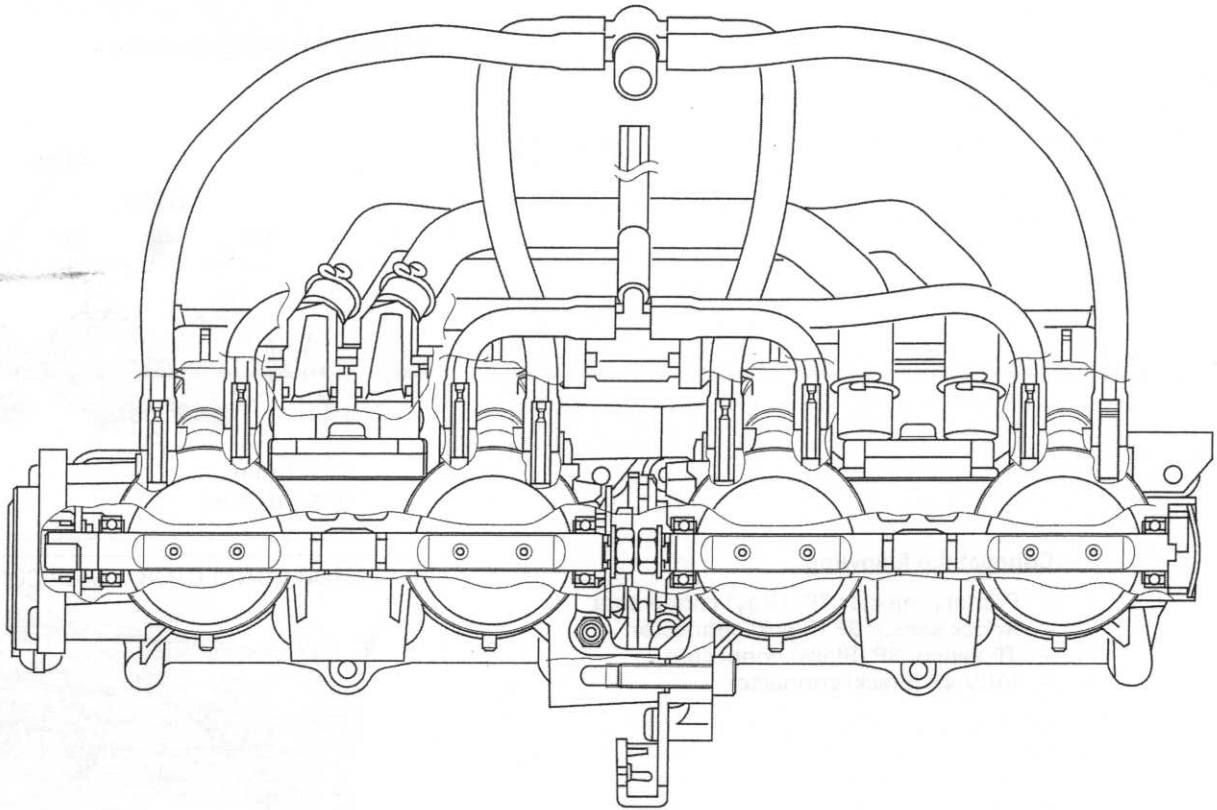

FUEL SYSTEM (PGM-FI)

INSTALLATION

Route the throttle cables properly (page 1-21). Connect the throttle cable ends to the throttle drum.

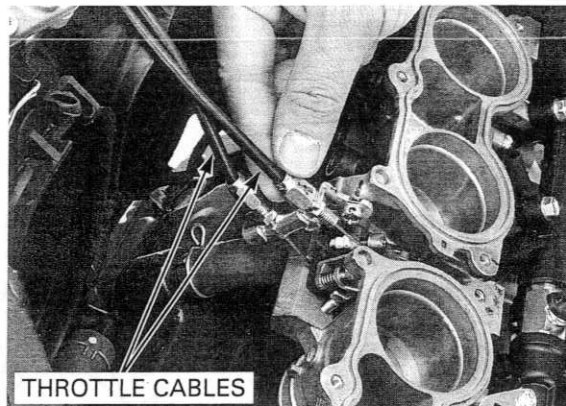

Do not hold the fuel rail on the throttle body to install the throttle body. Install the throttle body onto the cylinder head.

Tighten the engine side insulator band so that the insulator band distance is 12 ± 1 mm (0.5 ± 0.04 in).

- Align the insulator band hole with the insulator boss.

THROTTLE BODY

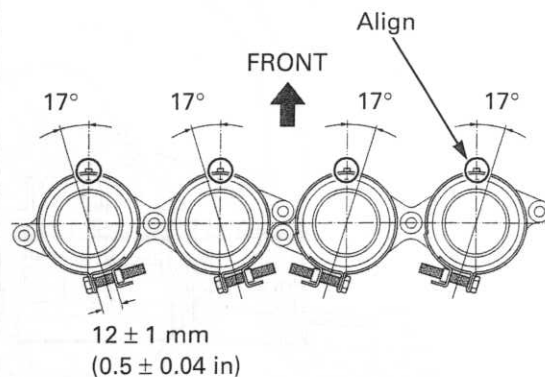
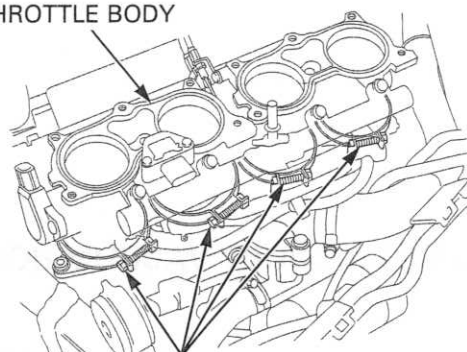

Connect the following:

- Primary injector 2P (Gray) connectors
- Knock sensor 3P (Black) connector
- TP sensor 3P (Black) connector
- IACV 4P (Black) connector

TP SENSOR CONNECTOR IACV CONNECTOR

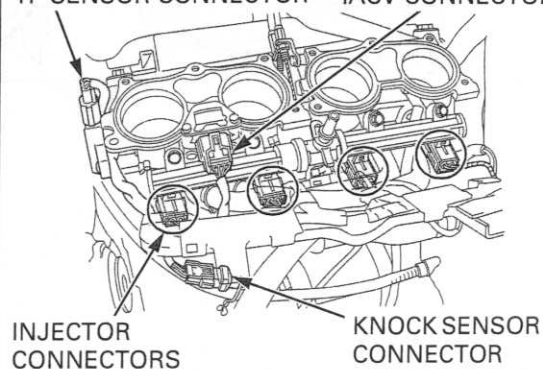

California type: Connect the vacuum hose to the 5-way joint securely.

Adjust the throttle grip freeplay (page 4-8).

Install the removed parts in the reverse order of removal.

California type shown:

5-WAY JOINT

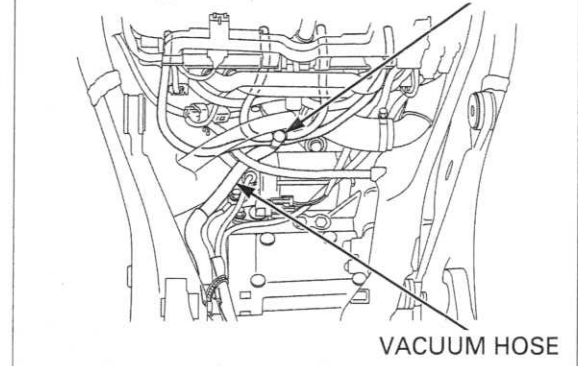

PRIMARY INJECTOR

INSPECTION

Lift and support the fuel tank (page 4-5).

Start the engine and let it idle.

Confirm the injector operating sounds with a sounding rod or stethoscope.

PRIMARY INJECTOR

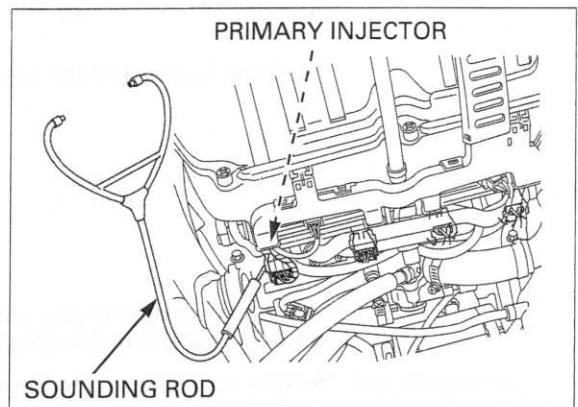

REMOVAL

Remove the throttle body (page 6-60).

Remove the bolts and fuel rail/primary injector assembly.

BOLTS

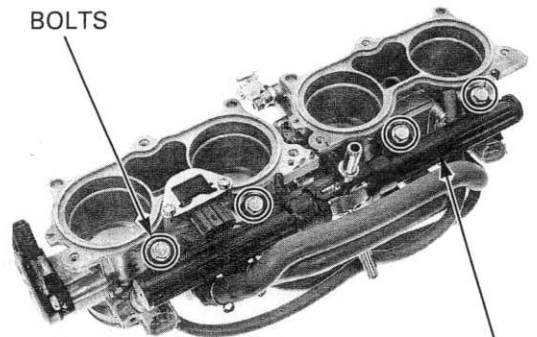

FUEL RAIL

FUEL RAIL

Remove the injectors from the fuel rail.

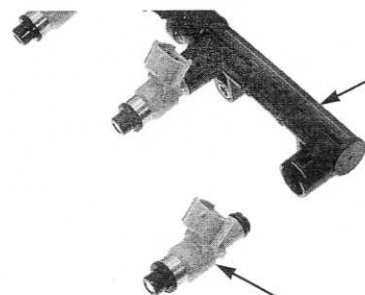

INJECTOR

FUEL SYSTEM (PGM-FI)

Remove the seal ring and O-ring.

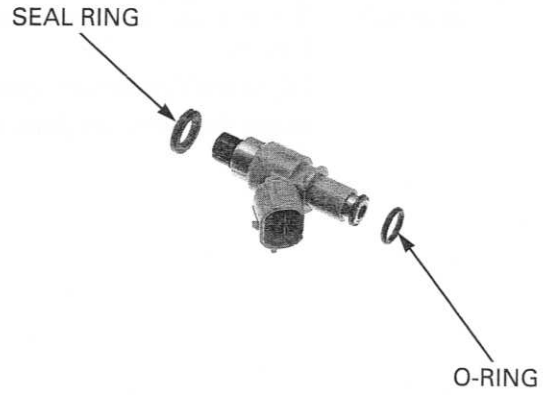

Remove the fuel rails and O-rings from the fuel rail joint.

INSTALLATION

Apply oil to new O-rings and install them to the fuel rail joint.

Install the fuel rails to the fuel rail joint.

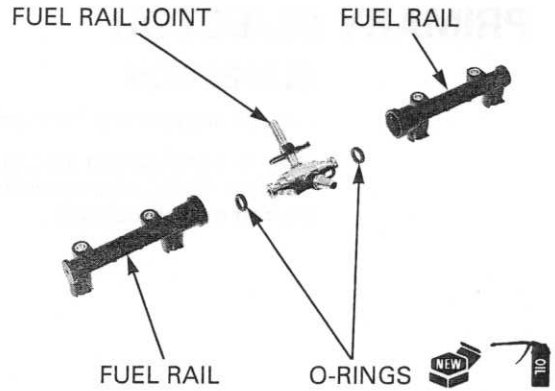

Apply oil to a new O-ring and install it to the injector, being careful not to damage the O-ring.

Install a new seal ring to the injector.

Replace the seal ring and O-ring with new ones as a set.

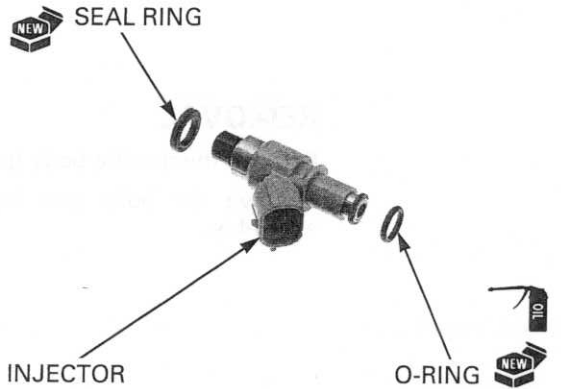

Install the injectors to the fuel rail, being careful not to damage the O-ring.

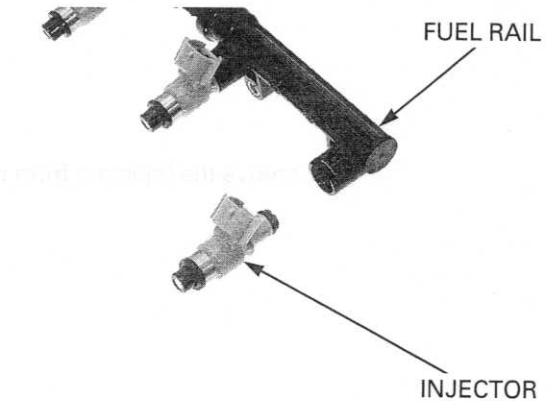

Install the fuel rail/primary injector assembly onto the throttle body, being careful not to damage the seal rings.

FUEL RAIL /PRIMARY INJECTOR ASSEMBLY

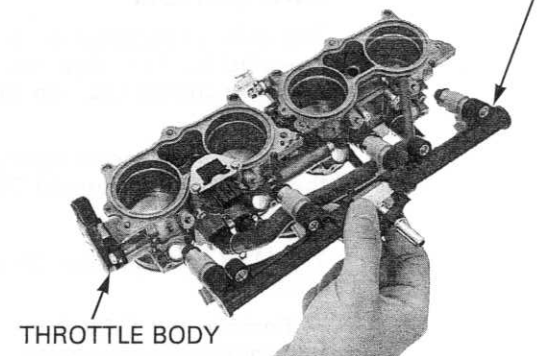

Tighten the fuel rail mounting bolts to the specified torque.

TORQUE: 5.1 N·m (0.5 kgf·m, 3.8 lbf·ft)

Install the throttle body (page 6-64).

BOLTS

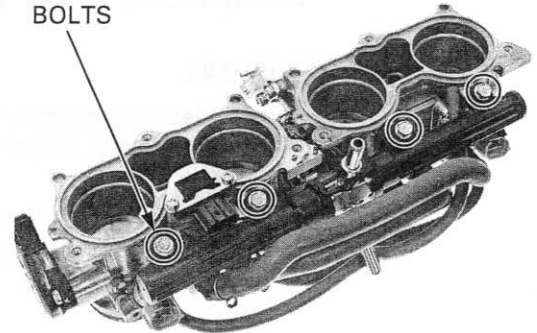

ENGINE IDLE SPEED

IDLE SPEED INSPECTION

- Inspect the idle speed after all other engine maintenance items have been performed and are within specifications.
- Before checking the idle speed, inspect the following items.
 - No DTC and MIL blinking
 - Spark plug condition (page 4-9)
 - Air cleaner condition (page 4-8)
- The engine must be warm for accurate idle speed inspection.
- This system eliminates the need for manual idle speed adjustment compared to previous designs.
- Use a tachometer with graduations of 50 rpm or smaller that will accurately indicate a 50 rpm change.

Lift and support the fuel tank (page 4-5).

Start the engine and warm it up to coolant temperature 80°C (176°F).

Stop the engine and connect a tachometer according to the tachometer manufacturer's operating instructions.

Start the engine and let it idle. Check the idle speed.

ENGINE IDLE SPEED: 1,400 ± 100 rpm

If the idle speed is out of the specification, check the following:

- Throttle operation and throttle grip freeplay (page 4-8)
- Intake air leak or engine top-end problem (page 9-6)
- IACV operation (page 6-68)

IACV

INSPECTION

The IACV is installed on the throttle body and is operated by the step motor. When the ignition switch is turned ON, the IACV operates for a few seconds.

Check the step motor operating (beep) sound with the ignition switch turned ON.

NOTE:

The IACV operation can be checked visually as follows:

- Remove the IACV (page 6-68). Connect the 4P (Black) connector to the IACV, then turn the ignition switch ON.

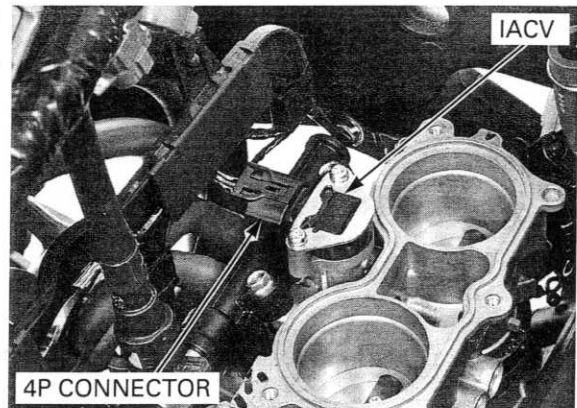

REMOVAL

- Always clean the throttle body before the IACV removal to prevent dirt and debris from entering the IACV passage.

Remove the throttle body (page 6-60).

Remove the torx screws and setting plate.

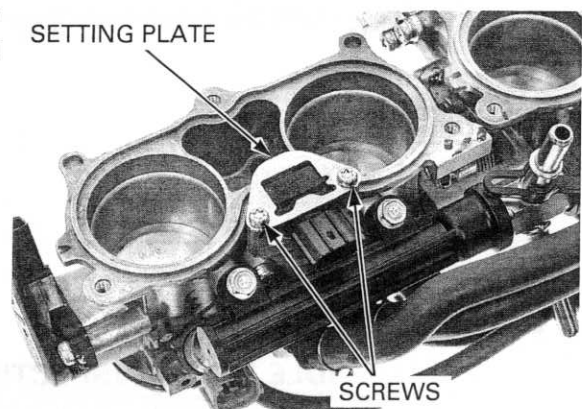

Remove the IACV motor.

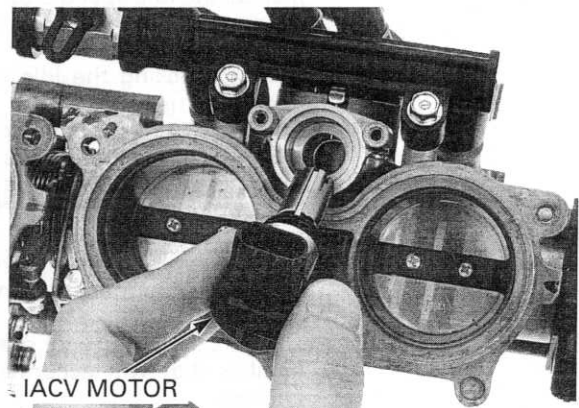

INSTALLATION

Turn the slide valve clockwise until lightly seated on IACV.

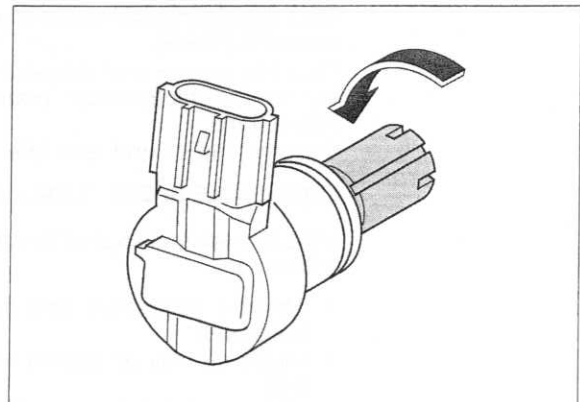

Install the IACV motor, aligning slide valve groove with the pin.

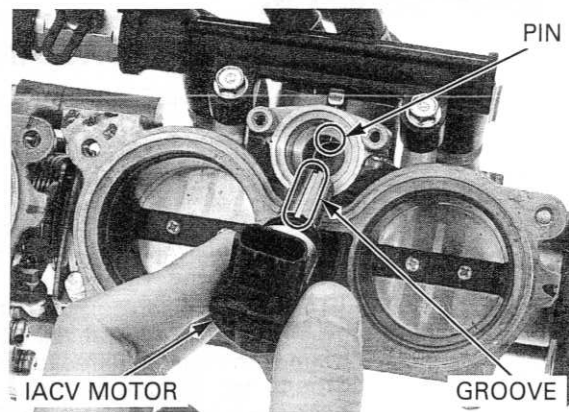

Install the setting plate while aligning the cut-out with the lug on the IACV motor.

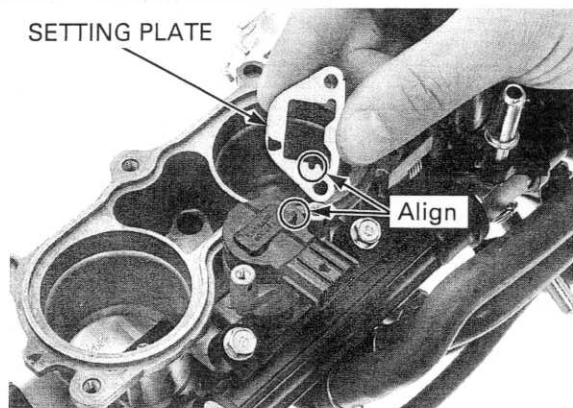

Install the torx screws and tighten them to the specified torque.

TORQUE: 2.1 N·m (0.2 kgf·m, 1.5 lbf·ft)

Install the throttle body (page 6-64).

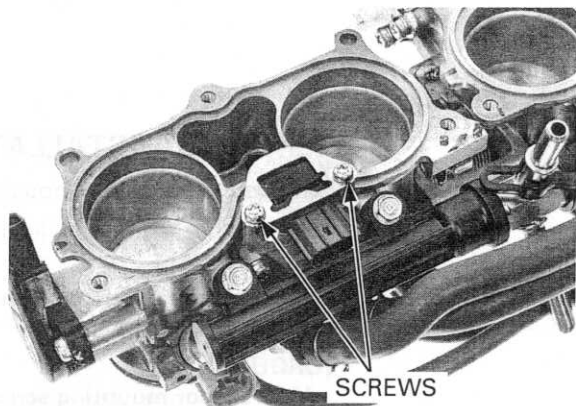

KNOCK SENSOR

REMOVAL/INSTALLATION

Remove the following:

- Starter motor (page 19-6)
- Thermostat housing (page 7-8)

Remove the bolt and knock sensor.

Installation is in the reverse order of removal.

TORQUE:

**Knock sensor mounting bolt:
22 N·m (2.2 kgf·m, 16 lbf·ft)**

Route the wire properly (page 1-21).

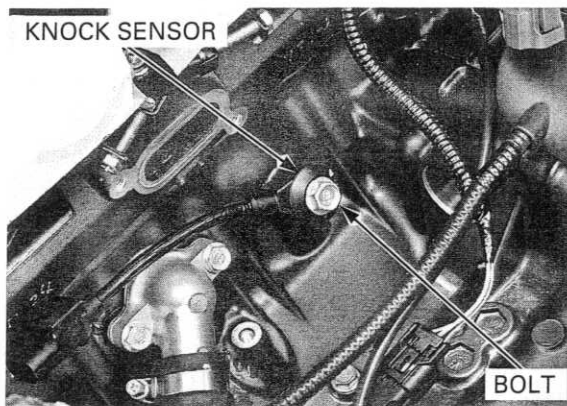

MAP SENSOR

OUTPUT VOLTAGE INSPECTION

Connect the HDS pocket tester (page 6-14).

View the voltage with HDS pocket tester.

Standard: 2.7 – 3.1 V

The MAP sensor output voltage (above) is measured under the standard atmosphere (1 atm = 1,013 hPa).

The MAP sensor output voltage is affected by the distance above sea level, because the output voltage is changed by atmospheric pressure.

Check the altitude and be sure that the measured voltage falls within the specified value.

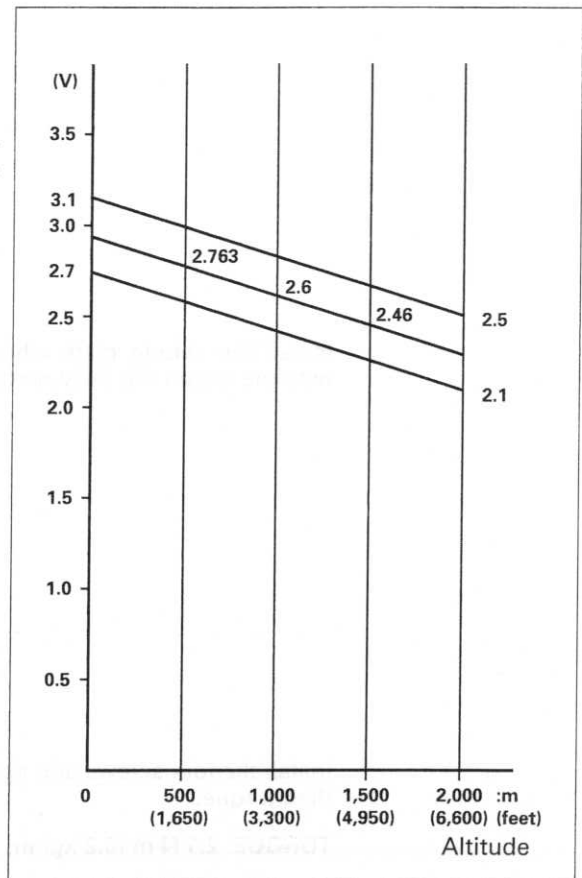

REMOVAL/INSTALLATION

Remove the air cleaner housing (page 6-52).

Remove the screw and MAP sensor from the air cleaner housing.

Install the removed parts in the reverse order of removal.

TORQUE:

MAP sensor mounting screw:
1.1 N·m (0.1 kgf·m, 0.8 lbf·ft)

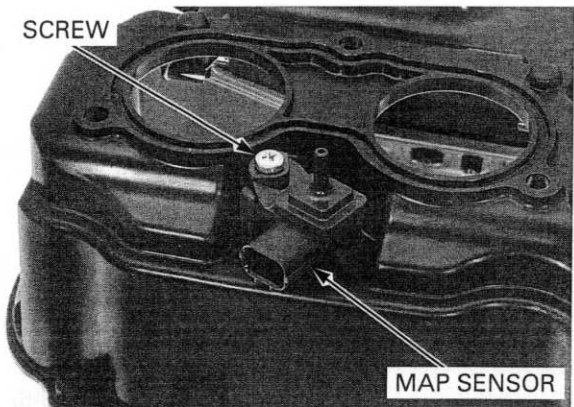

IAT SENSOR

REMOVAL/INSTALLATION

Remove the fuel tank cover (page 3-9).

Disconnect the IAT sensor 2P (Gray) connector.

Remove the screws and IAT sensor from the air cleaner housing cover.

Installation is in the reverse order of removal.

TORQUE:

IAT sensor mounting screw:
1.1 N·m (0.1 kgf·m, 0.8 lbf·ft)

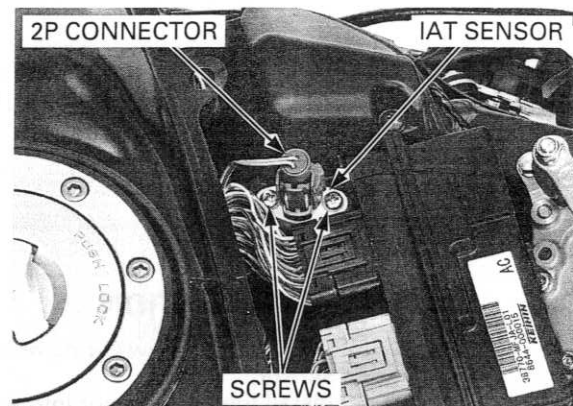

ECT SENSOR

REMOVAL

Replace the ECT sensor while the engine is cold.

Drain the coolant from the system (page 7-7).

Lift and support the fuel tank (page 4-5).

Disconnect the ECT sensor 3P (Gray) connector.

Remove the ECT sensor and sealing washer.

INSTALLATION

Always replace a sealing washer with a new one.

Install a new sealing washer and ECT sensor. Tighten the ECT sensor to the specified torque.

TORQUE: 23 N·m (2.3 kgf·m, 17 lbf·ft)

Connect the ECT sensor 3P (Gray) connector.

Remove the suitable support and close the fuel tank (page 4-6).

Fill the cooling system with recommended coolant (page 7-7).

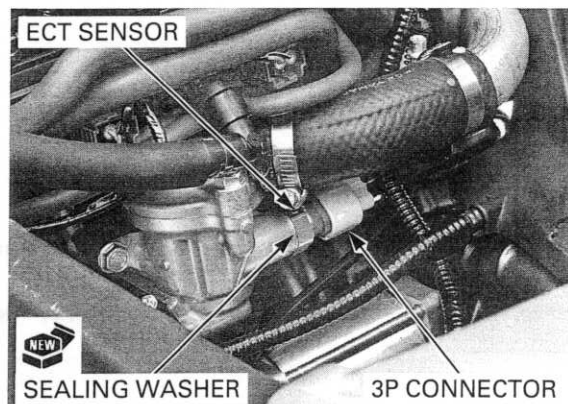

CMP SENSOR

REMOVAL

Remove the left middle cowl (page 3-8).

Disconnect the CMP sensor 2P (Black) connector.

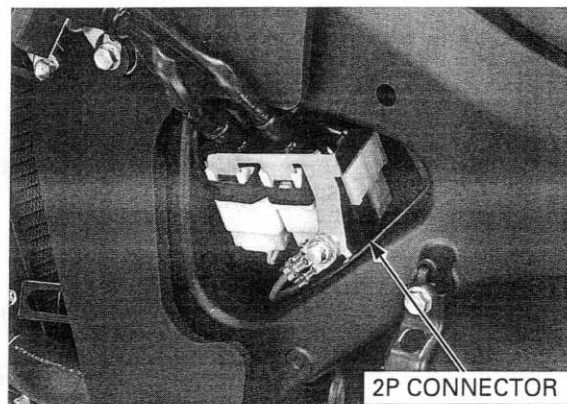

FUEL SYSTEM (PGM-FI)

Remove the bolt, wire clamp CMP sensor and O-ring from the cylinder head.

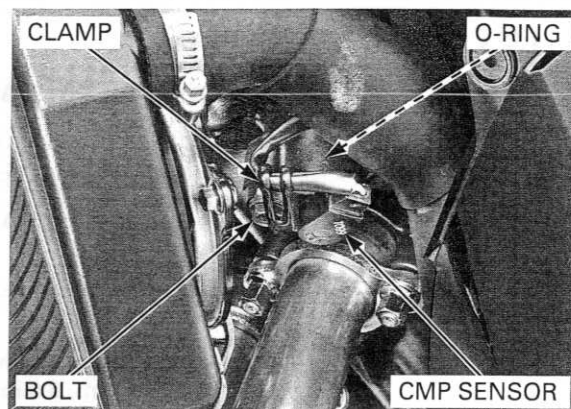

INSTALLATION

Apply oil to a new O-ring and install it onto the CMP sensor. Install the CMP sensor into the cylinder head.

Route the wire properly (page 1-21).

Install the wire clamp and tighten the mounting bolt securely.

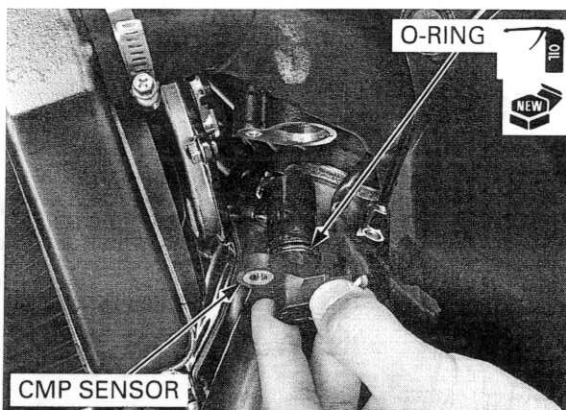

Route the CMP sensor wire properly, connect the 2P (Black) connector.

Install the left middle cowl (page 3-8).

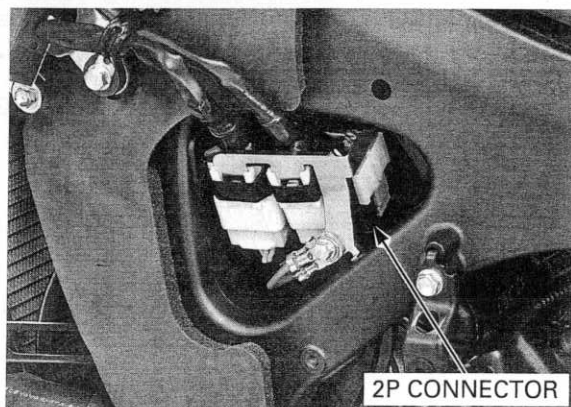

BANK ANGLE SENSOR

INSPECTION

Remove the upper cowl/front spoiler (page 3-11).

Connect the special tool between the bank angle sensor and wire harness.

TOOL:

Inspection adaptor

07GMJ-ML80100

Turn the ignition switch ON and engine stop switch "O".

Measure the voltage between the following terminals of the special tool.

TERMINAL	STANDARD
White (+) - Green (-)	Battery voltage
Red (+) - Green (-)	0 - 1 V

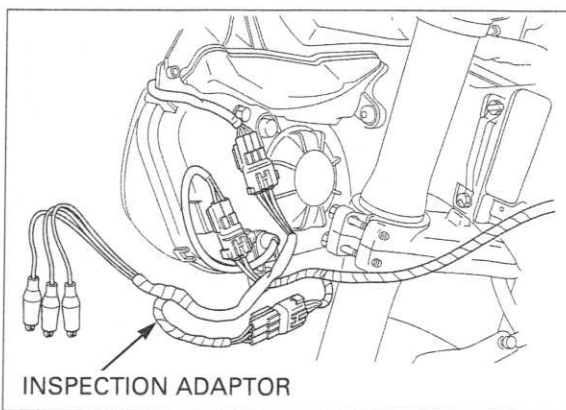

Do not disconnect the bank angle sensor connector during inspection.

Turn the ignition switch OFF.
Remove the screws, washers and bank angle sensor.

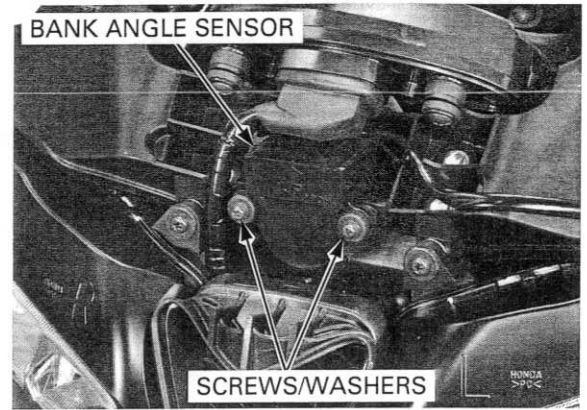

Place the bank angle sensor horizontal as shown, and turn the ignition switch ON.

The bank angle sensor is normal if the engine stop relay clicks and power supply is closed.

Incline the bank angle sensor approximately 60° to the left or right with the ignition switch ON. The bank angle sensor is normal if the engine stop relay clicks and power supply is open.

If you repeat this test, first turn the ignition switch OFF, then turn the ignition switch ON.

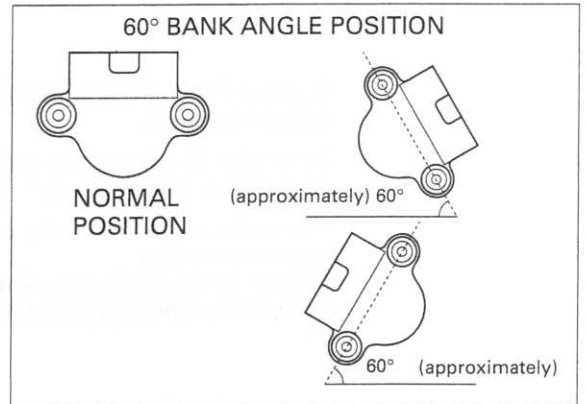

REMOVAL/INSTALLATION

Remove the upper cowl/front spoiler (page 3-11).
Disconnect the bank angle sensor 3P (Black) connector.
Remove the screws and bank angle sensor.

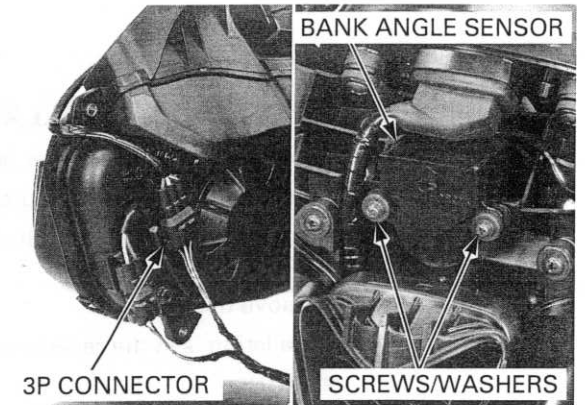

Install the bank angle sensor with its "UP" mark facing up.

Installation is in the reverse order of removal.
Tighten the bank angle sensor mounting screws to the specified torque.

TORQUE: 1.5 N·m (0.2 kgf·m, 1.1 lbf·ft)

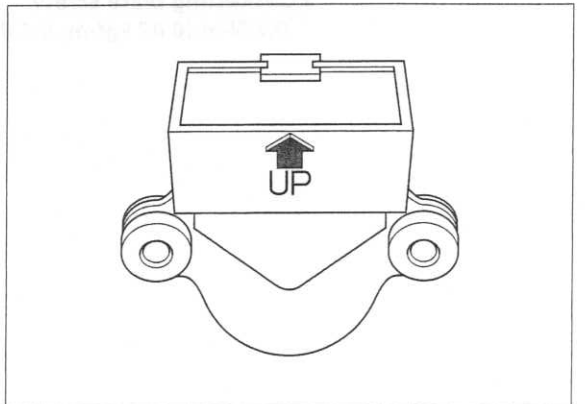

ENGINE STOP RELAY

INSPECTION

Remove the seat (page 3-4).

Open the fuse/relay box and remove the engine stop relay.



Connect the ohmmeter to the engine stop relay connector terminals.

Connect a 12 V battery to the engine stop relay connector terminals as shown.

There should be continuity only when the 12 V battery is connected.

If there is no continuity when the 12 V battery is connected, replace the engine stop relay.

ENGINE STOP RELAY

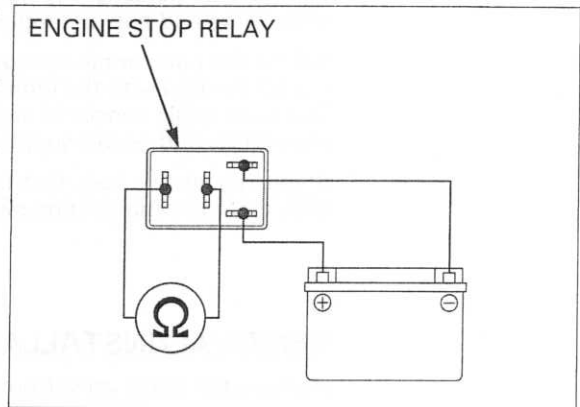

ECM

REMOVAL/INSTALLATION

Remove the fuel tank cover (page 3-9).

Remove the screws, setting plate and ECM.

Disconnect the ECM 33P (Black) and 33P (Gray) connectors.

Remove the ECM.

Installation is in the reverse order of removal.

TORQUE:

ECM setting plate screw:

0.7 N·m (0.07 kgf·m, 0.5 lbf·ft)

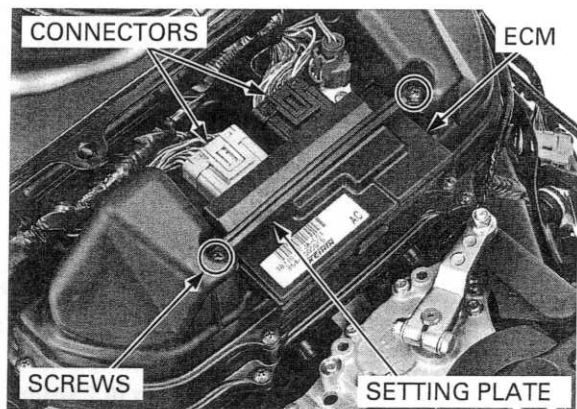

POWER/GROUND LINE INSPECTION

ENGINE DOES NOT START (MIL DOES NOT BLINK)

1. ECM Power Input Voltage Inspection

Disconnect the ECM 33P connectors (page 6-74).

Turn the ignition switch ON and engine stop switch "O".

Measure the voltage at the ECM 33P (Black) connector terminals and ground.

Connection: A4 (+) – Ground (-)
A5 (+) – Ground (-)

TOOL:

Test probe 07ZAJ-RDJA110

Is there battery voltage?

YES – GO TO STEP 2.

NO – GO TO STEP 3.

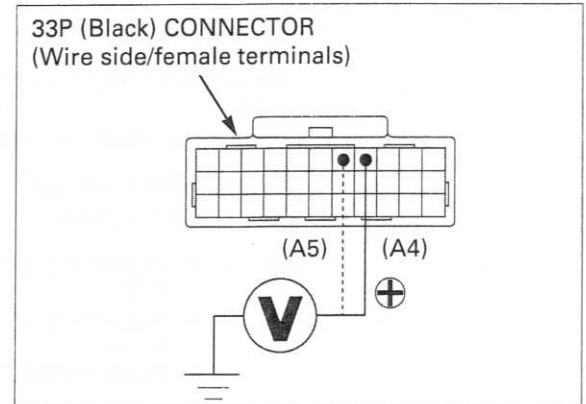

2. ECM Ground Line Inspection

Turn the ignition switch OFF.

Check for continuity between the ECM 33P connector terminal and ground.

Connection: B4 – Ground
A23 – Ground
A24 – Ground
A25 – Ground

TOOL:

Test probe 07ZAJ-RDJA110

Is there continuity?

YES – Replace the ECM with a known good one, and recheck

NO – Open circuit in Ground line

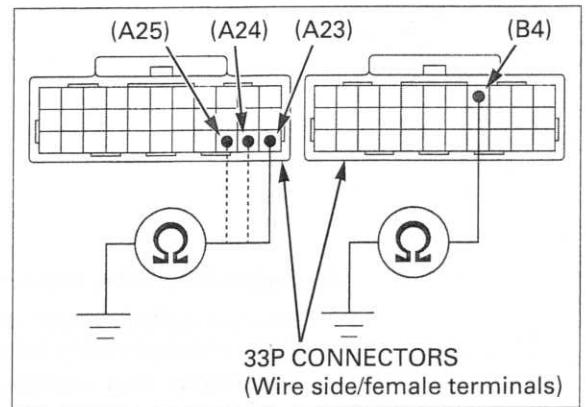

FUEL SYSTEM (PGM-FI)

3. Engine Stop Relay Inspection 1

Turn the ignition switch OFF.

Open the fuse/relay box and remove the engine stop relay.

Turn the ignition switch ON and engine stop switch "O".

Measure the voltage at the engine stop relay terminals.

Connection: Black (+) – Red/blue (-)

Is there battery voltage?

YES – GO TO STEP 4.

- NO** –
- Inspect the bank angle sensor (page 6-72)
 - Inspect the engine stop switch (page 20-18)
 - Blown fuse (BANK ANGLE 10A)

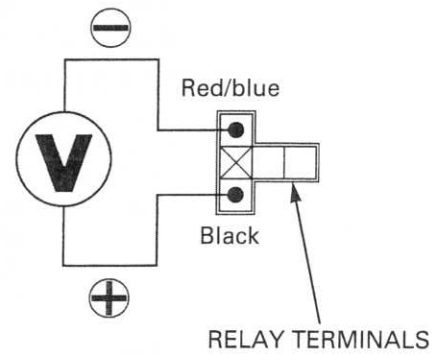
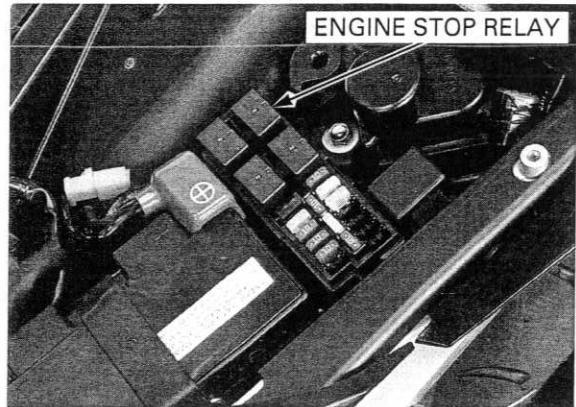

4. Engine Stop Relay Inspection 2

Turn the ignition switch OFF.

Jump the engine stop relay connector terminals.

Connection: Red – Black/white

Turn the ignition switch ON.

Measure the voltage at the ECM connector terminals and ground.

Connection: A4 (+) – Ground (-)
A5 (+) – Ground (-)

TOOL:

Test probe 07ZAJ-RDJA110

Is there battery voltage?

YES – Inspect the engine stop relay (page 6-74)

NO – Open circuit in power input line (Black/white or Red) between the battery and ECM

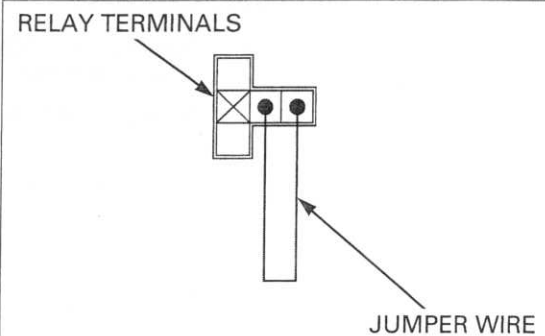

33P (Black) CONNECTOR
(Wire side/female terminals)

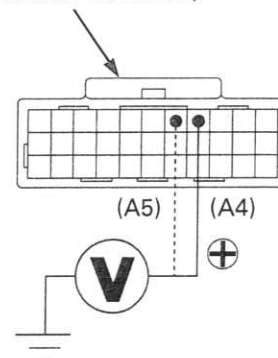

SECONDARY AIR SUPPLY SYSTEM

SYSTEM INSPECTION

Start the engine and warm it up to coolant temperature is 80°C (176°F).

Stop the engine.

Remove the air cleaner middle housing (page 6-52).

Check that the secondary air intake port is clean and free of carbon deposits.

Check the PAIR check valves if the port for carbon fouling (page 9-8).

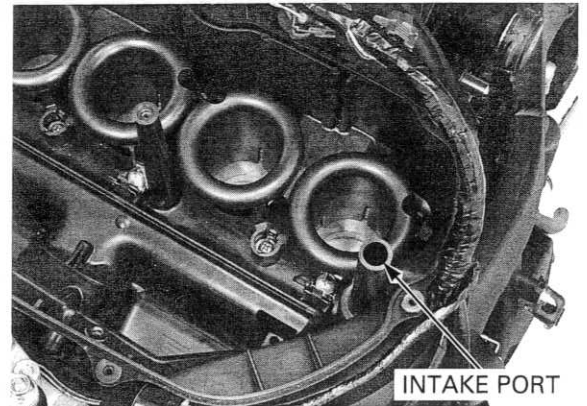

Start the engine and open the throttle slightly to be certain that air is sucked in through the air intake port.

If the air is not drawn in, check the air suction hoses for clogs and PAIR solenoid valve.

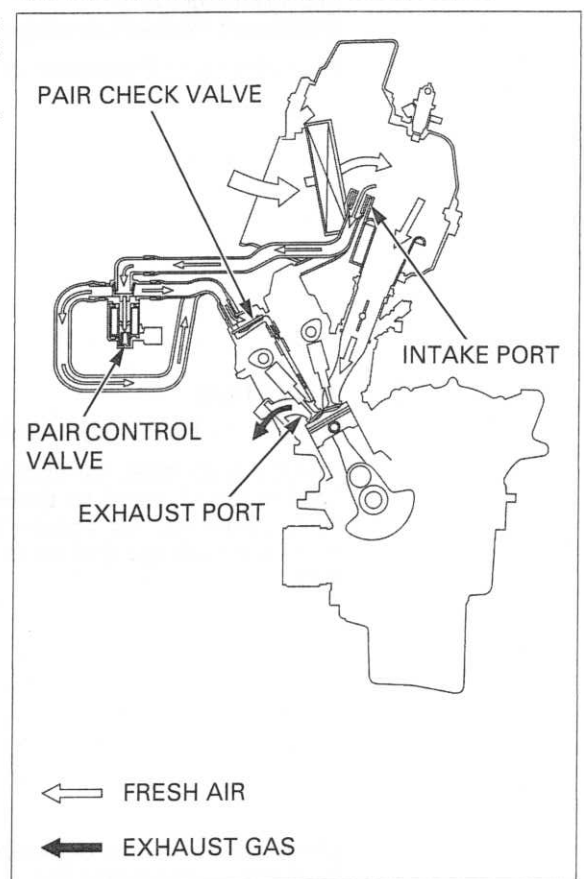

FUEL SYSTEM (PGM-FI)

PAIR CONTROL SOLENOID VALVE

REMOVAL/INSTALLATION

Remove the air cleaner housing (page 6-52).

Remove the air intake joint from the frame.

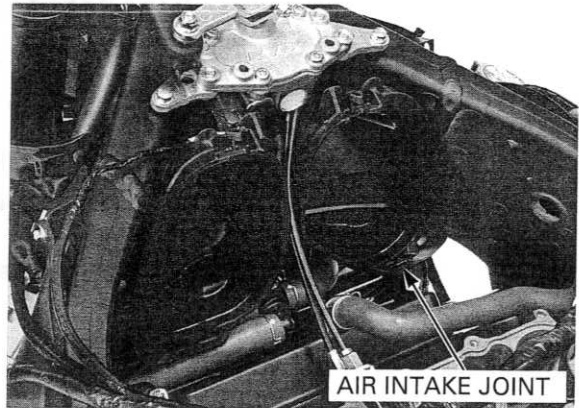

Disconnect the PAIR control solenoid valve 2P (Black) connector.

Disconnect the PAIR air suction hoses.

Installation is in the reverse order of removal.

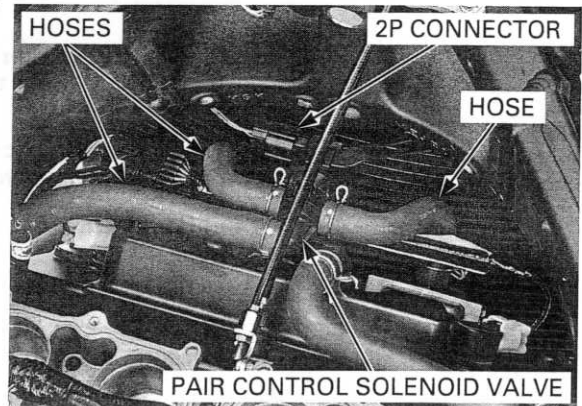

INSPECTION

Remove the PAIR control solenoid valve.

Check that air does not flow (A) to (B) when a 12 V battery is connected to the PAIR control solenoid valve terminals. Air should flow (A) to (B) when there is no voltage applied to the PAIR valve terminals.

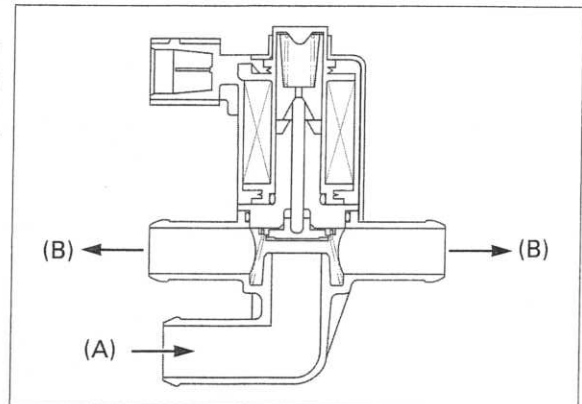

Check the resistance between the terminals of the PAIR control solenoid valve.

Standard: 23 – 27 Ω (20°C/68°F)

If the resistance is out of specification, replace the PAIR control solenoid valve.

2P CONNECTOR
(Solenoid valve side/male terminals)

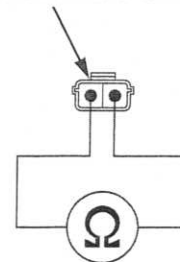

EVAP PURGE CONTROL SOLENOID VALVE/CANISTER (CALIFORNIA TYPE)

REMOVAL/INSTALLATION

Remove the shock absorber (page 15-14).

Disconnect the following:

- EVAP purge control solenoid valve 2P (Black) connector
- Fuel tank breather hose (to fuel tank)
- Canister-to-purge control solenoid valve hose
- EVAP canister drain hose

Remove the bolts, collars, EVAP canister and Canister bracket.

Remove the bolts, collars, EVAP purge control solenoid valve and solenoid valve bracket.

Installation is in the reverse order of removal.

Route the hoses properly (page 1-34).

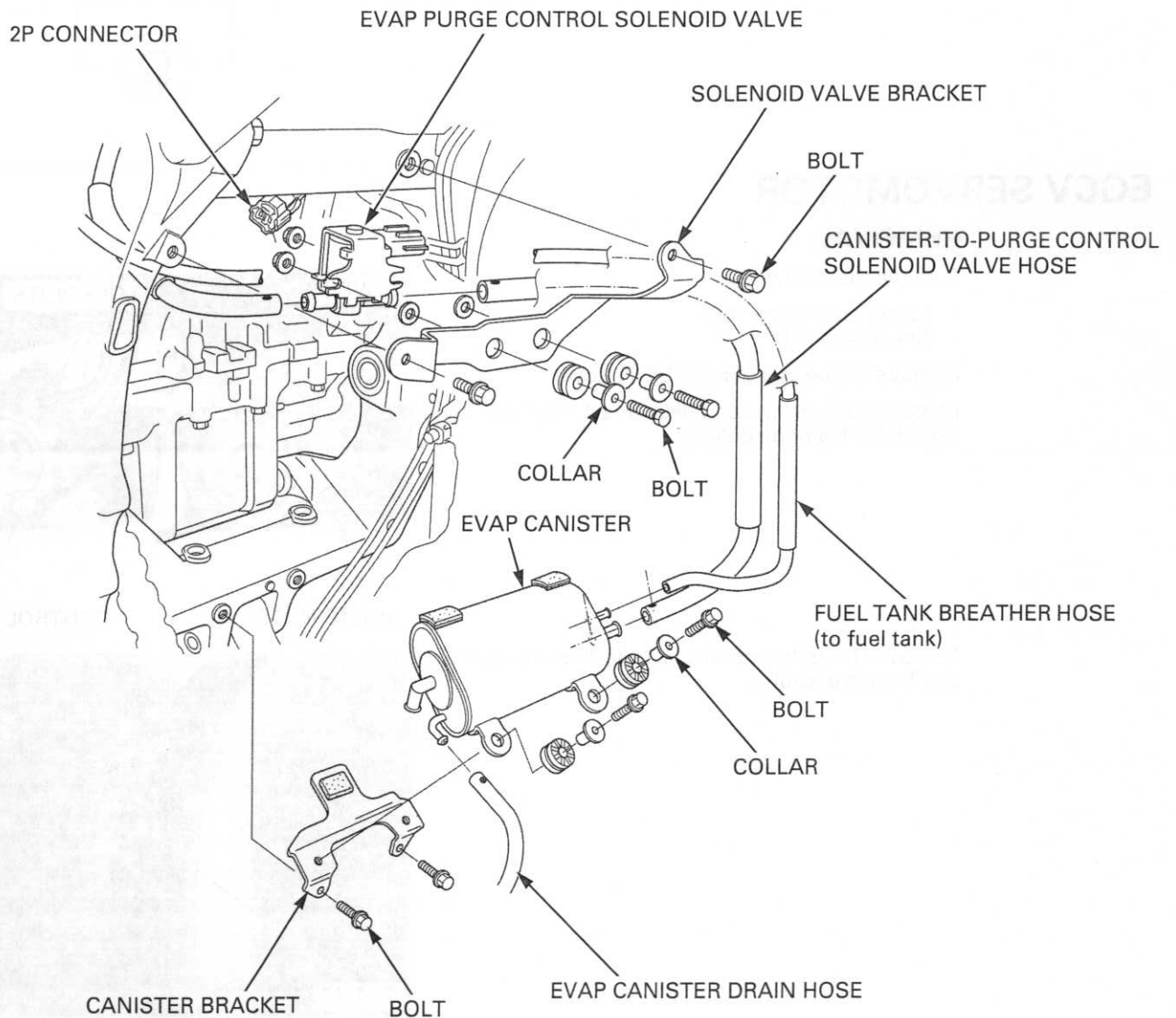

FUEL SYSTEM (PGM-FI)

INSPECTION

Remove the EVAP purge control solenoid valve (page 6-79).

Check that air should not flow (A) to (B), only when a 12 V battery is connected to the EVAP purge control solenoid valve terminals.

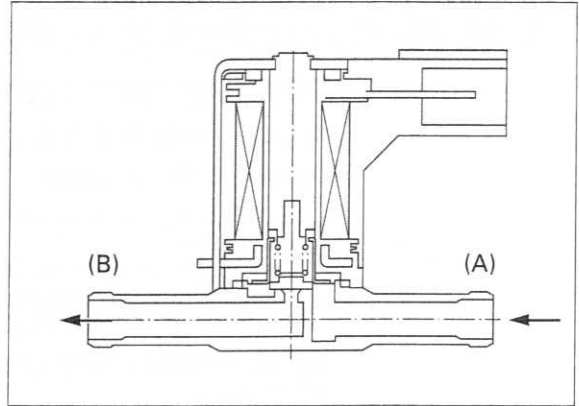

Check the resistance between the terminals of the EVAP purge control solenoid valve.

STANDARD: 30 – 34 Ω (20°C/68°F)

If the resistance is out of specification, replace the EVAP purge control solenoid valve.

2P CONNECTOR
(Solenoid valve side/male terminals)

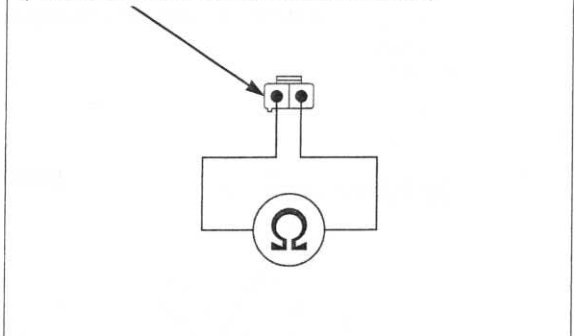

EGCV SERVOMOTOR

REMOVAL

Remove the following:

- Lower cowl (page 3-6)
- Seat (page 3-4)

Remove the bolts, nuts and EGCV cover.

Loosen the lock nuts and disconnect the EGCV control cables from the pulley.

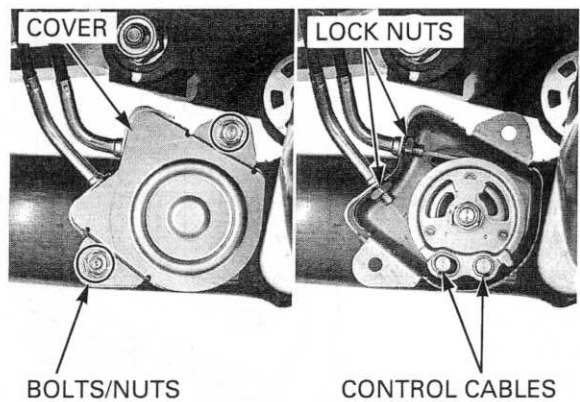

Remove the bolt and wire clamp, then release the EGCV control cables.

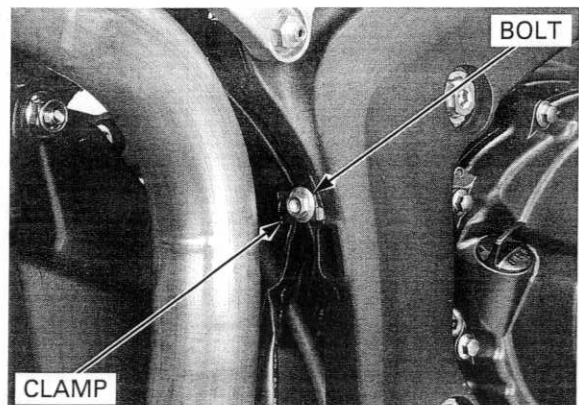

Disconnect the servomotor 6P (Natural) connector.
Remove the bolts, collar, cover and servomotor.

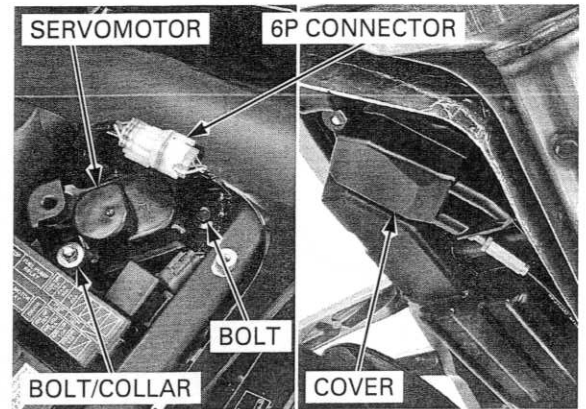

Disconnect the EGCV control cables from the servomotor pulley.

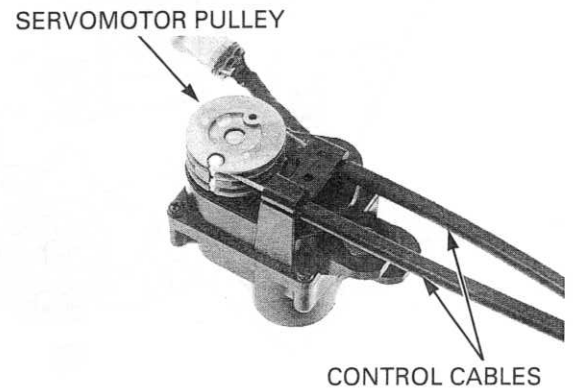

INSPECTION

Connect a 12 V battery to the servomotor 6P (Natural) connector terminals and check that the motor operation.

Connection: Red (+) – Blue (-)

If the servomotor does not turn, replace the servomotor with a new one.

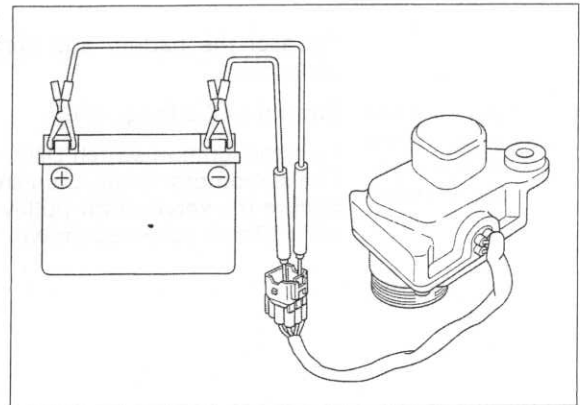

Measure the resistance between the servomotor 6P (Natural) connector terminals.

Connection: Yellow/red – Green

Standard: 5 kΩ

Connection: Brown – Green

Standard: 0 – 5 kΩ

If the resistance is out of range, replace the servomotor.

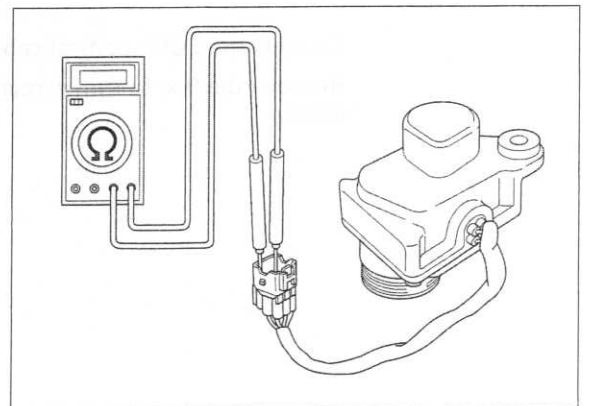

FUEL SYSTEM (PGM-FI)

INSTALLATION

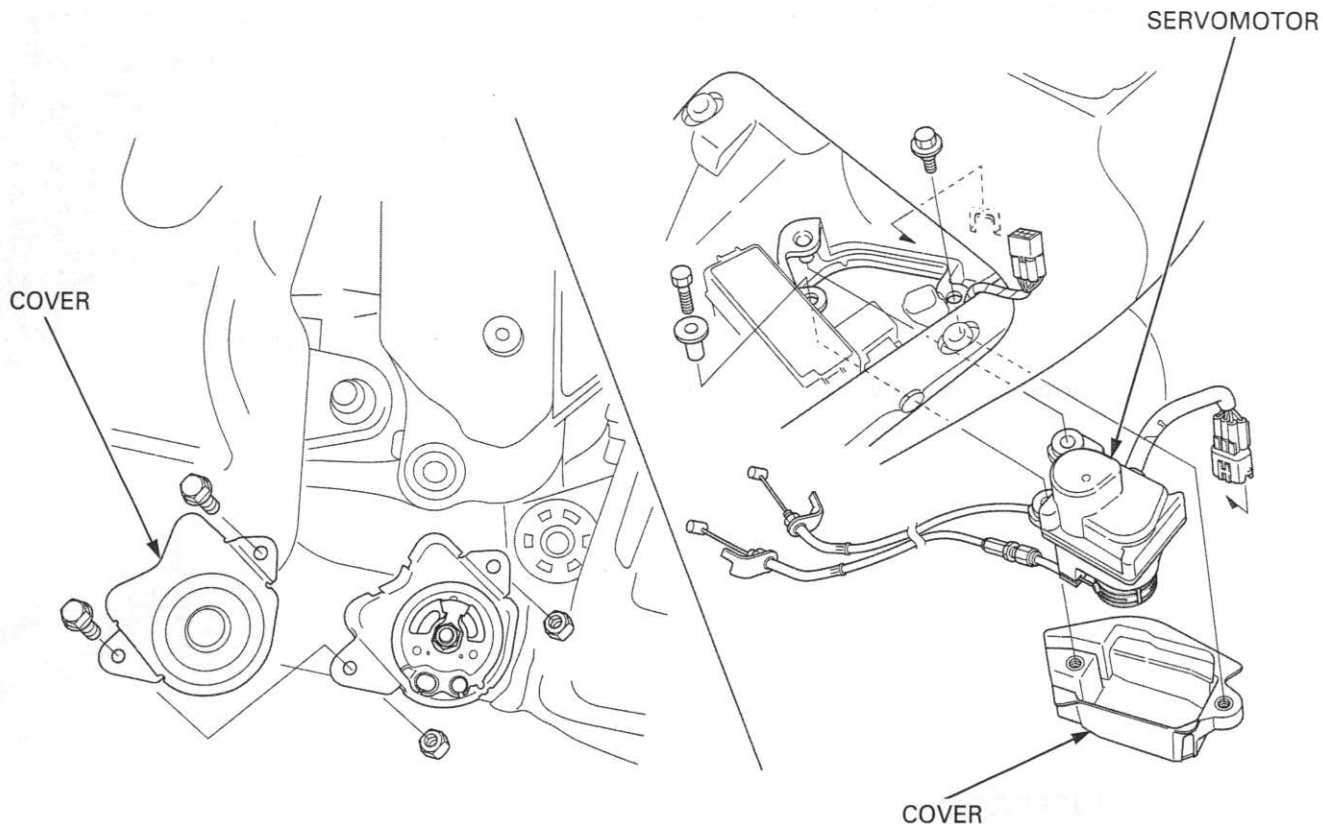

Connect the battery and servomotor 6P (Natural) connector.

If you use a new servomotor, it is not necessary to do this procedure.

Short the DLC (page 6-15).

Turn the ignition switch ON.

The servomotor turns, then stops.

Secure the servomotor pulley at this position using a 3 x 18 mm screw as shown.

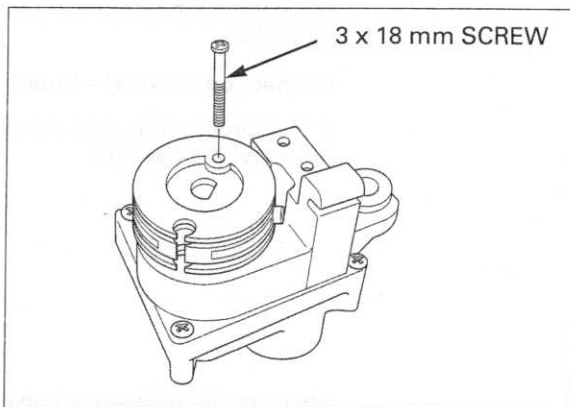

Connect the EGCV control cables to each position.

Remove the 3 x 18 mm screw from the servomotor pulley.

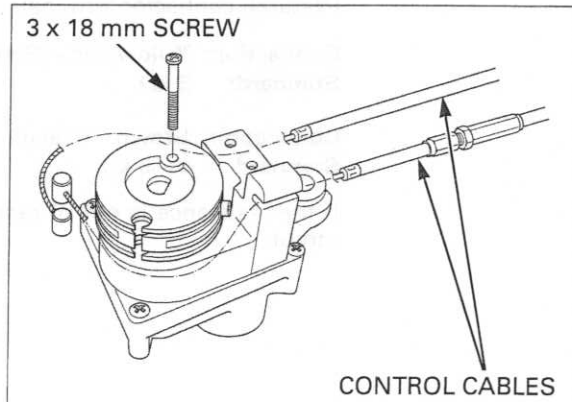

Install the servomotor, cover, collar and tighten the bolts securely.

Connect the servomotor 6P (Natural) connector.

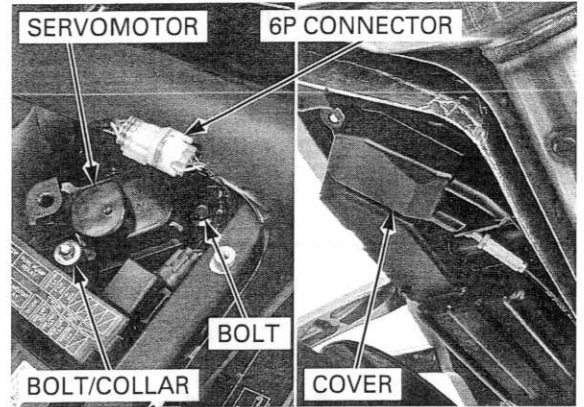

Route the cables properly (page 1-21). Install the wire clamp and tighten the bolt securely.

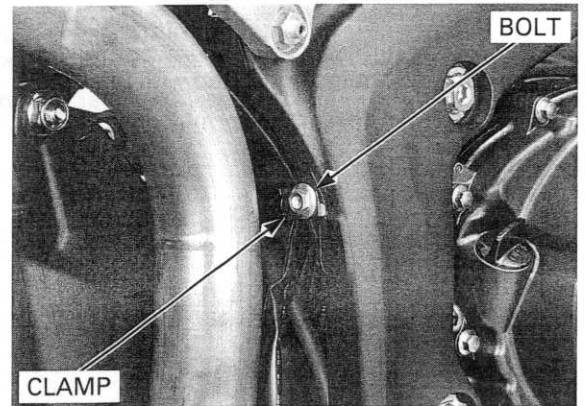

Connect the EGCV control cables to the pulley and tighten the lock nut securely.

Adjust the EGCV control cable (page 4-22).

Install the EGCV cover, bolts and tighten the nuts securely.

Install the following:

- Seat (page 3-4)
- Lower cowl (page 3-6)

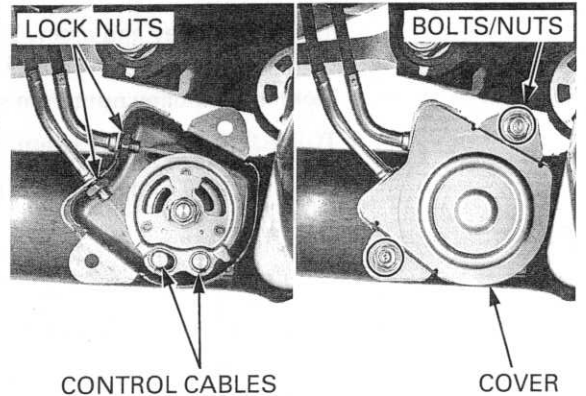

EGCV

DISASSEMBLY

Remove the lower cowl (page 3-6).

Remove the bolts, nuts and EGCV cover.

Loosen the lock nuts and disconnect the EGCV control cables from the pulley.

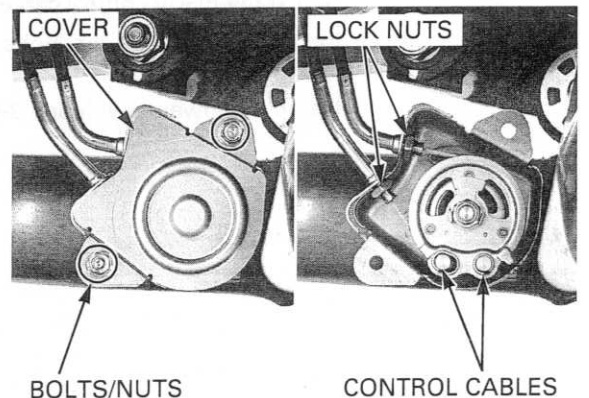

FUEL SYSTEM (PGM-FI)

Bend the tabs of the lock washer away from the pulley nut.

Hold the pulley and remove the pulley nut.

Remove the lock washer, pulley, spring collar and return spring.

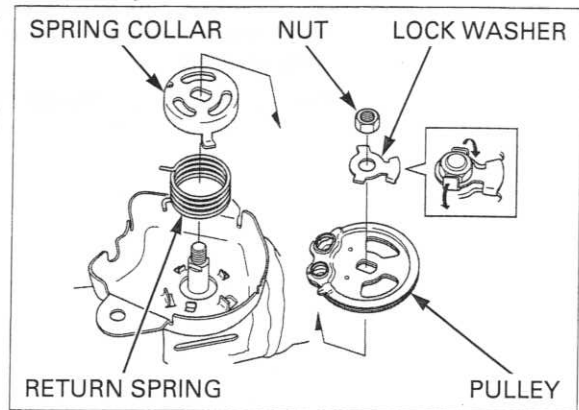

ASSEMBLY

Install the return spring onto the housing while aligning its end with the housing boss.

Install the spring collar as shown.

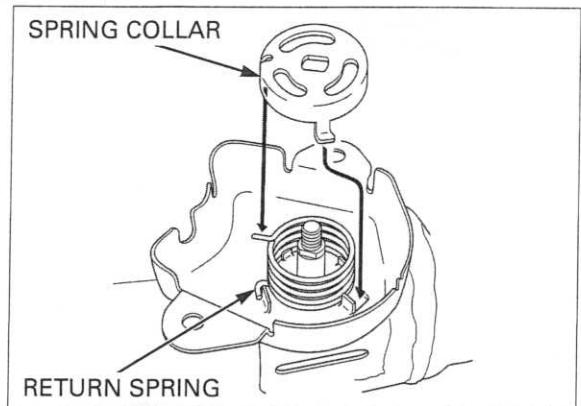

Install the pulley and a new lock washer while aligning its tabs with the pulley as shown.

Tighten the pulley nut to the specified torque.

TORQUE: 5.0 N·m (0.5 kgf·m, 3.7 lbf·ft)

Bend the tabs of the lock washer up against the pulley nut.

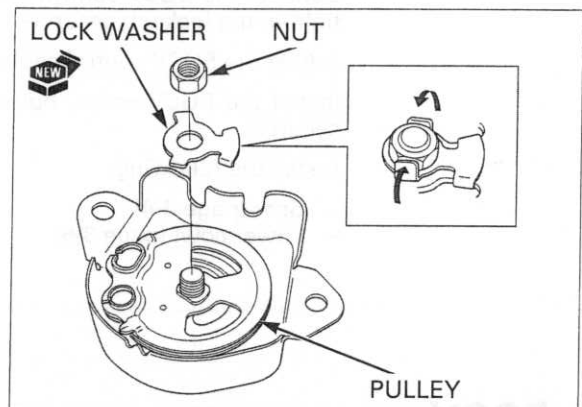

Connect the EGCV control cables to the pulley and tighten the lock nuts securely.

Adjust the EGCV control cable (page 4-22).

Install the EGCV cover, bolts and tighten the nuts securely.

Install the lower cowl (page 3-6).

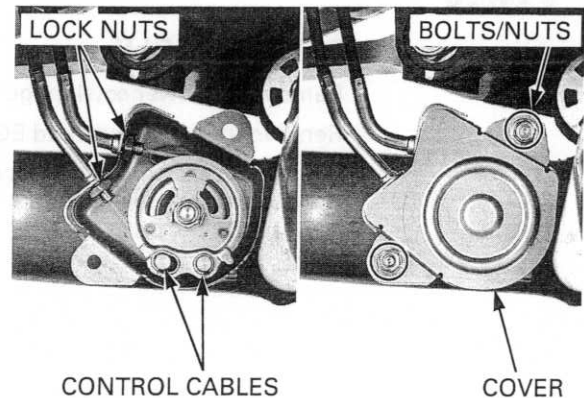

7. COOLING SYSTEM

SYSTEM FLOW PATTERN	7-2	THERMOSTAT HOUSING.....	7-8
SERVICE INFORMATION	7-3	RADIATOR	7-11
TROUBLESHOOTING	7-4	WATER PUMP	7-16
SYSTEM TESTING.....	7-5	RADIATOR RESERVE TANK.....	7-20
COOLANT REPLACEMENT	7-6	FAN MOTOR RELAY	7-20

COOLING SYSTEM

SYSTEM FLOW PATTERN

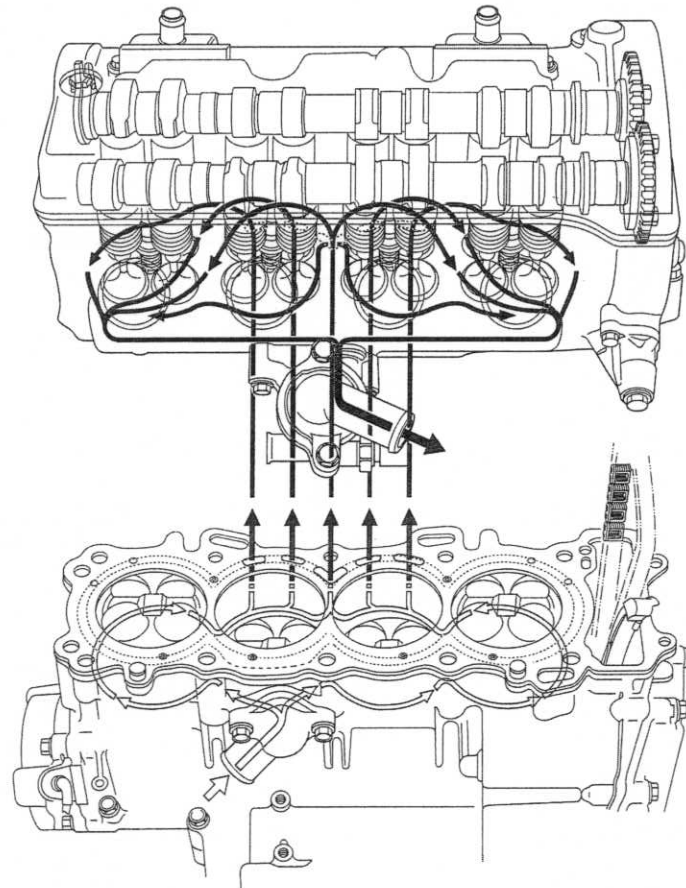
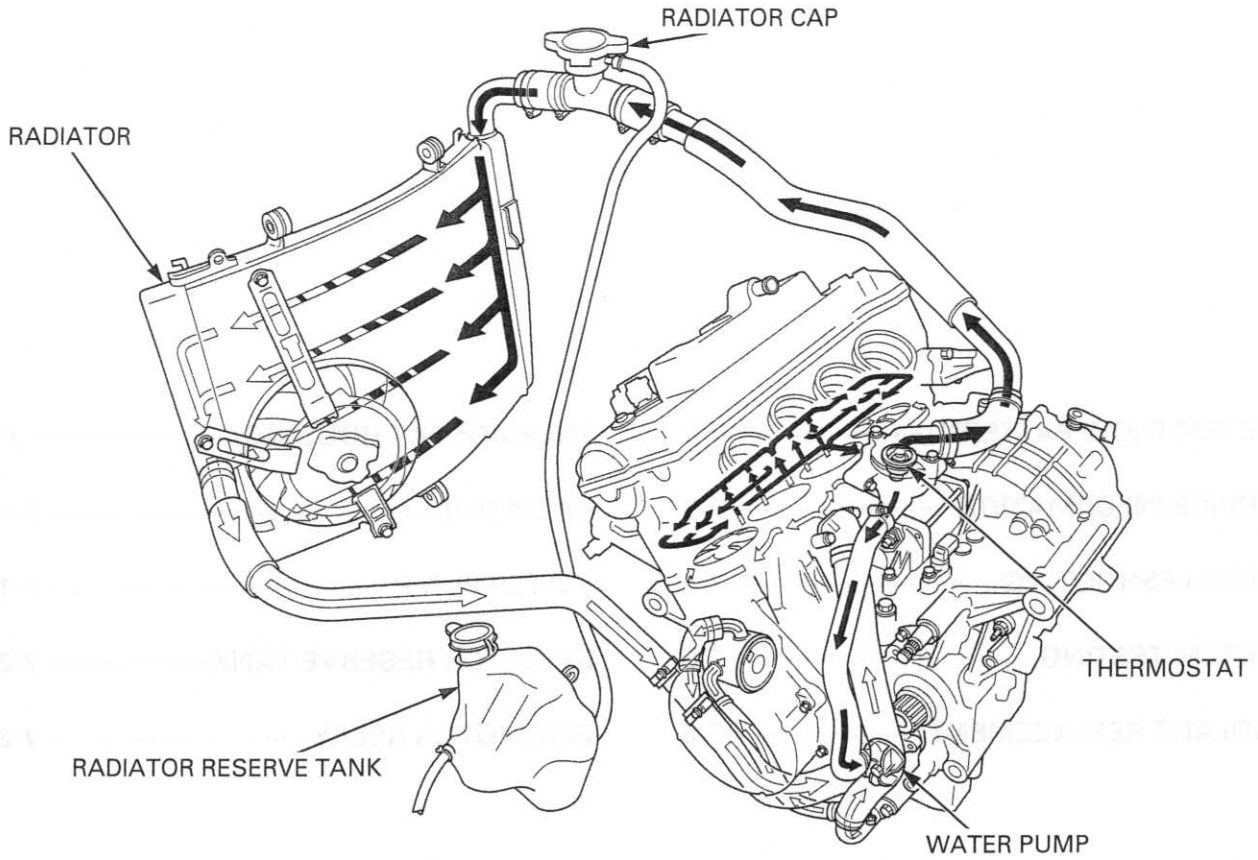

SERVICE INFORMATION

GENERAL

▲ WARNING

Removing the radiator cap while the engine is hot can allow the coolant to spray out, seriously scalding you. Always let the engine and radiator cool down before removing the radiator cap.

NOTICE

Using coolant with silicate inhibitors may cause premature wear of water pump seals or blockage of radiator passages. Using tap water may cause engine damage.

- Add coolant at the reserve tank. Do not remove the radiator cap except to refill or drain the system.
- All cooling system services can be done with the engine installed in the frame.
- Avoid spilling coolant on painted surfaces.
- After servicing the system, check for leaks with a cooling system tester.
- Refer to the ECT sensor inspection (page 20-14).

SPECIFICATIONS

ITEM		SPECIFICATIONS
Coolant capacity	Radiator and engine	3.15 liter (3.33 US qt, 2.77 Imp qt)
	Reserve tank	0.30 liter (0.32 US qt, 0.26 Imp qt)
Radiator cap relief pressure		108 – 137 kPa (1.1 – 1.4 kgf/cm ² , 16 – 20 psi)
Thermostat	Begin to open	80 – 84°C (176 – 183°F)
	Fully open	95°C (203°F)
	Valve lift	8 mm (0.3 in) minimum
Recommended antifreeze		Pro Honda HP Coolant or an equivalent high quality ethylene glycol antifreeze containing silicate free corrosion inhibitors
Standard coolant concentration		1:1 (mixture with distilled water)

TORQUE VALUES

Water pump assembly bolt	12 N·m (1.2 kgf·m, 9 lbf·ft)	CT bolt
Water pump drain bolt	12 N·m (1.2 kgf·m, 9 lbf·ft)	CT bolt
Thermostat housing cover bolt	12 N·m (1.2 kgf·m, 9 lbf·ft)	CT bolt
ECT sensor	23 N·m (2.3 kgf·m, 17 lbf·ft)	
Fan motor shroud mounting bolt	8.4 N·m (0.9 kgf·m, 6.2 lbf·ft)	

COOLING SYSTEM

TROUBLESHOOTING

Engine temperature too high

- Faulty engine coolant temperature meter or ECT sensor
- Thermostat stuck closed
- Faulty radiator cap
- Insufficient coolant
- Passage blocked in radiator, hoses or water jacket
- Air in system
- Faulty cooling fan motor
- Faulty fan motor relay
- Faulty water pump

Engine temperature too low

- Faulty temperature gauge or ECT sensor
- Thermostat stuck open
- Faulty fan motor relay

Coolant leak

- Faulty water pump mechanical seal
- Deteriorated O-rings
- Faulty radiator cap
- Damaged or deteriorated cylinder head gasket
- Loose hose connection or clamp
- Damaged or deteriorated hose

SYSTEM TESTING

COOLANT (HYDROMETER TEST)

Remove the right middle cowl (page 3-8).
Remove the radiator cap.

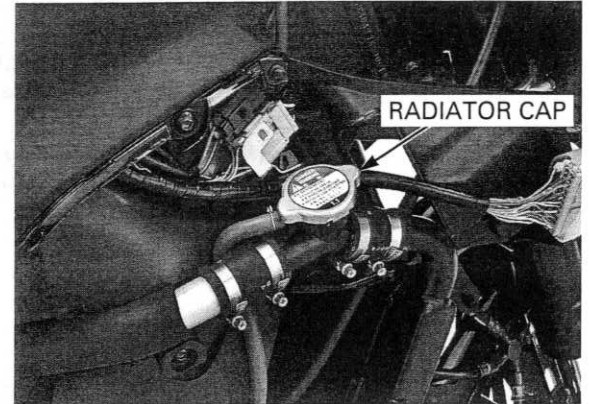

Test the coolant gravity using a hydrometer (see below for "Coolant gravity chart").
For maximum corrosion protection, a 1:1 solution of ethylene glycol and distilled water is recommended (page 7-6).
Look for contamination and replace the coolant if necessary.

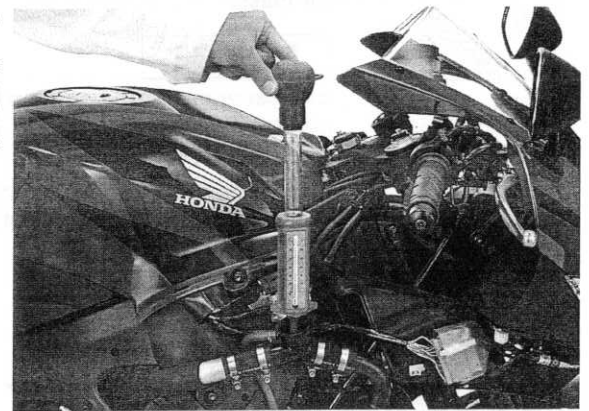

COOLANT GRAVITY CHART

		Coolant temperature °C (°F)										
		0 (32)	5 (41)	10 (50)	15 (59)	20 (68)	25 (77)	30 (86)	35 (95)	40 (104)	45 (113)	50 (122)
Coolant ratio%	5	1.009	1.009	1.008	1.008	1.007	1.006	1.005	1.003	1.001	0.999	0.997
	10	1.018	1.017	1.017	1.016	1.015	1.014	1.013	1.011	1.009	1.007	1.005
	15	1.028	1.027	1.026	1.025	1.024	1.022	1.020	1.018	1.016	1.014	1.012
	20	1.036	1.035	1.034	1.033	1.031	1.029	1.027	1.025	1.023	1.021	1.019
	25	1.045	1.044	1.043	1.042	1.040	1.038	1.036	1.034	1.031	1.028	1.025
	30	1.053	1.052	1.051	1.049	1.047	1.045	1.043	1.041	1.038	1.035	1.032
	35	1.063	1.062	1.060	1.058	1.056	1.054	1.052	1.049	1.046	1.043	1.040
	40	1.072	1.070	1.068	1.066	1.064	1.062	1.059	1.056	1.053	1.050	1.047
	45	1.080	1.078	1.076	1.074	1.072	1.069	1.066	1.063	1.060	1.057	1.054
	50	1.086	1.084	1.082	1.080	1.077	1.074	1.071	1.068	1.065	1.062	1.059
	55	1.095	1.093	1.091	1.088	1.085	1.082	1.079	1.076	1.073	1.070	1.067
60	1.100	1.098	1.095	1.092	1.089	1.086	1.083	1.080	1.077	1.074	1.071	

COOLING SYSTEM

RADIATOR CAP/SYSTEM PRESSURE INSPECTION

Remove the radiator cap (page 7-5).

Before installing the cap in the tester, wet the sealing surfaces.

Pressure test the radiator cap. Replace the radiator cap if it does not hold pressure, or if relief pressure is too high or too low. It must hold specified pressure for at least 6 seconds.

RADIATOR CAP RELIEF PRESSURE:

108 – 137 kPa (1.1 – 1.4 kgf/cm², 16 – 20 psi)

Pressure the radiator, engine and hoses, and check for leaks.

NOTICE

Excessive pressure can damage the cooling system components. Do not exceed 137 kPa (1.4 kgf/cm², 20 psi).

Repair or replace components if the system will not hold specified pressure for at least 6 seconds.

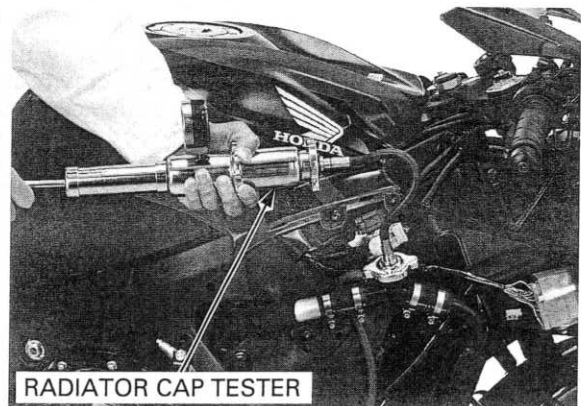
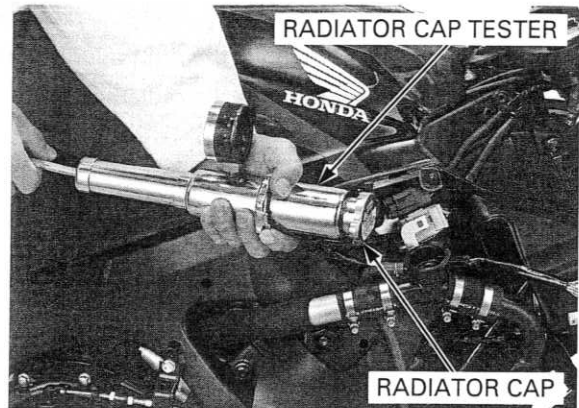

COOLANT REPLACEMENT

PREPARATION

- The effectiveness of coolant decreases with the accumulation of rust or if there is a change in the mixing proportion during usage. Therefore, for best performance change the coolant regularly as specified in the maintenance schedule.
- Mix only distilled, low mineral water with the antifreeze.

RECOMMENDED ANTIFREEZE:

Pro Honda HP Coolant or an equivalent high quality ethylene glycol antifreeze containing silicate free corrosion inhibitors

RECOMMENDED MIXTURE:

1:1 (mixture with distilled water)

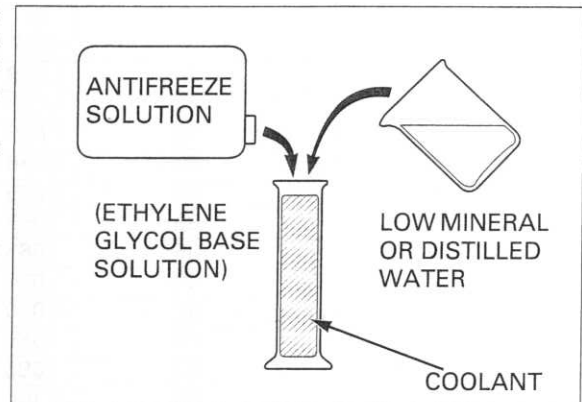

REPLACEMENT/AIR BLEEDING

When filling the system or reserve tank with a coolant (checking coolant level), place the motorcycle in a vertical position on a flat, level surface.

Remove the following:

- Right middle cowl (page 3-8)
- Lower cowl (page 3-6)

Remove the radiator cap (page 7-5).

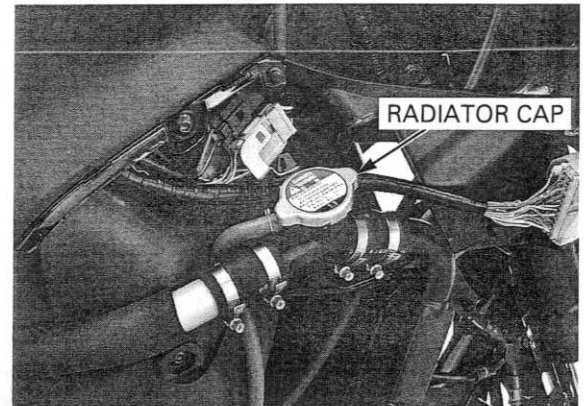

Remove the water pump drain bolt, sealing washer and drain the coolant.

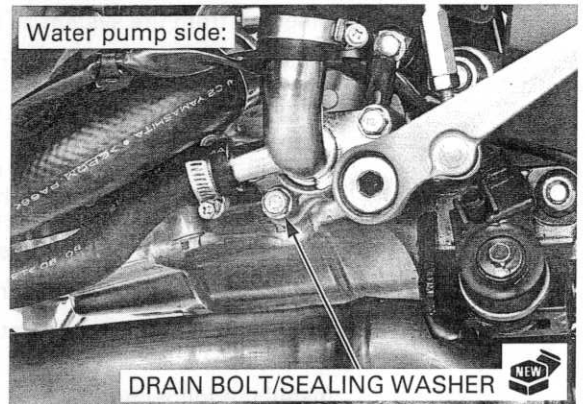

Remove the cylinder drain bolt and drain the coolant from the cylinder.

Reinstall the drain bolts with new sealing washers. Tighten the cylinder drain bolt securely. Tighten the water pump drain bolt to the specified torque.

TORQUE: 12 N·m (1.2 kgf·m, 9 lbf·ft)



Disconnect the siphon hose from the radiator reserve tank.

Drain the reserve tank coolant. Empty the coolant and rinse the inside of the reserve tank with water.

Connect the radiator siphon hose.

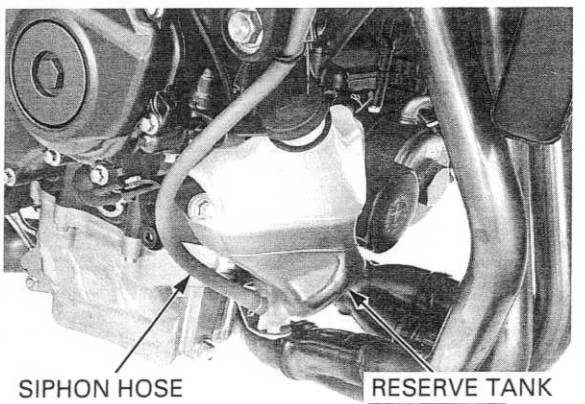

COOLING SYSTEM

Fill the system with the recommended coolant through the filler opening up to filler neck.

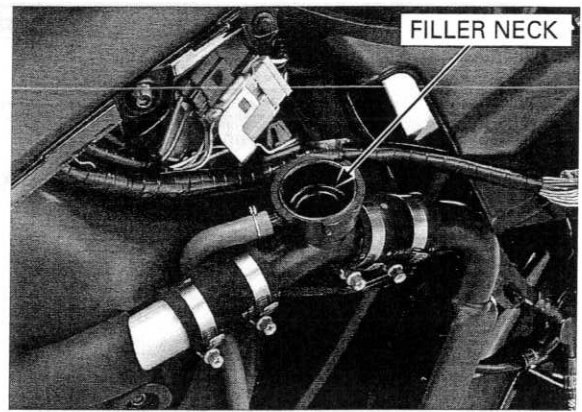

Remove the radiator reserve tank cap and fill the reserve tank to the upper level line.

Bleed air from the system as follows:

1. Shift the transmission into neutral. Start the engine and let it idle for 2 – 3 minutes.
2. Snap the throttle three or four times to bleed air from the system.
3. Stop the engine and add coolant up to the filler neck if necessary. Install the radiator cap.
4. Check the level of coolant in the reserve tank and fill to the upper level if it is low.

Install the radiator reserve tank cap.

After installation, check that there are no coolant leaks.

Install the following:

- Right middle cowl (page 3-8)
- Lower cowl (page 3-6)

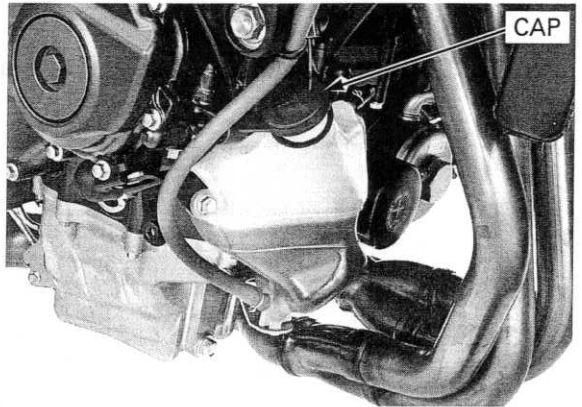

THERMOSTAT HOUSING

REMOVAL

Drain the coolant (page 7-7).

Remove the throttle body (page 6-60).

Remove the bolts and thermostat housing cover.

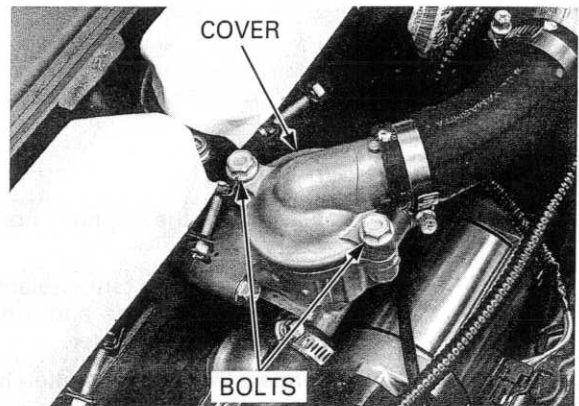

Remove the thermostat from the housing.
 Disconnect the ECT sensor 3P (Gray) connector.
 Loosen the hose clamp screw and disconnect the water hose.

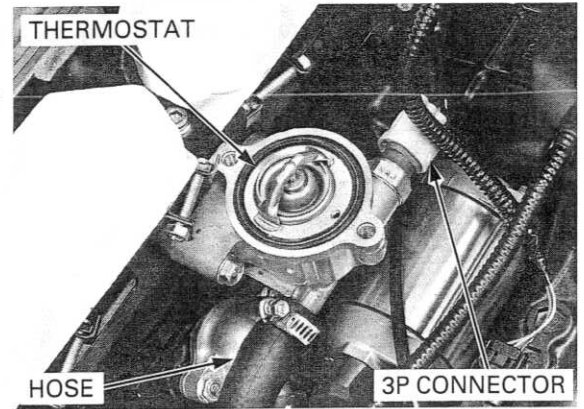

Remove the bolts, thermostat housing and O-ring from the cylinder head.

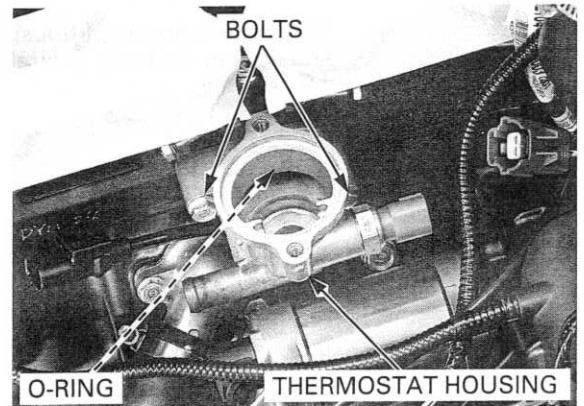

INSPECTION

Visually inspect the thermostat for damage.
 Check for damage of the seal ring.

Wear insulated gloves and adequate eye protection.
 Keep flammable materials away from the electric heating element.

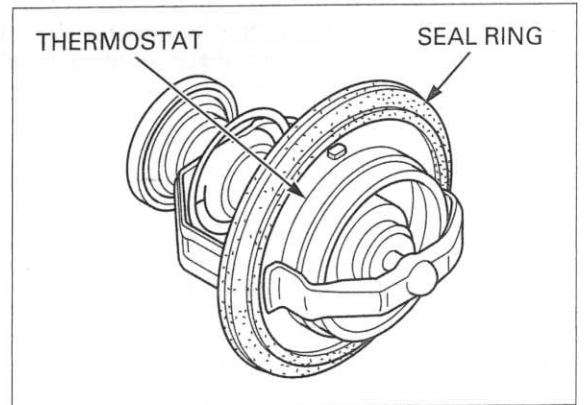

Do not let the thermostat or thermometer touch the pan, or you will get false reading.

Heat the water with an electric heating element to operating temperature for 5 minutes.
 Suspend the thermostat in heated water to check its operation.

Replace the thermostat if the valve stays open at room temperature, or if it responds at temperatures other than those specified.

THERMOSTAT BEGIN TO OPEN:

80 – 84°C (176 – 183°F)

VALVE LIFT:

8 mm (0.3 in) minimum at 95°C (203°F)

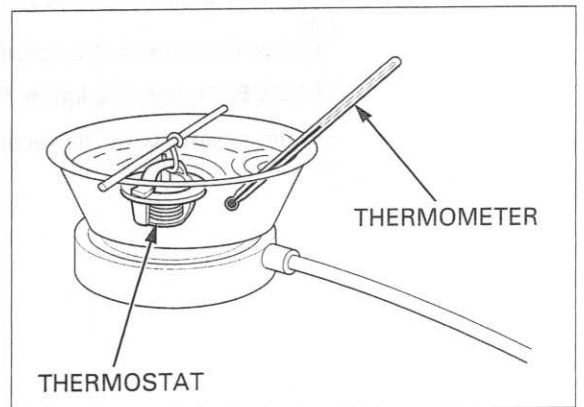

COOLING SYSTEM

INSTALLATION

Install a new O-ring to the thermostat housing groove.

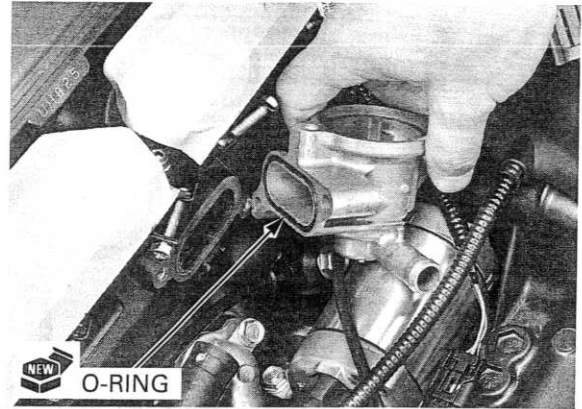

Install the thermostat housing to the cylinder head and tighten the bolts securely.

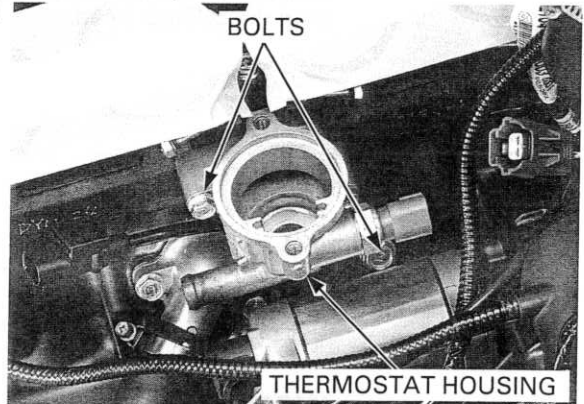

Connect the ECT sensor 3P (Gray) connector.
Install the thermostat into the housing by aligning the thermostat air bleed hole with the housing boss.

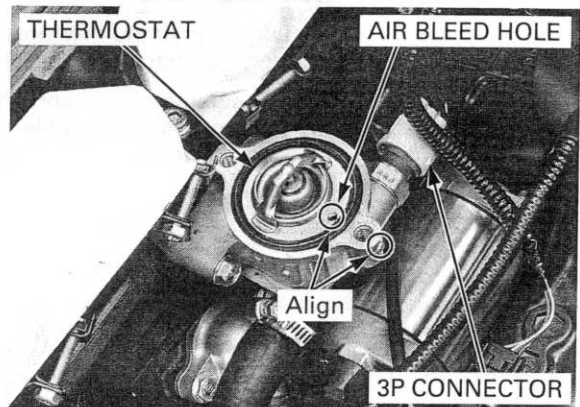

Install the thermostat housing cover onto the housing.
Tighten the bolts to the specified torque.

TORQUE: 12 N·m (1.2 kgf·m, 9 lbf·ft)

Fill the system with the recommended coolant and bleed any air (page 7-6).

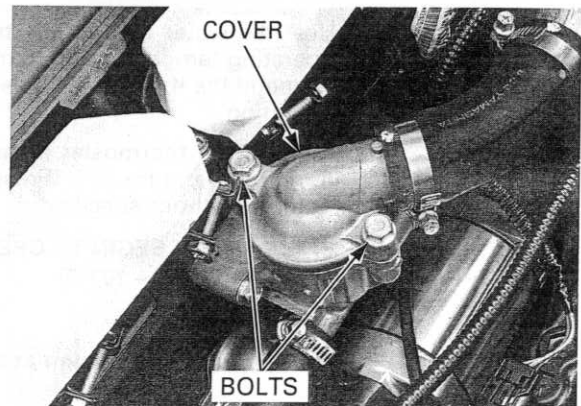

RADIATOR

REMOVAL

Remove the following:

- Lower cowl (page 3-6)
- Middle cowls (page 3-8)

Drain the coolant (page 7-7).

Disconnect the fan motor 2P (Black) connector.

Remove the horn wire clamp from the left heat guard plate.

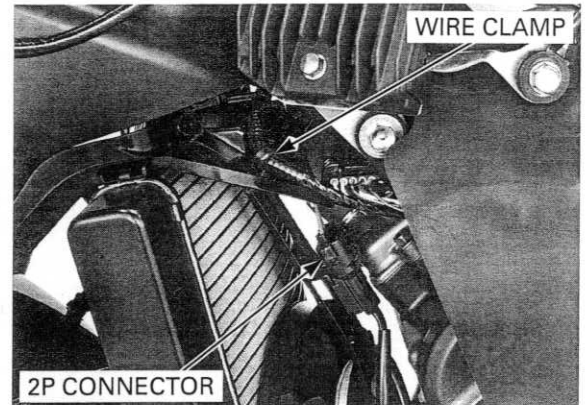

Remove the radiator lower mounting bolt, washer and nut.

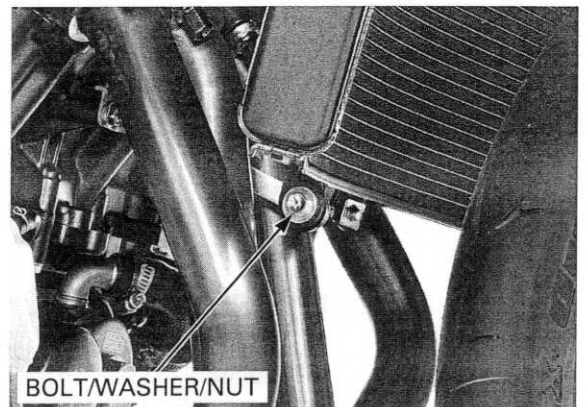

Remove the radiator upper mounting bolt and washer.

Be careful not to damage the radiator fins.

Release the radiator upper grommet from the frame boss.

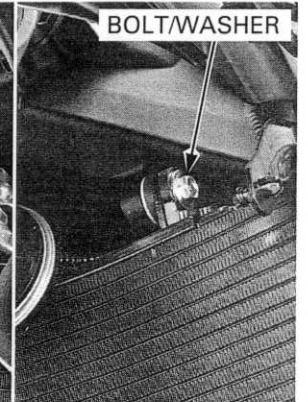
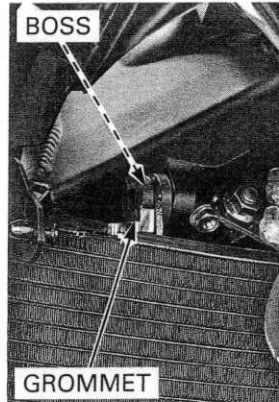

Loosen the hose clamp screw and disconnect the left radiator hose.

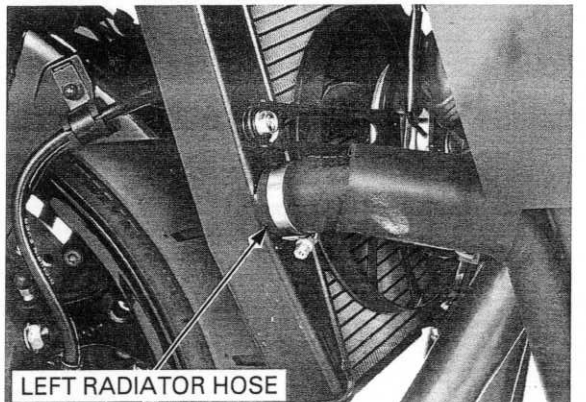

COOLING SYSTEM

Loosen the hose clamp screw and disconnect the right radiator hose.

Remove the radiator to the right side.

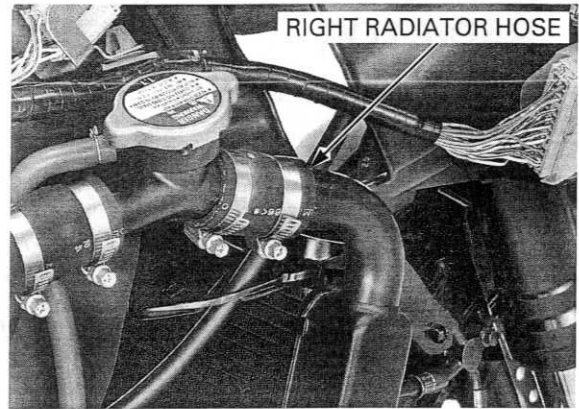

Be careful not to damage the radiator fins.

Remove the trim clip and right heat guard plate from the radiator.

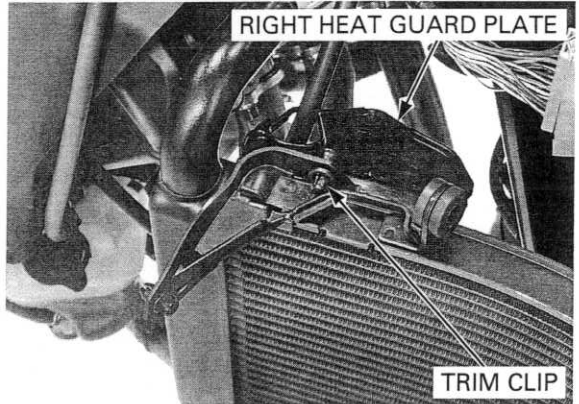

DISASSEMBLY

Remove the trim clip and left heat guard plate from the radiator.

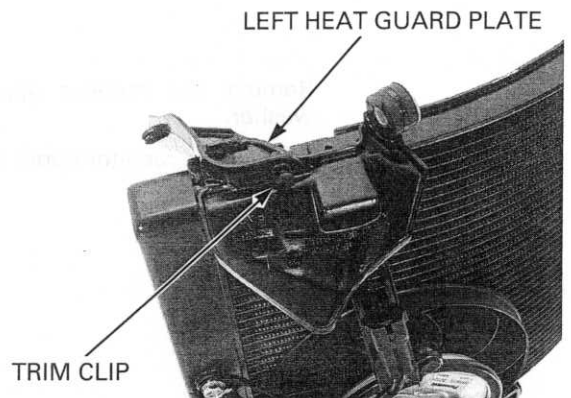

Remove the bolts and fan motor assembly from the radiator.

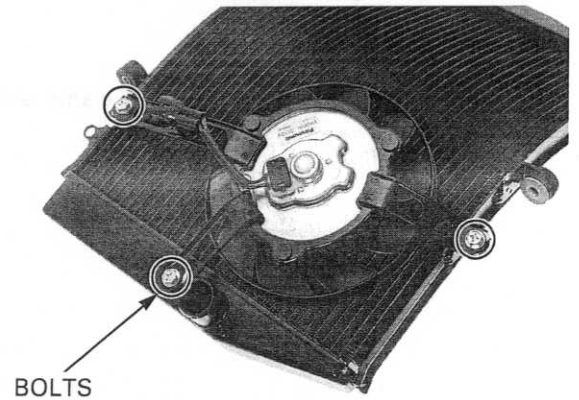

Remove the nut and cooling fan.

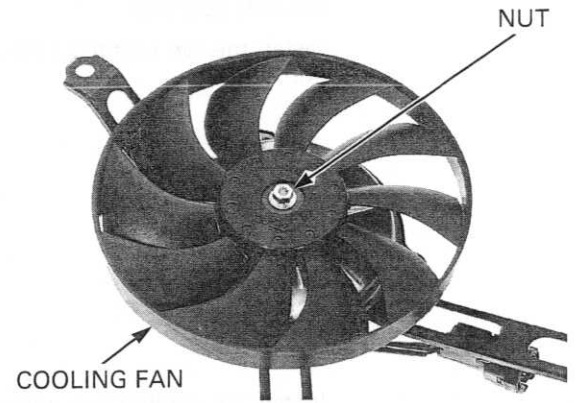

Release the fan motor 2P (Black) connector from the shroud.

Remove the nuts and fan motor from the shroud.

For fan motor relay information (page 7-20).

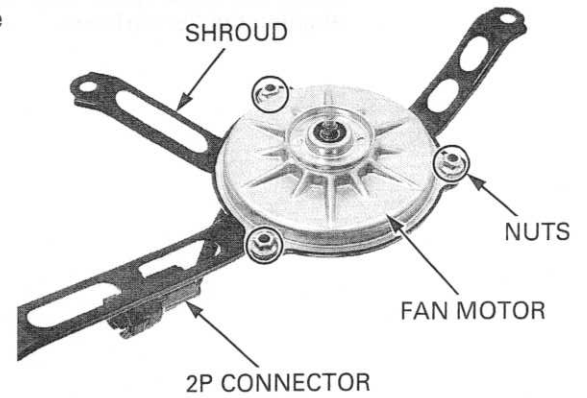

ASSEMBLY

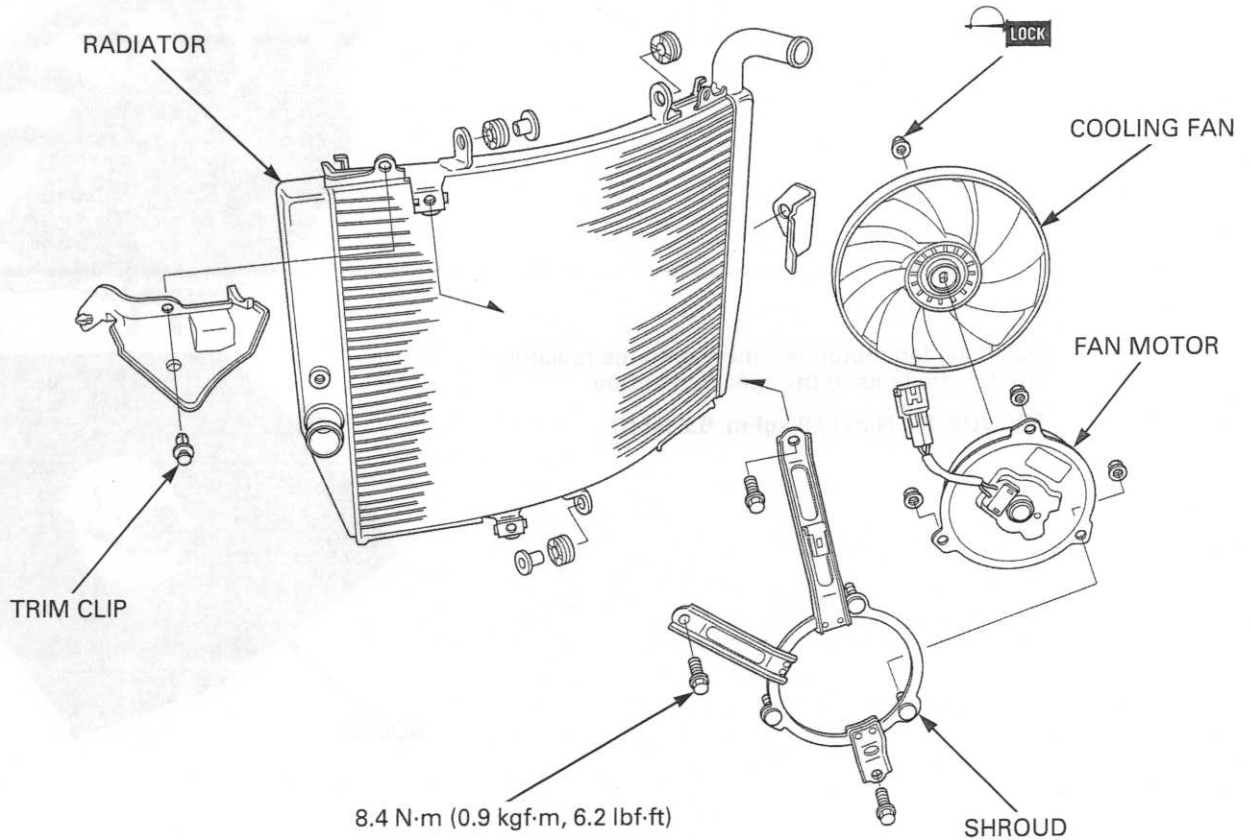

COOLING SYSTEM

Install the fan motor onto the shroud and tighten the nuts securely.

Install the fan motor 2P (Black) connector onto the shroud.

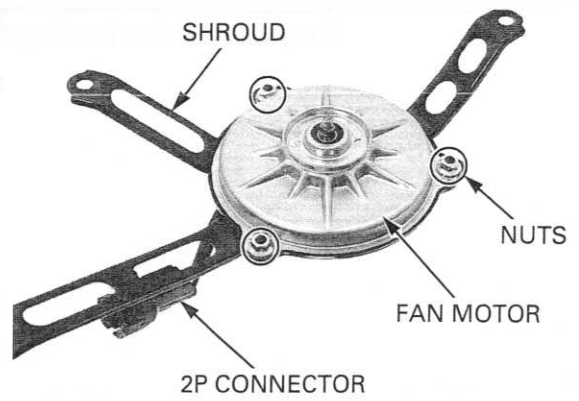

Install the cooling fan onto the fan motor shaft by aligning the flat surfaces.

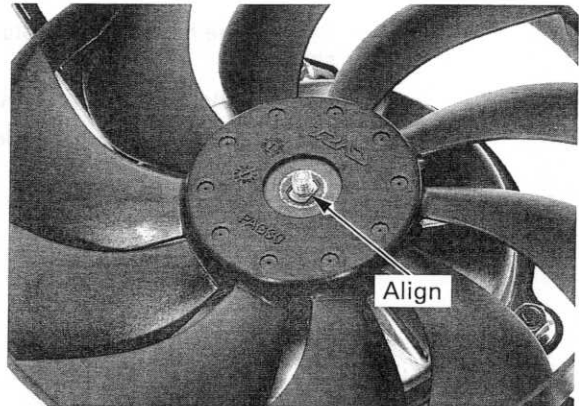

Apply locking agent to the cooling fan nut threads.
Tighten the nut securely.

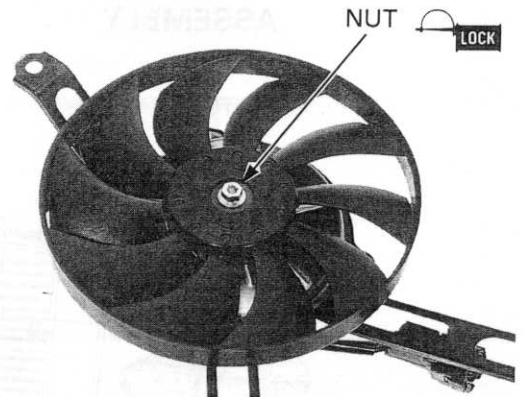

Install the fan motor assembly onto the radiator.
Tighten the bolts to the specified torque.

TORQUE: 8.4 N·m (0.9 kgf·m, 6.2 lbf·ft)

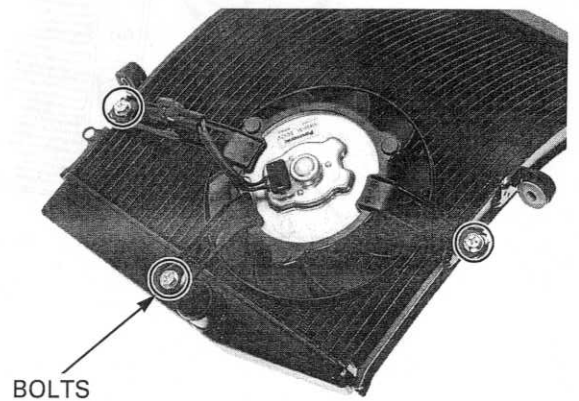

Install the left heat guard plate and trim clip onto the radiator left side.

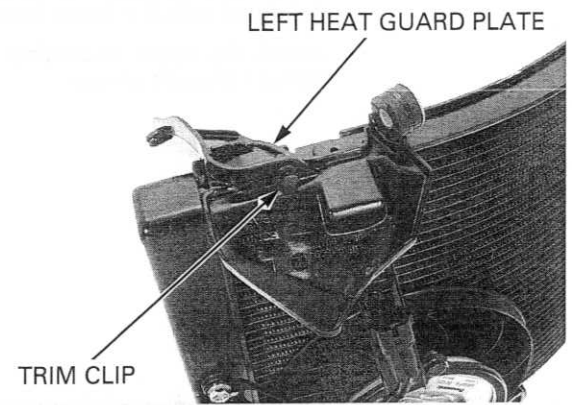

INSTALLATION

Be careful not to damage the radiator fins.

Install the right heat guard plate and trim clip onto the radiator right side.

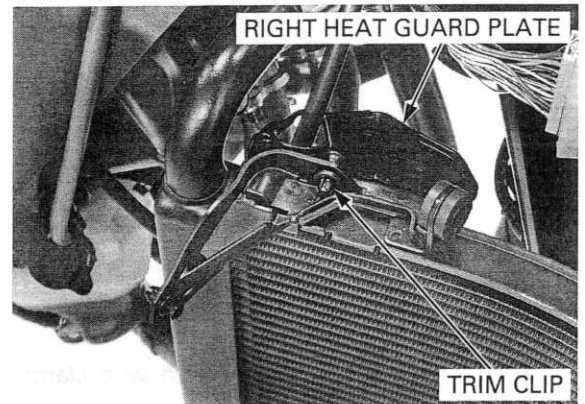

Connect the right radiator hose and tighten the hose clamp screw securely (page 7-19).

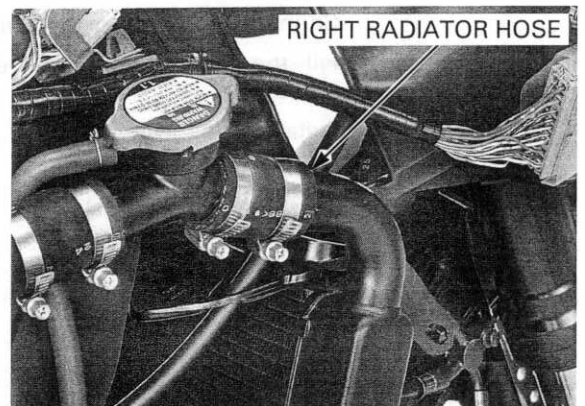

Connect the left radiator hose and tighten the hose clamp screw securely (page 7-19).

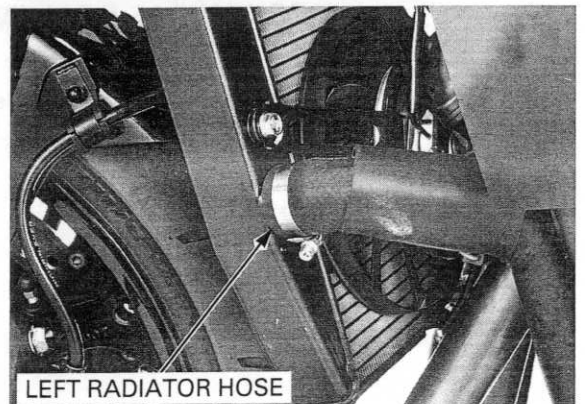

COOLING SYSTEM

Install the radiator assembly, aligning its upper grommet with the frame boss.

Install the upper mounting bolt and washer, then tighten the bolt securely.

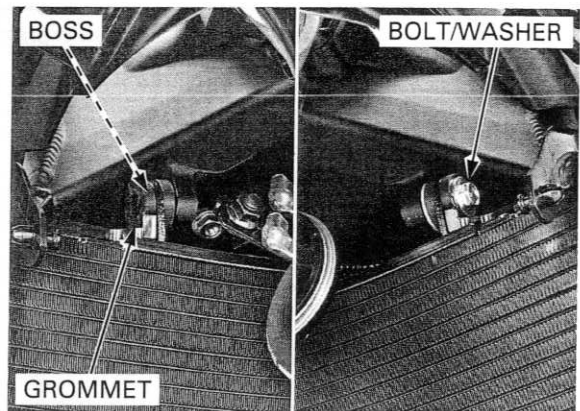

Install the radiator lower mounting bolt, washer, nut and tighten the nut securely.

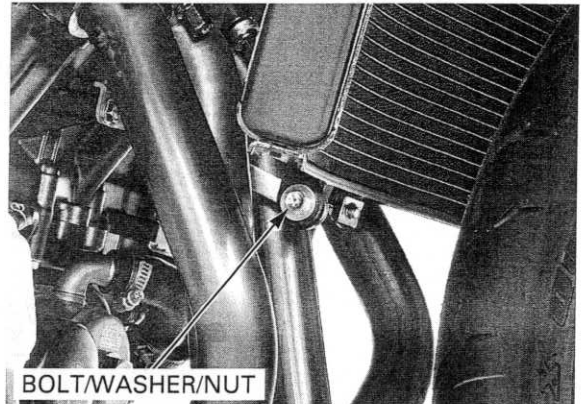

Install the horn wire clamp to the left heat guard plate.

Connect the fan motor 2P (Black) connector.

Fill the system with the recommended coolant (page 7-6).

Install the following:

- Middle cowls (page 3-8)
- Lower cowl (page 3-6)

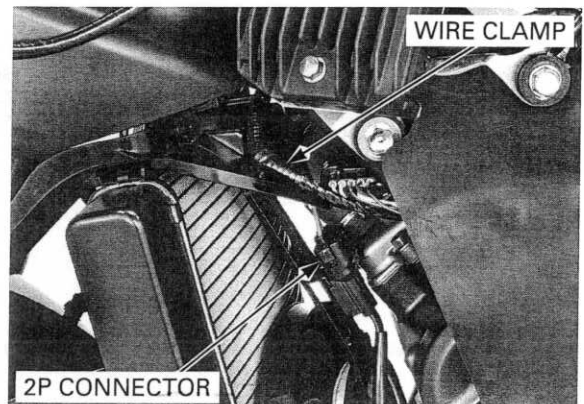

WATER PUMP

MECHANICAL SEAL INSPECTION

Remove the lower cowl (page 3-6).

Check for signs of seal leakage.

A small amount of "weeping" from the bleed hole is normal.

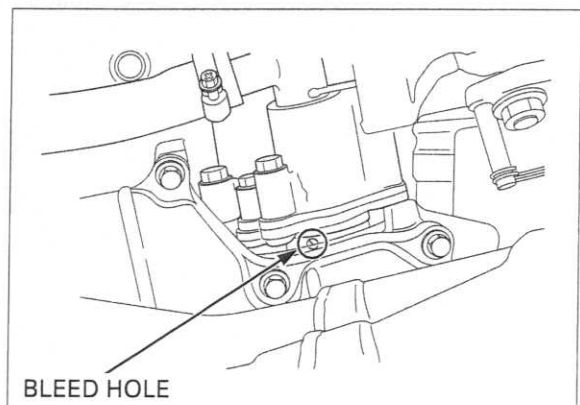

REMOVAL

Remove the following:

- Lower cowl (page 3-6)
- Gearshift arm (page 8-4)
- Drive sprocket cover (page 8-5)

Drain the coolant (page 7-7).

Loosen the hose clamp screws and disconnect the hoses.

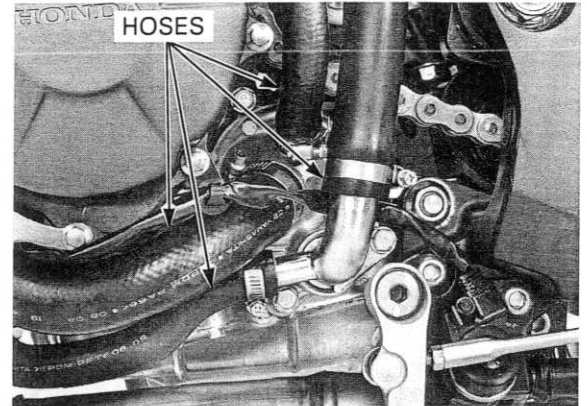

Remove the bolt, joint pipe and O-ring.

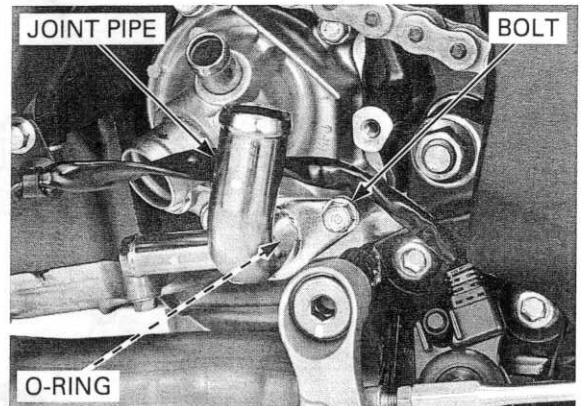

Remove the bolts and water pump cover.

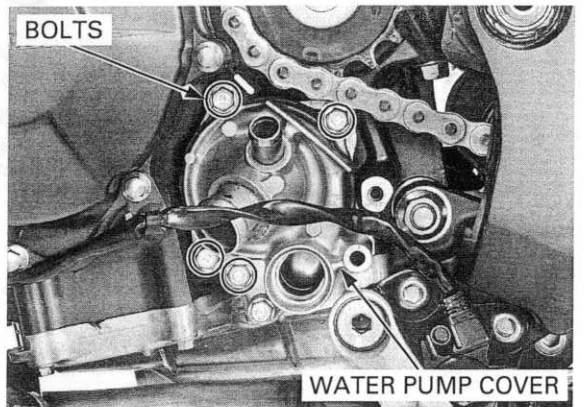

Remove the O-ring from the water pump body.

Do not disassemble the water pump body.

Remove the water pump body and O-ring from the crankcase.

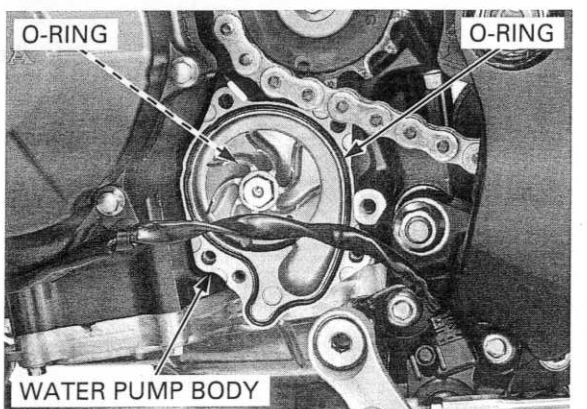

COOLING SYSTEM

INSTALLATION

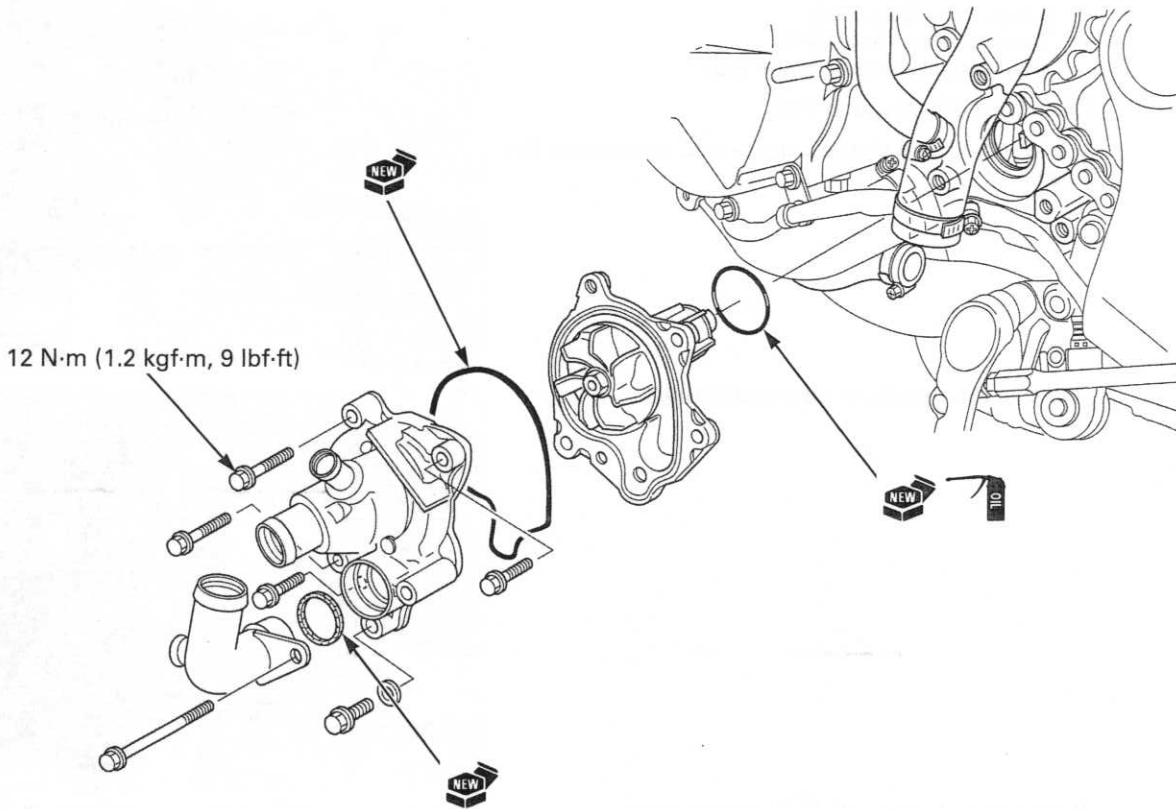

Apply oil to a new O-ring and install it onto the stepped portion of the water pump body.

Install the water pump body into the crankcase while aligning the water pump shaft groove with the oil pump shaft end by turning the water pump impeller.

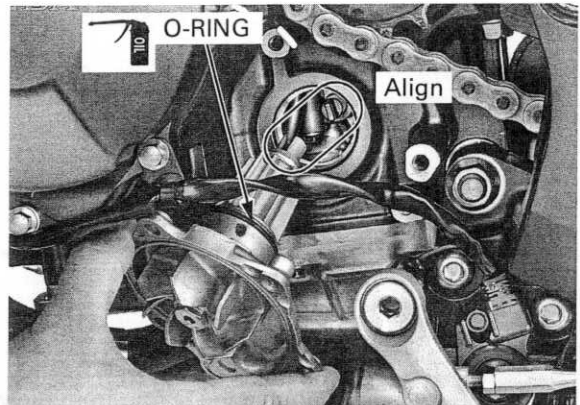

Install a new O-ring into the groove in the water pump body.

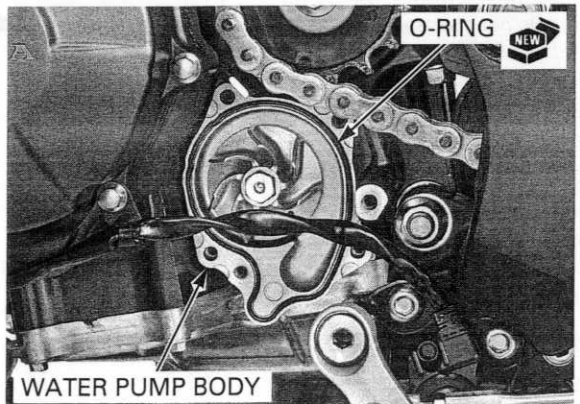

Install the water pump cover and bolts.
Tighten the bolts to the specified torque.

TORQUE: 12 N·m (1.2 kgf·m, 9 lbf·ft)

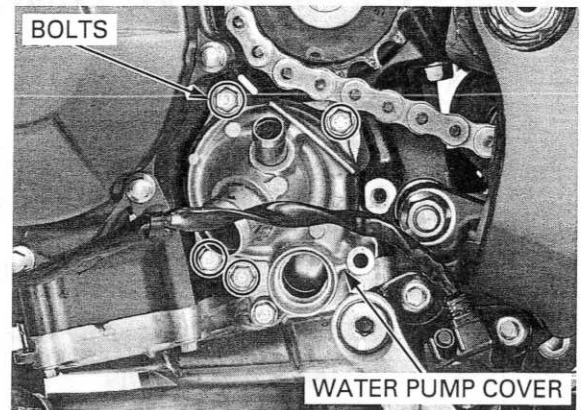

Install a new O-ring to the joint pipe.

Install the joint pipe to the water pump cover and tighten the bolt securely.

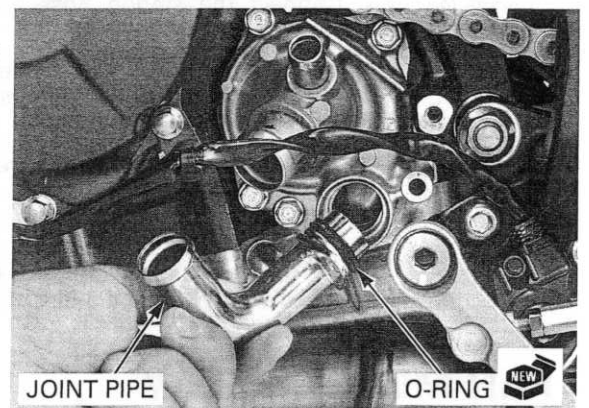

Connect the hoses and tighten the hose clamp screws.

Fill the system with the recommended coolant (page 7-6).

Start the engine and check for coolant leaks.

Install the following:

- Drive sprocket cover (page 8-15)
- Gearshift arm (page 8-15)
- Lower cowl (page 3-6)

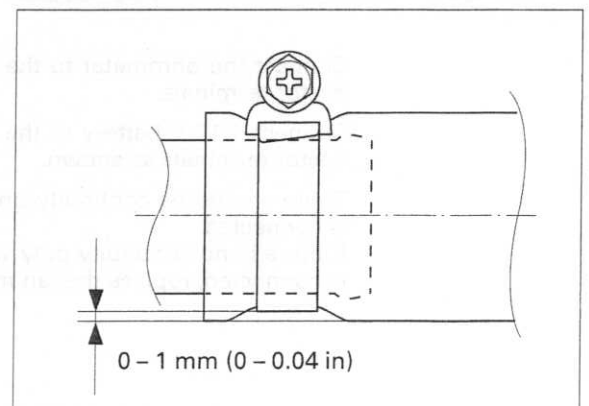
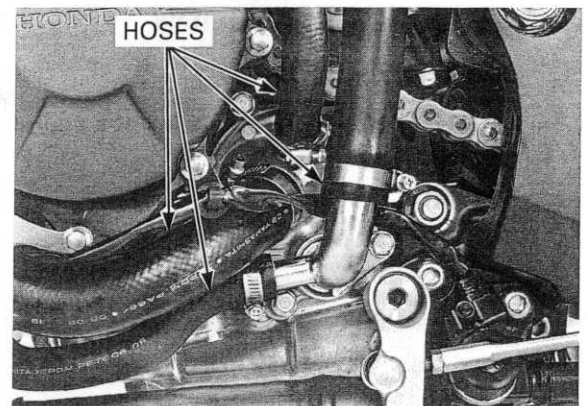

COOLING SYSTEM

RADIATOR RESERVE TANK

REMOVAL

Remove the following:

- Lower cowl (page 3-6)
- Right middle cowl (page 3-8)

Disconnect the siphon hose and drain the coolant from the reserve tank.

Disconnect the coolant over flow hose from the reserve tank.

Remove the bolt and radiator reserve tank.

INSTALLATION

Route the hoses properly (page 1-21).

Connect the siphon hose and coolant over flow hose to the reserve tank.

Install the reserve tank while aligning the reserve tank boss with the mounting stay hole. Tighten the bolt securely.

Fill the system with the recommended coolant (page 7-6).

Install the following:

- Right middle cowl (page 3-8)
- Lower cowl (page 3-6)

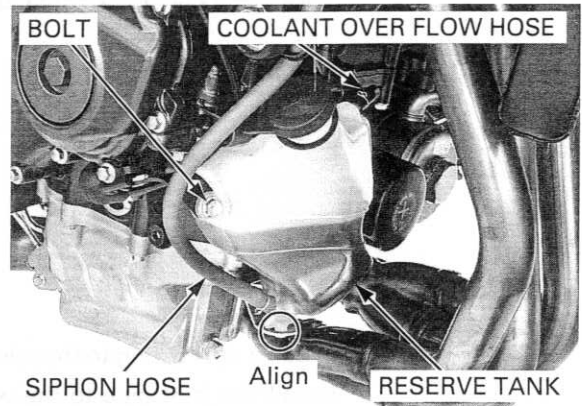

FAN MOTOR RELAY

INSPECTION

Remove the seat (page 3-4).

Open the fuse/relay box and remove the fan motor relay.



Connect the ohmmeter to the fan motor relay connector terminals.

Connect a 12 V battery to the fan motor relay connector terminals as shown.

There should be continuity only when 12 V battery is connected.

If there is no continuity only when the 12 V battery is connected, replace the fan motor relay.

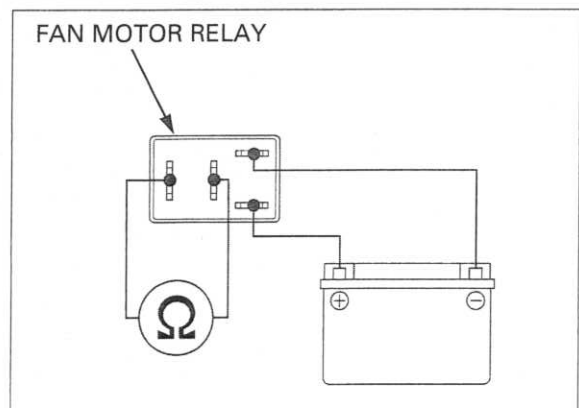

8. ENGINE REMOVAL/INSTALLATION

COMPONENT LOCATION	8-2	ENGINE REMOVAL	8-4
SERVICE INFORMATION	8-3	ENGINE INSTALLATION.....	8-9

ENGINE REMOVAL/INSTALLATION

COMPONENT LOCATION

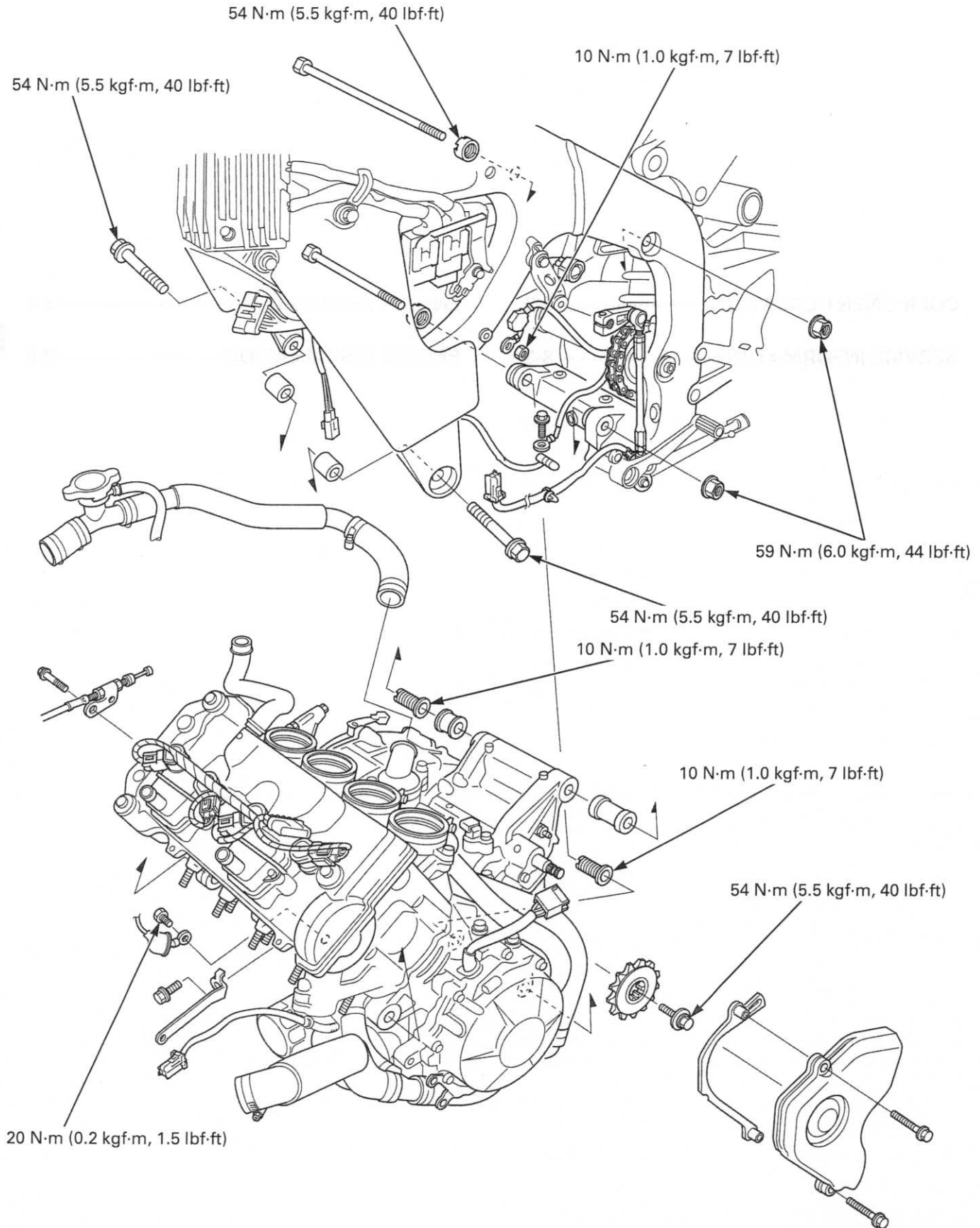

SERVICE INFORMATION

GENERAL

- A hoist or equivalent is required to support the motorcycle when removing and installing the engine.
- A floor jack or other adjustable support is required to support and maneuver the engine.
- Do not use the oil filter and oil cooler as a jacking point.
- When using the lock nut wrench for the engine hanger lock nut, use a deflecting beam type torque wrench 20 inches long. The lock nut wrench increases the torque wrench's leverage, so the torque wrench reading will be less than the torque actually applied to the lock nut. The specification given is the actual torque applied to the lock nut, not the reading on the torque wrench. Do not overtighten the lock nut. The specification later in the text gives both actual and indicated.
- The following components can be serviced with the engine installed in the frame.
 - Alternator (page 11-4)
 - Clutch (page 10-7)
 - Camshaft (page 9-9)
 - Cylinder head (page 9-14)
 - Gearshift linkage (page 10-23)
 - Oil cooler (page 5-13)
 - Oil pump (page 5-7)
 - Water pump (page 7-16)
- The following components require engine removal for service.
 - Crankshaft (page 13-5)
 - Piston/cylinder (page 13-14)
 - Shift fork/shift drum/transmission (page 12-6)
- When installing the engine, be sure to tighten the engine mounting fasteners to the specified torque in the specified sequence. If you mistake the torque or sequence, loosen all mounting fasteners, then tighten them again to the specified torque in the correct sequence.

SERVICE DATA

ITEM	SPECIFICATIONS
Engine dry weight	57 kg (126 lbs)
Engine oil capacity (After disassembly)	3.5 liter (3.7 US qt, 3.1 Imp qt)
Coolant capacity (Radiator and engine)	3.15 liter (3.33 US qt, 2.77 Imp qt)

TORQUE VALUES

Front engine hanger bolt	54 N·m (5.5 kgf·m, 40 lbf·ft)
Upper engine hanger adjusting bolt	10 N·m (1.0 kgf·m, 7 lbf·ft)
Upper engine hanger lock nut	54 N·m (5.5 kgf·m, 40 lbf·ft)
Upper engine hanger nut	59 N·m (6.0 kgf·m, 44 lbf·ft)
Lower engine hanger adjusting bolt	10 N·m (1.0 kgf·m, 7 lbf·ft)
Lower engine hanger lock nut	54 N·m (5.5 kgf·m, 40 lbf·ft)
Lower engine hanger nut	59 N·m (6.0 kgf·m, 44 lbf·ft)
Drive sprocket bolt	54 N·m (5.5 kgf·m, 40 lbf·ft)
Starter motor terminal nut	10 N·m (1.0 kgf·m, 7 lbf·ft)
EOP switch wire terminal bolt	2.0 N·m (0.2 kgf·m, 1.5 lbf·ft)

TOOL

Lock nut wrench
07VMA-MBB0100

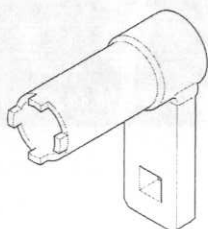

ENGINE REMOVAL/INSTALLATION

ENGINE REMOVAL

Remove the following:

- Lower cowl (page 3-6)
- Middle cowls (page 3-8)
- Exhaust pipe (page 3-24)
- Radiator (page 7-11)
- Radiator reserve tank (page 7-20)
- Engine guard rubber (page 6-51)
- Throttle body (page 6-60)
- PAIR control solenoid valve (page 6-78)
- With the ignition switch OFF, disconnect the battery negative (-) cable (page 17-6).

Disconnect the alternator 3P (Natural), sidestand switch 2P (Green) and CMP sensor 2P (Black) connectors.

Disconnect the ignition sub harness 6P (Black) connector.

Remove the sidestand switch wire from the wire clamps.

Remove the bolt and gearshift arm from the gearshift spindle.

Disconnect the neutral switch connector.

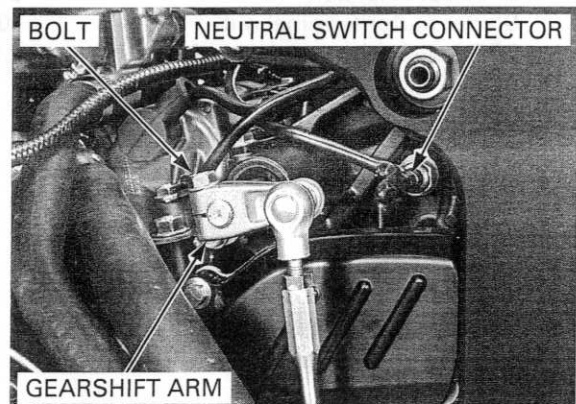
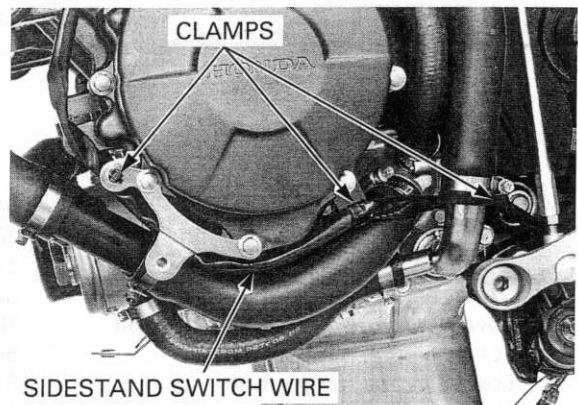
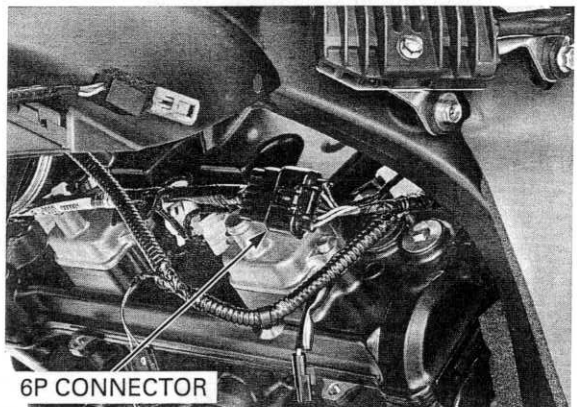
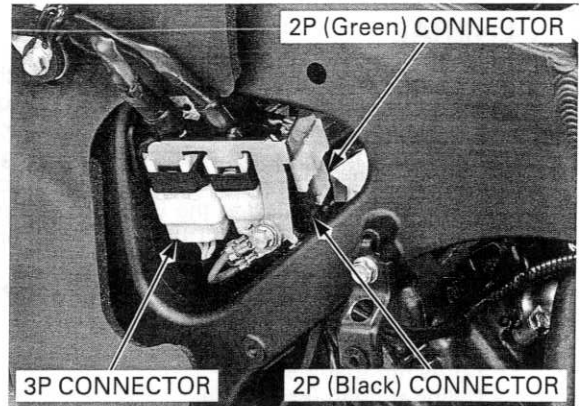

ENGINE REMOVAL/INSTALLATION

Remove the bolts, wire clamp, drive sprocket cover and guide plate.

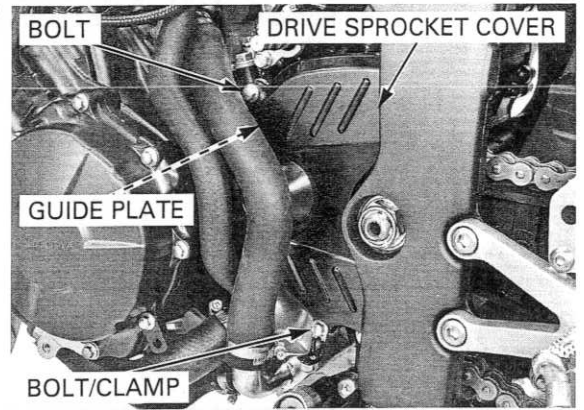

Loosen the rear axle nut.
Turn the drive chain adjusting bolts and make the drive chain slack fully (page 4-24).

Remove the bolt, washer and drive sprocket.

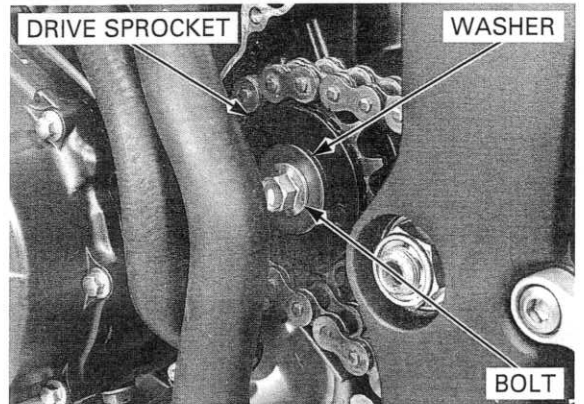

Disconnect the CKP sensor 2P (Black) connector.



Disconnect the joint hose and ECT sensor 3P (Gray) connector.

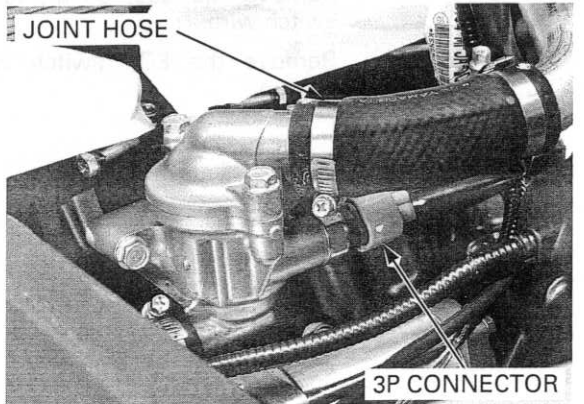

ENGINE REMOVAL/INSTALLATION

Remove the bolt and disconnect the ground cable.
Remove the nut and disconnect the starter motor cable.

Disconnect the VS sensor 3P (Black) connector.

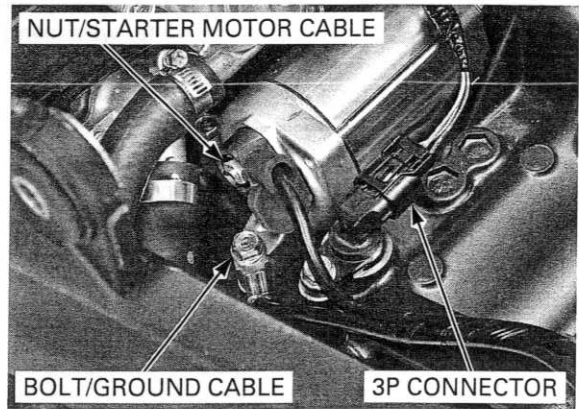

Disconnect the water hoses from the engine.

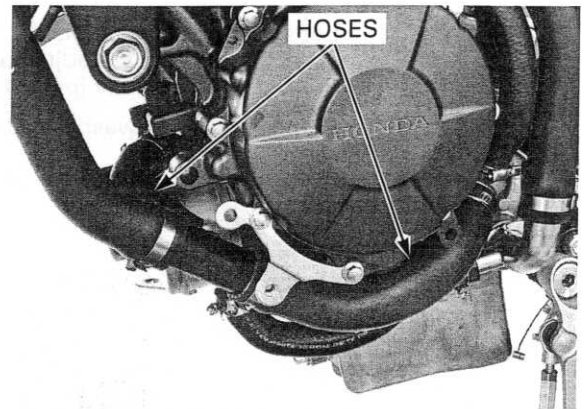

Remove the bolt and radiator bracket.

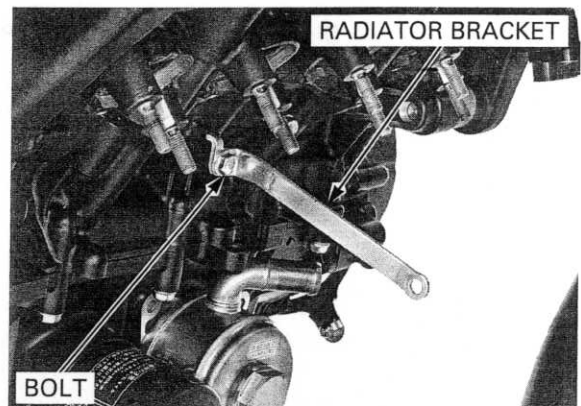

Remove the dust cover, terminal bolt and EOP switch wire.

Remove the EOP switch wire clamp from the engine.

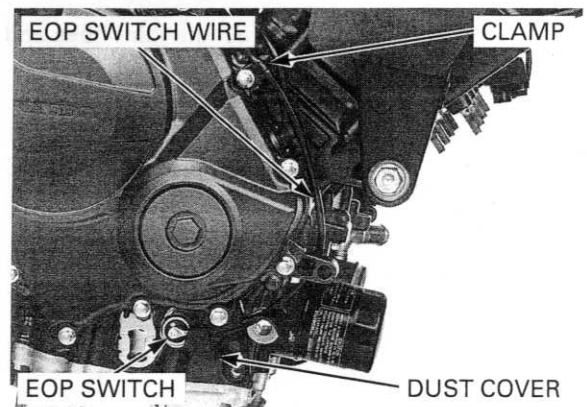

ENGINE REMOVAL/INSTALLATION

Remove the bolt and clutch cable guide plate, then disconnect the clutch cable end from the clutch lifter lever.

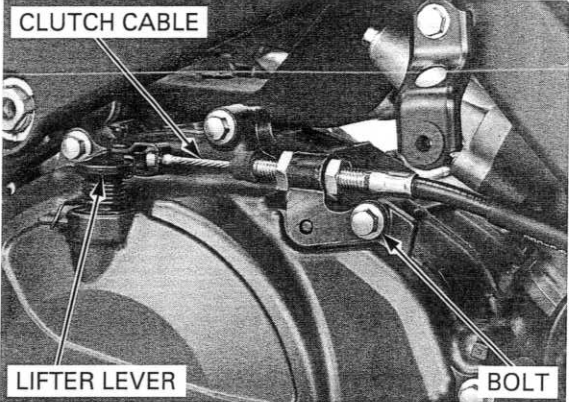

Support the engine using a jack or other adjustable support.
Remove the right front engine hanger bolt and collar.

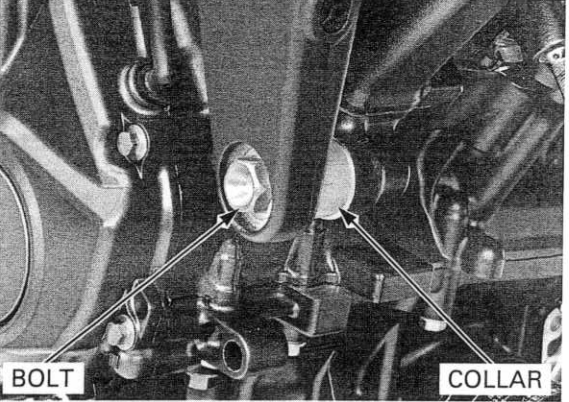

Remove the left front engine hanger bolt and collar.

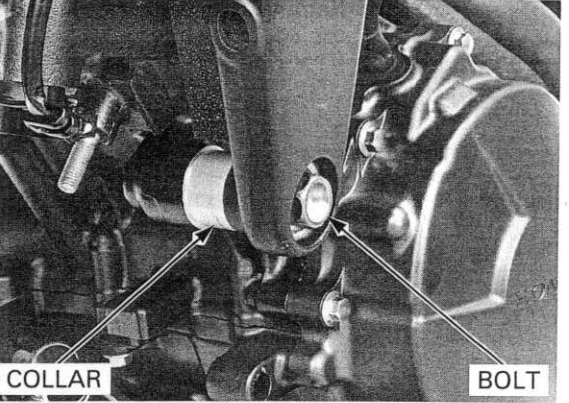

Remove the upper engine hanger nut while holding the engine hanger bolt.

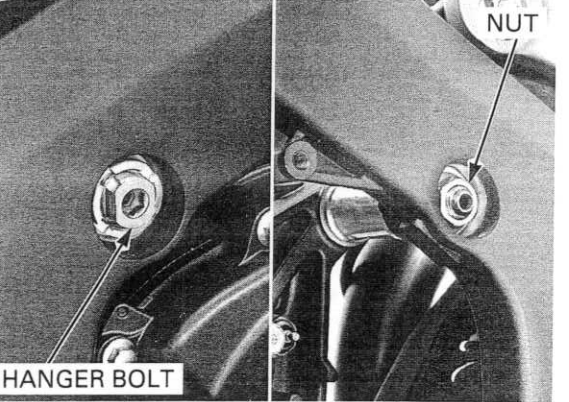

ENGINE REMOVAL/INSTALLATION

Loosen the upper engine hanger lock nut using the special tool.

TOOL:

Lock nut wrench

07VMA-MBB0100

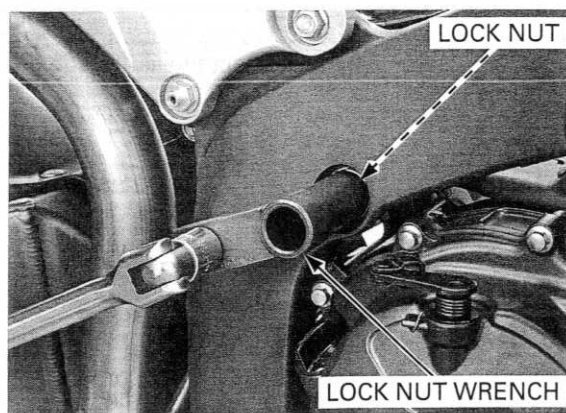

Turn the upper engine hanger adjusting bolt counterclockwise fully by turning the upper engine hanger bolt.

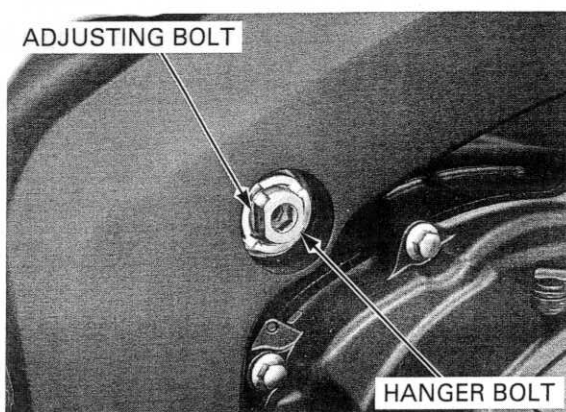

Remove the lower engine hanger nut while holding the engine hanger bolt.

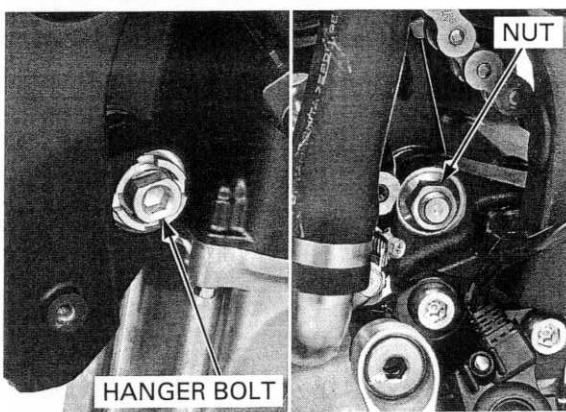

Loosen the lower engine hanger lock nut using the special tool.

TOOL:

Lock nut wrench

07VMA-MBB0100

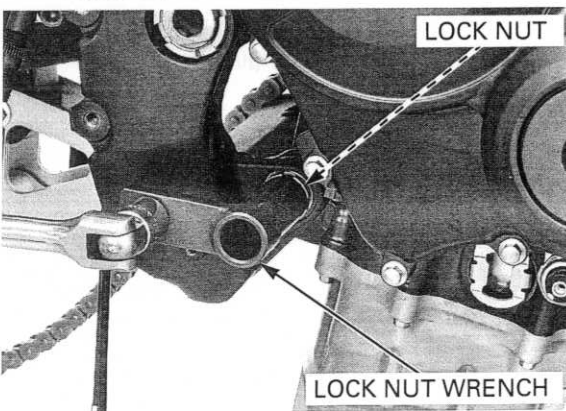

Turn the lower engine hanger adjusting bolt counterclockwise fully by turning the lower engine hanger bolt.

Support the engine using a jack or other adjustable support to ease removal of the engine hanger bolts.

Remove the following:

- Lower engine hanger bolt
- Upper engine hanger bolt and collars

Carefully lower the adjustable support, then remove the engine from the frame.

Remove the engine hanger lock nuts and adjusting bolts.

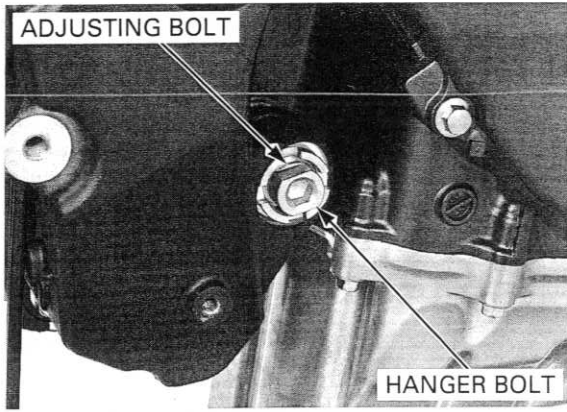

ENGINE INSTALLATION

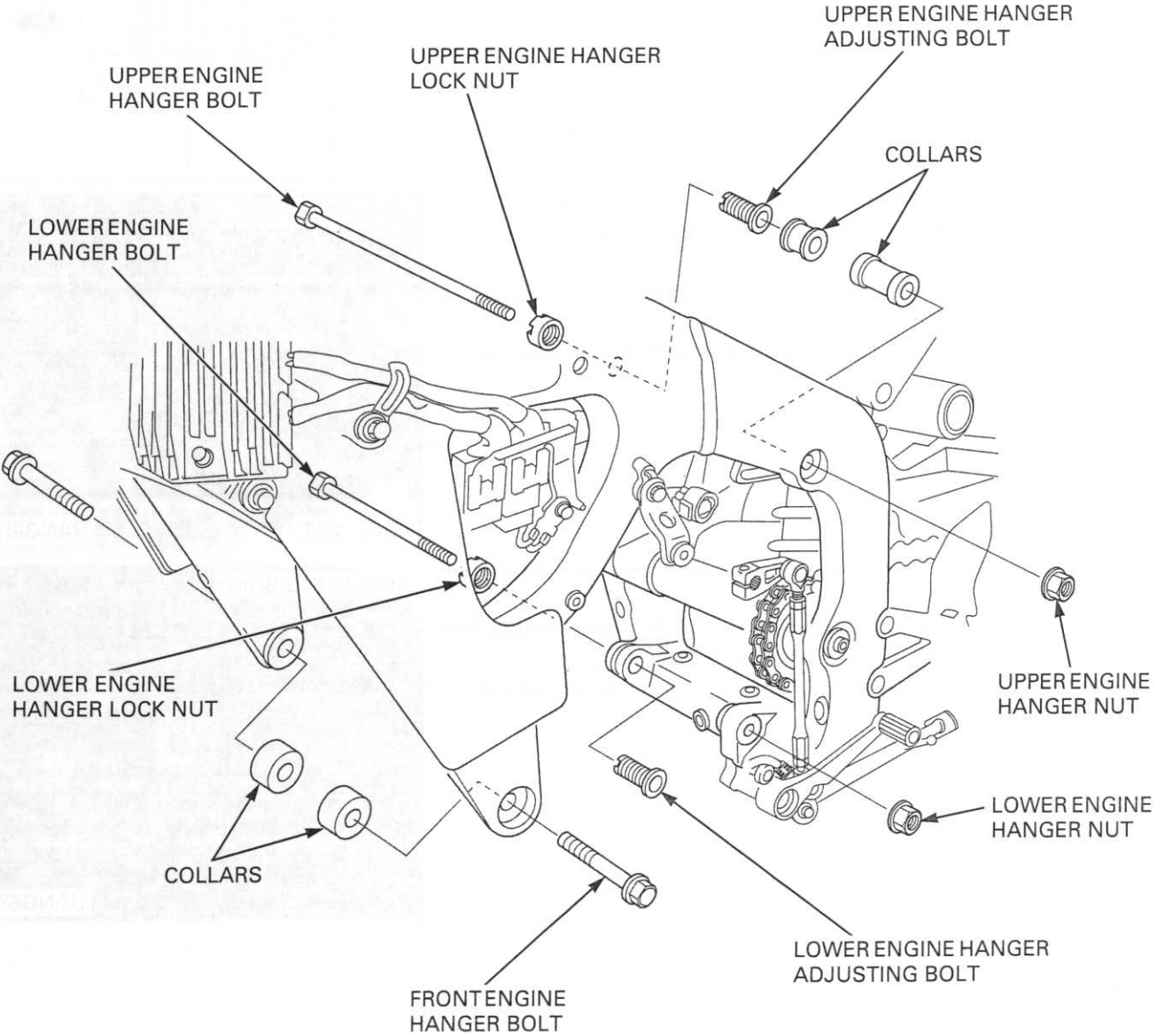

ENGINE REMOVAL/INSTALLATION

- Note the direction of the hanger bolts/collars.
- When tightening the lock nut with the lock nut wrench, refer to the torque wrench reading information in "SERVICE INFORMATION" (page 8-3).
- The jack height must be continually adjusted to relieve stress from the mounting fasteners.
- Route the wires, hoses and cables properly (page 1-21).
- Be sure to tighten all engine mounting fasteners to the specified torque in the specified sequence described on the following pages. If you mistake the tightening torque or sequence, loosen all mounting fasteners, then tighten them again to the specified torque in the specified sequence.

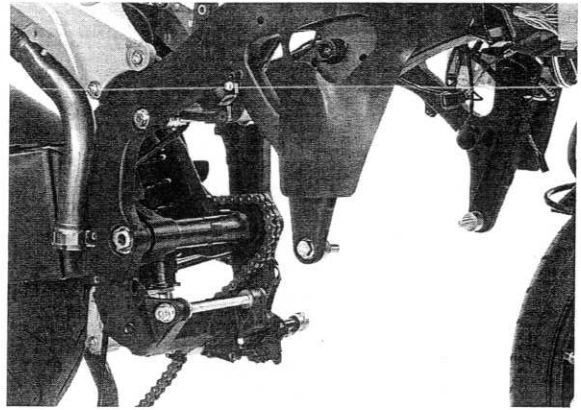

Install the upper and lower engine hanger adjusting bolts fully from the inside of the frame.

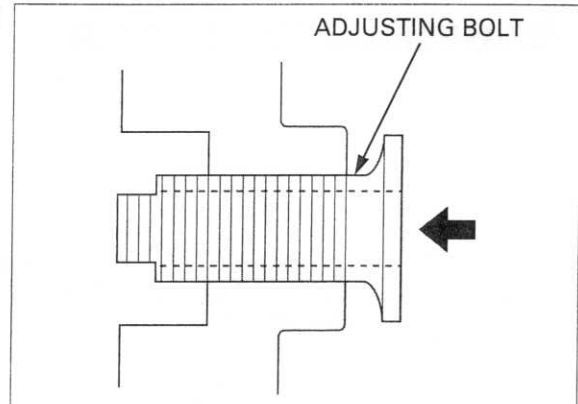

Carefully install the engine into the frame.

Install the lower engine hanger bolt from the right side.

Align the straight portion of the engine hanger bolt head with the adjusting bolt boss.

Loosely install the lower engine hanger lock nut.

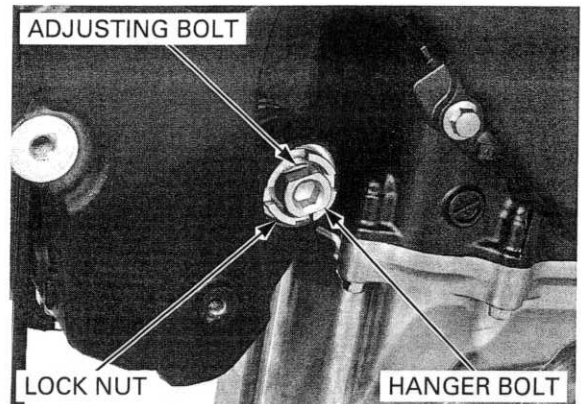

Install the collars and upper engine hanger bolt from the right side.

Align the straight portion of the engine hanger bolt head with the adjusting bolt boss.

Loosely install the upper engine hanger lock nut.

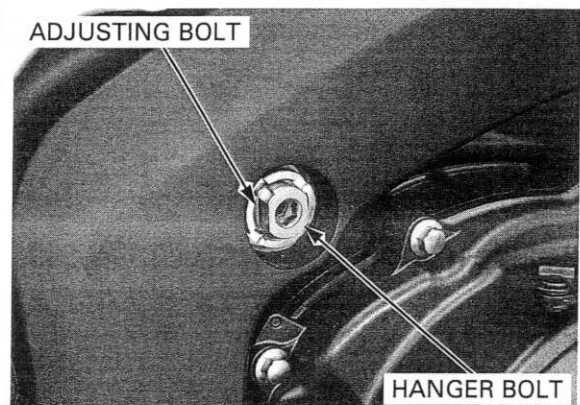

ENGINE REMOVAL/INSTALLATION

Loosely install the collar and left front engine hanger bolt.

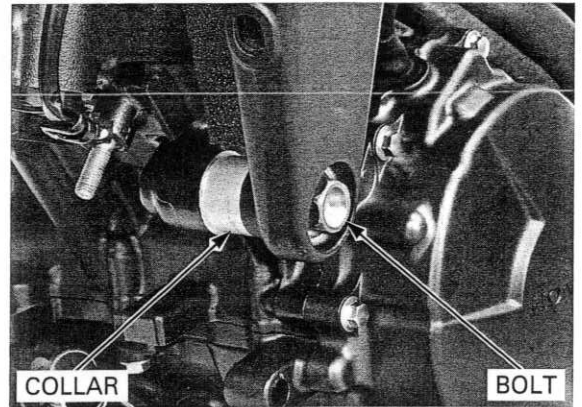

Loosely install the collar and right front engine hanger bolt.

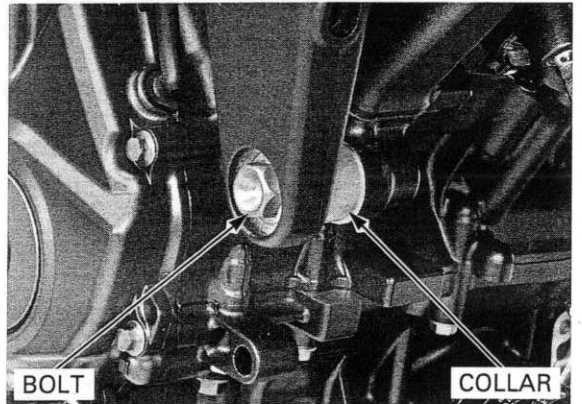

Turn the upper and lower engine hanger adjusting bolt by turning the hanger bolt until the adjusting bolt is seated on the engine.

Tighten the lower engine hanger adjusting bolt to the specified torque by turning the lower engine hanger bolt.

TORQUE: 10 N·m (1.0 kgf·m, 7 lbf·ft)

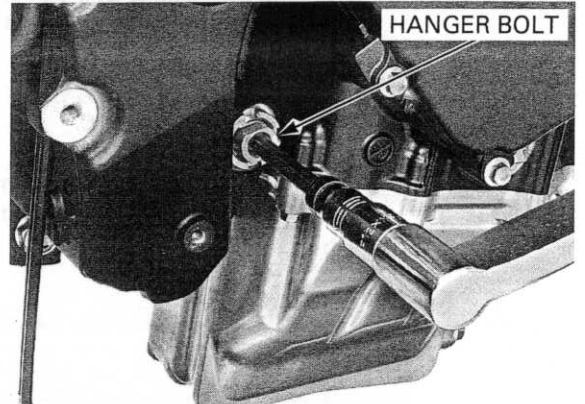

Hold the adjusting bolt by holding the hanger bolt and tighten the lock nut to the specified torque.

TOOL:

Lock nut wrench

07VMA-MBB0100

TORQUE:

Actual: 54 N·m (5.5 kgf·m, 40 lbf·ft)

Indicated: 49 N·m (5.0 kgf·m, 36 lbf·ft)

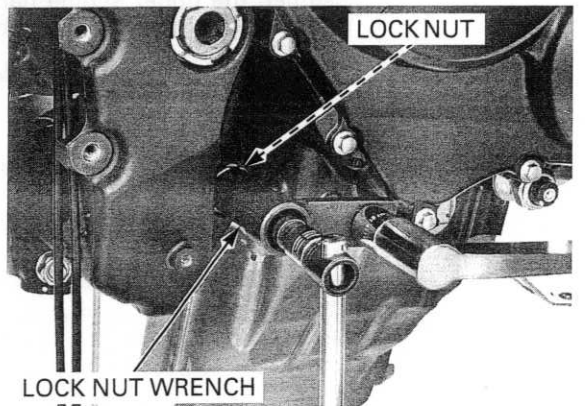

ENGINE REMOVAL/INSTALLATION

Tighten the lower engine hanger nut to the specified torque while holding the hanger bolt.

TORQUE: 59 N·m (6.0 kgf·m, 44 lbf·ft)

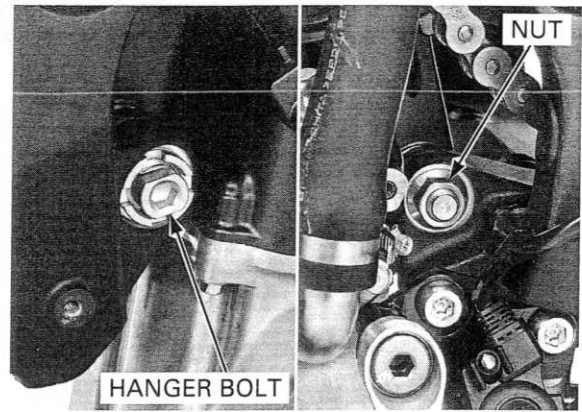

Tighten the upper engine hanger adjusting bolt to the specified torque by turning the upper engine hanger bolt.

TORQUE: 10 N·m (1.0 kgf·m, 7 lbf·ft)

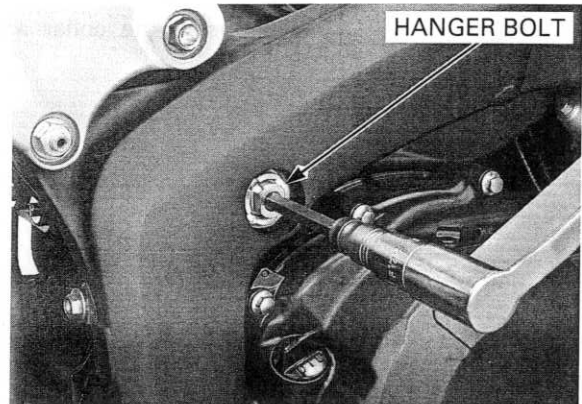

Hold the adjusting bolt by holding the hanger bolt and tighten the lock nut to the specified torque.

TOOL:

Lock nut wrench **07VMA-MBB0100**

TORQUE:

Actual: **54 N·m (5.5 kgf·m, 40 lbf·ft)**

Indicated: **49 N·m (5.0 kgf·m, 36 lbf·ft)**

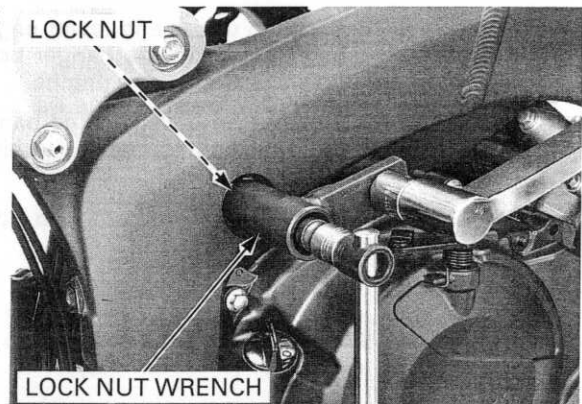

Tighten the upper engine hanger nut to the specified torque while holding the hanger bolt.

TORQUE: 59 N·m (6.0 kgf·m, 44 lbf·ft)

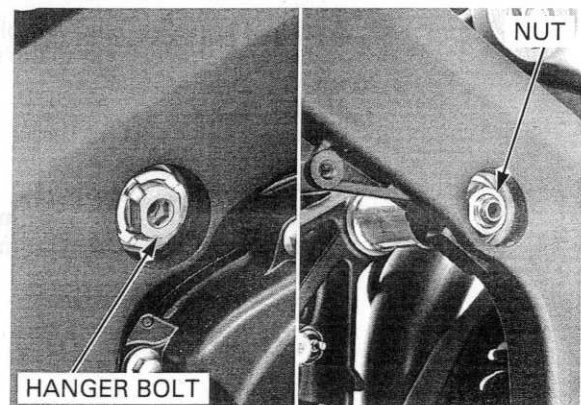

Tighten the left front engine hanger bolt to the specified torque.

TORQUE: 54 N·m (5.5 kgf·m, 40 lbf·ft)

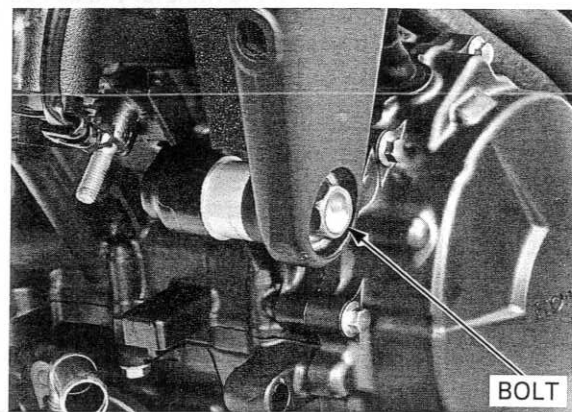

Tighten the right front engine hanger bolt to the specified torque.

TORQUE: 54 N·m (5.5 kgf·m, 40 lbf·ft)

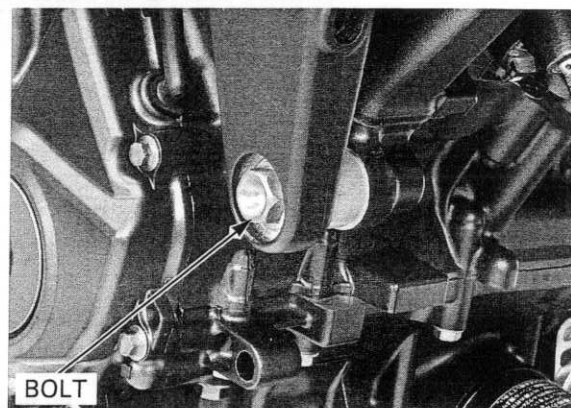

Connect the clutch cable to the clutch lifter lever.

Install the clutch cable guide plate by aligning its hole with the right crankcase cover boss and tighten the bolt securely.

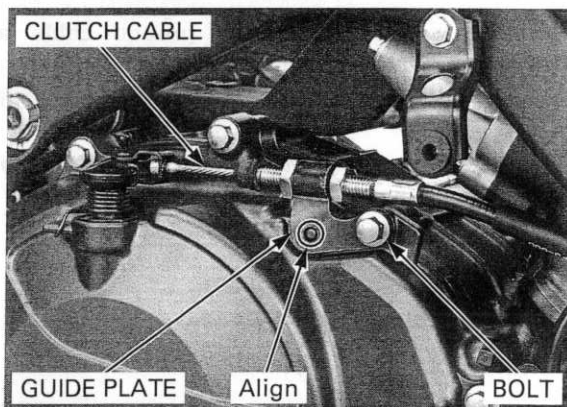

Route the wire properly (page 1-21).

Install the EOP switch wire to the wire clamp securely.

Connect the wire to the EOP switch and tighten the terminal bolt to the specified torque.

TORQUE: 2.0 N·m (0.2 kgf·m, 1.5 lbf·ft)

Install the dust cover securely.

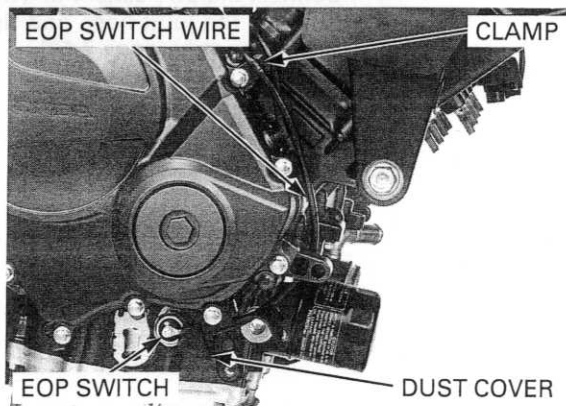

ENGINE REMOVAL/INSTALLATION

Install the radiator bracket as shown and tighten the bolt securely.

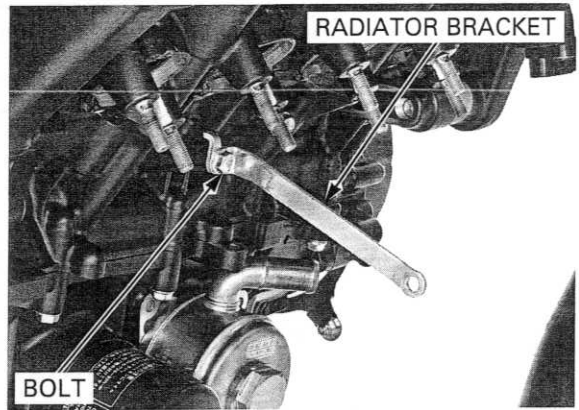

Connect the water hoses and tighten the hose clamp screws securely (page 7-19).

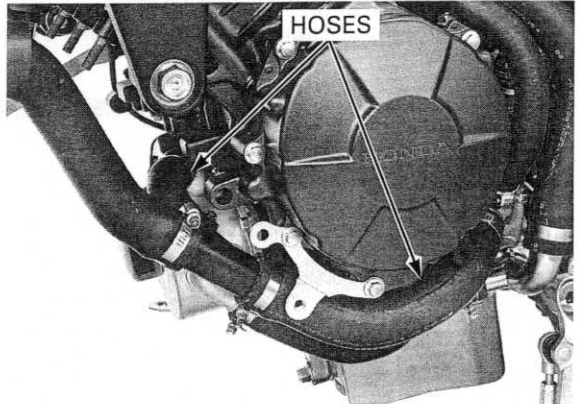

Connect the VS sensor 3P (Black) connector.

Route the wires properly (page 1-21).

Install the ground cable and tighten the bolt securely.

Connect the stater motor cable and tighten the nut to the specified torque.

TORQUE: 10 N·m (1.0 kgf·m, 7 lbf·ft)

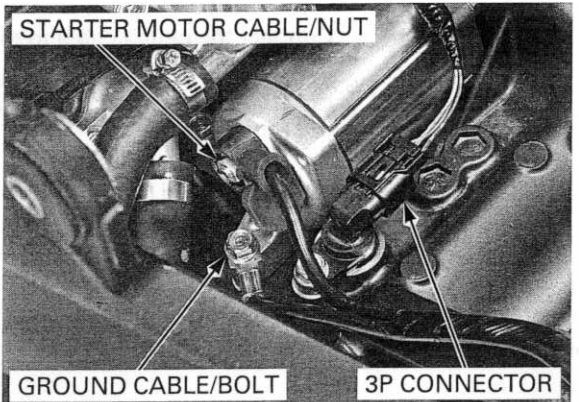

Connect the ECT sensor 3P (Gray) connector. Connect the joint hose and tighten the hose clamp screw securely (page 7-19).

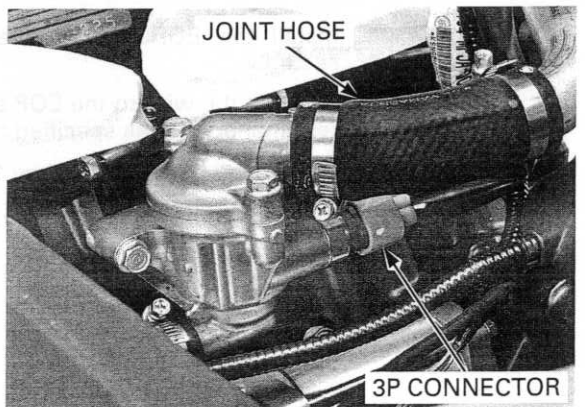

ENGINE REMOVAL/INSTALLATION

Connect the CKP sensor 2P (Black) connector.

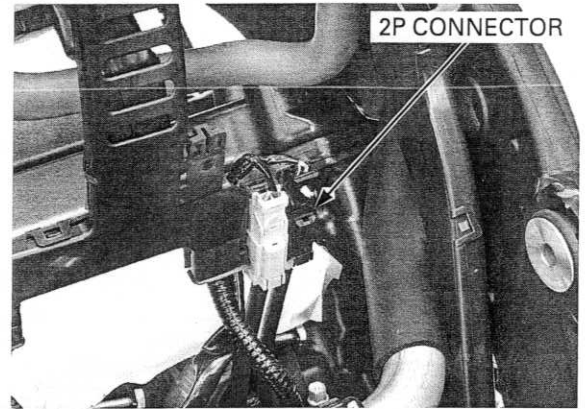

Install the drive sprocket with its marks facing out.
Install the washer and bolt, then tighten the bolt to the specified torque.

TORQUE: 54 N·m (5.5 kgf·m, 40 lbf·ft)

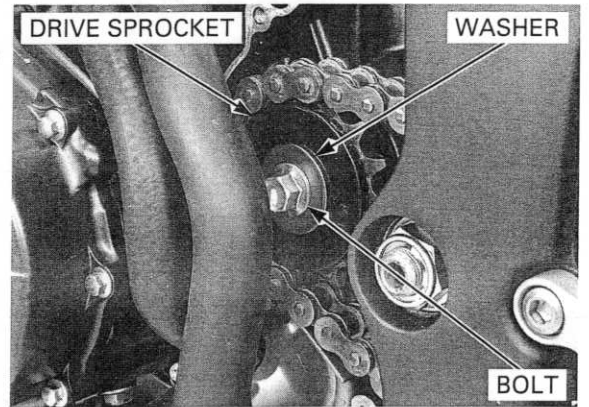

Install the guide plate, drive sprocket cover, wire clamp and tighten the bolts securely.

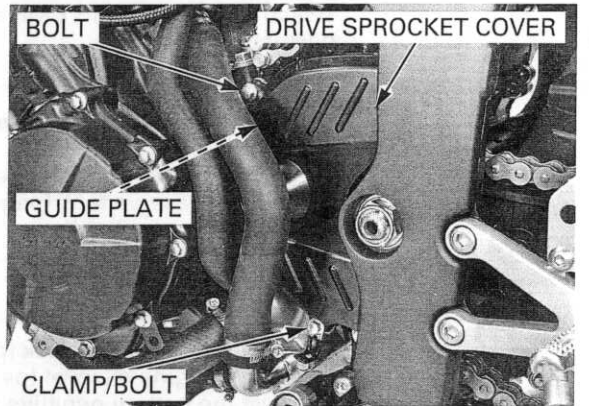

Install the gearshift arm aligning its slit with the punch mark on the gearshift spindle.

Tighten the bolt securely.

Connect the neutral switch connector.

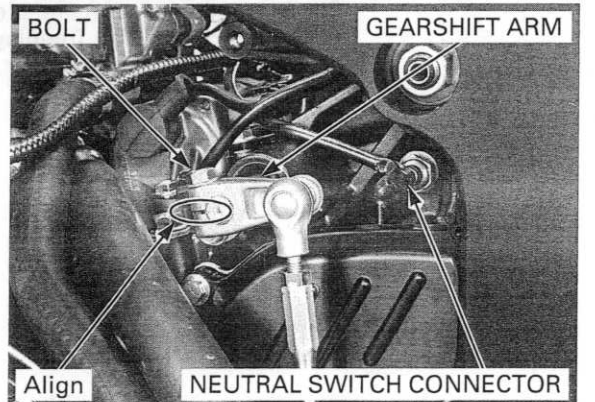

ENGINE REMOVAL/INSTALLATION

Route the wire properly (page 1-21). Install the sidestand switch wire to the wire clamps

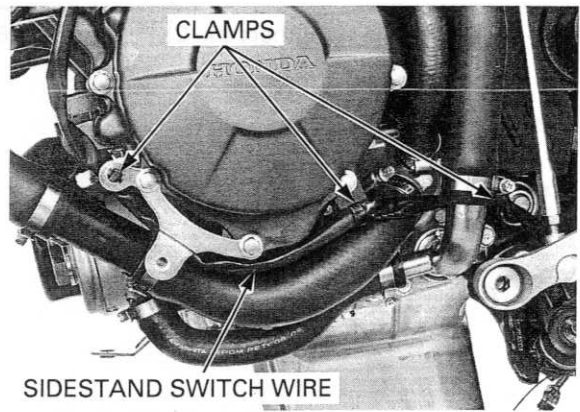

Connect the ignition sub harness 6P (Black) connector.

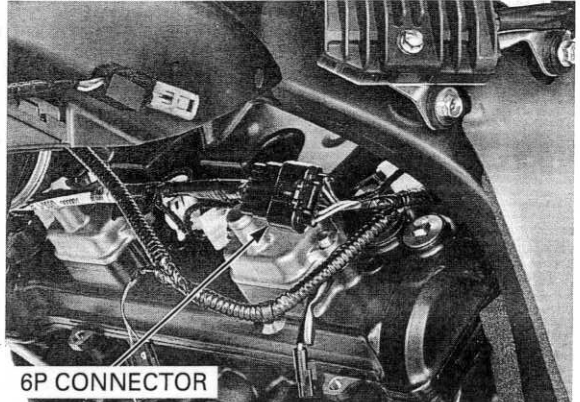

Connect the alternator 3P (Natural), sidestand switch 2P (Green) and CMP sensor 2P (Black) connectors.

Install the following:

- PAIR control solenoid valve (page 6-78)
- Throttle body (page 6-64)
- Engine guard rubber (page 6-51)
- Radiator reserve tank (page 7-20)
- Radiator (page 7-15)
- Exhaust pipe (page 3-26)
- Middle cowls (page 3-8)
- Lower cowl (page 3-6)

Adjust the drive chain slack (page 4-24).
Check the engine oil level (page 4-17).
Connect the battery negative (-) cable (page 17-6).
Fill the cooling system and bleed any air (page 7-7).
Check the clutch lever freeplay (page 4-31).
Check the exhaust system for leaks.
Check for coolant leaks.

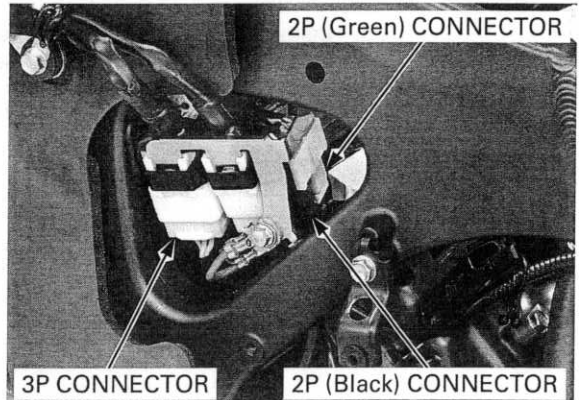

9. CYLINDER HEAD/VALVES

COMPONENT LOCATION	9-2	CYLINDER HEAD INSPECTION	9-17
SERVICE INFORMATION	9-3	VALVE GUIDE REPLACEMENT	9-20
TROUBLESHOOTING	9-6	VALVE SEAT INSPECTION/ REFACING	9-21
CYLINDER COMPRESSION TEST	9-7	CYLINDER HEAD ASSEMBLY	9-24
CYLINDER HEAD COVER REMOVAL	9-7	CYLINDER HEAD INSTALLATION	9-26
CYLINDER HEAD COVER DISASSEMBLY	9-8	CAMSHAFT INSTALLATION	9-28
CAMSHAFT REMOVAL	9-9	CYLINDER HEAD COVER ASSEMBLY	9-33
CYLINDER HEAD REMOVAL	9-14	CYLINDER HEAD COVER INSTALLATION	9-34
CYLINDER HEAD DISASSEMBLY	9-16	CAM CHAIN TENSIONER LIFTER	9-35

CYLINDER HEAD/VALVES

COMPONENT LOCATION

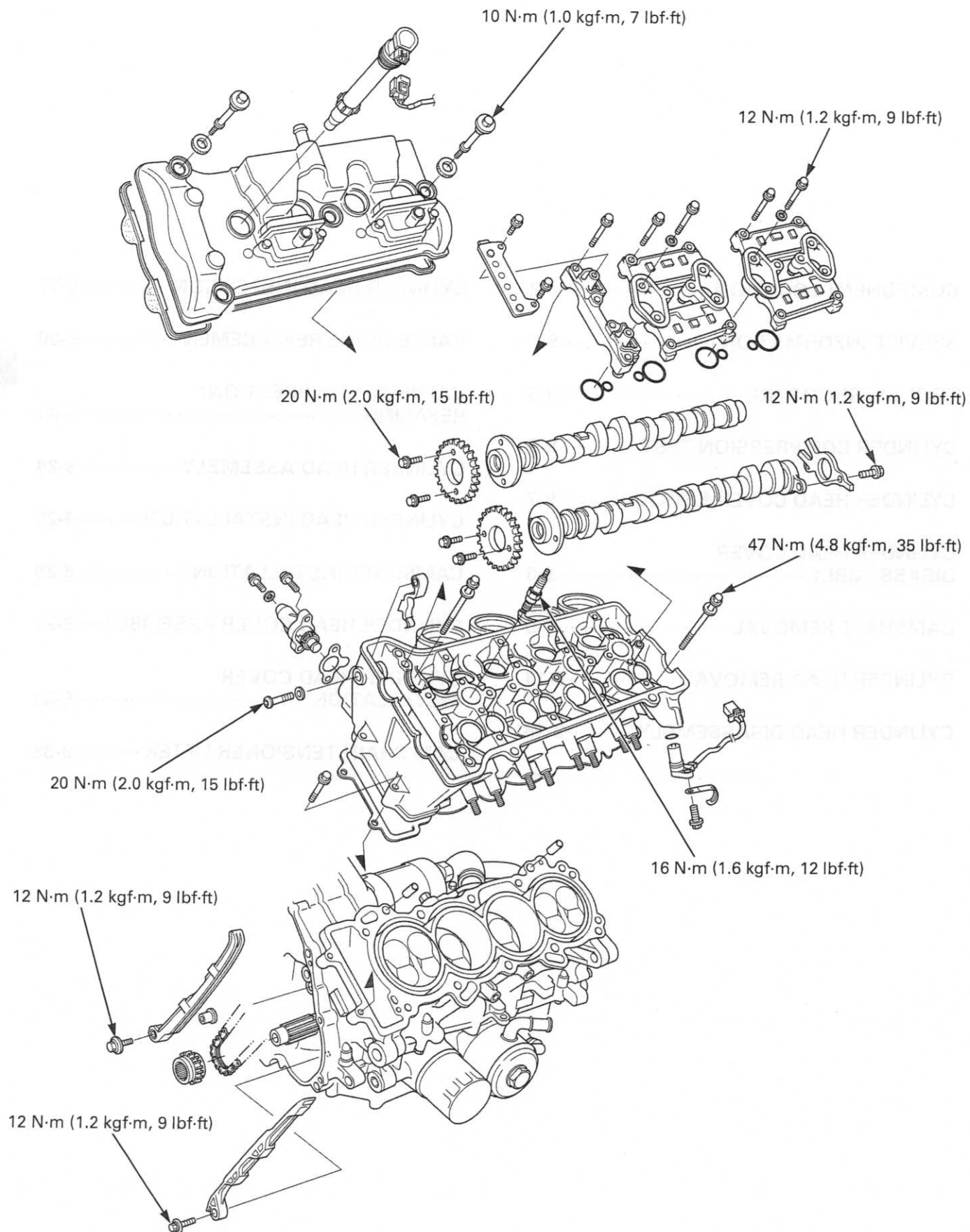

SERVICE INFORMATION

GENERAL

- This section covers service of the cylinder head, valves and camshaft.
- The cylinder head services can be done with the engine installed in the frame.
- When disassembling, mark and store the disassembled parts to ensure that they are reinstalled in their original locations.
- Clean all disassembled parts with cleaning solvent and dry them by blowing them off with compressed air before inspection.
- Camshaft lubricating oil is fed through oil passages in the cylinder head. Clean the oil passages before assembling the cylinder head.
- Be careful not to damage the mating surfaces when removing the cylinder head cover and cylinder head.

SPECIFICATIONS

Unit: mm (in)





ITEM		STANDARD	SERVICE LIMIT
Cylinder compression		1,226 kPa (12.5 kgf/cm ² , 178psi) at 350 rpm	-
Valve clearance	IN	0.20 ± 0.03 (0.008 ± 0.001)	-
	EX	0.28 ± 0.03 (0.011 ± 0.001)	-
Camshaft	Cam lobe height	IN	36.36 – 36.60 (1.431 – 1.441)
		EX	35.34 – 35.58 (1.391 – 1.401)
	Runout	-	0.05 (0.002)
	Oil clearance	0.020 – 0.062 (0.0008 – 0.0024)	0.10 (0.004)
Valve lifter	Valve lifter O.D.	IN	25.978 – 25.993 (1.0228 – 1.0233)
		EX	22.478 – 22.493 (0.8850 – 0.8855)
	Valve lifter bore I.D.	IN	26.010 – 26.026 (1.0240 – 1.0246)
		EX	22.510 – 22.526 (0.8862 – 0.8868)
Valve, valve guide	Valve stem O.D.	IN	3.975 – 3.990 (0.1565 – 0.1571)
		EX	3.965 – 3.980 (0.1561 – 0.1567)
	Valve guide I.D.	IN/EX	4.000 – 4.012 (0.1575 – 0.1580)
	Stem-to-guide clearance	IN	0.010 – 0.037 (0.0004 – 0.0015)
		EX	0.020 – 0.047 (0.0008 – 0.0019)
	Valve guide projection above cylinder head	IN	17.1 – 17.4 (0.67 – 0.69)
		EX	15.8 – 16.1 (0.62 – 0.63)
Valve seat width	IN/EX	0.90 – 1.10 (0.035 – 0.043)	
Valve spring free length	IN	Inner	36.17 (1.424)
		Outer	40.38 (1.590)
	EX	40.80 (1.606)	
Cylinder head warpage		-	0.10 (0.004)

TORQUE VALUES

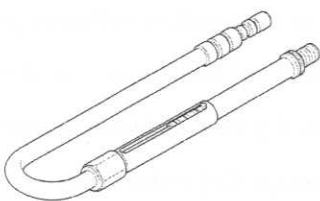
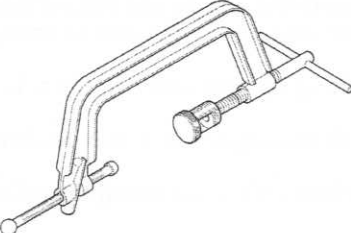
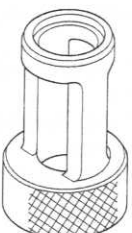
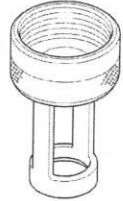

Cylinder head bolt	47 N·m (4.8 kgf·m, 35 lbf·ft)	Apply molybdenum oil solution to the threads and seating surface
Camshaft holder bolt	12 N·m (1.2 kgf·m, 9 lbf·ft)	Apply oil to the threads and seating surface
Cylinder head cover bolt	10 N·m (1.0 kgf·m, 7 lbf·ft)	
PAIR check valve cover bolt	12 N·m (1.2 kgf·m, 9 lbf·ft)	Apply locking agent to the threads
Cam sprocket bolt	20 N·m (2.0 kgf·m, 15 lbf·ft)	Apply locking agent to the threads
CMP sensor rotor bolt	12 N·m (1.2 kgf·m, 9 lbf·ft)	Apply locking agent to the threads
Cam chain tensioner A pivot bolt	12 N·m (1.2 kgf·m, 9 lbf·ft)	Apply locking agent to the threads
Cam chain tensioner B pivot bolt	20 N·m (2.0 kgf·m, 15 lbf·ft)	Apply locking agent to the threads
Cam chain guide A bolt	12 N·m (1.2 kgf·m, 9 lbf·ft)	
Spark plug	16 N·m (1.6 kgf·m, 12 lbf·ft)	
Insulator mounting bolt	12 N·m (1.2 kgf·m, 9 lbf·ft)	

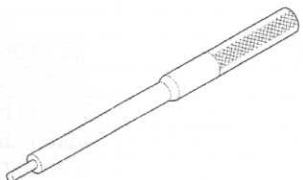
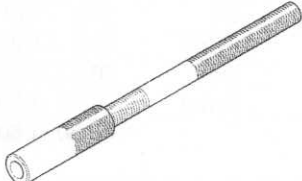
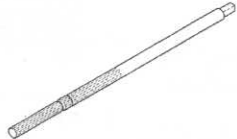
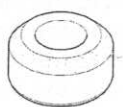
CYLINDER HEAD/VALVES

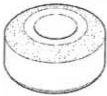
TOOLS

<p>Compression gauge attachment 07RMJ-MY50100</p>  <p>or equivalent commercially available in U.S.A.</p>	<p>Valve spring compressor 07757-0010000</p> 	<p>Valve spring compressor attachment (IN) 07959-KM30101</p> 
<p>Valve spring compressor attachment (EX) 07JME-KY20100</p> 	<p>Tappet hole protector (IN) 07HMG-MR70002</p>  <p>Not available in U.S.A.</p>	<p>Tappet hole protector (EX) 07JMG-KY20100</p>  <p>Not available in U.S.A.</p>
<p>Valve guide driver 07JMD-KY20100</p> 	<p>Valve guide driver 07743-0020000</p>  <p>Not available in U.S.A.</p>	<p>Valve guide reamer, 4.008 mm 07MMH-MV90100</p>  <p>or 07MMH-MV9010A (U.S.A. only)</p>
<p>Valve seat cutter, 29 mm (45° IN) 07780-0010300</p>  <p>or equivalent commercially available in U.S.A.</p>	<p>Valve seat cutter, 24 mm (45° EX) 07780-0010600</p>  <p>or equivalent commercially available in U.S.A.</p>	<p>Flat cutter, 29 mm (32° IN) 07780-0013400</p>  <p>or equivalent commercially available in U.S.A.</p>

CYLINDER HEAD/VALVES

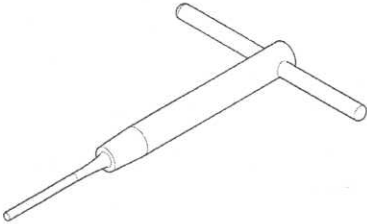
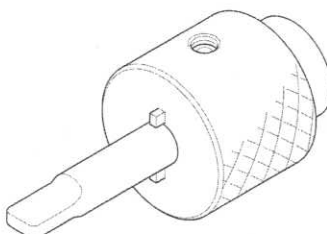
<p>Flat cutter, 24 mm (32° EX) 07780-0012500</p>  <p>or equivalent commercially available in U.S.A.</p>	<p>Interior cutter, 30 mm (60° IN) 07780-0014000</p>  <p>or equivalent commercially available in U.S.A.</p>	<p>Interior cutter, 24 mm (60° EX) 070PH-Z0D0100</p>  <p>or equivalent commercially available in U.S.A.</p>
<p>Cutter holder, 4.0 mm 07781-0010500</p>  <p>or equivalent commercially available in U.S.A.</p>	<p>Tensioner stopper 070MG-0010100</p> 	

CYLINDER HEAD/VALVES

TROUBLESHOOTING

- Engine top-end problems usually affect engine performance. These problems can be diagnosed by a compression test or by tracing engine noises to the top-end with a sounding rod stethoscope.
- If the performance is poor at low speeds, check for white smoke in the crankcase breather hose. If the hose is smoky, check for a seized piston ring (page 13-15).

Compression too low, hard starting or poor performance at low speed

- Valves:
 - Incorrect valve clearance adjustment
 - Burned or bent valve
 - Incorrect valve timing
 - Broken valve spring
 - Uneven valve seating
- Cylinder head:
 - Leaking or damaged cylinder head gasket
 - Warped or cracked cylinder head
 - Loose spark plug
- Worn cylinder, piston or piston rings (page 13-15)

Compression too high, overheating or knocking

- Excessive carbon build-up on piston crown or on combustion chamber

Excessive smoke

- Cylinder head:
 - Worn valve stem or valve guide
 - Damaged stem seal
- Worn cylinder, piston or piston rings (page 13-15)

Excessive noise

- Cylinder head:
 - Incorrect valve clearance adjustment
 - Sticking valve or broken valve spring
 - Damaged or worn camshaft
 - Loose or worn cam chain
 - Worn or damaged cam chain
 - Worn or damaged cam chain tensioner
 - Worn cam sprocket teeth
- Worn cylinder, piston or piston rings (page 13-15)

Rough idle

- Low cylinder compression

CYLINDER COMPRESSION TEST

Warm the engine to normal operating temperature. Stop the engine and remove the all direct ignition coil/spark plug caps and spark plugs (page 4-9).

Lift and support the fuel tank (page 4-5).

Disconnect the fuel pump unit 2P (Black) connector.

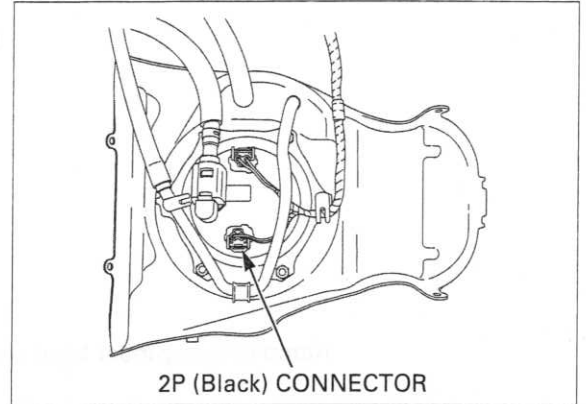

2P (Black) CONNECTOR

Install a compression gauge into the spark plug hole.

TOOL:

Compression gauge attachment

07RMJ-MY50100 or equivalent commercially available in U.S.A.

Open the throttle all the way and crank the engine with the starter motor until the gauge reading stops rising.

The maximum reading is usually reached within 4 – 7 seconds.

Standard:

1,226 kPa (12.5 kgf/cm², 178 psi) at 350 rpm

Low compression can be caused by:

- Blown cylinder head gasket
- Improper valve clearance adjustment
- Valve leakage
- Worn piston ring or cylinder

High compression can be caused by:

- Carbon deposits in combustion chamber or on piston head

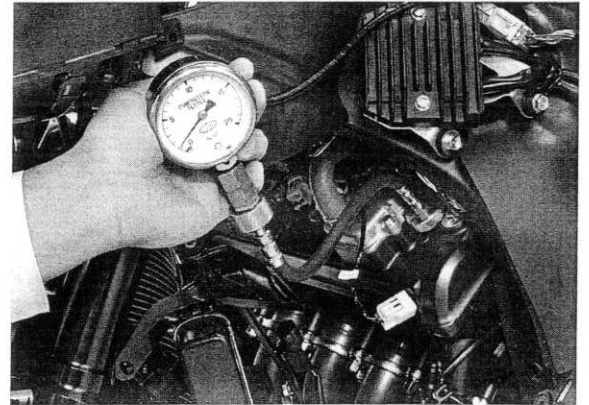

CYLINDER HEAD COVER REMOVAL

Remove the following:

- Air cleaner housing (page 6-52)
- PAIR control solenoid valve (page 6-78)
- Direct ignition coils (page 4-9)

Disconnect the breather hose from the cylinder head cover.

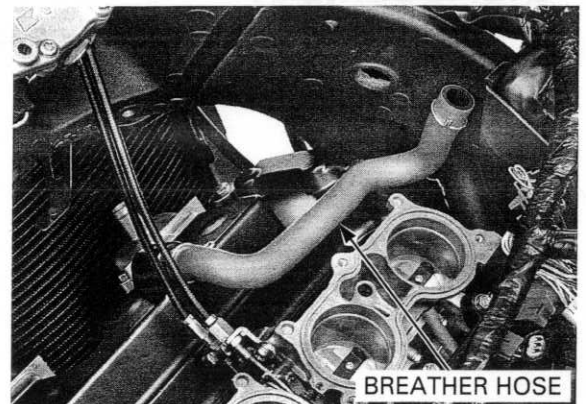

CYLINDER HEAD/VALVES

Remove the trim clip and right heat guard plate.

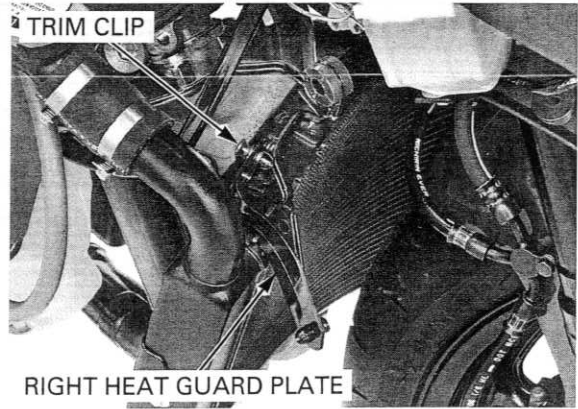

Remove the cylinder head cover bolts and washers.

BOLTS/WASHERS

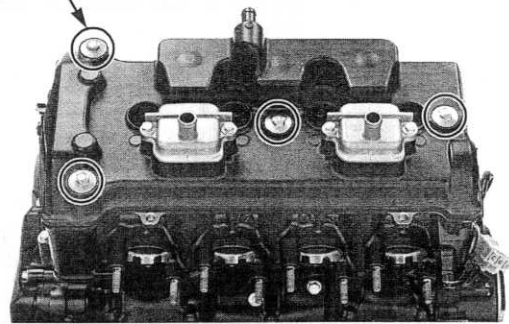

Be careful not to damage the radiator fins.

Remove the cylinder head cover from the cylinder head.

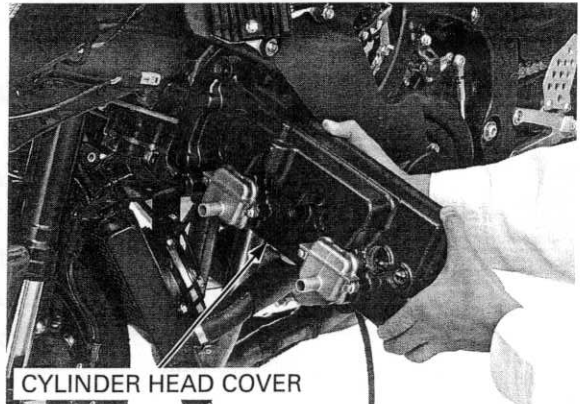

CYLINDER HEAD COVER DISASSEMBLY

Remove the cylinder head cover packing.

PACKING

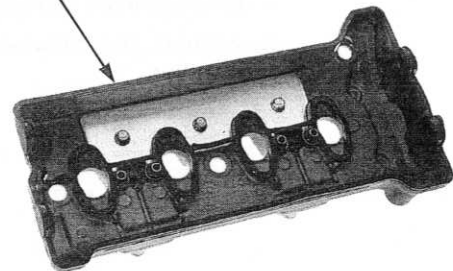

Remove the bolts and PAIR check valve cover.

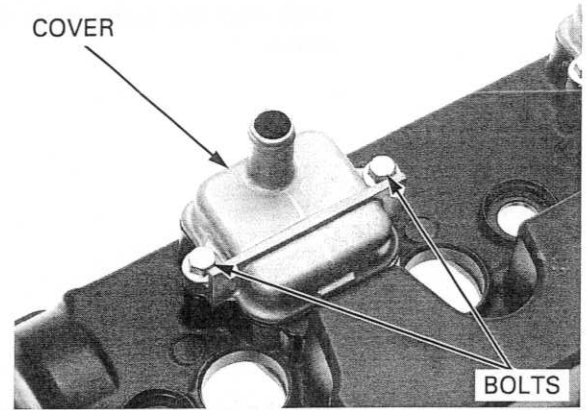

Remove the PAIR check valves from the cylinder head cover.

Check the PAIR check valve for wear or damage, replace if necessary.

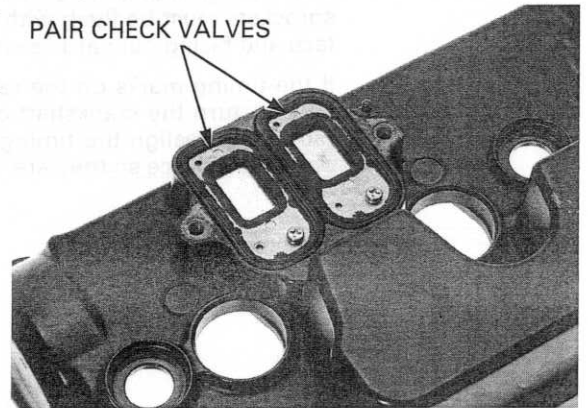

Remove the baffle plates from the cylinder head cover.

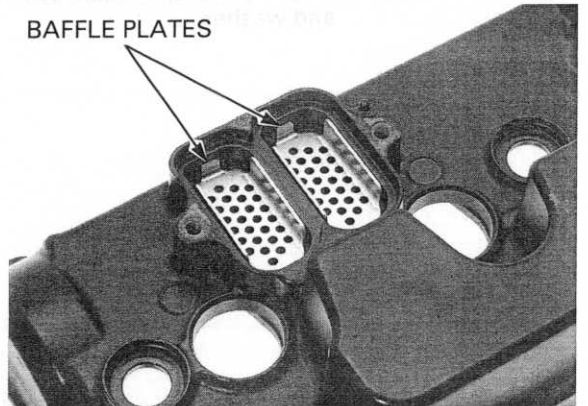

CAMSHAFT REMOVAL

Remove the following:

- CMP sensor (page 6-71)
- Cylinder head cover (page 9-7)

Remove the timing hole cap and O-ring.

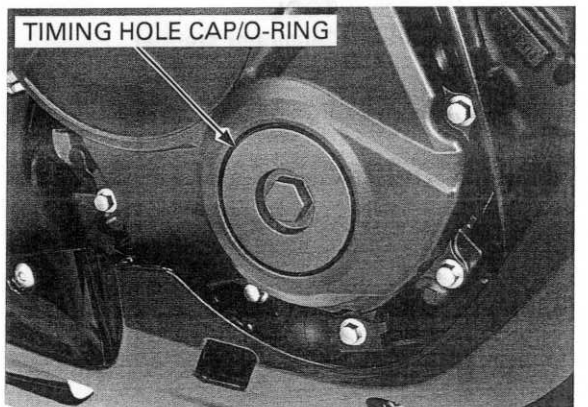

CYLINDER HEAD/VALVES

Turn the crankshaft clockwise and align the "T" mark with the index mark on the right crankcase cover.

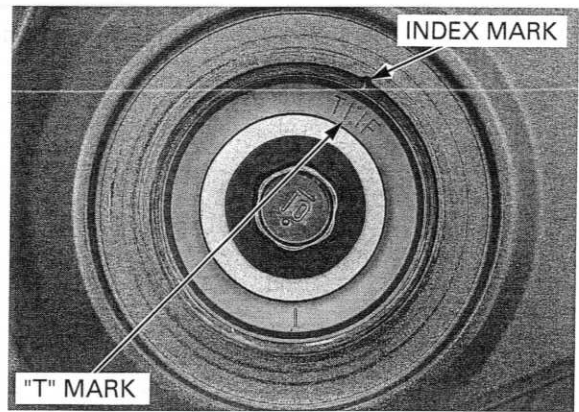

The timing marks ("IN" and "EX") on the cam sprockets must be flush with the cylinder head surface and facing outward as shown.

If the timing marks on the cam sprocket are facing inward, turn the crankshaft clockwise one full turn (360°) and realign the timing marks with the cylinder head surface so they are facing outward.

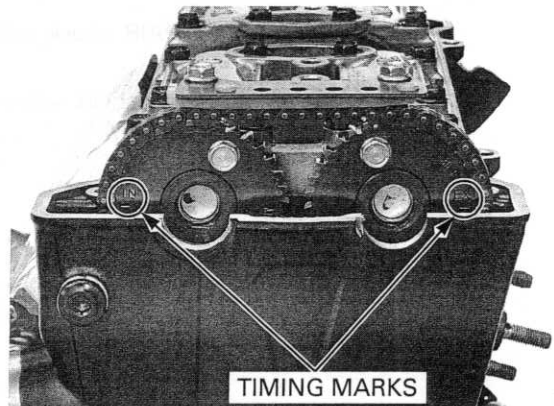

Remove the cam chain tensioner lifter sealing bolt and washer.

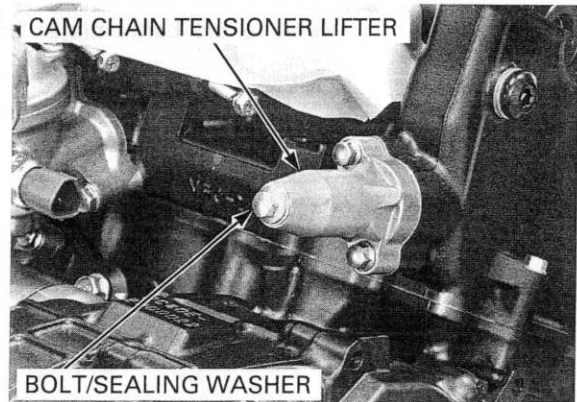

Use a 1.5 mm hex wrench to remove the screw.

Remove the screw and end piece from the tensioner stopper.

TOOL:
Tensioner stopper

070MG-0010100

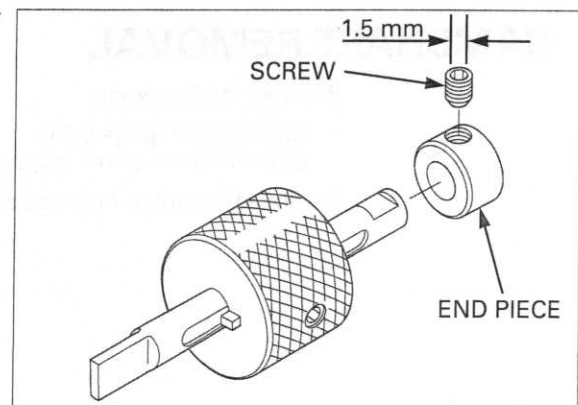

Turn the tensioner lifter shaft fully in (clockwise) and secure it using the tensioner stopper to prevent damaging the cam chain.

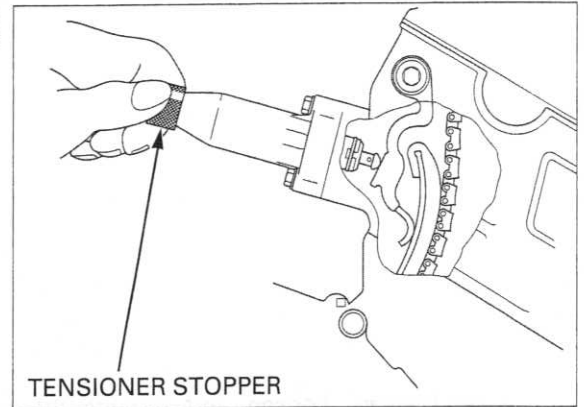

It is not necessary to remove the cam sprocket from the camshaft except when replacing the camshaft and/or cam sprocket. If you plan to replace the camshaft and/or cam sprocket, loosen the cam sprocket bolts as follows:

- Remove the cam sprocket bolts from the intake and exhaust camshafts.

NOTE:

- Be careful not to drop the cam sprocket bolts and cam sprocket into the crankcase.

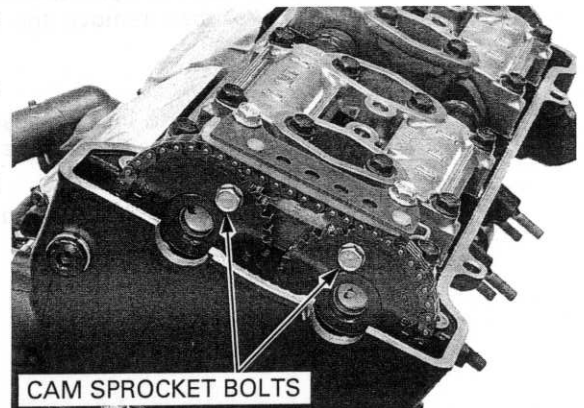

- Turn the crankshaft clockwise one full turn (360°), remove the other cam sprocket bolts from the camshafts.
- Remove the bolts and cam chain guide B.
- Remove the cam sprockets from the camshafts.

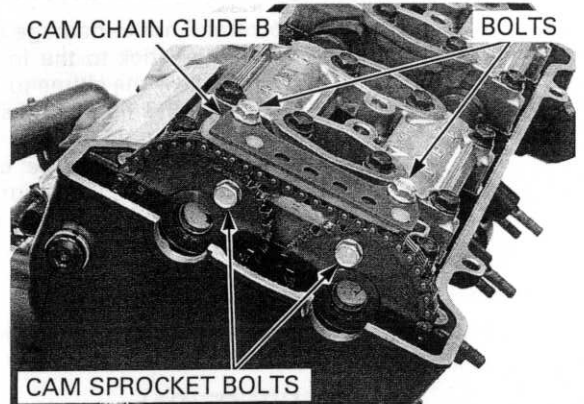

- Remove the bolts and CMP sensor rotor from the exhaust camshaft.

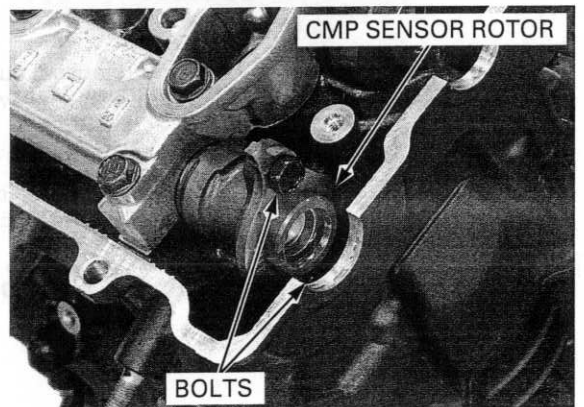

CYLINDER HEAD/VALVES

Remove the bolts and cam chain guide B.

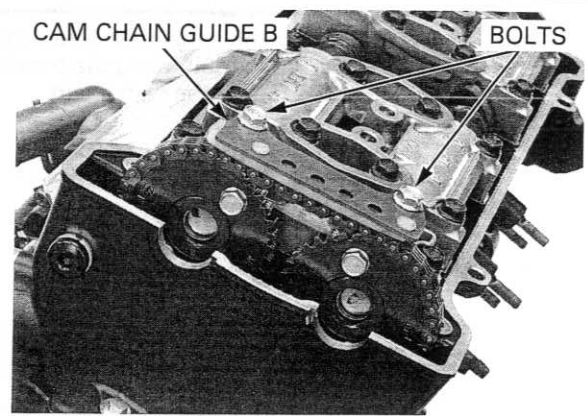

Suspend the cam chain with a piece of wire to prevent the chain from falling into the crankcase.

Loosen and remove the camshaft holder bolts/washers, then remove the camshaft holders and camshafts.

NOTE:

From outside to inside, loosen the bolts in a criss-cross pattern in several steps or the camshaft holder might break.

Do not forcibly remove the dowel pins from the camshaft holders.

BOLTS/WASHERS

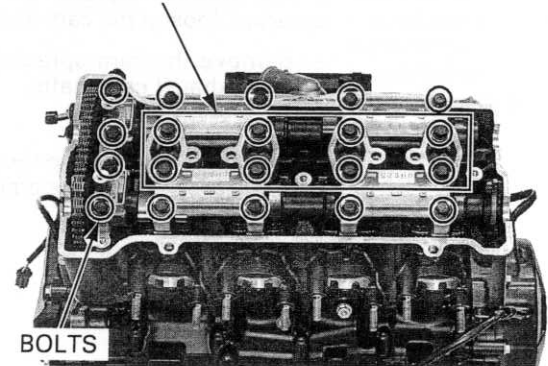

Remove the valve lifters and shims.

- Be careful not to damage the valve lifter bore.
- Shim may stick to the inside of the valve lifter. Do not allow the shims to fall into the crankcase.
- Mark all valve lifters and shims to ensure correct reassembly in their original locations.
- The valve lifter can be easily removed with a valve lapping tool or magnet.
- The shims can be easily removed with a tweezers or magnet.

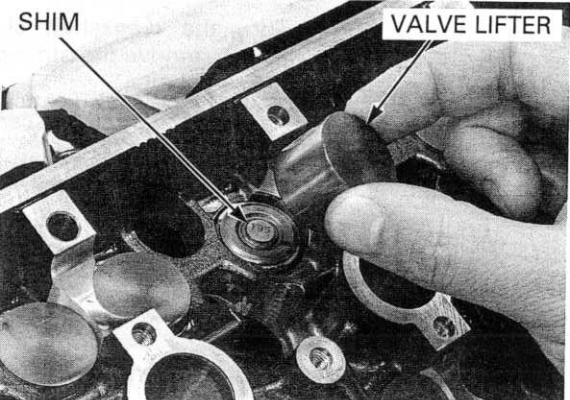

INSPECTION

CAMSHAFT

Check the cam and journal surfaces of the camshaft for scoring, scratches or evidence of insufficient lubrication.

Check the oil holes in the camshaft for clogging.

Support both sides of the camshaft (at journals) with V-blocks and check the camshaft runout with a dial gauge.

SERVICE LIMIT: 0.05 mm (0.002 in)

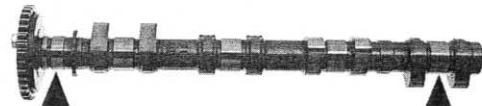

Using a micrometer, measure each cam lobe height.

SERVICE LIMITS:

IN: 36.34 mm (1.431 in)

EX: 35.32 mm (1.391 in)

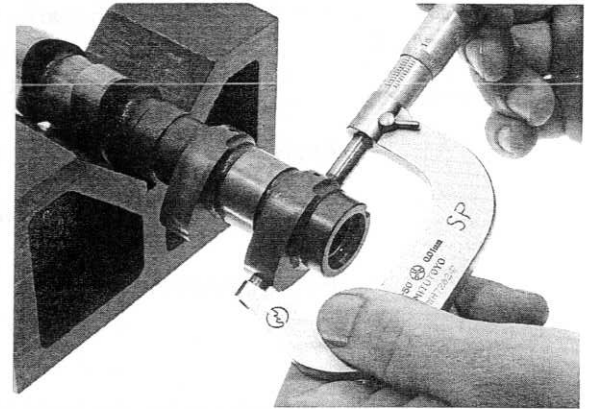

CAMSHAFT HOLDERS

Inspect the bearing surface of each camshaft holder for scoring, scratches, or evidence of insufficient lubrication.

Inspect the oil orifices of the holders for clogging.

CAMSHAFT HOLDER A

CAMSHAFT HOLDER B

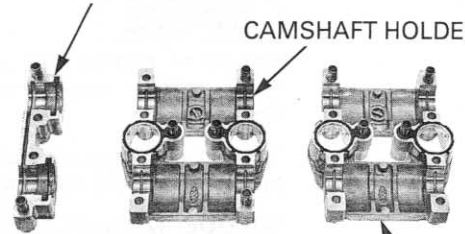

CAMSHAFT HOLDER C

CAM CHAIN GUIDE B

Inspect the cam chain slipper surface of the cam chain guide B for wear or damage.

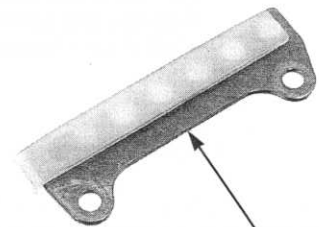

CAM CHAIN GUIDE B

CAMSHAFT OIL CLEARANCE

Do not rotate the camshaft when using plastigauge.

Wipe any oil from the journals of the camshaft, cylinder head and camshaft holders.

Lay a strip of plastigauge lengthwise on top of each camshaft journal.

PLASTIGAUGE

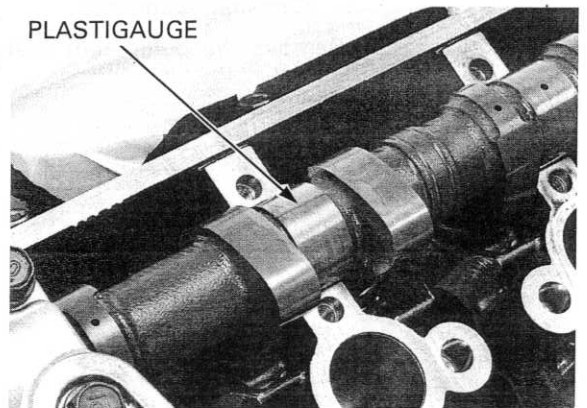

CYLINDER HEAD/VALVES

Be sure the dowel pins in the camshaft holder align the holes in the cylinder head.

Install each camshaft holder to the correct locations with the identification marks.

- No mark: right camshaft holder
- "R" mark: center camshaft holder
- "L" mark: left camshaft holder

Apply oil to the threads and seating surfaces of the camshaft holder bolts.

Install the holder bolts with the eight sealing washers.

Finger tighten the bolts.

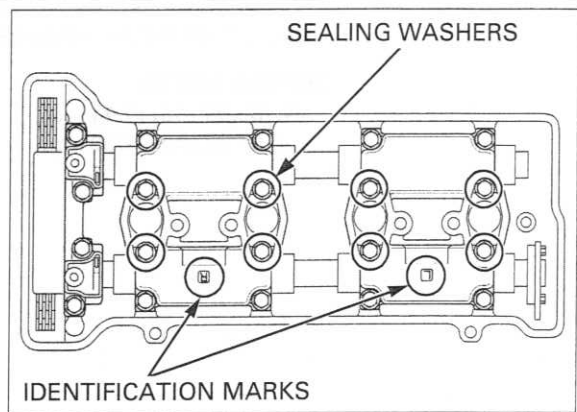

Gradually tighten the camshaft holder bolts until the camshaft holders lightly contact the cylinder head surface.

NOTICE

Failure to tighten the camshaft holder in a criss-cross pattern might cause a camshaft holder to break.

Tighten all camshaft holder bolts in the numerical order cast on the camshaft holders.

TORQUE: 12 N·m (1.2 kgf·m, 9 lbf·ft)

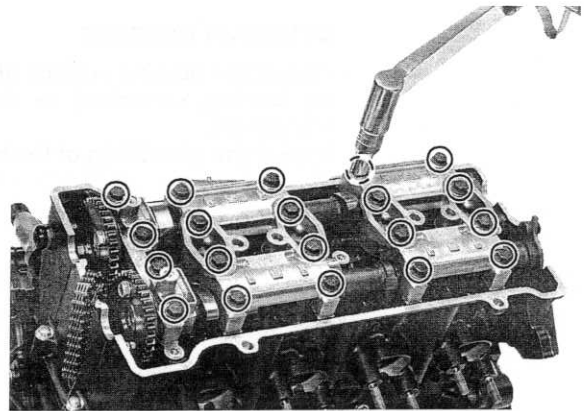

Remove the camshaft holders and measure the width of each plastigauge. The widest thickness determines the oil clearance.

SERVICE LIMIT: 0.10 mm (0.004 in)

When the service limits are exceeded, replace the camshaft and recheck the oil clearance. Replace the cylinder head and camshaft holders as a set if the clearance still exceeds the service limit.

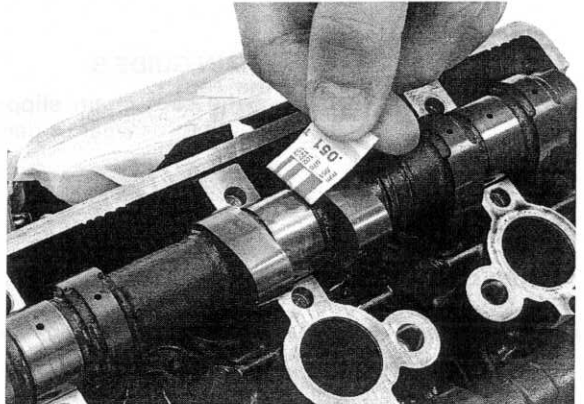

CYLINDER HEAD REMOVAL

Remove the following:

- Thermostat housing (page 7-8)
- Camshaft (page 9-9)

Remove the bolts, cam chain tensioner lifter and gasket.

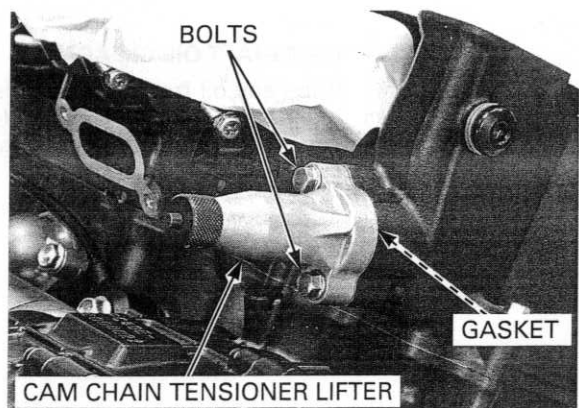

Remove the two 6 mm bolts.

Loosen the 9 mm bolts in a crisscross pattern in two or three steps.

Remove the ten 9 mm bolts/washers.

Remove the cylinder head.

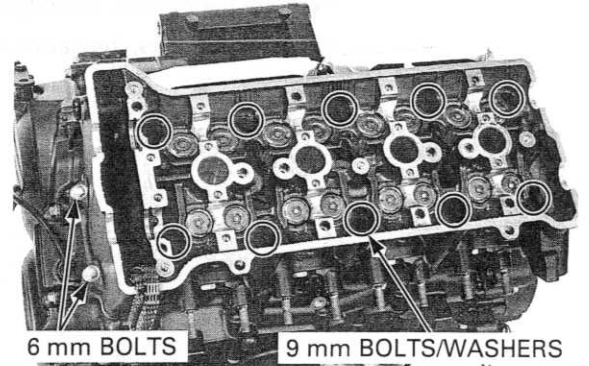

Remove the gasket and dowel pins.

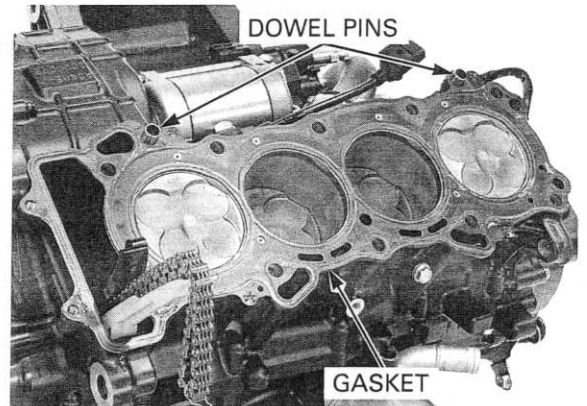

Remove the following:

- Right crankcase cover (page 10-5)
- Starter clutch (page 10-17)

Remove the bolt, cam chain tensioner A and collar.
Remove the bolt, washer and cam chain guide A.

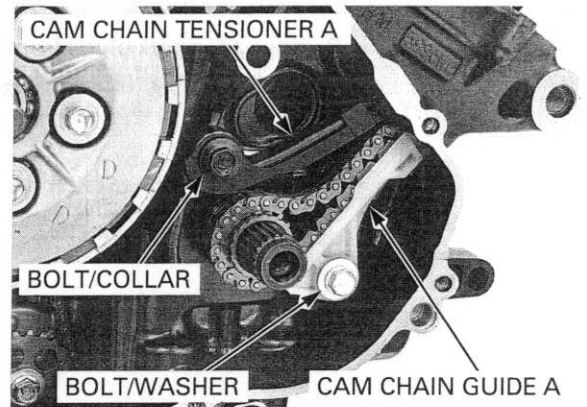

Remove the cam chain and timing sprocket from the crankshaft.

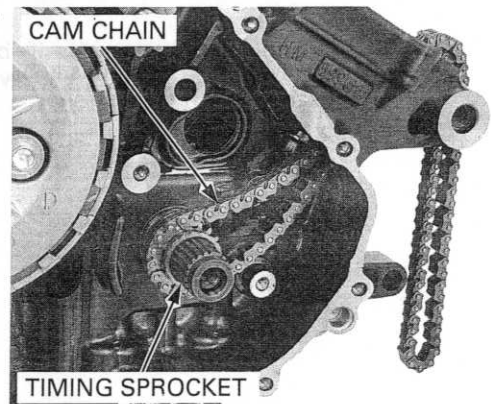

CYLINDER HEAD/VALVES

CYLINDER HEAD DISASSEMBLY

Remove the cylinder head (page 9-14).
Remove the bolts, insulators and O-rings.

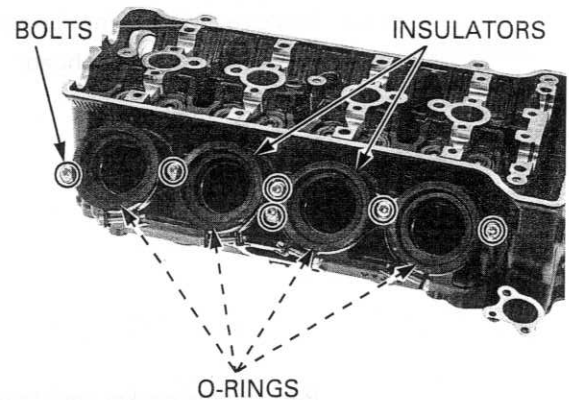

Remove the bolt, sealing washer and cam chain tensioner B from the cylinder head.



Remove the spark plugs from the cylinder head.
Install the tappet hole protector into the valve lifter bore.

TOOLS:

Tappet hole protector (IN)
Tappet hole protector (EX)

07HMG-MR70002
07JMG-KY20100
Not available in
U.S.A.

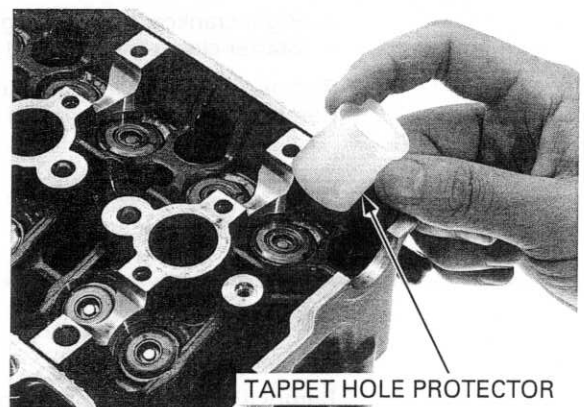

An equivalent tool can easily be made from a plastic 35 mm film container as shown.

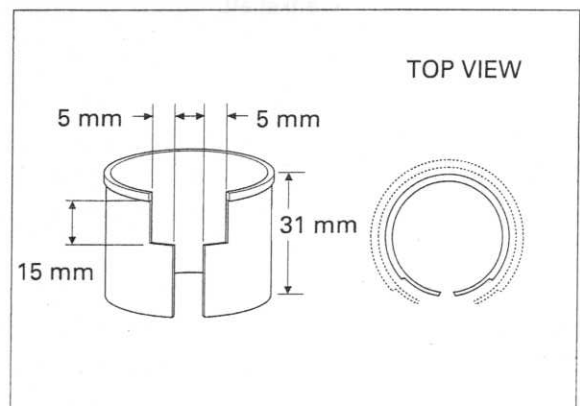

To prevent loss of tension, do not compress the valve springs more than necessary to remove the cotters.

Remove the valve spring cotters using the special tools as shown.

TOOLS:

- Valve spring compressor**
- Valve spring compressor attachment (IN)**
- Valve spring compressor attachment (EX)**

07757-0010000

07959-KM30101

07JME-KY20100

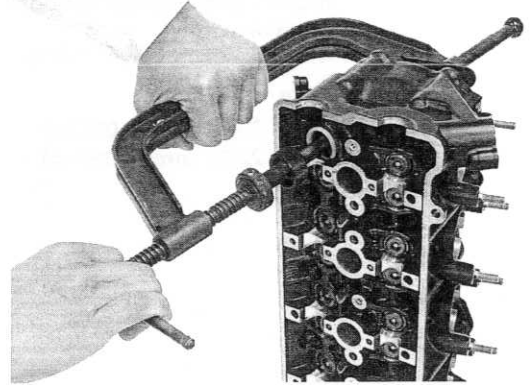

Mark all parts during disassembly so they can be placed back in their original locations.

Remove the following:

- Spring retainer
- Inner/outer valve springs (IN)
- Valve spring (EX)
- Valve
- Stem seal
- Valve spring seat

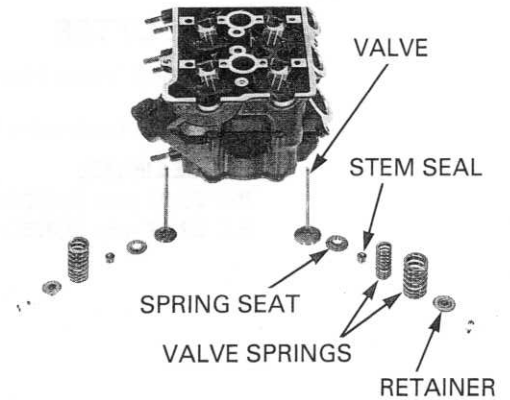

CYLINDER HEAD INSPECTION

CYLINDER HEAD

Avoid damaging the gasket surface.

Remove carbon deposits from the combustion chambers. Check the spark plug hole and valve areas for cracks.



Check the cylinder head for warpage with a straight edge and feeler gauge.

SERVICE LIMIT: 0.10 mm (0.004 in)

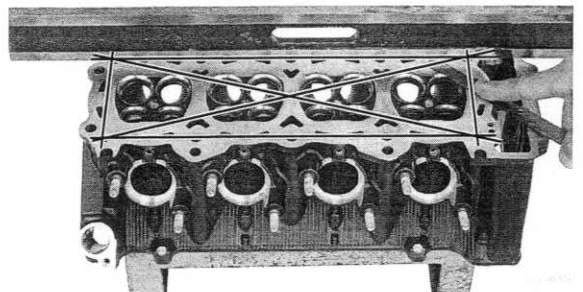

CYLINDER HEAD/VALVES

VALVE LIFTER BORE

Inspect each valve lifter bore for scratches or abnormal wear.

Measure each valve lifter bore I.D.

SERVICE LIMITS:

IN: 26.04 mm (1.025 in)

EX: 22.54 mm (0.887 in)

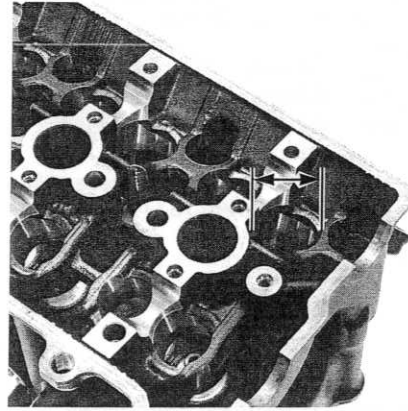

VALVE LIFTER

Inspect each valve lifter for scratches or abnormal wear.

Measure the each valve lifter O.D.

SERVICE LIMITS:

IN: 25.97 mm (1.022 in)

EX: 22.47 mm (0.885 in)



VALVE SPRING

Measure the free length of the inner and outer valve springs.

IN:

SERVICE LIMITS:

IN: Inner: 35.1 mm (1.38 in)

Outer: 39.2 mm (1.54 in)

EX: 39.6 mm (1.56 in)

Replace the springs if they are shorter than the service limits.

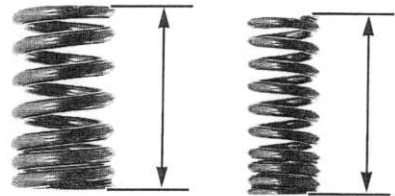

EX:

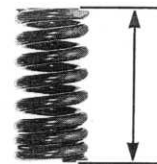

CAM CHAIN TENSIONER/CAM CHAIN GUIDE

Inspect the cam chain tensioner A and cam chain guide A for excessive wear or damage, replace them if necessary.

CAM CHAIN TENSIONER A

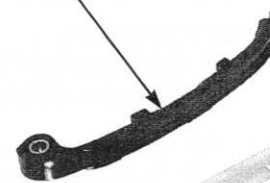

CAM CHAIN GUIDE A

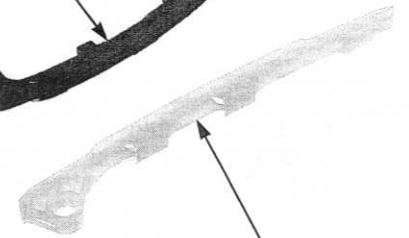

Inspect the cam chain tensioner B for excessive wear or damage, replace it if necessary.

CAM CHAIN TENSIONER B

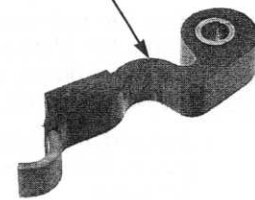

VALVE/VALVE GUIDE

Check that the valve moves smoothly in the guide. Inspect each valve for bending, burning or abnormal stem wear. Measure and record each valve stem O.D.

SERVICE LIMITS:

IN: 3.965 mm (0.1561 in)

EX: 3.955 mm (0.1557 in)



Ream the guides to remove any carbon deposits before checking clearances. Insert the reamer from the combustion chamber side of the cylinder head and always rotate the reamer clockwise.

TOOL:

Valve guide reamer, 4.008 mm 07MMH-MV90100 or 07MMH-MV9010A (U.S.A. only)

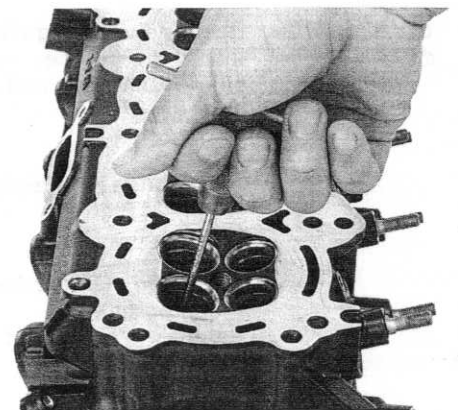

CYLINDER HEAD/VALVES

Measure and record each valve guide I.D.

SERVICE LIMIT: IN/EX: 4.04 mm (0.159 in)

Subtract each valve stem O.D. from the corresponding guide I.D. to obtain the stem-to-guide clearance.

SERVICE LIMITS:

IN: 0.075 mm (0.0030 in)

EX: 0.085 mm (0.0033 in)

Reface the valve seats whenever the valve guides are replaced (page 9-22).

If the stem-to-guide clearance is out of standard, determine if a new guide with standard dimensions would bring the clearance within tolerance. If so, replace any guides as necessary and ream to fit. If the stem-to-guide clearance exceeds the service limit with the new guides, replace the valves and guides.

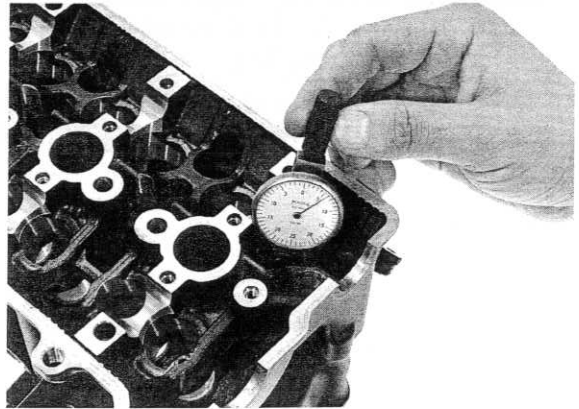

VALVE GUIDE REPLACEMENT

Chill the replacement valve guides in the freezer section of a refrigerator for about an hour.

Do not use a torch to heat the cylinder head; it may cause warping.

Heat the cylinder head to 100 – 150°C (212 – 302°F) with a hot plate or oven.

To avoid burns, wear heavy gloves when handling the heated cylinder head.

Support the cylinder head and drive out the valve guides from combustion chamber side of the cylinder head.

TOOL:

Valve guide driver

07JMD-KY20100

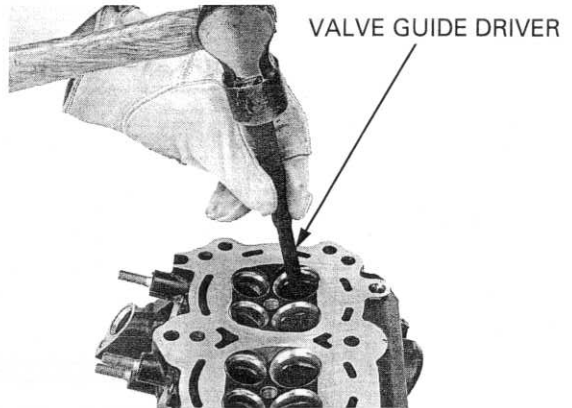

Drive in the valve guides to the specified depth from the top of the cylinder head.

SPECIFIED DEPTH:

IN: 17.1 – 17.4 mm (0.67 – 0.69 in)

EX: 15.8 – 16.1 mm (0.62 – 0.63 in)

TOOL:

Valve guide driver

07743-0020000

Not available in U.S.A.

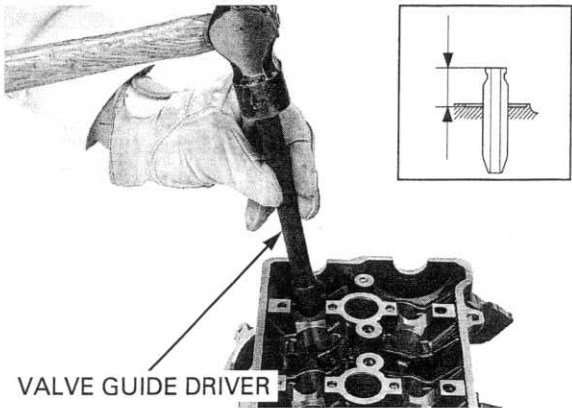

Let the cylinder head cool to room temperature.

Use cutting oil on the reamer during this operation.

Ream new valve guides after installation. Insert the reamer from the combustion chamber side of the head and also always rotate the reamer clockwise.

TOOL:

Valve guide reamer, 4.008 mm 07MMH-MV90100 or 07MMH-MV9010A (U.S.A. only)

Clean the cylinder head thoroughly to remove any metal particles.

Reface the valve seat (page 9-22).

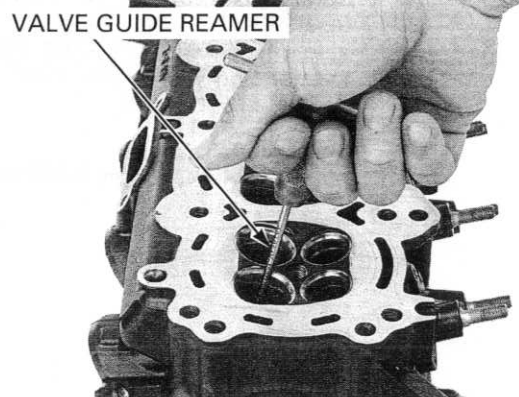

VALVE SEAT INSPECTION/REFACING

Clean the intake and exhaust valves thoroughly to remove carbon deposits.
 Apply a light coating of Prussian Blue to the valve seats.
 Tap the valves and seats using a rubber hose or other hand-lapping tool.

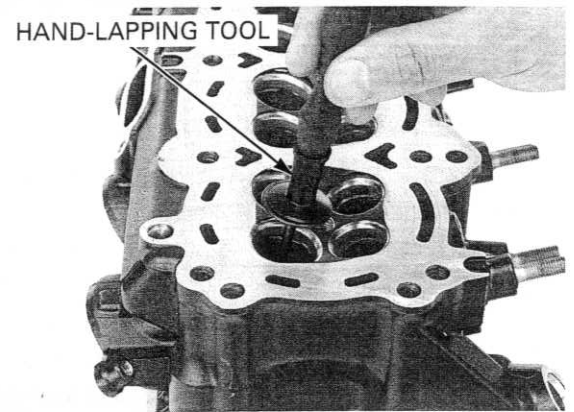

Remove the valve and inspect the valve seat face. The valve seat contact should be within the specified width and even all around the circumference.

Standard:

IN/EX: 0.90 – 1.10 mm (0.035 – 0.043 in)

SERVICE LIMIT:

IN/EX: 1.5 mm (0.06 in)

If the seat width is not within specification, reface the valve seat (page 9-22).

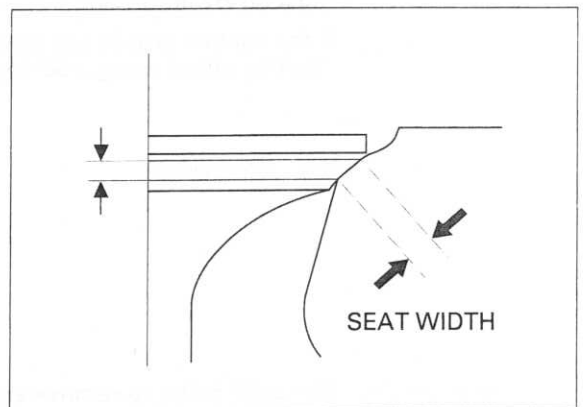

Inspect the valve seat face for:

- Uneven seat width:
 - Replace the valve and reface the valve seat.
- Damaged face:
 - Replace the valve and reface the valve seat.

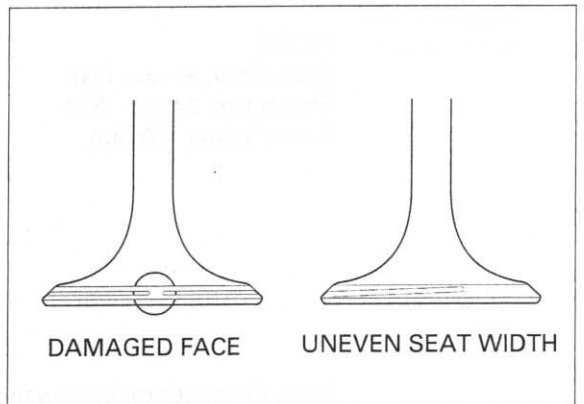

The valves cannot be ground. If a valve face is burned or badly worn or if it contacts the seat unevenly, replace the valve.

- Contact area (too high or too low)
 - Reface the valve seat.

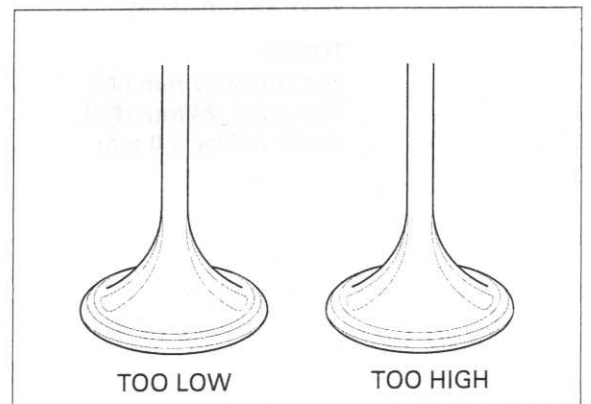

CYLINDER HEAD/VALVES

VALVE SEAT REFACING

Follow the refacing manufacturer's operating instructions. Valve seat cutters/grinders or equivalent valve seat refacing equipment are recommended to correct worn valve seats.

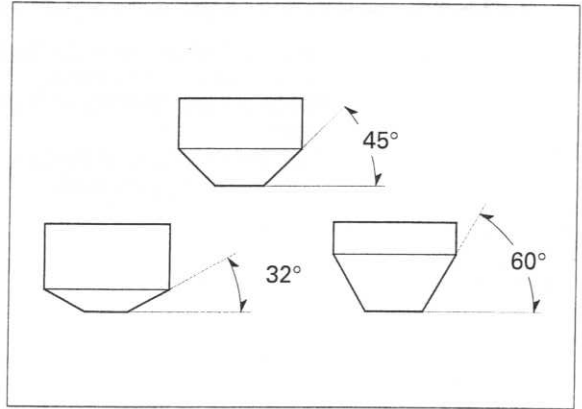

If the contact area is too high on the valve, the seat must be lowered using a 32° flat cutter.

If the contact area is too low on the valve, the seat must be raised using a 60° interior cutter.

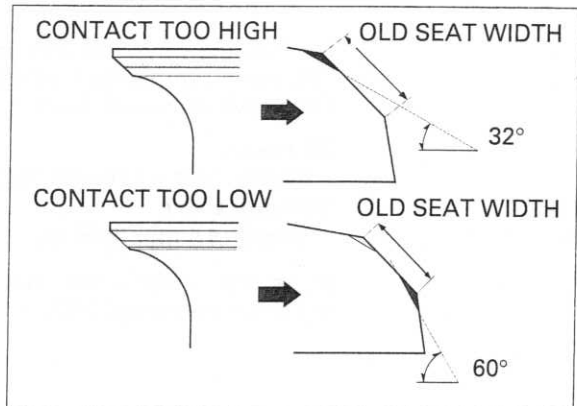

Reface the seat with a 45° cutter whenever a valve guide is replaced. Use a 45° cutter to remove any roughness or irregularities from the seat.

TOOLS:

- Seat cutter, 29 mm (IN)
- Seat cutter, 24 mm (EX)
- Cutter holder, 4.0 mm

07780-0010300
07780-0010600
07781-0010500
or equivalent commercially available in U.S.A.

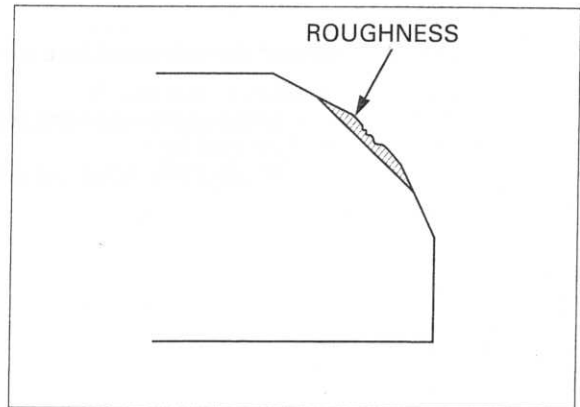

Use a 32° cutter to remove the top 1/4 of the existing valve seat material.

TOOLS:

- Flat cutter, 29 mm (IN)
- Flat cutter, 24 mm (EX)
- Cutter holder, 4.0 mm

07780-0013400
07780-0012500
07781-0010500
or equivalent commercially available in U.S.A.

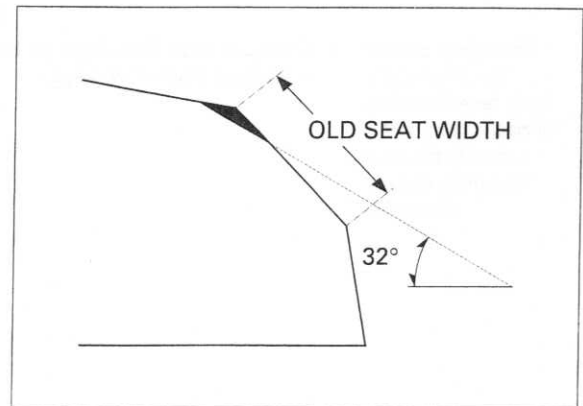

Use a 60° cutter to remove the bottom 1/4 of the old seat.

TOOLS:

Interior cutter, 30 mm (IN)
Interior cutter, 24 mm (EX)
Cutter holder, 4.0 mm

07780-0014000
070PH-Z0D0100
07781-0010500
or equivalent commercially available in U.S.A.

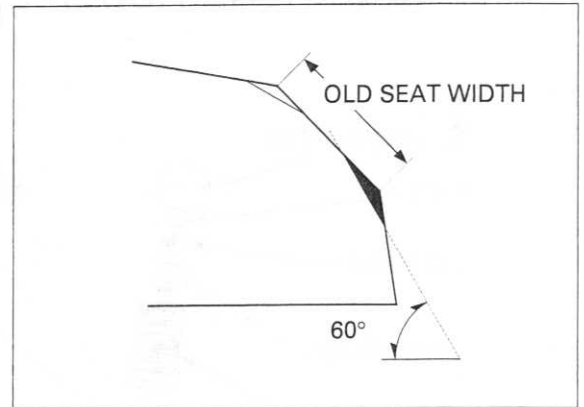

Using a 45° seat cutter, cut the seat to the proper width. Make sure that all pitting and irregularities are removed. Refinish if necessary.

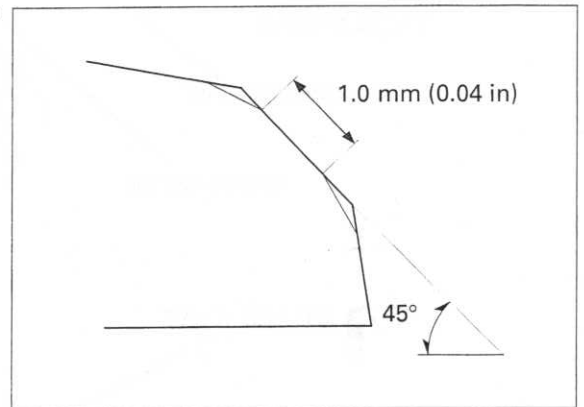

After cutting the seat, apply lapping compound to the valve face, and lap the valve using light pressure.

- Excessive lapping pressure may deform or damage the seat.
- Change the angle of lapping tool frequently to prevent uneven seat wear.
- Do not allow lapping compound to enter the guides.

After lapping, wash all residual compound off the cylinder head and valve.

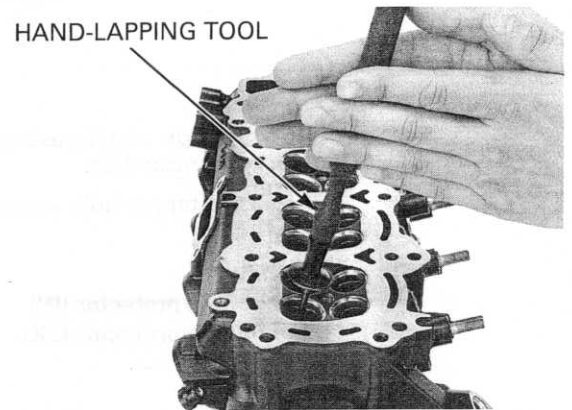

CYLINDER HEAD ASSEMBLY

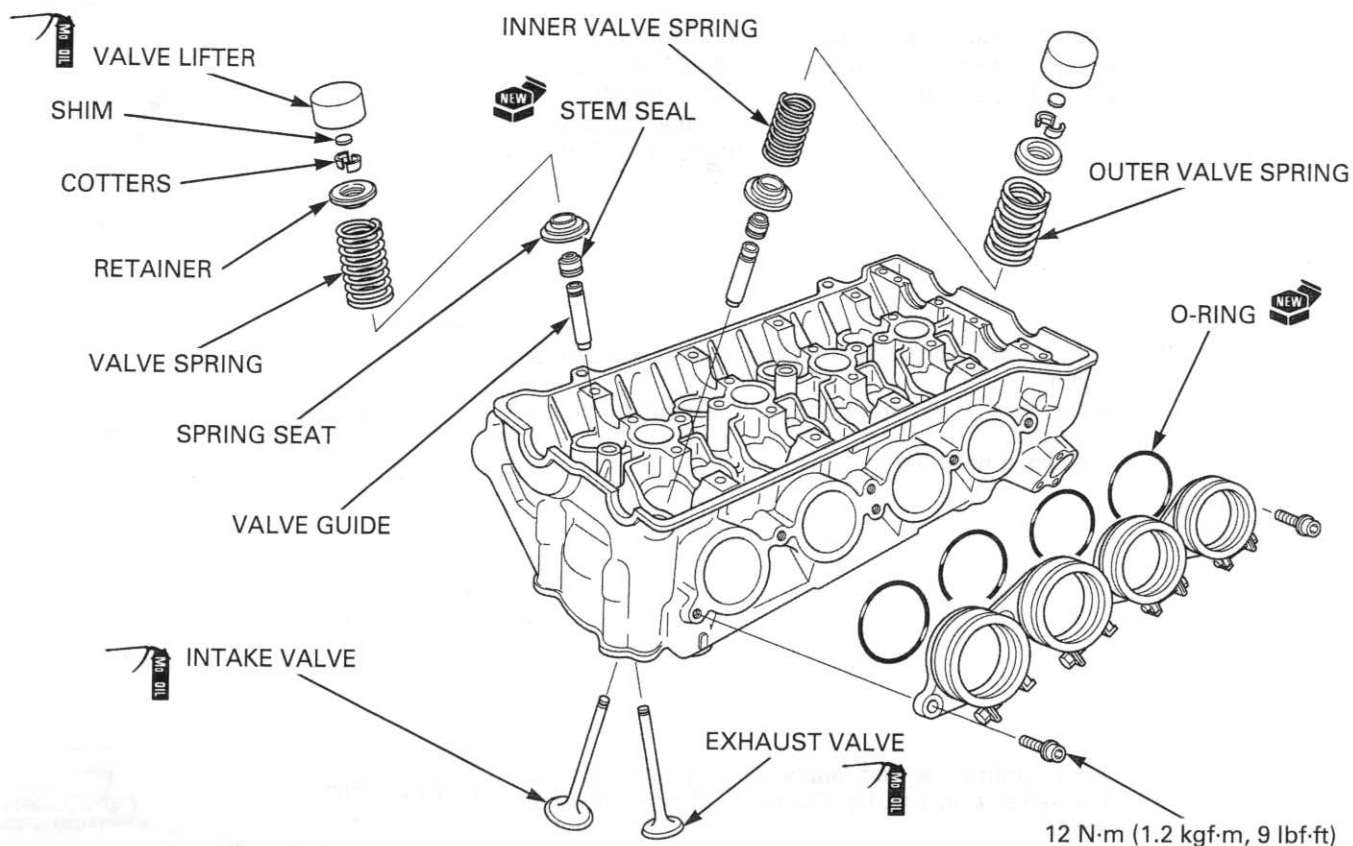

Blow through all oil passages in the cylinder head with compressed air.

Install the tappet hole protector into the valve lifter bore.

TOOLS:

- Tappet hole protector (IN)
- Tappet hole protector (EX)

07HMG-MR70002
07JMG-KY20100
Not available in U.S.A.

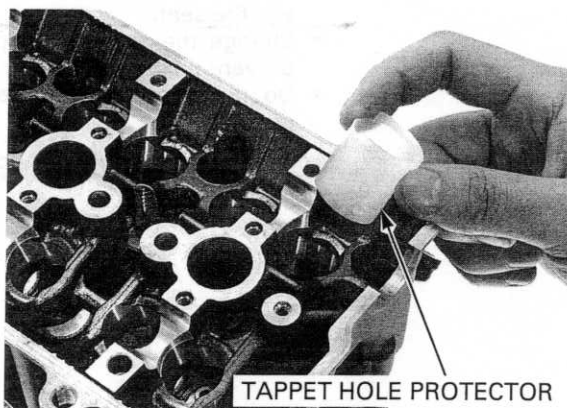

Install the valve spring seats.
Install new stem seals.

Lubricate the valve stems with molybdenum oil solution.
Insert the valve into the valve guide while turning it slowly to avoid damage to the stem seal.

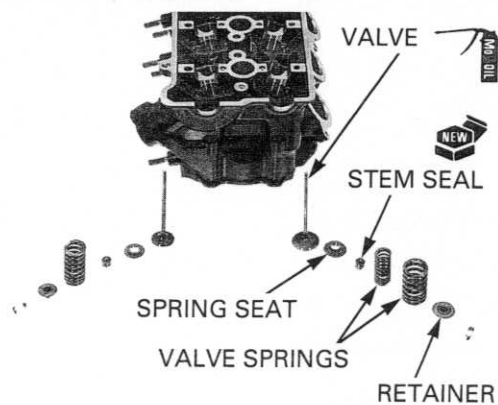

CYLINDER HEAD/VALVES

Install the valve springs with the tightly wound coils facing the combustion chamber.

- The valve springs have paint marks
 - IN (inner): Red
 - IN (outer): Pink
 - EX: Pink

Install the valve spring retainer.

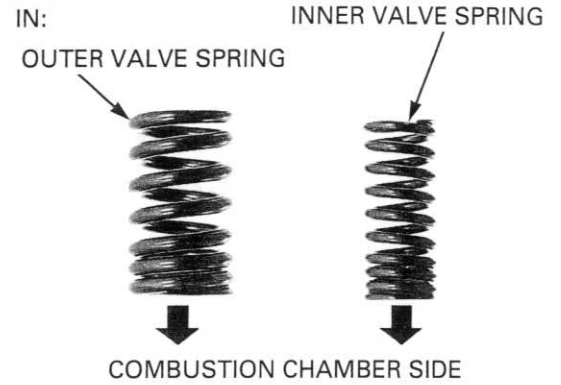

EX:



Grease the cotters to ease installation.

Install the valve cotters using the special tool as shown.

NOTE:

To prevent loss of tension, do not compress the valve spring more than necessary.

TOOLS:

Valve spring compressor 07757-0010000

Valve spring compressor attachment (IN) 07959-KM30101

Valve spring compressor attachment (EX) 07JME-KY20100

Support the cylinder head above the work bench surface to prevent possible valve damage.

Tap the valve stems gently with two plastic hammers as shown to seat the cotters firmly.

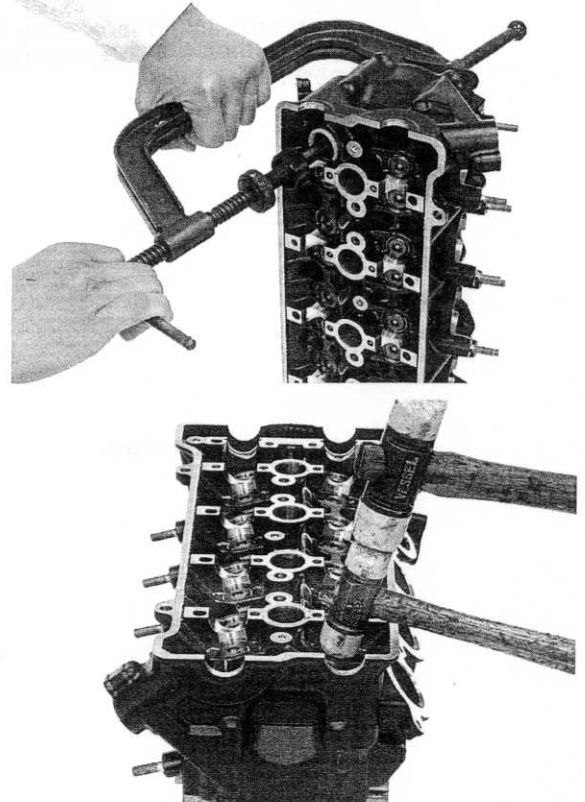

CYLINDER HEAD/VALVES

Apply locking agent to the cam chain tensioner B pivot bolt threads (page 1-19).

Install the sealing washer, bolt and cam chain tensioner B as shown.

Tighten the cam chain tensioner B pivot bolt to the specified torque.

TORQUE: 20 N·m (2.0 kgf·m, 15 lbf·ft)

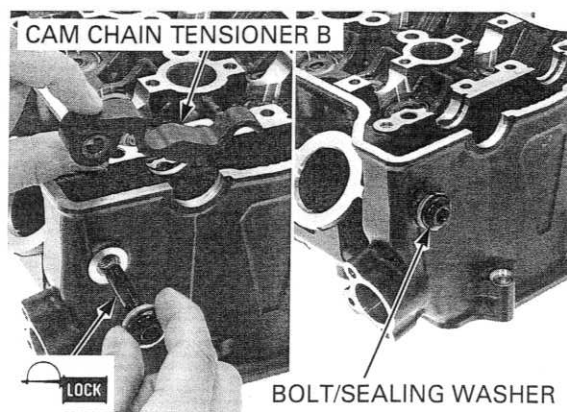

Install new O-rings to the insulator grooves.

Install the insulators to the cylinder head and tighten the bolts to the specified torque.

TORQUE: 12 N·m (1.2 kgf·m, 9 lbf·ft)

For spark plug installation (page 4-11).

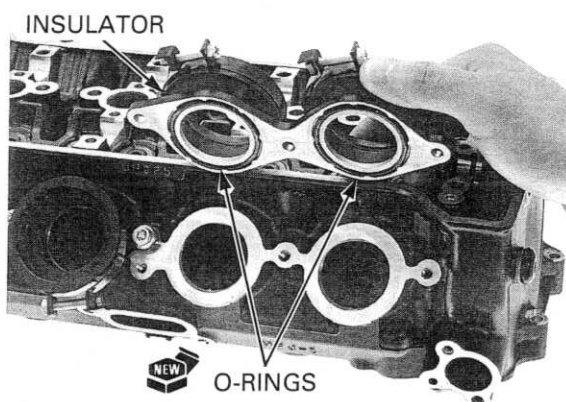

CYLINDER HEAD INSTALLATION

Install the timing sprocket by aligning the wide teeth between the crankshaft and sprocket.

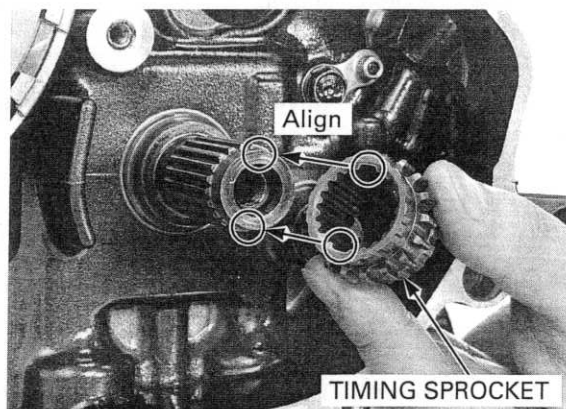

Install the cam chain.

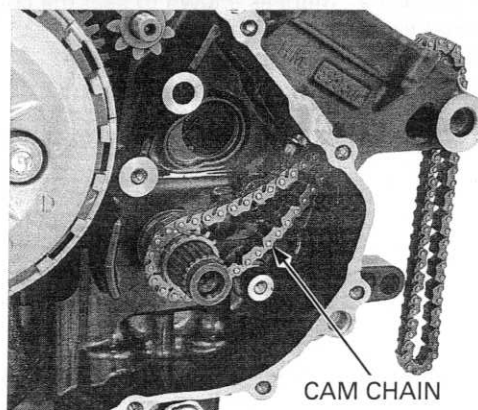

CYLINDER HEAD/VALVES

Install the cam chain guide A, bolt and washer.

CAM CHAIN GUIDE A



Apply locking agent to the cam chain tensioner A pivot bolt threads (page 1-19).
Install the collar, cam chain tensioner A and bolt.

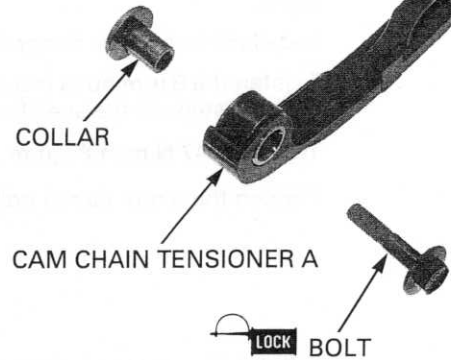

Tighten the cam chain guide A bolt to the specified torque.

TORQUE: 12 N·m (1.2 kgf·m, 9 lbf·ft)

Tighten the cam chain tensioner A pivot bolt to the specified torque.

TORQUE: 12 N·m (1.2 kgf·m, 9 lbf·ft)

Install the following:

- Starter clutch (page 10-21)
- Right crankcase cover (page 10-26)

Install the dowel pins and a new cylinder head gasket as shown.

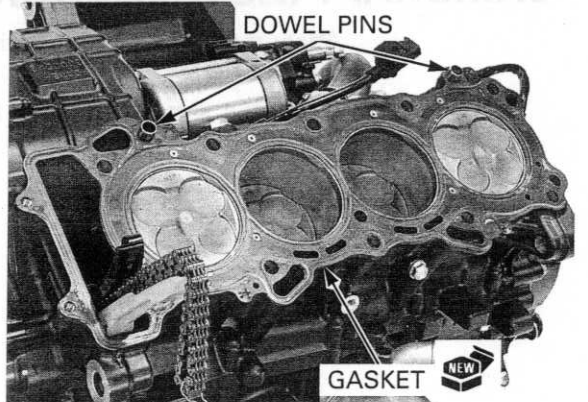
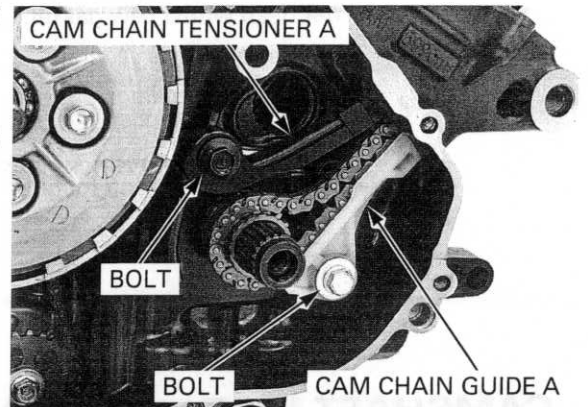

CYLINDER HEAD/VALVES

Install the cylinder head onto the cylinder block while aligning the cam chain tensioner A and B as shown.

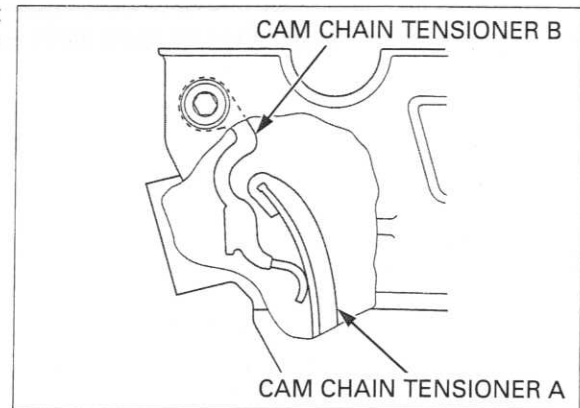

Apply molybdenum oil solution to the 9 mm bolts/washers threads and seating surface and install them.

Install the two 6 mm flange bolts.

Tighten the 9 mm bolts in a crisscross pattern in two or three steps to the specified torque.

TORQUE: 47 N·m (4.8 kgf·m, 35 lbf·ft)

Tighten the 6 mm flange bolts.

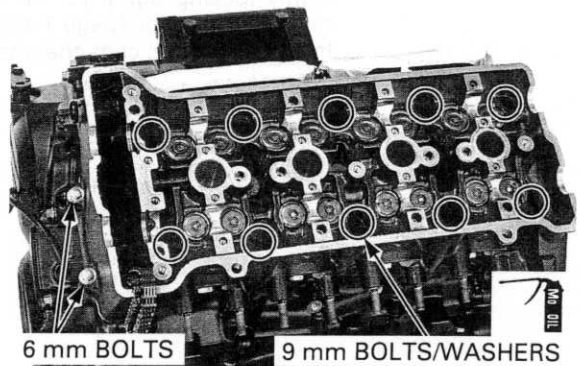

Install the cam chain tensioner lifter onto the cylinder head with a new gasket.

Tighten the bolts securely.

Install the following:

- Camshaft (page 9-28)
- Thermostat housing (page 7-10)

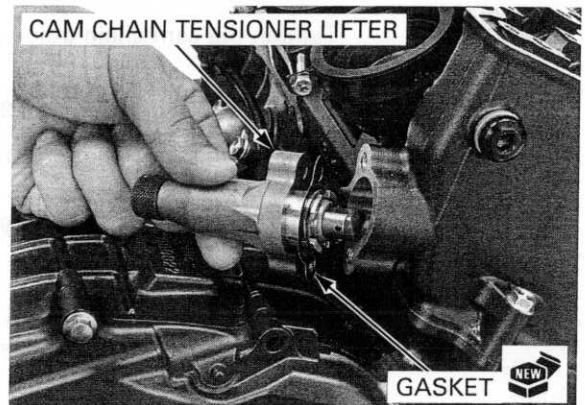

CAMSHAFT INSTALLATION

Apply molybdenum oil solution to the sliding surface of each valve lifter.

Install the shims and valve lifters in their original locations.

Install the shims and valve lifters to the cylinder head.

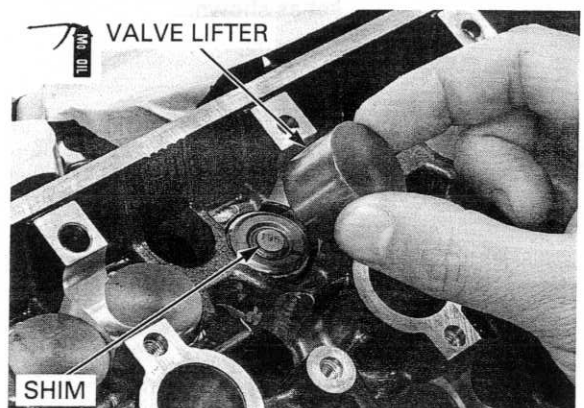

CYLINDER HEAD/VALVES

Each camshaft has an identification mark.

- "IN": Intake camshaft
- "EX": Exhaust camshaft

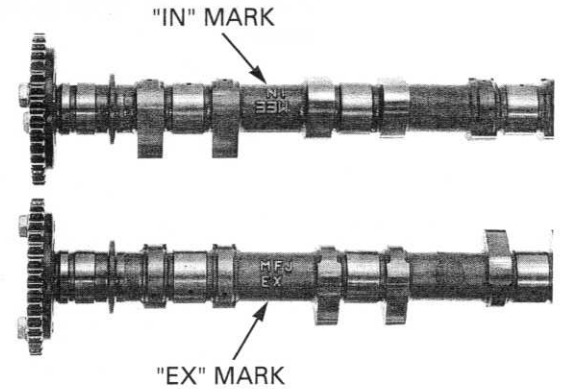

If the cam sprockets are removed, install the cam sprockets onto the camshafts.

- Install the intake cam sprocket with the timing mark (IN) facing outward and the No.1 cam lobes facing up and out as shown.
- Install the exhaust cam sprocket with the timing mark (EX) facing outward and the No.1 cam lobes facing up and out as shown.

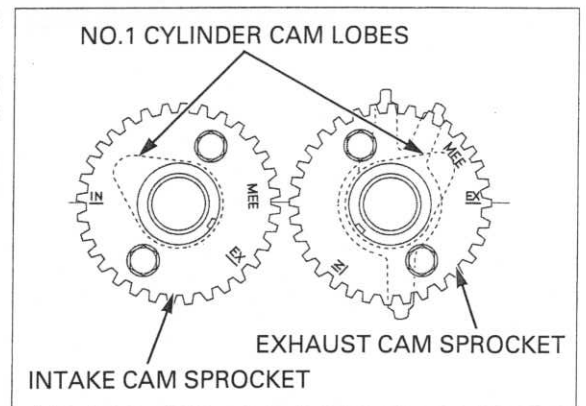

Clean and apply locking agent to the cam sprocket bolt threads (page 1-19).
Temporarily install the cam sprockets and bolts.

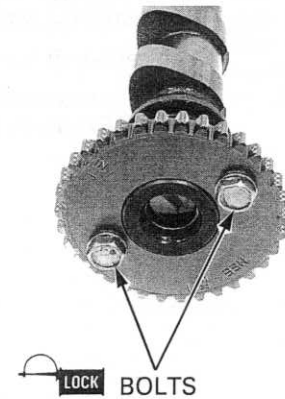

Exhaust camshaft only: Clean and apply locking agent to the CMP sensor rotor bolt threads.

Install the CMP sensor rotor with the No.1 cylinder cam lobes facing down and rotor "OUT" mark facing up as shown. Install the CMP sensor rotor and bolts.

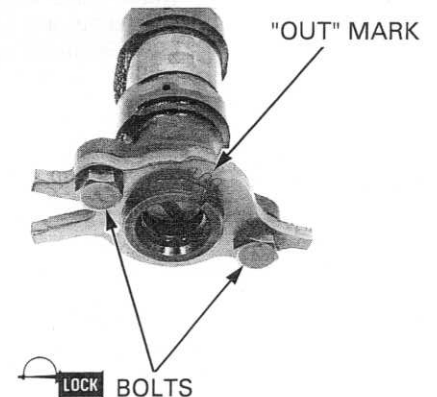

CYLINDER HEAD/VALVES

Turn the crankshaft clockwise and align the "T" mark with the index mark on the right crankcase cover.

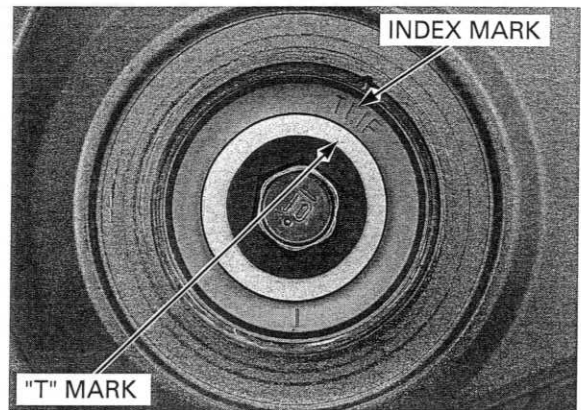

Apply molybdenum oil solution to the camshaft journal of the cylinder head.

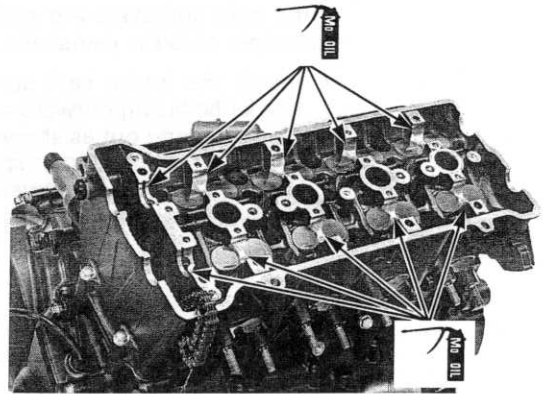

INTAKE CAMSHAFT

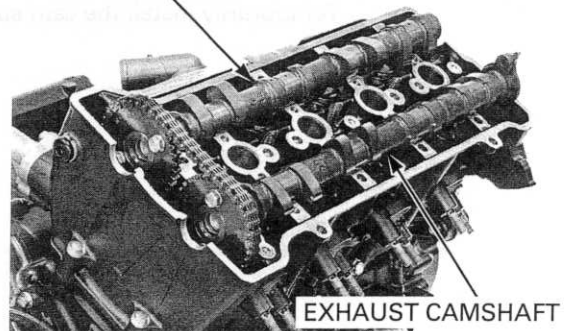

CYLINDER HEAD UPPER SURFACE

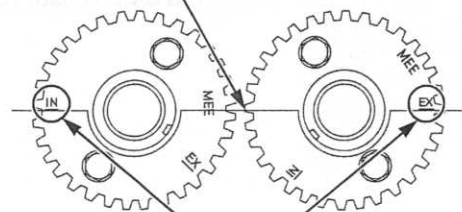

TIMING MARKS

Make sure the cam chain tensioner is fully retracted with the tensioner stopper (page 9-11).

Install the cam chain over the cam sprockets and then install the intake and exhaust camshafts.

Each camshaft has an identification mark.

- "IN": Intake camshaft
- "EX": Exhaust camshaft

- Make sure that the timing marks on the cam sprockets are facing outward and flush with the cylinder head upper surface as shown.

CYLINDER HEAD/VALVES

Coat new O-rings with oil and install them into the grooves in the camshaft holders.

Apply molybdenum oil solution to the camshaft journals of the camshaft holders.

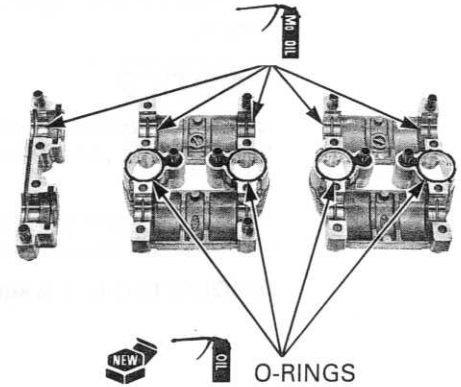

Note the correct locations with the identification marks as shown.

- No mark: right camshaft holder
- "R" mark: center camshaft holder
- "L" mark: left camshaft holder

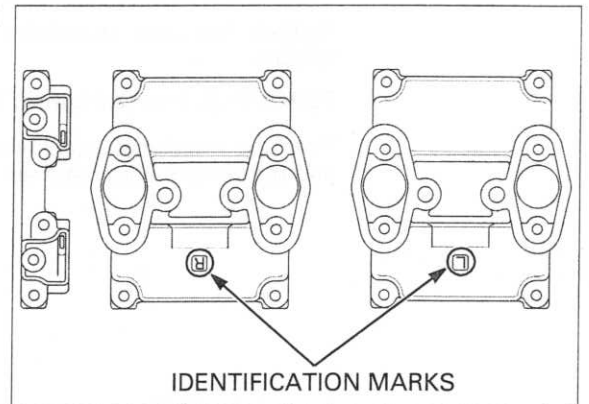

Be sure to align the dowel pins in the camshaft holder with the holes in the cylinder head. Install each camshaft holder onto the camshafts.

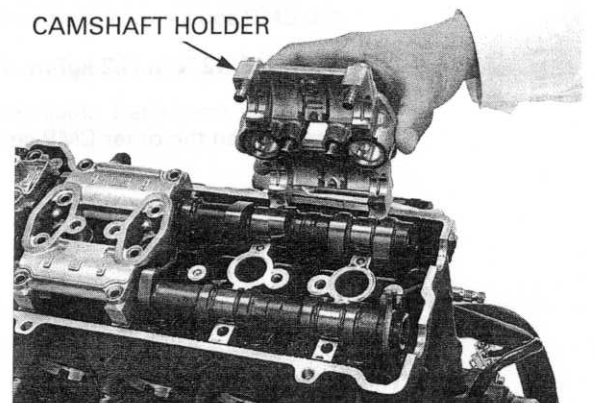

Apply oil to the threads and seating surfaces of the camshaft holder bolts. Install the twenty holder bolts with new eight sealing washers as shown.

Finger tighten the bolts.

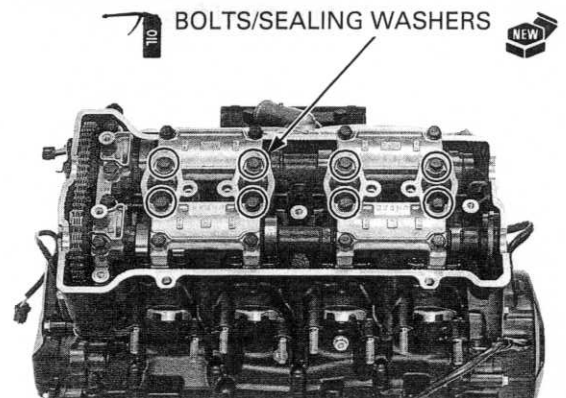

CYLINDER HEAD/VALVES

Gradually tighten the camshaft holder bolts until the camshaft holders lightly contact the cylinder head surface.

NOTICE

Failure to tighten the camshaft holder in a criss-cross pattern might cause a camshaft holder to break.

Tighten all camshaft holder bolts in the numerical order cast on the camshaft holders.

TORQUE: 12 N·m (1.2 kgf·m, 9 lbf·ft)

BOLTS

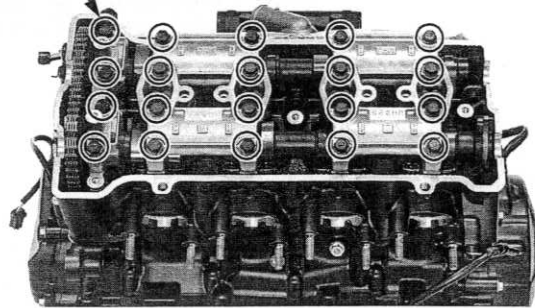

Install the cam chain guide B, and tighten the bolts.

Tighten the cam sprocket bolts to the specified torque.

TORQUE: 20 N·m (2.0 kgf·m, 15 lbf·ft)

Turn the crankshaft clockwise one full turn (360°) and tighten the other cam sprocket bolts.

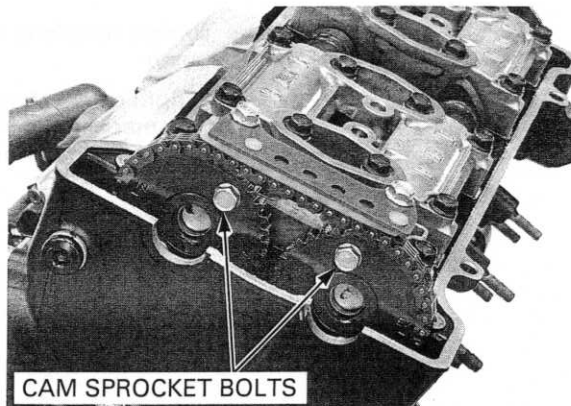

In case the CMP sensor rotor was removed, tighten the CMP sensor rotor bolt to the specified torque.

TORQUE: 12 N·m (1.2 kgf·m, 9 lbf·ft)

Turn the crankshaft clockwise one full turn (360°) and tighten the other CMP sensor rotor bolt.

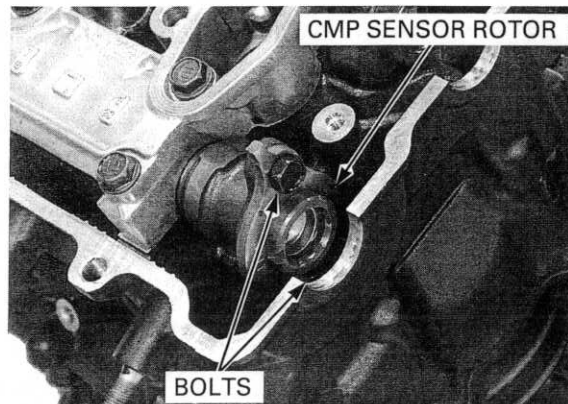

Remove the tensioner stopper from the cam chain tensioner lifter.

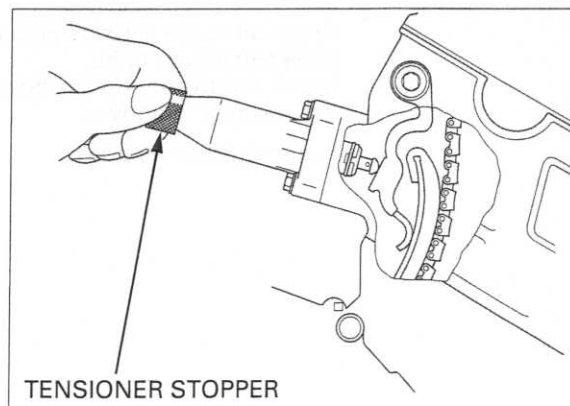

Install a new sealing washer and tighten the bolt securely.

Recheck the valve timing.

Install the CMP sensor (page 6-72).

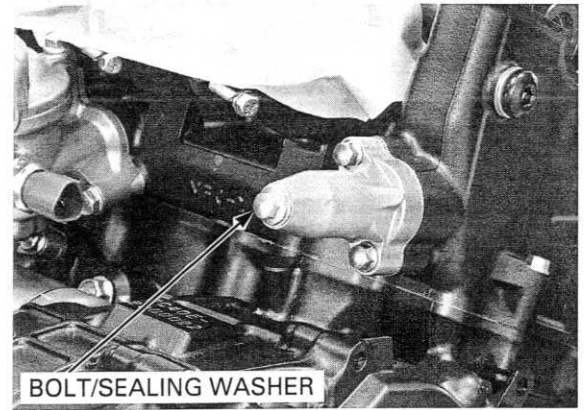

CYLINDER HEAD COVER ASSEMBLY

Install the PAIR check valve baffle plates into the cylinder head cover.

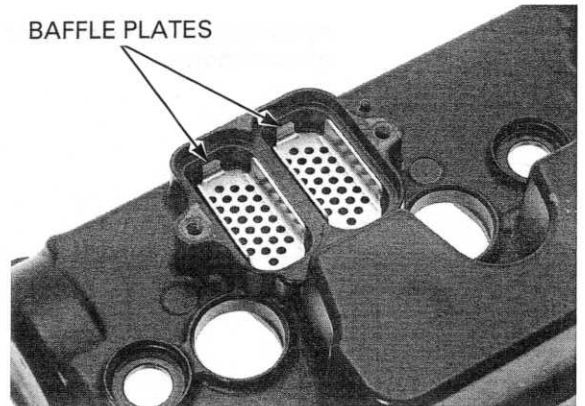

Install the PAIR check valves into the cylinder head cover.

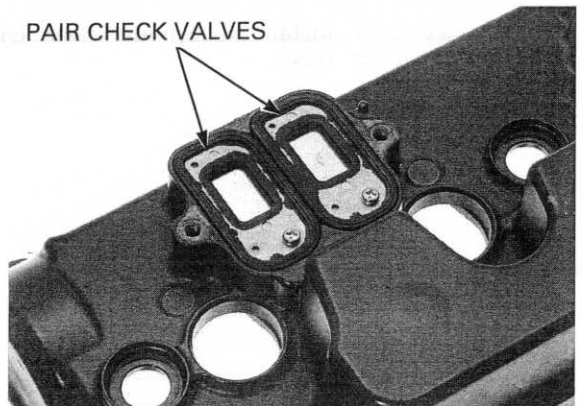

Apply locking agent to the PAIR check valve cover bolt threads.

Install the PAIR check valve cover and tighten the bolts to the specified torque.

TORQUE: 12 N·m (1.2 kgf·m, 9 lbf·ft)

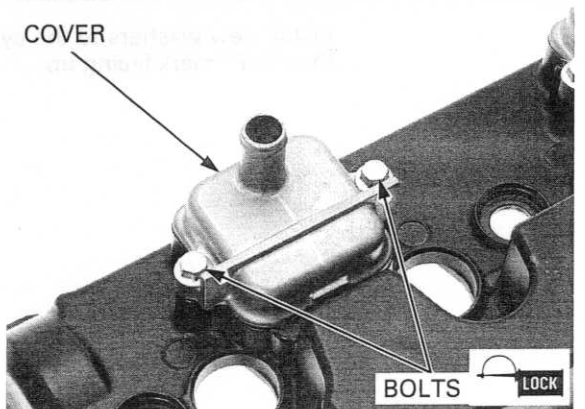

CYLINDER HEAD/VALVES

CYLINDER HEAD COVER INSTALLATION

Install a new cylinder head packing into the groove of the cylinder head cover.

 PACKING

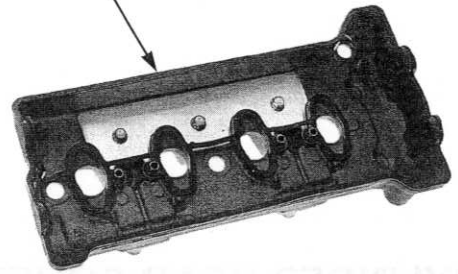

Apply sealant to the cylinder head semi-circular cut-outs as shown.

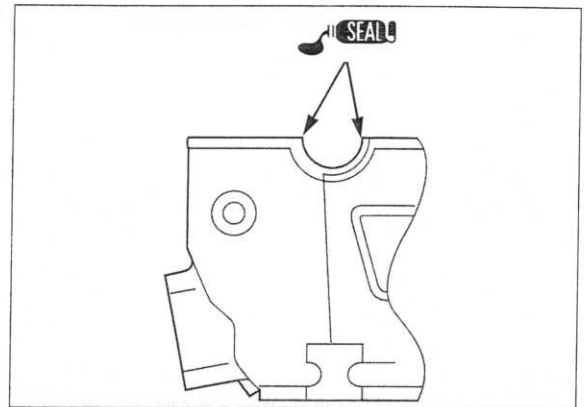

Be careful not to damage the radiator fins.

Install the cylinder head cover onto the cylinder head.

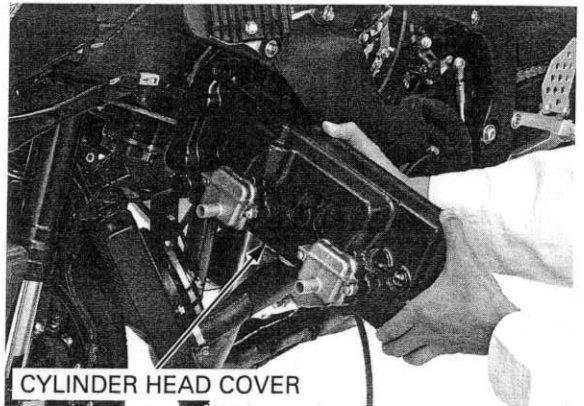

CYLINDER HEAD COVER

Install new washers to the cylinder head cover with their "UP" mark facing up.

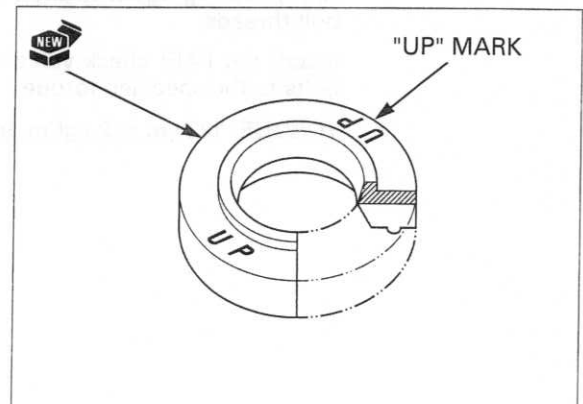

Install and tighten the cylinder head cover bolts to the specified torque.

TORQUE: 10 N·m (1.0 kgf·m, 7 lbf·ft)

BOLTS

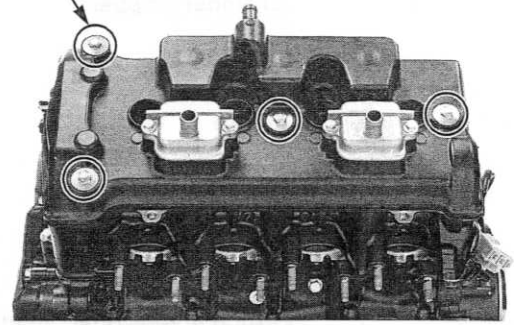

Install the right heat guard plate and trim clip.

TRIM CLIP

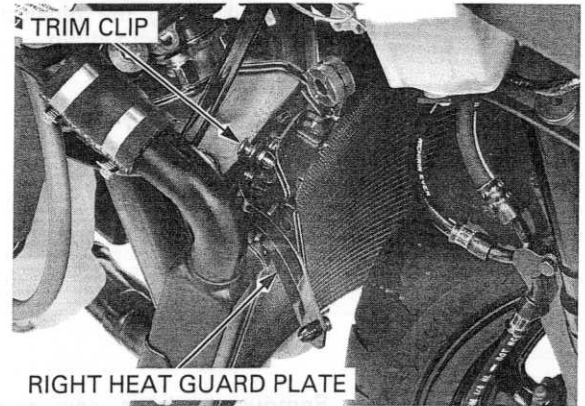

RIGHT HEAT GUARD PLATE

Connect the breather hose securely.

Install the following:

- Direct ignition coils (page 4-11)
- PAIR control solenoid valve (page 6-78)
- Air cleaner housing (page 6-54)

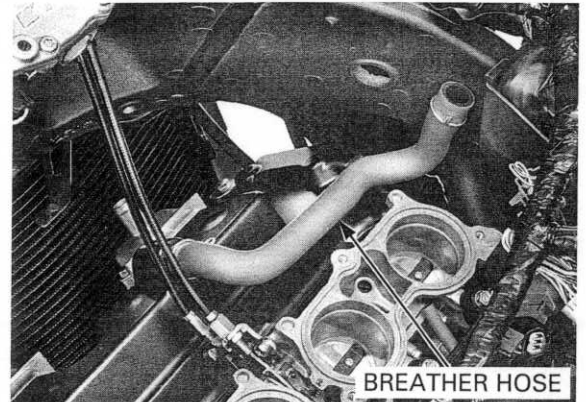

BREATHER HOSE

CAM CHAIN TENSIONER LIFTER

REMOVAL

Lift and support the fuel tank (page 4-5).

Remove the cam chain tensioner sealing bolt and sealing washer.

BOLT/SEALING WASHER

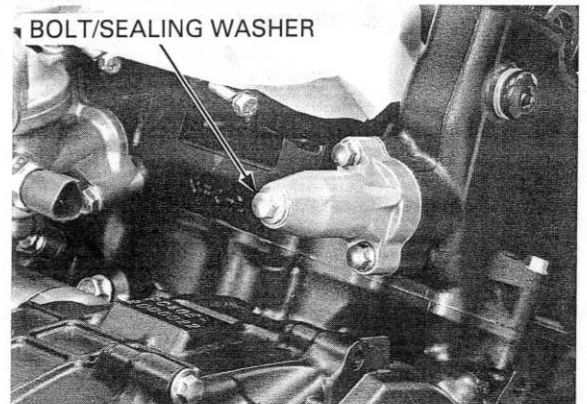

CYLINDER HEAD/VALVES

Use a 1.5 mm hex wrench to remove the screw and end piece from the tensioner stopper.

TOOL:
Tensioner stopper

070MG-0010100

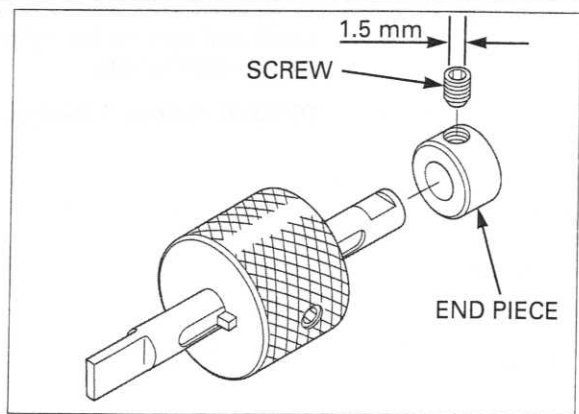

Turn the tensioner shaft fully in (clockwise) and secure it using the tensioner stopper to prevent damaging the cam chain.

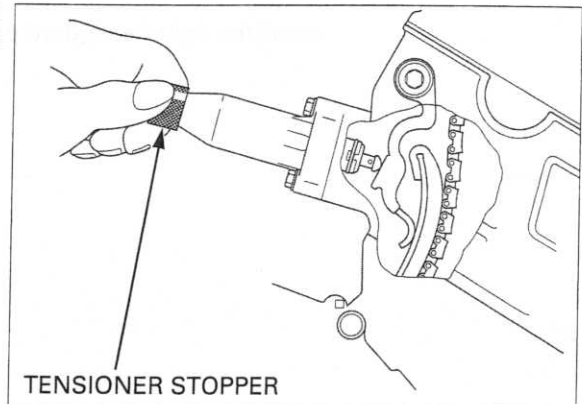

Remove the bolts, cam chain tensioner lifter and gasket.

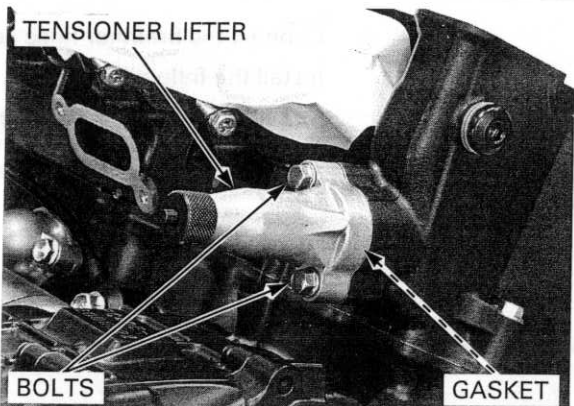

INSTALLATION

Note the installation direction of the gasket.

Install a new gasket onto the cam chain tensioner lifter.

Install the cam chain tensioner lifter into the cylinder head.

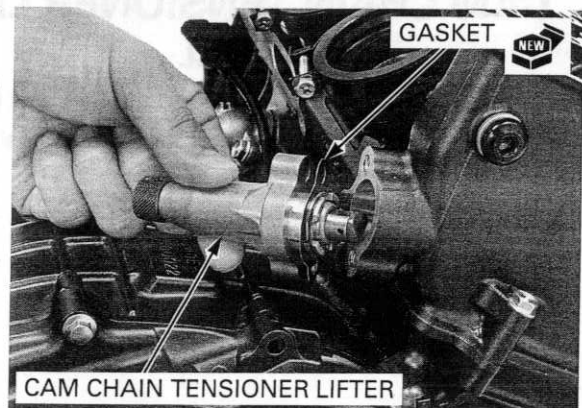

Install and tighten the bolts securely.
Remove the tensioner stopper.

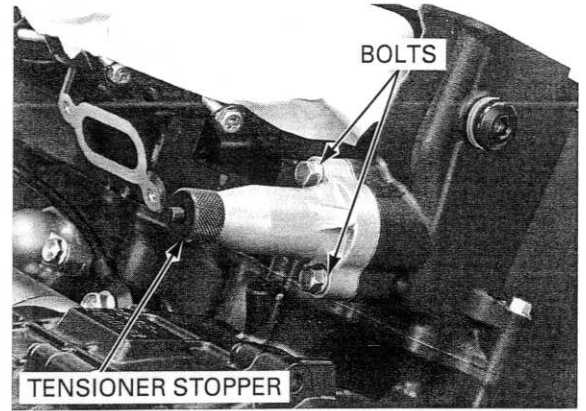

Install a new sealing washer and tighten the sealing bolt securely.
Remove the suitable support and close the fuel tank (page 4-6).



MEMO

10. CLUTCH/STARTER CLUTCH/GEARSHIFT LINKAGE

COMPONENT LOCATION	10-2	CLUTCH	10-7
SERVICE INFORMATION	10-3	STARTER CLUTCH	10-17
TROUBLESHOOTING	10-4	GEARSHIFT LINKAGE	10-23
RIGHT CRANKCASE COVER REMOVAL	10-5	RIGHT CRANKCASE COVER INSTALLATION	10-26



CLUTCH/STARTER CLUTCH/GEARSHIFT LINKAGE

COMPONENT LOCATION

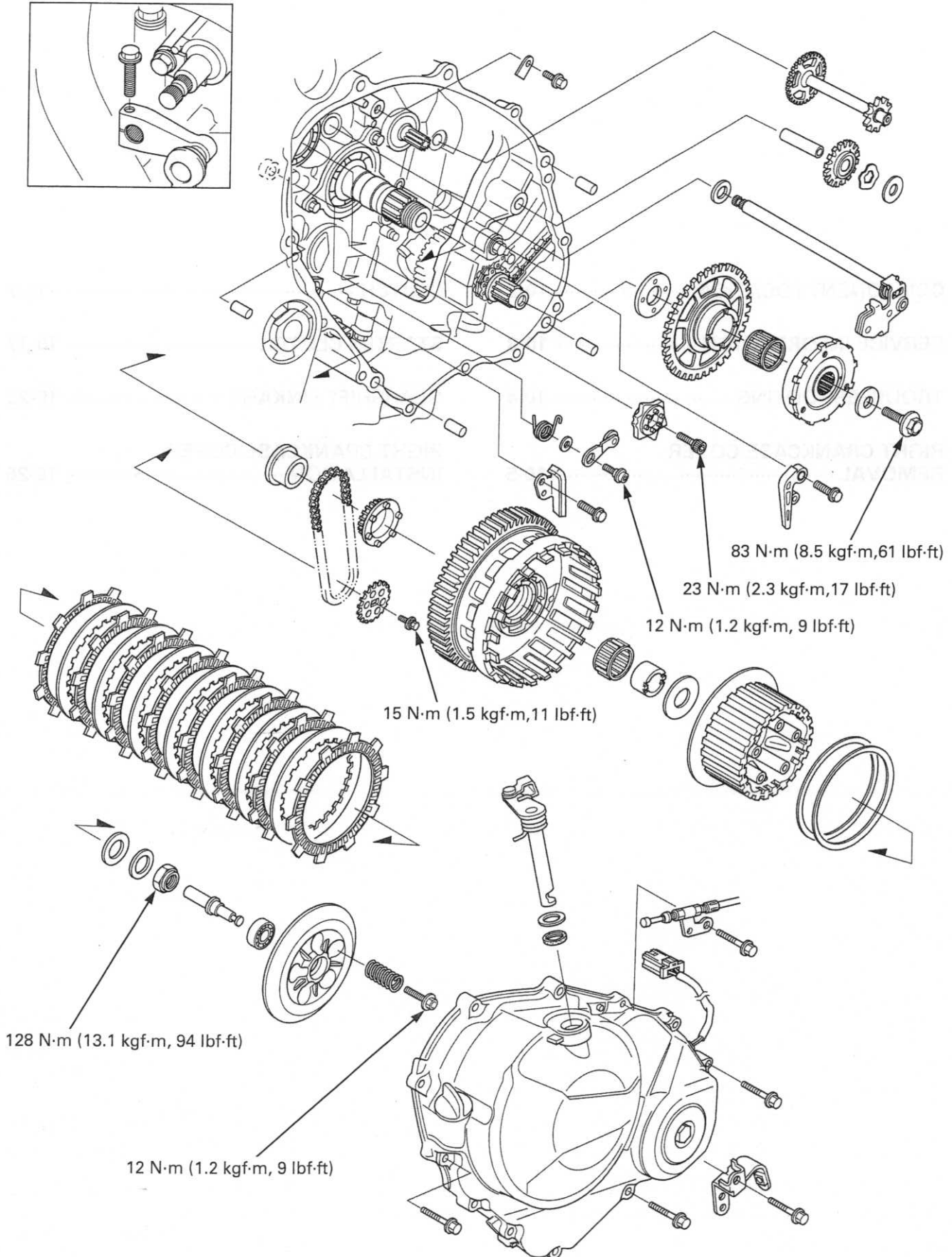

SERVICE INFORMATION

GENERAL

- This section covers service of the clutch, starter clutch and gearshift linkage. All service can be done with the engine installed in the frame.
- Engine oil viscosity and level have an effect on clutch disengagement. When the clutch does not disengage or the motorcycle creeps with clutch disengaged, inspect the engine oil level before servicing the clutch system.

SPECIFICATIONS

ITEM		STANDARD	SERVICE LIMIT
Clutch lever freeplay		10 – 20 (3/8 – 13/16)	–
Clutch	Spring free length	46.7 (1.84)	45.8 (1.80)
	Disc thickness	2.92 – 3.08 (0.115 – 0.121)	2.6 (0.10)
	Plate warp	–	0.30 (0.012)
Clutch outer guide	I.D.	24.993 – 25.003 (0.9840 – 0.9844)	25.013 (0.9848)
	O.D.	34.996 – 35.004 (1.3778 – 1.3781)	34.986 (1.3774)
Primary driven gear I.D.		41.000 – 41.016 (1.6142 – 1.6148)	41.026 (1.6152)
Oil pump drive sprocket guide	I.D.	25.000 – 25.021 (0.9843 – 0.9851)	25.031 (0.9855)
	O.D.	34.950 – 34.975 (1.3760 – 1.3770)	34.940 (1.3756)
Oil pump drive sprocket I.D.		35.025 – 35.145 (1.3789 – 1.3837)	35.155 (1.3841)
Mainshaft O.D. at clutch outer guide		24.980 – 24.990 (0.9835 – 0.9839)	24.960 (0.9827)
Mainshaft O.D. at oil pump drive sprocket guide		24.980 – 24.990 (0.9835 – 0.9839)	24.960 (0.9827)
Starter driven gear boss O.D.		45.657 – 45.673 (1.7975 – 1.7981)	45.642 (1.7969)



Unit: mm (in)

TORQUE VALUES

Clutch center lock nut	128 N·m (13.1 kgf·m, 94 lbf·ft)	Apply oil to the thread and seating surface, stake
Clutch spring bolt	12 N·m (1.2 kgf·m, 9 lbf·ft)	
Oil pump driven sprocket bolt	15 N·m (1.5 kgf·m, 11 lbf·ft)	Apply locking agent to the threads
Shift drum center bolt	23 N·m (2.3 kgf·m, 17 lbf·ft)	Apply locking agent to the threads
Shift drum stopper arm pivot bolt	12 N·m (1.2 kgf·m, 9 lbf·ft)	Apply locking agent to the threads
Gearshift spindle stopper pin	22 N·m (2.2 kgf·m, 16 lbf·ft)	
Starter clutch mounting bolt	83 N·m (8.5 kgf·m, 61 lbf·ft)	Apply oil to the threads and seating surface

CLUTCH/STARTER CLUTCH/GEARSHIFT LINKAGE

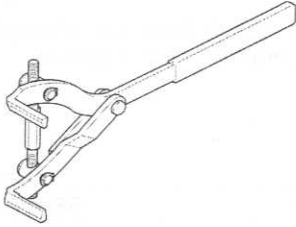
TOOLS

<p>Clutch center holder 07724-0050002</p>  <p>or equivalent commercially available in U.S.A.</p>	<p>Gear holder, M2.5 07724-0010100</p>  <p>or 07724-001A100 (U.S.A. only)</p>
---	--

TROUBLESHOOTING

Clutch lever is too hard to pull in

- Damaged clutch lifter mechanism
- Faulty clutch lifter bearing
- Clutch lifter piece installed improperly

Clutch slips when accelerating

- Worn clutch disc
- Weak clutch springs
- Engine oil mixed with molybdenum or graphite additive

Clutch will not disengage or motorcycle creeps with clutch disengaged

- Clutch plate warped
- Loose clutch center lock nut
- Oil level too high
- Improper oil viscosity
- Damaged clutch lifter mechanism
- Clutch lifter piece installed improperly

Hard to shift

- Improper clutch operation
- Improper oil viscosity
- Bent shift fork
- Bent shift fork shaft (page 12-8)
- Bent fork claw (page 12-8)
- Damaged gearshift cam
- Loose stopper plate bolt
- Damaged stopper plate and pin
- Damaged gearshift spindle

Transmission jumps out of gear

- Worn shift drum stopper arm
- Weak or broken shift drum stopper arm return spring
- Loose stopper plate bolt
- Bent shift fork shaft
- Damaged gearshift cam
- Damaged or bent shift forks (page 12-8)
- Worn gear engagement dogs or slots (page 12-9)

Gearshift pedal will not return

- Weak or broken gearshift spindle return spring
- Bent gearshift spindle

Engine does not turn

- Faulty starter clutch
- Damaged reduction gear/shaft
- Damaged idle gear/shaft

RIGHT CRANKCASE COVER REMOVAL

Remove the following:

- Lower cowl (page 3-6)
- Middle cowls (page 3-8)
- Radiator reserve tank (page 7-20)

Drain the engine oil (page 4-17).

Lift and support the fuel tank (page 4-5).

Disconnect the CKP sensor 2P (Black) connector.

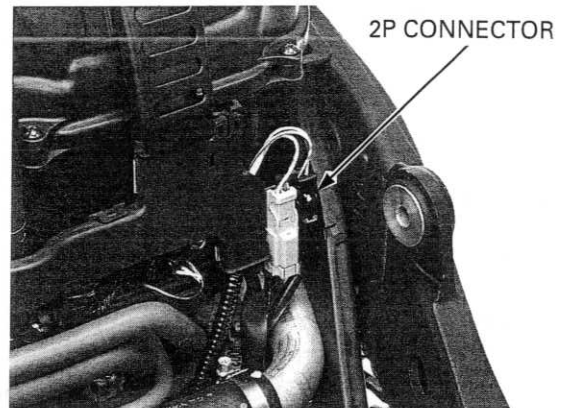

Remove the bolt and clutch cable guide plate, then disconnect the clutch cable end from the clutch lifter lever.

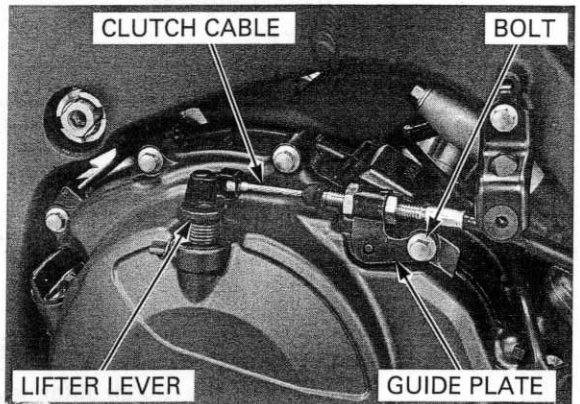

Remove the right crankcase cover bolts and stays.

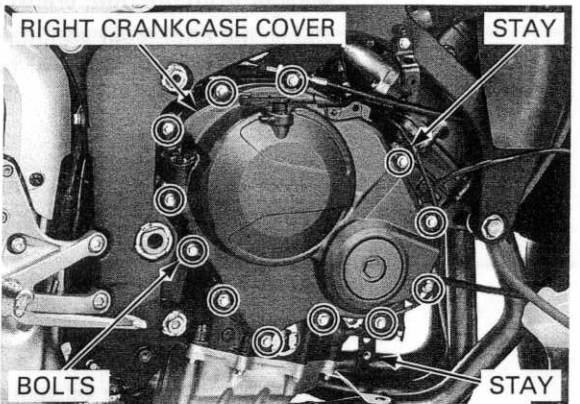

The lifter lever spindle is engaged with the clutch lifter piece inside of the right crankcase cover.

Remove the right crankcase cover while turning the clutch lifter lever counterclockwise to disengage the lifter lever spindle from the lifter piece.

NOTE:

Be careful not to drop the thrust/wave washers into the oil pan when removing the right crankcase cover.

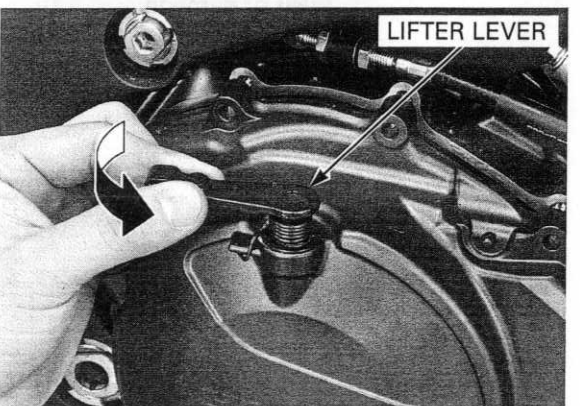

CLUTCH/STARTER CLUTCH/GEARSHIFT LINKAGE

Be careful not to drop the thrust/wave washers into the oil pan.

Remove the thrust washer and wave washer from the starter idle gear.

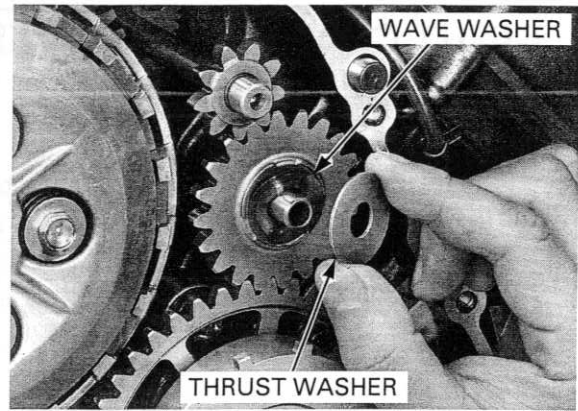

Remove the four dowel pins.

Clean off any sealant from the right crankcase cover mating surfaces.

NOTE:

Do not turn the crankshaft counterclockwise after removing the right crankcase cover to prevent the starter reduction gear from damage.

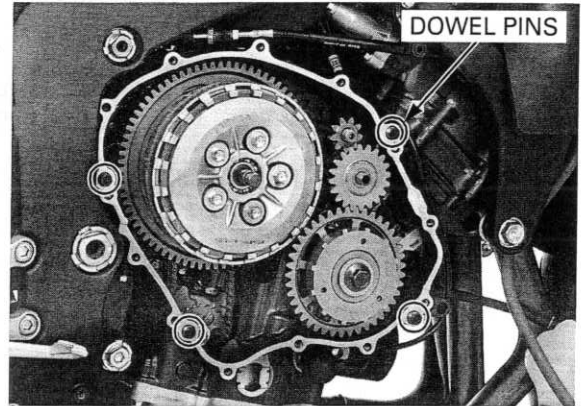

CLUTCH LIFTER LEVER

Remove the clutch lifter lever, return spring and washer from the right crankcase cover.

Check the lifter lever spindle for wear or damage. Check the return spring for fatigue or damage.

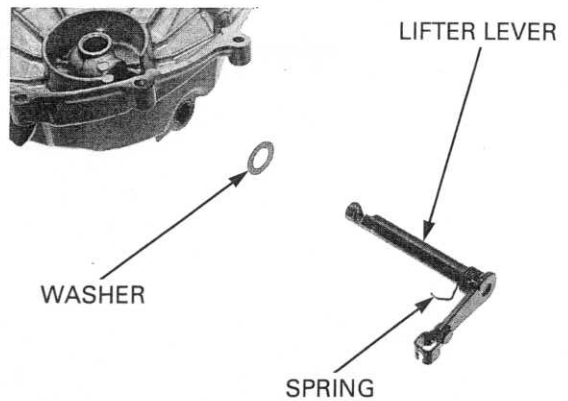

Check the lifter lever oil seal and needle bearings for wear or damage.

Install the clutch lifter lever with the washer and spring in the reverse order of removal.

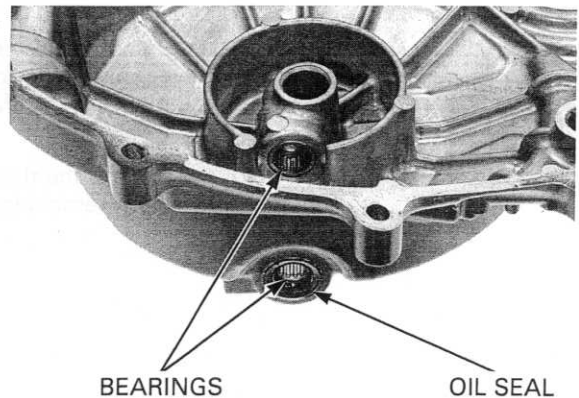

CLUTCH**REMOVAL**

Remove the right crankcase cover (page 10-5).

Remove the starter idle gear and shaft.

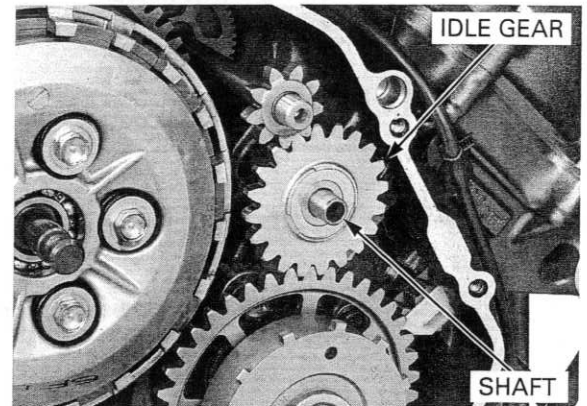

Remove the clutch spring bolts, springs in a criss-cross pattern in two or three steps, then remove the pressure plate.

Remove the clutch lifter piece from the lifter bearing.

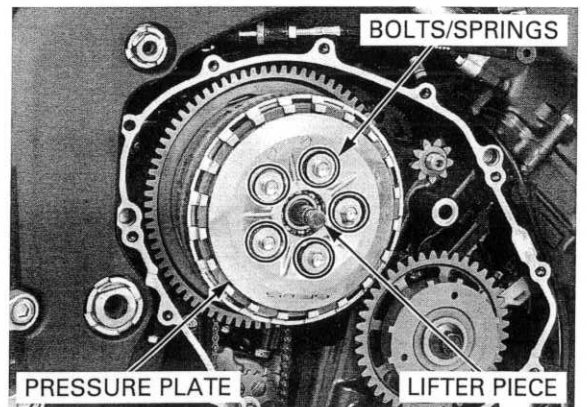

Remove the following:

- Clutch disc A
- Six clutch discs C
- Seven clutch plates
- Clutch disc B
- Judder spring
- Spring seat

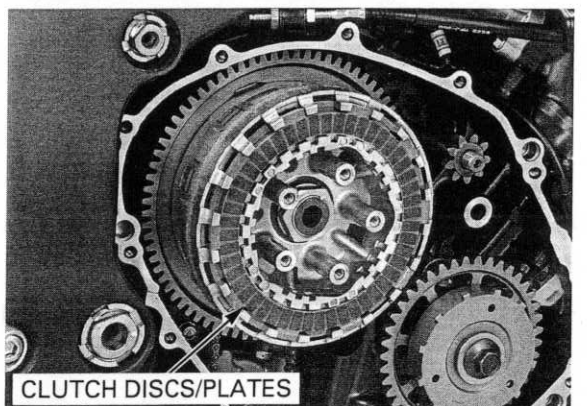

Be careful not to damage the mainshaft threads.

Unstake the clutch center lock nut.

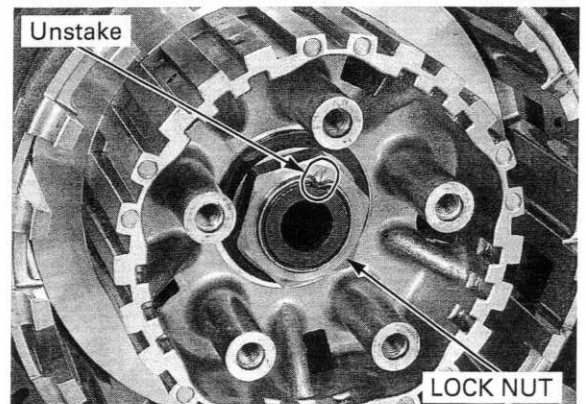

CLUTCH/STARTER CLUTCH/GEARSHIFT LINKAGE

Hold the clutch center with the special tool and remove the clutch center lock nut.

TOOL:

Clutch center holder

07724-0050002 or equivalent commercially available in U.S.A.

Discard the lock nut.

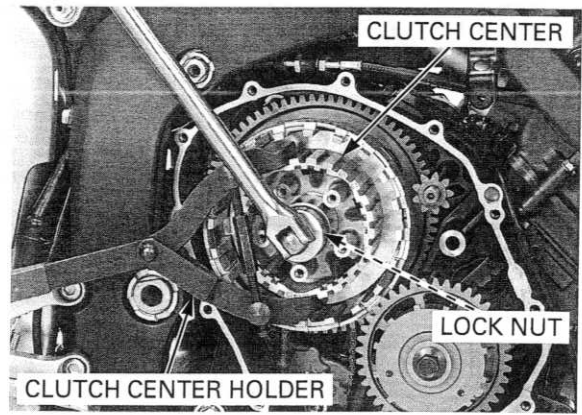

Remove the lock washer, thrust washer and clutch center.

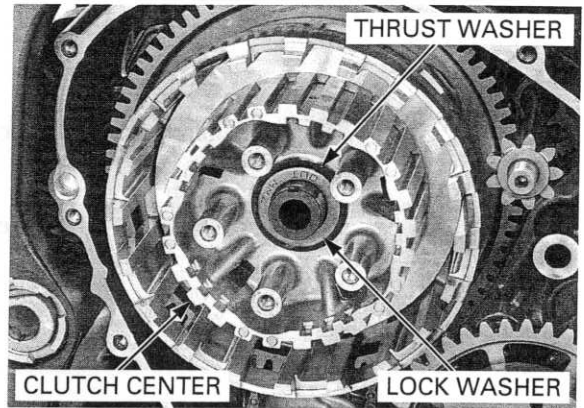

Remove the thrust washer.

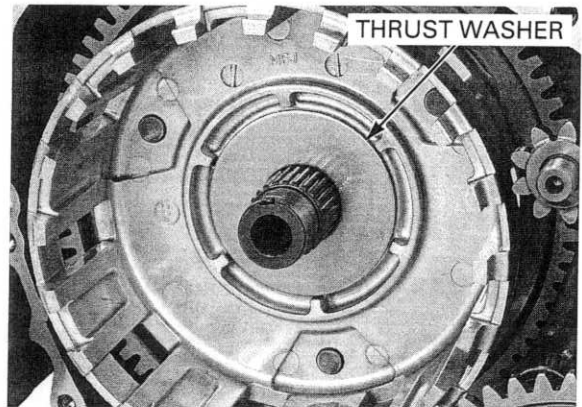

Remove the clutch outer guide and needle bearing.

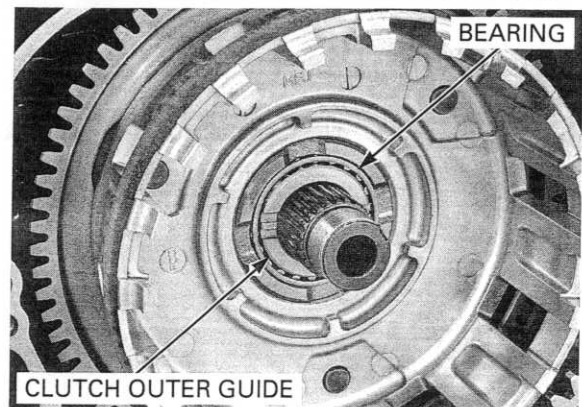

CLUTCH/STARTER CLUTCH/GEARSHIFT LINKAGE

Remove the clutch outer.

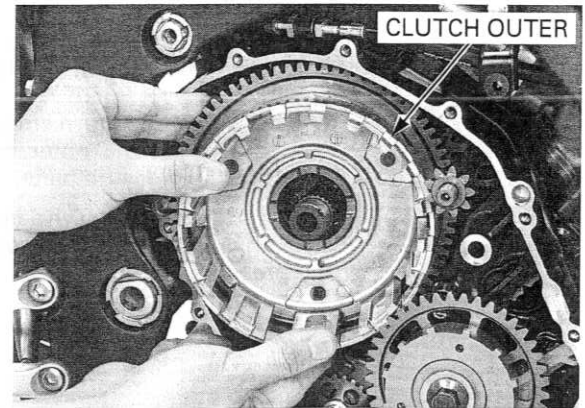

Be careful not to drop the parts into the oil pan.

Remove the bolts, oil pump drive chain guide A and chain guide B.

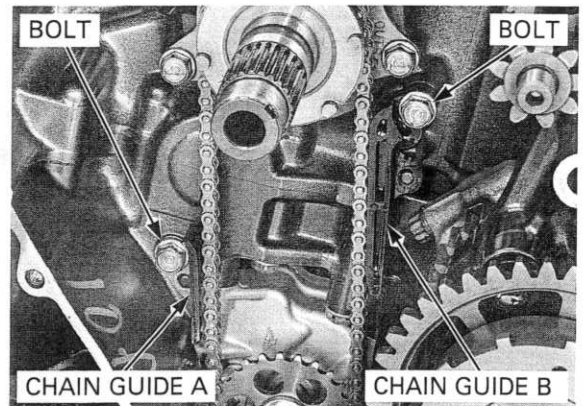

Be careful not to drop the parts into the oil pan.

Remove the oil pump driven sprocket bolt and washer. Remove the oil pump drive/driven sprocket and drive chain as an assembly.

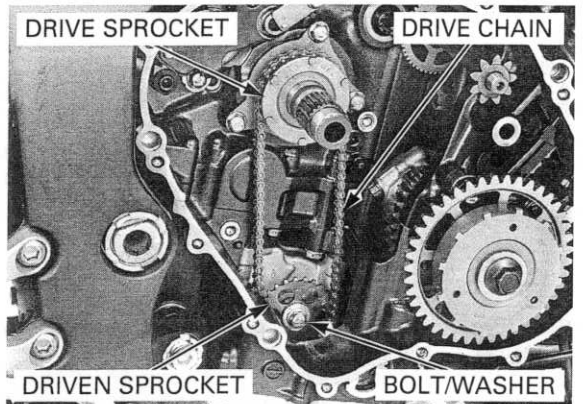

Remove the oil pump drive sprocket guide.

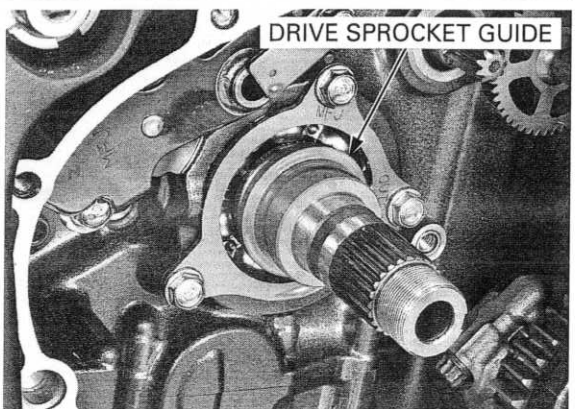

CLUTCH/STARTER CLUTCH/GEARSHIFT LINKAGE

INSPECTION

Clutch lifter bearing

Turn the inner race of the lifter bearing with your finger.
The bearing should turn smoothly and quietly.
Also check that the outer race of the bearing fits tightly in the pressure plate.

Replace the bearing if the inner race does not turn smoothly, quietly, or if the outer race fits loosely in the pressure plate.

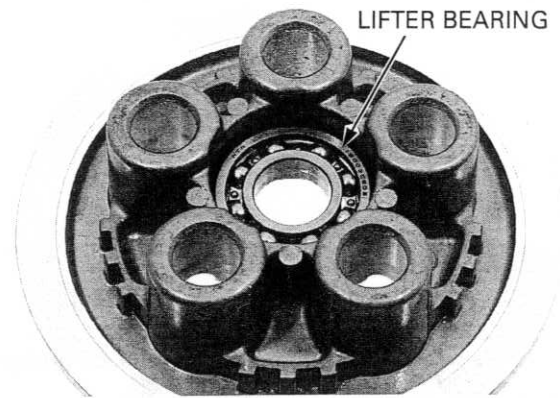

Clutch spring

Replace the clutch springs as a set.

Measure the clutch spring free length.

SERVICE LIMIT: 45.8 mm (1.80 in)

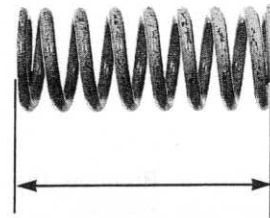

Clutch center

Check the grooves of the clutch center for damage or wear caused by the clutch plates.
Replace it if necessary.

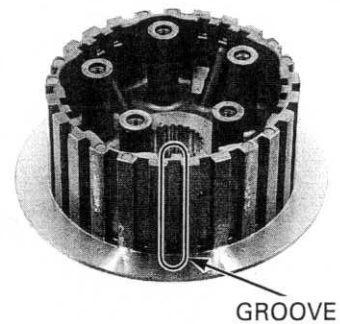

Clutch lifter piece

Check the clutch lifter piece for damage or abnormal wear.

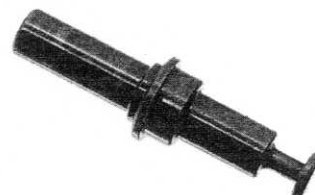

Clutch disc

Replace the clutch discs and plates as a set.

Replace the clutch discs if they show signs of scoring or discoloration.

Measure the disc thickness of each disc.

SERVICE LIMIT: 2.6 mm (0.10 in)

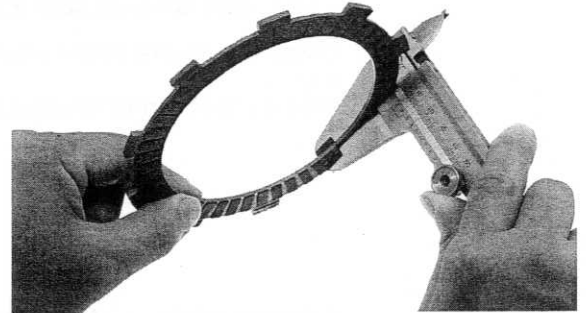

Clutch plate

Replace the clutch discs and plates as a set.

Check the plates for discoloration.

Check the plate warpage on a surface plate using a feeler gauge.

SERVICE LIMIT: 0.30 mm (0.012 in)

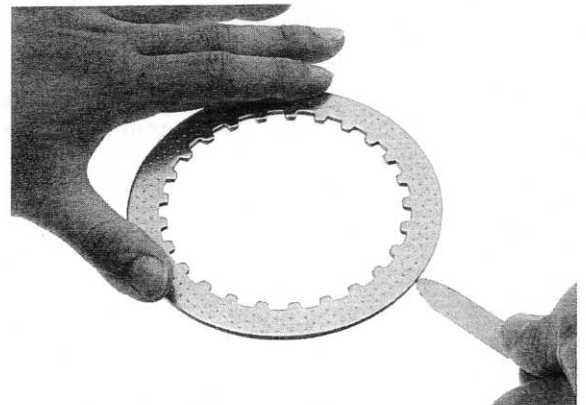

Judder spring/spring seat

Check the judder spring and spring seat for deformation, warpage or damage; replace them if necessary.

- A damaged or warped spring seat will cause the judder spring to be pressed unevenly.
- A damaged judder spring also causes the weak contact between the discs and plates or uneven disc/plate contact.

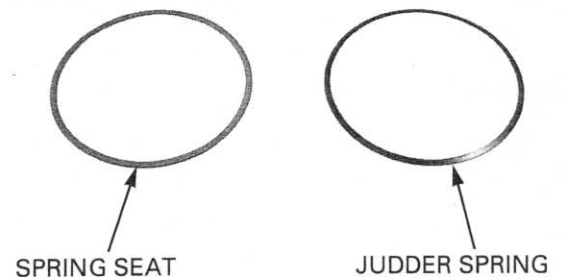

Clutch outer/primary driven gear

Check the slots of the clutch outer for damage or wear caused by the clutch discs.

Check the primary driven gear for abnormal wear or damage.

Measure the I.D. of the primary driven gear.

SERVICE LIMIT: 41.026 mm (1.6152 in)

Replace the clutch outer assembly if necessary.

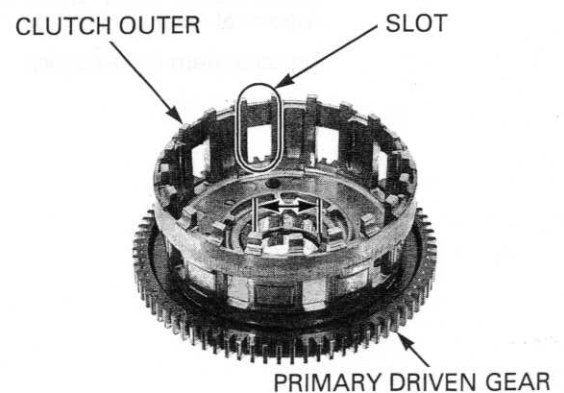

CLUTCH/STARTER CLUTCH/GEARSHIFT LINKAGE

Clutch outer guide/needle bearing

Measure the O.D. and I.D. of the clutch outer guide.

SERVICE LIMITS:

O.D.: 34.986 mm (1.3774 in)

I.D.: 25.013 mm (0.9848 in)

Check the needle bearing turns smoothly and quietly.

Replace the bearing if necessary.

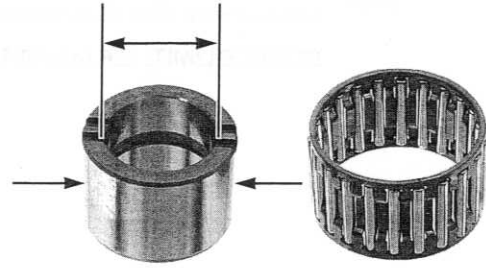

Oil pump drive sprocket guide

Measure the O.D. and I.D. of the oil pump drive sprocket guide.

SERVICE LIMITS:

O.D.: 34.940 mm (1.3756 in)

I.D.: 25.031 mm (0.9855 in)

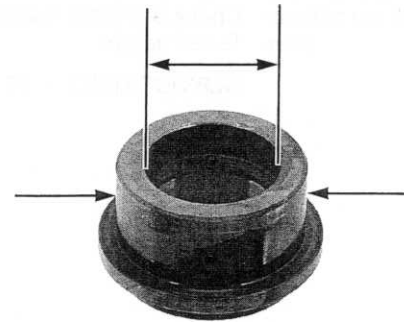

Oil pump drive sprocket

Check the oil pump drive sprocket for abnormal wear or damage.

Measure the I.D. of the oil pump drive sprocket.

SERVICE LIMIT: 35.155 mm (1.3841 in)

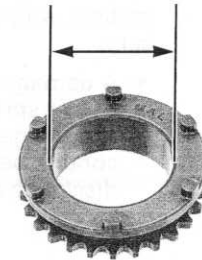

Oil pump drive chain guide A/B

Check the oil pump drive chain guide A and B for abnormal wear or damage.

Replace them if necessary.

CHAIN GUIDE A



CHAIN GUIDE B

CLUTCH/STARTER CLUTCH/GEARSHIFT LINKAGE

Mainshaft

Measure the mainshaft O.D. at clutch outer guide and oil pump drive sprocket guide sliding surfaces.

SERVICE LIMITS: 24.960 mm (0.9827 in)

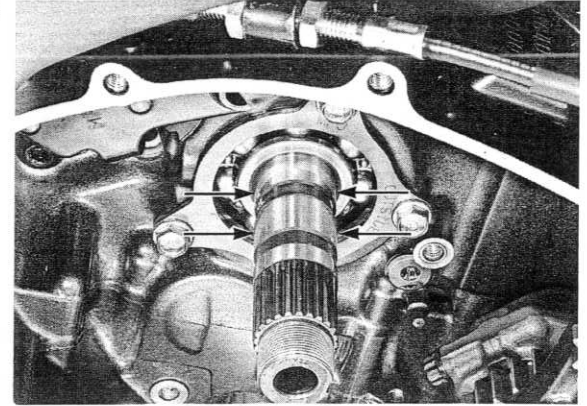

Starter idle gear/idle gear shaft

Check the starter idle gear and shaft for wear or damage, replace them if necessary.

STARTER IDLE GEAR



STARTER IDLE GEAR SHAFT

INSTALLATION

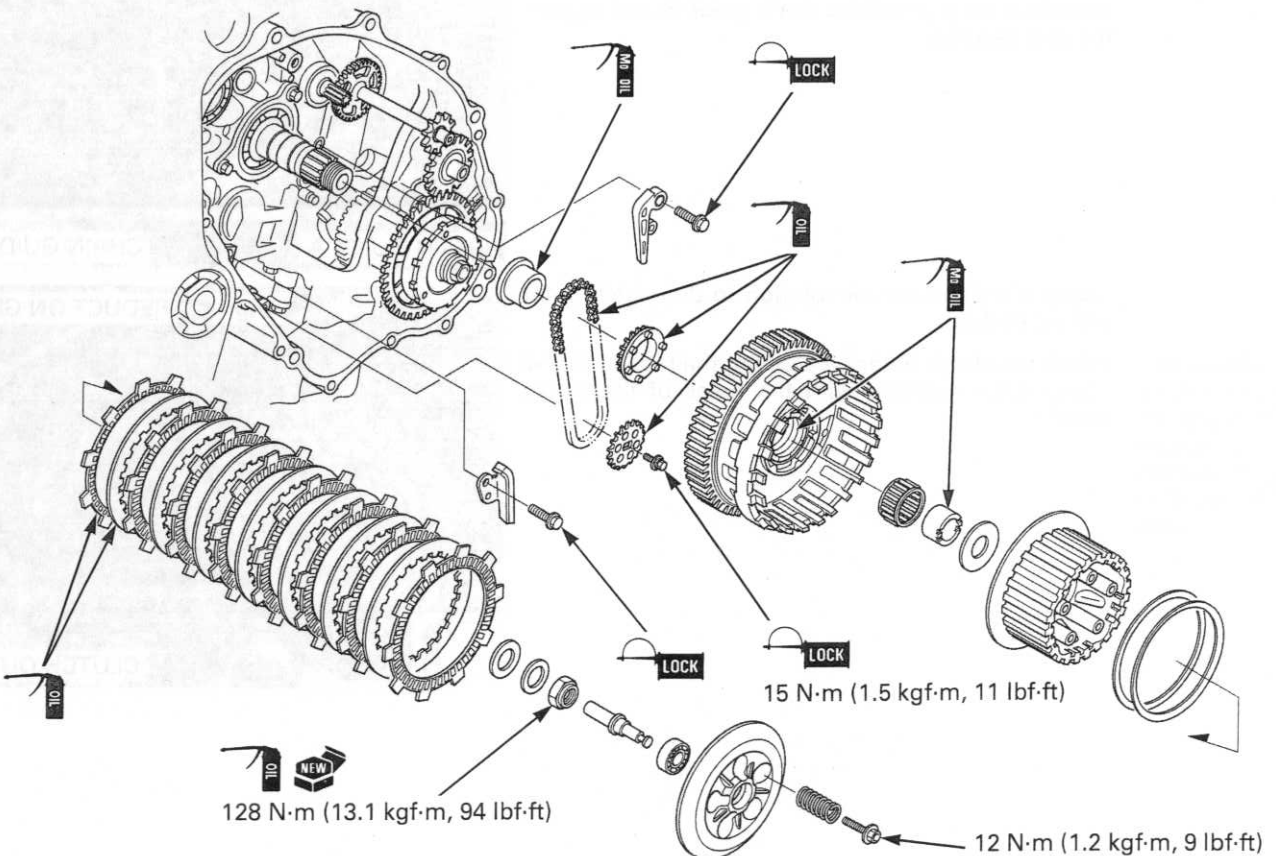

CLUTCH/STARTER CLUTCH/GEARSHIFT LINKAGE

Apply molybdenum oil solution to the oil pump drive sprocket guide sliding surface and install it to the mainshaft.

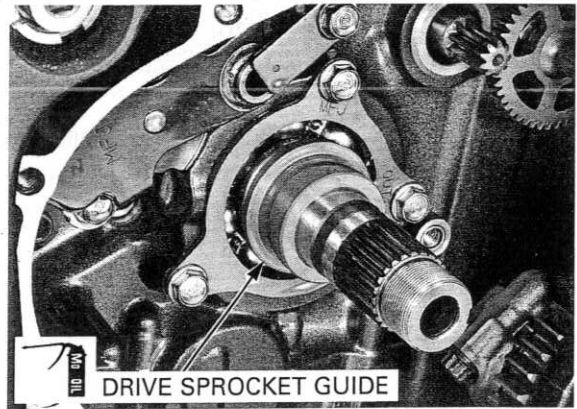

Apply oil to the oil pump drive/driven sprocket teeth and drive chain.

Install the oil pump driven sprocket with its "OUT" mark facing out.

Install the oil pump drive/driven sprocket and drive chain as an assembly.

Apply locking agent to the oil pump driven sprocket bolt threads (page 1-19).

Be careful not to drop the parts into the oil pan.

Install the oil pump driven sprocket bolt, washer and tighten the bolt to the specified torque.

TORQUE: 15 N·m (1.5 kgf·m, 11 lbf·ft)

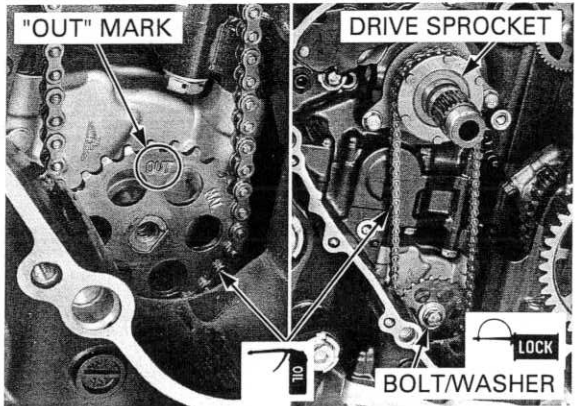

Be careful not to drop the parts into the oil pan.

Apply locking agent to the oil pump drive chain guide mounting bolts threads (page 1-19).

Install the oil pump drive chain guide A and tighten the bolt securely.

Install the oil pump drive chain guide B and tighten the bolt securely.

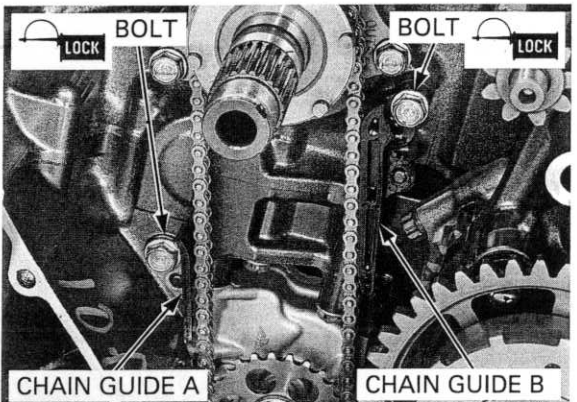

Apply molybdenum oil solution to the clutch outer sliding surface.

Make sure the starter reduction gear is installed into the crankcase (page 10-22) before installing the clutch outer.

Install the clutch outer by aligning the tabs of the oil pump drive sprocket with the holes of the clutch outer.

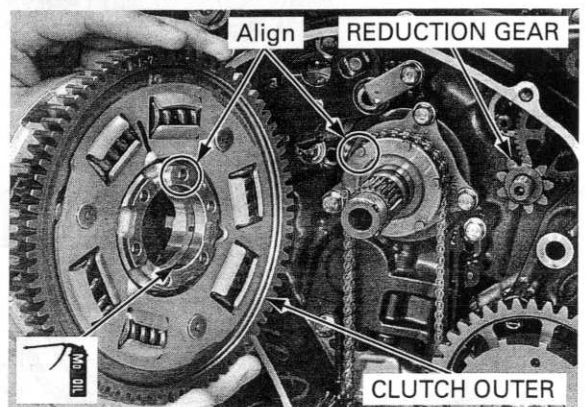

CLUTCH/STARTER CLUTCH/GEARSHIFT LINKAGE

Apply molybdenum oil solution to the clutch outer guide sliding surface.

Install the clutch outer guide with its grooves facing out.

Install the clutch outer guide and needle bearing onto the mainshaft.

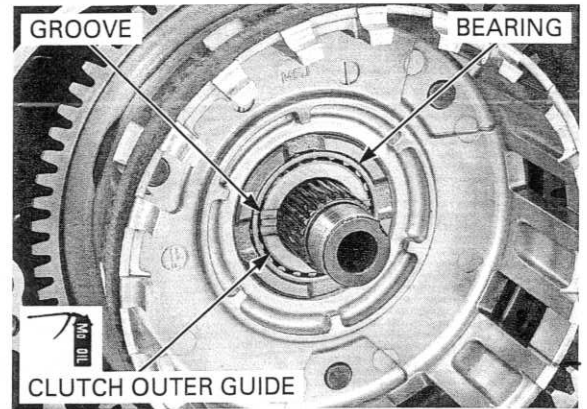

Install the thrust washer.

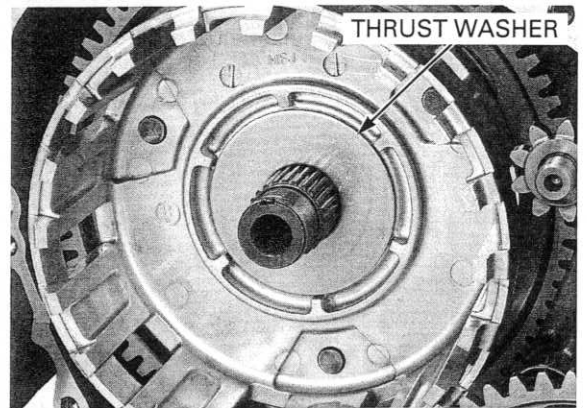

Install the clutch center and thrust washer.

Install the lock washer with its "OUT" mark facing out.

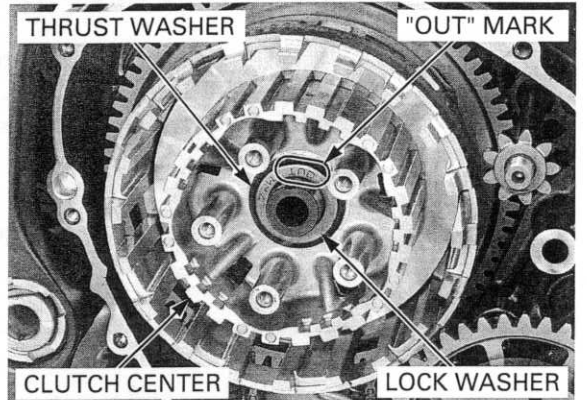

Apply oil to a new clutch center lock nut threads and seating surface then install it onto the mainshaft.

Hold the clutch center with the special tool and tighten the lock nut to the specified torque.

TOOL:

Clutch center holder

07724-0050002 or equivalent commercially available in U.S.A.

TORQUE: 128 N·m (13.1 kgf·m, 94 lbf·ft)

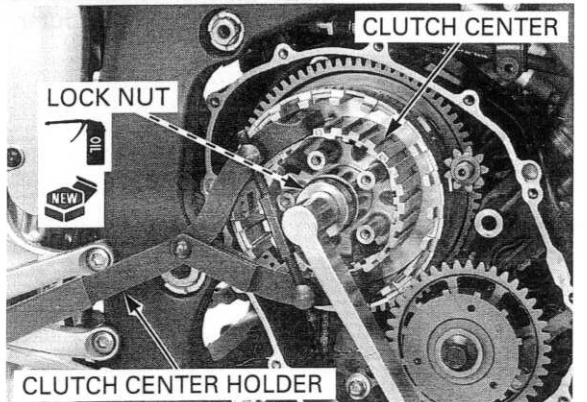

CLUTCH/STARTER CLUTCH/GEARSHIFT LINKAGE

Be careful not to damage the mainshaft threads.

Stake the lock nut into the mainshaft groove with a punch.

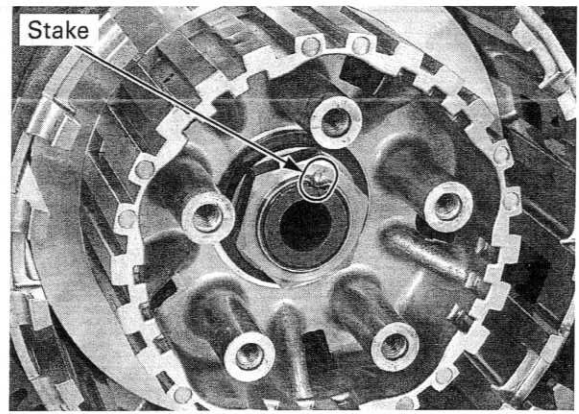

Install the spring seat and judder spring onto the clutch center as shown.

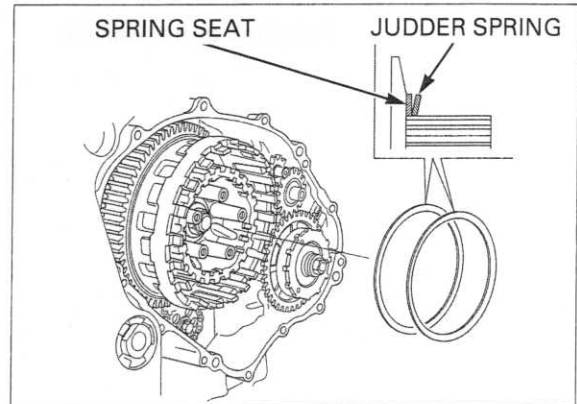

Coat the clutch discs and plates with clean engine oil.

Install the clutch disc B (larger I.D. disc) into the clutch outer.

Stack the seven clutch plates and six discs C alternately.

Install the clutch disc A.

- Clutch disc B has a larger I.D. than the other discs.

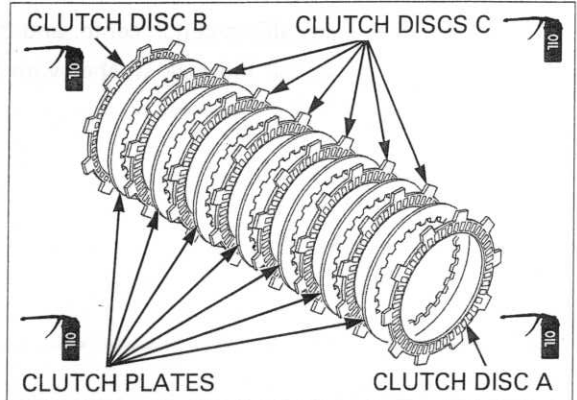

Install the tabs of outside clutch disc A into the shallow slots of the clutch outer.

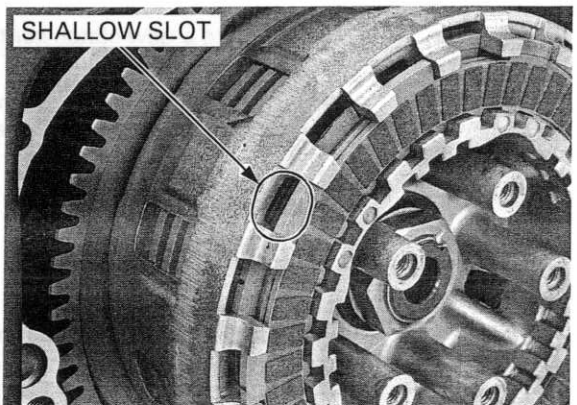

CLUTCH/STARTER CLUTCH/GEARSHIFT LINKAGE

Install the lifter bearing into the pressure plate.
Install the clutch lifter piece into the lifter bearing.

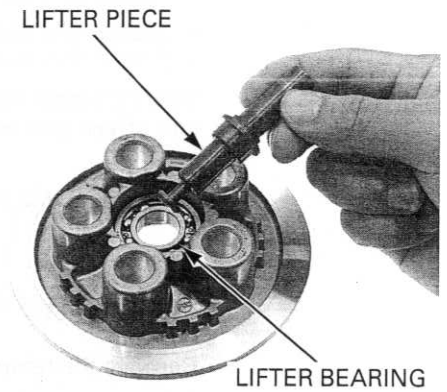

Install the pressure plate.
Install the clutch springs and spring bolts.
Tighten the bolts to the specified torque in a criss-cross pattern in two or three steps.

TORQUE: 12 N·m (1.2 kgf·m, 9 lbf·ft)

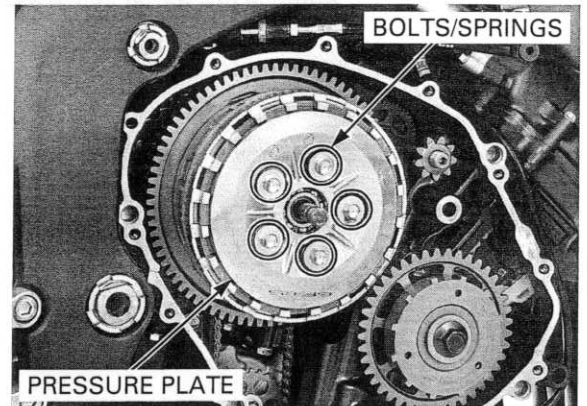

Apply molybdenum oil solution to the starter idle gear shaft sliding surface.

Install the starter idle gear and shaft.

Install the right crankcase cover (page 10-26).

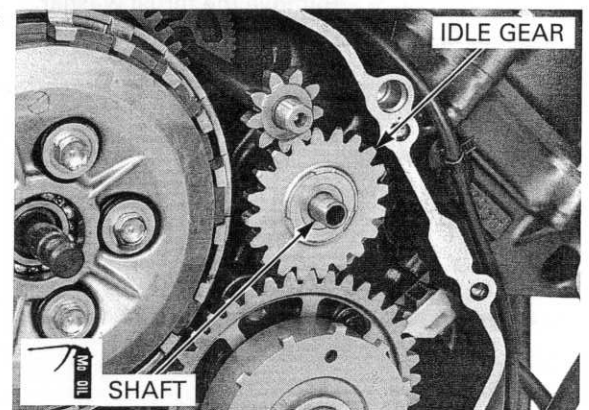

STARTER CLUTCH

REMOVAL

Remove the clutch (page 10-7).

Remove the starter reduction gear from the crankcase.

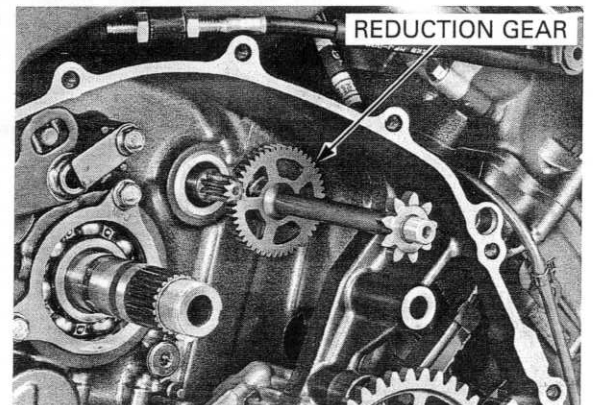

CLUTCH/STARTER CLUTCH/GEARSHIFT LINKAGE

Temporarily install the following:

- Starter idle gear
- Starter idle gear shaft

Insert the gear holder between the starter idle gear and driven gear as shown.

TOOL:

Gear holder, M2.5

07724-0010100 or
07724-001A100
(U.S.A. only)

Remove the starter clutch mounting bolt and washer.

Remove the temporarily installed parts.

Remove the starter clutch assembly.

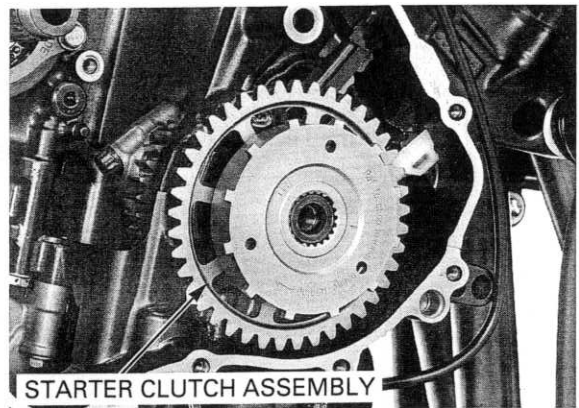
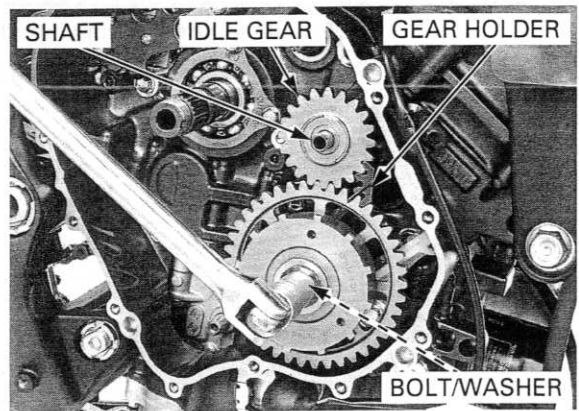

Remove the thrust washer.

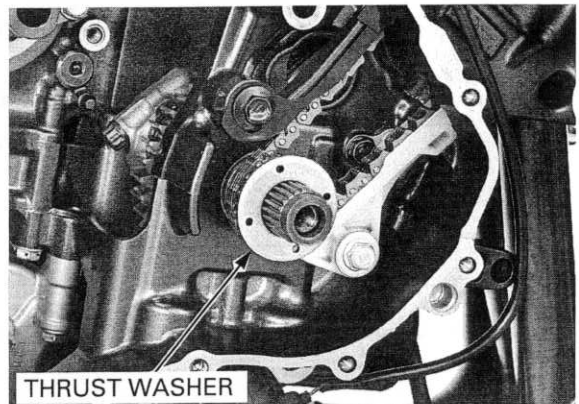

INSPECTION

Check the operation of the one-way clutch by turning the driven gear.

You should be able to turn the driven gear clockwise smoothly, but the gear should not turn counterclockwise.

DISASSEMBLY

Remove the starter driven gear by turning it clockwise.

Remove the needle bearing.

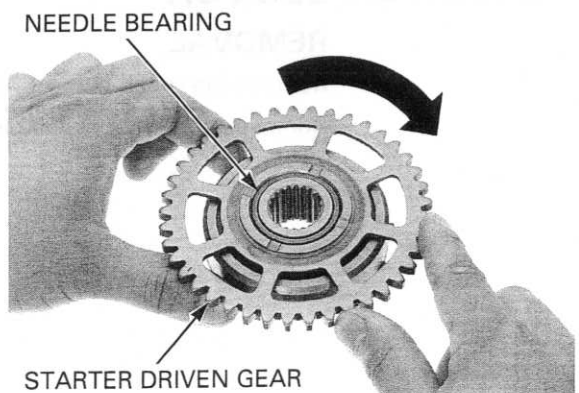

CLUTCH/STARTER CLUTCH/GEARSHIFT LINKAGE

Remove the snap ring and one-way clutch.

SNAP RING

ONE-WAY CLUTCH

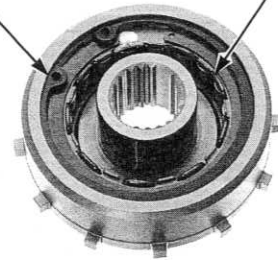

Check the starter clutch outer inner surface and one-way clutch for abnormal wear or damage and replace them if necessary.

ONE-WAY CLUTCH

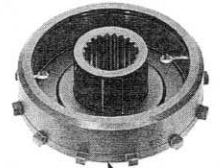

STARTER CLUTCH OUTER

Check the needle bearing for abnormal wear or damage.
Replace it if necessary.



NEEDLE BEARING

Check the starter driven gear for abnormal wear or damage.

Measure the starter driven gear boss O.D.

SERVICE LIMIT: 45.642 mm (1.7969 in)

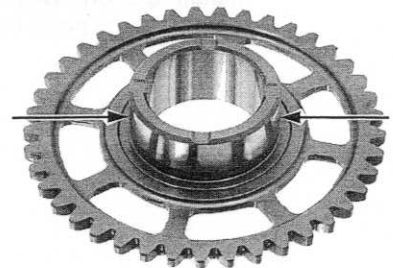

CLUTCH/STARTER CLUTCH/GEARSHIFT LINKAGE

Check the starter reduction gear for wear or damage and replace it if necessary.

REDUCTION GEAR

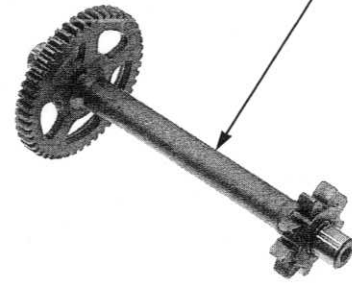

ASSEMBLY

STARTER DRIVEN GEAR

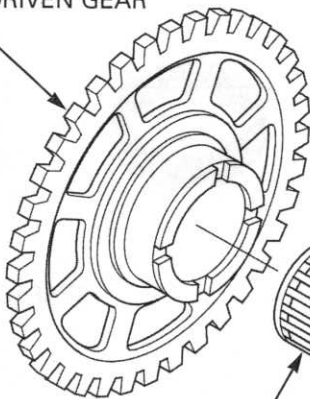

NEEDLE BEARING

SNAP RING

ONE-WAY CLUTCH

STARTER CLUTCH OUTER

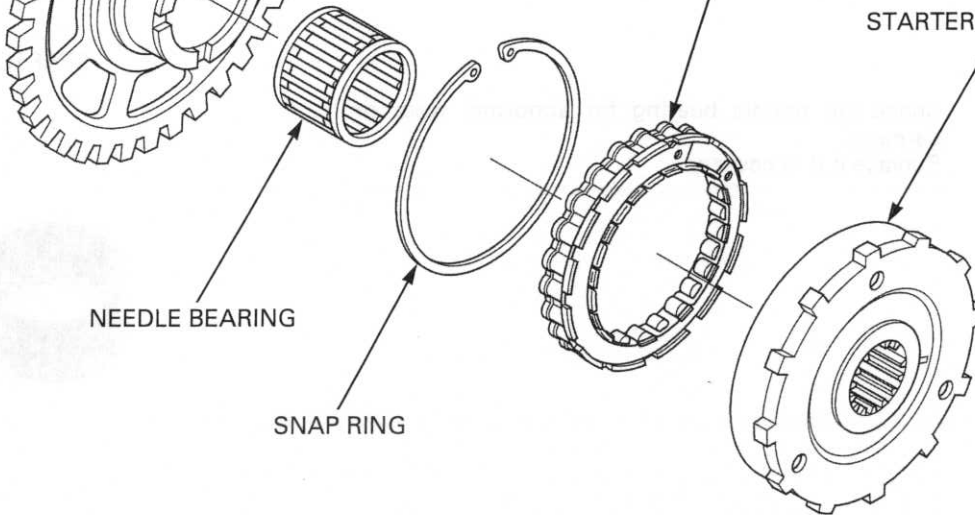

Apply oil to the one-way clutch sliding surface.
Install the one-way clutch into the starter clutch outer with its paint mark facing out.

PAINT MARK

ONE-WAY CLUTCH

STARTER CLUTCH OUTER

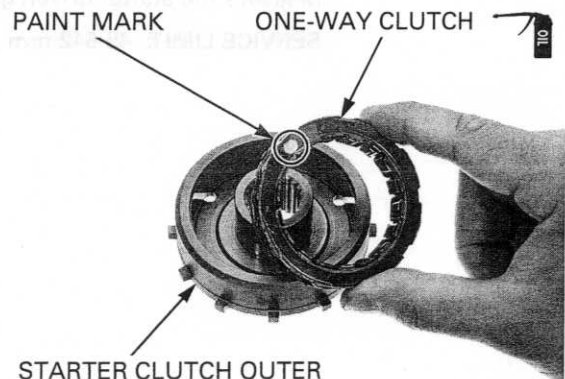

CLUTCH/STARTER CLUTCH/GEARSHIFT LINKAGE

After installing the snap ring, always rotate it in its groove to be sure it is fully seated.

Install the snap ring into the starter clutch outer groove securely.

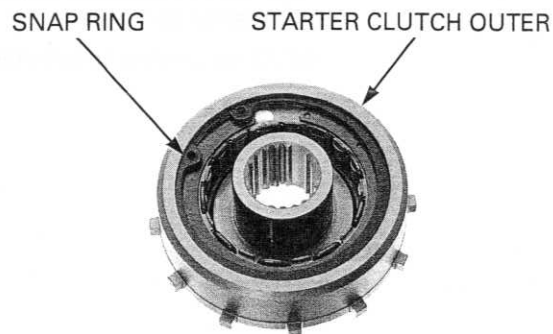

Install the starter driven gear and needle bearing into the starter clutch outer while turning the starter driven gear clockwise.

Recheck the one-way clutch operation (page 10-18).

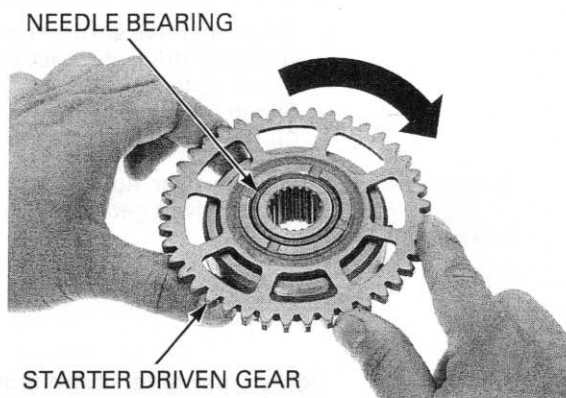

INSTALLATION

Install the thrust washer to the crankshaft.

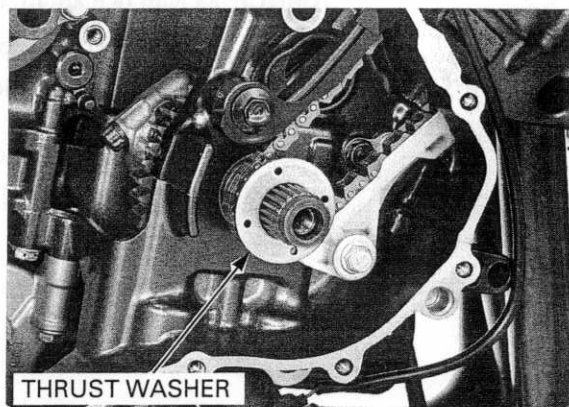

Install the starter clutch assembly to the crankshaft while aligning the wide teeth of the crankshaft with the starter clutch assembly.

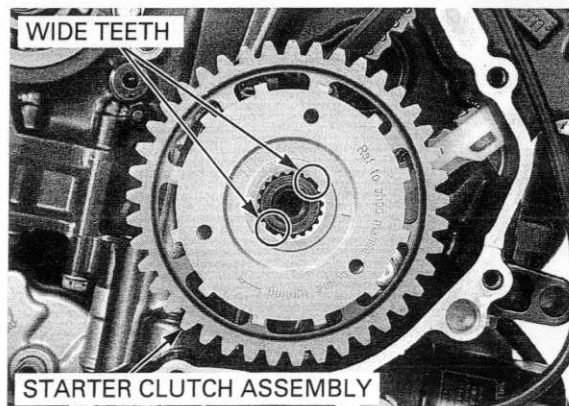

CLUTCH/STARTER CLUTCH/GEARSHIFT LINKAGE

Apply oil to the starter clutch mounting bolt threads and seating surface.

Install the washer and starter clutch mounting bolt.

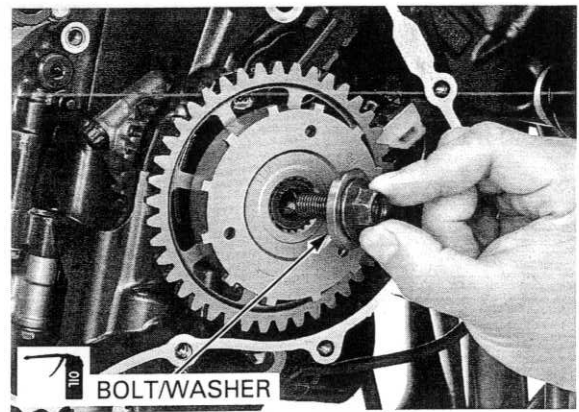

Temporarily install the following:

- Oil pump drive sprocket guide
- Oil pump drive sprocket gear
- Clutch outer
- Clutch outer guide
- Clutch outer needle bearing

Be careful not to drop the gear holder into the oil pan.

Attach the gear holder between the primary drive gear and driven gear.

TOOL:

Gear holder, M2.5

07724-0010100 or
07724-001A100
(U.S.A. only)

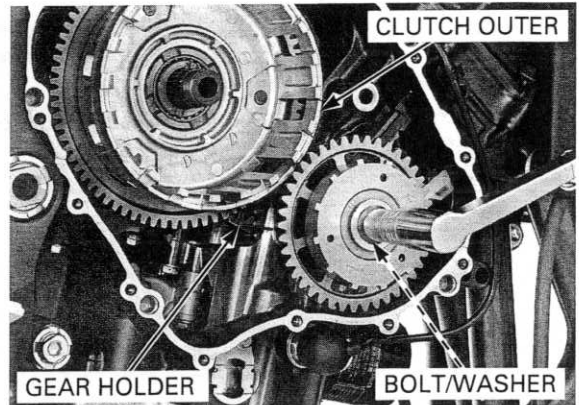

Tighten the starter clutch mounting bolt to the specified torque.

TORQUE: 83 N·m (8.5 kgf·m, 61 lbf·ft)

Remove the temporarily installed parts.

Apply molybdenum oil solution to the starter reduction gear sliding surface.

Install the starter reduction gear into the crankcase.

Install the clutch (page 10-13).

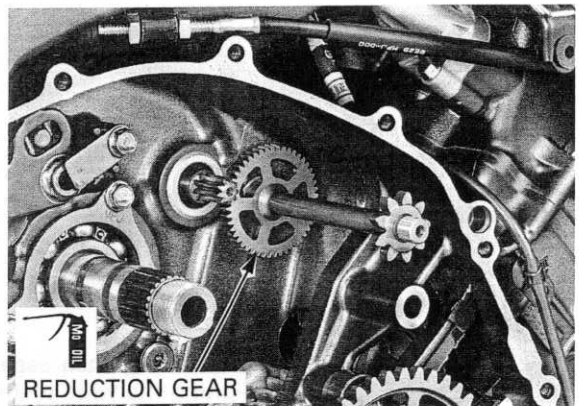

GEARSHIFT LINKAGE

REMOVAL

Remove the following:

- Right crankcase cover (page 10-5)
- Clutch (page 10-7)

Remove the bolt and disconnect the gearshift arm from the gearshift spindle.

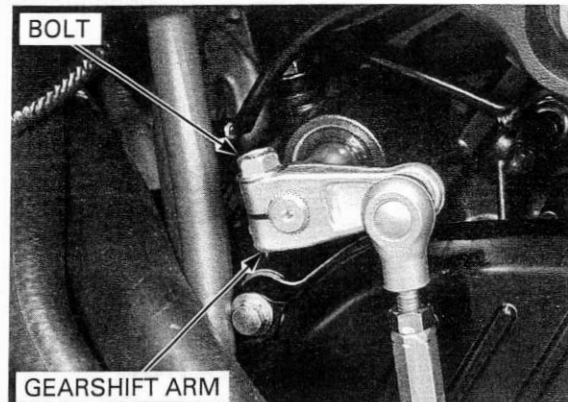

Remove the bolt and setting plate.

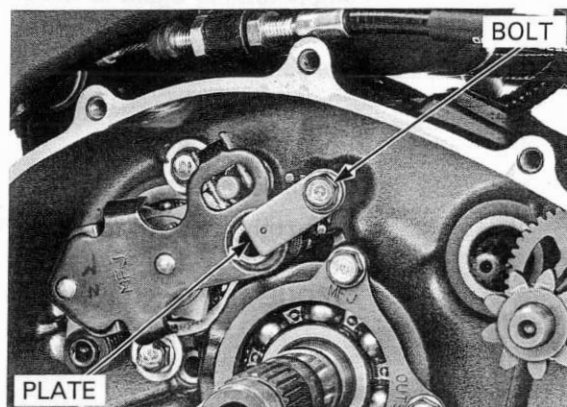

Pull the gearshift spindle and thrust washer out of the crankcase.

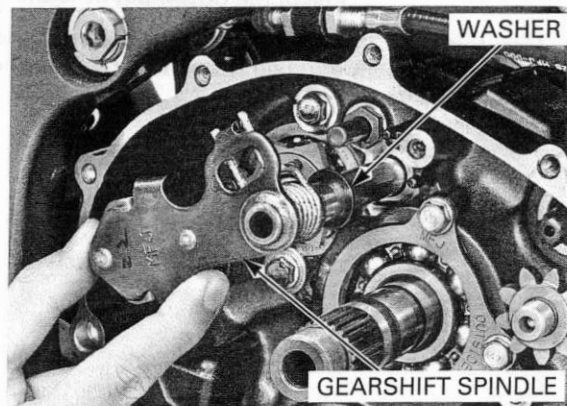

Be careful not to drop the parts into the oil pan.

Remove the following:

- Stopper arm pivot bolt
- Stopper arm
- Return spring
- Washer
- Shift drum center bolt
- Gearshift cam
- Dowel pin

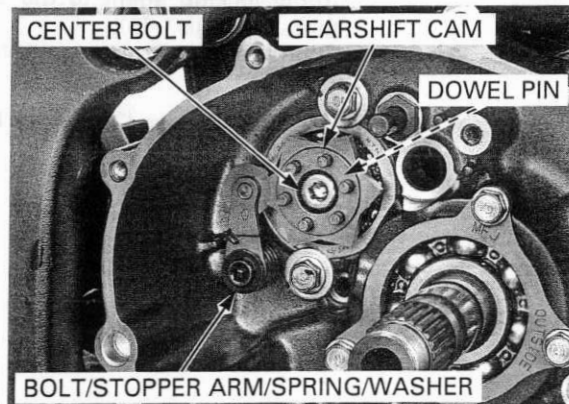

CLUTCH/STARTER CLUTCH/GEARSHIFT LINKAGE

INSPECTION

Check the gearshift spindle for wear, damage or bending.
Check the return spring for fatigue or damage.

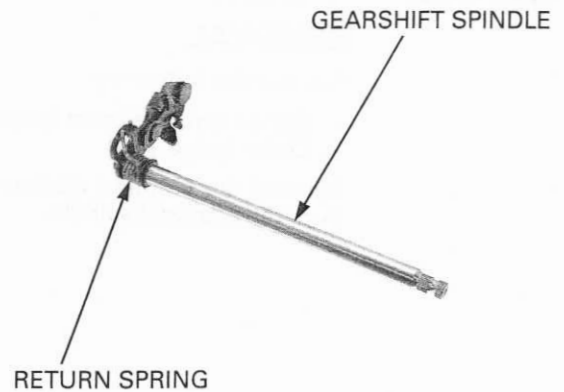

INSTALLATION

Apply locking agent to the shift drum stopper arm pivot bolt threads (page 1-19).

Install the following:

- Washer
- Return spring
- Stopper arm
- Stopper arm pivot bolt

Tighten the stopper arm pivot bolt to the specified torque.

TORQUE: 12 N·m (1.2 kgf·m, 9 lbf·ft)

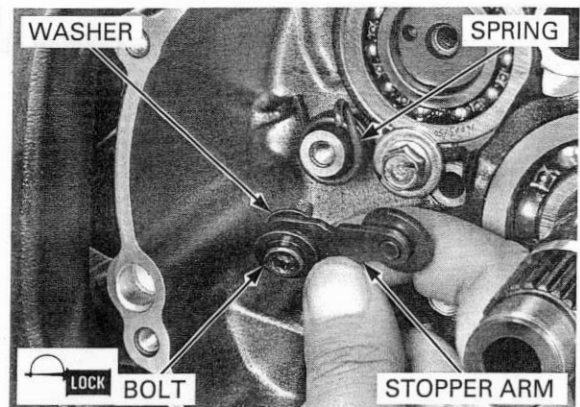

Install the dowel pin onto the shift drum.

Install the gearshift cam while holding the stopper arm using a screwdriver as shown.

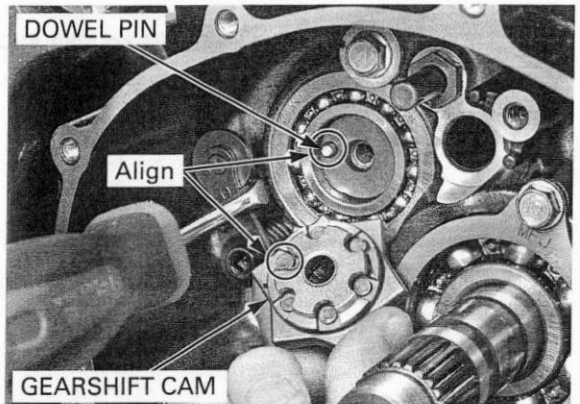

Apply locking agent to the shift drum center bolt threads (page 1-19).

Tighten the shift drum center bolt to the specified torque.

TORQUE: 23 N·m (2.3 kgf·m, 17 lbf·ft)

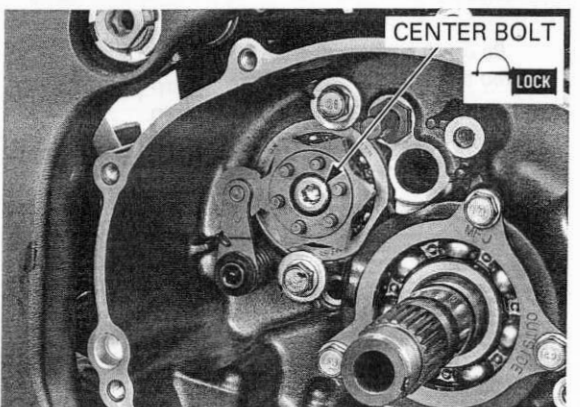

Be careful not to drop the parts into the oil pan.

Align the dowel pin on the shift drum with the wide groove on the gearshift cam.

CLUTCH/STARTER CLUTCH/GEARSHIFT LINKAGE

Install the thrust washer and gearshift spindle into the crankcase while aligning the spring ends with the stopper pin.

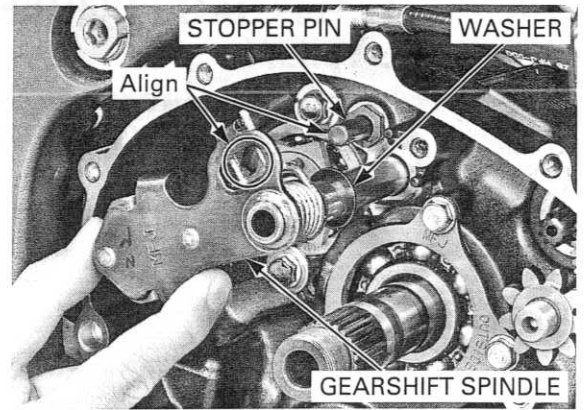

Apply locking agent to the setting plate bolt threads (page 1-19).
Install the setting plate and tighten the bolt securely.

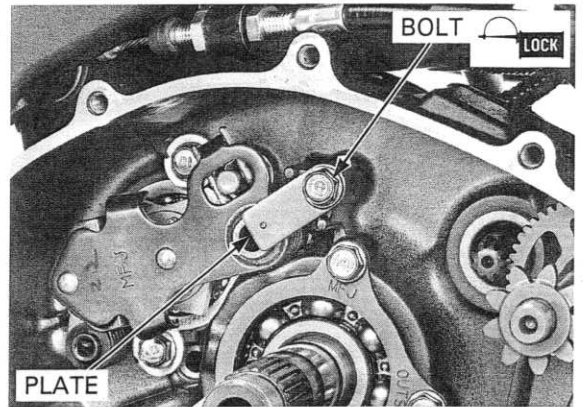

Install the gearshift arm to the gearshift spindle, aligning the arm slit with the punch mark on the gearshift spindle.
Install and tighten the pinch bolt.

Install the following:

- Clutch (page 10-13)
- Right crankcase cover (page 10-26)

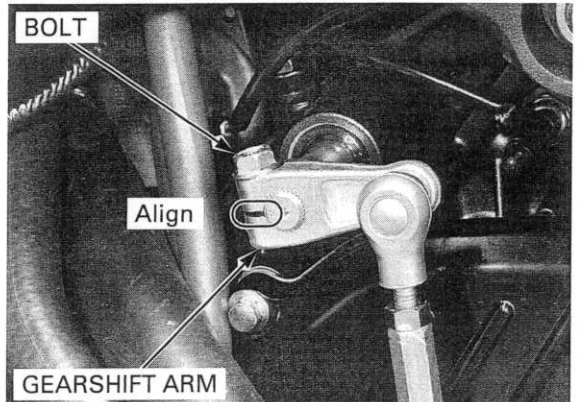

RIGHT CRANKCASE COVER INSTALLATION

Apply sealant (TB 1207 B or equivalent) to the mating surface of the right crankcase cover as shown.

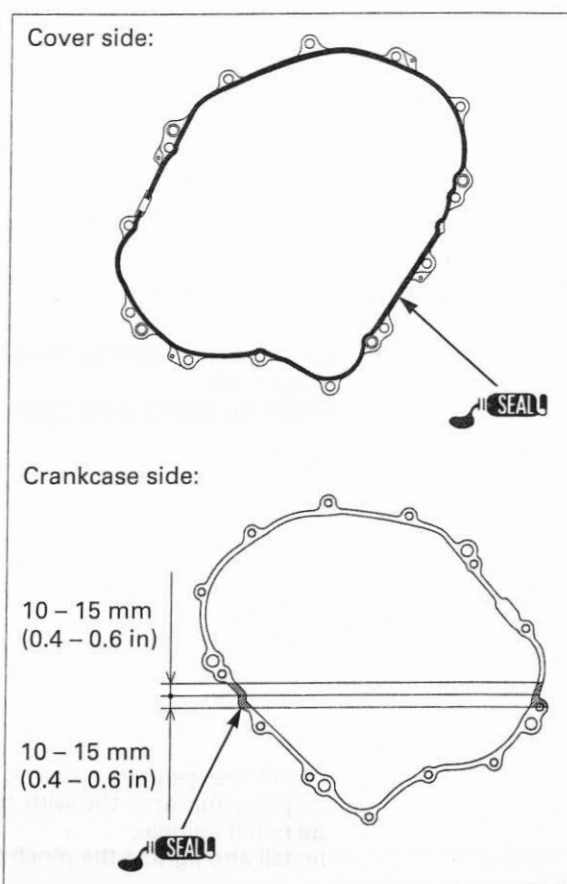

Install the four dowel pins.

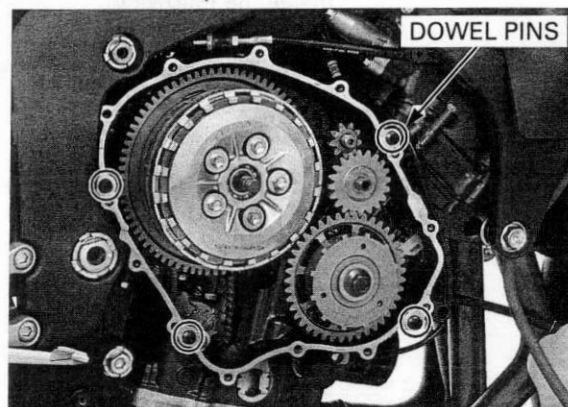

Install the wave washer and thrust washer onto the starter idle gear.

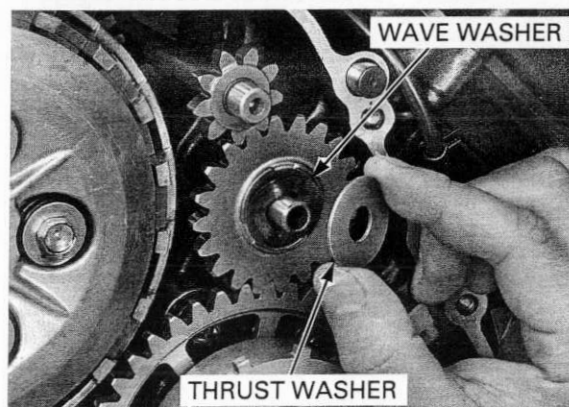

CLUTCH/STARTER CLUTCH/GEARSHIFT LINKAGE

Install the right crankcase cover while turning the lifter lever clockwise to engage the lifter lever spindle groove with the lifter piece flange.

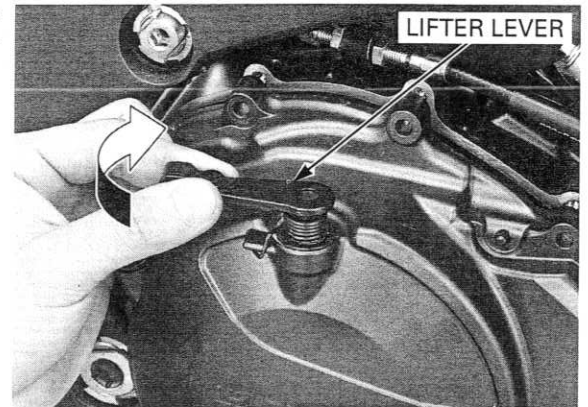

Route the EOP switch wire properly (page 1-21).

Install the stays and right crankcase cover bolts.

Tighten the right crankcase cover bolts crisscross pattern in two or three steps.

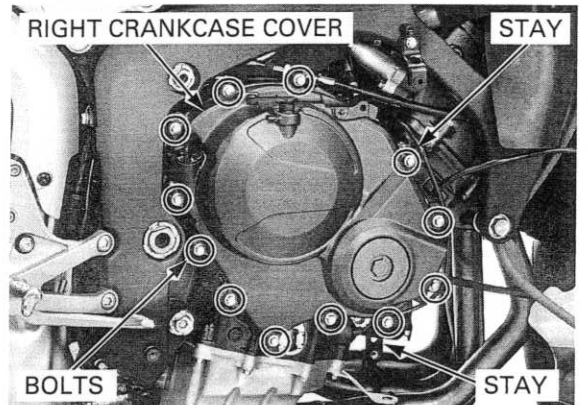

Route the clutch cable properly (page 1-21).

Connect the clutch cable to the clutch lifter lever.

Install the clutch cable guide plate by aligning its hole with the right crankcase cover boss and tighten the bolt securely.

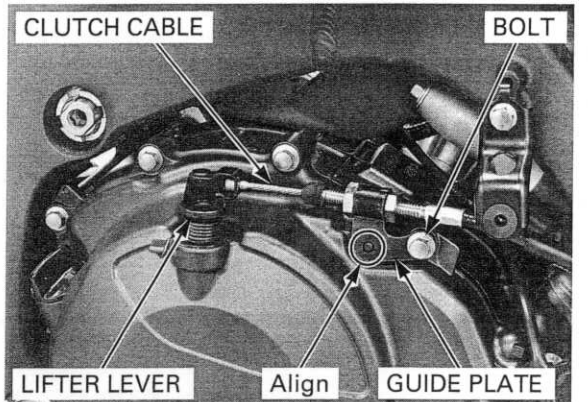

Route the CKP sensor wire properly (page 1-21).

Connect the CKP sensor 2P (Black) connector.

Add the recommended engine oil (page 4-17) and check that there are no oil leaks.

Remove the suitable support and close the fuel tank (page 4-6).

Install the removed parts in the reverse order of removal.

Adjust the clutch lever freeplay (page 4-31).

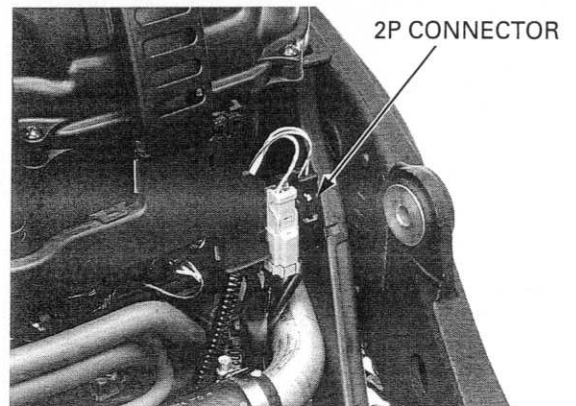

MEMO

MEMORANDUM FOR THE RECORD

MEMORANDUM FOR THE RECORD

MEMORANDUM FOR THE RECORD

11. ALTERNATOR

COMPONENT LOCATION	11-2	STATOR	11-4
SERVICE INFORMATION	11-3	FLYWHEEL	11-5
ALTERNATOR COVER REMOVAL	11-4	ALTERNATOR COVER INSTALLATION	11-6

ALTERNATOR

COMPONENT LOCATION

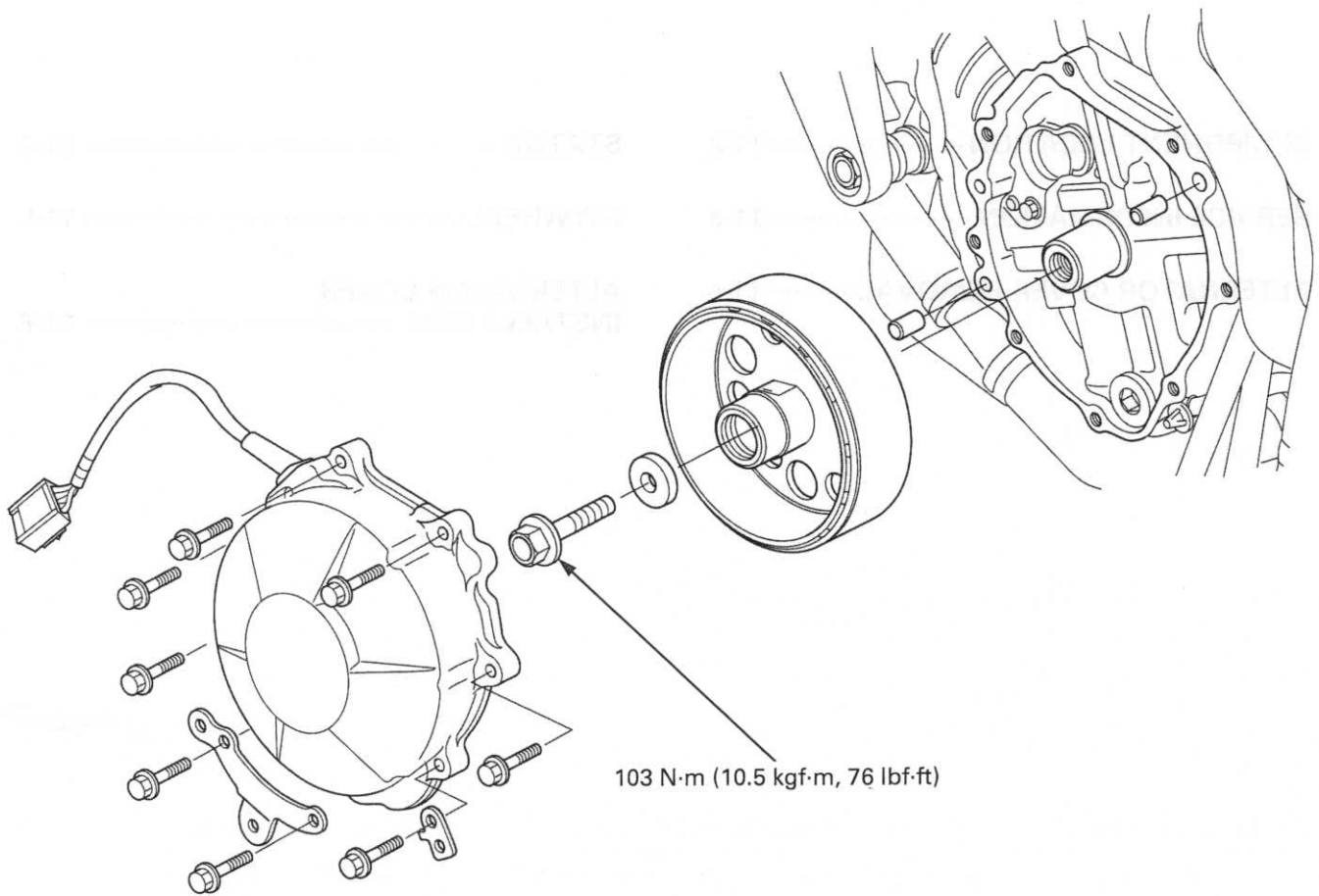

SERVICE INFORMATION

GENERAL

- This section covers service of the stator and flywheel. All service can be done with the engine installed in the frame.
- Refer to procedures for stator inspection (page 17-8).

TORQUE VALUES

Stator mounting bolt	12 N·m (1.2 kgf·m, 9 lbf·ft)	Apply oil to the threads and seating surface CT bolt
Flywheel bolt	103 N·m (10.5 kgf·m, 76 lbf·ft)	
Stator wire clamp bolt	12 N·m (1.2 kgf·m, 9 lbf·ft)	

TOOLS

<p>Flywheel holder 070MB-MELC100</p> 	<p>Flywheel holder 07AMB-MELA100 (U.S.A. only)</p> 	<p>Rotor puller 07733-0020001</p>  <p>or 07933-3950000 (U.S.A. only)</p>
--	---	---

ALTERNATOR

ALTERNATOR COVER REMOVAL

Remove the following:

- Lower cowl (page 3-6)
- Left middle cowl (page 3-8)

Disconnect the alternator 3P (Natural) connector.

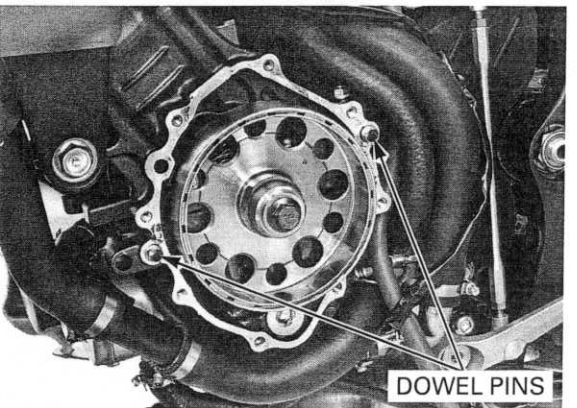
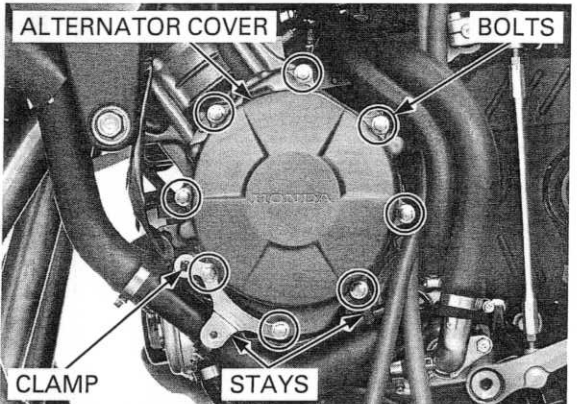
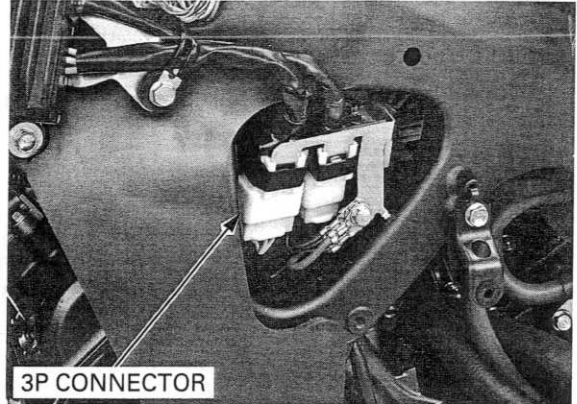

The alternator cover (stator) is magnetically attracted to the flywheel, be careful during removal.

Remove the alternator wire clamp, bolts, stays and alternator cover.

- Engine oil will run out when the alternator cover is removed. Set a oil pan under the engine and add the recommended oil to the specified level after installation.

Remove the dowel pins.

Clean off any sealant from the alternator cover mating surfaces.

STATOR

REMOVAL

Remove the bolt, wire clamp and grommet from the alternator cover.

Remove the bolts and stator.

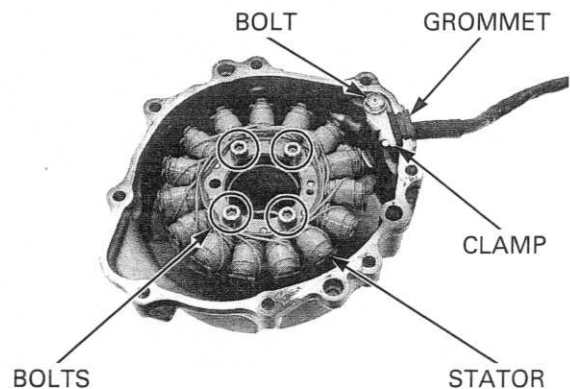

INSTALLATION

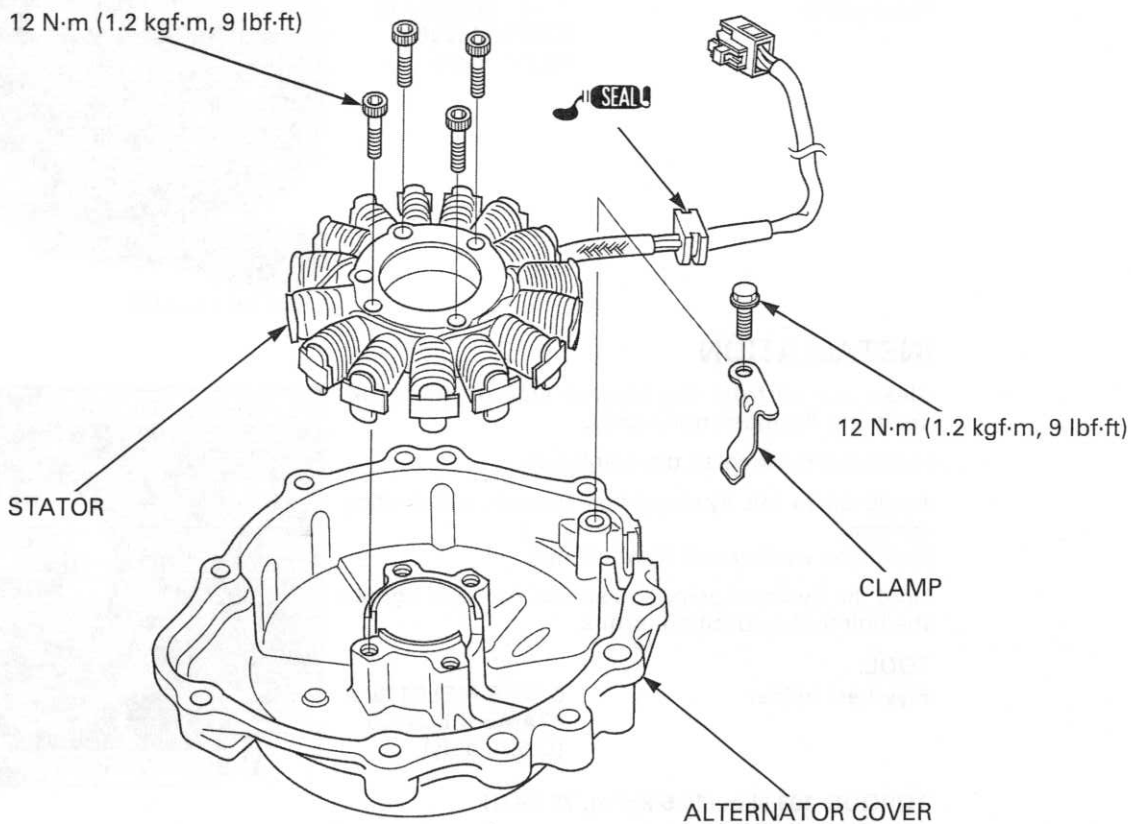

Install the stator to the alternator cover.
Tighten the bolts to the specified torque.

TORQUE: 12 N·m (1.2 kgf·m, 9 lbf·ft)

Apply sealant to the wire grommet, then install it into the alternator cover groove securely.

Install the wire clamp and tighten the bolt to the specified torque.

TORQUE: 12 N·m (1.2 kgf·m, 9 lbf·ft)

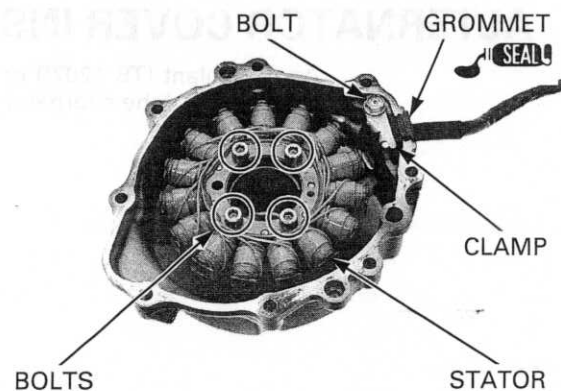

FLYWHEEL

REMOVAL

Remove the alternator cover (page 11-4).

Hold the flywheel using the special tool and remove the flywheel bolt.

TOOL:

Flywheel holder

**070MB-MELC100 or
07AMB-MELA100
(U.S.A. only)**

Remove the washer.

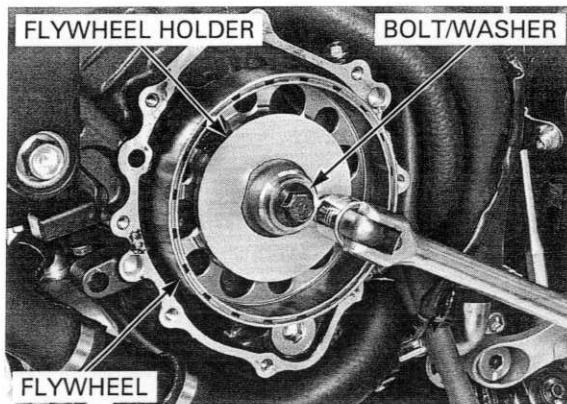

ALTERNATOR

Remove the flywheel using the special tool.

TOOL:

Rotor puller

07733-0020001 or
07933-3950000
(U.S.A. only)

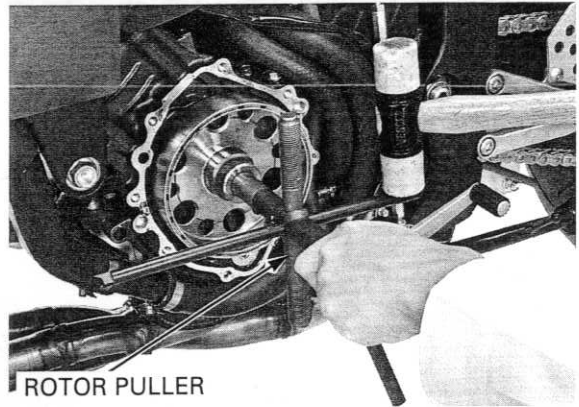

ROTOR PULLER

INSTALLATION

Clean any oil from the tapered area of the crankshaft and flywheel thoroughly.

Install the flywheel to the crankshaft.

Apply oil to the flywheel bolt threads and seating surface.

Install the washer and flywheel bolt.

Hold the flywheel using the special tool and tighten the bolt to the specified torque.

TOOL:

Flywheel holder

070MB-MELC100 or
07AMB-MELA100
(U.S.A. only)

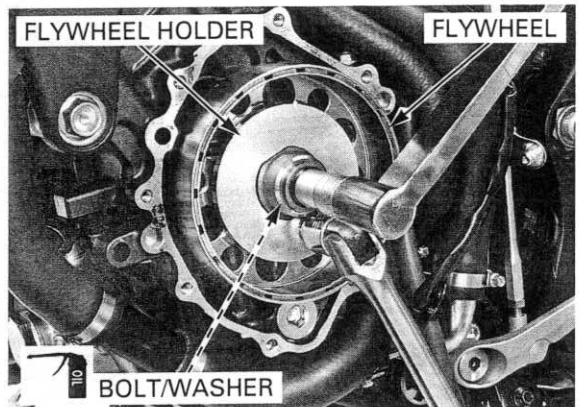

TORQUE: 103 N·m (10.5 kgf·m, 76 lbf·ft)

ALTERNATOR COVER INSTALLATION

Apply sealant (TB 1207B or equivalent) to the mating surface of the alternator cover.

Cover side:

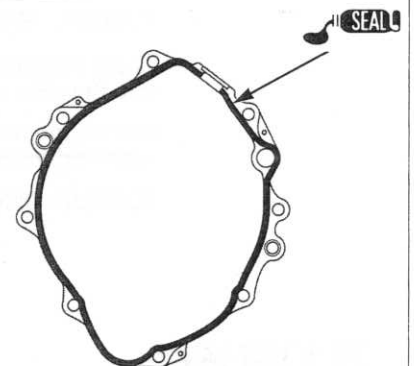

Crankcase side:

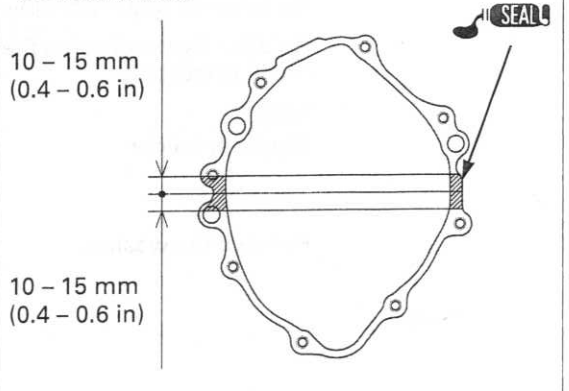

Install the dowel pins.

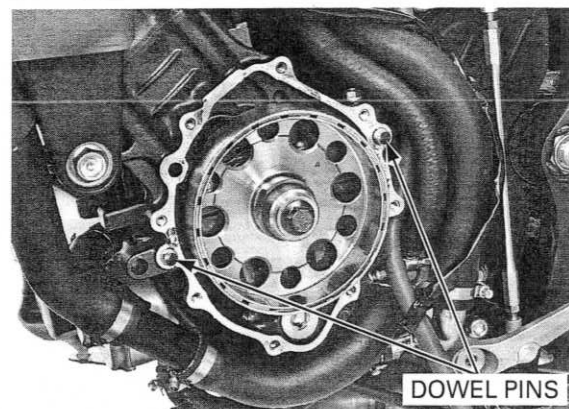

The alternator cover (stator) is magnetically attracted to the flywheel, be careful during installation.

Install the alternator cover, stays and bolts.

Tighten the bolts in a crisscross pattern in two or three steps securely.

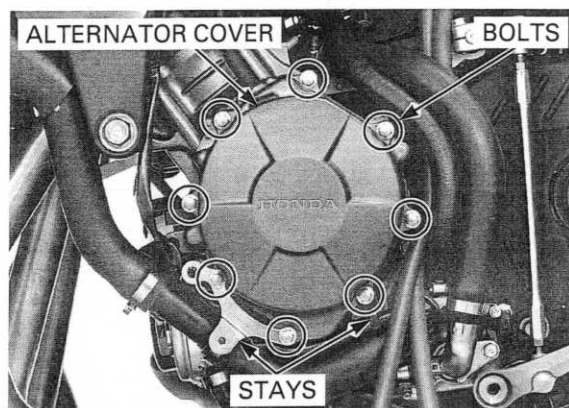

Connect the alternator 3P (Natural) connector.

After installation, add the recommended engine oil to the specified level.

Check the engine oil level (page 4-17).

Install the following:

- Left middle cowl (page 3-8)
- Lower cowl (page 3-6)

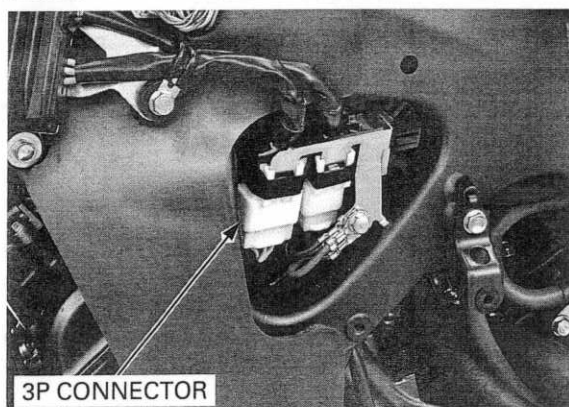

MEMO

[Faint, illegible text in the left margin]

[Faint, illegible text in the left margin]

[Faint, illegible text in the main body]

[Faint, illegible text in the main body]

12. CRANKCASE/TRANSMISSION

COMPONENT LOCATION	12-2	CRANKCASE SEPARATION	12-5
SERVICE INFORMATION	12-3	SHIFT FORK/SHIFT DRUM/ TRANSMISSION.....	12-6
TROUBLESHOOTING	12-4	CRANKCASE ASSEMBLY	12-16

CRANKCASE/TRANSMISSION

COMPONENT LOCATION

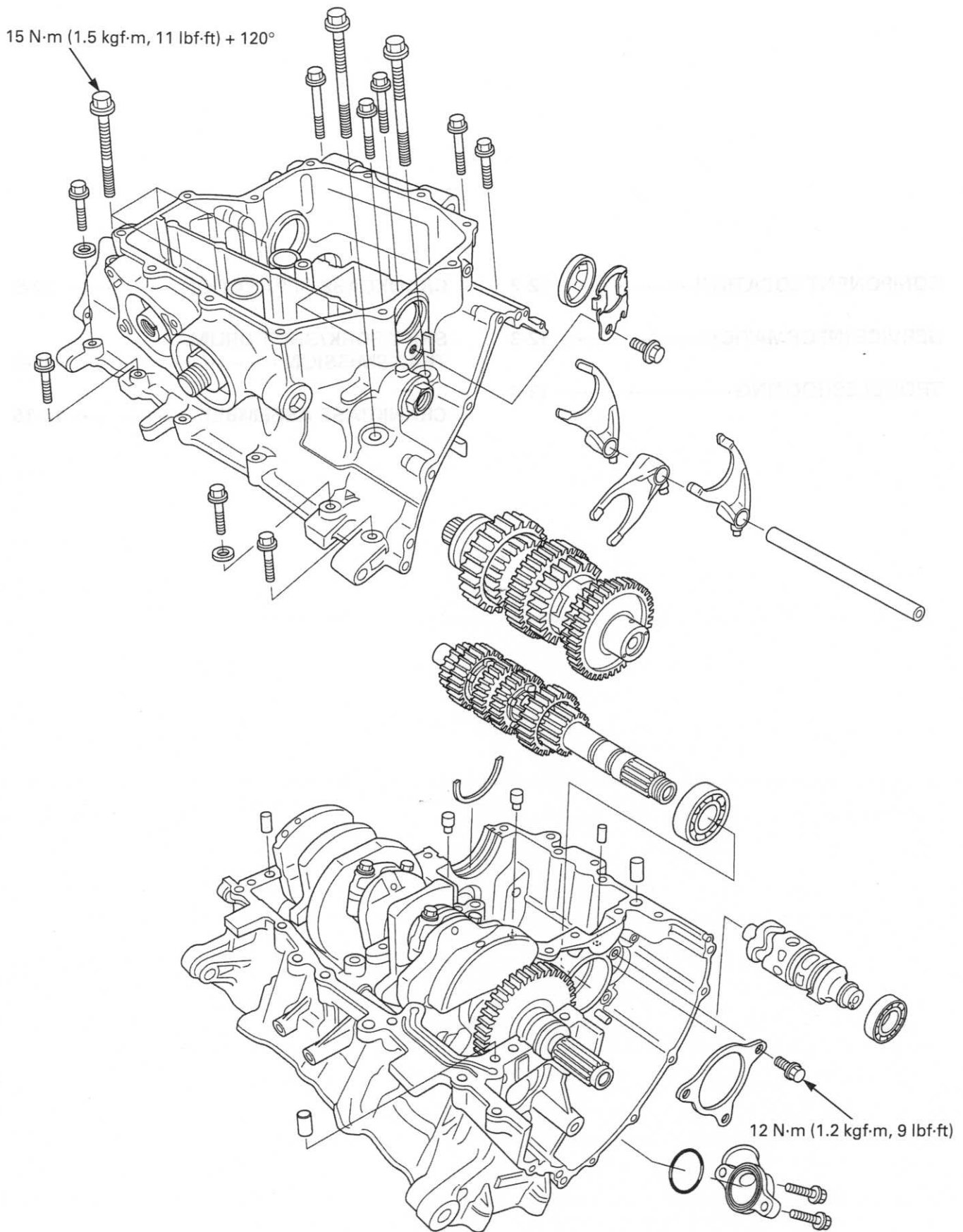

SERVICE INFORMATION

GENERAL

- The crankcase must be separated to service the following:
 - Transmission
 - Crankshaft (page 13-5)
 - Piston/cylinder (page 13-14)
- The following components must be removed before separating the crankcase:
 - Engine (page 8-4)
 - Clutch (page 10-7)/gearshift linkage (page 10-23)
 - Starter clutch (page 10-17)
 - Flywheel (page 11-5)
 - Cylinder head (page 9-14)
 - Oil strainer/pressure relief valve (page 5-5), oil pump (page 5-7), oil filter (page 4-17) and oil cooler (page 5-13)
 - Starter motor (page 19-6)
 - Water pump (page 7-17)
 - EOP switch (page 20-15)
 - VS sensor (page 20-11)
 - Neutral switch (page 20-20)
- Be careful not to damage the crankcase mating surfaces when servicing.
- Prior to assembling the crankcase halves, apply sealant to their mating surfaces. Wipe off excess sealant thoroughly.

SPECIFICATIONS

Unit: mm (in)



ITEM		STANDARD	SERVICE LIMIT
Shift fork	I.D.	12.000 – 12.018 (0.4724 – 0.4731)	12.03 (0.474)
	Claw thickness	5.93 – 6.00 (0.233 – 0.236)	5.9 (0.23)
Shift fork shaft O.D.		11.957 – 11.968 (0.4707 – 0.4712)	11.95 (0.470)
Transmission	Gear I.D.	M5, M6	28.000 – 28.021 (1.1024 – 1.1032)
		C1	24.000 – 24.021 (0.9449 – 0.9457)
		C2, C3, C4	31.000 – 31.025 (1.2205 – 1.2215)
	Gear busing O.D.	M5, M6	27.959 – 27.980 (1.1007 – 1.1016)
		C2	30.955 – 30.980 (1.2187 – 1.2197)
		C3, C4	30.950 – 30.975 (1.2185 – 1.2195)
	Gear-to-bushing clearance	M5, M6	0.020 – 0.062 (0.0008 – 0.0024)
		C2	0.020 – 0.070 (0.0008 – 0.0028)
		C3, C4	0.025 – 0.075 (0.0010 – 0.0030)
	Gear bushing I.D.	M5	24.985 – 25.006 (0.9837 – 0.9845)
		C2	27.985 – 28.006 (1.1018 – 1.1026)
	Mainshaft O.D.	at M5	24.967 – 24.980 (0.9830 – 0.9835)
	Countershaft O.D.	at C2	27.967 – 27.980 (1.1011 – 1.1016)
	Bushing to shaft clearance	M5	0.005 – 0.039 (0.0002 – 0.0015)
C2		0.005 – 0.039 (0.0002 – 0.0015)	

TORQUE VALUES

Mainshaft bearing set plate bolt	12 N·m (1.2 kgf·m, 9 lbf·ft)	Apply locking agent to the threads
Shift drum bearing set bolt	12 N·m (1.2 kgf·m, 9 lbf·ft)	Apply locking agent to the threads
Crankcase	6 mm bolt	12 N·m (1.2 kgf·m, 9 lbf·ft)
	8 mm bolt	24 N·m (2.4 kgf·m, 18 lbf·ft)
	8 mm bolt (main journal bolt)	15 N·m (1.5 kgf·m, 11 lbf·ft) + 120°
	10 mm bolt	39 N·m (4.0 kgf·m, 29 lbf·ft)
		See page 12-17 Replace with a new one

CRANKCASE/TRANSMISSION

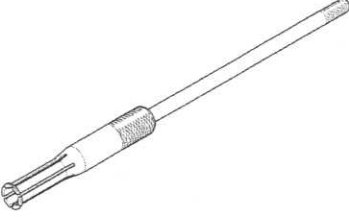
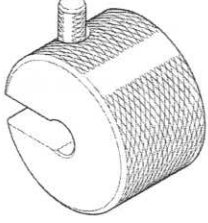
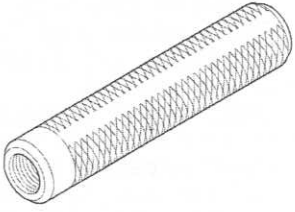
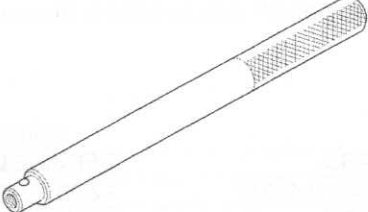
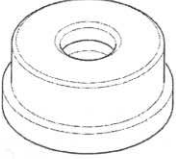
TOOLS

<p>Bearing remover set, 20 mm 07936-3710600</p> 	<p>Remover weight 07741-0010201</p>  <p>or 07936-371020A (U.S.A. only)</p>	<p>Remover handle 07936-3710100</p> 
<p>Driver 07949-3710001</p> 	<p>Attachment, 42 x 47 mm 07746-0010300</p> 	<p>Pilot, 20 mm 07746-0040500</p> 

TROUBLESHOOTING

Hard to shift

- Improper clutch operation
- Incorrect engine oil weight
- Bent shift fork
- Bent shift fork shaft
- Bent shift fork claw
- Damaged shift drum groove
- Bent gearshift spindle (page 10-24)

Transmission jumps out of gear

- Worn gear dogs
- Worn gear shifter groove
- Bent shift fork shaft
- Broken shift drum stopper arm
- Broken shift drum stopper arm spring
- Worn or bent shift forks
- Broken gearshift spindle return spring (page 10-24)

Excessive engine noise

- Worn or damaged transmission gear
- Worn or damaged transmission bearings

CRANKCASE SEPARATION

For Service Information for removal of necessary parts before separating the crankcase (page 12-3).

Remove the bolts, water hose joint and O-ring.

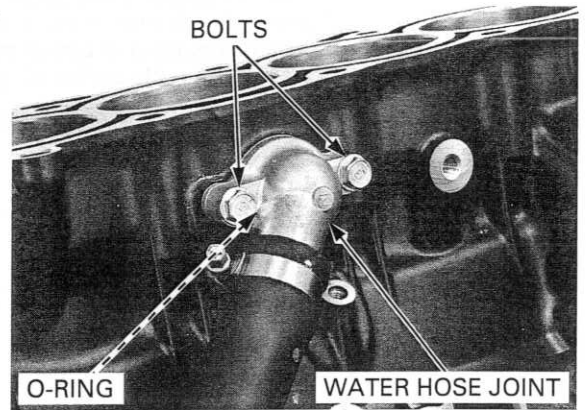

Remove the bolt, oil level plate and oil level finder from the crankcase.

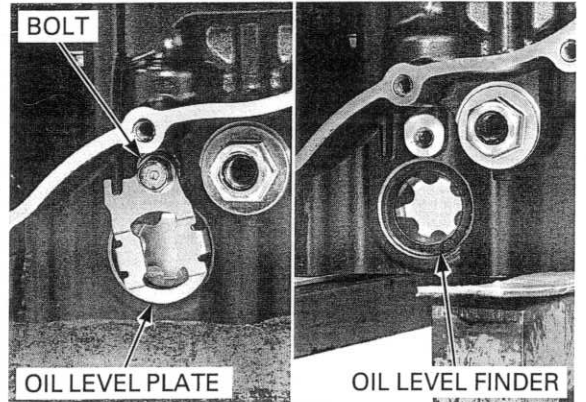

Remove the bolts and sealing washers.

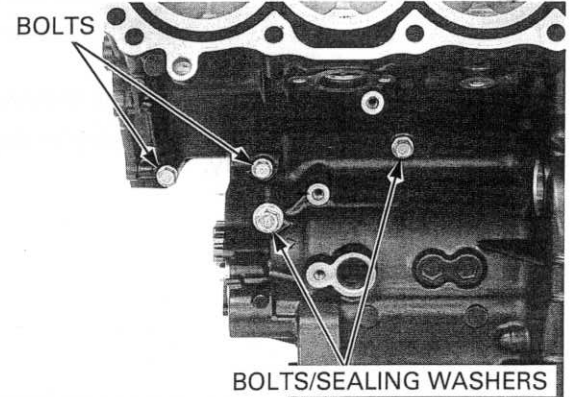

CRANKCASE/TRANSMISSION

Place the engine upside down.
Loosen the 10 mm and 6 mm bolts in a crisscross pattern in two or three steps.
Loosen the 8 mm bolts (main journal bolts) in a crisscross pattern in two or three steps.
Remove the bolts and sealing washers.

Separate the lower crankcase from the upper crankcase.

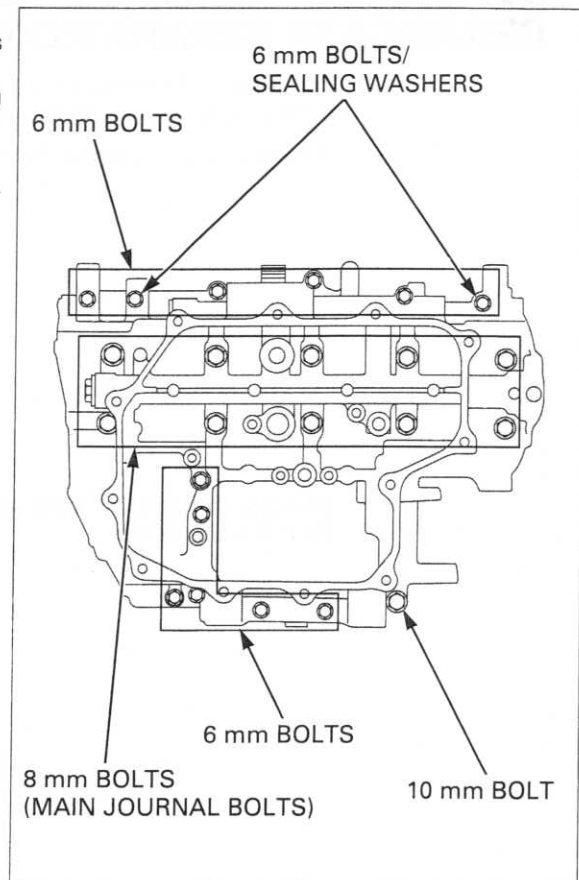

Remove the dowel pins and oil orifices.

Clean any sealant off from the crankcase mating surface.

Clean the oil orifices in solvent thoroughly.

Check the oil orifices for clogs, and replace them if necessary.

DOWEL PINS

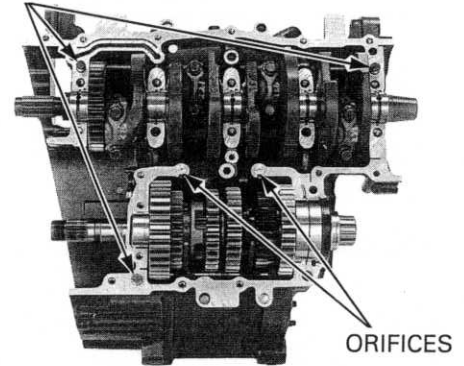

SHIFT FORK/SHIFT DRUM/ TRANSMISSION

REMOVAL/DISASSEMBLY

Separate the crankcase halves (page 12-5).

Remove the countershaft assembly.

Disassemble the countershaft assembly.

Clean all disassembled parts in solvent thoroughly.

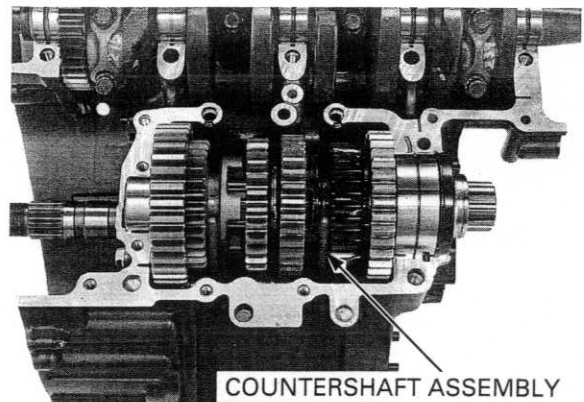

Remove the dowel pin and countershaft bearing set ring.

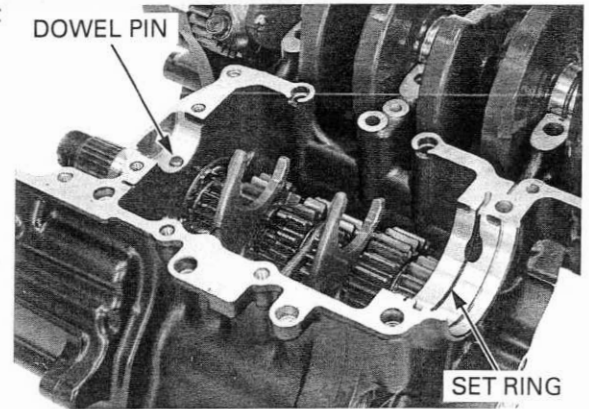

Remove the shift drum bearing set bolts and washers.

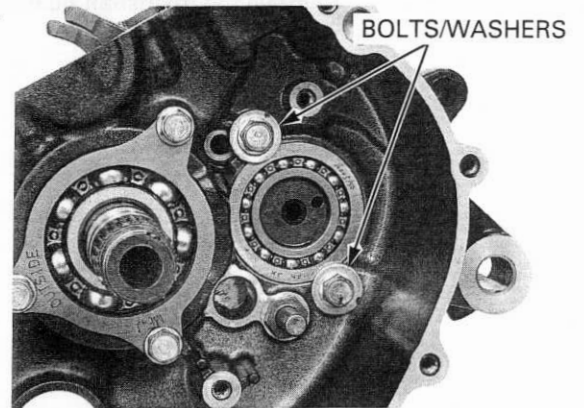

Remove the fork shaft and shift forks.

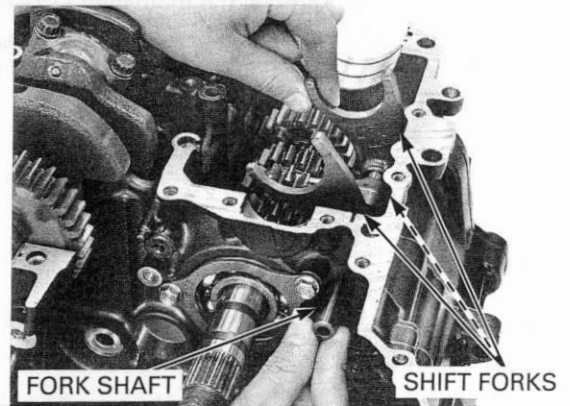

Remove the shift drum and shift drum bearing.

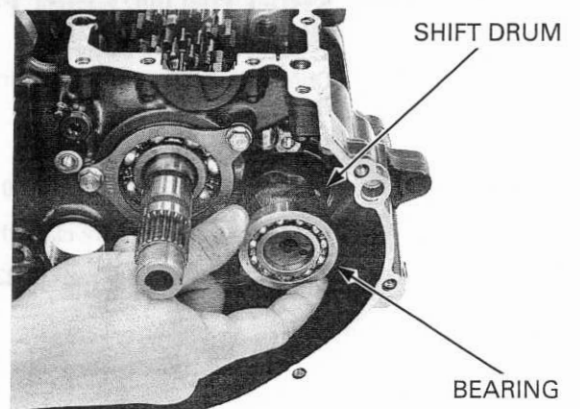

CRANKCASE/TRANSMISSION

Remove the bolts and mainshaft bearing set plate.

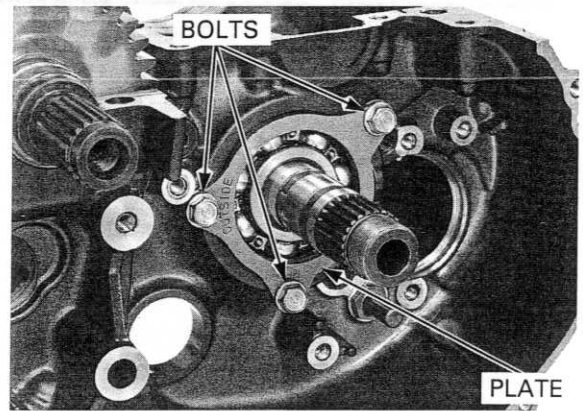

Remove the mainshaft bearing from the crankcase.

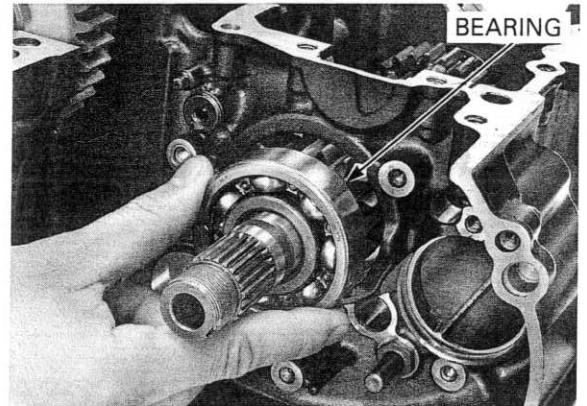

Remove the mainshaft assembly.

Disassemble the mainshaft assembly.
Clean all disassembled parts in solvent thoroughly.

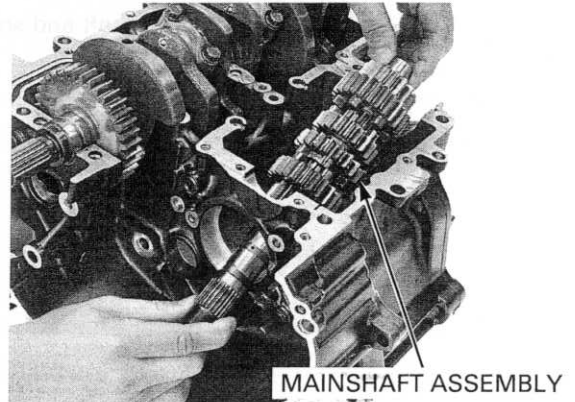

SHIFT DRUM/SHIFT FORK INSPECTION

Check the shift fork guide pin for abnormal wear or damage.

Measure the shift fork I.D.

SERVICE LIMIT: 12.03 mm (0.474 in)

Measure the shift fork claw thickness.

SERVICE LIMIT: 5.9 mm (0.23 in)

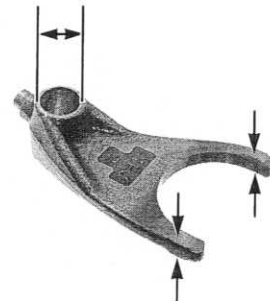

Measure the shift fork shaft O.D.

SERVICE LIMIT: 11.95 mm (0.470 in)

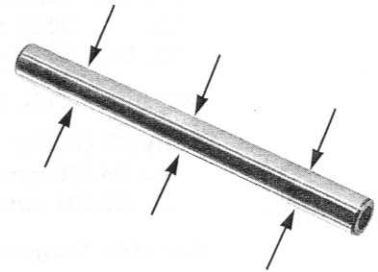

Inspect the shift drum guide grooves for abnormal wear or damage.

Turn the outer race of the shift drum bearing with your finger.

The bearing should turn smoothly and quietly.

Also check that the inner race of the bearing fits tightly on the shift drum.

Replace the bearing if the inner race does not turn smoothly, quietly, or if the inner race fits loosely on the shift drum.

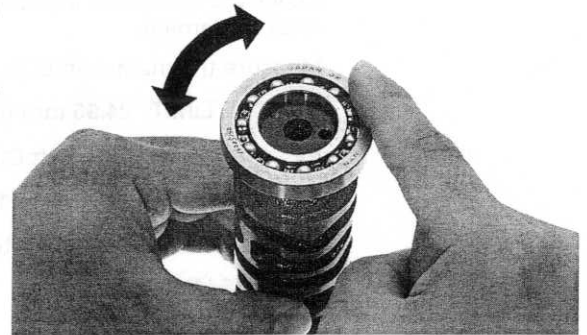

TRANSMISSION INSPECTION

Check the shifter groove and gear dogs for abnormal wear or damage.

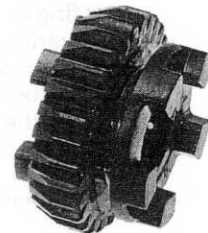

Check the dog holes and teeth for abnormal wear or damage.

Measure the I.D. of each gear.

SERVICE LIMITS:

M5, M6: 28.04 mm (1.104 in)

C1: 24.04 mm (0.946 in)

C2, C3, C4: 31.04 mm (1.222 in)

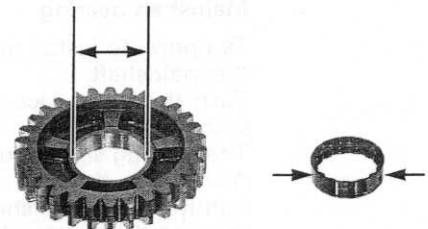

CRANKCASE/TRANSMISSION

Measure the O.D. of each gear bushing.

SERVICE LIMITS:

- M5, M6: 27.94 mm (1.100 in)
- C2: 30.94 mm (1.218 in)
- C3, C4: 30.93 mm (1.218 in)

Measure the I.D. of each gear bushing.

SERVICE LIMITS:

- M5: 25.016 mm (0.9849 in)
- C2: 28.021 mm (1.1032 in)

Calculate the gear-to-bushing clearance.

SERVICE LIMITS:

- M5, M6: 0.10 mm (0.004 in)
- C2: 0.10 mm (0.004 in)
- C3, C4: 0.11 mm (0.004 in)

Check the mainshaft and countershaft for abnormal wear or damage.

Measure the mainshaft O.D. at the M5 gear.

SERVICE LIMIT: 24.96 mm (0.983 in)

Measure the countershaft O.D. at the C2 gear.

SERVICE LIMIT: 27.96 mm (1.101 in)

Calculate the gear bushing-to-shaft clearance.

SERVICE LIMITS:

- M5: 0.06 mm (0.002 in)
- C2: 0.06 mm (0.002 in)

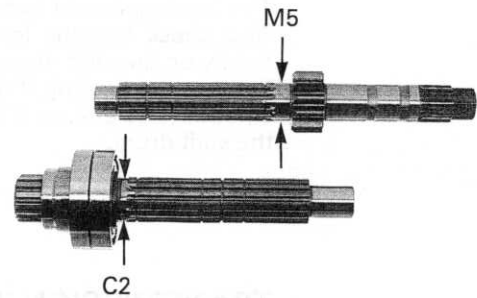
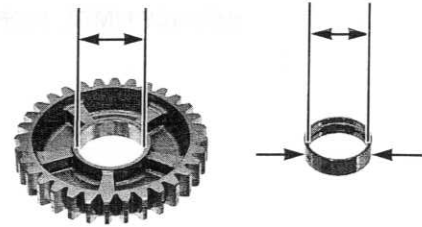

Countershaft bearing

Turn the outer race of countershaft bearing with your finger.

The bearing should turn smoothly and quietly.

Also check that the bearing inner race fits tightly on the countershaft.

Replace the countershaft, collar, and bearing as an assembly, if the race does not turn smoothly, quietly, or if the inner race fits loosely on the countershaft.

- The countershaft bearing cannot be replaced. If the countershaft bearing is faulty, replace the countershaft as an assembly.

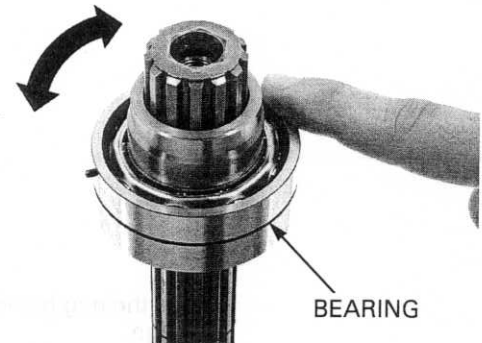

Mainshaft bearing

Temporarily install the left mainshaft bearing onto the mainshaft.

Turn the outer race of the left mainshaft bearing with your finger.

The bearing should turn smoothly and quietly.

Also check that the inner race of the bearing fits tightly on the mainshaft.

Replace the bearing if the inner race does not turn smoothly, quietly, or if the inner race fits loosely on the mainshaft.

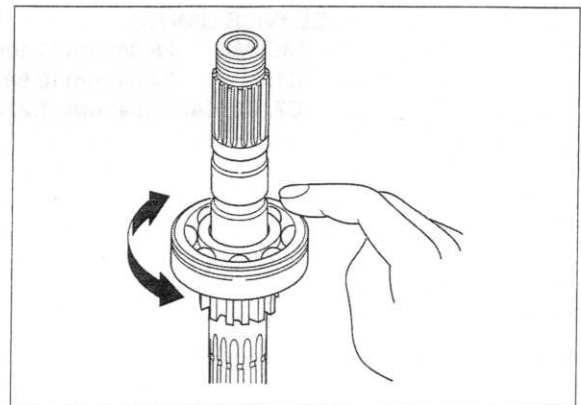

Turn the inner race of the right mainshaft bearing with your finger.
 The bearing should turn smoothly and quietly.
 Also check that the outer race of the bearing fits tightly in the crankcase.
 Replace the bearing if the inner race does not turn smoothly, quietly, or if the outer race fits loosely in the crankcase.

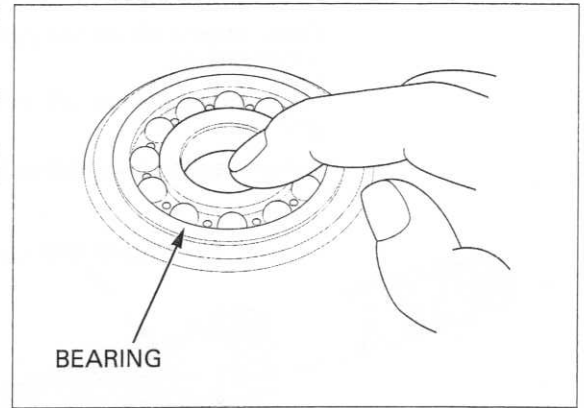

MAINSHAFT BEARING REPLACEMENT

Remove the following:

- Crankshaft (page 13-5)
- Piston (page 13-14)

Remove the mainshaft bearing using the special tools as shown.

TOOLS:

- | | |
|-----------------------------------|-------------------------|
| Bearing remover set, 20 mm | 07936-3710600 |
| Remover weight | 07741-0010201 or |
| | 07936-371020A |
| | (U.S.A. only) |
| Remover handle | 07936-3710100 |

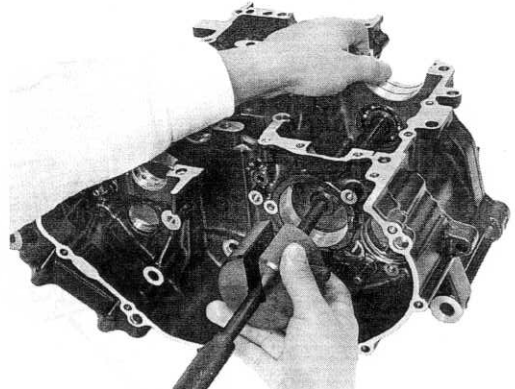

Drive in a new bearing squarely with the marks facing toward the inside of the crankcase.

Drive a new bearing into the left crankcase using the special tools.

TOOLS:

- | | |
|-------------------------------|----------------------|
| Driver | 07949-3710001 |
| Attachment, 42 x 47 mm | 07746-0010300 |
| Pilot, 20 mm | 07746-0040500 |

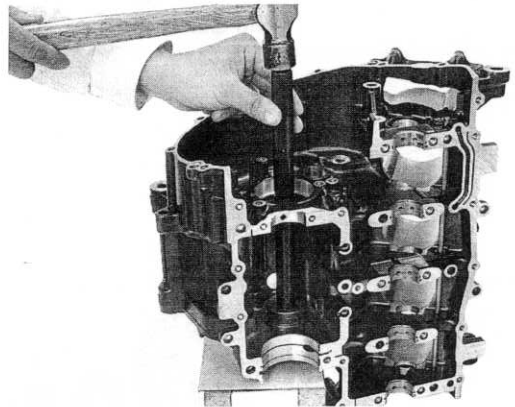

CRANKCASE/TRANSMISSION

TRANSMISSION ASSEMBLY

Apply engine oil to the gear teeth, sliding surface and bushings.

Apply molybdenum oil solution to the shift fork grooves.

Assemble the mainshaft and countershaft.

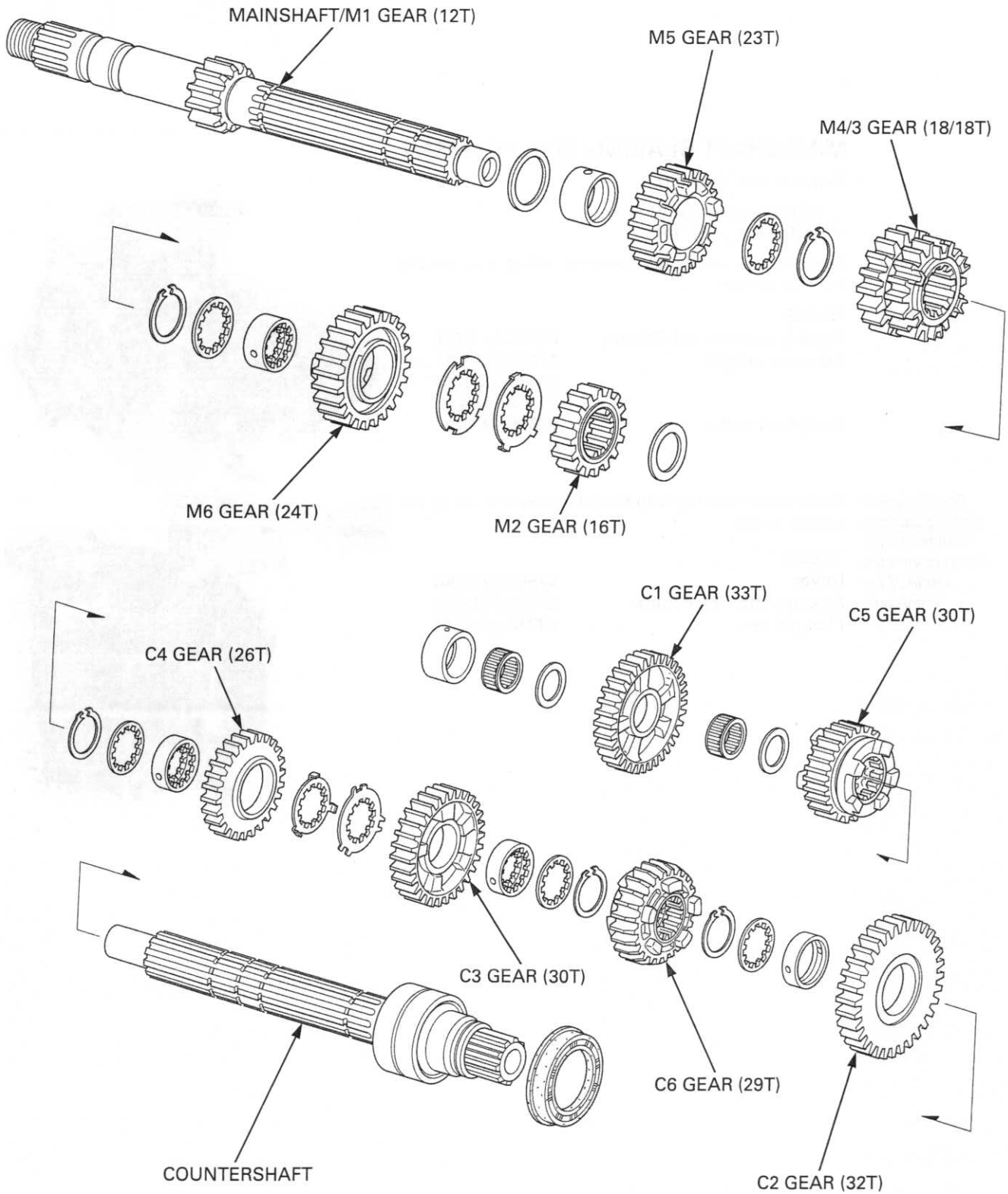

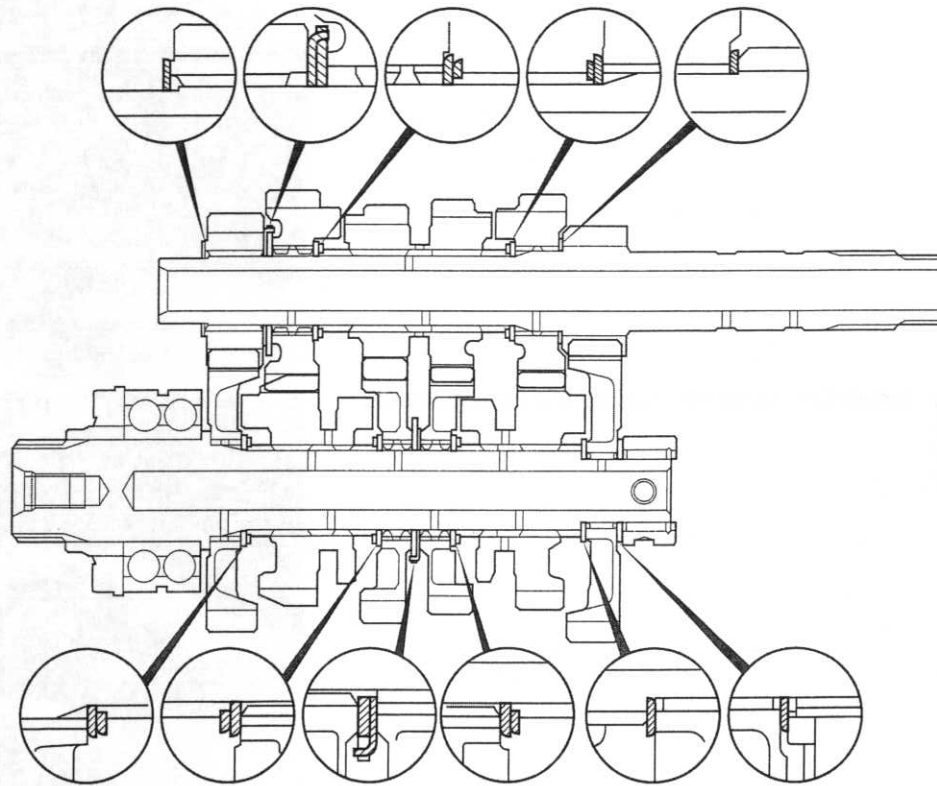

Assemble the transmission gear and shafts.

- Coat each gear with clean engine oil and check for smooth movement.
- Align the lock washer tabs with the spline washer grooves.

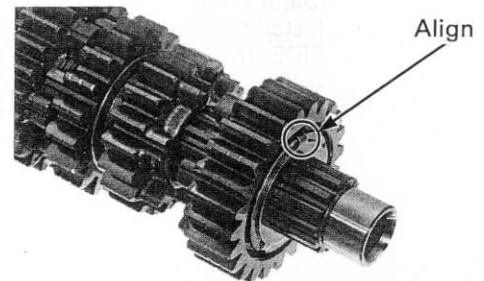

- Always install the thrust washers and snap rings with the chamfered (rolled) edge facing away from the thrust load.
- Install the snap rings so that their end gap aligns with the groove of the splines.
- Make sure that the snap rings are fully seated in the shaft groove after installing them.

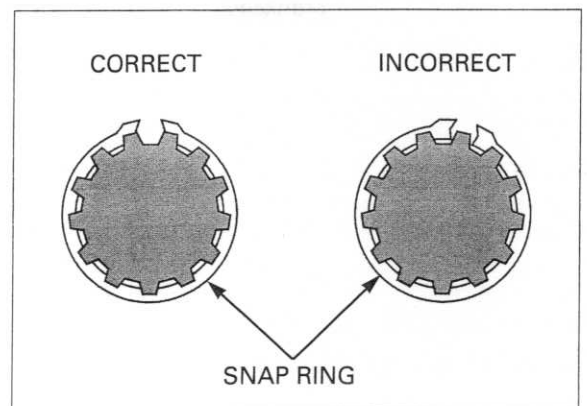

CRANKCASE/TRANSMISSION

INSTALLATION

Install the mainshaft assembly into the crankcase.

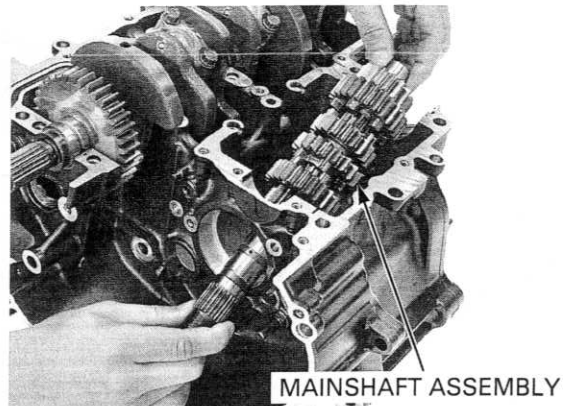

Install the bearing into the crankcase with the marked side facing out.

Install the mainshaft bearing into the crankcase.

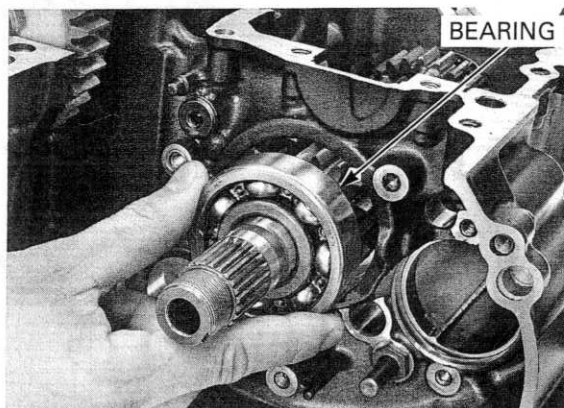

Apply locking agent to the set plate bolt threads (page 1-19).

Install the mainshaft bearing set plate with its "OUT SIDE" mark facing out.

Tighten the set plate bolts to the specified torque.

TORQUE: 12 N·m (1.2 kgf·m, 9 lbf·ft)

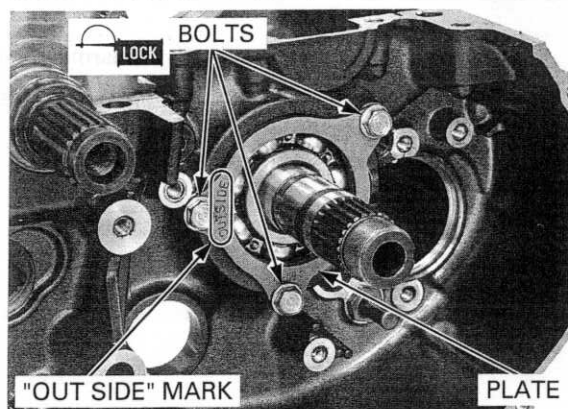

Install the shift drum and shift drum bearing into the crankcase.

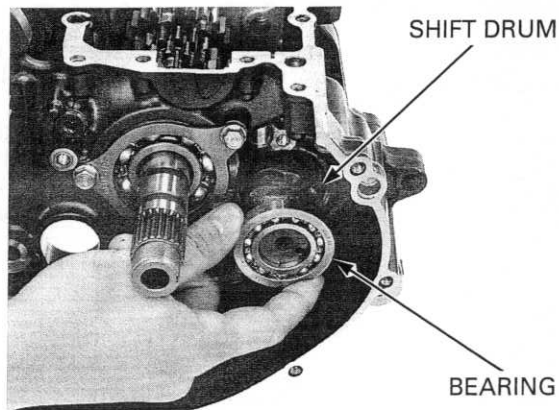

The shift forks have the following identification marks:

- "L" for left
- "R" for right
- "C" for center

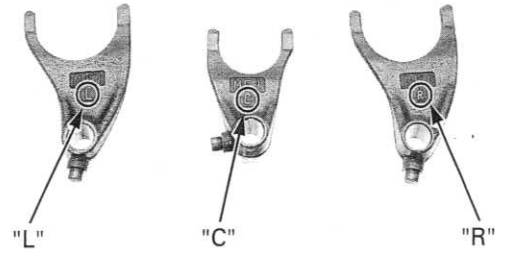

Install the shift forks into the shift drum guide grooves with the identification marks facing toward the right side of the engine and insert the fork shaft.

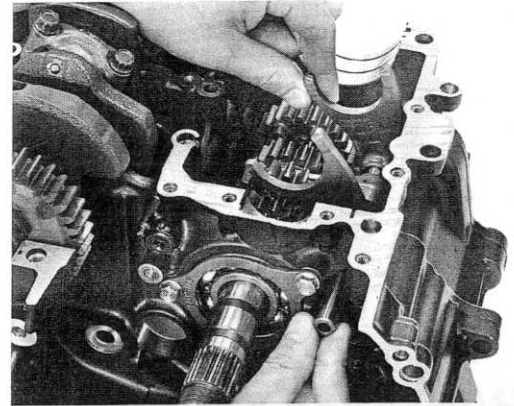

Apply locking agent to the shift drum bearing set bolt threads (page 1-19).

Tighten the bolts/washers to the specified torque.

TORQUE: 12 N·m (1.2 kgf·m, 9 lbf·ft)

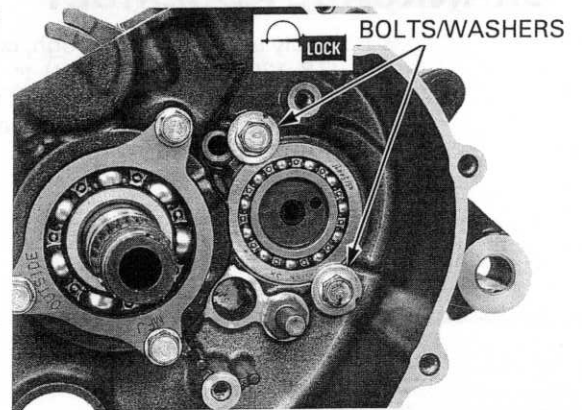

Install the dowel pin onto the upper crankcase hole.

Install the countershaft bearing set ring onto the upper crankcase groove.

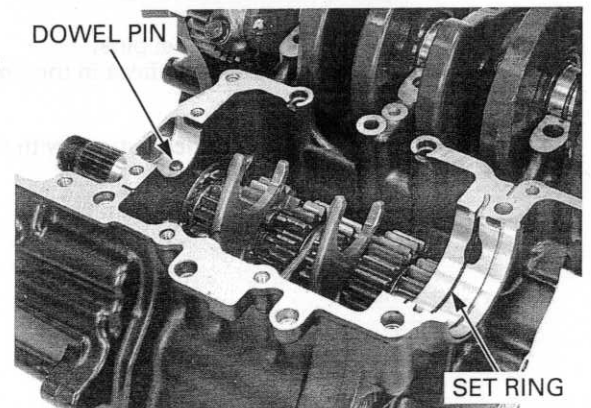

CRANKCASE/TRANSMISSION

Install the countershaft assembly by aligning the countershaft bearing groove with the set ring on the crankcase, and bearing cap hole with the dowel pin.

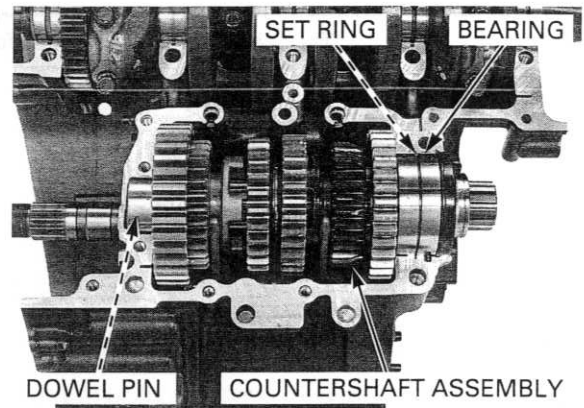

Also align the countershaft bearing stopper pin with the groove in the crankcase.

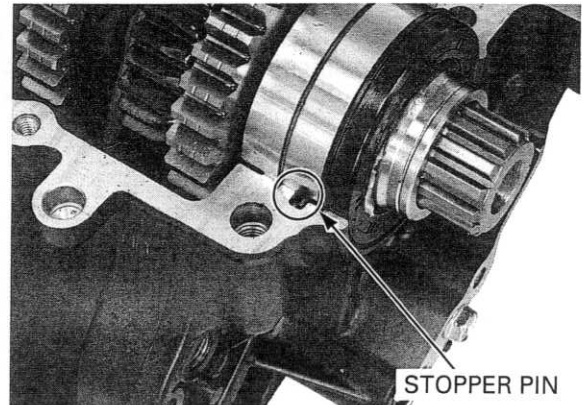

CRANKCASE ASSEMBLY

Apply a light, but thorough, coating of liquid sealant (TB 1207B or equivalent) to the crankcase mating surface. Do not apply sealant to the crankcase 8 mm bolt (main journal bolt) area and the oil passage area as shown.

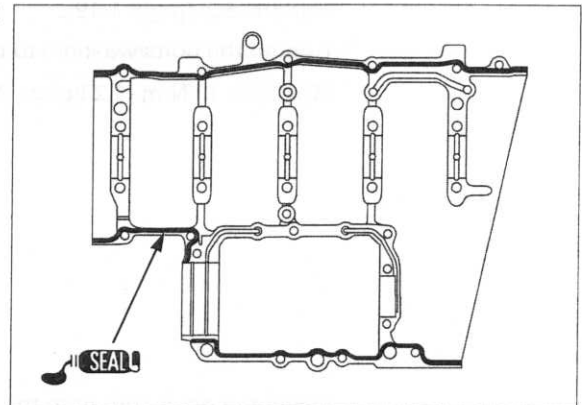

Install the dowel pins.
Install the oil orifices in the upper crankcase.

NOTE:
Align the orifice cut-out with the crankcase.

DOWEL PINS

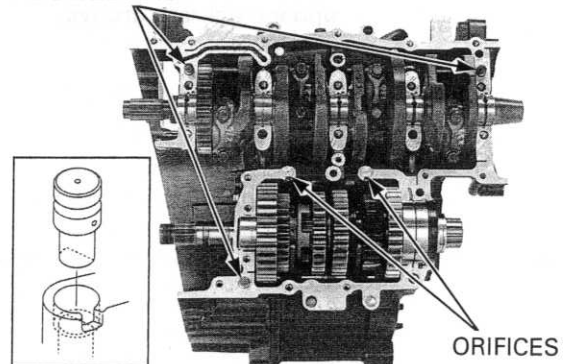

- Tighten the crankcase 8 mm bolts (main journal bolts) using the Plastic Region Tightening Method described below.
- Do not reuse the crankcase 8 mm bolts (main journal bolts), because the correct axial tension will not be obtained.
- The crankcase 8 mm bolts (main journal bolts) are pre-coated with an oil additive for axial tension stability. Do not remove the oil additive from the new 8 mm bolts (main journal bolts) surface.

Install the lower crankcase onto the upper crankcase.

Install new crankcase 8 mm bolts (main journal 8 mm bolts).

Loosely install all the crankcase bolts.

8 mm BOLTS (MAIN JOURNAL BOLTS) 

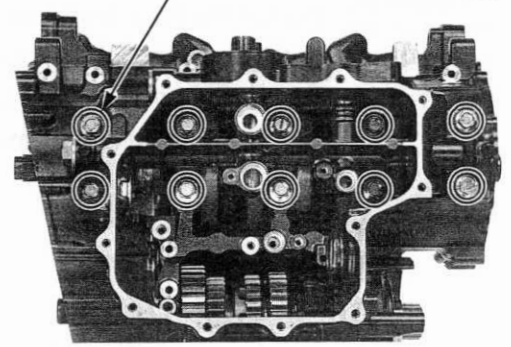

PLASTIC REGION TIGHTENING METHOD:

Make sure the upper and lower crankcase are seated securely.

Tighten the crankcase 8 mm bolts (main journal bolts) as follows:

Tighten the crankcase 8 mm bolts (main journal bolts) in numerical order as shown in the illustration in two or three steps to the specified torque.

Further tighten the crankcase 8 mm bolts (main journal bolts) 120°.

TORQUE: 15 N·m (1.5 kgf·m, 11 lbf·ft) + 120°

Tighten the 10 mm bolt to the specified torque.

TORQUE: 39 N·m (4.0 kgf·m, 29 lbf·ft)

From the inside to outside, tighten the 6 mm bolts/sealing washers to the specified torque.

TORQUE: 12 N·m (1.2 kgf·m, 9 lbf·ft)

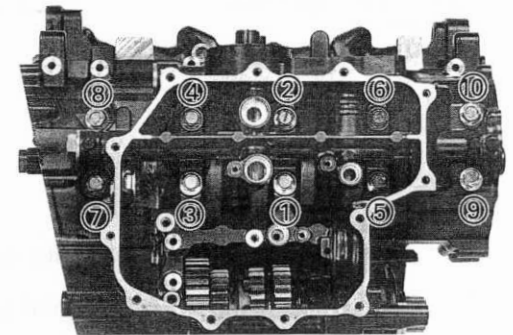

6 mm BOLTS/
SEALING WASHERS 

6 mm BOLTS

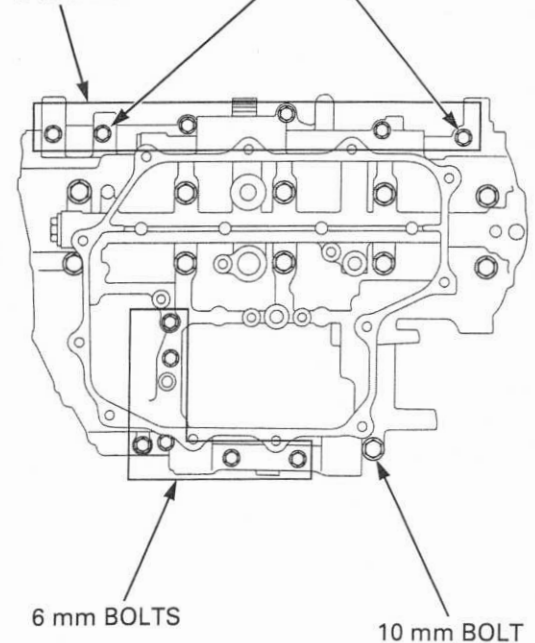

6 mm BOLTS

10 mm BOLT

CRANKCASE/TRANSMISSION

Place the engine with the lower side down.

The sealing washer locations are indicated on the upper crankcase using the "△" mark.

Install the 6 mm bolts with a new sealing washer.

Tighten the 6 mm bolts securely.

Install the 8 mm bolt with a new sealing washer.

Tighten the 8 mm bolt to the specified torque.

TORQUE: 24 N·m (2.4 kgf·m, 18 lbf·ft)

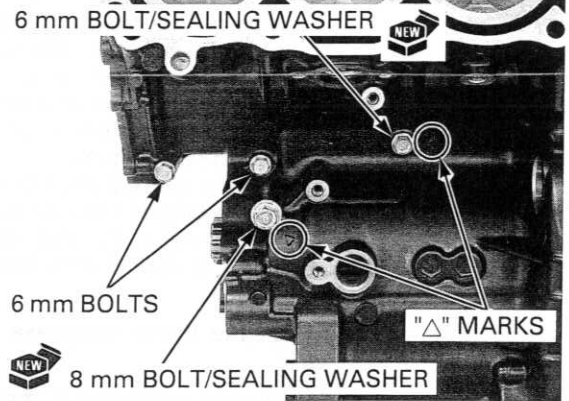

When installing a new oil level finder, do not press the clear surface.

Install a new oil level finder into the crankcase securely.

Apply locking agent to the oil level plate bolt threads (page 1-19).

Align the oil level plate groove with the crankcase tab.

Install the oil level plate and tighten the bolts securely.

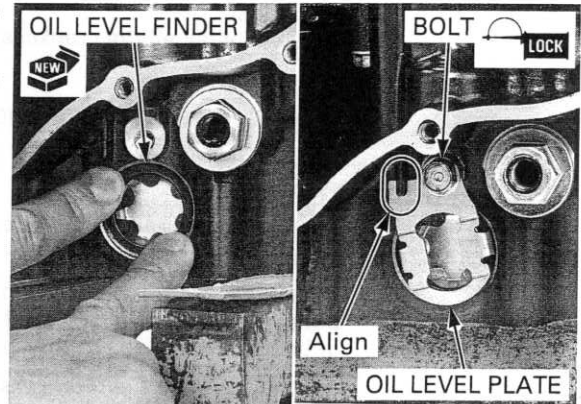

Install a new O-ring into the groove of the water hose joint.

Install the water hose joint to the cylinder block.

Tighten the bolts securely.

Install the removed parts in the reverse order of removal.

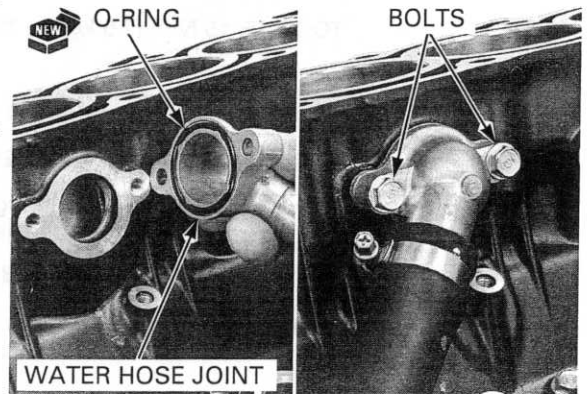

13. CRANKSHAFT/PISTON/CYLINDER

COMPONENT LOCATION	13-2	MAIN JOURNAL BEARING	13-8
SERVICE INFORMATION	13-3	CRANKPIN BEARING	13-11
TROUBLESHOOTING	13-4	PISTON/CYLINDER	13-14
CRANKSHAFT	13-5		

CRANKSHAFT/PISTON/CYLINDER

COMPONENT LOCATION

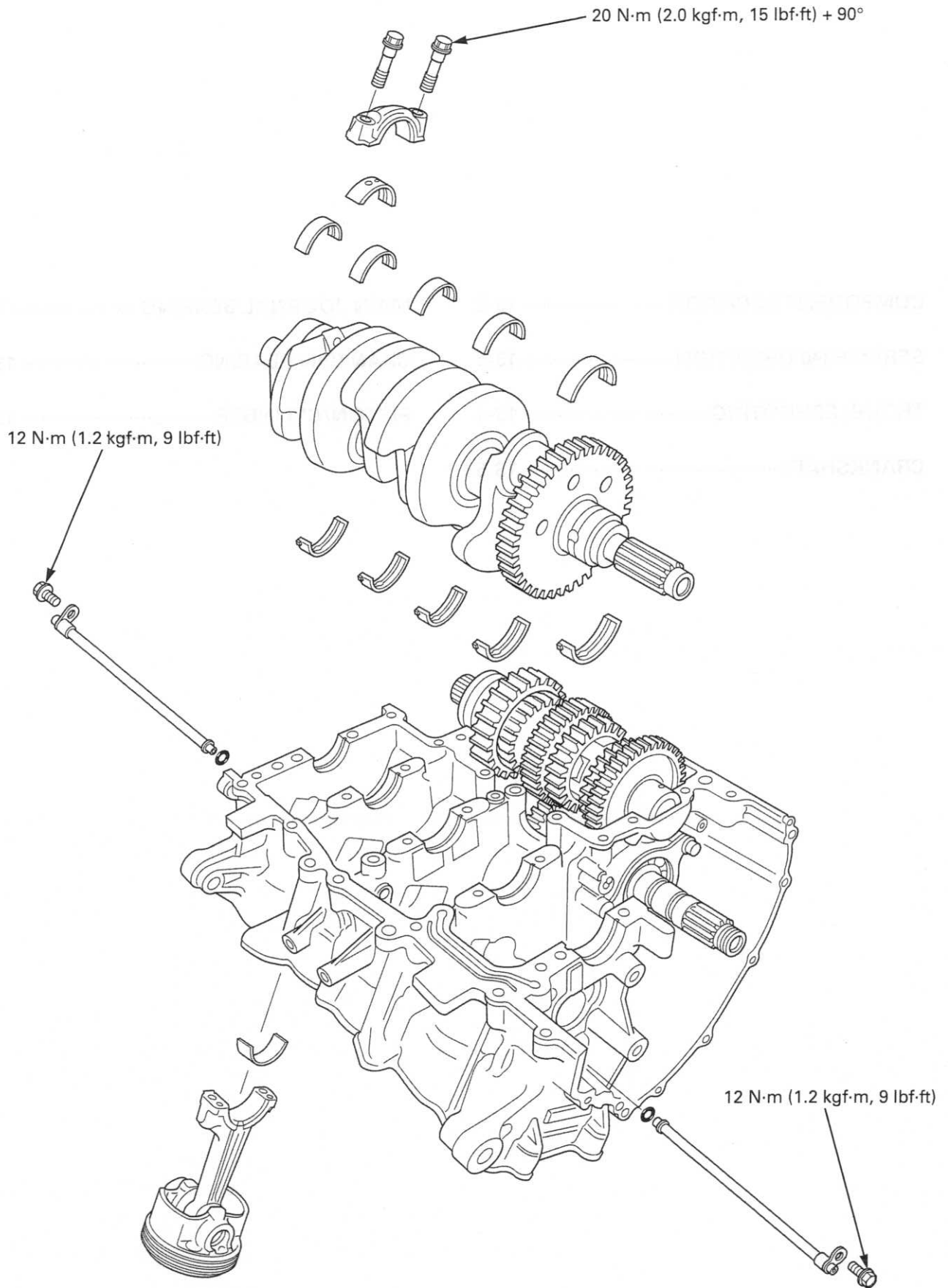

SERVICE INFORMATION

GENERAL

- The crankcase must be separated to service the following:
 - Crankshaft (page 13-5)
 - Piston/cylinder (page 13-14)
- Mark and store the connecting rods, bearing caps and bearing inserts to be sure of their correct locations for reassembly.
- The crankpin and main journal bearing inserts are select fit and are identified by color codes. Select replacement bearings from the code tables. After selecting new bearings, recheck the oil clearance with a plastigauge. Incorrect oil clearance can cause major engine damage.
- Clean the oil passages in the upper crankcase with compressed air before installing the pistons.

SPECIFICATIONS

Unit: mm (in)

ITEM		STANDARD	SERVICE LIMIT	
Crankshaft	Connecting rod side clearance	0.15 – 0.30 (0.006 – 0.012)	0.35 (0.014)	
	Crankpin bearing oil clearance	0.028 – 0.052 (0.0011 – 0.0020)	0.06 (0.002)	
	Main journal bearing oil clearance	0.020 – 0.038 (0.0008 – 0.0015)	0.05 (0.002)	
	Runout	–	0.05 (0.002)	
Piston, piston rings	Piston O.D. at 6 mm (0.2 in) from bottom	66.965 – 66.985 (2.6364 – 2.6372)	66.90 (2.634)	
	Piston pin bore I.D.	15.030 – 15.044 (0.5917 – 0.5923)	15.07 (0.593)	
	Piston pin O.D.	14.994 – 15.000 (0.5903 – 0.5906)	14.98 (0.590)	
	Piston-to-piston pin clearance	0.03 – 0.05 (0.001 – 0.002)	0.09 (0.004)	
	Piston ring end gap	Top	0.10 – 0.20 (0.004 – 0.008)	0.4 (0.02)
		Second	0.21 – 0.31 (0.008 – 0.012)	0.5 (0.02)
		Oil (side rail)	0.2 – 0.7 (0.01 – 0.03)	1.0 (0.04)
	Piston ring-to-ring groove clearance	Top	0.030 – 0.060 (0.0012 – 0.0024)	0.10 (0.004)
Second		0.115 – 0.150 (0.0045 – 0.0059)	0.08 (0.003)	
Cylinder	I.D.	67.000 – 67.015 (2.6378 – 2.6384)	67.10 (2.642)	
	Out of round	–	0.10 (0.004)	
	Taper	–	0.10 (0.004)	
	Warpage	–	0.10 (0.004)	
Cylinder-to-piston clearance		0.015 – 0.050 (0.0006 – 0.0020)	0.10 (0.004)	
Connecting rod small end I.D.		15.030 – 15.044 (0.5917 – 0.5923)	15.05 (0.593)	
Connecting rod-to-piston pin clearance		0.03 – 0.05 (0.001 – 0.002)	0.07 (0.003)	

TORQUE VALUES

Crankpin bearing cap bolt (new)	20 N·m (2.0 kgf·m, 15 lbf·ft) + 90°	Apply oil to the threads and seating surface
Crankpin bearing cap bolt (retightening)	14 N·m (1.4 kgf·m, 10 lbf·ft) + 90°	Apply oil to the threads and seating surface
Crankcase 8 mm bolt (main journal bolt)	15 N·m (1.5 kgf·m, 11 lbf·ft) + 120°	See page 13-9 Replace with a new one
Oil jet pipe mounting bolt	12 N·m (1.2 kgf·m, 9 lbf·ft)	Apply locking agent to the threads

CRANKSHAFT/PISTON/CYLINDER

TROUBLESHOOTING

Cylinder compression is too low, hard to starting or poor performance at low speed

- Leaking cylinder head gasket
- Worn, stuck or broken piston ring
- Worn or damaged cylinder and piston

Cylinder compression too high, overheating or knocking

- Excessive carbon built-up on piston head or combustion chamber

Excessive smoke

- Worn cylinder, piston or piston ring
- Improper installation of piston rings
- Scored or scratched piston or cylinder wall

Abnormal noise

- Worn piston pin or piston pin hole
- Worn connecting rod small end
- Worn cylinder, piston or piston rings
- Worn main journal bearings
- Worn crankpin bearings

Engine vibration

- Excessive crankshaft runout

CRANKSHAFT

Separate the crankcase halves (page 12-5).

SIDE CLEARANCE INSPECTION

Measure the connecting rod side clearance.

SERVICE LIMIT: 0.35 mm (0.014 in)

If the clearance exceeds the service limit, replace the connecting rod.

Recheck and if still out of limit, replace the crankshaft.

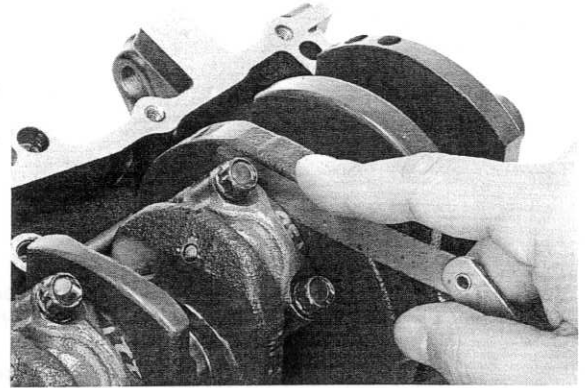

REMOVAL

NOTICE

- Before removal, position all the pistons at TDC (Top Dead Center) to prevent damaging the crankpin with the connecting rod.
- Do not interchange the bearing inserts. They must be installed in their original locations or the correct bearing oil clearance may not be obtained, resulting in engine damage.

Mark the bearing caps and bearings as you remove them to indicate the correct cylinder for reassembly.

Remove the crankpin bearing cap bolts and bearing caps.

Remove the crankshaft.

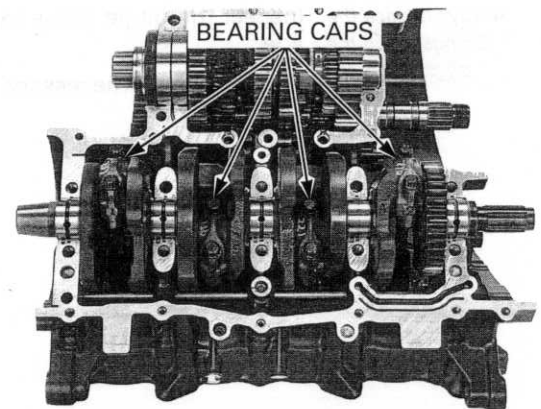

Remove the main journal bearings from both crankcase halves.

NOTICE

Do not interchange the bearing inserts. They must be installed in their original locations or the correct bearing oil clearance may not be obtained, resulting in engine damage.

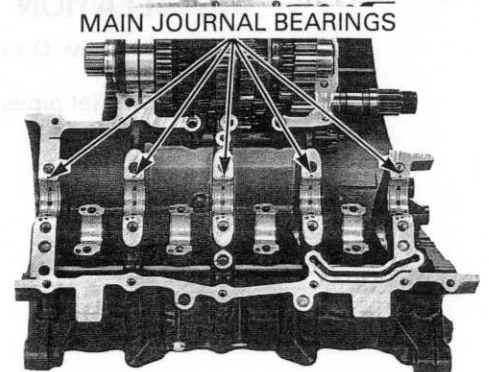

CRANKSHAFT/PISTON/CYLINDER

Remove the bolts, oil jet pipes and O-rings from the upper crankcase.

Clean the oil jet pipes thoroughly.

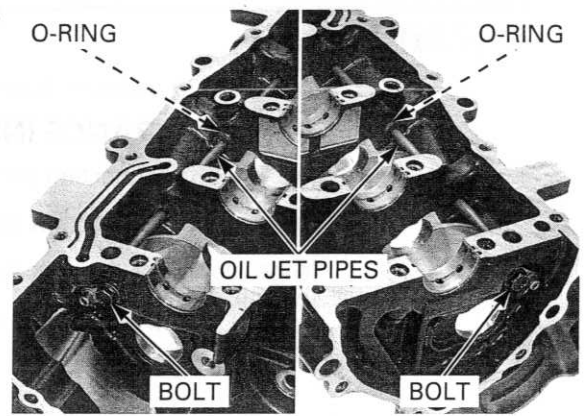

INSPECTION

Support the crankshaft on both end journals.
Set a dial gauge on the center main journal of the crankshaft.
Rotate the crankshaft two revolutions and read the runout.

SERVICE LIMIT: 0.05 mm (0.002 in)

Check the primary drive gear teeth for abnormal wear or damage.

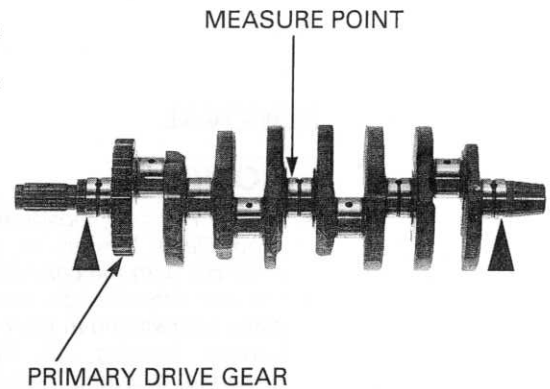

Always replace the O-rings when the oil jet pipes are removed.

Inspect the oil jet pipes for clogs, bending or damage.

Replace them if necessary.

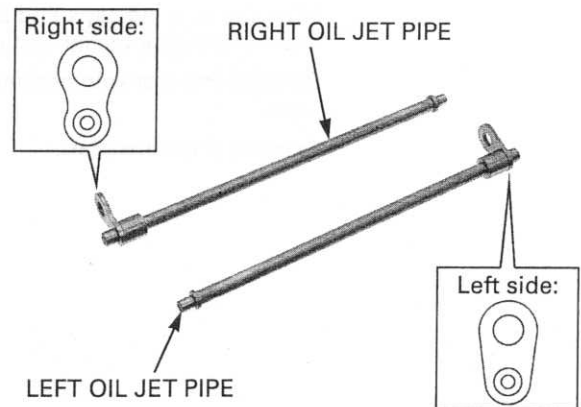

INSTALLATION

Apply oil to new O-rings and install them to the oil jet pipes.

Install the oil jet pipes into the upper crankcase.

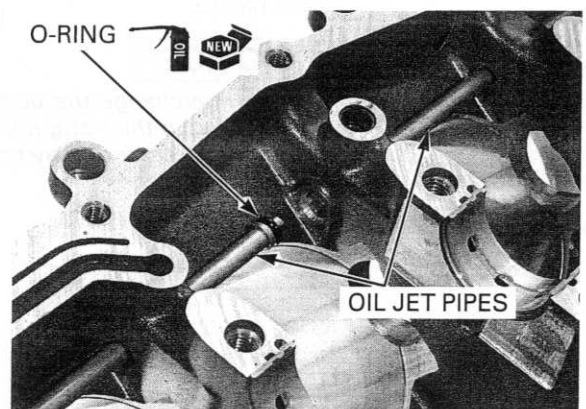

Apply locking agent to the oil jet pipe mounting bolt threads (page 1-19) and tighten them to the specified torque.

TORQUE: 12 N·m (1.2 kgf·m, 9 lbf·ft)

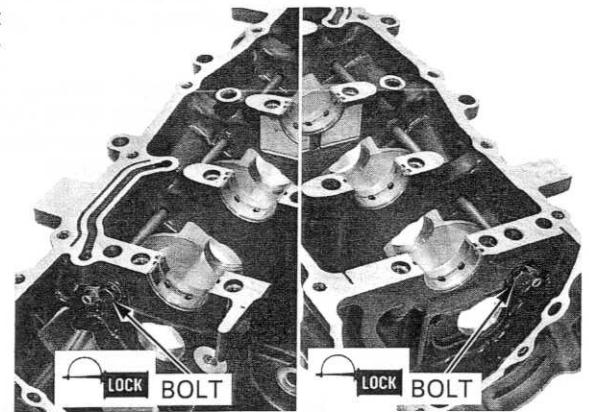

Apply molybdenum oil solution to the main journal bearing sliding surfaces on the upper crankcase and crankpin bearing sliding surfaces on the connecting rods.

The bearing tabs should be aligned with the grooves in the crankcase.

Install the main journal bearings into the original locations.

NOTICE

Do not interchange the bearing inserts. They must be installed in their original locations or the correct bearing oil clearance may not be obtained, resulting in engine damage.

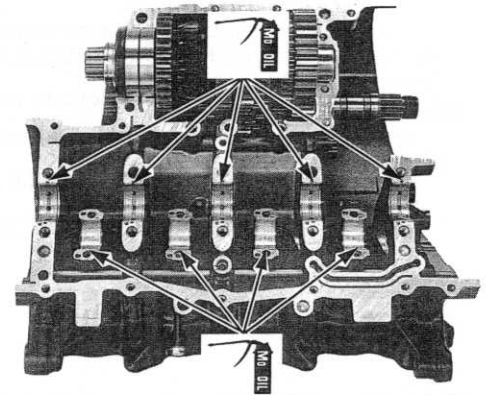

Apply molybdenum oil solution to the main journal thrust surfaces of the crankshaft as shown.

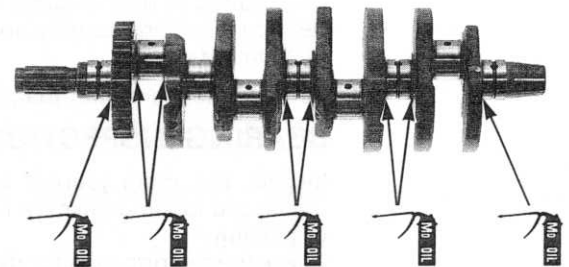

NOTICE

Position all the pistons at TDC (Top Dead Center) to prevent damaging the crankpin with the connecting rod.

Install the crankshaft onto the upper crankcase. Set the connecting rods to the crankpins.

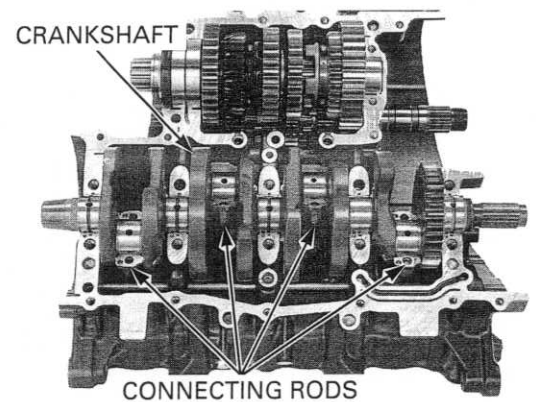

CRANKSHAFT/PISTON/CYLINDER

Apply molybdenum oil solution to the crankpin bearing sliding surfaces on the crankpin bearing caps.

Install the crankpin bearing caps, aligning the dowel pins with the holes in the connecting rods. Be sure each part is installed in its original position, as noted during removal.

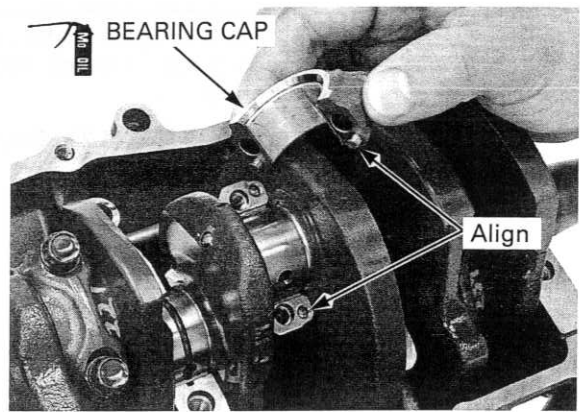

PLASTIC REGION TIGHTENING METHOD:

The crankpin bearing cap bolts cannot be reused. Once the bolts have been loosened replace them with new ones.

Apply oil to new crankpin bearing cap bolt threads and seating surfaces, and install them.

Tighten the bolts in two or three steps alternately.

Further tighten the bolts 90°.

TORQUE: 20 N·m (2.0 kgf·m, 15 lbf·ft) + 90°

Assemble the crankcase halves (page 12-16).

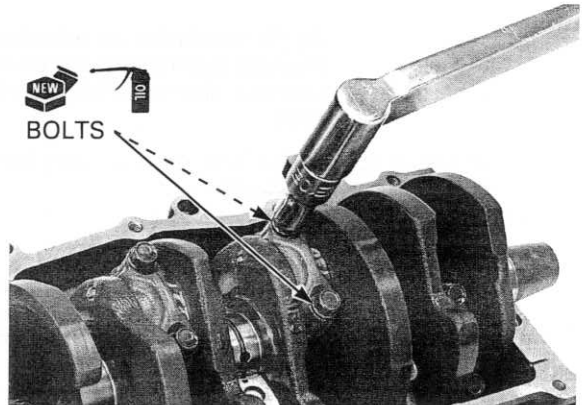

MAIN JOURNAL BEARING

NOTICE

Do not interchange the bearing inserts. They must be installed in their original locations or the correct bearing oil clearance may not be obtained, resulting in engine damage.

Remove the crankshaft (page 13-5).

BEARING INSPECTION

Inspect the main journal bearing inserts on the upper and lower crankcase halves for unusual wear or peeling.

Check the bearing tabs for damage.

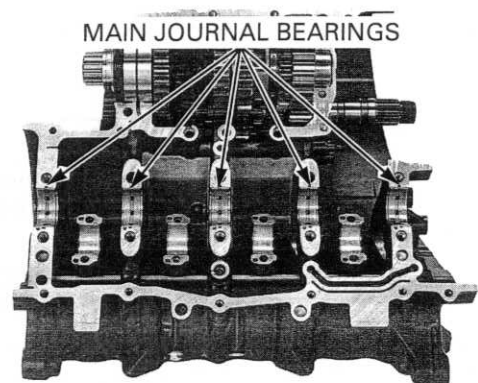

OIL CLEARANCE INSPECTION

Clean off any oil from the bearing inserts and main journals.
 Install the crankshaft onto the upper crankcase.
 Put a strip of plastigauge lengthwise on each main journal avoiding the oil hole.

- Do not rotate the crankshaft during inspection.

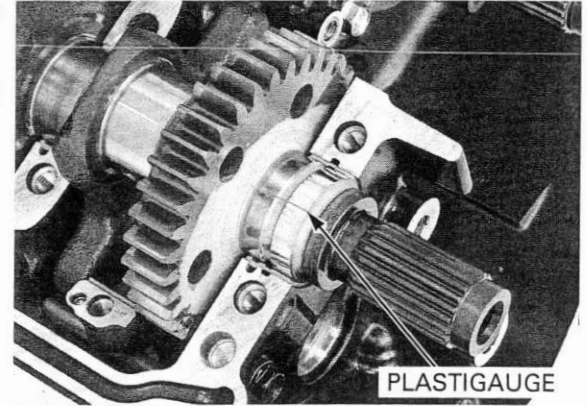

Install the dowel pins and oil orifices onto the upper crankcase.

NOTE:

Align the orifice cut-out with the crankcase.

Install the lower crankcase onto the upper crankcase.

DOWEL PINS

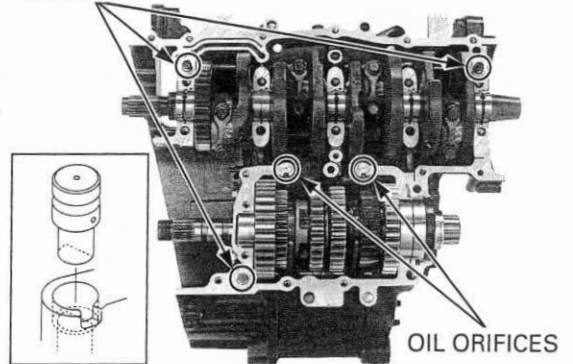

PLASTIC REGION TIGHTENING METHOD:

Install the crankcase 8 mm bolts (main journal 8 mm bolts).

Make sure the upper and lower crankcase are seated securely.

Tighten the crankcase 8 mm bolts (main journal bolts) as follows:

Tighten the crankcase 8 mm bolts (main journal bolts) in numerical order in the illustration in two or three steps to the specified torque.

Further tighten the crankcase 8 mm bolts (main journal bolts) 120°.

TORQUE: 15 N·m (1.5 kgf·m, 11 lbf·ft) + 120°

Remove the crankcase 8 mm bolts (main journal bolts) and lower crankcase, measure the compressed plastigauge at its widest point on each main journal to determine the oil clearance.

SERVICE LIMIT: 0.05 mm (0.002 in)

If the oil clearance exceeds the service limit, select a replacement bearing.

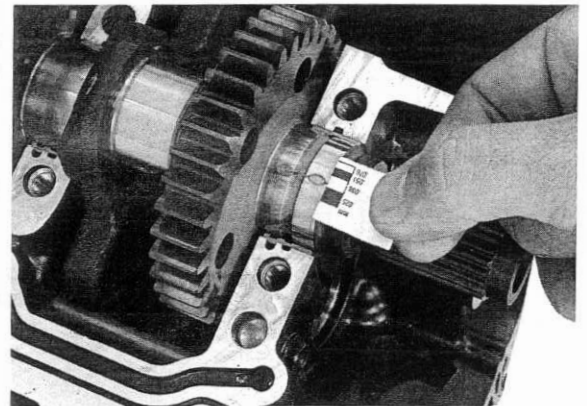
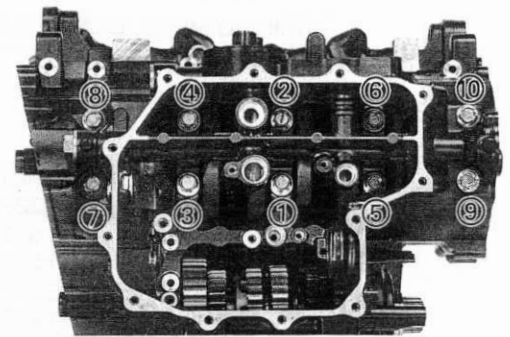

CRANKSHAFT/PISTON/CYLINDER

BEARING SELECTION

Letters (A, B or C) on the left side of upper crankcase are the codes for the bearing support I.D.s from left to right.

Record the crankcase bearing support I.D. code letters from the pad on the left side of the upper crankcase as shown.

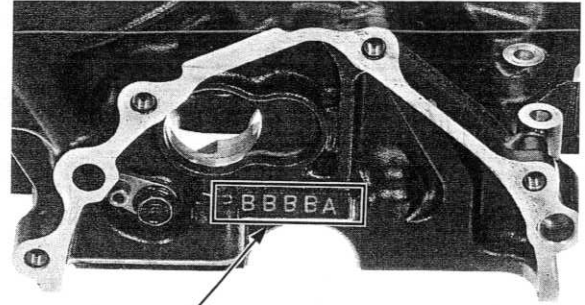

CRANKCASE I.D. CODE

Numbers (1, 2 or 3) on the crank weight are the codes for the main journal O.D.s from left to right.

Record the corresponding main journal O.D. code numbers from the crank weight.

MAIN JOURNAL O.D. CODE

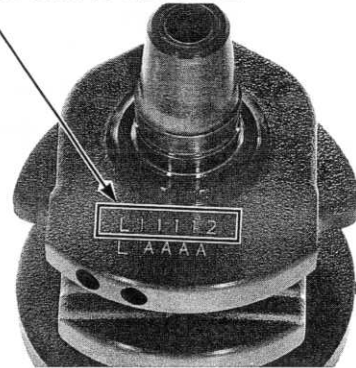

Cross reference the main journal and bearing support codes to determine the replacement bearing color code.

MAIN JOURNAL BEARING SELECTION TABLE:

			BEARING SUPPORT I.D. CODE		
			A	B	C
			34.000 – 34.006 mm (1.3386 – 1.3388 in)	34.006 – 34.012 mm (1.3388 – 1.3391 in)	34.012 – 34.018 mm (1.3391 – 1.3393 in)
MAIN JOURNAL O.D. CODE	1	30.999 – 31.005 mm (1.2204 – 1.2207 in)	Pink	Yellow	Green
	2	30.993 – 30.999 mm (1.2202 – 1.2204 in)	Yellow	Green	Brown
	3	30.987 – 30.993 mm (1.2200 – 1.2202 in)	Green	Brown	Black

BEARING THICKNESS:

Black: Thickest
 Brown:
 Green: ↓
 Yellow:
 Pink: Thinnest

IDENTIFICATION COLOR

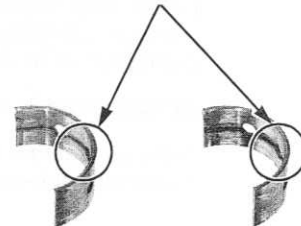

NOTICE

After selecting new bearings, recheck the clearance with a plastigauge. Incorrect clearance can cause severe engine damage.

BEARING INSTALLATION

Clean the bearing outer surfaces and crankcase bearing supports.

Apply molybdenum oil solution to the main journal bearing sliding surfaces on the upper crankcase.

Install the main journal bearing inserts onto the crankcase bearing supports, aligning each tab with each groove.

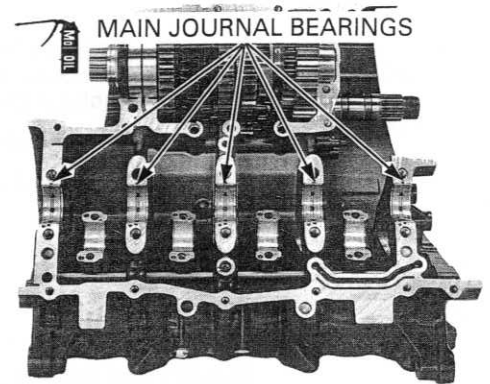

CRANKPIN BEARING

NOTICE

Do not interchange the bearing inserts. They must be installed in their original locations or the correct bearing oil clearance may not be obtained, resulting in engine damage.

Remove the crankshaft (page 13-5).

BEARING INSPECTION

Check the bearing inserts for unusual wear or peeling.

Check the bearing tabs for damage.

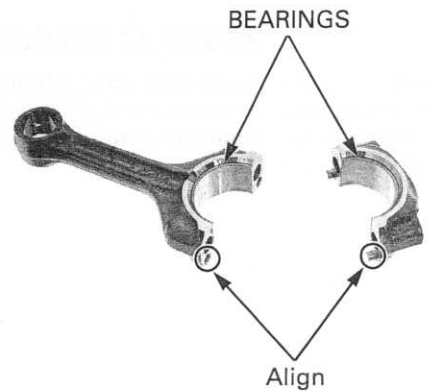

OIL CLEARANCE INSPECTION

Clean off any oil from the bearing inserts and crankpins.

Carefully install the crankshaft onto the upper crankcase.

Set the connecting rods onto the crankpins.

Put a strip of plastigauge lengthwise on each crankpin avoiding the oil hole.

- Do not rotate the crankshaft during inspection.

PLASTIGAUGE

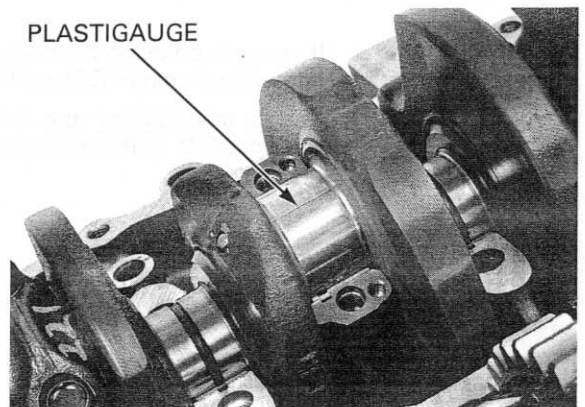

CRANKSHAFT/PISTON/CYLINDER

Carefully install the crankpin bearing caps, aligning the dowel pins with the holes in the connecting rods.

Use the removed crankpin bearing cap bolts when checking the oil clearance.

Apply oil to the crankpin bearing cap bolt threads and seating surfaces and install the bolts. Tighten the bolts in two or three steps alternately.

Further tighten the bolts 90°.

TORQUE: 14 N·m (1.4 kgf·m, 10 lbf·ft) + 90°

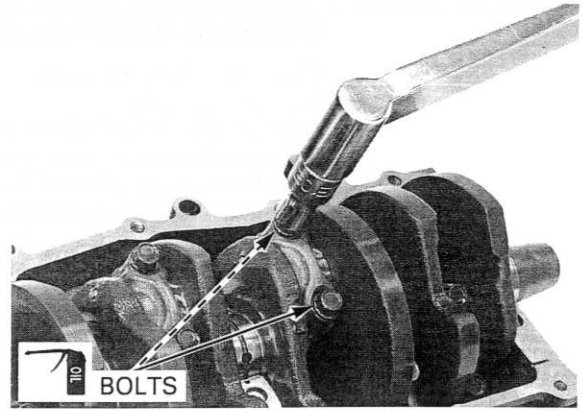

Remove the bearing caps and measure the compressed plastigauge at its widest point on the crankpin to determine the oil clearance.

SERVICE LIMIT: 0.06 mm (0.002 in)

If the oil clearance exceeds the service limit, select the correct replacement bearings.

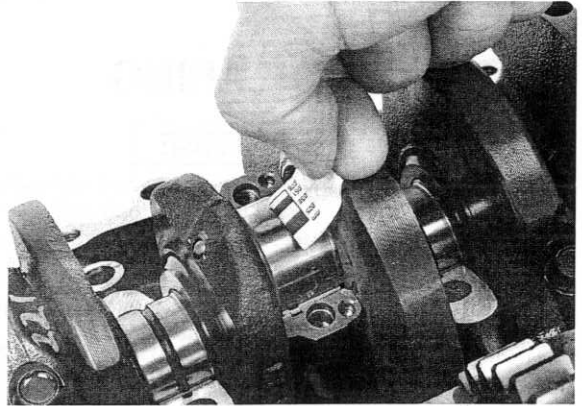

BEARING SELECTION

Numbers (1 or 2) on the connecting rods are the codes for the connecting rod I.D.

Record the connecting rod I.D. code number (1 or 2) or measure the I.D. with the crankpin bearing cap installed without bearing inserts.

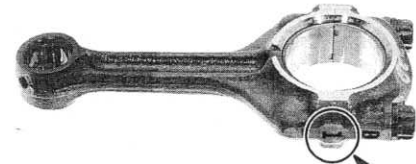

I.D. CODE

Letters (A or B) on the crankweight are the codes for the crankpin O.D.s from left to right.

If you are replacing the crankshaft, record the corresponding crankpin O.D. code letter (A or B).

If you are reusing the crankshaft, measure the crankpin O.D. with a micrometer.



CRANKPIN O.D. CODE

Cross-reference the connecting rod and crankpin codes to determine the replacement bearing color code.

CRANKPIN BEARING SELECTION TABLE:

			CONNECTING ROD I.D. CODE	
			1	2
			33.500 – 33.508 mm (1.3189 – 1.3192 in)	33.508 – 33.516 mm (1.3192 – 1.3195 in)
CRANK PIN O.D. CODE	A	30.995 – 31.003 mm (1.2203 – 1.2206 in)	Yellow	Green
	B	30.984 – 30.995 mm (1.2198 – 1.2203 in)	Green	Brown

BEARING THICKNESS:

Brown: **Thickest**
 Green: ↓
 Yellow: **Thinnest**

NOTICE

After selecting new bearings, recheck the clearance with a plastigauge. Incorrect clearance can cause severe engine damage.

IDENTIFICATION COLOR

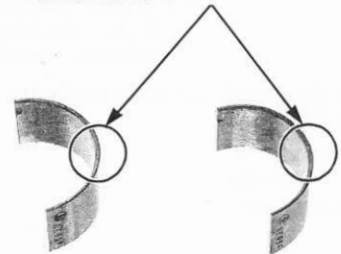

BEARING INSTALLATION

Clean the bearing outer surfaces, crankpin bearing cap and connecting rod.
 Install the crankpin bearing inserts onto the bearing cap and connecting rod, aligning each tab with each groove.

BEARINGS

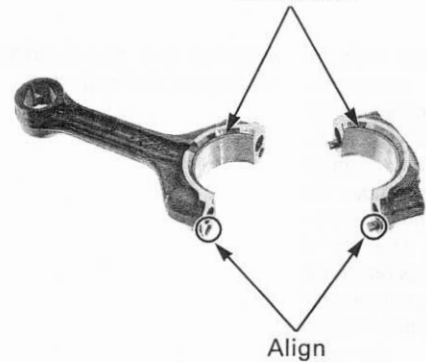

PISTON/CYLINDER

PISTON/CONNECTING ROD REMOVAL

NOTICE

- This motorcycle is equipped with aluminum cylinder sleeves. Before piston removal, place a clean shop towel around the connecting rod to prevent damaging the cylinder sleeve.
- Do not try to remove the piston/connecting rod assembly from bottom of the cylinder; the assembly will get stuck in the gap between the cylinder liner and the upper crankcase.
- Do not interchange the bearing inserts. They must be installed in their original locations or the correct bearing oil clearance may not be obtained, resulting in engine damage.

Mark all parts as you remove them to indicate the correct cylinder for reassembly.

Remove the bolts and crankpin bearing caps.

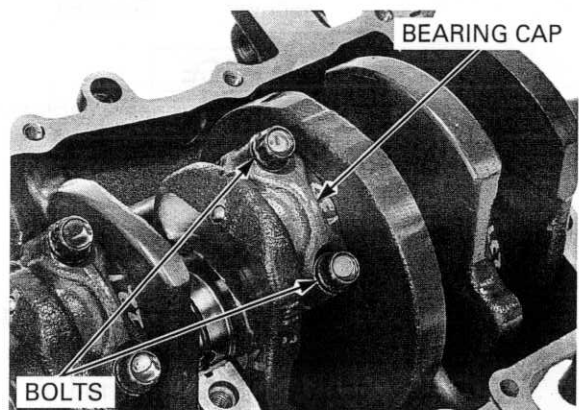

Do not try to remove the connecting rod/piston assembly from the bottom of the cylinder; the assembly will be locked when the oil ring expands in the gap between the cylinder liner and the upper crankcase.

Remove the piston/connecting rod assembly from the top of the cylinder.

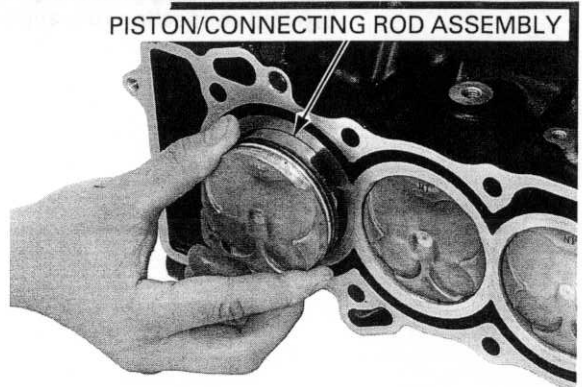

PISTON REMOVAL

Remove the piston pin clip with pliers. Push the piston pin out of the piston and connecting rod, and remove the piston.

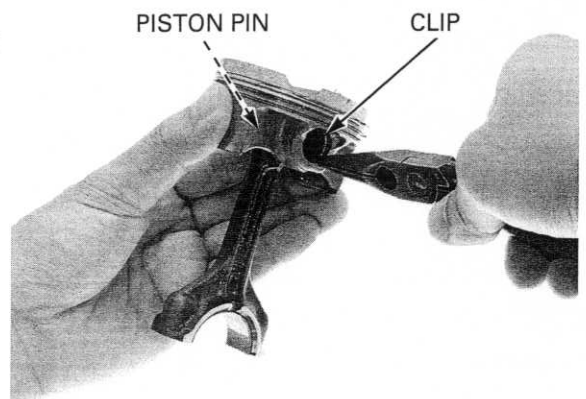

PISTON DISASSEMBLY

Be careful not to damage the piston ring by spreading the ends too far. Spread each piston ring ends and remove them by lifting up at a point opposite the gap.

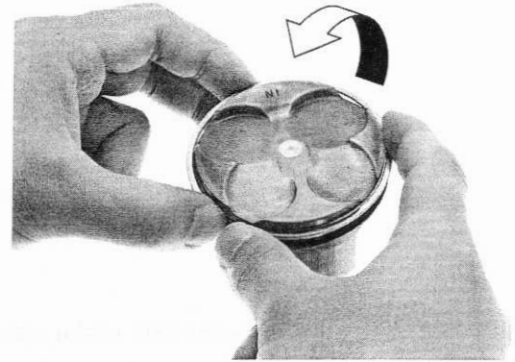

Never use a wire brush; it will scratch the groove. Clean carbon deposits from the piston ring grooves with a ring that will be discarded.

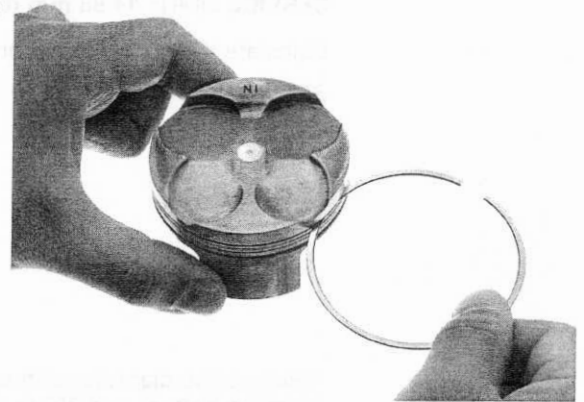

PISTON INSPECTION

Inspect the piston rings for movement by rotating the rings. The rings should be able to move in their grooves without catching.

Push the ring until the outer surface of the piston ring is nearly flush with the piston and measure the ring-to-ring groove clearance.

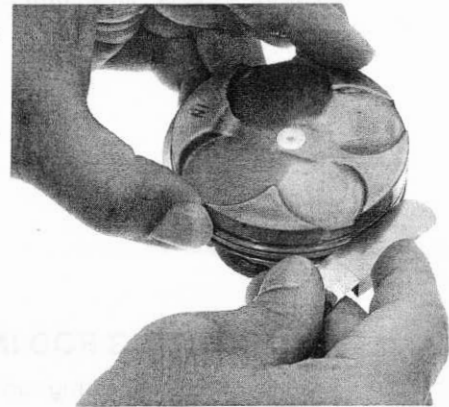

SERVICE LIMITS:

- Top: 0.10 mm (0.004 in)**
- Second: 0.08 mm (0.003 in)**

Push the rings into the cylinder with the top of the piston to be sure they are squarely in the cylinder. Insert the piston ring squarely into the top of the cylinder and measure the ring end gap.

SERVICE LIMITS:

- Top: 0.4 mm (0.02 in)**
- Second: 0.5 mm (0.02 in)**
- Oil (side rail): 1.0 mm (0.04 in)**

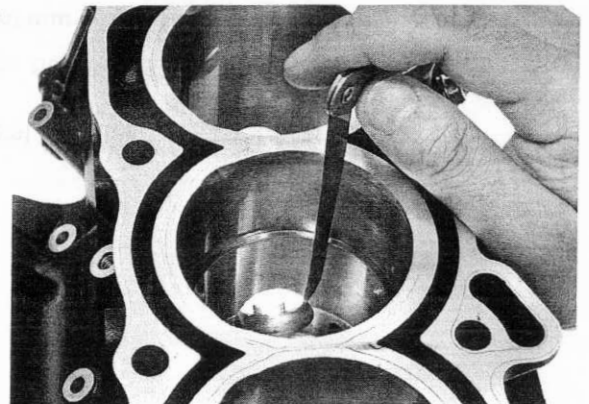

CRANKSHAFT/PISTON/CYLINDER

Measure the piston pin bore I.D.

SERVICE LIMIT: 15.07 mm (0.593 in)

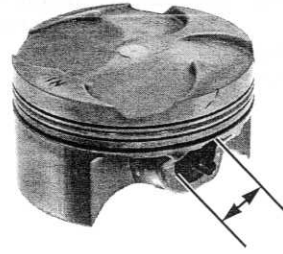

Measure the O.D. of the piston pin.

SERVICE LIMIT: 14.98 mm (0.590 in)

Calculate the piston-to-piston pin clearance.

SERVICE LIMIT: 0.09 mm (0.004 in)

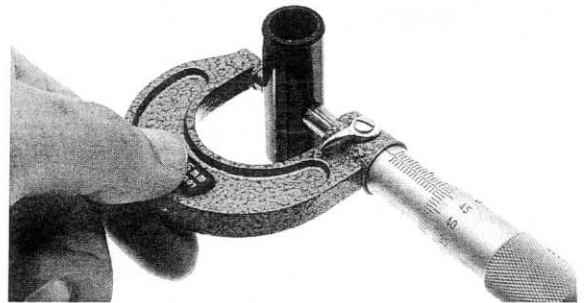

Measure the diameter of the piston at 6 mm (0.2 in) from the bottom and 90° to the piston pin hole.

SERVICE LIMIT: 66.90 mm (2.634 in)

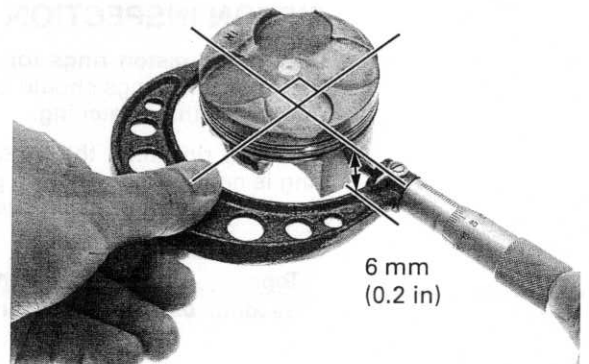

CONNECTING ROD INSPECTION

Measure the connecting rod small end I.D.

SERVICE LIMIT: 15.05 mm (0.593 in)

Calculate the connecting rod-to-piston pin clearance.

SERVICE LIMIT: 0.07 mm (0.003 in)

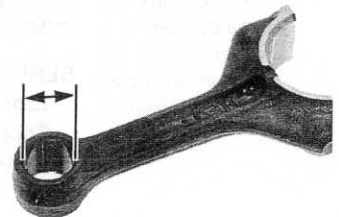

CYLINDER INSPECTION

Inspect the cylinder bore for wear or damage.
 Measure the cylinder I.D. in X and Y axis at three levels.
 Take the maximum reading to determine the cylinder wear.

SERVICE LIMIT: 67.10 mm (2.642 in)

Calculate the cylinder to piston clearance.
 Take a maximum reading to determine the clearance.
 For piston O.D. measurement (page 13-16).

SERVICE LIMIT: 0.10 mm (0.004 in)

Calculate the taper and out-of-round at three levels in X and Y axis. Take the maximum reading to determine them.

SERVICE LIMITS:

Taper: 0.10 mm (0.004 in)

Out-of-round: 0.10 mm (0.004 in)

The cylinder must be rebored and an oversize piston fitted if the service limits are exceeded.

**The following oversize piston is available:
 0.25 mm (0.010 in)**

The cylinder to piston clearance for the oversize piston must be: 0.015 – 0.050 mm (0.0006 – 0.0020 in).

Inspect the top of the cylinder for warpage.

SERVICE LIMIT: 0.10 mm (0.004 in)

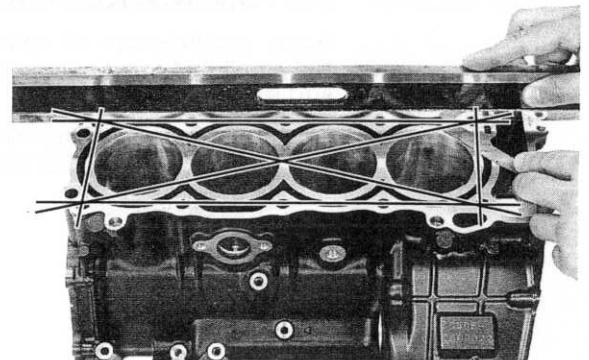
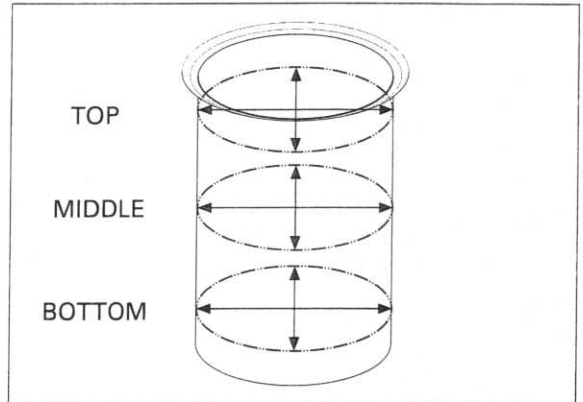
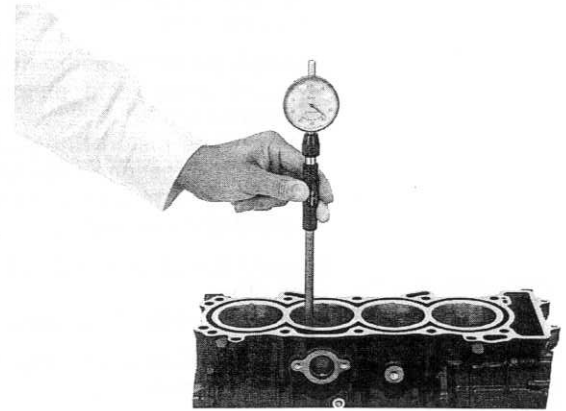

CRANKSHAFT/PISTON/CYLINDER

PISTON ASSEMBLY

Clean the piston ring grooves thoroughly and install the piston rings.

- Apply oil to the piston rings.
- Avoid piston and piston ring damage during installation.
- Install the piston rings with the marking (R: top ring, RNE: second ring) facing up.
- To install the oil ring, install the spacer first, then install the side rails.

Stagger the piston ring end gaps 120° apart from each other.

Stagger the side rail end gaps as shown.

After installation, the rings should rotate freely in the ring groove.

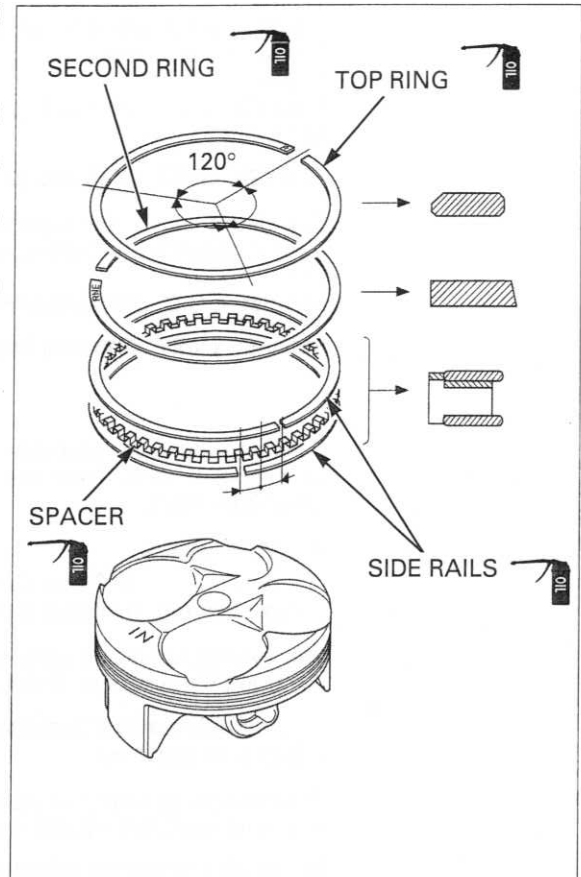

PISTON INSTALLATION

Apply molybdenum oil solution to the connecting rod small end inner surfaces and piston pin sliding surfaces.

Assemble the piston and connecting rod with the journal bearing tab facing to the piston "IN" mark.

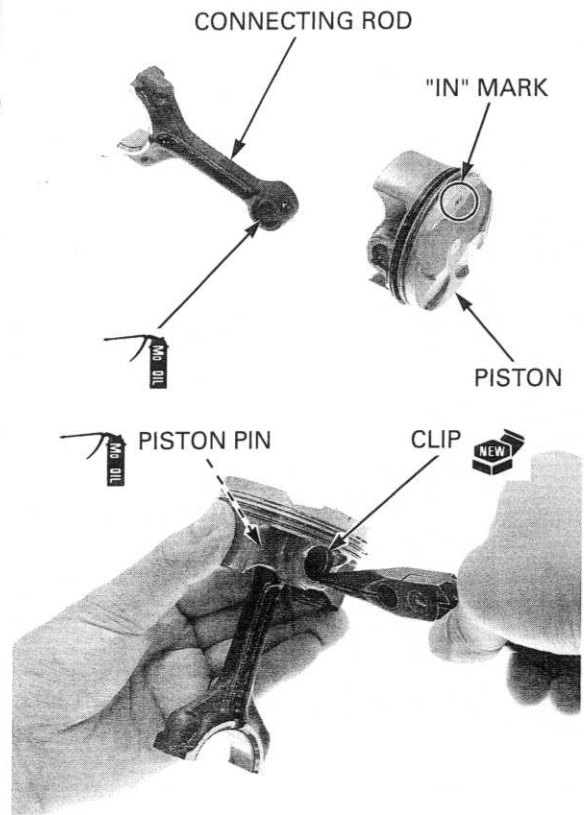

Apply molybdenum oil solution to the piston pin sliding surface.

Install the piston pin and secure it using new piston pin clips.

- Make sure that the piston pin clips are seated securely.
- Do not align the piston pin clip end gap with the piston cut-out.

Coat the cylinder walls, pistons and piston rings with engine oil.

Install the piston/ connecting rod assembly with the piston "IN" mark facing the intake side.

Install the piston/connecting rod assemblies into the cylinders using a commercially available piston ring compressor tool.

When reusing the connecting rods, they must be installed in their original locations.

NOTICE

- While installing the piston, be careful not to damage the top surface of the cylinder, especially around the cylinder bore.
- Be careful not to damage the cylinder sleeve and crankpin with the connecting rod.

Make sure the piston ring compressor tool sits flush on the top surface of the cylinder.

Use the handle of a plastic hammer or equivalent tool to tap the piston into the cylinder.

Install the crankshaft (page 13-6).

Apply molybdenum oil solution to the crankpin bearing sliding surface on the bearing caps.

Install the crankpin bearing caps, aligning the dowel pins with the holes in the connecting rods.

PLASTIC REGION TIGHTENING METHOD:

The crankpin bearing cap bolts cannot be reused. Once the bolts have been loosened replace them with new ones.

Apply oil to new crankpin bearing cap bolt threads and seating surfaces, and install the bolts.

Tighten the bolts in two or three steps alternately.

Further tighten the bolts 90°.

TORQUE: 20 N·m (2.0 kgf·m, 15 lbf·ft) + 90°

Assemble the crankcase halves (page 12-16).

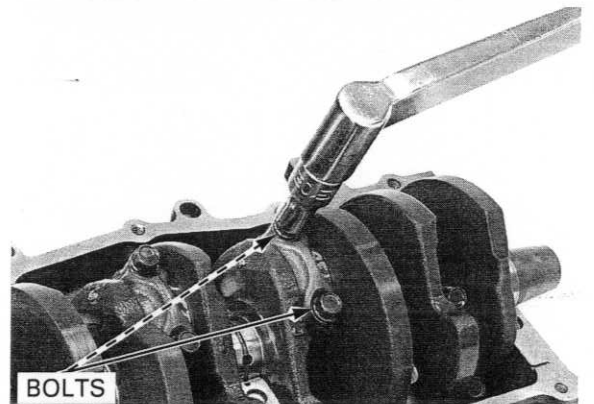
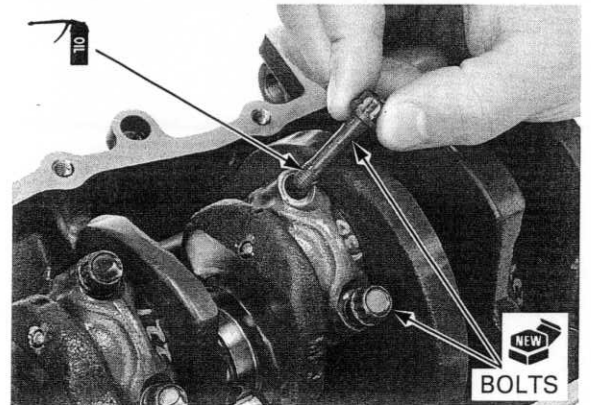
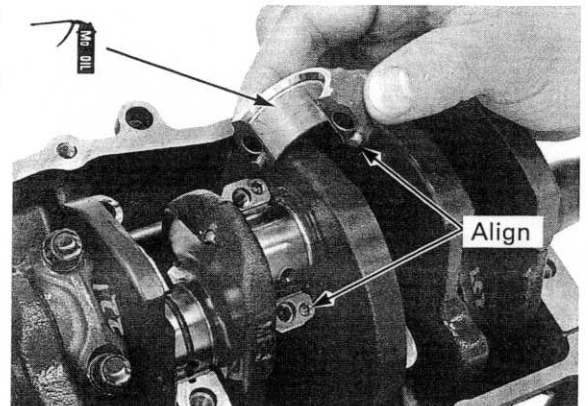
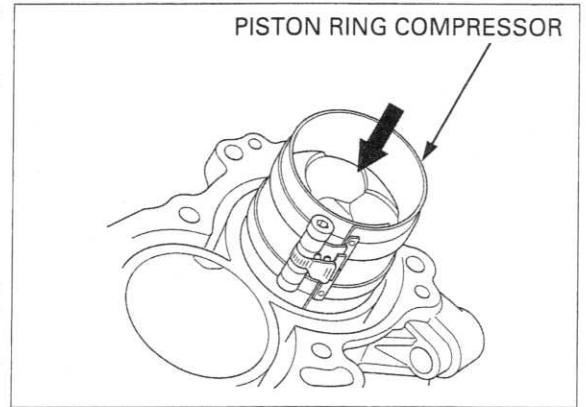

MEMO

MEMORANDUM FOR THE RECORD

DATE: 10/10/51

TO: SAC, NEW YORK

FROM: SAC, NEW YORK

SUBJECT: [REDACTED]

[REDACTED]

[REDACTED]

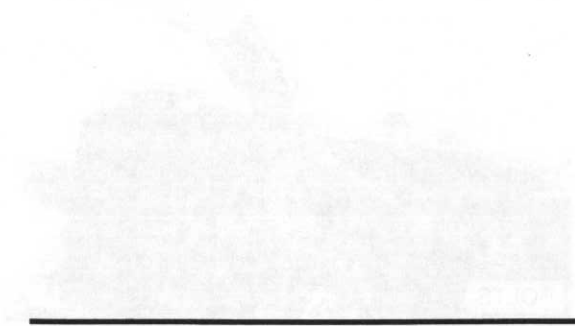
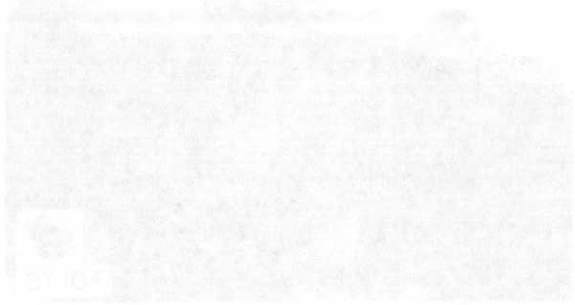
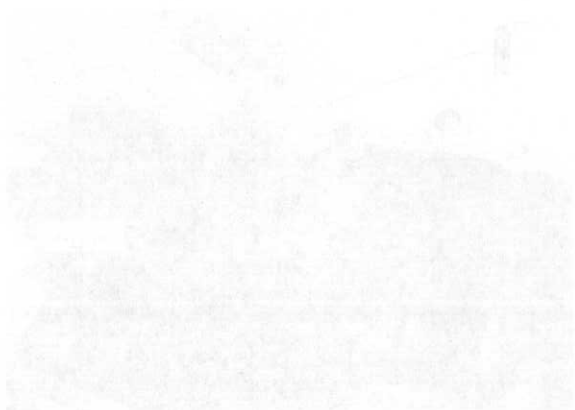

14. FRONT WHEEL/SUSPENSION/STEERING

COMPONENT LOCATION	14-2	FRONT WHEEL	14-16
SERVICE INFORMATION	14-3	FORK	14-22
TROUBLESHOOTING	14-7	HESD	14-33
HESD TROUBLESHOOTING	14-8	STEERING STEM.....	14-34
HANDLEBARS.....	14-10		

FRONT WHEEL/SUSPENSION/STEERING

COMPONENT LOCATION

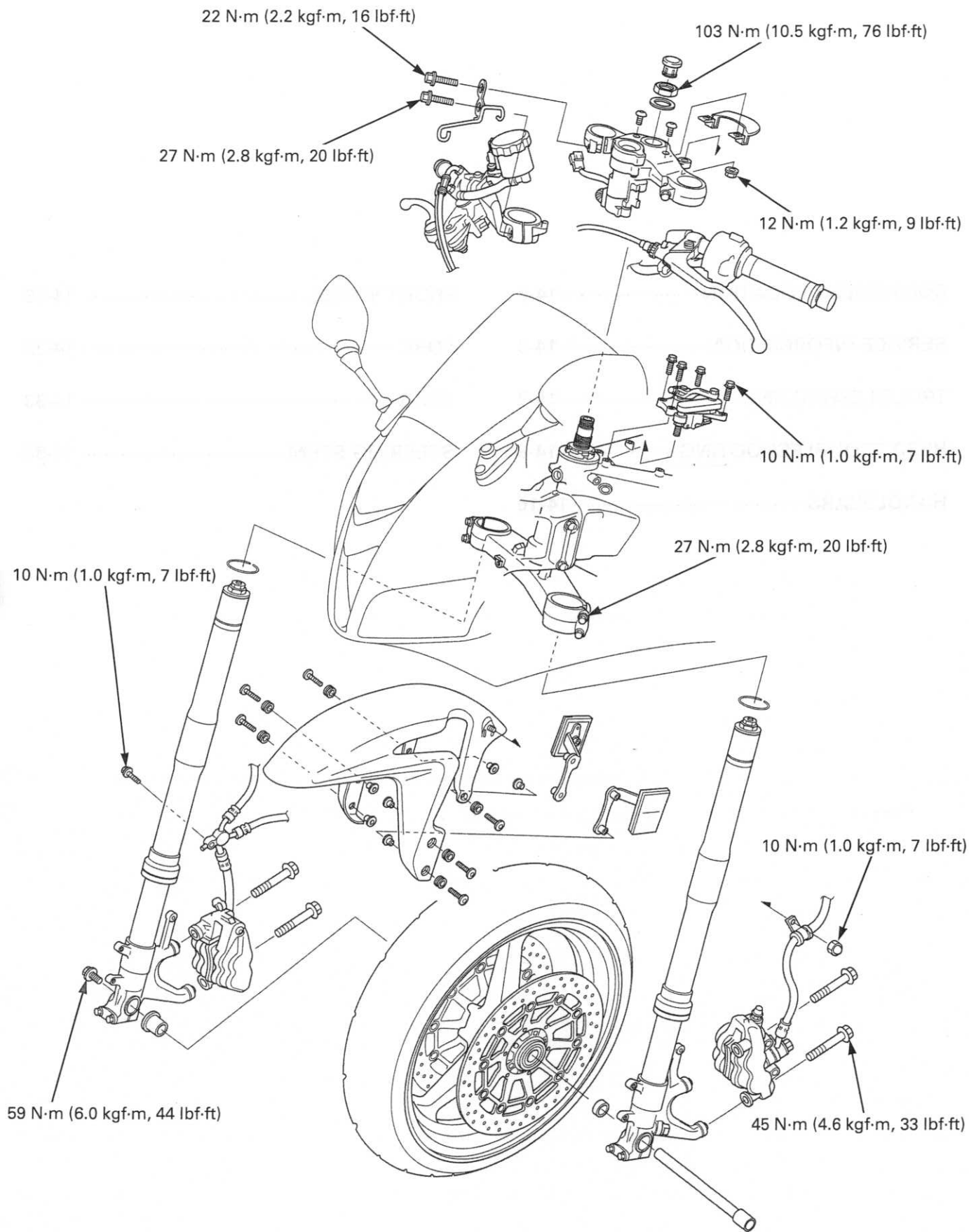

SERVICE INFORMATION

GENERAL

- When servicing the front wheel, fork or steering stem, support the motorcycle using a safety stand or hoist.
- A contaminated brake disc or pad reduces stopping power. Discard contaminated pads and clean a contaminated disc with a high quality brake degreasing agent.
- After the front wheel installation, check the brake operation by applying the brake lever.
- For brake system information (page 16-4).
- Use only tires marked "TUBELESS" and tubeless valves on rim marked "TUBELESS TIRE APPLICABLE".

SPECIFICATIONS

Unit: mm (in)



ITEM		STANDARD	SERVICE LIMIT
Minimum tire tread depth		-	1.5 (0.06)
Cold tire pressure	Driver only	250 kPa (2.50 kgf/cm ² , 36 psi)	-
	Driver and passenger	250 kPa (2.50 kgf/cm ² , 36 psi)	-
Axle runout		-	0.2 (0.01)
Wheel rim runout	Radial	-	2.0 (0.08)
	Axial	-	2.0 (0.08)
Wheel balance weight		-	60 g (2.1 oz) max.
Fork	Spring free length	243.4 (9.58)	238.5 (9.39)
	Tube runout	-	0.20 (0.008)
	Recommended fork fluid	Pro Honda Suspension Fluid SS-47 (10 W)	-
	Fluid level	93 (3.7)	-
	Fluid capacity	413 ± 2.5 cm ³ (14.0 ± 0.08 US oz, 14.5 ± 0.09 Imp oz)	-
	Pre-load adjuster initial setting	5 turns from minimum	-
	Rebound damping adjuster initial setting	2-1/2 turns out from full hard	-
	Compression damping adjuster initial setting	2 turns out from full hard	-
Steering head bearing pre-load		14.7 – 17.7 N (1.5 – 1.8 kgf)	-

TORQUE VALUES



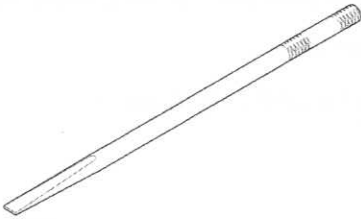
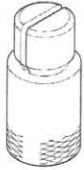
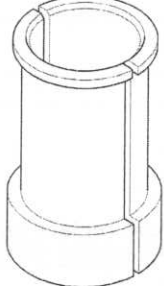
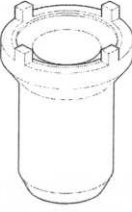

Handlebar weight mounting screw	9.8 N·m (1.0 kgf·m, 7 lbf·ft)	ALOC screw; replace with a new one
Front brake disc bolt	20 N·m (2.0 kgf·m, 15 lbf·ft)	ALOC bolt; replace with a new one
Front axle bolt	59 N·m (6.0 kgf·m, 44 lbf·ft)	
Front axle holder bolt	22 N·m (2.2 kgf·m, 16 lbf·ft)	
Fork socket bolt	34 N·m (3.5 kgf·m, 25 lbf·ft)	Apply locking agent to the threads
Fork bolt	34 N·m (3.5 kgf·m, 25 lbf·ft)	
Handlebar pinch bolt	27 N·m (2.8 kgf·m, 20 lbf·ft)	
Top bridge pinch bolt	22 N·m (2.2 kgf·m, 16 lbf·ft)	
Bottom bridge pinch bolt	27 N·m (2.8 kgf·m, 20 lbf·ft)	
Steering stem adjusting nut	-	See page 14-41
Steering stem adjusting lock nut	-	See page 14-41
Steering stem nut	103 N·m (10.5 kgf·m, 76 lbf·ft)	
Front brake hose clamp bolt	9.0 N·m (0.9 kgf·m, 6.6 lbf·ft)	
Front brake hose clamp nut	10 N·m (1.0 kgf·m, 7 lbf·ft)	
Front brake hose 3-way joint bolt	10 N·m (1.0 kgf·m, 7 lbf·ft)	
Front master cylinder holder bolt	12 N·m (1.2 kgf·m, 9 lbf·ft)	
Front brake caliper mounting bolt	45 N·m (4.6 kgf·m, 33 lbf·ft)	ALOC bolt; replace with a new one
Second arm nut	12 N·m (1.2 kgf·m, 9 lbf·ft)	
Compression adjuster plug bolt	17 N·m (1.7 kgf·m, 13 lbf·ft)	
Steering damper mounting bolt	10 N·m (1.0 kgf·m, 7 lbf·ft)	
Right handlebar switch housing screw	0.9 N·m (0.09 kgf·m, 0.7 lbf·ft)	
Fork damper rod lock nut	20 N·m (2.0 kgf·m, 15 lbf·ft)	

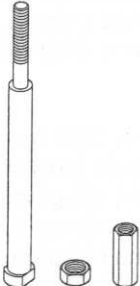
FRONT WHEEL/SUSPENSION/STEERING

TOOLS

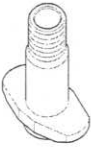
<p>Bearing remover shaft 07GGD-0010100</p> 	<p>Bearing remover head, 20 mm 07746-0050600</p> 	<p>Driver 07749-0010000</p> 
<p>Attachment, 42 x 47 mm 07746-0010300</p> 	<p>Pilot, 20 mm 07746-0040500</p> 	<p>Fork seal driver 07KMD-KZ30100</p>  <p>or 07NMD-KZ3010A (U.S.A. only)</p>
<p>Fork seal driver attachment 07RMD-MW40100</p> 	<p>Steering stem socket 07916-3710101</p>  <p>or 07916-3710100 (U.S.A. only)</p>	<p>Driver attachment (upper) 070MF-MCJ0100</p>  <p>Not available in U.S.A.</p>
<p>Driver attachment (lower) 070MF-MCJ0200</p>  <p>Not available in U.S.A.</p>	<p>Driver shaft assembly 07946-KM90301</p>  <p>Not available in U.S.A.</p>	<p>Bearing remover, A 07946-KM90401</p>  <p>Not available in U.S.A.</p>

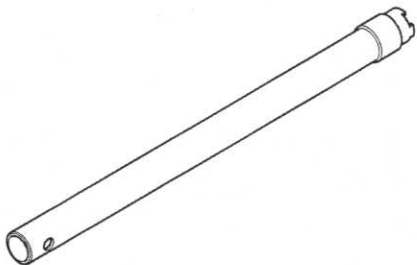
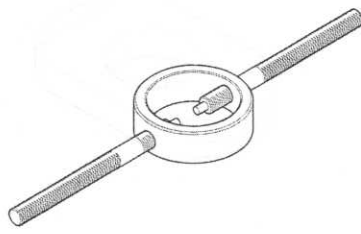
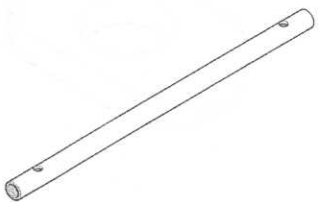
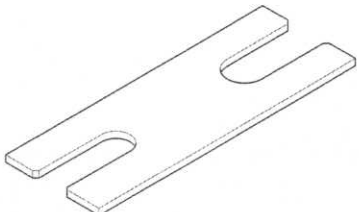
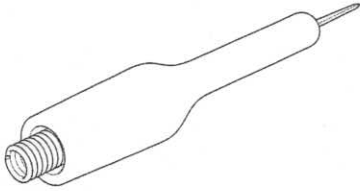
FRONT WHEEL/SUSPENSION/STEERING

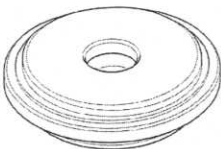
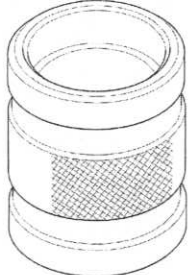
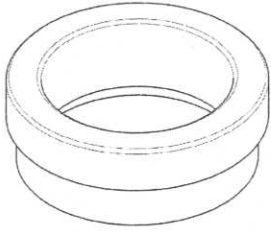
<p>Bearing remover, B 07NMF-MT70110</p>  <p>Not available in U.S.A.</p>	<p>Assembly base 07946-KM90600</p>  <p>Not available in U.S.A.</p>	<p>Attachment, 30 mm I.D. 07746-0030300</p> 
<p>Fork damper holder 07YMB-MCF0101</p>  <p>or 07YMB-MCFA100 (U.S.A. only)</p>	<p>Spring collar holder 070MF-MBZC110</p>  <p>NOTE This tool is a part of fork damper install set (P/N 070MF-MBZC100)</p>	<p>Damper rod holder 070MF-MBZC120</p>  <p>NOTE This tool is a part of fork damper install set (P/N 070MF-MBZC100)</p>
<p>Stopper plate 070MF-MBZC130</p>  <p>NOTE This tool is a part of fork damper install set (P/N 070MF-MBZC100)</p>	<p>Test probe 07ZAJ-RDJA110</p> 	<p>HDS pocket tester TDS 3557-0112-01 (U.S.A. only)</p> 
<p>Main bearing driver attachment 07946-ME90200</p> 	<p>Fork seal driver weight 07947-KA50100</p> 	<p>Oil seal driver 07965-MA60000</p> 

FRONT WHEEL/SUSPENSION/STEERING

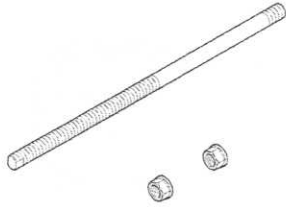
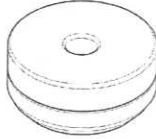
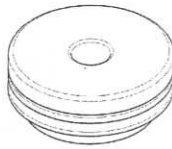
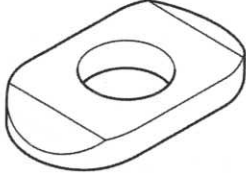
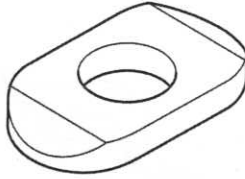
<p>Installer shaft 07VMF-KZ30200</p> 	<p>Installer attachment A 07VMF-MAT0100</p> 	<p>Installer attachment B 07VMF-MAT0200</p> 
<p>Remover attachment C 07AMF-MEEA100</p> 	<p>Remover attachment D 07AMF-MEEA200</p> 	

TROUBLESHOOTING

NOTE:

If there is any problem at steering, remove the HESD (page 14-33) and inspect the steering condition. Check the HESD by using the Function Test (page 14-8) in case of no faulty parts at steering.

Hard steering

- Faulty HESD
- Steering stem adjusting nut too tight
- Worn or damaged steering head bearings
- Bent steering stem
- Insufficient tire pressure

Steers to one side or does not track straight

- Faulty HESD
- Damaged or loose steering head bearings
- Bent forks
- Bent axle
- Bent frame
- Worn or damaged wheel bearings
- Worn or damaged swingarm pivot bearings

Front wheel wobbling

- Bent rim
- Worn or damaged front wheel bearings
- Faulty tire
- Unbalanced front tire and wheel

Front wheel turns hard

- Faulty front wheel bearings
- Bent front axle
- Front brake drag

Soft suspension

- Insufficient fluid in fork
- Incorrect fork fluid weight
- Weak fork springs
- Insufficient tire pressure

Stiff suspension

- Bent fork tubes
- Too much fluid in fork
- Incorrect fork fluid weight
- Clogged fork fluid passage

Front suspension noise

- Insufficient fluid in fork
- Loose fork fasteners

HESD TROUBLESHOOTING

- The HESD system is equipped with a Self-Diagnostic System that is linked to the PGM-FI system (page 6-13). If the MIL blinks, follow the Self-Diagnostic Procedures to remedy the problem (Refer to DTC troubleshooting: page 6-18). The HESD system is also equipped with a Function Test Mode to check the HESD under maximum damping characteristics. If there is any abnormal condition in the HESD system without MIL blinking, follow the HESD function test and check the HESD function.
- The HESD system includes a fail-safe function to secure a minimum running capability even when there is any trouble in the system. When any abnormality is detected by the self-diagnosis function, the ECM stops the HESD system control by shutting off the current supply to the linear solenoid and the HESD will operate under minimum damping characteristics accordingly.
- For PGM-FI system diagram (page 6-9).
- For HDS pocket tester information (page 6-14).
- For DTC readout (page 6-14).
- For DTC index (page 6-16).
- A faulty HESD system is often related to poorly connected or corroded connectors. Check those connections before proceeding.

HESD FUNCTION TEST

NOTE:

- The HESD system is also equipped with a Function Test Mode so that a technician can compare the minimum with maximum damping characteristics without riding. The HESD system is set to minimum damping at no vehicle speed under normal conditions. By using the Function Test Mode, the ECM operates the linear solenoid with maximum current so the HESD system is temporarily set to maximum damping.
- It is not possible to use the HESD Function Test Mode when any problem occur.
- Before performing the HESD function test, remove the HESD (page 14-33) and check the following.
 - Steering head bearing pre-load (page 14-44)
 - Wear or damage of steering head bearings (page 4-36)
 - HESD-to-steering linkage

HESD FUNCTION TEST PROCEDURE

- Support the motorcycle using a hoist or equivalent and raise the front wheel off the ground.
- Before function test, check the feel for minimum damping characteristics with moving the steering right and left quickly several times. Operate the steering quickly and at a uniform force any time of the test.

Perform the HESD function test as follows:

1. Lower the sidestand (sidestand switch OFF).
2. Shift the transmission into any gear other than neutral.
3. Open the throttle grip fully.
4. Turn the ignition switch ON while keeping the state of 1 – 3.

The HESD indicator starts blinking and the HESD system enters the Function Test Mode for 10 seconds.

Make sure that the damping characteristics (force) changes, by means of comparing the minimum damping characteristics before Function Test with the maximum damping characteristics under the Function Test.

If the HESD damping characteristics (force) in Function Test Mode does not change at all, replace the HESD unit with a new one (page 14-33).

DTC TROUBLESHOOTING

DTC	Causes	Symptoms	Refer to
11-1	<ul style="list-style-type: none"> Loose or poor contact on VS sensor connector VS sensor or its circuit malfunction 	<ul style="list-style-type: none"> Engine operates normally HESD does not function <ul style="list-style-type: none"> ECM does not control the linear solenoid Minimum damping characteristics 	6-28
51-1	<ul style="list-style-type: none"> Loose or poor contact of the HESD solenoid connector HESD solenoid or its circuit malfunction 	<ul style="list-style-type: none"> Engine operates normally HESD does not function <ul style="list-style-type: none"> ECM does not control the linear solenoid Minimum damping characteristics 	14-9

DTC 51-1 (LINEAR SOLENOID)

Before starting the inspection, check for loose or poor contact on the linear solenoid connector and recheck the DTC.

1. Linear Solenoid Circuit Inspection

Turn the ignition switch OFF.
 Disconnect the ECM 33P (Gray) connector.
 Measure the resistance at the ECM 33P (Gray) connector terminals of the wire side.

Connection: B8 – B10

TOOL:

Test probe 07ZAJ-RDJA110

Is the resistance within 10 – 15 Ω (20°C/68°F)?

YES – GO TO STEP 3.

NO – GO TO STEP 2.

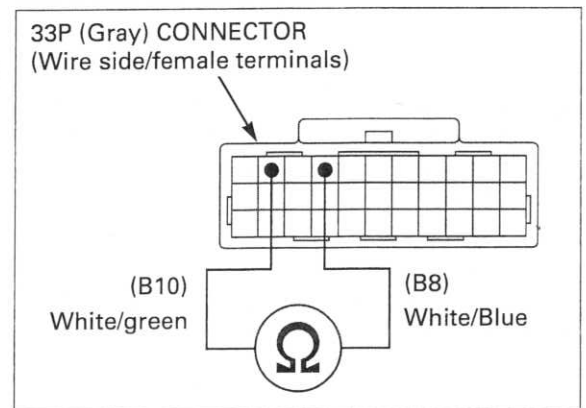

2. Linear Solenoid Resistance Inspection

Remove the HESD (page 14-33).
 Measure the resistance at the linear solenoid terminals.

Is the resistance within 10 – 15 Ω (20°C/68°F)?

YES – Open circuit in White/green or White/Blue wire

NO – Faulty linear solenoid

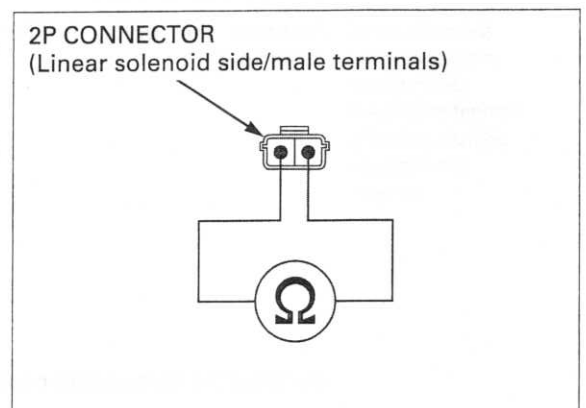

FRONT WHEEL/SUSPENSION/STEERING

3. Linear Solenoid Short Circuit Inspection

Check for continuity between the ECM 33P (Gray) connector terminals at the wire side and ground.

Connection: B8 – body ground
B10 – body ground

TOOL:

Test probe 07ZAJ-RDJA110

Is there continuity?

YES – Short circuit in White/green or White/blue wire

NO – Replace the ECM with a known good one, and recheck

33P (Gray) CONNECTOR
(Wire side/female terminals)

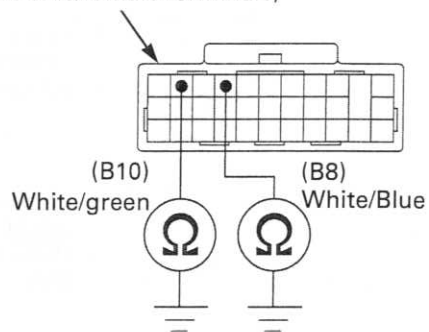

HANDLEBARS

REMOVAL

Remove the screw and right handlebar weight.

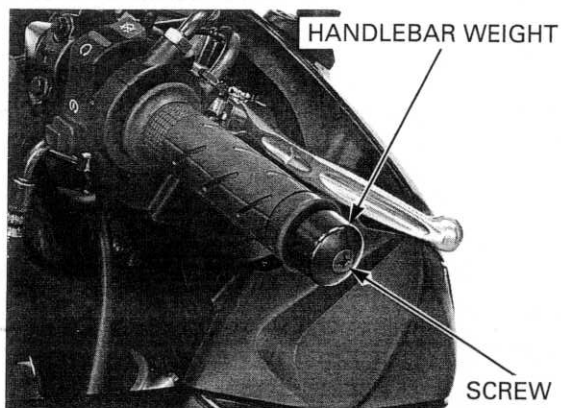

Disconnect the front brake light switch wire connectors from the switch.

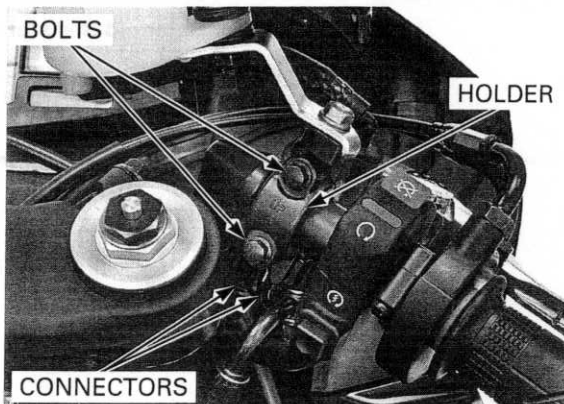

Keep the brake master cylinder reserve tank upright to prevent air from entering the hydraulic system.

Remove the bolts, holder and master cylinder assembly.

Remove the screws and right handlebar switch.

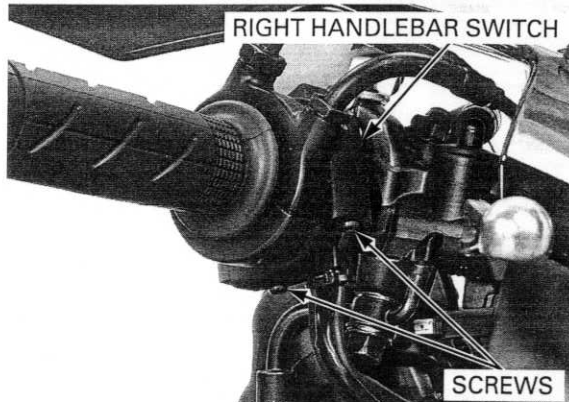

FRONT WHEEL/SUSPENSION/STEERING

Remove the screws and separate the throttle housing.

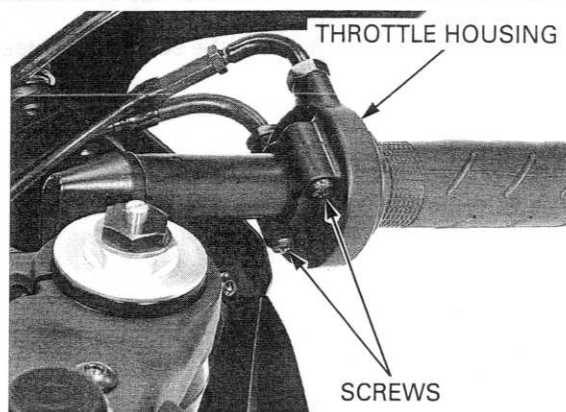

Remove the screw, left handlebar weight and grip from the handlebar.

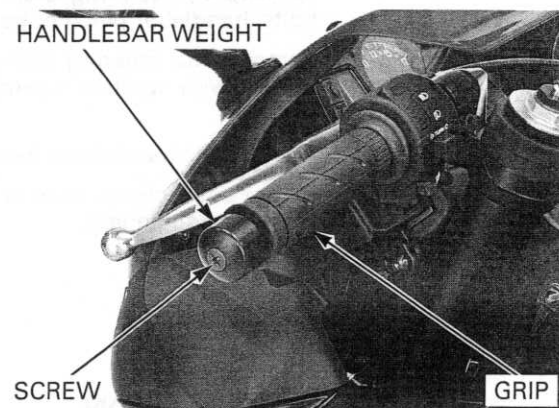

Remove the screws and left handlebar switch housing.

Disconnect the clutch switch connectors from the clutch switch.

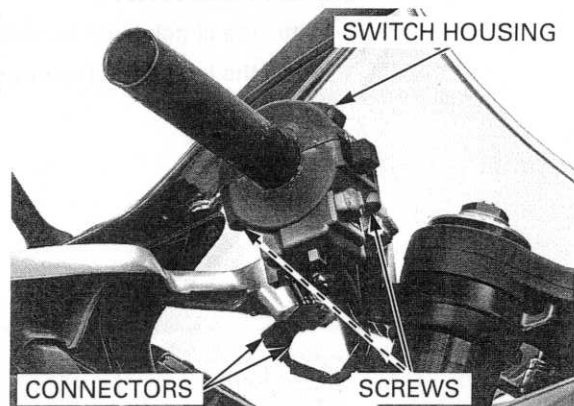

Loosen the clutch lever bracket pinch bolt.

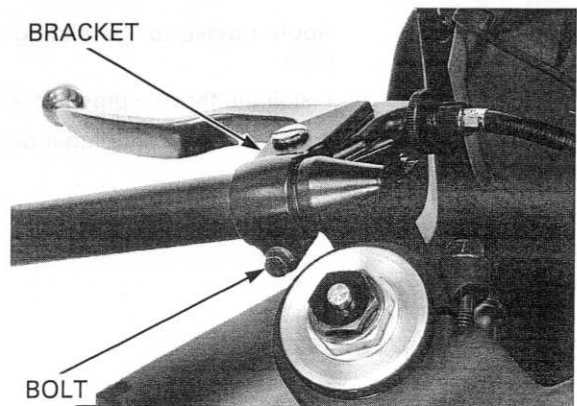

FRONT WHEEL/SUSPENSION/STEERING

Remove the nut and disconnect the second arm from the top bridge.
Remove the screws and steering damper cover.

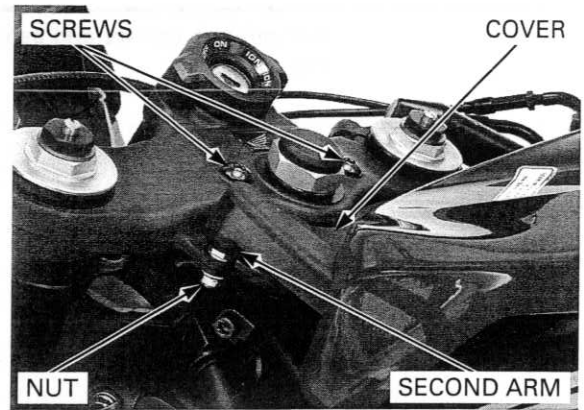

Remove the steering stem cap, top bridge pinch bolts, handlebar pinch bolts and cable guide.

Remove the steering stem nut, washer and top bridge with ignition switch wire connector connected.

Remove the handlebars from the fork sliders.

Remove the clutch lever bracket and throttle pipe from the handlebars.

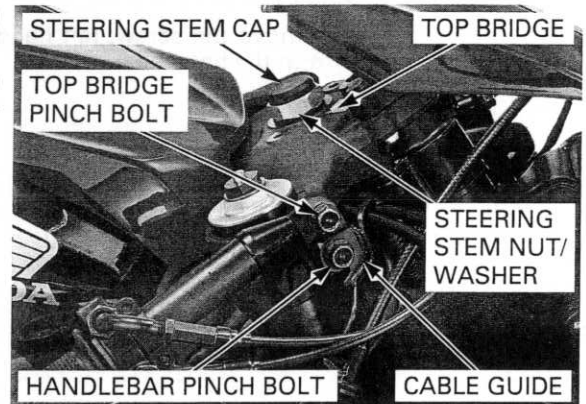

INSTALLATION

Install the clutch lever bracket to the left handlebar.

Install the left handlebar onto the fork slider.

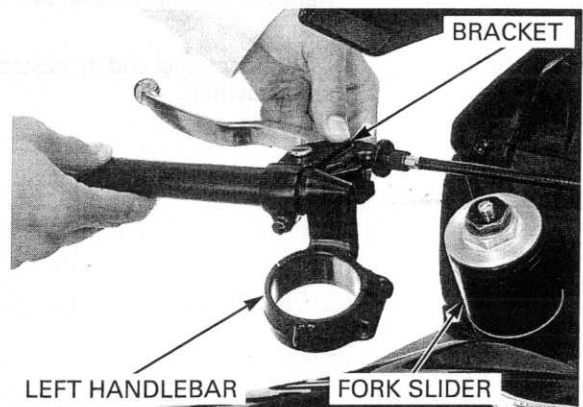

Apply grease to the sliding surface of the throttle pipe.

Install the throttle pipe to the right handlebar.

Install the right handlebar onto the fork slider.

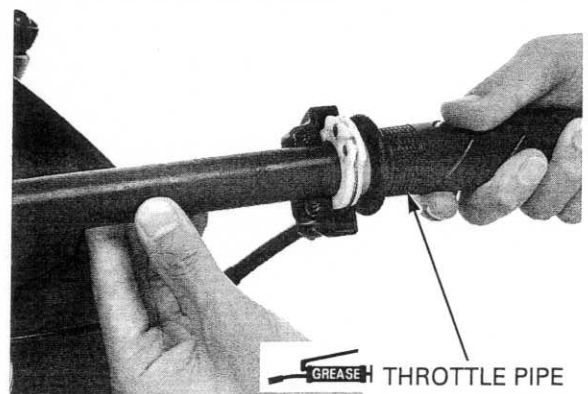

FRONT WHEEL/SUSPENSION/STEERING

Install the top bridge while aligning its holes with the handlebar stopper pins.

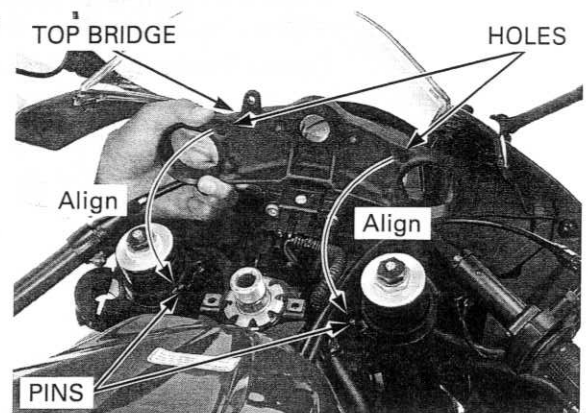

Install the washer and steering stem nut.
Tighten the steering stem nut to the specified torque.

TORQUE: 103 N·m (10.5 kgf·m, 76 lbf·ft)

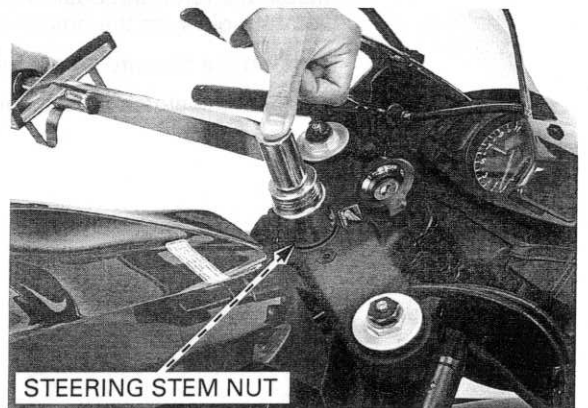

Install the steering stem cap.

Install the cable guide top bridge pinch bolts and handlebar pinch bolts.

Tighten the top bridge pinch bolts to the specified torque.

TORQUE: 22 N·m (2.2 kgf·m, 16 lbf·ft)

Tighten the handlebar pinch bolts to the specified torque.

TORQUE: 27 N·m (2.8 kgf·m, 20 lbf·ft)

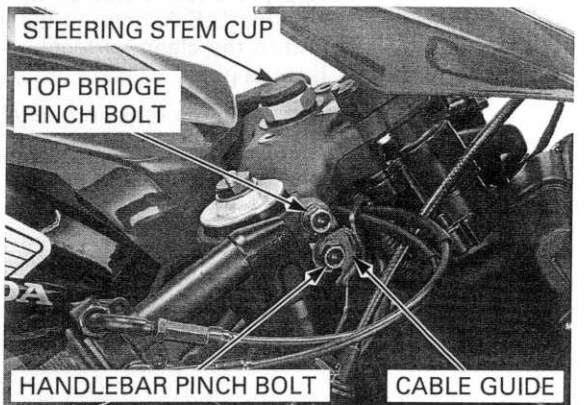

Install the steering damper cover to the top bridge and tighten the screws securely.

Connect the second arm to the top bridge and tighten the nut to the specified torque.

TORQUE: 12 N·m (1.2 kgf·m, 9 lbf·ft)

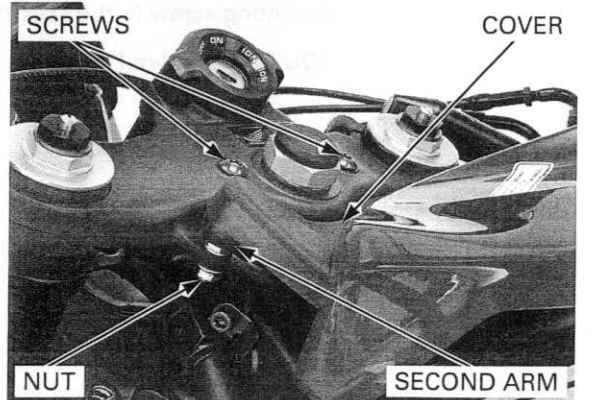

FRONT WHEEL/SUSPENSION/STEERING

Install the clutch lever bracket aligning the punch mark on the left handlebar and clutch lever bracket.
Tighten the clutch lever bracket pinch bolt securely.

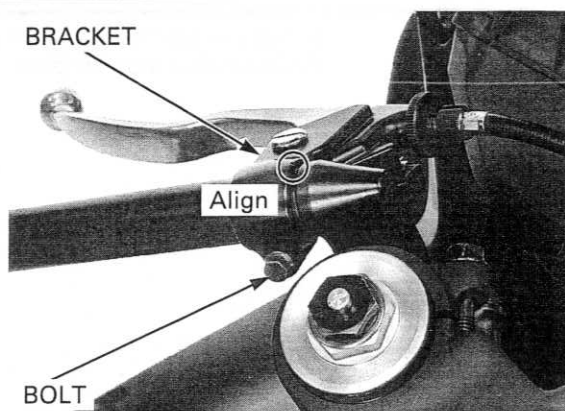

Install the left handlebar switch housing aligning its locating pin with the hole in the handlebar.
Tighten the forward screw first, then the rear screw.
Connect the clutch switch connectors securely.

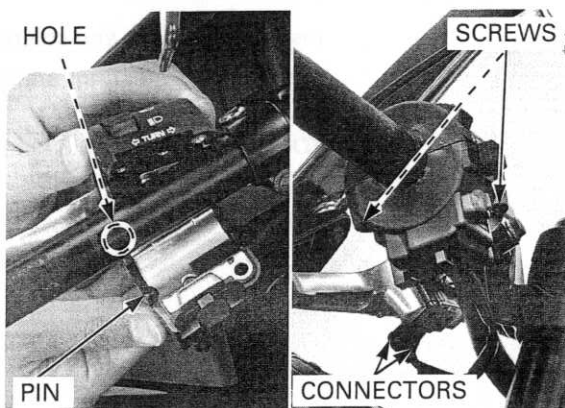

Apply Honda Bond A or Pro Honda hand grip cement (U.S.A. only) to the inner surface of the grip and to the clean surfaces of the left handlebar and throttle pipe.

Wait 3 – 5 minutes and install the grip.

Allow the adhesive to dry for an hour before using.

Rotate the grip for even application of the adhesive.

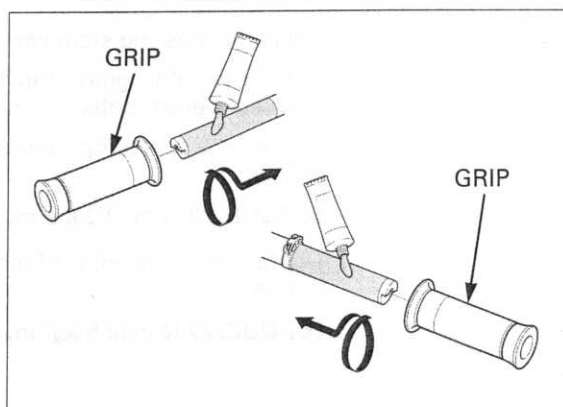

Install the left handlebar weight and tighten a new mounting screw to the specified torque.

TORQUE: 9.8 N·m (1.0 kgf·m, 7 lbf·ft)

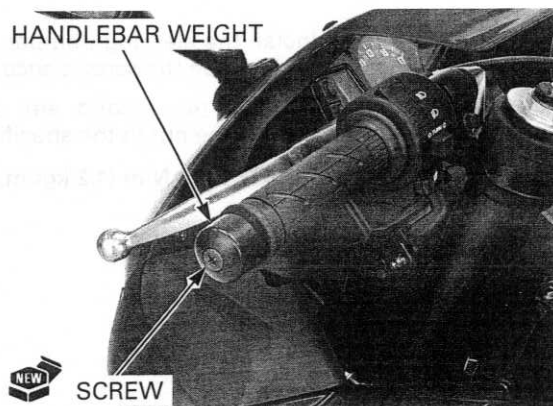

FRONT WHEEL/SUSPENSION/STEERING

Install the throttle housing by aligning its locating pin with the hole on the handlebar.

Tighten the upper screw first, then the lower screw.

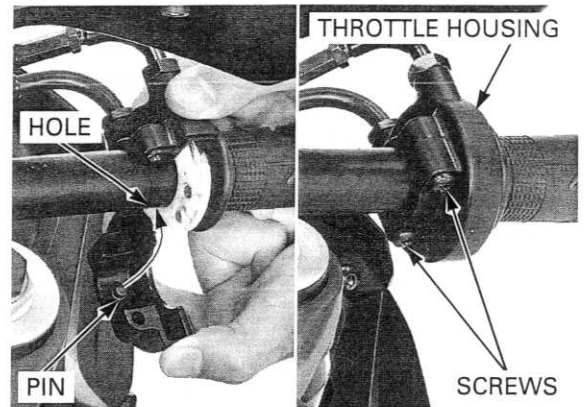

Install the right handlebar switch housing by aligning its locating pin with the hole in the handlebar.

Tighten the forward screw first, then the rear screw to the specified torque.

TORQUE: 0.9 N·m (0.09 kgf·m, 0.7 lbf·ft)

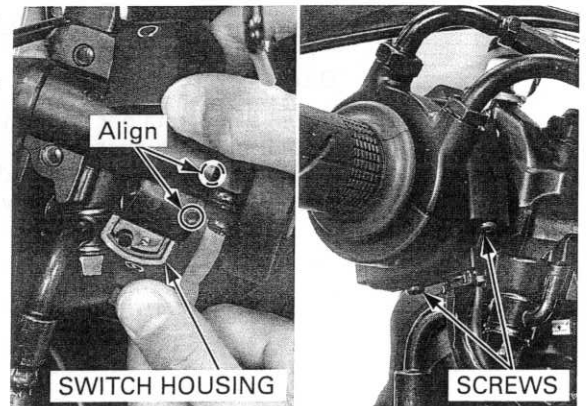

Install the master cylinder by aligning the end of the master cylinder with the punch mark on the handlebar.

Install the master cylinder holder with its "UP" mark facing up.

Tighten the upper bolt first, then the lower bolt.

TORQUE: 12 N·m (1.2 kgf·m, 9 lbf·ft)

Connect the front brake switch wire connectors.

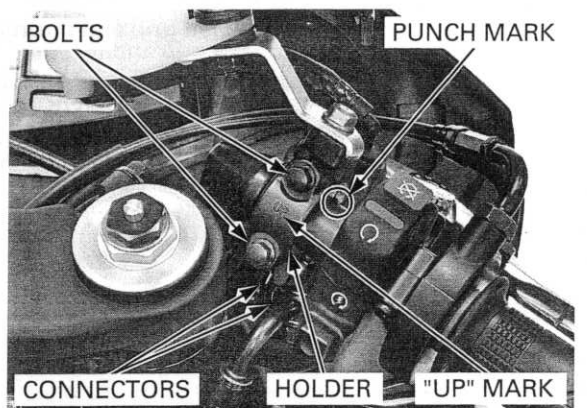

Install the right handlebar weight and tighten a new mounting screw to the specified torque.

TORQUE: 9.8 N·m (1.0 kgf·m, 7 lbf·ft)

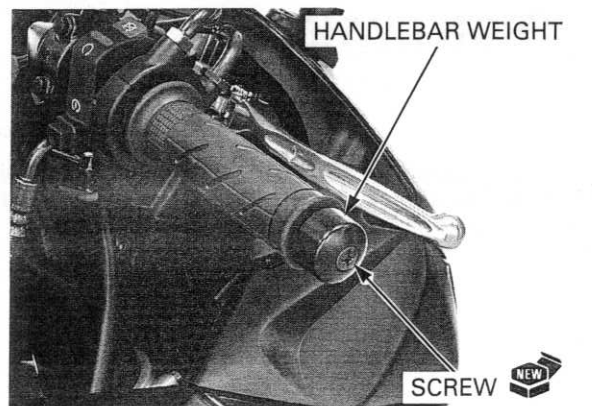

FRONT WHEEL/SUSPENSION/STEERING

HANDLEBAR WEIGHT REPLACEMENT

Remove the left grip and throttle pipe from the handlebar.

Straighten the weight retainer tab by the screwdriver or punch.

Apply lubricant spray through the tab locking hole to the rubber for easy removal.

Temporarily install the handlebar weight and screw, then remove the inner weight by turning the handlebar weight.

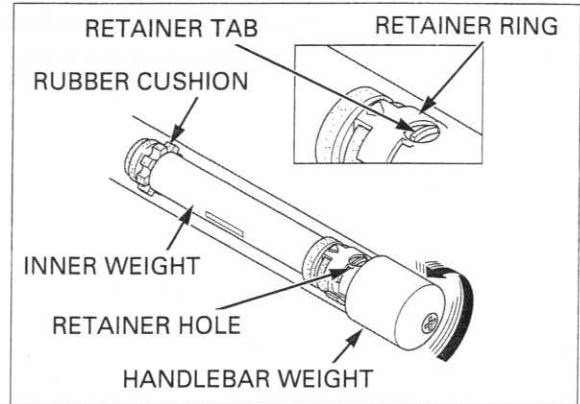

Remove the handlebar weight from the inner weight. Discard the retainer ring.

Install a new retainer ring onto the inner weight. Install the handlebar weight onto the inner weight while aligning the bosses and grooves each other. Install a new mounting screw.

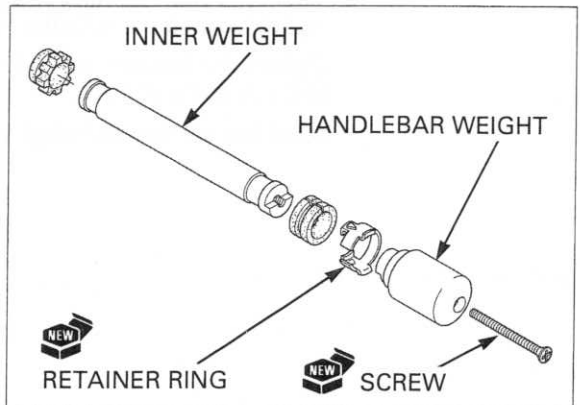

Install the left grip and throttle pipe onto the handlebars.

Insert the handlebar weight assembly into the handlebar.

Turn the handlebar weight and hook the retainer ring tab with the hole in the handlebar.

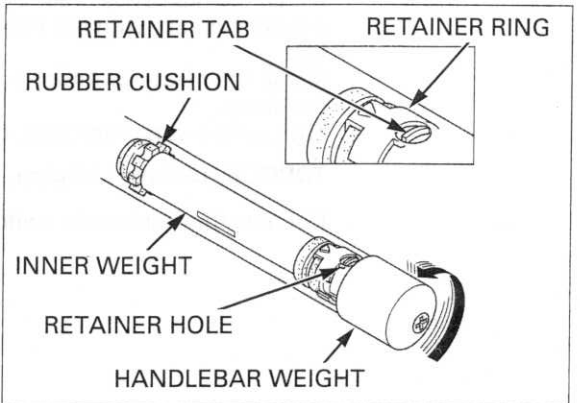

FRONT WHEEL

REMOVAL

Remove the bolts and brake calipers.

Do not operate the brake lever after the brake caliper is removed.

Support the brake caliper with a piece of wire so that it does not hang from the brake hose. Do not twist the brake hose.

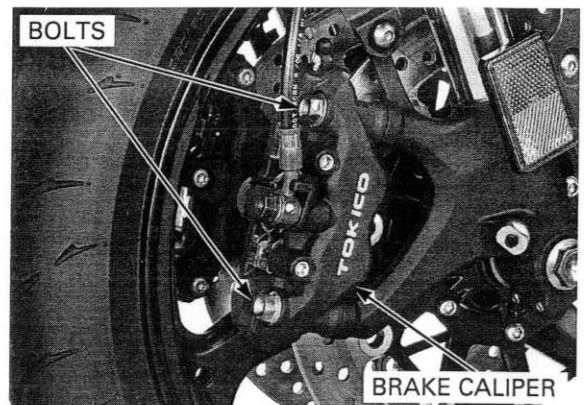

Loosen the right axle holder bolts.
Remove the axle bolt.

Support the motorcycle securely and raise the front wheel off the ground using a safety stand or a hoist.

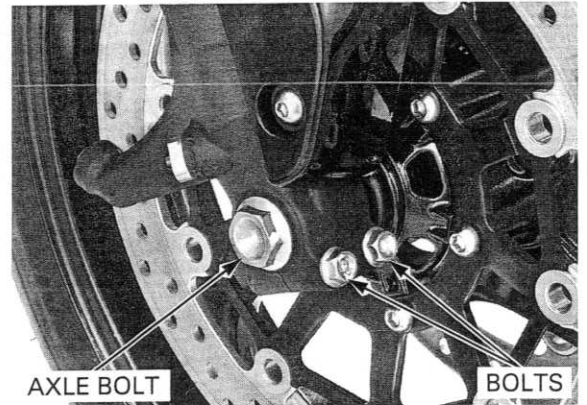

Loosen the left axle holder bolts.
Remove the axle and front wheel.

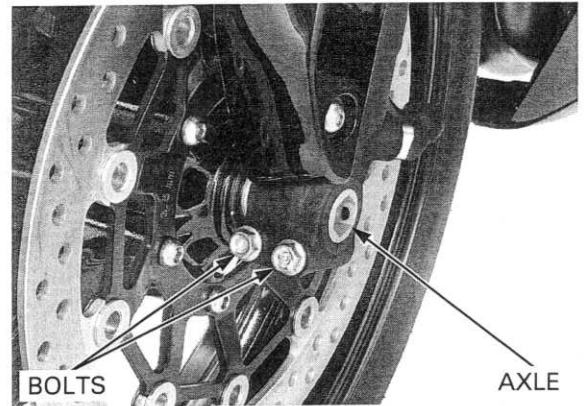

Remove the right and left side collars.

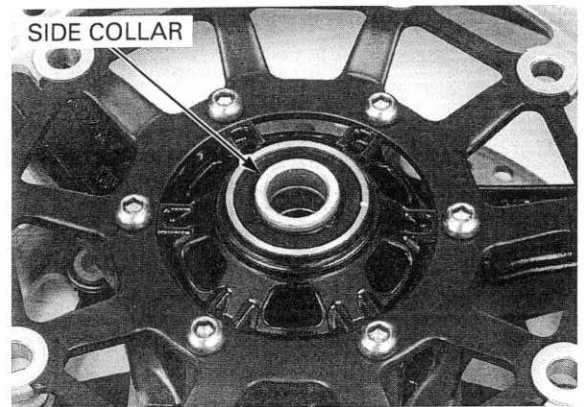

INSPECTION

Axle

Set the axle on V-blocks and measure the runout.
Actual runout is 1/2 the total indicator reading.

SERVICE LIMIT: 0.2 mm (0.01 in)

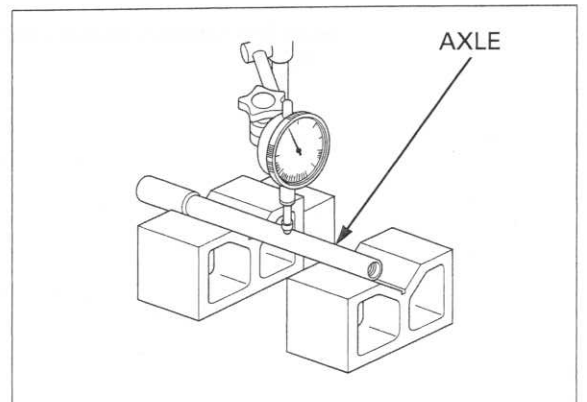

FRONT WHEEL/SUSPENSION/STEERING

Wheel bearing

Turn the inner race of each bearing with your finger. The bearings should turn smoothly and quietly. Also check that the outer race of the bearing fits tightly in the hub.

Replace the bearings in pairs.

Replace the bearings if the inner race do not turn smoothly, quietly, or if the outer race fit loosely in the hub.

Replace the wheel bearings, if necessary (page 14-19).

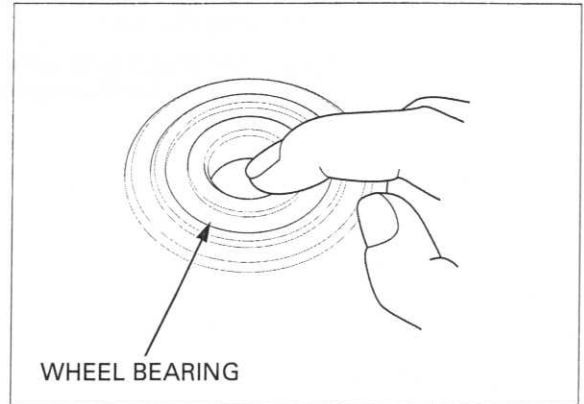

Wheel rim runout

Check the rim runout by placing the wheel in a truing stand.

Spin the wheel by hand, and read the runout using a dial indicator.

Actual runout is 1/2 the total indicator reading.

SERVICE LIMITS:

Radial: 2.0 mm (0.08 in)

Axial: 2.0 mm (0.08 in)

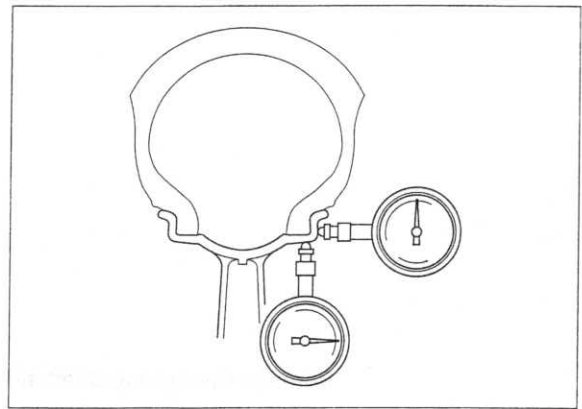

Wheel balance

- Wheel balance directly affects the stability, handling and overall safety of the motorcycle. Always check balance when the tire has been removed from the rim.
- For optimum balance, the tire balance mark (a paint dot on the side wall) must be located next to the valve stem. Remount the tire if necessary.

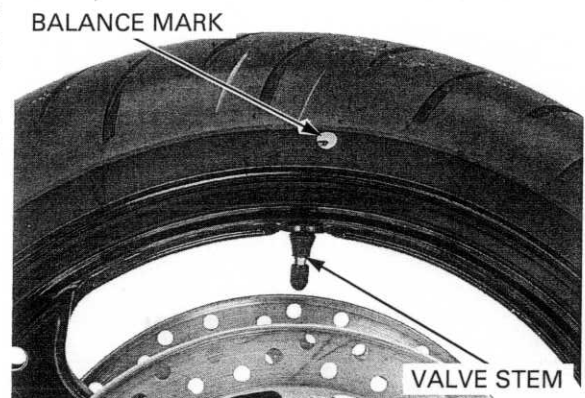

Note the rotating direction marks on the wheel and tire.

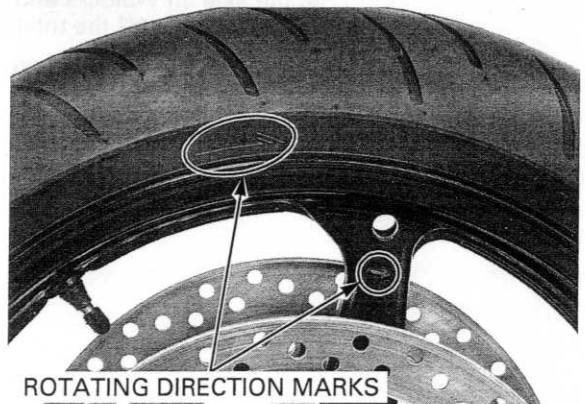

Remove the dust seals from the wheel.
Mount the wheel, tire and brake discs assembly in an inspection stand.
Spin the wheel, allow it to stop, and mark the lowest (heaviest) point of the wheel with a chalk.
Do this two or three times to verify the heaviest area.
If the wheel is balanced, it will not stop consistently in the same position.

To balance the wheel, install the wheel weights on the highest side of the rim, the side opposite the chalk marks. Add just enough weight so the wheel will no longer stop in the same position when it is spun. Do not add more than 60 grams to the wheel.

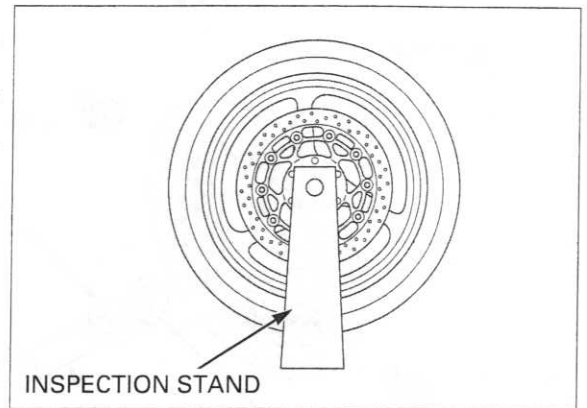

DISASSEMBLY

Remove the bolts and brake discs.
Remove the dust seals.

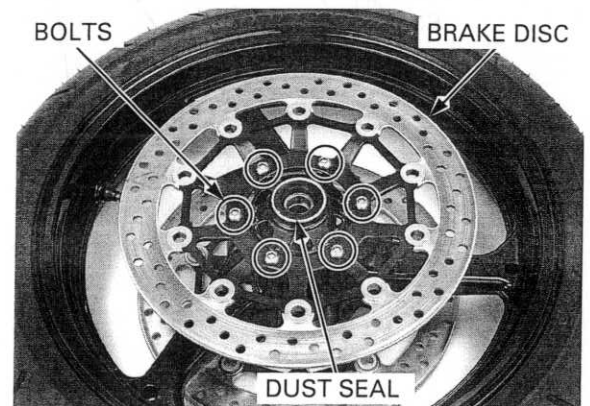

Install the bearing remover head into the bearing.
From the opposite side, install the bearing remover shaft and drive the bearing out of the wheel hub.
Remove the distance collar and drive out the other bearing.

TOOLS:

Bearing remover head, 20 mm 07746-0050600
Bearing remover shaft 07GGD-0010100

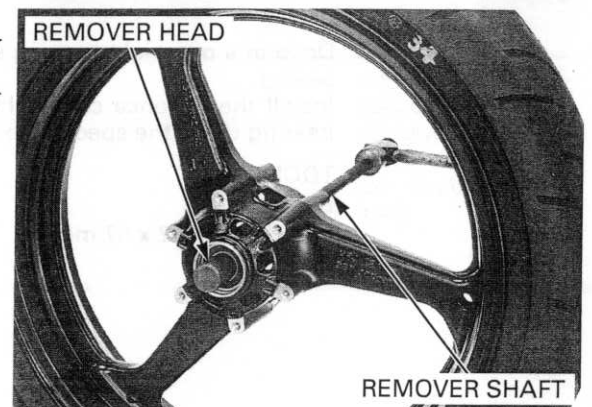

FRONT WHEEL/SUSPENSION/STEERING

ASSEMBLY

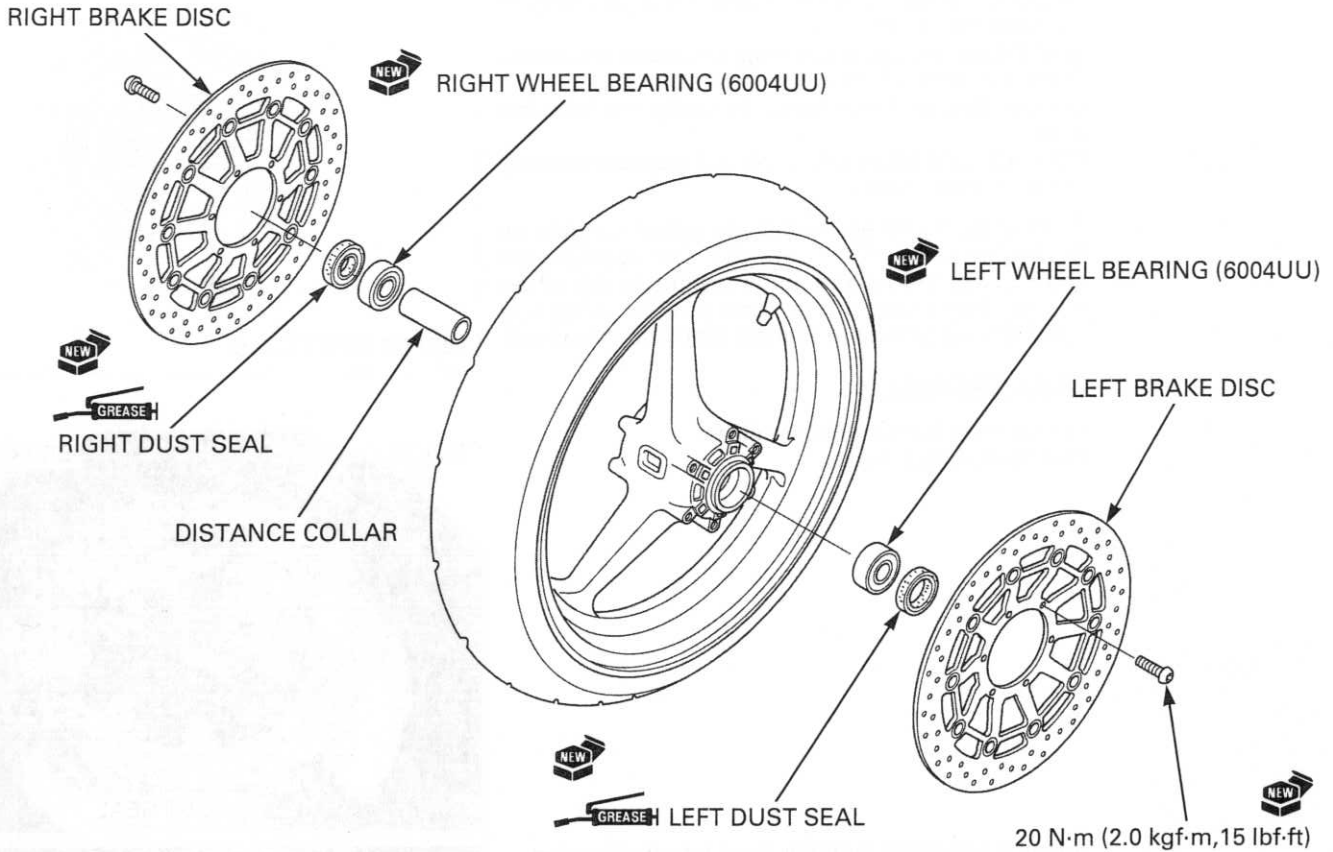

Never install the old bearings. Once the bearings have been removed, the bearings must be replaced with new ones.

Drive in a new right bearing squarely until it is fully seated. Install the distance collar, then drive in a new left bearing using the special tools.

TOOLS:

- Driver**
- Attachment, 42 x 47 mm**
- Pilot, 20 mm**

- 07749-0010000**
- 07746-0010300**
- 07746-0040500**

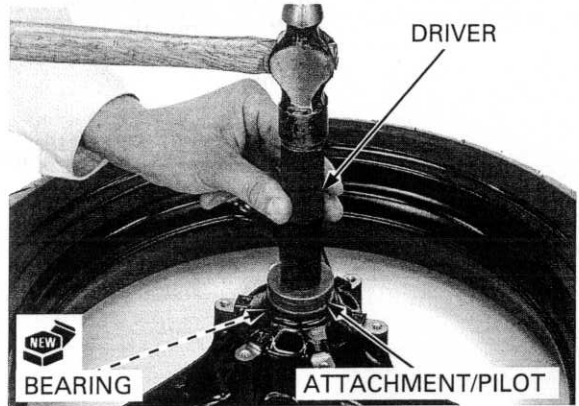

Check the spokes on the wheel for the direction mark.

Install the brake discs with the arrow mark facing in the direction of rotation. Install new disc bolts and tighten them in a criss-cross pattern in two or three steps.

TORQUE: 20 N·m (2.0 kgf·m, 15 lbf·ft)

Apply grease to new dust seal lips, then install them into the wheel hub.

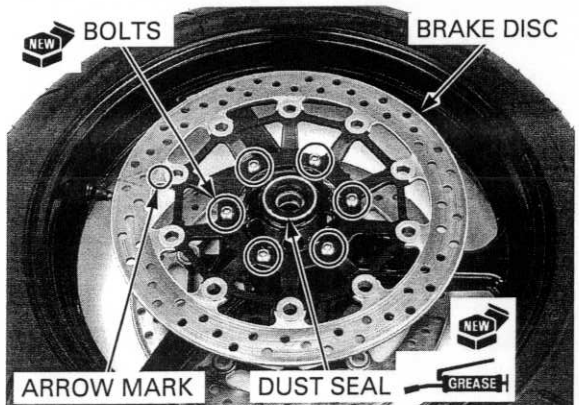

INSTALLATION

Install the right and left side collars.

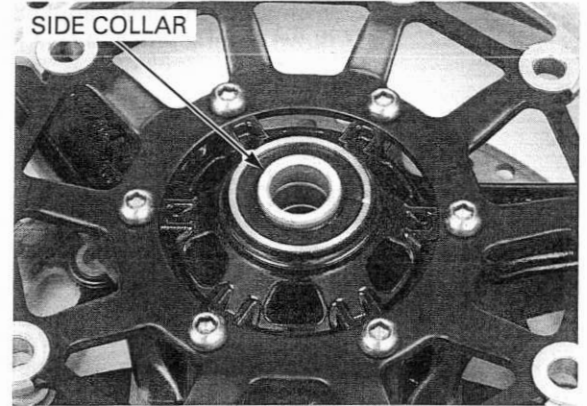

Install the front wheel between the fork legs.
Apply a thin layer of grease to the front axle surface.
Install the front axle from the left side.

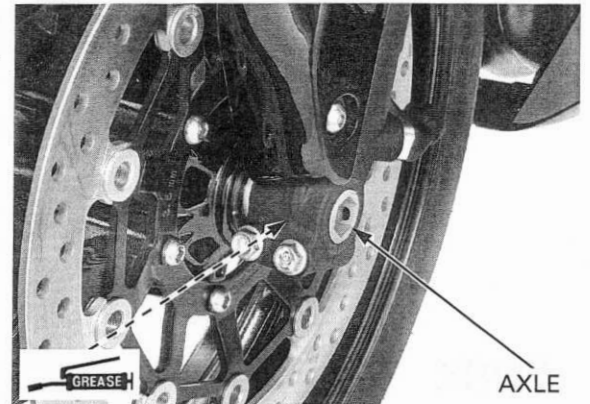

Hold the axle and tighten the axle bolt to the specified torque.

TORQUE: 59 N·m (6.0 kgf·m, 44 lbf·ft)

Tighten the right axle holder bolts to the specified torque.

TORQUE: 22 N·m (2.2 kgf·m, 16 lbf·ft)

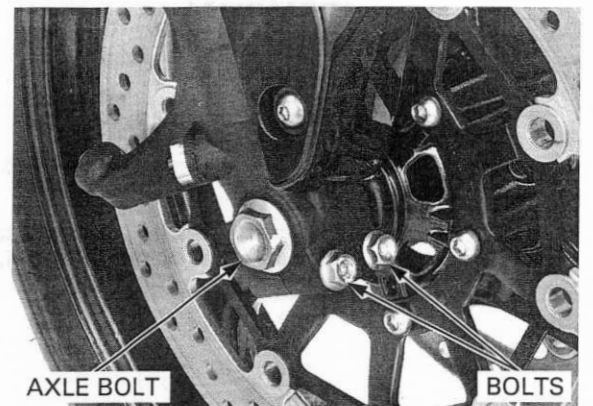

Install both brake calipers and tighten new mounting bolts to the specified torque.

TORQUE: 45 N·m (4.6 kgf·m, 33 lbf·ft)

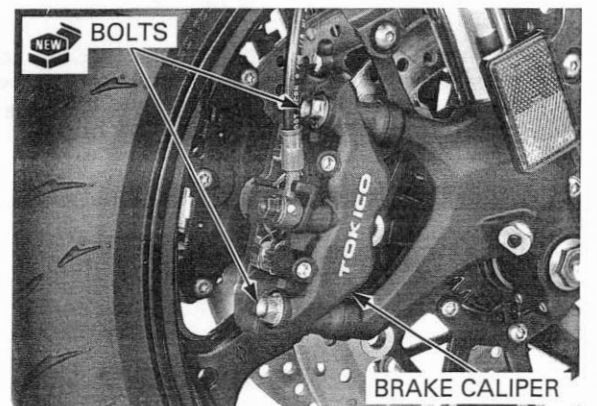

FRONT WHEEL/SUSPENSION/STEERING

Check the brake operation by applying the brake lever.

With the front brake applied, pump the fork up and down several times to seat the axle.



Tighten the left axle holder bolts to the specified torque.

TORQUE: 22 N·m (2.2 kgf·m, 16 lbf·ft)

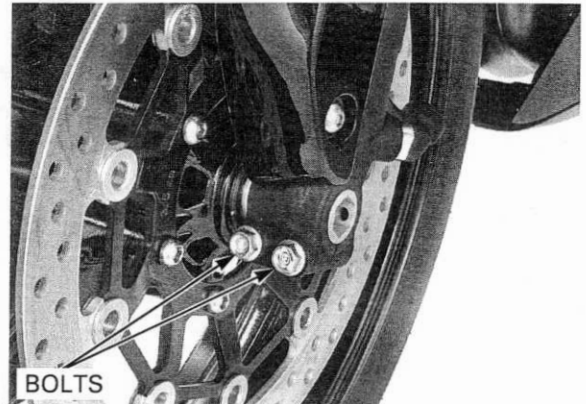

FORK

REMOVAL

Remove the following:

- Front wheel (page 14-16)
- Front fender (page 3-13)

Loosen the handlebar pinch bolt and top bridge pinch bolt.

When the fork leg will be disassembled, loosen the fork bolt, but do not remove it yet.

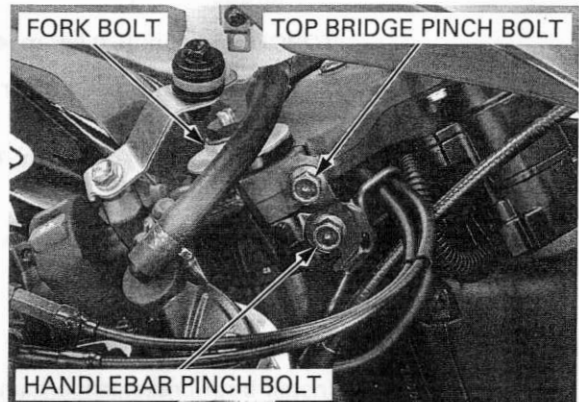

Keep the front brake master cylinder reserve tank upright.

While holding the fork leg, loosen the fork bottom bridge pinch bolts and remove the fork slider from the handlebar and fork bridges.

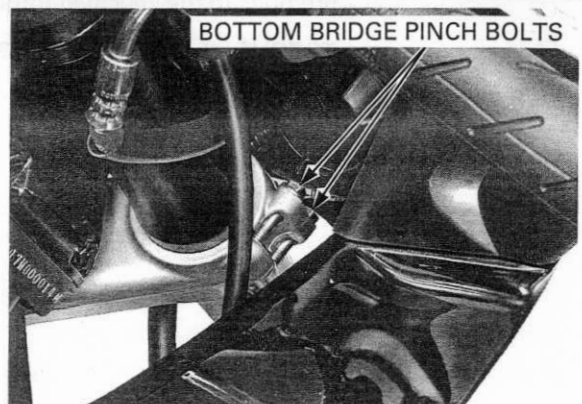

When disassembling the fork leg, turn the pre-load, rebound and compression damping adjusters counterclockwise to the softest position (be sure to record the number of turns from the starting position).

REBOUND ADJUSTER

COMPRESSION ADJUSTER

PRE-LOAD ADJUSTER

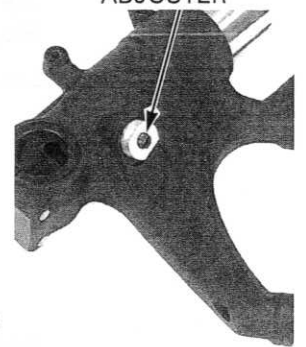

DISASSEMBLY

Be careful not to scratch the fork slider.

- Remove the handlebar stopper ring.
- Remove the fork bolt from the fork slider.

FORK BOLT

FORK SLIDER

STOPPER RING

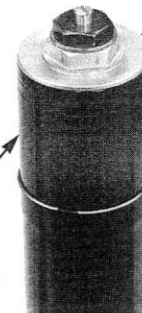

Push the fork slider slowly down, and gently seat the dust seal onto the axle holder.

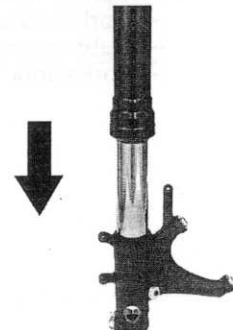

Be careful not to damage the spring collar holes.

Set the spring collar holder to the spring collar holes.

TOOL:
Spring collar holder **070MF-MBZC110**

Compress the spring collar with the spring collar holder.

SPRING COLLAR HOLDER

SPRING COLLAR

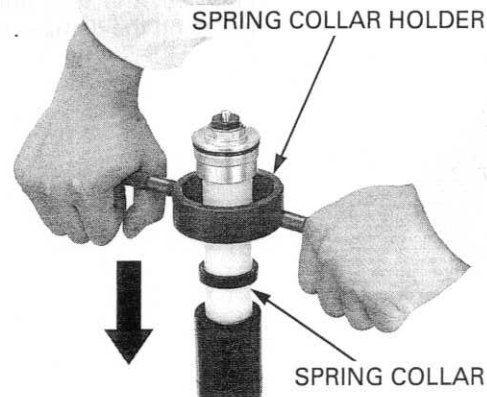

FRONT WHEEL/SUSPENSION/STEERING

Insert the stopper plate between the lock nut and spring seat stopper.

TOOL:

Stopper plate

070MF-MBZC130

Loosen the lock nut while holding the fork bolt.

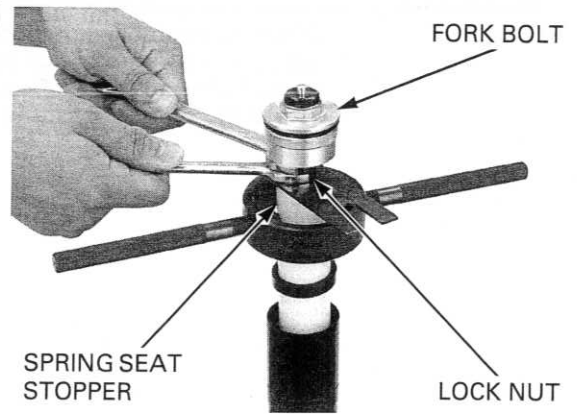

Remove the fork bolt.
Remove the stopper plate and spring collar holder.

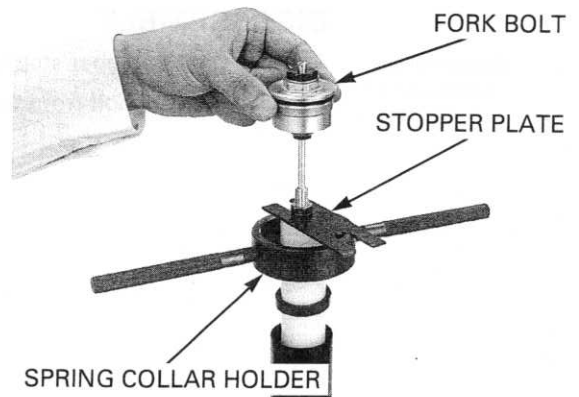

Remove the following:

- Spring seat stopper
- Spring collar
- Rubber seal
- Fork spring

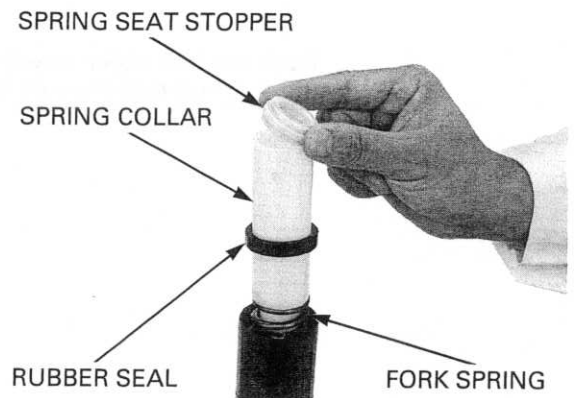

Pour out the fork fluid by pumping the fork tube several times.

Pour out the fork fluid from the fork damper by pumping the damper rod several times.

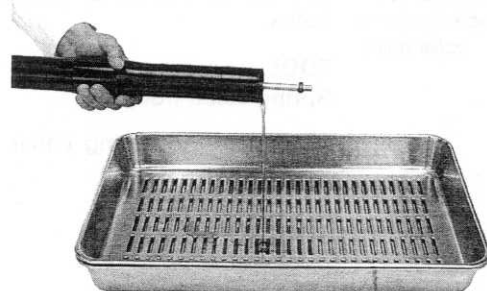

FRONT WHEEL/SUSPENSION/STEERING

Remove the compression damping adjuster from the axle holder.

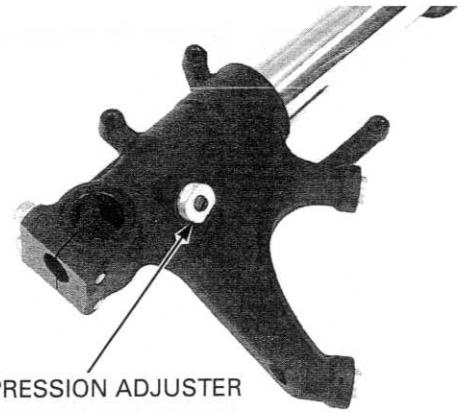

COMPRESSION ADJUSTER

Remove the adjuster piece from the plug bolt.
Remove the O-rings.

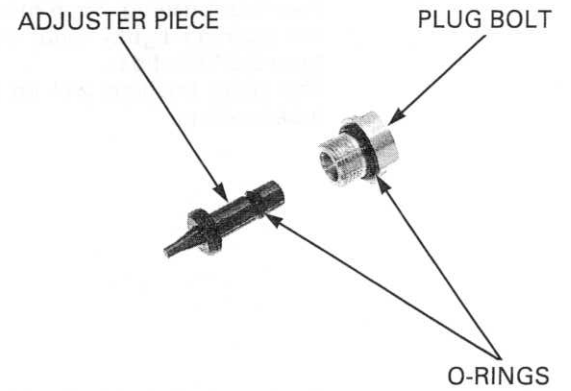

ADJUSTER PIECE

PLUG BOLT

O-RINGS

Hold the axle holder in a vise with soft jaws or a shop towel.
Hold the fork damper with the special tool, then remove the fork socket bolt and sealing washer.

TOOL:

Fork damper holder

07YMB-MCF0101



SOCKET BOLT/
SEALING WASHER

Remove the fork damper assembly from the fork slider.

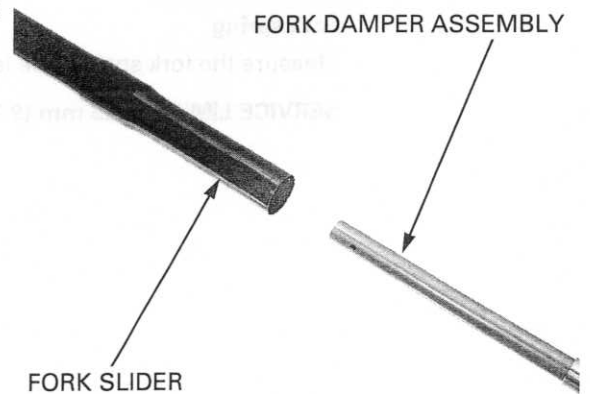

FORK SLIDER

FORK DAMPER ASSEMBLY

FRONT WHEEL/SUSPENSION/STEERING

Remove the dust seal.

*Do not scratch the
fork tube sliding
surface.* Remove the oil seal stopper ring.

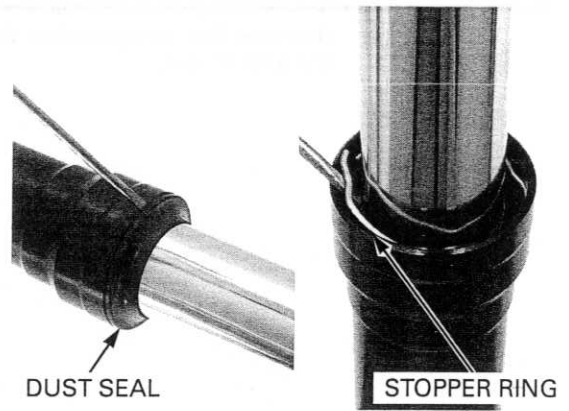

Pull the fork tube out until you feel resistance from the slider bushing. Then move it in and out, tapping the bushing lightly until the fork tube separates from the fork slider. The slider bushing will be forced out by the fork tube bushing.

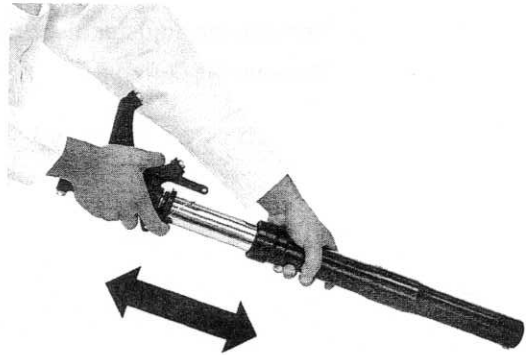

Remove the fork tube bushing, slider bushing, back-up ring, oil seal, stopper ring and dust seal from the fork tube.

Remove the following:

- Fork tube bushing
- Slider bushing
- Back up ring
- Oil seal
- Stopper ring
- Dust seal

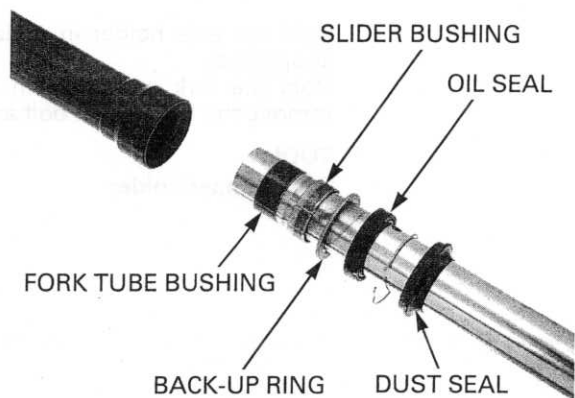

INSPECTION

Fork spring

Measure the fork spring free length.

SERVICE LIMIT: 238.5 mm (9.39 in)

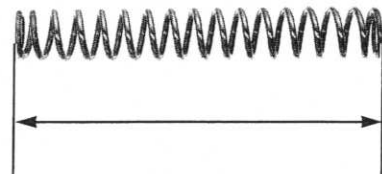

Fork tube/slider/damper

Check the fork slider for damage or deformation.
 Check the fork damper for bend or damage.
 Replace any components which are damaged.

FORK DAMPER

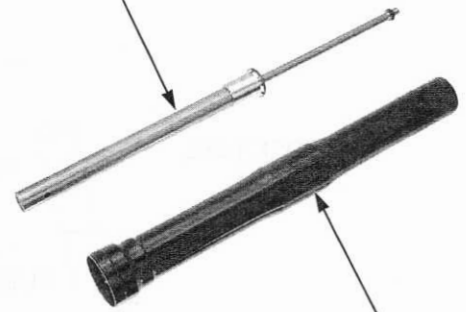

FORK SLIDER

Check the oil lock valve for wear or damage.
 Replace the fork damper assembly, if any components are damaged.

OIL LOCK VALVE

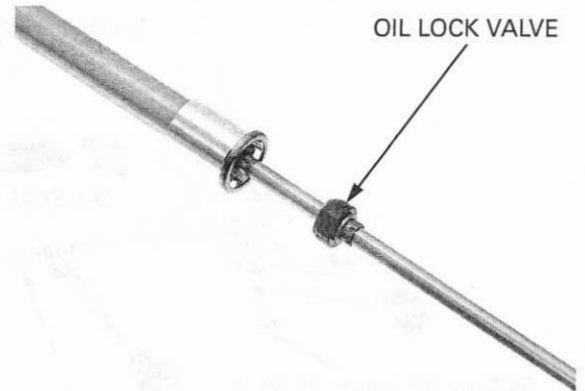

Check the fork tube for score marks, scratches, or excessive or abnormal wear.
 Place the fork tube on V-blocks and measure the runout.
 Actual runout is 1/2 the total indicator reading.

SERVICE LIMIT: 0.20 mm (0.008 in)

DIAL GAUGE

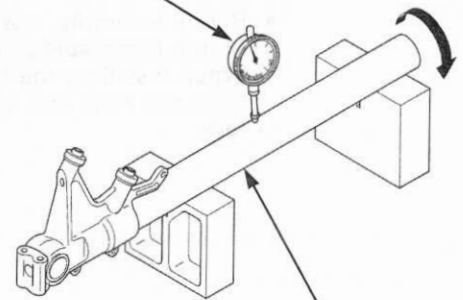

FORK TUBE

Fork tube bushing

Visually inspect the slider and fork tube bushings.
 Replace the bushings if there is excessive scoring or scratching, or if the teflon is worn so that the copper surface appears on more than 3/4 of the entire surface.

Check the back-up ring; replace it if there is any distortion at the points shown.

BUSHING

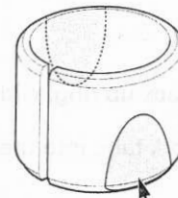

COPPER SURFACES

BACK-UP RING

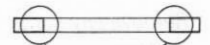

CHECK POINTS

FRONT WHEEL/SUSPENSION/STEERING

ASSEMBLY

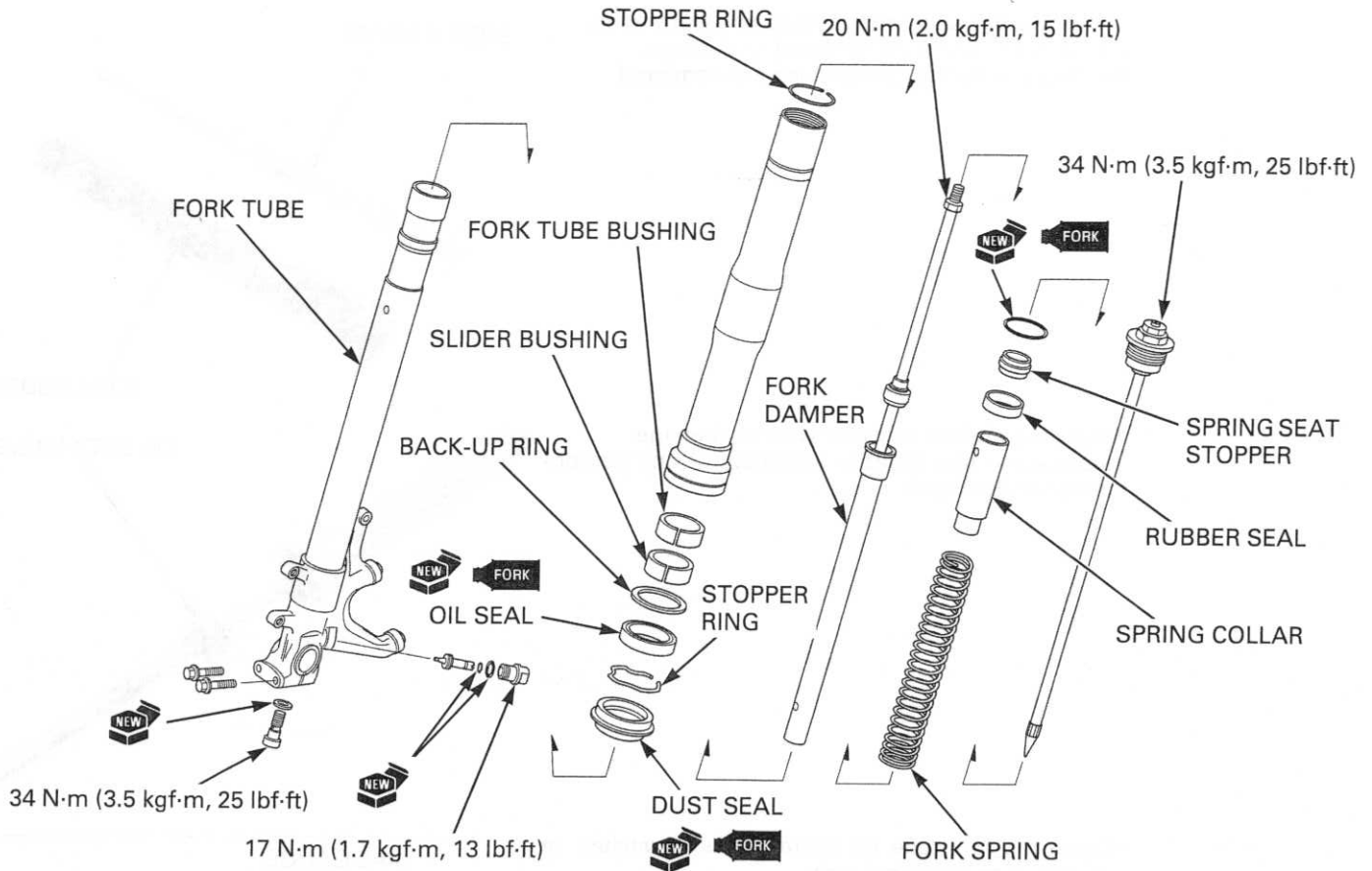

- Before assembly, wash all parts with a high flash or non-flammable solvent and blow them dry.
- When installing the fork dust seal and oil seal, wrap the edge and groove of the fork tube with tape.

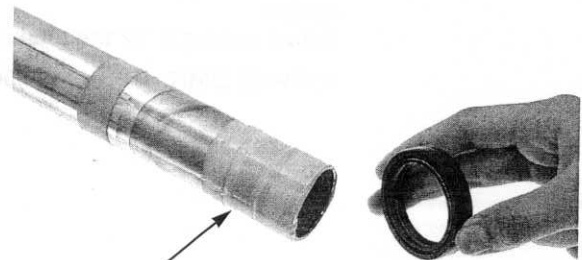

TAPE

Apply fork fluid to new dust seal and oil seal lips.

Install the oil seal with its marked side facing toward the axle holder.

Install the dust seal, stopper ring and oil seal.

Remove any burrs from the slider bushing mating surface, being careful not to peel off the coating.

Install the back-up ring, slider bushing and fork tube bushing.
Install the fork tube into the fork slider.

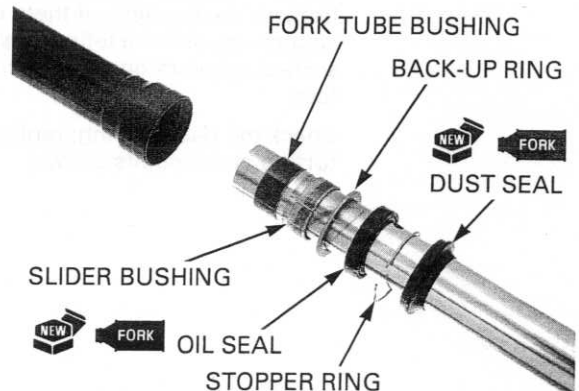

FRONT WHEEL/SUSPENSION/STEERING

Drive the oil seal in using the special tool.

TOOLS:

Fork seal driver 07KMD-KZ30100
Fork seal driver attachment 07RMD-MW40100

U.S.A. TOOL:

Fork seal driver 07NMD-KZ3010A

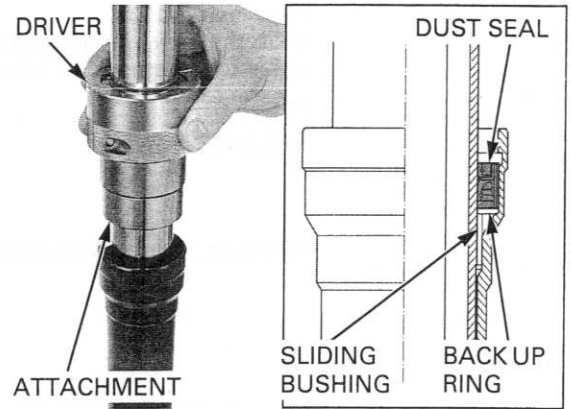

Do not scratch the fork tube sliding surface.

Install the stopper ring into the fork slider groove securely.

Install the dust seal into the fork slider.

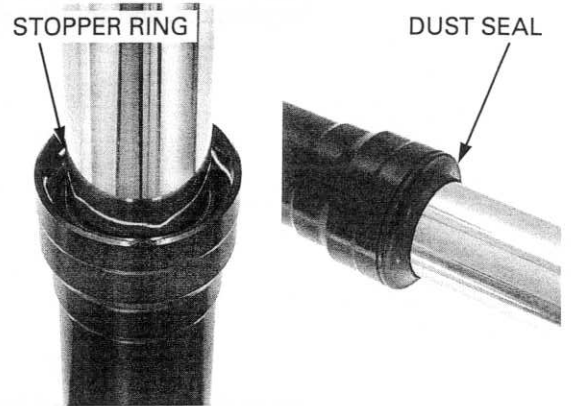

Install the fork damper assembly into the fork slider.

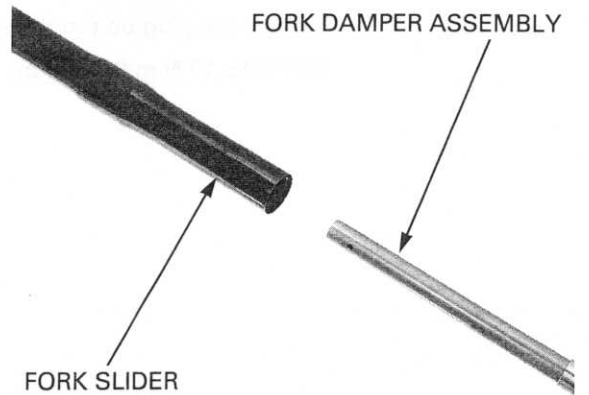

Install the socket bolt with a new sealing washer.



FRONT WHEEL/SUSPENSION/STEERING

Hold the axle holder in a vise with soft jaws or a shop towel.

Hold the fork damper with the special tool, then tighten the fork socket bolt to the specified torque.

TOOL:

Fork damper holder

07YMB-MCF0101 or
07YMB-MCFA100
(U.S.A. only)

TORQUE: 34 N·m (3.5 kgf·m, 25 lbf·ft)

Apply fork fluid to new O-rings, then install them to the plug bolt and adjuster piece.

Install the adjuster piece into the axle holder.

Tighten the plug bolt to the specified torque.

TORQUE: 17 N·m (1.7 kgf·m, 13 lbf·ft)

Pour the specified amount of recommended fork fluid into the fork slider.

RECOMMENDED FORK FLUID:

Pro Honda Suspension Fluid SS-47 (10W)

FORK FLUID CAPACITY:

$413 \pm 2.5 \text{ cm}^3$ ($14.0 \pm 0.08 \text{ US oz}$, $14.5 \pm 0.09 \text{ Imp oz}$)

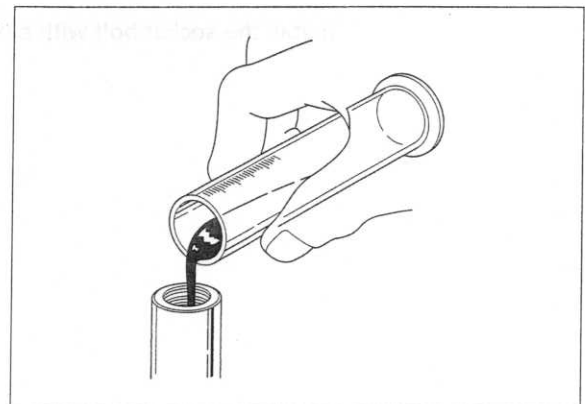
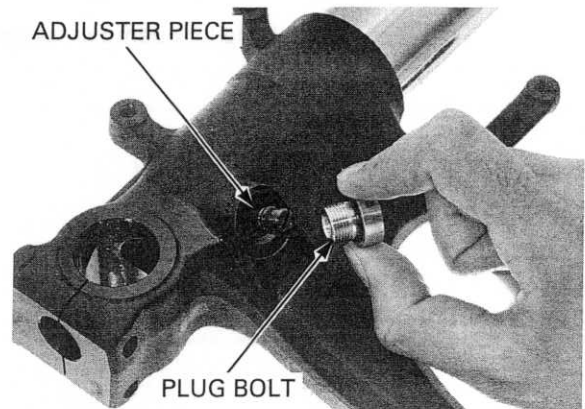
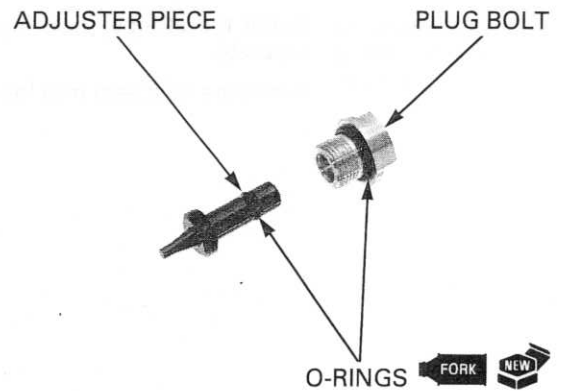
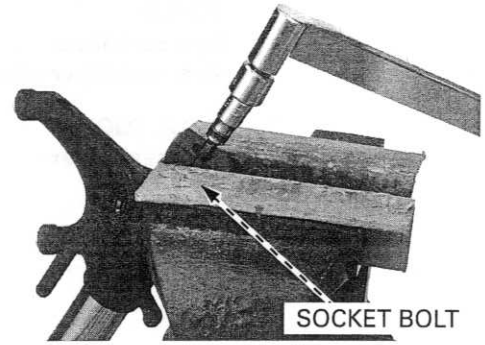

Bleed the air from the fork leg as follows:

1. Extend the fork, cover the top of the fork slider with your hand and compress the fork leg slowly.
2. Remove your hand and extend the fork slowly. Repeat above procedure 2 or 3 times.
3. Pump the fork damper rod slowly 8 – 10 times.

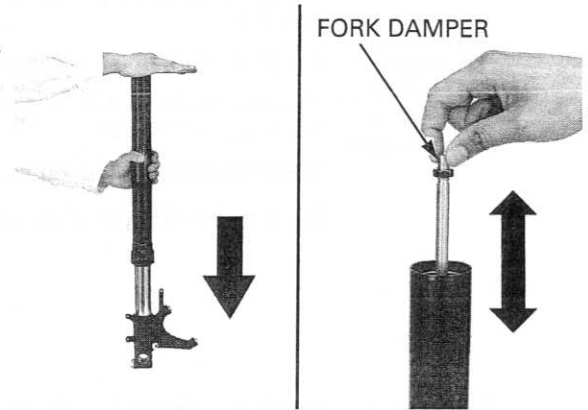

Slowly push the fork slider, and gently seat the dust seal onto the axle holder and leave it for 5 minutes.

Be sure the oil level is the same in the both forks.

After the oil level stabilizes, measure the oil level from the top of the fork slider.

FORK FLUID LEVEL: 93 mm (3.7 in)

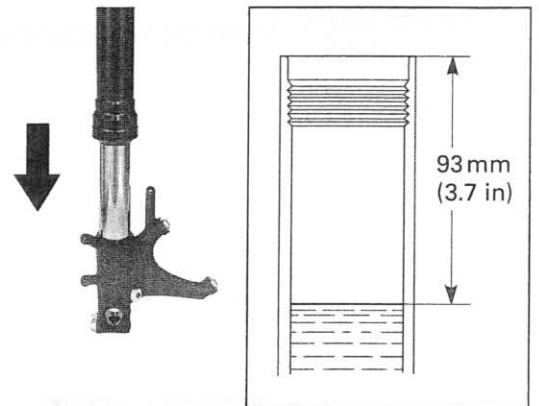

Install the fork spring into the fork slider with the tapered end facing up.

Extend the fork damper fully and install the damper rod holder onto the damper rod.

TOOL:
Damper rod holder **070MF-MBZC120**

Install the spring collar, rubber seal and spring seat stopper.

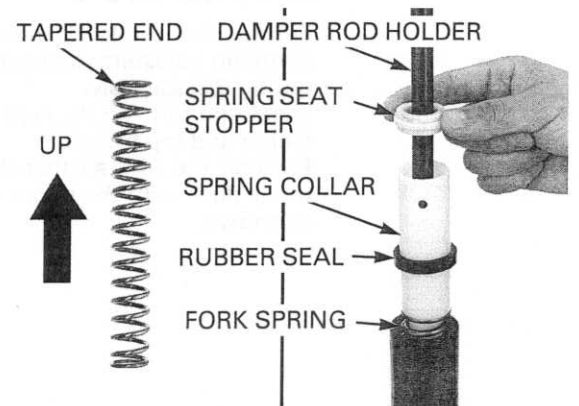

Set the spring collar holder to the spring collar holes.

TOOL:
Spring collar holder **070MF-MBZC110**

Compress the spring collar with the spring collar holder while pulling the damper rod holder up. Insert the stopper plate between the lock nut and spring seat stopper.

TOOL:
Stopper plate **070MF-MBZC130**

Remove the damper rod holder.

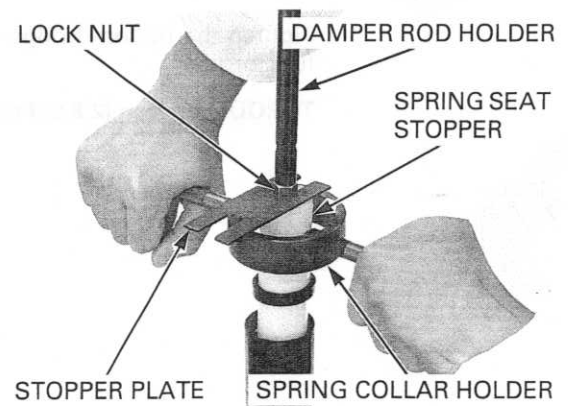

FRONT WHEEL/SUSPENSION/STEERING

Apply fork fluid to a new O-ring and install it to the fork bolt.

Tighten the fork bolt after installing the fork slider into the fork bridges.

Install the fork bolt to the fork damper.

Tighten the lock nut to the specified torque with holding the fork bolt.

TORQUE: 20 N·m (2.0 kgf·m, 15 lbf·ft)

Remove the stopper plate and spring collar holder.

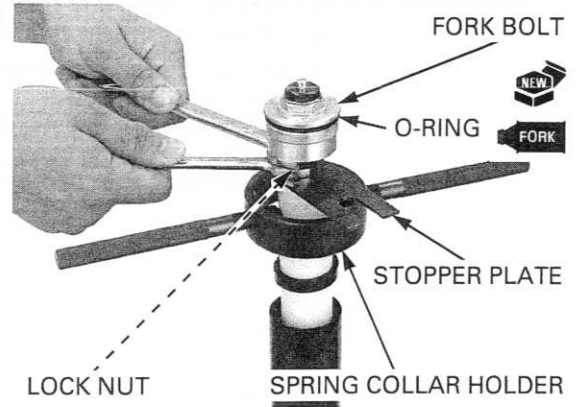

Tighten the fork bolt after installing the fork slider into the fork.

Install the fork bolt to the fork slider.

Install the handlebar stopper ring.

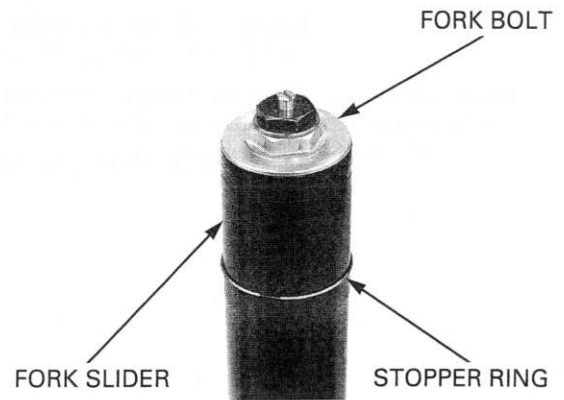

INSTALLATION

Return the pre-load, rebound and compression damping adjusters to the original positions as noted during disassembly.

Install the fork leg through the bottom bridge, handlebar and top bridge.

Position the fork so that the first groove from the top is flush with the upper surface of the top bridge as shown.

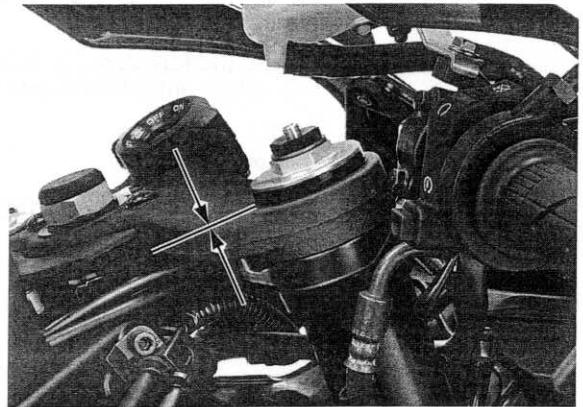

Tighten the bottom bridge pinch bolts to the specified torque.

TORQUE: 27 N·m (2.8 kgf·m, 20 lbf·ft)

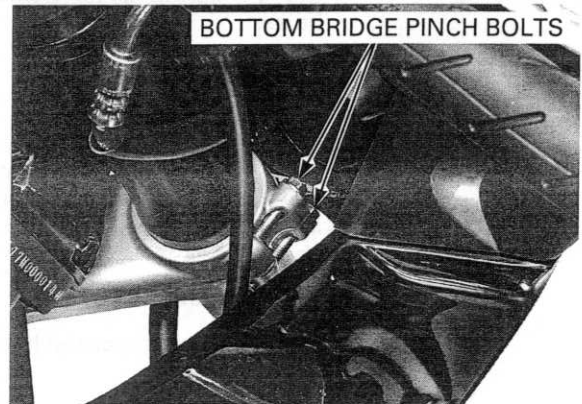

If the fork bolt is loosened, tighten it to the specified torque.

TORQUE: 34 N·m (3.5 kgf·m, 25 lbf·ft)

Tighten the top bridge pinch bolt to the specified torque.

TORQUE: 22 N·m (2.2 kgf·m, 16 lbf·ft)

Tighten the handlebar pinch bolt to the specified torque.

TORQUE: 27 N·m (2.8 kgf·m, 20 lbf·ft)

Install the following:

- Front fender (page 3-13)
- Front wheel (page 14-21)

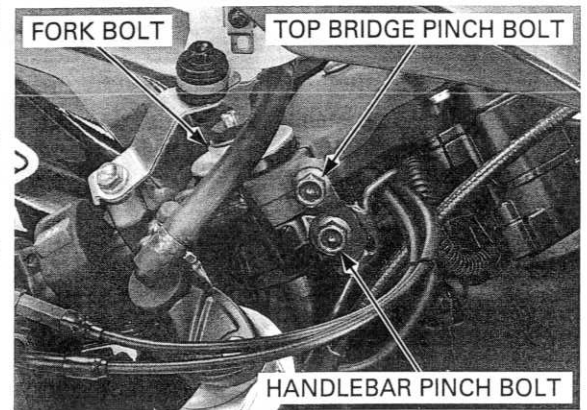

HESD

REMOVAL

Remove the fuel tank cover (page 3-9).

Remove the screws and steering damper cover. Remove the nut and disconnect the second arm from the top bridge.

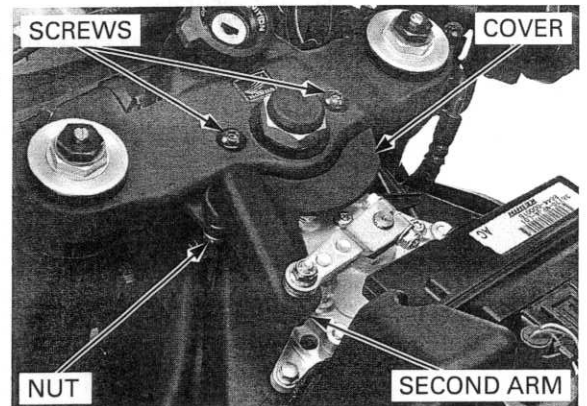

Remove the bolts and steering damper from the frame.

Disconnect the HESD 2P (Brown) connector from the steering damper.

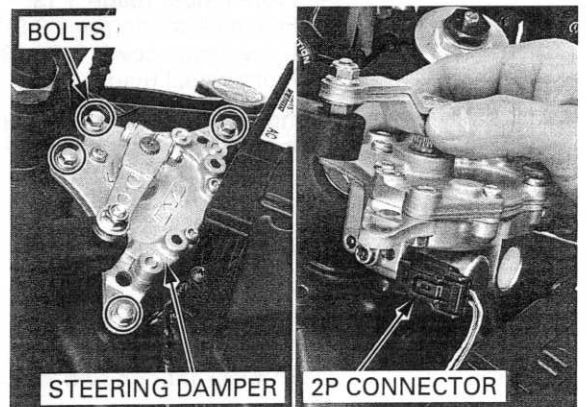

FRONT WHEEL/SUSPENSION/STEERING

INSTALLATION

Connect the HESD 2P (Brown) connector to the steering damper securely.

Install the steering damper onto the frame and tighten the bolts to the specified torque.

TORQUE: 10 N·m (1.0 kgf·m, 7 lbf·ft)

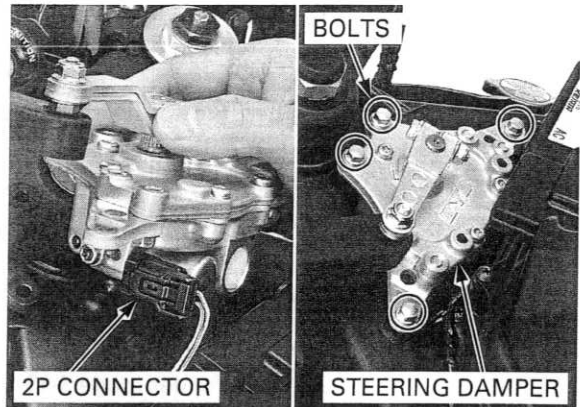

Connect the second arm to the top bridge and tighten the nut to the specified torque.

TORQUE: 12 N·m (1.2 kgf·m, 9 lbf·ft)

Install the steering damper cover and tighten the screws securely.

Install the fuel tank cover (page 3-9).

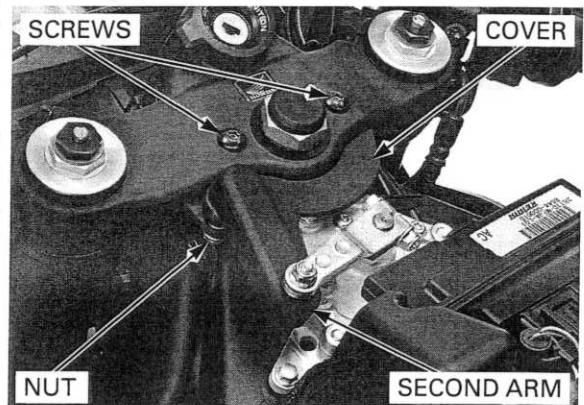

STEERING STEM

REMOVAL

Remove the following:

- Front fender (page 3-13)
- Fuel tank cover (page 3-9)
- Upper inner cowls (page 3-7)
- Front wheel (page 14-16)

Remove the nut and disconnect the second arm from the top bridge.

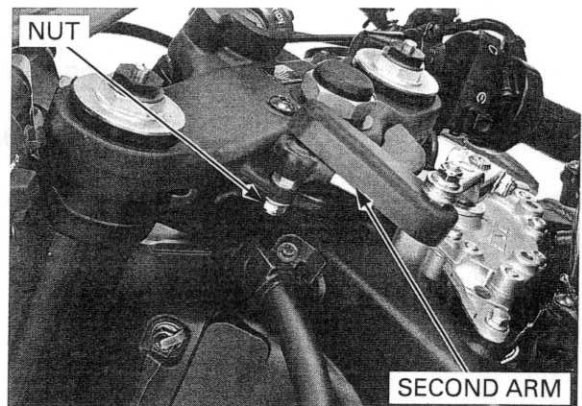

Disconnect the ignition switch 2P (Brown) connector.

Remove the bolt and wire clamp.

Remove the steering stem cap.

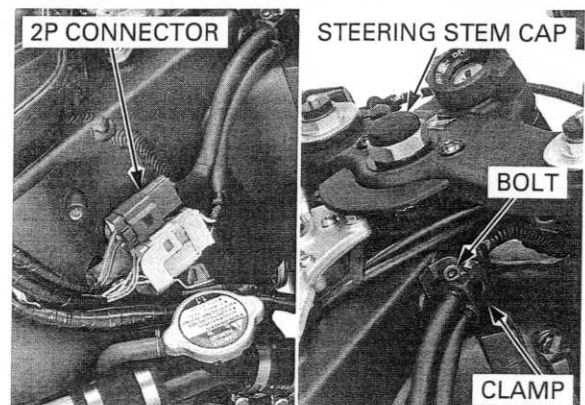

FRONT WHEEL/SUSPENSION/STEERING

Remove the screws and steering damper cover.
Remove the steering stem nut.
Remove the forks (page 14-22).

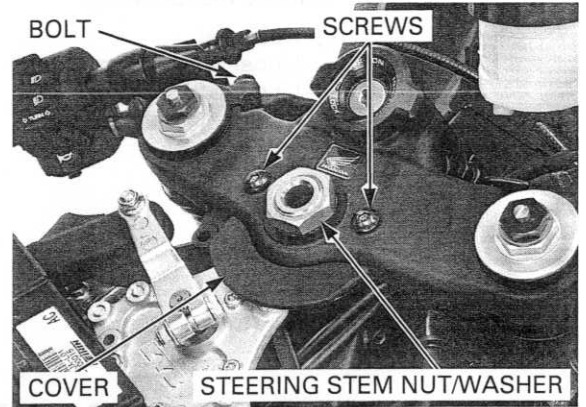

Remove the bolt and front brake hose clamp.

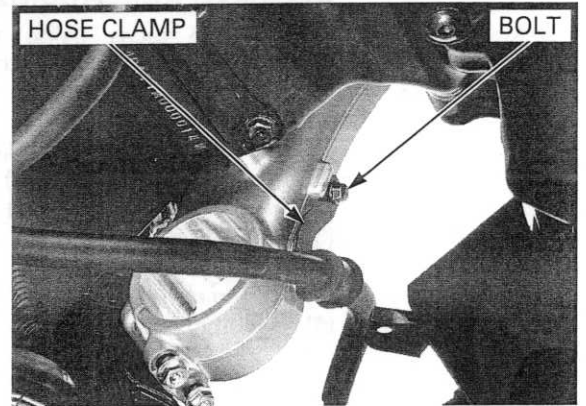

Straighten tabs lock washer tabs.
Remove the adjusting lock nut and lock washer.

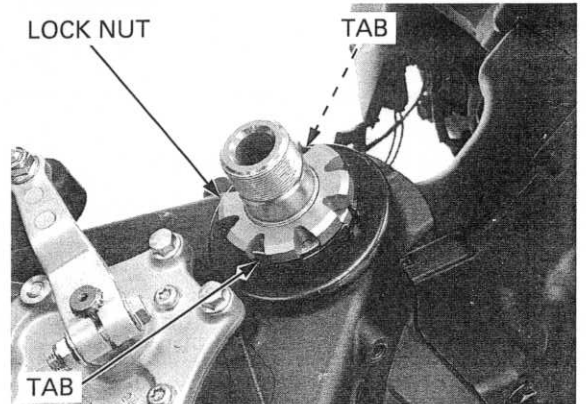

Remove the steering stem adjusting nut using the special tool.

TOOL:
Steering stem socket

07916-3710101 or
07916-3710100
(U.S.A. only)

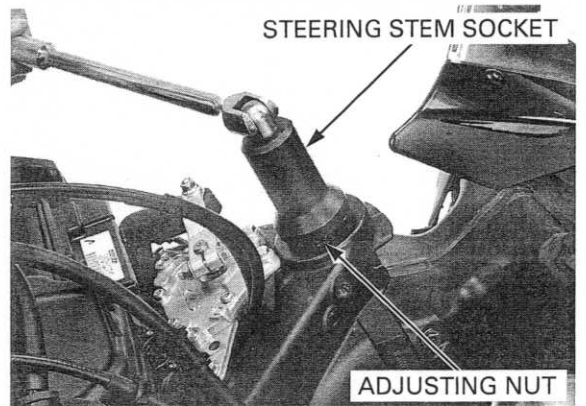

FRONT WHEEL/SUSPENSION/STEERING

Remove the following:

- Dust seal
- Upper bearing inner race
- Upper bearing
- Steering stem
- Lower bearing

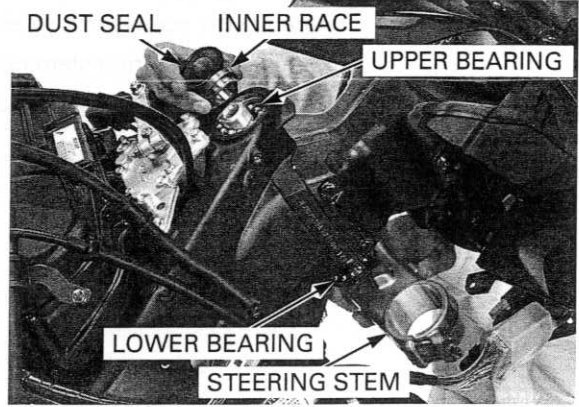

BEARING REPLACEMENT

Always replace the bearings and races as a set.

Replace the races using the special tools as described in the following procedure.

Except U.S.A.:

TOOLS: (Not available in U.S.A.)

- | | |
|-------------------------------|---------------|
| (1) Driver attachment (upper) | 070MF-MCJ0100 |
| (2) Driver attachment (lower) | 070MF-MCJ0200 |
| (3) Driver shaft assembly | 07946-KM90301 |
| (4) Bearing remover, A | 07946-KM90401 |
| (5) Bearing remover, B | 07NMF-MT70110 |
| (6) Assembly base | 07946-KM90600 |

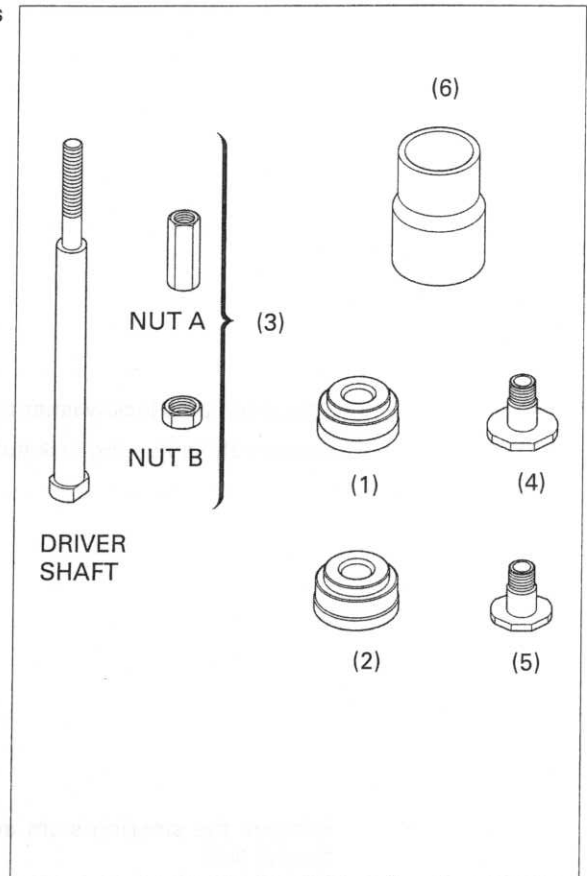

FRONT WHEEL/SUSPENSION/STEERING

Note the installation direction of the assembly base; the small I.D. side facing the upper attachment.

Install the special tools into the steering head as shown.

Align the bearing remover A with the grooves in the steering head.

Lightly tighten the nut B with a wrench.

Holding the driver shaft with a wrench, turn the nut A gradually to remove the upper outer race.

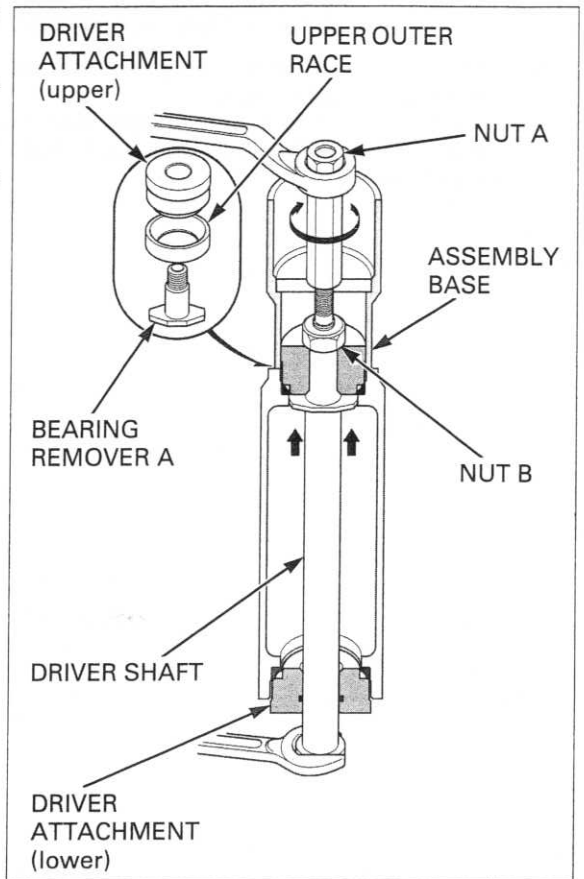

Note the installation direction of the assembly base; the large I.D. side facing the lower attachment.

Install the special tools into the steering head as shown and remove the lower outer race using the same procedure as for the upper outer race.

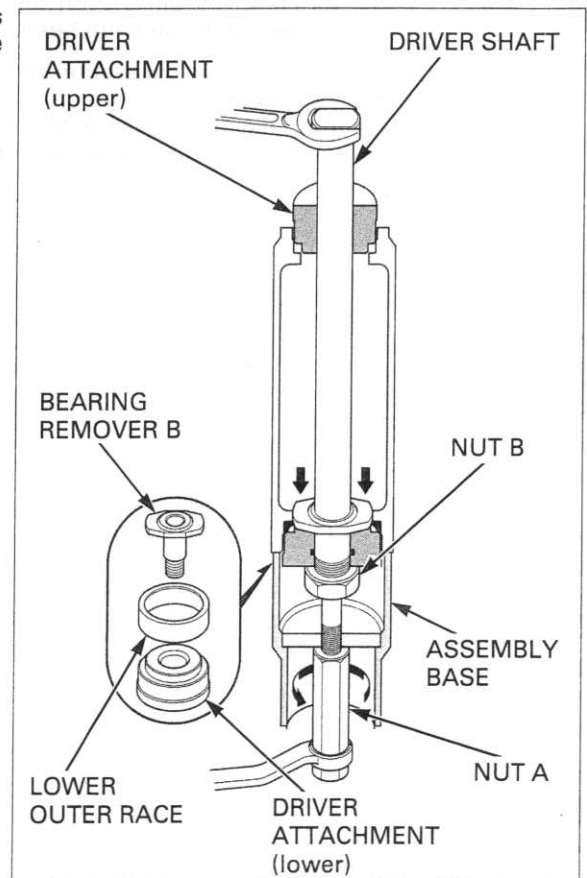

FRONT WHEEL/SUSPENSION/STEERING

Remove any burrs from the outer race installation surface of the steering head.

Note the installation direction of the assembly base; the large I.D. side facing the lower attachment.

Install a new upper outer race with the special tools as shown.
Hold the driver shaft with a wrench and turn the nut A gradually until upper outer race is fully seated.

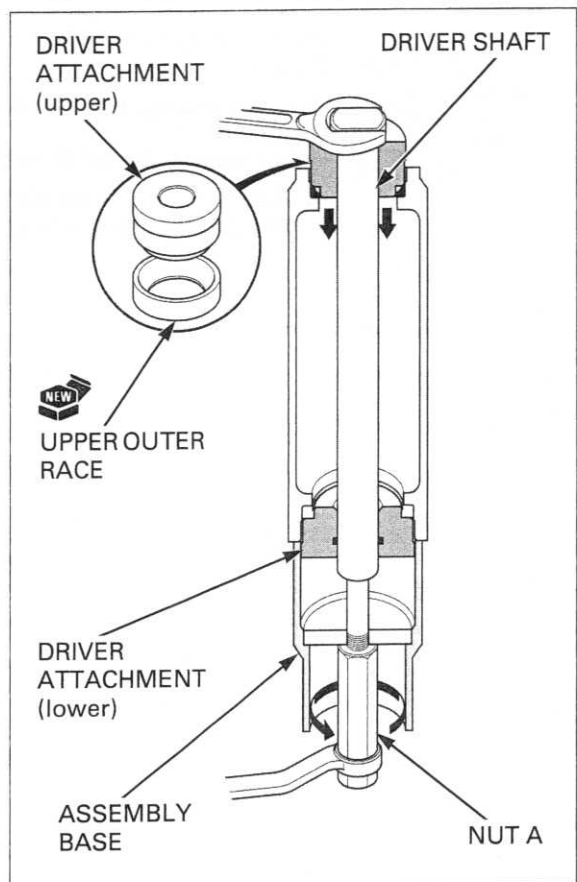

Remove any burrs from the outer race installation surface of the steering head.

Note the installation direction of the assembly base; the small I.D. side facing the upper attachment.

Install a new lower outer race with the special tools as shown.
Hold the driver shaft with a wrench and turn the nut A gradually until lower outer race is fully seated.

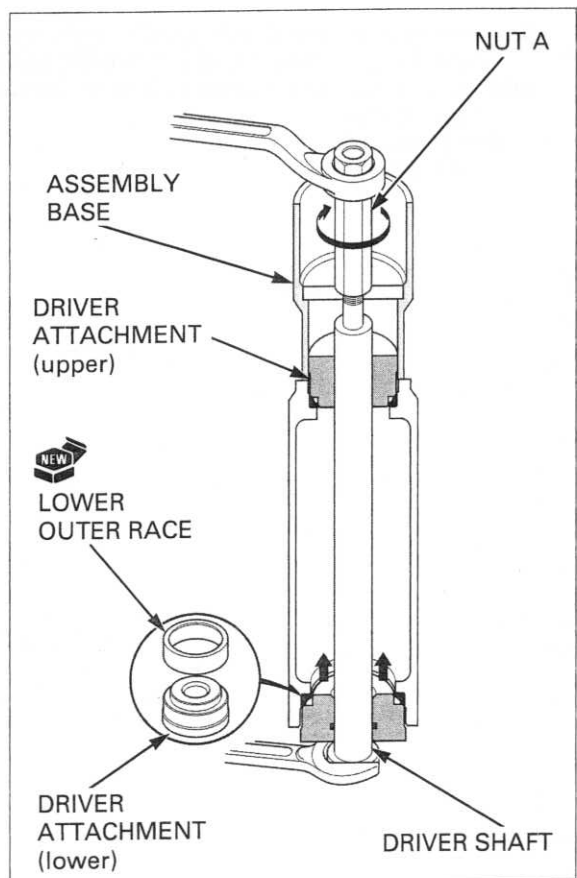

U.S.A. only:

TOOLS:

Main bearing driver attachment	07946-ME90200
Fork seal driver weight	07947-KA50100
Oil seal driver	07965-MA60000
Installer shaft	07VMF-KZ30200
Installer attachment A	07VMF-MAT0100
Installer attachment B	07VMF-MAT0200
Remover attachment C	07AMF-MEEA100
Remover attachment D	07AMF-MEEA200

Install the special tools into the steering head pipe as shown.

Align the remover attachment C with the groove in the steering head.

While holding the installer shaft with the wrench, turn the upper nut gradually to remove the upper bearing outer race.

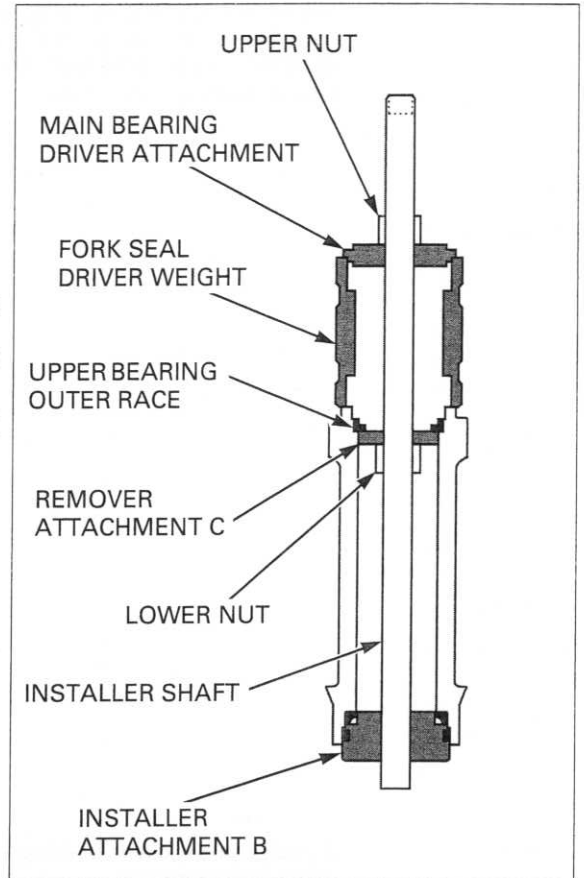

Install the special tools into the steering head pipe as shown.

Align the remover attachment D with the groove in the steering head.

While holding the installer shaft with the wrench, turn the lower nut gradually to remove the lower bearing outer race.

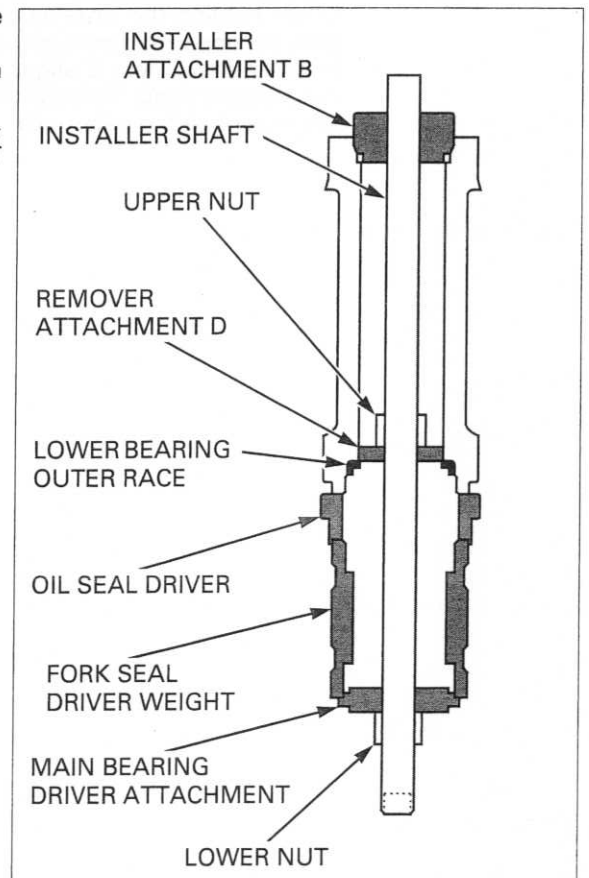

FRONT WHEEL/SUSPENSION/STEERING

Install a new upper bearing outer race and the special tools as shown.
While holding the installer shaft with the wrench, turn the lower nut gradually until the groove in the steering head. This will allow you to install the upper bearing outer race.

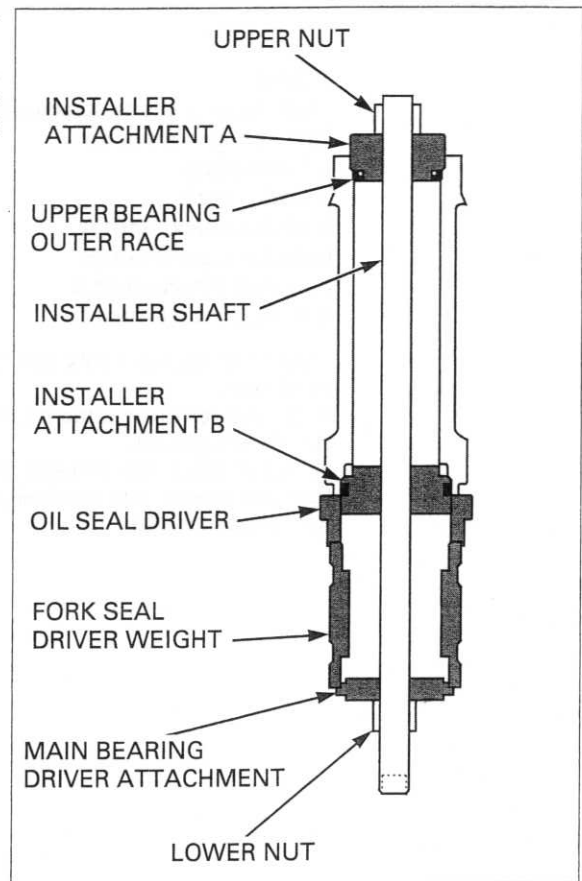

Install a new lower bearing outer race and the special tools as shown.
While holding the installer shaft with the wrench, turn the upper nut gradually until the groove in the installer attachment B aligns with the lower end of the steering head. This will allow the installation of the lower bearing outer race.

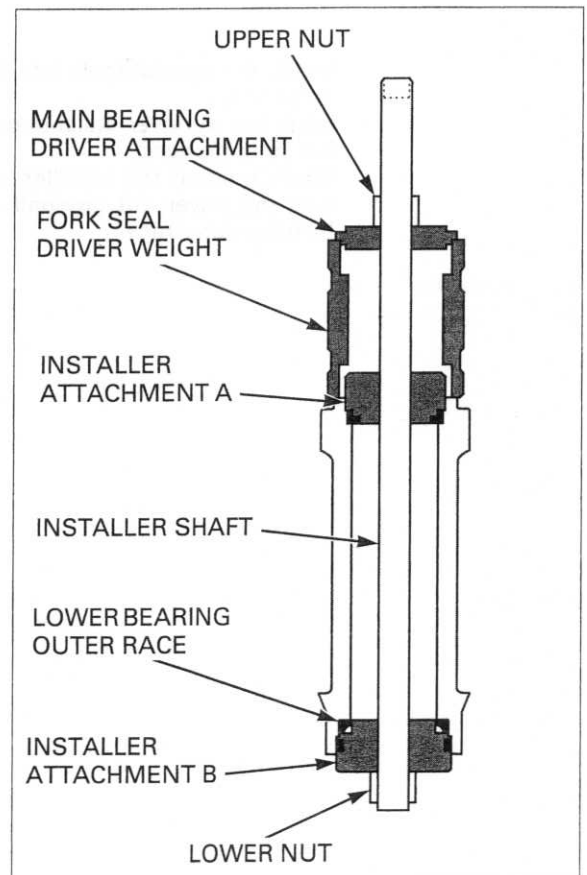

LOWER INNER RACE REPLACEMENT

Temporarily install the steering stem nut onto the stem to prevent the threads from being damaged when removing the lower bearing inner race from the stem.

Remove the lower bearing inner race with a chisel or equivalent tool, being careful not to damage the stem.

Remove the dust seal.

Apply grease to a new dust seal lips and install it over the steering stem.
Install a new lower bearing inner race using a special tool and a hydraulic press.

TOOL:

Attachment, 30 mm I.D.

07746-0030300

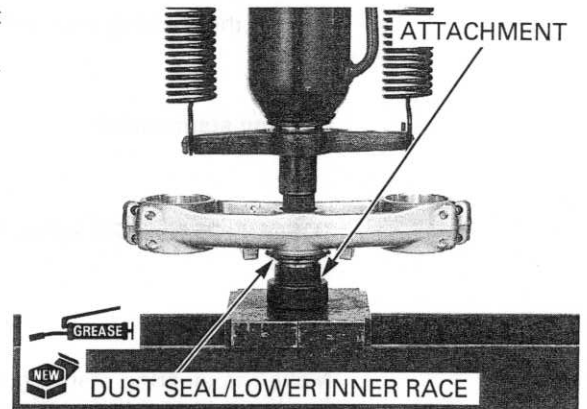
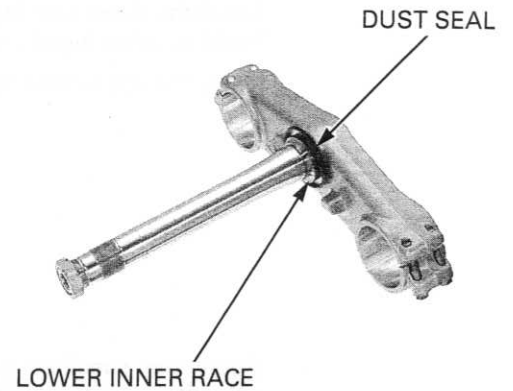

INSTALLATION

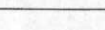
-  : BEARINGS
-  : BEARING RACES
-  : DUST SEALS

STEERING STEM

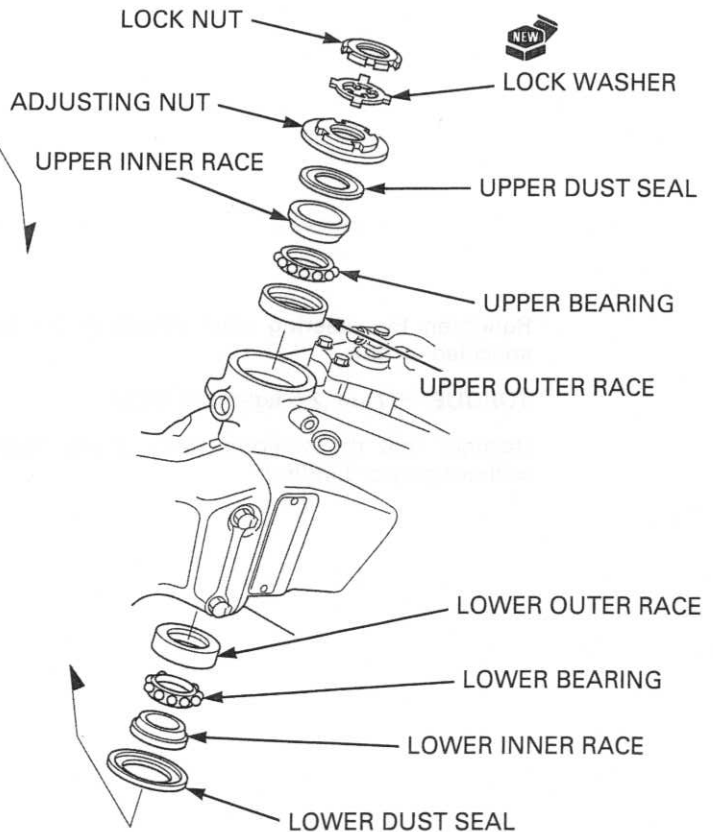
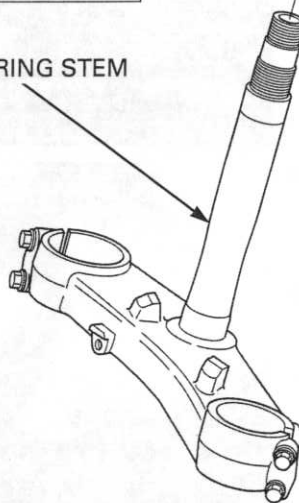

FRONT WHEEL/SUSPENSION/STEERING

Apply the specified grease (page 1-19) to the upper and lower bearings and bearing races.

Install the lower bearing onto the steering stem. Insert the steering stem into the steering head pipe.

Install the upper bearing, inner race and dust seal.

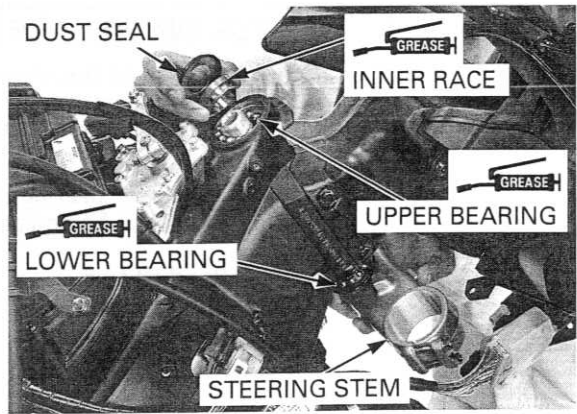

Apply the specified grease to the steering stem adjusting nut threads (page 1-19).

Tighten the steering stem adjusting nut to the initial torque.

TOOL:

Steering stem socket

**07916-3710101 or
07916-3710100
(U.S.A. only)**

TORQUE: 25 N·m (2.5 kgf·m, 18 lbf·ft)

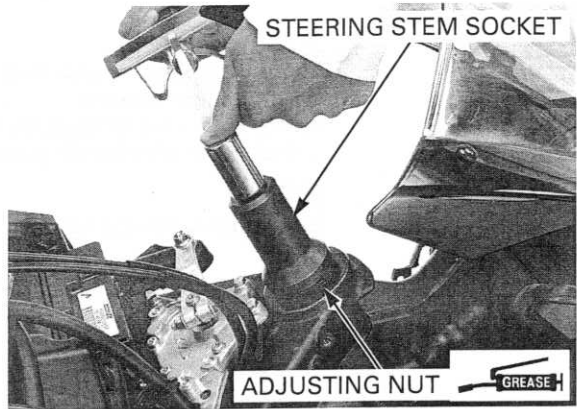

Move the steering stem right and left, lock-to-lock, five times to seat the bearings.

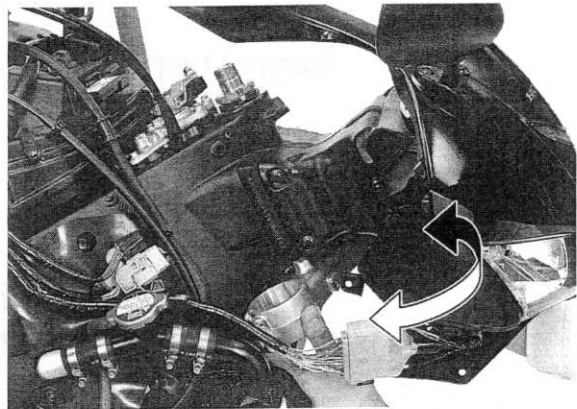

Retighten the steering stem adjusting nut to the specified torque.

TORQUE: 25 N·m (2.5 kgf·m, 18 lbf·ft)

Recheck that the steering stem moves smoothly without play or binding.

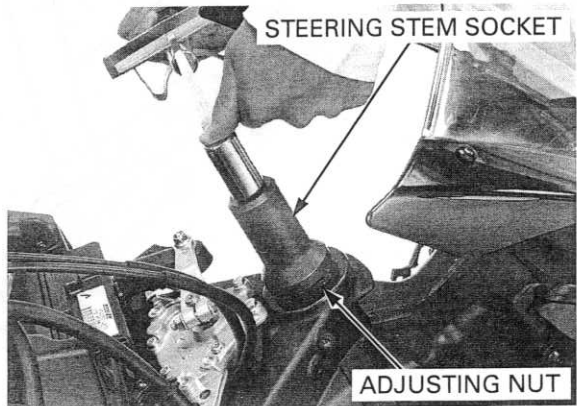

Install a new lock washer onto the steering stem.

Align the tabs of the lock washer with the grooves in the adjusting nut and bend two opposite tabs down into the adjusting nut groove.

Install and finger tighten the lock nut.

Hold the adjusting nut and further tighten the lock nut within 1/4 turn (90°) enough to align its grooves with the lock washer tabs.

Bend the lock washer tabs up into the lock nut grooves.

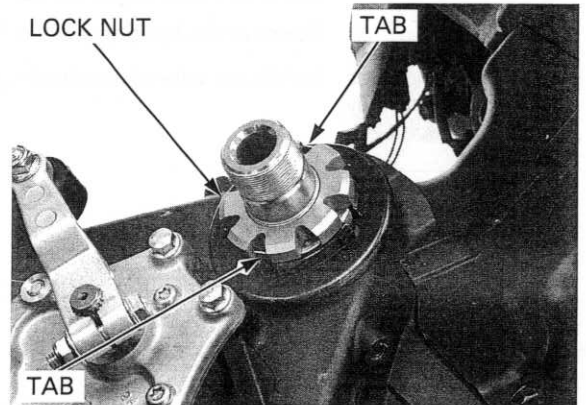
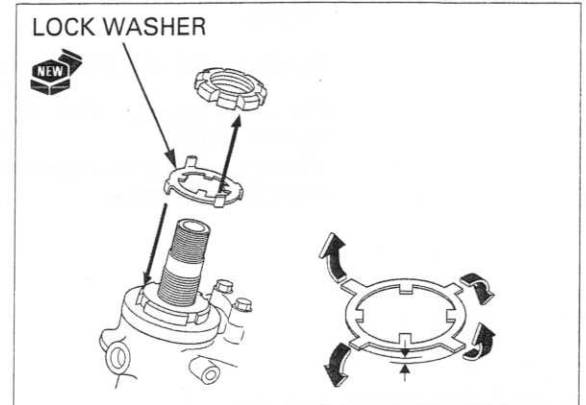

Route the brake hose properly (page 1-21).

Install the front brake hose clamp and tighten the bolt to the specified torque.

TORQUE: 9.0 N·m (0.9 kgf·m, 6.6 lbf·ft)

Install the forks (page 14-32).

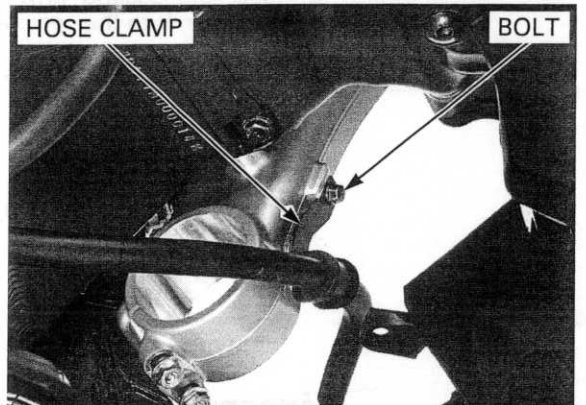

Install the top bridge and steering stem nut.

Install the steering damper cover and tighten the screws securely.

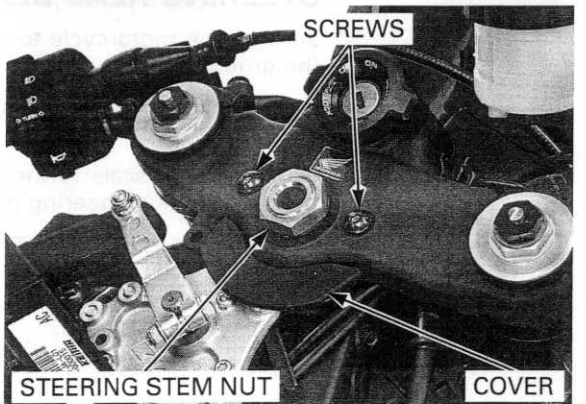

FRONT WHEEL/SUSPENSION/STEERING

Tighten the steering stem nut to the specified torque.

TORQUE: 103 N·m (10.5 kgf·m, 76 lbf·ft)

Move the steering stem right and left, lock-to-lock, several times.

Make sure the steering stem moves smoothly without play or binding.

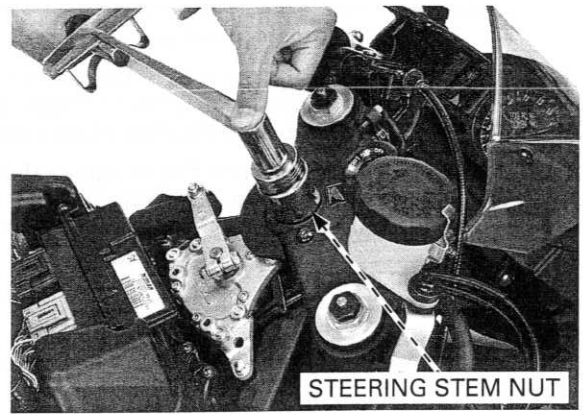

STEERING STEM NUT

Install the steering stem cap.

Connect the ignition switch 2P (Brown) connector.

Install the wire clamp and tighten the bolt securely.

Route the wires properly (page 1-21).

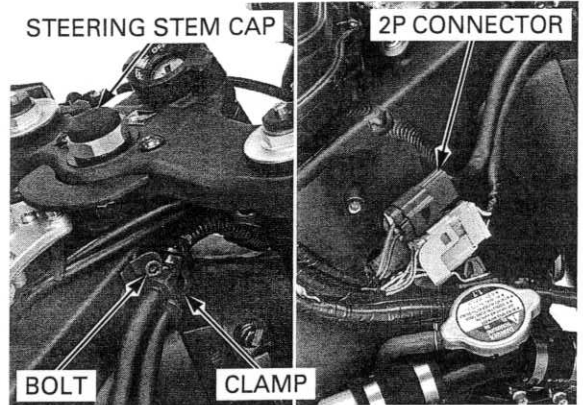

STEERING STEM CAP

2P CONNECTOR

BOLT

CLAMP

Connect the second arm to the top bridge and tighten the nut to the specified torque.

TORQUE: 12 N·m (1.2 kgf·m, 9 lbf·ft)

Install the following:

- Front wheel (page 14-21)
- Upper inner cowls (page 3-7)
- Fuel tank cover (page 3-9)
- Front fender (page 3-13)

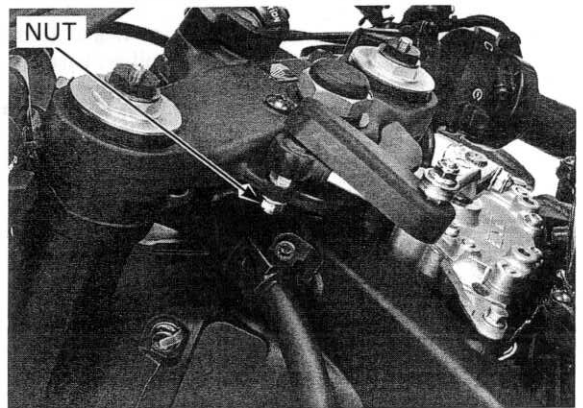

NUT

STEERING HEAD BEARING PRE-LOAD

Jack up the motorcycle to raise the front wheel off the ground.

Position the steering stem to the straight ahead position.

Hook a spring scale to the fork slider and measure the steering head bearing pre-load.

Standard: 14.7 – 17.7 N (1.5 – 1.8 kgf)

Make sure that there is no cable or wire harness interference.

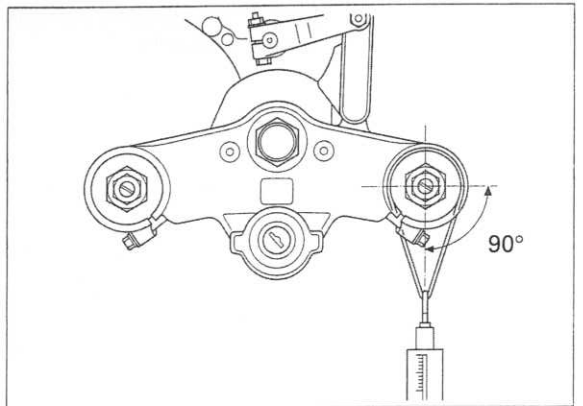

90°

If the readings do not fall within the standard value, disconnect the second arm and recheck.

Standard: 10.8 – 12.7 N (1.1 – 1.3 kgf)

If the readings do not fall within the standard value, adjust the steering stem adjusting nut (page 14-34).

If the readings fall within the standard value, check the HESD (page 14-8).

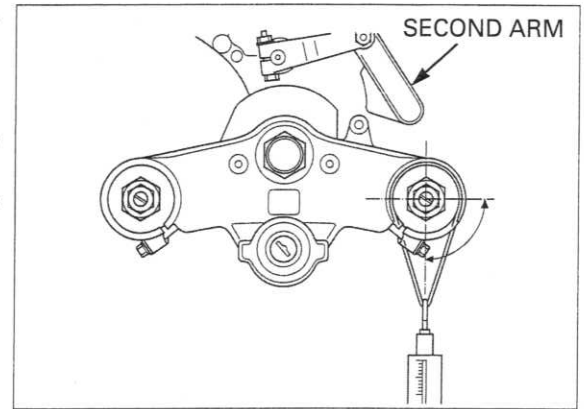

MEMO

15. REAR WHEEL/SUSPENSION

COMPONENT LOCATION	15-2	SHOCK ABSORBER.....	15-14
SERVICE INFORMATION	15-3	SUSPENSION LINKAGE	15-19
TROUBLESHOOTING	15-6	SWINGARM.....	15-20
REAR WHEEL.....	15-7		

REAR WHEEL/SUSPENSION

COMPONENT LOCATION

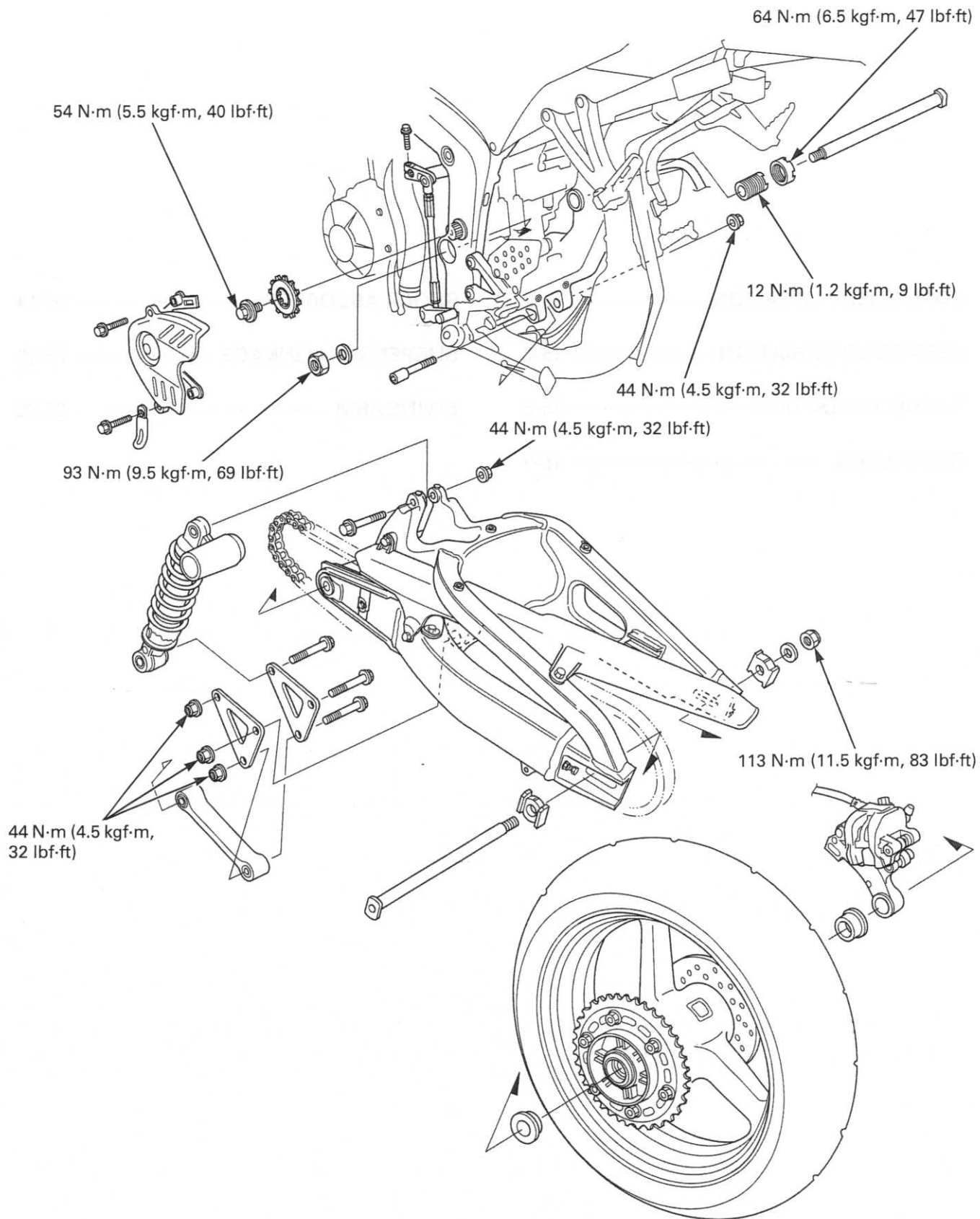

SERVICE INFORMATION

GENERAL

- A contaminated brake disc or pad reduces stopping power. Discard contaminated pads and clean a contaminated disc with a high quality brake degreasing agent.
- After the rear wheel installation, check the brake operation by applying the brake pedal.
- The shock absorber contains nitrogen under high pressure. Do not allow fire or heat near the shock absorber.
- Before disposal of the shock absorber, release the nitrogen (page 15-18).
- When servicing the rear wheel and suspension, support the motorcycle using a safety stand or hoist.
- Use only tires marked "TUBELESS" and tubeless valves on rim marked "TUBELESS TIRE APPLICABLE".
- Use genuine Honda replacement bolts and nuts for all suspension pivot and mounting point.
- When installing the swingarm, be sure to tighten the swingarm pivot fasteners to the specified torque in the specified sequence. If you mistake the tightening torque or sequence, loosen all pivot fasteners, then tighten them again to the specified torque in the correct sequence.
- For brake system information (page 16-4).
- When using the lock nut wrench for the swingarm pivot lock nut, use a deflecting beam type torque wrench 20 inches long. The lock nut wrench increases the torque wrench's leverage, so the torque wrench reading will be less than the torque actually applied to the lock nut. The specification given is the actual torque applied to the lock nut, not the reading on the torque wrench. Do not overtighten the lock nut, The specification later in the text gives both actual and indicated.

SPECIFICATIONS

Unit: mm (in)



ITEM		STANDARD	SERVICE LIMIT
Minimum tire tread depth		—	2.0 (0.08)
Cold tire pressure	Driver only	290 kPa (2.90 kgf/cm ² , 42 psi)	—
	Driver and passenger	290 kPa (2.90 kgf/cm ² , 42 psi)	—
Axle runout		—	0.2 (0.01)
Wheel rim runout	Radial	—	2.0 (0.08)
	Axial	—	2.0 (0.08)
Wheel balance weight		—	60 g (2.1 oz) max.
Drive chain	Size/link	DID	DID525HV KAI-112YB
		RK	RK525ROZ6-112LJFZ
	Slack	30 – 40 (1.2 – 1.6)	—
Shock absorber	Spring pre-load adjuster standard position		Position 2
	Rebound damping adjuster initial setting		2-1/2 turns out from full hard
	Compression damping adjuster initial setting		22 clicks out from full hard

TORQUE VALUES





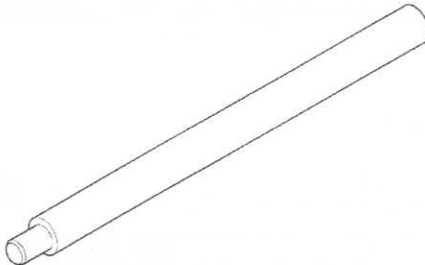
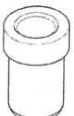
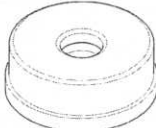

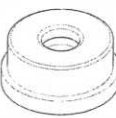
Rear brake disc bolt	42 N·m (4.3 kgf·m, 31 lbf·ft)	ALOC bolt; replace with a new one
Driven sprocket nut	64 N·m (6.5 kgf·m, 47 lbf·ft)	U-nut
Rear axle nut	113 N·m (11.5 kgf·m, 83 lbf·ft)	U-nut
Shock absorber mounting nut	44 N·m (4.5 kgf·m, 32 lbf·ft)	U-nut
Shock link nut	44 N·m (4.5 kgf·m, 32 lbf·ft)	U-nut
Shock arm-to-swingarm nut	44 N·m (4.5 kgf·m, 32 lbf·ft)	U-nut
Drive chain slider bolt	9.0 N·m (0.9 kgf·m, 6.6 lbf·ft)	ALOC bolt; replace with a new one
Drive chain case bolt	12 N·m (1.2 kgf·m, 9 lbf·ft)	
Swingarm pivot nut	93 N·m (9.5 kgf·m, 69 lbf·ft)	
Swingarm pivot adjusting bolt	12 N·m (1.2 kgf·m, 9 lbf·ft)	Apply oil to the threads
Swingarm pivot lock nut	64 N·m (6.5 kgf·m, 47 lbf·ft)	
Drive sprocket bolt	54 N·m (5.5 kgf·m, 40 lbf·ft)	

REAR WHEEL/SUSPENSION

TOOLS

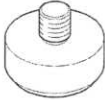
<p>Bearing remover shaft 07GGD-0010100</p> 	<p>Bearing remover head, 25 mm 07746-0050800</p> 	<p>Driver 07749-0010000</p> 
<p>Driver 07949-3710001</p> 	<p>Driver shaft 07946-MJ00100 or 07946-MJ0A100 (U.S.A. only)</p> 	<p>Driver head 07946-MJ00201</p> 
<p>Attachment, 42 x 47 mm 07746-0010300</p> 	<p>Attachment, 52 x 55 mm 07746-0010400</p> 	<p>Attachment, 24 x 26 mm 07746-0010700</p> 
<p>Attachment, 22 x 24 mm 07746-0010800 or 07746-001A800 (U.S.A. only)</p> 	<p>Attachment 40 x 42 mm 07746-0010900</p> 	<p>Attachment, 28 x 30 mm 07946-1870100</p> 

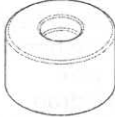
REAR WHEEL/SUSPENSION

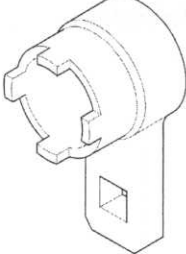
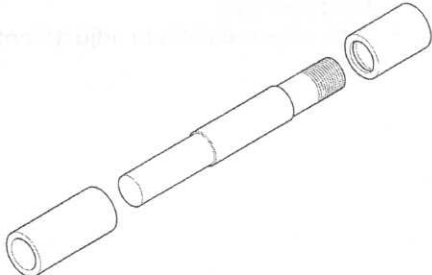
<p>Pilot, 17 mm 07746-0040400</p> 	<p>Pilot, 20 mm 07746-0040500</p> 	<p>Pilot, 25 mm 07746-0040600</p> 
<p>Pilot, 28 mm 07746-0041100</p> 	<p>Pilot, 28 mm 07JAD-PH80400</p> 	<p>Attachment, 37 mm 07ZMD-MBW0200</p> 
<p>Attachment, 30 mm I.D. 07746-0030300</p> 	<p>Lock nut wrench 07908-4690003</p> 	<p>Bearing driver 07GMD-KT80100</p> 

REAR WHEEL/SUSPENSION

TROUBLESHOOTING

Soft suspension

- Weak shock absorber spring
- Incorrect suspension adjustment
- Oil leakage from damper unit
- Insufficient tire pressure

Hard suspension

- Incorrect suspension adjustment
- Damaged rear suspension pivot bearings
- Bent damper rod
- Bent swingarm pivot
- Tire pressure too high

Rear wheel wobbling

- Bent rim
- Worn or damaged rear wheel bearings
- Faulty rear tire
- Unbalanced rear tire and wheel
- Insufficient rear tire pressure
- Faulty swingarm pivot bearings

Rear wheel turns hard

- Faulty rear wheel bearings
- Bent rear axle
- Rear brake drag
- Drive chain too tight

Rear suspension noise

- Faulty rear shock absorber
- Loose rear suspension fasteners
- Worn rear suspension pivot bearings

Steers to one side or does not track straight

- Bent rear axle
- Axle alignment/chain adjustment not equal on both sides

REAR WHEEL

REMOVAL

Remove the screw and brake hose clamp.

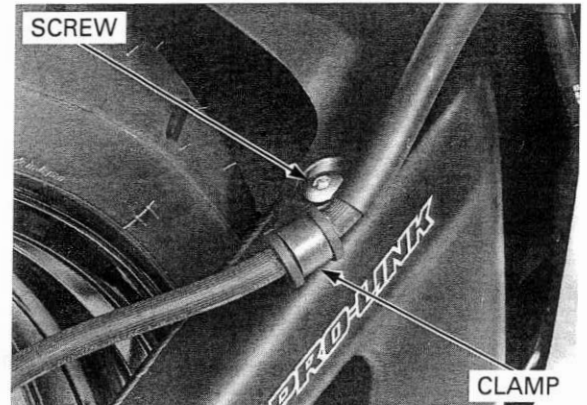

Support the motorcycle securely, raise the rear wheel off the ground.

Fully slacken the drive chain (page 4-24).

Remove the rear axle nut, washer and adjusting plate.

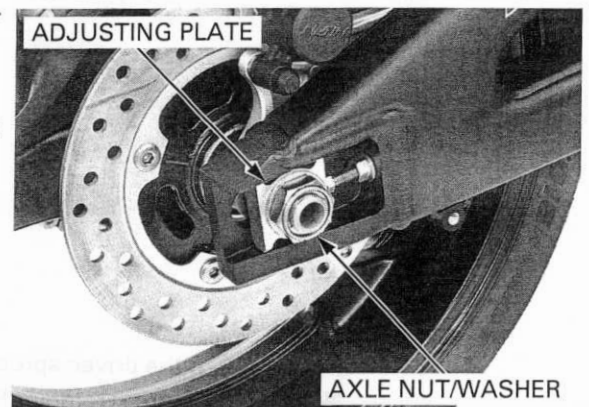

Push the rear wheel forward.
Remove the rear axle and adjusting plate.

Derail the drive chain from the driven sprocket.

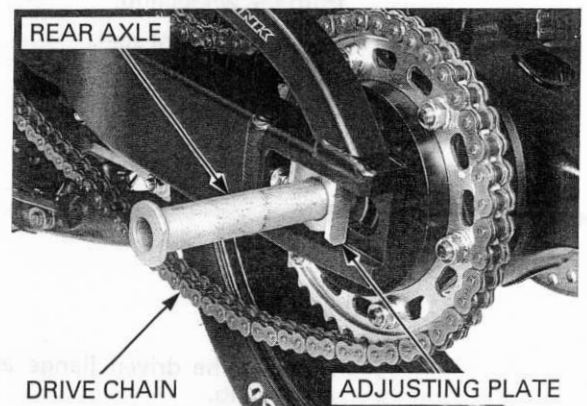

Do not hang the caliper by the brake hose. Do not twist the brake hose. Do not operate the brake pedal after removing the rear wheel.

Remove the rear brake caliper bracket and rear wheel.

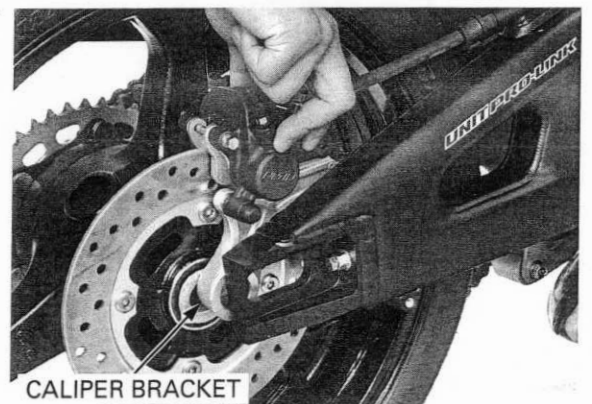

REAR WHEEL/SUSPENSION

Remove the side collars.

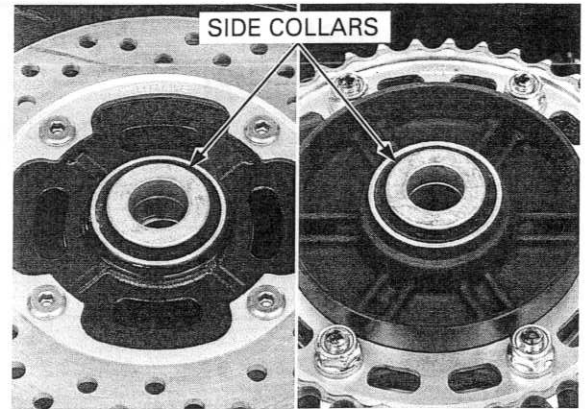

DISASSEMBLY

Remove the bolts and brake disc.
Remove the right dust seal.

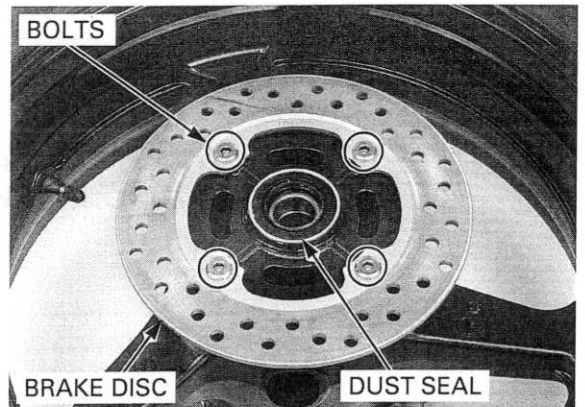

If you replace the driven sprocket, loosen the driven sprocket nuts before removing the driven flange from the wheel hub.

Remove the dust seal.

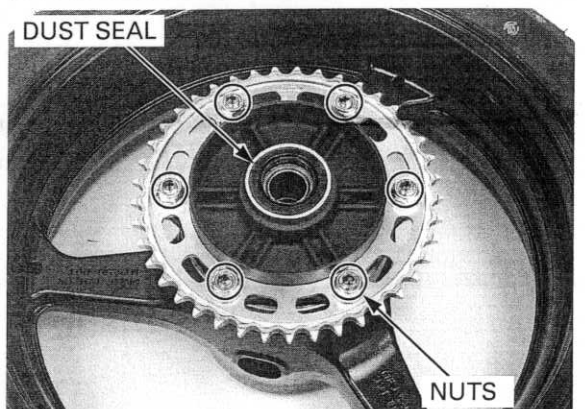

Remove the driven flange assembly from the left wheel hub.

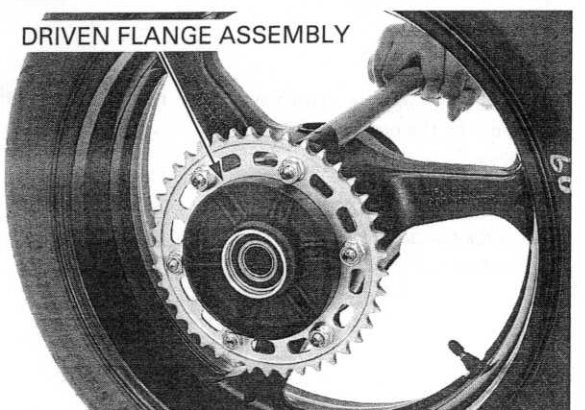

If you replace the driven sprocket, remove the nuts, washers, driven sprocket and bolts.

DRIVEN SPROCKET

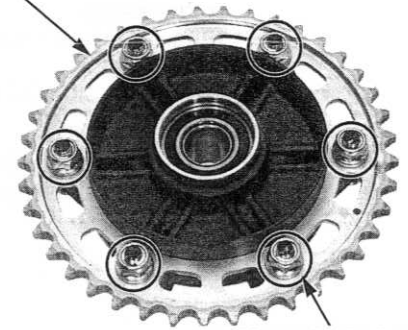

NUTS/WASHERS/BOLTS

Remove the wheel rubber dampers.
Remove the O-ring.

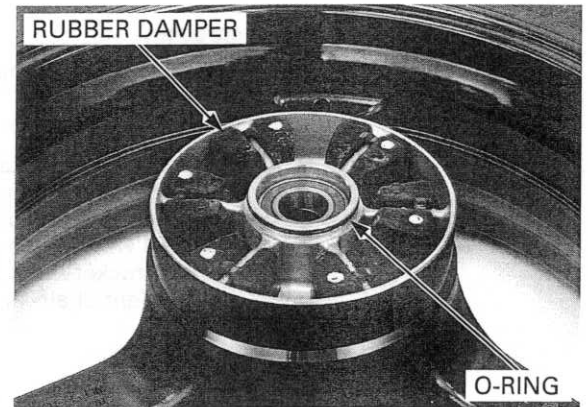

INSPECTION

Axle

Place the axle on V-blocks and measure the runout. Actual runout is 1/2 the total indicator reading.

SERVICE LIMIT: 0.2 mm (0.01 in)

Wheel balance

For wheel balance servicing (page 14-18).

- When checking wheel balance, install the brake disc onto the wheel (page 15-12).

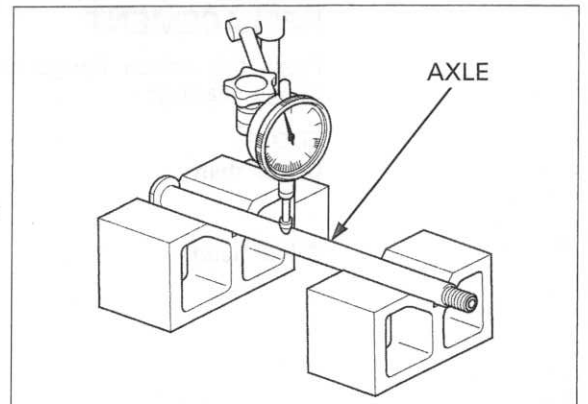

Wheel/driven flange bearings

Turn the inner race of each bearing with your finger. The bearings should turn smoothly and quietly. Also check that the outer race of the bearing fits tightly in the hub or driven flange.

Replace the wheel bearings in pairs.

Replace the bearings if the races do not turn smoothly, quietly, or if the outer race fit loosely in the hub or driven flange.

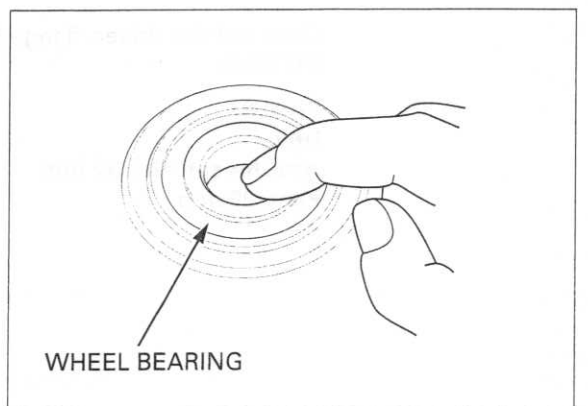

REAR WHEEL/SUSPENSION

Wheel rim runout

Check the rim runout by placing the wheel in a truing stand. Spin the wheel slowly and read the runout using a dial indicator. Actual runout is 1/2 the total indicator reading.

SERVICE LIMITS:

Radial: 2.0 mm (0.08 in)

Axial: 2.0 mm (0.08 in)

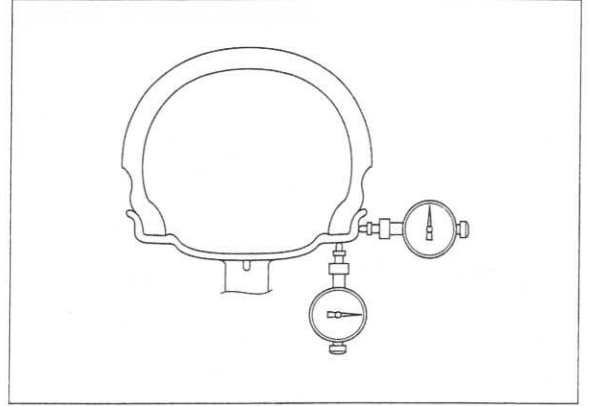

Driven sprocket

Check the condition of the final driven sprocket teeth. Replace the sprocket if worn or damaged.

- If the final driven sprocket requires replacement, inspect the drive chain and drive sprocket.
- Never install a new drive chain on a worn sprocket or a worn chain on new sprockets. Both chain and sprocket must be in good condition or the replacement chain or sprocket will wear rapidly.

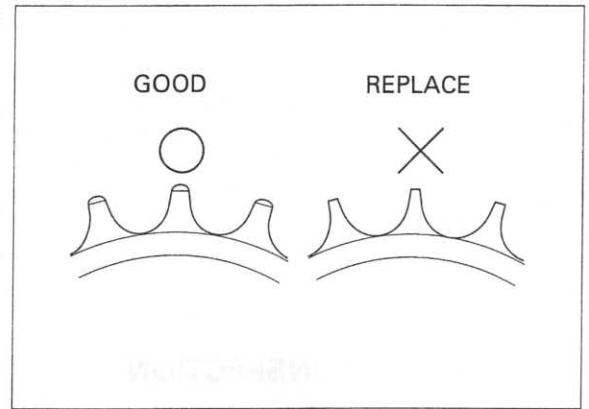

DRIVEN FLANGE BEARING REPLACEMENT

Press the driven flange collar out of the driven flange bearings.

TOOLS:

Driver shaft

Driver head

07946-MJ00100 or
07946-MJ0A100
(U.S.A. only)
07946-MJ00201

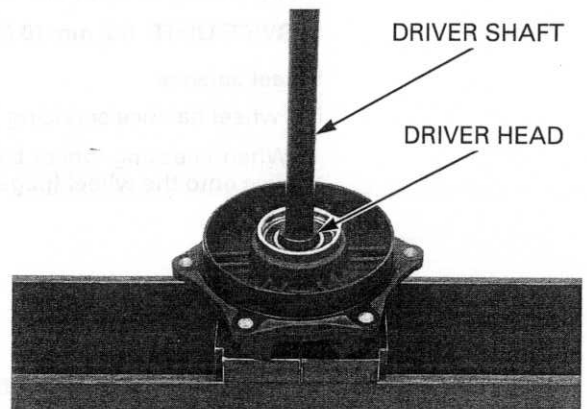

Drive out the driven flange bearings using the special tools.

TOOLS:

Driver

Attachment, 40 x 42 mm

Pilot, 28 mm

07749-0010000
07746-0010900
07JAD-PH80400

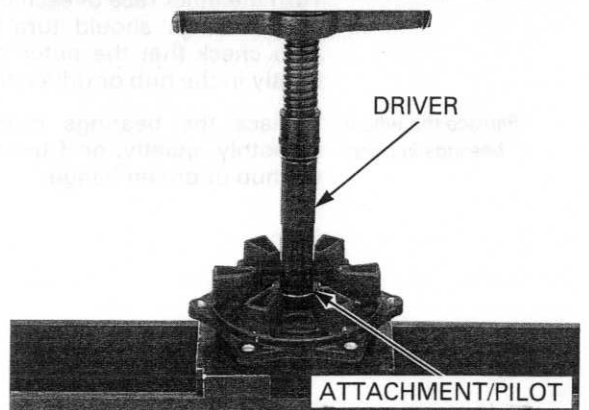

Press the driven flange collar into the new driven flange bearings until it is fully seated.

TOOLS:

- | | |
|-------------------------------|----------------------|
| Driver | 07749-0010000 |
| Attachment, 28 x 30 mm | 07946-1870100 |
| Pilot, 25 mm | 07746-0040600 |

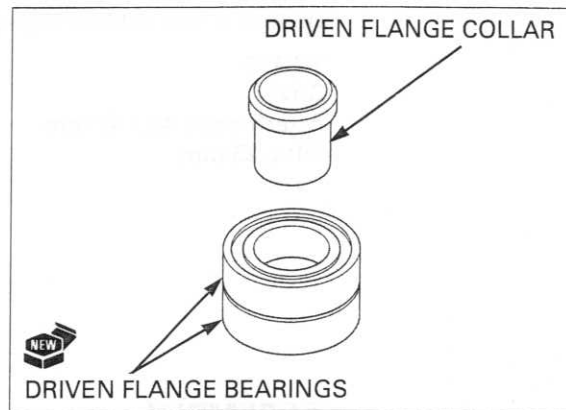

Press the driven flange bearings/collar into the driven flange using the special tools.

TOOLS:

- | | |
|-------------------------------|----------------------|
| Driver | 07749-0010000 |
| Attachment, 52 x 55 mm | 07746-0010400 |
| Pilot, 25 mm | 07746-0040600 |

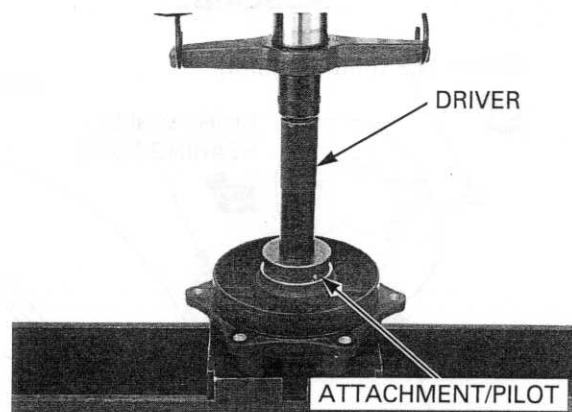

WHEEL BEARING REPLACEMENT

Install the bearing remover head into the bearing. From the opposite side, install the bearing remover shaft and drive the bearing out of the wheel hub. Remove the distance collar and drive out the other bearing.

TOOLS:

- | | |
|------------------------------------|----------------------|
| Bearing remover head, 25 mm | 07746-0050800 |
| Bearing remover shaft | 07GGD-0010100 |

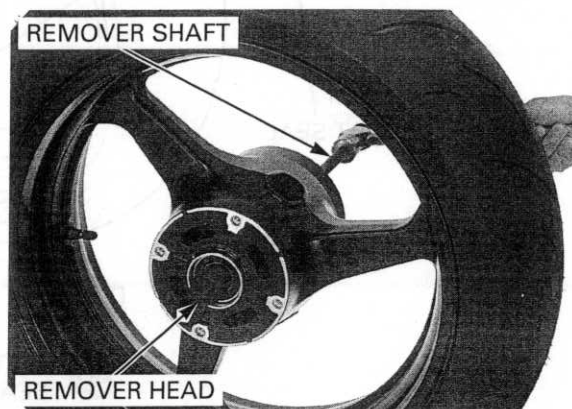

Never install the old bearings, once the bearings has been removed, the bearings must be replaced with new ones.

Drive in a new right bearing squarely until it is fully seated.

TOOLS:

- | | |
|-------------------------------|----------------------|
| Driver | 07749-0010000 |
| Attachment, 52 x 55 mm | 07746-0010400 |
| Pilot, 25 mm | 07746-0040600 |

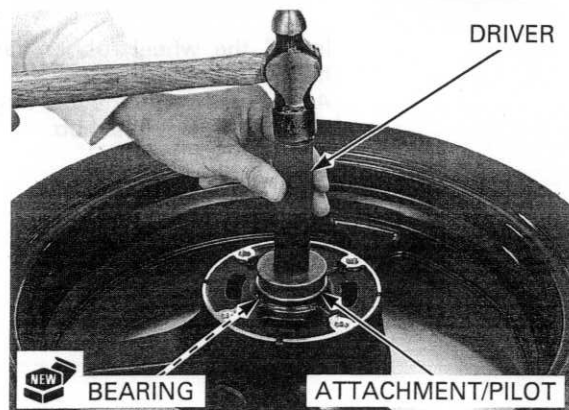

REAR WHEEL/SUSPENSION

Install the distance collar.
Drive in a new left bearing squarely.

TOOLS:

- Driver 07749-0010000
- Attachment, 42 x 47 mm 07746-0010300
- Pilot, 25 mm 07746-0040600

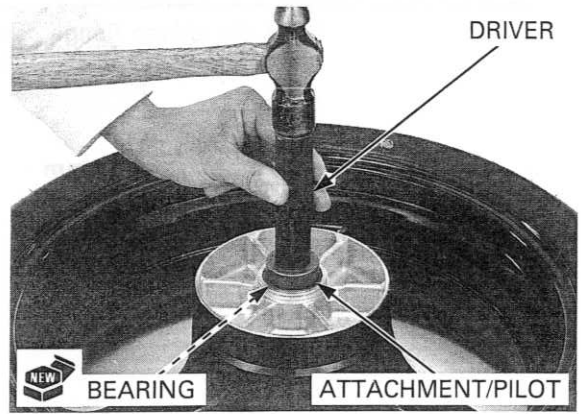

ASSEMBLY

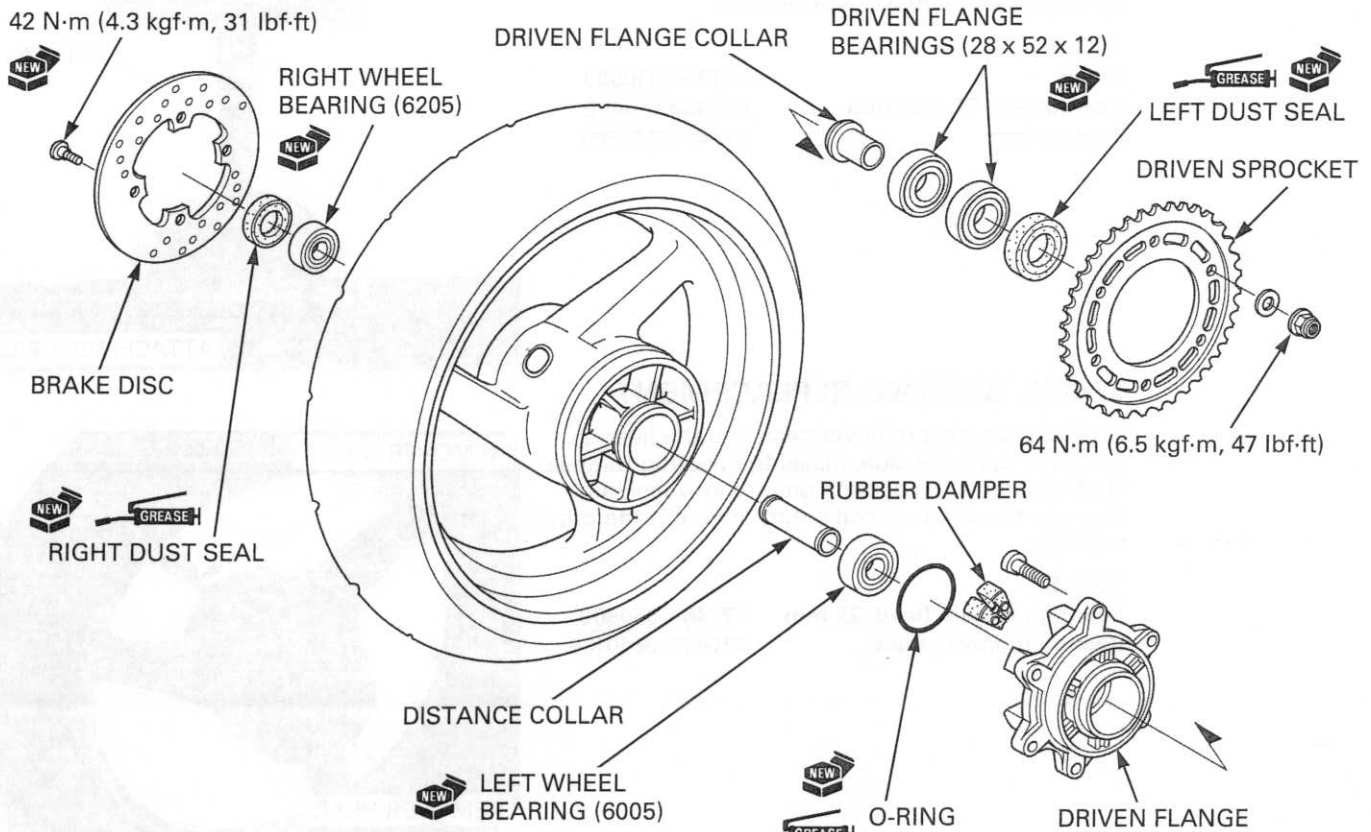

Install the wheel rubber dampers into the wheel hub.
Apply grease to a new O-ring and install it into the groove of the wheel hub.

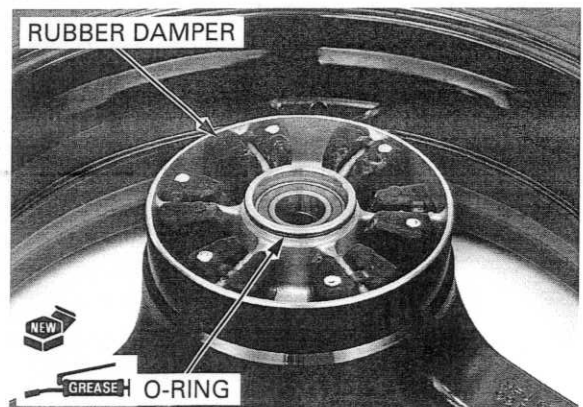

If the driven sprocket is removed, install the driven sprocket bolts, sprocket, washers and nuts onto the driven flange.

Install the driven flange assembly into the left wheel hub.

If the driven sprocket is removed, tighten the driven sprocket nuts to the specified torque.

TORQUE: 64 N·m (6.5 kgf·m, 47 lbf·ft)

Apply grease to a new dust seal lip, then install it into the driven flange.

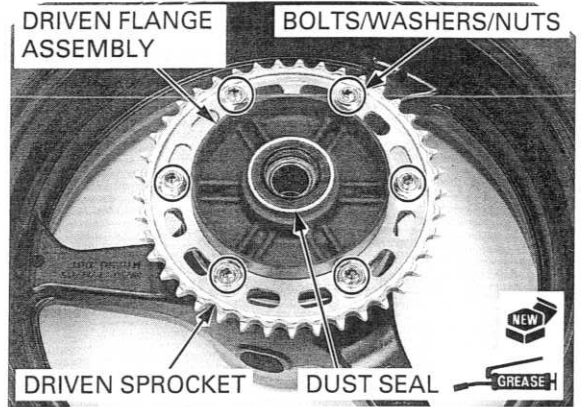

Install the brake disc with its rotating direction mark facing out.

Tighten new brake disc bolts to the specified torque.

TORQUE: 42 N·m (4.3 kgf·m, 31 lbf·ft)

Apply grease to a new dust seal lip, then install it into the wheel hub.

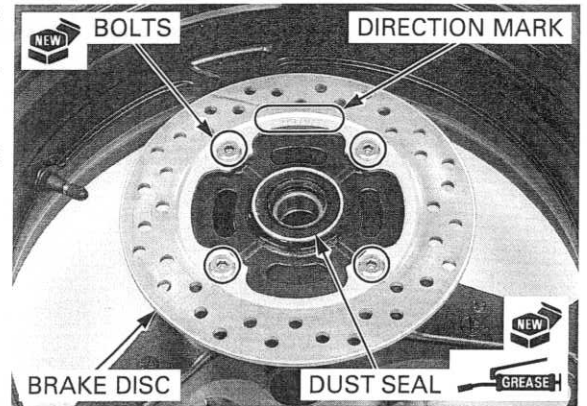

INSTALLATION

Install the side collars.

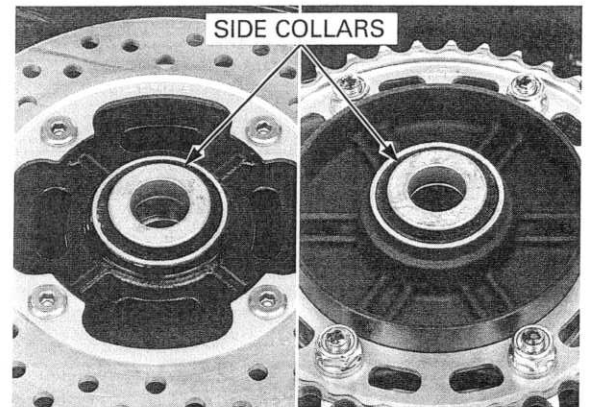

Be careful not to damage the brake pads. Install the rear brake caliper bracket onto the guide rail of the swingarm while placing the rear wheel into the swingarm.

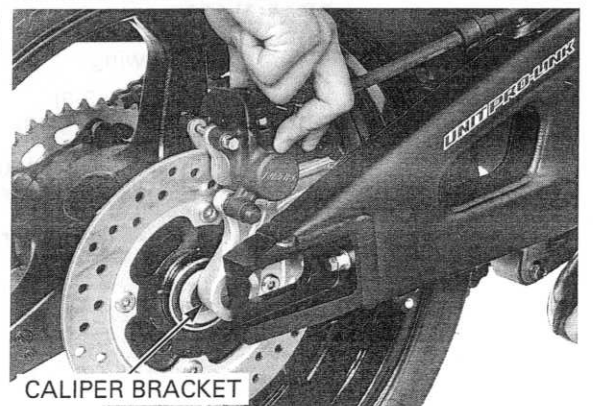

REAR WHEEL/SUSPENSION

Install the drive chain over the driven sprocket.

Apply a thin coat of grease to the rear axle surface.
Install the adjusting plate and rear axle from the left side.

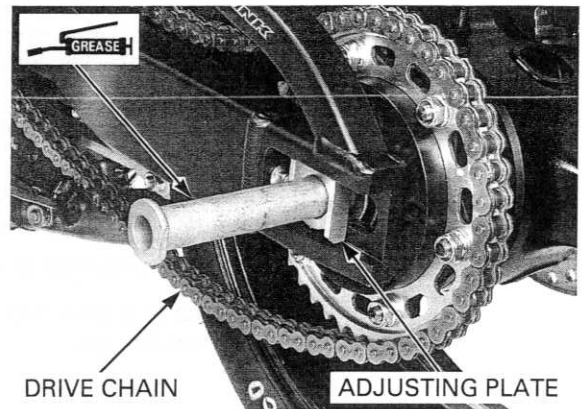

Install the adjusting plate, washer and rear axle nut.
Adjust the drive chain slack (page 4-24).

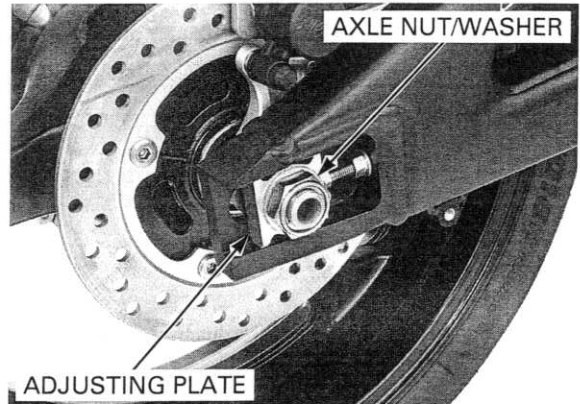

Install the brake hose clamp between rear fender C and swingarm, aligning its tab with the swingarm hole.

Tighten the screw securely.

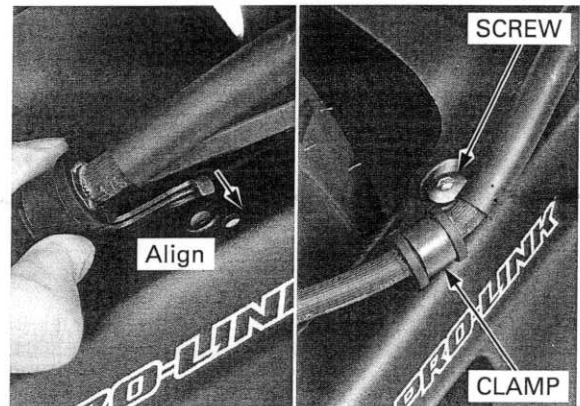

SHOCK ABSORBER

REMOVAL

Remove the following:

- Lower cowl (page 3-6)
- Rear fender C (page 3-16)

Support the motorcycle using a hoist or equivalent, and rise the rear wheel off the ground.

Support the rear wheel securely.

Remove the shock absorber lower mounting nut and bolt.

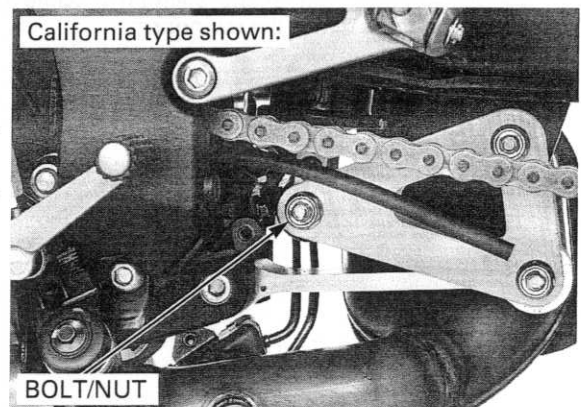

Remove the shock absorber upper mounting nut and bolt, then remove the shock absorber upward.

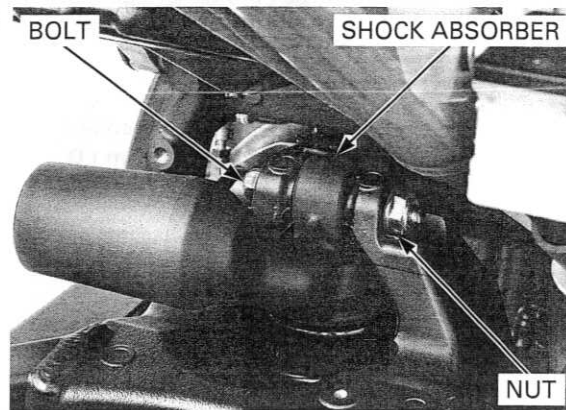

INSPECTION

Visually inspect the shock absorber for damage.

Check the following:

- Damper rod for bends or damage
- Damper unit for deformation or oil leaks
- Rubber bumper for wear or damage

Inspect all the other parts for wear or damage. If necessary, replace the shock absorber as an assembly.

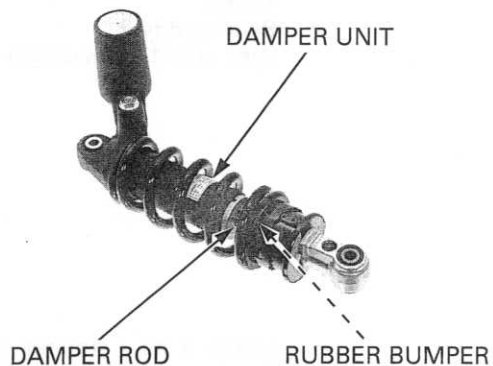

UPPER BEARING REPLACEMENT

Remove the dust seals.

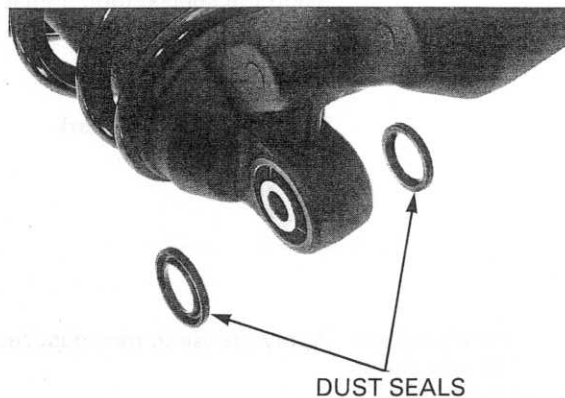

Press the spherical bearing to get the clearance necessary to remove the stopper ring using the special tool.

TOOL:
Bearing driver
 (Use only 17 mm collar)

07GMD-KT80100

Remove the stopper ring.

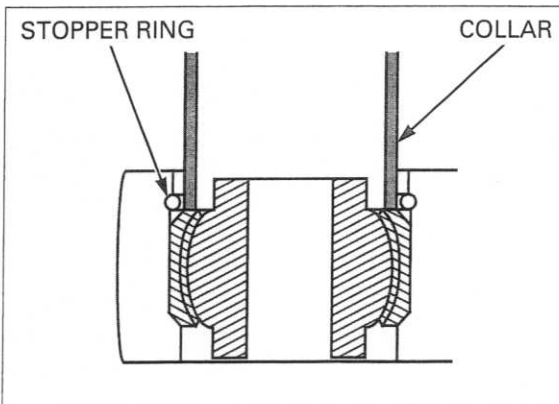

REAR WHEEL/SUSPENSION

Press the spherical bearing out of the upper mount using the special tools.

TOOLS:

Bearing driver
 (Use only 17 mm collar)
Attachment, 30 mm I.D.

07GMD-KT80100
07746-0030300

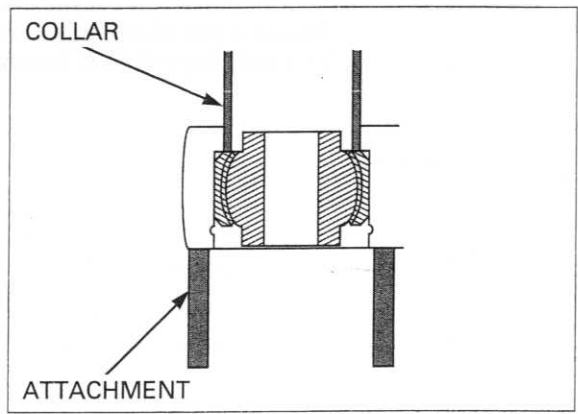

Drive the bearing in evenly; do not allow it to tilt.

Press a new spherical bearing into the upper mount using the special tool.

TOOL:

Bearing driver
 (Use only 17 mm collar)

07GMD-KT80100

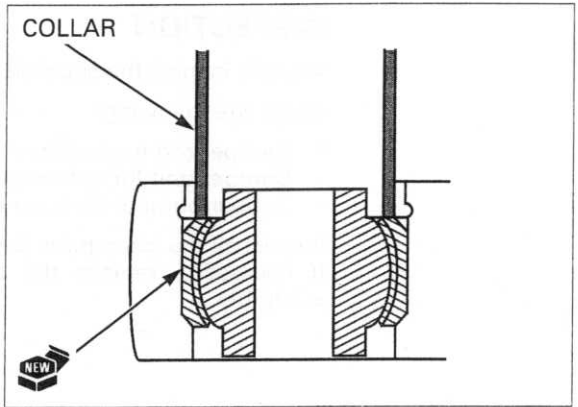

Install a new stopper ring into the groove of the upper mount securely. Press the spherical bearing into the upper mount using the special tool, until it seats against the stopper ring.

TOOL:

Bearing driver
 (Use only 17 mm collar)

07GMD-KT80100

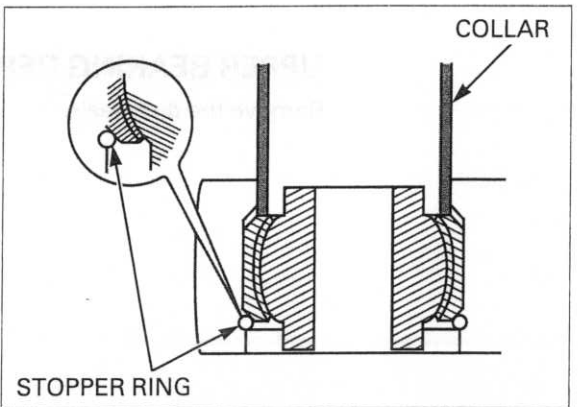

The left dust seal O.D. is larger than right dust seal O.D.

Apply grease to new dust seal lips and install them.

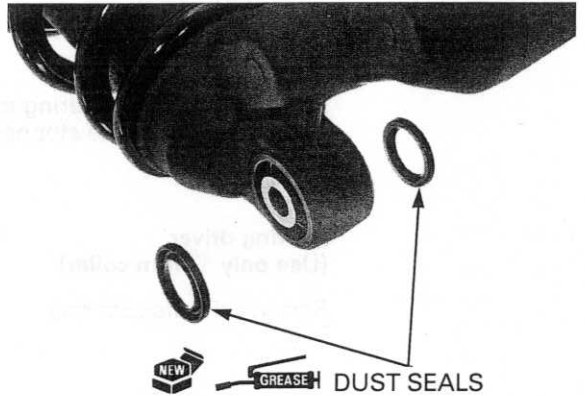

LOWER BEARING REPLACEMENT

Remove the dust seals and collar.

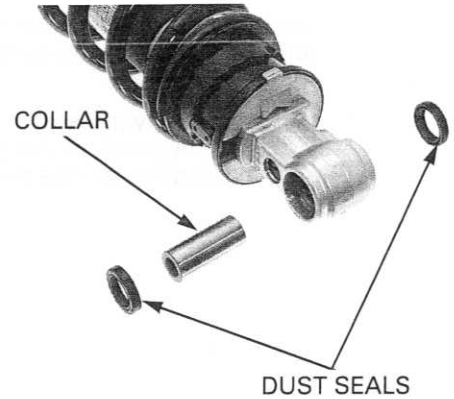

Press the needle bearing out of the lower mount using the special tools.

TOOLS:

- | | |
|-------------------------------|---------------|
| Driver | 07949-3710001 |
| Attachment, 22 x 24 mm | 07746-0010800 |
| Pilot, 17 mm | 07746-0040400 |
| Attachment, 30 mm I.D. | 07746-0030300 |

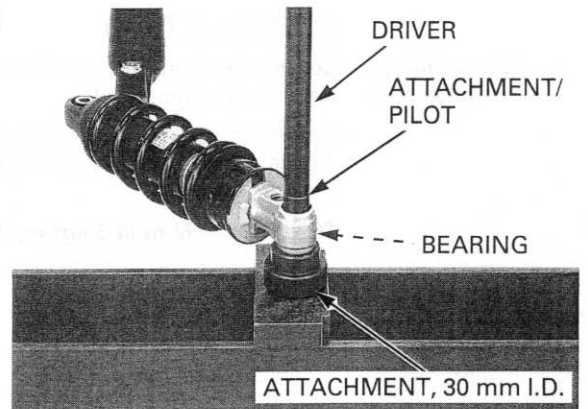

Pack a new needle bearing with multi-purpose grease.

Press the needle bearing into the lower mount using the special tools.

TOOLS:

- | | |
|-------------------------------|---------------|
| Driver | 07949-3710001 |
| Attachment, 22 x 24 mm | 07746-0010800 |
| Pilot, 17 mm | 07746-0040400 |

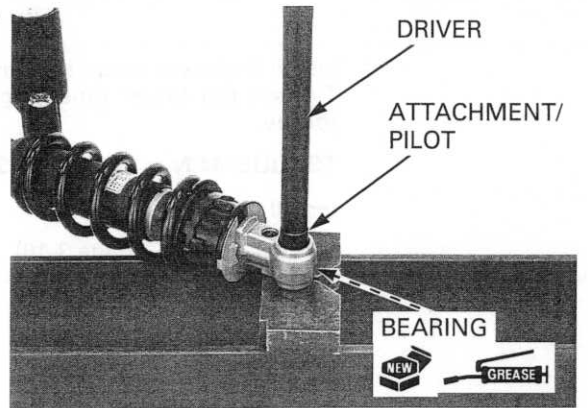

Apply grease to new dust seal lips.
Install the collar and new dust seals.

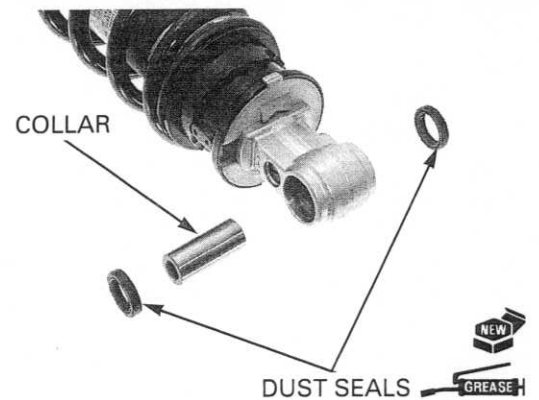

REAR WHEEL/SUSPENSION

SHOCK ABSORBER DISPOSAL PROCEDURE

Release the nitrogen from the reservoir by pushing and dropping the reservoir cap packing with the 2 mm (0.07 in) shaft.

- Put on safety glasses.
- Before disposal of the shock absorber, release the nitrogen from the reservoir.

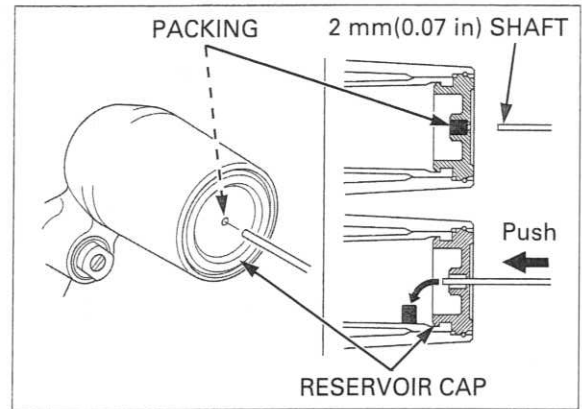

INSTALLATION

Support the rear wheel securely.

Set the shock absorber with the compression damping adjuster facing left.

Install the upper mounting bolt.
Tighten the upper mounting nut to the specified torque.

TORQUE: 44 N·m (4.5 kgf·m, 32 lbf·ft)

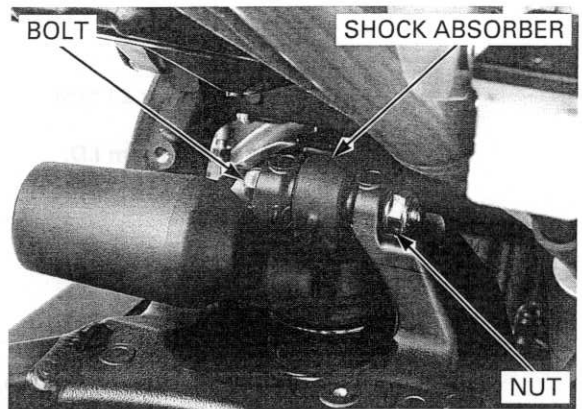

Install the lower mounting bolt.
Tighten the lower mounting nut to the specified torque.

TORQUE: 44 N·m (4.5 kgf·m, 32 lbf·ft)

Install the following:

- Rear fender C (page 3-16)
- Lower cowl (page 3-6)

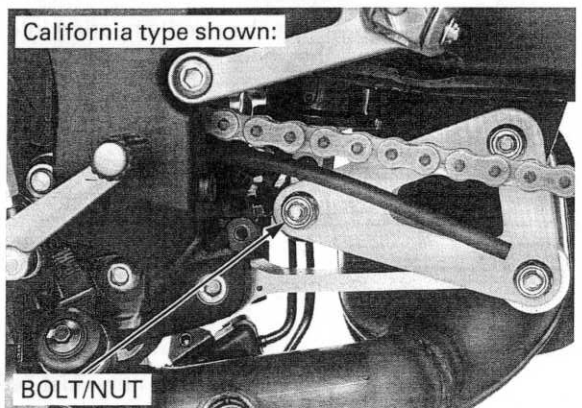

SUSPENSION LINKAGE

REMOVAL

Remove the lower cowl (page 3-6).

Support the motorcycle using a hoist or equivalent, and raise the rear wheel off the ground.

Support the rear wheel securely.

Remove the following:

- Shock link bolts/nuts
- Shock link
- Shock arm

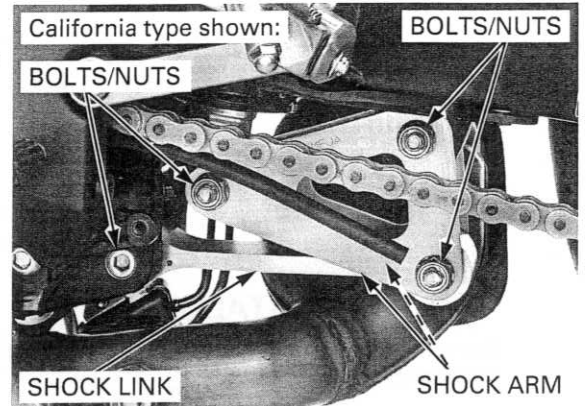

SHOCK LINK BEARING REPLACEMENT

Remove the pivot collar and dust seals.

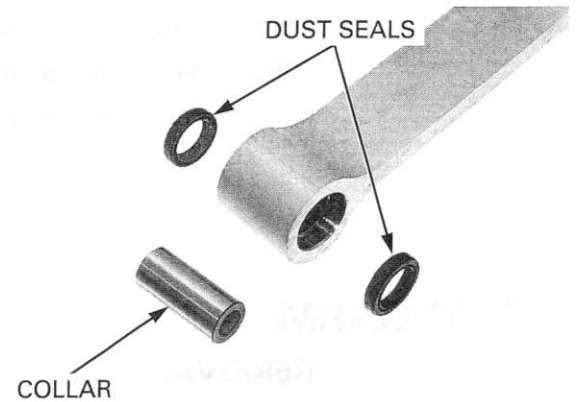

Press the needle bearings out of the shock link using the special tools.

TOOLS:

Driver
Attachment, 22 x 24 mm

07949-3710001
 07746-0010800 or
 07746-001A800
 (U.S.A. only)
 07746-0040400
 07746-0030300

Pilot, 17 mm
Attachment, 30 mm I.D.

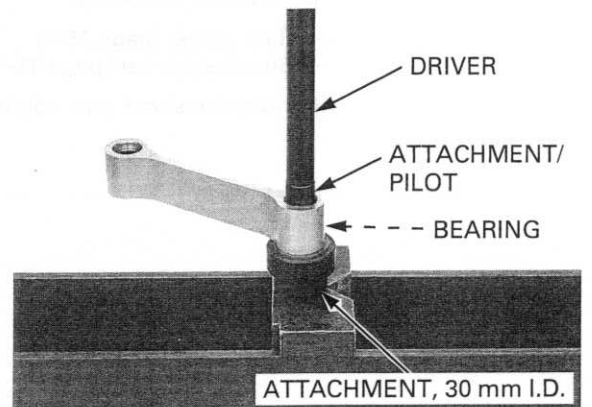

Press the needle bearing into the shock link with the marked side facing out.

Pack new needle bearings with multi-purpose grease.

Press the needle bearings into the shock link so that the needle bearing surface is 5.2 – 5.7 mm (0.20 – 0.22 in) below the end of the shock link using the special tools.

TOOLS:

Driver
Attachment, 22 x 24 mm

07949-3710001
 07746-0010800 or
 07746-001A800
 (U.S.A. only)
 07746-0040400

Pilot, 17 mm

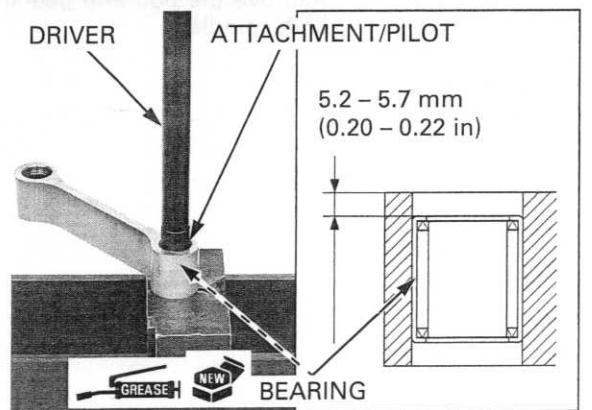

REAR WHEEL/SUSPENSION

Apply grease to new dust seal lips, then install the dust seals and collar into the shock link.

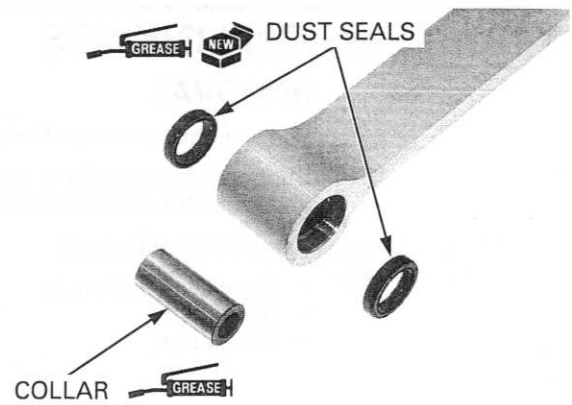

INSTALLATION

Support the rear wheel securely.

Loosely install the following:

- Shock arm
- Shock link
- Shock link bolts/nuts

Tighten the nuts to the specified torque.

TORQUE: 44 N·m (4.5 kgf·m, 32 lbf·ft)

Install the lower cowl (page 3-6).

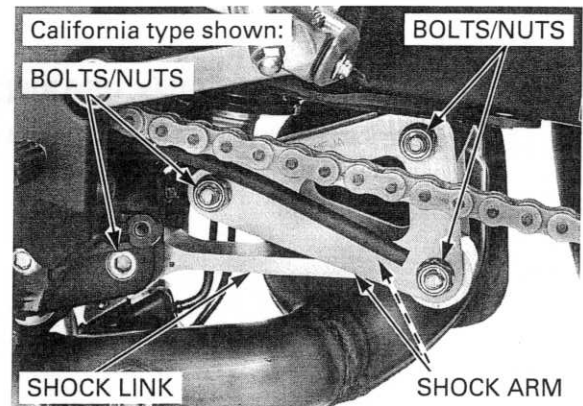

SWINGARM

REMOVAL

Remove the following:

- Rear wheel (page 15-7)
- Shock absorber (page 15-14)

Remove the shock arm bolt/nut (swingarm side).

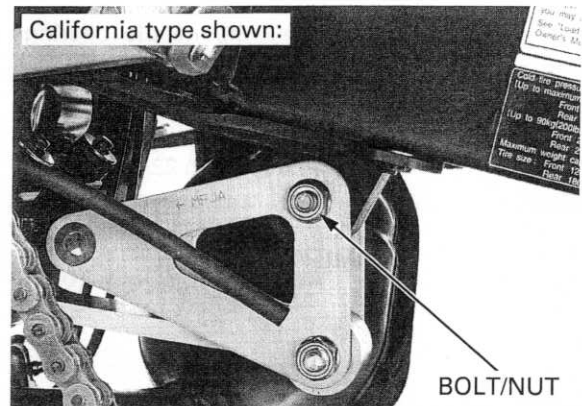

Remove the bolt and gearshift arm from the gearshift spindle.

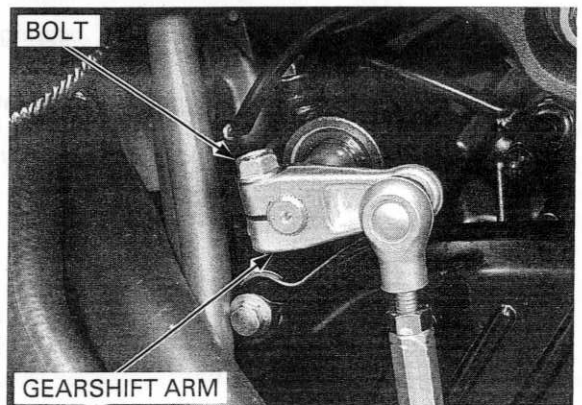

Remove the bolts, wire clamp, drive sprocket cover and guide plate.

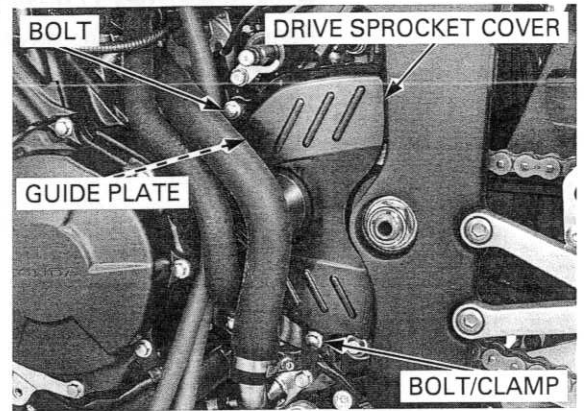

Remove the bolt, washer and drive sprocket.

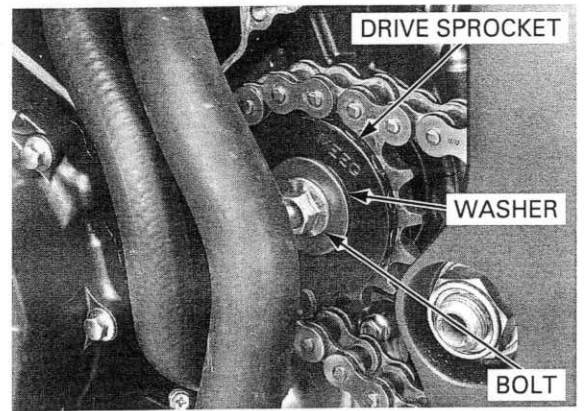

Remove the swingarm pivot nut and washer.

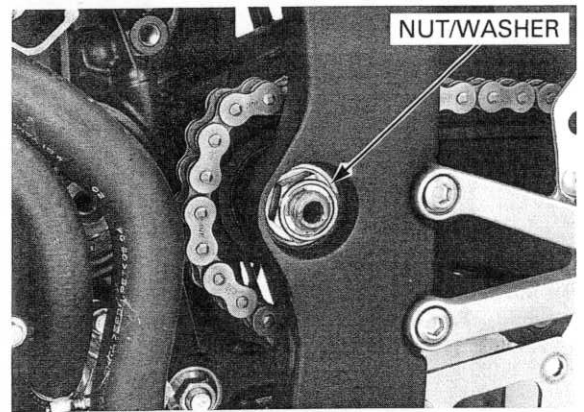

Loosen the swingarm pivot lock nut using the special tool.

TOOL:

Lock nut wrench

07908-4690003

Turn the swingarm pivot adjusting bolt counter-clockwise fully by turning the swingarm pivot bolt.

Remove the pivot bolt, lock nut, adjusting bolt and swingarm.

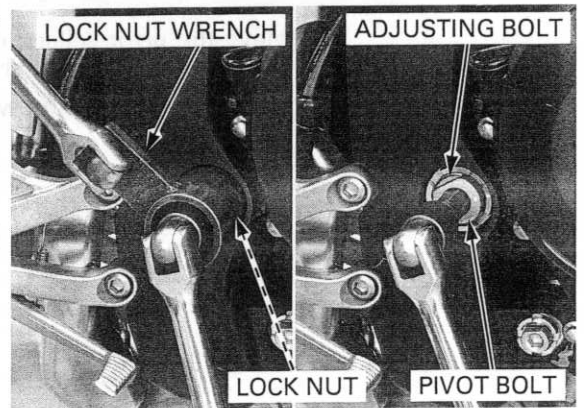

REAR WHEEL/SUSPENSION

DISASSEMBLY/INSPECTION

Remove the bolts and drive chain case.

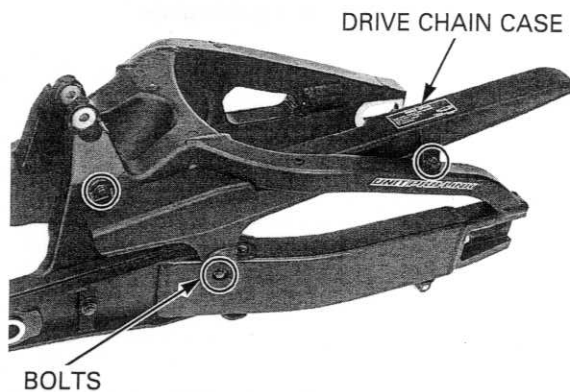

Remove the bolts, washers and drive chain slider.
Check the drive chain slider for wear or damage.

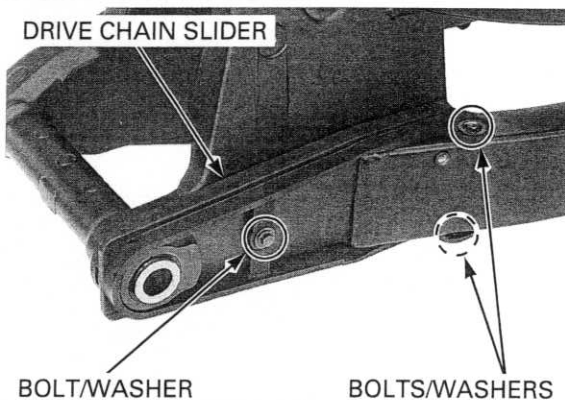

Remove the dust seals and collar from the swingarm.
Check the collar for wear or damage.

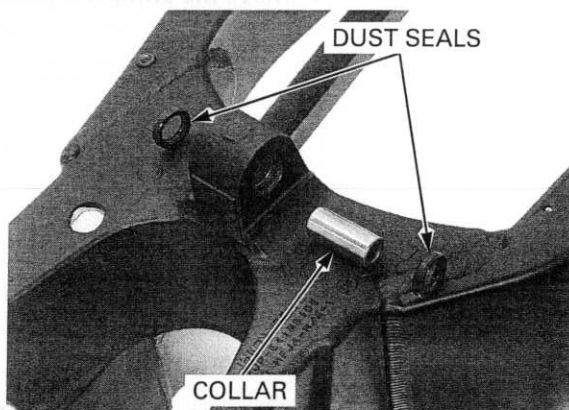

Remove the pivot collars, dust seals and distance collar from the swingarm pivot.
Check the pivot collars for wear or damage.

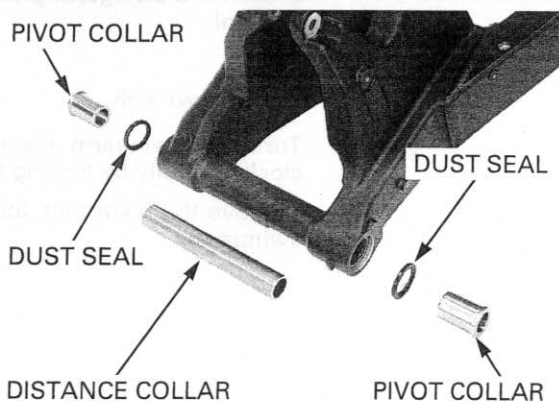

Turn the inner race of right side pivot ball bearing with your finger.
The bearing should turn smoothly and quietly. Also check that the bearing outer race fits tightly in the swingarm pivot.

Remove and discard the bearing if the races do not turn smoothly and quietly, or if they fit loosely in the swingarm pivot.

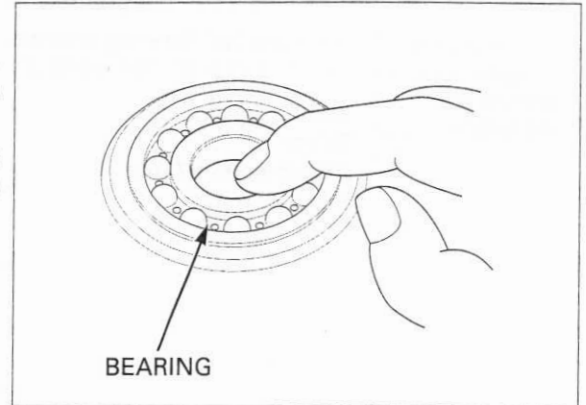

Pivot bearing replacement

Right side: Remove the snap ring from the swingarm right side pivot.

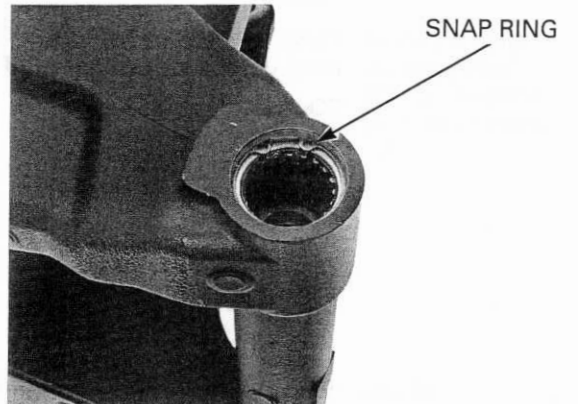

Right side: Press the right pivot needle and ball bearings out of the swingarm pivot using the special tools.

TOOLS:

Driver	07949-3710001
Attachment, 24 x 26 mm	07746-0010700
Pilot, 20 mm	07746-0040500

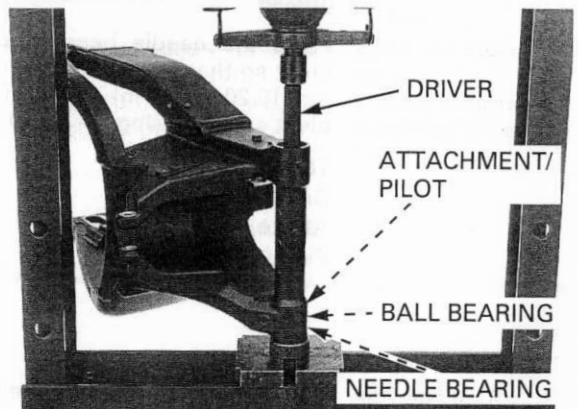

Left side: Press the left pivot needle bearing out of the swingarm pivot using the special tools.

TOOLS:

Driver	07949-3710001
Attachment, 28 x 30 mm	07946-1870100

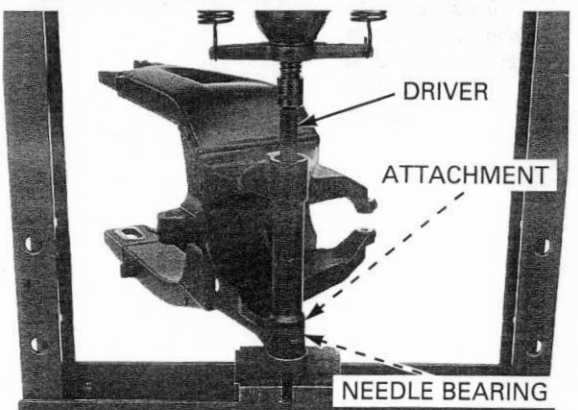

REAR WHEEL/SUSPENSION

Right side: Pack a new ball bearing with multi-purpose grease.

Press the ball bearing into the swingarm right pivot until it is fully seated using the special tools.

TOOLS:

Driver
Attachment, 37 mm
Pilot, 20 mm

07749-0010000
07ZMD-MBW0200
07746-0040500

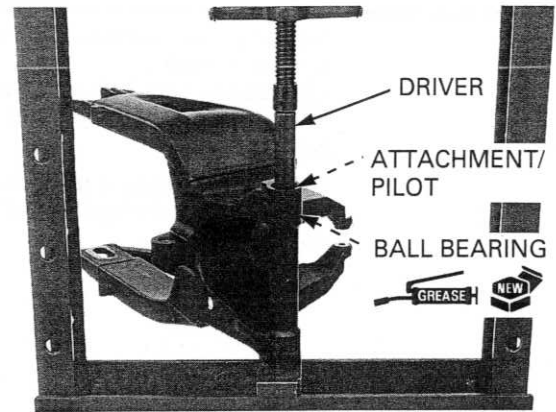

Right side: Pack a new needle bearing with multi-purpose grease.

Press the needle bearing into the swingarm right pivot until it seats using the special tools.

TOOLS:

Driver
Attachment, 37 mm
Pilot, 28 mm

07749-0010000
07ZMD-MBW0200
07746-0041100

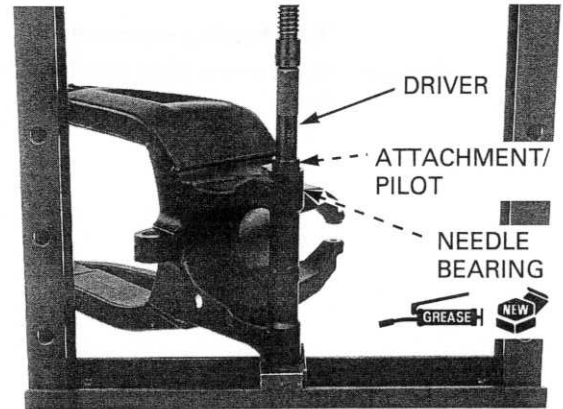

Left side: Pack a new needle bearing with multi-purpose grease.

Press the needle bearing into the swingarm left pivot so that the needle bearing surface is 5.0 – 6.0 mm (0.20 – 0.24 in) below the end of the swingarm pivot surface using the special tools.

TOOLS:

Driver
Attachment, 37 mm
Pilot, 28 mm

07749-0010000
07ZMD-MBW0200
07746-0041100

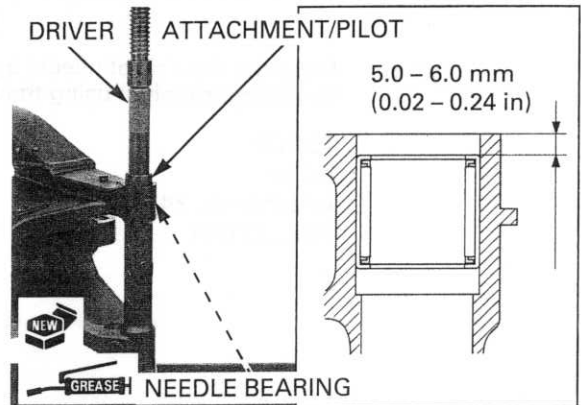

Right side: After installing a snap ring, always rotate it in its groove to be sure it is fully seated.

Install the snap ring into the groove securely.

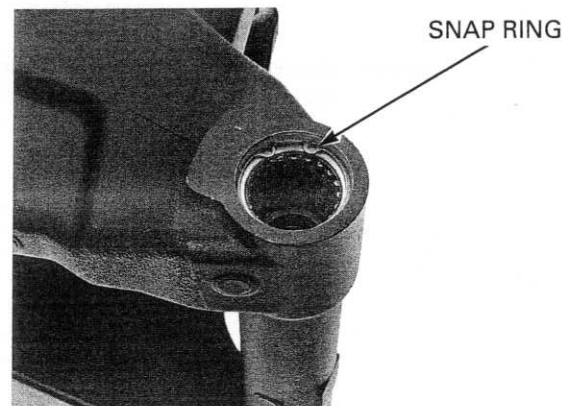

SHOCK ARM-TO-SWINGARM BEARING REPLACEMENT

Press the needle bearing out of the swingarm using the special tools.

TOOLS:

Driver
Attachment, 22 x 24 mm

07949-3710001
07746-0010800 or
07746-001A800
(U.S.A. only)
07746-0040400
07746-0030300

Pilot, 17 mm
Attachment, 30 mm I.D.

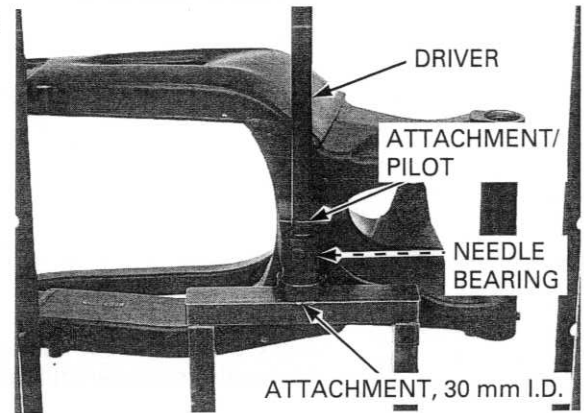

Pack a new needle bearing with multi-purpose grease.

Press the needle bearing into the swingarm so that the needle bearing surface is 5.5 – 6.0 mm (0.22 – 0.24 in) below the end of the swingarm using the special tools.

TOOLS:

Driver
Attachment, 22 x 24 mm

07949-3710001
07746-0010800 or
07746-001A800
(U.S.A. only)
07746-0040400

Pilot, 17 mm

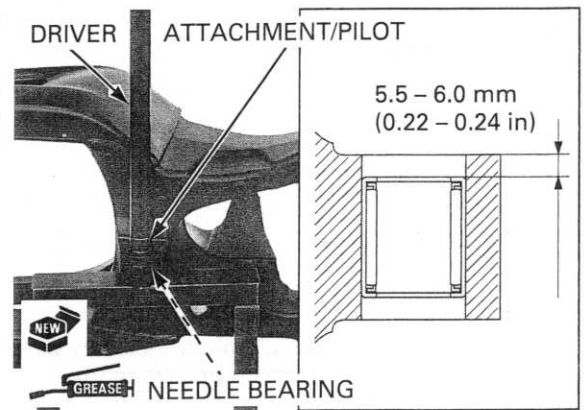

ASSEMBLY

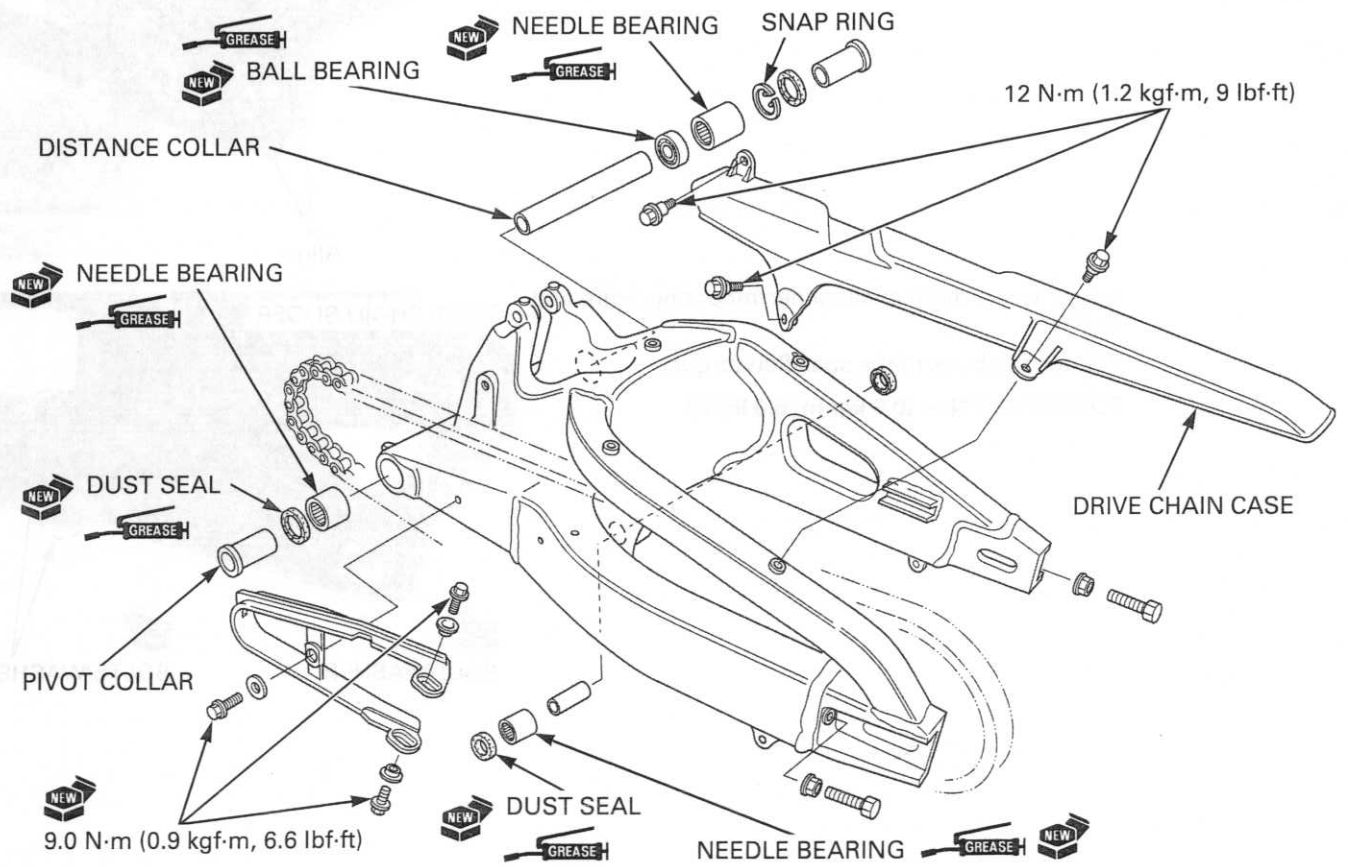

REAR WHEEL/SUSPENSION

Apply grease to new dust seal lips.

Install the distance collar, dust seals and pivot collars to the swingarm.

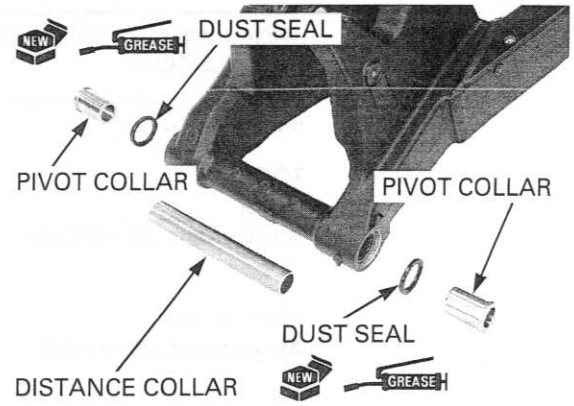

Apply grease to new dust seal lips, then install the dust seals and collar into the swingarm.

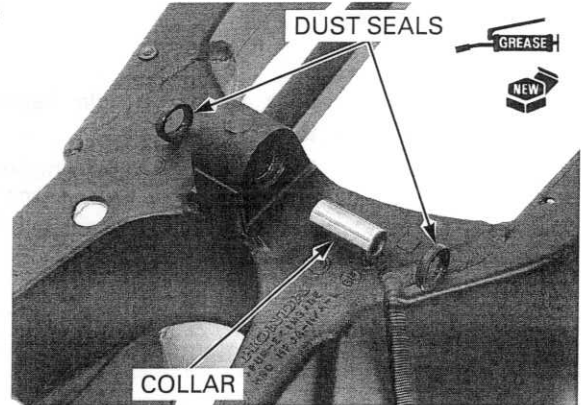

Install the drive chain slider aligning its slit with the boss on the swingarm.

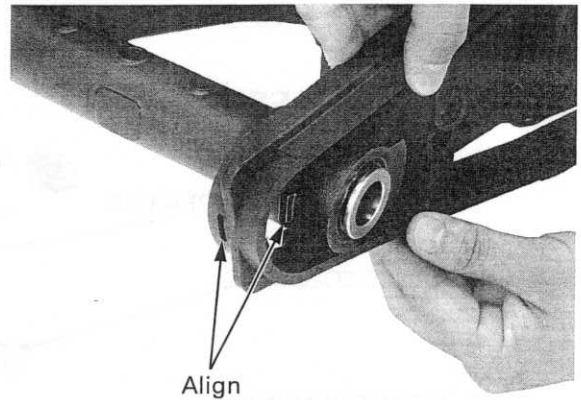

Install a new drive chain slider mounting bolts and washers.

Tighten the bolts to the specified torque.

TORQUE: 9.0 N·m (0.9 kgf·m, 6.6 lbf·ft)

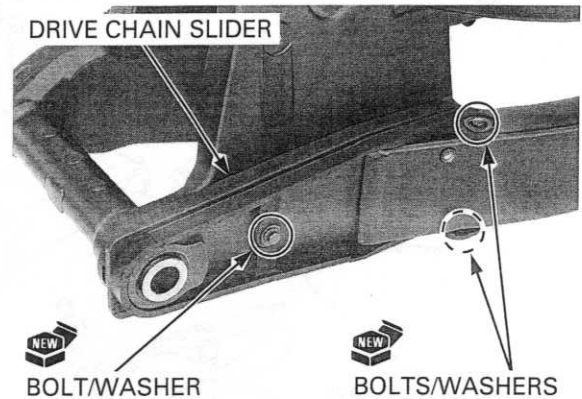

Install the drive chain case, and tighten the bolts to the specified torque.

TORQUE: 12 N·m (1.2 kgf·m, 9 lbf·ft)

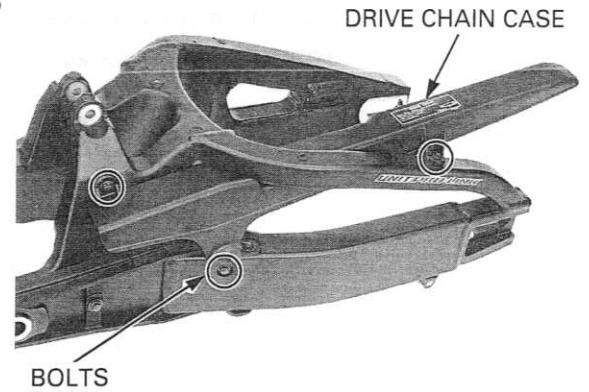

INSTALLATION

Apply oil to the swingarm pivot adjusting bolt threads and install it to the frame.

Make sure that the swingarm pivot adjusting bolt does not protrude from the inside pivot.

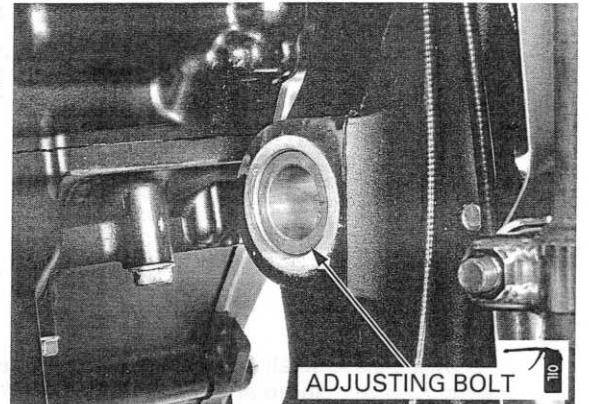

Apply grease to the swingarm pivot bolt.

Install the swingarm and pivot bolt to the frame.

Loosely install the swingarm pivot lock nut.

Tighten the swingarm pivot adjusting bolt to the specified torque by turning the swingarm pivot bolt.

TORQUE: 12 N·m (1.2 kgf·m, 9 lbf·ft)

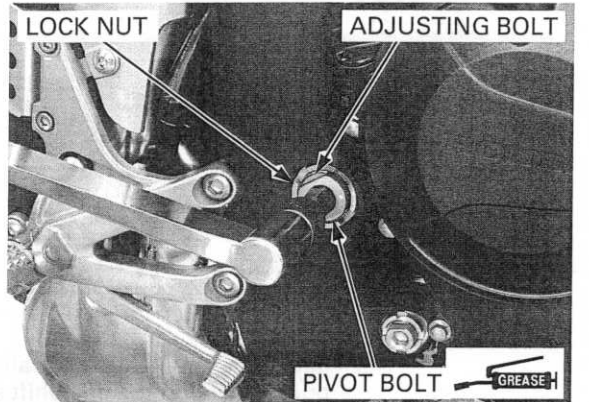

Hold the swingarm pivot bolt and tighten the swingarm pivot lock nut using the special tool.

TOOL:

Lock nut wrench **07908-4690003**

TORQUE:

Actual: 64 N·m (6.5 kgf·m, 47 lbf·ft)

Indicated: 58 N·m (5.9 kgf·m, 43 lbf·ft)

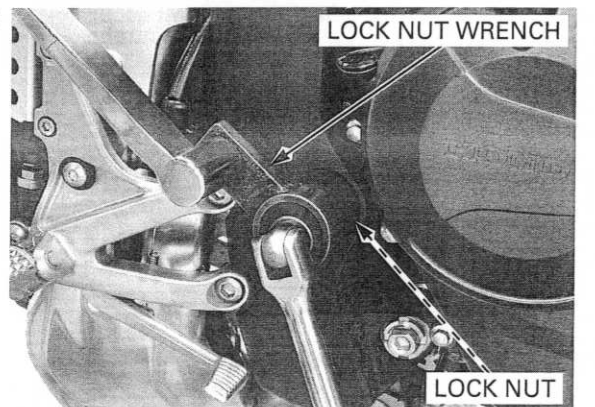

REAR WHEEL/SUSPENSION

Install the washer and swingarm pivot nut.
Tighten the nut to the specified torque.
TORQUE: 93 N·m (9.5 kgf·m, 69 lbf·ft)

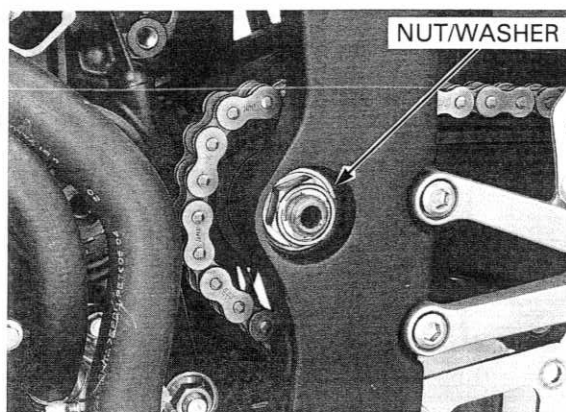

Install the drive sprocket with its marks facing out.
Install the washer and bolt, then tighten the bolt to the specified torque.
TORQUE: 54 N·m (5.5 kgf·m, 40 lbf·ft)

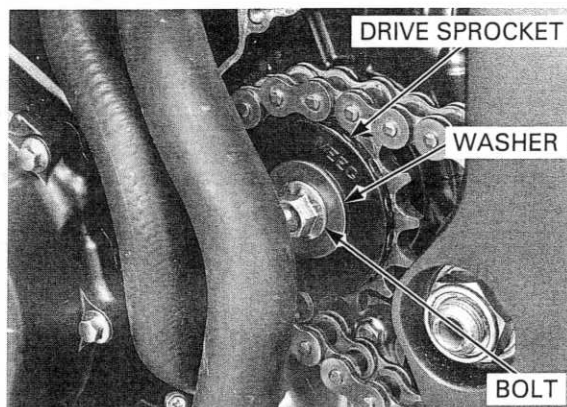

Route the sidestand switch wire properly (page 1-21).

Install the guide plate, drive sprocket cover, wire clamp and bolts, then tighten the bolts securely.

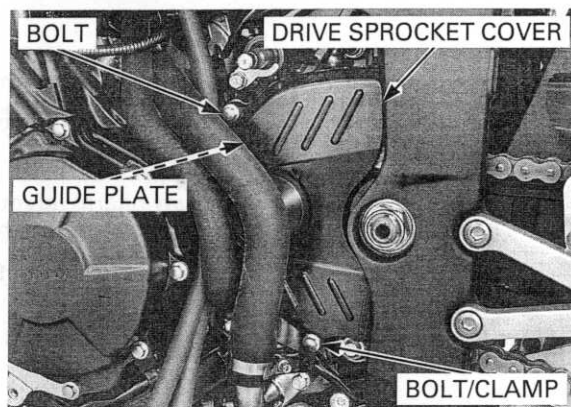

Install the gearshift arm aligning its slit with the punch mark on the gearshift spindle.
Tighten the bolt securely.

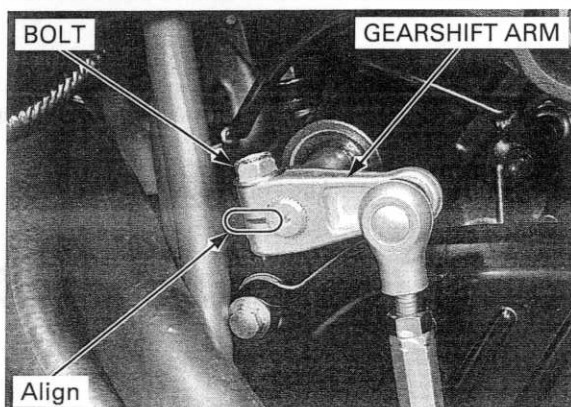

Install the shock arm bolt/nut (swingarm side) and tighten the nut to the specified torque.

TORQUE: 44 N·m (4.5 kgf·m, 32 lbf·ft)

Install the following:

- Shock absorber (page 15-18)
- Rear wheel (page 15-13)

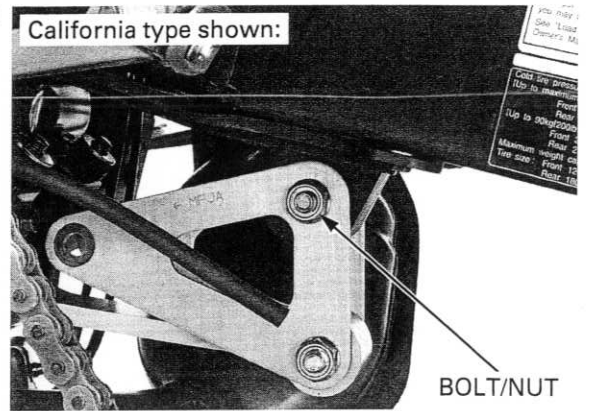

MEMO

16. HYDRAULIC BRAKE

COMPONENT LOCATION	16-2	FRONT MASTER CYLINDER.....	16-13
SERVICE INFORMATION	16-4	REAR MASTER CYLINDER	16-19
TROUBLESHOOTING	16-6	FRONT BRAKE CALIPERS	16-25
BRAKE FLUID REPLACEMENT/ AIR BLEEDING	16-7	REAR BRAKE CALIPER	16-28
BRAKE PAD/DISC.....	16-9	BRAKE PEDAL	16-31

HYDRAULIC BRAKE

COMPONENT LOCATION

FRONT:

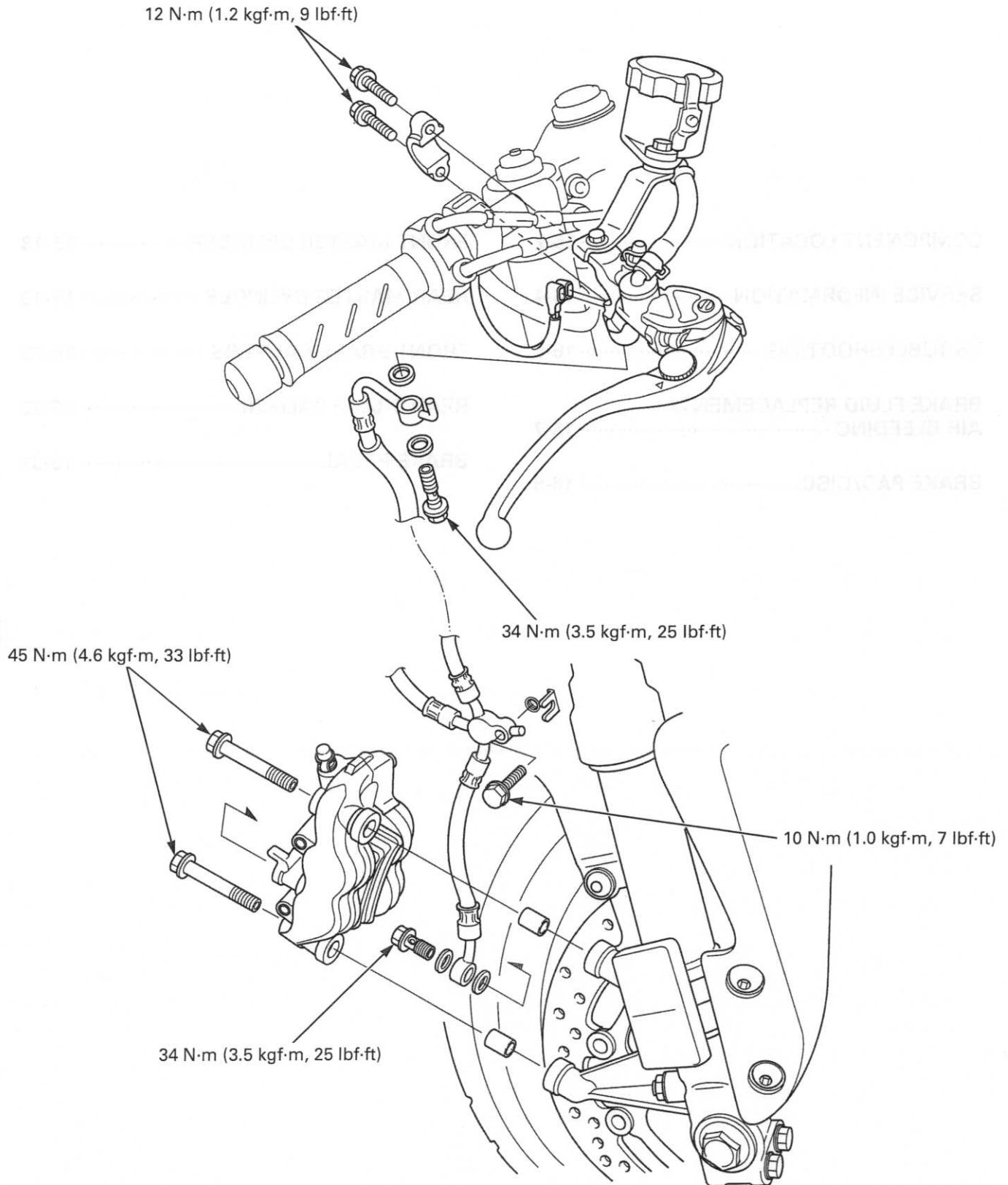

REAR:

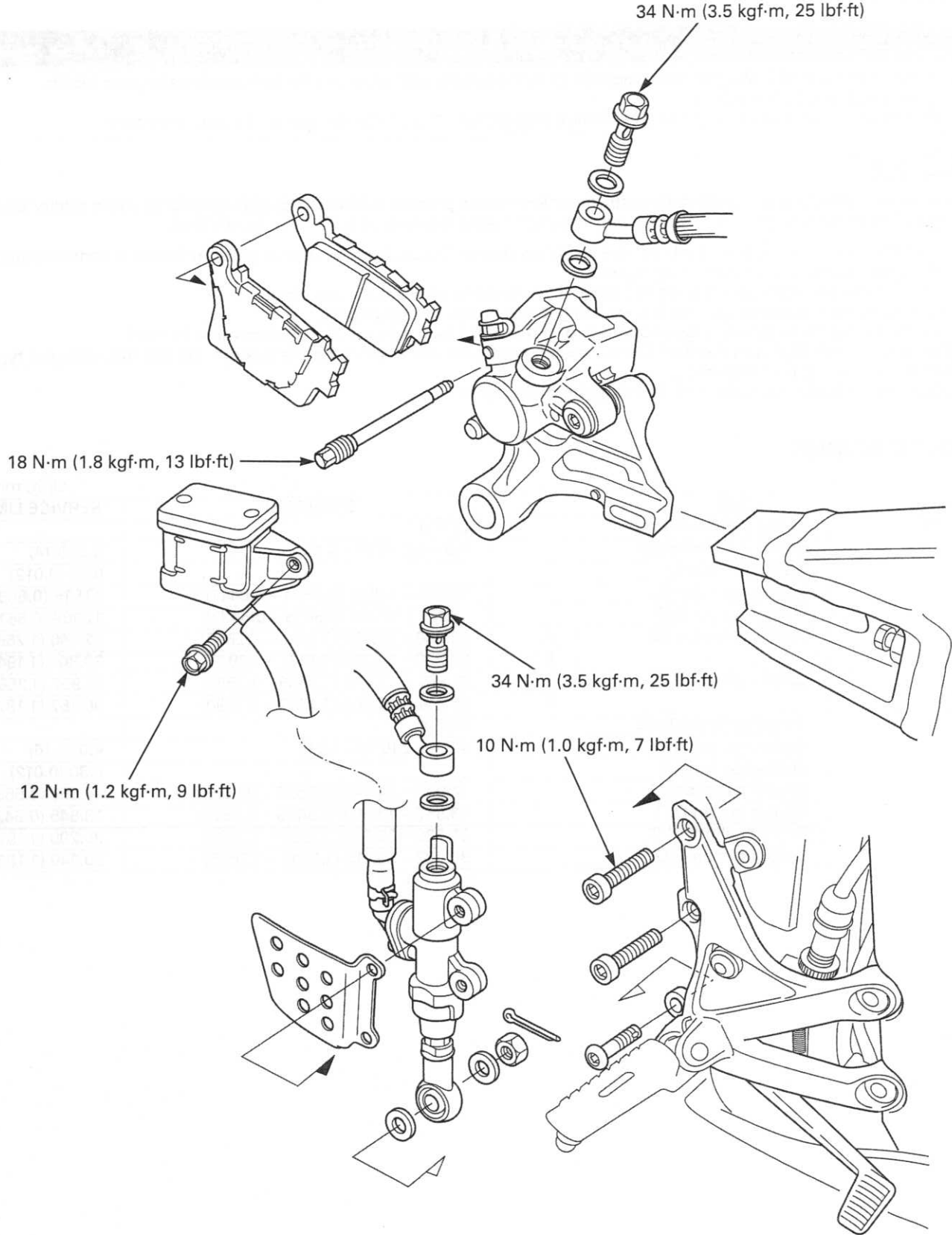

HYDRAULIC BRAKE

SERVICE INFORMATION

GENERAL

⚠ CAUTION

Frequent inhalation of brake pad dust, regardless of material composition, could be hazardous to your health.

- Avoid breathing dust particles.
- Never use an air hose or brush to clean brake assemblies. Use an OSHA-approved vacuum cleaner.

NOTICE

Spilled brake fluid will severely damage instrument lenses and painted surfaces. It is also harmful to some rubber parts. Be careful whenever you remove the reserve tank cap; make sure the reserve tank is horizontal first.

- A contaminated brake disc or pad reduces stopping power. Discard contaminated pads and clean a contaminated disc with a high quality brake degreasing agent.
- Check the brake system by applying the brake lever or pedal after the air bleeding.
- Never allow contaminants (dirt, water, etc.) to get into an open reserve tank.
- Once the hydraulic system has been opened, or if the brake feels spongy, the system must be bled.
- Always use fresh DOT 4 brake fluid from a sealed container when servicing the system. Do not mix different types of fluid; they may not be compatible.
- Always check brake operation before riding the motorcycle.

SPECIFICATIONS

Unit: mm (in)

ITEM		STANDARD	SERVICE LIMIT	
Front	Specified brake fluid	DOT 4	–	
	Brake disc thickness	4.3 – 4.5 (0.17 – 0.18)	3.5 (0.14)	
	Brake disc runout	–	0.30 (0.012)	
	Master cylinder I.D.	17.460 – 17.503 (0.6874 – 0.6891)	17.515 (0.6896)	
	Master piston O.D.	17.321 – 17.367 (0.6819 – 0.6837)	17.309 (0.6815)	
	Caliper cylinder I.D.	A	32.080 – 32.130 (1.2630 – 1.2650)	32.140 (1.2654)
		B	30.280 – 30.330 (1.1921 – 1.1941)	30.340 (1.1945)
	Caliper piston O.D.	A	31.967 – 32.000 (1.2585 – 1.2598)	31.957 (1.2581)
B		30.167 – 30.200 (1.1877 – 1.1890)	30.157 (1.1873)	
Rear	Specified brake fluid	DOT 4	–	
	Brake disc thickness	4.8 – 5.2 (0.19 – 0.20)	4.0 (0.16)	
	Brake disc runout	–	0.30 (0.012)	
	Master cylinder I.D.	14.000 – 14.043 (0.5512 – 0.5529)	14.055 (0.5533)	
	Master piston O.D.	13.957 – 13.984 (0.5495 – 0.5506)	13.945 (0.5490)	
	Caliper cylinder I.D.	30.230 – 30.280 (1.1902 – 1.1921)	30.290 (1.1925)	
	Caliper piston O.D.	30.082 – 30.115 (1.1843 – 1.1856)	30.140 (1.1866)	

TORQUE VALUES

Front master cylinder reserve tank stopper plate screw	1.2 N·m (0.1 kgf·m, 0.9 lbf·ft)	
Front brake lever pivot bolt	1.0 N·m (0.1 kgf·m, 0.7 lbf·ft)	Apply silicon grease to the sliding surface
Front brake lever pivot nut	6.0 N·m (0.6 kgf·m, 4.4 lbf·ft)	
Front brake light switch screw	1.2 N·m (0.1 kgf·m, 0.9 lbf·ft)	
Front master cylinder holder bolt	12 N·m (1.2 kgf·m, 9 lbf·ft)	
Front brake caliper assembly torx bolt	22 N·m (2.2 kgf·m, 16 lbf·ft)	Apply locking agent to the threads
Front brake caliper mounting bolt	45 N·m (4.6 kgf·m, 33 lbf·ft)	ALOC bolt; replace with a new one
Rear master cylinder reserve tank cap screw	1.5 N·m (0.2 kgf·m, 1.1 lbf·ft)	
Rear master cylinder push rod lock nut	18 N·m (1.8 kgf·m, 13 lbf·ft)	
Rear master cylinder mounting bolt	10 N·m (1.0 kgf·m, 7 lbf·ft)	
Front brake reserve tank stay bolt	12 N·m (1.2 kgf·m, 9 lbf·ft)	
Rear brake caliper mounting bolt	23 N·m (2.3 kgf·m, 17 lbf·ft)	ALOC bolt; replace with a new one
Front brake caliper pad pin	15 N·m (1.5 kgf·m, 11 lbf·ft)	
Rear brake caliper pad pin	18 N·m (1.8 kgf·m, 13 lbf·ft)	
Brake hose oil bolt	34 N·m (3.5 kgf·m, 25 lbf·ft)	
Front brake hose 3-way joint bolt	10 N·m (1.0 kgf·m, 7 lbf·ft)	
Rear brake hose joint screw	1.5 N·m (0.2 kgf·m, 1.1 lbf·ft)	Apply locking agent to the threads
Front brake caliper bleed valve	8.0 N·m (0.8 kgf·m, 5.9 lbf·ft)	
Rear brake caliper bleed valve	6.0 N·m (0.6 kgf·m, 4.4 lbf·ft)	
Main step bracket mounting bolt	37 N·m (3.8 kgf·m, 27 lbf·ft)	
Rear brake reserve tank mounting bolt	12 N·m (1.2 kgf·m, 9 lbf·ft)	

TOOL

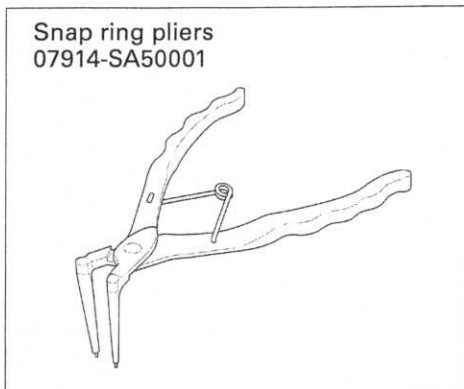

HYDRAULIC BRAKE

TROUBLESHOOTING

Brake lever/pedal soft or spongy

- Air in hydraulic system
- Leaking hydraulic system
- Contaminated brake pad/disc
- Worn caliper piston seal
- Worn master cylinder piston cups
- Worn brake pad/disc
- Contaminated caliper
- Caliper not sliding properly (rear)
- Clogged fluid passage
- Warped/deformed brake disc
- Sticking/worn caliper piston
- Sticking/worn master cylinder piston
- Contaminated master cylinder
- Bent brake lever/pedal

Brake lever/pedal hard

- Sticking/worn caliper piston
- Caliper not sliding properly (rear)
- Clogged/restricted fluid passage
- Worn caliper piston seal
- Sticking/worn master cylinder piston
- Bent brake lever/pedal
- Sticking rear brake pedal sliding surface (pillow ball)

Brake drags

- Contaminated brake pad/disc
- Misaligned wheel
- Warped/deformed brake disc
- Caliper not sliding properly (rear)
- Clogged/restricted hydraulic system
- Sticking/worn caliper piston
- Sticking master cylinder piston
- Sticking rear brake pedal sliding surface (pillow ball)

BRAKE FLUID REPLACEMENT/AIR BLEEDING

NOTICE

Spilled fluid can damage painted, plastic, or rubber parts. Place a rag over these parts whenever the system is serviced.

- Do not allow foreign material to enter the system when filling the reserve tank.

BRAKE FLUID DRAINING

Front: Turn the handlebar until the reserve tank is parallel to the ground, before removing the reserve tank cap.

Remove the screw, stopper plate and reserve tank cap.

Remove the set plate and diaphragm.

Rear: Remove the screws and reserve tank cap.
Remove the set plate and diaphragm.

Connect a bleed hose to the caliper bleed valve.

Loosen the bleed valve and pump the brake lever or pedal.

Stop pumping the lever or pedal when no more fluid flows out of the bleed valve.

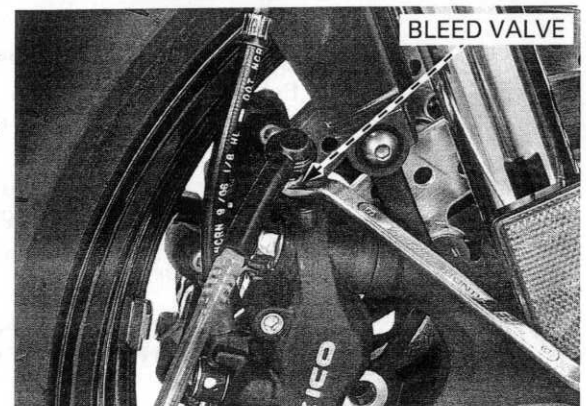
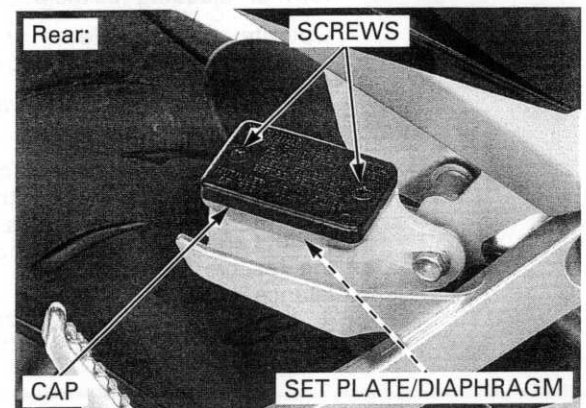
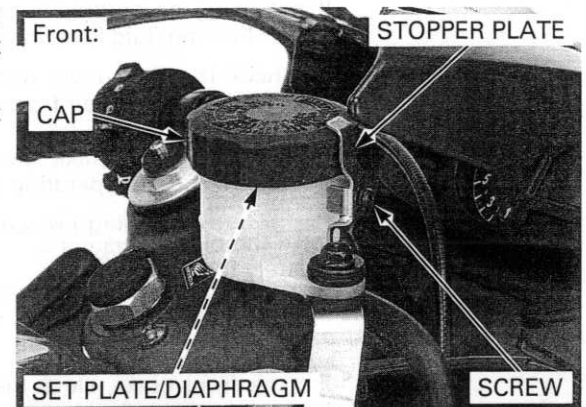

HYDRAULIC BRAKE

BRAKE FLUID FILLING/AIR BLEEDING

Fill the reserve tank with DOT 4 brake fluid from a sealed container.

NOTE:

- Use only DOT 4 brake fluid from a sealed container.
- Do not mix different types of fluid. There are not compatible.

Connect a commercially available brake bleeder to the caliper bleed valve.

Operate the brake bleeder and loosen the bleed valve.

If not using an automatic refill system, add brake fluid when the fluid level in the reserve tank is low.

- Check the fluid level often while bleeding the brakes to prevent air from being pumped into the system.
- When using a brake bleeding tool, follow the manufacturer's operating instructions.

Perform the bleeding procedure until the system is completely flushed/bled.

- If air is entering the bleeder from around the bleed valve threads, seal the threads with teflon tape.

For the front brake, close the bleed valve and perform air bleeding for the other side bleed valve.

Operate the brake lever or pedal. If it still feels spongy, bleed the system again.

If the brake bleeder is not available, perform the following procedures:

Connect a clear bleed hose to the bleed valve. Pressurize the system with the brake lever or pedal until there are no air bubbles in the fluid flowing out of the reserve tank small hole and lever or pedal resistance is felt.

1. Squeeze the brake lever or push the brake pedal, open the bleed valve 1/2 turn and then close the valve.

NOTE:

- Do not release the brake lever or pedal until the bleed valve has been closed.
2. Release the brake lever or pedal slowly and wait several seconds after it reaches the end of its travel.
 3. Repeat steps 1 and 2 until bubbles cease to appear in the fluid coming out of the bleed valve.
 4. Tighten the bleed valve to the specified torque.

TORQUE:

Front: 8.0 N·m (0.8 kgf·m, 5.9 lbf·ft)

Rear: 6.0 N·m (0.6 kgf·m, 4.4 lbf·ft)

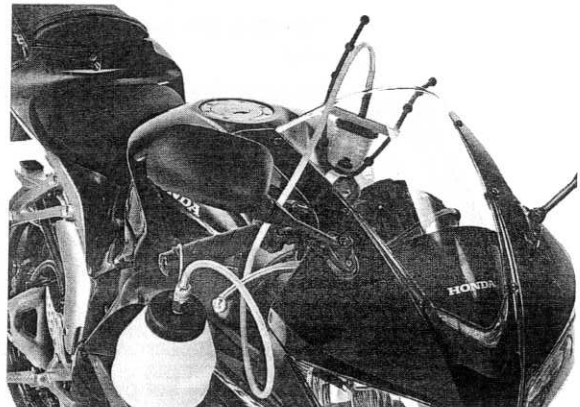
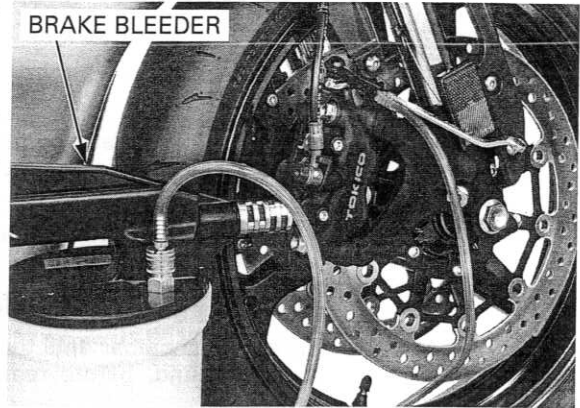

Front: Perform air bleeding for the other side bleed valve.
 Fill each reserve tank to the upper level with DOT 4 brake fluid from a sealed container.
 Reinstall the diaphragm and set plate.

On the front brake, install the reserve tank cap, stopper plate and tighten the screw to the specified torque.

TORQUE: 1.2 N·m (0.1 kgf·m, 0.9 lbf·ft)

Front:

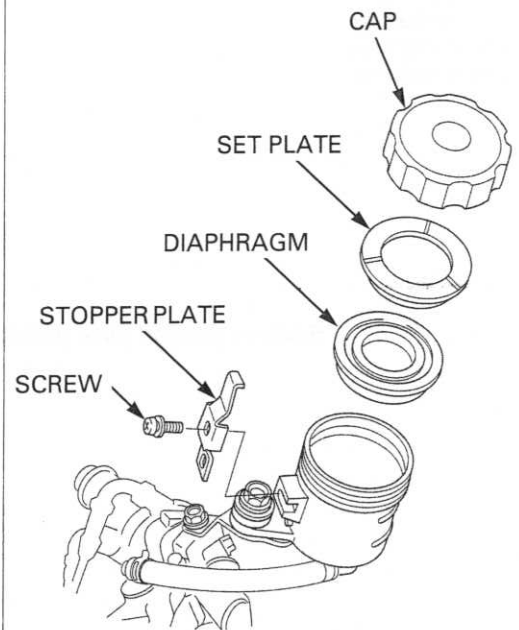

Rear: Install the reserve tank cap and tighten the screws to the specified torque.

TORQUE: 1.5 N·m (0.2 kgf·m, 1.1 lbf·ft)

Rear:

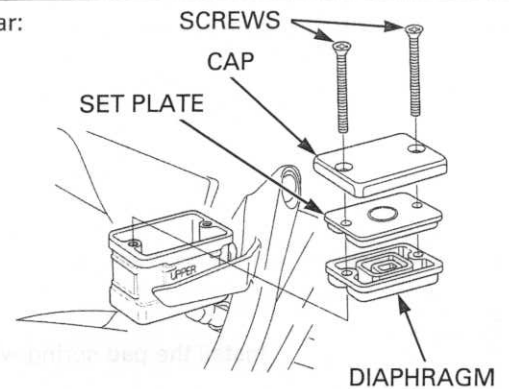

BRAKE PAD/DISC

FRONT BRAKE PAD REPLACEMENT

Loosen the pad pins.
 Remove the caliper mounting bolts and brake caliper.

Discard the brake caliper mounting bolts.

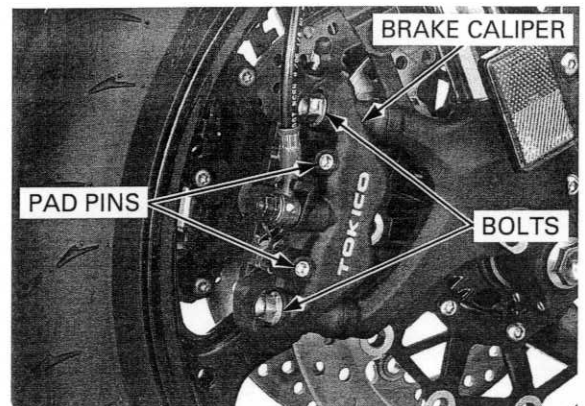

HYDRAULIC BRAKE

Check the brake fluid level in the brake master cylinder reserve tank as this operation causes the level to rise.

Push the caliper pistons all the way in to allow installation of new brake pads.

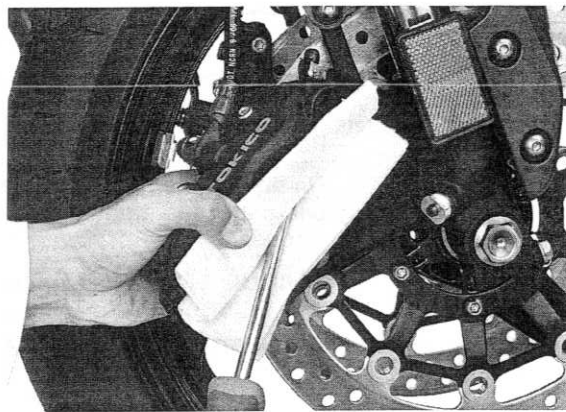

Remove the pad pins, pad spring and brake pads.

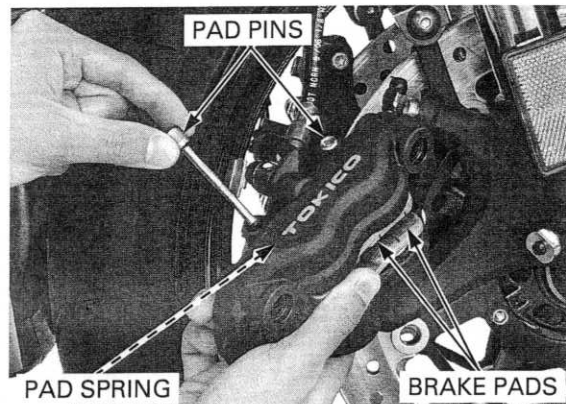

Clean the inside of the caliper especially around the caliper pistons.

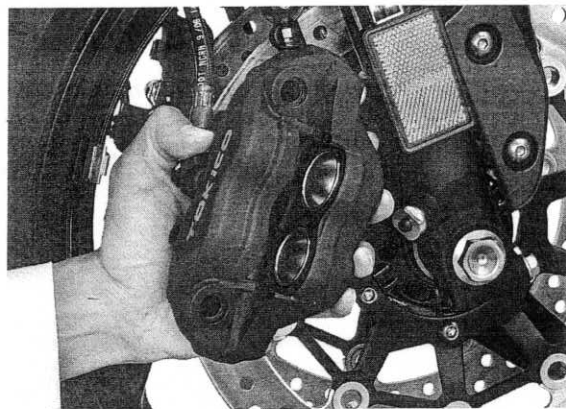

Install the pad spring with its bent side downward.

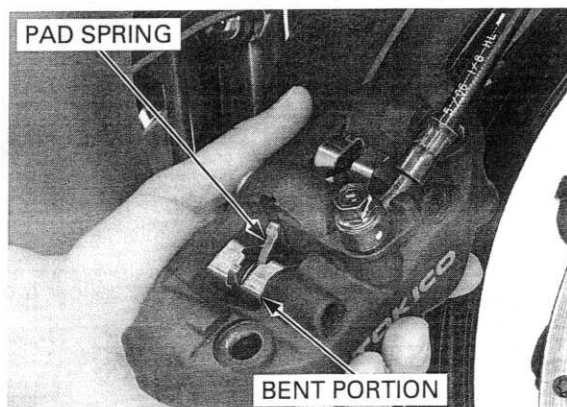

Always replace the brake pads in pairs to assure even disc pressure.

Install new brake pads to the brake caliper.

Install the pad pins while pushing in the brake pads against the pad spring.

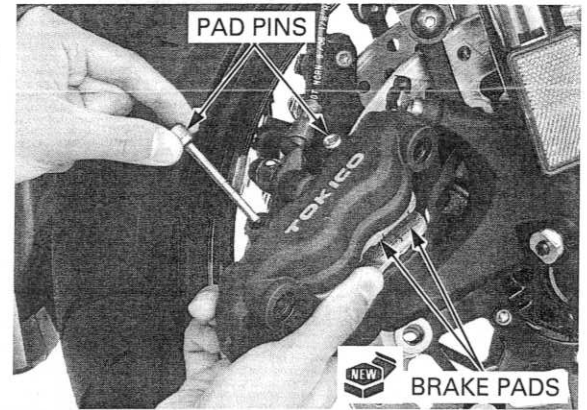

Install the brake caliper to the fork leg so that the disc is positioned between the pads.

NOTE:

- Make sure that the dowel pins are installed into the caliper bracket properly.
- Be careful not to damage the brake pads.

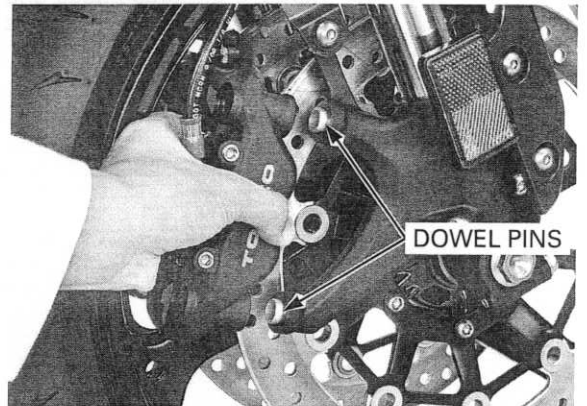

Tighten new brake caliper mounting bolts to the specified torque.

TORQUE: 45 N·m (4.6 kgf·m, 33 lbf·ft)

Tighten the pad pins to the specified torque.

TORQUE: 15 N·m (1.5 kgf·m, 11 lbf·ft)

Check the brake operation by applying the brake lever.

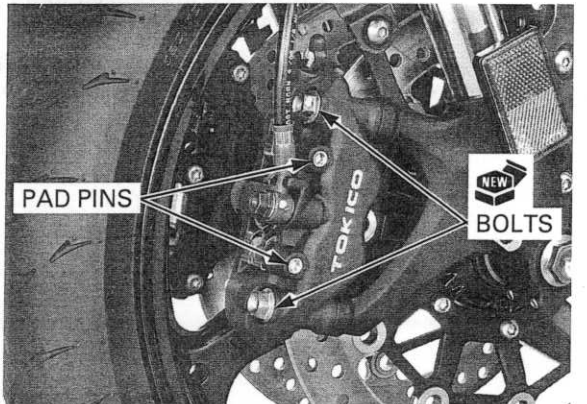

REAR BRAKE PAD REPLACEMENT

Check the brake fluid level in the brake master cylinder reserve tank as this operation causes the level to rise.

Push the caliper piston all the way in by pushing the caliper body inward to allow installation of new brake pads.

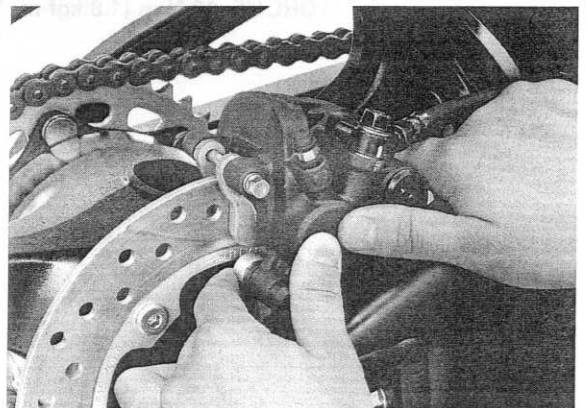

HYDRAULIC BRAKE

Remove the pad pin.

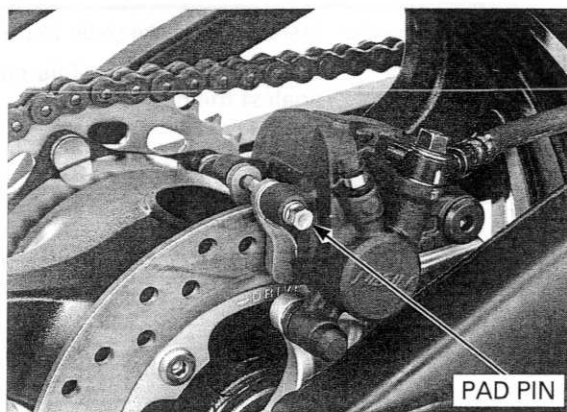

Remove the brake pads and clean the inside of the caliper especially around the caliper piston.

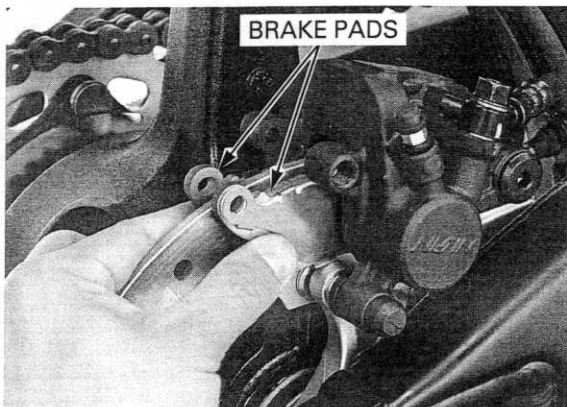

Apply silicone grease to a new O-ring and install it to the pad pin groove.

Always replace the brake pads in pairs to assure even disc pressure.

Make sure the pad spring is in place and install new brake pads securely.

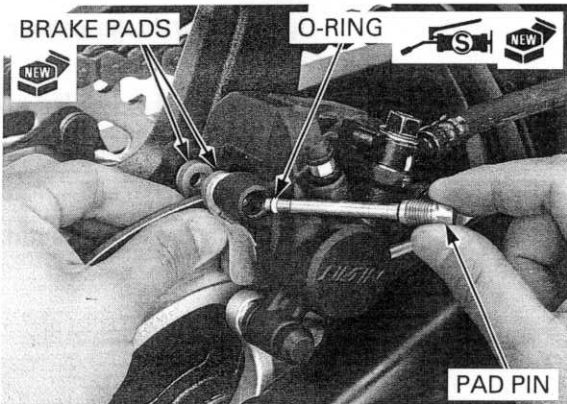

Tighten the pad pin to the specified torque.

TORQUE: 18 N·m (1.8 kgf·m, 13 lbf·ft)

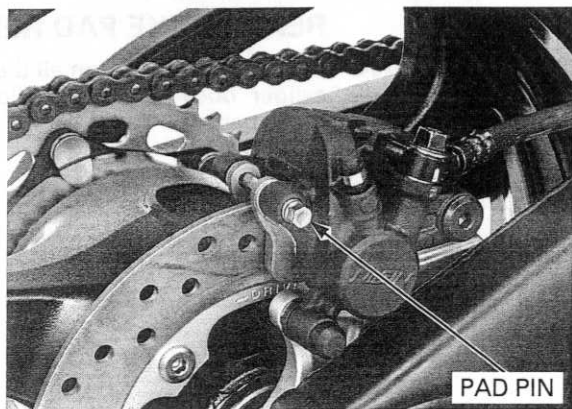

BRAKE DISC INSPECTION

Visually inspect the brake discs for damage or cracks.

Measure the brake disc thickness with a micrometer.

SERVICE LIMITS:

FRONT: 3.5 mm (0.14 in)

REAR: 4.0 mm (0.16 in)

Replace the brake disc if the smallest measurement is less than the service limit.

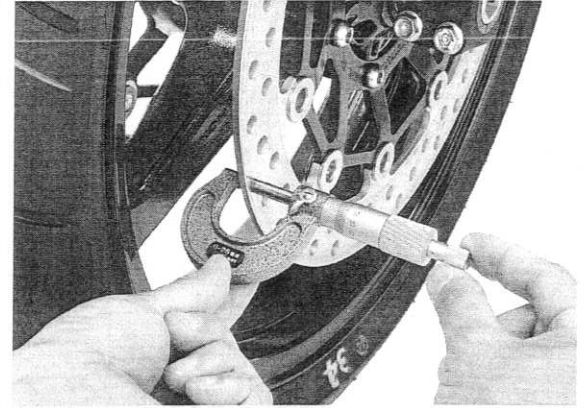

Measure the brake disc runout with a dial indicator.

SERVICE LIMITS:

FRONT: 0.30 mm (0.012 in)

REAR: 0.30 mm (0.012 in)

Check the wheel bearings for excessive play (page 14-17), if the warpage exceeds the service limit. Replace the brake disc if the wheel bearings are normal.

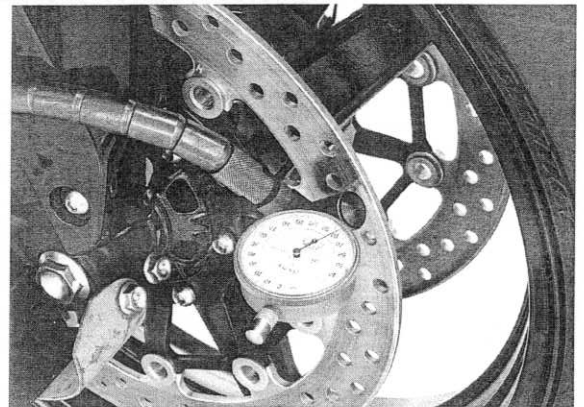

FRONT MASTER CYLINDER

NOTICE

Spilled fluid can damage painted, plastic, or rubber parts. Place a rag over these parts whenever the system is serviced.

REMOVAL

Drain the front hydraulic system (page 16-7).

Disconnect the brake light switch wire connectors.

Remove the brake hose oil bolt, sealing washers and brake hose eyelet joint.

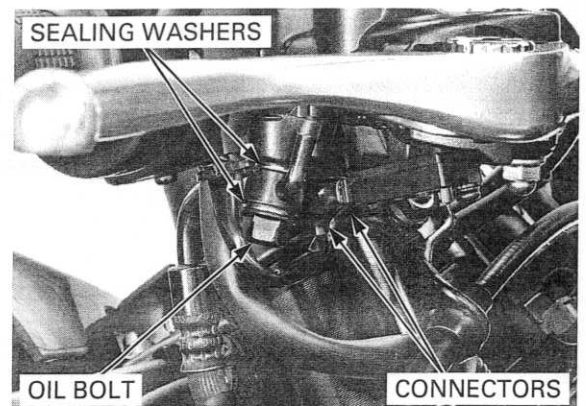

HYDRAULIC BRAKE

Remove the bolts from the master cylinder holder and remove the master cylinder assembly.

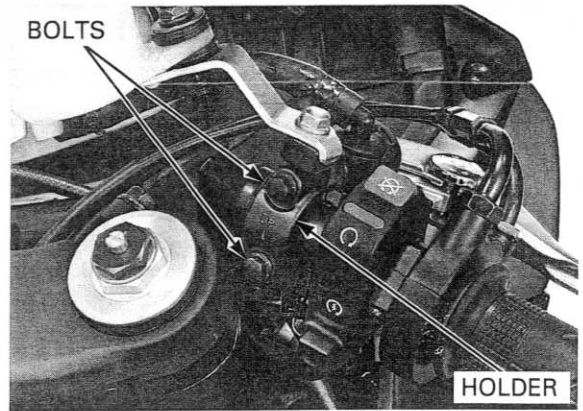

DISASSEMBLY

Remove the dust cover and snap ring.

TOOL:

Snap ring pliers

07914-SA50001

Remove the bolt and reserve tank from the master cylinder.

Remove the O-ring from the reserve tank hose joint.

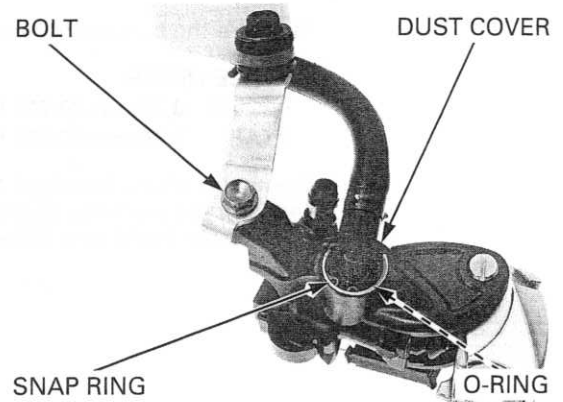

Remove the pivot bolt, nut and brake lever assembly.

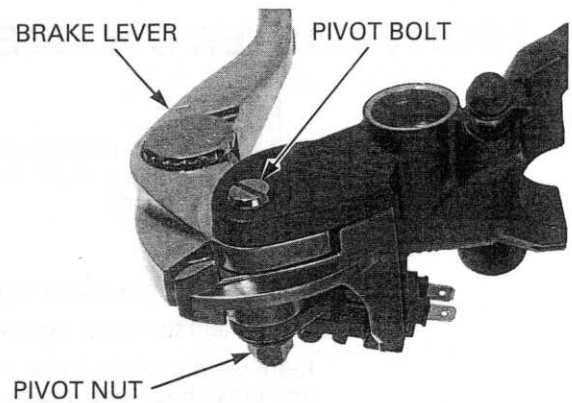

Remove the screw and brake light switch.

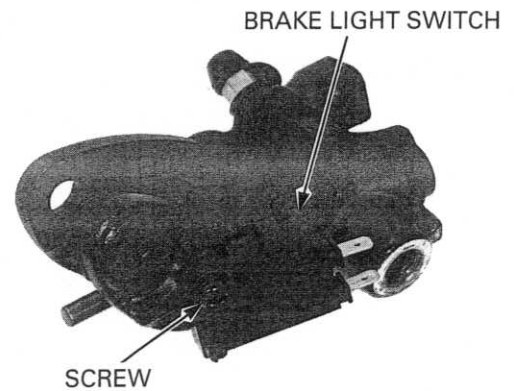

Be careful not to damage the boot. Remove the boot and push rod.

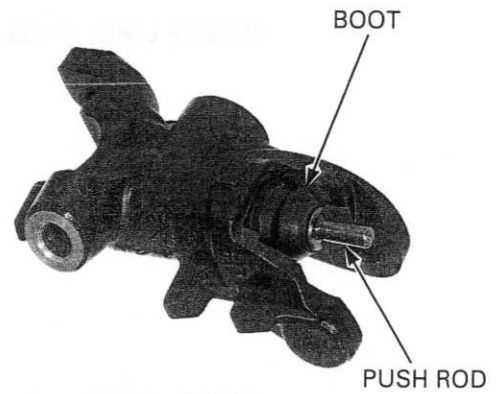

Remove the snap ring from the master cylinder body using the special tool as shown.

TOOL:
Snap ring pliers 07914-SA50001

Remove the master piston, spring and spring guide from the master cylinder body.

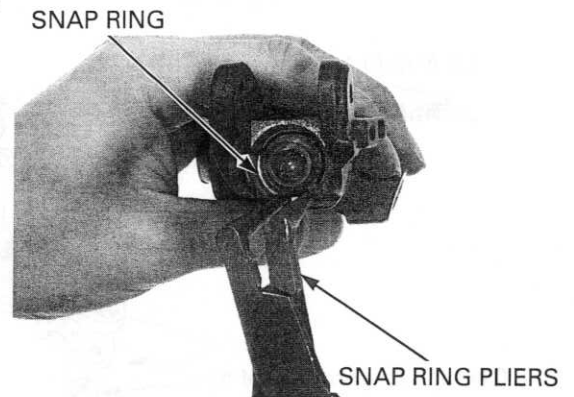

INSPECTION

Clean the inside of the cylinder and reserve tank with clean brake fluid.
Check the master cylinder and piston for abnormal scratches.
Check the spring for fatigue or damage.

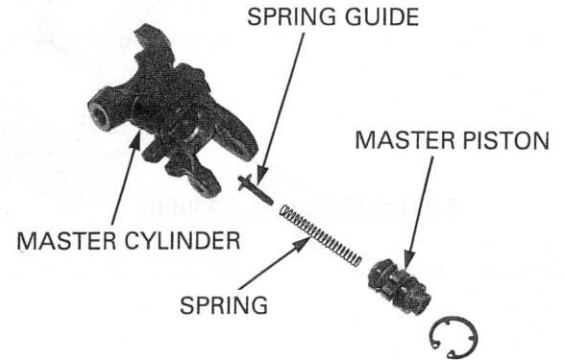

Measure the master cylinder I.D.

SERVICE LIMIT: 17.515 mm (0.6896 in)



HYDRAULIC BRAKE

Measure the master cylinder piston O.D.

SERVICE LIMIT: 17.309 mm (0.6815 in)



ASSEMBLY

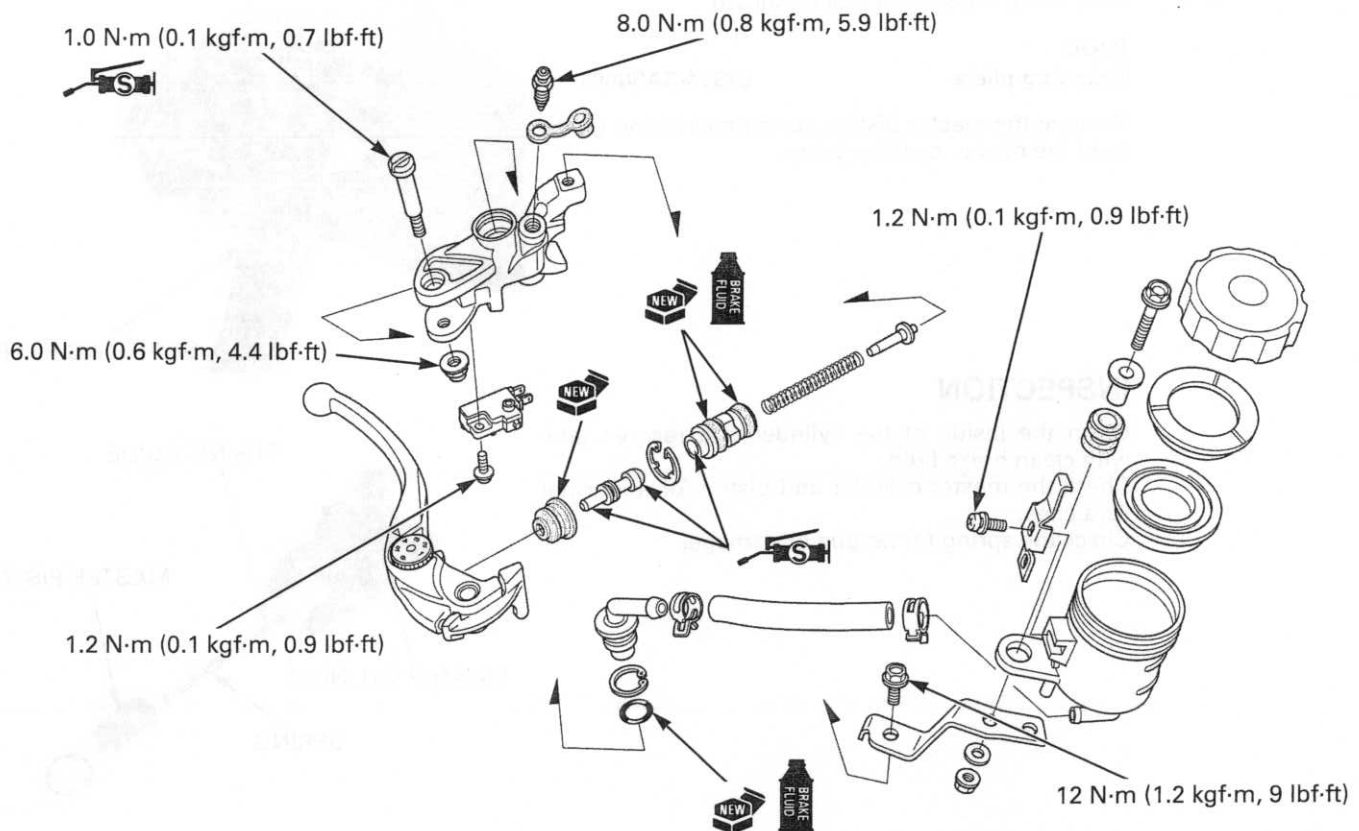

- Keep the piston, cups, spring, snap ring and boot as a set; do not substitute individual parts.

Coat new piston caps with clean brake fluid and install them to the master piston.

Coat the master piston and piston cups with clean brake fluid.

Install the spring guide into the spring.

Install the spring guide/spring and master piston into the master cylinder.

When installing the cups, do not allow the lips to turn inside out.

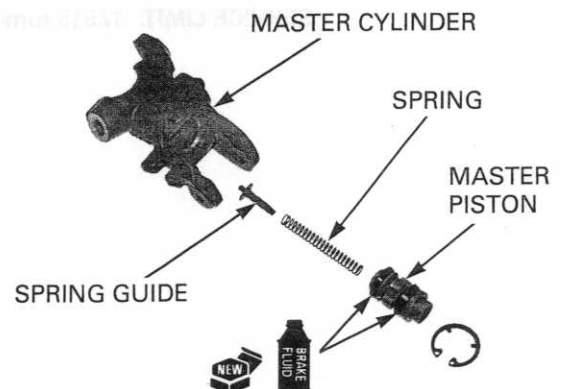

Be certain the snap ring is firmly seated in the groove.

Install the snap ring with the special tool.

TOOL:
Snap ring pliers

07914-SA50001

SNAP RING

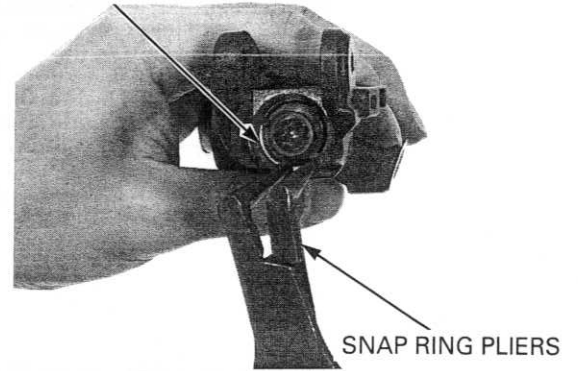

Apply silicone grease to contact surfaces of the push rod and master piston.
Install a new boot with the push rod.

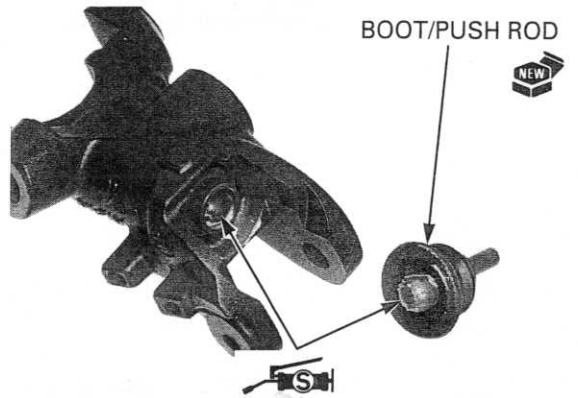

Install the brake light switch by aligning its boss with the hole.

Tighten the screw to the specified torque.

TORQUE: 1.2 N·m (0.1 kgf·m, 0.9 lbf·ft)

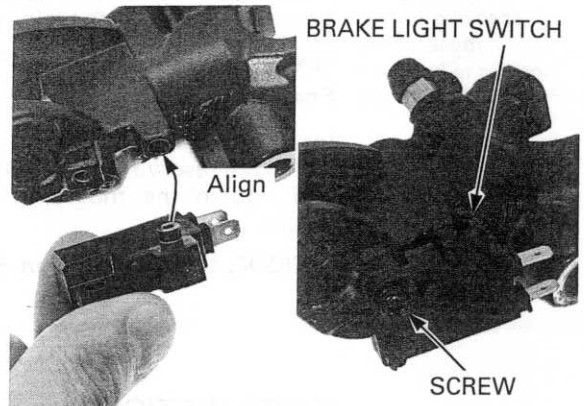

Apply silicone grease to push rod tip.
Install the brake lever by aligning the hole of the brake lever with the push rod.

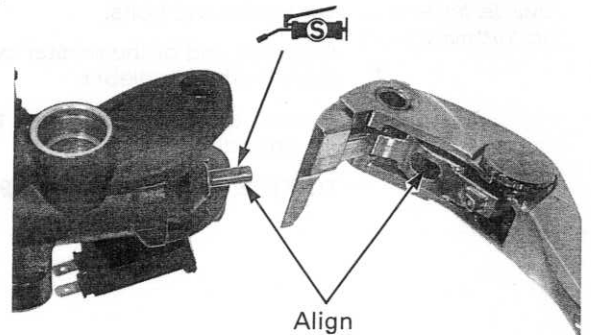

HYDRAULIC BRAKE

Apply silicone grease to the brake lever pivot bolt sliding surface.

Install the brake lever pivot bolt and nut.
Tighten the pivot bolt to the specified torque.

TORQUE: 1.0 N·m (0.1 kgf·m, 0.7 lbf·ft)

Hold the pivot bolt and tighten the pivot nut to the specified torque.

TORQUE: 6.0 N·m (0.6 kgf·m, 4.4 lbf·ft)

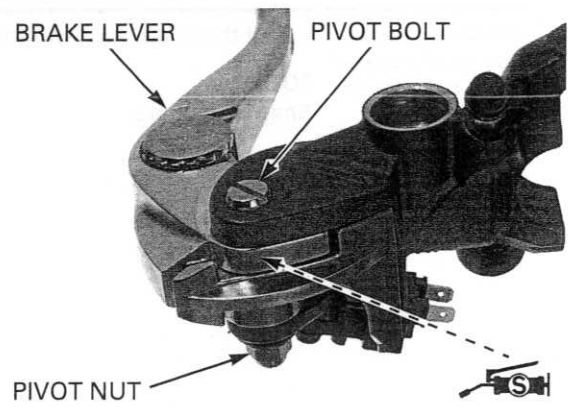

Apply brake fluid to a new O-ring and install it to the reserve tank hose joint.

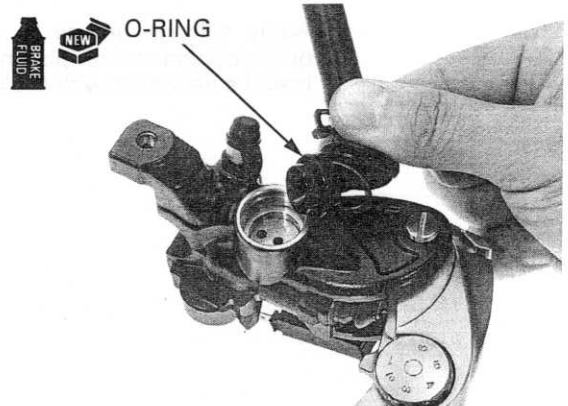

After installing a snap ring, always rotate it in its groove to be sure it is fully seated.

Install the reserve tank hose joint into the master cylinder and secure the joint with the snap ring.

TOOL:
Snap ring pliers

07914-SA50001

Install the dust cover.
Install the reserve tank stay onto the master cylinder and tighten the mounting bolt to the specified torque.

TORQUE: 12 N·m (1.2 kgf·m, 9 lbf·ft)

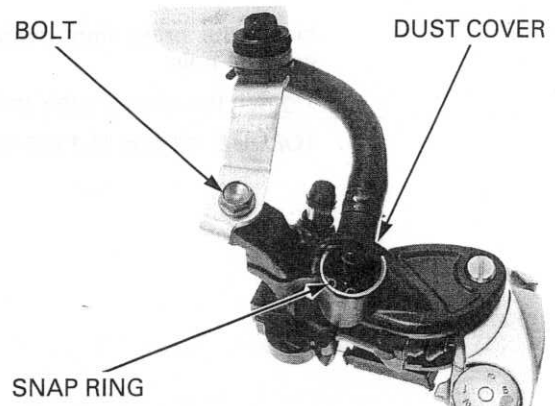

INSTALLATION

Install the master cylinder holder with its "UP" mark facing up.

Install the master cylinder assembly, master cylinder holder and bolts.

Align the end of the master cylinder with the punch mark on the handlebar.

Tighten the upper bolt first, then the lower bolt to the specified torque.

TORQUE: 12 N·m (1.2 kgf·m, 9 lbf·ft)

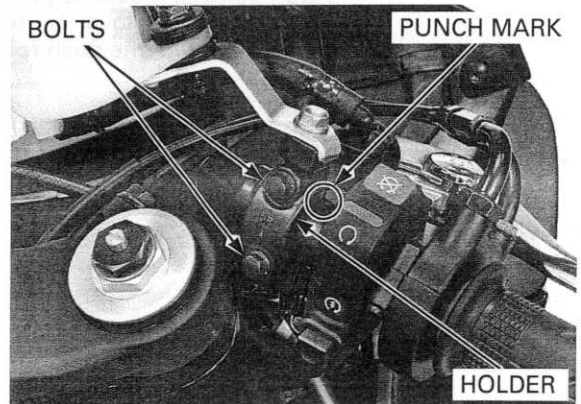

Install the brake hose eyelet joint with new sealing washers and oil bolt.

Push the eyelet joint against the stopper then tighten the oil bolt to the specified torque.

TORQUE: 34 N·m (3.5 kgf·m, 25 lbf·ft)

Connect the brake light switch connectors.

Fill brake fluid and bleed air the rear brake hydraulic system (page 16-8).

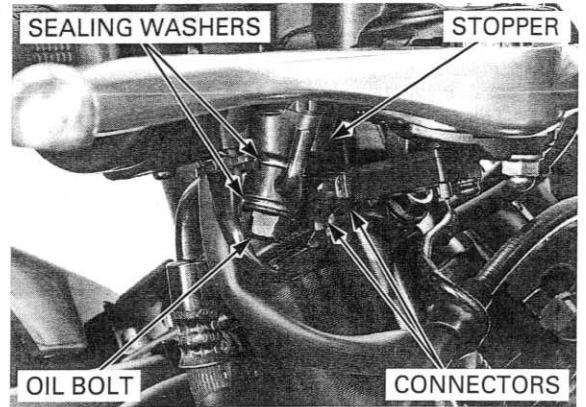

REAR MASTER CYLINDER

NOTICE

Spilled fluid can damage painted, plastic, or rubber parts. Place a rag over these parts whenever the system is serviced.

REMOVAL

Drain the rear hydraulic system (page 16-7).

Remove the bolts and right passenger step bracket.

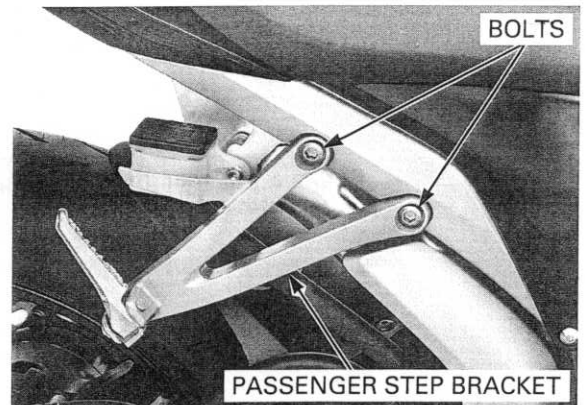

Remove the bolt and rear master cylinder reserve tank.

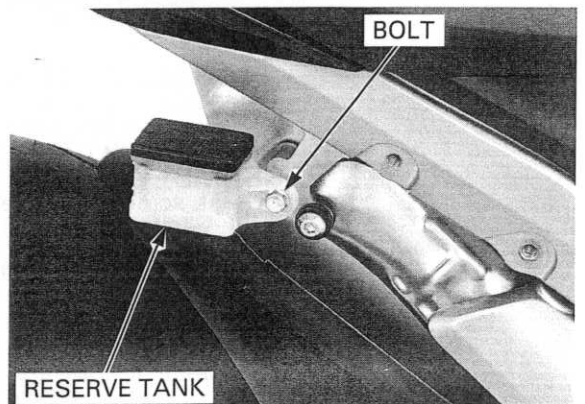

HYDRAULIC BRAKE

Avoid spilling fluid on painted, plastic, or rubber parts. Place a rag over these parts whenever the system is serviced.

Remove the brake hose oil bolt, sealing washers and brake hose eyelet joint.

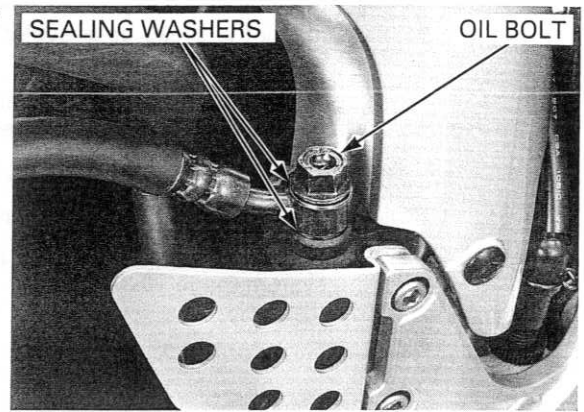

Remove the cotter pin, nut, washers and bolt.

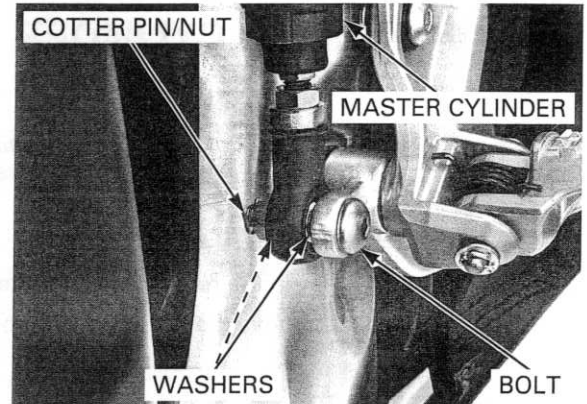

Remove the rear master cylinder mounting bolts and master cylinder guard plate.

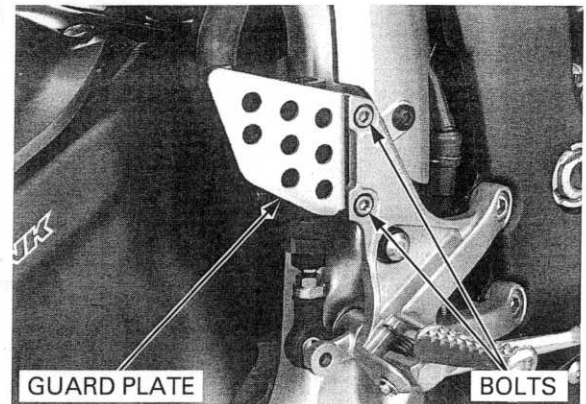

DISASSEMBLY

Remove the screw and hose joint from the master cylinder.

Remove the O-ring from the hose joint.

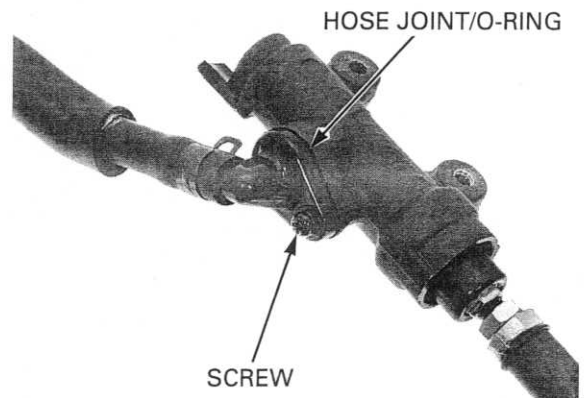

Be careful not to damage the boot.

Remove the boot from the master cylinder body.
Remove the snap ring from the master cylinder body using the special tool as shown.

TOOL:

Snap ring pliers

07914-SA50001

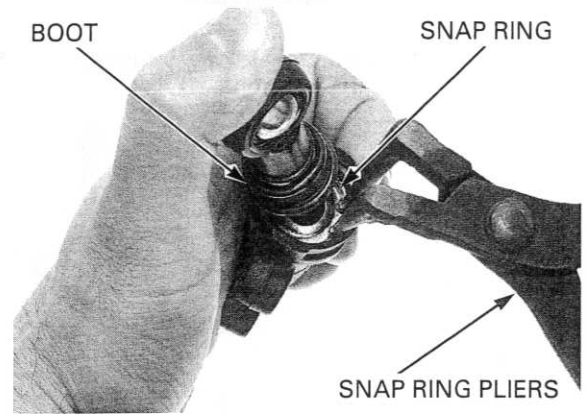

Remove the push rod assembly, master piston and spring.

Clean the inside of the cylinder with clean brake fluid.

Check the pillow ball movement.

Replace the tie rod if the pillow ball does not move smoothly.

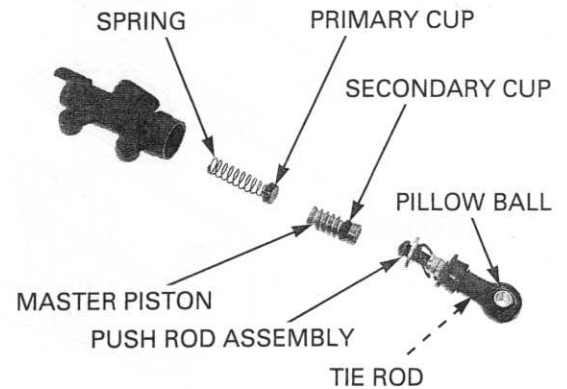

INSPECTION

Check the piston boot, primary cup and secondary cup for fatigue or damage.

Check the master cylinder and piston for abnormal scratches.

Measure the master I.D.

SERVICE LIMIT: 14.055 mm (0.5533 in)

Measure the master cylinder piston O.D.

SERVICE LIMIT: 13.945 mm (0.5490 in)

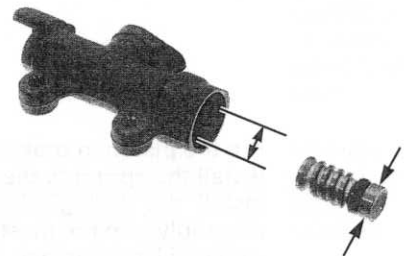

HYDRAULIC BRAKE

ASSEMBLY

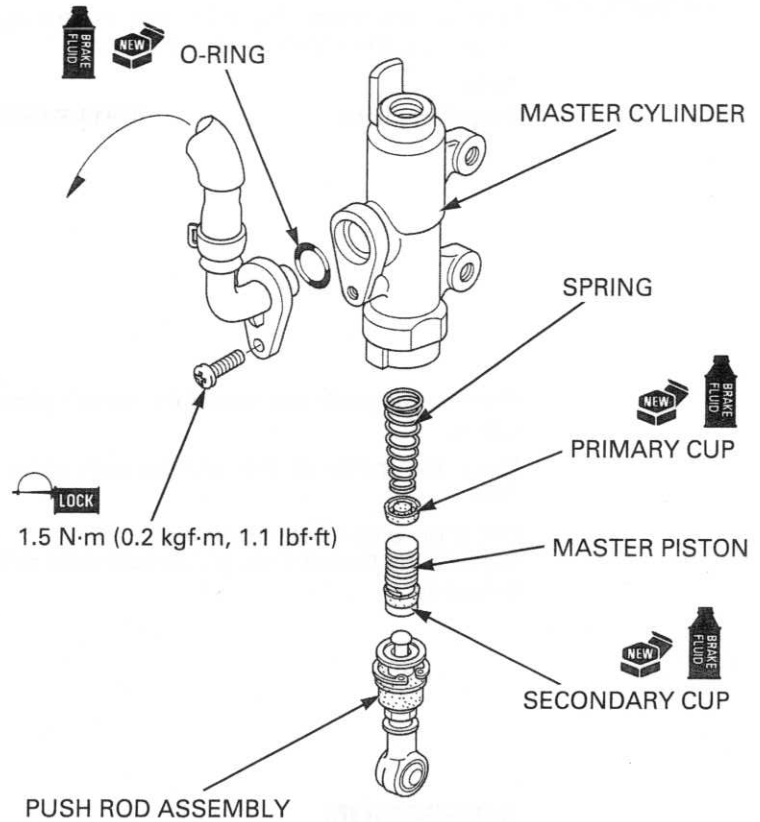
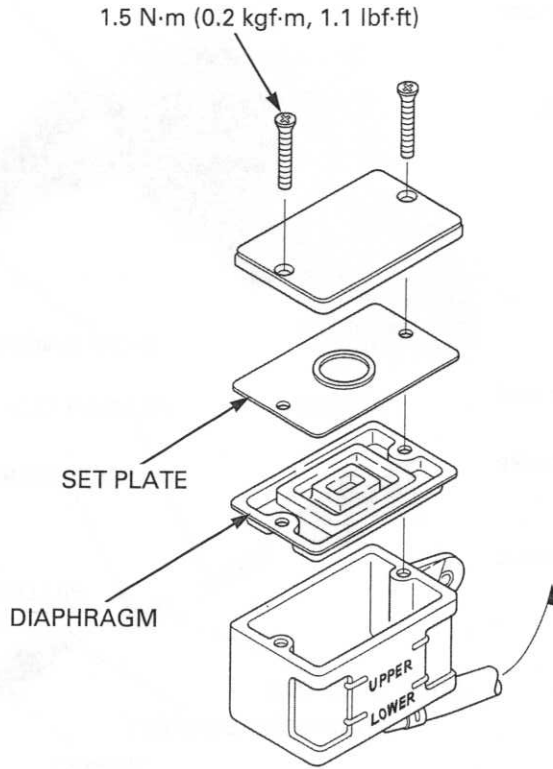

Keep the piston, cups, spring, snap ring and boot as a set; do not substitute individual parts.

Coat all parts with clean brake fluid before assembly.

When installing the cups, do not allow the lips to turn inside out.

Dip the piston in brake fluid. Install the spring to the primary cup. Install the spring/primary cup and master piston assembly into the master cylinder. Apply silicone grease to the piston contact area of the push rod.

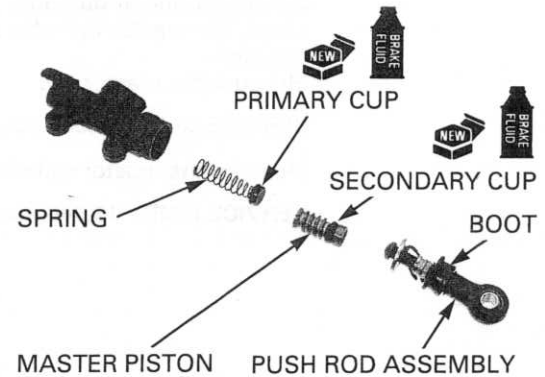

Install the push rod assembly into the master cylinder.

Be certain the snap ring is firmly seated in the groove.

Install the snap ring with the special tool.

TOOL:
Snap ring pliers

07914-SA50001

Install the boot.

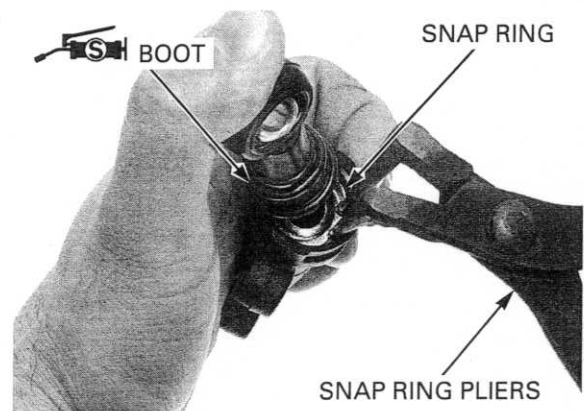

Apply brake fluid to a new O-ring and install it onto the hose joint.
Install the hose joint into the master cylinder.

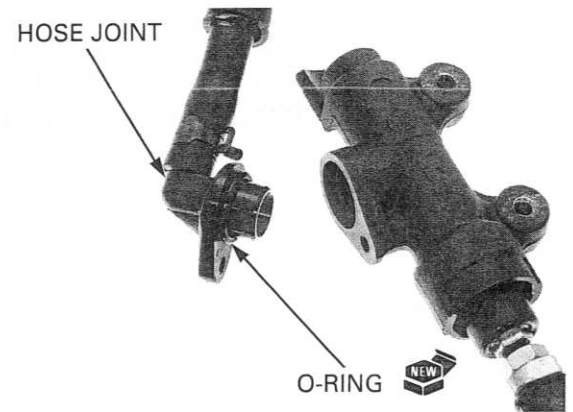

Apply locking agent to the hose joint screw threads.
Tighten the screw to the specified torque.

TORQUE: 1.5 N·m (0.2 kgf·m, 1.1 lbf·ft)

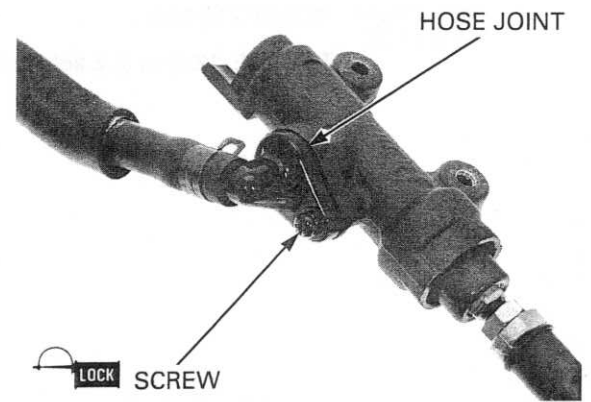

INSTALLATION

Install the master cylinder and guard plate, tighten the bolts to the specified torque.

TORQUE: 10 N·m (1.0 kgf·m, 7 lbf·ft)

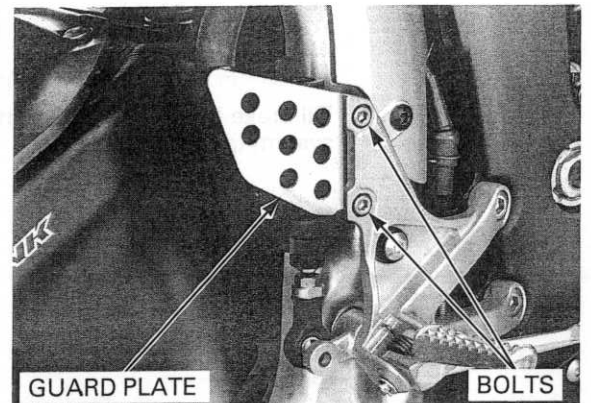

Connect the brake pedal to the push rod lower joint.
Install the bolt, washers, nut and tighten the nut securely.

Install a new cotter pin.

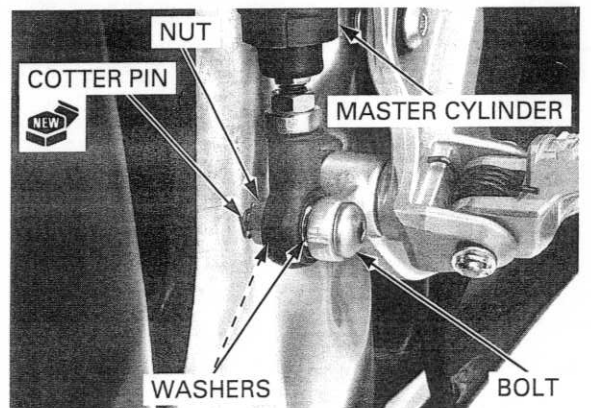

HYDRAULIC BRAKE

Install the brake hose with the oil bolt and new sealing washers.

Push the eyelet joint against the stopper, then tighten the oil bolt to the specified torque.

TORQUE: 34 N·m (3.5 kgf·m, 25 lbf·ft)

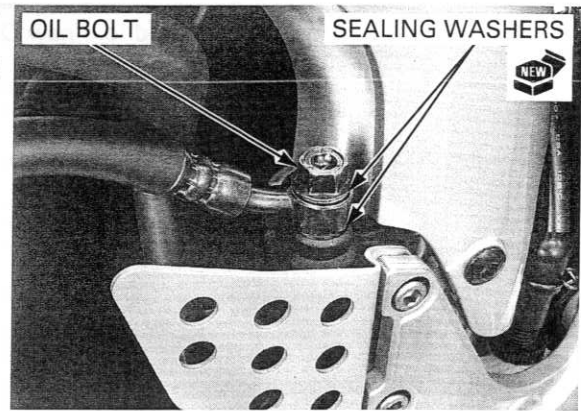

Route the brake hose properly (page 1-21).

Install the reserve tank and tighten the bolt to the specified torque.

TORQUE: 12 N·m (1.2 kgf·m, 9 lbf·ft)

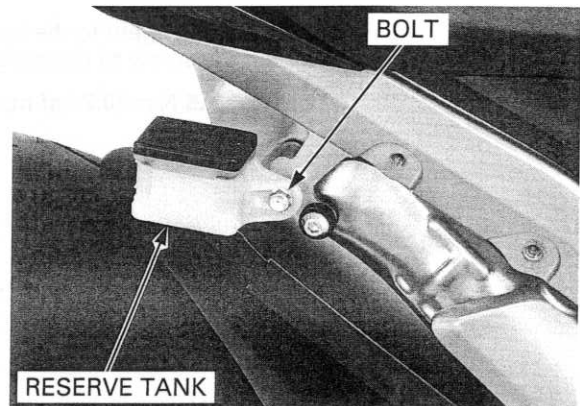

Install the right passenger step bracket and tighten the bolts to the specified torque.

TORQUE: 26 N·m (2.7 kgf·m, 19 lbf·ft)

Adjust the rear brake pedal height (page 4-30).

Fill brake fluid and bleed air the rear brake hydraulic system (page 16-8).

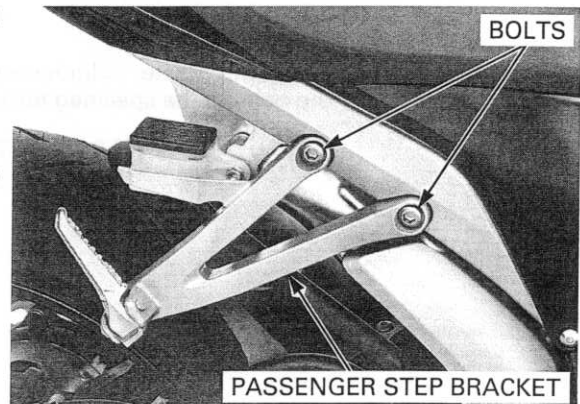

FRONT BRAKE CALIPERS

NOTICE

Spilled fluid can damage painted, plastic, or rubber parts. Place a rag over these parts whenever the system is serviced.

REMOVAL

Drain the front brake hydraulic system (page 16-7).

Remove the brake hose oil bolt, sealing washers and brake hose eyelet joint.

Remove the brake pads (page 16-9).

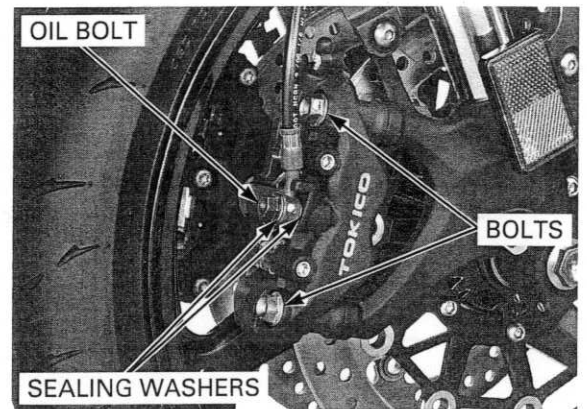

DISASSEMBLY

Place a shop towel over the piston.

Do not use high pressure air or bring the nozzle too close to the inlet.

Apply small squirts of air pressure to the fluid inlet to remove the pistons.



Remove the torx bolts and separate the caliper halves.

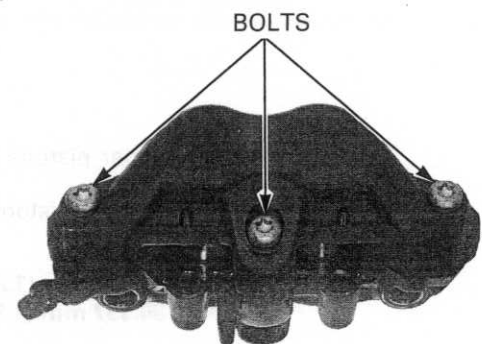

HYDRAULIC BRAKE

Mark the pistons to ensure correct reassembly.

Remove the following:

- Joint seal
- Caliper piston A
- Caliper piston B

Be careful not to damage the piston sliding surface.

Push the dust seals and piston seals in and lift them out. Clean the seal grooves with clean brake fluid.

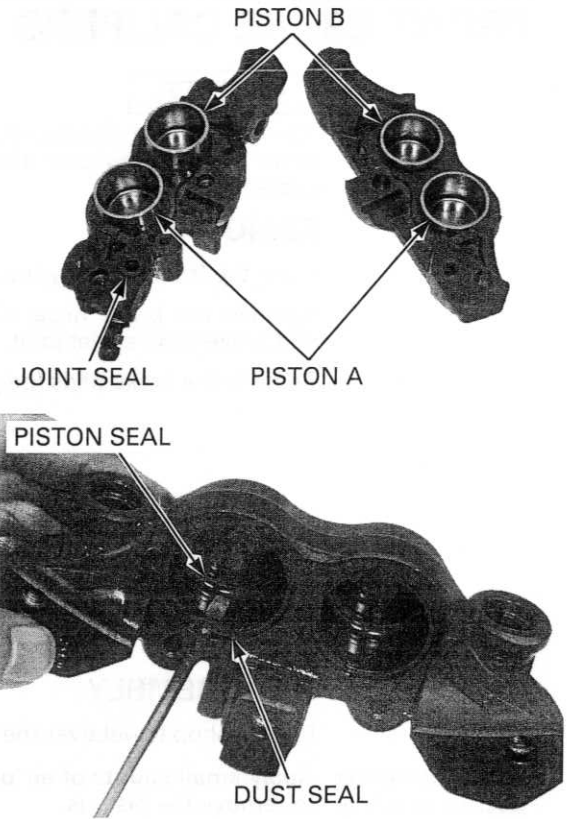

INSPECTION

Check the caliper cylinder for scoring or other damage. Measure the caliper cylinder I.D.

SERVICE LIMITS:

- Cylinder A: 32.140 mm (1.2654 in)
- Cylinder B: 30.340 mm (1.1945 in)

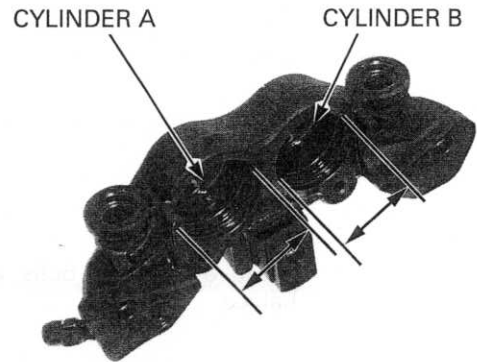

Check the caliper pistons for scratches, scoring or other damage. Measure the caliper piston O.D.

SERVICE LIMITS:

- Piston A: 31.957 mm (1.2581 in)
- Piston B: 30.157 mm (1.1873 in)

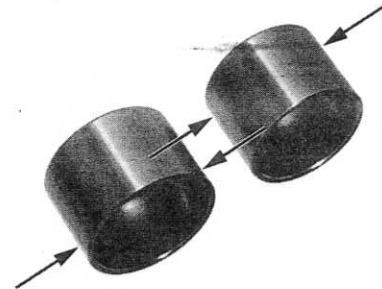

ASSEMBLY

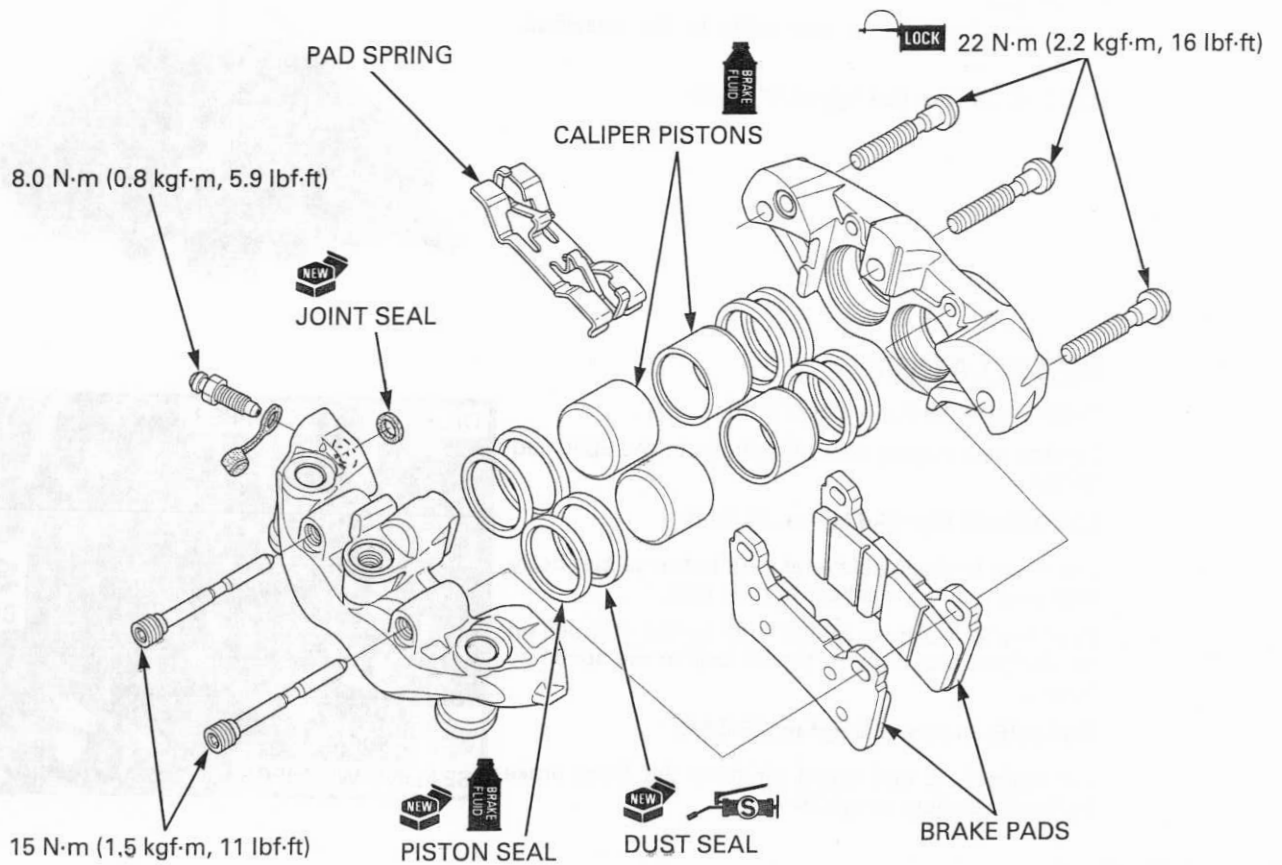

Coat new piston seals with clean brake fluid.
Coat new dust seals with silicone grease.

Install each piston seal, dust seal and caliper piston in their proper locations.

Install the piston and dust seals into the grooves of the caliper body.
Coat the caliper pistons with clean brake fluid and install them into the caliper cylinder with their open ends toward the pad.

Install a new joint seal into the fluid passage on the caliper.

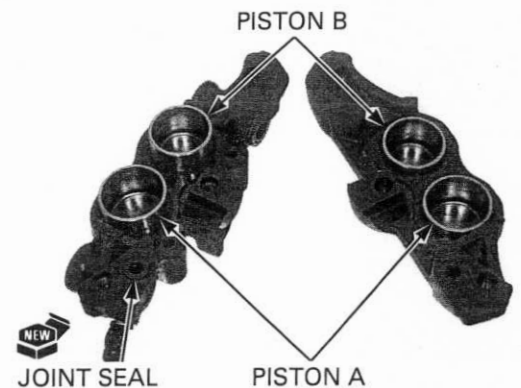
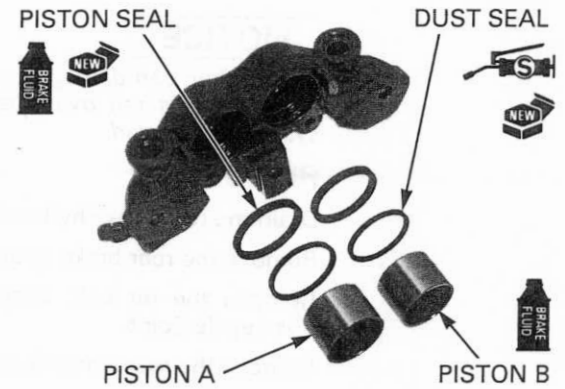

HYDRAULIC BRAKE

Assemble the caliper halves.
Apply locking agent to the caliper assembly torx bolt threads.
Install and tighten the torx bolts to the specified torque.

TORQUE: 23 N·m (2.3 kgf·m, 17 lbf·ft)

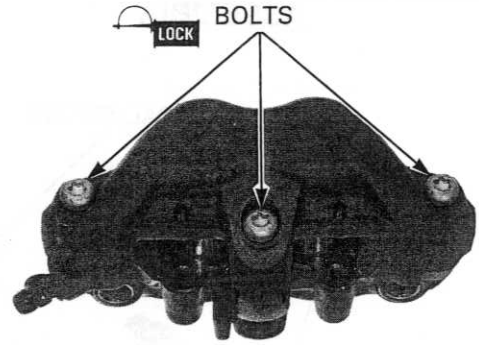

INSTALLATION

Install the brake pads (page 16-9).

Tighten new caliper mounting bolts to the specified torque.

TORQUE: 45 N·m (4.6 kgf·m, 33 lbf·ft)

Install the brake hose eyelet joint to the caliper body with new sealing washers and oil bolt.

Push the brake hose eyelet joint to the stopper on the caliper, then tighten the oil bolt to the specified torque.

TORQUE: 34 N·m (3.5 kgf·m, 25 lbf·ft)

Fill brake fluid and bleed air from the front brake hydraulic system (page 16-7).

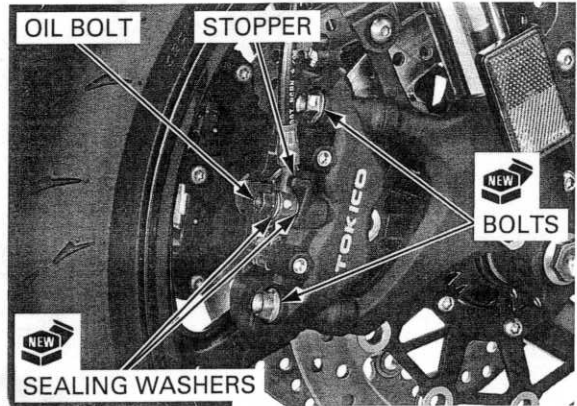

REAR BRAKE CALIPER

NOTICE

Spilled fluid can damage painted, plastic, or rubber parts. Place a rag over these parts whenever the system is serviced.

REMOVAL

Drain the rear brake hydraulic system (page 16-7).

Remove the rear brake pads (page 16-11).

Remove the oil bolt, sealing washers and brake hose eyelet joint.

Remove the rear wheel (page 15-7).



DISASSEMBLY

Remove the caliper bracket and pad spring from the caliper body.

Remove the retainer from the caliper bracket.

Remove the caliper pin boot and bracket pin boot.

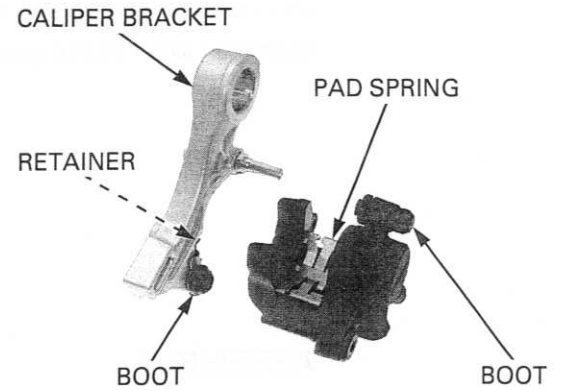

Place a shop towel over the piston.

Do not use high pressure air or bring the nozzle too close to the inlet.

Position the caliper body with the piston down and apply small squirts of air pressure to the fluid inlet to remove the piston.

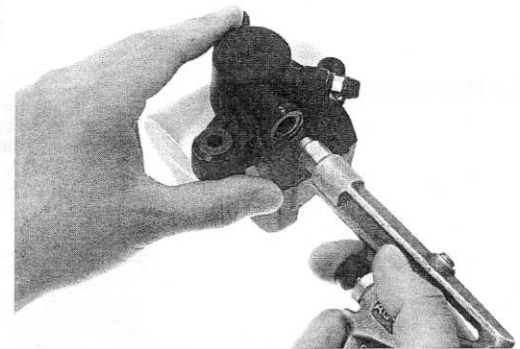

Be careful not to damage the piston sliding surface.

Push the dust seal and piston seal in and lift them out.

Clean the seal grooves with clean brake fluid.

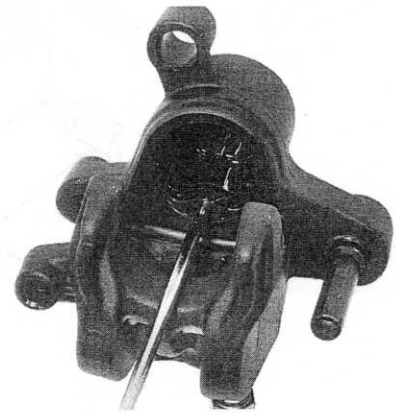

INSPECTION

Check the caliper cylinder for scoring or other damage.

Measure the caliper cylinder I.D.

SERVICE LIMIT: 30.290 mm (1.1925 in)

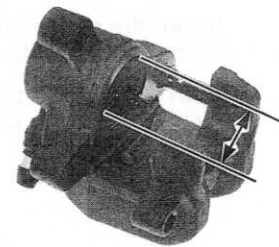

HYDRAULIC BRAKE

Check the caliper piston for scratches, scoring or other damage.

Measure the caliper piston O.D.

SERVICE LIMIT: 30.140 mm (1.1866 in)

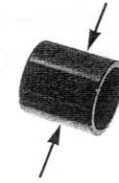

ASSEMBLY

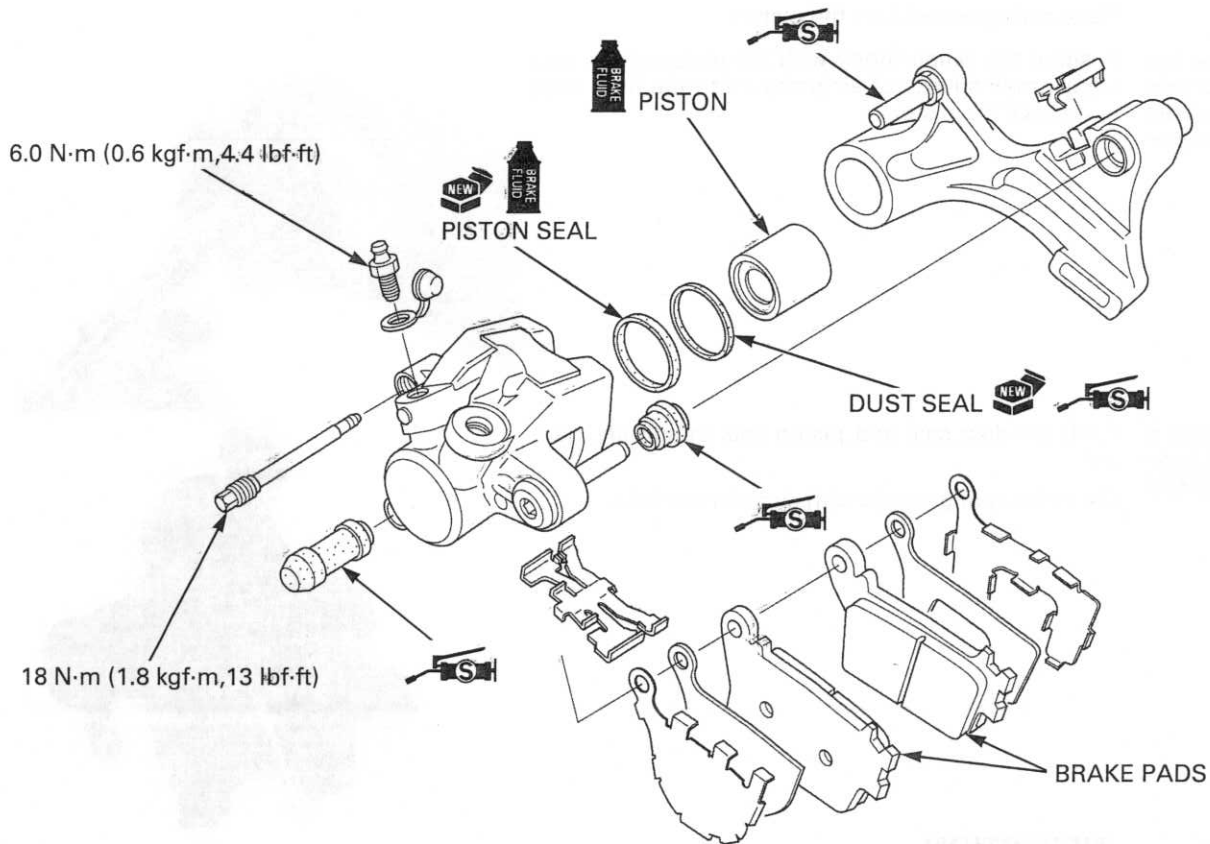

Coat a new piston seal with clean brake fluid.
Coat a new dust seal with silicone grease.

Install the piston seal and dust seal into the groove of the caliper body.

Coat the caliper piston with clean brake fluid and install it into the caliper cylinder with its open end toward the pad.

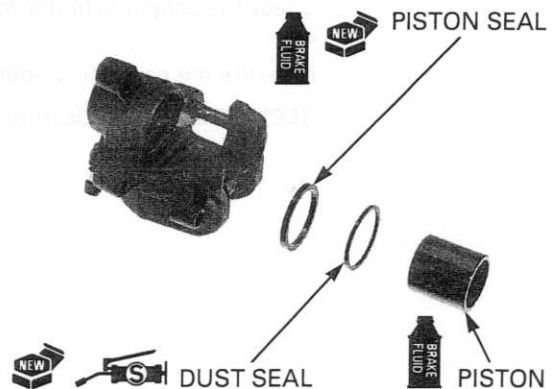

Install the retainer onto the caliper bracket.
 Install the pad spring into the caliper body.
 If boot is hard or deteriorated, replace it with a new one.
 Apply silicone grease to the inside of the boot and its sliding surface.
 Install the caliper cylinder onto the caliper bracket.

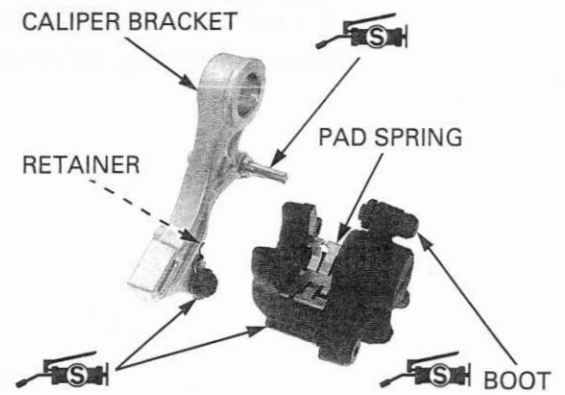

INSTALLATION

Install the rear wheel (page 15-13).
 Install the brake hose eyelet joint to the caliper body with new sealing washers and oil bolt.
 Push the brake hose eyelet joint to the stopper on the caliper, then tighten the oil bolt to the specified torque.

TORQUE: 34 N·m (3.5 kgf·m, 25 lbf·ft)

Install the rear brake pads.
 Fill brake fluid and bleed air from the rear brake hydraulic system (page 16-8).

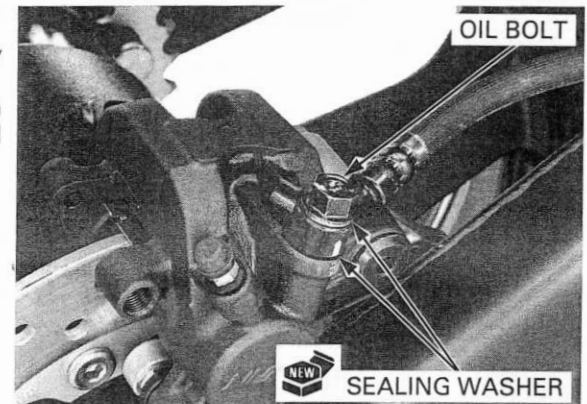

BRAKE PEDAL

REMOVAL

Unhook the rear brake light switch spring from the brake pedal.
 Remove the rear brake light switch from the main step bracket.

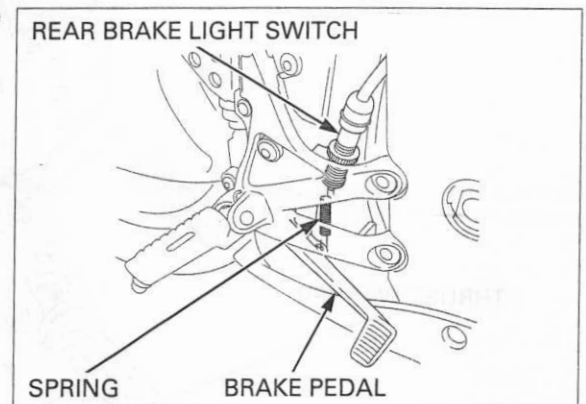

Remove the muffler guard bolt, heat guard bolt, washer, main step bracket mounting bolts and bracket assembly from the frame.

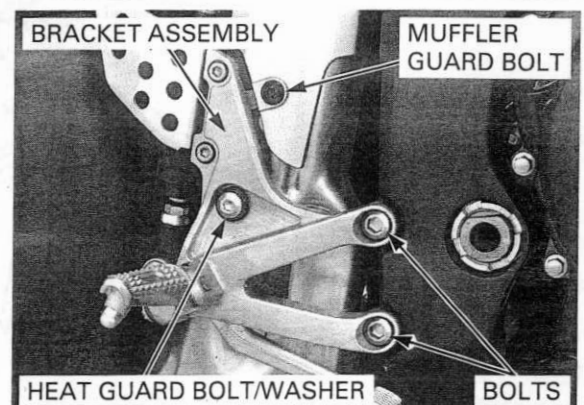

HYDRAULIC BRAKE

Remove the cotter pin, nut, bolt, washers and disconnect the push rod from the brake pedal.

Unhook the brake pedal return spring.

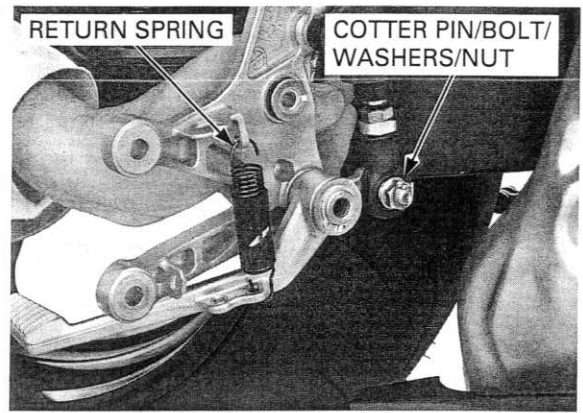

Remove the snap ring, thrust washer, and wave washer.

Remove the brake pedal from the main step bracket.

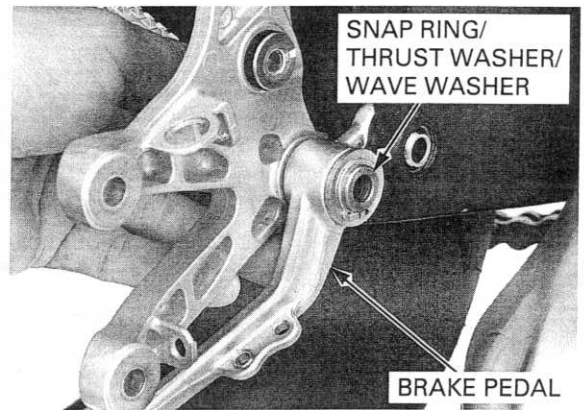

INSTALLATION

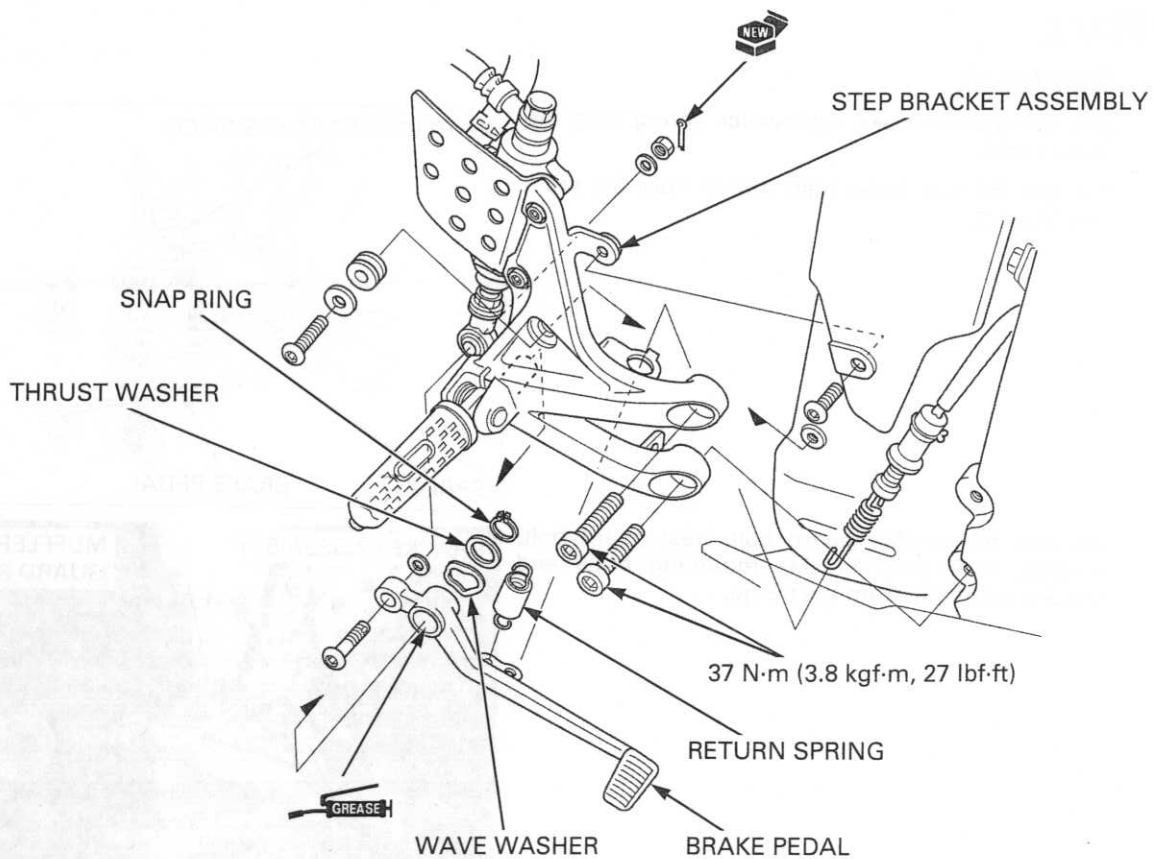

Apply grease to the brake pedal sliding surface. Install the brake pedal, wave washer, and thrust washer onto the main step bracket.

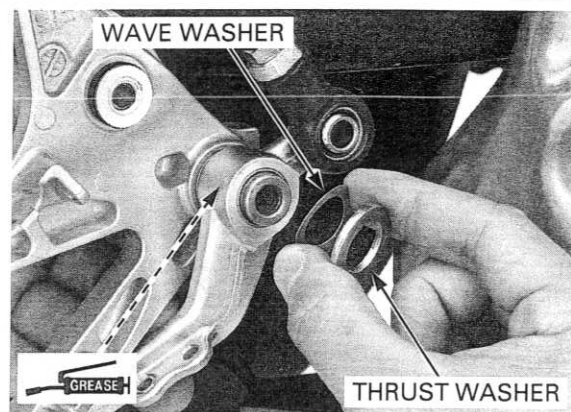

After installing a snap ring, always rotate it in its groove to be sure it is fully seated.

Install the snap ring securely.

Hook the brake pedal return spring.

Install the bolt, washers, nut and tighten the nut securely.

Install a new cotter pin securely.

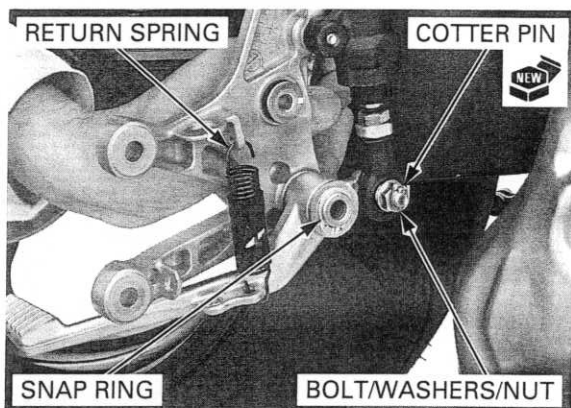

Install the main step bracket assembly onto the frame. Tighten the main step bracket mounting bolts to the specified torque.

TORQUE: 37 N-m (3.8 kgf-m, 27 lbf-ft)

Tighten the muffler guard bolt securely.

Install the washer and heat guard bolt, tighten the heat guard bolt securely.

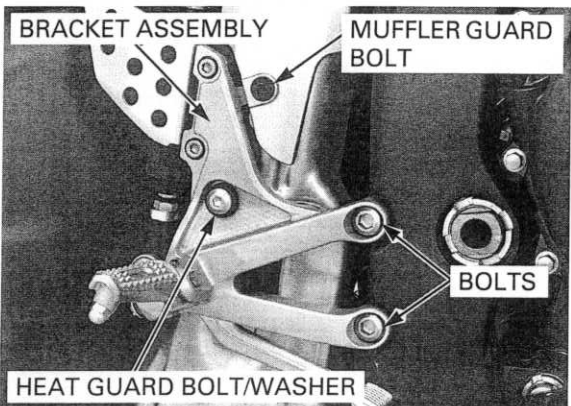

Install the rear brake light switch.

Hook the rear brake light switch spring to the brake pedal.

Adjust the rear brake light switch operation (page 4-31).

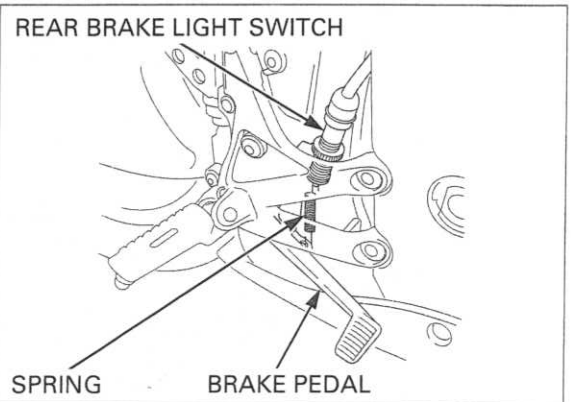

MEMO

17. BATTERY/CHARGING SYSTEM

SYSTEM DIAGRAM.....	17-2	CHARGING SYSTEM INSPECTION.....	17-7
SERVICE INFORMATION	17-3	ALTERNATOR CHARGING COIL	17-8
TROUBLESHOOTING	17-5	REGULATOR/RECTIFIER	17-8
BATTERY.....	17-6		

BATTERY/CHARGING SYSTEM

SYSTEM DIAGRAM

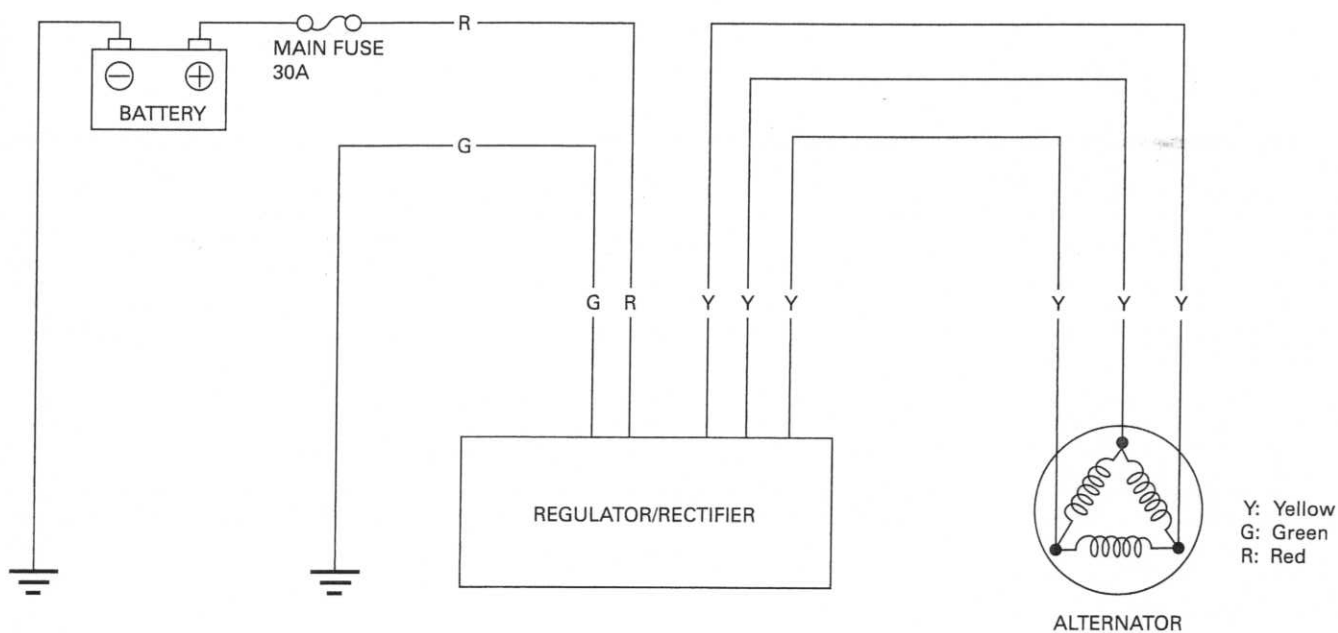
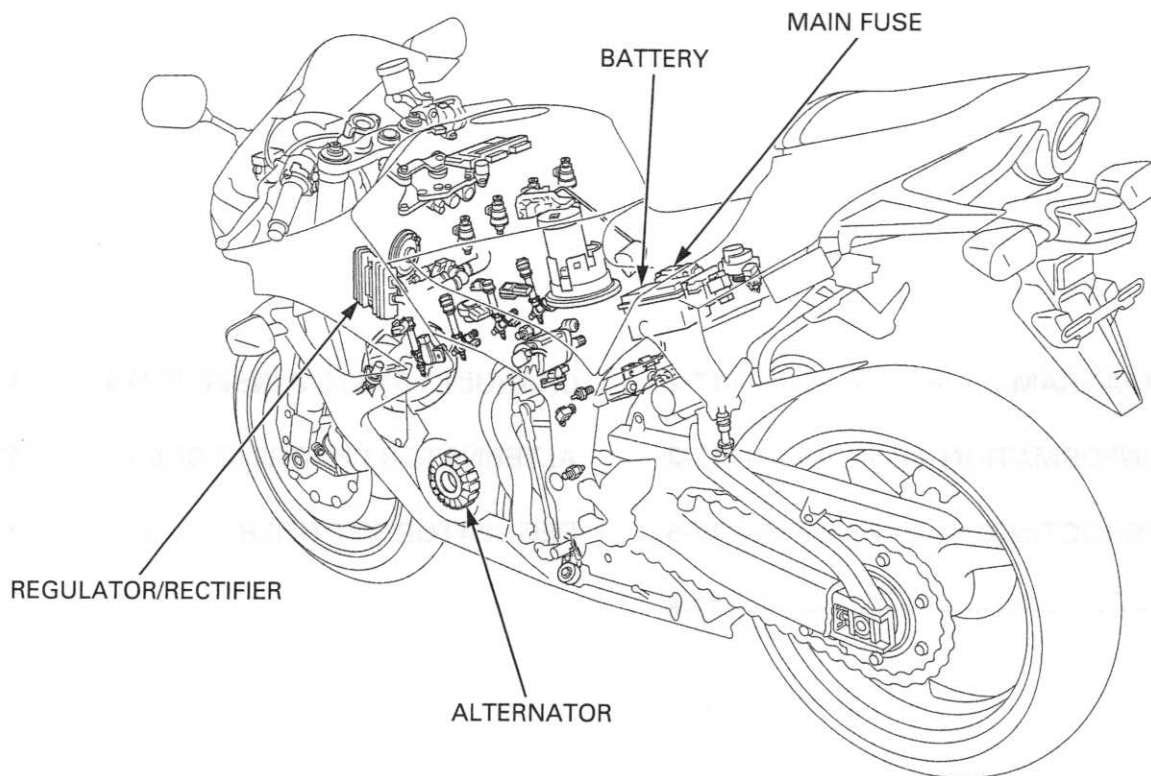

SERVICE INFORMATION

GENERAL

⚠ WARNING

- The battery gives off explosive gases; keep sparks, flames and cigarettes away. Provide adequate ventilation when charging.
- The battery contains sulfuric acid (electrolyte). Contact with skin or eyes may cause severe burns. Wear protective clothing and a face shield.
 - If electrolyte gets on your skin, flush with water.
 - If electrolyte gets in your eyes, flush with water for at least 15 minutes and call a physician immediately.
- Electrolyte is poisonous.
 - If swallowed, drink large quantities of water or milk and call your local Poison Control Center or a call a physician immediately.

NOTICE

- *Always turn OFF the ignition switch before disconnecting any electrical component.*
- *Some electrical components may be damaged if terminals or connectors are connected or disconnected while the ignition switch is ON and current is present.*
- For extended storage, remove the battery, give it a full charge, and store it in a cool, dry space. For maximum service life, charge the stored battery every two weeks.
- For a battery remaining in a stored motorcycle, disconnect the negative battery cable from the battery terminal.
- The maintenance free battery must be replaced when it reaches the end of its service life.
- The battery can be damaged if overcharged or undercharged, or if left to discharge for a long period. These same conditions contribute to shortening the "life span" of the battery. Even under normal use, the performance of the battery deteriorates after 2–3 years.
- Battery voltage may recover after battery charging, but under heavy load, battery voltage will drop quickly and eventually die out. For this reason, the charging system is often suspected as the problem. Battery overcharge often results from problems in the battery itself, which may appear to be an overcharging symptom. If one of the battery cells is shorted and battery voltage does not increase, the regulator/rectifier supplies excess voltage to the battery. Under these conditions, the electrolyte level goes down quickly.
- Before troubleshooting the charging system, check for proper use and maintenance of the battery. Check if the battery is frequently under heavy load, such as having the headlight and taillight on for long periods of time without riding the motorcycle.
- The battery will self-discharge when the motorcycle is not in use. For this reason, charge the battery every two weeks to prevent sulfation from occurring.
- When checking the charging system, always follow the steps in the troubleshooting flow chart (page 17-5).
- For battery charging, do not exceed the charging current and time specified on the battery. Use of excessive current or charging time may damage the battery.
- For alternator removal (page 11-4).

BATTERY CHARGING

- Turn power ON/OFF at the charger, not at the battery terminal.
- For battery charging, do not exceed the charging current and time specified on the battery. Using excessive current or extending the charging time may damage the battery.
- Quick charging should only be done in an emergency; slow charging is preferred.

BATTERY TESTING

Refer to the instruction in the Operation Manual for the recommended battery tester for details about battery testing. The recommended battery tester puts a "load" on the battery so that the actual battery condition can be measured.

Recommended battery tester: Micro 404XL (U.S.A. only), BM-210 or equivalent

SPECIFICATIONS

ITEM		SPECIFICATIONS	
Battery	Capacity	12V – 8.6 Ah	
	Current leakage	2.0 mA max.	
	Voltage (20°C/68°F)	Fully charged	13.0 – 13.2 V
		Needs charging	Below 12.4 V
	Charging current	Normal	0.9 A/5 – 10 h
Quick		4.5 A/1 h	
Alternator	Capacity	0.342 kW/5,000 rpm	
	Charging coil resistance (20°C/68°F)	0.1 – 1.0 Ω	

BATTERY/CHARGING SYSTEM

TOOLS

Motorcycle battery analyzer
Micro 404XL (U.S.A. only)



Christie battery charger
MC1012/2T (U.S.A. only)

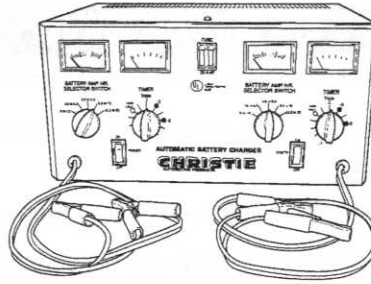

TROUBLESHOOTING

BATTERY IS DAMAGED OR WEAK

1. BATTERY TEST

Remove the battery (page 17-6).

Check the battery condition using the recommended battery tester.

Recommended battery tester: Micro 404XL (U.S.A. only), BM-210 or equivalent

Is the battery in good condition?

NO – Faulty battery

YES – GO TO STEP 2.

2. CURRENT LEAKAGE TEST

Install the battery (page 17-6).

Check the battery current leakage test (page 17-7).

Is the current leakage below 2.0 mA?

YES – GO TO STEP 4.

NO – GO TO STEP 3.

3. CURRENT LEAKAGE TEST WITHOUT REGULATOR/RECTIFIER CONNECTED

Disconnect the regulator/rectifier connector and recheck the battery current leakage.

Is the current leakage below 2.0 mA?

YES – Faulty regulator/rectifier

NO – • Shorted wire harness
• Faulty ignition switch

4. ALTERNATOR CHARGING COIL INSPECTION

Check the alternator charging coil (page 17-8).

Is the alternator charging coil resistance within 0.1 – 1.0 Ω (20°C/68°F)?

NO – Faulty charging coil

YES – GO TO STEP 5.

5. CHARGING VOLTAGE INSPECTION

Measure and record the battery voltage using a digital multimeter (page 17-6).

Start the engine.

Measure the charging voltage (page 17-7).

Compare the measurement to result of the following calculation.

Standard:

Measured BV < Measured CV < 15.5 V

• **BV = Battery Voltage (page 17-6)**

• **CV = Charging Voltage (page 17-7)**

Is the measured charging voltage within the standard voltage?

YES – Faulty battery

NO – GO TO STEP 6.

6. REGULATOR/RECTIFIER SYSTEM INSPECTION

Check the voltage and resistance at the regulator/rectifier connector (page 17-8).

Are the results of checked voltage and resistance correct?

YES – Faulty regulator/rectifier

NO – • Open circuit in related wire
• Loose or poor contacts of related terminal

BATTERY/CHARGING SYSTEM

BATTERY

REMOVAL/INSTALLATION

Always turn the ignition switch OFF before removing the battery.

Remove the seat (page 3-4).

Disconnect the negative cable and then the positive cable.

Remove the battery holder band and battery.

Install the battery in the reverse order of removal.

After installing the battery, coat the terminals with clean grease.

Connect the positive terminal first and then the negative cable.

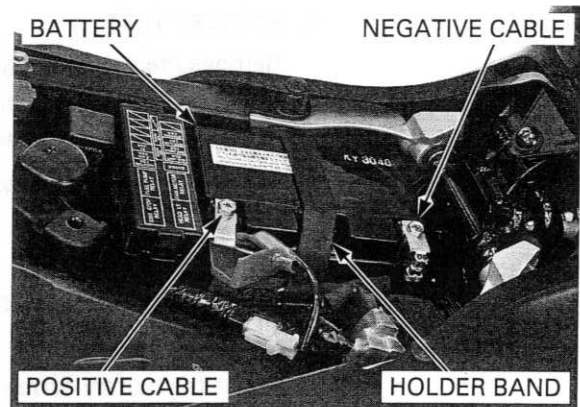

VOLTAGE INSPECTION

Measure the battery voltage using a digital multimeter.

VOLTAGE:

Fully charged: 13.0 – 13.2V

Under charged: Below 12.4V

TOOL:

Digital multimeter **Commercially available**



BATTERY TESTING

Remove the battery (page 17-6).

Refer to the instructions that are appropriate to the battery testing equipment available to you.

TOOL:

Battery tester **Micro 404XL (U.S.A. only),
BM-210 or equivalent**

BATTERY CHARGING (U.S.A. only)

Remove the battery (page 17-6).

Refer to the instructions that are appropriate to the battery charging equipment available to you.

TOOL:

Christie battery charger **MC1012/2T (U.S.A. only)**

CHARGING SYSTEM INSPECTION

CURRENT LEAKAGE INSPECTION

Remove the seat (page 3-4).

Turn the ignition switch OFF and disconnect the battery negative cable from the battery.

Connect the ammeter (+) probe to the negative (-) cable and ammeter (-) probe to the battery (-) terminal.

With the ignition switch OFF, check for current leakage.

- When measuring current using a tester, set it to a high range, and then bring the range down to an appropriate level. Current flow higher than the range selected may blow out the fuse in the tester.
- While measuring current, do not turn the ignition switch ON. A sudden surge of current may blow out the fuse in the tester.

SPECIFIED CURRENT LEAKAGE: 2.0 mA max.

If current leakage exceeds the specified value, a short circuit is likely.

Locate the shorted circuit by disconnecting connections one by one and measuring the current.

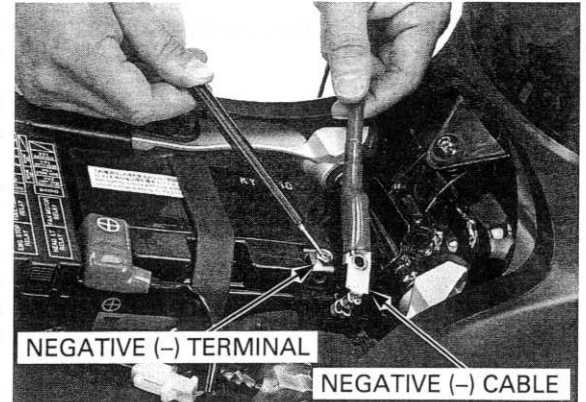

CHARGING VOLTAGE INSPECTION

Be sure the battery is in good condition before performing this test.

Do not disconnect the battery or any cable in the charging system without first switching OFF the ignition switch. Failure to follow this precaution can damage the tester or electrical components.

Warm the engine to normal operating temperature. Stop the engine, and connect the multimeter between the positive and negative terminals of the battery.

- To prevent a short, make absolutely certain which are the positive and negative terminals or cable.

Restart the engine.

With the headlight on Hi beam, measure the voltage on the multimeter when the engine runs at 5,000 rpm.

Standard:

**Measured BV < Measured CV < 15.5 V
at 5,000 rpm**

BV = Battery Voltage (page 17-6)

CV = Charging Voltage



BATTERY/CHARGING SYSTEM

ALTERNATOR CHARGING COIL

INSPECTION

Remove the left middle cowl (page 3-8).

It is not necessary to remove the stator coil to make this test.

Disconnect the alternator 3P (Natural) connector.

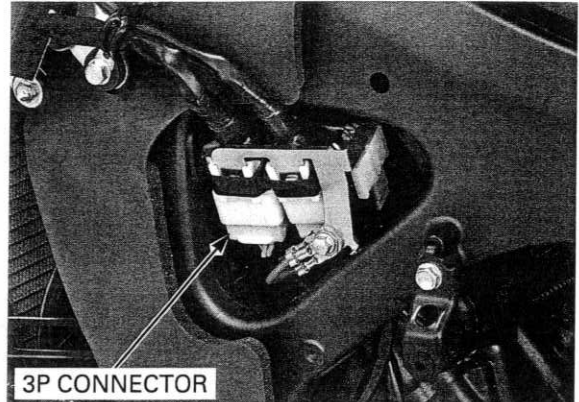

Measure the resistance between all Yellow terminals.

Standard: 0.1 – 1.0 Ω (at 20°C/68°F)

Check for continuity between all Yellow terminals and ground.

There should be no continuity.

If readings are far beyond the standard, or if any wire has continuity to ground, replace the stator. For alternator removal (page 11-4).

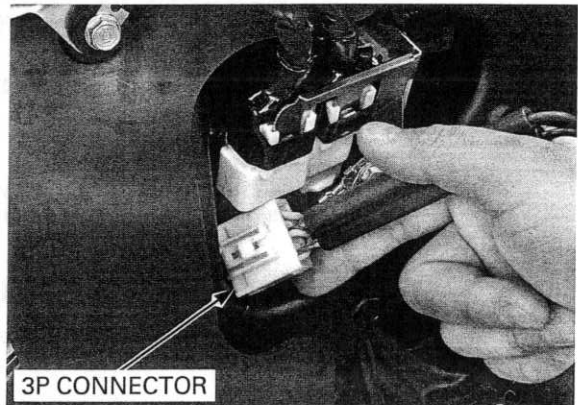

REGULATOR/RECTIFIER

SYSTEM INSPECTION

It is not necessary to remove the stator coil to perform this test.

Remove the left middle cowl (page 3-8).

Disconnect the regulator/rectifier 2P (Natural) connector and alternator 3P (Natural) connector, and check it for loose contact or corroded terminals.

If the regulated voltage reading (page 17-3) is out of the specification, measure the voltage between connector terminals (wire side) as follows:

ITEM	TERMINAL	SPECIFICATION
Battery charging line	Red (+) and ground (-)	Battery voltage should appear
Charging coil line	Yellow and Yellow	0.1 – 1.0 Ω at (20°C/68°F)
Ground line	Green and ground	Continuity should exist

If all components of the charging system are normal and there are no loose connections at the regulator/rectifier connectors, replace the regulator/rectifier unit.

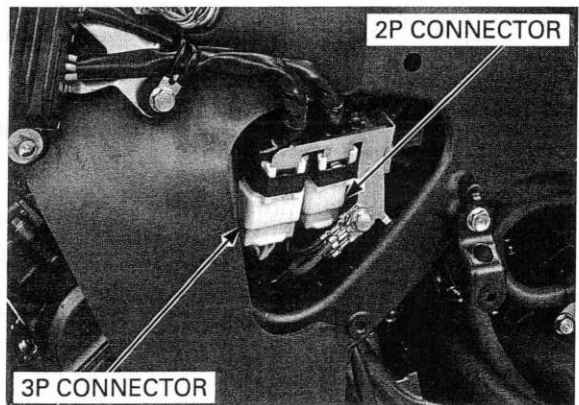

REMOVAL/INSTALLATION

Remove the left middle cowl (page 3-8).

Disconnect the alternator 3P (Natural) connector.
Disconnect the regulator/rectifier 2P (Natural) connector.

Remove the bolts, washers, wire clamp and regulator/rectifier unit stay.

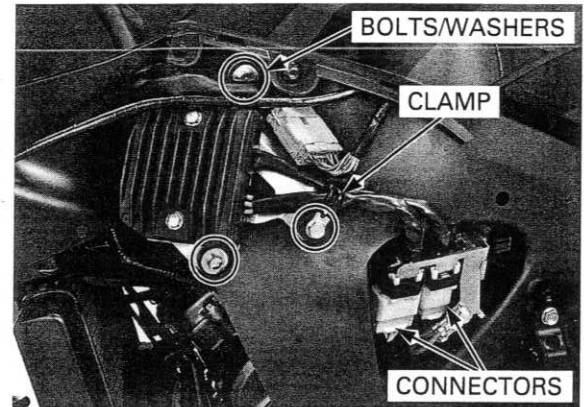

Remove the bolts, nuts and regulator/rectifier unit from the stay.

Installation is in the reverse order of removal.

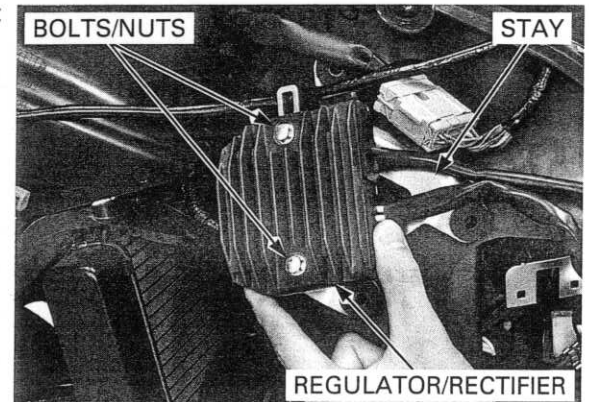

MEMO

[Faint, illegible text in the left margin]

[Faint, illegible text in the main body of the page]

18. IGNITION SYSTEM

SYSTEM DIAGRAM.....	18-2	IGNITION SYSTEM INSPECTION.....	18-5
SERVICE INFORMATION	18-3	CKP SENSOR.....	18-7
TROUBLESHOOTING.....	18-4	IGNITION TIMING	18-7

IGNITION SYSTEM SYSTEM DIAGRAM

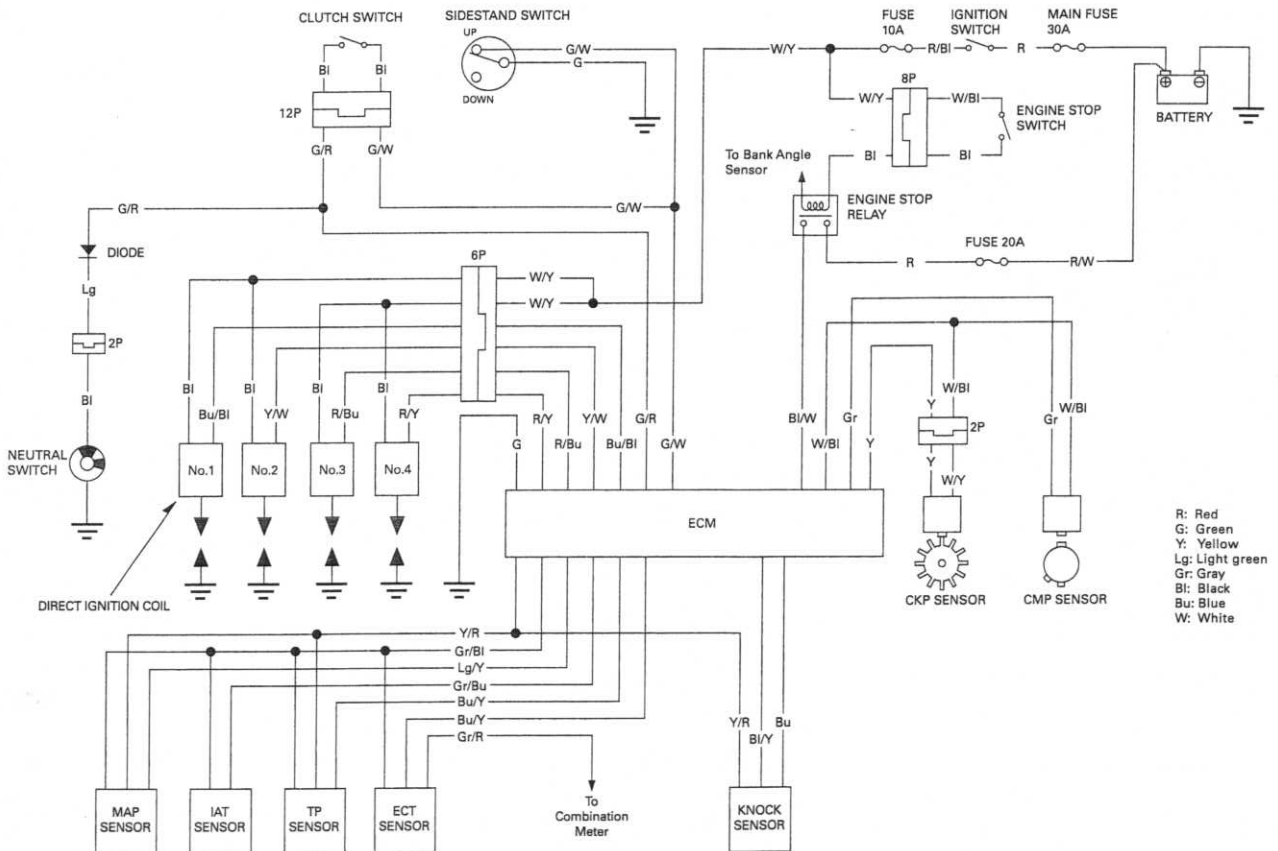
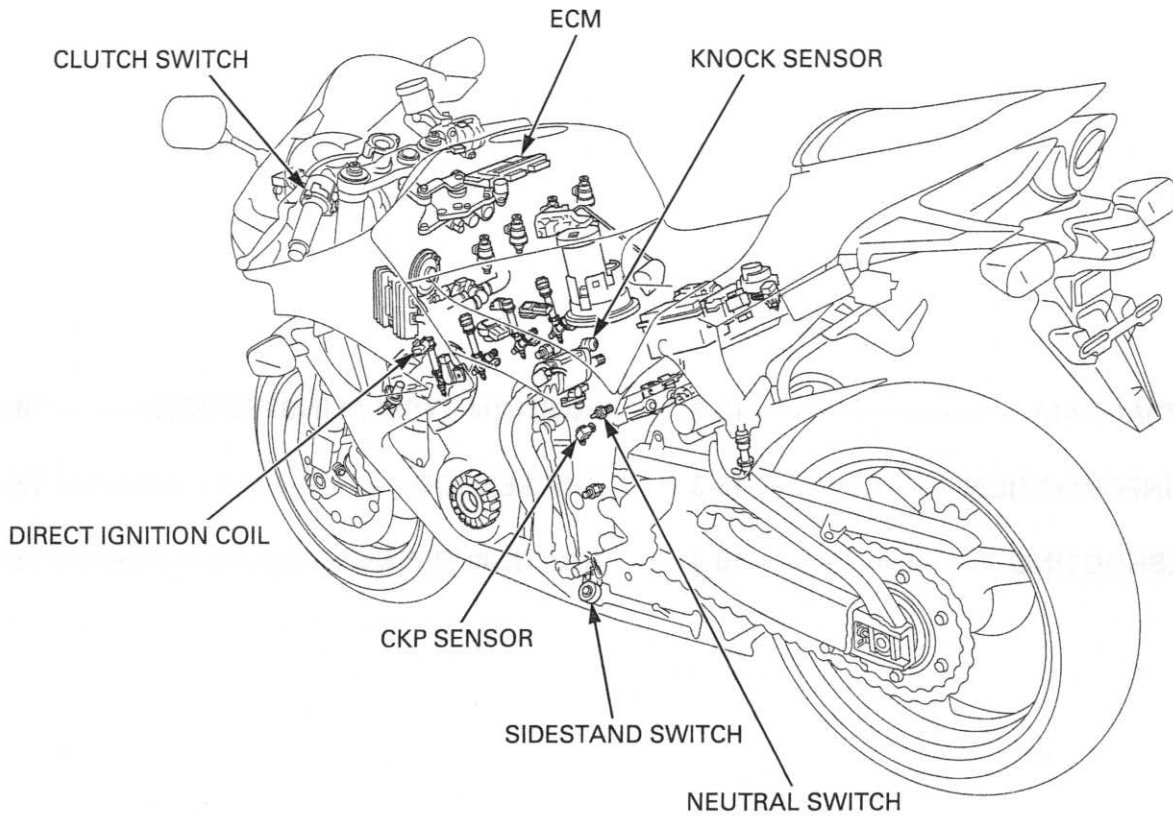

SERVICE INFORMATION

GENERAL

NOTICE

- The ECM may be damaged if dropped. Also if the connector is disconnected when current is flowing, the excessive voltage may damage the module. Always turn off the ignition switch before servicing.
- Use spark plug of the correct heat range. Using spark plug with an incorrect heat range can damage the engine.
- Some electrical components may be damaged if terminals or connectors are connected or disconnected while the ignition switch is ON and current is present.
- When servicing the ignition system, always follow the steps in the troubleshooting sequence (page 18-4).
- This motorcycle's ICM is built into the ECM.
- The ignition timing does not normally need to be adjusted since the ECM is factory preset.
- A faulty ignition system is often related to poor connections. Check those connections before proceeding. Make sure the battery is adequately charged. Using the starter motor with a weak battery results in a slower engine cranking speed as well as no spark at the spark plug.
- This motorcycle features direct ignition coils, where the ignition coil and spark plug cap are integrated. There are four direct ignition coils.
- For PGM-FI troubleshooting information (page 6-13).
- The following components information
 - Ignition switch (page 20-17)
 - Sidestand switch (page 20-20)
 - Clutch switch (page 20-19)
 - Neutral switch (page 20-20)

SPECIFICATIONS

ITEM		SPECIFICATIONS
Spark plug (Iridium)	NGK	IMR9C-9HES
	DENSO	VUH27D
Spark plug gap		0.80 – 0.90 mm (0.031 – 0.035 in)
CKP sensor peak voltage		0.7 V minimum
Ignition timing ("F"mark)		7.8° BTDC at idle

TORQUE VALUE

Timing hole cap

18 N·m (1.8 kgf·m, 13 lbf·ft)

Apply grease to the threads

TOOLS

Peak voltage adaptor
07HGJ-0020100 (Not available in
U.S.A.)

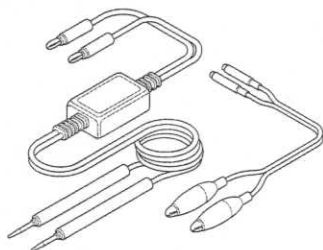

with commercially available digital
multimeter (impedance 10 MΩ/DCV
minimum)

Test probe
07ZAJ-RDJA110

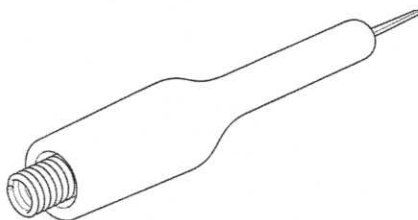

IgnitionMate peak voltage tester
MTP07-0286 (U.S.A. only)

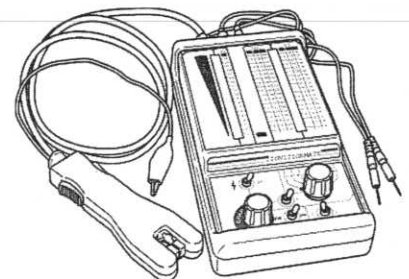

IGNITION SYSTEM

TROUBLESHOOTING

- Inspect the following before diagnosing the system.
 - Faulty spark plug
 - Loose direct ignition coil and spark plug connection
 - Loose direct ignition coil connectors
 - Water got into the direct ignition coil (shorting the ignition coil secondary voltage)
- If there is no spark at one cylinder, temporarily exchange the direct ignition coil with the other good one and perform the spark test. If there is spark, the original direct ignition coil is faulty.
- "Initial voltage" of the ignition primary coil is battery voltage with the ignition switch turned ON and engine stop switch turned "O" (The engine is not cranked by the starter motor).

No spark at all plugs

Unusual condition		Probable cause (Check in numerical order)
Ignition coil primary voltage	No initial voltage with the ignition switch ON and engine stop switch turned "O" (other electrical components are normal)	<ol style="list-style-type: none"> 1. Faulty engine stop switch 2. Loose or poor connect of the direct ignition coil primary wire terminal, or an open circuit in primary coil (Check at the ECM connector) 3. Faulty ECM (in case when the initial voltage is normal while disconnecting ECM connector)
	Initial voltage is normal, but it drops down to 2 – 4 V while cranking the engine.	<ol style="list-style-type: none"> 1. Undercharged battery 2. An open circuit or loose connection in ECM Green wire 3. An open circuit or loose connection in Blue/black, Yellow/white, Red/blue and Red/yellow wires between the direct ignition coils and ECM 4. Faulty sidestand switch, clutch switch or neutral switch. 5. An open circuit or loose connection in No. 4 related circuit wires <ul style="list-style-type: none"> – Clutch switch line: Green/white wire – Sidestand switch line: Green/white wire – Neutral switch line: Light green wire 6. Faulty CKP sensor (measure the peak voltage). 7. Faulty ECM (in case when above No. 1 – 7 are normal). 8. Faulty direct ignition coil
	Initial voltage is normal, but does not spark.	<ol style="list-style-type: none"> 1. Faulty spark plug or leaking ignition coil secondary current ampere. 2. Faulty direct ignition coil (s)
CKP sensor	Peak voltage is lower than standard value.	<ol style="list-style-type: none"> 1. The multimeter impedance is too low; below 10 MΩ/DCV. 2. Cranking speed is too low (battery under charged). 3. The sampling timing of the tester and measured pulse were not synchronized (system is normal if measured voltage is over the standard voltage at least once). 4. Faulty CKP sensor (in case when above No. 1 – 3 are normal)
	No peak voltage.	<ol style="list-style-type: none"> 1. Faulty peak voltage adaptor 2. Faulty CKP sensor 3. Faulty CMP sensor

IGNITION SYSTEM INSPECTION

- If there is no spark at any plug, check all connections for loose or poor contact before measuring each peak voltage.
- Use the recommended digital multimeter or commercially available digital multimeter with an impedance of 10 MΩ/DCV minimum.
- The display value differs depending upon the internal impedance of the multimeter.
- If the peak voltage tester (U.S.A. only) is used, follow the manufacturer's instruction.

Connect the peak voltage tester or peak voltage adaptor to the digital multimeter.

TOOL:

IgnitionMate peak voltage tester MTP07-0286 (U.S.A. only) or 07HGJ-0020100 (Not available in U.S.A.)

Peak voltage adaptor

with commercially available digital multimeter (impedance 10 MΩ/DCV minimum)

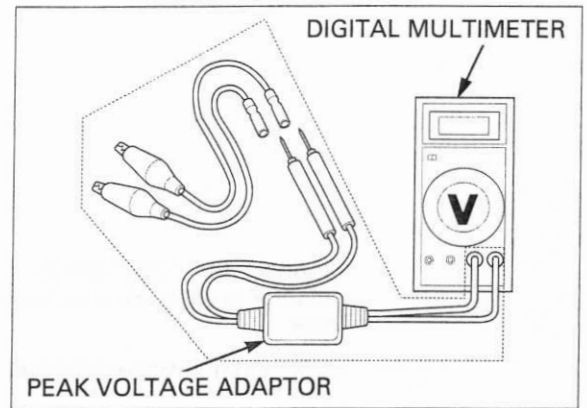

IGNITION COIL INITIAL VOLTAGE

- Check all system connections before inspection. If the system is disconnected, incorrect initial voltage might be measured.
- Check cylinder compression and check that the spark plugs are installed correctly.

Disconnect the direct ignition coils from the spark plugs (page 4-9).

Connect the direct ignition coil 2P (White) connectors to the direct ignition coil.

Shift the transmission into neutral.

Connect a known-good spark plug to the direct ignition coil and ground the spark plug to the cylinder head as done in a spark test.

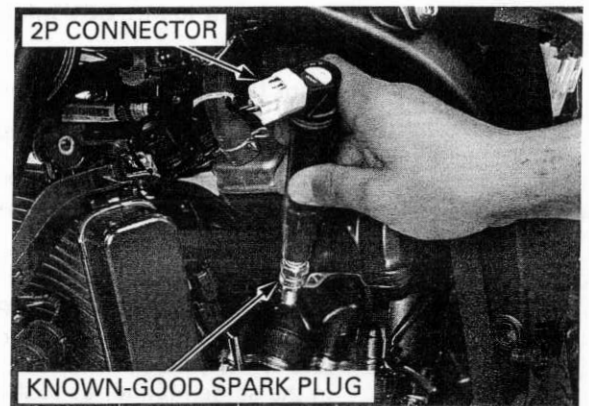

Disconnect the direct ignition coil 2P (White) connector.

Turn the ignition switch ON and engine stop switch "O".

Measure the initial voltage.

Connection: Black (+) – Ground (-)

Standard: Battery voltage

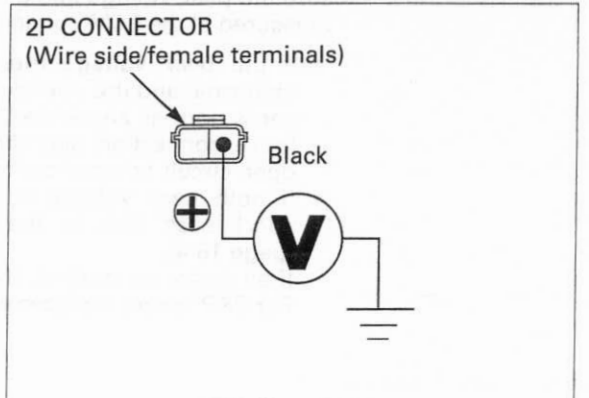

IGNITION SYSTEM

CKP SENSOR PEAK VOLTAGE

- Check all system connections before inspection. If the system is disconnected, incorrect peak voltage might be measured.
- Check cylinder compression and check that the spark plugs are installed correctly.

Remove the fuel tank cover (page 3-9).

Disconnect the ECM 33P (Gray) connector from the ECM.

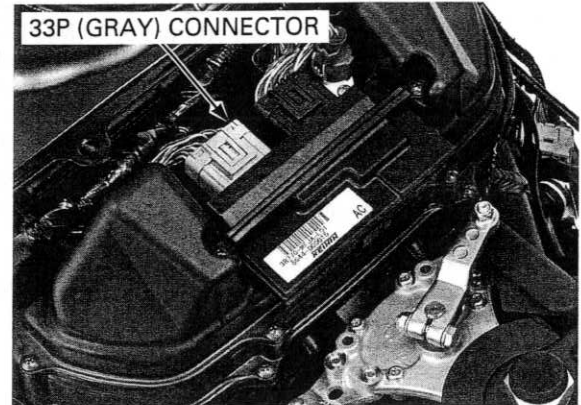

Connect the peak voltage tester or peak voltage adaptor probes to the connector terminal of the wire side.

Connection: Yellow terminal (+) – Ground (-)

TOOLS:

IgnitionMate peak voltage tester MTP07-0286
(U.S.A. only) or 07HGJ-0020100
(Not available in U.S.A.)

Peak voltage adaptor

with commercially available digital multimeter
(impedance 10 M Ω /DCV minimum)

Test probe 07ZAJ-RDJA110

Crank the engine and read the peak voltage.

PEAK VOLTAGE: 0.7 V minimum

If the peak voltage measured at ECM connector is abnormal, measure the peak voltage at the CKP sensor connector.

Lift and support the fuel tank (page 4-5).

Disconnect the CKP sensor 2P (Black) connector and connect the tester probes to the terminal (Yellow and White/yellow).

In the same manner as at the ECM connector, measure the peak voltage and compare it to the voltage measured at the ECM connector.

- If the peak voltage measured at the ECM is abnormal and the one measured at the CKP sensor is normal, check the 2P (Black) connector for loose connection and the wire harness for an open circuit or loose connection.
- If both peak voltage measured are abnormal, check each item in the troubleshooting chart (page 18-4).

If all items are normal, the CKP sensor is faulty. For CKP sensor replacement (page 18-7).

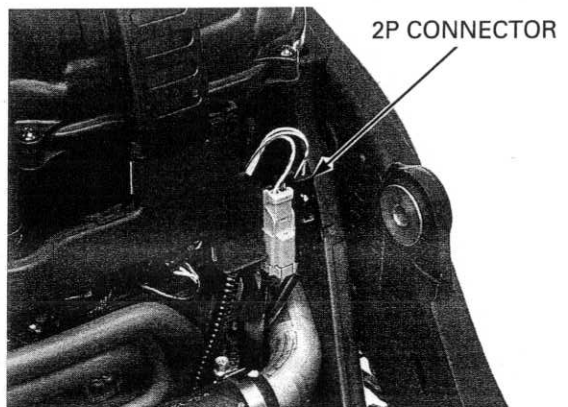
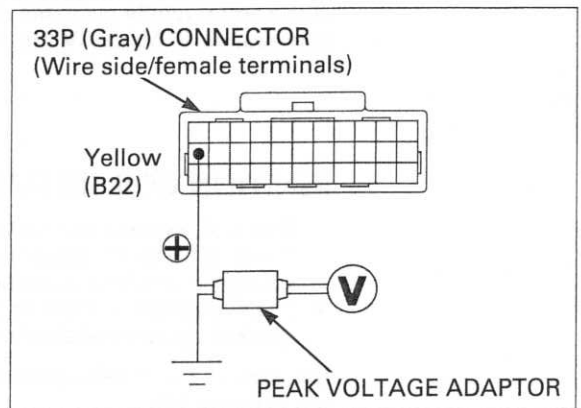

CKP SENSOR

REMOVAL/INSTALLATION

Remove the right crankcase cover (page 10-5).

Remove the wire grommet from the cover.
Remove the bolts and CKP sensor.

Apply sealant to the grommet seating surface.
Install the CKP sensor and grommet to the cover groove properly.
Tighten the bolts securely.

Install the right crankcase cover (page 10-26).

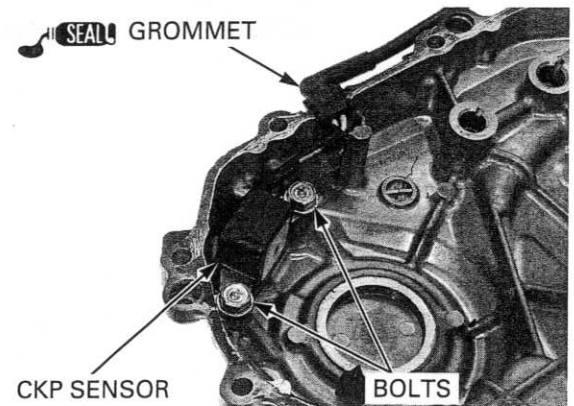

IGNITION TIMING

Warm up the engine.

Stop the engine and remove the timing hole cap.

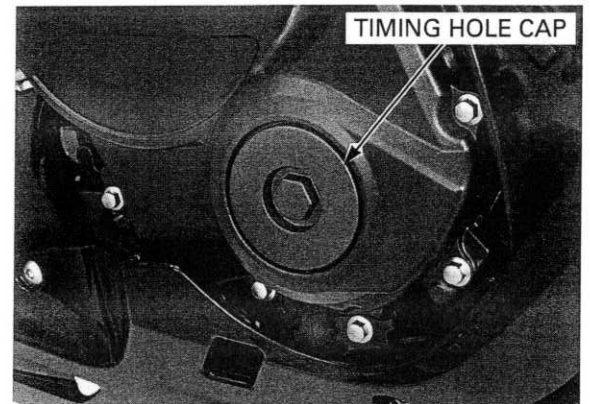

Read the instructions for timing light operation.

Connect the timing light to the No.1 direct ignition coil connector wire.

Start the engine, let it idle and check the ignition timing.

IDLE SPEED: 1,400 ± 100 rpm

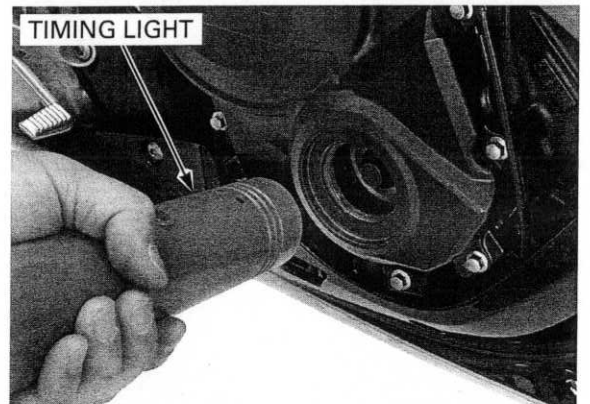

The ignition timing is correct if the index mark on the right crankcase cover aligns the "F" mark on the CKP sensor rotor as shown.

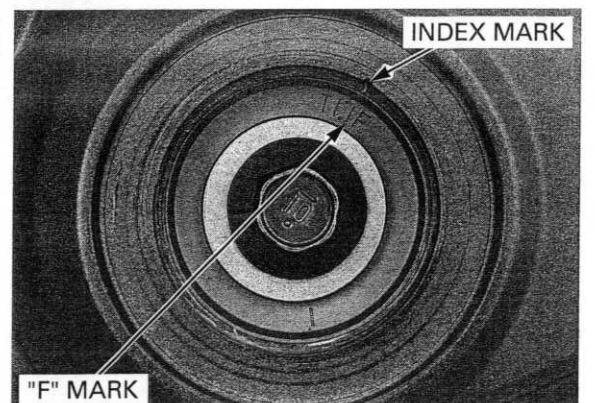

IGNITION SYSTEM

Apply oil to a new O-ring and install it to the timing hole cap.

Apply grease to the timing hole cap threads and tighten the timing hole cap to the specified torque.

TORQUE: 18 N·m (1.8 kgf·m, 13 lbf·ft)

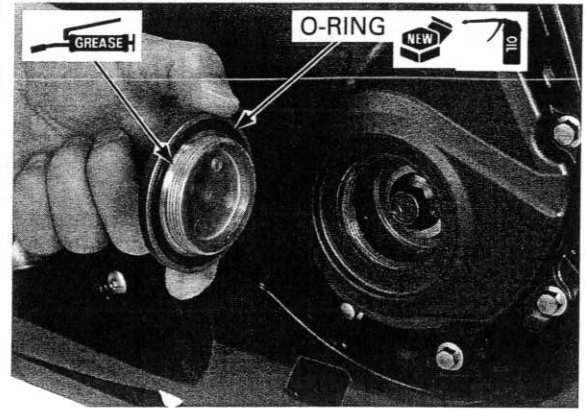

19. ELECTRIC STARTER

SYSTEM DIAGRAM.....	19-2	STARTER MOTOR.....	19-6
SERVICE INFORMATION	19-3	STARTER RELAY SWITCH.....	19-14
TROUBLESHOOTING	19-4	DIODE.....	19-16



ELECTRIC STARTER

SYSTEM DIAGRAM

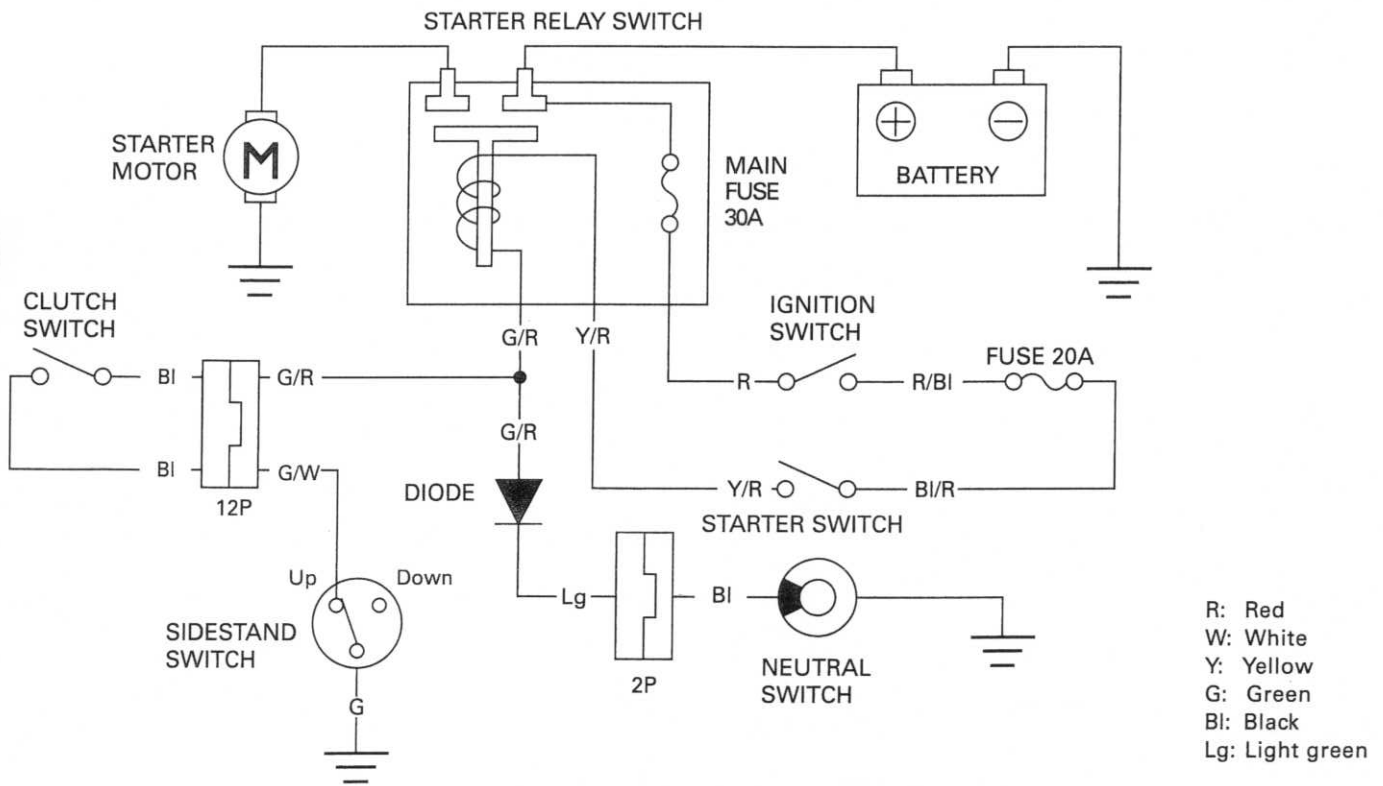
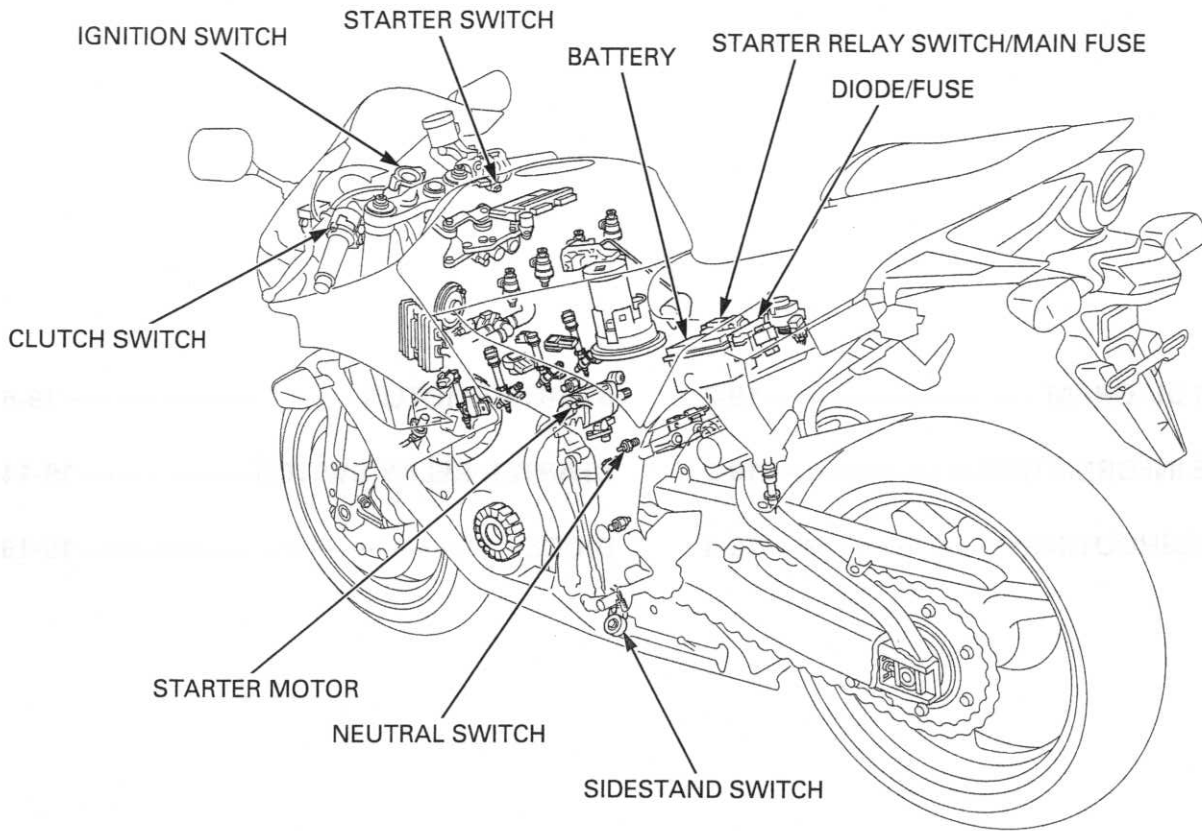

SERVICE INFORMATION

GENERAL

NOTICE

If current is kept flowing through the starter motor to turn it while the engine is not cranking over, the starter motor may be damaged.

- Always turn the ignition switch OFF before servicing the starter motor. The motor could suddenly start, causing serious injury.
- The starter motor can be serviced with the engine in the frame.
- When checking the starter system, always follow the steps in the troubleshooting flow chart (page 19-4).
- A weak battery may be unable to turn the starter motor quickly enough, or supply adequate ignition current.
- For the starter clutch servicing (page 10-17).
- Refer to the following components information.
 - Ignition switch (page 20-17)
 - Starter switch (page 20-17)
 - Neutral switch (page 20-20)
 - Sidestand switch (page 20-20)
 - Clutch switch (page 20-19)

SPECIFICATION

Unit: mm (in)

ITEM	STANDARD	SERVICE LIMIT
Starter motor brush length	12.0 (0.47)	6.5 (0.26)

TORQUE VALUE

Starter motor terminal nut 10 N·m (1.0 kgf-m, 7 lbf-ft)

TROUBLESHOOTING

Starter motor does not turn

1. Fuse Inspection

Check for blown main fuse or sub fuse (HEADLIGHT 20 A).

Is the fuse blown?

YES – Replace the fuse

NO – GO TO STEP 2.

2. Battery Inspection

Make sure the battery is fully charged and in good condition.

Is the battery in good condition?

YES – GO TO STEP 3.

NO – Replace the battery

3. Starter Relay Switch Operation

Check the starter relay switch operation.

You should hear the relay "CLICK" when the starter switch button is depressed.

Is there a "CLICK"?

YES – GO TO STEP 4.

NO – GO TO STEP 5.

4. Starter Motor Inspection

Apply battery voltage to the starter motor directly and check the operation.

Does the starter motor turn?

YES –

- Poorly connected starter motor cable
- Faulty starter relay switch (page 19-14)

NO – Faulty starter motor (page 19-6)

5. Relay Coil Ground Wire Lines Inspection

Disconnect the starter relay switch connector, and check the relay coil ground wire lines as below for continuity:

1. Green/red terminal – diode – neutral switch line (with the transmission in neutral and clutch lever released).
2. Green/red terminal – clutch switch – sidestand switch line (in any gear except neutral, and with the clutch lever pulled in and sidestand up).

Is there continuity?

NO –

- Faulty neutral switch (page 20-20)
- Faulty diode (page 19-16)
- Faulty clutch switch (page 20-19)
- Faulty sidestand switch (page 20-20)
- Loose or poor contact connector
- Open circuit in wire harness

YES – GO TO STEP 6.

6. Starter Relay Voltage Inspection

Connect the starter relay switch connector.

With the ignition switch ON and starter switch pushed, measure the voltage at the starter relay switch connector (between Yellow/red (+) and body ground (-)).

Is the starter relay switch operation correct?

NO –

- Faulty ignition switch (page 20-17)
- Faulty starter switch (page 20-17)
- Loose or poor contact connector
- Open circuit in wire harness

YES – GO TO STEP 7.

7. Starter Relay Switch Continuity Inspection

Connect the starter relay switch connector.

Turn the ignition switch ON and check for continuity at the starter relay switch terminals when the starter switch is pushed.

Is there continuity?

NO – Faulty starter relay switch

YES – Loose or poor contact starter relay switch connector

The starter motor turns when the transmission is in neutral, but does not turn with the transmission in any position except neutral, with the sidestand up and clutch lever pulled in.

1. Clutch Switch Inspection

Check the clutch switch operation.

Is the clutch switch operation normal?

NO – Faulty clutch switch

YES – GO TO STEP 2.

2. Sidestand Switch Inspection

Check the sidestand switch operation.

Is the sidestand switch operation normal?

NO – Faulty sidestand switch (page 20-20)

YES –

- Open circuit in wire harness
- Loose or poor contact connector

Starter motor turns engine slowly

- Low battery voltage
- Poorly connected battery cables
- Poorly connected starter motor cable
- Faulty starter motor

Starter motor turns, but engine does not turn

- Starter motor is running backwards
 - Case assembled improperly
 - Terminals connected improperly
- Faulty starter clutch
- Damaged or faulty starter drive gear, driven gear, idle gear and/or reduction gear

Starter relay switch "CLICK", but engine does not turn over

- Crankshaft does not turn due to engine problems

ELECTRIC STARTER

STARTER MOTOR

REMOVAL

- With the ignition switch OFF, disconnect the battery negative (-) cable before servicing the starter motor.

Remove the thermostat housing (page 7-8).

Open the rubber cap, then remove the terminal nut and starter motor cable from the starter motor.

Remove the starter motor mounting bolts and ground cable.

Remove the starter motor from the crankcase.

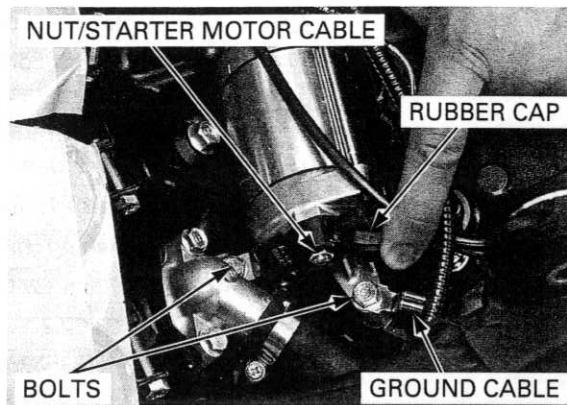

Remove the O-ring from the starter motor.

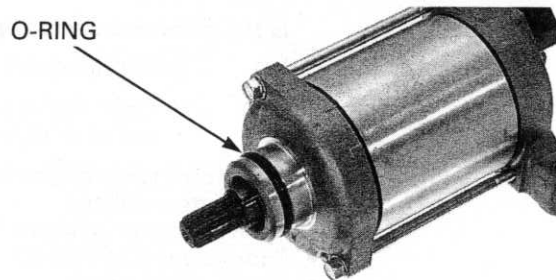

DISASSEMBLY/INSPECTION

Remove the bolts.

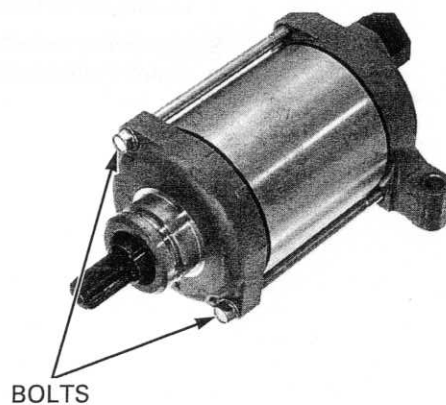

Remove the front cover and seal ring.

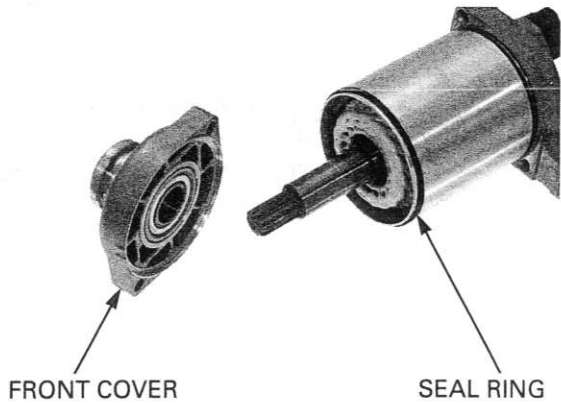

Remove the starter motor case and seal ring.
Remove the armature from the rear cover.

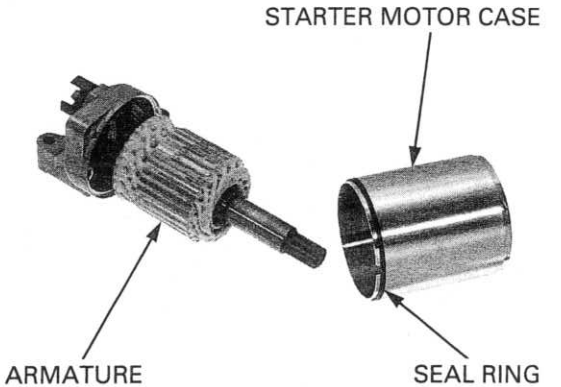

Remove the brushes and springs from the brush holder.

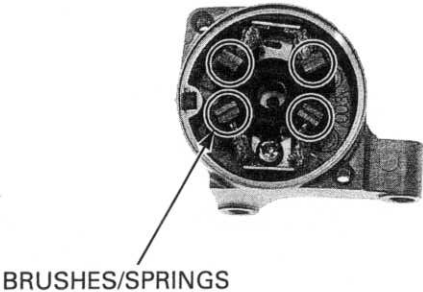

Check for continuity between starter motor cable terminal and positive brushes.
There should be continuity.

Continuity:
STARTER MOTOR CABLE TERMINAL

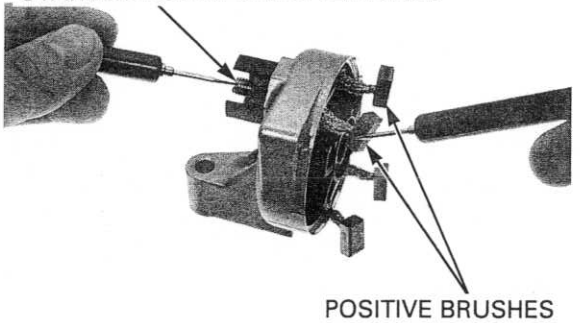

ELECTRIC STARTER

Check for continuity between positive brushes (terminal bolt side) and rear cover.

There should be no continuity.

Check for continuity between positive and negative brushes.

There should be no continuity.

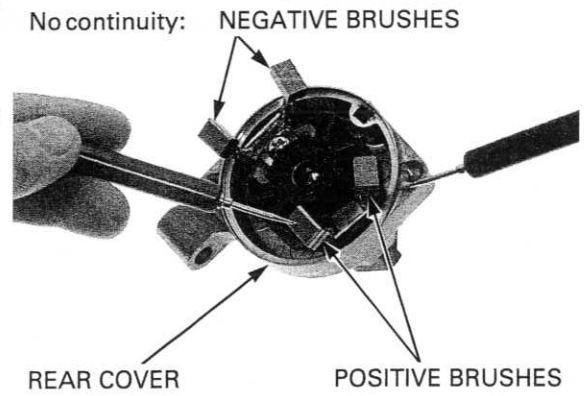

Remove the screw and negative brushes.

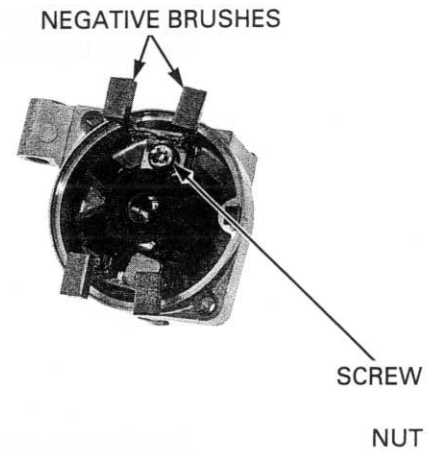

Remove the terminal nut.

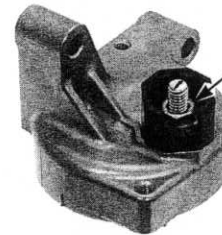

Remove the washer, insulator, terminal stopper and O-ring.

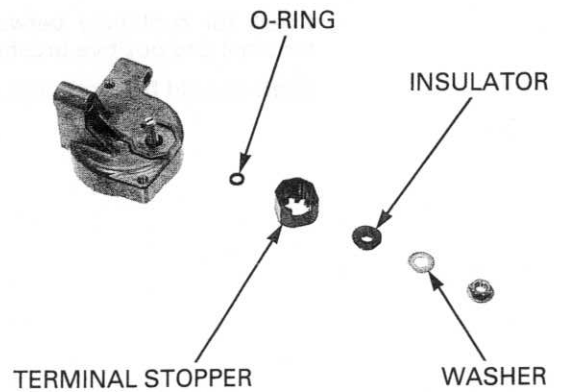

Remove the terminal bolt, positive brushes and brush holder.

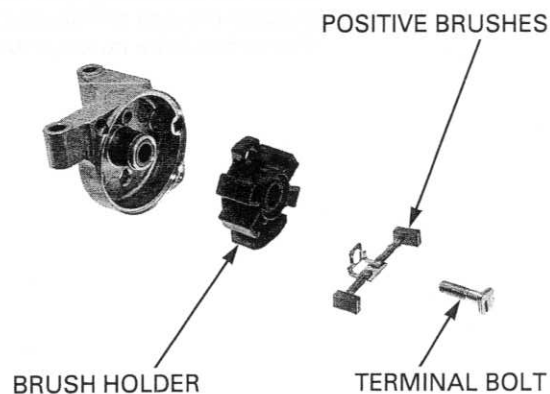

INSPECTION

Measure each brush length.

SERVICE LIMIT: 6.5 mm (0.26 in)

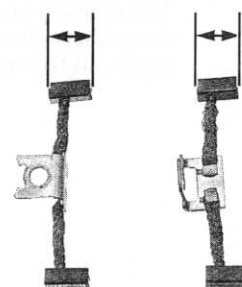

Check the commutator for damage or abnormal wear.

Do not use emery or sand paper on the commutator.

Check the commutator bar for discoloration. Clean the metallic debris off between commutator bars.

Replace the armature with a new one if necessary.

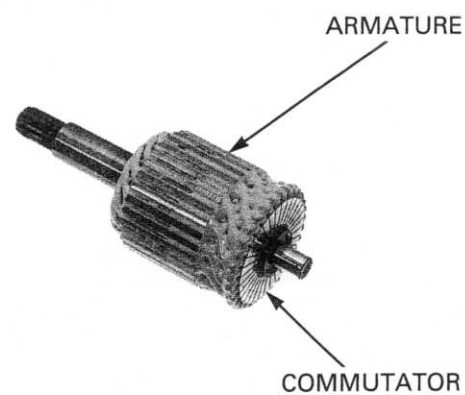

Check for continuity between pairs of commutator bars. There should be continuity.

Continuity:

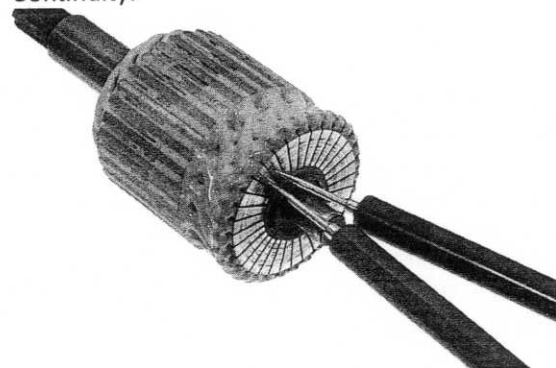

ELECTRIC STARTER

Check for continuity between each individual commutator bar and armature shaft. There should be no continuity.

No continuity:

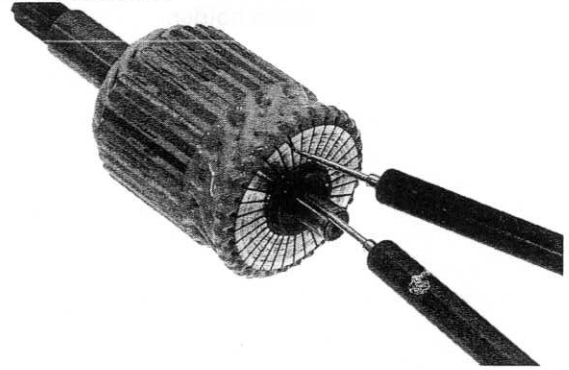

Check the dust seal for deterioration, wear or damage.

Turn the inner race of the starter motor bearing with your finger. The bearing should turn smoothly and quietly. Also check that the outer race of the bearing fits tightly in the front cover.

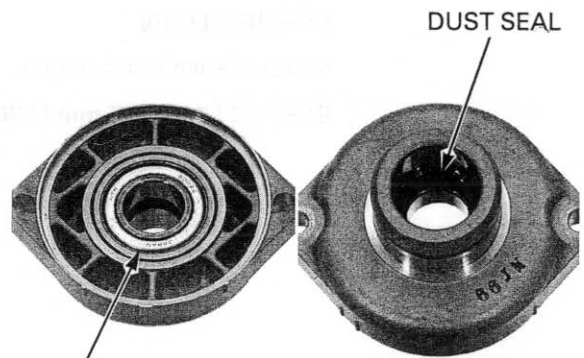

Check the bushing of the rear cover for wear or damage.

BUSHING

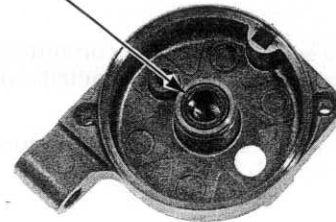

ASSEMBLY

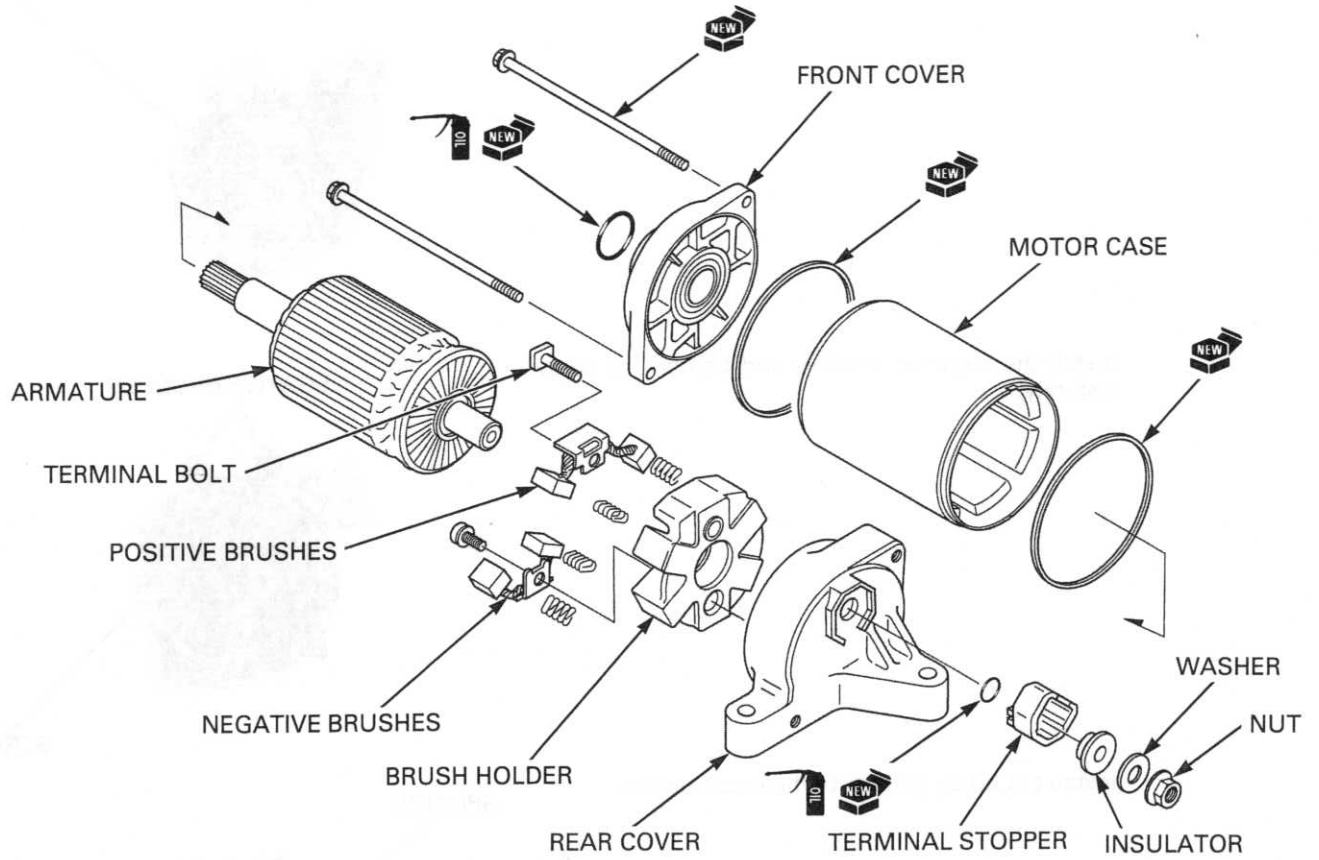

Install the brush holder, positive brushes and terminal bolt.

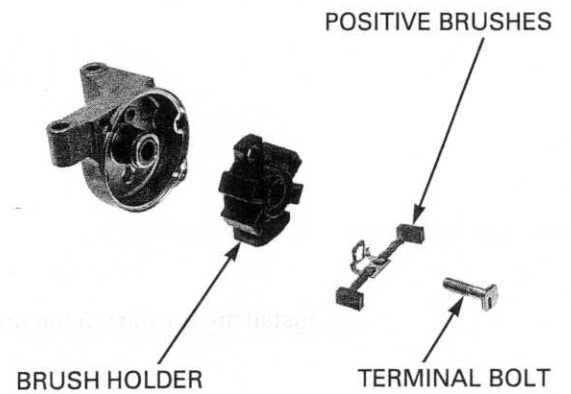

Install a new O-ring, terminal stopper, insulator and washer.

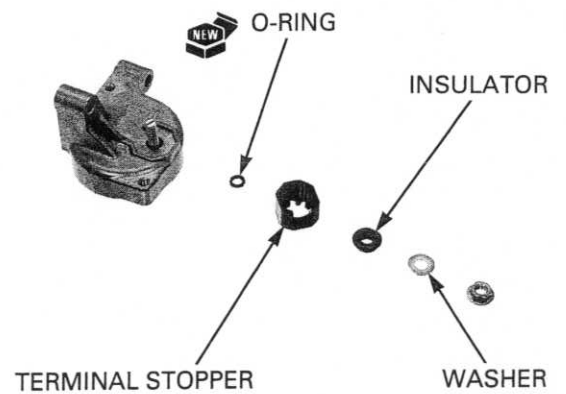

ELECTRIC STARTER

Tighten the terminal nut securely.

NUT

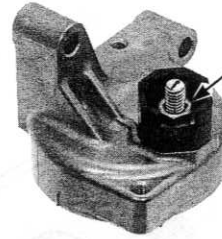

Install the negative brushes and tighten the screw securely.

NEGATIVE BRUSHES

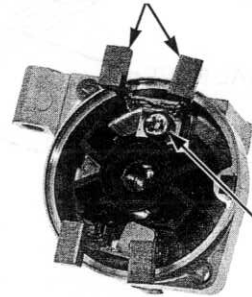

SCREW

Install the brush springs to the brush holder.

SPRINGS

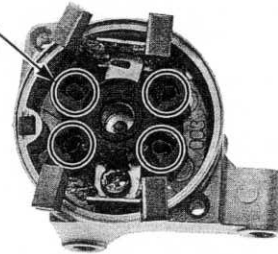

Install the brushes to the brush holder.

BRUSHES

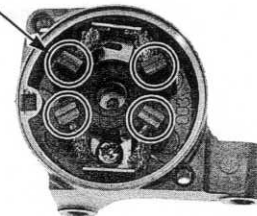

Install the armature to the rear cover.

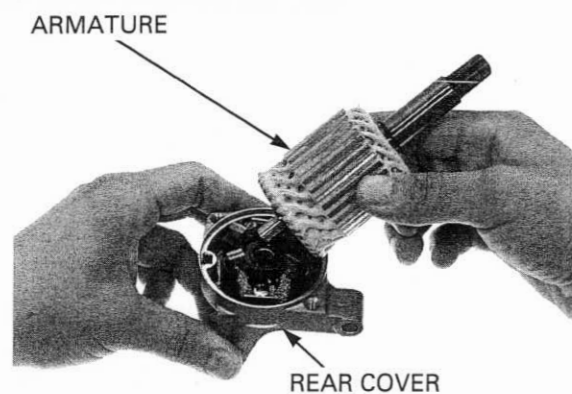

Install a new seal ring to the starter motor case. Install the starter motor case with its groove with the tab on the rear cover.

NOTICE

The coil may be damaged if the magnet pulls the armature against the case.

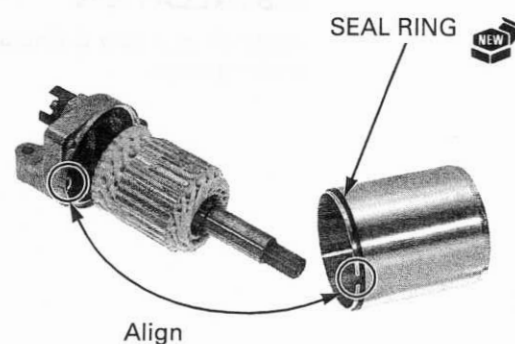

Install a new seal ring to the starter motor case. Install the front cover to the starter motor case.

NOTE:

When installing the front cover, take care to prevent damaging the oil seal lip with the armature shaft.

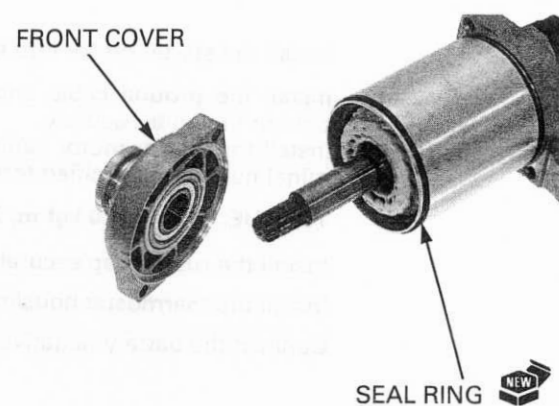

Align the index marks on the front cover, starter motor case and rear cover.

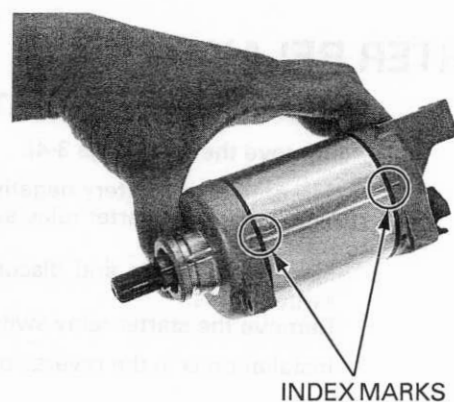

ELECTRIC STARTER

Install new bolts and tighten them securely.

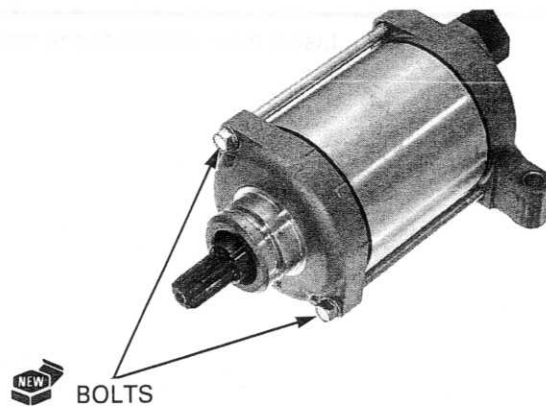

INSTALLATION

Apply oil to a new O-ring and install it to the starter motor groove.

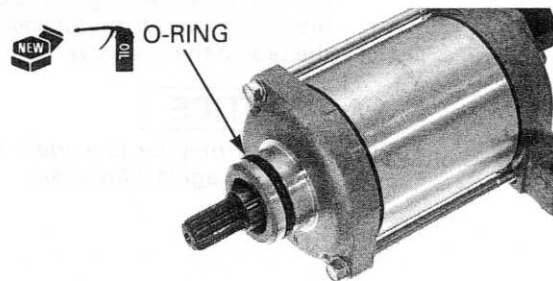

Install the starter motor into the crankcase.

Route the wires properly (page 1-21).

Install the ground cable and mounting bolts, and tighten the bolts securely. Install the starter motor cable, then tighten the terminal nut to the specified torque.

TORQUE: 10 N·m (1.0 kgf·m, 7 lbf·ft)

Install the rubber cap securely.

Install the thermostat housing (page 7-10).

Connect the battery negative (-) cable (page 17-6).

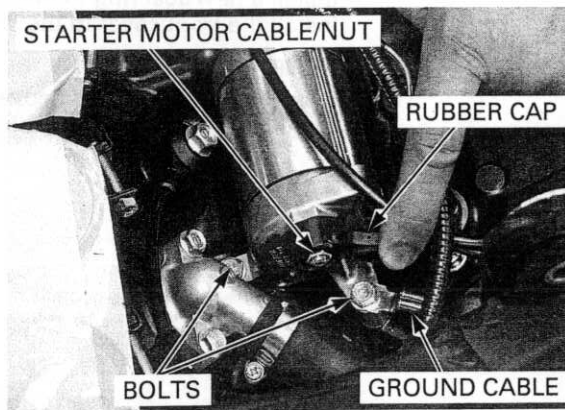

STARTER RELAY SWITCH

REMOVAL/INSTALLATION

Remove the seat (page 3-4).

Disconnect the battery negative (-) cable. Disconnect the starter relay switch 4P (Red) connector.

Remove the bolts and disconnect the starter relay switch wires.

Remove the starter relay switch.

Installation is in the reverse order of removal.

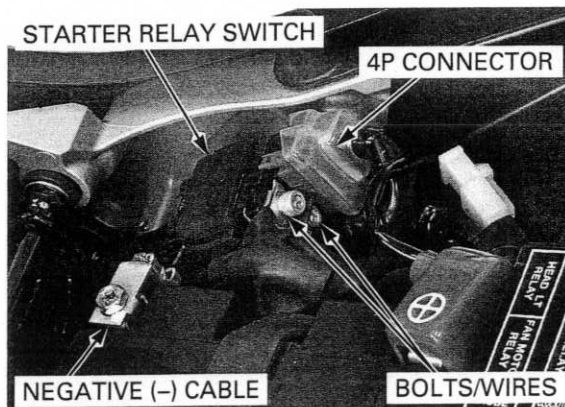

OPERATION INSPECTION

Remove the seat (page 3-4).

Shift the transmission into neutral.

Turn the ignition switch ON and press the starter switch button.

The coil is normal if the starter relay switch clicks.

If you don't hear the switch "CLICK", inspect the relay switch using the procedure below.

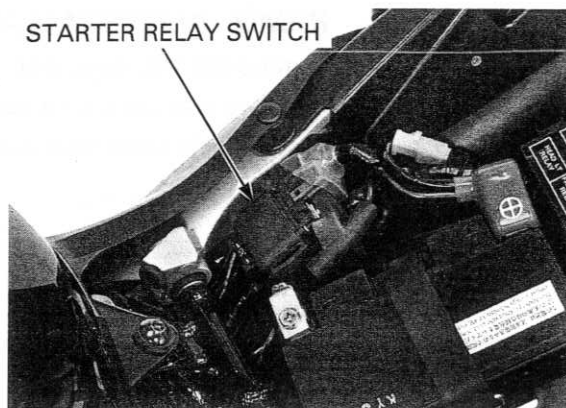

GROUND LINE INSPECTION

Disconnect the starter relay switch 4P (Red) connector.

Check for continuity between the Green/red wire (ground line) and ground.

If there is continuity when the transmission is in neutral and clutch lever released or when the clutch lever pulled and the sidestand up, the ground circuit is normal (In neutral, there is a slight resistance due to the diode).

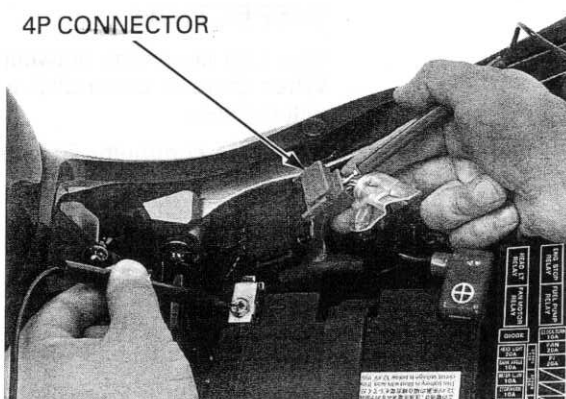

INPUT VOLTAGE INSPECTION

Connect the starter relay switch 4P (Red) connector.

Shift the transmission into neutral.

Measure the voltage between the Yellow/red wire terminal (+) and ground (-).

If the battery voltage appears when the starter switch button is pushed with the ignition switch ON, it is normal.

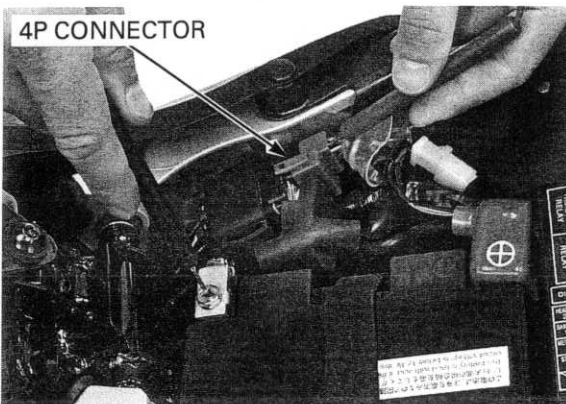

CONTINUITY INSPECTION

Remove the starter relay switch (page 19-14).

Connect an ohmmeter to the starter relay switch large terminals.

Connect a fully charged 12 V battery positive (+) wire to the starter relay switch Yellow/red terminal and negative (-) wire to the Green/red terminal.

There should be continuity between the large terminals while the battery is connected, and no continuity when the battery is disconnected.

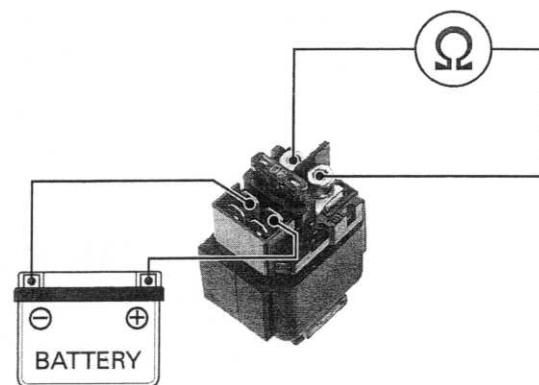

ELECTRIC STARTER

DIODE

REMOVAL/INSTALLATION

Remove the seat (page 3-4).

Open the fuse box and remove the diode.

Installation is in the reverse order of removal.



INSPECTION

Check for continuity between the diode terminals. When there is continuity, a small resistance value will register.

If there is continuity, in one direction, the diode is normal.

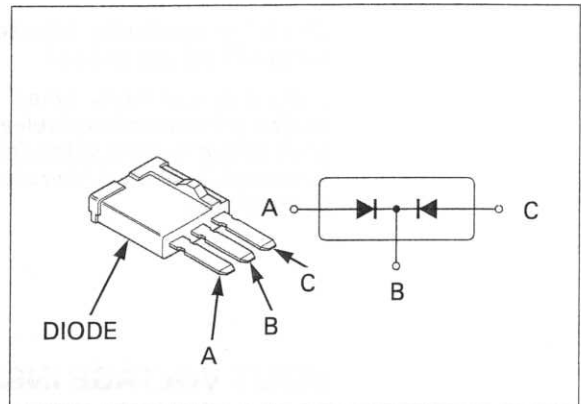

20. LIGHTS/METERS/SWITCHES

SYSTEM LOCATION.....	20-2	FUEL LEVEL SENSOR.....	20-16
SERVICE INFORMATION	20-3	IGNITION SWITCH	20-17
TROUBLESHOOTING	20-5	HANDLEBAR SWITCHES.....	20-17
HEADLIGHT.....	20-6	BRAKE LIGHT SWITCH	20-19
TURN SIGNAL LIGHT.....	20-7	CLUTCH SWITCH	20-19
BRAKE/TAIL/LICENSE LIGHT.....	20-7	NEUTRAL SWITCH.....	20-20
COMBINATION METER.....	20-7	SIDESTAND SWITCH.....	20-20
SPEEDOMETER/VS SENSOR.....	20-11	HORN	20-23
TACHOMETER	20-12	TURN SIGNAL RELAY	20-23
ECT SENSOR	20-14	HEADLIGHT RELAY.....	20-24
EOP SWITCH.....	20-14		

SYSTEM LOCATION

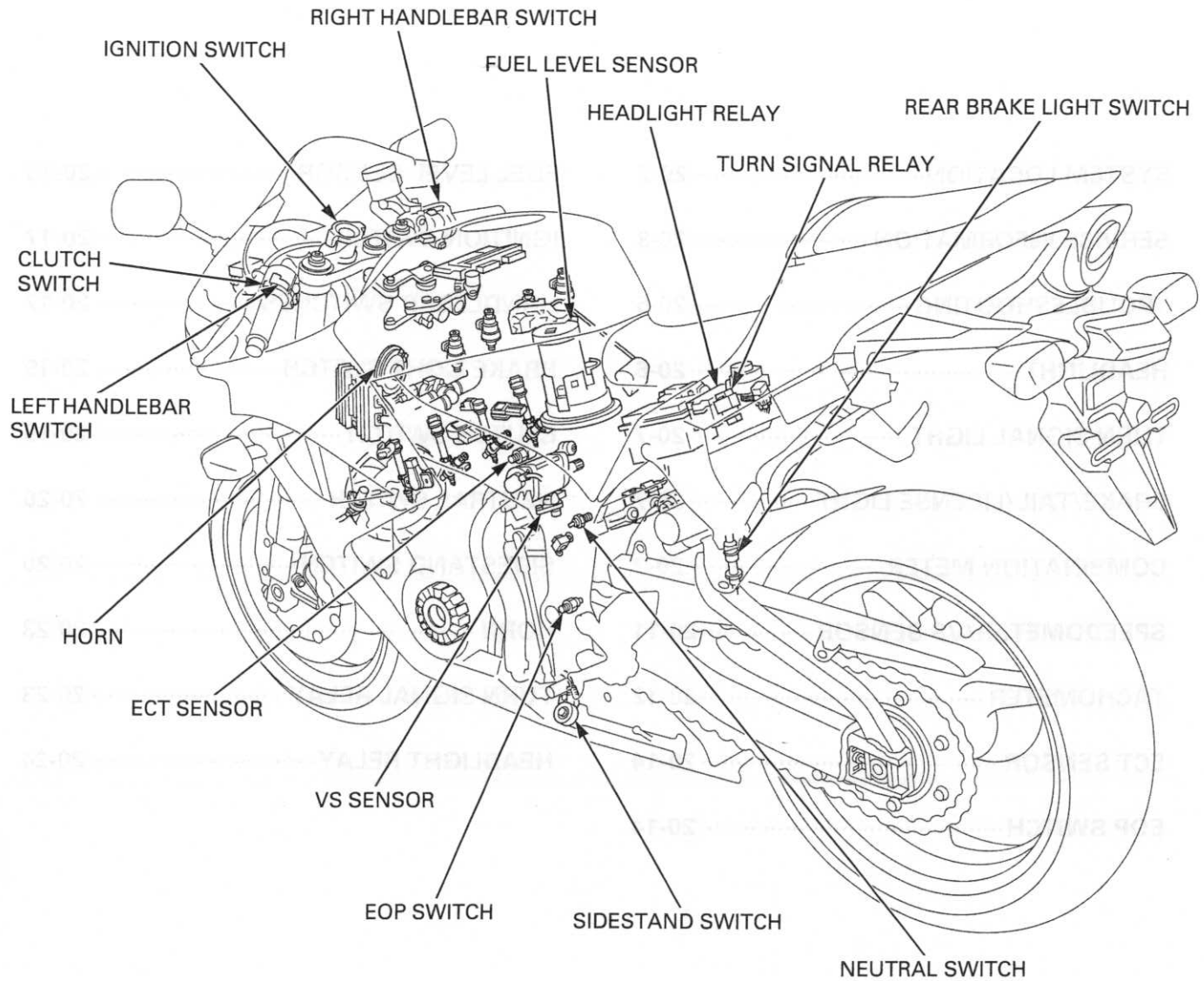

SERVICE INFORMATION

GENERAL

NOTICE

- A halogen headlight bulb becomes very hot while the headlight is on, and remains hot for a while after it is turned off. Be sure to let it cool down before servicing.
- Note the following when replacing the halogen headlight bulb.
 - Wear clean gloves while replacing the bulb. Do not put finger prints on the headlight bulb, as they may create hot spots on the bulb and cause it to fail.
 - If you touch the bulb with your bare hands, clean it with a cloth moistened with denatured alcohol to prevent its early failure.
- Use an electric heating element to heat the water/coolant mixture for the ECT sensor inspection. Keep flammable materials away from the electric heating element. Wear protective clothing, insulated gloves and eye protection.
- Check the battery condition before performing any inspection that requires proper battery voltage.
- A continuity test can be made with the switches installed on the motorcycle.
- Position light removal/installation (page 3-11).
- The following color codes are used throughout this section.

Bu = Blue	G = Green	Lg = Light Green	R = Red
Bl = Black	Gr = Gray	O = Orange	W = White
Br = Brown	Lb = Light Blue	P = Pink	Y = Yellow

SPECIFICATIONS

ITEM		SPECIFICATIONS	
Bulbs	Headlight	Hi	12 V – 55 W
		Lo	12 V – 55 W
	Position light	LED	
	Brake/tail/license light	LED	
	Front turn signal/position light	12 V – 23/8 W x 2	
	Rear turn signal light	12 V – 21 W x 2	
	Instrument light	LED	
	Turn signal indicator	LED	
	High beam indicator	LED	
	Neutral indicator	LED	
	MIL	LED	
	HESD indicator	LED	
	Engine oil pressure indicator	LED	
	Engine coolant temperature indicator	LED	
Fuse	Main fuse	30 A	
	Sub fuse	10 A x 4, 20 A x 3	
Tachometer peak voltage		10.5 V minimum	
ECT sensor resistance	80°C (176°F)	2.1 – 2.6 kΩ	
	120°C (248°F)	0.6 – 0.7 kΩ	

TORQUE VALUES

Ignition switch mounting bolt	24 N·m (2.4 kgf·m, 18 lbf·ft)	Replace with a new one
EOP switch	12 N·m (1.2 kgf·m, 9 lbf·ft)	Apply sealant to the threads
EOP switch wire terminal screw	2.0 N·m (0.2 kgf·m, 1.5 lbf·ft)	
Neutral switch	12 N·m (1.2 kgf·m, 9 lbf·ft)	
Combination meter screw	1.0 N·m (0.1 kgf·m, 0.7 lbf·ft)	
Sidestand switch mounting bolt	10 N·m (1.0 kgf·m, 7 lbf·ft)	ALOC bolt; replace with a new one
Mirror stay mounting bolt	12 N·m (1.2 kgf·m, 9 lbf·ft)	ALOC bolt; replace with a new one

LIGHTS/METERS/SWITCHES

TOOLS

Peak voltage adaptor
07HGJ-0020100

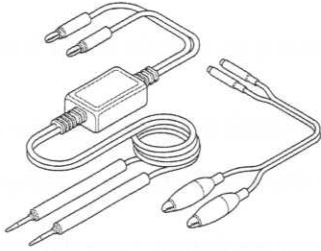

Not available in U.S.A.
with commercially available digital
multimeter (impedance 10 M Ω /DCV
minimum)

Test probe
07ZAJ-RDJA110

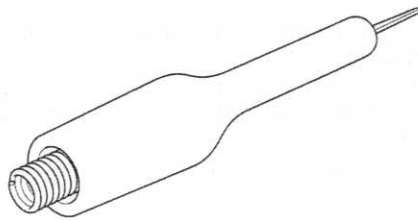

IgnitionMate peak voltage tester
MTP07-0286 (U.S.A. only)

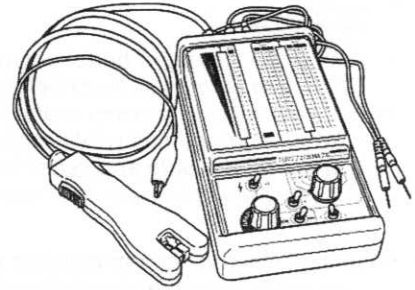

TROUBLESHOOTING

VS SENSOR/SPEEDOMETER

The speedometer and odometer/trip meter indicates "----".

Faulty EEPROM in ECM

The odometer/trip meter operate normally, but the speedometer does not operate

Faulty speedometer in combination meter

The speedometer operates normally, but the odometer/trip meter does not operate

Faulty odometer/trip meter in combination meter

The speedometer operates abnormally

1. Fuse Inspection

Check for blown main fuse or sub fuse (CLOCK/TURN 10 A).

Is the fuse blown?

YES – Replace the fuse

NO – GO TO STEP 2.

2. Battery Inspection

Make sure the battery is fully charged and in good condition.

Is the battery in good condition?

YES – GO TO STEP 3.

NO – Replace the battery

3. VS Sensor Power Input Voltage Inspection (VS Sensor Side)

Disconnect the VS sensor 3P (Black) connector and measure the voltage at the VS sensor connector Violet terminal with the ignition switch ON.

Is there Battery Voltage?

NO – • Loose or poor contact of related terminals
• Open circuit in Violet wires between the combination meter and VS sensor

YES – GO TO STEP 4.

4. VS Sensor Power Input Voltage Inspection (Combination Meter Side)

Connect the VS sensor 3P (Black) connector and check for loose or poor contact of the combination meter 20P (Black) connector.

With the ignition switch ON, and measure the voltage at bottom of the combination meter 20P (Black) connector Violet terminal.

Is the Voltage more than 10 V (20°C/68°F)?

NO – • Loose or poor contact of related terminals
• Faulty combination meter

YES – GO TO STEP 5.

5. VS Sensor Signal Line Inspection

With the ignition switch OFF, check for continuity of the Pink/green wire between the terminals of the VS sensor and speedometer.

Is there continuity?

NO – Open circuit in Pink/green wire

YES – GO TO STEP 6.

6. VS Sensor Signal Inspection

Support the motorcycle using a hoist or other support to raise the rear wheel off the ground.

Measure the output voltage (sensor signal) at the speedometer with the ignition switch ON while slowly turning the rear wheel with your hand (page 20-11).

Standard: Repeat 0 to 5 V

Is the voltage as specified?

NO – Faulty VS sensor

YES – Faulty speedometer

HEADLIGHT

BULB REPLACEMENT

Remove the dust cover.
Disconnect the headlight bulb connector.
Unhook the bulb retainer and remove the headlight bulb.

NOTICE

Avoid touching the halogen headlight bulb. Finger prints can create hot spots that cause a bulb to break.

Install a new headlight bulb aligning its tab with the groove in the headlight unit.

If you touch the bulb with your bare hands, clean it with a cloth moistened with denatured alcohol to prevent early bulb failure.

Hook the bulb retainer securely.

Connect the headlight bulb connector.

Install the removed parts in the reverse order of removal.

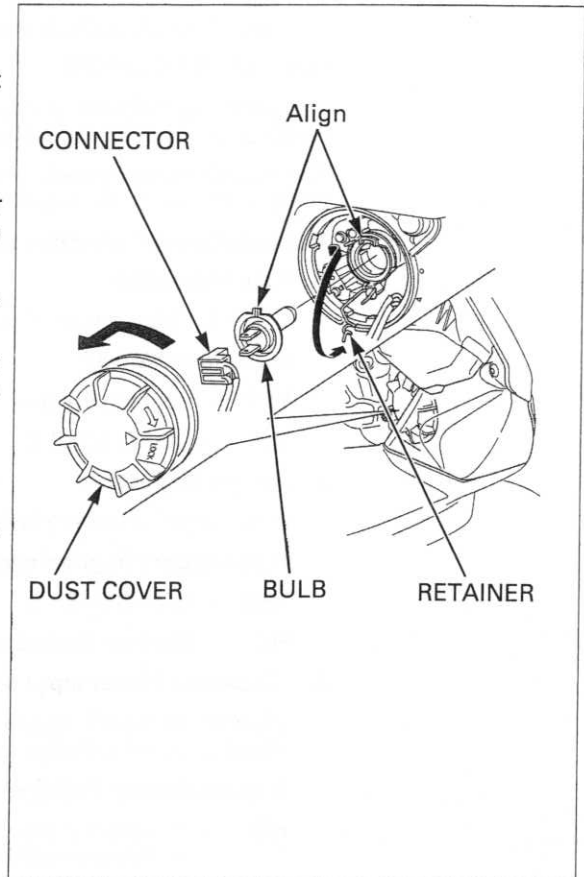

REMOVAL/INSTALLATION

Remove the upper cowl/front spoiler (page 3-11).
Disconnect the headlight 2P (Natural) connector.

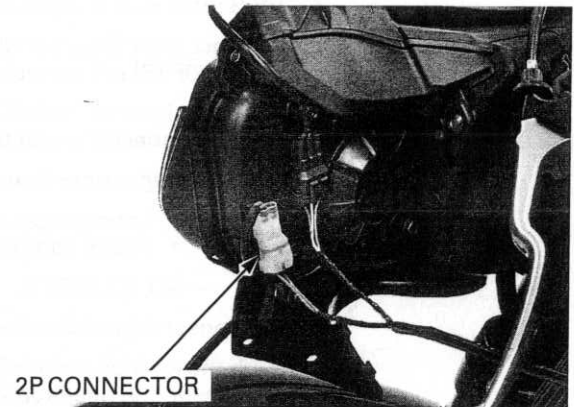

Remove the collar, screw and headlight unit.
Installation is in the reverse order of removal.

Rout the wire harness properly (page 1-21).

TORQUE:

**Headlight mounting screw:
1.8 N·m (0.2 kgf·m, 1.3 lbf·ft)**

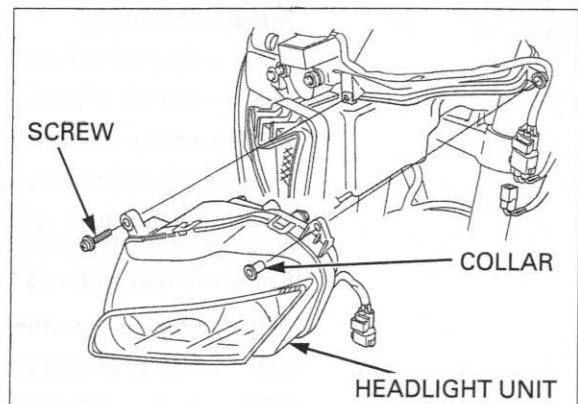

TURN SIGNAL LIGHT

BULB REPLACEMENT

Remove the screw, turn signal lens and rubber seal.

While pushing in, turn the bulb counterclockwise to remove it and replace with a new one.

Install the rubber seal, lens and tighten the screw securely.

- For front turn signal light removal/installation (page 3-8).
- For rear turn signal light removal/installation (page 3-13).

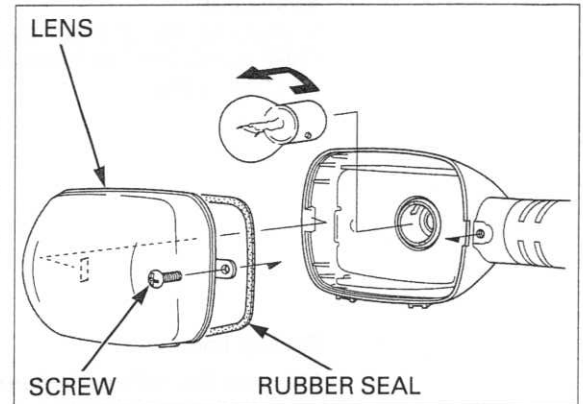

BRAKE/TAIL/LICENSE LIGHT

INSPECTION

Turn the ignition switch ON, and check the tail light operation.

Check that all LED in the brake/tail/license light unit illuminate with the front brake lever and/or rear brake pedal applied.

If any LED does not turn on, replace the brake/tail/license light assembly (page 3-13).

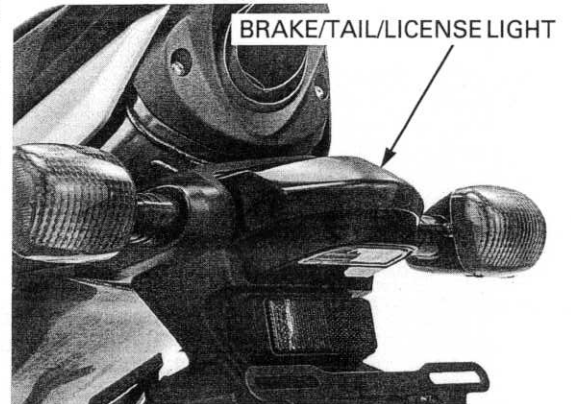

COMBINATION METER

POWER/GROUND LINES INSPECTION

Remove the windscreen (page 3-10).

Check the following at the wire side connector terminals of the combination meter with the 20P (Black) connector connected.

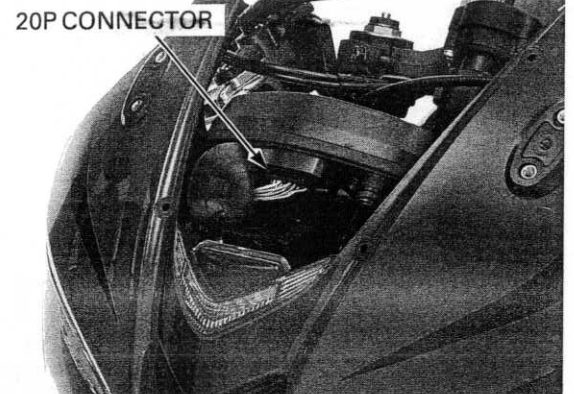

LIGHTS/METERS/SWITCHES

Power input line

Measure the voltage between the White/black wire terminal (+) and ground (-). There should be battery voltage with the ignition switch ON. If there is no voltage, check the METER ILLUMI (10A) and White/black wire for a loose connection or an open circuit.

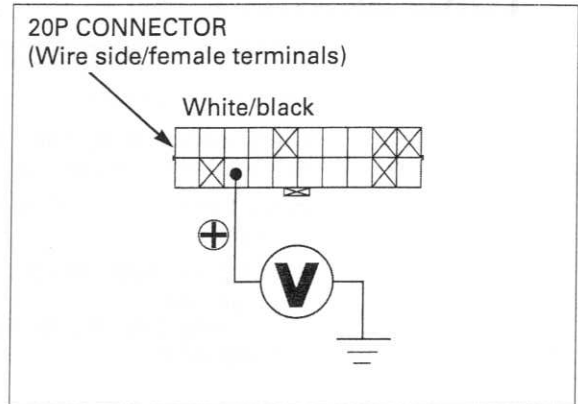

Backup line

Measure the voltage between the White/green wire terminal (+) and ground (-). There should be battery voltage. If there is no voltage, check the CLOCK/TURN (10A) and White/green wire for a loose connection or an open circuit.

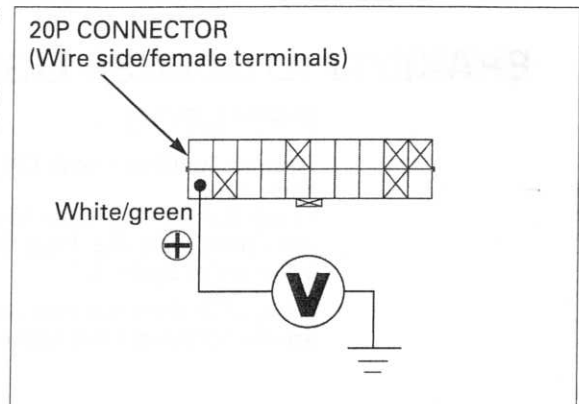

Ground line

Measure the continuity between the Green/black wire terminal and body ground. There should be continuity. If there is no continuity, check for open circuit in Green/black wire.

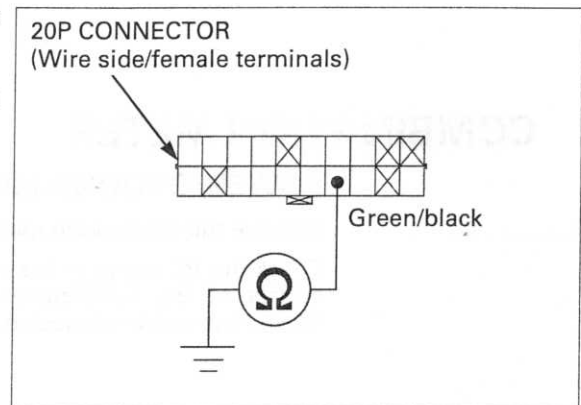

REMOVAL

Remove the following:

- Upper cowl (page 3-11)
- Front spoiler (page 3-11)
- Headlights (page 20-6)
- Bank angle sensor (page 6-73)

Remove the mirror stay mounting bolts.

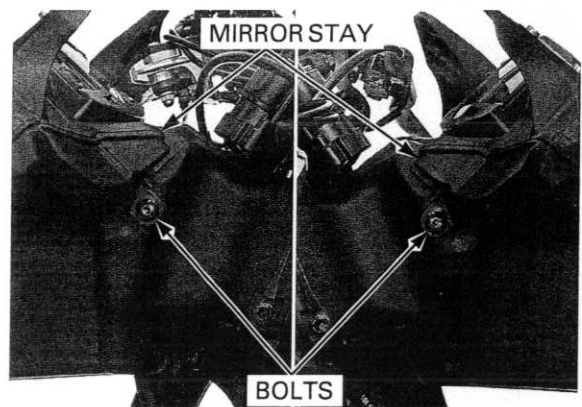

LIGHTS/METERS/SWITCHES

Disconnect the combination meter 20P (Black) connector.

Remove the bolts and mirror stay assembly.

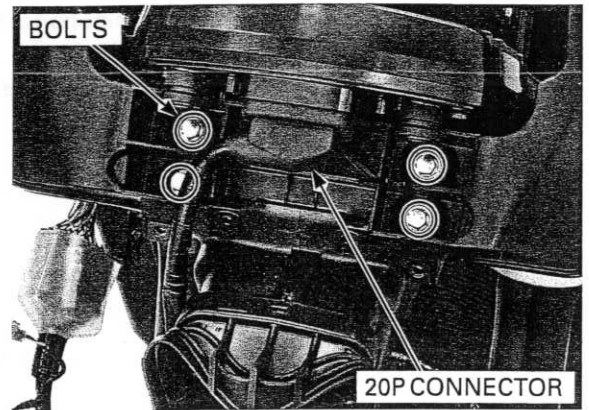

Remove the screws, washers and combination meter from the mirror stay.

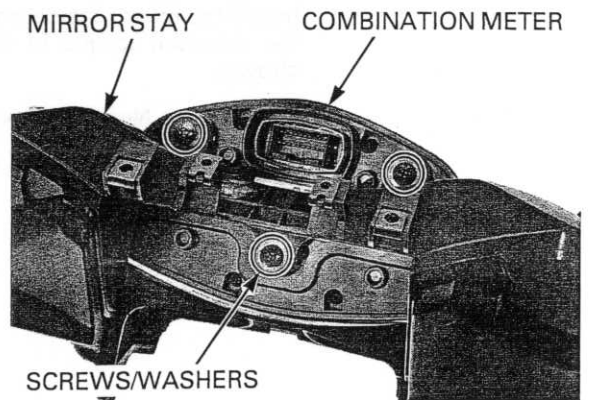

DISASSEMBLY/ASSEMBLY

Remove the screws and separate the front cover from the rear cover.

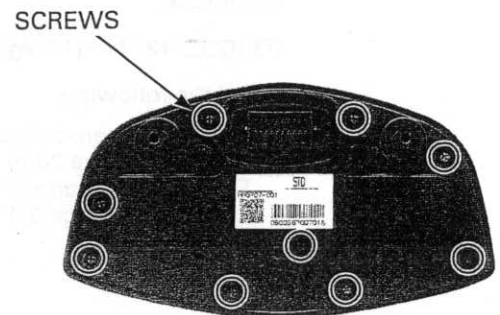

Assemble the combination meter in the reverse order of removal.

TORQUE:

Combination meter screw:
1.0 N·m (0.1 kgf·m, 0.7 lbf·ft)

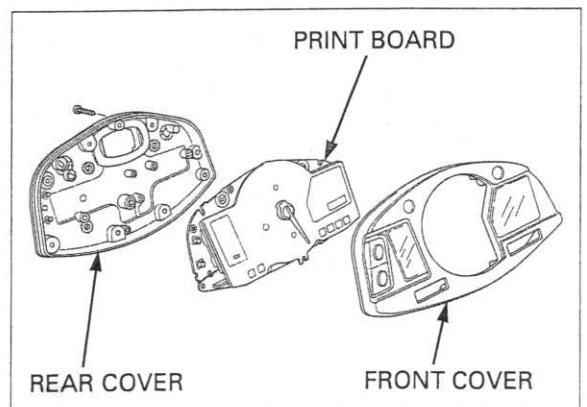

LIGHTS/METERS/SWITCHES

INSTALLATION

Install the combination meter, washers and screws to the mirror stay.

Tighten the screws securely.

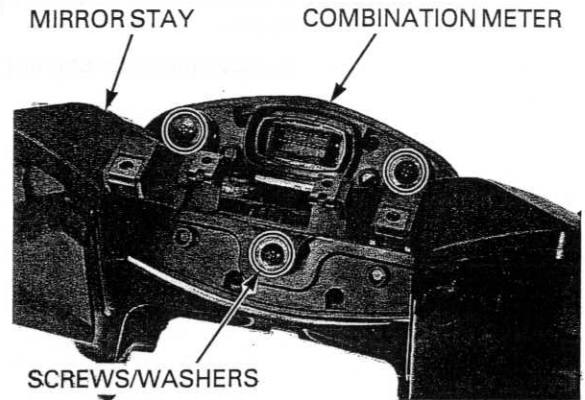

Install the mirror stay assembly and tighten bolts to the specified torque in the specified sequence as shown.

TORQUE: 12 N·m (1.2 kgf·m, 9 lbf·ft)

Connect the combination meter 20P (Black) connector.

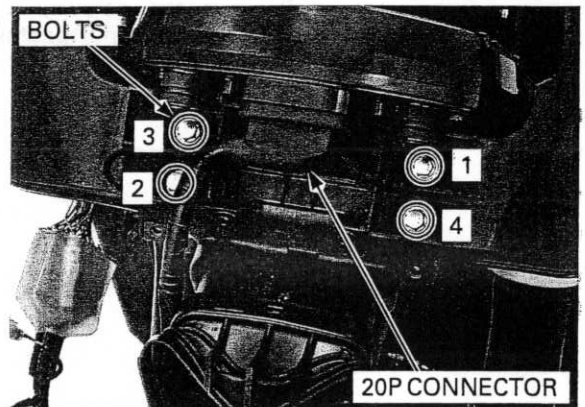

Tighten the mirror stay mounting bolts to the specified torque.

TORQUE: 12 N·m (1.2 kgf·m, 9 lbf·ft)

Install the following:

- Bank angle sensor (page 6-73)
- Headlight (page 20-6)
- Front spoiler (page 3-11)
- Upper cowl (page 3-11)



SPEEDOMETER/VS SENSOR

SYSTEM INSPECTION

Check that the tachometer and coolant temperature meter function properly.

- Check for loose or poor contact terminals at the combination meter 20P (Black) and sub harness 20P (Gray) connectors.
 - If they do not function, perform the power and ground line inspection of the combination meter (page 20-7).
 - If they function, shift the transmission into neutral and turn the ignition switch ON. Measure the voltage between the Pink/green (+) and body ground (-). Slowly turn the rear wheel by hand. There should be 0 to 5 V pulse voltage.
- If pulse voltage appears, replace the combination meter print circuit board.
 - If pulse voltage does not appear, check for open or short circuit in Pink/green wire. If the Pink/green wire is OK, check the VS sensor (page 20-11).

20P CONNECTOR



VS SENSOR INSPECTION

Lift and support the fuel tank (page 4-5).

Disconnect the VS sensor 3P (Black) connector and check for loose or poor contact of the connector.

Turn the ignition switch ON and measure the voltage at the 3P (Black) connector at the wire harness side.

Connection: Violet (+) – Green/black (-)
Standard: Battery voltage

If there is no voltage, check the following:

- Violet wire open circuit
- Green/black wire open circuit
- Combination meter (page 20-7)

REMOVAL/INSTALLATION

Lift and support the fuel tank (page 4-5).

Disconnect the VS sensor 3P (Black) connector.

Remove the bolt, VS sensor and O-ring.

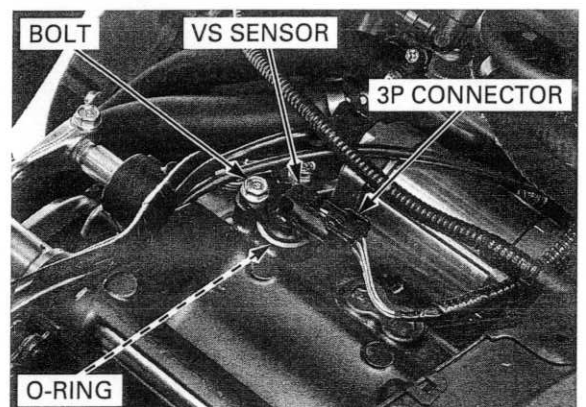
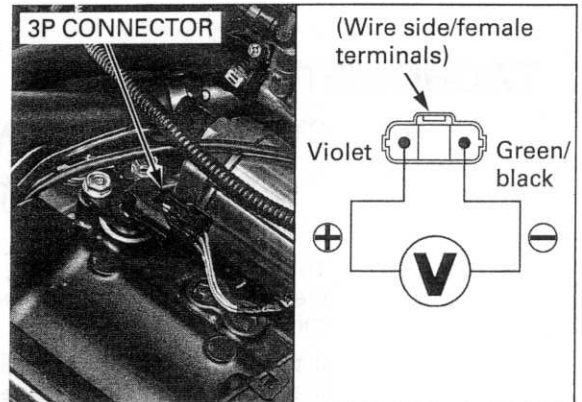

LIGHTS/METERS/SWITCHES

Apply oil to the O-ring and install it to the VS sensor.
Install the VS sensor into the upper crankcase.

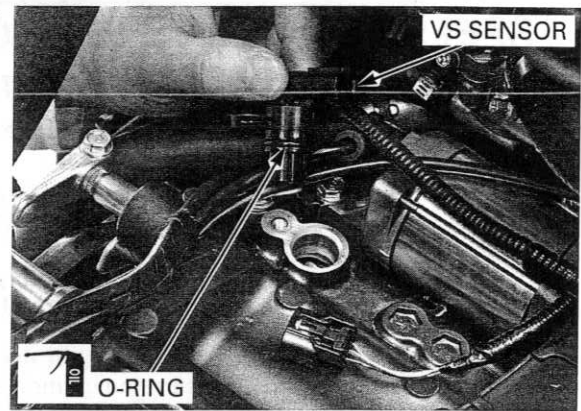

Tighten the VS sensor mounting bolt securely and connect the VS sensor 3P (Black) connector.

Remove the suitable support and close the fuel tank (page 4-6).

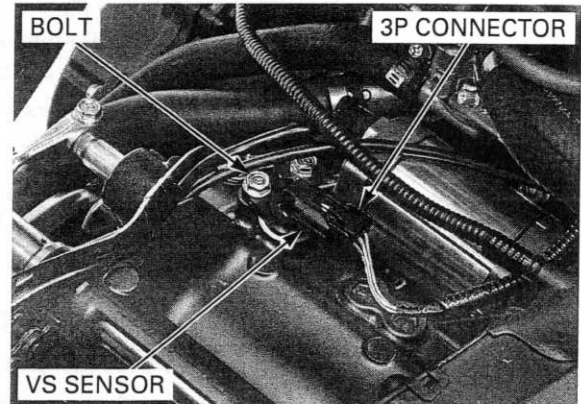

VS SENSOR

TACHOMETER

SYSTEM INSPECTION

- Check for loose or poor contact terminals at the combination meter 20P (Black) and sub harness 20P (Gray) connectors.

Turn the ignition switch ON, check that the tachometer needle moves to full scale and then returns to zero.

If the needle does not show initial function, check the combination meter power input line (page 20-7).

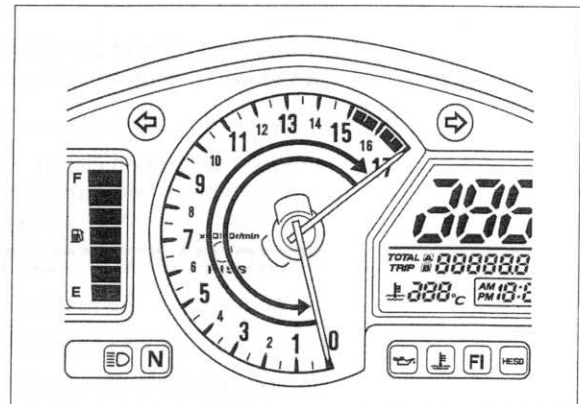

Remove the windscreen (page 3-10) and expose the combination meter 20P (Black) connector.

Connect the peak voltage adaptor to the combination meter terminal and ground.

Connection: Yellow/green (+) and Ground (-)

TOOL:

IgnitionMate peak voltage tester MTP07-0286 (U.S.A. only) or 07HGJ-0020100 (Not available in U.S.A.)

Peak voltage adaptor

with commercially available digital multimeter (impedance 10 MΩ/DCV minimum)

Start the engine and measure the tachometer input peak voltage.

PEAK VOLTAGE: 10.5 V minimum

If the peak voltage is normal, replace the combination meter assembly (page 20-8).

If the measured value is below 10.5 V, replace the ECM (page 6-74).

If the value is 0 V, check for continuity between the combination meter 20P (Black) connector and ECM 33P (Gray) connector Yellow/green terminals.

TOOL:

Test probe

07ZAJ-RDJA110

If there is no continuity, check the wire harness and combination meter sub harness for an open circuit. If there is continuity, replace the combination meter printed circuit board (page 20-8).

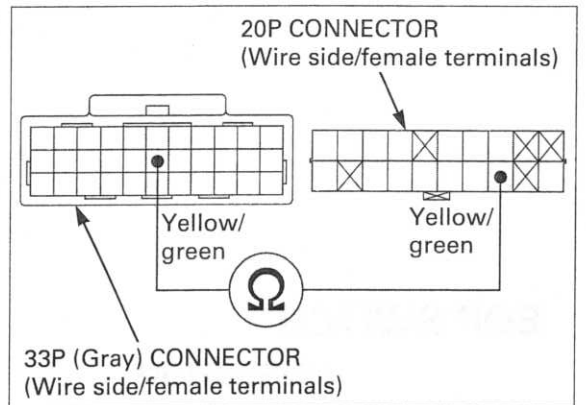
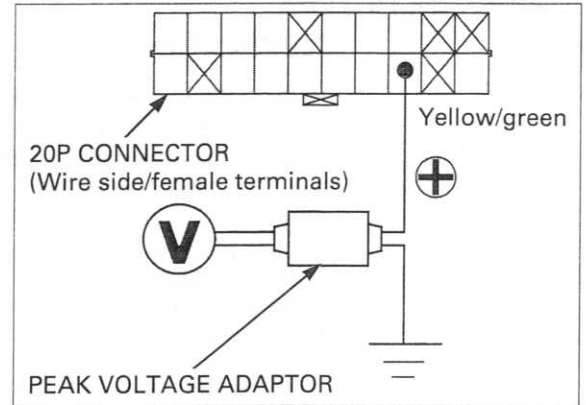

ECT SENSOR

INSPECTION

Remove the ECT sensor (page 6-71).

Suspend the ECT sensor in a pan of coolant (1:1 mixture) on an electric heating element and measure the resistance through the sensor as the coolant heats up.

- Soak the ECT sensor in coolant up to its threads with at least 40 mm (1.6 in) from the bottom of the pan to the bottom of the sensor.
- Keep the temperature constant for 3 minutes before testing. A sudden change of temperature will result in incorrect readings. Do not let the thermometer or ECT sensor touch the pan.

Replace the sensor if it is out of specification by more than 10% at any temperature listed.

Temperature	80°C (176°F)	120°C (248°F)
Resistance	2.1 – 2.6 kΩ	0.6 – 0.7 kΩ

Install the ECT sensor (page 6-71).

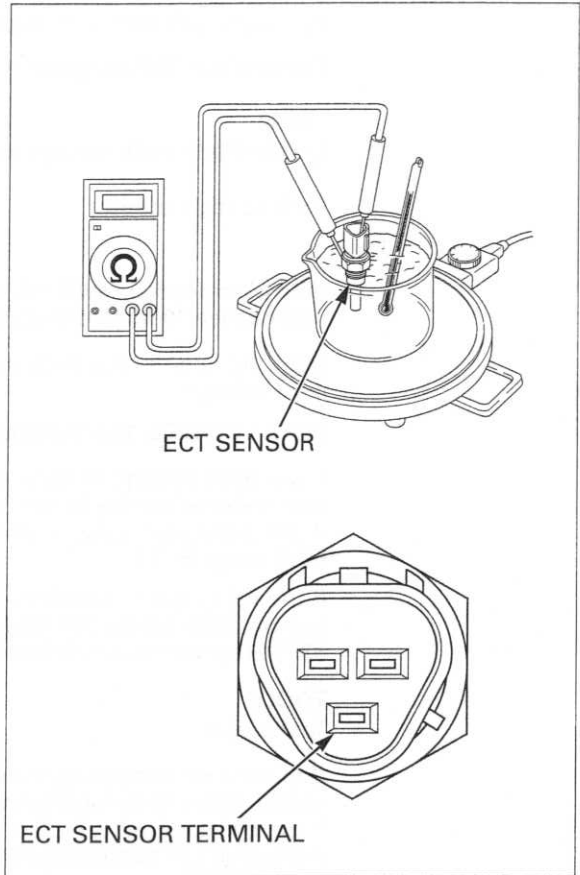

EOP SWITCH

INSPECTION

If the oil pressure warning indicator stays on while the engine is running, check the engine oil level before this inspection.

Make sure that the oil pressure warning indicator comes on with the ignition switch ON.

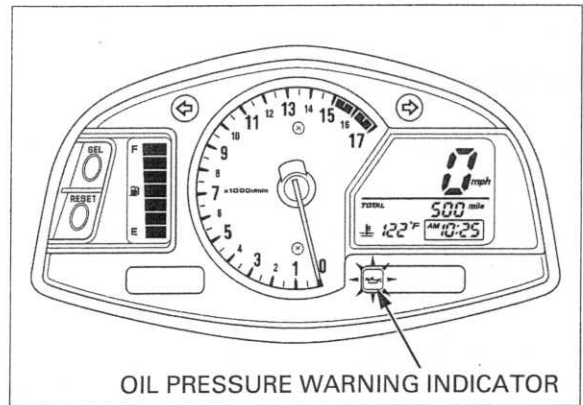

If the indicator does not come on, inspect as follows:

Remove the lower cowl (page 3-6).

Remove the dust cover, terminal screw and wire.

Short the EOP switch wire to ground.

The engine oil pressure indicator comes on when the ignition switch is ON.

If the light does not come on, check the sub fuse (CLOCK/TURN 10 A) and wires for a loose connection or an open circuit.

Start the engine and make sure the indicator goes out.

If the indicator does not go out, check the oil pressure (page 5-5).

If the oil pressure is normal, replace the EOP switch (page 20-15).

Install the lower cowl (page 3-6).

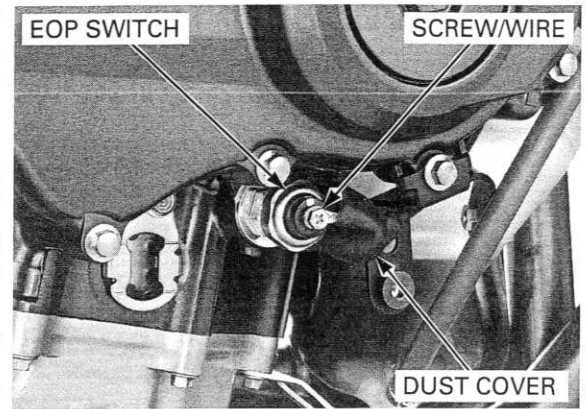

REMOVAL/INSTALLATION

If the oil pressure indicator light remains on a few seconds, check the indicator system before checking the oil pressure.

Remove the lower cowl (page 3-6).

Remove the dust cover.

Remove the bolt and disconnect the EOP switch wire.

Remove the EOP switch while holding the switch base.

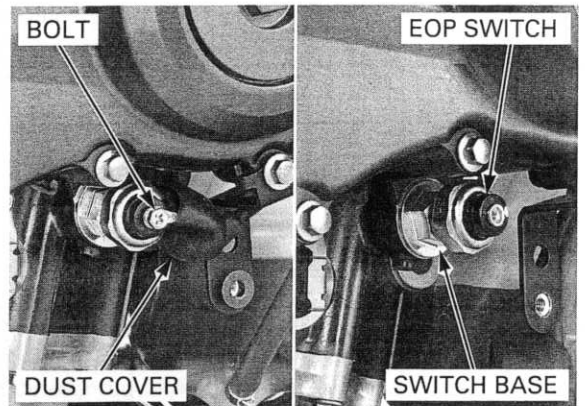

Apply sealant to the EOP switch threads.

Tighten the EOP switch to the specified torque while holding the switch base.

TORQUE: 12 N·m (1.2 kgf·m, 9 lbf·ft)

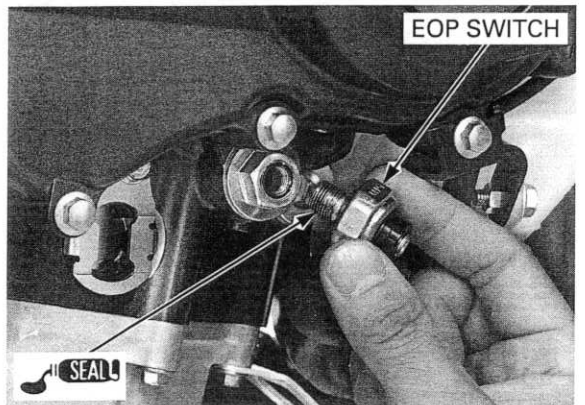

Connect the EOP switch wire terminal and tighten the bolt to the specified torque.

TORQUE: 2.0 N·m (0.2 kgf·m, 1.5 lbf·ft)

Install the dust cover.

Start the engine and check that there are no oil leaks.

Install the lower cowl (page 3-6).

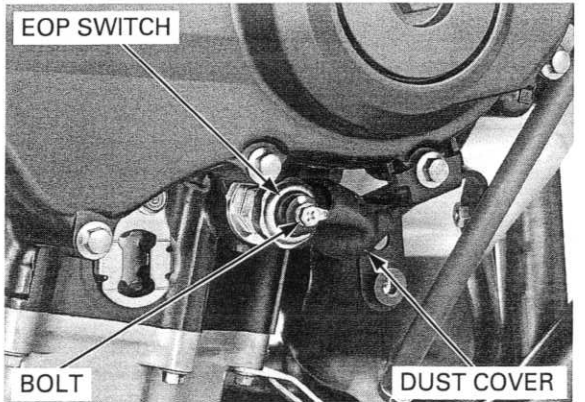

FUEL LEVEL SENSOR

If the fuel meter cycles the pattern as shown, check for an open circuit in wire harness and the fuel level sensor.

If the wire harness and fuel level sensor are good, replace the combination meter printed circuit board (page 20-8).

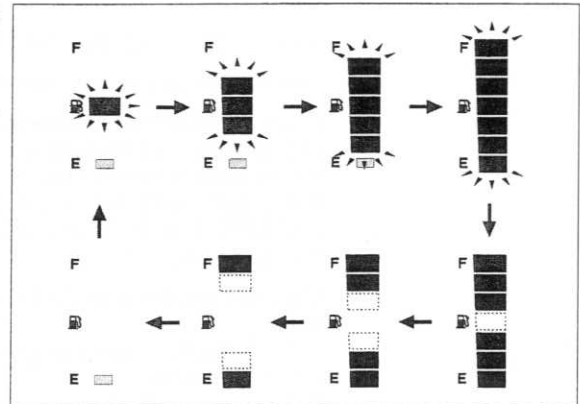

FUEL LEVEL SENSOR INSPECTION

Remove the fuel pump unit (page 6-47).

Connect an ohmmeter to the fuel pump unit 3P (Black) connector Brown/black and Green terminals. Inspect the resistance of the float at the top (full) and bottom (empty) positions.

	TOP (FULL)	BOTTOM (EMPTY)
Resistance	12 – 14 Ω	119 – 121 Ω

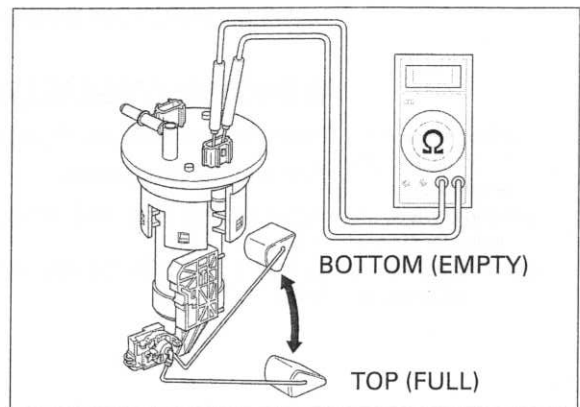

FUEL METER INSPECTION

Remove the fuel pump unit (page 6-47).
Connect the fuel pump unit 2P (Black) connector.

It takes about 1 minute for the display to reflect a change in float position.

Turn the ignition switch ON and move the float from bottom (empty) to top (full) to check the fuel meter display indication.

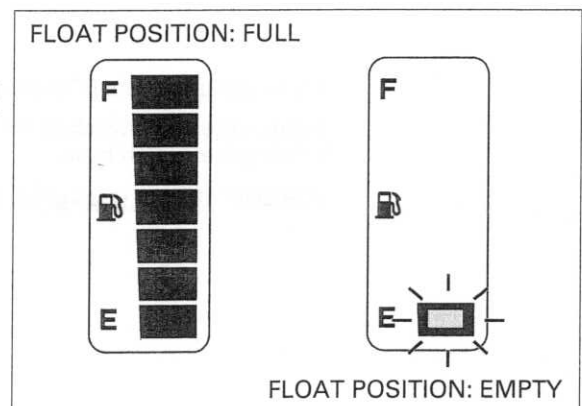

IGNITION SWITCH

INSPECTION

Remove the right middle cowl (page 3-8).
 Disconnect the ignition switch 2P (Brown) connector.

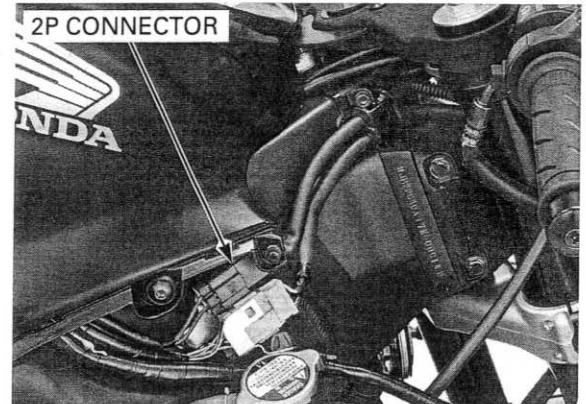

Check for continuity between the wire terminals of the ignition switch connector in each switch position. Continuity should exist between the color coded wires as follow:

IGNITION SWITCH

	BAT1	IG	KEY
ON	○	○	KEY ON
OFF			KEY OFF
LOCK			KEY OFF LOCK PIN
COLOR	R	R/B	

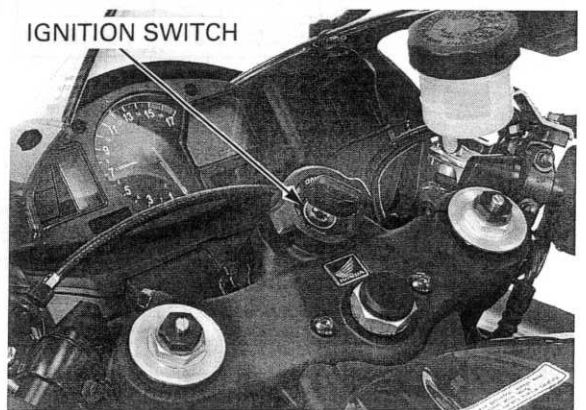

REMOVAL/INSTALLATION

Remove the top bridge (page 14-34).
 Remove the bolts and ignition switch.
 Install the ignition switch to the top bridge.
 Tighten new ignition switch mounting bolts to the specified torque.

TORQUE: 24 N·m (2.4 kgf·m, 18 lbf·ft)

Installation is in the reverse order of removal.

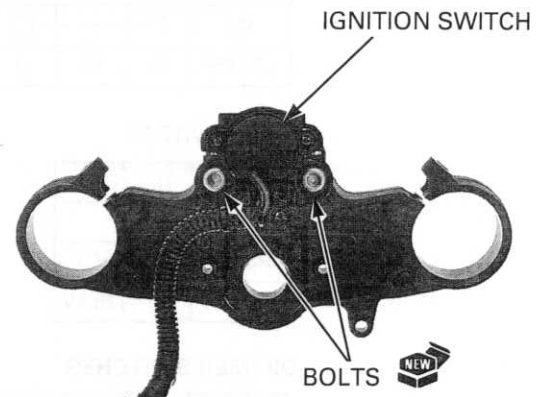

HANDLEBAR SWITCHES

Remove the middle cowls (page 3-8).
 Disconnect the handlebar switch connectors.

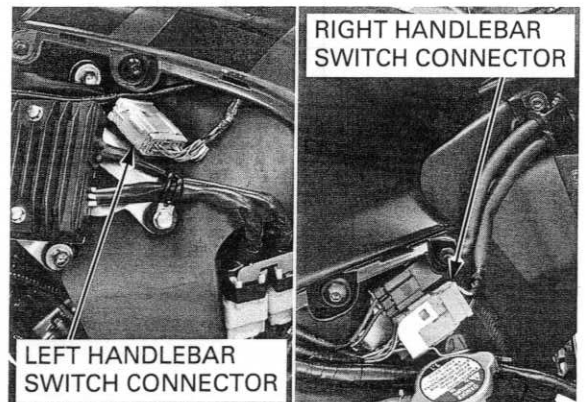

LIGHTS/METERS/SWITCHES

RIGHT SIDE

Check for continuity between the wire terminals of the handlebar switch connector.
Continuity should exist between the color coded wire terminals as follows:

ENGINE STOP SWITCH

	IG	BAT4
	○	○
COLOR	BI	W/BI

STARTER SWITCH

	BAT5	ST	H/L
FREE	○		○
PUSH	○	○	
COLOR	BI/R	Y/R	Bu/W

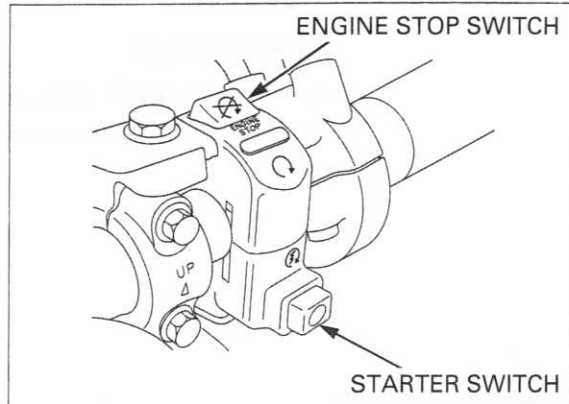

LEFT SIDE

Check for continuity between the wire terminals of the handlebar switch connector.
Continuity should exist between the color coded wire terminals as follows:

TURN SIGNAL SWITCH

	W	R	L	P	PR	PL
	○	○		○		○
N				○	○	○
	○		○	○	○	
COLOR	Gr	Lb	O	W/BI	Lb/W	O/W

HORN SWITCH

	Ho	BAT2
FREE		
PUSH	○	○
COLOR	BI	Br/W

DIMMER SWITCHES

	HL	Lo	Hi
(N)	○		○
	○		○
COLOR	Bu/W		Bu

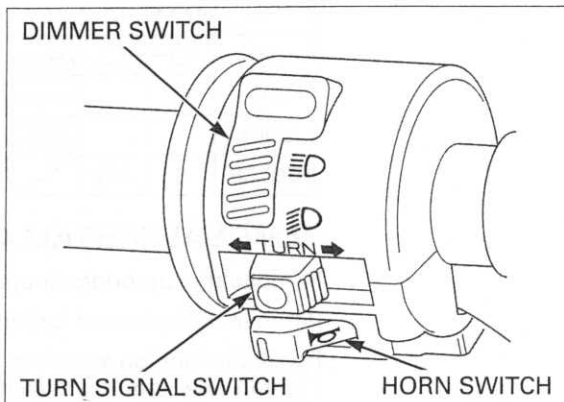

BRAKE LIGHT SWITCH

FRONT

Disconnect the front brake light switch connectors and check for continuity between the terminals.

There should be continuity with the brake lever applied, and there should be no continuity with the brake lever is released.

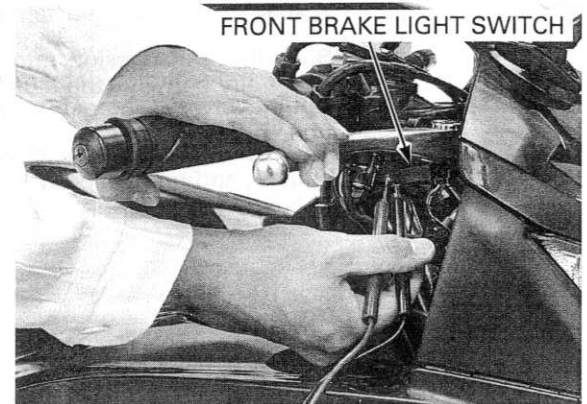

REAR

Remove the fuel tank (page 6-50).

Disconnect the rear brake light switch 2P (Black) connector.

Check for continuity between the terminals.

There should be continuity with the brake pedal applied, and there should be no continuity with the brake pedal is released.

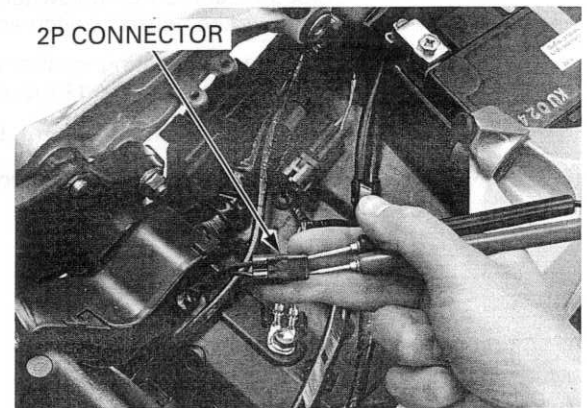

CLUTCH SWITCH

Disconnect the clutch switch connectors.

There should be continuity with the clutch lever applied, and there should be no continuity with the clutch lever is released.

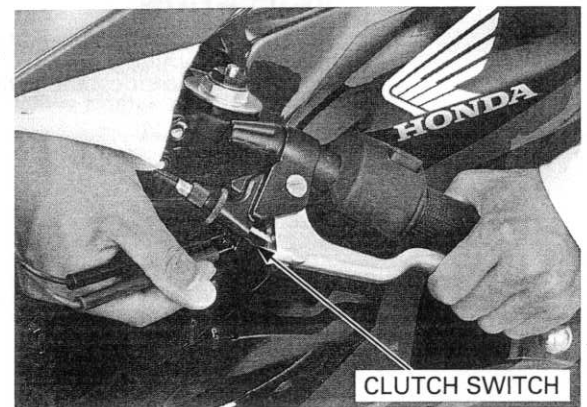

NEUTRAL SWITCH

INSPECTION

Disconnect the neutral switch connector from the switch.

Shift the transmission into neutral and check for continuity between the neutral switch terminal and ground.

There should be continuity with the transmission in neutral, and no continuity when the transmission is in gear.

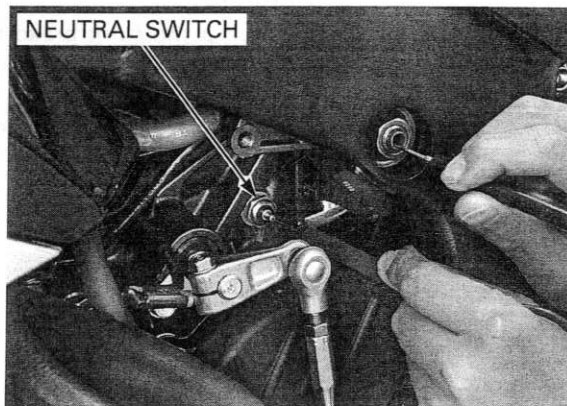

REMOVAL/INSTALLATION

Disconnect the neutral switch connector.
Remove the neutral switch and sealing washer.

Install a new sealing washer and tighten the neutral switch to the specified torque.

TORQUE: 12 N·m (1.2 kgf·m, 9 lbf·ft)

Connect the neutral switch connector securely.

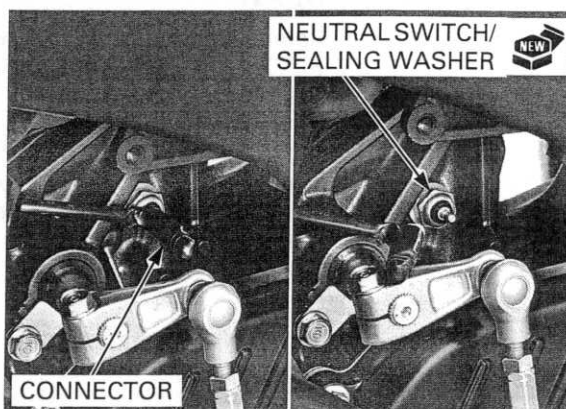

SIDESTAND SWITCH

INSPECTION

Remove the left middle cowl (page 3-8).

Disconnect the sidestand switch 2P (Green) connector.

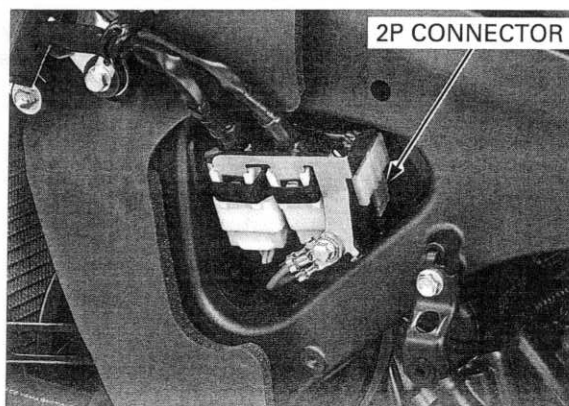

Check for continuity between the wire terminals of the sidestand switch 2P (Green) connector. Continuity should exist only when the sidestand is up.

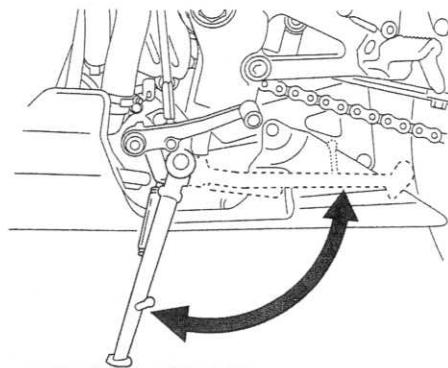

2P (Green) CONNECTOR
(Switch side of female terminals)

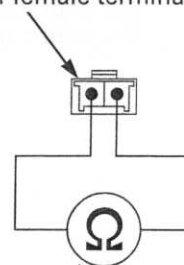

REMOVAL

Remove the following:

- Lower cowl (page 3-6)
- Left middle cowl (page 3-8)

Disconnect the sidestand switch 2P (Green) connector.

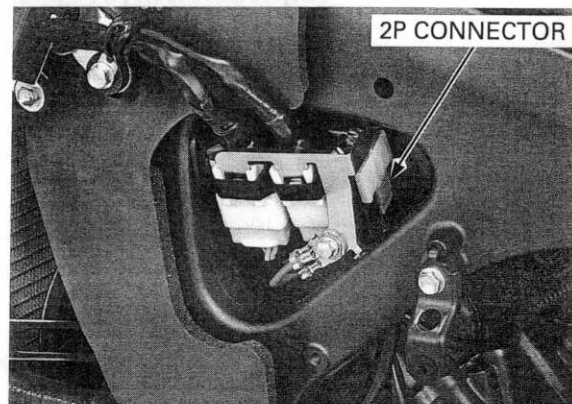

Remove the wire clamps and release the sidestand switch wire.

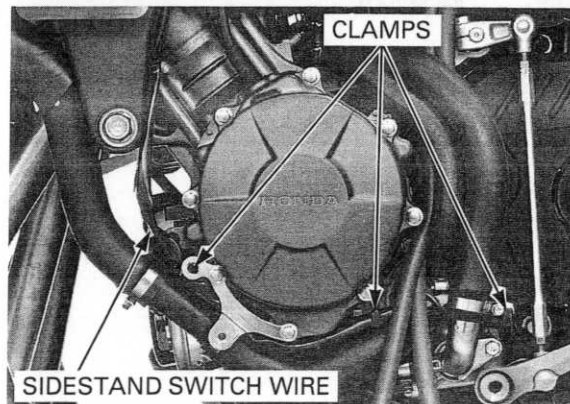

LIGHTS/METERS/SWITCHES

Remove the bolt and sidestand switch.

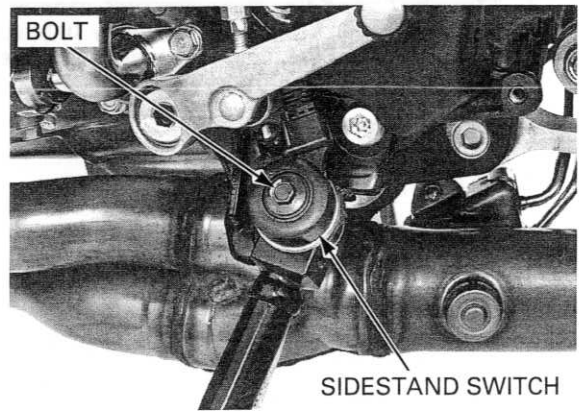

INSTALLATION

Install the rubber onto the sidestand pin securely.

Install the sidestand switch by aligning the switch pin with the sidestand hole and switch groove with the return spring holding pin.

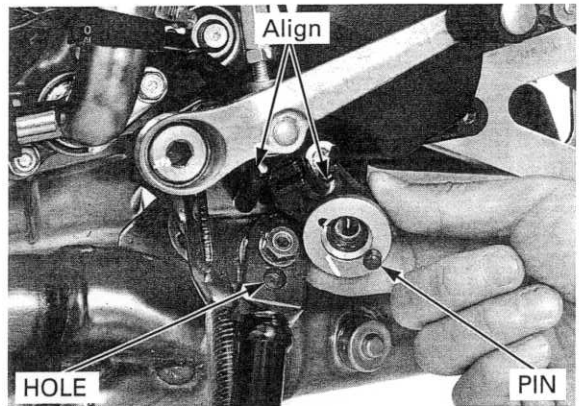

Secure the sidestand switch with a new bolt.

TORQUE: 10 N·m (1.0 kgf·m, 7 lbf·ft)

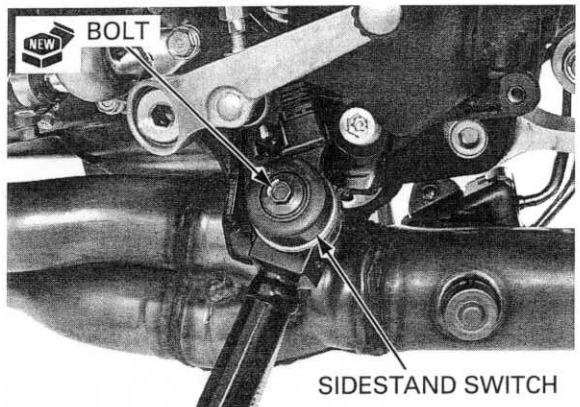

Route the wire properly (page 1-21).

Connect the sidestand switch 2P (Green) connector.

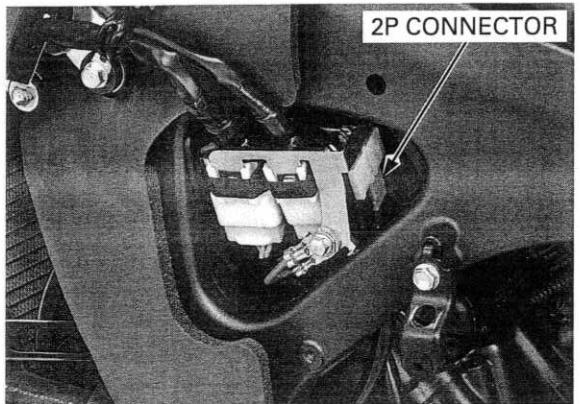

HORN

INSPECTION

Remove the right middle cowl (page 3-8).

Disconnect the horn connectors from the horn.

Connect a 12 V battery to the horn terminal directly. The horn is normal if it sounds when the 12 V battery is connected across the horn terminals.

Install the right middle cowl (page 3-8).

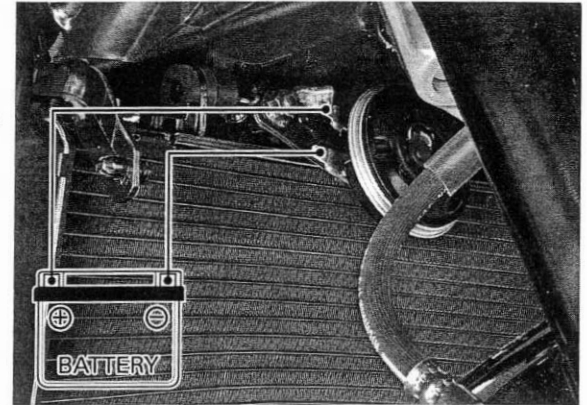

REMOVAL/INSTALLATION

Remove the right middle cowl (page 3-8).

Disconnect the horn connectors.

Remove the nut and horn.

Installation is in the reverse order of removal.

Route the wire properly (page 1-21).

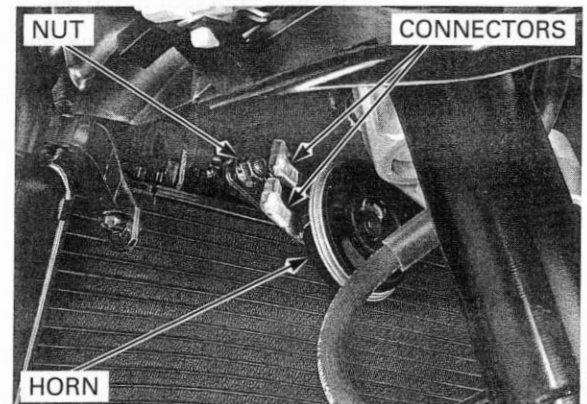

TURN SIGNAL RELAY

INSPECTION

1. Related Circuit Inspection

Remove the seat (page 3-4).

Check the following:

- Burned bulb or non-specified wattage
- Blown fuse (CLOCK/TURN 10 A, STOP/HORN 10 A)
- Ignition switch (page 20-17) and turn signal switch (page 20-18) function
- Loose connector

Are the above items in good condition?

NO - Replace or repair the failed part(s)

YES - GO TO STEP 2.

LIGHTS/METERS/SWITCHES

2. Turn Signal Circuit Inspection

Short the Brown/white and Gray terminals of the turn signal relay with a jumper wire. Turn the ignition switch ON and check the turn signal light by turning the turn signal switch on.

Does the light come on?

YES - • Faulty turn signal relay
• Loose or poor contact of the connector terminals

NO - Open circuit in White/green or Gray wires

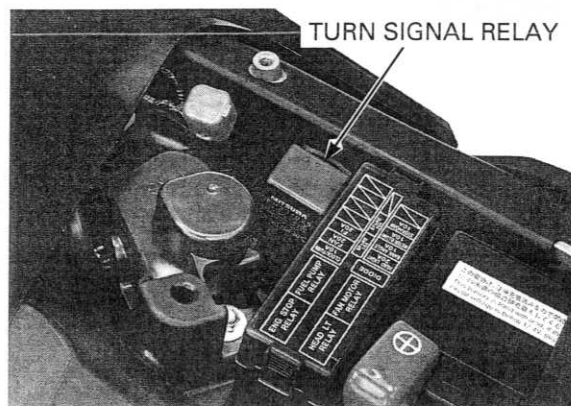

HEADLIGHT RELAY

INSPECTION

Remove the seat (page 3-4).

Open the fuse/relay box and remove the headlight relay.



Connect the ohmmeter to the headlight relay connector terminals.

Connect a 12 V battery to the headlight relay connector terminals as shown.

There should be continuity only when the 12 V battery is connected.

If there is no continuity when the 12 V battery is connected, replace the headlight relay.

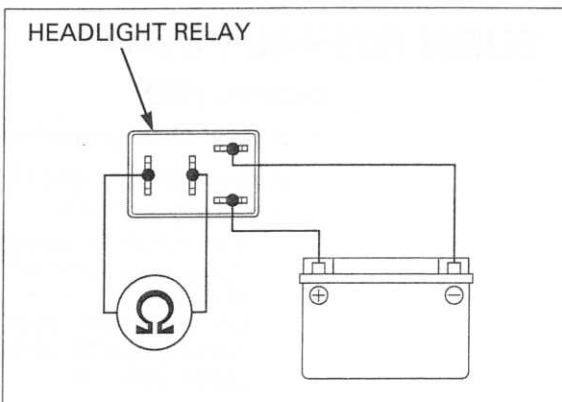

21. WIRING DIAGRAM

WIRING DIAGRAM 21-3

WIRING DIAGRAM

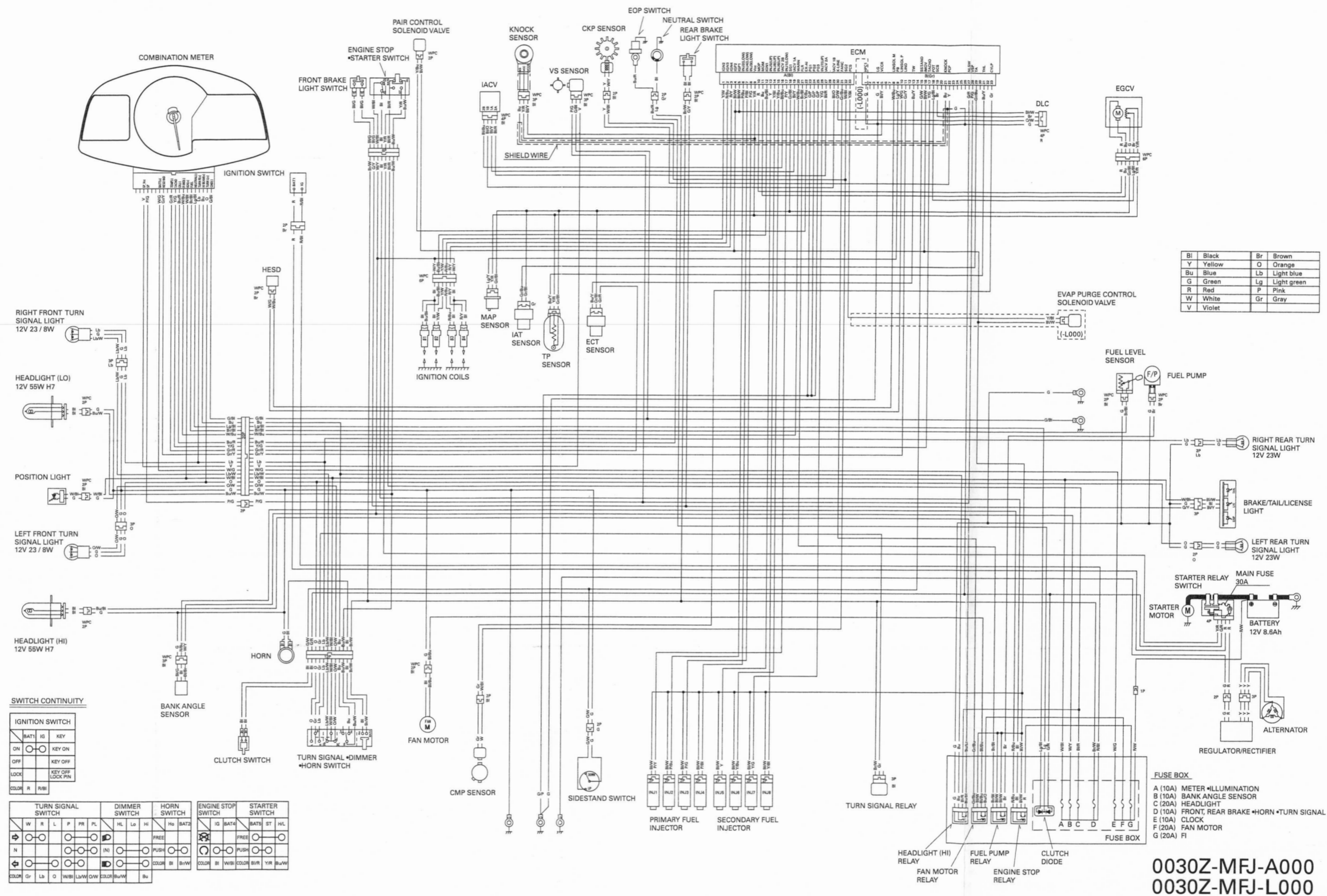

Bl	Black	Br	Brown
Y	Yellow	O	Orange
Bu	Blue	Lb	Light blue
G	Green	Lg	Light green
R	Red	P	Pink
W	White	Gr	Gray
V	Violet		

SWITCH CONTINUITY

IGNITION SWITCH	
BAT1	IG KEY
ON	KEY ON
OFF	KEY OFF
LOCK	KEY OFF LOCK PIN
COLOR	R / W/B

TURN SIGNAL SWITCH				DIMMER SWITCH		HORN SWITCH	
W	R	L	P	HL	Lo	Ho	BAT2
→	○	○	○	○	○	○	○
N				(N)		PUSH	
←	○	○	○	○	○	○	○
COLOR	Gr	Lb	O	W/B	Lb/W	QW	COLR
				COLR	Bu	Bu	

ENGINE STOP SWITCH		STARTER SWITCH	
IG	BAT4	BAT5	ST
○	○	○	○
		PUSH	
COLOR	Bl	COLR	Bu/R
		Y/R	Bu/W

- FUSE BOX
- A (10A) METER + ILLUMINATION
 - B (10A) BANK ANGLE SENSOR
 - C (20A) HEADLIGHT
 - D (10A) FRONT, REAR BRAKE + HORN + TURN SIGNAL
 - E (10A) CLOCK
 - F (20A) FAN MOTOR
 - G (20A) FI

0030Z-MFJ-A000
0030Z-MFJ-L000

MEMO

STANDARD FORM NO. 64

0000-1PM-5000
0000-1M-1000

22. TROUBLESHOOTING

ENGINE DOES NOT START OR IS HARD TO START 22-2

ENGINE LACKS POWER 22-3

POOR PERFORMANCE AT LOW AND IDLE SPEED 22-5

POOR PERFORMANCE AT HIGH SPEED 22-6

POOR HANDLING 22-6

ENGINE DOES NOT START OR IS HARD TO START

1. Spark Plug Inspection

Remove and inspect spark plug.

Are the spark plugs in good condition?

- NO** – • Incorrect spark plug heat range
• Incorrect spark plug gap
• Dirty air cleaner

YES – GO TO STEP 2.

2. Spark Test

Perform spark test.

Are there good sparks?

- NO** – • Loose or disconnected ignition system wire
• Faulty direct ignition coil
• Broken or shorted direct ignition coil connector wire
• Faulty CKP sensor
• Faulty engine stop switch
• Faulty ECM

YES – GO TO STEP 3.

3. Fuel Pump Inspection

Check for operation of the fuel pump and inspect the fuel flow.

Is the fuel pump unit normal?

- NO** – Faulty fuel pump unit (page 6-47)

YES – GO TO STEP 4.

4. Programmed Fuel Injection System Inspection

Check the fuel injection system.

Is the fuel injection system normal?

- NO** – Faulty fuel injection system (primary: page 6-65, secondary: page 6-56)

YES – GO TO STEP 5.

5. Cylinder compression Inspection

Test the cylinder compression.

Is the compression specified?

- NO** – • Valve stuck open
• Worn cylinder and piston rings
• Damaged cylinder head gasket
• Seized valves
• Improper valve timing

YES – GO TO STEP 6.

6. Engine Start Condition

Start by following normal procedure.

Did the engine start but stops?

- YES** – • Leaking intake manifold
• Leaking intake pipes
• Faulty IACV
• Improper ignition timing (Faulty ECM or CKP sensor)
• Contaminated fuel

ENGINE LACKS POWER

1. Drive Train Inspection

Raise wheel off the ground and spin by hand.

Did the wheel spin freely?

- NO** – • Brake dragging
• Worn or damaged wheel bearings

YES – GO TO STEP 2.

2. Tire Pressure Inspection

Check the tire pressure.

Is the tire pressure correct?

- NO** – • Faulty tire valve
• Punctured tire

YES – GO TO STEP 3.

3. Clutch Inspection

Accelerate rapidly, shift from first to second.

Did the engine speed change accordingly when clutch is released?

- NO** – • Clutch slipping
• Worn clutch discs/plates
• Warped clutch discs/plates
• Weak clutch spring
• Additive in engine oil

YES – GO TO STEP 4.

4. Engine Performance Inspection

Accelerate lightly.

Did the Engine speed increase?

- NO** – • Dirty air cleaner
• Restricted fuel flow
• Clogged muffler

YES – GO TO STEP 5.

5. Spark Plug Inspection

Remove and inspect spark plugs.

Are the spark plugs in good condition?

- NO** – • Plugs not serviced frequently enough
• Incorrect spark plug heat range
• Incorrect spark plug gap

YES – GO TO STEP 6.

6. Engine Oil Inspection

Check the oil level and condition.

Is the engine oil in good condition?

- NO** – • Oil level too high
• Oil level too low
• Contaminated oil

YES – GO TO STEP 7.

TROUBLESHOOTING

7. Ignition Timing Inspection

Check the ignition timing.

Is the ignition timing as specified?

- NO** – • Faulty ECM
• Faulty CKP sensor
• Faulty CMP sensor
• Faulty knock sensor
• Improper valve timing

YES – GO TO STEP 8.

8. Cylinder compression Inspection

Test the cylinder compression.

Is the compression as specified?

- NO** – • Valve clearance too small
• Valve stuck open
• Worn cylinder and piston rings
• Damaged cylinder head gasket
• Improper valve timing

YES – GO TO STEP 9.

9. Fuel Pump Inspection

Inspect the fuel flow.

Is the fuel pump unit normal?

- NO** – Faulty fuel pump unit (page 6-47)

YES – GO TO STEP 10.

10. Programmed Fuel Injection System Inspection

Check the fuel injection system.

Is the fuel injection system normal?

- NO** – Faulty fuel injection system (primary: page 6-65, secondary: page 6-56)

YES – GO TO STEP 11.

11. Lubrication Inspection

Remove cylinder head cover and inspect lubrication.

Is the valve train lubricated properly?

- NO** – • Faulty oil pump
• Faulty pressure relief valve
• Clogged oil strainer
• Clogged oil passage

YES – GO TO STEP 12.

12. Over Heating Inspection

Check for engine over heating.

Is the engine over heating?

- YES** – • Coolant level too low
• Fan motor not working
• Thermostat stuck closed
• Excessive carbon build-up in combustion chamber
• Use of poor quality fuel
• Wrong type of fuel
• Clutch slipping

NO – GO TO STEP 13.

13. Engine Knocking Inspection

Accelerate or run at high speed.

Is the engine knocking?

- YES** –
- Worn piston and cylinder
 - Wrong type of fuel
 - Excessive carbon build-up in combustion chamber
 - Ignition timing too advance (Faulty ECM)
 - Faulty CKP sensor
 - Faulty CMP sensor
 - Faulty knock sensor
- NO** – Engine does not knock

POOR PERFORMANCE AT LOW AND IDLE SPEED**1. Spark Plug Inspection**

Remove and inspect spark plugs.

Are the spark plugs in good condition?

- NO** –
- Plugs not serviced frequently enough
 - Incorrect spark plug heat range
 - Incorrect spark plug gap
- YES** – GO TO STEP 2.

2. Ignition Timing Inspection

Check the ignition timing.

Is the ignition timing as specified?

- NO** –
- Faulty ECM
 - Faulty CKP sensor
 - Faulty CMP sensor
 - Faulty VS sensor
 - Faulty knock sensor
 - Improper valve timing
- YES** – GO TO STEP 3.

3. Fuel Pump Inspection

Inspect the fuel flow.

Is the fuel pump unit normal?

- NO** – Faulty fuel pump unit (page 6-47)
- YES** – GO TO STEP 4.

4. Programmed Fuel Injection System Inspection

Check the fuel injection system.

Is the fuel injection system normal?

- NO** – Faulty fuel injection system (primary: page 6-65, secondary: page 6-56)
- YES** – GO TO STEP 5.

5. Intake Pipes Leaking Inspection

Check for leaks at the intake manifold pipes.

Are there leaks?

- YES** –
- Loose insulator
 - Damaged insulator

POOR PERFORMANCE AT HIGH SPEED

1. Ignition Timing Inspection

Check the ignition timing.

Is the ignition timing as specified?

- NO** – • Faulty ECM
• Faulty CKP sensor
• Faulty CMP sensor
• Faulty VS sensor
• Faulty knock sensor
• Improper valve timing

YES – GO TO STEP 2.

2. Fuel Pump Inspection

Inspect the fuel flow.

Is the fuel pump unit operation normal?

NO – Faulty fuel pump unit (page 6-47)

YES – GO TO STEP 3.

3. Programmed Fuel Injection System Inspection

Check the fuel injection system.

Is the fuel injection system normal?

NO – Faulty fuel injection system (primary: page 6-65, secondary: page 6-56)

YES – GO TO STEP 4.

4. Valve Timing Inspection

Check the valve timing.

Is the valve timing correct?

NO – Camshafts not installed properly

YES – GO TO STEP 5.

5. Valve Spring Inspection

Check for the valve springs.

Is the valve spring free length as specified?

NO – Faulty valve springs

YES – Not weak

POOR HANDLING

Steering is heavy

- Steering stem adjusting nut too tight
- Damaged steering head bearings
- Low tire pressure
- Faulty HESD

Either wheel is wobbling

- Excessive wheel bearing play
- Bent rim
- Swingarm pivot bearing excessively worn
- Bent frame

The motorcycle pulls to one side

- Front and rear wheel not aligned
- Faulty shock absorber
- Bent fork
- Bent swingarm
- Bent axle
- Bent frame

AIR CLEANER.....	4-8	DTC INDEX.....	6-16
AIR CLEANER HOUSING.....	6-52	DTC TROUBLESHOOTING.....	6-18
AIR DUCT.....	3-12	ECM.....	6-74
ALTERNATOR CHARGING COIL.....	17-8	ECT SENSOR	
ALTERNATOR COVER INSTALLATION.....	11-6	FUEL SYSTEM (PGM-FI).....	6-71
ALTERNATOR COVER REMOVAL.....	11-4	LIGHTS/METERS/SWITCHES.....	20-14
BANK ANGLE SENSOR.....	6-72	EGCV.....	6-83
BATTERY.....	17-6	EGCV CABLE.....	4-22
BATTERY/CHARGING SYSTEM SPECIFICATIONS.....	1-11	EGCV SERVOMOTOR.....	6-80
BODY PANEL LOCATIONS.....	3-2	ELECTRIC STARTER SPECIFICATIONS.....	1-11
BRAKE FLUID.....	4-28	EMISSION CONTROL SYSTEMS.....	1-36
BRAKE FLUID REPLACEMENT/AIR BLEEDING.....	16-7	ENGINE & FRAME TORQUE VALUES.....	1-13
BRAKE LIGHT SWITCH		ENGINE DOES NOT START OR IS HARD TO	
LIGHTS/METERS/SWITCHES.....	20-19	START.....	22-2
MAINTENANCE.....	4-31	ENGINE IDLE SPEED.....	6-67
BRAKE PAD/DISC.....	16-9	ENGINE INSTALLATION.....	8-9
BRAKE PADS WEAR.....	4-29	ENGINE LACKS POWER.....	22-3
BRAKE PEDAL.....	16-31	ENGINE OIL/OIL FILTER.....	4-17
BRAKE SYSTEM.....	4-30	ENGINE REMOVAL.....	8-4
BRAKE/TAIL/LICENSE LIGHT.....	20-7	ENGINE STOP RELAY.....	6-74
CABLE & HARNESS ROUTING.....	1-21	EOP SWITCH.....	20-14
CAM CHAIN TENSIONER LIFTER.....	9-35	EVAP PURGE CONTROL SOLENOID VALVE/ CANISTER (CALIFORNIA TYPE).....	6-79
CAMSHAFT INSTALLATION.....	9-28	EVAPORATIVE EMISSION CONTROL SYSTEM (CALIFORNIA TYPE).....	4-21
CAMSHAFT REMOVAL.....	9-9	EXHAUST PIPE.....	3-24
CHARGING SYSTEM INSPECTION.....	17-7	FAN MOTOR RELAY.....	7-20
CKP SENSOR.....	18-7	FLYWHEEL.....	11-5
CLUTCH.....	10-7	FORK.....	14-22
CLUTCH SWITCH.....	20-19	FRONT BRAKE CALIPERS.....	16-25
CLUTCH SYSTEM.....	4-31	FRONT FENDER.....	3-13
CLUTCH/STARTER CLUTCH/GEARSHIFT LINKAGE SPECIFICATIONS.....	1-8	FRONT MASTER CYLINDER.....	16-13
CMP SENSOR.....	6-71	FRONT WHEEL.....	14-16
COMBINATION METER.....	20-7	FRONT WHEEL/SUSPENSION/STEERING SPECIFICATIONS.....	1-10
COMPONENT LOCATION		FUEL LEVEL SENSOR.....	20-16
ALTERNATOR.....	11-2	FUEL LINE.....	4-5
CLUTCH/STARTER CLUTCH/ GEARSHIFT LINKAGE.....	10-2	FUEL LINE INSPECTION.....	6-42
CRANKCASE/TRANSMISSION.....	12-2	FUEL PUMP RELAY.....	6-49
CRANKSHAFT/PISTON/CYLINDER.....	13-2	FUEL PUMP UNIT.....	6-47
CYLINDER HEAD/VALVES.....	9-2	FUEL SYSTEM (PGM-FI) SPECIFICATIONS.....	1-7
ENGINE REMOVAL/INSTALLATION.....	8-2	FUEL TANK.....	6-50
FRONT WHEEL/SUSPENSION/STEERING.....	14-2	FUEL TANK COVER/SIDE COVER.....	3-9
FUEL SYSTEM (PGM-FI).....	6-2	GEARSHIFT LINKAGE.....	10-23
HYDRAULIC BRAKE.....	16-2	GENERAL SPECIFICATIONS.....	1-5
REAR WHEEL SUSPENSION.....	15-2	HANDLEBAR SWITCHES.....	20-17
CONNECTOR LOCATION.....	6-10	HANDLEBARS.....	14-10
COOLANT REPLACEMENT.....	7-6	HEADLIGHT.....	20-6
COOLING SYSTEM.....	4-20	HEADLIGHT AIM.....	4-31
COOLING SYSTEM SPECIFICATIONS.....	1-7	HEADLIGHT RELAY.....	20-24
CRANKCASE ASSEMBLY.....	12-16	HESD.....	14-33
CRANKCASE SEPARATION.....	12-5	HESD TROUBLESHOOTING.....	14-8
CRANKCASE/TRANSMISSION SPECIFICATIONS.....	1-9	HORN.....	20-23
CRANKPIN BEARING.....	13-11	HYDRAULIC BRAKE SPECIFICATIONS.....	1-11
CRANKSHAFT.....	13-5	IACV	
CRANKSHAFT/PISTON/CYLINDER SPECIFICATIONS.....	1-9	FUEL SYSTEM (PGM-FI).....	6-68
CYLINDER COMPRESSION TEST.....	9-7	TECHNICAL FEATURES.....	2-2
CYLINDER HEAD ASSEMBLY.....	9-24	IAT SENSOR.....	6-71
CYLINDER HEAD COVER ASSEMBLY.....	9-33	IGNITION SWITCH.....	20-17
CYLINDER HEAD COVER DISASSEMBLY.....	9-8	IGNITION SYSTEM INSPECTION.....	18-5
CYLINDER HEAD COVER INSTALLATION.....	9-34	IGNITION SYSTEM SPECIFICATIONS.....	1-11
CYLINDER HEAD COVER REMOVAL.....	9-7	IGNITION TIMING.....	18-7
CYLINDER HEAD DISASSEMBLY.....	9-16	KNOCK SENSOR	
CYLINDER HEAD INSPECTION.....	9-17	FUEL SYSTEM (PGM-FI).....	6-69
CYLINDER HEAD INSTALLATION.....	9-26	TECHNICAL FEATURES.....	2-4
CYLINDER HEAD REMOVAL.....	9-14	LIGHTS/METERS/SWITCHES SPECIFICATIONS.....	1-12
CYLINDER HEAD/VALVES SPECIFICATIONS.....	1-8	LOWER COWL.....	3-6
DIODE.....	19-16	LUBRICATION & SEAL POINTS.....	1-19
DRIVE CHAIN.....	4-23	LUBRICATION SYSTEM DIAGRAM.....	5-2

INDEX

LUBRICATION SYSTEM SPECIFICATIONS.....	1-7	IGNITION SYSTEM.....	18-3
MAIN JOURNAL BEARING.....	13-8	LIGHTS/METERS/SWITCHES.....	20-3
MAINTENANCE SCHEDULE.....	4-4	LUBRICATION SYSTEM.....	5-3
MAP SENSOR.....	6-70	MAINTENANCE.....	4-2
MIDDLE COWL.....	3-8	REAR WHEEL SUSPENSION.....	15-3
MIL CIRCUIT TROUBLESHOOTING.....	6-42	SERVICE RULES.....	1-2
MODEL IDENTIFICATION.....	1-3	SHIFT FORK/SHIFT DRUM/TRANSMISSION.....	12-6
MUFFLER.....	3-19	SHOCK ABSORBER.....	15-14
NEUTRAL SWITCH.....	20-20	SIDESTAND.....	4-32
NUTS, BOLTS, FASTENERS.....	4-35	SIDESTAND SWITCH.....	20-20
OIL COOLER.....	5-13	SPARK PLUG.....	4-9
OIL PRESSURE INSPECTION.....	5-5	SPEEDOMETER/VS SENSOR.....	20-11
OIL PUMP.....	5-7	STANDARD TORQUE VALUES.....	1-13
OIL STRAINER/PRESSURE RELIEF VALVE.....	5-5	STARTER CLUTCH.....	10-17
PASSENGER SEAT.....	3-4	STARTER MOTOR.....	19-6
PGM-FI SYMPTOM TROUBLESHOOTING.....	6-7	STARTER RELAY SWITCH.....	19-14
PGM-FI SYSTEM DIAGRAM.....	6-9	STATOR.....	11-4
PGM-FI SYSTEM LOCATION.....	6-8	STEERING HEAD BEARINGS.....	4-36
PGM-FI TROUBLESHOOTING INFORMAITON.....	6-13	STEERING STEM.....	14-34
PISTON/CYLINDER.....	13-14	SUSPENSION.....	4-32
POOR HANDLING.....	22-6	SUSPENSION LINKAGE.....	15-19
POOR PERFORMANCE AT HIGH SPEED.....	22-6	SWINGARM.....	15-20
POOR PERFORMANCE AT LOW AND		SYSTEM DIAGRAM	
IDLE SPEED.....	22-5	BATTERY/CHARGING SYSTEM.....	17-2
PRIMARY INJECTOR.....	6-65	ELECTRIC STARTER.....	19-2
RADIATOR.....	7-11	IGNITION SYSTEM.....	18-2
RADIATOR COOLANT.....	4-19	SYSTEM FLOW PATTERN.....	7-2
RADIATOR RESERVE TANK.....	7-20	SYSTEM LOCATION.....	20-2
REAR BRAKE CALIPER.....	16-28	SYSTEM TESTING.....	7-5
REAR COWL.....	3-5	TACHOMETER.....	20-12
REAR FENDER A.....	3-13	THERMOSTAT HOUSING.....	7-8
REAR FENDER B.....	3-14	THROTTLE BODY.....	6-60
REAR FENDER C.....	3-16	THROTTLE OPERATION.....	4-8
REAR MASTER CYLINDER.....	16-19	TROUBLESHOOTING	
REAR WHEEL.....	15-7	BATTERY/CHARGING SYSTEM.....	17-5
REAR WHEEL/SUSPENSION SPECIFICATIONS.....	1-10	CLUTCH/STARTER CLUTCH/	
REARVIEW MIRROR.....	3-10	GEARSHIFT LINKAGE.....	10-4
REGULATOR/RECTIFIER.....	17-8	COOLING SYSTEM.....	7-4
RIGHT CRANKCASE COVER INSTALLATION.....	10-26	CRANKCASE/TRANSMISSION.....	12-4
RIGHT CRANKCASE COVER REMOVAL.....	10-5	CRANKSHAFT/PISTON/CYLINDER.....	13-4
SEAT.....	3-4	CYLINDER HEAD/VALVES.....	9-6
SEAT RAIL.....	3-16	ELECTRIC STARTER.....	19-4
SECONDARY AIR SUPPLY SYSTEM		FRAME/BODY PANELS/EXHAUST SYSTEM.....	3-3
FUEL SYSTEM (PGM-FI).....	6-77	FRONT WHEEL/SUSPENSION/STEERING.....	14-7
MAINTENANCE.....	4-20	HYDRAULIC BRAKE.....	16-6
SECONDARY INJECTOR.....	6-56	IGNITION SYSTEM.....	18-4
SERVICE INFORMATION		LIGHTS/METERS/SWITCHES.....	20-5
ALTERNATOR.....	11-3	LUBRICATION SYSTEM.....	5-4
BATTERY/CHARGING SYSTEM.....	17-3	REAR WHEEL SUSPENSION.....	15-6
CLUTCH/STARTER CLUTCH/		TURN SIGNAL LIGHT.....	20-7
GEARSHIFT LINKAGE.....	10-3	TURN SIGNAL RELAY.....	20-23
COOLING SYSTEM.....	7-3	UPPER COWL/FRONT SPOILER.....	3-11
CRANKCASE/TRANSMISSION.....	12-3	UPPER INNER COWL/HEADLIGHT COVER.....	3-7
CRANKSHAFT/PISTON/CYLINDER.....	13-3	VALVE CLEARANCE.....	4-13
CYLINDER HEAD/VALVES.....	9-3	VALVE GUIDE REPLACEMENT.....	9-20
ELECTRIC STARTER.....	19-3	VALVE SEAT INSPECTION/REFACING.....	9-21
ENGINE REMOVAL/INSTALLATION.....	8-3	WATER PUMP.....	7-16
FRAME/BODY PANELS/EXHAUST SYSTEM.....	3-3	WHEELS/TIRES.....	4-35
FRONT WHEEL/SUSPENSION/STEERING.....	14-3	WINDSCREEN.....	3-10
FUEL SYSTEM (PGM-FI).....	6-3	WIRING DIAGRAM.....	21-3
HYDRAULIC BRAKE.....	16-4		