

SUZUKI

GN125F

SERVICE MANUAL

FOREWORD

This manual contains an introductory description on the SUZUKI GN125F and procedures for its inspection/service and overhaul of its main components. Other information considered as generally known is not included.

Read the GENERAL INFORMATION section to familiarize yourself with the motorcycle and its maintenance. Use this section as well as other sections to use as a guide for proper inspection and service.

This manual will help you know the motorcycle better so that you can assure your customers of fast and reliable service.

* This manual has been prepared on the basis of the latest specifications at the time of publication. If modifications have been made since then, differences may exist between the content of this manual and the actual motorcycle.

* Illustrations in this manual are used to show the basic principles of operation and work procedures. They may not represent the actual motorcycle exactly in detail.

* This manual is written for persons who have enough knowledge, skills and tools, including special tools, for servicing SUZUKI motorcycles. If you do not have the proper knowledge and tools, ask your authorized SUZUKI motorcycle dealer to help you.

WARNING

Improper repair may result in injury to the mechanic and may render the motorcycle unsafe for the rider and passenger.

CAUTION

Inexperienced mechanics or mechanics without proper tools, not to able to properly perform the services described in this manual.

DACHANGJIANG GROUP CO.,LTD.
DECEMBER, 2014
(The 1st Edition)

GROUP INDEX

GENERAL INFORMATION

1

PERIODIC MAINTENANCE

2

ENGINE

3

FUEL AND LUBRICATION

4

CHASSIS

5

ELECTRICAL

6

SERVICING INFORMATION

7

HOW TO USE THIS MANUAL

TO LOCATE WHAT YOU ARE LOOKING FOR:

1. The text of this manual is divided into 7 sections.
2. The section titles are listed in the GROUP INDEX.
3. Holding the manual as shown as at the right will allow you to find the first page of the section easily.
4. The contents are listed on the first page of each section to help you find the item and page you need.

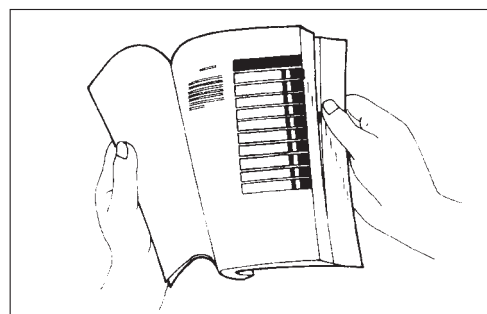

COMPONENT PARTS AND WORK TO BE DONE

Under the name of each system or unit, is its exploded view. Work instruction and tightening torque, lubricating points and locking points, are provided.

Example: Front wheel

①	Front axle shaft
②	Spacer
③	Dustcover
④	Washer
⑤	Front brake disc
⑥	Oil seal
⑦	Roller bearing
⑧	Spacer
⑨	Front tire
⑩	Front wheel rim
⑪	Speedometer gear driver
⑫	Oil seal
⑬	Speedometer gear box
A	Brake disc bolt
B	Front axle nut





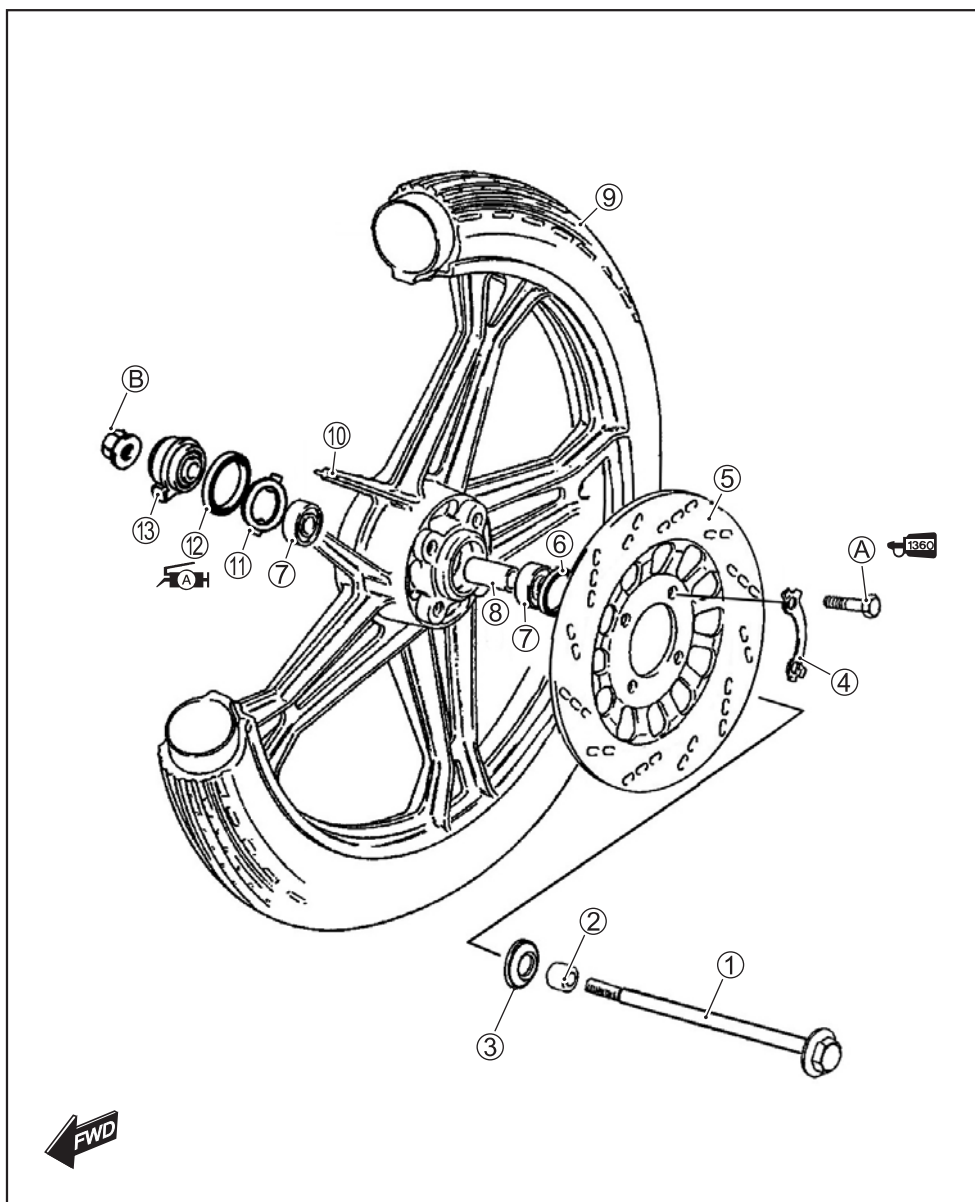













ITEM	N•m	Kgf•m
A	18-28	1.8-2.8
B	36-52	3.6-5.2



SYMBOL

The following symbols are instructions and necessary information for maintenance.

SYMBOL	DEFINITION	SYMBOL	DEFINITION
	Torque control required. Data beside it indicates specified torque.		Apply THREAD LOCK "1360" 99000-32130
	Apply oil. Use engine oil unless otherwise specified.		Apply or use the absorber oil
	Apply SUPER GREASE "A" 99000-25010		Apply or use the brake fluid
	Apply MOLY PASTE 99000-25140		Measure voltage
	Apply sealant "1215" 99000-31110		Measure in resistance
	Apply sealant "1207B" 99000-31140		Measure continuity test range
	Apply THREAD LOCK "1342" 99000-32050		Use special tool
	Apply THREAD LOCK "1303" 99000-32030		The data of maintenance

WIRE COLOR

B	Black	Gr.....	Green	R	Red
Bl	Blue	Lbl.....	Light blue	V	Violet
Br	Brown	Lg.....	Light green	W	White
Dg.....	Deep green	O	Orange	Y	Yellow
G	Green	P	Pink		

B/Bl	Black with Blue tracer	O/Bl	Orange with Blue tracer
B/Br	Black with Brown tracer	O/W	Orange with White tracer
B/G	Black with Green tracer	O/Y	Orange with Yellow tracer
B/R	Black with Red tracer	R/B	Red with Black tracer
B/W	Black with White tracer	R/Y	Red with Yellow tracer
B/Y	Black with Yellow tracer	W/B	White with Black tracer
Bl/W	Blue with White tracer	W/R	White with Red tracer
Bl/Y	Black with Yellow tracer	Y/G	Yellow with Green tracer
Br/Y	Brown with Yellow tracer	Y/R	Yellow with Red tracer
G/Y	Green with Yellow tracer	Y/W	Yellow with White tracer
O/B	Orange with Black tracer		

GENERAL INFORMATION

1

CONTENTS

WARNING/CAUTION/NOTE	1-1
GENERAL PRECAUTIONS.....	1-1
SERIAL NUMBER LOCATION	1-2
FUEL AND OIL RECOMMENDATION	1-2
BREAK-IN PROCEDURE	1-2
SPECIFICATIONS	1-3

WARNING/CAUTION/NOTE

Please read this manual and follow its instructions carefully. To emphasize special information, the symbol and the words WARNING, CAUTION and NOTE have special meanings. Pay special attention to the messages highlighted by these signal words.

WARNING

Indicates a potential hazard that could result in death or injury.

CAUTION

Indicates a potential hazard that could result in motorcycle damage.

NOTE:

Indicates special information to make maintenance easier or instructions clearer.

Please note, however, that the warnings and the cautions contained in this manual cannot possibly cover all potential hazards relating to the servicing, or lack of servicing of the motorcycle. In addition to the WARNING and CAUTION stated, you must use good judgment and basic mechanical safety principles. If you are unsure about how to perform a particular service operation, ask a more experienced technician for advice.

GENERAL PRECAUTION

WARNING

- Proper service and repair procedures are important for the safety of the service technician and the safety and reliability of the motorcycle.
- When 2 or more persons work together, pay attention to safety of each other.
- When it is necessary to run the engine indoors, make sure that exhaust gas is forced outdoor.
- When working with the toxic or flammable materials, make sure that the area you work in is well-ventilated and that you follow all of the material manufacturer's instructions.
- Never use gasoline as a cleaning solvent.
- To avoid getting burned, do not touch the engine, engine oil or exhaust system during or for a while after engine operation.
- After servicing fuel, oil, exhaust or brake system, check all lines and fittings related to the system for leakage.

GENERAL INFORMATION

CAUTION

- If parts replacement is necessary, replace the parts with SUZUKI GENUINE PARTS or their equivalent.
- When removing parts that are to be reused, keep them arranged in an orderly manner so that they may be reinstalled in the proper order and orientation.
- Be sure to use special tools when instructed.
- Make sure that all parts used in reassembly are clean, and also lubricated when specified.
- When use of a certain type of lubricant, bond, or sealant is specified, be sure to use the specified type.
- When performing service to electrical parts, if the service procedures not require used of battery power, disconnect the positive terminal.
- When removing the battery, disconnect the negative cable first and then the positive cable.
- When reconnecting the battery, connect the positive cable first and then the negative cable, and replace the terminal cover on the positive terminal.
- Tighten cylinder head and case bolts and nuts, beginning with larger diameter and ending with smaller diameter, from inside to outside diagonally, to the specified tightening torque.
- Whenever you remove oil seals, gaskets, packing, O-rings, locking washers, cotter pins, cir-clips, and certain other parts as specified, be sure to replace them with new ones. Also, before installing these new parts, be sure to remove any odd material from the mating surfaces.
- Never reuse a circlip. When installing a new circlip, take care not to expend the end gap larger than required to slip the circlip over the shaft. After installing a circlip, always ensure that it is completely seated in its groove and securely fitted.
- Do not use self-locking nuts a few times over.
- Use a torque wrench to tighten fasteners to the torque values when specified. Wipe off grease or oil if a thread is smeared with them.
- After reassembly, check parts for tightness and operation.

NOTE:

- * **To protect environment, do not unlawfully dispose of used motor oil and other fluids, batteries and tires.**
- * **To protect earth's natural resources, properly dispose of used motorcycles and parts.**

SERIAL NUMBER LOCATIONS

The frame serial number or V.I.N. (Vehicle Identification Number) ① is stamped on the right side of the steering head pipe. The engine serial number ② is located on the left side of the crankcase. These numbers are required especially for registering the machine and ordering spare parts.

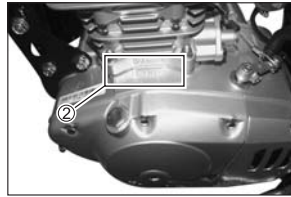
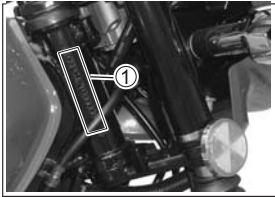

FUEL AND OIL RECOMMENDATIONS

FUEL

Use fuel with an octane number of 90-97 (Research method), preferably unleaded.

NOTE:

Unleaded fuel will extend spark plug life.

ENGINE OIL

Be sure that the motorcycle engine oil you use comes under API classification of SF or SG and its viscosity rating is SAE 10W-40. If SAE 10W-40 engine oil is not available, select the oil viscosity according to the following chart:

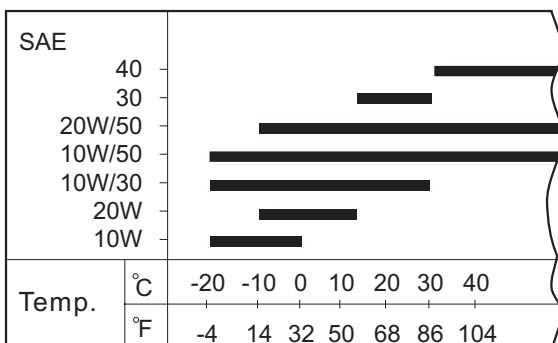

BRAKE FLUID

DOT4

ABSORBER OIL

SUZUKI ABSORBER OIL #32 OR EQUIVALENT

BREAK-IN PROCEDURE

During the manufacture only the best possible materials are used and all machined parts are finished to a very high standard, it is still necessary to allow the moving part to “BREAK-IN” before subjecting the engine to maximum stresses. The future performance and reliability of the engine depends on the care and restraint exercised during its early life . The general rules are as follows:

- The throttle must not be opened to the full during the new motorcycle's break-in period. Throttle opening should be limited to less than 3/4 of its maximum, while violent acceleration should be avoided.
- Do not maintain constant engine gear and speed for an extended time period during any portion of the break-in. Try to vary the throttle position. During the period of break-in, increase the throttle opening properly to enable break-in fully.
- When engine is running at constant low speed (low load), parts will wear rapidly leads to bad brake-in.

SPECIFICATIONS

DIMENSIONS AND CURB WEIGHT

Overall length.....	2 000 mm
Overall width.....	815 mm
Overall height.....	1 100 mm
Wheelbase.....	1 300 mm
Ground clearance.....	175 mm
Curb weight.....	113 kg

ENGINE

Type.....	Single cylinder, vertical, air-cooled, four stroke
Number of cylinders.....	1
Bore.....	57 mm
Stroke.....	48.8 mm
Piston displacement.....	124 ml
Compression ratio.....	9.2 : 1
Carburetor.....	BS type
Air cleaner.....	Polyurethane foam element
Starter system.....	Electric
Lubrication system.....	Wet sump

TRANSMISSION

Clutch.....	Wet multi-plate type
Transmission.....	5-speed constant mesh
Primary reduction ratio.....	3.470
Final reduction ratio.....	2.867
Gear ratios, Low.....	3.000
2nd.....	1.857
3rd.....	1.368
4th.....	1.143
Top.....	0.957
Drive chain.....	KMC 428H 116 links

ELECTRIC

Ignition type	CDI
Ignition timing	13° B.T.D.C below 2 000 r/min
Spark plug	NGK CR8E
Battery	12V 7Ah
Fuse	15 A
Headlight	12V, 35W/35W
Tail light/brake light	12V, 5W/21W
Turn signal light	12V, 10W
Position light	12V, 5W

CHASSIS

Front absorber	Telescopic, coil spring, oil damped
Rear absorber	Swingarm type, 5 level adjustable coil spring oil damped
Steering angle	42°
Caster	27° 50'
Trail	105 mm
Turning diameter	4 200 mm
Front brake	Disc brake
Rear brake	Drum brake
Front tire size	2.75-18 4PR
Rear tire size	3.50-16 4PR
Front absorber stroke	130 mm

CAPACITIES

Fuel tank	10 L
Reserve	2 L
Engine oil, oil change	850 ml
with filter change	950 ml
Overhaul	1 300 ml
Front absorber oil (single)	168 ml

*The specifications subject to change without notice.

PERIODIC MAINTENANCE

CONTENTS

PERIODIC MAINTENANCE	2-1
MAINTENANCE PROCEDURES	2-3
BATTERY/FUSE	2-3
AIR FILTER	2-4
MUFFLER NUT AND BOLT	2-5
CYLINDER HEAD, CYLINDER BOLTS AND NUTS	2-5
VALVE CLEARANCE	2-5
SPARK PLUG	2-6
ENGINE OIL	2-7
ENGINE OIL FILTER	2-7
OIL SUMP FILTER	2-8
CLUTCH CABLE PLAY	2-8
CARBURETOR(IDLING)	2-8
THROTTLE CABLE PLAY	2-9
FUEL HOSE	2-9
FUEL STRAINER	2-9
DRIVE CHAIN	2-10
BRAKES	2-11
TIRES	2-14
STEERING	2-14
FRONT AND REAR ABSORBER	2-14
LIGHTING AND SIGNAL	2-15
CHASSIS AND ENGINE MOUNTING BOLTS AND NUTS	2-15
COMPRESSION PRESSURE INSPECTION	2-17
OIL PRESSURE INSPECTION	2-18

PERIODIC MAINTENANCE

The chart below lists recommended intervals for all the required periodic service work necessary to keep the motorcycle operating at peak performance and economy. Mileages are expressed in terms of kilometer and time for your convenience.

NOTE:

More frequent servicing may be performed on motorcycles that are used under severe conditions.

PERIODIC MAINTENANCE CHART

Item	Interval		Initial	Every 5 000	Every 10 000	PAGE
	Km	Month	1 000	6	12	
Battery / Fuse			Inspect	Inspect	—	2-3
Air cleaner			Clean every 3 000 km			2-4
Muffler bolts			Tighten	Tighten	—	2-5
Cylinder head and cylinder nuts			Tighten	Tighten	—	2-5
Valve clearance (when cold)			Inspect	Inspect	—	2-5
Spark plug			Inspect	Inspect	—	2-6
			Replace every 10 000 km			
Engine oil			Change	Change	—	2-7
Engine oil filter			Replace	Replace	—	2-7
Oil sump filter			—	—	Clean	2-8
Clutch			Inspect	Inspect	—	2-8
Carburetor			Inspect	Inspect	—	2-8
Throttle cable clearance			—	Inspect	—	2-9
Fuel hose			Inspect	Inspect	—	2-9
			Replace every 4 years			
Fuel strainer			Inspect	Inspect	—	2-9
Drive chain			Inspect, clean and lubricate every 1 000 km			2-10
Brakes	Brakes		Inspect	Inspect	—	2-11
	Brake fluid hose		Inspect	Inspect	—	
	Brake fluid		Replace every 4 years			
			Change every 2 years.			
Tire			Inspect	Inspect	—	2-14
Steering			Inspect	Inspect	—	2-14
Front and rear absorber			—	Inspect	—	2-14
Lighting and signal			Inspect	Inspect	—	2-15
Chassis bolts and nuts			Inspect	Inspect	—	2-15

LUBRICATION CHART

Item	Interval	Km	Initial and Every 5 000	Every 10 000
	Month		6	12
Throttle cable			Engine oil	—
Throttle grip			—	Grease
Clutch cable			Engine oil	—
Speedometer cable			—	Grease
Speedometer gear box			—	Grease
Tachometer cable			—	Grease
Drive chain			Motor oil, every 1 000 km	
Brake pedal			Grease or motor oil	—
Brake cam shaft			—	Grease
Steering			Grease every 2 years or 20 000 km.	
Swing arm bearings				

WARNING

Be careful not to apply too much grease to the brake cam shafts. If grease gets on the linings, brake slippage will result.

CAUTION

Lubricate exposed parts which are subject to rust, with either motor oil or grease whenever the motorcycle has been operated under wet or rainy conditions. Before lubricating each part, clean off any rusty spots and wipe off any grease, oil dirt or grime.

MAINTENANCE PROCEDURES

This section describes the service procedures for each section of Periodic Maintenance.

BATTERY / FUSE

Inspect Initial 1 000 km and every 5 000 km

BATTERY

- The battery must be removed to check the electrolyte level and specific gravity.
- Remove the right frame cover.
- Remove battery \ominus lead at the battery terminal.
- Remove battery \oplus lead.
- Remove battery from the chassis.
- Check electrolyte for level and specific gravity. Add distilled water, as necessary, to keep the surface of the electrolyte above the LOWER level line ① but not above the UPPER level line ②. For checking specific gravity, use a hydrometer to determine the charged condition. An S.G. reading of 1.28 (20 °C) or under means that the battery needs recharging off the machine: take it off and charge it from a recharger. Charging the battery in place can lead to failure of the regulator/rectifier.

DATA Standard specific gravity: 1.28 ± 0.01 at 20 °C

TOOL 09900-28403 : Hydrometer

- To install the battery, reverse the procedure described above.

CAUTION

When installing the battery lead wires, fix the \oplus lead first and \ominus lead last.

- Make sure that the breather pipe is tightly secured and undamaged, and is routed as shown in the figure.

FUSE

- The fuse locates on the belt of the battery. In case of engine stop suddenly or opened circuit, the fuse must be inspected.

WARNING

Do not use a fuse of a different specification , or it will incur negative effect to electric, fire and power loss of engine which is very dangerous.

Do not use aluminum, iron wire or any other substitute for the fuse. If the fuse blows frequently, it indicates the electric system may has problem. Always investigate the cause, correct it and then replace the fuse.

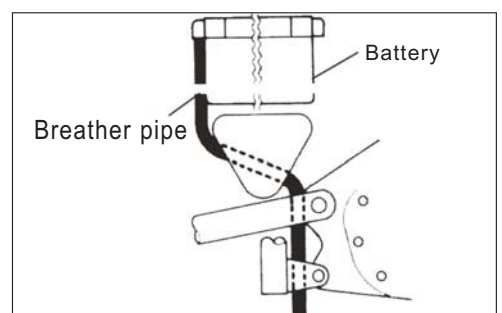
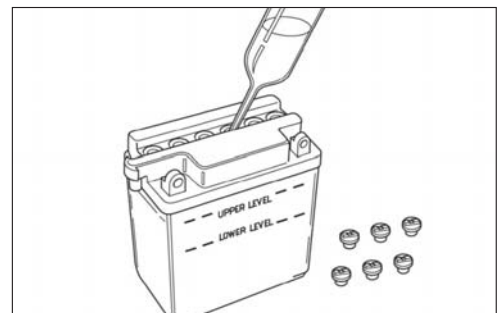
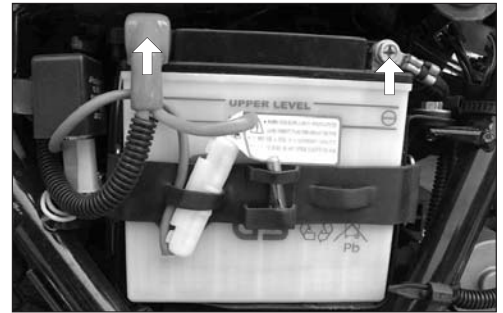

AIR CLEANER

Clean every 3 000 km

If the air filter is clogged with dust, intake resistance will be increased with a resultant decrease in output and an increase in fuel consumption.

Check and clean the element in the following manner.

- Remove the left frame cover.
- Remove the screws and take off the air filter cover.
- Separate the polyurethane foam element from the element frame.

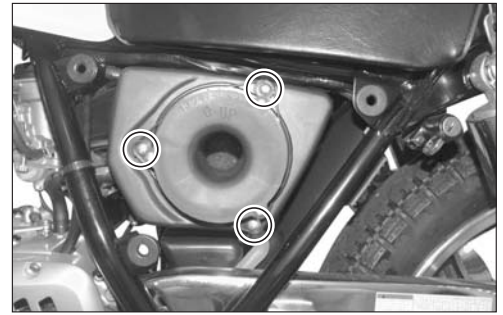

- Fill a washing pan of a proper size with nonflammable cleaning solvent. Immerse the element in the cleaning solvent and wash it.
- Squeeze the cleaning solvent out of the washed element by pressing it between the palms of both hands.
- Immerse the element in motor oil, and squeeze the oil out of the element leaving it slightly wet with oil.

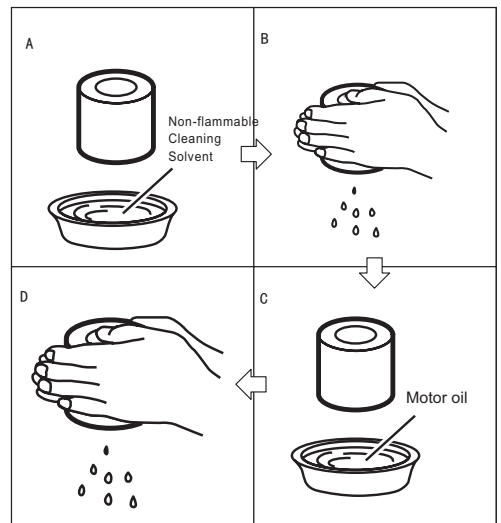

⚠ CAUTION

- Do not twist or wring the element because it will tear or the individual cells of the element will be damaged.
- If driving under dusty condition, clean the air cleaner element more frequently.

- Reassemble the air cleaner in the reverse order of removal.
- Remove the plug and drain water and oil at the periodic maintenance interval.

⚠ CAUTION

- Make sure the drain plug is fitted correctly after cleaning.
- If driving under humidity condition, clean the air cleaner more frequently.

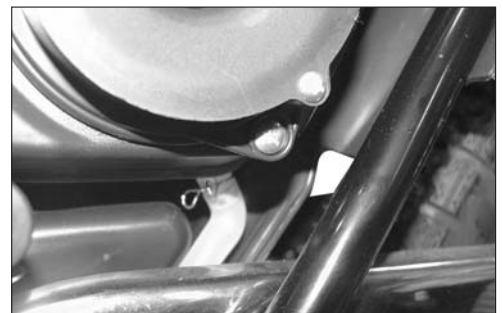

MUFFLER BOLTS

Inspect initial 1 000 km and tighten every 5 000 km

- Tighten the muffler bolts ① to the specified torque.

 Muffler bolt ①: 11~15 N•m

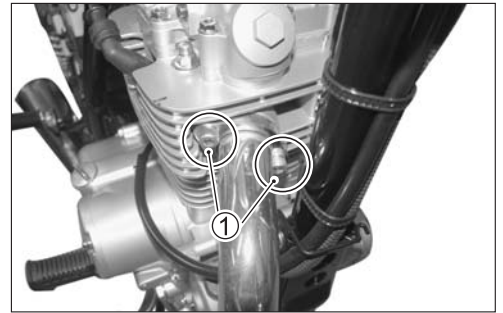

CYLINDER HEAD AND CYLINDER NUTS

Inspect initial 1 000 km and every 5 000 km.

- Tighten four M10 nuts ① to the specified torque when the engine is cold.

 Cylinder head nut: 21~25 N•m

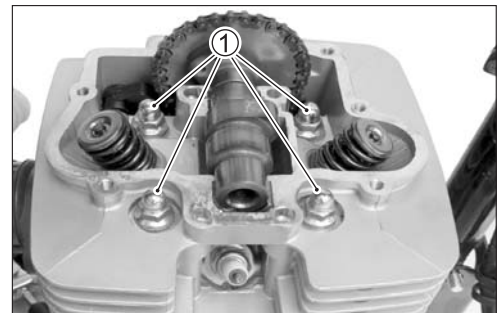

- Tighten the cylinder nut ② and ③ to the specified torque.

 Cylinder nut: 8-12 N•m

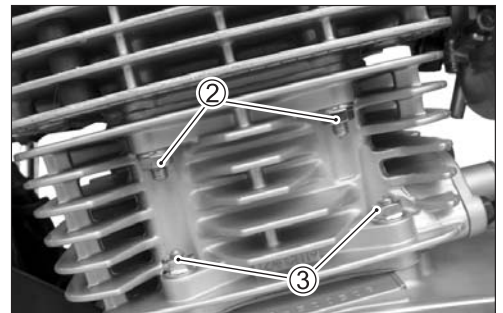

VALVE CLEARANCE

Inspect initial 1 000 km and every 5 000 km

Excessive valve clearance results in valve noise, insufficient valve clearance results in valve damage and reduced power. At the distances indicated above, check and adjust the valve clearance to the following specification.

- Remove the spark plug, valve timing inspection plug ④ and valve inspection caps ⑤.
- Remove the generator cover cap ⑥ and rotate the generator rotor with wrench anticlockwise until the line on the rotor is aligned with the center (arrow mark) of hole on the crankcase to set the piston at TDC for the compression stroke.

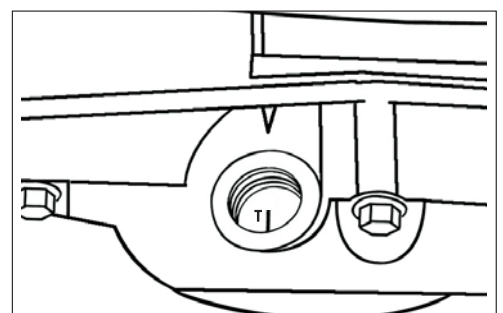
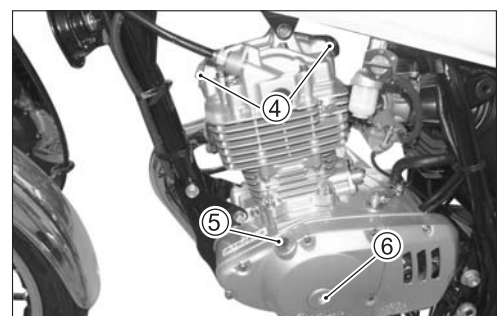

CAUTION

Valve clearance should be checked when the engine is cold. Both the intake and exhaust valve must be checked and adjusted when the piston is at TDC of the compression stroke.

- Hook the valve rocker arm with the special tool, insert the thickness gauge to the valve stem end and the adjusting screw on the rocker arm.

TOOL 09900-20803: Thickness gauge
11F14-017: Valve adjust spring

VALVE CLEARANCE SPECIFICATIONS

DATA Valve clearance (when cold)
IN.: 0.04-0.07 mm EX.: 0.13-0.18 mm

- If the clearance is off the specification, bring it into the specified range by using the special tool.



SPARK PLUG

Inspect initial 1 000 km and every 5 000 km, replace every 10 000 km.

Remove the carbon deposits with a wire of pin and adjust the spark plug gap to 0.7-0.8 mm, measuring with a thickness gauge.

When removing the carbon deposits, be sure to observe the appearance of the plug, noting the color of the carbon deposits. The color observed indicates whether the standard plug is suitable or not. If the standard plug is apt to get wet, a hotter plug should be used. If the standard plug is apt to overheat (porcelain is whitish in appearance), replace with a cooler one.

DATA Spark plug gap: 0.7-0.8 mm

TOOL 09900-20803: Thickness gauge

TYPE	NGK
Hot type	CR7E
Standard	CR8E
Cold type	CR9E

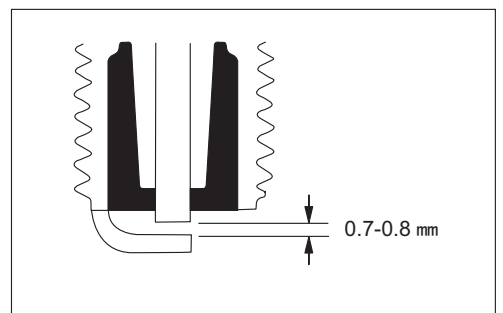
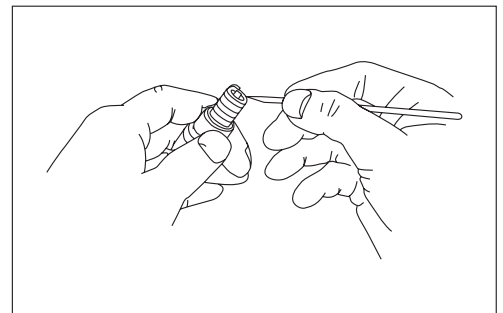

ENGINE OIL

Change initial 1 000 km and every 3 000 km

Engine oil should be changed while the engine is hot.

- Support the motorcycle by the center stand.
- Drain the engine oil by removing the drain plug and filler cap / gauge.
- Tighten the drain plug and pour new engine oil through the oil filler. The engine will hold about 1 000 ml of oil. Use of SF/SG in API with an oil viscosity of SAW 10W-40.

DATA Required amount of engine oil:
Oil change: 850 ml
Oil filter change: 950 ml
Overhaul: 1 300 ml

- Start up the engine and allow it to run for several minutes at idling speed.
- Shut down the engine and wait about two minute. Then check the oil level in the oil level window. The motorcycle must be in a level, upright position for accurate measurement. If the level is below the “F” mark, add oil until the level reaches the “F” mark.

ENGINE OIL FILTER

Clean initial 1 000 km and every 5 000 km

Replace the oil filter in the following manner:

- Drain the engine oil by removing the drain plug.
- Remove the two screws securing the filter cap.
- Take off the cap ①, and pull out the filter ④.
- Replace with the new engine oil filter.
- Before installing on the filter, check to be sure that the O-ring ⑤ is properly installed.
- Before putting on the filter cap ①, make sure that spring ③ and o-rings ② are installed correctly.
- Install the filter cap ① and tighten the screws securely.
- Add the engine oil and inspect the engine oil level.

⚠ CAUTION

When reassembly the oil filter, make sure to check the oil filter installed as shown in illustration.
If the filter is installed improperly, serious engine damage may result.

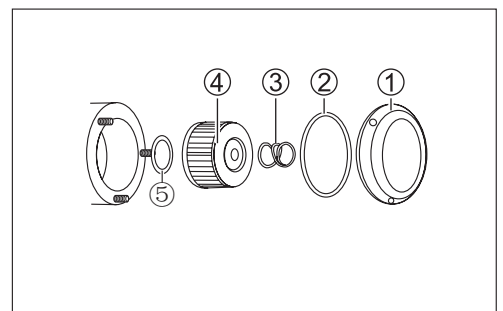
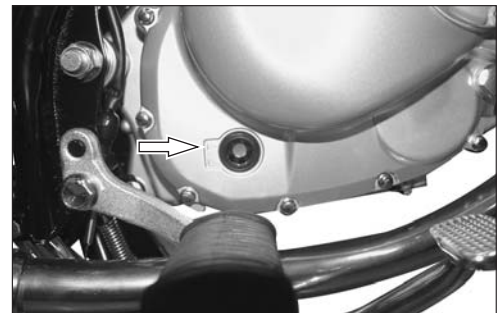
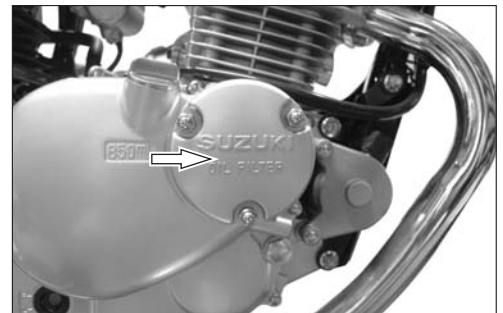
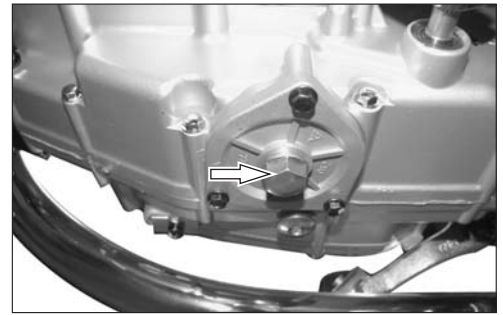

OIL SUMP FILTER

Clean every 10 000 km

Clean the sump filter to remove any foreign matter that may be collected there. Inspect the screen to insure that it is free of any sign of damage.

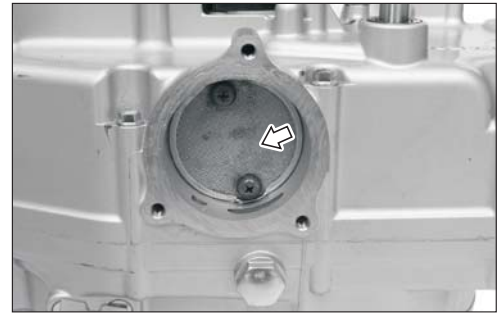

CLUTCH

Inspect initial 1 000 km and every 5 000 km.

The clutch play should be 4 mm as measured at the clutch lever holder before the clutch begins to disengage. If the play in the clutch is incorrect, adjust it in the following way:

- Loosen the lock nut ① and screw the adjuster ② on the clutch lever holder all the way in.
- Loosen clutch cable adjuster lock nut ③.
- Turn the clutch cable adjuster ④ in or out to acquire the specified play.
- Use the adjuster ② for minor adjustment.
- Tighten lock nut while holding the adjuster in position.

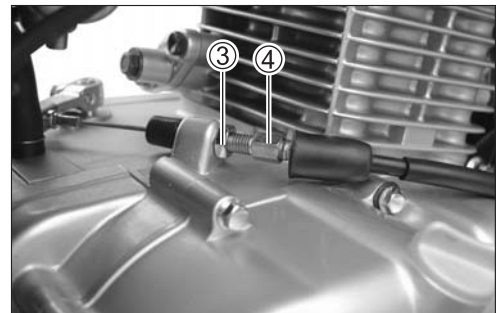
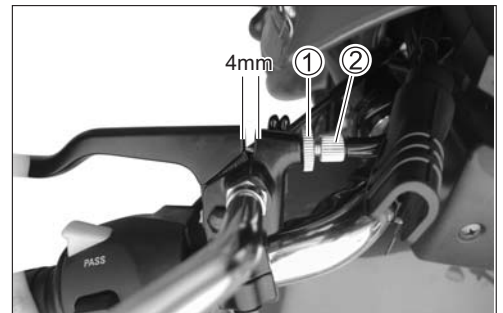

⚠ CAUTION

Excessive clutch cable play makes clutch dragging easily lead to the damage or wear of the clutch and gear shifting mechanism.

CARBURETOR

Inspect initial 1 000 km and every 5 000 km

Stable carburetor performance is the basis requirement for engine. The carburetor is pre-set at the factory for the best carbureting. Do not attempt to alter its setting. There are two items of adjustment, engine idle speed and throttle cable play.

IDLING ADJUSTMENT

- Start up the motorcycle, maintain the low engine speed until the motorcycle is preheated fully.
- After preheating, set its speed at anywhere between 1 400 and 1 600 r/min by turning adjust screw.

DATA Engine idle speed: 1500±100 r/min

⚠ CAUTION

Make this adjustment when the engine is hot.

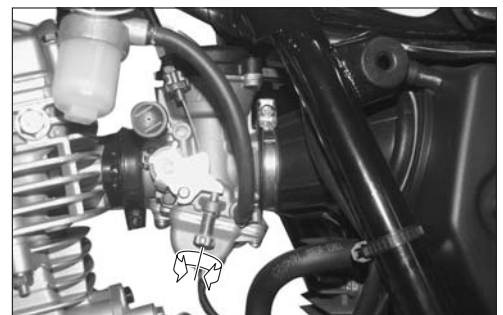

THROTTLE CABLE PLAY

Inspect initial 1 000 km and every 5 000 km

To adjust the throttle cable play to be 0.5-1.0 mm.

- Loosen the locking nut ①, turn the adjuster ② so that the throttle grip has 0.5 -1.0 mm play.
- Tighten the locking nut ①.

⚠ WARNING

After adjustment is completed, checked that handlebar movement does not raise engine idle speed and that the throttle grip returns smoothly and automatically.

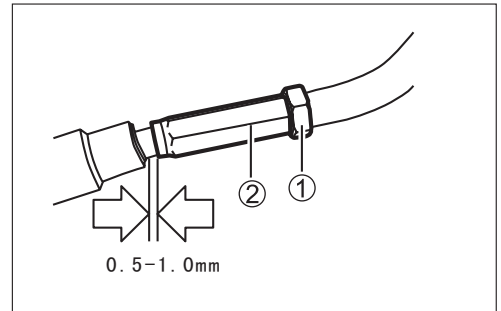

FUEL HOSE

Inspect initial 1 000 km and every 5 000 km. Replace every 4 years.

Inspect the fuel hose ① and connections for damage and fuel leakage. If any defects are found, the fuel hose must be replaced.

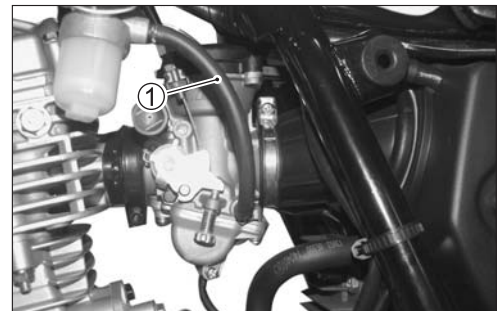

FUEL STRAINER

Clean initial 1 000 km and every 5 000 km.

After fuel strainer removed, the fuel strainer should be thoroughly blown by compressed air from its interior to its exterior.

The fuel strainer should be inspected and cleaned periodically. If the fuel strainer is damaged, replace it immediately.



- Ⓐ Filter bowl
- Ⓑ Fuel filter
- Ⓒ Seal ring

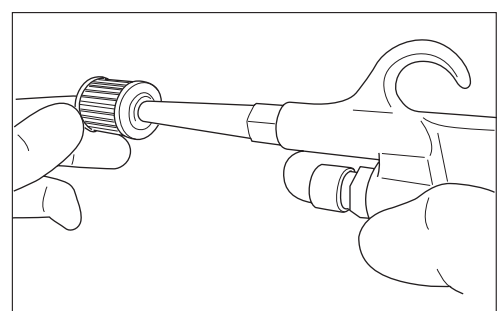
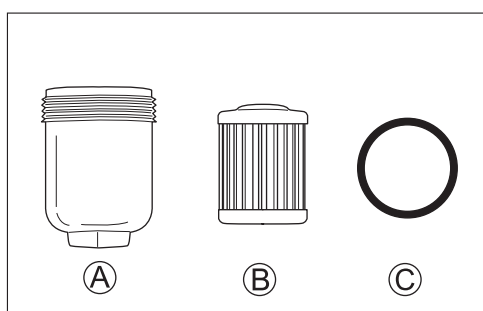

DRIVE CHAIN

Clean and lubricate every 1 000 km

DRIVE CHAIN / SPROCKET

Visually inspect the drive chain for the below listed possible malconditions. (Lift the rear wheel by placing the center stand, and turn the rear wheel slowly by hand with transmission in NEUTRAL.)

- | | |
|-------------------|----------------------------|
| 1. Loose pins | 2. Damage rollers |
| 3. Rusted links | 4. Twisted or seized links |
| 5. Excessive wear | |

If any defects are found, the drive chain must be replaced.

Damage to the drive chain means that the sprockets may also be damaged. Inspect the sprockets for the following:

1. Excessively worn teeth
2. Broken or damaged teeth
3. Loose sprocket mounting nuts

Cleaning and Lubrication

After thoroughly washing the drive chain with detergent liquid and allowing it to dry, lubricate the drive chain with chain lube or new engine oil.

Drive Chain Adjustment

Adjust the drive chain slack to the proper specification. The drive chain may require more frequent adjustment than periodic maintenance schedule depending upon your riding conditions.

⚠ WARNING

Too much chain slack can cause the chain to come off the sprocket, resulting in an accident or serious damage to the motorcycle. Inspect and adjust the drive chain slack before each use.

- Place the motorcycle on center stand.
- Loosen rear axle nut ④.
- Loosen the right and left lock nuts ②.
- Loosen or tighten both chain adjuster bolts ① till there is 10-20mm of slack at the middle of the chain between engine and rear sprockets. The mark ③ on both chain adjusters ⑤ must be at the same position on the scale to ensure that front and rear wheels are correctly aligned.
- After adjusting the drive chain, tighten rear wheel axle nut ④ to the specified torque.
- Check the rear brake pedal travel. (Refer to page 2-14)

🔧 Rear axle nut: 50-80 N•m

CHAIN WEAR

Count out 21 pins on the chain and measure the distance between. If the distance exceeds 259.4 mm, the chain must be replaced.

DATA Drive chain 20 pitch length limit: 259.4 mm

TOOL 09900-20103 : Vernier caliper

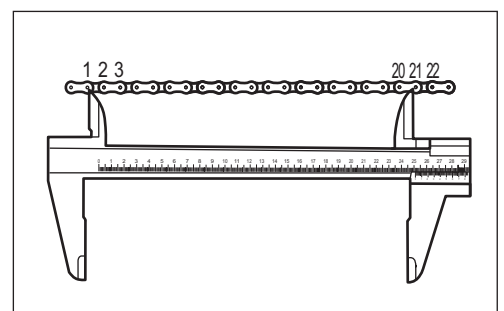
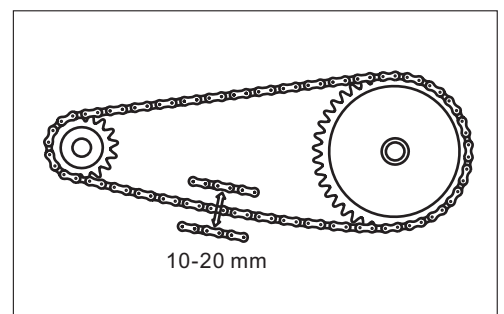
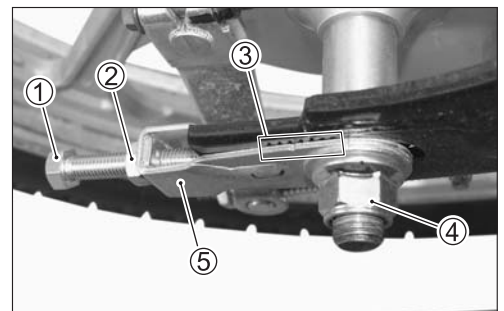
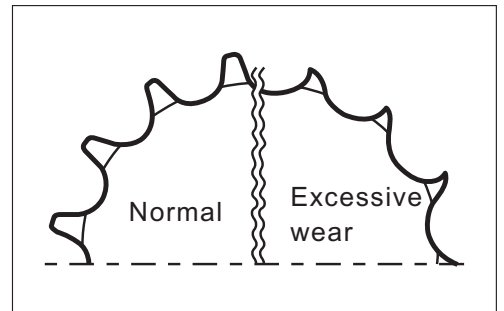
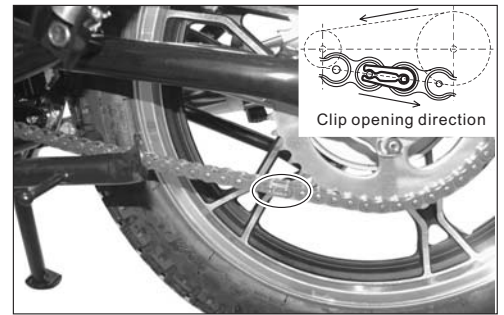

BRAKES

Inspect initially at 1 000 km and every 5 000 km.
 Replace hose every 4 years.
 Change fluid every 2 years.

FRONT BRAKE(DISC TYPE)

Brake fluid level

- Support the motorcycle body on the center stand, and place the handlebars straight.
- Check the brake fluid level by observing the lower level line on the brake fluid reservoir.
- When the level is below the lower level line, replenish with brake fluid that meets the following specification.

 **Specification and classification: DOT 3 or DOT 4**

WARNING

Brake fluid is harmful or fatal if swallowed, and harmful if it comes in contact with skin or eyes. If brake fluid is swallowed, immediately contact a poison control center or a physician. If brake fluid gets in eyes, flush eyes with water and seek medical attention. Do not wash the master cylinder with high pressure water.

CAUTION

The brake system of this motorcycle is filled with a glycol-based brake fluid. Do not use or mix different types of fluid such as silicone-based or petroleum-based. Do not use any brake fluid taken from old, used or unsealed containers. Never re-use brake fluid left over from the last servicing or stored for a long period.

FRONT BRAKE DISC AND FRONT BRAKE PADS

Check the thickness ① of front brake disc, replace the front brake disc with new one if the thickness is less than 3.5mm. The extent of brake pad wear can be checked by observing the grooved limit line ② on the pad. When the wear exceeds the grooved limit line, replace the pads with new ones.

WARNING

Do not drive the motorcycle immediately after the replacement of the new brake disc or brake pads. Squeeze and release the brake lever several times to make the mating of brake disc and brake pads completely and circulation of brake fluid stably. The brake distance is longer than the original distance after the replacement of new brake disc or brake pads. After 300 km of driving, the motorcycle will get the best break performance. Before that, Keeping enough brake distance is necessary during the driving.

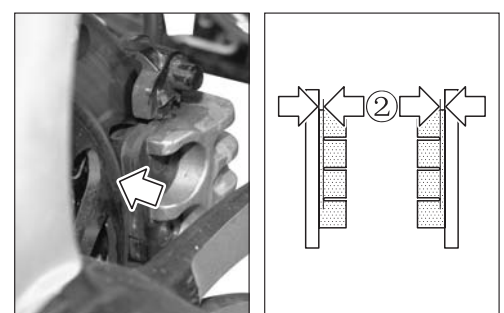
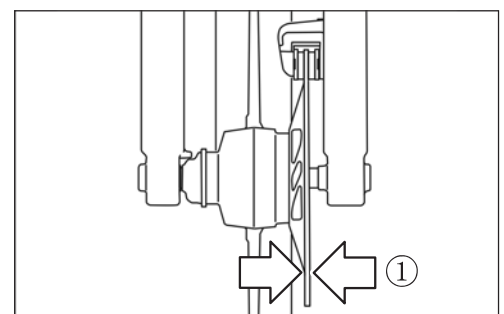
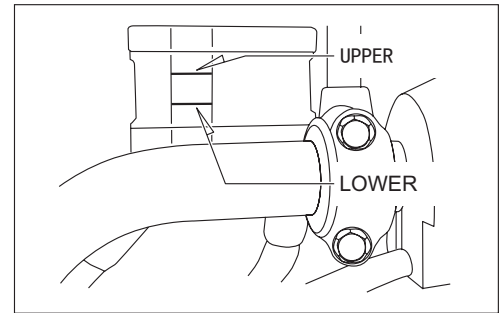

AIR BLEEDING THE BRAKE FLUID CIRCUIT

Air trapped in the fluid circuit acts like a cushion to absorb a large proportion of the pressure developed by the master cylinder and thus interferes with the full braking performance of the caliper brake. The presence of air is indicated by "sponginess" of the brake lever and also by lack of braking force. Considering the danger to which such trapped air exposes the machine and rider, it is essential that, after remounting the brake and restoring the brake system to the normal condition, the brake fluid circuit be purged of air in the following manner:

- Fill up the master cylinder reservoir to the upper line.
Replace the reservoir cap to prevent entry of dirt.
- Attach a pipe to the caliper bleeder valve, and insert the free end of the pipe into a receptacle.
- Squeeze and release the brake lever several times in rapid succession, and squeeze the lever fully without releasing it.
- Loosen the bleeder valve by turning it a quarter of a turn so that the brake fluid runs into the receptacle; this will remove the tension of the brake lever causing it to touch the handlebar grip. Then close the valve, pump and squeeze the lever, and open the valve.
- Repeat this process until the fluid flowing into the receptacle no longer contains air bubbles.

▲ CAUTION

Replenish the brake fluid reservoir as necessary while bleeding the brake system. Make sure that there is always some fluid visible in the reservoir.

- Close the bleeder valve, and disconnect the pipe. Fill the reservoir to the "upper" level line.

▲ CAUTION

Handle the brake fluid with care: the fluid reacts chemically with paint, plastics, rubber materials, etc.

FRONT BRAKE LIGHT SWITCH

Squeeze the front brake lever to inspect the brake light switch. If the brake light switch works inflexible, inspect, adjust or replace.

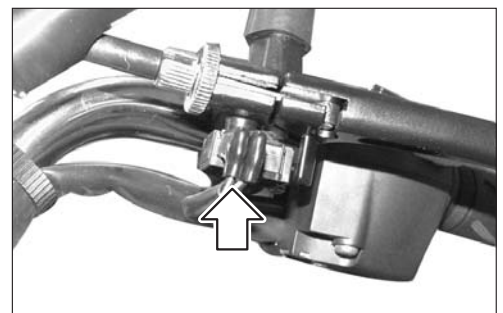
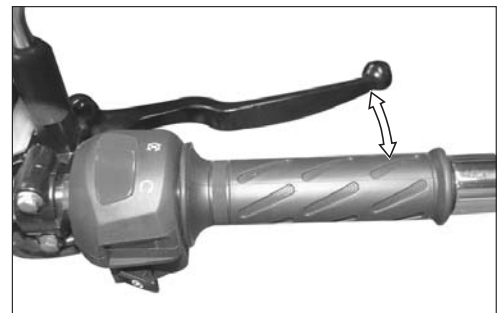
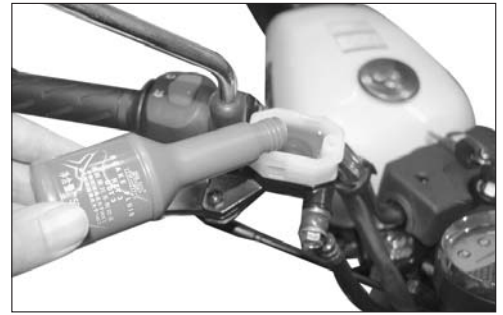

REAR BRAKE

Rear brake pedal height

Adjust the brake pedal limit screw ① to set the brake pedal at the position of 10-20mm higher than the footrest, then tighten the locking nut.

DATA Rear brake pedal height ①: 10-20 mm

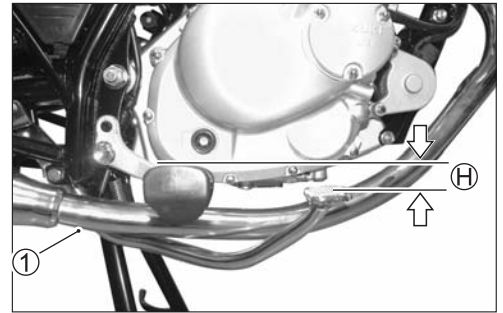

Rear brake pedal travel

Rear brake travel ② is the distance from stepping on the brake pedal until the brake begins taking effect. Turn the rear brake adjuster ③ to adjust the travel ② to 20-30 mm.

DATA Brake pedal travel ②: 15~25 mm

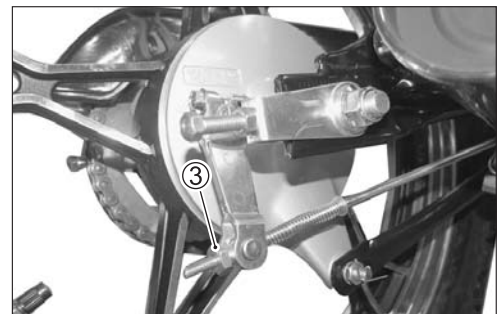
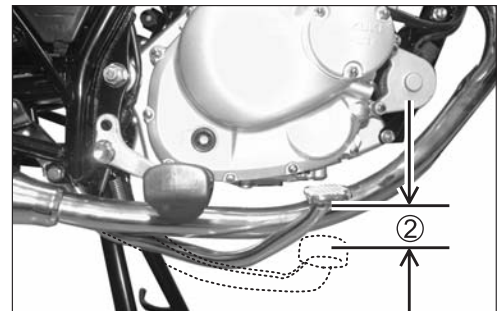

REAR BRAKE LINING WEAR LIMIT

The motorcycle is equipped with brake lining wear limit indicator on rear brakes. To check wear of the brake lining, follow the steps below.

- Check if the brake system is properly adjusted first.
- While operating the brake, check to see the extension line ① from the index mark ② is within the range on the brake panel.
- If the index mark is outside the range as shown in the illustration at right, the brake shoes should be replaced to ensure safe operation.

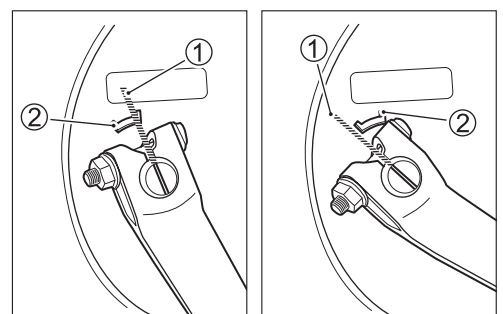

REAR BRAKE LIGHT SWITCH

Adjust rear brake light switch so that brake light will come on just before a pressure is felt when the brake pedal is stepped.

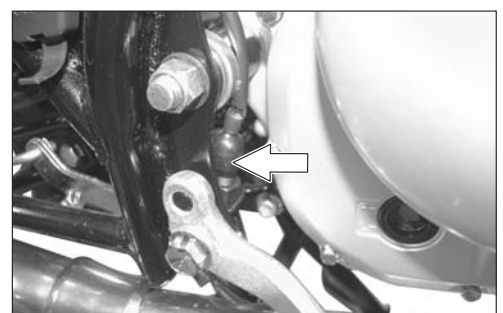

TIRES

Inspect initial 1 000 km and every 5 000 km

Check the tire pressure and surface during the maintenance. There are serial marks ① T.W.I. (Tire Wear Indicator) in the edge of the tire. Check the block ② of T.W.I. in the tread near the mark. If the tire wears off to reach the boss, the tire should be replaced.

Check the damage ③ (punctures or fractures) on the tire surface visually. As surface damage may impede driving stability, such tires should be replaced.

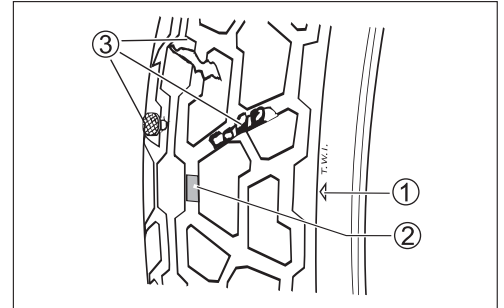

TIRE PRESSURE

COLD INFLATON TIRE PRESSURE	SOLO RIDING		DUAL RIDING	
	Kpa	kg/cm ²	kpa	Kg/cm ²
FRONT	175	1.75	175	1.75
REAR	200	2.00	225	2.25

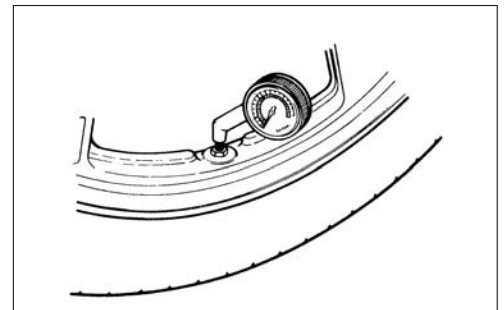

⚠ CAUTION

Proper tire pressure and condition affect vehicle performance. Please check the tire pressure and surface condition periodically.

STEERING

Inspect initial 1 000 Km and every 5 000 Km

Steering stem bearings should be adjusted properly for smooth turning of the handlebars and safe running.

Steering which is too stiff prevents smooth movement of handlebar.

Steering which is too loose will cause vibration and damage to the steering bearing. Check to see that there is no play in the front fork attachment.

If the play is found, perform the steering bearing adjustment as described in page 5-16 of this manual.

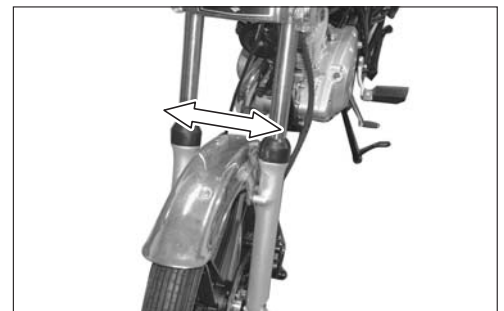

FRONT AND REAR ABSORBER

Inspect every 5 000 km.

FRONT ABSORBER

- Grasp the front brake, squeeze the front absorber to check it's motion.
- Check for leaks or damage. Replace damaged parts and tighten all bolts and nuts.



REAR ABSORBER

- Press the rear carrier, move the rear absorber up and down four or five times to check for the noise or smooth movement.
- Inspect the rear absorber spring for damage, deformation or oil leakage.

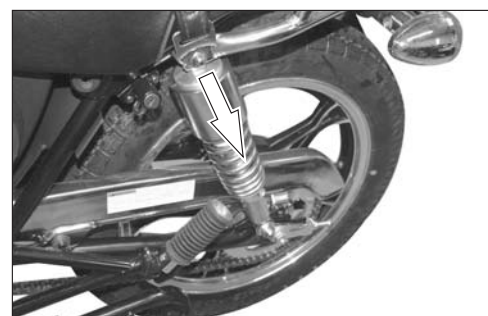

LIGHTING AND SIGNAL

Inspect initial 1 000 km and every 5 000 km

Inspect the headlight, left and right turn signal light, tail light / brake light and dashboard signal light, replace the light if there is something unusual. (Refer to page 6-7)

CHASSIS AND ENGINE MOUNTING BOLTS AND NUTS

Inspect initial 1 000 km and every 5 000 km

The nuts and bolts listed are important parts, and they must be in good condition for safety. They must be re-tightened, as necessary, to the specified torque with a torque wrench.

ITEM		N•m	Kg•m
1	Front axle nut	36-52	3.6-5.2
2	Front brake caliper mounting bolts	18-28	1.8-2.8
3	Brake hose union bolt	20-25	2.0-2.5
4	Front brake disc mounting bolts	18-28	1.8-2.8
5	Front absorber cap bolts	35-55	3.5-5.5
6	Handlebar clamping bolts	12-20	1.2-2.0
7	Steering bolt	35-55	3.5-5.5
8	Lower bracket bolts (front absorber clamp bolts)	25-35	2.5-3.5
9	Rear absorber fitting nuts	22-35	2.2-3.5
10	Rear axle nut	50-80	5.0-8.0
11	Rear brake cam lever bolt	6-8	0.6-0.8
12	Rear torque link bolts	10-16	1.0-1.6
13	Engine mounting bolts	33-39	3.3-3.9
14	Engine hanging nuts	22-33	2.2-3.3
15	Rear swing arm shaft nut	50-80	5.0-8.0
16	Exhaust pipe bolt	11-15	1.1-1.5

PERIODIC MAINTENANCE

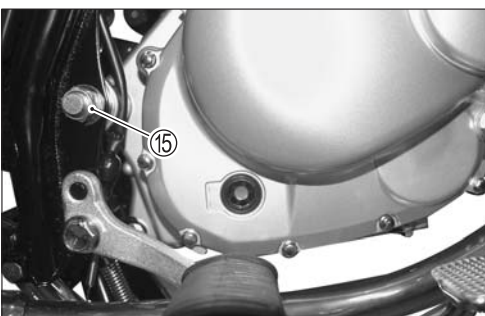
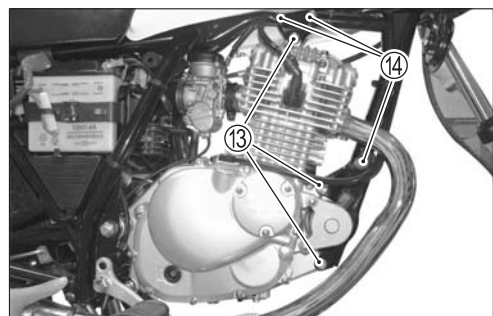
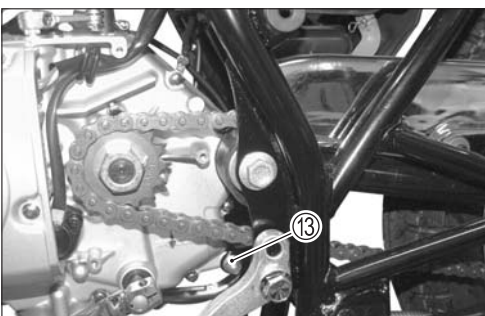
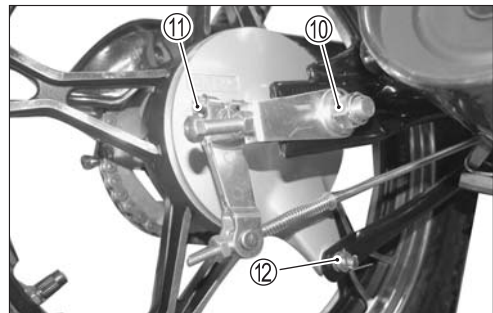
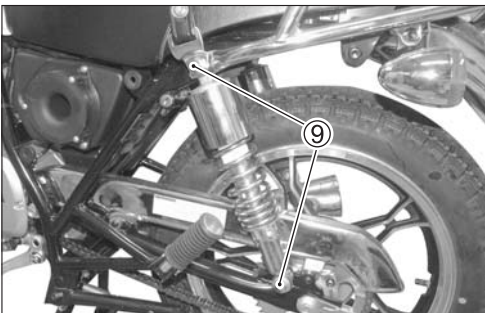
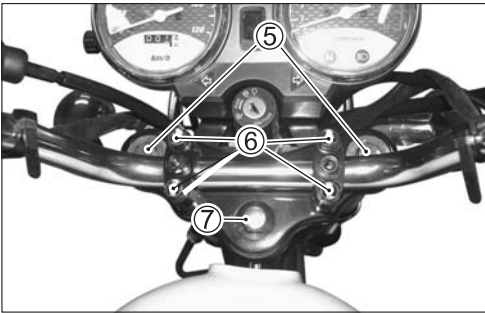
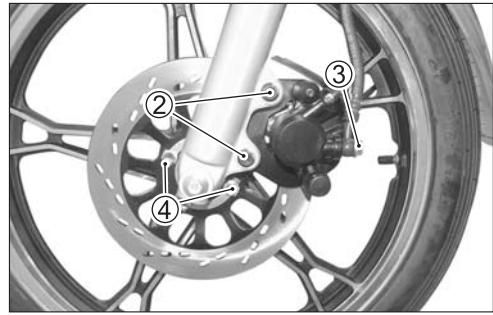
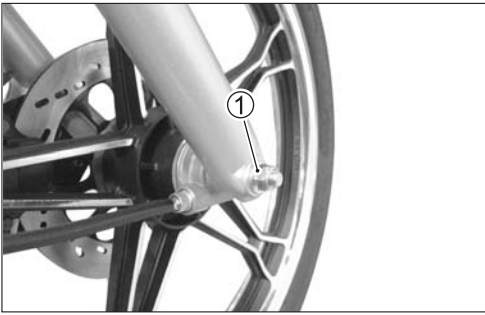

COMPRESSION PRESSURE

Inspect initial 1 000 km and every 5 000 km

Cylinder compression is an indicator of its inner state. The necessity of repair depends on the result of inspection. The record of your authorized maintenance dealer should include compression pressure readings obtained in every maintenance.

NOTE:

- * Before testing the engine for compression pressure, make sure that the cylinder head nuts and bolts are tightened to specified torque values and valves clearance are properly adjusted.
- * Have the engine warmed up by idling before testing it.
- * Ensure that the battery is fully charged.

Remove related parts and inspect compression pressure in the following process:

- Support the motorcycle with the main stand;
- Remove spark plug;
- Fit pressure gauge① and adapter ② to the spark plug hole, pay attention to connector tightening;
- Turn throttle to full opening;
- Electrically start the motorcycle, take the maximum reading in the recording as cylinder compression pressure.

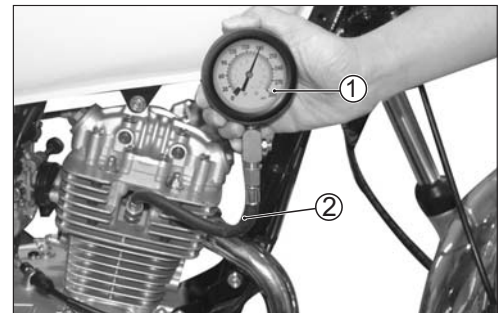

①	Compression gauge	09915-64512
②	Adapter	09915-63310

Compression pressure

Standard	Limit
10-14 kg/cm ²	8 kg/cm ²

A low compression pressure may indicate any of the following malfunctions:

- Excessively worn cylinder wall.
- Worn piston or piston rings.
- Piston rings stuck in the grooves.
- Poor seating contact of valves.
- Defective cylinder head gasket.

When the compression pressure noted is down to or below the limit indicated above, the engine must be disassembled, inspected and repaired as required.

OIL PRESSURE

Inspect every 5 000 km

Periodically inspect oil pressure of engine so as to ascertain the state of moving parts.

Oil pressure inspection procedure

- Support the motorcycle with the main stand;
- Install the oil pressure gauge in the position shown in the illustration.
- Warm up the engine as follows.
 - Summer: approx. 10 min. at 2 000 r/min.
 - Winter: approx. 20 min. at 2 000 r/min.
- After the warming up operation, increase the engine speed to 3 000 r/min, and read the oil pressure gauge

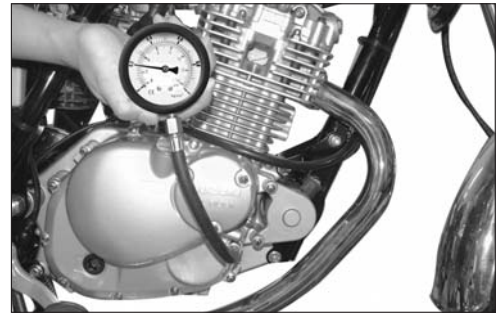

Oil pressure gauge	09915-74510
--------------------	-------------

Oil pressure specification

<p>Above 10 kPa (0.1kg/cm²) Below 30 kPa (0.3kg/cm²)</p>	<p>at 3,000rpm, Oil temperature 60 °C</p>
---	--

A low oil pressure may indicate any of the following malfunctions:

- Engine strainer clogging
- Oil leakage at oil hole
- O-ring damage
- Engine oil pump damage
- Any concurrence of the above

A high oil pressure may indicate any of the following malfunctions:

- Excessive viscosity of engine oil
- Oil hole clogging
- Any concurrence of the above

ENGINE

CONTENTS

REMOVABLE ENGINE PARTS WITH ENGINE IN PLACE	3-1
ENGINE REMOVAL AND REMOUNTING	3-2
CYLINDER HEAD AND VALVE	3-6
CYLINDER AND PISTON	3-17
CLUTCH	3-21
OIL PUMP	3-25
GEAR SHIFTING SHAFT	3-26
GENERATOR AND STARTING CLUTCH.....	3-27
CRANKSHAFT, TRANSMISSION AND KICK STARTER DEVICE	3-31

REMOVING ENGINE PARTS WITH ENGINE IN PLACE

UPPER SIDE OF ENGINE

Chain tensioner	3-6
Cylinder head cover	3-6
Cam shaft	3-7
Cylinder head	3-7
Cylinder	3-17
Piston.....	3-17

RIGHT SIDE OF ENGINE

Oil filter	3-21
Clutch cover.....	3-21
Clutch	3-22
Oil pump	3-25
Gear shifting shaft	3-26

LEFT SIDE OF ENGINE

Sprocket cover.....	3-27
Starting motor.....	3-27
Generator rotor	3-27
Starting clutch	3-28
Generator stator.....	3-28
Trigger coil.....	3-28

ENGINE REMOVAL AND INSTALLATION

ENGINE REMOVAL

Before taking the engine out of the frame, wash the engine with a suitable cleaner. The procedure of engine removal is sequentially explained in the following steps:

- Support the motorcycle with main stand.
- Drain the engine oil.
- Remove the left and right seat mounting bolts and left rear shock absorber nut, then take off the seat.
- Remove the left and right side cover.
- Remove the battery ⊖ lead.

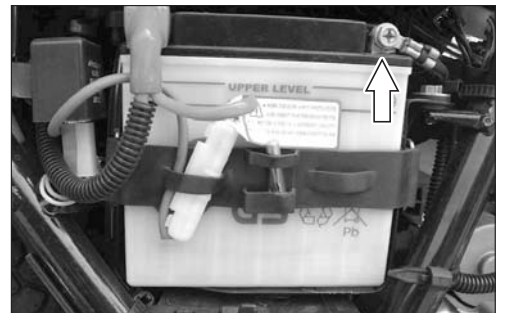

- Turn off the fuel switch, remove the fuel hose.

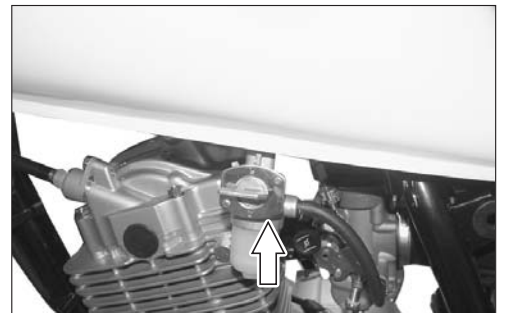

- Disconnect the fuel gauge coupler.
- Take off the fuel tank by removing the mounting bolts ①.

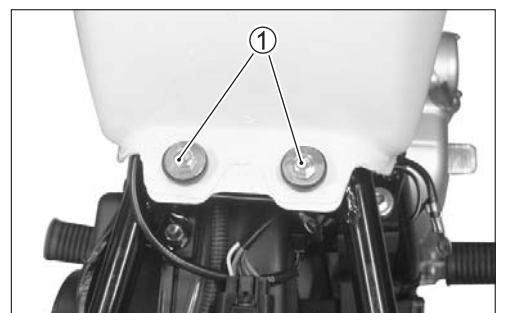

- Take off the clutch cable by removing the clutch lever bolt ② and adjuster lock nut ③.

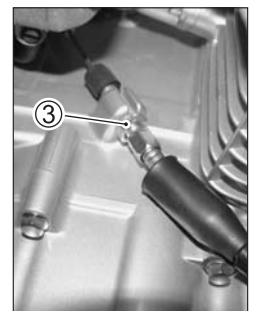

ENGINE

- Remove the generator and gear indication light coupler ⑤ and ⑥.

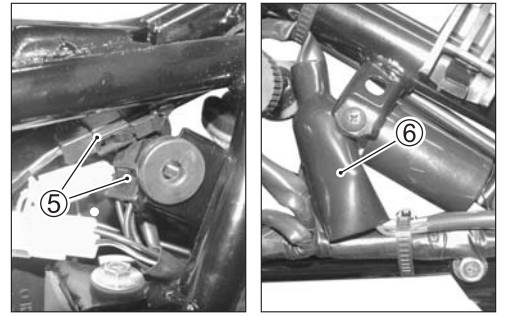

- Disconnect the carburetor balancer pipe ⑦ by unscrewing the clamp screws.

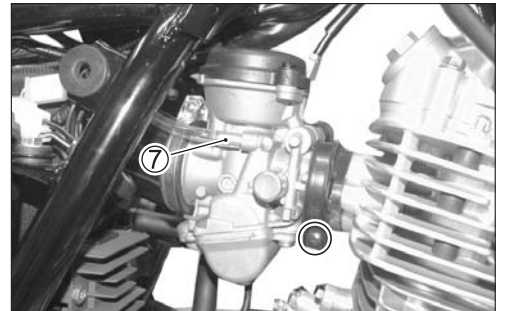

- Loosen the throttle cable adjuster lock nuts, and take off the throttle cable ⑧.

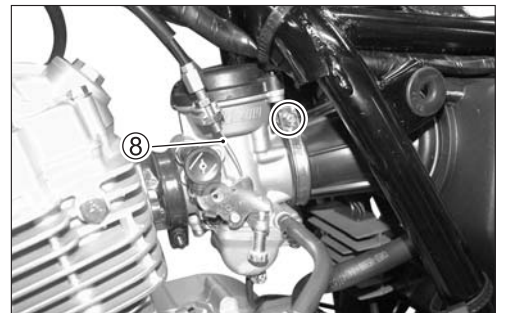

- Remove the crankcase breather pipe ⑨.
- Remove the speedometer cable mounting screw, take off the speedometer cable assembly ⑩.

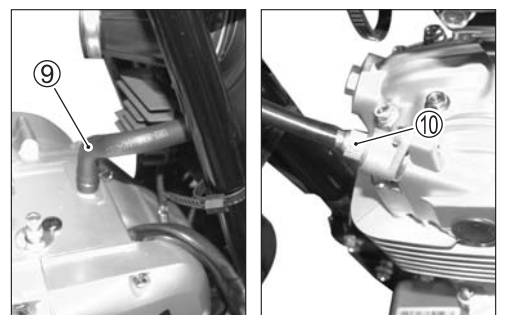

- Take off the engine sprocket cover ⑪.
- Disconnect the ground wire ⑫ from the crankcase.
- Take off the drive chain by removing the clip ⑬.

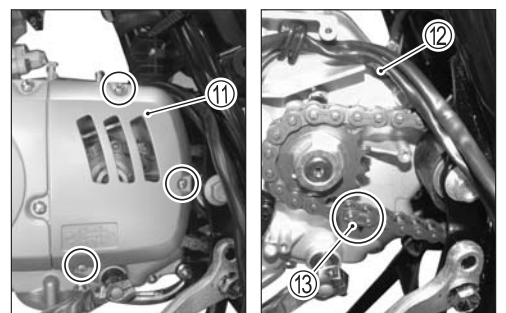

ENGINE

- Remove the lead wire ⑭ of starter motor wire.
- Take off the spark plug cap ⑮.

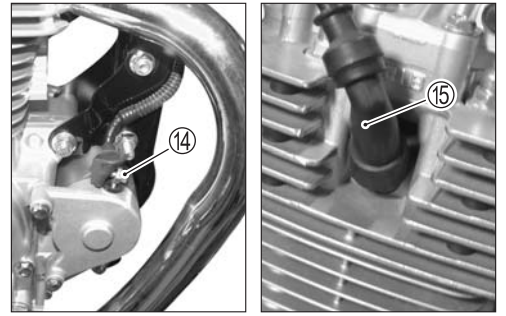

- Remove the muffler mounting bolt ⑯.

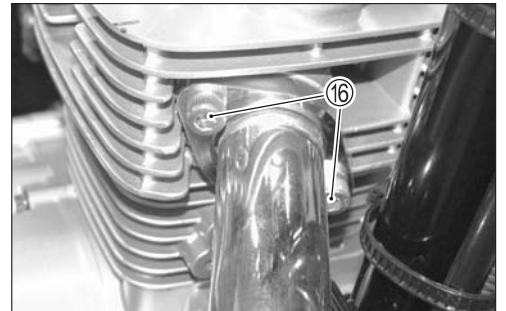

- Remove the muffler mounting bolts ⑰, then take off the muffler.



- Remove the engine front mounting bolt ⑱ and engine lower hanging plate bolt ⑲, take off the engine lower hanging plate.
- Remove the engine upper mounting bolt ⑳ and rear lower mounting bolt ㉑.
- Remove the rear swing arm shaft nut ㉒, draw out the rear swing arm shaft, take out the engine from the right side.

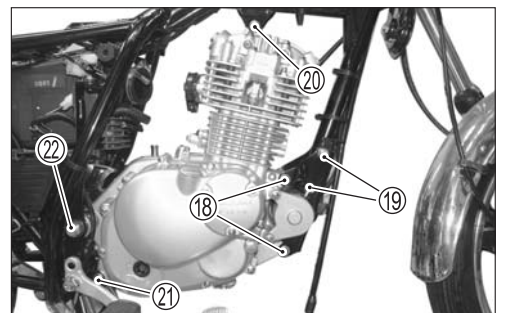

⚠ CAUTION

The engine must be taken out from the right side.

⚠ CAUTION

Be careful not to draw out the swing arm pivot shaft completely from the left side swing arm pivot hole. Insert the shaft or rod into the right side pivot hole from the right side of the frame to keep the alignment of the frame holes and swing arm pivot holes.

ENGINE REMOUNTING

The engine can be mounted in the reverse order of removal.

- Temporarily fasten the engine mounting bracket before inserting the engine mounting bolts.

NOTE:

The engine mounting nuts are self-lock nuts. Once the nut has been removed, it is no longer of any use. Be sure to use new nuts and tighten them to the specified torque.

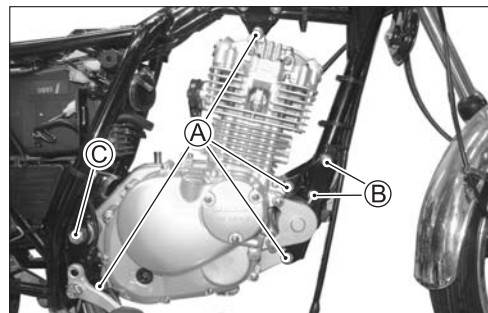

Tightening torque for engine mounting bolts:

-  Engine mounting nut **A** : 33-39 N•m
- Engine lower hanging nut **B** : 22-33 N•m
- Swing arm nut **C** : 50-80 N•m
- Muffler bolt **D** : 11-15 N•m

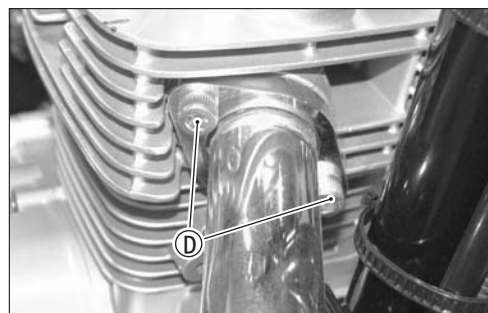

- Install the drive chain and drive chain clip **1**.

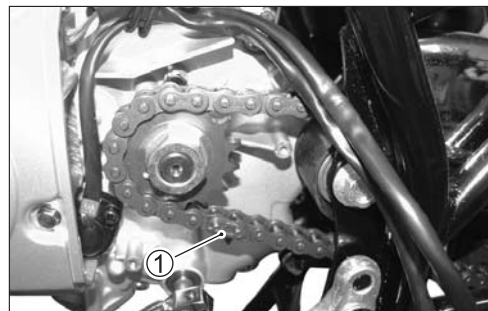

- Align the release arm slit surface with the notch mark on the release cam shaft.

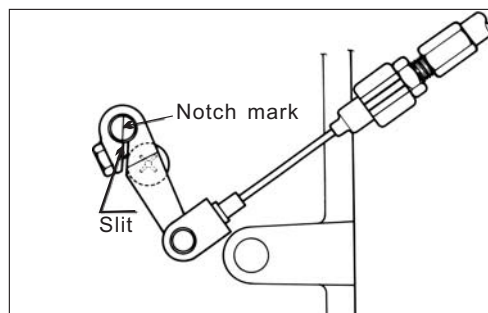

- After installing the engine, pour the engine oil into the engine. (Refer to page 2-7)
- Inspect the oil level. (Refer to page 2-7)
- Inspect the throttle cable (page 2-9)
- Inspect the clutch cable (page 2-8)
- Inspect the idling speed (page 2-8)
- Inspect the drive chain (page 2-10)

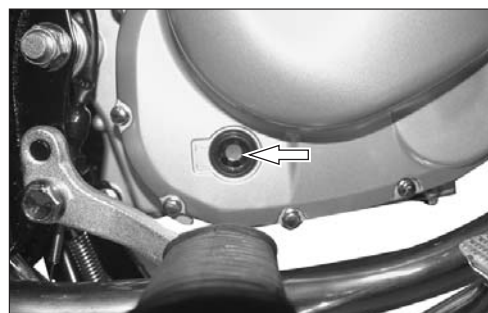

CYLINDER HEAD AND VALVE

REMOVAL

- Drain the engine oil, take off the engine. (Refer to page 3-2)
- Remove the generator cover cap ① and valve timing inspecting plug ②.

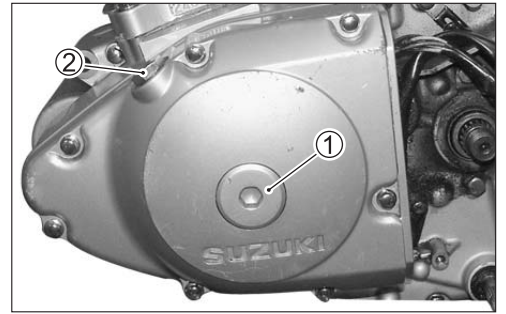

- Remove the valve inspecting caps ③.

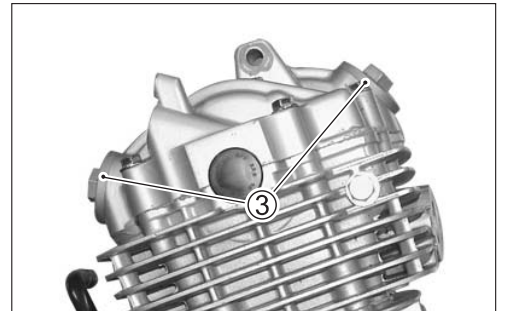

- Bring the piston to top dead center.

▲ CAUTION

When removing cylinder head cover, piston must be at top dead center on compression stroke.

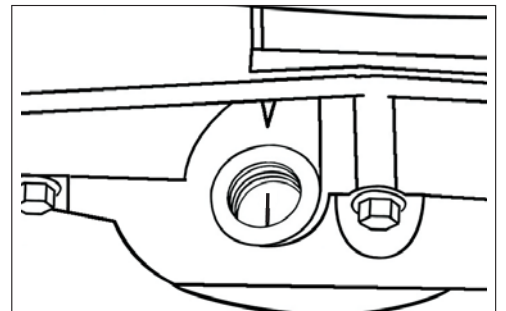

- Remove the camshaft chain tensioner ④.

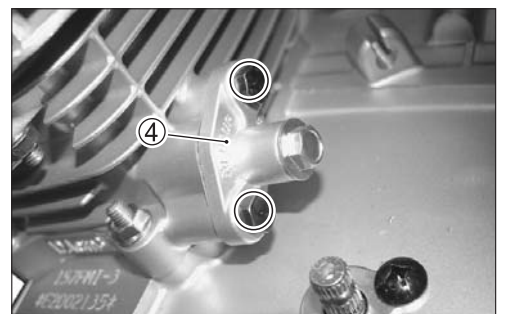

- Loosen the cylinder head cover bolts diagonally.
- Remove the cylinder head cover.

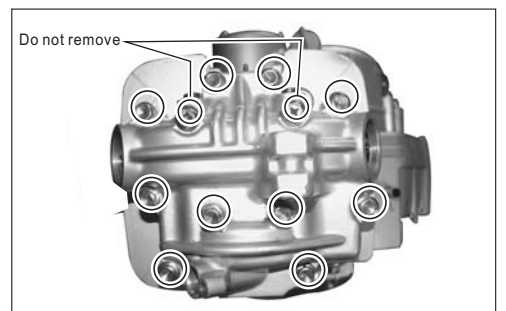

ENGINE

- Remove the camshaft sprocket bolts and detach the camshaft.

⚠ CAUTION

The cam chain tensioner bolt (A) is to be removed only when disassembling the engine.

⚠ CAUTION

Do not drop camshaft drive chain, pin and sprocket into the crankcase.

- Remove the cylinder head side nuts and cylinder side nuts.

- Loosen the cylinder head cover nuts diagonally, then detach the cylinder head.

⚠ CAUTION

If it is difficult to remove the cylinder head, gently pry it off while tapping the finless portion of the cylinder head with a plastic hammer. Be careful not to break the fins.

DISASSEMBLY

- Remove the rocker arm shaft set bolts.
- Pull out the rocker arm shafts with pliers, remove the spring and spring washer.

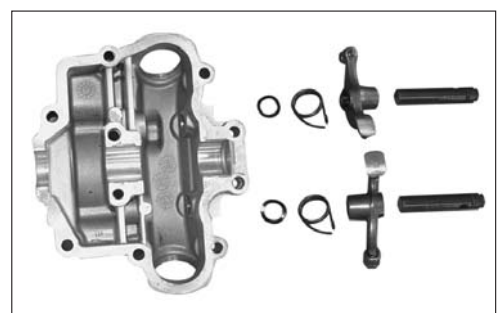
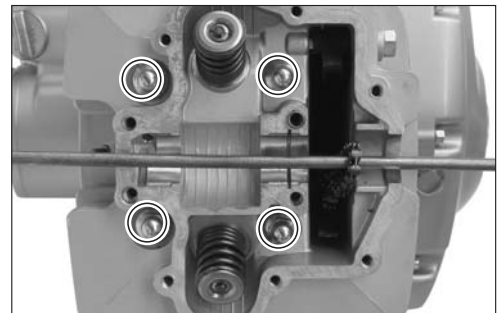
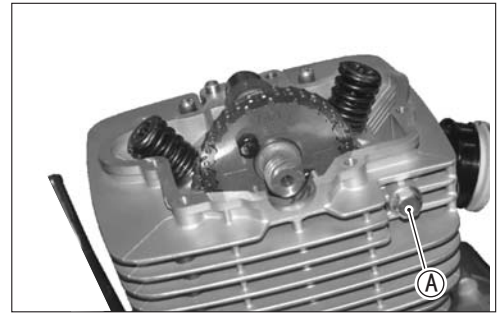

- Take off the valve cotters from the valve stem.

TOOL 11F14-018: Valve spring tools

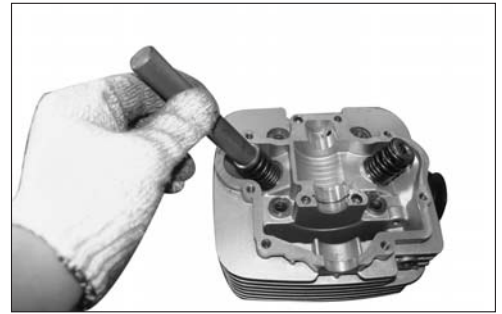

- Take out the valve spring retainers, inner springs and outer springs.
- Pull out the valves from the other side.

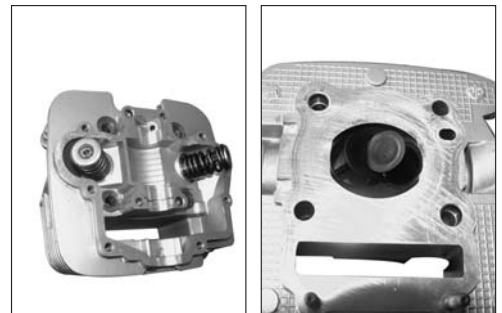

- Remove the oil seal.

CAUTION

Removed oil seal should be replaced with a new one.

- Remove the spring lower retainer.

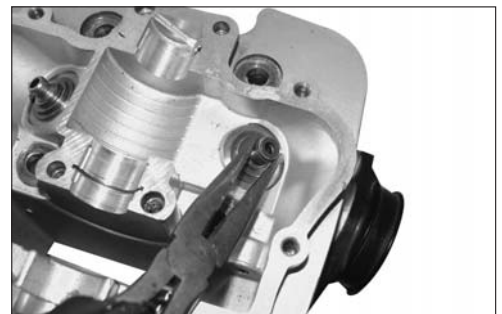

INSPECTION CYLINDER HEAD COVER

After removed the sealant from the fitting surface of the cylinder head cover, place the cylinder head cover on a plain plate and check for distortion with a thickness gauge. Check points are shown in Fig. If the distortion exceeds the limit, replace the cylinder head cover.

DATA Cylinder head distortion limit: 0.05 mm

TOOL 09900-20803: Thickness gauge

ROCKER ARM SHAFT

Measure the diameter of rocker arm shaft.

DATA Rocker arm shaft O.D. (IN and EX): 11.977-11.995 mm

TOOL 09900-20205 : Micrometer (0-25 mm)

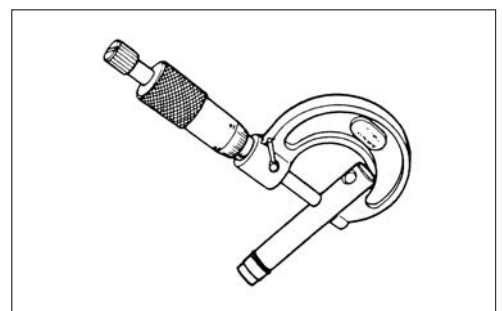
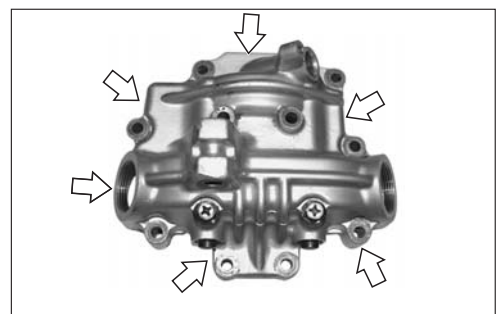

ROCKER ARM

Check the inside diameter of the valve rocker arm and wear of the camshaft contacting surface.

DATA Rocker arm shaft O.D. (IN and EX): 12.0-12.018 mm

TOOL 09900-20605: Caliper gauge

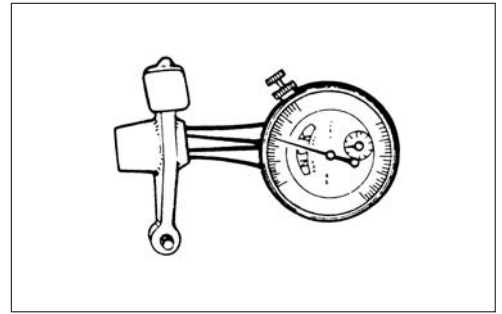

CAMSHAFT

The camshaft should be checked for runout and also for wear of cams and journals if the engine has been noted to produce abnormal noise or vibration or a lack of output power.

Worn-down cams are often the cause of mistimed valve operation resulting in reduced output power. The limit of cam wear is specified for both intake and exhaust cams in terms of cam height H , which is to be measured with a micrometer. Replace camshafts if found it worn down to the limit.

DATA Cam height H limit: IN.: 33.35mm EX.: 33.0 mm

TOOL 09900-20202: Micrometer (25-50 mm)

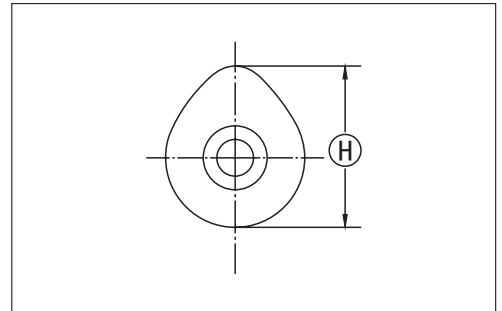

CAMSHAFT JOURNAL WEAR

- Determine whether each journal is worn down to the limit or not by measuring camshaft journal oil clearance with the camshaft installed.
- Use the plastigage to read the clearance at the widest portion, install the cylinder head cover and tighten the cylinder head cover bolts to the specified torque.
- Remove the cylinder head cover and measure the width of the compressed plastigage using the envelope scale. This measurement should be taken at the widest part of the compressed plastigage.

DATA Camshaft journal oil clearance limit: 0.15 mm

TOOL 09900-22302: Plastigage (0.051 – 0.152 mm)

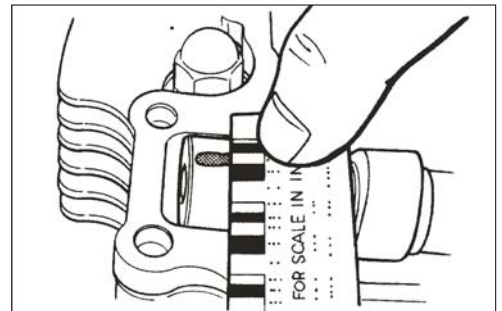

- If the camshaft journal oil clearance measured exceeds the limit, measure the outside diameter of camshaft.
- Replace either the cylinder head set or the camshaft if the clearance is incorrect.

DATA Camshaft journal O.D.: 21.970-21.991 mm

TOOL 09900-20205: Micrometer (0-25 mm)



- Measure the runout with a dial gauge. Replace the camshaft if the runout exceeds the limit.

DATA Camshaft runout limit: 0.1 mm

TOOL 09900-20606: Dial gauge (1/100 mm)
 09900-20701: Magnetic stand
 09900-21304: V-block (100 mm)

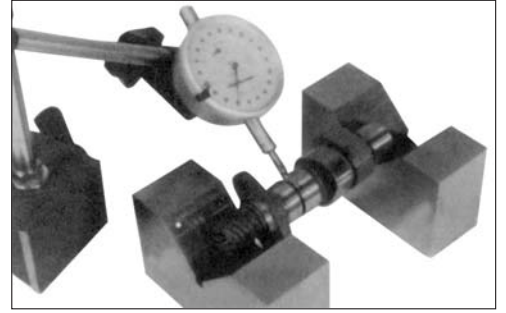

VALVE SPRING

- Measure the valve spring free length.

DATA Valve spring free length limit:
 IN.: 31.24 mm EX.: 33.58 mm

TOOL 09900-20103: Vernier calipers

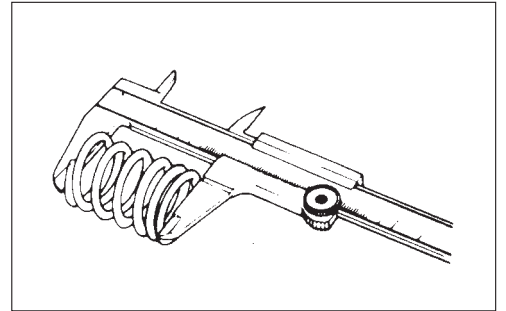

CYLINDER HEAD

- Check the spark plug hole and valve of combustion chamber part for scratch.
- Check the gasketed surface of the cylinder head for distortion with a straightedge and thickness gauge.

DATA Cylinder head distortion limit: 0.05 mm

TOOL 09900-20803: Thickness gauge

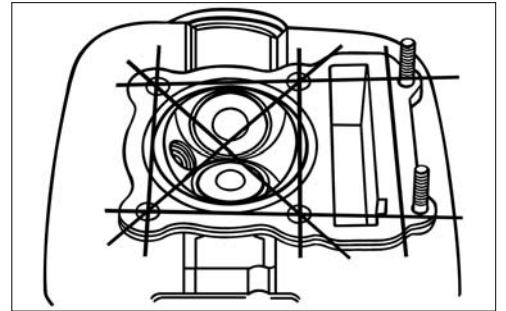

VALVE STEM

- Check the valve stem for bending, pitting or abnormal wear.
- Measure the valve stem O.D.

DATA Valve stem O.D.:
 IN.: 4.975-4.99 mm EX.: 4.955-4.97 mm

TOOL 09900-20205 : Micrometer (0~25 mm)

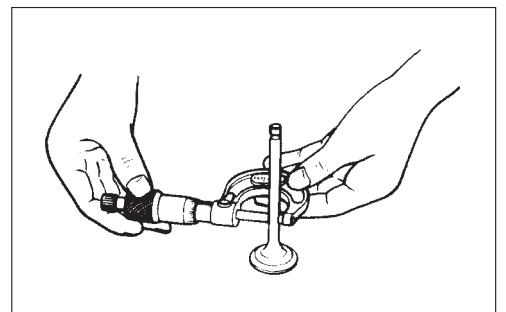

- Measure the thickness (A), and if the thickness is found to have been reduced to the limit, replace the valve.

DATA Valve face thickness limit: 0.5 mm

CAUTION

Visually inspect each valve for wear of its seating face. Replace any valve with an abnormally worn face.

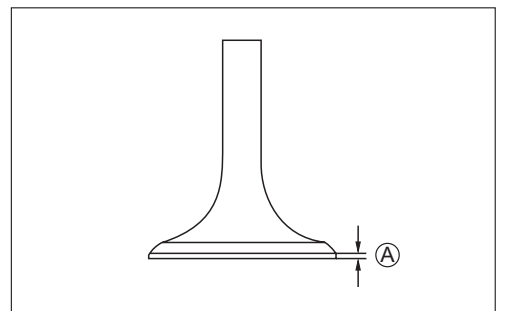

- Support the valve with “V” blocks as shown, and check its runout with a dial gauge. The valve must be replaced if the runout exceeds the limit.

DATA Valve stem runout limit: 0.05 mm

TOOL 09900-20606: Dial gauge (1/100 mm)
 09900-20701: Magnetic stand
 09900-21304: V-block (100 mm)

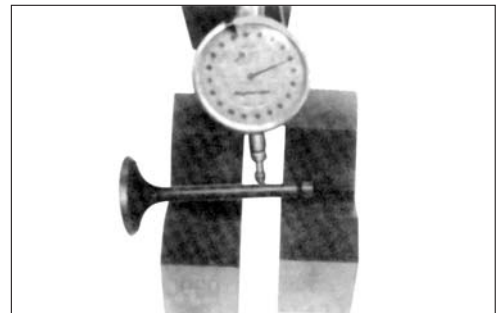

- Place the dial gauge at right angles to the valve head, and measure the valve head radial runout. If it measures more the limit, replace the valve .

DATA Valve stem runout limit: 0.03 mm

TOOL 09900-20606: Dial gauge (1/100 mm)
 09900-20701: Magnetic stand
 09900-21304: V-block (100 mm)

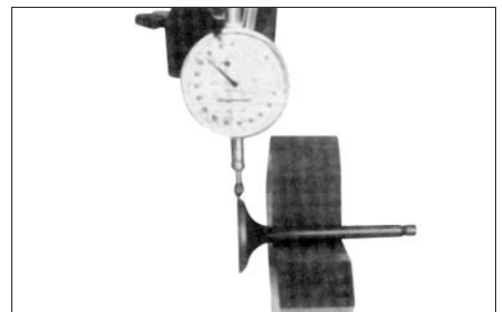

VALVE SEAT INSPECTION AND SERVICING

- Thoroughly clean the the carbon deposits on the valves and valve seat.
- Coat the valve seat with Prussian Blue uniformly.
- Hold the valve with valve lapper, fit the valve and tap the coated seat with the valve face in a rotating manner in order to obtain a clear impression contact.

TOOL 09916-10911: Valve lapper set

The ring-like dye impression left on the valve face must be continuous without any break.

The impression contact can be used to check the contact surface institute, the contact position.

In addition, the width of the dye ring, which is the visualized seat "width", must be within the specification.

If any requirement is not met, correct the valve seat by servicing it as follow steps.

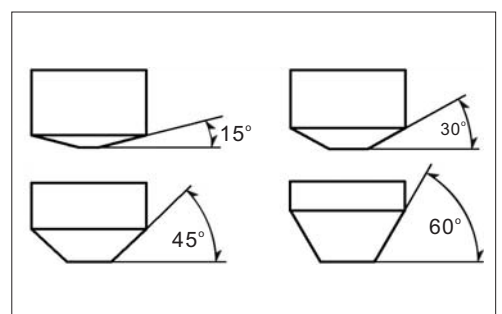
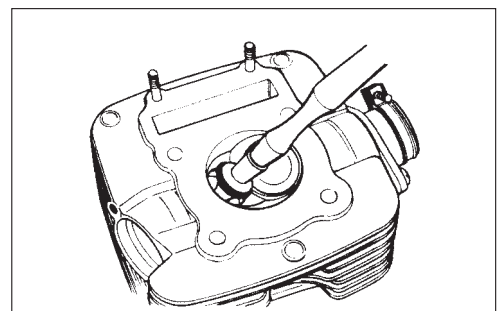

⚠ CAUTION

The valve seat contact area must be inspected after each cut.

Do not use lapping compound after the final cut is made. The finished valve seat should have a velvety smooth finish but not a highly polished or shiny finish. This will provide a soft surface for the final seating of the valve which will occur during the first few seconds of engine operation.

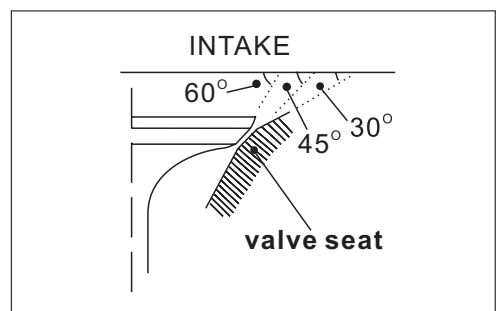

	INTAKE	EXHAUST
Valve seat angle	30°, 45°	15°, 45°
Valve width	0.9-1.1mm	

	Intake side		Exhaust side
45°	N-122	45°	N-122
30°	N-126	15°	N-121
60°	N-111		

TOOL 09916-21110: Valve reamer set

- Check the contact surface institute.
- If found any defective, service the valve seat.

- Using the 45° reamer, descale and cleanup the seat with one or two turns.

- Check the contact position. If the contact face of the valve is too high, finish it with 30° reamer to reduce the height.

- If the contact face of valve is too low finish it with 60° reamer to increase the height.
- Finish the valve seat surface again to standard range with 45° reamer.

NOTE:

The valve seat position will affect the contact surface of valve, this is very important to the good sealing.

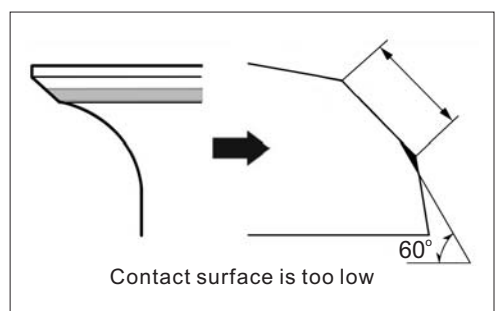
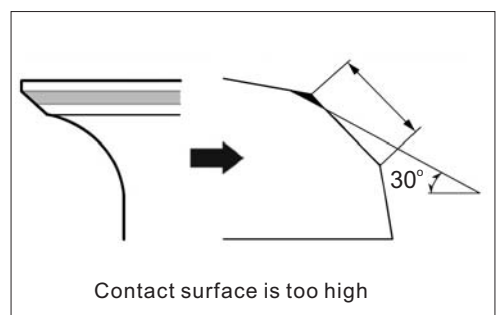
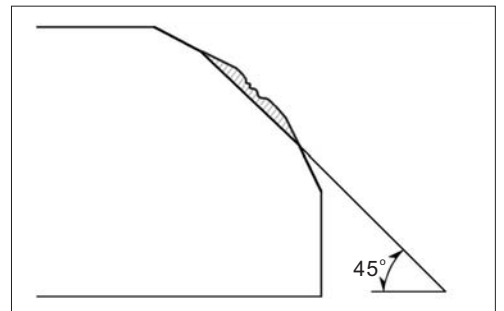
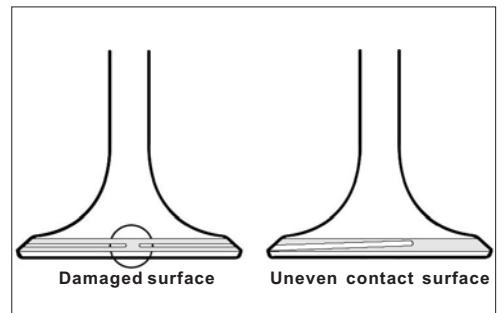
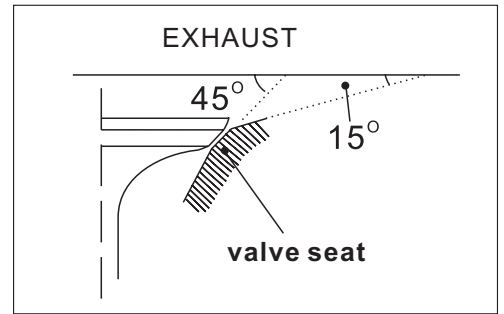

ENGINE

- Check the contact width.



09900-20103: Vernier calipers



Valve seat width: 0.9-1.1 mm

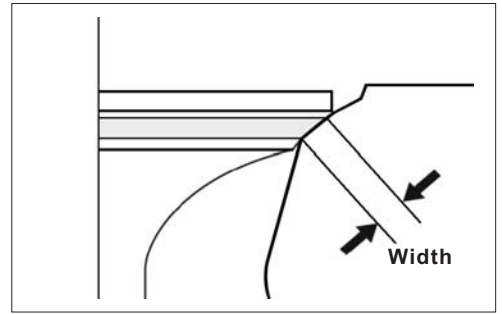

- If contact width is too small, cut the valve seat with a 45° reamer to raise.

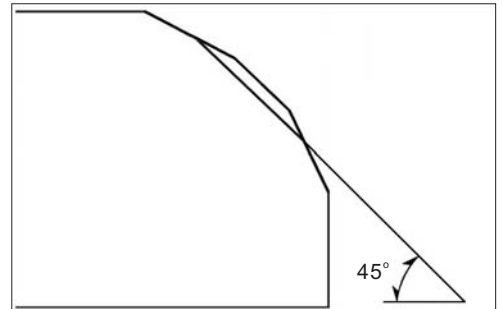

- If the valve seat contact width is too big, cut the valve seat out side 1/8 with a 30° reamer and cut the bottom 1/8 with a 60° reamer to lower.
- Check the contact width.
- If the width is out of the specification, repeat the operation above steps.

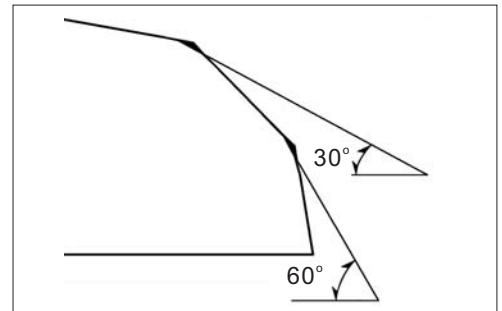

- After the desired seat position and width is achieved, apply a layer of lapping compound and use the reamer very lightly to service the valve seat. After servicing, clean up the remaining lapping compound on the cylinder head and valve.
- Check the valve seat contact surface again.

CAUTION

If the lapping pressure is too big, valve seat will be possibly distorted or damaged. Change the lapping tool angle frequently to prevent valve seat surface from being uneven. If the lapping compound get into the middle of the valve and valve guide will possibly lead to damage.

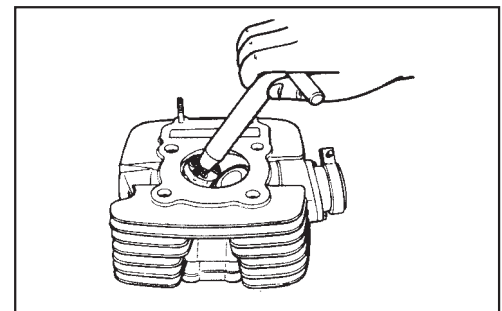

- Clean and assemble cylinder head and valve components.
- Fill intake and exhaust ports with gasoline to check for leaks and worn seals.
- If any leaks occur, check the valve seat and face for burrs or other defects that could prevent the valve from fully seating.

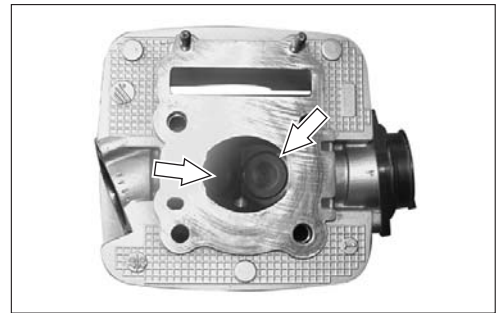

⚠ WARNING

Gasoline is very explosive, be sure to keep the work area well ventilated. Keep away from fire and spark.

CYLINDER HEAD ASSEMBLY

Reassemble the cylinder head in the reverse order of removal, pay attention to the following points:

- Clean the cylinder head thoroughly with a cleaning liquid and blow all passages with compressed air.



- Oil each seal, and drive them into the position.

⚠ CAUTION

Always use new oil seal.

- Lubricate all valves with Moly Paste.
- Insert the valves into valve guide pipes.



TMH 99000-25140: MOLY PASTE

NOTE:

When a valve spring is mounted, the seal ring side should face the combustion chamber. In order to avoid oil seal damage, the valve oil seal should be mounted while the valve is rotating slowly.

- Install the valve spring washer, inner spring, outer spring and retainer.

⚠ CAUTION

Install valve springs, making sure that the close-pitch end of each spring goes in first to rest on the head.

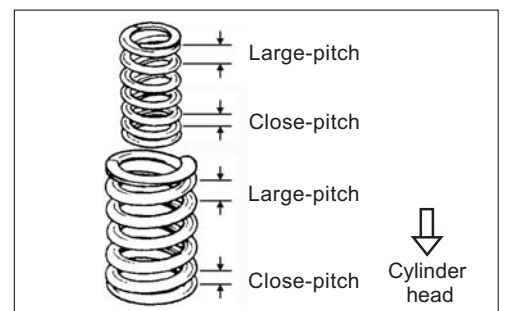

- Install the valve cotters with the special tool.

 11F14-018: Valve spring tools



CYLINDER HEAD COVER ASSEMBLY

- Clean the cylinder head cover throughly with detergent.
- Lubricate the rocker arm shaft with engine oil.
- Mount the rocker arm, rocker spring, flexuous washer and rocker arm to the cylinder head cover.

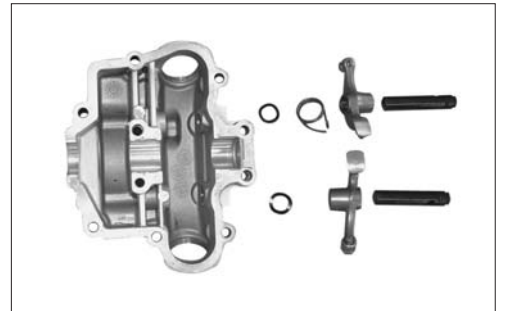

- Tighten the rocker arm shaft set bolts to the specified torque.

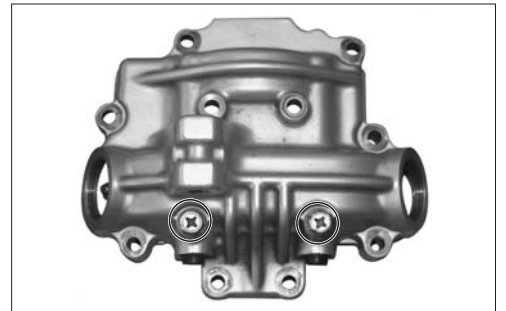

REASSEMBLY

Reassemble the cylinder head in the reverse order of dis-assembly, pay attention to the following points:

- Clean up the cylinder head surface.

 **CAUTION**

Do not let dirt and dust get into the engine.



- Install the dowel pins ① and cylinder head gasket.

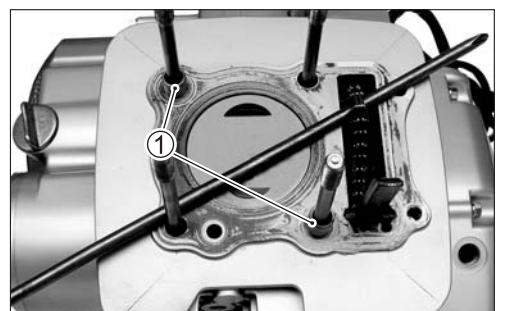

ENGINE

- Install the four nuts and washers, tighten the nuts to specified torque.



Cylinder head nut: 21-25 N•m

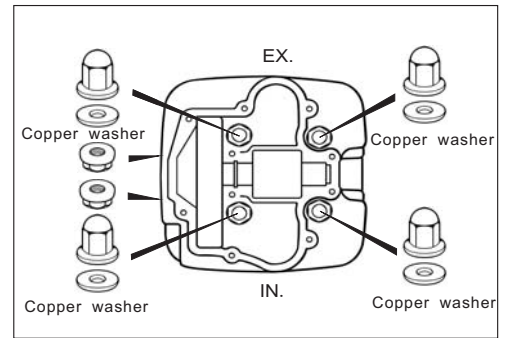

- Install the four cylinder side nuts, tighten the nuts to the specified torque.



Cylinder side nut: 8-12 N•m

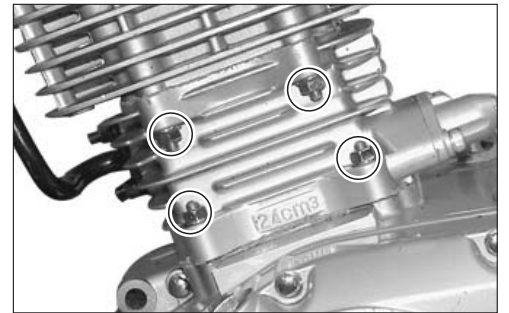

- Apply the Moly paste to the tip of cam.
- Install the camshaft, sprocket and chain.



99000-25100: Moly paste

CAUTION

Bring the piston to top dead center before installing the camshaft and cam sprocket. Align the marks on the camshaft so it is parallel with the surface of the cylinder head. Apply Thread lock to the bolts.



1303 99000-32030: Thread lock "1303"

- Wipe up the oil on the cylinder head fitting surface.
- Install the two dowel pins on the cylinder head.
- Apply the Bond No. 1215 to the mating surface of cylinder head.



99000-31110: Bond No. 1215

- Inspect the valve clearance. (Refer to page 2-5)

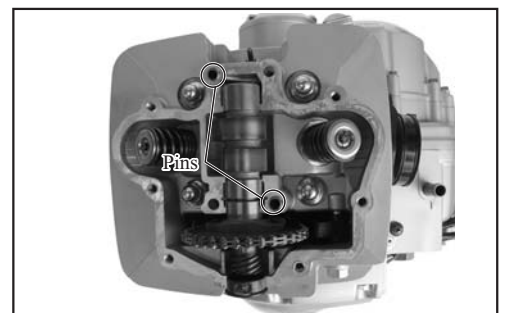

CYLINDER AND PISTON

CYLINDER REMOVAL

- Remove the cylinder head. (Refer to page 3-7)
- Remove the gasket, dowel pins and guide rod.
- Remove the cylinder.

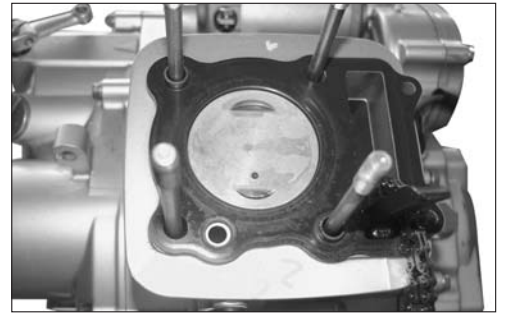

INSPECTION

- Clean the remaining gasket on the cylinder surface.
- Check the gasketed surface of the cylinder for distortion with a straightedge and thickness gauge.

DATA Cylinder distortion limit: 0.05 mm

TOOL 09900-20803: Thickness gauge

- Inspect the cylinder bore for wear or damage.
- Measure the cylinder bore diameter at six places. If any one of the measurements exceeds the limit, overhaul the cylinder and replace the piston with an oversize, or replace the cylinder.

DATA Cylinder bore diameter limit : 57.135 mm

TOOL 09900-20508: Cylinder gauge set

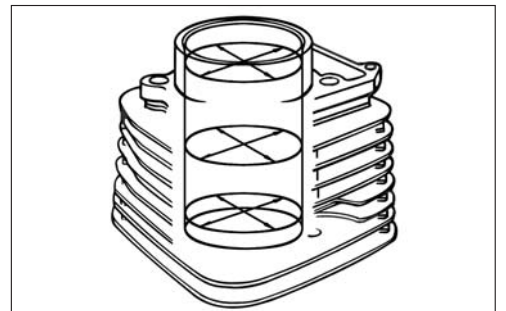
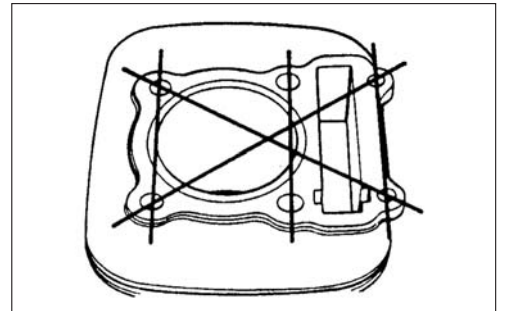

PISTON REMOVAL AND INSPECTION

REMOVAL

CAUTION

Place a clean rag over the cylinder base to prevent piston pin circlip from dropping into crankcase.

- Remove the piston pin circlip.
- Remove the piston pin and piston with the special tool.

TOOL 09910-34510: Piston pin remover

CAUTION

Hold the piston stably when taking out the piston pin to prevent the damage to conrod big end bearing.

- Remove the piston rings one by one by expanding the gap symmetry.

CAUTION

When removing the piston ring, be careful not to damage the piston. Do not expand the piston ring excessively since it is apt to be broken down.

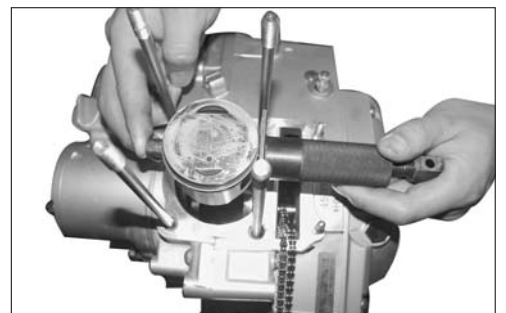

- Decarbonize the piston.

⚠ CAUTION

Using a soft-metal scrapper or discarded piston ring to decarbon the ring grooves of the piston. Do not use the steel brush or the piston will be scratched.



INSPECTION

- Temporary install the piston rings to the suitable position with marked side upward.
- Measure the clearance between the piston ring and groove with a thickness gauge.

DATA Piston ring-groove clearance limit:
1st: 0.180 mm 2nd: 0.150 mm

TOOL 09900-20803: Thickness gauge



- Measure the piston outside diameter at the place 8mm from the skirt end with a micrometer.

DATA Piston outside diameter limit:
56.844 mm at the 8 mm from the skirt end

TOOL 09900-20203: Micrometer (50~75 mm)



- Using a caliper gauge to measure the inside diameter of the piston pin bore.

DATA Piston pin bore inside diameter limit: 14.03 mm

TOOL 09900-20605: Caliper gauge

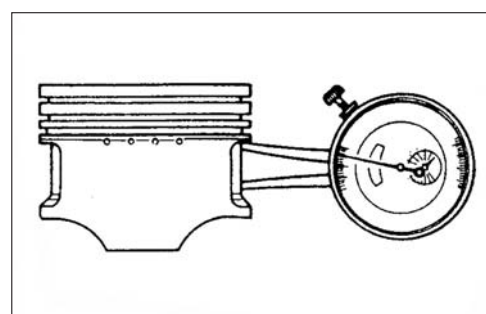

- Using a micrometer to measure the piston pin O.D..

DATA Piston pin O.D.: limit: 13.98 mm

TOOL 09900-20205: Micrometer (0-25)

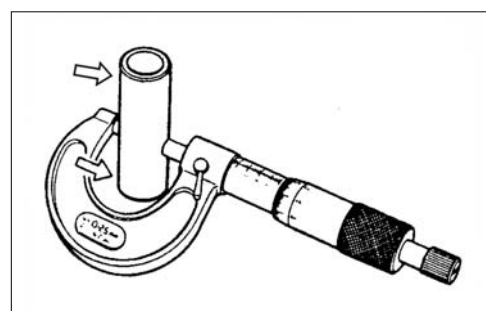

- Measure the conrod small end I. D.

DATA Conrod small end I.D.: limit: 14.04 mm

TOOL 09900-20605: Caliper gauge

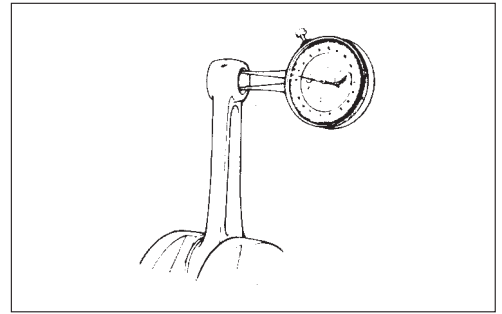

- Fit the rings in the cylinder, and measure each ring end gap with a thickness gauge. If any ring has an excess end gap, replace the ring.

DATA Piston ring end gap limit:

1st: 0.50 mm 2nd: 0.50 mm

TOOL 09900-20803: Thickness gauge

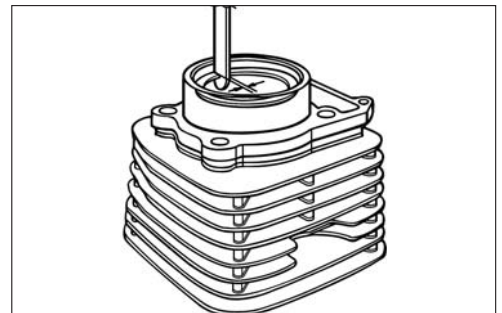

CAUTION

Make sure to fit the piston ring in the cylinder evenly with the piston head.

REASSEMBLY

Install the piston and cylinder in the reverse order of removal. Pay attention to the following points:

- Clean the top, skirt or groove of the piston.

CAUTION

Hold each piston ring with the piston rings properly spaced and insert them into the cylinder. Check to insure that piston rings are properly inserted in the the cylinder skirt.

- Carefully fit the piston rings to the piston with marked side to the top.

CAUTION

Be careful do not damage the piston ring and piston when installing the piston ring. Make sure to position the gaps of the top ring and 2nd ring as required.

- The gaps of two piston rings should be staggered at 120°.

CAUTION

Install the piston rings in the order of oil ring, 2nd ring and 1st ring. Do not align the gap of oil ring with expander ring.

- Piston rings should turn smoothly in the piston groove after assembly.

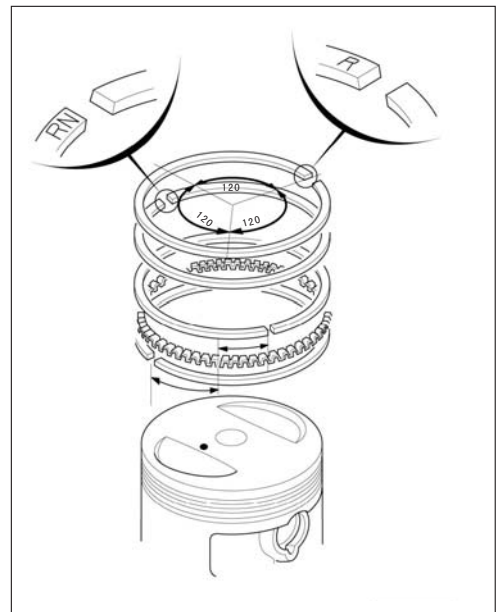

- Place a clean rag over the cylinder base to prevent piston pin circlip from dropping into crankcase, and then fit the piston pin circlip with long-nose pliers.

⚠ CAUTION

**Replace with a new piston pin circlip to prevent circlip slipping from position.
End gap of the circlip should not be aligned with the cutaway in the piston pin bore.**



- When installing the piston, the indent on the piston head must be located to the exhaust side.



- Before assembling the cylinder head, apply oil to conrod big end, small end and piston sliding part.
- Install the dowel pins ①, then install the gasket.

⚠ CAUTION

To prevent oil leakage, do not use the used gasket again, always use new one.



- Hold each piston ring with their properly spaced and insert them into the cylinder.
- Check to insure that the piston rings are properly inserted into the cylinder skirt.

NOTE:

When mounting the cylinder, after attaching camshaft drive chain ②, keep the camshaft drive chain taut, The camshaft drive chain must not be caught between cam drive chain sprocket and crankcase when crankshaft is rotated.

There is a holder for the bottom end of the cam chain guide cast in the crankcase. Be sure that the guide is inserted properly or binding of the cam chain and guide may result.

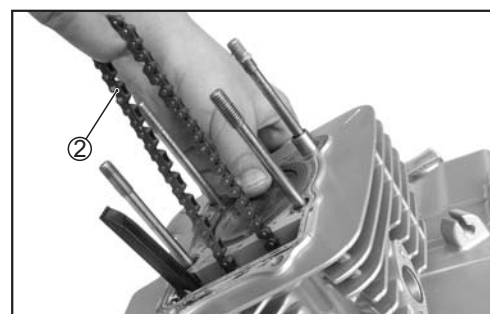

- Install the cylinder head. (Refer to page 3-15)

CLUTCH REMOVAL

- Drain the engine oil.
- Remove the oil filter cover nuts, take off the oil filter cover ①
- Remove the oil filter.

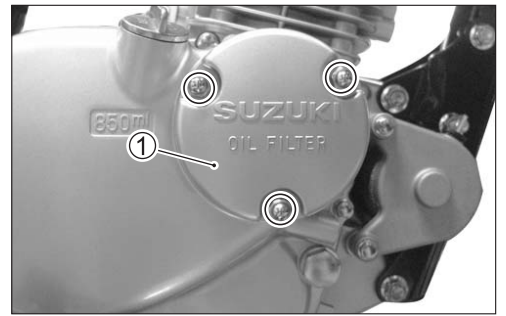

- Remove the clutch cover screws diagonally, take off the clutch cover ②.
- Remove the gasket and dowel pins.

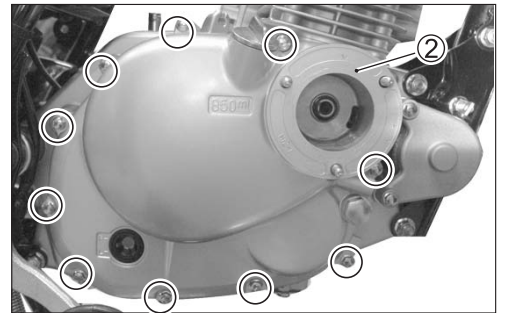

- Remove the clutch spring bolts diagonally.

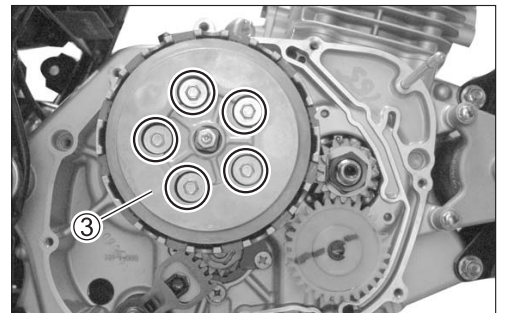

- Remove clutch pressure plate ④, washer ⑤, bearing ⑥ and clutch push block ⑦.



- Remove the clutch push rod ⑧.

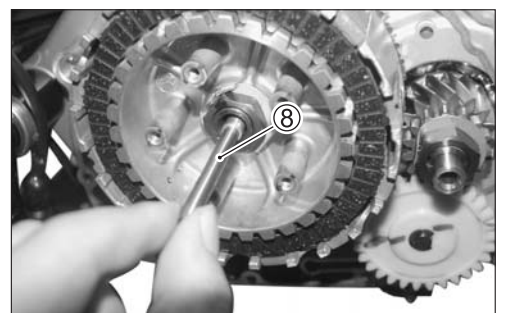

- Remove the clutch drive plates and driven plates.



- Flatten the lock washer..
- Hold the clutch hub with the special tool, remove the clutch hub nut and lock washer.

TOOL 09920-53710: Clutch sleeve hub holder



- Remove the clutch hub and washer.

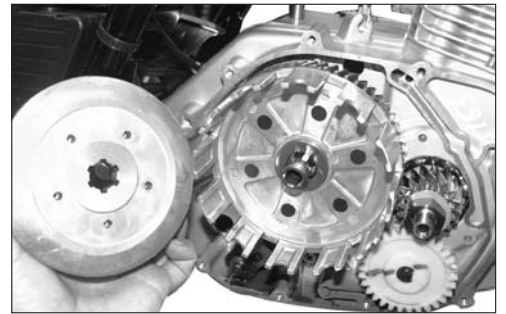

- Remove the primary driven gear, spacer and washer.



INSPECTION

- Measure the thickness and claw width of each drive plate with vernier calipers. Replace the drive plates found to have worn down to the limit.

TOOL 09900-20103: Vernier calipers

DATA Drive plate thickness limit: 2.6 mm

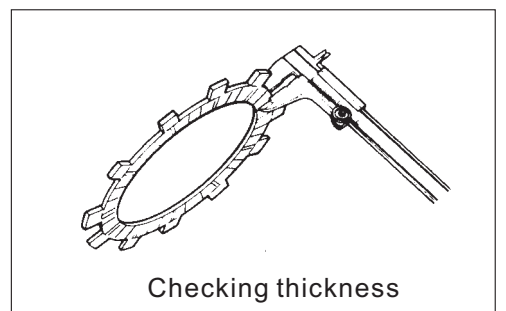

DATA Drive plate claw width limit: 11.0 mm

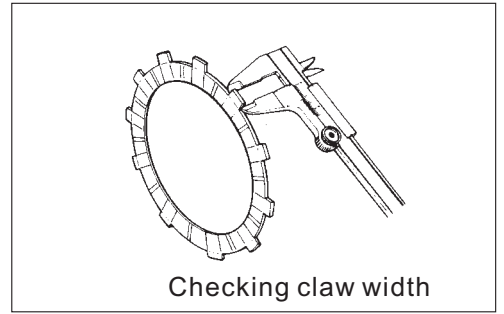

- Measure each driven plate for distortion with a thickness gauge. Replace all driven plates if any of them exceeds the limit.

TOOL 09900-20803: Thickness gauge

DATA Driven plate distortion limit: 0.1 mm

CAUTION

Replace the drive and drive plates as a whole set which exceed the limit.

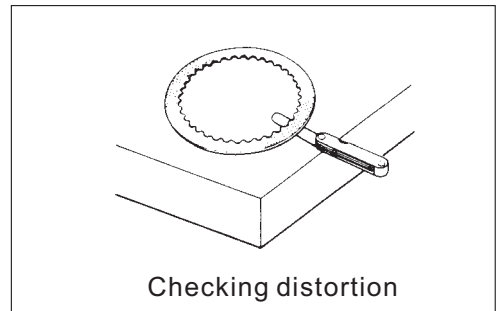

- Measure the clutch spring free length.

DATA Clutch spring free length limit: 29.45 mm

TOOL 09900-20103: Vernier calipers

CAUTION

Replace all the springs if any spring is not within the limit.

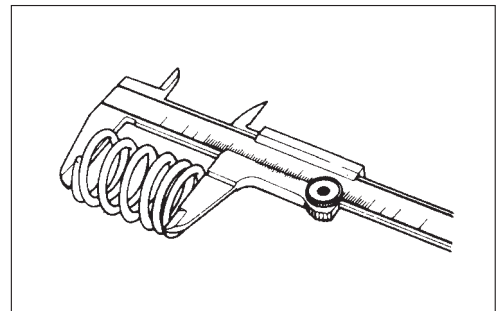

- Inspect the clutch release bearing for any abnormality, particularly cracks, to decide whether it can be reused or should be replaced.
- Smooth engagement and disengagement of the clutch depend on the condition of this bearing.

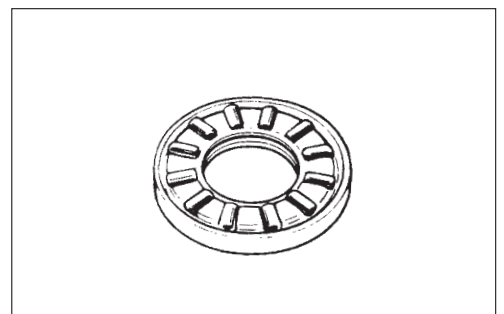

- Primary driven gear is composed as shown.

- ① Primary driven gear ④ Rivet
- ② Damper ⑤ Clutch housing
- ③ Plate

If the internal damper wears, the play is generated between gear and housing, causing abnormal noise. If the play is too big, replace the primary driven gear assembly with a new one.

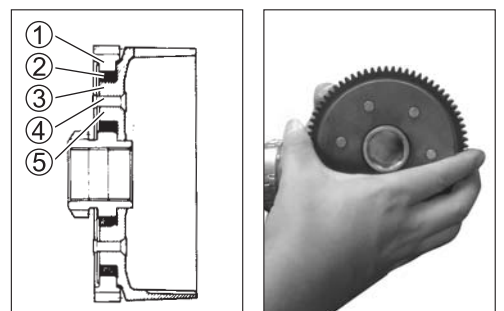

REASSEMBLY

Reassemble the clutch in the reverse order of removal, pay attention to the following points:

- Install the washer, spacer, primary driven gear assembly, washer and clutch drive hub.
- Install the lock washer, tighten the clutch sleeve hub nut to the specified torque.



Clutch sleeve hub nut: 30-50 N·m



09920-53710: Clutch driven hub holder

- Bend the clutch sleeve hub washer to the nuts.
- Install the clutch drive plates and driven plates.

⚠ CAUTION

Install the drive plates as shown in the illustration.



- Install the clutch push rod, push piece, bearing, washer and pressure plate.
- Install the clutch spring, tighten the clutch spring bolts diagonally.

⚠ CAUTION

Set the marked side of clutch spring faces outside.

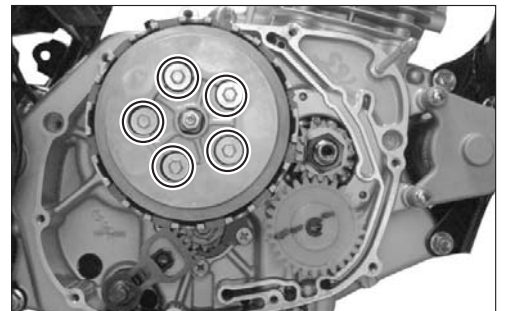

- Install a new gasket and pins.
- Install the clutch cover, and tighten clutch cover bolts diagonally.

⚠ CAUTION

Use new gasket to prevent oil leakage.

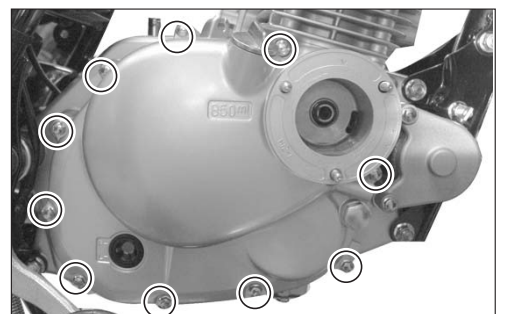

- Install a new oil seal ring.
- Install the oil filter and oil filter cover.
- Tighten three nuts.
- Install and adjust clutch cable, and pour engine oil. (Refer to page 2-8 and page 2-7)

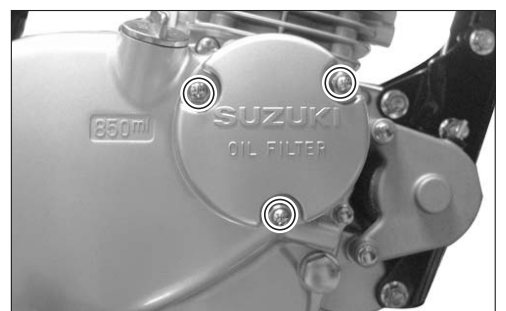

OIL PUMP REMOVAL

- Remove the clip, oil pump driven gear and oil pump driven gear pin.

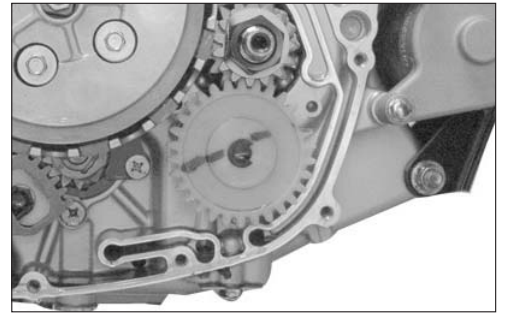

- Remove the oil pump.

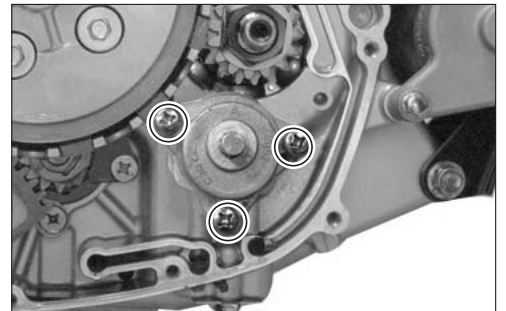

INSPECTION

- Rotate the oil pump by hand and check whether it moves smoothly. If the oil pump does not move smoothly, replace it.



REASSEMBLY

- Apply a small quantity of engine oil to the inside the oil pump before assembly.
- Apply the Thread lock "1342" to the oil pump mounting bolts and tighten the bolts.

 **99000-32050: Thread lock "1342"**

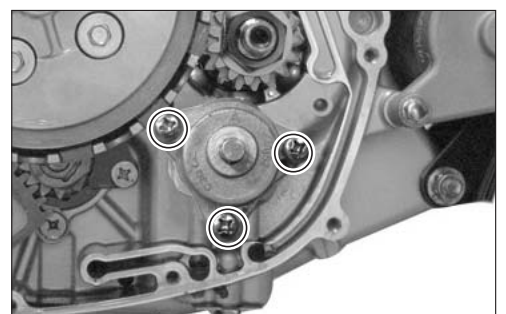

GEAR SHIFTING SHAFT REMOVAL

- Remove gear shifting lever.
- Remove the clutch. (Refer to page 3-20)



- Remove the gear shifting shaft ①.
- Remove the screws, gear shifting cam guide plate ② and ③.
- Remove the gear shifting driven gear ④ , pawl ⑤ , gear shifting pawl pin ⑥ and return spring ⑦.

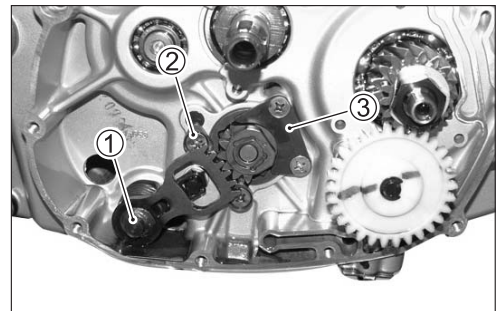

INSPECTION

- Check the return spring ⑦ for damage, gear shifting shaft ⑧ for wear or bending.

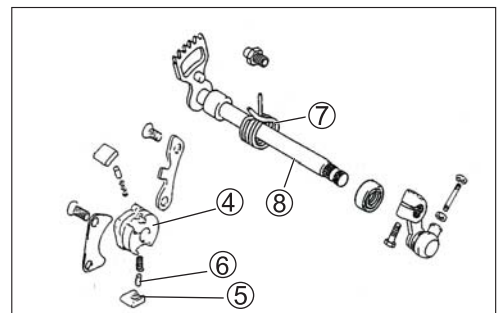

REASSEMBLY

Reassemble the gear shifting shaft in the reverse order of removal, pay attention to the following points:

- When installing the gear shifting pawls to the driven gear, the large shoulder **A** must face to the outside as shown.
- Install the cam guide. Apply a small quantity of THREAD LOCK "1342" to the threaded parts of the securing screws.

 1342 99000-32050: Thread lock "1342"

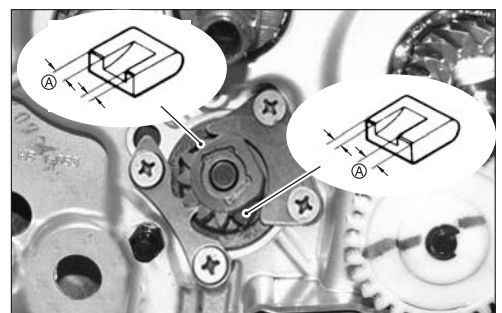

GENERATOR & STARTING CLUTCH REMOVAL

- Disconnect the generator coupler.

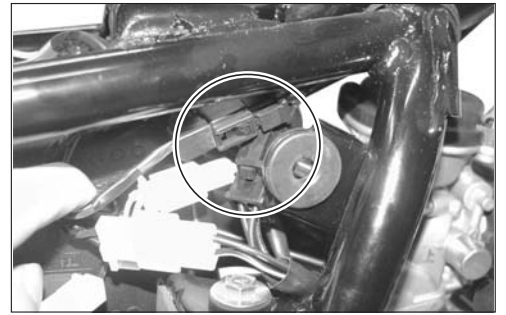

- Remove the engine sprocket cover.

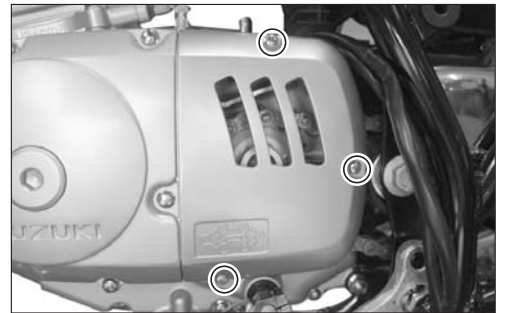

- Remove the starting motor by removing the bolts.

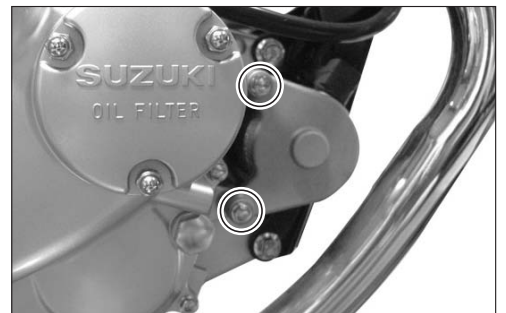

- Remove the generator cover
- Remove the gasket and dowel pins.

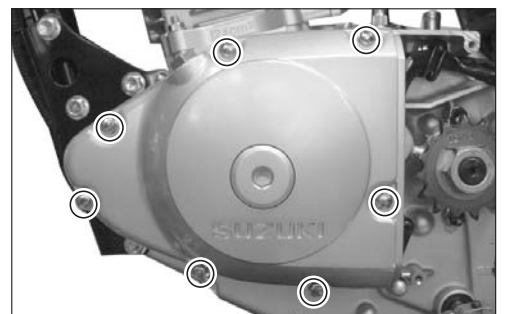

- Remove the generator rotor nut while holding the generator rotor with the special tool.

TOOL 11F14-001: Rotor holder

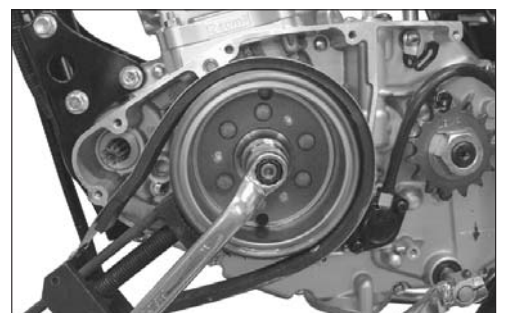

- Remove the generator rotor and key with the special tool.

- TOOL** 11F14-001: Rotor holder
 11F14-003: M16 screw
 11F14-005: Generator rotor remover M30

CAUTION

Do not damage the key slot and crankshaft when removing the key.

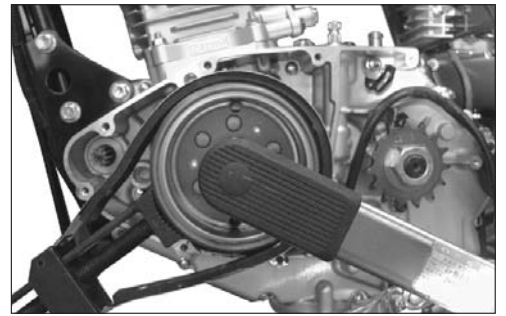

- Remove the starter clutch gear.



- Remove the roller ①, push piece ②, and spring ③ from the starting clutch.

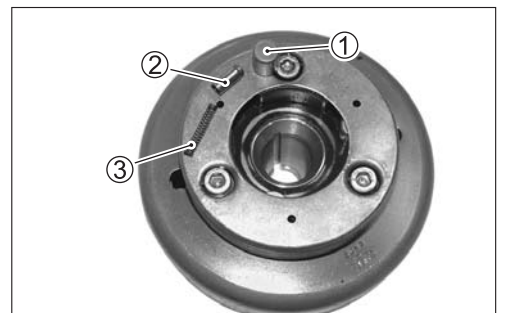

- Hold the generator rotor with the special tool, remove the starting clutch bolt.

- TOOL** 11F14-001: Rotor holder

CAUTION

Do not remove the starting clutch unless necessary.

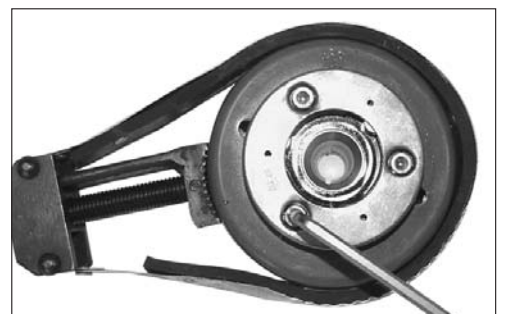

- Remove the generator stator ④.
- Remove the trigger coil ⑤.

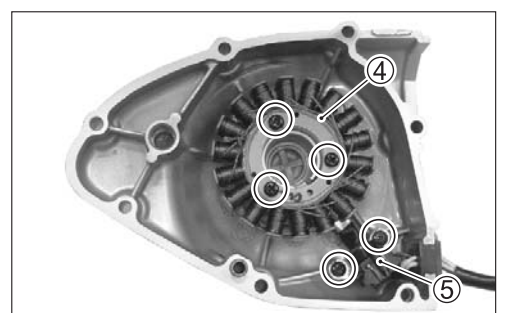

INSPECTION

- Install the starter driven gear to the starter clutch and turn the starter driven gear by hand to inspect the starter clutch for a smooth movement. The gear turns one direction only. If a large resistance is felt to rotation, inspect the starter clutch for damage or inspect the starter clutch contacting surface of the starter driven gear for wear or damage. If they are found to be damaged, replace them with new ones.

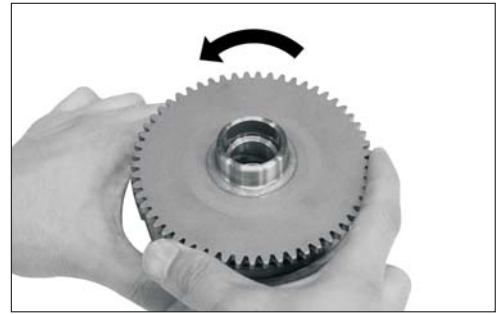

- Inspect the starter clutch for wear, damage or abnormality moving.



⚠ CAUTION

Replace the whole set of springs, if starter clutch springs are removed.

REASSEMBLY

Reassemble in the reverse order of removal, pay attention to the following points:

- Install the stator ①, cable pressure plate, apply the Thread lock to the bolt and tighten it.
- Install the trigger coil ②, apply Thread lock to the screw head and tighten it.
- Apply bond to the grommet ③ groove.

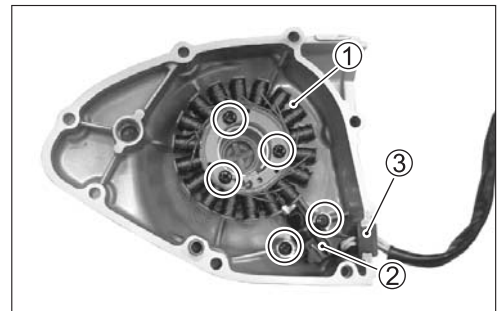

 99000-32050: Thread lock "1342"

 99000-31140: Bond "1207B"

- Clean the starter clutch, apply engine oil to the separate ring, Fit the starter clutch on the rotor.
- Apply the Tread lock to the starter clutch, tighten the bolts to the specified torque.

 Starter clutch bolt: 8-12 N•m

 99000-32030: Thread lock "1303"

 11F14-001: Rotor holder

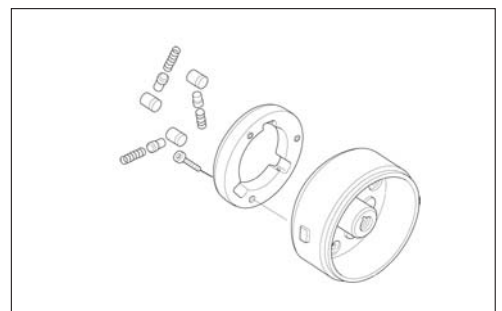

- Fit the key in the crankshaft key slot.

⚠ CAUTION

When installing the key, take care not to damage the key slot and crankshaft.



- When installing the rotor, align the rotor key slot with the key on the crankshaft.
- Install the generator nut, tighten the nut to the specified torque.

🔧 Generator nut: 50-60 N•m

🔧 TOOL 11F14-001: Rotor holder

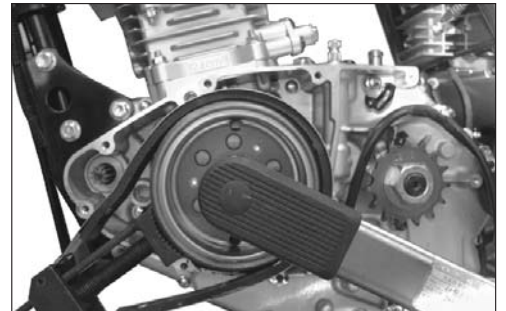

CRANKSHAFT, TRANSMISSION AND KICKSTARTERSET.

REMOVAL

- Remove the cylinder head and cylinder. (Refer to page 3-7)
- Remove the clutch and gear shifting shaft.(Refer to page 3-21)
- Remove the generator rotor and starting clutch. (Refer to page 3-27)
- Remove the neutral locate screw plug and oil filter cover.

⚠ CAUTION

Do not take off the neutral locating screw plug (inner hexagon) when drain the engine oil.

- Clamp the conrod small end with conrod holder, remove the lock washer, remove the primary drive gear lock nut.

TOOL 09910-20116: Conrod holder

⚠ CAUTION

Primary drive gear lock nut is left-hand nut.

- Remove the gear shifting cam guide.
- Remove the gear shifting cam driven gear assembly.
- Remove the gear switch position screws, take off the gear position switch, pin and spring.
- Remove the two bolts, take off the drive shaft oil seal block plate.

- Remove the crankcase mounting bolts.

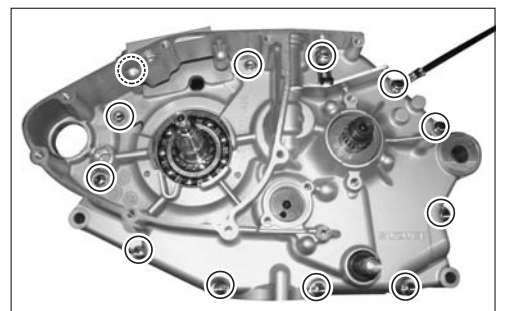
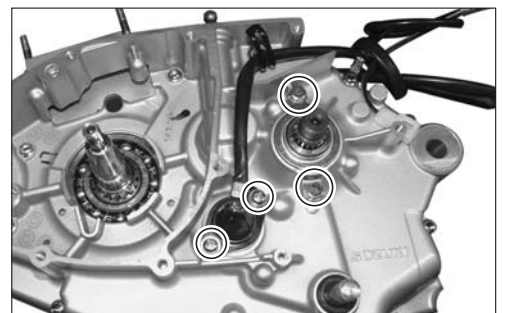
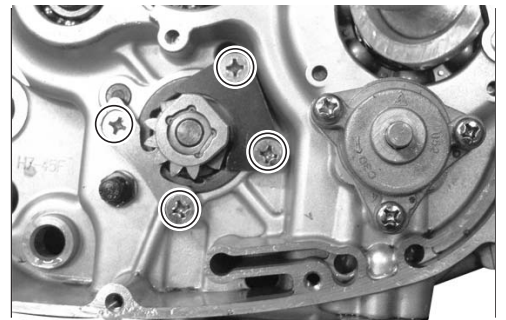
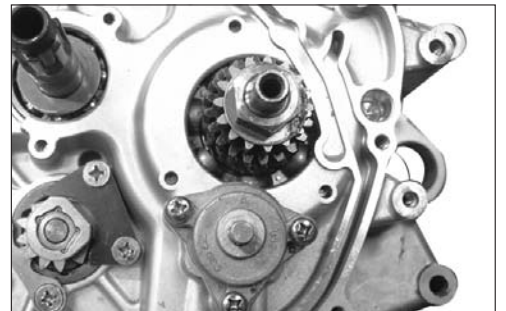
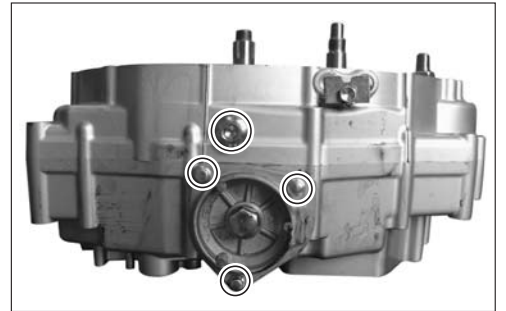

- Fit the crankcase separator, so that the tool plate is parallel with the end face of the crankcase.
- Remove the right crankcase with the special tool.

TOOL 09920-13120: Crankcase separator

⚠ WARNING

The crankshaft and transmission components must remain in the left crankcase half, This is necessary because the gear shifting cam stopper is mounted on the left crankcase half and will be damaged if the transmission components remain in the right half.

- Remove the gear shifting hub fixing spring.
- Remove the gear shifting shafts, take off the forks.
- Remove the gear shifting hub.

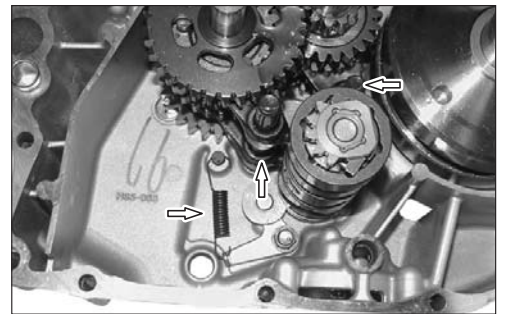
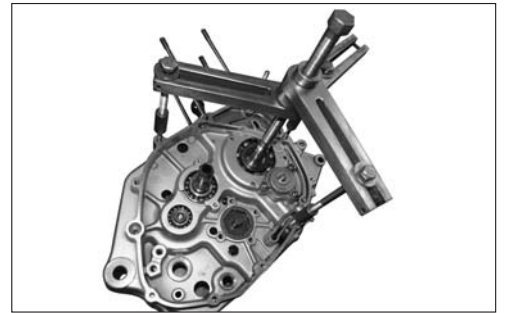

NOTE:

Two kinds of gear shifting forks, ① and ②, are used. They resemble each other very closely in external appearance and configuration. Carefully examine the illustration for correct installing positions and directions.

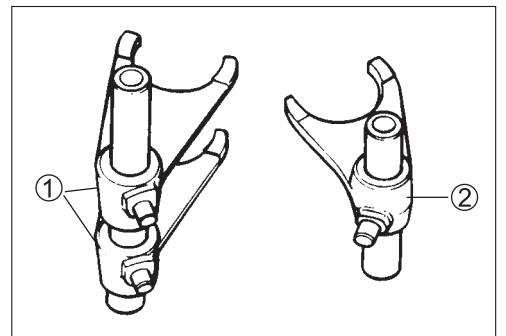

- Remove the transmission assembly.



- Remove the crankshaft with the special tool.

TOOL 09920-13120: Crankcase separator

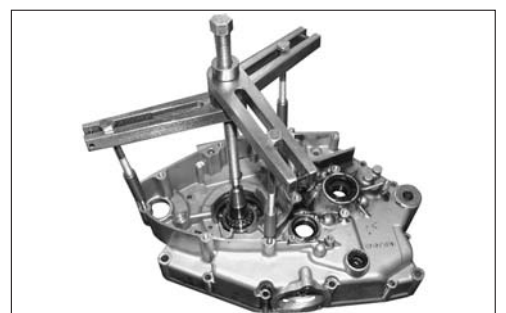

INSPECTION

- Measure the big end of the conrod side clearance with a thickness gauge.

DATA Conrod big end clearance limit: 0.5 mm

TOOL 09900-20803: Thickness gauge

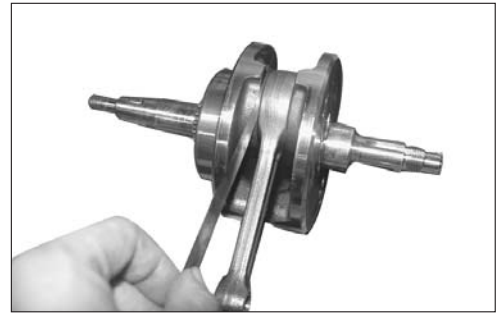

- Support the crankshaft with "V" blocks as shown.
- Measure the crankshaft runout with the dial gauge.

DATA Crankshaft runout limit: 0.05 mm

TOOL 09900-20606: Dial gauge (1/100 mm)
09900-20701: Magnetic stand
09900-21304: V-block

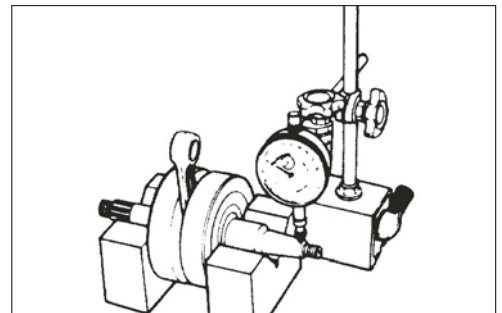

- Using a thickness gauge, check the shifting fork clearance in the groove of its gear. If the clearance limit exceeds by any gear, determine whether the gear or the gear shifting fork should be replaced by measuring the thickness and groove width.

DATA Fork to groove clearance limit: 0.5 mm

TOOL 09900-20803: Thickness gauge

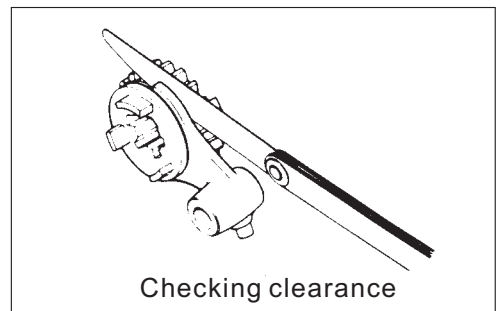

- Measure the gear shifting fork thickness.

DATA Fork thickness:

No.1 and 2: 4.8-4.9 mm No.3: 5.3-5.4 mm

TOOL 09900-20103: Vernier calipers

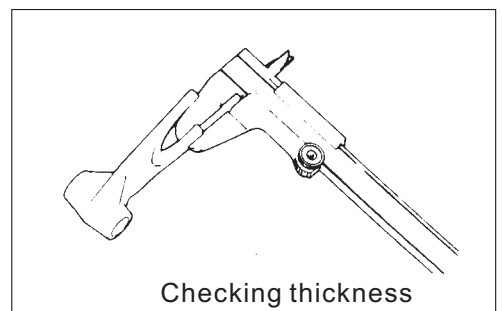

- Measure gear shifting groove width.

DATA Gear shifting groove width:

No.1 and 2: 5.1 mm No.3: 5.5-5.6 mm

TOOL 09900-20103: Vernier calipers

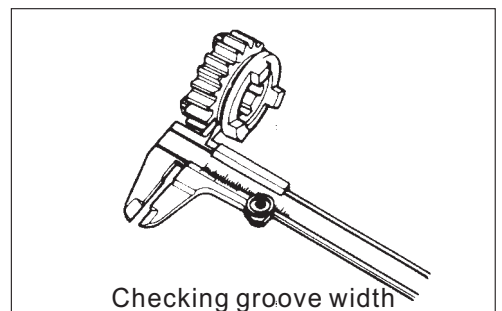

- Inspect the gear shifting hub guide slot.
- Replace the gear shifting hub if the guide slot is damage.



- Inspect each bush, gear inner surface and gear teeth face for abnormal wear or poor lubrication.

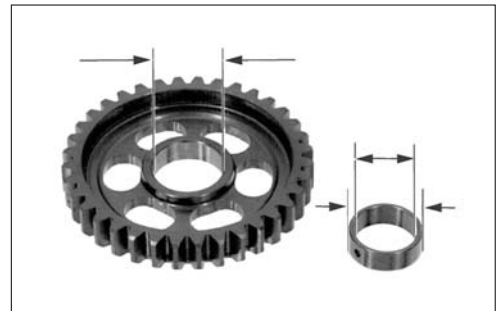

- Rotate the inner race by hand to inspect for an abnormal noise and a smooth rotation and inspect to see if the outer race is movable in the crankcase.
- Replace the bearing if there is something unusual.

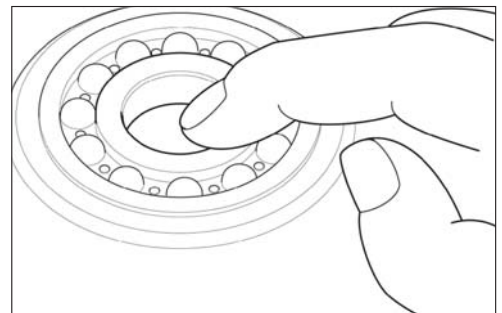

BEARING REMOVAL

- Remove the bearing locating plates on left and right crankcase.

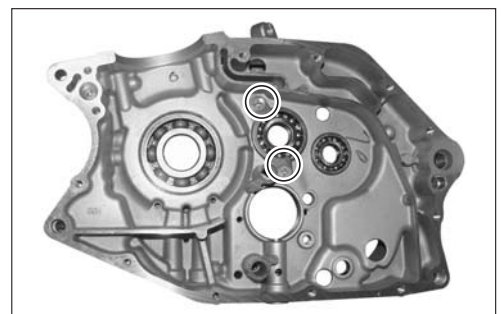

- Remove the crankshaft bearing, countershaft bearing and driveshaft bearing with the special tool.

 **09921-20240: Bearing remover**



REASSMEBLY

Reassemble in the reverse order of removal, pay attention to the following points:



BEARING

- Install the bearings on the left and right crankcase with the special tool.

TOOL 09913-70210: Bearing installer

CRANKSHAFT

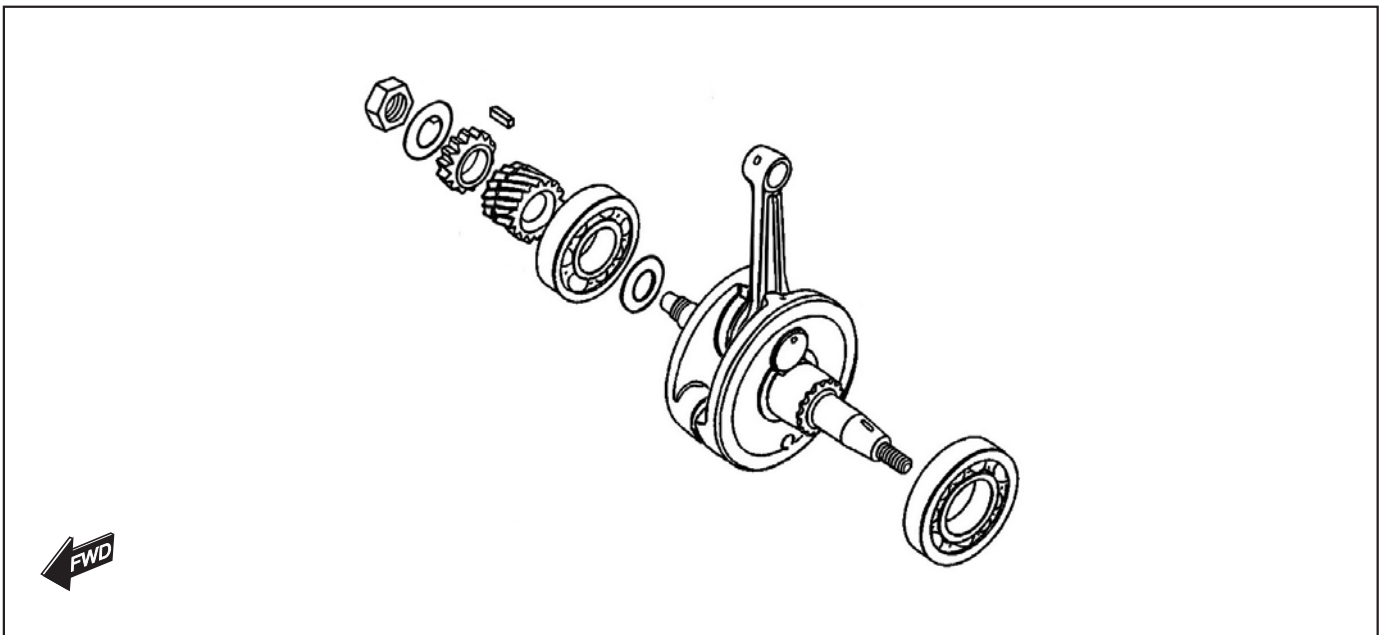

- Decide the width between the webs when rebuilding the crankshaft.

DATA Width between webs:
Standard: 52.9-53.1 mm

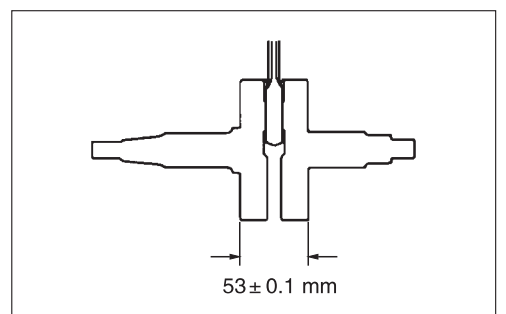

- When mounting the crankshaft in the crankcase, it is necessary to pull its left end into the crankcase.

TOOL 09910-32812: Crankshaft installer



▲ CAUTION

Never fit the crankshaft into the crankcase by striking it with a plastic hammer. Always use the special tool, otherwise crankshaft alignment accuracy will be affected.

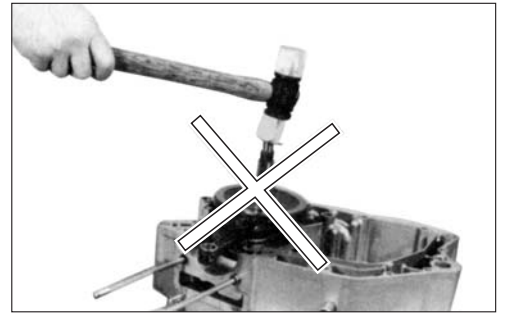

TRANSMISSION

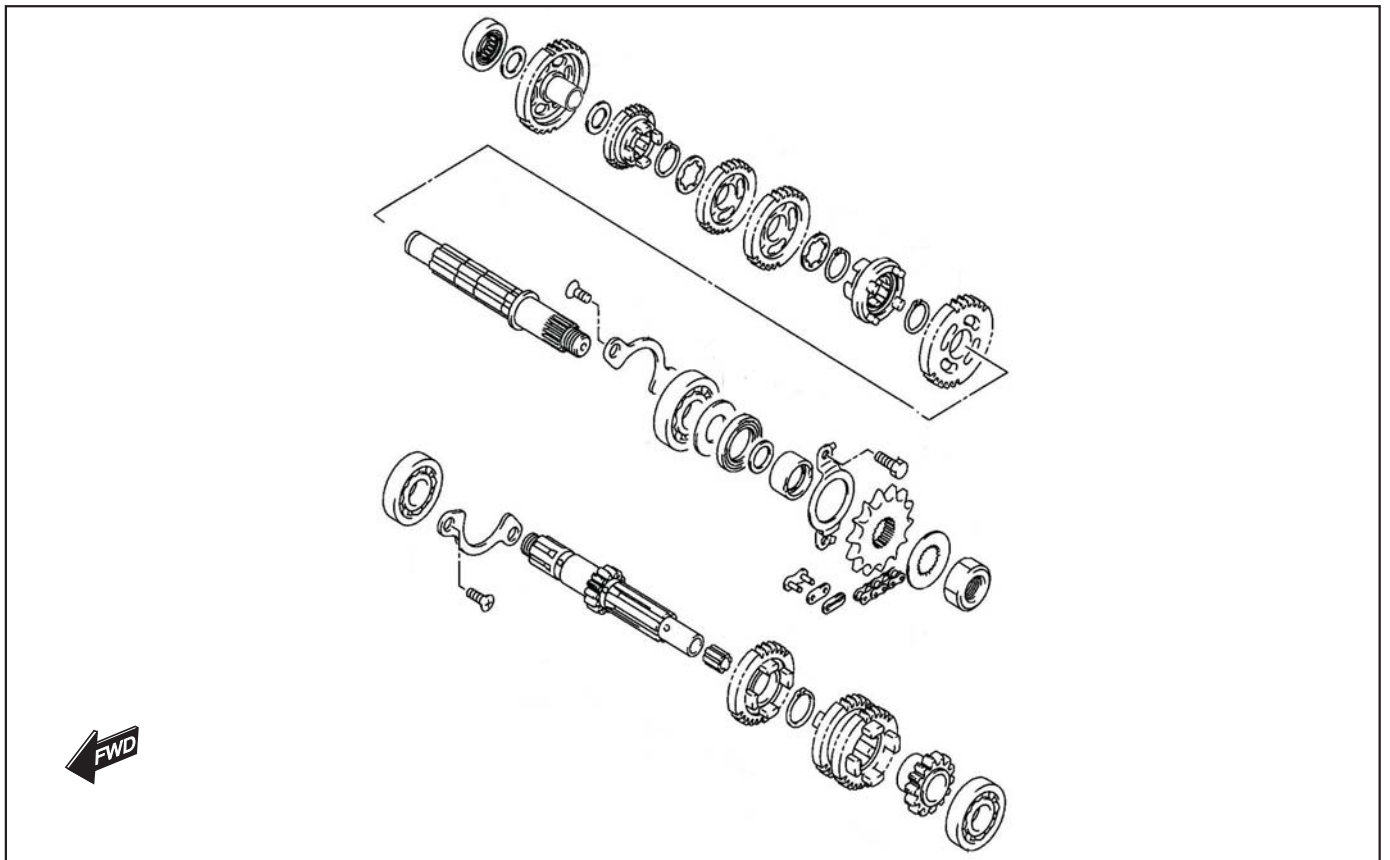

▲ CAUTION

Never reuse a circlip. After a circlip has been removed from a shaft, it should be discarded and a new circlip must be installed. When installing a new circlip, care must be taken not to expand the end gap larger than required to slip the circlip over the shaft. After installing a circlip, always insure that it is completely seated in its groove and securely fitted.

ENGINE

- Press-fit 2nd drive gear onto the counter shaft. Before reassembling, coat the internal face of the 2nd drive gear with Thread Lock super "1303B" and install it so that the length ① as shown in Fig.

DATA Countershaft length ①: 87.8-88.1 mm

1303 99000-32030: Thread lock super "1303"

⚠ CAUTION

The procedure may be performed only twice before shaft replacement is required.

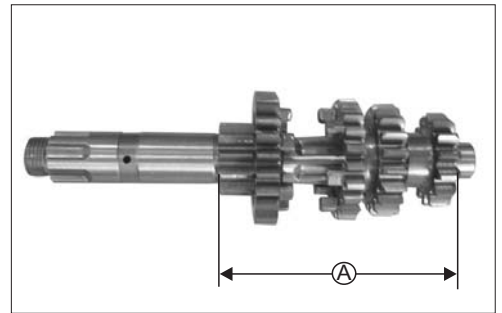

GEAR SHIFTING HUB AND FORKS

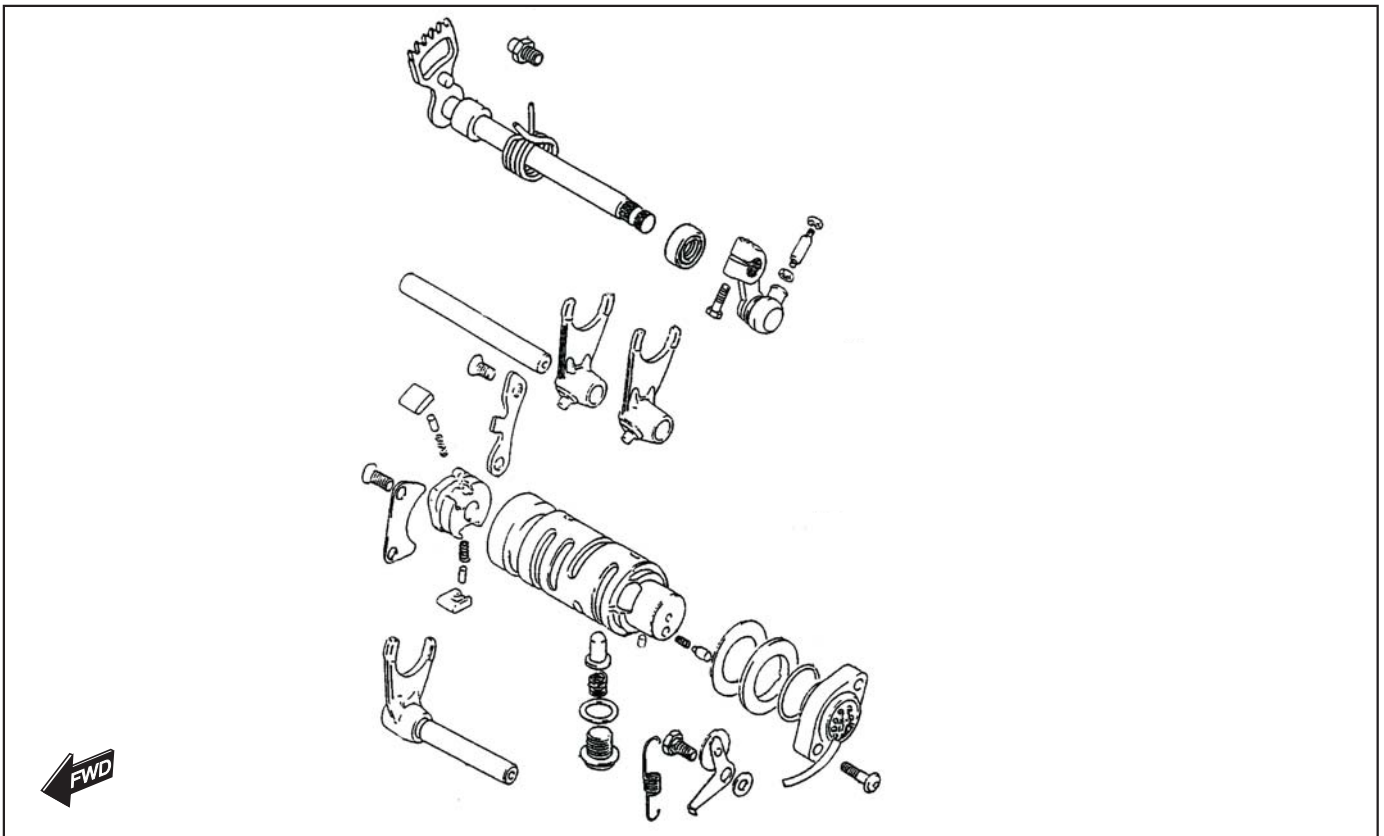

- Fit the gear shifting hub on the crankcase. Position the hub as shown in Fig. so that the gear shifting forks can be installed easily.

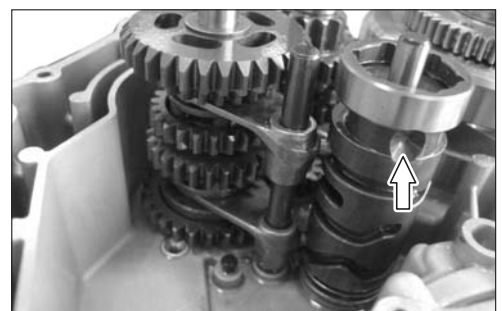

NOTE:

Two kinds of gear shifting forks, ① and ②, are used. They resemble each other very closely in external appearance and configuration. Carefully examine the illustration for correct installing positions and directions.

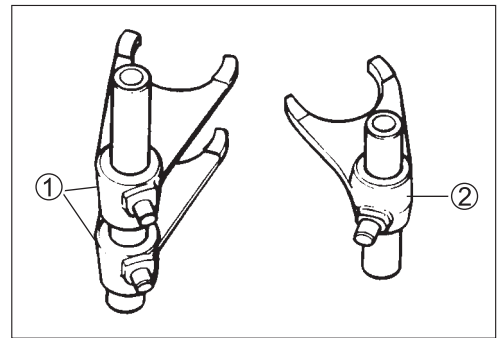

CRANKCASE

- Coat Super Grease “A” to the lip of oil seals.
- Remove sealant material on the fitting surfaces of right and left halves of crankcase and thoroughly remove oil stains.
- Fit dowel pins on the left half.
- Apply engine oil to the big end of the crankshaft and all parts of the transmission gears.
- Apply Bond No. 1215 uniformly to the fitting surface of the left half of the crankcase, and after waiting a few minutes, fit the right half on the left half.

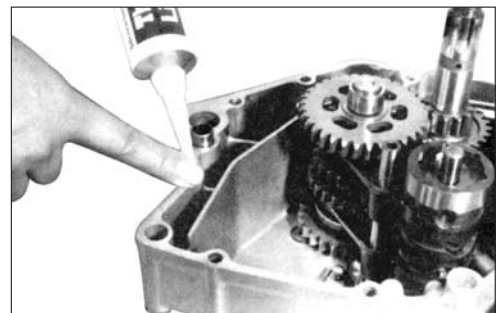

 **99000-25010: Super grease “A”**

 **99000-31110: Bond No.1215**

CAUTION

After the gear shifting hub driven gear, guide, shifting shaft and neutral stopper have been fitted, confirm that gear change is normal while turning the countershaft and driveshaft. If gear change is not obtained, it means that assembly of gears or installation of gear shifting fork is incorrect. If this is the case, disassemble and trace the mistake.

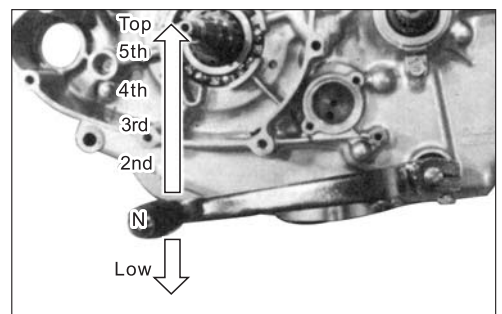

- Hold the conrod small end with conrod holder, tighten the primary drive gear nut to the specified torque. Bend the washer to the primary drive gear nut.

 **Primary drive gear nut: 40-60 N·m**

 **09910-20116: Conrod holder**

- Install the generator and starting clutch. (Refer to page 3-30)
- Install the clutch and gear shifting shaft. (Refer to page 3-24 and 3-26)
- Install the cylinder and cylinder head. (Refer to page 3-20 and 3-15)
- Install the engine, and add the oil. (Refer to page 3-6)



FUEL AND LUBRICATION

CONTENTS

FUEL COCK.....	4-1
CARBURETOR	4-3
LUBRICATION SYSTEM.....	4-7

FUEL COCK AND FUEL FILTER REMOVAL

- Turn the fuel cock to "●" position shown in photo and disconnect fuel hose from the fuel cock.
- Place a clean pan under the fuel cock assembly, turn fuel cock to "∩" position and drain the gasoline.

WARNING

Gasoline is very explosive. Extreme care must be used.

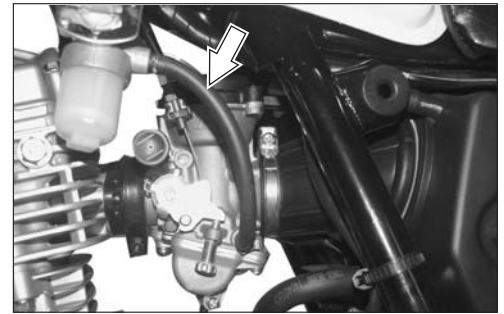

- Remove the fuel filter.

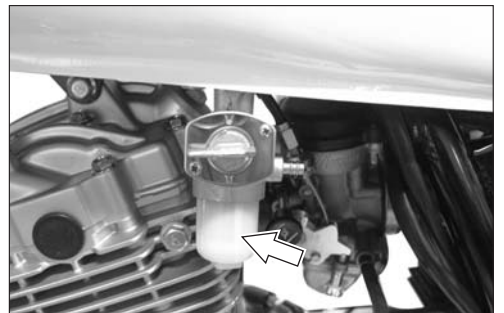

- Remove the fuel cock.



CLEANING

- Clean filter with compressed air and inspect for cracks.

CAUTION

Replace the fuel filter with a new one if it is damaged or cracked.

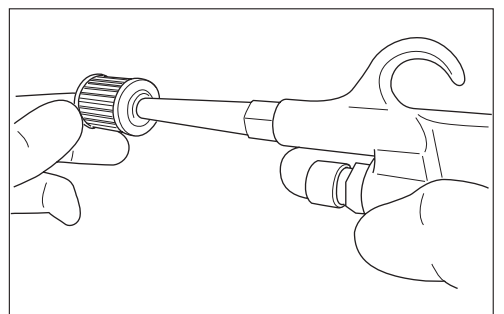

- Rust from the fuel tank tends to build up in the filter, which, when the filter has been neglected for a long period, inhibits the flow of fuel. Remove the rust from the filter using compressed air.



REASSEMBLY

Reassemble the fuel cock or fuel filter in the reverse order of removal. Pay attention to the following points:

- Install the fuel cock.

WARNING

Gasket must be replaced with a new one to prevent leakage.

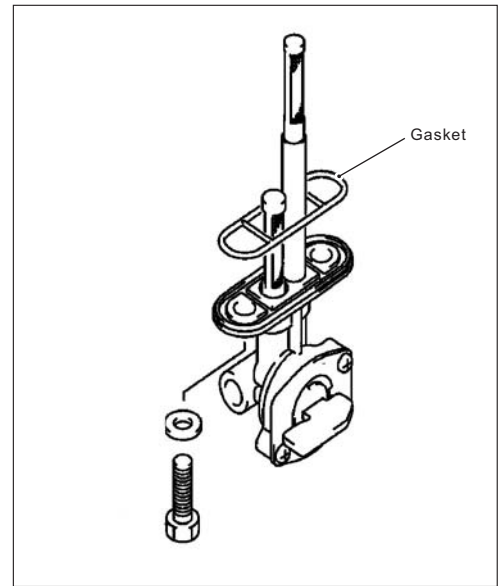

- Install the fuel filter.

CAUTION

Do not miss to install the O-ring **C** during the remounting.

- A** Filter cup
- B** Fuel filter
- C** O-ring

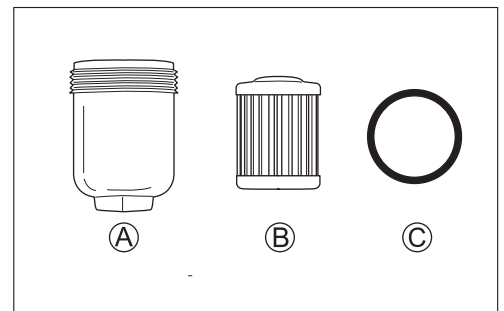

CARBURETOR

CARBURETOR CONSTRUCTION

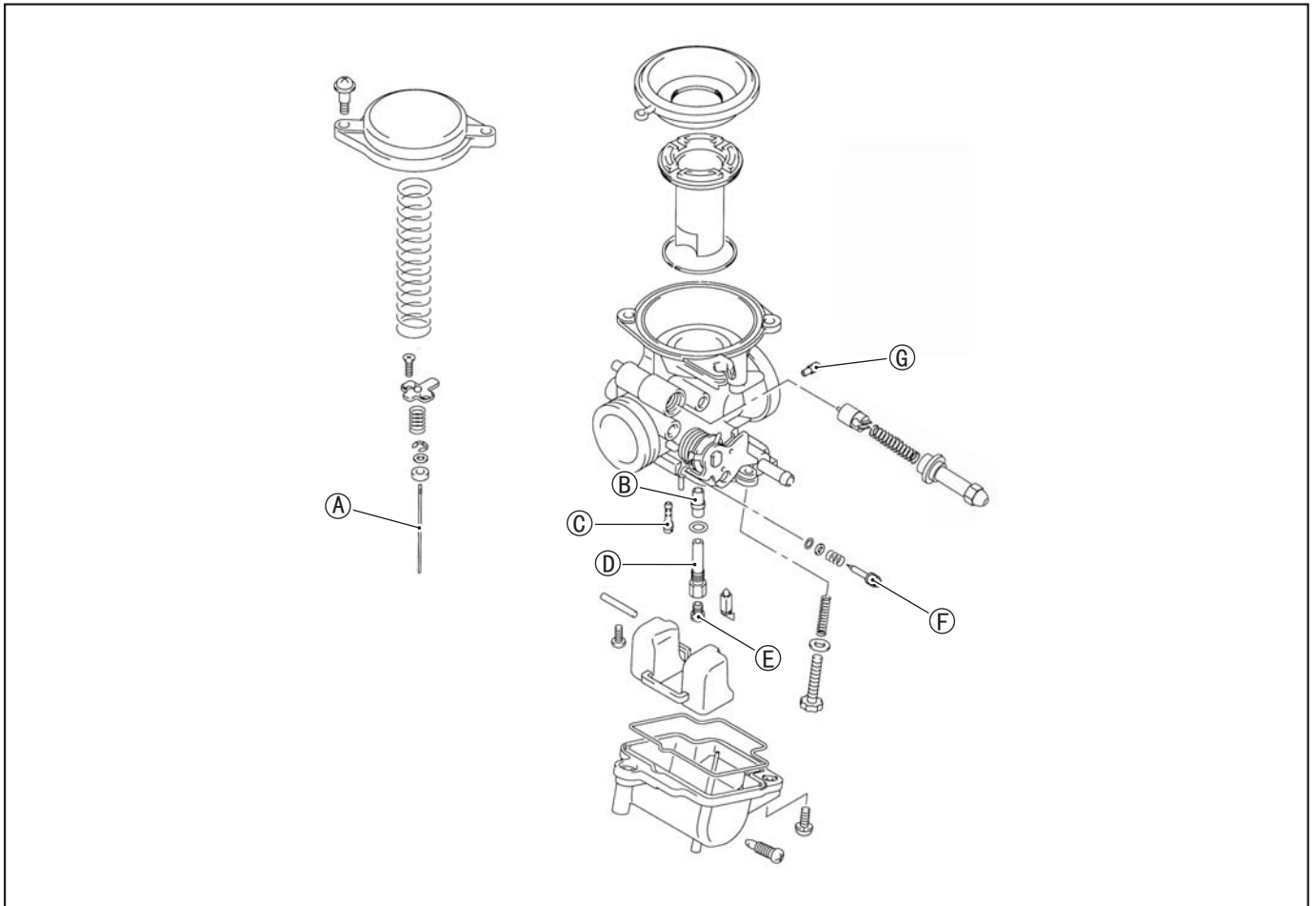

ITEM	SPECIFICATION	ITEM	SPECIFICATION
Carburetor type	BS26	Bubbling jet ④	Ø 3
I.D. No.	054G	Main jet ⑤	# 110
Needle ①	4DH41-2	Idle air screw ⑥	2,5/8 turn out
Needle jet ②	P-0(390)	Idle air jet ⑦	# 1.25
Idle jet ③	# 12.5	Idle	1400±100 r/min

REMOVAL AND DISASSEMBLY

- Disconnect the carburetor balance pipe ①.
- Remove the carburetor clamp screw ②.

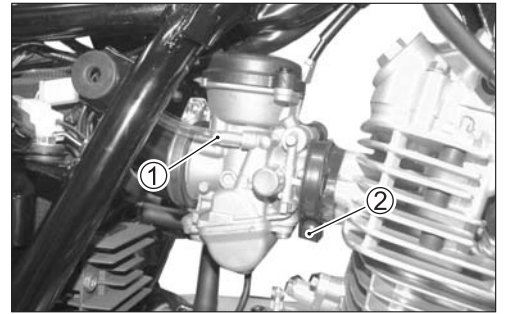

- Remove the throttle cable ③.
- Remove the fuel hose ④.
- Remove the carburetor.

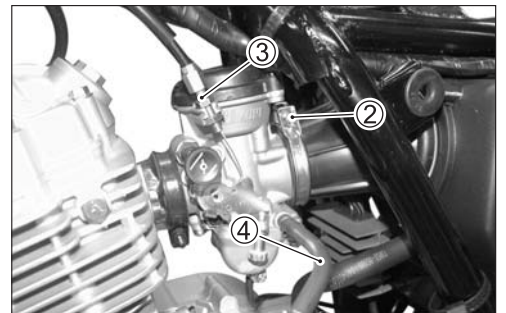

- Remove the carburetor diaphragm cover.



- Remove the spring, diaphragm and piston.



- Remove the float chamber body.



- Remove the float pin screws.
- Pull out the float pin and remove the float and needle valve.

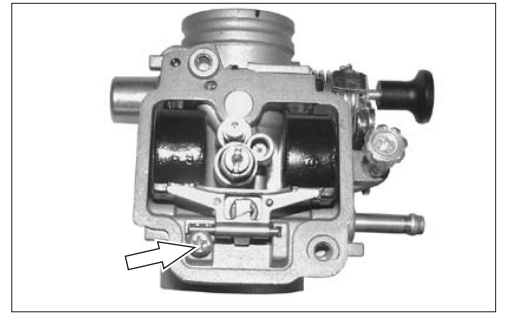

- Remove the main jet (A).
- Remove the Bubbling jet (B).
- Remove the idle jet (C).

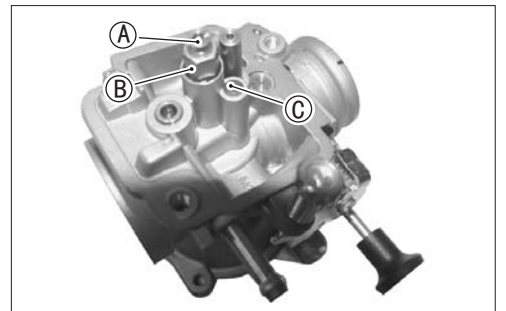

NEEDLE VALVE INSPECTION

If foreign matter is caught between the valve seat and the needle, the gasoline will continue flowing and cause it to overflow.

Clean the float chamber and float parts with gasoline, if the needle is worn as shown in the illustration, replace it together with a valve seat. Clean the fuel passage of the mixing chamber with compressed air.

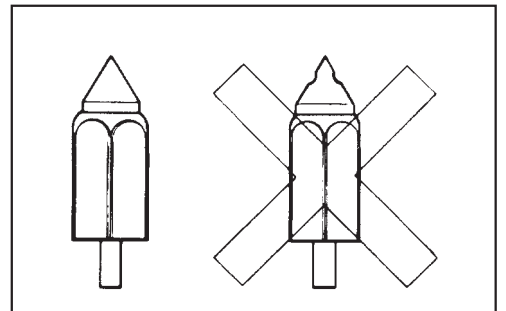

REMOUING AND REASSEMBLY

Reassemble the carburetor by reversing the sequence of disassembling steps.

- When installing the floating chamber, make sure to fit the seal ring correctly.

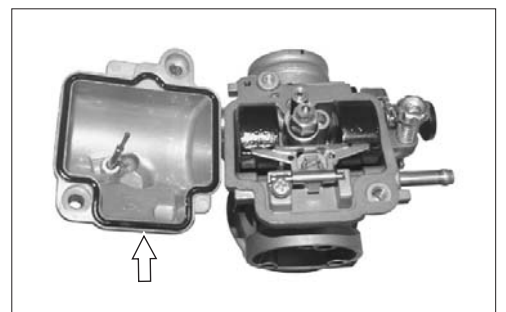

⚠ CAUTION

Replace the O-ring with a new one when installing the float chamber.

REMOUNTING

Remount the carburetor by reversing the sequence of removal steps, and following adjustments and inspection are necessary after remounting the carburetor.

THROTTLE CABLE PLAY

Adjust the throttle cable play $\text{\textcircled{A}}$ to be 0.5-1.0 mm.

- Adjust the throttle cable play as follows.
- Slide the boot, loosen the lock nut $\text{\textcircled{1}}$ of the throttle pulling cable, turn the adjuster $\text{\textcircled{2}}$ clockwise or counterclockwise until the throttle cable play (at the throttle grip) is between 0.5-1.0 mm.
- Tighten the lock nut $\text{\textcircled{1}}$ after adjusting the play,
- Recheck that handlebar movement does not raise the engine idle speed and that the throttle grip returns smoothly and automatically.

DATA Throttle cable play: 0.5~1.0 mm

IDLING ADJUSTMENT

⚠ WARNING

If engine running is needed in work, be sure to keep the work area well ventilated. Do not run engine in an closed space. In engine exhaust gas, there is carbon monoxide that leads to loss of consciousness or leads to death.

Engine running is allowable only at a well ventilated place or in an enclosure with exhaust gas discharge system.

⚠ CAUTION

Idle air screw is factory-installed and set. Adjustment is not necessary unless carburetor needs to be disassembled for inspection or screws need to be replaced. For accurate adjustment, a ten-minute engine preheating is necessary.

- Turn in the idle air screw until it lightly seats, then back it out the pre-set turns.

DATA Pre-set: 2, 5/8 turns back

- Start the engine, preheat it under idle running condition.
- Adjust the idle speed by means of the pilot screw.

DATA Engine idle speed: 1 500 100 r/min

- Slowly and repeatedly adjust the idle air screw to obtain maximum engine speed.
- Adjust idle speed to specified value by means of pilot screw. In case of unstable engine running, repeat till the engine running is easy and stable.

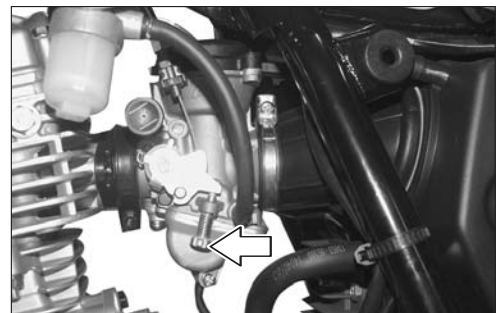
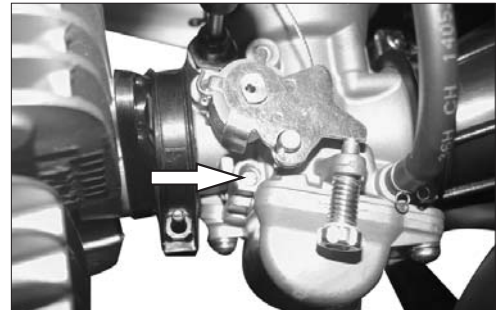
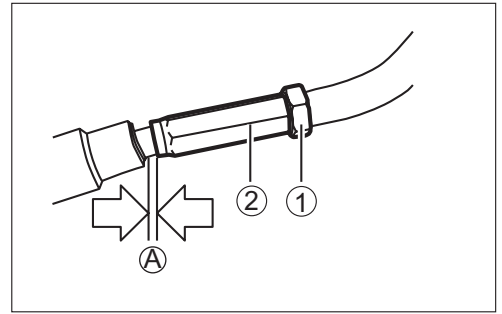

LUBRICATION SYSTEM

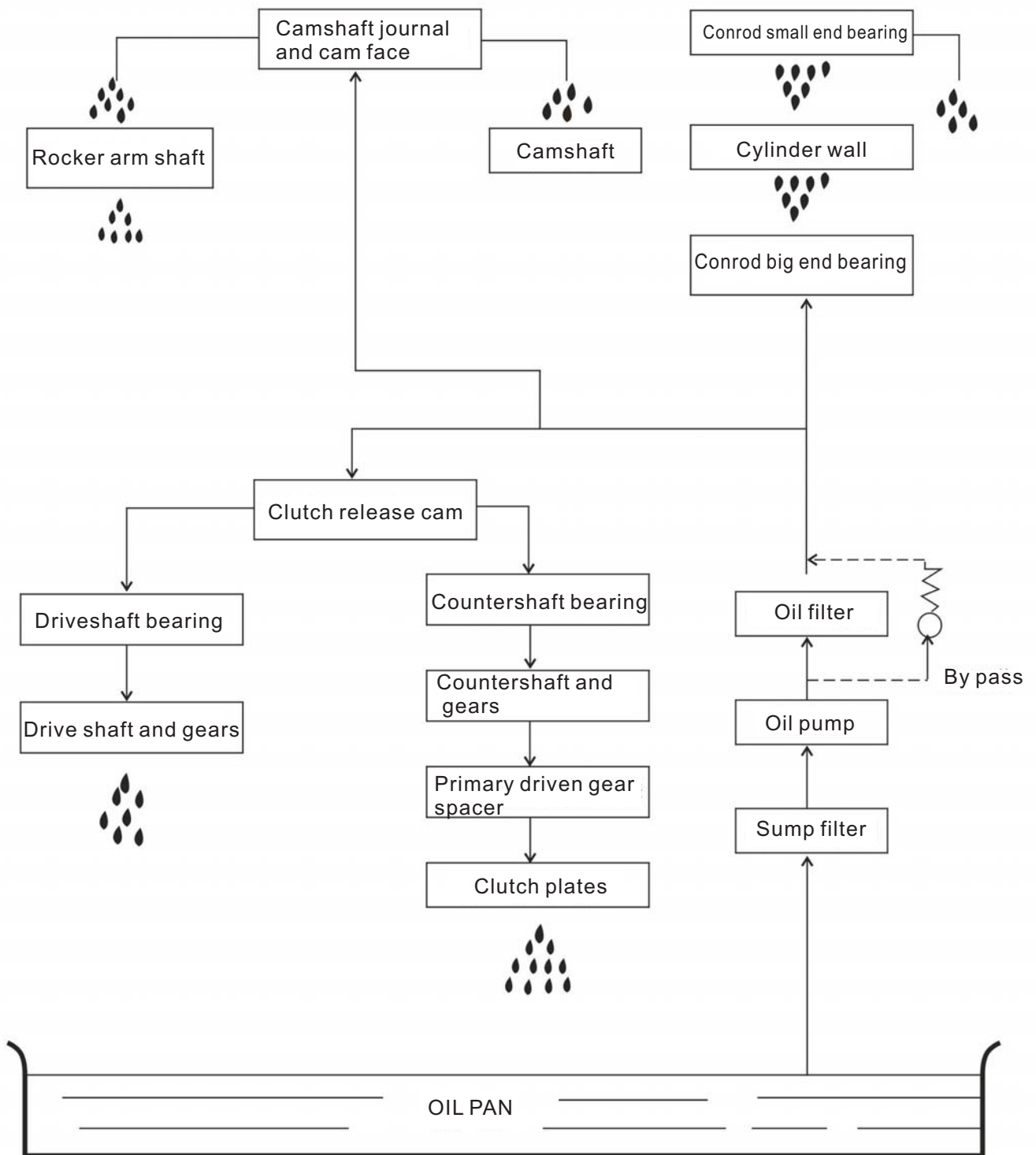

CHASSIS

CONTENTS

FRONT WHEEL	5-1
FRONT ABSORBER	5-6
STEERING STEM	5-12
FRONT BRAKE	5-18
REAR WHEEL AND REAR BRAKE	5-24
REAR ABSORBER AND REAR SWING ARM	5-30

FRONT WHEEL CONSTRUCTION

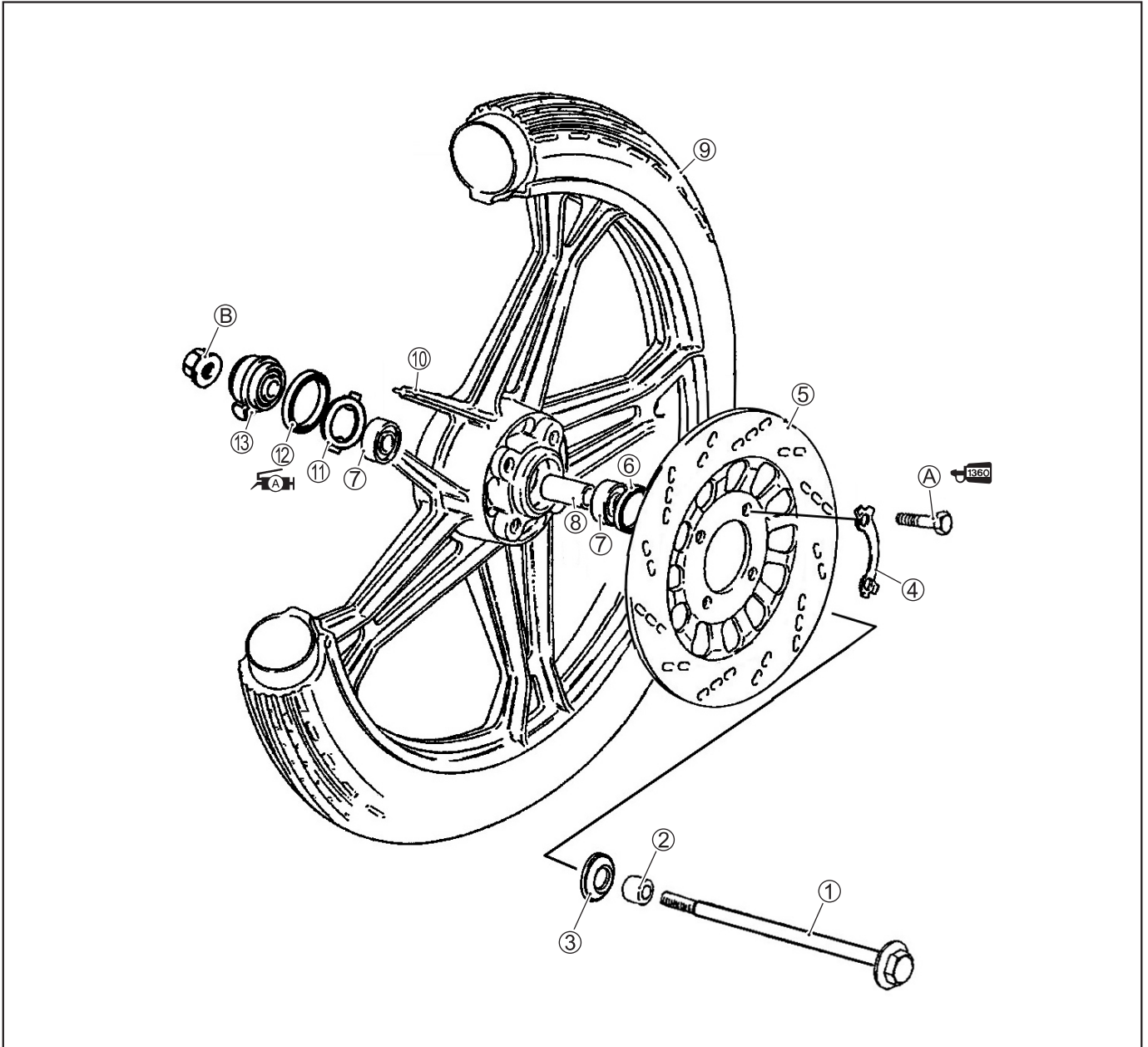

①	Front axle	⑨	Front tire
②	Spacer	⑩	Front rim
③	Dust seal	⑪	Speedometer gear driver
④	Washer	⑫	Oil seal
⑤	Brake disc	⑬	Speedometer gear box
⑥	Oil seal	Ⓐ	Brake disc bolt
⑦	Roller bearing	Ⓑ	Front axle nut
⑧	Spacer		



Item	N•m	kgf•m
Ⓐ	18-28	1.8-2.8
Ⓑ	36-52	3.6-5.2

REMOVAL AND DISASSEMBLY

- Support the motorcycle by the center stand.
- Disconnect the front brake and speedometer cable ①.
- Remove the front axle nut ②, take off the front wheel ③.

⚠ CAUTION

Do not operate the front brake lever when removing the front wheel.

- Remove the speedometer gearbox assembly ④.

- Remove the front axle spacer and front wheel assembly dust seal ⑤.

- Flatten the lock washer, remove the brake disc bolts, take off the brake disc ⑥.

- Remove the oil seal ⑦ on both sides with the special tool.

TOOL 09913-50121: Oil seal remover

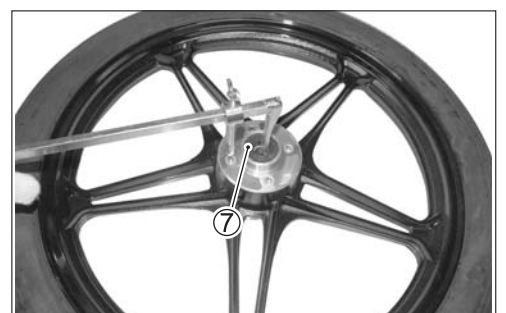
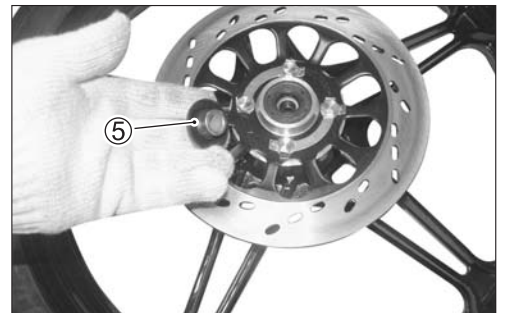
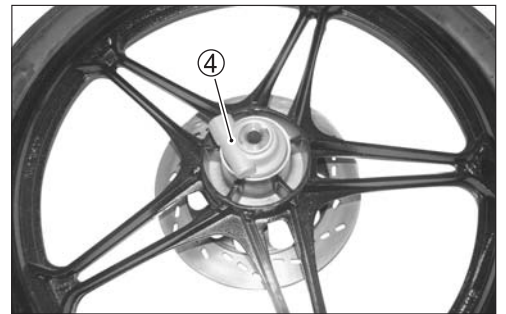
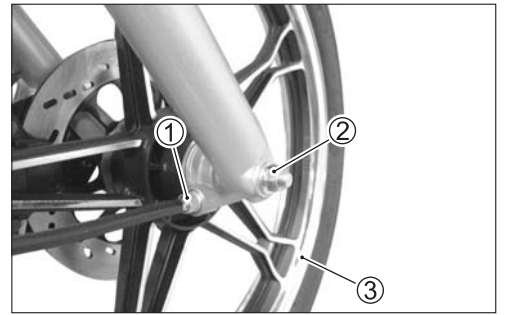

- Remove the bearings ⑧ on both sides with the special tool, take off the spacer.

TOOL 09921-20240: Bearing remover tool

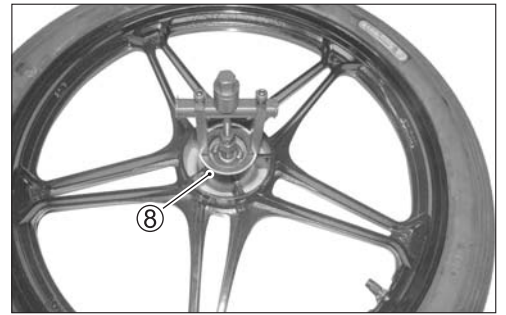

INSPECTION

OIL SEAL

Inspect the oil seal for wear or damage, replace the oil seal if there are any defects.

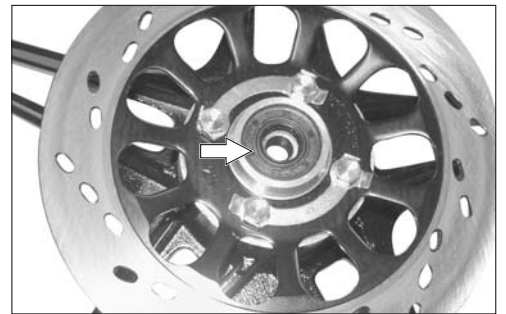

FRONT WHEEL AXLE

- Using the special tools, check the axle shaft for runout and replace it if the runout exceeds the limit.

TOOL 09900-20606 : Dial gauge (1/100)
 09900-20701 : Magnetic stand
 09900-21304 : V-block (100mm)

DATA Wheel axle runout:
 Service limit: 0.25 mm

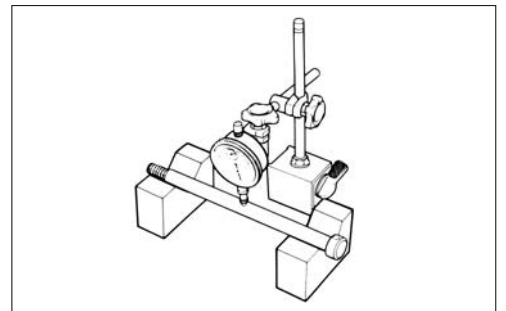

WHEEL RIM

Make sure that the wheel rim runout does not exceed the service limit when checked as shown. An excessive amount of runout is usually due to loose spokes or a bent wheel rim. If properly tightening the spokes will not correct the runout, replace the wheel rim.

DATA Wheel rim runout:
 Service limit: 2.0 mm

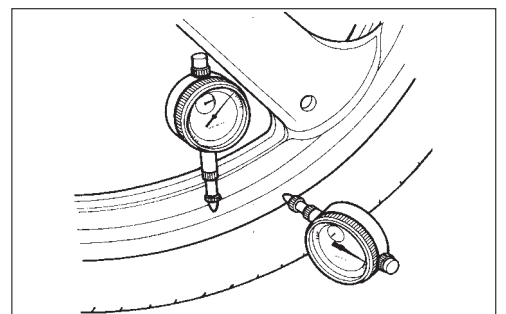

WHEEL BEARING

Inspect the play of the wheel bearings inner race by hand while fixing it in the wheel hub.
 Rotate the inner race by hand to inspect whether abnormal noise occurs or rotating smoothly.
 Replace the bearing if there is something unusual.

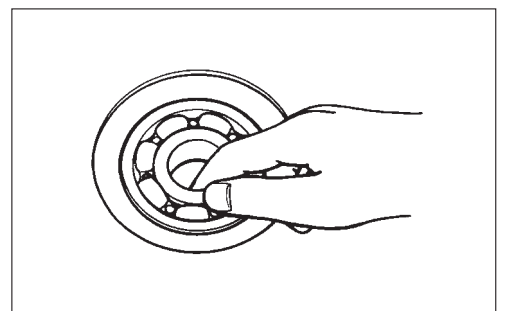

REASSEMBLY

Reassemble and remount the front wheel in reverse order of removal. Pay special attention to the following points.

WHEEL BEARING

- Apply Super Grease "A" to bearings before reassembly.

 **99000-25010: Super grease "A"**

- Install left wheel bearing ① first, then install the spacer ② and right wheel bearing ③ with the special tool and removed wheel bearings ④.

 **09924-84521: Bearing installer**

CAUTION

The sealed cover of the bearing must face outside.

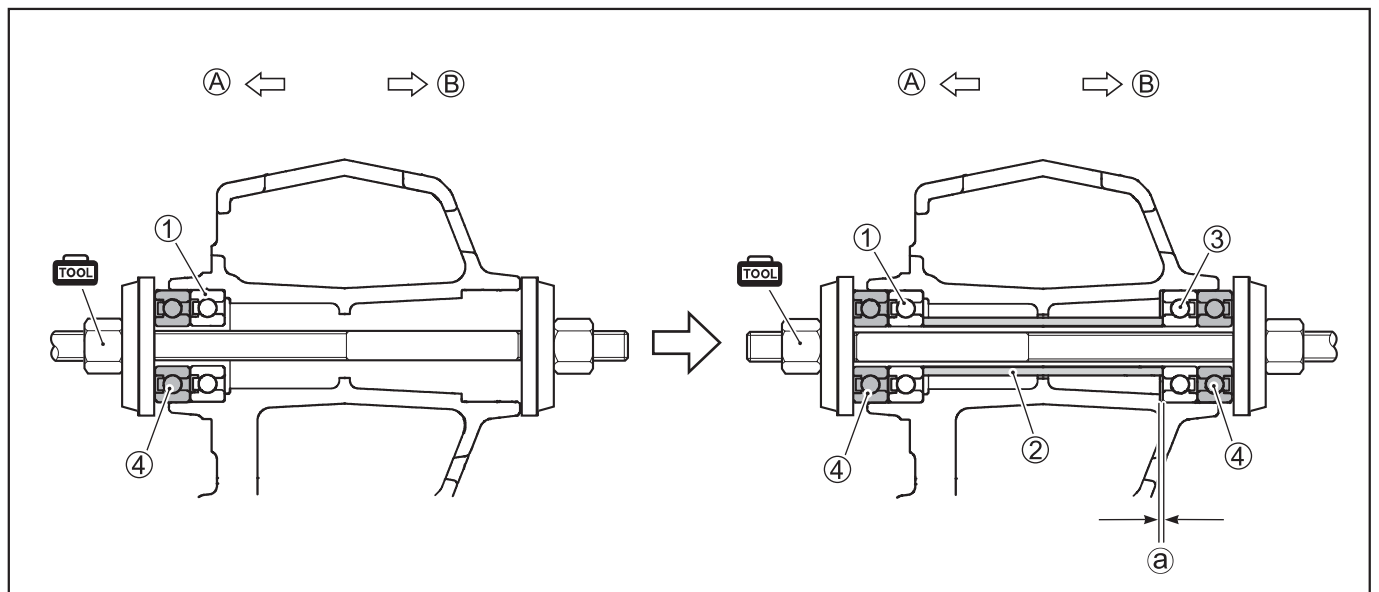
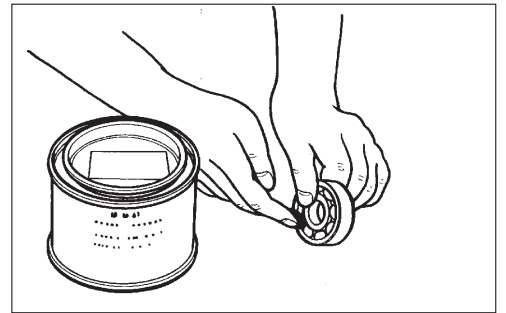

① Left bearing	③ Right bearing	Ⓐ LH	ⓐ Clearance
② Spacer	④ Removed wheel bearing	Ⓑ RH	

DUST SEAL

- Apply the Super Grease A to the dust seal lips.
- Install the new dust seals using the special tool.

 **99000-25010 : Super grease "A"**

 **09913-70210 : Bearing installing set (10-75Φ)**



BRAKE DISC

- Make sure that the brake disc is clean and free of any greasy matter.
- Install the brake disc, tighten to the brake disc bolts to the specified torque.



Front brake disc bolt: 18~28 N•m

- Bend the lock washer to the brake disc bolt.

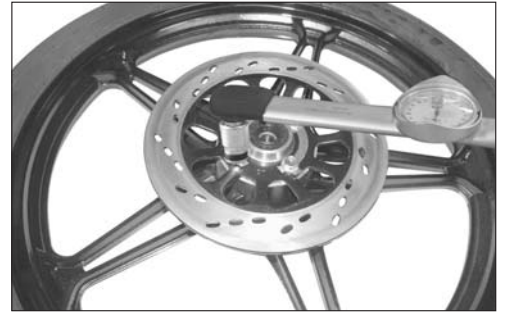

SPEEDOMETER GEAR BOX

- Before installing the speedometer gear box, apply Super Grease A to it, then install it on the wheel.



99000-25010: Super grease "A"



FRONT AXLE SHAFT

- Install the front wheel and front axle, tighten the front axle nut to the specified torque.



Front axle nut: 36-52 N•m

CAUTION

When tightening the front axle, check to be sure that speedometer gear box is in the position shown.

WARNING

After installing the front wheel, pump the brake lever until the pistons push the pads correctly.



FRONT ABSORBER CONSTRUCTION

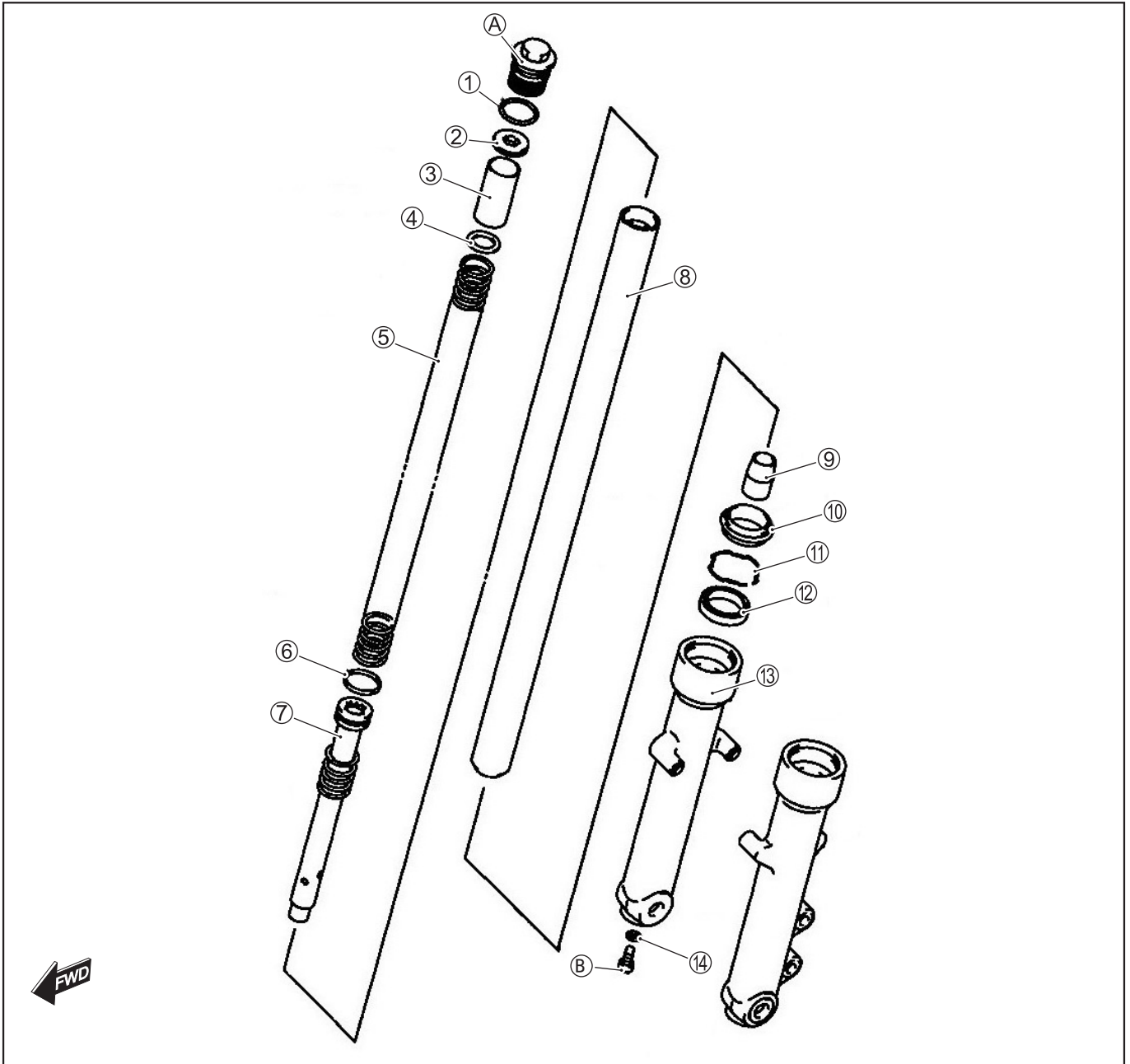

①	O-ring	⑨	Oil lock piece
②	Plug	⑩	Oil seal
③	Tube	⑪	Oil seal stopper ring
④	Washer	⑫	Oil seal
⑤	Rebound spring	⑬	Outer tube
⑥	Ring	⑭	Seal ring
⑦	Damper rod	Ⓐ	Front axle pinch bolt
⑧	Inner tube	Ⓑ	Damper rod bolt



ITEM	N•m	kgf•m
Ⓐ	35-55	3.5-5.5
Ⓑ	20-26	2.0-2.6

REMOVAL AND DISASSEMBLY

- Remove the front wheel (refer to page 5-2).
- Remove the two bolts and dismount the front caliper ①.

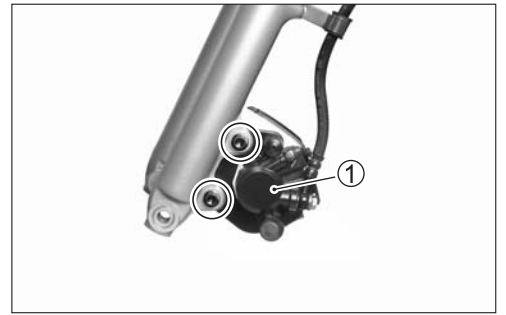

- Remove the four bolts and take off the front fender ② .

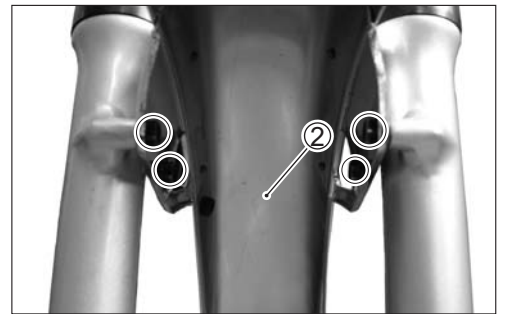

- Remove the four handlebar holder clamp bolts, take off the handle bar ③, then remove the two front absorber cap bolts.



- Remove the decoration plate.
- Loosen the lower bracket clamp bolts, put down the left and right front absorbers.



- Remove the cap bolt and draw out the spacer and absorber spring.

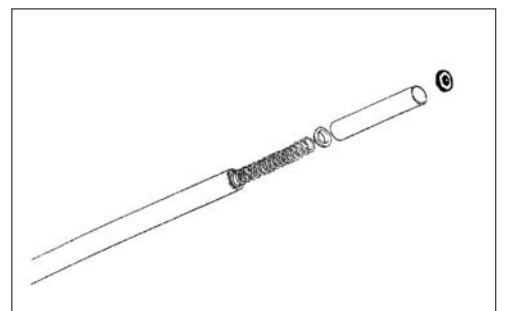

- Invert the absorber and stroke it several times to remove the oil.

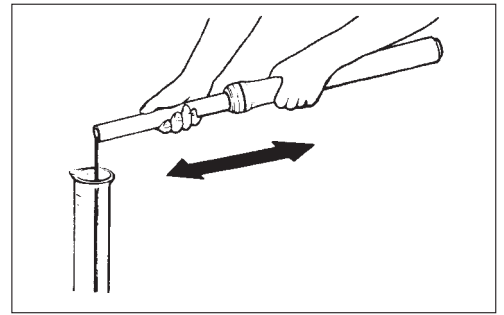

- Remove the damper rod bolt by using the special tools and hexagon wrench.

TOOL 11F14-010: Front absorber tools

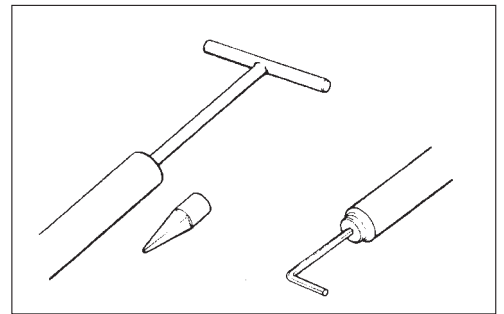

- Remove the oil lock piece and damper rod with rebound spring.
- Separate the inner tube from the outer tube.

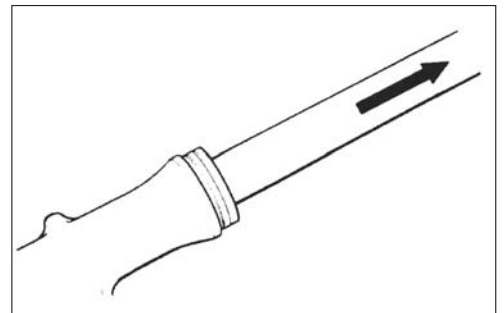

- Remove the stopper ring.

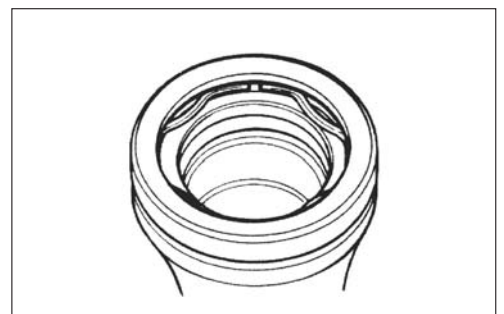

- Remove the oil seal by using the special tool.

TOOL 09913-50121: Oil seal remover

CAUTION

The oil seal removed should be replaced with a new one.

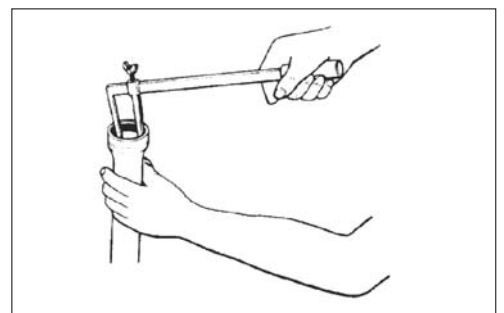

INSPECTION

DAMPER ROD RING

- Inspect the damper rod ring for wear and damage.

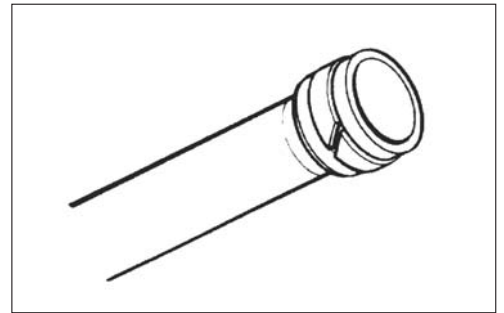

INNER TUBE AND OUTER TUBE

- Inspect the inner tube and outer tube sliding surface for any scuffing or flaws.

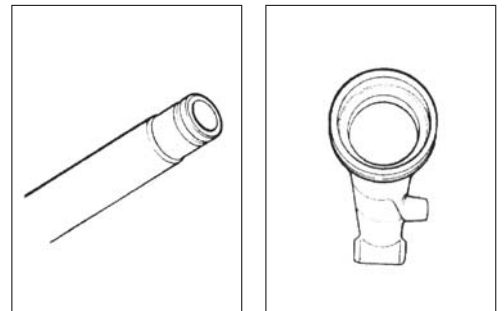

SPRING

- Measure the spring free length. If it is shorter than the service limit, replace it.

DATA Fork spring free length limit: 385.5 mm

* **Cleaning:** clean the parts with solvent and blow dry.

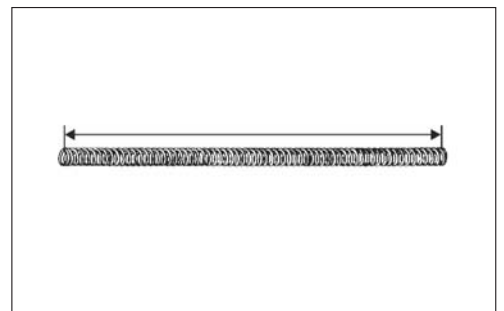

REMOUNTING

Remounting the front fork in the reverse order of removal, pay attention to the following points:

DAMPER ROD BOLT

- Apply Bond No. 4 and Thread Lock Cement to the damper rod bolt and tighten the bolt by using the hexagon wrench and special tools.

 **99000-32040: Thread lock "1303"**

 **11F14-010: Front absorber tools**

 **Damper rod bolt: 20~26 N•m**

 **CAUTION**

Do not reuse the removed O-ring.

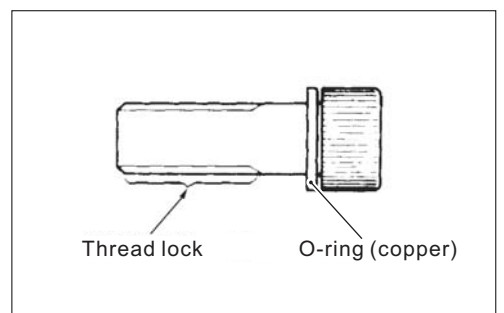

OIL SEAL

- Install the oil seal to the outer tube by using the special tool as shown.

TOOL 09940-50112: Absorber oil seal installer

CAUTION

Apply Super Grease lightly on the oil seal lip.

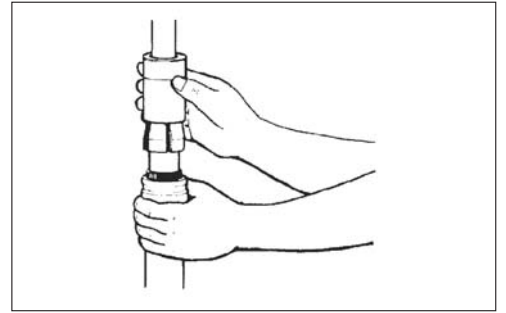

ABSORBER OIL

- Pour the specified absorber oil into the inner tube.

DATA Front absorber oil capacity (each leg): 168±3 ml

FORK Absorber oil type: # 32

- Hold the front absorber vertical and adjust the absorber oil level with the special tool.

CAUTION

When adjusting the absorber oil level, compress the inner tube fully without the absorber spring.

DATA Absorber oil level: 166 mm

TOOL 09943-74111: Front absorber oil level gauge

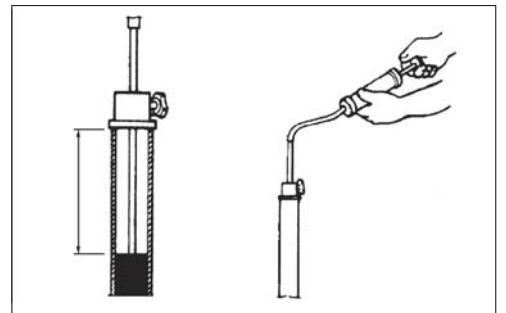
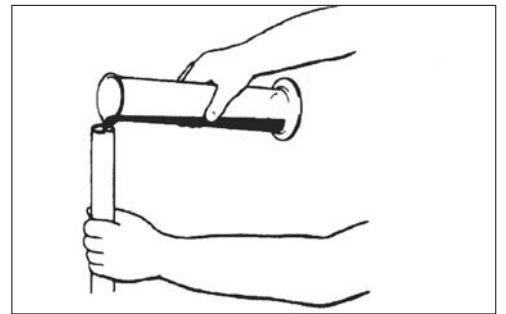

FRONT ABSORBER SPRING

- When installing the front fork spring, the close pitch end should position upside.

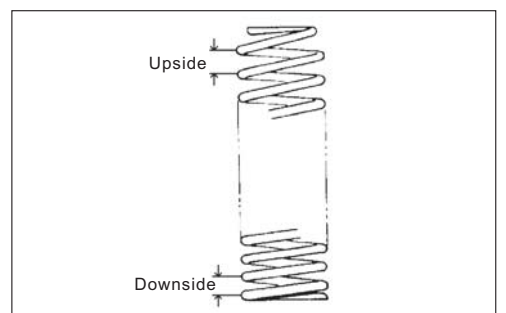

FRONT ABSORBER INNER SCREW PLUG

- Install the front absorber inner screw plug and tighten it.



REASSEMBLY

Reassemble the front absorbers in the reverse order of removal. Pay attention to the following points:

- Apply a small quantity of absorber oil to the O-ring ① on the front absorber.

 **Absorber oil type: #34**

- Install the front absorbers to the upper and lower bracket, tighten the front absorber cap bolts ② to the specified torque.

 **Front absorber cap bolts: 35-55 N•m**

- Tighten the front absorber lower bracket clamp bolts ③ to the specified torque.

 **Lower bracket clamp bolt : 25-35 N•m**

- Install the front caliper, tighten the mounting bolts to the specified torque.

 **Lower bracket clamp bolt: 18-28 N•m**

- Install the front wheel. (Refer to page 5-4)

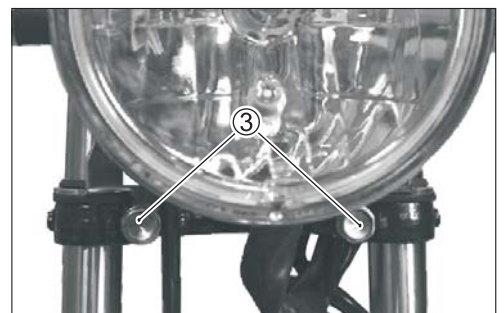
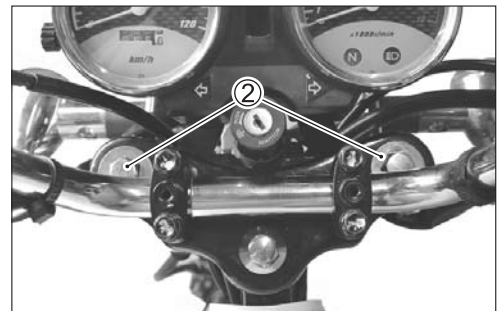

STEERING STEM CONSTRUCTION

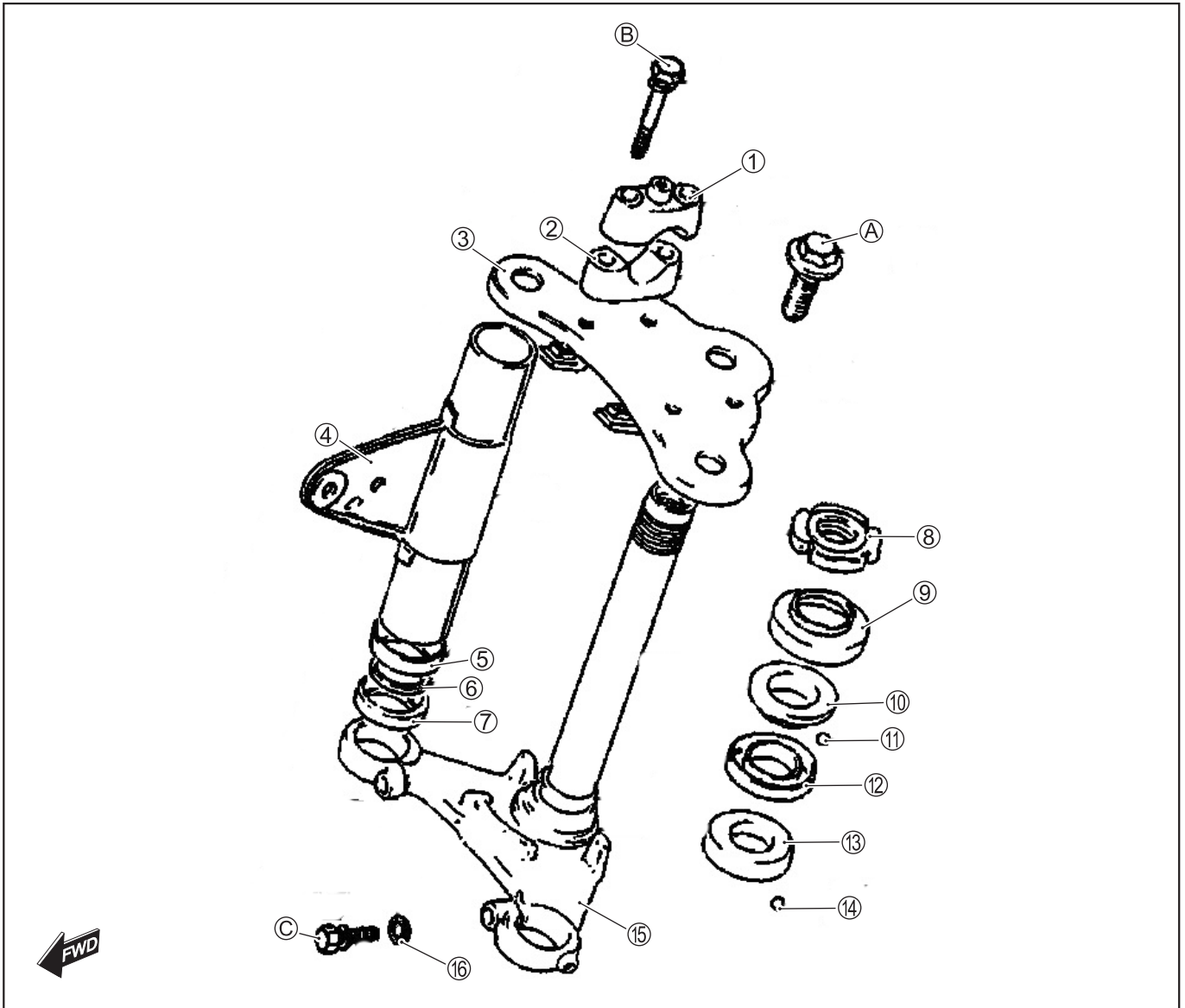

①	Steering stem upper bracket	⑪	Ball
②	Steering stem lower bracket	⑫	Upper bearing inner race
③	Upper bracket	⑬	Lower bearing inner race
④	Headlight right bracket	⑭	Ball
⑤	Spacer	⑮	Lower bracket
⑥	Dust seal	⑯	Washer
⑦	Headlight bracket damper	Ⓐ	Steering stem bolt
⑧	Steering stem nut	Ⓑ	Handlebar clamp bolt
⑨	Dust seal	Ⓒ	Lower bracket clamp bolt
⑩	Upper bearing outer race		



ITEM	N•m	kgf•m
Ⓐ	35~55	3.5~5.5
Ⓑ	12~20	1.2~2.0
Ⓒ	25~35	2.5~3.5

REMOVAL

- Remove the front wheel. (Refer to page 5-2)
- Remove the front absorber. (Refer to page 5-6)
- Remove the two screws and take off the headlight.

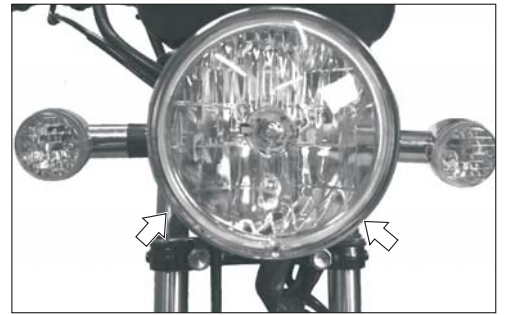

- Disconnect the couplers and lead wires.



- Remove the lead wires from the headlight housing.
- Remove the two bolts and take off the headlight housing.



- Remove the two nuts and take off the turn signal lights, right and left.
- Loosen the lower bracket bolts.

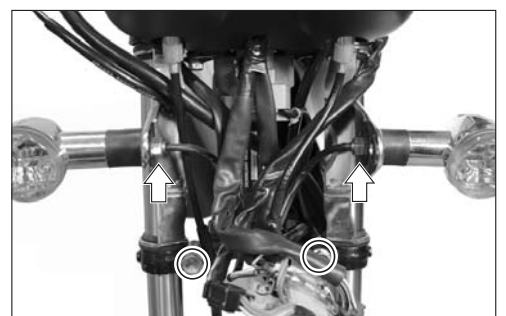

- Remove the tachometer cable.

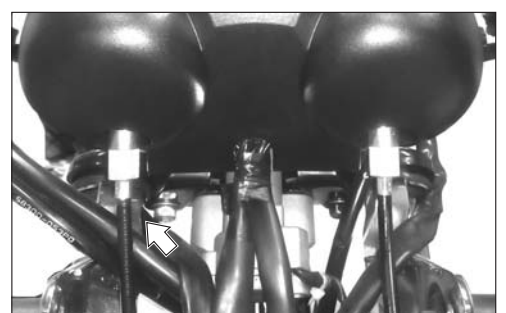

CHASSIS

- Remove the two bolts and take off the dashboard assembly.



- Remove the ignition switch cover.
- Remove the handlebar holder clamp bolts, take off the handlebar ①.

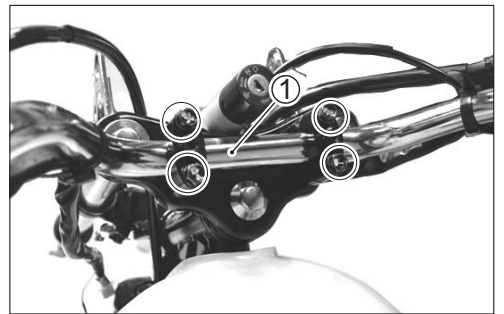

- Remove the front absorber cap bolts and steering stem nut, take off the upper bracket.
- Take off the front absorbers.



- Remove the steering stem nut and draw out steering stem.

TOOL 09940-14911: Steer stem nut wrench

CAUTION

Hold the steering stem by hand to prevent from falling.



- Remove the steering stem dust seal and upper bearing outer race.



- Remove the upper and lower steel balls.

DATA Number of balls:

Upper: 22 pcs

Lower: 18 pcs

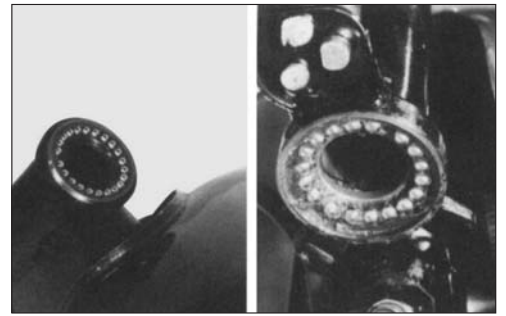

- Remove the outer race fitted on the steering stem. This can be done with a chisel.

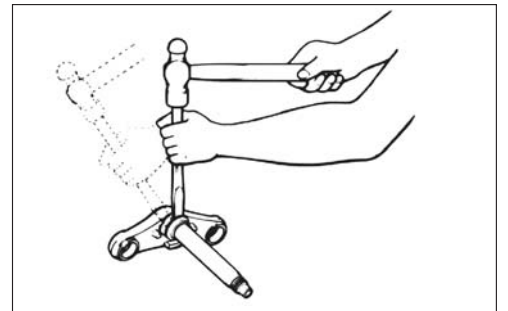

- Draw out the two inner races fitted to the top and bottom ends of the head pipe with the special tool.

TOOL 09941-54911: Bearing remover
09941-74910: Steering bearing installer

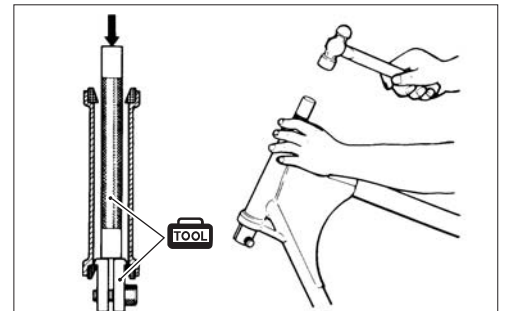

INSPECTION

- Inspect and check the removed parts for the following abnormalities.

- Handlebars distortion.
- Handlebars clamp wear.
- Race wear and brinelling.
- Worn or damaged steel balls.
- Distortion of steering stem.

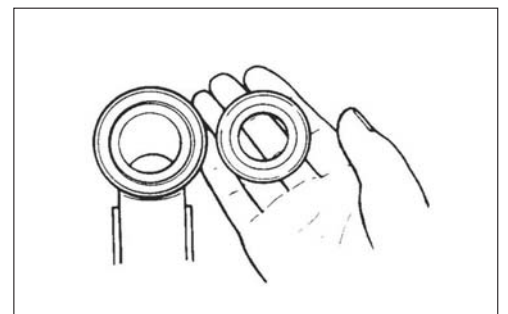

REASSEMBLY

Reassemble and remount the steering stem in the reverse order of removal, and carry out the following steps:

INNER RACES

- Press in the upper and lower inner races with a special tool.

 **09940-34513: Steering race installer**

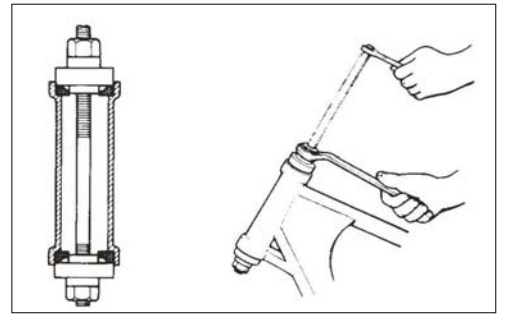

OUTER RACE

- Apply grease on the new lower oil seal.
- Press in the lower outer race with the special tool.

 **99000-25010 : Super grease "A"**

 **09941-74910 : Steering bearing installer**

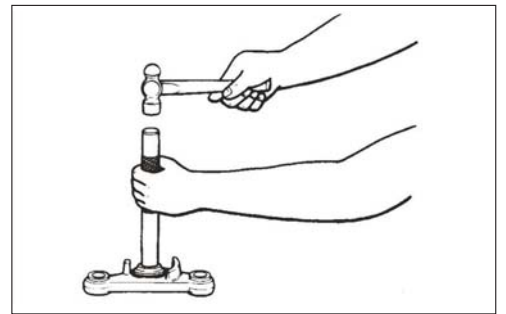

STEEL BALL

- Apply grease to the upper and lower inner races when installing the steel balls.

 **99000-25010 : Super grease "A"**

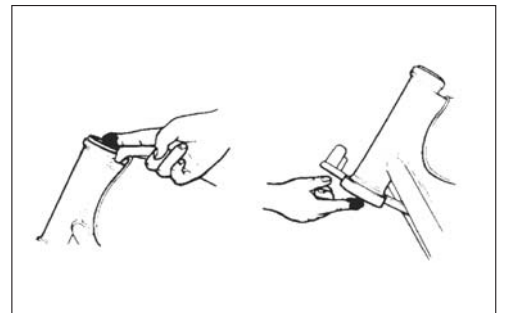

STEERING STEM NUT

- Tighten the steering stem nut to 40-50 N•m by using the special tool.

 **09941-14911: Steering nut socket wrench**

 **Steer stem bolt: 40~50 N•m**



- Turn the steering stem right and left, lock-to-lock, five or six times to "seat" the ball bearings.

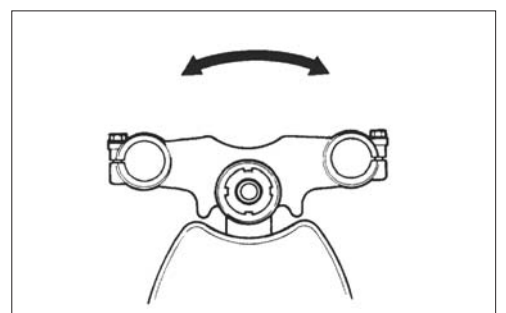

- Turn back the stem nut by 1/4-1/2 turn.

TOOL 09910-60611: Universal wrench

CAUTION

The adjustment will vary from motorcycle to another.

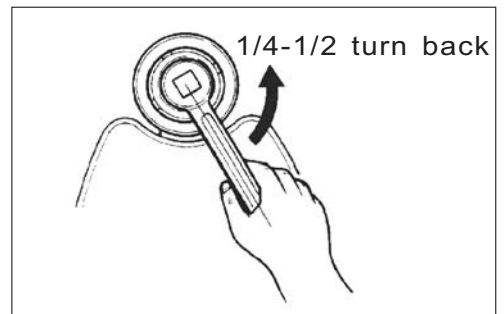

- Tighten the steering stem head bolts to the specified torque.

U **Steer stem bolt: 35~55 N•m**

- Install and tighten the front absorber bolts and the brake caliper bolts. (Refer to page 3-11)

WARNING

After performing the adjustment and installing the steering stem upper bracket, “rock” the front wheel assembly forward and backward to ensure that there is no play and that the procedure was accomplished correctly. Finally check that the steering stem moves freely from left to right with its own weight. If play or stiffness is noticeable, re-adjust the steering stem nut.



HANDLEBAR

- Set the handlebar to match its punched mark to the mating face of the holder.



- Secure the each handlebar clamp in such a way that the clearance **A** ahead of and behind the handlebar should be equalized.

U **Handlebar clamp bolt: 12~20 N•m**

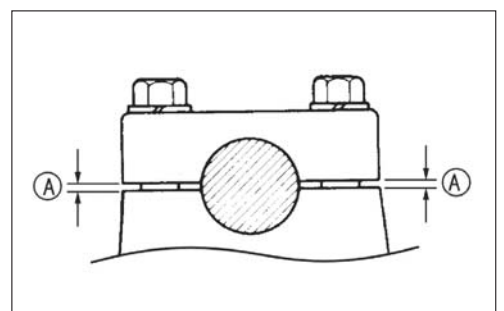

FRONT BREAK CONSTRUCTION

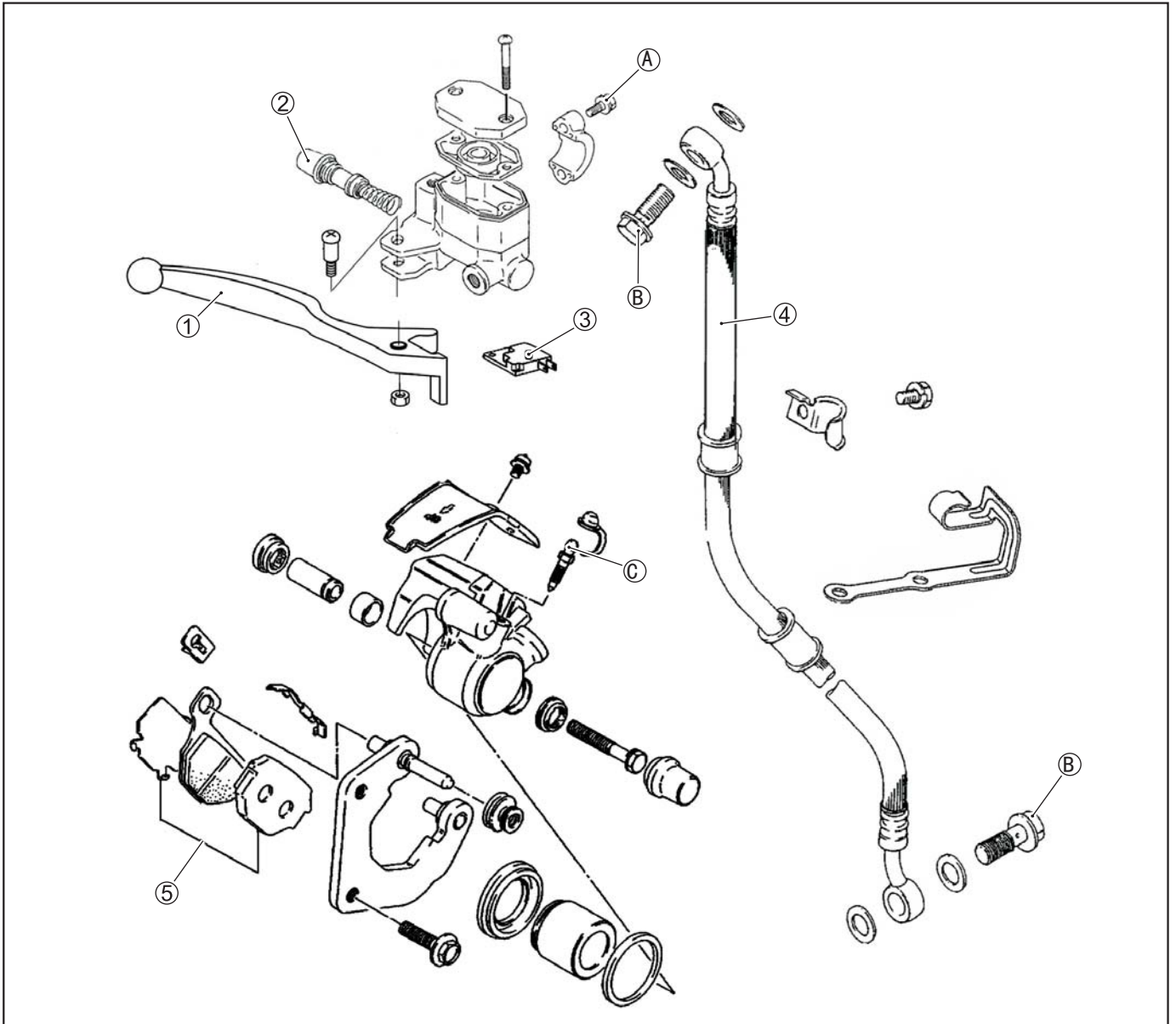

①	Brake lever	⑤	Pad set
②	Piston cup set	Ⓐ	Master cylinder clamping bolt
③	Brake light switch	Ⓑ	Brake hose union bolt
④	Brake hose	Ⓒ	Air bleeder valve



ITEM	N•m	kgf•m
Ⓐ	8-12	0.8-1.2
Ⓑ	20-25	2.0-2.5
Ⓒ	6-9	0.6-0.9

⚠ WARNING

The brake system of this motorcycle is filled with a Suzuki brake fluid. Do not use or mix different types of fluid such as silicone-based and petroleum-based fluid for refilling the system, otherwise serious damage will be caused.

Do not use any brake fluid taken from old or used or unsealed containers. Never re-use the brake fluid left over from the last servicing and stored for long periods.

When storing the brake fluid, seal the container completely and keep away from children.

When replenishing brake fluid, take care not to get dust into fluid.

When washing brake components, use new brake fluid. Never use cleaning solvent.

A contaminated brake disc or brake pad reduces braking performance. Discard contaminated pads and clean the disc with high quality brake cleaner or neutral detergent.

⚠ CAUTION

Immediately and completely wipe off any brake fluid contacting any part of the motorcycle. The brake fluid reacts chemically with paint, plastics and rubber materials, etc., and will damage them severely.

BRAKE PAD REPLACEMENT

- Remove the brake caliper mounting bolts .



- Remove the brake pads mounting bolt and brake pads, replace the brake pads.

⚠ CAUTION

Replace brake pads as a set; otherwise braking performance will be adversely affected.



- Reinstall the new brake pads and the caliper.
- Tighten the caliper mounting bolts to the specified torque.

🔧 Brake caliper mounting bolts: 18~28 N•m

⚠ CAUTION

While installing the brake caliper, push the pistons all the way into the brake caliper.

CALIPER REMOVAL

- Disconnect the brake hose ① from the caliper catch the brake fluid in a suitable receptacle.
- Remove the caliper mounting bolts ② and then take off the caliper.

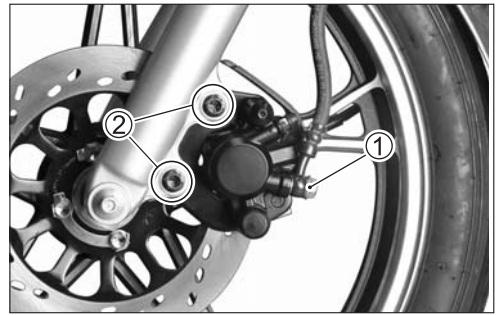

⚠ CAUTION

Never reuse brake fluid left over from the last servicing or stored for a long period of time.
Do not operate the brake lever with the pads removed.

- Remove the brake pads.

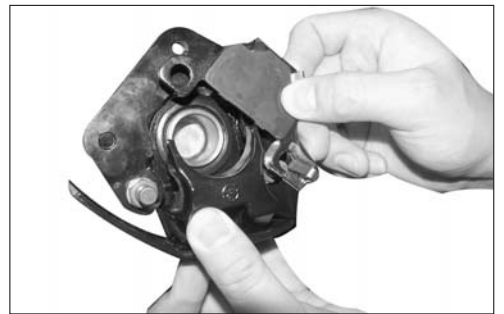

- Place a rag over the piston to prevent popping up. Force out the piston by using air gun.

⚠ CAUTION

Do not use high pressure air to prevent piston damage.

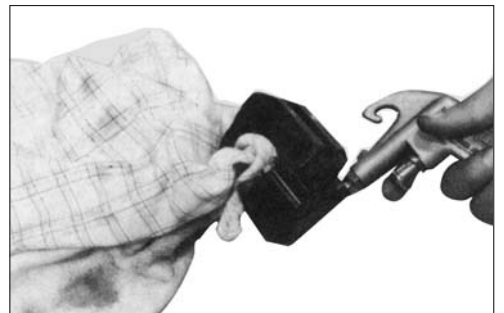

- Remove the piston, piston boot and piston seal.

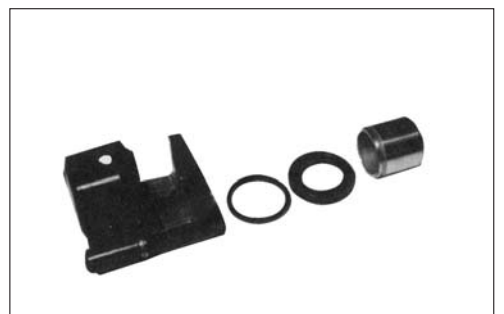

INSPECTION MASTER CLIPER

- Inspect the master cliper bore for any scratches or other damage.

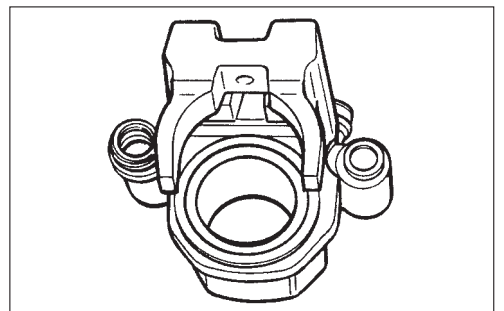

PISTON

- Inspect the piston surface for scratches or other damage.

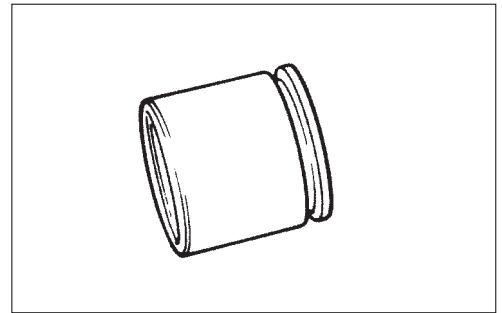

RUBBER PARTS

- Inspect the rubber parts for cracks and damage. If any defects are found, replace the affected parts.

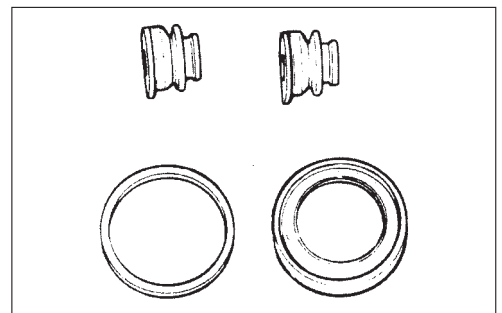

BRAKE DISC

- Visually inspect brake disc for cracks or damage, and measure brake disc thickness with a micrometer.

TOOL 09900-20205: Micrometer (0-25 mm)

DATA Brake disc thickness limit: 3.5 mm



- Measure the brake disc surface runout with a dial gauge.

TOOL 09900-20606: Dial gauge (1/100 mm)
09900-20701: Magnetic stand

DATA Brake disc runout limit : 0.3 mm



REASSEMBLY

Reassemble the cliper in the reverse orders of disassembly and removal, and also carry out the following steps.

⚠ WARNING

**Wash the master cylinder components with fresh brake fluid before reassembly.
Never use cleaning solvent or gasoline to wash them.
Apply brake fluid to the cylinder bore and all internal parts before inserting into the bore.**

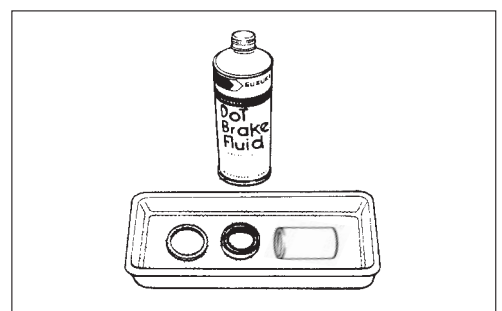

- Tighten the brake hose union bolt to the specific torque.

 **Brake hose union bolt: 20~25 N•m**

- Bleed air from the brake fluid circuit after reassembly the cliper. (Refer to page 2-13)

 **CAUTION**

Brake fluid, if it leaks, will interfere with safe running and immediately discolor painted surfaces. Check the brake hoses for cracks and hose joint for leakage before riding.

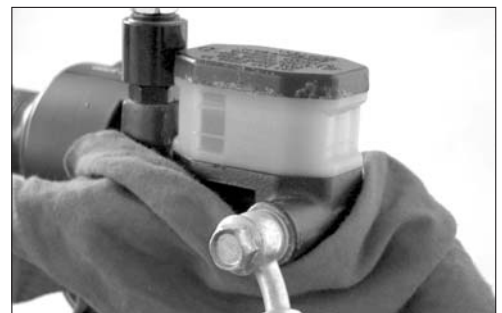
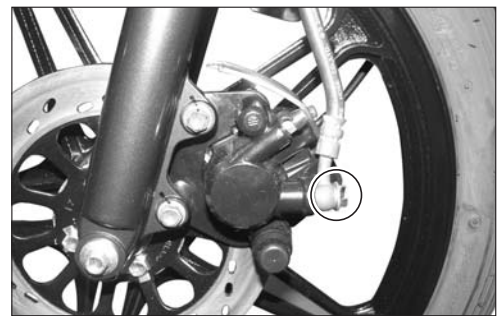

MASTER CYLINDER REMOVAL AND DISASSEMBLY

- Place a cloth underneath the union bolt on the master cylinder to catch spilled drops of brake fluid.
- Unscrew the union bolt and disconnect the brake hose from the master cylinder joint.
- Remove two clamp bolts and take off the master cylinder.

 **CAUTION**

Immediately and completely wipe off any brake fluid contacting any part of the motorcycle. The fluid reacts chemically with paint, plastics, rubber materials, etc. and will damage them severely.



- Remove two fitting screws, and remove the cap and diaphragm.
- Drain the brake fluid.

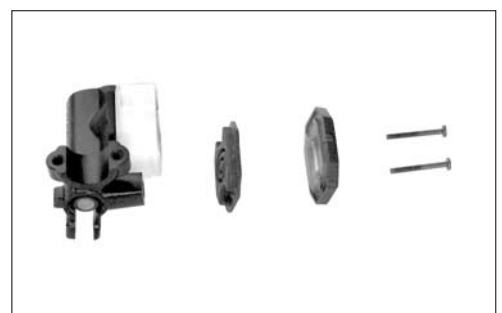

- Remove the dust seal boot.
- Remove the circlip, piston and spring by using the special tool.

 **09900-06108: Snap ring pliers**

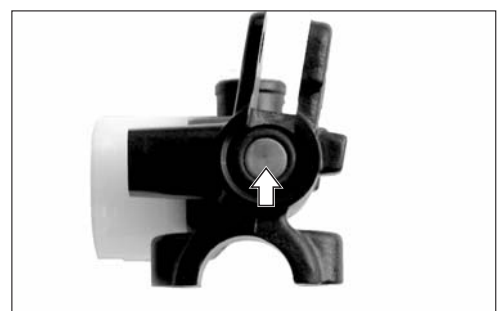

INSPECTION

- Inspect the master cylinder bore for any scratches or other damage.



- Inspect the piston surface for scratches or other damage. Inspect the primary cup, secondary cup and dust seal boot for wear or damage.



REASSEMBLY

Reassemble and remount the master cylinder in the reverse orders of disassembly and removal, and also carry out the following steps:

- Wash the master cylinder components with fresh brake fluid before reassembly.

 **Brake fluid specification: Suzuki brake fluid**

CAUTION

When washing the components, use the specified brake fluid. Never use different types of fluid or cleaning solvents such as gasoline, kerosine, etc. Do not wipe the brake fluid off after washing the components.

Apply brake fluid to the cylinder bore and all internal parts before inserting into the bore.

- When remounting the master cylinder on the handlebars, tighten the clamp bolts for upside as shown first.

- Connect the brake hose, tighten the union bolt to the specified torque.

 **Brake hose union bolt: 20~25 N•m**

- Bleed air from brake system after installing the master cylinder. (Refer to page 2-12)

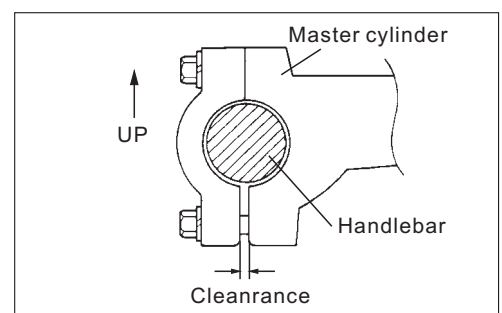
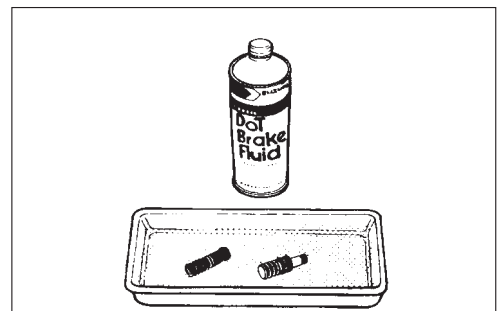

REAR WHEEL AND REAR BRAKE CONSTRUCTION

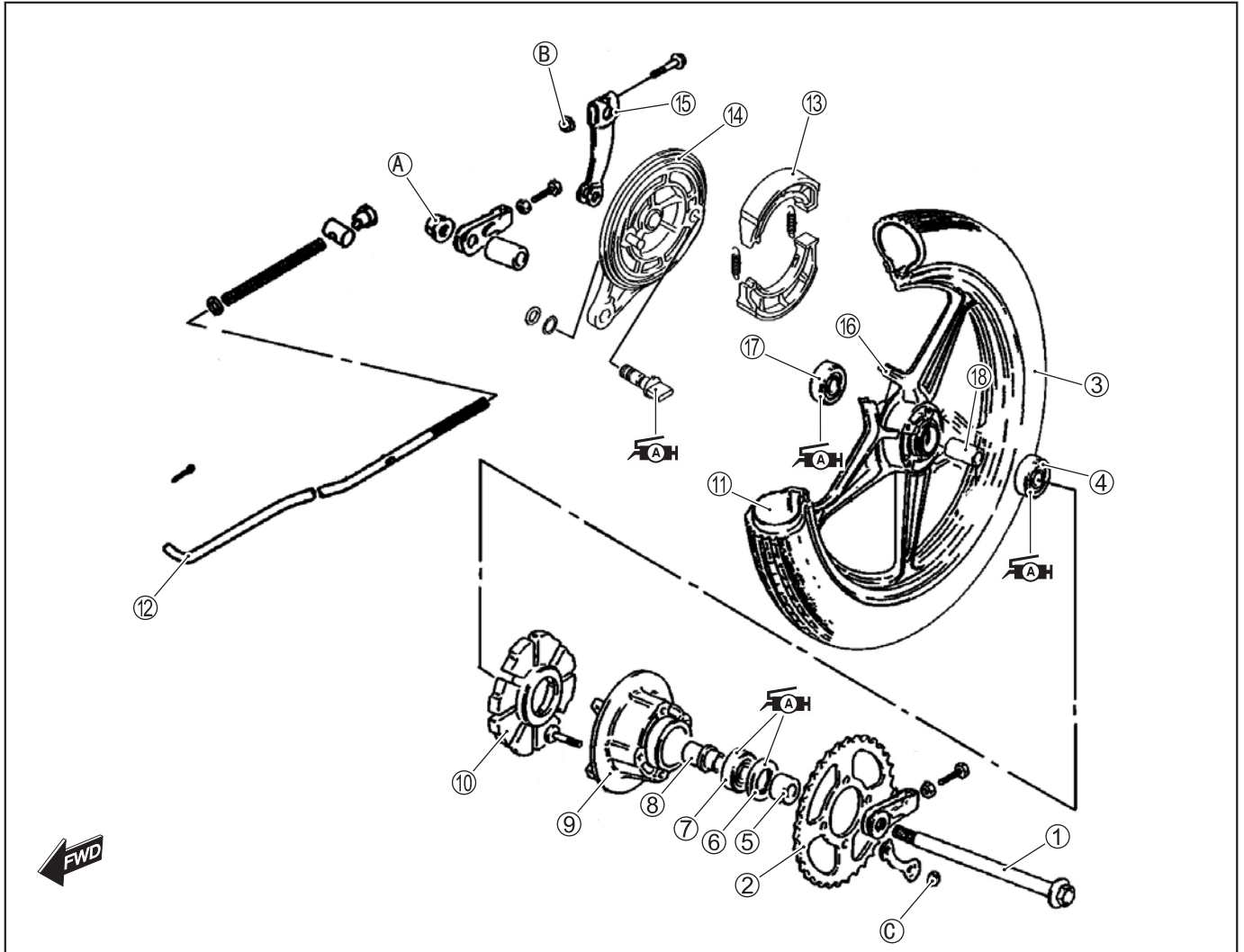

①	Rear axle shaft	⑫	Brake rod
②	Rear sprocket	⑬	Brake shoe
③	Tire	⑭	Rear break anchor panel
④	Roller bearing	⑮	Brake cam lever
⑤	Spacer	⑯	Rear wheel
⑥	Oil seal	⑰	Roller bearing
⑦	Roller bearing	⑱	Spacer
⑧	Rear sprocket drum retainer	(A)	Rear axle nut
⑨	Rear sprocket drum	(B)	Rear brake cam lever nut
⑩	Damper	(C)	Rear sprocket nut
⑪	Inner tire		



ITEM	N•m	kgf•m
(A)	50-80	5.0-8.0
(B)	6-9	0.6-0.9
(C)	18-28	1.8-2.8

REMOVAL AND DISASSEMBLY

- Support the motorcycle by the center stand.
- Remove the rear brake adjuster nut.
- Puff off the cotter pin, remove the torque link nut and bolt.

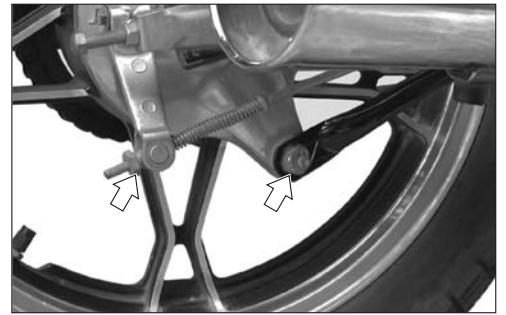

- Remove the rear axle nut.
- Loosen the chain adjuster lock nut and adjuster bolt, right and left.

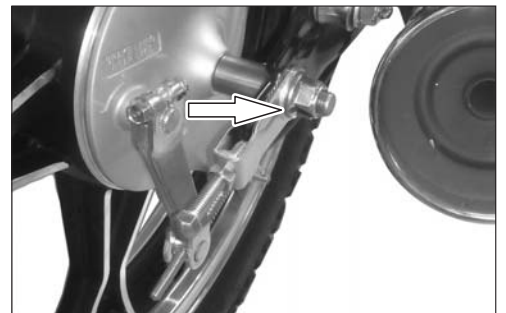

- Draw out the axle shaft and take off the chain from rear sprocket.
- Take off the rear wheel and separate the brake panel from the wheel.



- Flatten the washers and remove the four nuts.
- Separate the rear sprocket and mounting drum from the wheel.



- Remove the oil seal by using the special tool.

 **09913-50121: Oil seal remover**

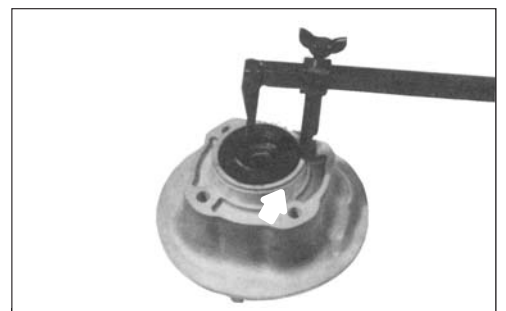

- Remove the cushion from the wheel.



- Remove the right and left side wheel bearings.

⚠ CAUTION

It will be easier to remove the left side bearing first.



- Take off the brake shoes.



- Remove the cam lever nut and bolt.
- Pull off the brake cam, washer, O-ring and cam lever.



**INSPECTION
WHEEL BEARING**

Inspect the wheel bearings for play by hand, Rotate the inner race by hand to inspect whether abnormal noise occurs and it rotates smoothly. Replace the bearing if there are any defects.

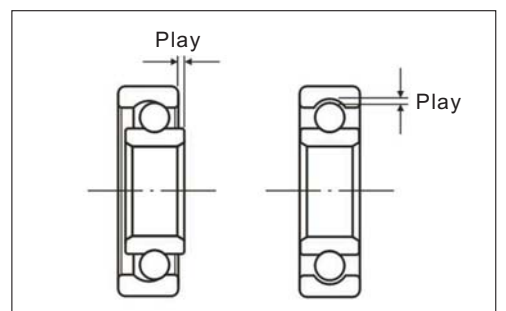

AXLE SHAFT

- Using the special tools, check the axle shaft for runout and replace it if the runout exceeds the limit.

DATA Axle shaft runout limit: 0.25 mm

TOOL 09900-20606: Dial gauge (1/100)
09900-20701: Magnetic stand
09900-21304: V-block

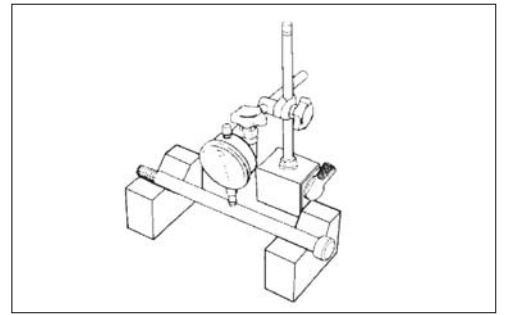

SPROCKET

- Inspect the sprocket teeth for wear. If they are worn as illustrated, replace the sprocket and drive chain.

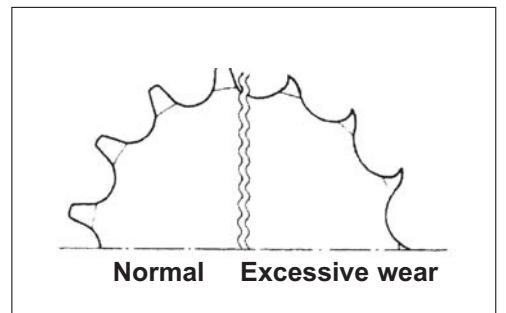

REAR BREAK DRUM

- Measure the brake drum I. D to determine the extent of wear and, if the limit is exceeded by the wear noted, replace the drum. The value of this limit is indicated inside the drum.

DATA Break drum I.D. limit: 130.7 mm

TOOL 09900-20103: Vernier calipers



BRAKE SHOE

- Check the brake shoes and decide whether is should be replaced or not from the thickness of the brake shoe linings.

DATA Brake shoe lining thickness limit: 1.5 mm

TOOL 09900-20103: Vernier calipers

WARNING

Replace the brake shoes as a set, otherwise braking performance will adversely affected.

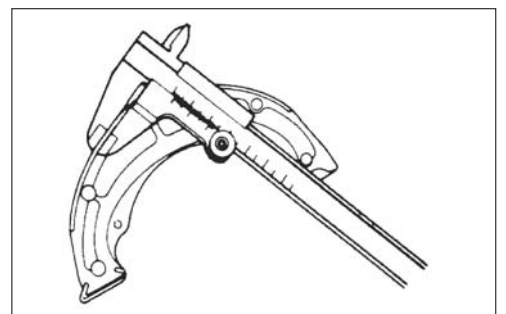

CUSHION

- Inspect the cushion for wear and damage.



REASSEMBLY

Reassemble and remount the rear wheel and the rear brake in the reverse order of disassembly and removal, and also carry out the following steps.

BEARING

- Apply grease to the bearings before installing.

 **99000-25010: Super grease "A"**

- Install the bearings by using the special tool.

 **CAUTION**

First install the bearing for right side.

 **09913-70210: Bearing installer**

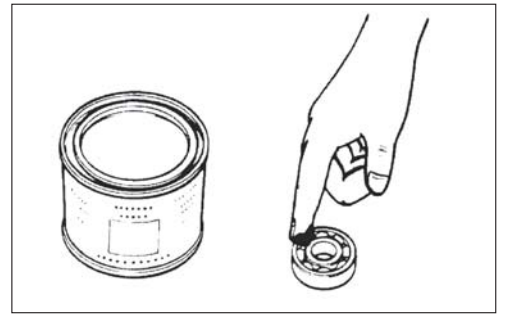

REAR SPROCKET MOUNTING DRUM

- Insert the bearing by using the special tool.

 **09940-53311: Bearing installer**



- Apply grease to the mounting drum as shown.

 **99000-25010: Super grease "A"**



SPROCKET

- Tighten the four nuts to specified torque.

 **Sprocket lock nut: 18~28 N•m**

 **CAUTION**

Do not reuse the removed nuts, replace the nuts with new ones for safe riding.



- Bend the lock washers.



BRAKE CAM

- Apply grease to the brake cam.

 99000-25010: Super grease "A"

WARNING

Be careful not to apply too much grease to the brake cam. If the grease gets on the lining, the brake slippage will result.

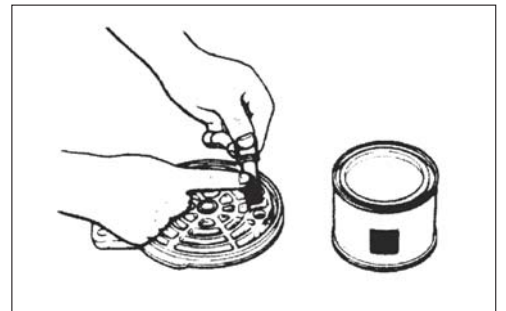

BRAKE CAM LEVER

- Install the brake cam lever and tighten the cam lever nut with specified torque.

 Cam lever bolt: 6~9 N•m



REAR ABSORBER AND REAR SWING ARM CONSTRUCTION

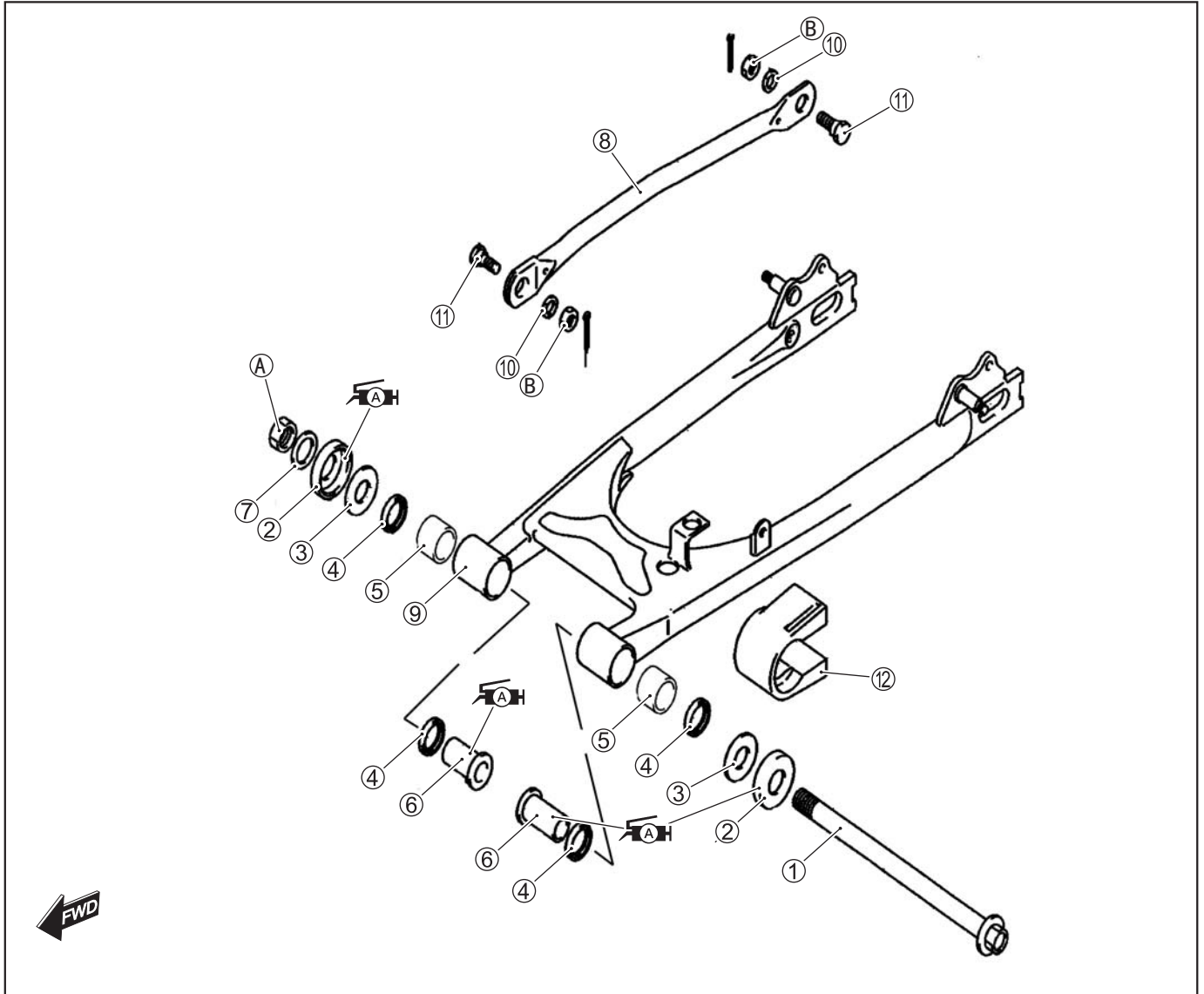

①	Rear swingarm pivot shaft	⑧	Rear torque link
②	Dust seal	⑨	Rear swing arm
③	Thrust washer	⑩	Lock washer
④	Oil seal	⑪	Bolt
⑤	Spacer	⑫	Chain buffer
⑥	Spacer	A	Rear swing arm pivot nut
⑦	Washer	B	Rear torque link nut



ITEM	N m	kgf m
A	50-80	5.0-8.0
B	10-15	1.0-1.5

REMOVAL AND DISASSEMBLY

- Remove the rear wheel (Refer to page 5-24)
- Remove the rear absorber mounting nuts, take off the rear absorber, right and left..
- Remove the chain case mounting screws, take off the chain case.

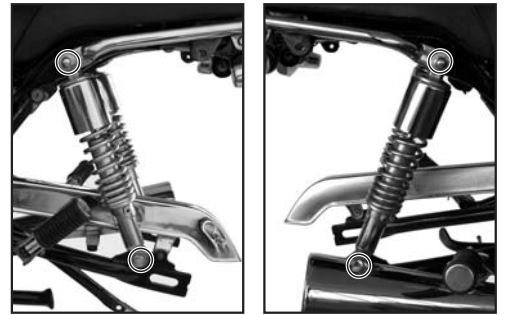

- Remove the swing arm pivot nut and draw out the shaft.
- Remove the swing arm.



- Pull off the cotter pin and remove the nut and bolt.
- Remove the torque link.



- Remove the chain buffer.
- Remove the dust seal covers and draw out the spacers.

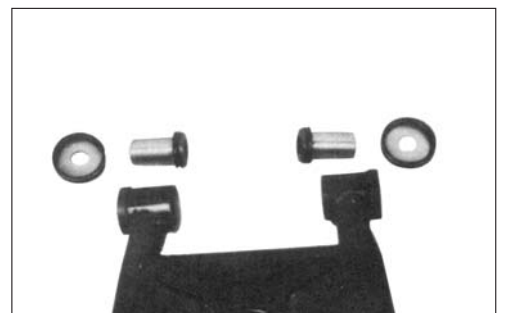

- Draw out the bushings by the special tools.

- TOOL
09923-73210: Bearing remover
09930-30102: Slide shaft

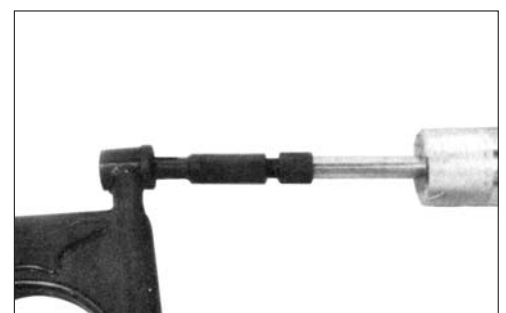

INSPECTION BUSHING

- Inspect the bushing for wear and damage.



SWING ARM PIVOT SHAFT

- Using a dial gauge, check the pivot shaft for runout and replace it if the runout exceeds the limit.

DATA Pivot shaft runout limit: 0.6 mm

TOOL 09900-20606: Dial gauge (1/100)
09900-20701: Magnetic stand
09900-21304: V-block

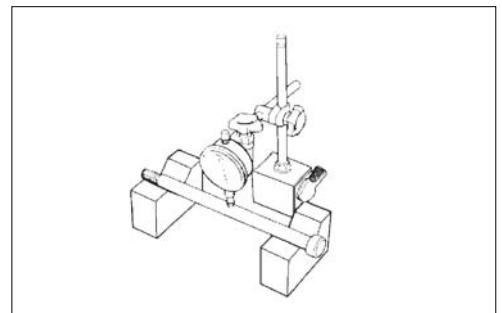

REASSEMBLY

Reassemble and remount the swing arm in the reverse order of disassembly and removal, and also carry out the following steps:

- Force-fit the bushings into the swing arm by using the special tool.

TOOL 09924-84521: Bearing installer set

- Apply grease to the spacer and dust seal cover when installing.
- Insert the swing arm pivot shaft from the left side, and tighten the pivot shaft nut to specified torque.
- Tighten the rear absorber nut to the specified torque.

FAH 99000-25010: Super grease "A"

U Rear pivot shaft nut: 50~80 N•m
Rear absorber nut: 22~35 N•m

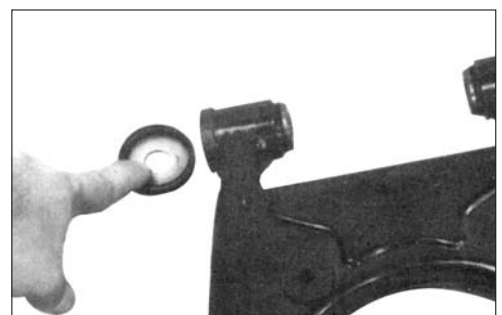
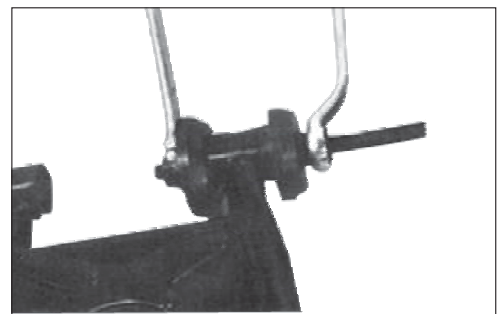

ELECTRICAL

CONTENTS

STARTER SYSTEM	6-1
IGNITION SYSTEM	6-5
CHARGING SYSTEM.....	6-7
DASHBOARD.....	6-11
LIGHTS	6-12
SWITCHES.....	6-12
BATTERY.....	6-15

STARTER SYSTEM

DESCRIPTION

The starter system is shown in the diagram below: namely, the starter motor, starter relay, starter button, clutch switch, ignition switch and battery.

Depressing the starter switch (on the right handlebar switch box) energizes the relay, causing the contact points to close which connects the starter motor to the battery. The motor draws about 70 amperes to start the engine.

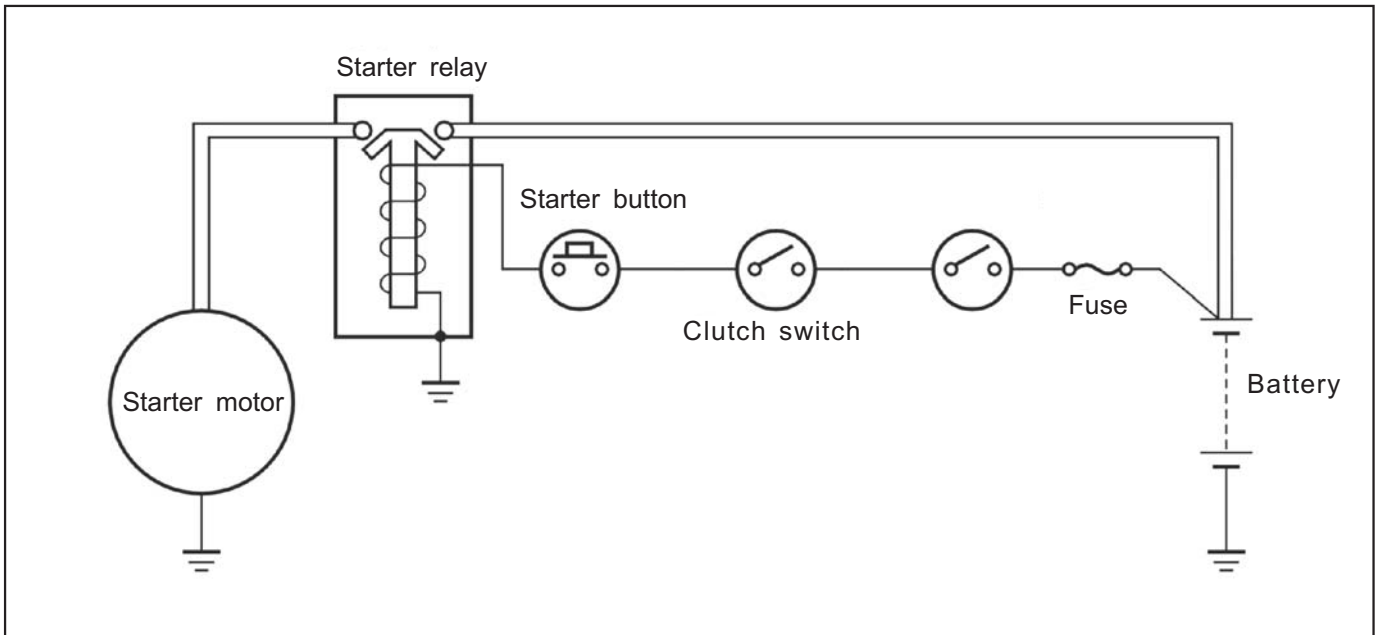

TROUBLESHOOTING

* Check: One of the front and rear brake light switches is ON position.

Ignition switch is ON position

Fuse is not blown before the diagnosis.

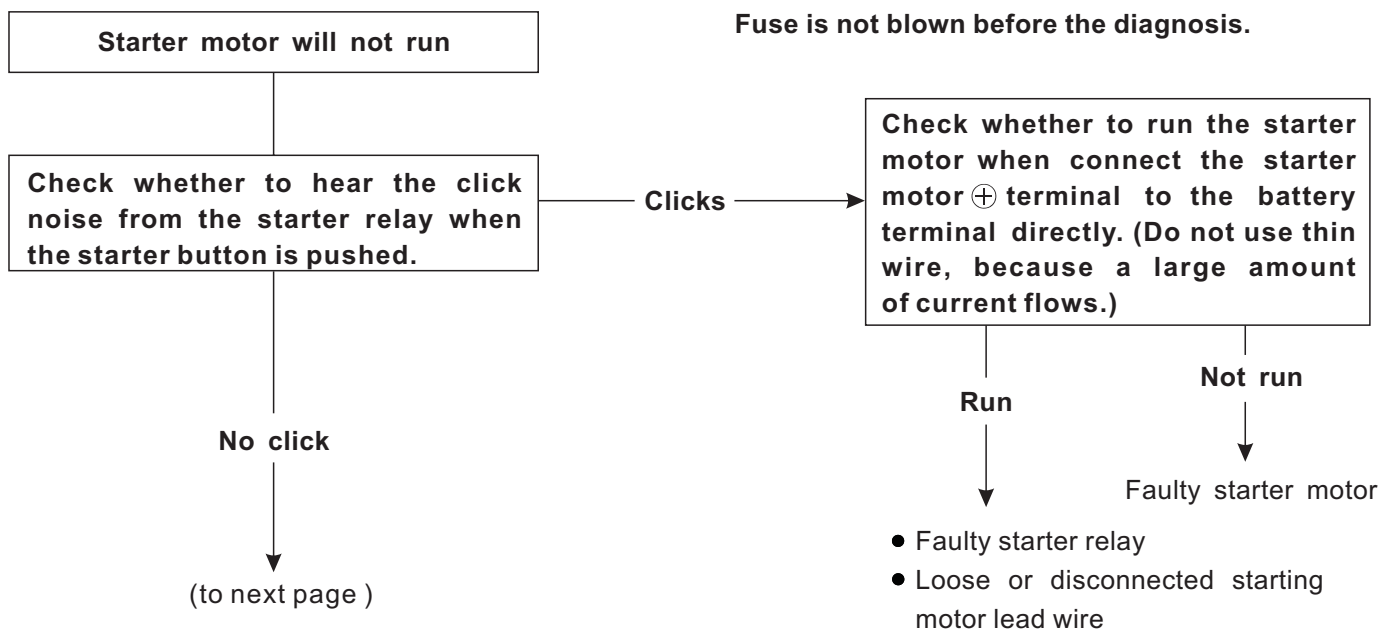

Measure the starter relay voltage at the starter relay connectors (between Y/G ⊕ and W/B ⊖) when the starter button is pushed.

Not voltage

- Faulty ignition switch
- Faulty front brake light switch
- Faulty rear brake light switch
- Faulty starter button
- Poor contact of connector
- Open circuit in wiring harness

Voltage measured

Check the starter relay (Refer to page 6-9)

Incorrect

- Faulty starting relay

Starter motor runs, but does not start engine.

- Open circuit in wiring harness
- Poor contact of connector
- Faulty CDI unit
- Faulty ignition coil
- Faulty generator
- Faulty starter clutch

STARTER MOTOR DISASSEMBLY

- Remove the starter motor. (Refer to page 3-7)
- Disassemble the starter motor as shown.

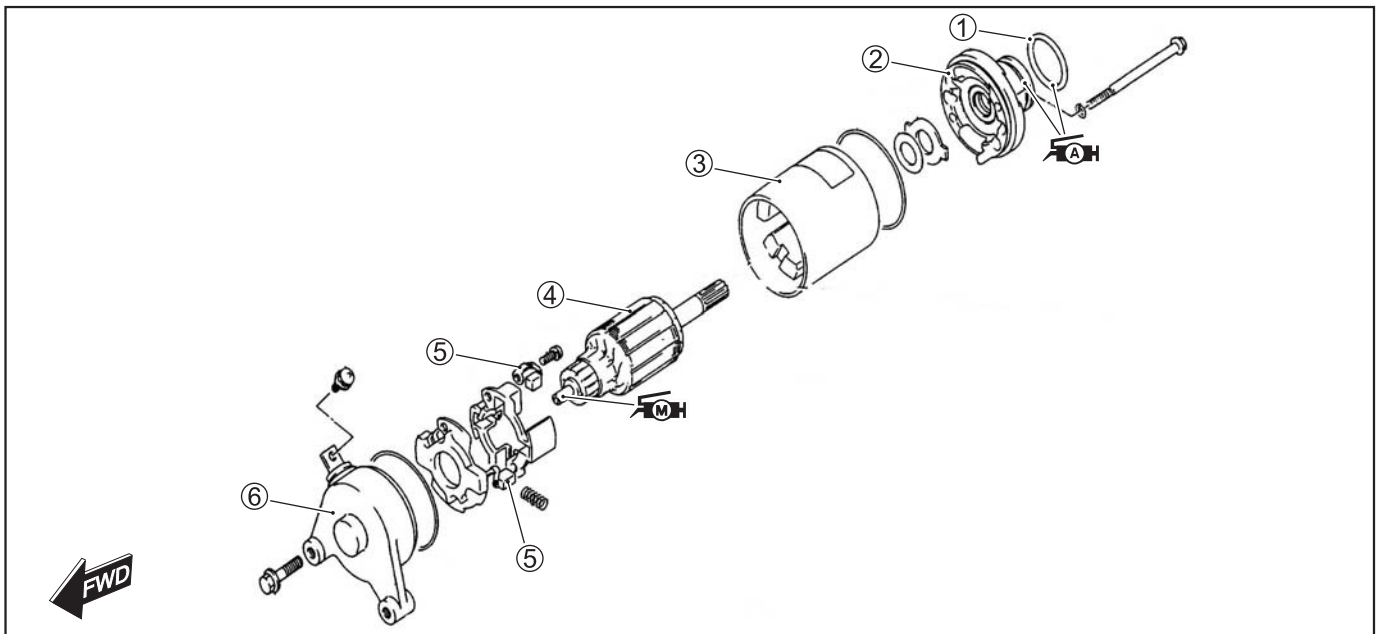

①	O-ring	④	Amature shaft
②	Housing end(outside)	⑤	Carbon brush
③	Starter motor body	⑥	Housing end(inside)

STARTER MOTOR INSPECTION

CARBON BRUSH

Inspect the carbon brushes for abnormal wear, cracks or smoothness in the brush holder.

If either carbon brush is defective, replace the brush with a new one.

Measure the length of the carbon brushes using a vernier calipers.

If the measurement is less than the service limit, replace the brush with a new one.

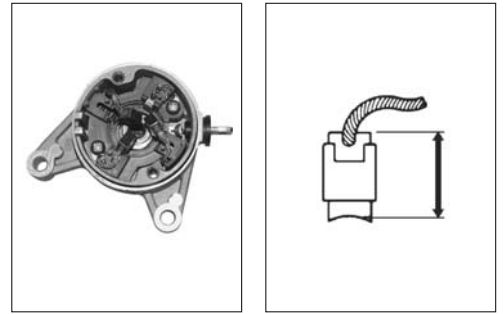

COMMUTATOR

Inspect the commutator for discoloration, abnormal wear.

If the commutator is abnormally worn, replace the armature.

If the commutator surface is discolored, polish it with #400 sandpaper and wipe it using a clean, dry cloth.

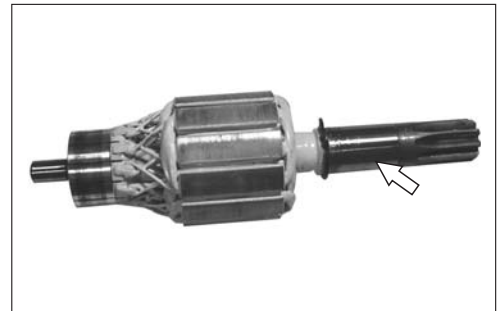

ARMATURE COIL

Inspect for continuity between each segment and between each segment and the armature shaft using the multi circuit tester.

If there is no continuity between the segments or there is continuity between the segments and shaft, replace the armature with a new one.

 **09900-25008: Multi circuit tester**

 **Tester knob indication: Continuity test**

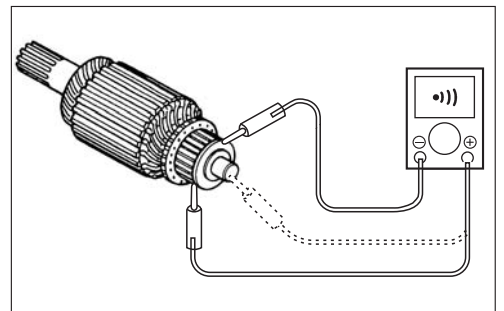

STARTER MOTOR REASSEMBLY

Fit the depression ① of the starter motor case to the groove ② of the housing end (out side).

Align the match mark ③ on the starter motor case with the match mark ④ on the housing end (inside).

.

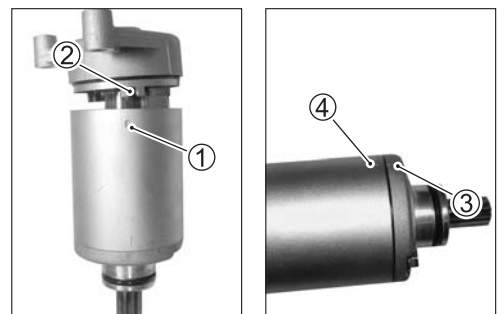

STARTER RELAY INSPECTION

- Remove the left frame cover.
- Remove the starter motor lead wire.
- Set the ignition switch to "ON" position, press the starter button and check for continuity between the positive ⊕ and negative ⊖ terminals using the pocket tester. If the starter relay clicks and continuity is found, the relay is OK.

 **09900-25008: Multi circuit tester**

 **Tester knob indication: Continuity test**



ELECTRICAL

- Measure the relay coil resistance between the terminals using the multi circuit tester. If the resistance is not within the specified value, replace the starter relay with a new one.



09900-25008: Pocker tester



Tester knob indication: Resistance (Ω)



Starter relay resistance: 3-6 Ω



IGNITION SYSTEM DESCRIPTION

In the capacitor discharged ignition system, the electrical energy generated by the magneto charges the capacitor. This energy is released in a single surge at the specified ignition timing point, and current flows through the primary side of the ignition coil. A high voltage current is induced in the secondary windings of the ignition coil resulting in strong spark between the spark plug cap.

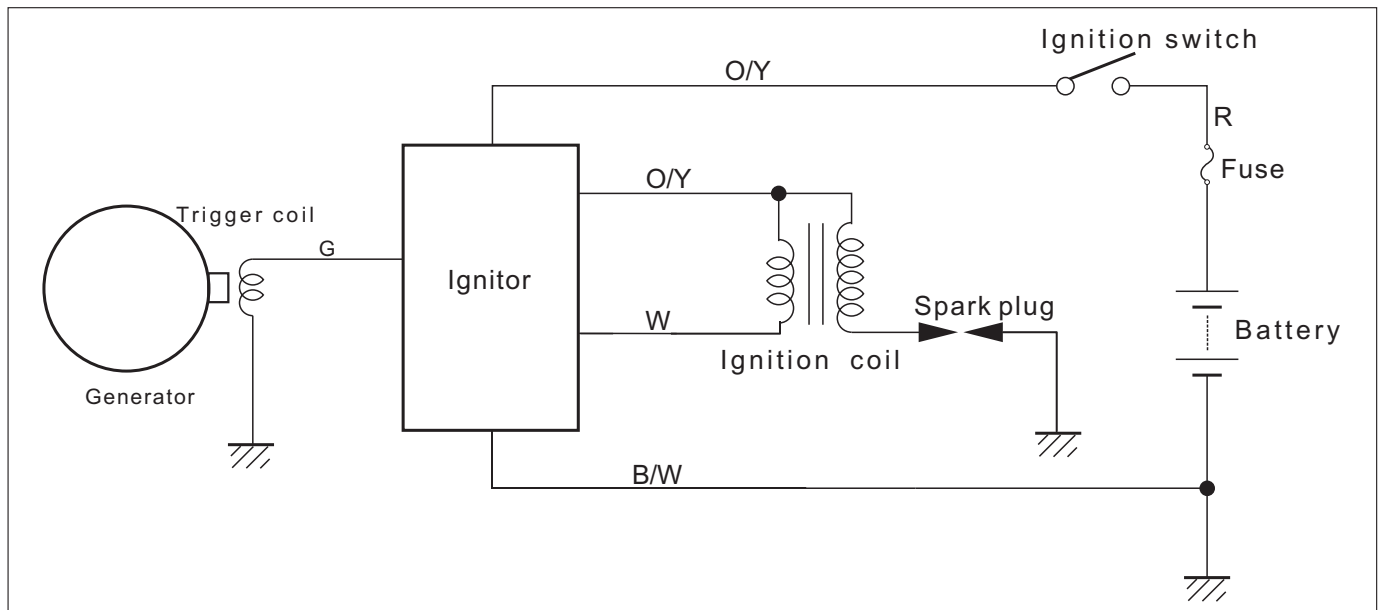

TROUBLESHOOTING

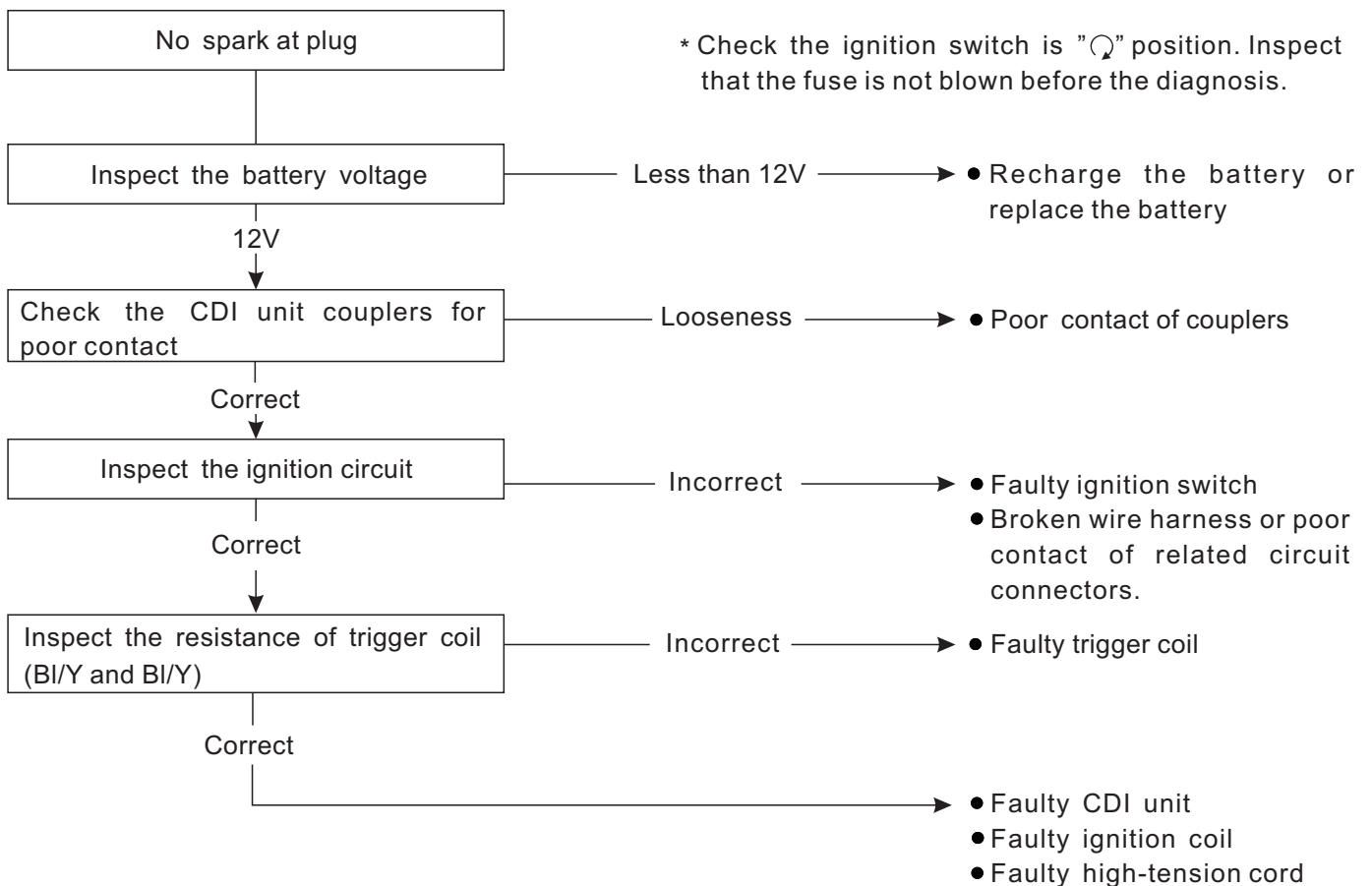

IGNITION COIL

- Remove the spark plug cap ①.

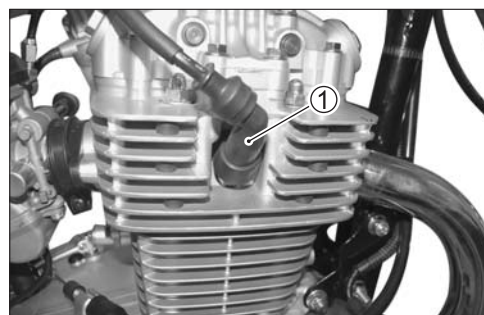

- Inspect the resistance of ignition coil with the pocket tester.

TOOL 09900-25008: Pocket tester

TESTER Tester knob indication: X1 Ω range

DATA Primary: 3. 4-4.6 Ω (tap-tap)

Secondary: 11.05-14.95 k Ω (tap- plug cap)

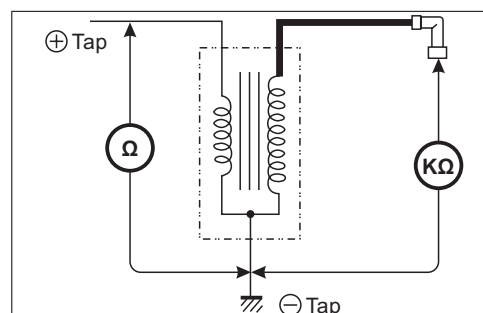

Trigger coil

- Measure resistance between lead wires using multi-circuit tester. If resistance is out of specified values, replace with new trigger coil.

TOOL 09900-25008: Pocket tester

TESTER Tester knob indication: X1 Ω range

DATA Trigger coil resistance: 110 Ω (BI-G)



Spark plug

(Refer to page 2-7)

IGNITOR UNIT

If the ignition system doesn't work properly and abnormality is not detected in the inspections above, replace the ignitor unit.

TOOL 09900-25008: Pocket tester

CHARGING SYSTEM DESCRIPTION

The circuit of the charging system is indicated in the figure, which is composed of an AC generator, regulator/rectifier unit and battery.

The AC current generated from AC generator is converted by rectifier and is turned into DC current, then is charges the battery.

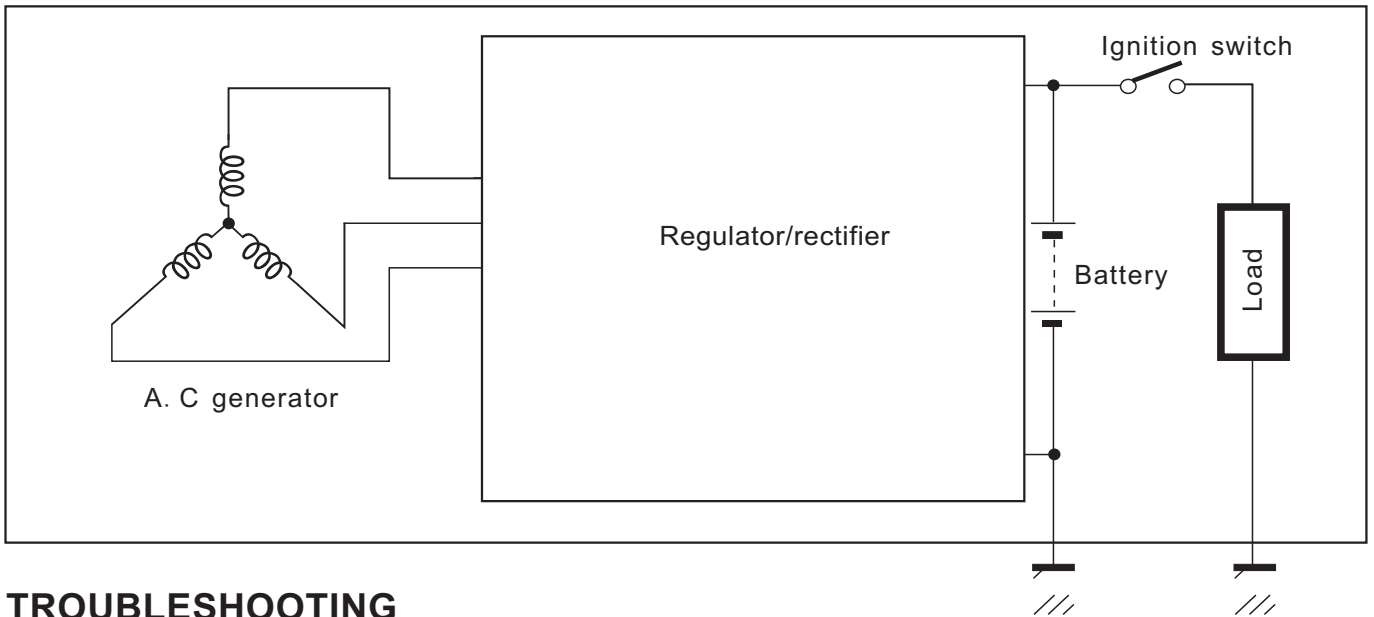

TROUBLESHOOTING

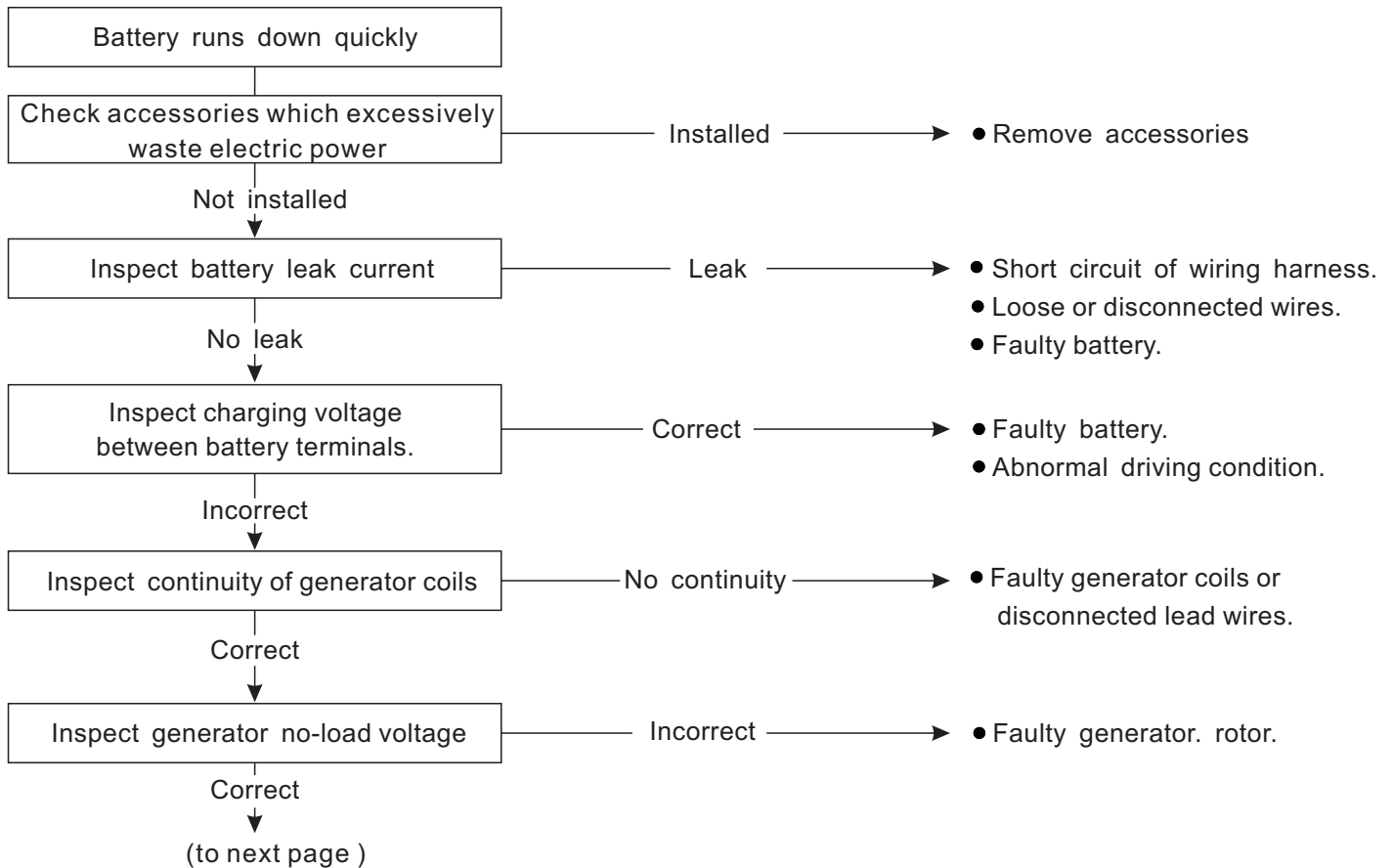

(Continue the last page)

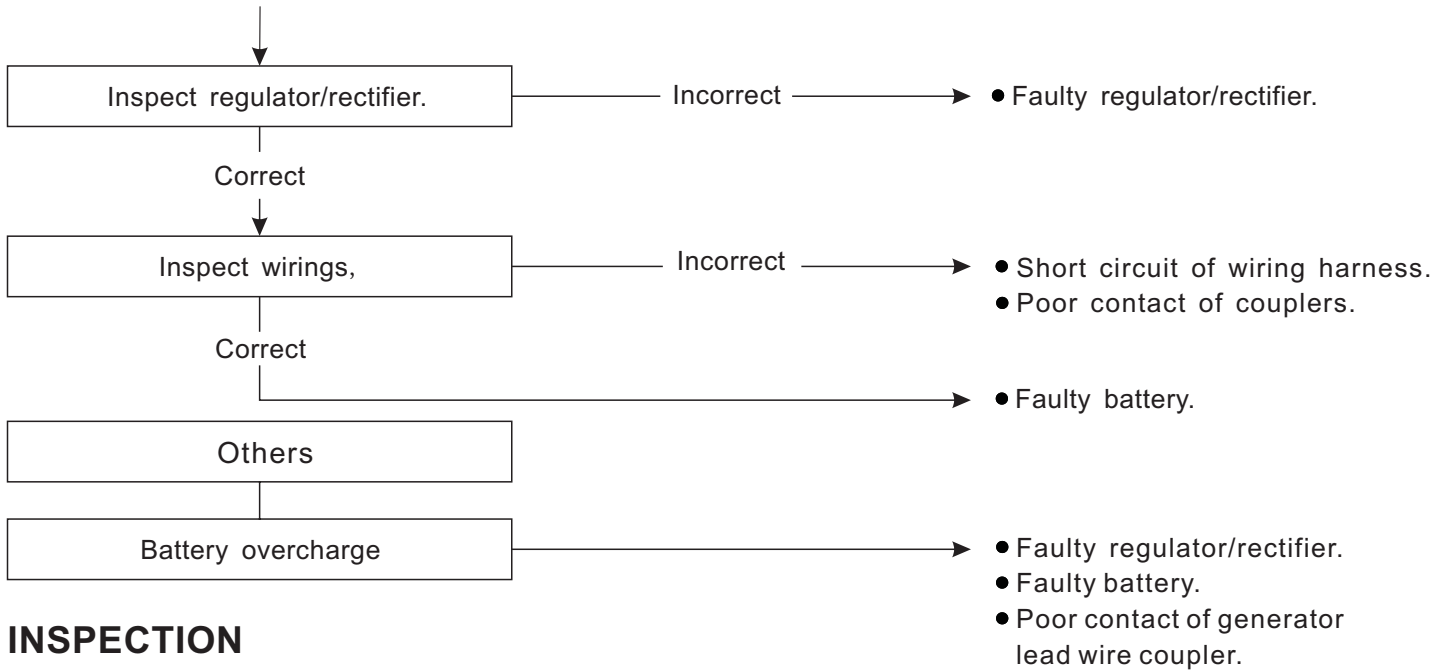

INSPECTION

BATTERY LEAK CURRENT INSPECTION

- Remove the left side cover .
- Turn the ignition switch to the OFF position.
- Disconnect the battery lead wire.
- Measure voltage between the battery - terminal and the specified ground cable terminal. If the reading exceeds the specified value, then leakage is present.

TOOL 09900-25008: Pocket tester

DATA Battery leakage: Less than 10 μ A

TESTER Tester knob indication: (-----, 200 μ A)

CAUTION

Because the leak current might be large, turn the tester to high range first when connecting an ammeter.

Do not turn the ignition switch to the ON position when measuring current.

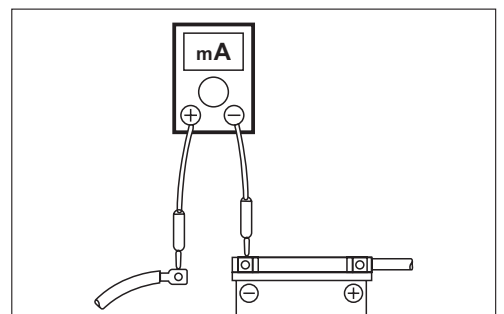

GENERATOR COIL INSPECTION

- Remove the right side cover.
- Disconnect generator coupler ①.
- Measure the resistance between the lead wires, if the resistance is incorrect, replace the generator coil.

TOOL 09900-25008: Pocket tester

TESTER Tester knob indication: Resistance

DATA Generator coil resistance: 0.9 Ω (Y-Y)

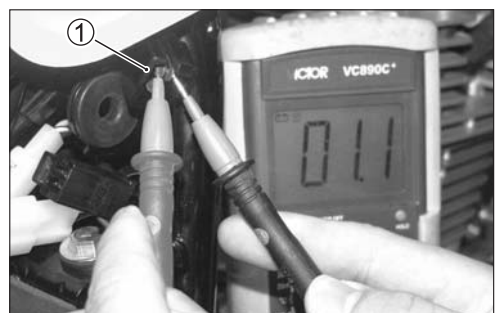

CHARGING OUTPUT INSPECTION

- Remove the left side cover.
- Start the engine, keep it running at 5 000 r/min, with lighting switch turned ON and dimmer switch turned HI position.
- Measure the DC voltage between the battery terminal and with a pocket tester. If the tester reads under the specified value, inspect the generator coil and regulator/rectifier.

⚠ CAUTION

When making this test, be sure that the battery is fully-charged condition.

TOOL 09900-25008: Pocket tester

TESTER Tester knob indication: Voltage

DATA Charging output

Standard: 14.6-15.4V at 5 000 r/min

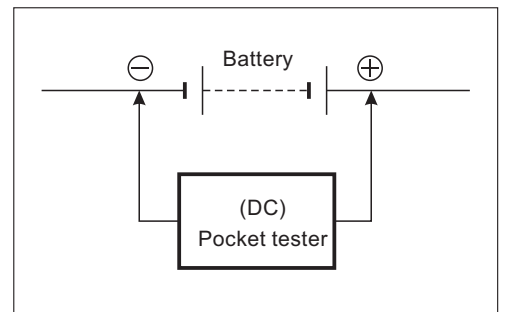

GENERATOR NO-LOAD PERFORMANCE INSPECTION

- Disconnect the generator coupler. (Refer to page 6-4)
- Start engine and keep it running at 5,000 rpm.
- Measure voltage between generator terminal and ground by using the pocket tester. If the reading is below standard values, replace with a new generator coil. (Refer to page 3-35)

⚠ CAUTION

It is not necessary to remove the engine from the chassis during the removal the generator coil.

TOOL 09900-25008: Pocket tester

TESTER Tester knob indication: Voltage

DATA Generator no-load performance:

75.5-80V/5000 r/min
(When engine is cold)

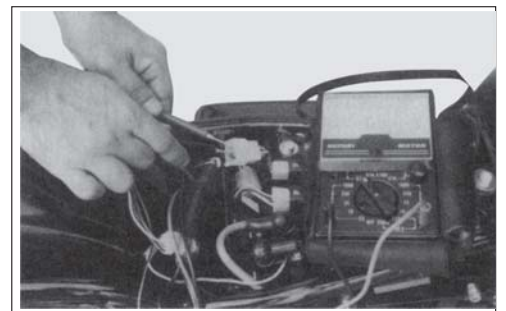

Regulator/rectifier inspection

- If the resistance checked is incorrect, replace the regulator/rectifier.

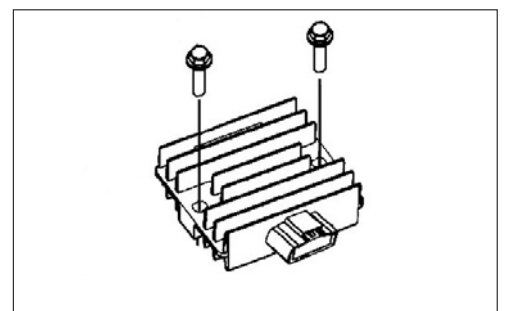

FUEL LEVEL GAUGE REMOVAL

- Remove the fuel tank. (Refer to page 3-2)
- Remove the fuel level gauge.

INSPECTION

FUEL LEVEL GAUGE

- Remove the fuel level gauge. (Refer to page 4-3)
- Check the resistance of each float position with a pocket tester.
- If the resistance measured is incorrect, replace the fuel gauge assembly with a new one.
- The relation between the position of the fuel gauge float and resistance is shown in the following table.

Float position	Resistance
Ⓐ Full	4-10Ω
Ⓑ Empty	90-100Ω

TOOL 09900-25008: Pocket tester

Tester knob indication: x 1 Ω range

⚠ CAUTION

When inspecting the gauge resistance, be sure to disconnect the battery lead wire, or a pocket tester may be damaged.

FUEL METER

- Disconnect fuel level gauge coupler. (Refer to page 4-2)
- To test the fuel meter two different checks may be used. The first, connect a jumper wire between B/W and Y/B wires coming from the main wiring harness. With the ignition switch turned ON, the fuel meter should indicate "F". The second test will check the accuracy of the meter in the full and empty positions.
- Fuel meter is normal if its pointer indicates the E(empty) position when the specified resistance is applied to the circuit and if its pointer indicates the F(full) position when the resistor is changed to 4-10 ohms. If either one or both indications are abnormal, replace the fuel meter with a new one.

Resistance	4-10 Ω	90-100 Ω
Float position	Full	Empty

⚠ CAUTION

When inspecting the gauge resistance, be sure to disconnect the battery lead wire, or a pocket tester may be damaged.

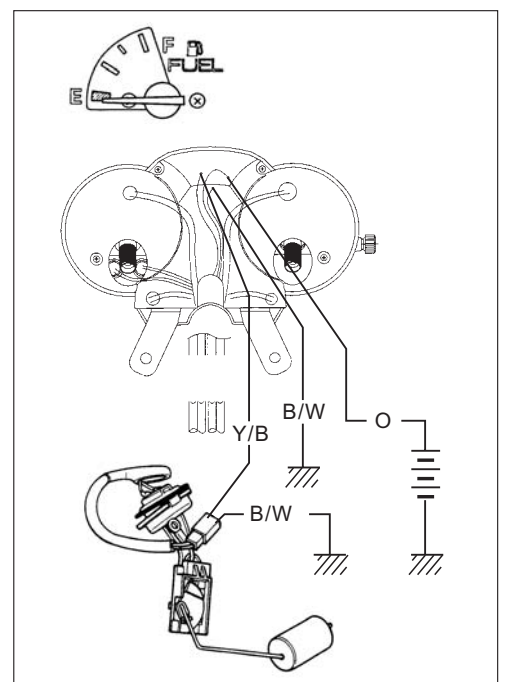
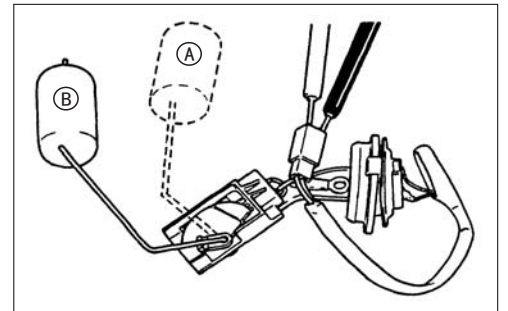
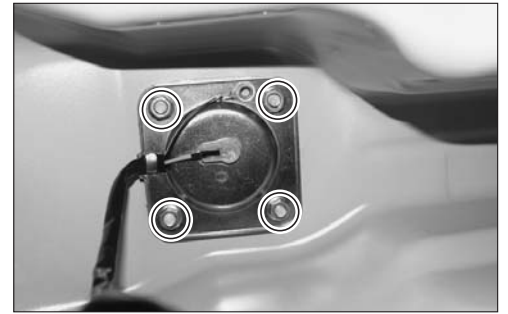

DASHBOARD

- Remove the dashboard assembly. (Refer to page 5-13)
- Disassemble the dashboard assembly as follows.

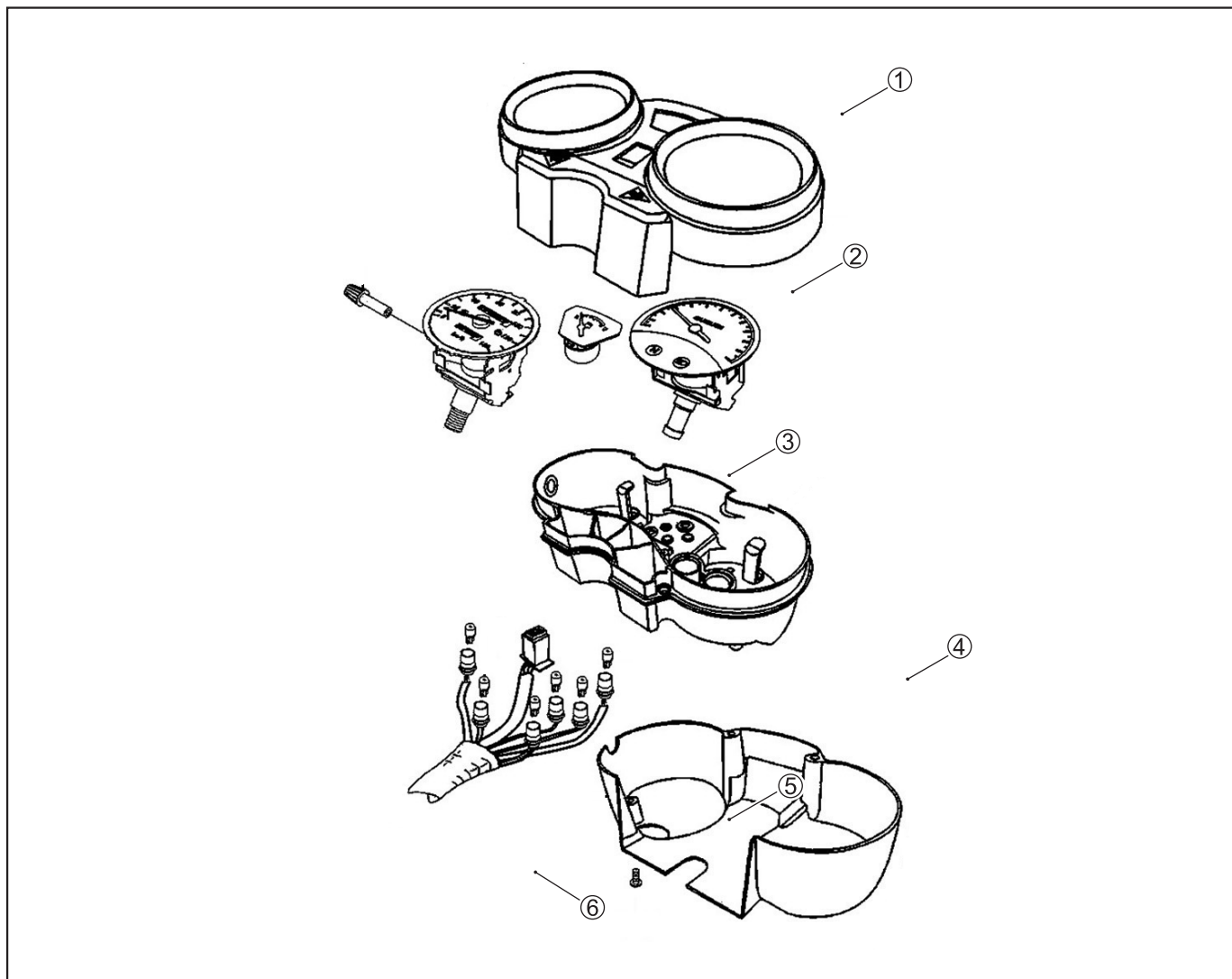

①	Upper case	④	Speedometer cable
②	Dashboard unit	⑤	Bulb
③	Lower case	⑥	Wiring harness

INSPECTION

- Using the pocket tester, check the continuity between lead wires.
- If the continuity measured is incorrect, replace the respective parts.

TOOL 09900-25008: Multi circuit tester

Tester knob indication: Continuity

CAUTION

When making this test, it is not necessary to remove the dashboard.

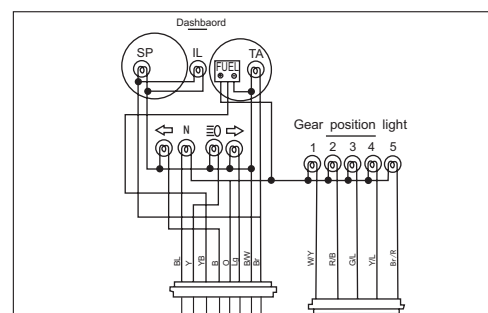

LIGHTS

HEADLIGHT

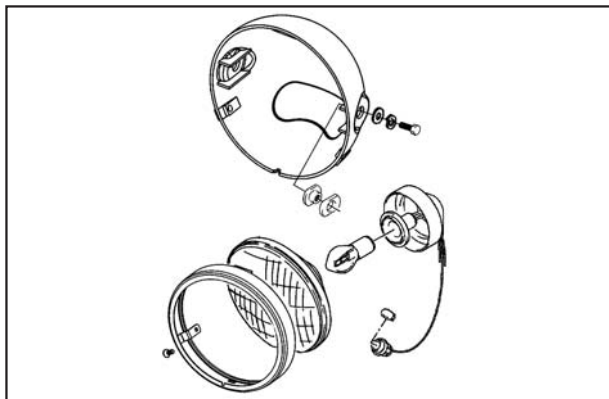

TURN SIGNAL LIGHT

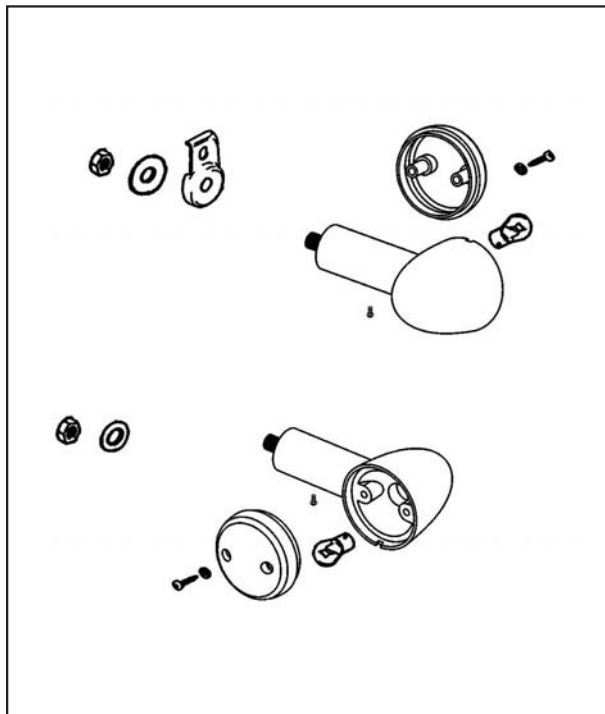

TAIL LIGHT/BRAKE LIGHT

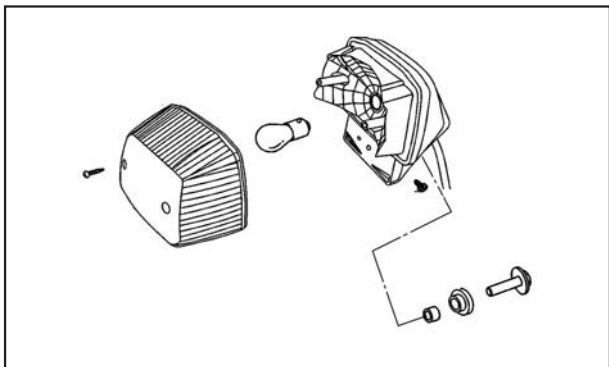

SWITCHES

Inspect each switch for continuity with the pocket tester. If any abnormality is found, replace the respective switch assemblies with new ones.

 **09900-25008: Pocket tester**

 **Test scale: Continuity**



IGNITION SWITCH

	O	R	O/Y
OFF			
ON	○	○	○
			

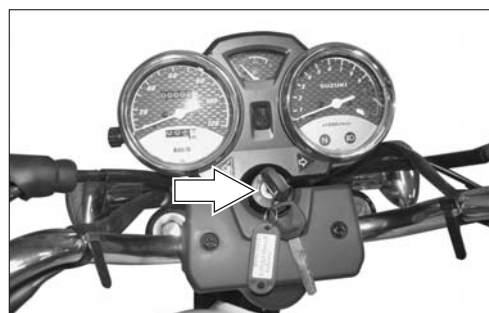

ELECTRICAL

ENGINE STOP SWITCH ①

	O/B	O/W
⊗		
⊙	○	○

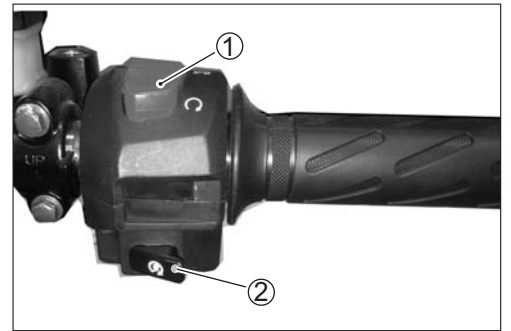

STARTER SWITCH ②

	O/W	Y/G
OFF		
⚡	○	○

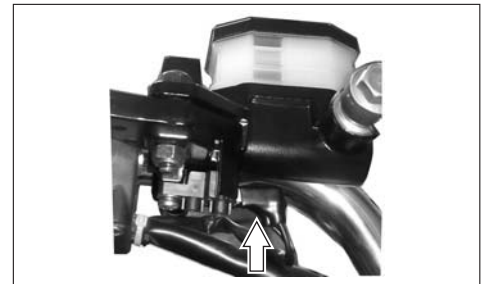

FRONT BRAKE LIGHT SWITCH

	B	B
OFF		
ON	○	○

DIMMER SWITCH ③

	Y/W	Y	W
☰	○		○
☷	○	○	

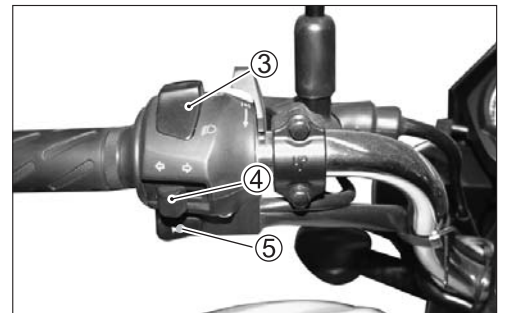

TURN SIGNAL LIGHT SWITCH ④

	B	Sb	Lg
➡		○	○
•			
➡	○	○	

HORN SWITCH ⑤

	B/L	B/W
OFF		
📢	○	○

ELECTRICAL

PASS SWITCH ⑦

	Y	O
FREE		
PUSH	○	○

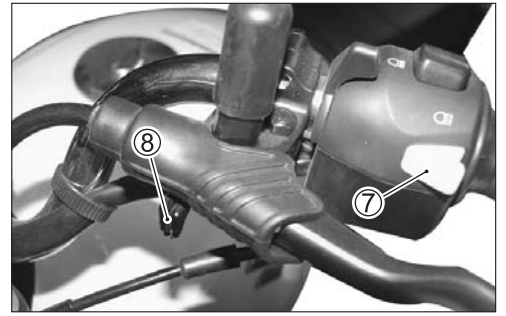

CLUTCH SWITCH ⑧

	B/Y	B/W
●		
PUSH	○	○

REAR BREAK LIGHT SWITCH ⑨

	O	W/B
OFF		
ON	○	○

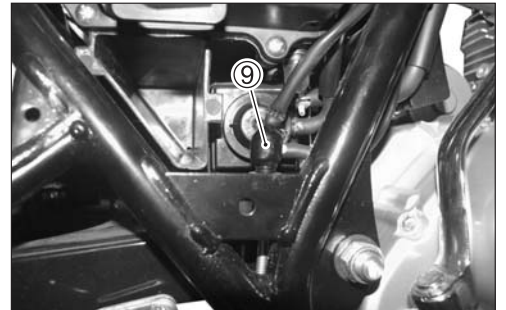

GEAR POSITION INDICATION LIGHT SWITCH ⑩

	Ground	L	W/Y	R/B	G/L	Y/L	Br/R
Neutral	○	○					
Low	○		○				
2nd	○			○			
3rd	○				○		
4th	○					○	
Top	○						○

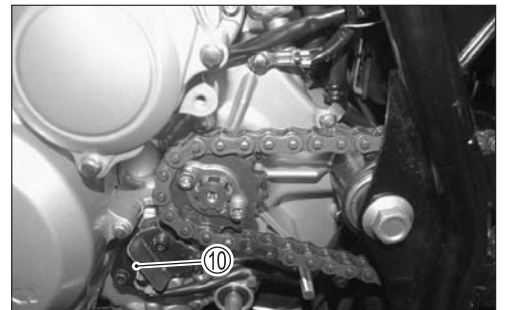

BATTERY SPECIFICATIONS

TYPE	12N7-4A
Capacity	7 Ah
Standard electrolyte S.G.	1.28 ± 0.01 20°C

- In fitting the battery to the motorcycle, connect the breather tube to the battery vent.

INITIAL CHARGING

Filling electrolyte

Remove the short sealed tube before filling electrolyte. Fill battery with electrolyte (dilute sulfuric acid solution with acid concentration of 35.0% by weight, having a specific gravity of 1.28 at 20°C/86°F) up to indicated UPPER LEVEL. Filling electrolyte should be always cooled below 20°C/86°F before filling into battery. Leave battery standing for half an hour after filling. Add additional electrolyte if necessary.

Charge battery with current as described in the tables shown below.

Standard Charging current	0.7 A
---------------------------	-------

CHARGING TIME

The charging time for a new battery is determined by the number of months that have elapsed since the date of manufacture.

Near the end of charging period, adjust the specific gravity of electrolyte to value specified. After charging, adjust the electrolyte level to the UPPER LEVEL with DISTILLED WATER.

Months after manufacturing	6-12	Over 12
Necessary charging hours	5	8

Servicing

- Visually inspect the surface of the battery container. If any signs of cracking or electrolyte leakage from the sides of the battery have occurred, replace the battery with a new one.
- If the battery terminals are found to be coated with rust or an acidic white powdery substance, then this can be cleaned away with sandpaper.

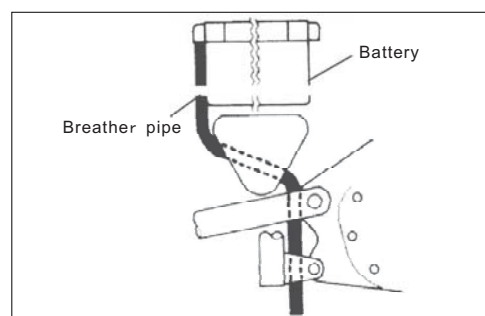

ELECTRICAL

- Check the electrolyte level and add distilled water, as necessary, to raise the electrolyte to each cell's upper level.
- Check the battery for proper charge by taking an electrolyte S.G. reading. If the reading is 1.22 or less, as corrected to 20°C, it means that the battery is still in a run-down condition and needs recharging.



⚠ CAUTION

Disconnect the ⊖ lead first.

BASED ON S.G. READING RECHARGING OPERATION

- To read the S. G. on the hydrometer, bring the electrolyte in the hydrometer to eye level and read the graduations on the float scale bordering on the meniscus (curved-up portion of electrolyte) as shown in figure.
- Check the reading (as corrected to 20°C) with chart to determine the recharging time in hours by constant-current charging at a charging rate of 0.7A.
- Be careful not to permit the electrolyte temperature to exceed 45 °C, at any time during the recharging operation. Interrupt the operation, as necessary, to let the electrolyte cool down. Recharge the battery to the specification.

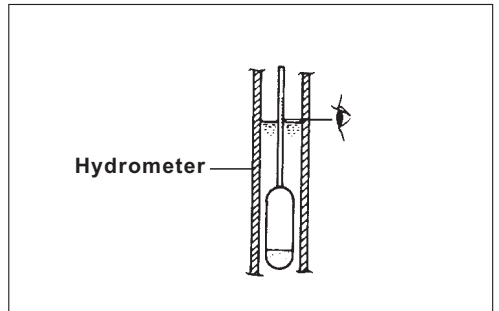
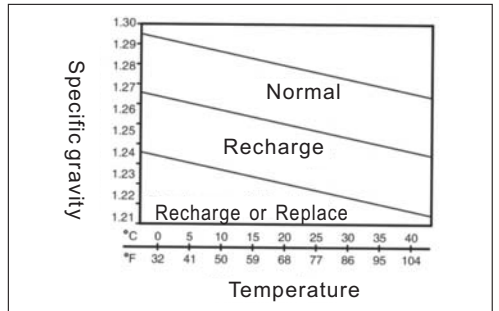

TOOL 09900-28403: Hydrometer

Electrolyte specific gravity	1.28 ± 0.01 20 °C
-------------------------------------	--------------------------

⚠ CAUTION

Before charging a battery, remove the seal cap from each cell.
Keep fire and sparks away from a battery being charged.
When removing a battery from the motorcycle, be sure to remove the ⊖ terminal first.

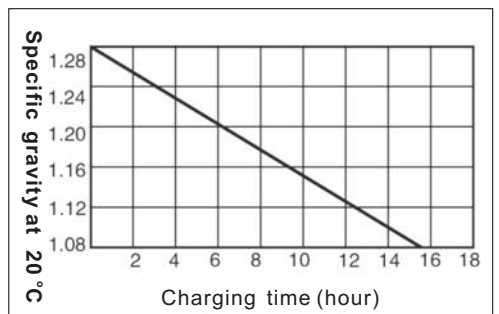

⚠ CAUTION

Constant-voltage charging, otherwise called “quick” charging, is not recommendable for it could shorten the life of the battery.

SERVICING INFORMATION

CONTENTS

TROUBLESHOOTING	7-1
SPECIAL TOOLS	7-7
TIGHTENING TORQUE	7-9
SERVICE DATA	7-11
WIRE AND CABLE ROUTING	7-16
WIRING DIAGRAM	7-18

TROUBLESHOOTING

ENGINE

Complaint	Symptom and possible causes	Remedy
<p>Engine will not start or is hard to start.</p>	<p>Compression too low</p> <ol style="list-style-type: none"> 1. Valve clearance out of limit. 2. Worn valve guides or poor seating of valves. 3. Valves mistiming. 4. Piston rings excessively worn. 5. Worn-down cylinder bore. 6. Poor seating of spark plug. 7. Starting motor cranks but too slowly. <p>Plug not sparking</p> <ol style="list-style-type: none"> 1. Fouled spark plug. 2. Wet spark plug. 3. Defective trigger coil. 4. Defective ignitor unit. 5. Defective ignition coil. <p>No fuel reaching the carburetor</p> <ol style="list-style-type: none"> 1. Clogged hole in the fuel tank cap. 2. Clogged or defective fuel cock. 3. Defective carburetor float needle valve. 4. Clogged fuel pipe. 5. Clogged fuel filter. 	<p>Adjust. Repair or replace. Adjust. Replace. Replace or rebore. Retighten. Consult "electrical complaints"</p> <p>Clean or replace. Clean and dry. Replace. Replace. Replace.</p> <p>Clean. Clean or replace. Replace. Clean or replace. Clean or replace.</p>
<p>Engine stalls easily</p>	<ol style="list-style-type: none"> 1. Fouled spark plug. 2. Defective trigger coil. 3. Defective ignitor unit. 4. Clogged fuel pipe. 5. Clogged jets in carburetor. 6. Valve clearance out of limit. 7. Clogged fuel filter. 	<p>Clean. Replace. Replace. Clean. Clean. Adjust. Clean or replace.</p>
<p>Noisy engine</p>	<p>Excessive valve chatter</p> <ol style="list-style-type: none"> 1. Valve clearance too large. 2. Weakened or broken valve springs. 3. Worn down rocker arm or rocker arm shaft. <p>Noise appears to come from piston</p> <ol style="list-style-type: none"> 1. Piston or cylinder worn down. 2. Combustion chamber fouled with carbon. 3. Piston pin or piston pin bore worn. 4. Piston rings or ring groove worn. <p>Noise seems to come from clutch</p> <ol style="list-style-type: none"> 1. Worn splines of countershaft or hub. 2. Worn teeth of clutch plates. 3. Distorted clutch plates, driven and drive. 4. Clutch damper weakened. <p>Noise seems to come from crankshaft</p> <ol style="list-style-type: none"> 1. Worn or burnt bearings. 2. Big-end bearings worn and burnt. 3. Thrust clearance too large. <p>Noise seems to come from transmission</p> <ol style="list-style-type: none"> 1. Gears worn or rubbing. 2. Badly worn splines. 3. Primary gears worn or rubbing. 4. Badly worn bearings. 	<p>Adjust. Replace. Replace.</p> <p>Replace. Clean. Replace. Replace.</p> <p>Replace. Replace. Replace. Replace.</p> <p>Replace. Replace. Replace.</p> <p>Replace. Replace. Replace.</p>
<p>Slipping clutch.</p>	<ol style="list-style-type: none"> 1. Clutch control out of limit or loss of play. 2. Weakened clutch springs. 3. Worn or distorted pressure plate. 4. Distorted clutch plates, driven and drive. 	<p>Adjust. Replace. Replace. Replace.</p>

SERVICING INFORMATION

Complaint	Symptom and possible causes	Remedy
Dragging clutch.	<ol style="list-style-type: none"> 1. Clutch control out of adjustment or too much play. 2. Some clutch springs weakened. 3. Distorted pressure plate or clutch plates. 	<p>Adjust. Replace. Replace.</p>
Transmission will not shift.	<ol style="list-style-type: none"> 1. Broken gearshift cam. 2. Distorted gearshift forks. 3. Worn gearshift pawl. 	<p>Replace. Replace. Replace.</p>
Transmission will not shift back.	<ol style="list-style-type: none"> 1. Broken return spring on shift shaft. 2. Shift shafts are rubbing or sticky. 3. Distorted or worn gearshift forks. 	<p>Replace. Repair. Replace.</p>
Transmission jumps out of gear.	<ol style="list-style-type: none"> 1. Worn shifting gears on drive-shaft or counter-shaft. 2. Distorted or worn gearshift forks. 3. Weakened stopper pawl spring on gearshift cam. 4. Worn gearshift pawl. 	<p>Replace. Replace. Replace. Replace.</p>
Engine idles poorly.	<ol style="list-style-type: none"> 1. Valve clearance out of limit. 2. Poor seating of valves. 3. Defective valve guides. 4. Worn rocker arm or arm shaft. 5. Defective trigger coil. 6. Defective ignitor unit. 7. Spark plug gap too wide. 8. Defective ignition coil resulting in weak sparking. 9. Clogged jets. 	<p>Adjust. Replace. Replace. Replace. Replace. Replace. Adjust or replace. Replace. Clean.</p>
Engine runs poorly in high speed range.	<ol style="list-style-type: none"> 1. Valve springs weakened. 2. Valve timing out of limit. 3. Worn cams or rocker arms. 4. Spark plug gap too narrow. 5. Defective ignition coil. 6. Clogged air cleaner element. 7. Clogged fuel hose, resulting in inadequate fuel supply to carburetor. 8. Defective trigger coil or ignitor unit. 	<p>Replace. Adjust. Replace. Repair. Replace. Clean. Clean and prime. Replace.</p>
Dirty or heavy exhaust smoke.	<ol style="list-style-type: none"> 1. Too much engine oil in the engine. 2. Worn piston rings or cylinder. 3. Worn valve guides. 4. Cylinder wall scored or scuffed. 5. Worn valves stems. 6. Defective stem seals. 7. Worn oil rings. 	<p>Check with inspection window. Replace. Replace. Replace. Replace. Replace. Replace.</p>
Engine lacks power.	<ol style="list-style-type: none"> 1. Loss of valve clearance. 2. Weakened valve springs. 3. Valve timing out of limit. 4. Worn piston ring or cylinder. 5. Poor seating of valves. 6. Fouled spark plug. 7. Worn rocker arms or its shafts. 8. Spark plug gap incorrect. 9. Clogged jets in carburetor. 10. Clogged air cleaner element. 11. Too much engine oil. 12. Suck air intake pipe. 	<p>Adjust. Replace. Adjust. Replace. Repair. Clean or replace. Replace. Adjust or replace. Clean. Clean. Drain out excess oil. Retighten or replace.</p>
Engine overheats.	<ol style="list-style-type: none"> 1. Heavy carbon deposit on piston crown. 2. Not enough oil in the engine. 3. Defective oil pump or clogged oil circuit. 4. Air leak from intake pipe. 5. Use of incorrect engine oil. 	<p>Clean. Pour oil. Repair or clean. Retighten or replace. Change.</p>

SERVICE INFORMATION

CARBURETOR

Complaint	Symptom and possible causes	Remedy
Trouble with starting.	<ol style="list-style-type: none"> 1. Starting jet is clogged. 2. Starting pipe is clogged. 3. Air leakage from a joint between choke and carburetor. 4. Air leakage at carburetor joint or vacuum tube joint. 5. Starting plunger is not operated properly. 	<p>Clean. Clean. Check and retighten. Check and retighten. Check and adjust.</p>
Idle or low speed trouble.	<ol style="list-style-type: none"> 1. Idle jet, idle air jet are clogged or loose. 2. Air leakage at carburetor joint, vacuum tube joint or choke. 3. Idle outlet or by-pass is clogged. 4. Starting plunger is not fully closed. 	<p>Check and clean. Check and retighten.</p> <p>Check and clean. Check and adjust.</p>
Medium or high-speed trouble.	<ol style="list-style-type: none"> 1. Main jet or main air jet is clogged. 2. Bubbling pipe is clogged. 3. Throttle valve is not operated properly. 4. Air filter is clogged. 	<p>Check and clean. Check and clean. Check and adjust. Check and clean.</p>
Overflow and fuel level fluctuations.	<ol style="list-style-type: none"> 1. Needle valve is worn or damaged. 2. Needle valve spring is broken. 3. Float is not working properly. 4. Foreign matter has adhered to needle valve. 	<p>Replace. Replace. Check and adjust. Clean.</p>

BRAKES

Complaint	Symptom and possible causes	Remedy
Poor braking.	<ol style="list-style-type: none"> 1. Not enough brake fluid in the reservoir. 2. Air trapped in brae fluid circuit. 3. Pads worn down. 4. Linings worn down. 5. Brake disc worn down. 6. Wheel hub worn down. 7. Oil adhesion on engaging surface of pads or linings. 8. Too much play on brake lever. 	<p>Check and refill to level mark. Bleed air out. Replace. Replace. Replace. Replace. Clean. Adjust.</p>
Brake squeaking.	<ol style="list-style-type: none"> 1. Carbon adhesion on pad surface. 2. Tilted pad. 3. Damaged wheel bearing. 4. Loose front-wheel axle or rear-wheel axle. 5. Pads or linings worn down. 6. Foreign material in brake fluid. 7. Clogged return port of master cylinder 	<p>Repair surface with sandpaper. Modify pad fitting. Replace. Tighten to specified torque. Replace. Replace brake fluid. Disassemble and clean master cylinder.</p>
Excessive brake lever free stroke.	<ol style="list-style-type: none"> 1. Air in hydraulic system. 2. Brake lever cam worn down. 3. Insufficient brake fluid. 4. Improper quality of brake fluid. 5. Brake linings or wheel hub worn down. 	<p>Bleed air out. Replace brake lever. Replenish . Replace with correct fluid. Replace.</p>
Leakage of brake fluid.	<ol style="list-style-type: none"> 1. Insufficient tightening of connection joints. 2. Cracked hose. 3. Worn piston and/or seal ring. 	<p>Tighten to specified torque. Replace. Replace piston and/or cup.</p>

SERVICE INFORMATION

CHASSIS

Complaint	Symptom and possible causes	Remedy
Steering feels too heavy or stiff.	<ol style="list-style-type: none"> 1. Steering stem nut over-tightened. 2. Worn bearing or race in steering stem. 3. Distorted steering stem. 4. Not enough pressure in tires. 	Adjust. Replace. Replace. Adjust.
Steering oscillation.	<ol style="list-style-type: none"> 1. Loss of balance between right and left front absorbers. 2. Distorted front absorbers. 3. Distorted front axle or crooked tire. 	Replace. Repair or replace. Replace.
Wobby front wheel.	<ol style="list-style-type: none"> 1. Distorted wheel rim. 2. Worn-down front wheel bearings. 3. Defective or incorrect tire. 4. Loose nut on axle. 	Replace. Replace. Replace. Retighten.
Front absorbers too soft.	<ol style="list-style-type: none"> 1. Weakened springs. 2. Not enough absorber oil. 	Replace. Refill.
Front absorbers too stiff	<ol style="list-style-type: none"> 1. Absorber oil too viscous. 2. Too much absorber oil. 	Replace. Remove excess oil.
Noisy front absorbers.	<ol style="list-style-type: none"> 1. Not enough absorbers oil. 2. Loose nuts on absorbers . 	Refill. Retighten.
Wobbly rear wheel.	<ol style="list-style-type: none"> 1. Distorted wheel rim. 2. Worn-down rear wheel bearings. 3. Defective or incorrect tire. 4. Loose nut on axle. 5. Worn swing arm bushings. 6. Loosen nuts on the rear absorbers. 	Remedy Replace. Replace. Retighten. Replace. Retighten.
Rear absorbers too soft.	<ol style="list-style-type: none"> 1. Weakened springs. 2. Rear absorbers adjuster improperly set. 	Replace. Adjust.
Rear absorbers too stiff.	<ol style="list-style-type: none"> 1. Rear suspension adjuster improperly set. 2. Worn swing arm bushings. 	Adjust. Replace.
Noisy rear absorbers.	<ol style="list-style-type: none"> 1. Loose nuts on the rear absorbers. 2. Worn swing arm bushings. 	Retighten. Replace.

ELECTRICAL











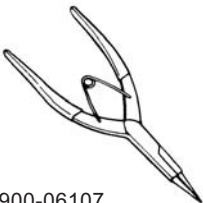

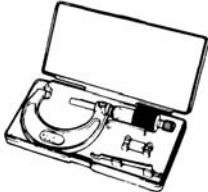



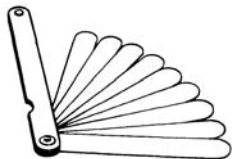
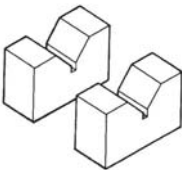
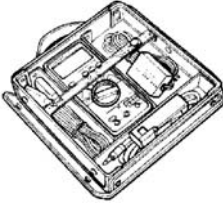
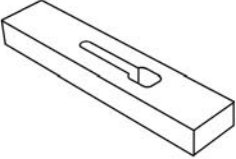
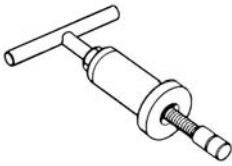
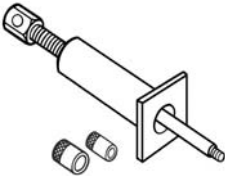

Complaint	Symptom and possible causes	Remedy
No spark or poor spark.	<ol style="list-style-type: none"> 1. Defective ignition coil. 2. Defective spark plug. 3. Defective trigger coil or ignitor unit. 	Replace. Replace. Replace.
Spark plug soon become fouled with carbon.	<ol style="list-style-type: none"> 1. Mixture too rich. 2. Too high idle speed. 3. Incorrect fuel. 4. Dirty element in air cleaner. 5. Spark plug too cold. 	Adjust carburetor. Adjust carburetor. Change. Clean. Replace by hot type plug.
Spark plug become fouled too soon.	<ol style="list-style-type: none"> 1. Worn piston rings. 2. Pistons or cylinder worn. 3. Excessive clearance of valve stems in valve guides. 4. Worn stem oil seals. 	Replace. Replace. Replace. Replace.
Spark plug electrodes overheat or burn.	<ol style="list-style-type: none"> 1. Spark plug too hot. 2. The engine overheats. 3. Defective trigger coil or ignitor unit. 4. Spark plug loose. 5. Mixture too poor. 	Replace by cold type plug. Adjust. Replace. Tighten. Adjust carburetor.
Generator does not charge.	<ol style="list-style-type: none"> 1. Opened or shorted in lead wires, or loose lead connections. 2. Shorted, grounded or opened generator coils. 3. Shorted or destroyed regulator/rectifier. 	Repair or replace or retighten. Replace. Replace.
Generator charge, but charging rate is below the specification.	<ol style="list-style-type: none"> 1. Lead wires tend to get shorted or opened circuit or loosely connected at terminals. 2. Grounded or opened circuit generator stator. 3. Defective regulator/rectifier. 4. Not enough electrolyte in the battery. 5. Defective cell plates in the battery. 	Repair or tighten. Replace. Replace. Pour distilled water between the level lines. Replace the battery.
Generator overcharges.	<ol style="list-style-type: none"> 1. Internal shorted circuit in the battery. 2. Resistor element in the regulator/rectifier damaged or defective. 3. Regulator/rectifier poorly grounded. 	Replace the battery. Replace. Clean and tighten ground connection.
Unstable charging.	<ol style="list-style-type: none"> 1. Lead wire insulation frayed due to vibration, resulting in intermittent shorted circle. 2. Generator internally shorted circle. 3. Defective regulator/rectifier. 	Repair or replace. Replace. Replace.
Starting button is not effective.	<ol style="list-style-type: none"> 1. Battery run down. 2. Defective switch contacts. 3. Brushes not seated properly on commutator in starting motor. 4. Defective starting relay. 	Recharge or replace. Replace. Repair or replace. Replace.

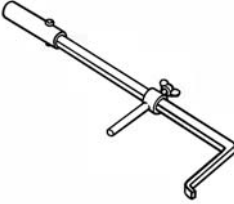
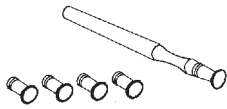
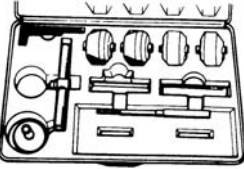
SERVICE INFORMATION

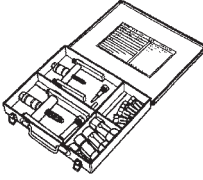

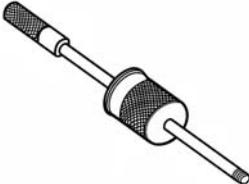

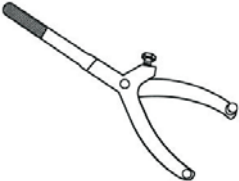
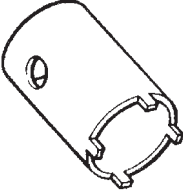

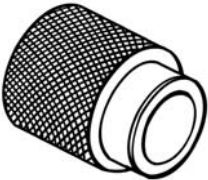

BATTERY

Complaint	Symptom and possible causes	Remedy
<p>“Sulfation”, acidic white powdery substance or spots on surface of cell plates.</p>	<ol style="list-style-type: none"> 1. Not enough electrolyte. 2. Battery case is cracked. 3. Charging rate is too low or too high. 4. Battery has been left in a run-down condition for a long time. 5. Contaminated electrolyte (Foreign matter has enters the battery and become mixed with the electrolyte.) 	<p>Pour distilled water, if the battery has not been damaged and "sulfation" has not advanced too far, and recharge. Replace. Replace. Replace.</p> <p>If "sulfation" has not advanced too far, try to restore the battery by replacing the electrolyte, recharging it fully and then adjust the electrolyte S.G.</p>
<p>Battery runs down quickly.</p>	<ol style="list-style-type: none"> 1. The charging method is not correct. 2. Cell plates have lost much of their active material as result of over-charging. 3. A shorted circuit condition exists within the battery due to excessive accumulation of sediments caused by the high electrolyte S.G. 4. Electrolyte S.G. is too low. 5. Contaminated electrolyte. 6. Battery is too old. 	<p>Check the generator, regulator/rectifier and circuit connections, and make necessary adjustments to obtain specified charging operation. Replace the battery, and correct the charging system. Replace the battery.</p> <p>Recharge the battery fully and adjust electrolyte S.G. Replace the electrolyte, recharge the battery and adjust the S.G. Replace the battery.</p>
<p>Reversed battery polarity.</p>	<p>The battery has been connected the wrong way round in the system, so that it is being charged in the reverse direction.</p>	<p>Replace the battery and be sure to connect the battery properly.</p>
<p>Battery discharges too rapidly.</p>	<ol style="list-style-type: none"> 1. Dirty container tap and sides. 2. Impurities in the electrolyte or electrolyte S.G. is too high. 	<p>Clean. Change the electrolyte by consulting the battery manufacturer's directions.</p>

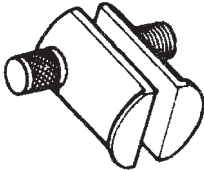
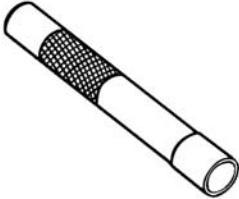
SPECIAL TOOLS

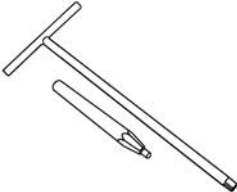
 <p>09900-06107 Snap ring pliers (open type)</p>	 <p>09900-20103 Vernier calipers (1/50mm, 300mm)</p>	 <p>09900-20202 Micrometer (1/100mm, 25~50mm)</p>	 <p>09900-20203 Micrometer (1/100mm, 50~75mm)</p>	 <p>09900-20205 Micrometer (1/100mm, 0~25mm)</p>
 <p>09900-20508 Cylinder bore gauge kit (1/100mm, 40~80mm)</p>	 <p>09900-20605 Dial calipers (1/100mm, 10~34mm)</p>	 <p>09900-20606 Dial meter (1/100mm, 10mm)</p>	 <p>09900-20701 Magnetic bracket</p>	 <p>09900-20803 Thickness gauge</p>
 <p>09900-21304 V-block (set) (100mm)</p>	 <p>09900-22302 Plastigage (0.051-0.152mm)</p>	 <p>09900-25008 Pocket tester</p>	 <p>09910-20116 Conrod holder</p>	 <p>09910-32812 Crankshaft installer</p>
 <p>09910-34510 Piston pin puller</p>	 <p>09910-60611 Universal clamp wrench</p>	 <p>09913-50121 Oil seal remover</p>	 <p>09913-70210 Bearing installer set (Φ10-75)</p>	 <p>09916-10911 Valve seat lapper set</p>
 <p>09915-21110 Valve seat reamer set</p>	 <p>09920-13120 Crankcase separator</p>	 <p>09921-20240 Bearing remover tool</p>	 <p>09923-73210 Bearing remover (15-17 mm)</p>	 <p>09924-84521 Bearing installer set</p>
 <p>09930-30102 Slide shaft</p>	 <p>09930-34980 Rotor remover tool (M33)</p>	 <p>09930-40113 (11F14-008) Sprocket holder</p>	 <p>09940-14911 Steering stem nut socket wrench</p>	 <p>09940-50112 Absorber oil seal installer</p>

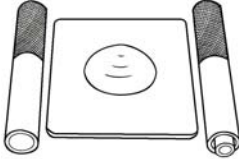
SERVICING INFORMATION

 <p>09940-53311 Bearing installer</p>	 <p>09941-34513 Bearing installer</p>	 <p>09941-54911 Bearing outer race remover</p>	 <p>09941-74910 Bearing installer</p>	
 <p>11F14-001 Rotor holder</p>	 <p>11F14-010 Front absorber tools</p>	 <p>11F14-017 Valve adjust spring</p>	 <p>11F14-018 Valve spring tools</p>	 <p>11F14-019 "T" valve adjust wrench</p>
 <p>11F14-023 Pressure test tool</p>				

TIGHTENING TORQUE

ENGINE

ITEM		N•m	Kg•m
Cylinder head cover bolt		9-10	0.9-1.0
Cylinder head nut		21-25	2.1-2.5
Camshaft sprocket bolt		10-13	1.0-1.3
Crankcase side bolt		8-12	0.8-1.2
Oil drain plug		20-25	2.0-2.5
Primary drive gear nut		40-60	4.0-6.0
Clutch sleeve hub nut		30-50	3.0-5.0
Oil inspection plug		25-35	2.5-3.5
Engine sprocket nut		80-100	0.8-10
Muffler clamp bolt		11-15	1.1-1.5
Tensioner bolt		9-14	0.9-1.4
Camshaft sprocket bolt		10-16	1.0-1.6
Generator rotor nut		30-40	3.0-4.0
Starter clutch bolt		8-12	0.8-1.2
Engine mounting bolt	Upper	33-39	3.3-3.9
	Front	33-39	3.3-3.9
	Rear	33-39	3.3-3.9
Engine hanging bolt	Upper	22-33	2.2-3.3
	Front	22-33	2.2-3.3

CHASSIS

ITEM	N•m	Kg•m
Handlebars clamp bolt	12-20	1.2-2.0
Front absorber upper clamp bolt	20-30	2.0-3.0
Steering stem head bolt	35-55	3.5-5.5
Front absorber lower clamp bolt	25-35	2.5-3.5
Front axle nut	36-52	3.6-5.2
Front brake disc bolt	18-28	1.8-2.8
Air bleeder valve	6-9	0.6-0.9
Front brake caliper bolt	18-28	1.8-2.8
Brake hose union bolt	20-25	2.0-2.5
Master cylinder mounting bolt	8-12	0.8-1.2
Swing arm pivot bolt	50-80	5.0-8.0
Rear absorber mounting nut	22-35	2.2-3.5
Rear axle nut	50-80	5.0-8.0
Rear brake cam rocker bolt	6-8	0.6-0.8
Rear torque link nut (Front and Rear)	10-16	1.0-1.6
Rear sprocket nut	18-28	1.8-2.8
Front footrest bolt	34-50	3.4-5.0

TIGHTENING TORQUE CHART

For other bolts and nuts who's torque is not listed, refer to this chart:

Bolt Diameter Ⓐ (mm)	Conventional or "4" marked bolt		"7" marked bolt	
	N•m	Kg•m	N•m	Kg•m
4	1.5	0.15	2	0.2
5	3	0.3	5	0.5
6	6	0.6	10	1.0
8	13	1.3	23	2.3
10	29	2.9	50	5.0
12	45	4.5	85	8.5
14	65	6.5	135	13.5
16	105	10.5	210	21.0
18	160	16.0	240	24.0

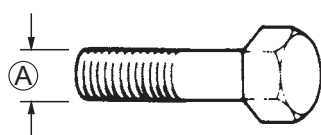

Conventional bolt

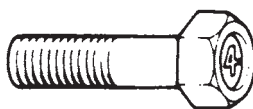

"4" marked bolt

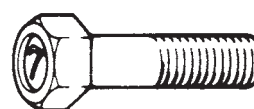

"7" marked bolt

SERVICE DATA**VALVE**

Unit: mm

ITEM	STANDARD		LIMIT
Valve diam.	IN.	25.5	—
	EX.	22.5	—
Valve clearance (when cold)	IN.	0.04-0.07	—
	EX.	0.13-0.18	
Valve guide to valve stem clearance	IN.	0.010-0.037	
	EX.	0.03-0.057	
Valve guide I.D.	IN. & EX.	5.000-5.012	—
Valve stem O.D.	IN.	4.975-4.990	—
	EX.	4.955-4.970	—
Valve stem deflection	IN. & EX.	—	0.35
Valve stem runout	IN. & EX.	—	0.05
Valve head thickness	IN. & EX.	—	0.5
Valve seat width	IN. & EX.	0.9-1.1	—
Valve head radial runout	IN. & EX.	—	0.03
Valve spring free length (IN. & EX.)	Inner	—	31.24
	Outer	—	33.58

CAMSHAFT + CYLINDER HEAD

Unit: mm

ITEM	STANDARD		LIMIT
Cam height	IN.	33.65-33.69	33.35
	EX.	33.30-33.34	33.00
Camshaft journal oil clearance	IN. & EX.	0.021-0.055	0.15
Camshaft journal holder I.D.	IN. & EX.	22.012-22.025	
Camshaft journal O.D.	IN. & EX.	21.970-21.991	
Camshaft runout	IN. & EX.		0.1
Rocker arm I.D	IN. & EX.	12.0-12.018	—
Rocker arm shaft O. D	IN. & EX.	11.977-11.995	—
Cylinder head distortion		—	0.05
Cylinder head cover distortion		—	0.05

CYLINDER + PISTON + PISTON RING

Unit: mm

ITEM	STANDARD		LIMIT
Compression pressure	1 000-1 400 kPa		800 kPa
Piston to cylinder clearance	0.030-0.051		0.12
Cylinder bore	57.010-57.015		57.135
Piston diam.	56.964-56.970 Measure at 8 mm from the skirt end		56.844
Cylinder distortion	—		0.05
Piston ring free end gap	1st	Approx.7.2	5.76
	2nd	Approx.5.8	4.64
Piston ring end gap	1st	0.10-0.25	0.7
	2nd	0.10-0.25	0.7
Piston ring to groove clearance	1st	—	0.18
	2nd	—	0.15
Piston ring groove width	1st	1.01-1.03	—
	2nd	1.01-1.03	—
	Oil	2.01-2.03	—
Piston ring thickness	1st	0.97-0.99	—
	2nd	0.97-0.99	—
Piston pin bore	14.002-14.008		14.030
Piston pin O. D.	13.996-14.000		13.980

CONROD + CRANKSHAFT

Unit: mm

ITEM	STANDARD		LIMIT
Conrod small end I. D.	14.006-14.014		14.04
Conrod deflection	—		
Conrod big end side clearance	0.10-0.45		1.0
Conrod big end width	15.95-16.0		—
Crank pin width	52.7-52.9		—
Crank web to web width	52.9-53.1		0.05
Crank pin O.D.	28.000-28.004		—
Crankshaft runout	—		0.05

OIL PUMP

ITEM	STANDARD		LIMIT
Oil pressure (at 60 °C, 140 °F)	10-30 kPa at 3 000 r/min		—

CLUTCH

Unit: mm

ITEM	STANDARD	LIMIT
Clutch cable play	10-15	—
Drive plate thickness	2.9-3.1	2.4
Drive plate claw width	11.8-12.0	11.3
Driven plate distortion	—	0.1
Clutch spring free length	31	29.45

TRANSMISSION + DRIVE CHAIN

ITEM	STANDARD		LIMIT
Primary reduction ratio	3.470 (59/17)		—
Final reduction ratio	2.867 (43/15)		—
Gear ratios	Low	3.000 (33/11)	—
	2nd	1.857 (26/14)	—
	3rd	1.368 (26/19)	—
	4th	1.095 (23/21)	—
	Top	0.957 (22/23)	—
Shift fork to groove clearance	0.10-0.30		
Shift fork groove width	No.1 & No.2	5.1	
	No.3	5.5-5.6	
Shift fork thickness	No.1 & No.2	4.8-4.9	
	No.3	5.3-5.4	—
Countershaft length (Low to 2nd)	79.8-88.1		—
Drive chain	Type	KMC428HG	—
	Links	116	—
	20 pitch length	—	259.0 mm
Drive chain slack	10-20 mm		—

CARBURETOR

ITEM	SPECIFICATION	ITEM	SPECIFICATION
Carburetor type	BS26	Bubbling jet ①	∅ 3
I.D. No.	054G	Main jet ②	# 110
Needle ③	4DH41-2	Idle air screw ④	2,5/8 turn out
Needle jet ⑤	P-0(390)	Idle air jet ⑥	# 1.25
Idle jet ⑦	# 12.5	Idle	1400±100 r/min

ELECTRICAL

ITEM		SPECIFICATION		NOTE
Spark plug	Type	NGK CR8E		
	Gap	0.7 mm-0.8 mm		
Ignition coil resistance	Primary	4±15% Ω		Terminal - Ground or Terminal - Terminal
	Secondary	13000±20% Ω		Plug cap - Terminal or Plug cap - Plug cap
Generator coil resistance	Trigger	Approx.110 Ω		BI-G
	Charging	Approx.0.9 Ω		Y-Y
Generator no-load voltage		More than 75.5-80V at 5000 r/min		
Regulate voltage		14.6-15.4V at 5 000 r/min		
Battery	Type designation	12N7-4A		
	Capacity	12 V7Ah		
	Standard electrolyte S. G.	1.28±0.01 (20°C)		
Fuse		15 A		

LIGHT

ITEM		SPECIFICATION	ITEM	SPECIFICATION
Headlight	HI	35 W	Dashboard light	2 W
	LO	35 W	High beam indicator light	2 W
Tail/Brake light		5/21 W	Turn signal indicator light	3 W
Turn signal light		10 W	Gear indication light	2 W
Position light		5 W		

TIRE

ITEM	SPECIFICATION		LIMIT
Cold inflation tire pressure (Solo riding)	FRONT	175 kPa(1.75 kgf/cm ²)	—
	REAR	200 kPa(2.00 kgf/cm ²)	—
Cold inflation tire pressure (Dual riding)	FRONT	175 kPa(1.75 kgf/cm ²)	—
	REAR	225 kPa(2.25 kgf/cm ²)	—
Tire size	FRONT	2.75-18 4PR	—
	REAR	3.50-16 4PR	—

BRAKE + WHEEL

Unit: mm

ITEM	STANDARD		LIMIT
Rear brake pedal height	20-30		—
Brake disc thickness	Front	3.8-4.2	3.0
Brake disc runout	—		0.3
Brake fluid type	Dot 4		—
Brake drum I. D.	—		130.7
Brake lining thickness	—		1.5
Wheel rim runout	Front	—	2.0
	Rear	—	2.0
Wheel axle runout	Front	—	0.25
	Rear	—	0.25

SUSPENSION

Unit: mm

ITEM	STANDARD	LIMIT
Front fork stroke	130	—
Front fork spring free length	385.5	
Fork fork oil type	SUZUKI fork oil #32 or equivalent fork oil	—
Front fork oil capacity(each leg)	168±3 ml	—
Rear suspension spring adjustment	2nd	—
Swing arm pivot shaft runout	—	0.6

FUEL + OIL

ITEM	STD/SPEC.		NOTE
Fuel type	Fuel used should be graded 91 octane or higher. An unleaded fuel is recommended.		
Fuel tank capacity	Including reserve	10 L	
	Reserve	2 L	
Engine oil type and grade	SAE 10W-40, API SF or SG		
Engine oil capacity	Oil change	850 ml	
	Filter change	950 ml	
	Overhaul	1 300 ml	

SERVICING INFORMATION

WIRING DIAGRAM

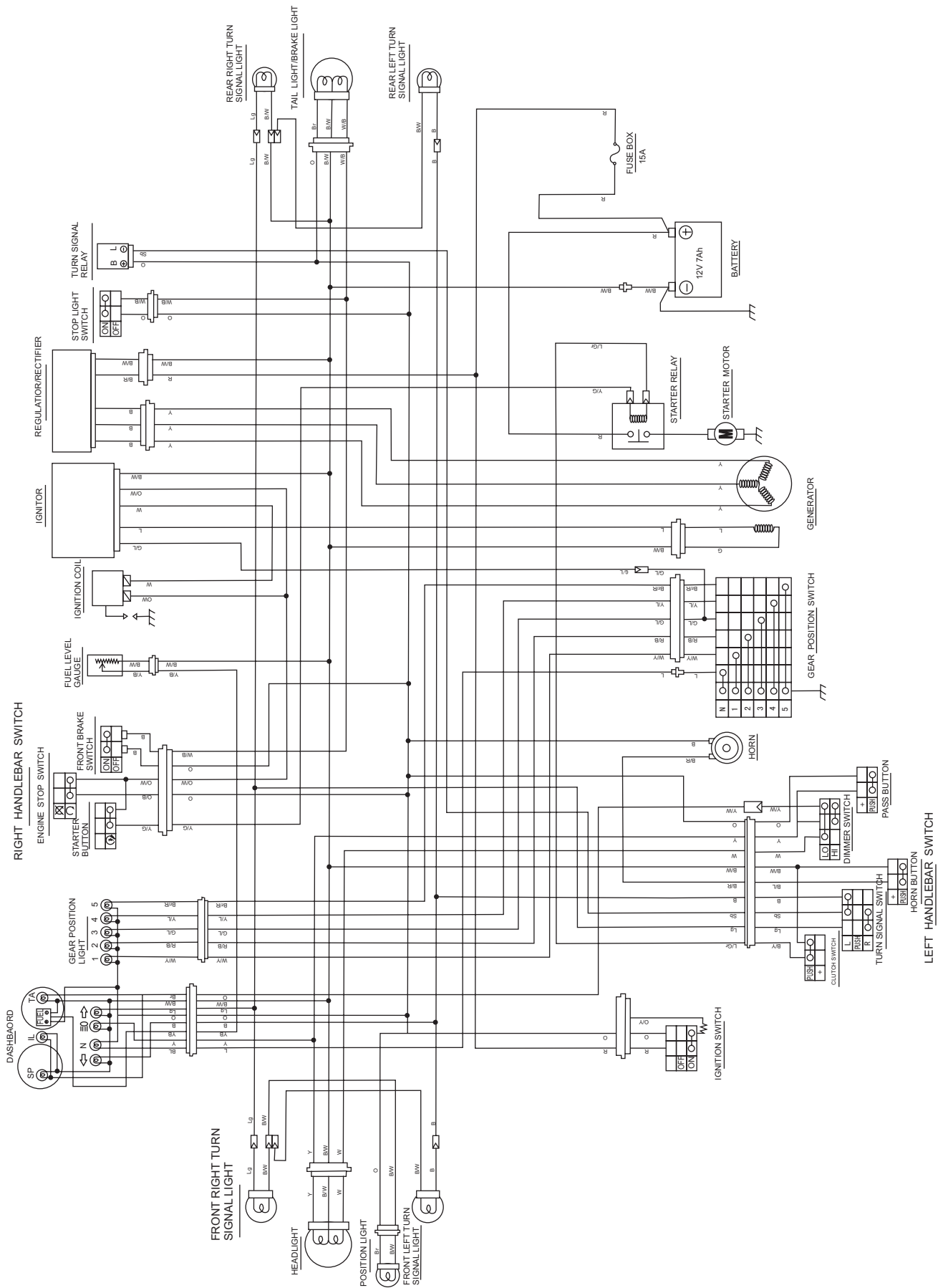

JIANG MEN DACHANGJIANG GROUP CO., LTD
Customer service department
1st Ed. DEC, 2014
Printed in China

SUZUKI MOTOR CORPORATION
JIANGMEN DACHANGJIANG GROUP CO., LTD.