

Tech-CD

Service & Repair Manual

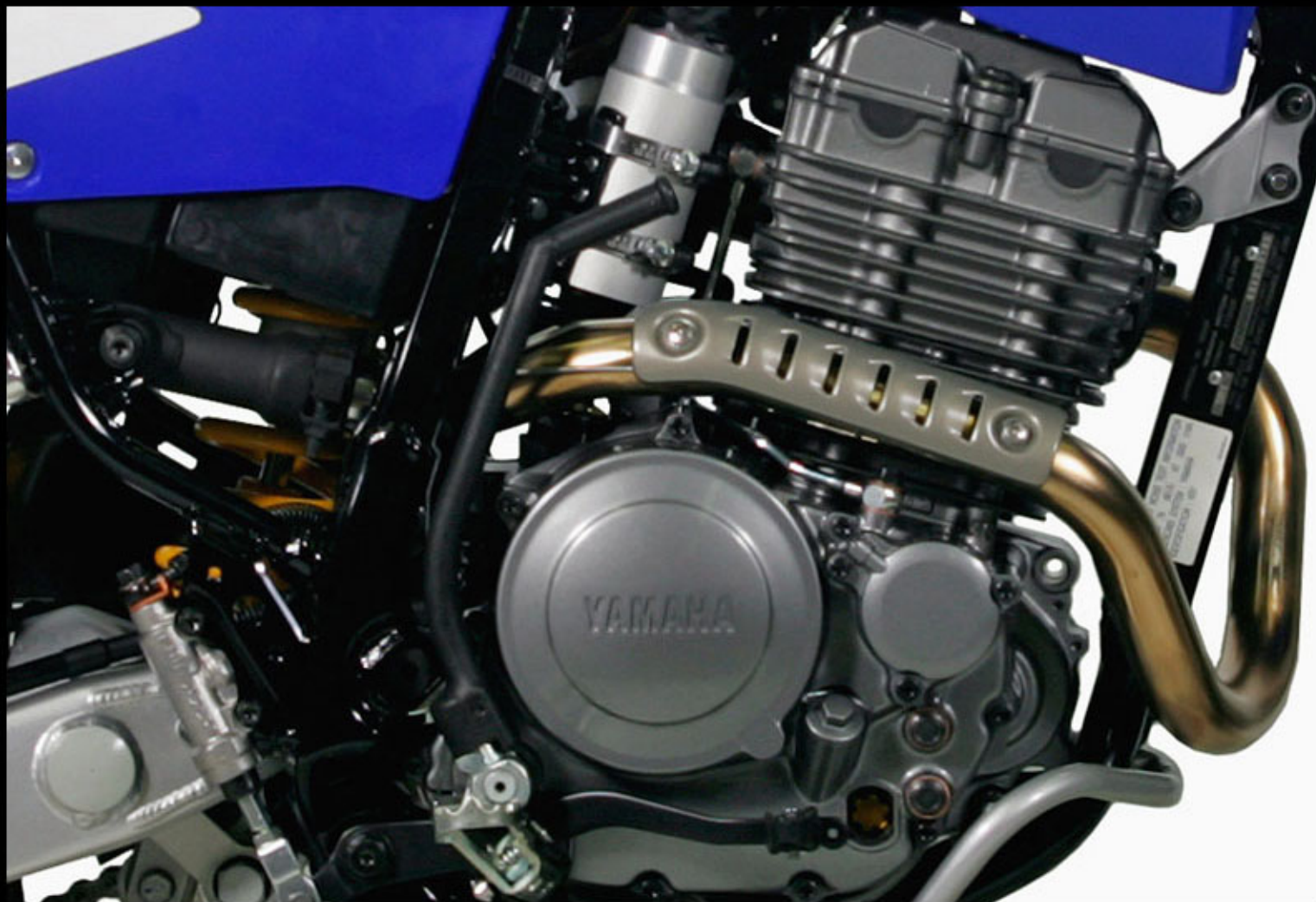

















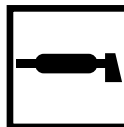

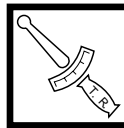

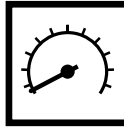
TTR250
Service Manual
1999-2006

ILLUSTRATED SYMBOLS

Illustrated symbols ① to ⑧ are printed on the top right of each page and indicate the subject of each chapter.

- ① General information
- ② Specifications
- ③ Periodic inspections and adjustments
- ④ Engine overhaul
- ⑤ Carburetor
- ⑥ Chassis
- ⑦ Electrical
- ⑧ Troubleshooting

① GEN INFO 	② SPEC 	
③ INSP ADJ 	④ ENG 	
⑤ CARB 	⑥ CHAS 	
⑦ ELEC 	⑧ TRBL SHTG ?	
⑨ 	⑩ 	
⑪ 	⑫ 	
⑬ 	⑭ 	⑮ 
⑯ 	⑰ 	⑱ 
⑲ 	⑳ 	㉑ 
㉒ 	㉓ New	

Illustrated symbols ⑨ to ⑮ are used to identify the specifications appearing in the text.

- ⑨ Filling fluid
- ⑩ Lubricant
- ⑪ Special tool
- ⑫ Torque
- ⑬ Wear limit, clearance
- ⑭ Engine speed
- ⑮ Ω , V, A

Illustrated symbols ⑯ to ㉑ in the exploded diagrams indicate the types of lubricants and lubrication points.

- ⑯ Apply engine oil
- ⑰ Apply gear oil
- ⑱ Apply molybdenum disulfide oil
- ⑲ Apply wheel bearing grease
- ⑳ Apply lightweight lithium-soap base grease
- ㉑ Apply molybdenum disulfide grease

Illustrated symbols ㉒ to ㉓ in the exploded diagrams indicate where to apply a locking agent ㉒ and when to install a new part ㉓.

- ㉒ Apply the locking agent (LOCTITE®)
- ㉓ Replace

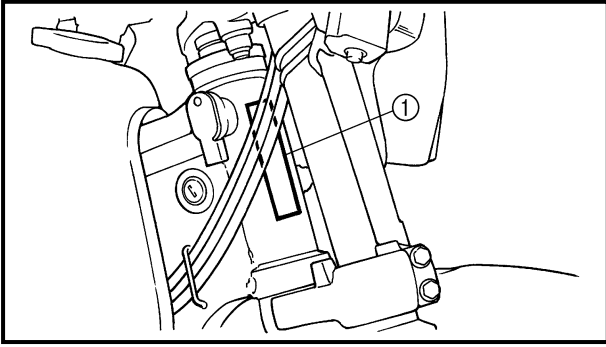

GENERAL INFORMATION

MOTORCYCLE IDENTIFICATION

VEHICLE IDENTIFICATION NUMBER

The vehicle identification number ① is stamped into the right side of the steering head.

NOTE: _____

The vehicle identification number is used to identify your motorcycle and may be used to register your motorcycle with the licensing authority in your state.

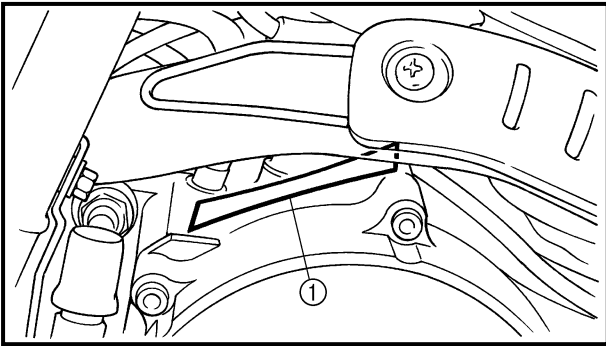

ENGINE SERIAL NUMBER

The engine serial number ① is stamped into the elevated part of the right rear section of the engine.

NOTE: _____

- The first three digits of these numbers are for model identifications; the remaining digits are the unit production number.
- Designs and specifications are subject to change without notice.



1

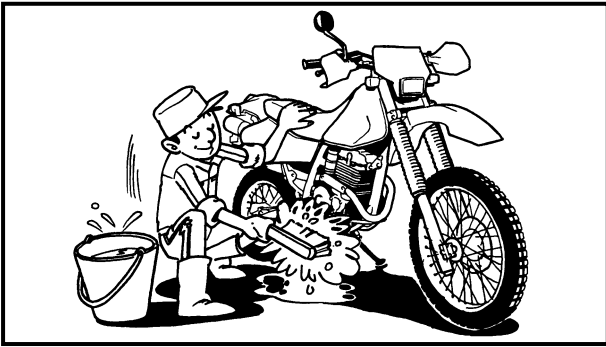

**IMPORTANT INFORMATION
PREPARATION FOR REMOVAL AND
DISASSEMBLY**

1. Remove all dirt, mud, dust, and foreign material before removing and disassembling.

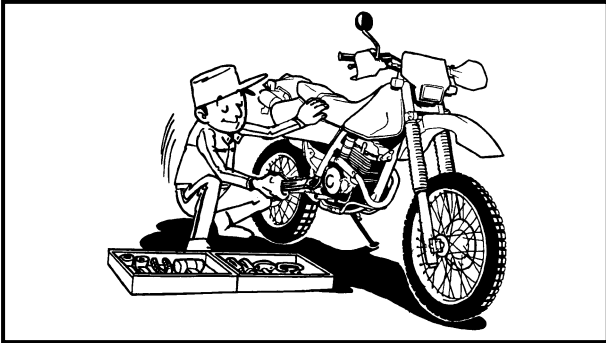

2. Use proper tools and cleaning equipment. Refer to "SPECIAL TOOLS".



3. When disassembling the motorcycle keep mated parts together. This includes gears, cylinder, piston and other mated parts that have been "mated" through normal wear. Mated parts must be reused as an assembly or replaced.

4. During the motorcycle disassembly, clean all parts and place them in trays in the order of disassembly. This will speed up assembly time and help assure that all parts are correctly reinstalled.

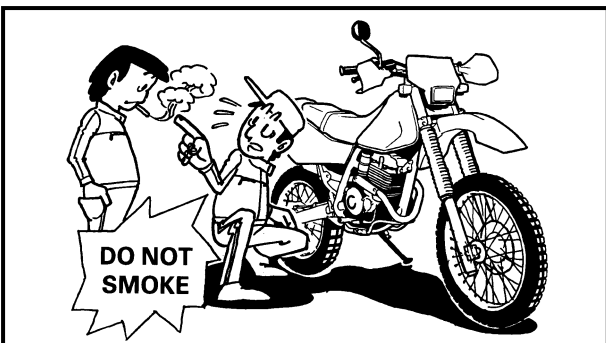

5. Keep away from fire.

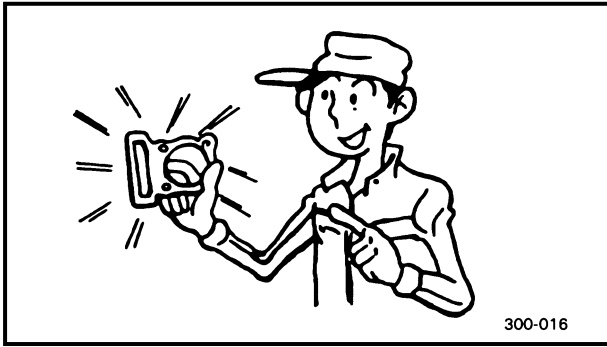

ALL REPLACEMENT PARTS

1. Use only genuine Yamaha parts for all replacements. Use oil and/or grease recommended by Yamaha for assembly and adjustment. Other brands may be similar in function and appearance, but inferior in quality.

GASKETS, OIL SEALS, AND O-RINGS

1. All gaskets, seals and O-rings should be replaced when an engine is overhauled. All gasket surfaces oil seal lips and O-rings must be cleaned.

2. Properly oil all mating parts and bearings during reassembly. Apply grease to the oil seal lips.

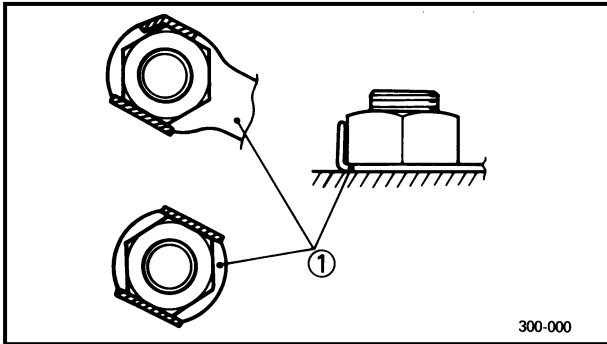

LOCK WASHERS/PLATES AND COTTER PINS

1. All lock washers/plates ① and cotter pins must be replaced when they are removed. Lock tab(s) should be bent along the bolt or nut flat(s) after the bolt or nut has been properly tightened.

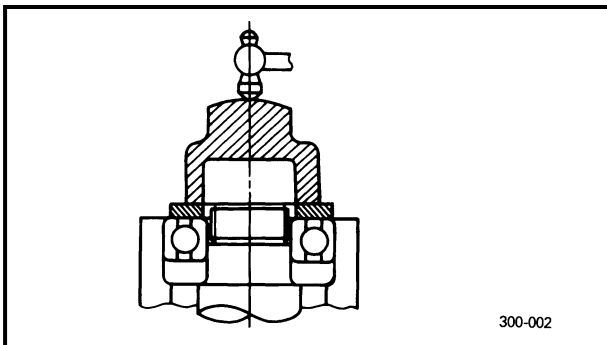

BEARINGS AND OIL SEALS

1. Install the bearing(s) ① and oil seal(s) ② with their manufacturer's marks or numbers facing outward. (In other words, the stamped letters must be on the side exposed to view.) When installing oil seal(s), apply a light coating of light-weight lithium base grease to the seal lip(s). Oil the bearings liberally when installing.

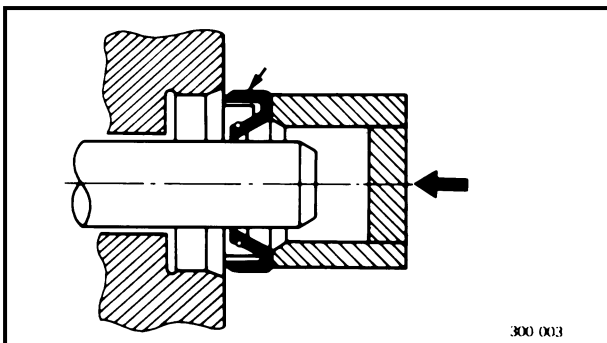

Do not use compressed air to spin the bearings dry. This causes damage to the bearing surfaces.

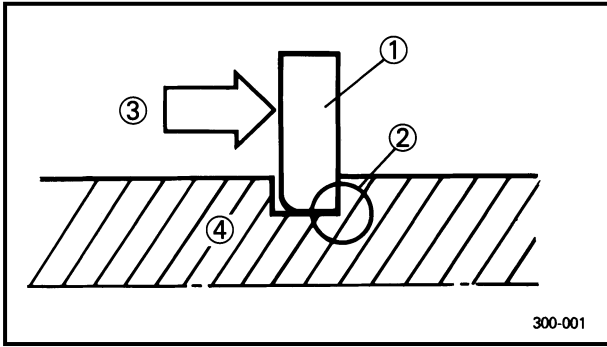

CIRCLIPS

1. All circlips should be inspected carefully before reassembly. Always replace piston pin clips after one use. Replace distorted circlips. When installing a circlip ①, make sure that the sharp-edged corner ② is positioned opposite to the thrust ③ it receives. See the sectional view.

④ Shaft

SPECIAL TOOLS

The proper special tools are necessary for complete and accurate tune-up and assembly. Using the correct special tool will help prevent damage caused by the use of improper tools or improvised techniques.

FOR TUNE UP

1
Steering nut wrench
P/N. YU-33975

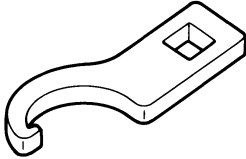

This tool is used to adjust the spring preload of rear shock absorber.

2
Inductive tachometer
P/N. YU-8036-A

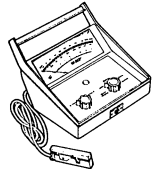

This tool is needed for detecting engine r/min.

3
Inductive timing light
P/N. YM-33277-A

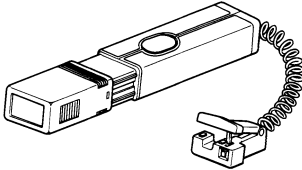

This tool is necessary for checking ignition timing.

4
Compression gauge
P/N. YU-33223
Adapter (M12)
P/N. YU-33223-3

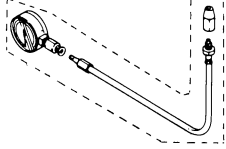

These gauges are used to measure the engine compression.

5
Fuel level gauge
P/N. YM-01312-A

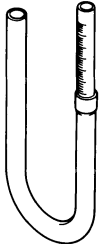

This gauge is used to measure the fuel level in the float chamber.



FOR ENGINE SERVICE

1

Piston pin puller
P/N. YU-01304

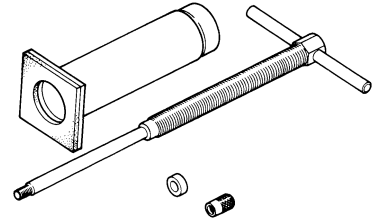

This tool is used to remove the piston pin.

2

Sheave holder
P/N. YS-01880

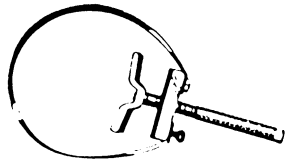

This tool is used to hold the rotor when removing or installing the rotor securing nut.

3

Rotor puller
P/N. 2K7-85555-00

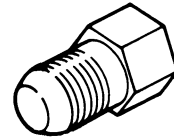

This tool is used to remove the rotor.

4

Universal clutch holder
P/N. YM-91042

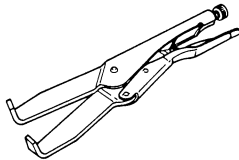

This tool is used to hold the clutch when removing or installing the clutch boss locknut.

5

Crankcase separating tool
P/N. YU-01135-A

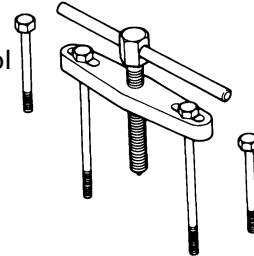

This tool is necessary to remove the crankshaft.

6

Valve spring compressor
P/N. YM-04019

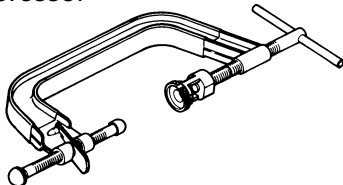

This tool is needed to remove and install the valve assemblies.

7

Valve seat cutter set
P/N. YM-91043

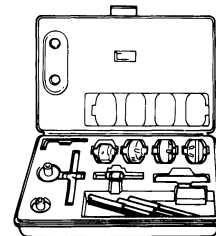

This tool is needed to resurface the valve seat.

8

Valve guide remover 5 mm (0.20 in)
P/N. YM-04097

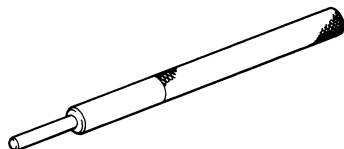

This tool is used to remove the valve guides.

9

Valve guide reamer 5 mm (0.20 in)
P/N. YM-04099

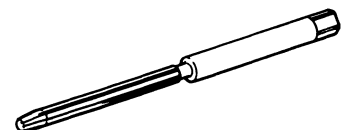

This tool is used to rebore the new valve guide.



10
Valve guide installer 5 mm (0.20 in)
P/N. YM-04098

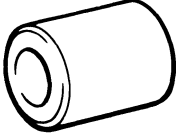

This tool is needed to install the valve guides properly.

11
Crankshaft installing set
P/N. YU-90050

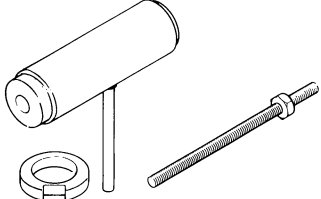

These tools are used to install the crankshaft.

12
Adapter (M10)
P/N. YU-90062

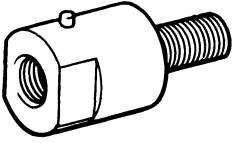

This tool is used to install the crankshaft.

13
Crank pot spacer
P/N. YU-01202



This tool is used to install the crankshaft.

14
Quick Gasket®
P/N. ACC-11001-05-01

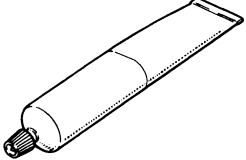

This sealant (bond) is used for crankcase mating surfaces, etc.

FOR CHASSIS SERVICE

1
Damper rod holder
P/N. YM-01418

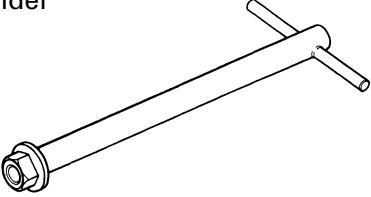

This tool is used to loosen and tighten the damper rod holding bolt.

2
Front fork seal drive weight
P/N. YM-33963-①
Adapter 43 mm (1.69 in)
P/N. YM-8020-②

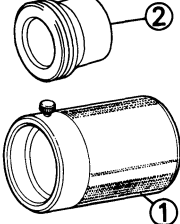

These tools are used when installing the fork oil seal.

3
Rod holder
P/N. YM-01434

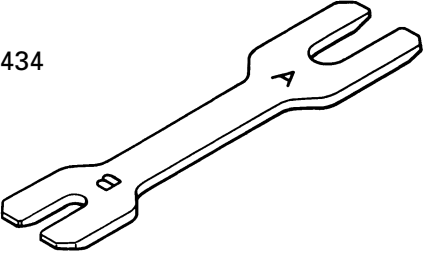

This tool is used to hold the fork spring.

4
Rod puller attachment (M10)
P/N. 90890-01436

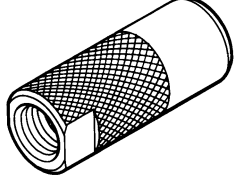

This tool is used to pull up the fork damper rod.



5

Rod puller
P/N. YM-01437

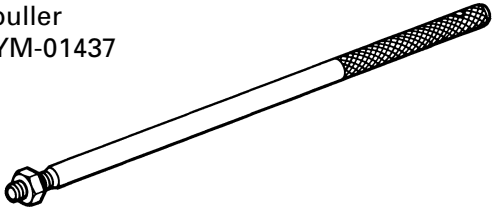

This tool is used to pull up the fork damper

6

Cylinder cup installer
P/N. 90890-01996

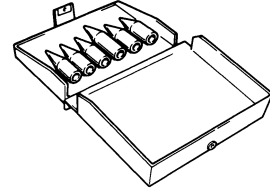

This tool is used to install the master cylinder kit.

7

Drive chain cutter
P/N. YM-33858

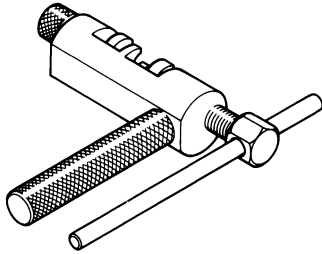

This tool is used to cut and join the drive chain.

FOR ELECTRICAL COMPONENTS

1

Dynamic spark tester
P/N. YM-34487

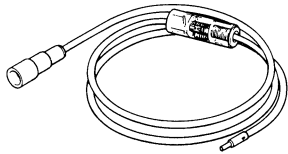

This instrument is necessary for checking the ignition system components.

2

Pocket tester
P/N. YU-03112

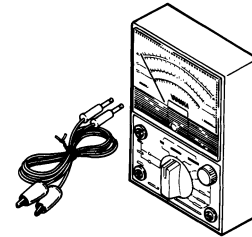

This instrument is used for checking the electrical system.



SPECIFICATIONS

GENERAL SPECIFICATIONS

Model	TTR250L(C)
Model code:	5GF1 5GF2
Dimensions:	
Overall length	2,095 mm (82.5 in)
Overall width	835 mm (32.9 in)
Overall height	1,260 mm (49.6 in)
Seat height	915 mm (36.0 in)
Wheelbase	1,405 mm (55.3 in)
Minimum ground clearance	305 mm (12.0 in)
Minimum turning radius	2,200 mm (86.6 in)
Basic weight:	
With oil and full fuel tank	124 kg (273 lb)
Engine:	
Engine type	Air-cooled 4-stroke, DOHC
Cylinder arrangement	Forward-inclined single cylinder
Displacement	249 cm ³
Bore × stroke	73.0 × 59.6 mm (2.87 × 2.35 in)
Compression ratio	10.2 : 1
Compression pressure (STD)	1,200 kPa (12 kg/cm ² , 174 psi) at 300 r/min
Starting system	Electric starter
Lubrication system	Wet sump
Oil type or grade:	
Engine oil	
	SAE 20W40 type SE motor oil SAE 10W30 type SE motor oil
Oil capacity:	
Engine oil	
Periodic oil change	1.10 L (0.97 Imp qt, 1.16 US qt)
With oil filter replacement	1.20 L (1.06 Imp qt, 1.27 US qt)
Total amount	1.45 L (1.28 Imp qt, 1.53 US qt)
Air filter:	Wet type element
Fuel:	
Type	Unleaded fuel only
Fuel tank capacity	10 L (2.20 Imp gal, 2.64 US gal)
Fuel reserve amount	2 L (0.44 Imp gal, 0.53 US gal)



Model	TTR250L(C)
Carburetor: Type / quantity Manufacturer	Y30P/1 TEIKEI
Spark plug: Type Manufacturer Spark plug gap	CR9E/U27ESR-N NGK/DENSO 0.7 ~ 0.8 mm (0.028 ~ 0.031 in)
Clutch type:	Wet, multiple-disc
Transmission: Primary reduction system Primary reduction ratio Secondary reduction system Secondary reduction ratio Transmission type Operation Gear ratio	Spur gear 74/24 (3.083) Chain drive 52/13 (4.000) Constant mesh 6-speed Left foot operation 1st 37/15 (2.466) 2nd 29/16 (1.812) 3rd 30/22 (1.363) 4th 27/25 (1.080) 5th 24/27 (0.888) 6th 22/29 (0.758)
Chassis: Frame type Caster angle Trail	Semi double cradle 26° 108 mm (4.25 in)
Tire: Type Size Manufacturer Type	With tube front 80/100-21 51M rear 100/100-18 59M front DUNLOP rear DUNLOP front D739F rear D739
Tire pressure (cold tire): Maximum load-except motorcycle* Off-road riding*	90 kg (198 lb) front 100 kPa (1 kg/cm ² , 14.5 psi) rear 100 kPa (1 kg/cm ² , 14.5 psi)
*Load is total weight of rider, and accessories.	

GENERAL SPECIFICATIONS

SPEC



Model	TTR250L(C)
Brake: Front brake type operation Rear brake type operation	Single disc brake Right hand operation Single disc brake Right foot operation
Suspension: Front suspension Rear suspension	Telescopic fork Swingarm (link suspension)
Shock absorber: Front shock absorber Rear shock absorber	Coil-air spring / oil damper Coil spring / gas-oil damper
Wheel travel: Front wheel travel Rear wheel travel	280 mm (11.0 in) 280 mm (11.0 in)
Electrical: Ignition system Generator system Battery type Battery capacity	C.D.I. A.C. magneto generator GT7B-4 12 V 6.5 AH
Headlight type:	Quartz bulb (Halogen)
Bulb wattage × quantity: Headlight Tail light	12 V 35 W/36.5 W 12 V 5 W/21 W

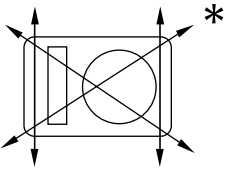
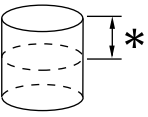
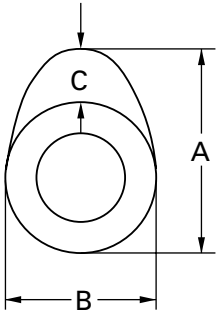
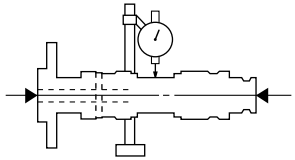

**MAINTENANCE SPECIFICATIONS
ENGINE**

Model	TTR250L(C)
<p>Cylinder head: Volume <Warp limit></p> 	<p>21.6 ~ 22.2 cm³ <0.03 mm (0.0012 in)> *Lines indicate straightedge measurement.</p>
<p>Cylinder: Material Sleeve type Bore size *Measuring point <Wear limit> <Warp limit></p> 	<p>Aluminum alloy Sleeveless, surface honing 72.97 ~ 73.02 mm (2.8728 ~ 2.8748 in) 40 mm (1.57 in) <73.1 mm (2.8779 in)> <0.03 mm (0.0012 in)></p>
<p>Camshaft: Drive method Cam cap inside diameter Camshaft outside diameter Shaft-to-cap clearance Cam dimensions Intake Exhaust Camshaft runout limit Camshaft oil clearance <Limit></p>  	<p>Chain drive (right) 24.500 ~ 24.521 mm (0.9646 ~ 0.9654 in) 24.467 ~ 24.480 mm (0.9633 ~ 0.9638 in) 0.020 ~ 0.054 mm (0.0008 ~ 0.0021 in) Intake "A" <limit> 32.75 ~ 32.85 mm (1.2894 ~ 1.2933 in) <32.7 mm (1.287 in)> "B" <limit> 25.0 ~ 25.1 mm (0.9843 ~ 0.9882 in) <24.96 mm (0.983 in)> "C" 7.8 mm (0.3071 in) Exhaust "A" <limit> 32.75 ~ 32.85 mm (1.2894 ~ 1.2933 in) <32.7 mm (1.287 in)> "B" <limit> 25.0 ~ 25.1 mm (0.9843 ~ 0.9882 in) <24.96 mm (0.983 in)> "C" 7.8 mm (0.3071 in) Camshaft runout limit 0.03 mm (0.0012 in) Camshaft oil clearance 0.020 ~ 0.054 mm (0.0008 ~ 0.0021 in) <0.08 mm (0.0031 in)></p>
<p>Cam chain: Cam chain type / No. of links Cam chain adjustment method</p>	<p>82RH2010-122M/122 Automatic</p>

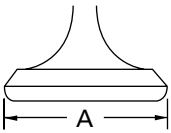
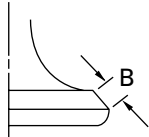
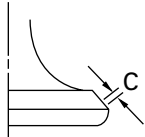
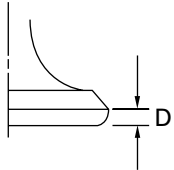
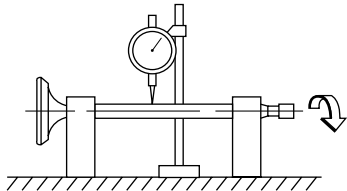

Model	TTR250L(C)	
Valve, valve seat, valve guide:		
Valve clearance (cold)	IN	0.09 ~ 0.19 mm (0.004 ~ 0.007 in)
	EX	0.19 ~ 0.27 mm (0.007 ~ 0.011 in)
Valve dimensions:		
		
		
Head Diameter	Face Width	Seat Width
		Margin Thickness
"A" head diameter	IN	28.4 ~ 28.6 mm (1.118 ~ 1.126 in)
	EX	23.9 ~ 24.1 mm (0.941 ~ 0.949 in)
"B" face width	IN	2.26 mm (0.089 in)
	EX	2.26 mm (0.089 in)
"C" seat width	IN	0.9 ~ 1.1 mm (0.035 ~ 0.043 in)
	EX	0.9 ~ 1.1 mm (0.035 ~ 0.043 in)
"D" margin thickness	IN	0.6 ~ 1.0 mm (0.024 ~ 0.039 in)
	EX	0.8 ~ 1.2 mm (0.031 ~ 0.047 in)
Stem outside diameter	IN	4.975 ~ 4.990 mm (0.1959 ~ 0.1965 in)
	EX	4.960 ~ 4.975 mm (0.1953 ~ 0.1959 in)
<Limit>	IN	<4.95 mm (0.195 in)>
	EX	<4.94 mm (0.194 in)>
Guide inside diameter	IN	5.000 ~ 5.012 mm (0.1969 ~ 0.1973 in)
	EX	5.000 ~ 5.012 mm (0.1969 ~ 0.1973 in)
<Limit>	IN	<5.03 mm (0.198 in)>
	EX	<5.03 mm (0.198 in)>
Stem-to-guide clearance	IN	0.010 ~ 0.037 mm (0.0004 ~ 0.0015 in)
	EX	0.025 ~ 0.052 mm (0.0010 ~ 0.0020 in)
<Limit>	IN	<0.08 mm (0.003 in)>
	EX	<0.1 mm (0.004 in)>
<Stem runout limit>		<0.01 mm (0.0004 in)>
		
Valve face material		Stellite
Valve seat width	IN	0.9 ~ 1.1 mm (0.0354 ~ 0.0433 in)
	EX	0.9 ~ 1.1 mm (0.0354 ~ 0.0433 in)
<Limit>	IN	<1.6 mm (0.06 in)>
	EX	<1.6 mm (0.06 in)>

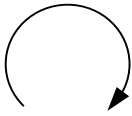
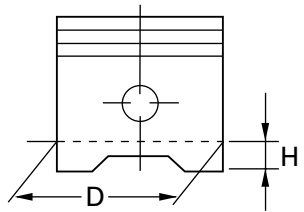

Model	TTR250L(C)	
<p>Valve spring:</p> <p>Free length</p> <p><Limit></p> <p>Spring rate</p> <p>Set length (valve closed)</p> <p>Compressed pressure (installed)</p> <p><Tilt limit></p> <p>Direction of winding (top view)</p> <p>Valve lifter outside diameter</p> <p><Limit></p>	<p>IN</p> <p>EX</p> <p>IN</p> <p>EX</p> <p>IN-K1</p> <p>IN-K2</p> <p>EX-K1</p> <p>EX-K2</p> <p>IN</p> <p>EX</p> <p>IN</p> <p>EX</p> <p>IN</p> <p>EX</p> <p>IN</p> <p>IN</p> <p>35.59 mm (1.40 in)</p> <p>35.59 mm (1.40 in)</p> <p><33.81 mm (1.33 in)></p> <p><33.81mm (1.33 in)></p> <p>18.9 N/mm (1.93 kg/mm, 107.92 lb/in)</p> <p>24.5 N/mm (2.50 kg/mm, 139.9 lb/in)</p> <p>18.9 N/mm (1.93 kg/mm, 107.92 lb/in)</p> <p>24.5 N/mm (2.50 kg/mm, 139.9 lb/in)</p> <p>30.39 mm (1.2 in)</p> <p>30.39 mm (1.2 in)</p> <p>9.3 ~ 10.7 kg (20.50 ~ 23.58 lb)</p> <p>9.3 ~ 10.7 kg (20.50 ~ 23.58 lb)</p> <p><2.5° / 1.6 mm (2.5° / 0.063 in)></p> <p><2.5° / 1.6 mm (2.5° / 0.063 in)></p> <p>Clockwise</p> <p>Clockwise</p>  <p>22.476 ~ 22.500 mm (0.88 ~ 0.89 in)</p> <p><22.451 mm (0.88 in)></p>	
<p>Piston:</p> <p>Piston part number</p> <p>Piston to cylinder clearance</p> <p><Limit></p> <p>Piston size "D"</p>  <p>Measuring point "H"</p> <p>Piston off-set</p> <p>Piston off-set direction</p> <p>Piston pin bore inside diameter</p> <p><Limit></p> <p>Piston pin outside diameter</p> <p><Limit></p>	<p>4GY-11631-00</p> <p>0.04 ~ 0.06 mm (0.0016 ~ 0.0024 in)</p> <p><0.15 mm (0.0059 in)></p> <p>72.92 ~ 72.97 mm (2.8709 ~ 2.8728 in)</p> <p>1 mm (0.039 in)</p> <p>0.5 mm (0.020 in)</p> <p>In side</p> <p>18.004 ~ 18.015 mm (0.7088 ~ 0.7093 in)</p> <p><18.045 mm (0.71 in)></p> <p>17.991 ~ 18.000 mm (0.7083 ~ 0.7087 in)</p> <p><17.976 mm (0.71 in)></p>	

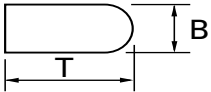
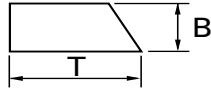
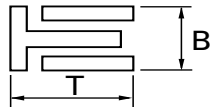
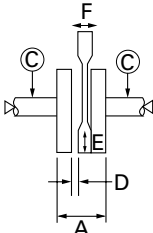

Model	TTR250L(C)
<p>Piston rings:</p> <p>Top ring</p> <p>Type </p> <p>Dimensions (B × T)</p> <p>End gap (installed) <Limit></p> <p>Side clearance (installed) <Limit></p> <p>Plating/coating</p> <p>2nd ring:</p> <p>Type </p> <p>Dimensions (B × T)</p> <p>End gap (installed) <Limit></p> <p>Side clearance <Limit></p> <p>Plating/coating</p> <p>Oil ring:</p> <p>Dimensions (B × T) </p> <p>End gap (installed)</p> <p>Side clearance</p> <p>Plating/coating</p>	<p>Barrel</p> <p>1.0 × 3.1 mm (0.039 × 0.122 in)</p> <p>0.20 ~ 0.35 mm (0.008 ~ 0.014 in)</p> <p><0.4 mm (0.016 in)></p> <p>0.04 ~ 0.08 mm (0.0016 ~ 0.0031 in)</p> <p><0.12 mm (0.005 in)></p> <p>Chrome plated/parkerizing</p> <p>Taper</p> <p>1.0 × 3.1 mm (0.039 × 0.122 in)</p> <p>0.20 ~ 0.35 mm (0.008 ~ 0.014 in)</p> <p><0.4 mm (0.016 in)></p> <p>0.03 ~ 0.07 mm (0.001 ~ 0.003 in)</p> <p><0.12 mm (0.005 in)></p> <p>Parkerizing</p> <p>2.0 × 2.5 mm (0.079 × 0.098 in)</p> <p>0.2 ~ 0.7 mm (0.008 ~ 0.028 in)</p> <p>0.060 ~ 0.155 mm (0.002 ~ 0.006 in)</p> <p>Chrome plated/parkerizing</p>
<p>Connecting rod:</p> <p>Connecting rod length</p>	<p>102.4 ~ 102.6 mm (4.03 ~ 4.04 in)</p>
<p>Crankshaft:</p> <p>Crank width "A" <Runout limit "C"></p> <p>Big end side clearance "D"</p> <p>Big end radial clearance "E"</p> <p>Small end free play "F"</p> 	<p>60.25 ~ 60.30 mm (2.372 ~ 2.374 in)</p> <p><0.03 mm (0.0012 in)></p> <p>0.35 ~ 0.85 mm (0.014 ~ 0.033 in)</p> <p>0.010 ~ 0.025 mm (0.0004 ~ 0.0010 in)</p> <p>0.8 mm (0.0315 in)</p>
<p>Balancer:</p> <p>Balancer drive method</p>	<p>Gear</p>
<p>Clutch:</p> <p>Friction plate thickness Quantity <Friction plate wear limit></p> <p>Clutch plate thickness Quantity <Warp limit></p> <p>Clutch spring free length Quantity Minimum length</p> <p>Clutch housing thrust clearance</p> <p>Clutch housing radial clearance</p>	<p>2.9 ~ 3.1 mm (0.114 ~ 0.122 in)</p> <p>7 pcs</p> <p><2.7 mm (0.11 in)></p> <p>1.5 ~ 1.7 mm (0.059 ~ 0.067 in)</p> <p>6 pcs</p> <p><0.05 mm (0.002 in)></p> <p>42.8 mm (1.69 in)</p> <p>5 pcs</p> <p>40.8 mm (1.61 in)</p> <p>0.08 ~ 0.33 mm (0.003 ~ 0.013 in)</p> <p>0.010 ~ 0.044 mm (0.0004 ~ 0.0017 in)</p>



Model	TTR250L(C)
Clutch release method <Push rod bending limit>	Inner push, cam push <0.5 mm (0.020 in)>
Transmission: <Main axle deflection limit> <Drive axle deflection limit>	<0.08 mm (0.003 in)> <0.08 mm (0.003 in)>
Shifter: Shifter type Shift fork thickness	Cam drum and guide bar 4.76 ~ 4.89 mm (0.1874 ~ 0.1925 in)
Air filter oil grade:	Foam-air-filter oil or SAE 10W30 type SE motor oil
Carburetor: I.D. mark Main jet (M.J) Main air jet (M.A.J) Jet needle (J.N) Needle jet (N.J) Cutaway (C.A) Pilot air jet (P.A.J.1) Pilot outlet (P.O) Pilot jet (P.J) Bypass 1 (B.P.1) Pilot screw (P.S) Valve seat size (V.S) Starter jet (G.S.1) Starter jet (G.S.2) Float height (F.H) Fuel level (F.L) Engine idle speed Intake vacuum Oil temperature	5GF1 00 #137 1.0 5C9C-3/5 2.595 (V95) 4.0 1.2 0.8 #52 1.0 × 2 1-1/2 2.0 #66 2.0 26.5 ~ 27.5 mm (1.04 ~ 1.08 in) 7.5 ~ 9.5 mm (0.30 ~ 0.37 in) 1,250 ~ 1,350 r/min 24.0 ~ 29.3 kPa (180 ~ 220 mmHg, 7.087 ~ 8.652 inHg) 55 ~ 65 °C (131 ~ 149 °F)
Lubrication system: Oil filter type Oil pump type Tip clearance "A" or "B" <Limit> Side clearance <Limit> Housing and rotor clearance <Limit> Oil pressure (hot) Pressure check location	Wire mesh type Trochoid type 0.15 mm (0.006 in) <0.2 mm (0.008 in)> 0.10 ~ 0.15 mm (0.004 ~ 0.006 in) <0.2 mm (0.008 in)> 0.04 ~ 0.09 mm (0.002 ~ 0.004 in) <0.15 mm (0.006 in)> 100 kPa (1 kg/cm ² , 14.22 psi) at 1,300 r/min Crankcase cover 3



TIGHTENING TORQUES

Part to be tightened	Part name	Thread size	Q'ty	Tightening torque			Remarks
				Nm	m.kg	ft.lb	
Cylinder head (camshaft cap)	Flange bolt	M6	8	10	1.0	7.2	
Spark plug	-	M10S	1	13	1.3	9.4	
Cylinder head (exhaust pipe)	Stud bolt	M10	2	20	2.0	14	
Cylinder head	Flange bolt	M10	4	40	4.0	29	
Cylinder head	Flange bolt	M6	2	10	1.0	7.2	
Cylinder head	Nut	M8	2	20	2.0	14	
Cylinder head cover	Bolt	M6	3	10	1.0	7.2	
Flywheel magneto	Flange bolt	M10	1	60	6.0	43	
Camshaft sprocket	Flange bolt	M7	4	24	2.4	17	
Camshaft cap	Flange bolt	M6	8	8	0.8	5.8	
Timing chain damper 2	Bolt	M6	2	8	0.8	5.8	
Stopper guide	Panhead screw	M6	1	7	0.7	5.1	
Oil pump assembly	Panhead screw	M6	3	6	0.6	4.3	
Drain bolt (oil filter)	Bolt	M6	1	10	1.0	7.2	
Oil check bolt	Bolt	M6	1	7	0.7	5.1	
Plug (oil cooler)	Plug	M12	3	32	3.2	23	
Oil delivery pipe	Union bolt	M10	2	20	2.0	14	
Oil delivery pipe	Union bolt	M8	1	18	1.8	13	
Relief valve stay	Flange bolt	M6	1	10	1.0	7.2	
Carburetor joint (front)	Hose clamp	M4	1	2	0.2	1.4	
Carburetor joint (air filter assembly)	Hose clamp	M5	1	5	0.5	3.6	
Air filter case assembly	Bolt with washer	M6	3	5	0.5	3.6	
Exhaust pipe (cylinder head)	Nut	M8	2	7	0.7	5.1	
Exhaust pipe (muffler)	Flange bolt	M8	1	20	2.0	14	
Muffler	Bolt	M8	2	40	4.0	29	
Spark arrester	Bolt	M6	3	7	0.7	5.1	
Muffler purging bolt	Bolt	M8	1	20	2.0	14	
Muffler protector	Screw	M6	2	7	0.7	5.1	
Crankcase assembly	Bolt	M6	11	10	1.0	7.2	
Crankcase cover 1	Bolt	M6	8	10	1.0	7.2	
Crankcase cover 2 (starter motor cover)	Bolt	M6	5	10	1.0	7.2	
Crankcase cover 3	Bolt	M6	10	10	1.0	7.2	
One-way clutch	Bolt	M6	6	10	1.0	7.2	
Primary drive gear	Nut	M16	1	80	8.0	58	
Clutch boss	Nut	M16	1	75	7.5	54	
Pressure plate	Screw with washer	M6	5	8	0.8	5.8	

MAINTENANCE SPECIFICATIONS

SPEC



Part to be tightened	Part name	Thread size	Q'ty	Tightening torque			Remarks
				Nm	m·kg	ft·lb	
Push rod 2	Nut	M6	1	8	0.8	5.8	
Push lever	Screw	M8	1	12	1.2	8.7	
Clutch cable holder	Flange bolt	M6	2	10	1.0	7.2	
Drive sprocket	Nut	M18	1	110	11.0	80	
Lever stopper	Bolt	M6	1	10	1.0	7.2	
Shift pedal	Bolt	M6	1	10	1.0	7.2	
Starter motor	Flange bolt	M6	2	10	1.0	7.2	
Drain plug	Straight screw plug	M12	1	20	2.0	14	
Stator coil	Bolt	M5	3	7	0.7	5.1	



Tightening sequence

Cylinder head

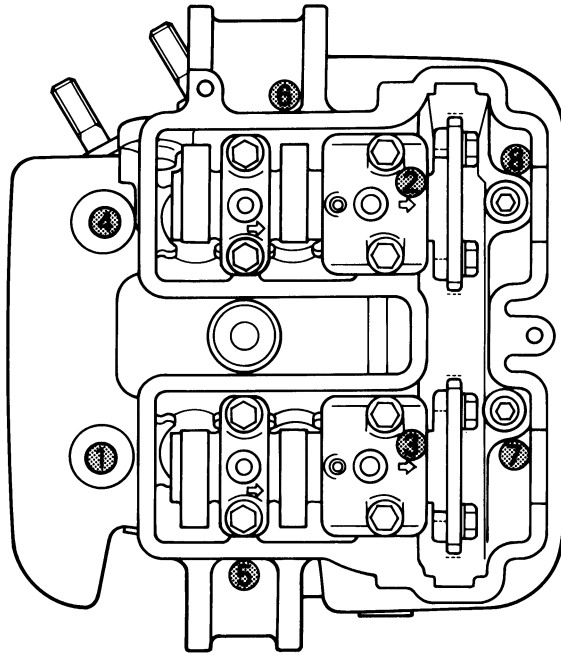

Lubrication chart

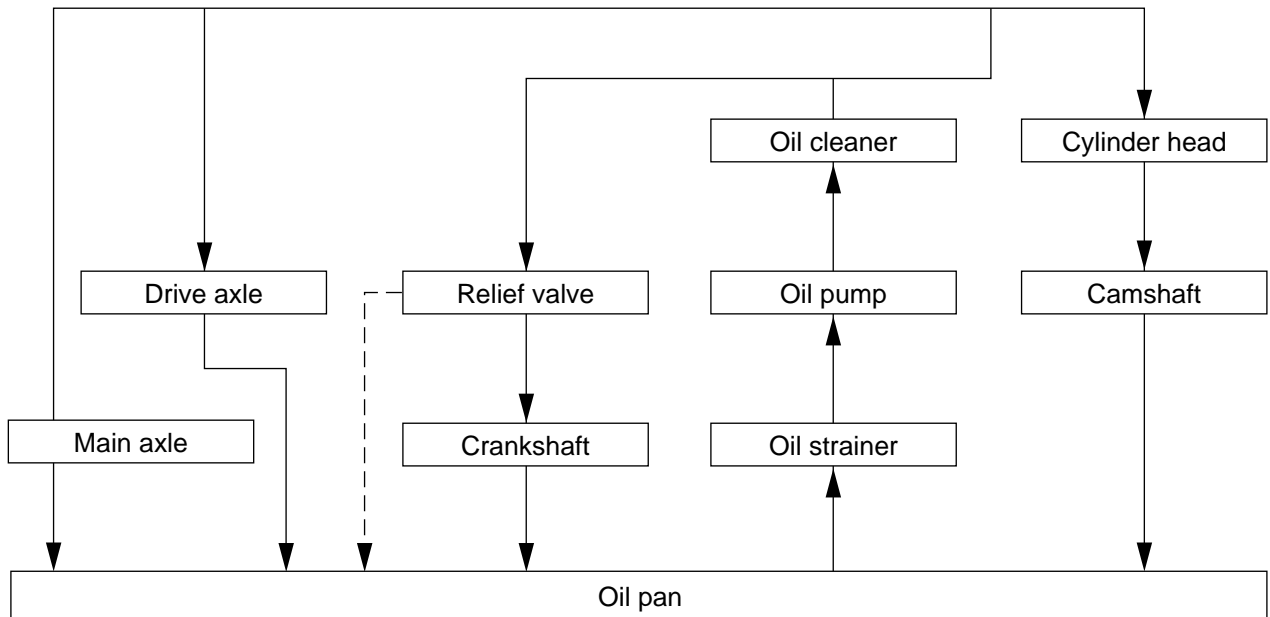



CHASSIS

Model	TTR250L(C)
Steering system: Steering bearing type	Taper roller bearing
Front suspension: Front fork travel Fork spring free length <Limit> Spring rate (K1) Stroke (K1) Optional spring Oil capacity Oil level Oil grade Enclosed gas / air pressure (STD) <Min. ~ max.> Inner tube outer diameter	280 mm (11.02 in) 472 mm (18.6 in) <462 mm (18.2 in)> 4 N/mm (0.41 kg/mm 22.8 lb/in) 0 ~ 280 mm (0.00 ~ 11.02 in) No 555 cm ³ (19.6 Imp oz, 18.8 US oz) 130 mm (5.12 in) Suspension oil "01" or equivalent 0 kPa (0 kg/cm ² , 0 psi) 0 ~ 40 kPa (0 ~ 0.4 kg/cm ² , 0~5.8 psi) 43 mm (1.69 in)
Rear suspension: Shock absorber travel Spring free length Fitting length Spring rate (K1) Stroke (K1) Optional spring Enclosed gas / air pressure (STD)	105 mm (4.13 in) 246 mm (9.69 in) 228 mm (8.98 in) 58.8 N/mm (6 kg/mm 335.8 lb/in) 0 ~ 105 mm (0.00 ~ 4.13 in) No 1,000 kPa (10 kg/cm ² , 145 psi)
Swingarm: <Free play limit> end side	<1 mm (0.04 in)> <1 mm (0.04 in)>
Front wheel: Type Rim size Rim material <Rim runout limit> radial lateral	Spoke wheel 1.60 × 21 Aluminum <2 mm (0.08 in)> <2 mm (0.08 in)>
Rear wheel: Type Rim size Rim material <Rim runout limit> radial lateral	Spoke wheel 2.15 × 18 Aluminum <2 mm (0.08 in)> <2 mm (0.08 in)>

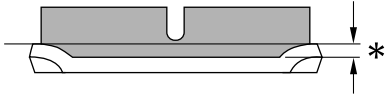
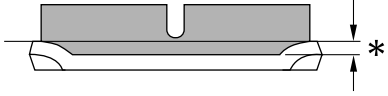

Model	TTR250L(C)
<p>Drive chain:</p> <p>Type / manufacturer</p> <p>No. of links</p> <p>Chain free play</p> <p>Sealed type chain</p>	<p>520V2 / DAIDO</p> <p>110</p> <p>35 ~ 50 mm (1.4 ~ 2.0 in)</p> <p>Yes</p>
<p>Front disc brake:</p> <p>Type</p> <p>Disc outside diameter × thickness</p> <p><Disc thickness limit></p> <p>Pad thickness inner</p> <p><Limit></p> <p>Pad thickness outer</p> <p><Limit></p>  <p>Master cylinder inside diameter</p> <p>Caliper cylinder inside diameter</p> <p>Brake fluid type</p>	<p>Single</p> <p>245.0 × 3.5 mm (9.65 × 0.14 in)</p> <p><3 mm (0.12 in)></p> <p>4.2 mm (0.17 in)</p> <p><1 mm (0.04 in)></p> <p>4.2 mm (0.17 in)</p> <p><1 mm (0.04 in)></p> <p>11 mm (0.43 in)</p> <p>27 mm (1.06 in)</p> <p>DOT #4</p>
<p>Rear disc brake:</p> <p>Type</p> <p>Disc outside diameter × thickness</p> <p><Disc thickness limit></p> <p>Pad thickness inner</p> <p><Limit></p> <p>Pad thickness outer</p> <p><Limit></p>  <p>Master cylinder inside diameter</p> <p>Caliper cylinder inside diameter</p> <p>Brake fluid type</p>	<p>Single</p> <p>220.0 × 4.5 mm (8.66 × 0.18 in)</p> <p><4 mm (0.16 in)></p> <p>5.6 mm (0.22 in)</p> <p><1 mm (0.04 in)></p> <p>5.6 mm (0.22 in)</p> <p><1 mm (0.04 in)></p> <p>12.7 mm (0.50 in)</p> <p>30.23 mm (1.19 in)</p> <p>DOT #4</p>
<p>Brake lever and brake pedal:</p> <p>Brake lever free play (at lever end)</p> <p>Brake pedal position</p> <p>Clutch lever free play (at lever end)</p>	<p>2 ~ 5 mm (0.08 ~ 0.20 in)</p> <p>10 mm (0.39 in)</p> <p>10 ~ 15 mm (0.39 ~ 0.59 in)</p>



TIGHTENING TORQUES

Part to be tightened	Thread size	Tightening torque			Remarks
		Nm	m.kg	ft.lb	
Engine (front upper) and engine stay	M10	64	6.4	46	Refer to NOTE.
Engine stay (front upper) and frame	M8	30	3.0	22	
Engine (front under) and frame	M10	64	6.4	46	
Engine (rear under) and frame	M10	64	6.4	46	
Engine (rear middle) and frame	M10	64	6.4	46	
Engine stay (rear middle) and frame	M8	23	2.3	17	
Engine (rear upper) and engine stay	M10	64	6.4	46	
Engine stay (rear upper) and frame	M8	30	3.0	22	
Engine guard and frame	M6	7	0.7	5.1	
Chain tensioner (upper) and frame	M8	19	1.9	13	
Chain tensioner (under) and frame	M6	10	1.0	7.2	
Main switch and frame	M6	7	0.7	5.1	
Back stay and frame	M8	35	3.5	25	
Pivot shaft and frame	M16	105	10.5	75	
Rear suspension (upper) and frame	M10	46	4.6	33	
Relay arm and frame	M10	46	4.6	33	
Relay arm and connecting rod	M14	59	5.9	43	
Relay arm and rear suspension	M10	40	4.0	29	
Connecting rod and swingarm	M12	59	5.9	43	
Chain protector and chain	M6	4	0.4	2.9	
Chain guide and swingarm	M6	7	0.7	5.1	
Chain protector and swingarm	M6	7	0.7	5.1	
Chain case and swingarm	M6	7	0.7	5.1	
Rear brake hose (front) and swingarm	M6	7	0.7	5.1	
Rear brake hose (rear) and swingarm	M5	4	0.4	2.9	
Swingarm and end 3	M5	4	0.4	2.9	
Swingarm and bracket	M5	4	0.4	2.9	
Handle crown and inner tube	M8	23	2.3	17	
Handle crown and steering shaft	M24	120	12.0	85	
Steering shaft and ring nut	M28	5	0.5	3.6	
Handle under holder and handle crown	M12	40	4.0	29	
Front master cylinder cap	M4	2	0.2	1.4	
Front master cylinder and handlebar	M6	7	0.7	5.1	
Front fender and front fork	M6	7	0.7	5.1	
Speedometer and handle crown	M6	7	0.7	5.1	
Headlight and headlight stay	M6	7	0.7	5.1	
Headlight under stay and under bracket	M6	7	0.7	5.1	
Base valve and outer tube	M22	55	5.5	40	
Cap nut and inner tube	M40	28	2.8	20	
Fuel tank bracket and frame	M6	10	1.0	7.2	
Fuel tank and fuel cock	M6	7	0.7	5.1	
Rectifier/regulator and frame	M6	7	0.7	5.1	





Part to be tightened	Thread size	Tightening torque			Remarks
		Nm	m·kg	ft·lb	
Ignition coil and frame	M6	7	0.7	5.1	
Battery box and frame	M6	7	0.7	5.1	
Side cover and frame	M6	7	0.7	5.1	
Seat and frame	M6	7	0.7	5.1	
Rear fender and frame	M6	7	0.7	5.1	
Helmet holder and frame	M6	7	0.7	5.1	
Taillight and rear fender	M6	6	0.6	4.3	
Front hub and front disk	M6	12	1.2	8.7	
Front wheel shaft and front fork	M14	58	5.8	42	
Axle holder and front fork	M6	10	1.0	7.2	
Front brake caliper and front fork	M10	30	3.0	22	
Union bolt (front)	M10	30	3.0	22	
Rear wheel shaft and nut	M18	105	10.5	75	
Rear hub and sprocket	M8	35	3.5	25	
Rear hub and rear disk	M6	12	1.2	8.7	
Union bolt (rear)	M10	30	3.0	22	
Rear caliper and protector	M6	7	0.7	5.1	
Sidestand and nut	M10	64	6.4	46	
Rear footrest and frame	M8	23	2.3	17	
Rear master cylinder and frame	M8	23	2.3	17	
Rear reservoir tank and frame	M6	7	0.7	5.1	
Rear brake pedal and frame	M8	19	1.9	13	
Footrest bracket and frame	M10	64	6.4	46	

NOTE:

1. First tighten the ring nut approximately 38 Nm (3.8 m · kg, 27 ft · lb) by using the torque wrench, then loosen the ring nut one turn.
2. Retighten the ring nut to specification.



ELECTRICAL

Model	TTR250L(C)
Voltage:	12 V
Ignition system: Ignition timing (B.T.D.C.) Advanced timing (B.T.D.C.) Advancer type	10° at 1,300 r/min 31° at 8,500 r/min Digital type
C.D.I.: Pickup coil resistance / color C.D.I. unit model / manufacturer	190 ~ 230 Ω at 20 °C (68 °F) / Yellow – Blue F8T31871 / MITSUBISHI
Ignition coil: Model / manufacturer Primary winding resistance Secondary winding resistance	F6T535 / MITSUBISHI 0.36 ~ 0.48 Ω at 20 °C (68 °F) 5.44 ~ 7.36 kΩ at 20 °C (68 °F)
Spark plug cap: Type Resistance	Resin type 10 kΩ
Charging system: Type Model / manufacturer Standard output Stator coil resistance / color	A.C. magneto generator F4T250 / MITSUBISHI 14 V 13.5 A at 5,000 r/min 1.0 ~ 1.2 Ω at 20 °C (68 °F) / White – White
Rectifier regulator: Type Model / manufacturer No load regulated voltage (DC) Capacity Withstand voltage	Semi-conductor, short-circuit type SH629A-12 / SHINDENGEN 14.1 ~ 14.9 V 10 A 200 V
Battery: Manufacturer Specific gravity	GS 1.320
Electric starter system: Type Starter motor Model / manufacturer Output Armature coil resistance Brush overall length <Limit> Brush spring pressure Commutator diameter <Wear limit> Mica undercut	Constant mesh type SM-13 / MITSUBA 0.65 kW 0.0017 ~ 0.0027 Ω 10 mm (0.39 in) <4 mm (0.16 in)> 8.82 N (889 gf, 31.75 oz) 28 mm (1.10 in) <27 mm (1.06 in)> 0.7 mm (0.03 in)

MAINTENANCE SPECIFICATIONS

SPEC



Model	TTR250L(C)
Starter relay: Model / manufacturer Amperage rating Coil winding resistance	MS5D-361 / JIDECO 100 A 3.9 ~ 4.7 Ω at 20 °C (68 °F)



GENERAL TORQUE SPECIFICATIONS

This chart specifies torque for standard fasteners with standard I.S.O. pitch threads. Torque specifications for special components or assemblies are included in the applicable sections of this book. To avoid warpage, tighten multi-fastener assemblies in a crisscross fashion, in progressive stages, until full torque is reached. Unless otherwise specified, torque specifications call for clean, dry threads. Components should be at room temperature.

A (Nut)	B (Bolt)	General torque specifications		
		Nm	m • kg	ft • lb
10 mm	6 mm	6	0.6	4.3
12 mm	8 mm	15	1.5	11
14 mm	10 mm	30	3.0	22
17 mm	12 mm	55	5.5	40
19 mm	14 mm	85	8.5	61
22 mm	16 mm	130	13.0	94

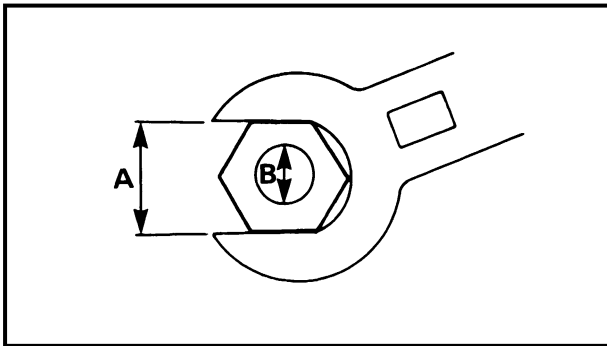

A: Distance across flats
B: Outside thread diameter



LUBRICATION POINTS AND LUBRICANT TYPES
ENGINE

Lubrication Point	Lubricant Type
Oil seal lips	
O-ring	
Bearing	
Piston surface	
Piston pin	
Crankshaft journal	
Balancer (bearing / shaft / gear)	
Buffer boss	
Camshaft cam lobe / journal	
Valve stem (IN, EX)	
Valve stem end (IN, EX)	
Valve lifter (IN, EX)	
Oil pump rotor (inner / outer) shaft	
Oil pump gasket	
Push lever assembly	
Idle gear (1, 2) surface	
Push rod assembly	
Primary driven gear	
Transmission gear (wheel / pinion)	
Axle (main / drive)	
Shift cam	
Shift fork / guide bar	
Shift shaft (1, 2)	
Matching surface (cylinder head and cylinder head cover)	Yamaha Bond No. 1215®
Crankcase matching surface	Yamaha Bond No. 1215®



CHASSIS

Lubrication Point	Lubricant Type
Front wheel oil seal lips	
Rear wheel oil seal lips	
Bearing, oil seal lips (connecting rod)	
Oil seal lips, bearings (relay arm and frame)	
Pivot shaft (swingarm)	
Bearing (relay arm and rear shock absorber)	
Bolts, collars, seal lips (relay arm and frame)	
Bolt, collars (relay arm and connecting rod)	
Bolt (connecting rod and swingarm)	
Brake pedal shaft	
Bearings (steering head pipe)	
Tube guide (throttle grip) inner surface	
Brake lever, sliding surface	
Clutch lever, sliding surface	
Clutch cable end	
Sidestand bolt, sliding surface	
Bush (chain tensioner)	



LUBRICATION DIAGRAM

- ① Oil pump
- ② Push lever
- ③ Delivery pipe

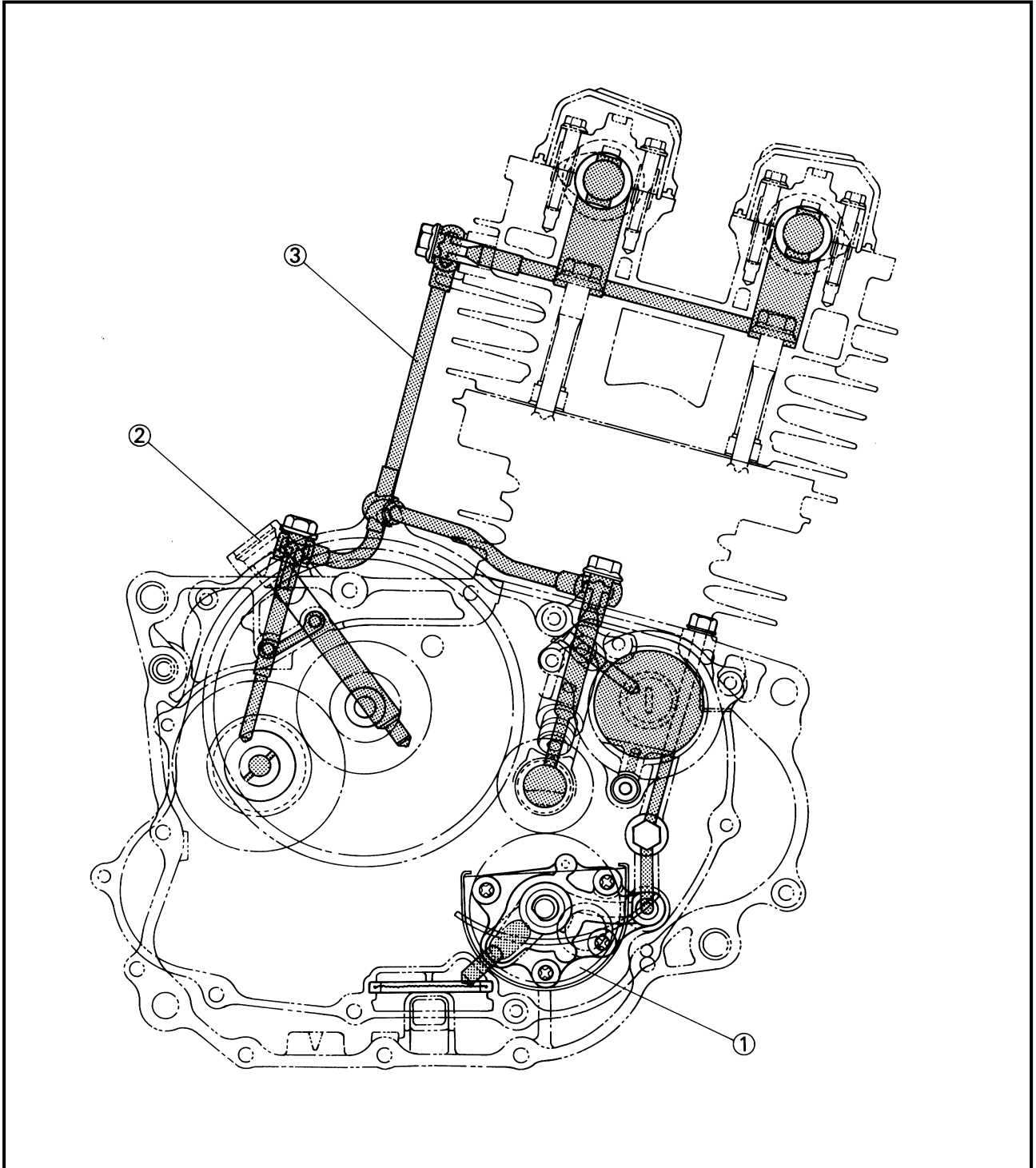



- ① Relief valve
- ② Crankshaft
- ③ Main axle
- ④ Drive axle
- ⑤ Delivery pipe
- ⑥ Push lever
- ⑦ Camshaft

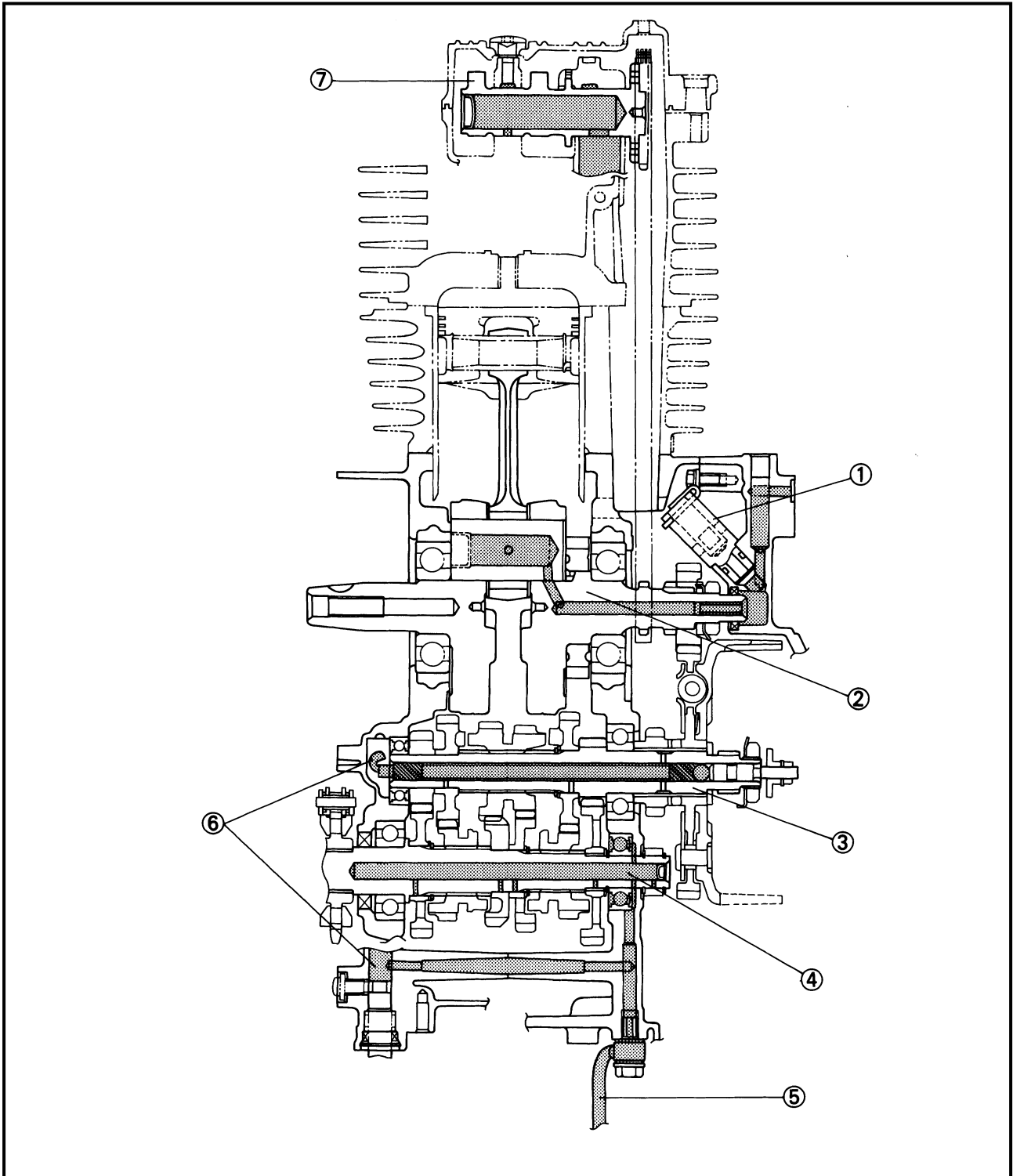



- ① Oil cleaner
- ② Check bolt
- ③ Oil pump
- ④ Oil strainer

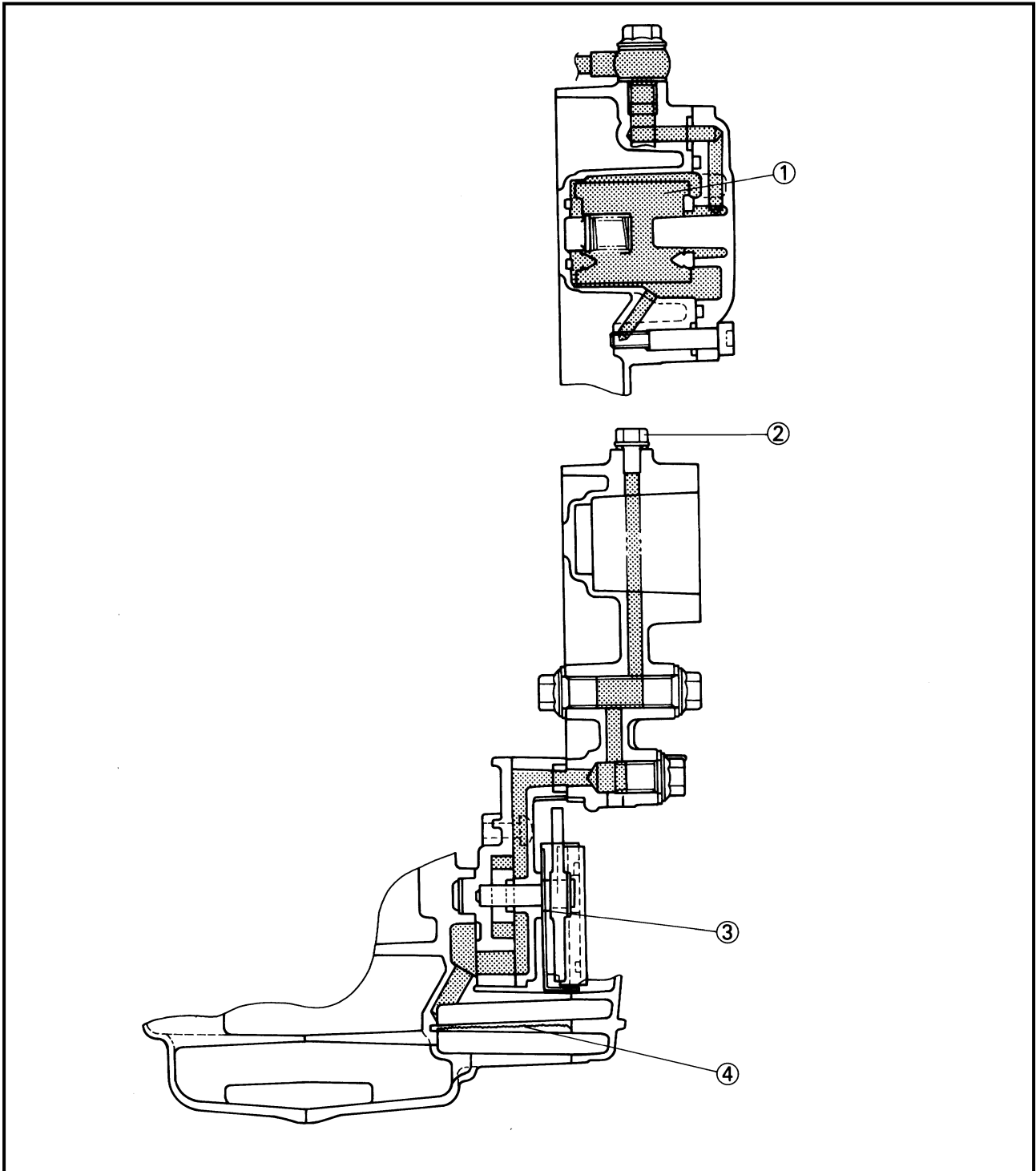



CABLE ROUTING

- ① Throttle cable
- ② Wire sub lead
- ③ A.C. magneto lead
- ④ Front brake hose
- ⑤ Handlebar switch lead (right)
- ⑥ Clutch switch lead
- ⑦ Handlebar switch lead (left)
- ⑧ Headlight lead
- ⑨ Wireharness
- ⑩ Clutch cable
- ⑪ Air vent hose (right)
- ⑫ Drain hose
- ⑬ Breather hose
- ⑭ Air vent hose (left)

- A Cut the end of the band after tightening.
- B Do not put this portion of the harness on the frame after connection.
- C Install the clamp with its open side facing forward.
- D Install the band, making sure its end faces backward.
- E Clamp the front brake hose between its white mark and the slot.
- F Put the handlebar switch (left) lead on top of the leads.
- G Pass the spark plug lead over the leads.
- H Install the clamp with its end facing downward.
- I Pass the breather hose on the inside of the leads that run side by side, but do not clamp it with a band or other clamping device.

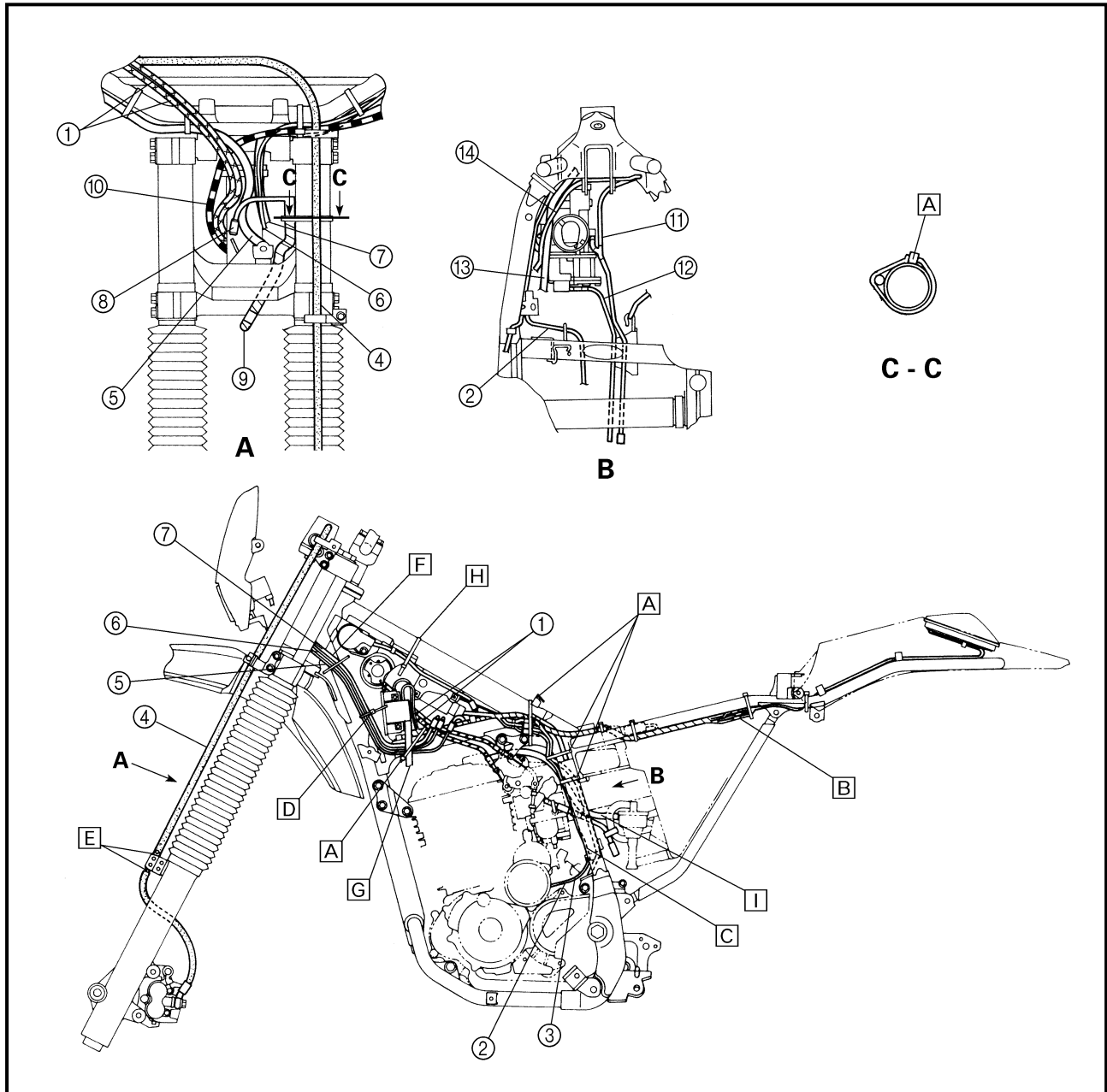



- | | |
|----------------------------|--|
| ① Rectifier/regulator lead | [A] Install the clamp with its open side facing outward. |
| ② Main switch lead | [B] Tighten the main switch lead to the rectifier/regulator. |
| ③ Ignition coil lead | [C] Tighten the ignition coil lead to the ignition coil. |
| ④ Throttle cable | [D] Pass the throttle cable 1 over the throttle cable 2. |
| ⑤ Clutch cable | [E] Install the clamp with its open side facing upward. |
| ⑥ Wireharness | [F] Fasten the clutch cable at the white tape marker with a clamp. |
| ⑦ Battery (-) lead | [G] Pass the fuel tank breather hose under the handle tension bar. |
| ⑧ Battery (+) lead | [H] Affix the fuel tank breather hose and speedometer cable to the clamp. |
| ⑨ Starter relay lead | [I] Pass the fuel tank breather hose and speedometer cable through the wire guide. |
| ⑩ Fuse (main) lead | [J] Fasten the speedometer cable at the white tape marker with a clamp. |
| ⑪ Fuel tank breather hose | |

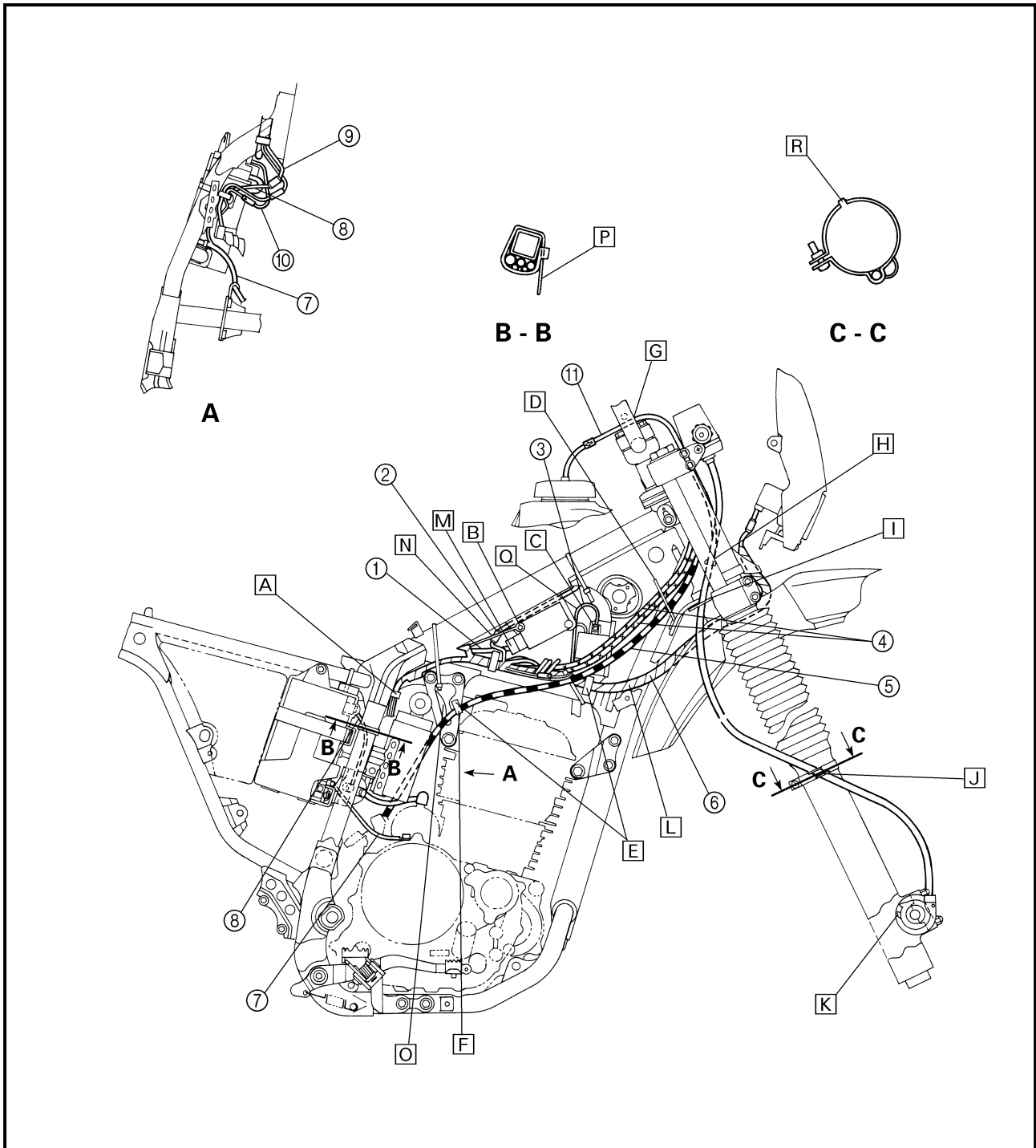



- K** Make sure the projection on the front fork is placed in the slot in the speedometer gear unit.
- L** Pass the wireharness over the fuel tank bracket.
- M** Pass the wireharness under the regulator lead coupler. Make sure the coupler does not go over the right side.
- N** Insert the coupler on the inside of the ground lead.
- O** Pass the clamp through the right engine stay.
- P** Face the band end to the inside of the vehicle.
- Q** Pass the ignition coil lead on the inside of the throttle cable.
- R** Align the slot and the projection on the front fork.

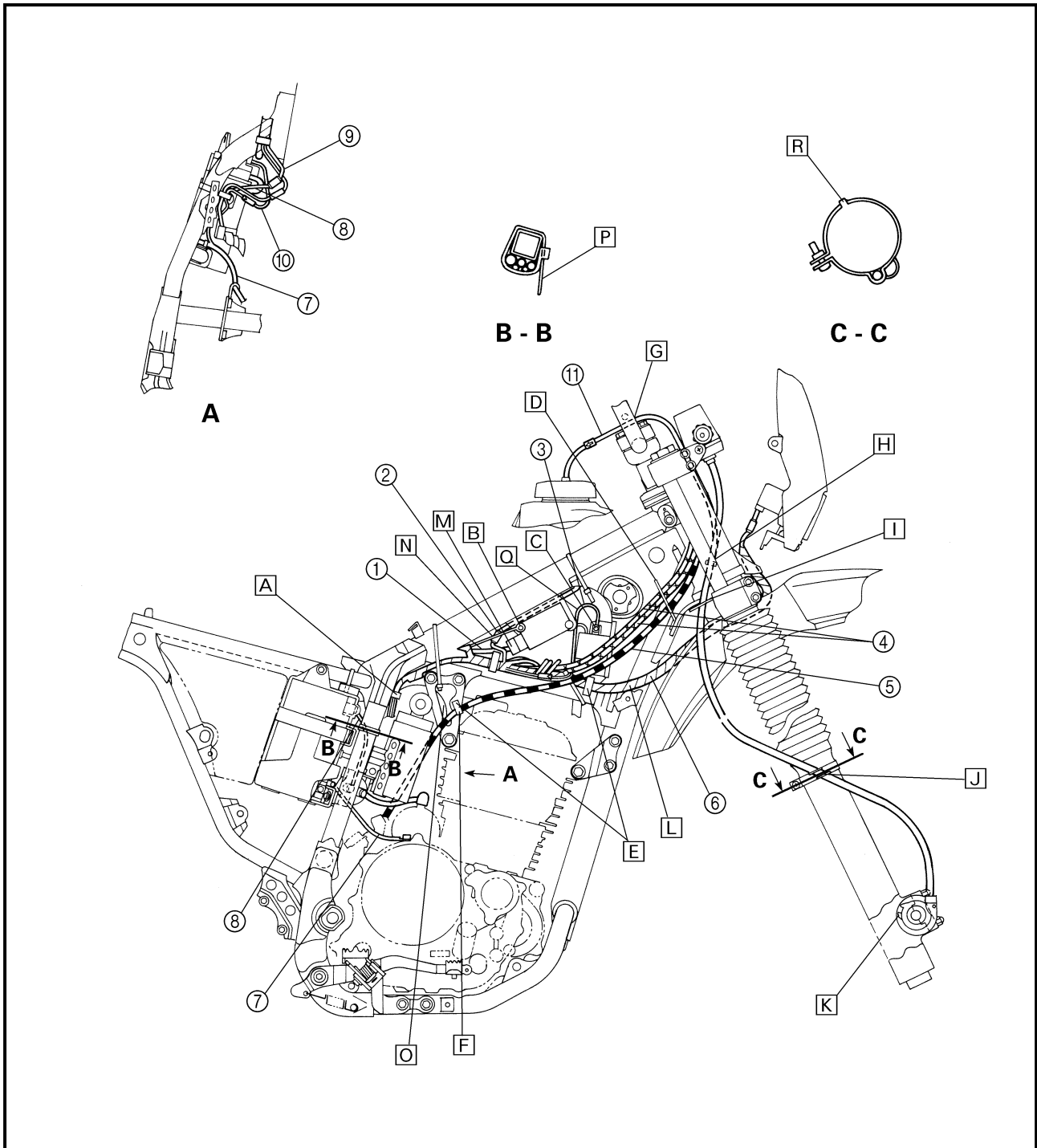



- ① Clutch switch lead
- ② Clutch cable
- ③ Handlebar switch (left) lead
- ④ Handlebar switch (right) lead
- ⑤ Front brake hose
- ⑥ Throttle cable
- ⑦ Taillight lead

- A The pipe portion of the brake hose should touch the projection on the master cylinder.
- B Install the brake hose with its white mark facing forward.
- C Pass the throttle cable 1 to the inside of the throttle cable 2.
- D Pass the handlebar switch (right) lead to the front of the clutch cable.
- E Do not allow the air ventilation hose to go over the frame.
- F Pass the air ventilation hose through the guide near the air filter intake.
- G Install the clamp with its open side facing inward.
- H Pass the lead under the frame.
- I Fasten the wireharness to the guide on the frame with a plastic band.
- J Pass the wireharness through the guide.

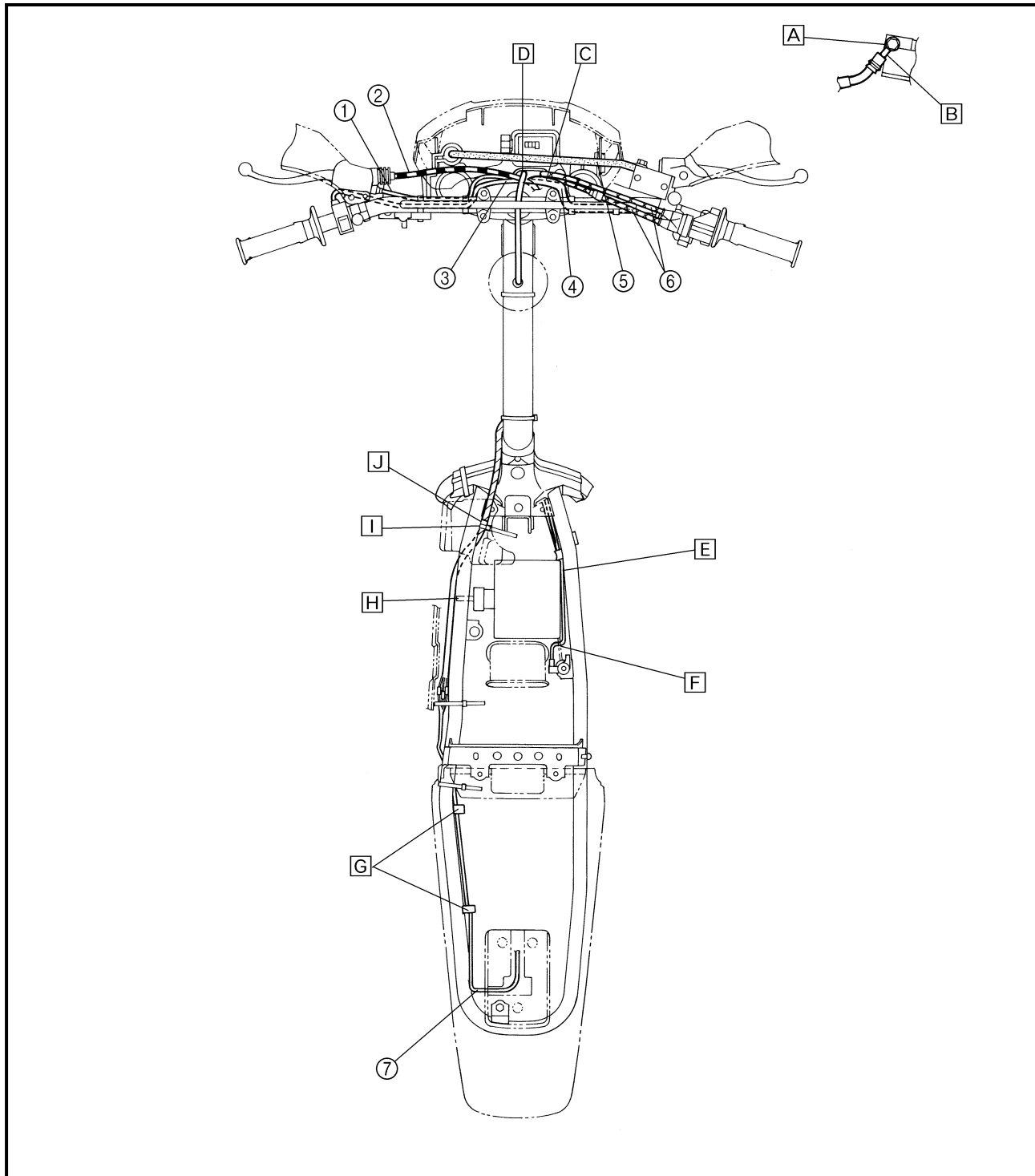

PERIODIC INSPECTION AND ADJUSTMENT

INTRODUCTION

This chapter includes all information necessary to perform recommended inspections and adjustments. These preventive maintenance procedures, if followed, will ensure more reliable vehicle operation and a longer service life. The need for costly overhaul work will be greatly reduced. This information applies to vehicles already in service as well as new vehicles that are being prepared for sale. All service technicians should be familiar with this entire chapter.

PERIODIC MAINTENANCE/LUBRICATION

	No.	ITEM	CHECKS AND MAINTENANCE JOBS	INITIAL	EVERY	
				100 mi (150 km) or 1 month	600 mi (1,000 km) or 6 months	1,200 mi (2,000 km) or 12 months
Emission Items	1	* Fuel line	<ul style="list-style-type: none"> • Check fuel hoses for cracks or damage. • Replace if necessary. 		√	√
	2	Spark plug	<ul style="list-style-type: none"> • Check condition. • Clean, regap or replace if necessary. 		√	√
	3	* Valves	<ul style="list-style-type: none"> • Check valve clearance. • Adjust if necessary. 			√
	4	Air filter	<ul style="list-style-type: none"> • Clean or replace if necessary. 		√	√
	5	* Crankcase breath- er system	<ul style="list-style-type: none"> • Check ventilation hose for cracks or damage and drain any deposit. • Replace if necessary. 		√	√
	6	* Carburetor	<ul style="list-style-type: none"> • Check engine idling speed and starter operation. • Adjust if necessary. 	√	√	√
	7	Exhaust system	<ul style="list-style-type: none"> • Check for leakage. • Retighten if necessary. • Replace gasket if necessary. 		√	√
	8	Engine oil	<ul style="list-style-type: none"> • Check oil level and vehicle for oil leakage. • Correct if necessary. • Change. (Warm engine before draining.) 	√	√	√
	9	Engine oil filter el- ement	<ul style="list-style-type: none"> • Clean. 	√	√	√
General Items	10	Clutch	<ul style="list-style-type: none"> • Check operation. • Adjust or replace cable. 	√	√	√
	11	* Front brake	<ul style="list-style-type: none"> • Check operation, fluid level and vehicle for fluid leakage. • Correct accordingly. • Replace brake pads if necessary. 	√	√	√
General Items	12	* Rear brake	<ul style="list-style-type: none"> • Check operation, fluid level and vehicle for fluid leakage. • Correct accordingly. • Replace brake pads if necessary. 	√	√	√
	13	* Wheels	<ul style="list-style-type: none"> • Check balance, runout, spoke tightness and for damage. • Tighten spokes and rebalance, replace if necessary. 	√	√	√
	14	* Tires	<ul style="list-style-type: none"> • Check tread depth and for damage. • Replace if necessary. • Check air pressure. • Correct if necessary. 		√	√
	15	* Wheel bearings	<ul style="list-style-type: none"> • Check bearing looseness or damage. • Replace if necessary. 		√	√

PERIODIC MAINTENANCE/LUBRICATION



	No.	ITEM	CHECKS AND MAINTENANCE JOBS	INITIAL	EVERY	
				100 mi (150 km) or 1 month	600 mi (1,000 km) or 6 months	1,200 mi (2,000 km) or 12 months
General Items	16	Drive chain	<ul style="list-style-type: none"> • Check chain slack. • Adjust if necessary. Make sure that the rear wheel is properly aligned. • Clean and lubricate. 	Every ride		
	17	* Steering bearings	<ul style="list-style-type: none"> • Check bearing play and steering for roughness. • Correct accordingly. • Lubricate with lithium soap base grease every 1,200 mi (2,000 km) or 12 months (whichever comes first). 	√		√
	18	* Chassis fasteners	<ul style="list-style-type: none"> • Make sure that all nuts, bolts and screws are properly tightened. • Tighten if necessary. 	√	√	√
	19	Sidestand	<ul style="list-style-type: none"> • Check operation. • Lubricate and repair if necessary. 	√		√
	20	* Spark arrester	<ul style="list-style-type: none"> • Clean. 			√
	21	* Front fork	<ul style="list-style-type: none"> • Check operation and for oil leakage. • Correct accordingly. 		√	√
	22	* Rear shock absorber assembly	<ul style="list-style-type: none"> • Check operation and shock absorber for oil leakage. • Replace shock absorber assembly if necessary. 		√	√
	23	* Rear shock absorber pivoting point	<ul style="list-style-type: none"> • Check operation. • Lubricate with molybdenum disulfide grease. 			√

* : Since these items require special tools, data and technical skills, they should be serviced by a Yamaha dealer.

NOTE:

- The air filter needs more frequent service if you are riding in unusually wet or dusty areas.
- Hydraulic brake system
 - When disassembling the master cylinder or caliper cylinder, always replace the brake fluid. Check the brake fluid level regularly and fill as required.
 - Replace the oil seals on the inner parts of the master cylinder and caliper cylinder every two years.
 - Replace the brake hoses every four years, or if cracked or damaged.

3

**SEAT, FUEL TANK AND COVERS
REMOVAL**

⚠ WARNING

Securely support the motorcycle so there is no danger of it falling over.

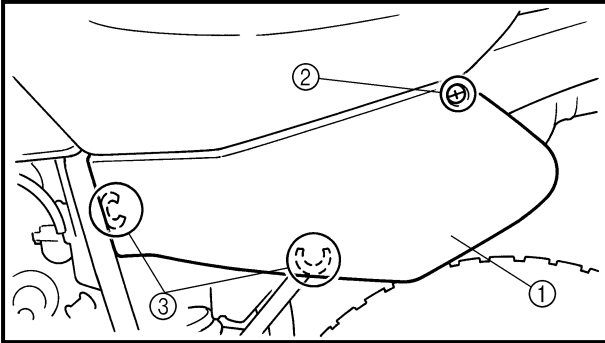

- 1.Remove:
● Side cover (left) ①

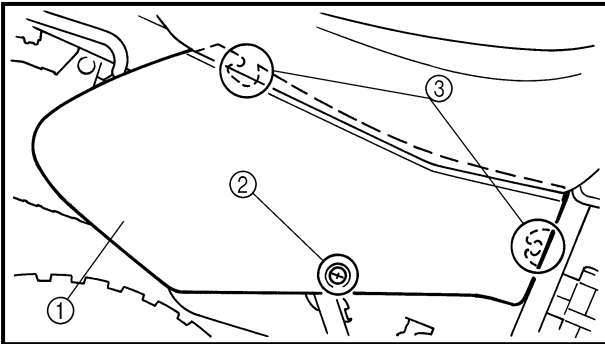

- 2.Remove:
● Side cover (right) ①

NOTE: _____
When removing the side covers (left and right), remove the bolt ②. Then pull the front and rear portion of the side cover outward to remove the projection ③ from the grommet.

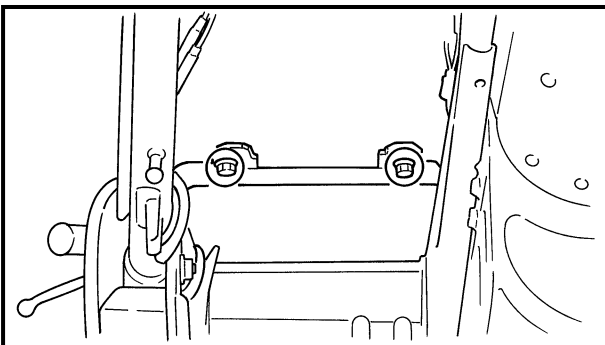

- 3.Remove:
● Seat

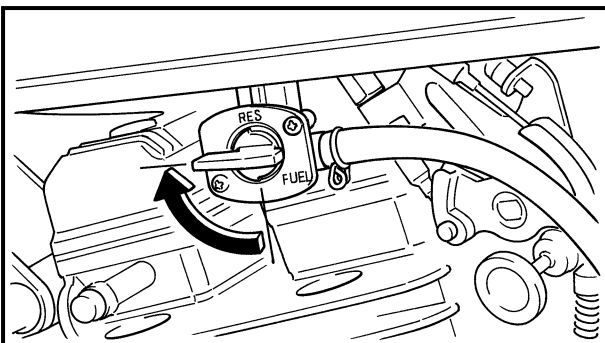

- 4.Turn the fuel cock to "OFF".

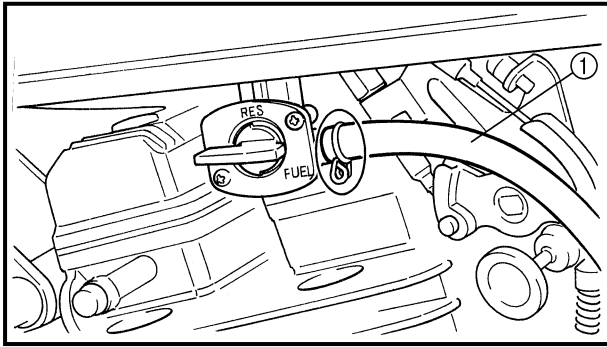

5. Disconnect:

- Fuel hose ①

NOTE:

Place a rag on the engine to absorb any spill fuel.

⚠ WARNING

Gasoline is highly flammable.

Avoid spilling fuel on the hot engine.

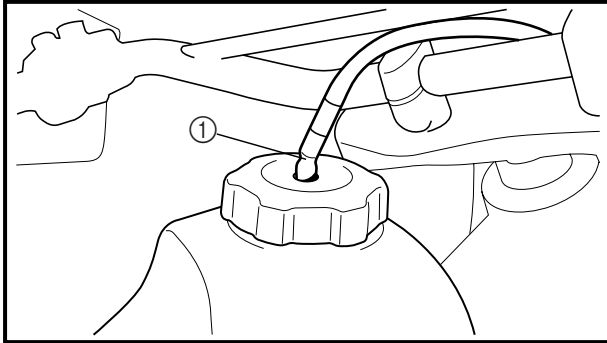

6. Disconnect:

- Fuel tank breather hose ①

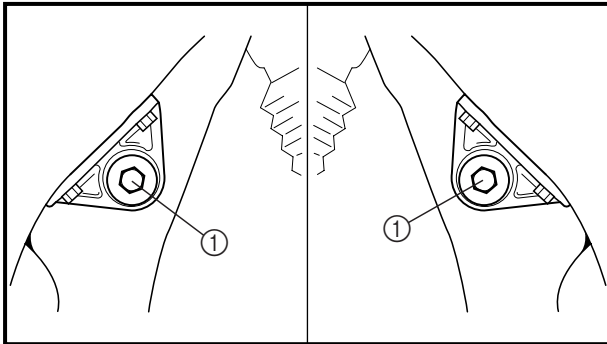

7. Remove:

- Fuel tank bracket bolts ①

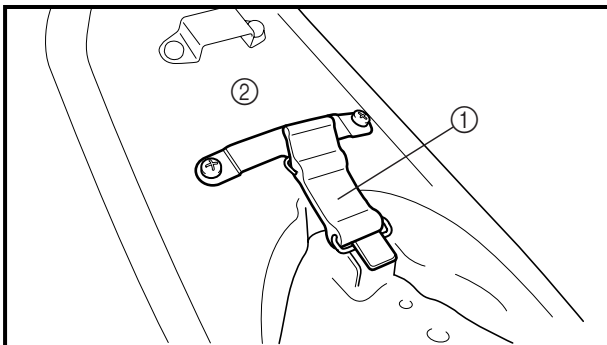

8. Remove:

- Band ①
- Fuel tank ②

INSTALLATION

Reverse the "REMOVAL" procedure. Note the following points.

1. Install:

- Fuel tank



Bolts (fuel tank bracket):
10 Nm (1.0 m • kg, 7.2 ft • lb)

SEAT, FUEL TANK AND COVERS

CHK
ADJ

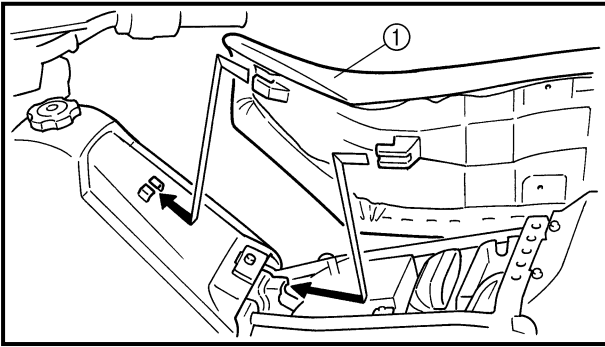

2.Install:

- Seat ①
- Side covers (left and right)



Bolt (seat):

7 Nm (0.7 m • kg, 5.1 ft • lb)

Bolt (side cover):

7 Nm (0.7 m • kg, 5.1 ft • lb)

ENGINE VALVE CLEARANCE ADJUSTMENT

- NOTE:** _____
- The valve clearance must be adjusted when the engine is cool to the touch.
 - Adjust the valve clearance when the piston is at the Top Dead Center (T.D.C.) on compression stroke.

⚠ WARNING _____

Securely support the motorcycle so there is no danger of it falling over.

- 1.Remove:
- Side covers
 - Seat
 - Fuel tank
- Refer to "SEAT, FUEL TANK AND COVERS".

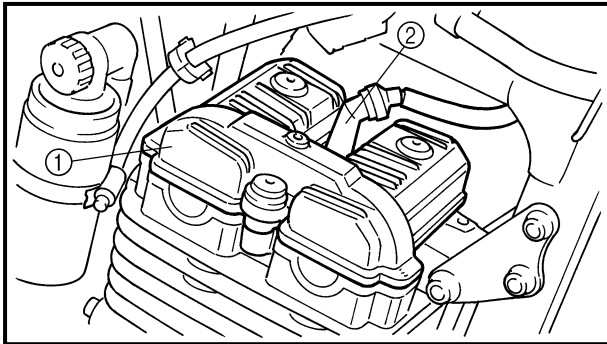

- 2.Remove:
- Cylinder head cover ①
 - Spark plug ②

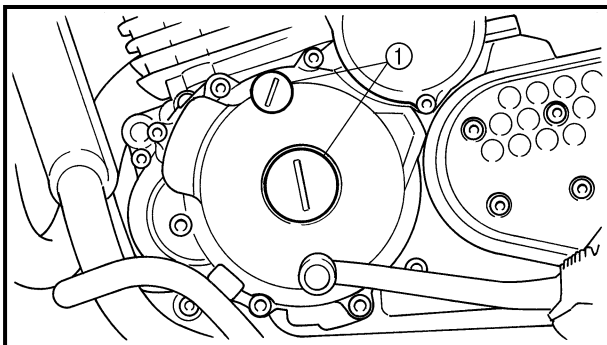

- 3.Remove:
- Plugs ① (with O-ring)

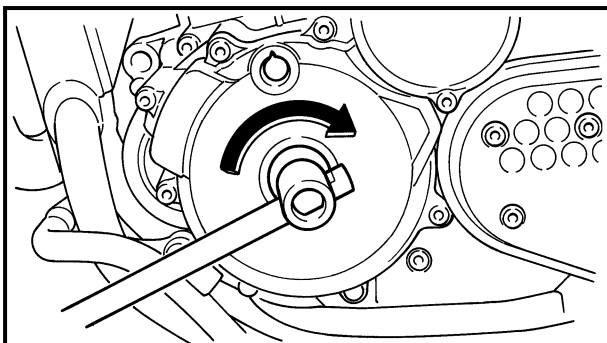

- 4.Align:
- "T" mark on the rotor
- With the stationary pointer on the crankcase cover.

- T.D.C. alignment steps:**
- Turn the crankshaft clockwise with a wrench.

VALVE CLEARANCE ADJUSTMENT

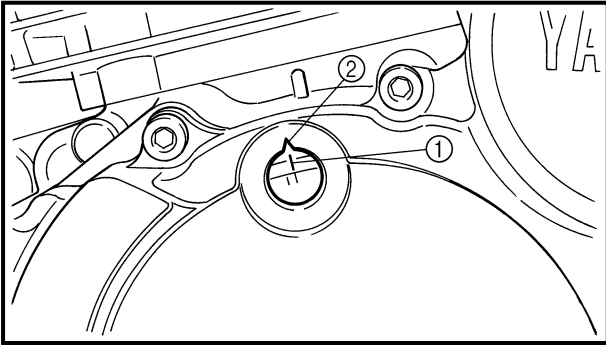

- Align the “T” mark ① on the rotor with stationary pointer ② on the crankcase cover. When the “T” mark is aligned with the stationary pointer, the piston is at Top Dead Center (T.D.C.).

NOTE: _____

T.D.C. on compression stroke check:

- Both cam lobes must have a valve clearance when the rotor match mark ① is aligned with the stationary pointer match mark ②.
- If not, give the crankshaft one counter-clockwise turn to meet above condition.

5.Check:

- Valve clearance
Measure the valve clearance using a feeler gauge.
Out of specification → Adjust.



Valve clearance (cold):

Intake:
0.09 ~ 0.19 mm
(0.004 ~ 0.007 in)
Exhaust:
0.19 ~ 0.27 mm
(0.007 ~ 0.011 in)

Checking steps:

NOTE: _____

TDC on compression stroke can be found when the cam lobes are opposite each other as shown.

- Measure the valve clearance using a feeler gauge ①.

NOTE: _____

Record the measured reading if the clearance is incorrect.

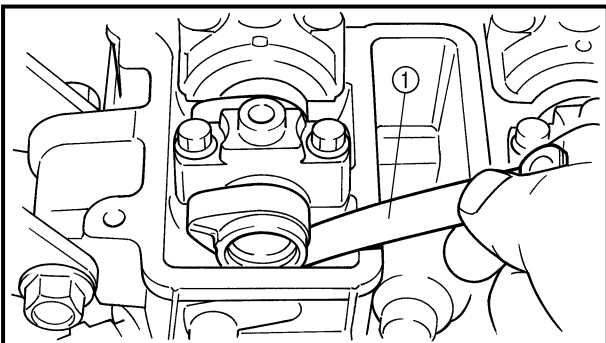
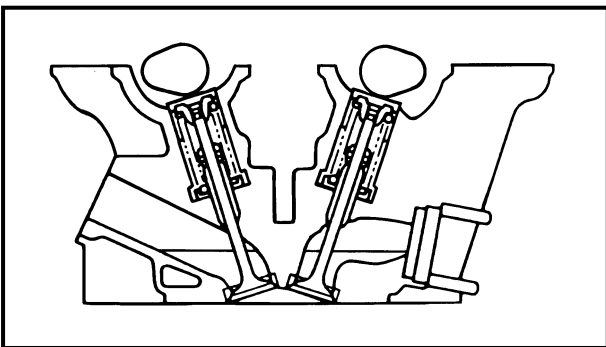

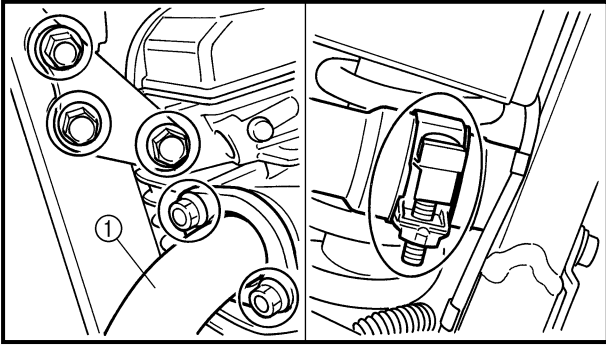

- 6.Remove:
- Exhaust pipe ①

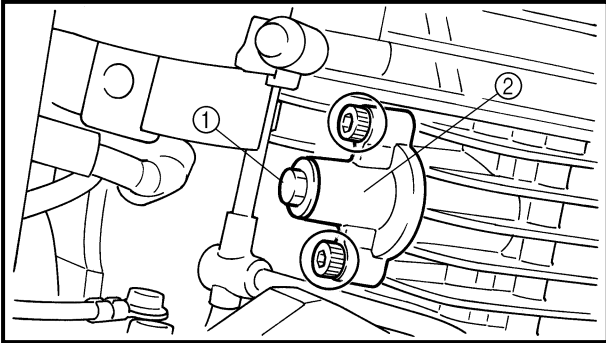

- 7.Loosen:
- Cap bolt ①
- 8.Remove:
- Cam chain tensioner ②

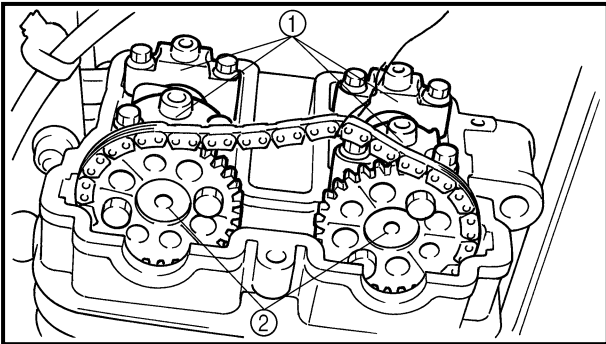

- 9.Remove:
- Camshaft caps ①
 - Camshafts ②

NOTE: _____

- Refer to "ENGINE DISASSEMBLY-CYLINDER HEAD, CAMSHAFTS, CYLINDER AND PISTON" in CHAPTER 4.
- Fasten a wire to the cam chain to prevent it from falling into the crankcase.

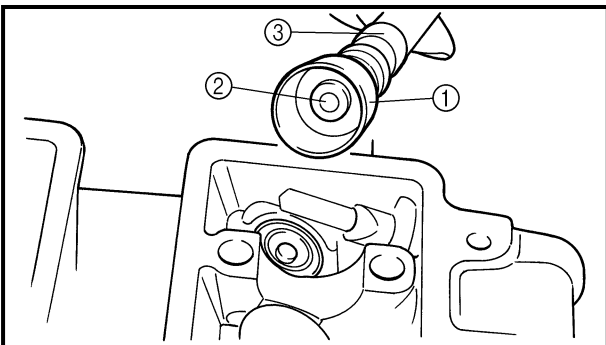

- 10.Adjust:
- Valve clearance

Adjustment steps:

- Remove the valve lifter ① and pad ② using the valve lapper ③.

NOTE: _____

- Place a piece of rag in the cam chain room to prevent the pad from falling into the crankcase.
- Remove the rag after adjustment.

- Select the proper valve adjusting pad from the following chart.

VALVE CLEARANCE ADJUSTMENT



INTAKE

B MEASURED CLEARANCE	A INSTALLED PAD NUMBER																											
	120	125	130	135	140	145	150	155	160	165	170	175	180	185	190	195	200	205	210	215	220	225	230	235	240			
0.00 ~ 0.04					120	125	130	135	140	145	150	155	160	165	170	175	180	185	190	195	200	205	210	215	220	225		
0.05 ~ 0.08			120	125	130	135	140	145	150	155	160	165	170	175	180	185	190	195	200	205	210	215	220	225	230			
0.09 ~ 0.17	RECOMMENDED CLEARANCE																											
0.18 ~ 0.20	120	125	130	135	140	145	150	155	160	165	170	175	180	185	190	195	200	205	210	215	220	225	230	235	240			
0.21 ~ 0.25	125	130	135	140	145	150	155	160	165	170	175	180	185	190	195	200	205	210	215	220	225	230	235	240				
0.26 ~ 0.30	130	135	140	145	150	155	160	165	170	175	180	185	190	195	200	205	210	215	220	225	230	235	240					
0.31 ~ 0.35	135	140	145	150	155	160	165	170	175	180	185	190	195	200	205	210	215	220	225	230	235	240						
0.36 ~ 0.40	140	145	150	155	160	165	170	175	180	185	190	195	200	205	210	215	220	225	230	235	240							
0.41 ~ 0.45	145	150	155	160	165	170	175	180	185	190	195	200	205	210	215	220	225	230	235	240								
0.46 ~ 0.50	150	155	160	165	170	175	180	185	190	195	200	205	210	215	220	225	230	235	240									
0.51 ~ 0.55	155	160	165	170	175	180	185	190	195	200	205	210	215	220	225	230	235	240										
0.56 ~ 0.60	160	165	170	175	180	185	190	195	200	205	210	215	220	225	230	235	240											
0.61 ~ 0.65	165	170	175	180	185	190	195	200	205	210	215	220	225	230	235	240												
0.66 ~ 0.70	170	175	180	185	190	195	200	205	210	215	220	225	230	235	240													
0.71 ~ 0.75	175	180	185	190	195	200	205	210	215	220	225	230	235	240														
0.76 ~ 0.80	180	185	190	195	200	205	210	215	220	225	230	235	240															
0.81 ~ 0.85	185	190	195	200	205	210	215	220	225	230	235	240																
0.86 ~ 0.90	190	195	200	205	210	215	220	225	230	235	240																	
0.91 ~ 0.95	195	200	205	210	215	220	225	230	235	240																		
0.96 ~ 1.00	200	205	210	215	220	225	230	235	240																			
1.01 ~ 1.05	205	210	215	220	225	230	235	240																				
1.06 ~ 1.10	210	215	220	225	230	235	240																					
1.11 ~ 1.15	215	220	225	230	235	240																						
1.16 ~ 1.20	220	225	230	235	240																							
1.21 ~ 1.25	225	230	235	240																								
1.26 ~ 1.30	230	235	240																									
1.31 ~ 1.35	235	240																										
1.36 ~ 1.40	240																											

VALVE CLEARANCE (cold):
 0.09 ~ 0.17 mm (0.004 ~ 0.007 in)
Example: Installed is: 170
 Measured clearance is:
 0.27 mm (0.011 in)
 Replace 170 pad with 180 pad

EXHAUST

B MEASURED CLEARANCE	A INSTALLED PAD NUMBER																											
	120	125	130	135	140	145	150	155	160	165	170	175	180	185	190	195	200	205	210	215	220	225	230	235	240			
0.00 ~ 0.04						120	125	130	135	140	145	150	155	160	165	170	175	180	185	190	195	200	205	210	215			
0.05 ~ 0.09					120	125	130	135	140	145	150	155	160	165	170	175	180	185	190	195	200	205	210	215	220			
0.10 ~ 0.14				120	125	130	135	140	145	150	155	160	165	170	175	180	185	190	195	200	205	210	215	220	225			
0.15 ~ 0.18			120	125	130	135	140	145	150	155	160	165	170	175	180	185	190	195	200	205	210	215	220	225	230			
0.19 ~ 0.27	RECOMMENDED CLEARANCE																											
0.28 ~ 0.30	120	125	130	135	140	145	150	155	160	165	170	175	180	185	190	195	200	205	210	215	220	225	230	235	240			
0.31 ~ 0.35	125	130	135	140	145	150	155	160	165	170	175	180	185	190	195	200	205	210	215	220	225	230	235	240				
0.36 ~ 0.40	130	135	140	145	150	155	160	165	170	175	180	185	190	195	200	205	210	215	220	225	230	235	240					
0.41 ~ 0.45	135	140	145	150	155	160	165	170	175	180	185	190	195	200	205	210	215	220	225	230	235	240						
0.46 ~ 0.50	140	145	150	155	160	165	170	175	180	185	190	195	200	205	210	215	220	225	230	235	240							
0.51 ~ 0.55	145	150	155	160	165	170	175	180	185	190	195	200	205	210	215	220	225	230	235	240								
0.56 ~ 0.60	150	155	160	165	170	175	180	185	190	195	200	205	210	215	220	225	230	235	240									
0.61 ~ 0.65	155	160	165	170	175	180	185	190	195	200	205	210	215	220	225	230	235	240										
0.66 ~ 0.70	160	165	170	175	180	185	190	195	200	205	210	215	220	225	230	235	240											
0.71 ~ 0.75	165	170	175	180	185	190	195	200	205	210	215	220	225	230	235	240												
0.76 ~ 0.80	170	175	180	185	190	195	200	205	210	215	220	225	230	235	240													
0.81 ~ 0.85	175	180	185	190	195	200	205	210	215	220	225	230	235	240														
0.86 ~ 0.90	180	185	190	195	200	205	210	215	220	225	230	235	240															
0.91 ~ 0.95	185	190	195	200	205	210	215	220	225	230	235	240																
0.96 ~ 1.00	190	195	200	205	210	215	220	225	230	235	240																	
1.01 ~ 1.05	195	200	205	210	215	220	225	230	235	240																		
1.06 ~ 1.10	200	205	210	215	220	225	230	235	240																			
1.11 ~ 1.15	205	210	215	220	225	230	235	240																				
1.16 ~ 1.20	210	215	220	225	230	235	240																					
1.21 ~ 1.25	215	220	225	230	235	240																						
1.26 ~ 1.30	220	225	230	235	240																							
1.31 ~ 1.35	225	230	235	240																								
1.36 ~ 1.40	230	235	240																									
1.41 ~ 1.45	235	240																										
1.46 ~ 1.50	240																											

VALVE CLEARANCE (cold):
 0.19 ~ 0.27 mm (0.007 ~ 0.011 in)
Example: Installed is: 180
 Measured clearance is:
 0.34 mm (0.013 in)
 Replace 180 pad with 185 pad

Pad range		Pad availability: 25 increments
No. 120 ~ No. 240	1.20 mm (0.047 in) ~ 2.40 mm (0.094 in)	Pads are stepped in 0.05 mm (0.002 in) increments

NOTE: _____
Thickness of each pad is marked on the pad face that contacts the valve lifter (not the cam).

- Round off the hundredths digit of the original pad number to the nearest 0.05 mm increment.

Last digit of pad number	Rounded value
0 or 2	0
5	(NOT ROUNDED OFF)
8	10

EXAMPLE:
Original pad number = 178 (1.78 mm)
Rounded off digit = 180

NOTE: _____
Pads can only be selected in 0.05 mm (0.002 in) increments.

- Locate the previously installed pad number on the chart. Locate the measured valve clearance on the chart. The point where these coordinates intersect is the new pad number.
- Install the new pad ① and valve lifter ②.
- Recheck the valve clearance and adjust it if necessary.

NOTE: _____

- Apply molybdenum disulfide grease to the pad.
- Use your finger to rotate the valve lifter smoothly.

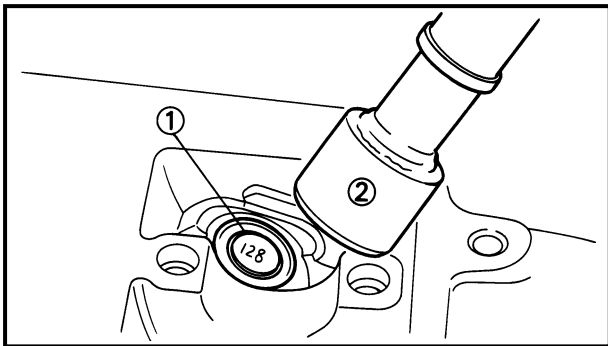

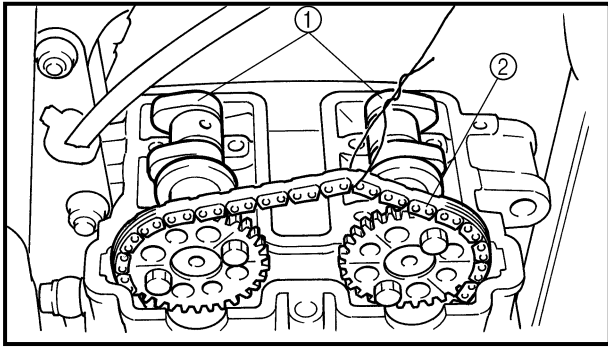

11. Install:

- Camshafts ①
- Timing chain ②
- Camshaft caps

	Bolt (camshaft caps, cam chain tensioner):
	10 Nm (1.0 m · kg, 7.2 ft · lb)
	Cap bolt (cam chain tensioner):
	8 Nm (0.8 m · kg, 5.8 ft · lb)

NOTE: _____

- Install the exhaust camshaft first.
- Align the matching marks.
- Refer to "ENGINE ASSEMBLY AND ADJUSTMENT-CYLINDER AND PISTON, CYLINDER HEAD" in CHAPTER 4.
- Apply molybdenum disulfide grease to the camshaft caps.
- Tighten the bolts (camshaft cap) in a criss-cross pattern from inside.
- Turn the crankshaft counterclockwise several turns for the installed parts to settle into the correct position.

CAU _____

The bolts (camshaft cap) must be tightened evenly, or damage to the cylinder head, camshaft caps and cam will be result.

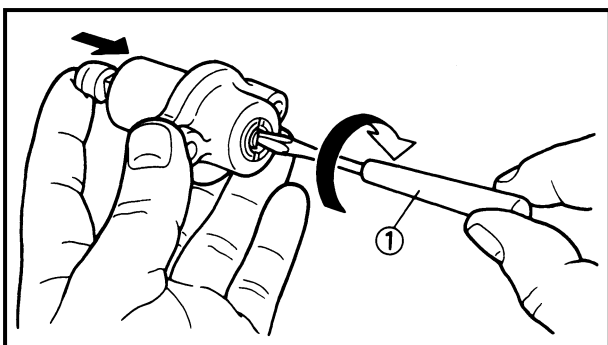

12. Install:

- Timing chain tensioner

Installing steps:

- While pressing the tensioner rod lightly with your fingers, use a thin screwdriver ① and wind the tensioner rod up fully clockwise.

VALVE CLEARANCE ADJUSTMENT

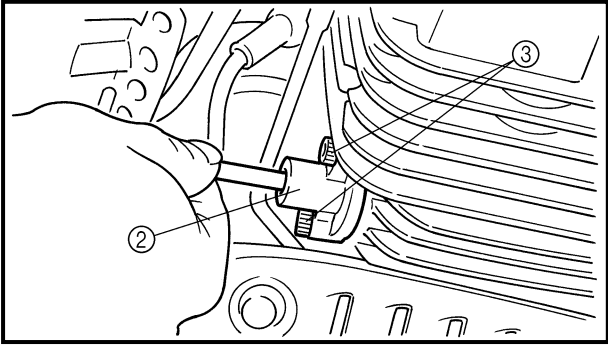

- With the rod fully wound, install the gasket and the chain tensioner (2), and tighten the bolt (3) to the specified torque.

	Bolt (3) (chain tensioner): 10 Nm (1.0 m • kg, 7.2 ft • lb)
---	--

- Release the screwdriver, check that the tensioner rod comes out and tighten the gasket and the cap bolt (4) to the specified torque.

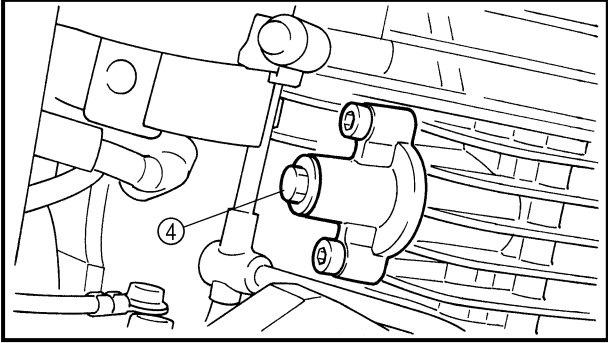

	Cap bolt (4) (timing chain tensioner): 8 Nm (0.8 m • kg, 5.8 ft • lb)
---	--

13.Measure:

- Valve clearance

Verification steps:

- Follow the valve clearance measurement steps.
- If the clearance is incorrect, repeat all adjustment steps until the proper clearance is obtained.

14.Install:

Reverse removal steps.

- Cylinder head cover
- Spark plug lead

	Bolt (cylinder head cover): 10 Nm (1.0 m • kg, 7.2 ft • lb)
---	--

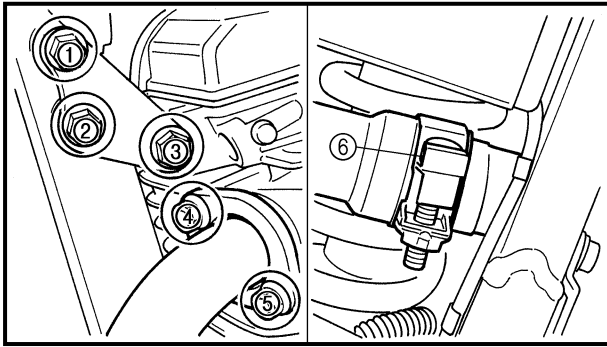

15.Install:

- Exhaust pipe

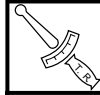

Engine mount stay ①, ②:

30 Nm (3.0 m · kg, 22 ft · lb)

Engine mount stay ③:

64 Nm (6.4 m · kg, 46 ft · lb)

Nut ④, ⑤:

20 Nm (2.0 m · kg, 14 ft · lb)

Bolt ⑥:

20 Nm (2.0 m · kg, 14 ft · lb)

16.Install:

- Side covers
- Seat
- Fuel tank

Refer to "SEAT, FUEL TANK AND COVERS".

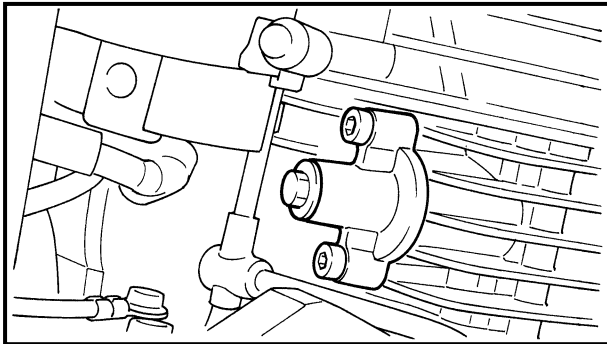

TIMING CHAIN ADJUSTMENT

Adjustment free.

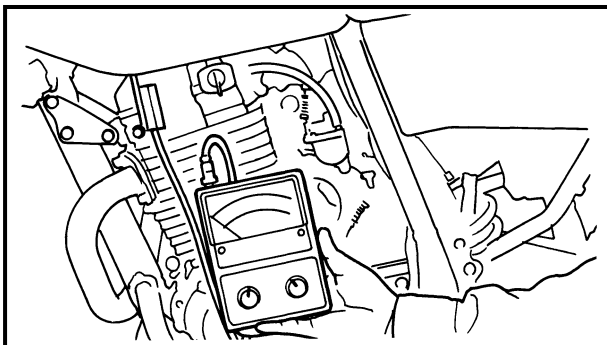

IDLING SPEED ADJUSTMENT

1.Start the engine and let it warm up for several minutes.

2.Attach:

- Inductive tachometer
To the spark plug lead.



**Inductive tachometer:
P/N. YU-8036-A**

3.Check:

- Engine idling speed
Out of specification → Adjust.



**Engine idling speed:
1,250 ~ 1,350 r/min**

IDLING SPEED ADJUSTMENT/ THROTTLE CABLE FREE PLAY ADJUSTMENT

**CHK
ADJ**

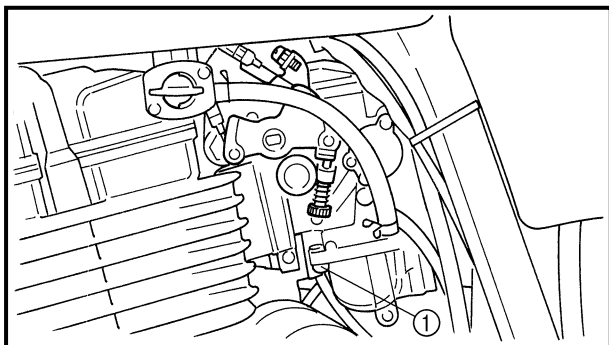

4.Adjust:

- Engine idling speed

Adjustment steps:

- Turn in the pilot screw ① until it is lightly seated.
- Turn out the pilot screw for the specified number of turns.

**Pilot screw:
1-1/2 turns out**

- Turn the throttle stop screw ② in or out until specified idling speed is obtained.

Turning in → Idling speed becomes higher.

Turning out → Idling speed becomes lower.

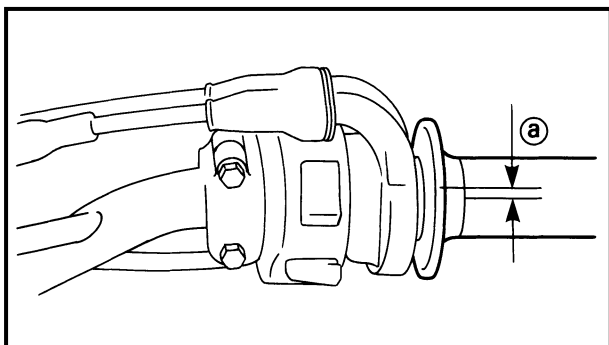
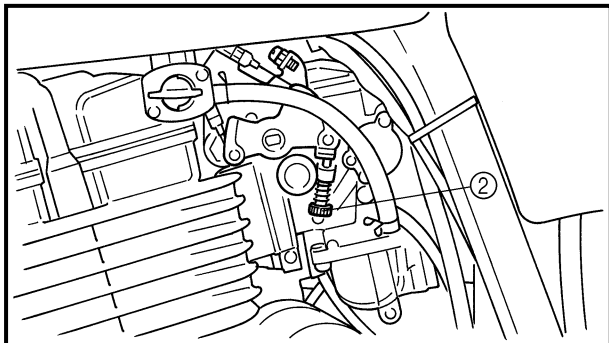

THROTTLE CABLE FREE PLAY ADJUSTMENT

NOTE:

Before adjusting the throttle cable free play, the engine idle speed should be adjusted.

1.Check:

- Throttle cable free play ①
Out of specification → Adjust.



**Throttle cable free play:
3 ~ 5 mm (0.12 ~ 0.20 in)**

2.Adjust:

- Throttle cable free play

Adjustment steps:

NOTE:

When accelerating, throttle cable #1 ① is pulled and throttle cable #2 ② is pushed.

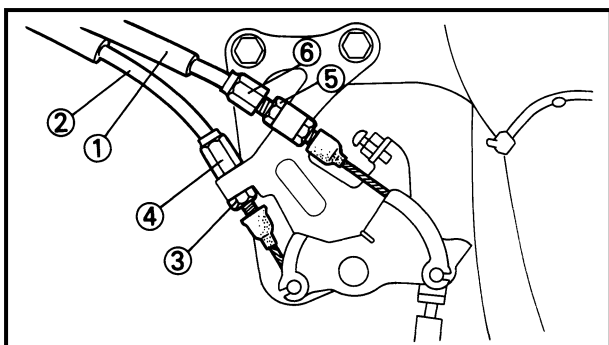



1st step:

- Loosen the locknut ③ on throttle cable #2.
- Turn the adjuster ④ in or out until all slack is removed from throttle cable #2.

2nd step:

- Loosen the locknut ⑤ on throttle cable #1.
- Turn the adjuster ⑥ in or out until the specified free play is obtained.

Turning in → Free play is increased.

Turning out → Free play is decreased.

- Tighten the locknuts.

NOTE:

If the free play can not be adjusted here, adjust it at the throttle grip side of the cable.

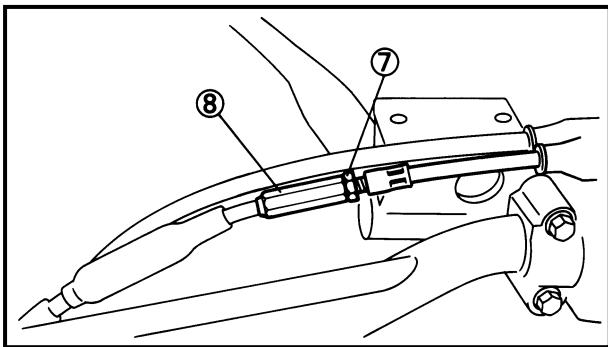

Final step:

- Loosen the locknut ⑦.
- Turn the adjuster ⑧ in or out until the specified free play is obtained.

Turning in → Free play is increased.

Turning out → Free play is decreased.

- Tighten the locknut.

⚠ WARNING

After adjusting, turn the handlebar to the right and left, making sure that the engine idling speed does not change.

SPARK PLUG INSPECTION

1. Disconnect:

- Spark plug cap

2. Remove:

- Spark plug

When removing the spark plug, use caution to prevent an object from falling into the engine.



3. Inspect:
- Spark plug type
Incorrect → Replace.

**Standard spark plug:
CR9E (NGK), U27ESR-N (DENSO)**

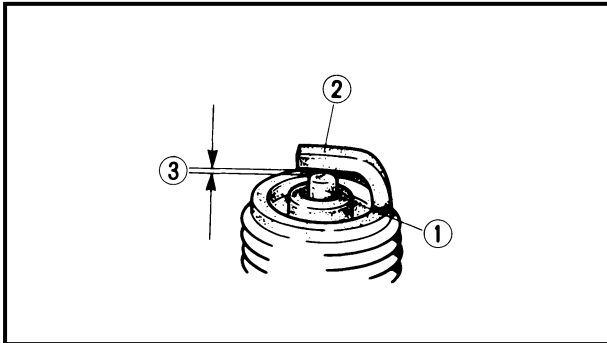

4. Inspect:
- Electrode ①
Wear/damage → Replace.
 - Insulator ②
Abnormal color → Replace.
Normal color is a medium-to-light tan color.
5. Clean the spark plug with a spark plug cleaner or wire brush.
6. Measure:
- Plug gap ③
Use a wire gauge or feeler gauge.
Out of specification → Regap.

Spark plug gap:
0.7 ~ 0.8 mm (0.028 ~ 0.031 in)

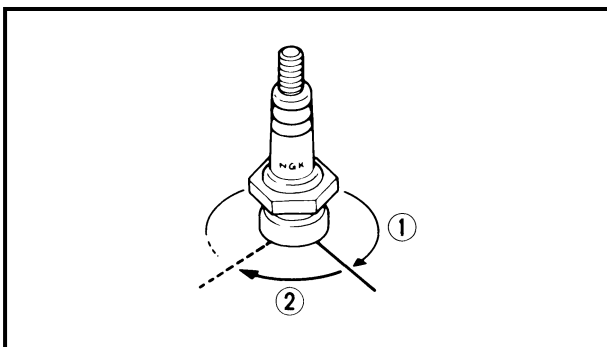

7. Tighten:
- Spark plug

Spark plug:
13 Nm (1.3 m · kg, 9.4 ft · lb)

NOTE: _____

- Before installing a spark plug, clean the gasket surface and plug surface.
- If a torque wrench is not available when you are installing a spark plug, a good estimate of the correct torque ② is 1/4 to 1/2 turns past finger tight ①. Have the spark plug torqued to the correct value as soon as possible with a torque wrench.

8. Connect:
- Spark plug cap

IGNITION TIMING CHECK

NOTE: _____
 Engine idling speed and throttle cable free play should be adjusted properly before checking the ignition timing.

1. Start the engine and let it warm up for several minutes, then stop the engine.
2. Attach:
 - Inductive tachometer
 - Timing light
To spark plug lead.

	Inductive tachometer: P/N. YU-8036-A Timing light: P/N. YM-33277-A
---	---

3. Check:
 - Ignition timing

Checking steps:

- Remove the plug.
- Start the engine and let it run at the specified speed.

	Engine speed: 1,250 ~ 1,350 r/min
---	---

CAUTION

Under extreme conditions, the oil may spurt out when running the engine. Therefore care should be used.

- Visually check the stationary pointer ① to verify it is within the required firing range ② indicated on the flywheel.
 Incorrect firing range → Check the pickup coil assembly.

NOTE: _____
 Ignition timing is not adjustable.

4. Install:
 - Plug
5. Detach:
 - Timing light
 - Inductive tachometer

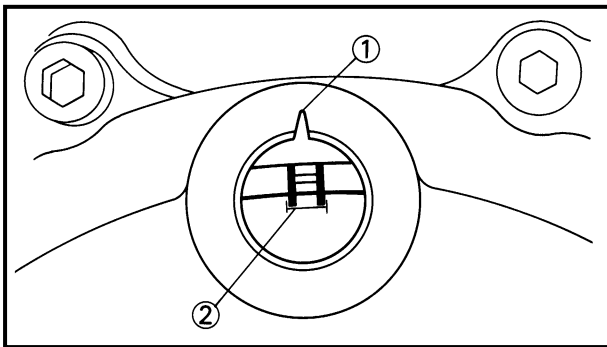

COMPRESSION PRESSURE MEASUREMENT

NOTE: _____
Insufficient compression pressure will result in performance loss.

1. Check:
 - Valve clearance
Out of specification → Adjust.
Refer to "VALVE CLEARANCE ADJUSTMENT".
2. Start the engine and let it warm up for several minutes.
3. Stop the engine.
4. Disconnect:
 - Spark plug cap
5. Remove:
 - Spark plug
Refer to "SPARK PLUG INSPECTION".
6. Attach:
 - Compression gauge ①
 - Adapter ②

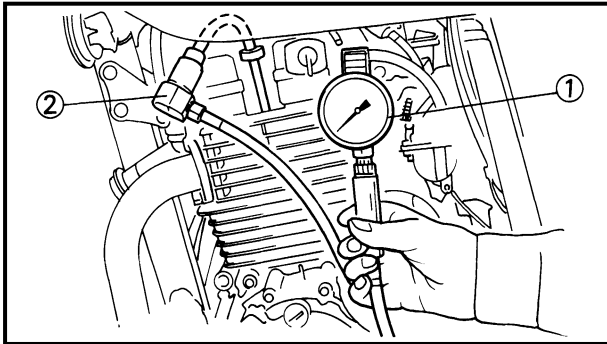

	Compression gauge: P/N. YU-33223 Adapter: P/N. YU-33223-3
--	--

7. Check:
 - Compression pressure

Checking steps:

- Crank over the engine with the electric starter (be sure the battery is fully charged) with the throttle wide-open until the compression reading on the gauge stabilizes.

⚠ WARNING _____
When cranking the engine, ground the spark plug lead to prevent sparking.

- Check the reading with the specified levels (see table).

Compression pressure (at sea level):
Standard:
 1,200 kPa (12 kg/cm², 174 psi)
Minimum:
 1,000 kPa (10 kg/cm², 145 psi)
Maximum:
 1,300 kPa (13 kg/cm², 189 psi)

- If pressure falls below the minimum level:
 - 1) Squirt a few drops of oil into the affected cylinder.
 - 2) Measure the compression again.

Compression pressure (with oil introduced into cylinder)	
Reading	Diagnosis
Higher than without oil	Worn or damaged pistons
Same as without oil	Defective ring(s), valves, cylinder head gasket or piston is possible.
Above maximum level	Inspect cylinder head, valve surfaces, or piston crown for carbon deposits.

8. Install:
- Spark plug

	Spark plug: 13 Nm (1.3 m · kg, 9.4 ft · lb)
---	---

Refer to "SPARK PLUG INSPECTION".

9. Connect:
- Spark plug cap

ENGINE OIL LEVEL INSPECTION

NOTE: _____
 Position the motorcycle straight up when checking the oil level as slight tilt to the side can produce false readings.

1. Place the motorcycle on a level place.
2. Warm up the engine for several minutes.
3. Stop the engine and visually check the oil level through the level window.

ENGINE OIL LEVEL INSPECTION/ ENGINE OIL REPLACEMENT

CHK
ADJ

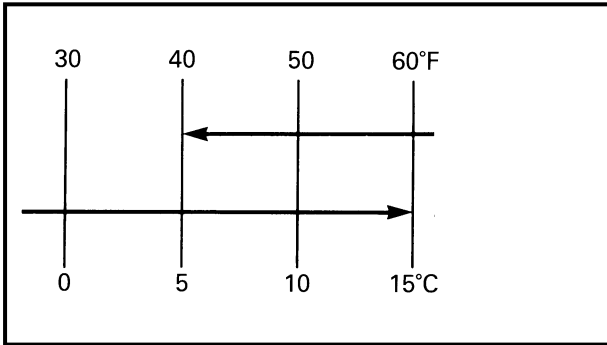
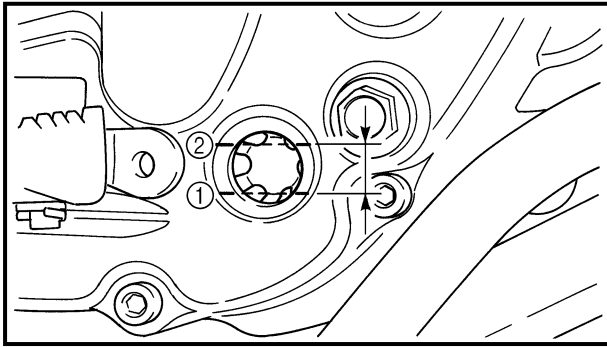

4. Inspect:

- Oil level
Oil level should be between maximum ① and minimum ② marks.
Low oil level → Add oil to proper level.

NOTE:

Wait a few minutes until level settles before inspecting.



Recommended oil:

SAE 20W40 type SE motor oil or
SAE 10W30 type SE motor oil

CAUTION

- Do not add any chemical additives. Engine oil also lubricates the clutch and additives could cause clutch slippage.
- Do not allow foreign material to enter the crankcase.

5. Install:

- Oil filler cap

6. Start the engine and warm up for several minutes.

When the oil tank is empty, never start the engine.

7. Stop the engine and inspect the oil level once again.



Oil quantity:

Periodic oil change:

1.1 L (0.97 Imp qt, 1.16 US qt)

With oil filter replacement:

1.2 L (1.06 Imp qt, 1.27 US qt)

Total amount:

1.45 L (1.28 Imp qt, 1.53 US qt)

ENGINE OIL REPLACEMENT

- Do not add any chemical additives. Engine oil also lubricates the clutch and additives could cause clutch slippage.
- Do not allow foreign material to enter the crankcase.

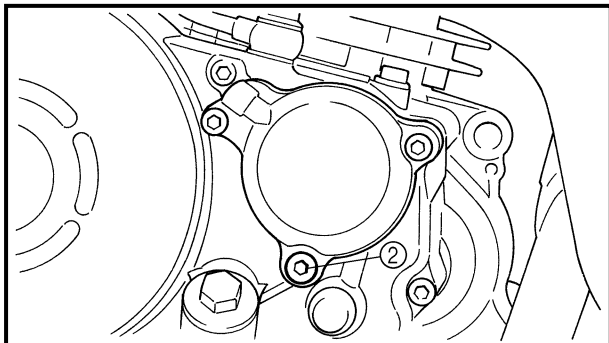
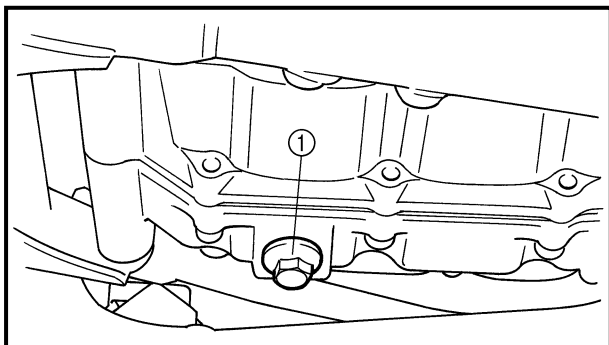

Engine oil replacement (without oil filter)

1. Place the motorcycle on a level place.
2. Warm up the engine for several minutes, then stop the engine. Then place a receptacle under the drain plug.
3. Remove:
 - Drain plug ①
4. Drain:
 - Engine oil

5. Remove:
 - Bolt ② (oil filter cover-lower)

NOTE: _____
The oil filter cover is secured by three screws. The lower one should be removed so that the filter cavity will drain.

6. Inspect:
 - Washer (drain plug)
Damage → Replace.

7. Install:
 - Bolt ② (oil filter cover-lower)
 - Drain plug

	Drain plug ① (crankcase): 20 Nm (2.0 m · kg, 14 ft · lb)
	Bolt ② (oil filter cover-lower): 10 Nm (1.0 m · kg, 7.2 ft · lb)

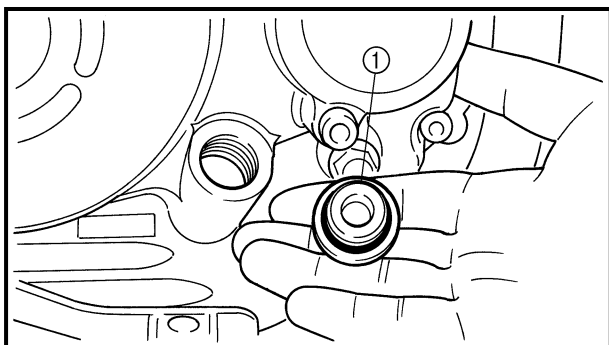

8. Remove:
 - Oil filler cap ①
9. Fill:
 - Crankcase

	Periodic oil change: 1.1 L (0.97 Imp qt, 1.16 US qt)
--	--

- Do not allow foreign material to enter the crankcase.
- Do not add any chemical additives. Engine oil also lubricates the clutch and additives could cause clutch slippage.

10. Install:
 - Oil filler cap



11. Inspect:

- Oil level
Refer to "ENGINE OIL LEVEL INSPECTION".
- Oil pressure
Refer to "OIL PRESSURE INSPECTION".
- Oil leaks

Engine oil replacement (with oil filter)

1. Place the motorcycle on a level place.
2. Warm up the engine for several minutes, then stop the engine. Then place a receptacle under the drain plug.
3. Remove:
 - Drain plug
4. Drain:
 - Engine oil
5. Remove:
 - Screw (oil filter cover-lower)

NOTE:

The oil filter cover is secured by three screws. The lower one should be removed so that the filter cavity will drain.

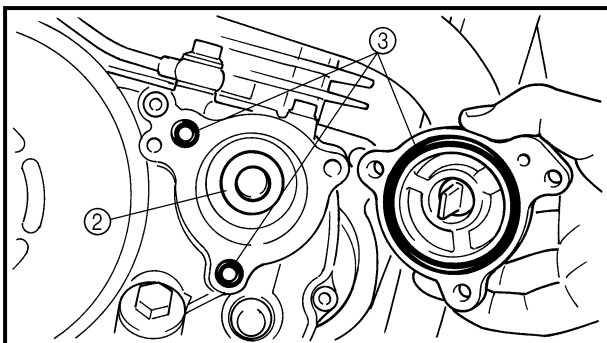
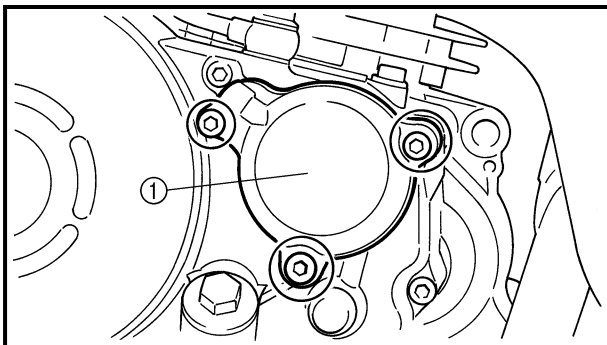

6. Remove:

- Oil filter cover ①
- Oil filter ②
- O-ring ③



7. Inspect:
- O-ring
Damage → Replace.
8. Clean:
- Oil filter
Clean it with solvent.
Clog/damage → Replace.

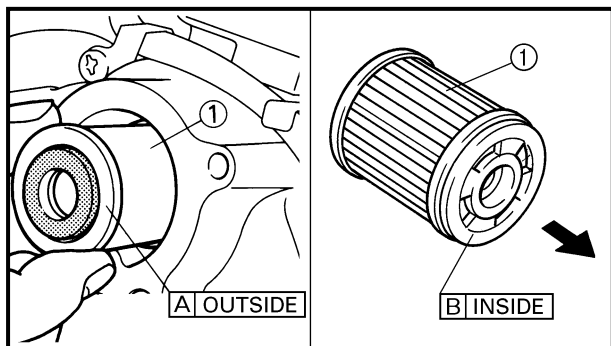

9. Install:
- Oil filter ①

Install the oil filter as shown.

- Oil filter cover
- Drain plug (crankcase)

	Bolt (oil filter):
	10 Nm (1.0 m • kg, 7.2 ft • lb)
	Drain plug (crankcase):
	20 Nm (2.0 m • kg, 14 ft • lb)

10. Remove:
- Oil filler cap
11. Fill:
- Crankcase

	With oil filter replacement:
	1.2 L (1.06 Imp qt, 1.27 US qt)

CAU

- Do not allow foreign material to enter the crankcase.
- Do not add any chemical additives. Engine oil also lubricates the clutch and additives could cause clutch slippage.

12. Install:
- Oil filler cap
13. Inspect:
- Oil level
Refer to "ENGINE OIL LEVEL INSPECTION".
 - Oil pressure
Refer to "OIL PRESSURE INSPECTION".
 - Oil leaks

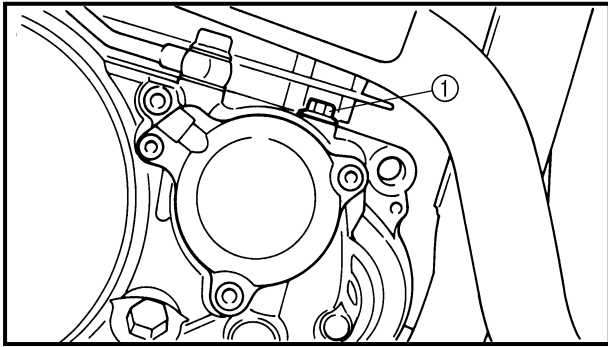

OIL PRESSURE INSPECTION

1. Remove:
 - Oil check bolt ①
2. Start the engine and keep it idling for several minutes.
3. Inspect:
 - Oil condition of the bleed hole
Oil flows out → Oil pressure is good.
No oil comes out → Oil pressure is bad.

If no oil comes out after a lapse of one minute, turn off the engine immediately so it will not seize.

4. Tighten:
 - Oil check bolt

	Oil check bolt ①: 7 Nm (0.7 m · kg, 5.1 ft · lb)
---	---

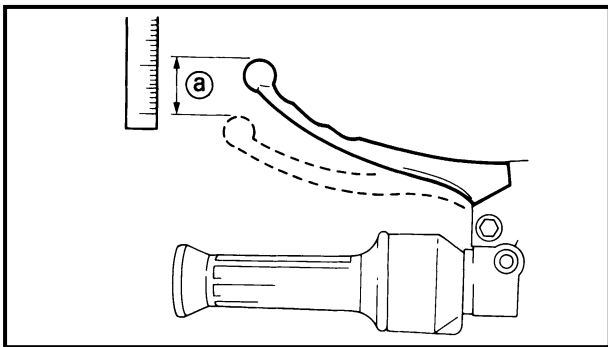

YB2AF000

CLUTCH ADJUSTMENT

1. Check:
 - Clutch cable free play ②
Out of specification → Adjust.

	Free play: 10 ~ 15 mm (0.4 ~ 0.6 in) at clutch lever end
---	---

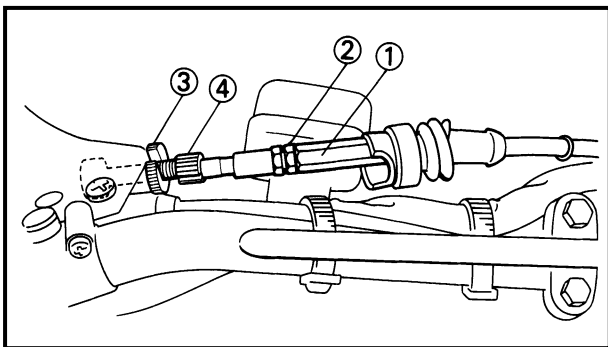

2. Adjust:
 - Clutch cable free play

Adjustment steps:

1st step:

- Make sure that the adjuster ① and locknut ② are fully tightened.
- Loosen the locknut ③.
- Turn the adjusting nut ④ in or out until the specified free play is obtained.

Turning in → Free play is increased.
Turning out → Free play is decreased.

- Tighten the locknut ③.

NOTE:

If the free play is incorrect, adjust the clutch cable free play with the adjuster (part of clutch lever holder).



2nd step:

- Loosen the locknut ②.
- Turn the adjuster ① in or out until the correct free play is obtained.

Turning in → Free play is increased.

Turning out → Free play is decreased.

- Tighten the locknut ②.

AIR FILTER CLEANING

NOTE:

There is a check hose ① at the bottom of the air filter case. If dust and/or water collects in this hose, clean the air filter element and air filter case.

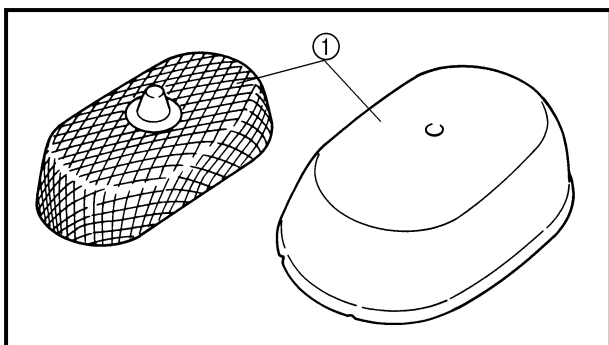
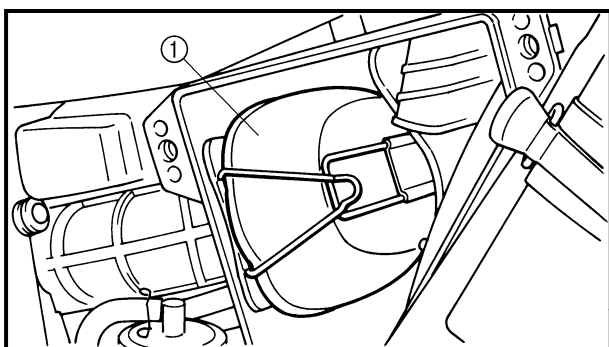
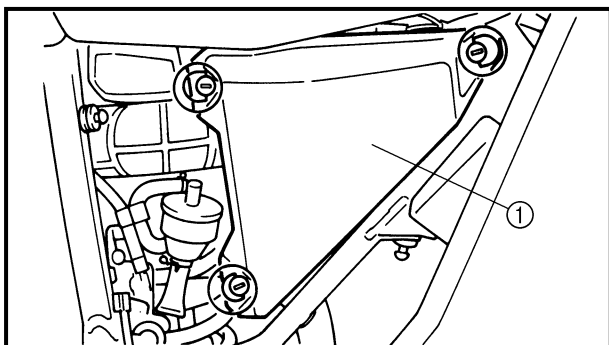
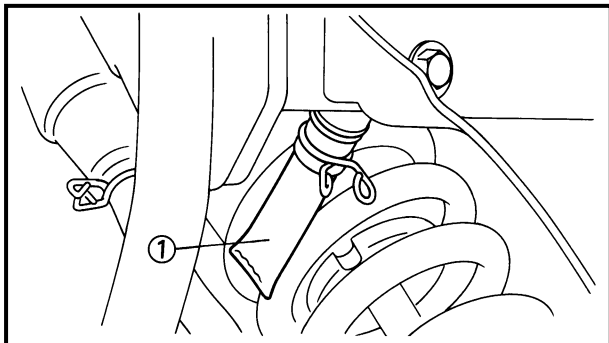

1.Remove:

- Side cover (left)
Refer to "SEAT, FUEL TANK AND COVERS".
- Air filter case cover ①
Refer to "REAR SHOCK ABSORBER AND SWINGARM" in CHAPTER 6.

2.Remove:

- Air filter element assembly ①

Never operate the engine with the air filter element removed. This will allow unfiltered air to enter, causing rapid wear and possible engine damage. Additionally, operation without the filter element will affect carburetor tuning with subsequent poor performance and possible engine overheating.

3.Inspect:

- Air filter element assembly ①
Damage → Replace.

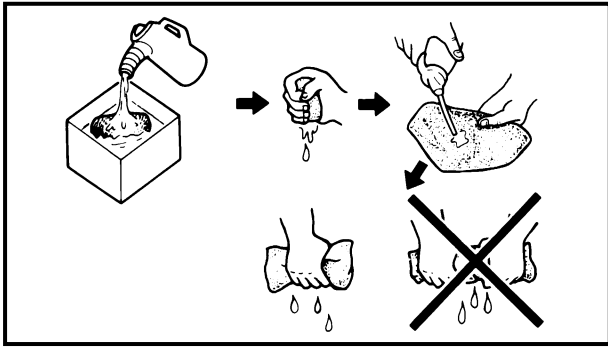

4.Clean:

- Air filter element
Clean it with solvent.

NOTE:

After cleaning, remove the remaining solvent by squeezing the element.

CAU

Do not twist the filter element when squeezing the filter element.

⚠ WARNING

Never use low flash point solvents such as gasoline to clean the air filter element. Such solvent may lead to a fire or explosion.

- 5.Apply recommended oil to the entire surface of the filter and squeeze out the excess oil. The element should be wet but not dripping.

Recommended oil:
SAE 20W40 type SE motor oil or
SAE 10W30 type SE motor oil

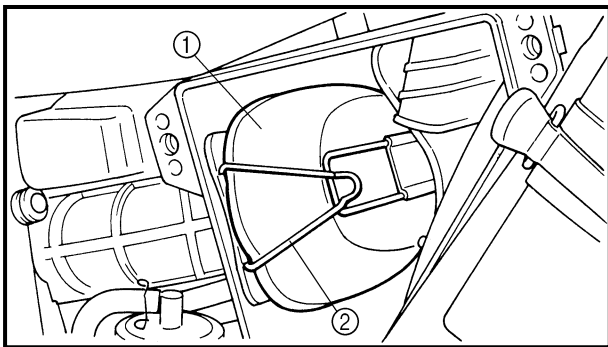

6.Install:

- Air filter element ①
- Band ②

7.Install:

- Air filter case cover
- Side cover (left)

 **Bolt (side cover):**
7 Nm (0.7 m • kg, 5.1 ft • lb)

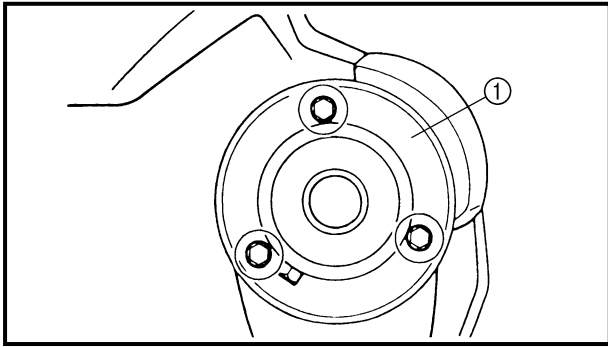

SPARK ARRESTER CLEANING

1. Select a well-ventilated area free of combustible materials and make sure the exhaust and muffler are cool.

2. Remove:

- Spark arrester ①

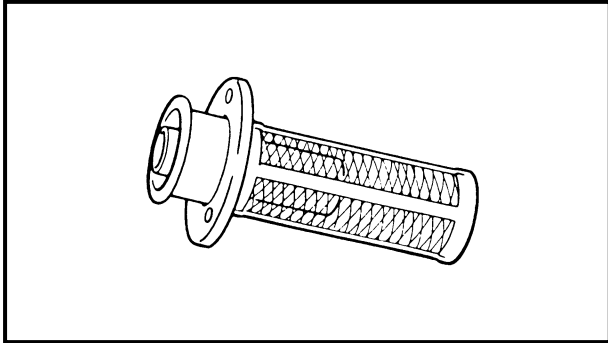

3. Clean:

- Spark arrester with wire brush

4. Install:

- Spark arrester

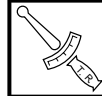

Bolt (spark arrester):
7 Nm (0.7 m • kg, 5.1 ft • lb)

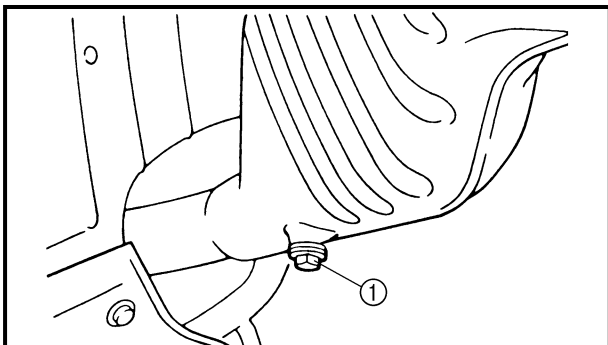

5. Remove:

- Purging bolt ①

6. Start the engine and rev it up approximately twenty times while momentarily creating exhaust system back pressure by blocking the end of the muffler with a shop towel.

7. Stop the engine and allow the exhaust pipe to cool.

8. Install:

- Purging bolt

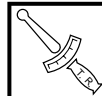

Purging bolt ①:
20 Nm (2.0 m • kg, 14 ft • lb)

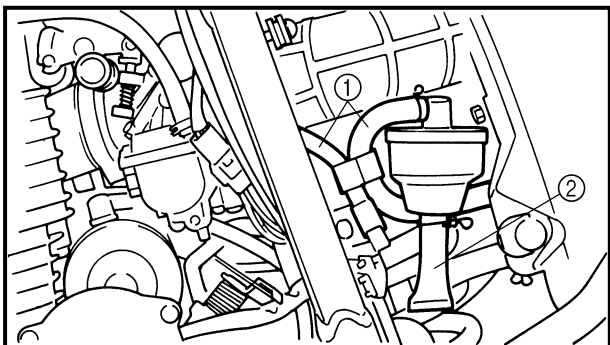

CRANKCASE BREATHER HOSE INSPECTION

1. Inspect:
- Breather hose ①
Cracks/damage → Replace.
 - Check hose ②
Drain oil/water → Clean.

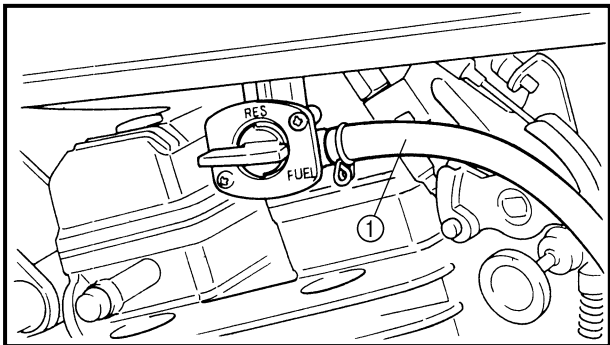

FUEL LINE INSPECTION

1. Inspect:
- Fuel hose ①
Cracks/damage → Replace.

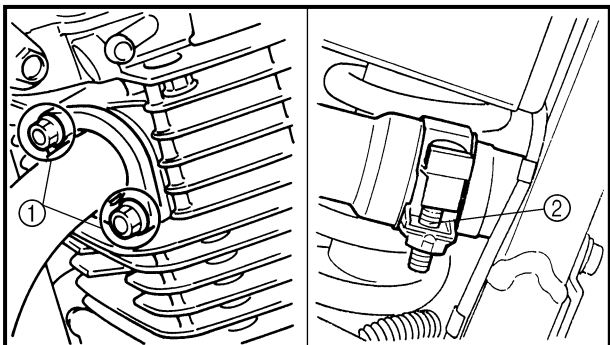

EXHAUST SYSTEM INSPECTION

1. Inspect:
- Exhaust pipe
 - Muffler
Cracks/damage → Replace.
 - Gasket
Exhaust gas leaks → Replace.
2. Tighten:
- Exhaust pipe
 - Muffler

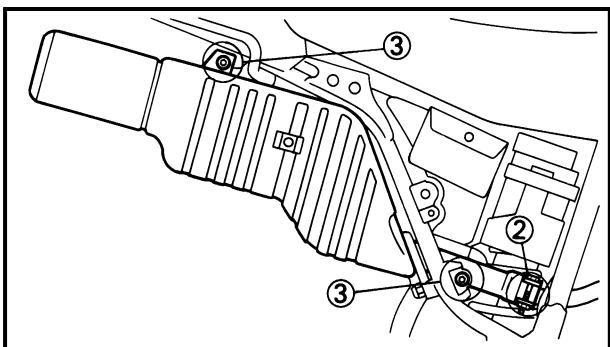

	Nuts (exhaust pipe) ①:
	20 Nm (2.0 m • kg, 14 ft • lb)
	Bolt ②:
	20 Nm (2.0 m • kg, 14 ft • lb)
	Bolt ③:
	40 Nm (4.0 m • kg, 29 ft • lb)

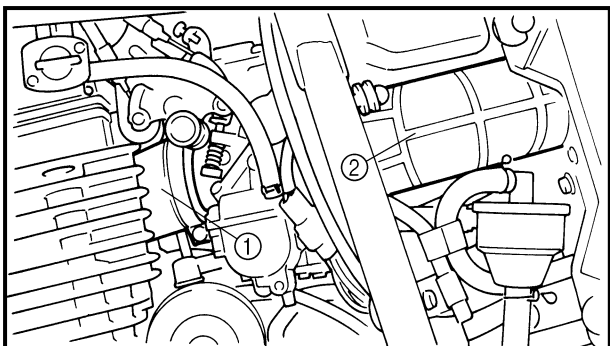

CARBURETOR JOINT INSPECTION

1. Inspect:
- Carburetor joint ①, ②
Cracks/damage → Replace.

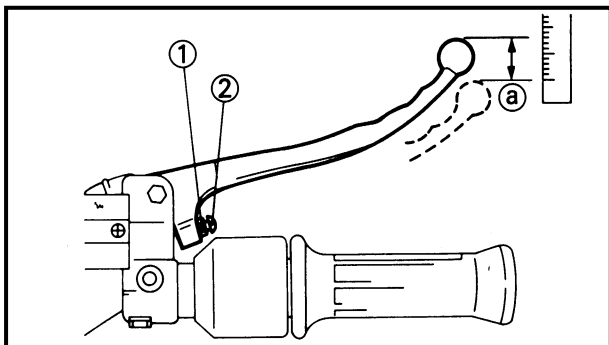

CHASSIS

FRONT BRAKE ADJUSTMENT

1. Check:

- Brake lever free play (a)
Out of specification → Adjust.

	Free play:
	2 ~ 5 mm (0.08 ~ 0.20 in)

2. Adjust:

- Brake lever free play

Adjustment steps:

- Loosen the locknut (1).
- Turn the adjuster (2) in or out until the specified free play is obtained.

Turning in → Free play is increased.

Turning out → Free play is decreased.

- Tighten the locknut.

Proper lever free play is essential to avoid excessive brake drag.

⚠ WARNING

A soft or spongy feeling in the brake lever can indicate the presence of air in the brake system. This air must be removed by bleeding the brake system before the motorcycle is operated. Air in the system will cause greatly diminished braking capability and can result in loss of control and an accident. Inspect and bleed the system if necessary.

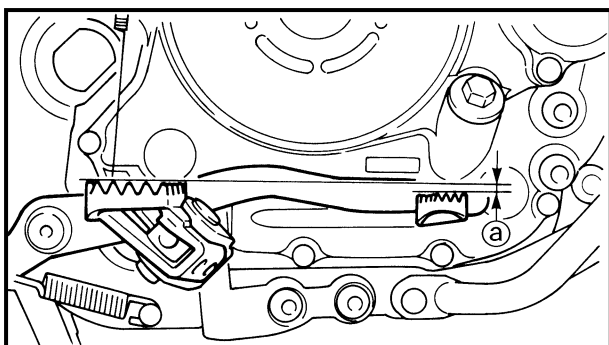

REAR BRAKE ADJUSTMENT

1. Check:

- Brake pedal height (a)
Out of specification → Adjust.

	Brake pedal height:
	10 mm (0.39 in) Below top of footrest.

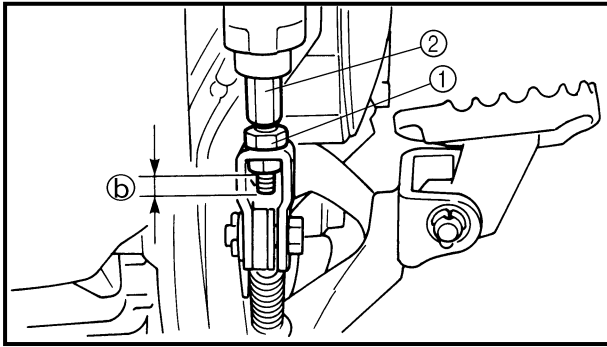

- 2.Adjust:
- Brake pedal height

Adjustment steps:

- Loosen the locknut ①.
- Turn the adjuster ② in or out until the specified pedal height is obtained.

Turning in	Pedal height is increased.
Turning out	Pedal height is decreased.

⚠ WARNING

After adjusting the brake pedal height, visually check the adjuster end. The adjuster end must appear within 3.0 ~ 5.0 mm (0.12 ~ 0.20 in) ⑥.

- Tighten the locknut ①

	Locknut ①: 18 Nm (1.8 m • kg, 13 ft • lb)
---	---

Make sure that the brake does not drag after adjusting it.

⚠ WARNING

A soft or spongy feeling in the brake pedal can indicate the presence of air in the brake system. This air must be removed by bleeding the brake system before the motorcycle is operated. Air in the system will cause greatly diminished braking capability and can result in loss of control and an accident. Inspect and bleed the system if necessary.

- 3.Adjust:
- Brake light switch

Refer to "BRAKE LIGHT SWITCH ADJUSTMENT".

NB1A3008

BRAKE FLUID LEVEL INSPECTION

NOTE: _____
 Position the motorcycle straight up when inspecting the fluid level.

1. Place the motorcycle on a level surface.

NOTE: _____
 Place the motorcycle on its centerstand if a centerstand is equipped. If not, place a suitable stand under the motorcycle.

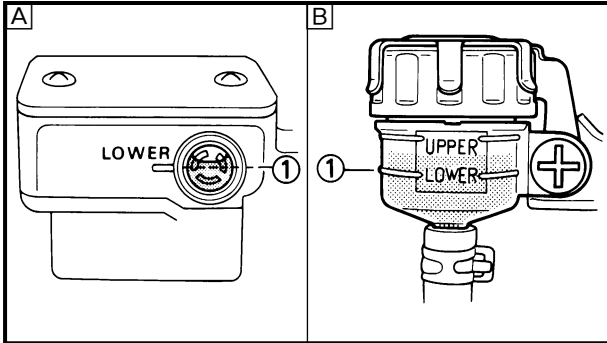

2. Inspect:

- Fluid level
 Fluid level is under "LOWER" level line ①
 → Fill to proper level.

- Ⓐ Front
- Ⓑ Rear



Recommended fluid:

Front:
 DOT #4

Rear:
 DOT #4

NOTE: _____
 When inspecting the fluid level of the reservoir at the handlebars, make sure the master cylinder top is horizontal.

CAUTION _____
 The fluid may corrode painted surfaces of plastic parts. Always clean up spilled fluid immediately.

- ⚠ WARNING** _____
- Use only the designated quality fluid. Otherwise, the rubber seals may deteriorate causing leakage and poor brake performance.
 - Refill with the same type of fluid. Mixing fluids may result in a harmful chemical reaction leading to poor brake performance.
 - Be careful that water does not enter the master cylinder when refilling. Water will significantly lower the boiling point of the fluid and may result in vapor lock.

NB1A3013

AIR BLEEDING (HYDRAULIC BRAKE SYSTEM)

⚠ WARNING

Bleed the brake system if:

- The system has been disassembled.
- A brake hose has been loosened or removed.
- The brake fluid is very low.
- The brake operation is faulty.

A loss of braking performance may occur if the brake system is not properly bled.

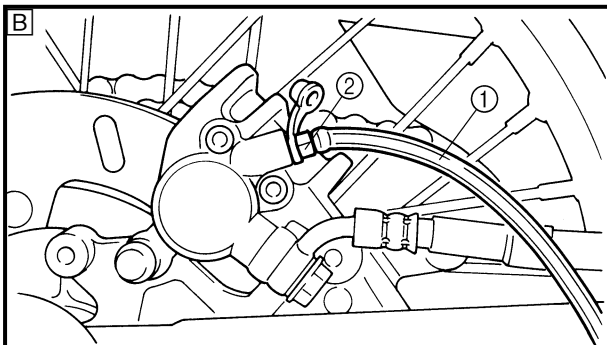
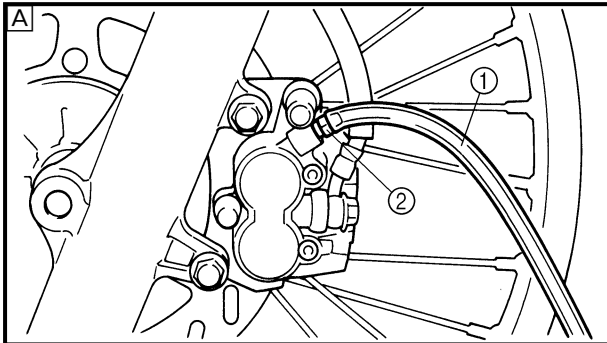

1. Bleed:

- Brake fluid

Air bleeding steps:

- a. Add proper brake fluid to the reservoir.
- b. Install the diaphragm. Be careful not to spill any fluid or allow the reservoir to overflow.
- c. Connect a clear plastic tube ① tightly to the caliper bleed screw ②.

A Front

B Rear

- d. Place the other end of the tube into a container.
- e. Slowly apply the brake lever or pedal several times.
- f. Pull the lever in or push down on the pedal.
Hold the lever or pedal in position.
- g. Loosen the bleed screw and allow the lever or pedal to travel towards its limit.
- h. Tighten the bleed screw when the lever or pedal limit has been reached, then release the lever or pedal.

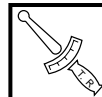

Bleed screw ②:
6 Nm (0.6 m • kg, 4.3 ft • lb)

- i. Repeat steps (e) to (h) until the air bubbles have been removed from the system.

NOTE:

If bleeding is difficult, it may be necessary to let the brake fluid system stabilize for a few hours. Repeat the bleeding procedure when the tiny bubbles in the system have disappeared.

- j. Add brake fluid to proper level.



Recommended fluid:

**Front:
DOT #4
Rear:
DOT #4**

⚠ WARNING

Check the operation of the brake after bleeding the brake system.

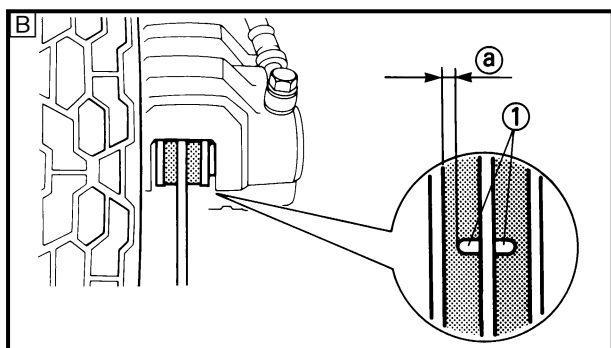
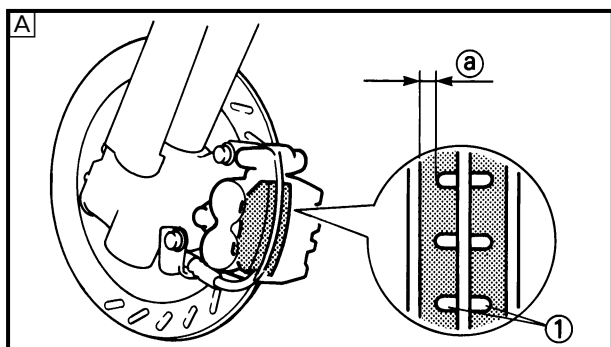

NB1A3009

BRAKE PAD INSPECTION

1. Activate the brake lever or brake pedal.
2. Inspect:
 - Brake pad
 - Wear indicator ① nearly contacting brake disc → Replace brake pads as a set.



Wear limit (a):

**Front: 1.0 mm (0.04 in)
Rear: 1.0 mm (0.04 in)**

Refer to "BRAKE PAD REPLACEMENT" in CHAPTER 6.

- A** Front
- B** Rear

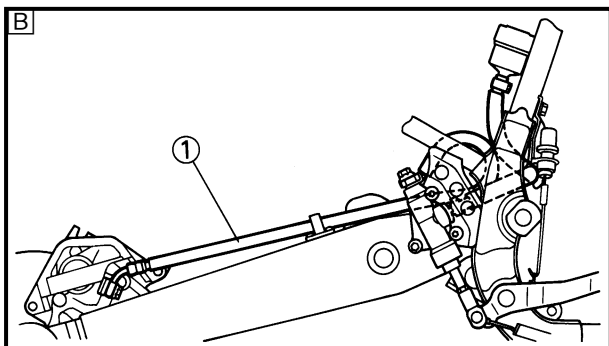
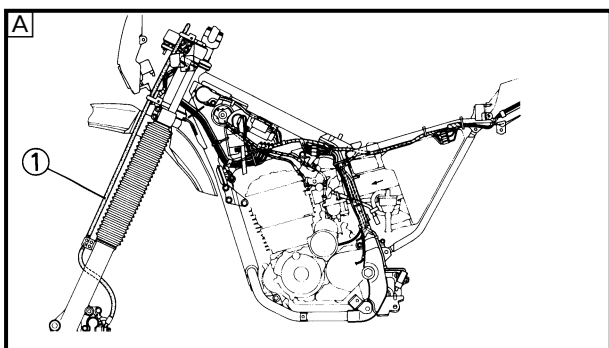

NB1A3012

BRAKE HOSE INSPECTION

⚠ WARNING

Securely support the motorcycle so there is no danger of it falling over.

1. Place the motorcycle on a level place.
2. Inspect:

- Brake hose(s) ①
Cracks/wear/damage → Replace.

A Front

B Rear

3. Hold the motorcycle on upright position and apply the front brake and/or rear brake.

4. Check:

- Fluid leakage
Active the brake lever and/or brake pedal several times.

Fluid leakage → Replace.

Refer to "FRONT AND REAR BRAKE" in CHAPTER 6.

NB1A4007

DRIVE CHAIN SLACK ADJUSTMENT

NOTE:

Before checking and/or adjusting, rotate the rear wheel several revolutions and check slack at several points to find the tightest point. Check and/or adjust the chain slack with the rear wheel in its "tightest" position.

CAU

Too little chain slack will overload the engine and other vital parts. Keep the slack within the specified limits.

⚠ WARNING

Securely support the motorcycle so there is no danger of it falling over.

1. Place the motorcycle on its centerstand.

NOTE:

Elevate the rear wheel by placing a suitable stand under the engine if a centerstand is not equipped.

DRIVE CHAIN SLACK ADJUSTMENT

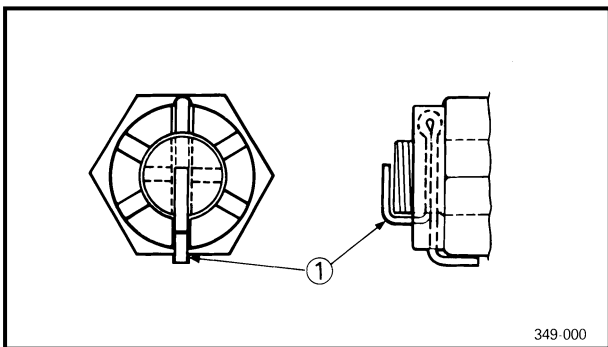
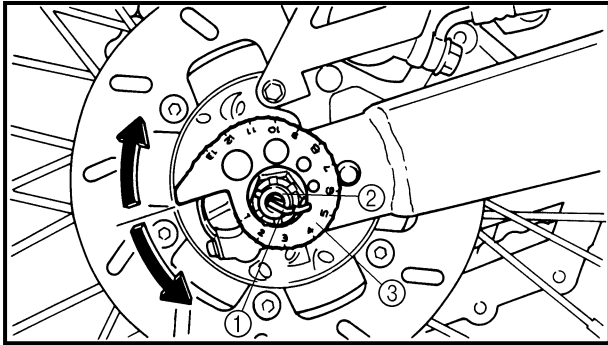
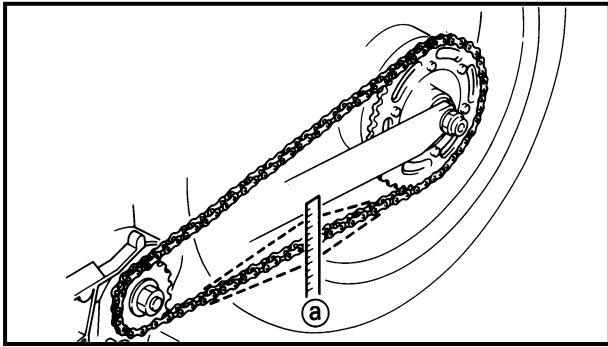

349 000

2.Check:

- Drive chain slack ①
Out of specification → Adjust.



Drive chain slack:
35 ~ 50 mm (1.38 ~ 1.97 in)
with elevated rear wheel

3.Adjust:

- Drive chain slack

Adjustment steps:

- Remove the cotter pin ① and loosen the axle nut ②.
- Turn the chain pullers ③ clockwise or counterclockwise until the specified slack is obtained.

Turning clockwise → Slack is decreased.

Turning counterclockwise → Slack is increased.

NOTE:

Turn each chain puller exactly the same amount to maintain correct axle alignment. (There are marks on each chain puller. Use them to check for proper alignment.)

- Tighten the axle nut to specification, while pushing up or down on the chain to zero slack.



Axle nut ②:
105 Nm (10.5 m • kg, 75 ft • lb)

4.Install:

- Cotter pin ①

CAUTION

Do not loosen the axle nut after torque tightening. If the axle nut groove is not aligned with the cotter pin hole, align groove with the hole by tightening up on the axle nut.

WARNING

Always use a new cotter pin.



DRIVE CHAIN LUBRICATION

The chain consists of many parts which work against each other. If the chain is not maintained properly, it will wear out rapidly, therefore, form the habit of periodically servicing the chain. This service is especially necessary when riding in dusty conditions.

This motorcycle has a drive chain with small rubber O-rings between the chain plates.

Steam cleaning, high-pressure washes, and certain solvents can damage these O-rings. Use only kerosene to clean the drive chain. Wipe it dry, and thoroughly lubricate it with SAE 30 ~ 50W motor oil. Do not use any other lubricants on the drive chain. They may contain solvents that could damage the O-rings ①.

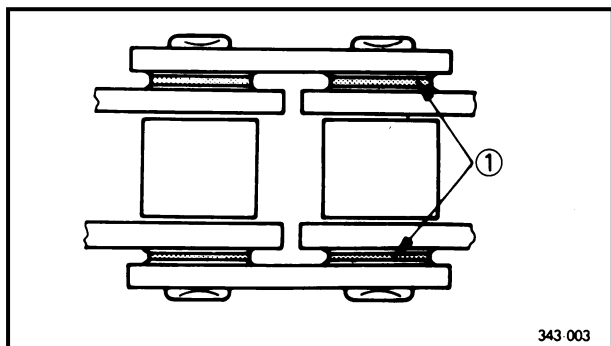

Recommended lubricant:
SAE 30 ~ 50W motor oil or chain lubricants suitable for "O-ring" chains.

STEERING HEAD ADJUSTMENT

⚠ WARNING

Securely support the motorcycle so there is no danger of it falling over.

1. Place the motorcycle on a level place.
2. Elevate the front wheel by placing a suitable stand under the frame and engine.
3. Check:
 - Steering assembly bearings
Grasp the bottom of the forks and gently rock the fork assembly back and forth.
Looseness → Adjust steering head.
4. Adjust:
 - Steering head

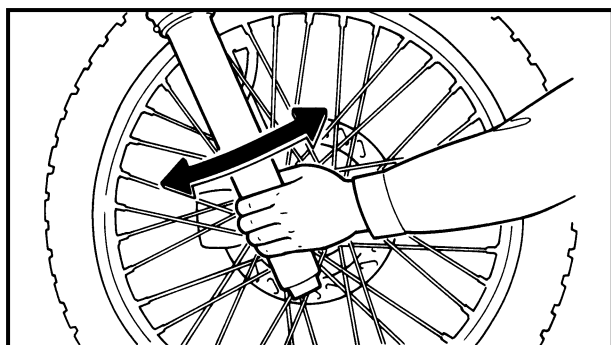

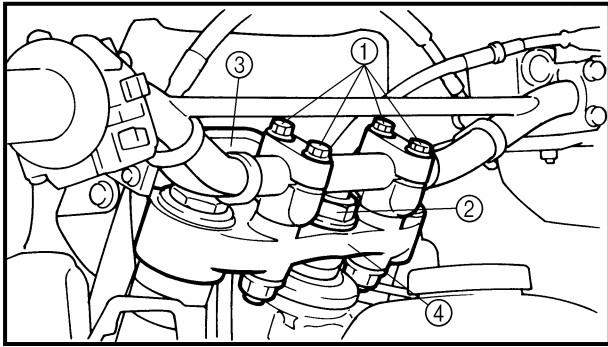

5.Remove:

- Bolts (handlebar) ①
- Nut (steering shaft) ②
- Speedometer ③
- Upper bracket ④
- Pinch bolts (upper bracket)

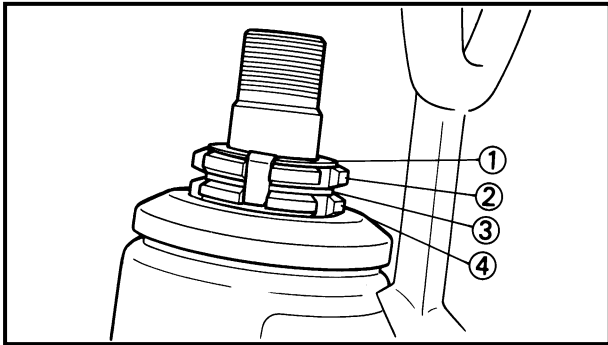

6.Adjust:

- Steering head

Adjustment steps:

- Remove the lock washer ①.
- Remove the ring nut (upper) ② and damper collar ③, then loosen the ring nut (lower) ④.
- Tighten the ring nut (lower) using ring nut wrench ⑤.

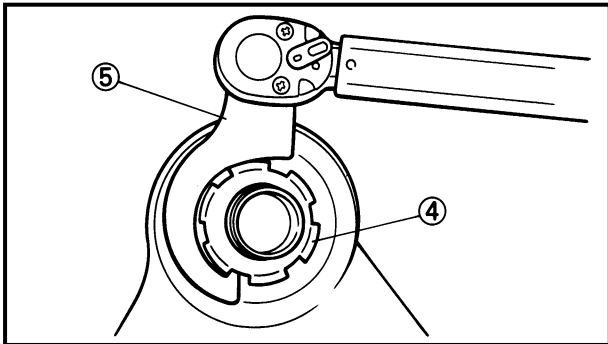

NOTE:

Set the torque wrench to the ring nut wrench so that they form a right angle.

	Ring nut wrench: P/N. YU-33975
---	--

	Ring nut-lower ④ (initial tightening): 38 Nm (3.8 m • kg, 27 ft • lb)
---	---

- Loosen the ring nut (lower) one turn.
- Retighten the ring nut (lower) using the ring nut wrench.

	Ring nut-lower ④ (final tightening): 5 Nm (0.5 m • kg, 3.6 ft • lb)
---	---

⚠ WARNING

Avoid overtightening.

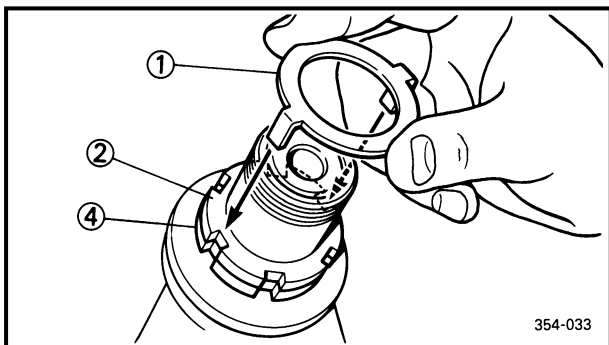

- Check the steering stem by turning it lock to lock. If there is any binding, remove the steering stem assembly and inspect the steering bearings.
- Install the damper collar and ring nut (upper) ②.
- Finger tighten the ring nut (upper) ②, then align the slots of both ring nuts. If not aligned, hold the ring nut (lower) ④ and tighten the other until they are aligned.
- Install the lock washer ①.

NOTE: _____
Make sure the lock washer tabs are placed in the slots.

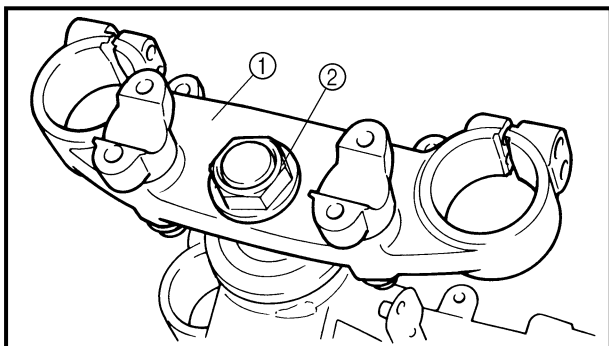

- 7.Install:
- Upper bracket ①
 - Nut ②
- Refer to "STEERING HEAD AND HANDLEBAR" in CHAPTER 6.

	Cap nut ② (steering shaft): 120 Nm (12 m • kg, 85 ft • lb)
---	---

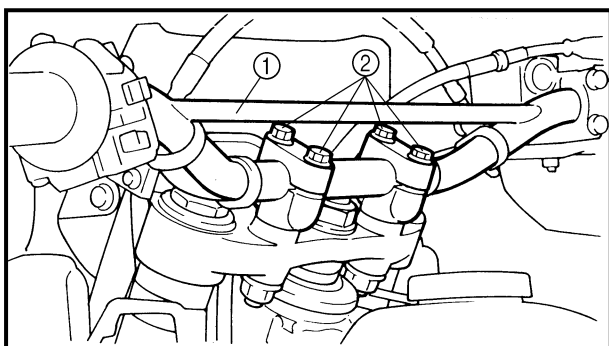

- 8.Install:
- Handlebar ①
 - Bolts ② (handlebar crown)
 - Pinch bolts (upper bracket)

	Bolt ② (handlebar crown): 23 Nm (2.3 m • kg, 17 ft • lb)
	Pinch bolt (upper bracket): 23 Nm (2.3 m • kg, 17 ft • lb)

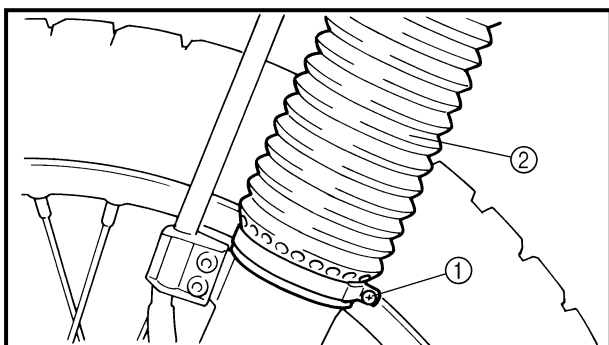

NB2A1001
FRONT FORK INSPECTION

⚠ WARNING _____
Securely support the motorcycle so there is no danger of it falling over.

- 1.Place the motorcycle on a level place.
- 2.Remove:
 - Band ①
 - Fork boots ②

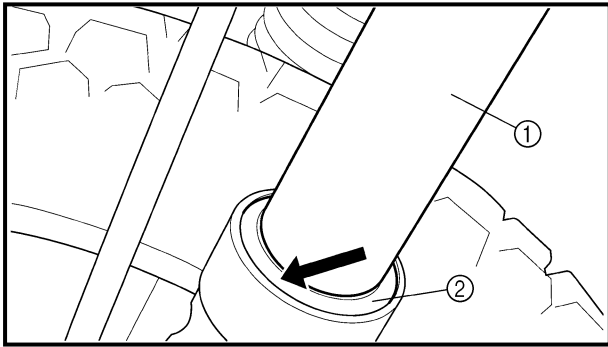

3. Check:

- Inner tube ①
Scratch/damage → Replace.
- Dust seal ②
- Oil seal
Excessive oil leakage → Replace.

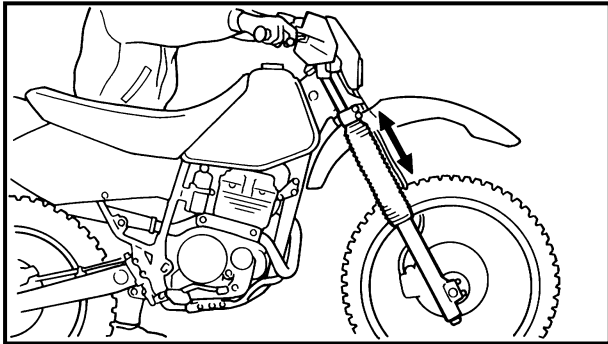

4. Hold the motorcycle on upright position and apply the front brake.

5. Check:

- Operation
Pump the front fork up and down for several times.
Unsmooth operation → Repair.
Refer to "FRONT FORK" in CHAPTER 6.

6. Install:

- Fork boots
- Band
Refer to "FRONT FORK" in CHAPTER 6.

CAUTION

Always use a new band.

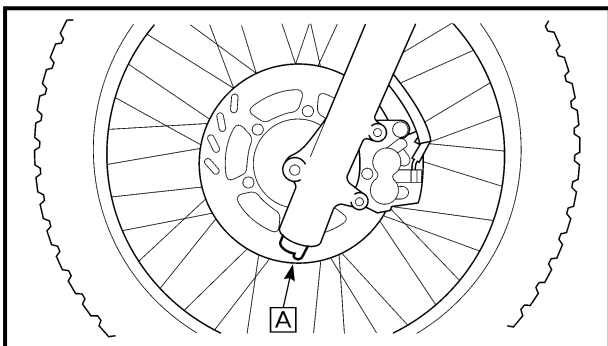

NB1A1003

FRONT FORK ADJUSTMENT

⚠ WARNING

- Always adjust each fork to the same setting. Uneven adjustment can cause poor handling and loss of stability.
- Securely support the motorcycle so there is no danger of it falling over.

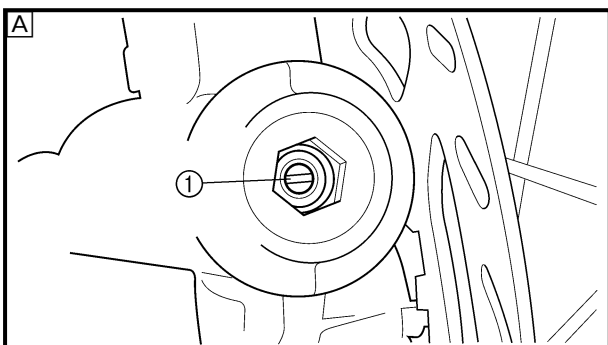

Compression damping

1. Adjust:

- Compression damping
Turn the adjuster ① in or out.

Turning in → Compression damping is harder.

Turning out → Compression damping is softer.

Adjuster position:
Standard: 13 clicks out
Minimum: 20 clicks out
Maximum: 1 click out from full turn in

- Always keep the adjustment level equal on both forks.
- Never attempt to turn the adjuster beyond the maximum or minimum setting.

Spring preload adjusting air valve

1. Elevate the front wheel by placing a suitable stand under the frame and engine.

NOTE: When checking and adjusting the air pressure, there should be no weight on the front end of the motorcycle.

2. Remove:

- Air valve caps ①

3. Adjust:

- Air pressure

Adjustment steps:

- Check the air pressure with an air pressure gauge.

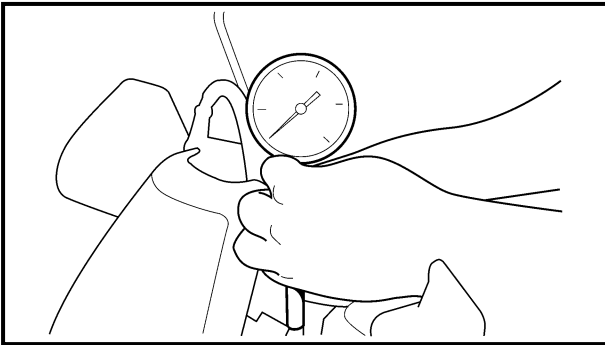
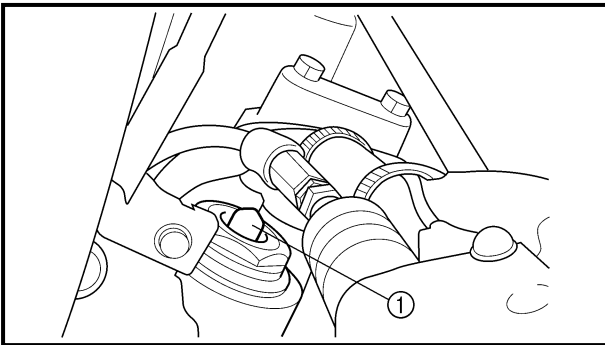

Stiffer → Increase the air pressure.
(Use an air pump or pressurized air supply.)
Softer → Decrease the air pressure.
(Release the air by pushing the valve.)

Standard air pressure:
0 kPa (0 kg/cm², 0 psi)
Maximum air pressure:
40 kPa (0.4 kg/cm², 5.7 psi)

Never exceed the maximum pressure as oil seal damage may occur.

⚠ WARNING

The difference between the left and right tubes should be 10 kPa (0.1 kg/cm², 1.4 psi) or less.

- 4.Install:
- Air valve caps

NB533012

REAR SHOCK ABSORBER ADJUSTMENT

⚠ WARNING

Securely support the motorcycle so there is no danger of it falling over.

1.Remove:

- Side cover (right)
- Battery box
- Seat

Refer to "REAR SHOCK ABSORBER AND SWINGARM" in CHAPTER 6.

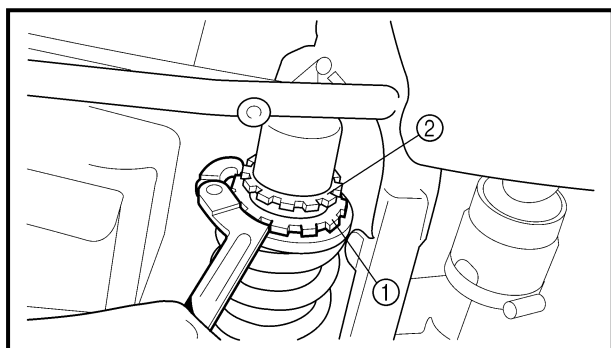

Spring preload

1.Adjust:

- Spring preload
Turn the adjuster ① in or out.

Adjustment steps:

Spring preload

- Loosen the locknut ② using the ring nut wrench.



**Ring nut wrench:
P/N. 90890-01443**

- Turn the adjuster ① in or out.

Turning in → Spring preload is increased.

Turning out → Spring preload is decreased.

REAR SHOCK ABSORBER ADJUSTMENT

**CHK
ADJ**

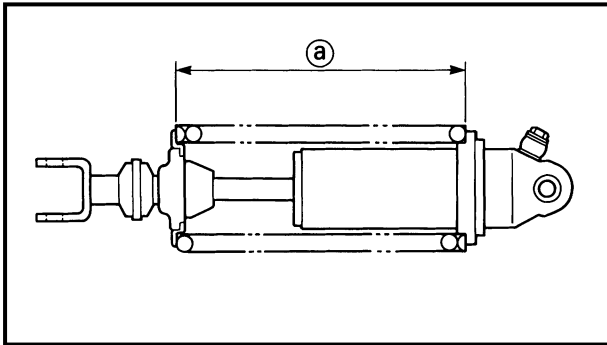

Measurement length (a):

Standard:
228 mm (9.0 in)

Minimum:
224 mm (8.8 in)

Maximum:
236 mm (9.3 in)

Never attempt to turn the adjuster beyond the maximum or minimum setting.

- Tighten the locknut.



Locknut:
70 Nm (7.0 m • kg, 50 ft • lb)

CAU

Always tighten the locknut against the spring adjuster and torque the locknut to specification.

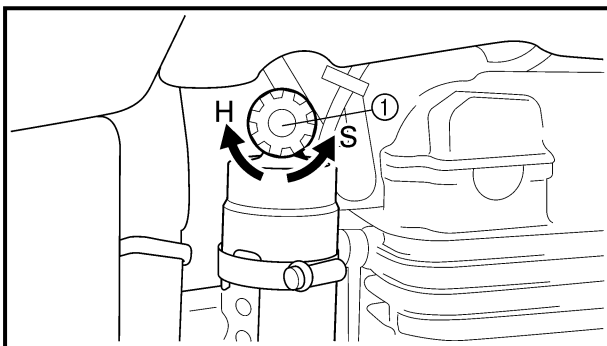

Compression damping

1.Adjust:

- Compression damping
Turn the adjuster ① to in or out.

Turning in → Compression damping is harder.

Turning out → Compression damping is softer.

Adjuster position:

Standard: 11 clicks in

Minimum: 5 click in from full turn out

Maximum: 15 clicks in

Never turn the adjuster beyond the maximum or minimum setting.

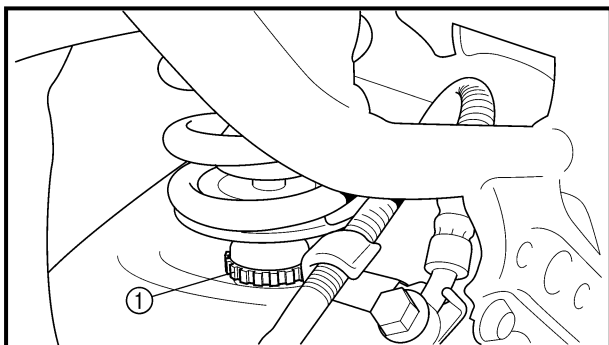

Rebound damping

1.Adjust:

- Rebound damping
Turn the adjuster ① in or out.

Turning in → Rebound damping is harder.

Turning out → Rebound damping is softer.

Adjuster position:

Standard: 8 clicks out

Minimum: 16 clicks out

Maximum: 1 click out from full turn in.

NB2A3013

TIRE INSPECTION

1.Measure:

- Tire pressure
Out of specification → Adjust.

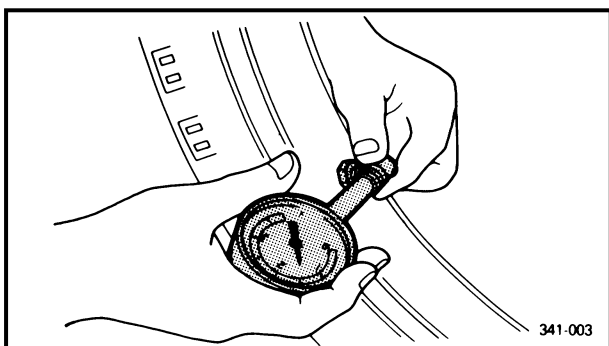

⚠ WARNING

- Tire inflation pressure should be checked and adjusted when the temperature of the tire equals the ambient air temperature. Tire inflation pressure must be adjusted according to total weight of cargo, rider, passenger, and accessories (fairing, saddlebags, etc. if approved for this model), and vehicle speed.
- Proper loading of your motorcycle is important for the handling, braking, and other performance and safety characteristics of your motorcycle. Do not carry loosely packed items that can shift. Securely pack your heaviest items close to the center of the motorcycle, and distribute the weight evenly from side to side. Properly adjust the suspension for your load, and check the condition and pressure of your tires. **NEVER OVERLOAD YOUR MOTORCYCLE.** Make sure the total weight of the cargo, rider, passenger, and accessories (fairing, saddlebags, etc. if approved for this model) does not exceed the maximum load of the motorcycle. Operation of an overloaded motorcycle could cause tire damage, an accident, or even injury.



Basic weight: With oil and full fuel tank	124 kg (273 lb)
Maximum load- except motorcycle*	90 kg (198 lb)

Cold tire pres- sure	Front	Rear
Off-road riding*	100 kPa (1 kg/cm², 14.5 psi)	100 kPa (1 kg/cm², 14.5 psi)

* Load is the total weight of rider, and accessories.

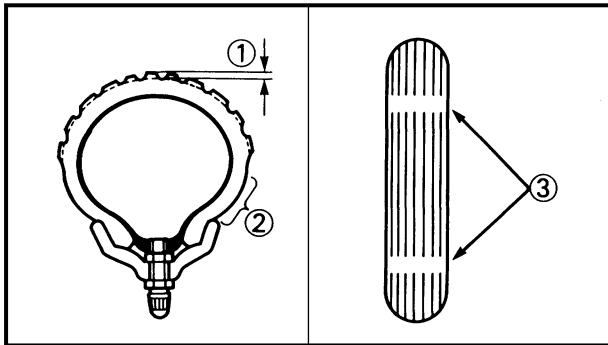

2. Inspect:

- Tire surfaces
Wear/damage → Replace.

	Minimum tire tread depth (front and rear): 0.8 mm (0.03 in)
---	--

- ① Tread depth
- ② Side wall
- ③ Wear indicator

⚠ WARNING

- It is dangerous to ride with a worn-out tire. When a tire tread begins to show lines, replace the tire immediately.
- Patching a punctured tube is not recommended. If it is absolutely necessary to do so, use great care and replace the tube as soon as possible with a good quality replacement.
- Do not attempt to use tubeless tires on a wheel designed for tube type tires only. Tire failure and personal injury may result from sudden deflation.

Tube type wheel → Tube type tire only.
Tubeless type wheel → Tube type or tubeless tire.

- Be sure to install the correct tube when using tube type tires.
- After extensive tests, the tires mentioned below have been approved by Yamaha motor Co., Ltd. for this model. No guarantee for handling characteristics can be given if tire combinations other than what is approved are used on this motorcycle. The front and rear tires should be of the same manufacture and design.

Front:

Manufacturer	Size	Type
DUNLOP	80/100-21 51M	Tube

Rear:

Manufacturer	Size	Type
DUNLOP	100/100-18 59M	Tube

NOTE:

- For tires with the "DRIVE" mark ①:
- Install the wheel with the "DRIVE" mark pointing in the rotating direction.
 - Align the light point mark (yellow) ② with the valve installation point.

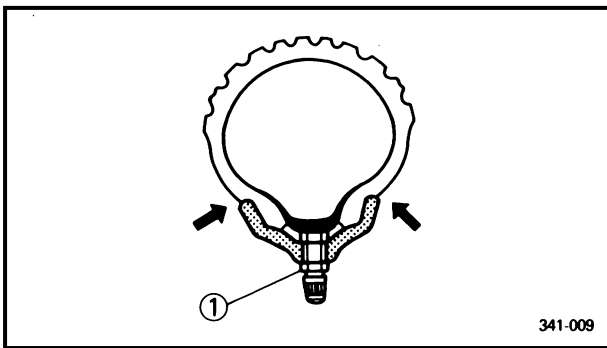
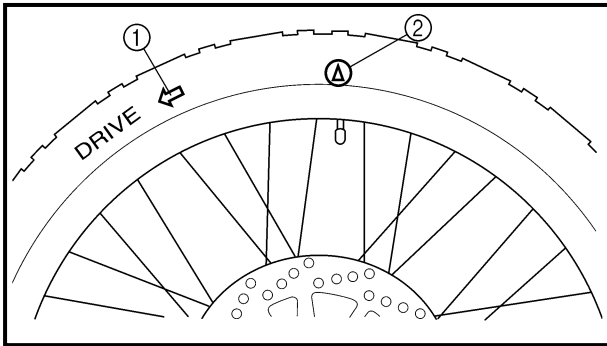

⚠ WARNING

- After mounting a tire, ride conservatively to allow proper tire to rim seating. Failure to do so may cause an accident resulting in motorcycle damage and possible operator injury.
- After a tire repair or replacement, be sure to torque tighten the valve stem locknut ① to specification.

	<p>Valve stem locknut ①: 1.5 Nm (0.15 m · kg, 1.1 ft · lb)</p>
---	--

NA2A3016

WHEEL INSPECTION

1. Inspect:

- Wheels
Damage/bends → Replace.

NOTE: _____
Always balance the wheel when a tire or wheel has been changed or replaced.

⚠ WARNING _____

Never attempt even small repairs to the wheel.

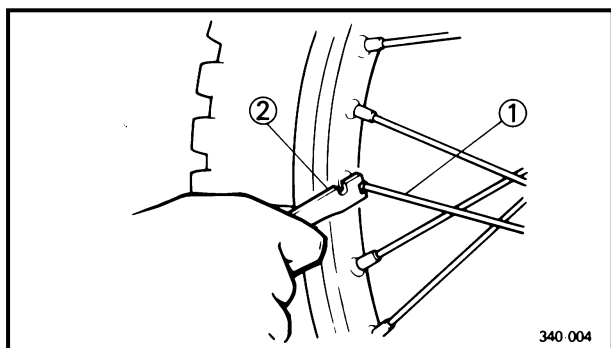

NB2A3017

SPOKES INSPECTION AND TIGHTENING

1. Inspect:

- Spokes ①
Bend/damage → Replace.
Loose spoke → Retighten.

2. Tighten:

- Spokes
② Spoke wrench

NOTE: _____
Be sure to retighten these spokes before and after break-in.



Nipple:
3 Nm (0.3 m • kg, 2.2 ft • lb)

CABLE INSPECTION AND LUBRICATION

⚠ WARNING _____

A damaged cable sheath may cause corrosion and interfere with the cable movement. An unsafe condition may result, so replace such a damaged cable as soon as possible.

1. Inspect:
 - Cable sheath
Damage → Replace.
2. Check:
 - Cable operation
Unsmooth operation → Lubricate.

	Recommended lubricant: SAE 10W30 motor oil
---	---

NOTE: _____
Hold cable end high and apply several drops of lubricant to cable.

NB3A3019
LEVER AND PEDAL LUBRICATION
Lubricate the lever and pedal at their pivoting points.

	Recommended lubricant: SAE 10W30 motor oil
---	---

NB3A5000
SIDESTAND LUBRICATION
Lubricate the sidestand at pivoting points.

	Recommended lubricant: SAE 10W30 motor oil
---	---



ELECTRICAL BATTERY INSPECTION

NOTE:

Since the MF battery is of a sealed-type construction, it is impossible to measure the specific gravity of the electrolyte in order to check the state of charge in the battery. Therefore, to check the state of charge in the battery, voltage must be measured at the battery terminals.

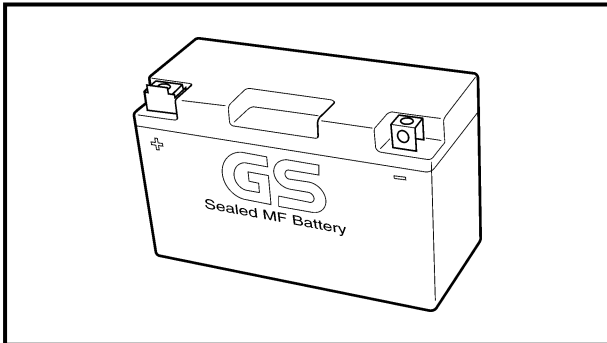

CAUTION

CHARGING METHOD

- This battery is of the sealed type. Never remove sealing caps even when charging. With the sealing caps removed, the balance will not be maintained, and battery performance will lower gradually.
- Never add water. If distilled water is added, chemical reaction in the battery will not proceed in the normal way, thus making it impossible for the battery to operate regularly.
- The charging time, charging current and charging voltage for the MF battery are different from those of general type batteries.
The MF battery should be charged as instructed in the "Charging method". Should the battery be overcharged, the electrolyte level will lower extremely. Therefore, use special care when charging the battery.
- Avoid using any electrolyte other than specified. The specific gravity of the MF battery electrolyte is 1.32 at 20 °C (68 °F). (The specific gravity of the general type battery electrolyte is 1.28.) If the electrolyte whose specific gravity is less than 1.32, the sulfuric acid will decrease and thus low battery performance will result. Should any electrolyte, whose specific gravity is 1.32 or more, be used, the battery plates will corrode and battery life will shorten.



⚠ WARNING

Battery electrolyte is dangerous; it contains sulfuric acid and therefore is poisonous and highly caustic.

Always follow these preventive measures:

- Avoid bodily contact with electrolyte as it can cause severe burns or permanent eye injury.
- Wear protective eye gear when handling or working near batteries.
- Antidote (EXTERNAL):
- SKIN-Flush with water.
- EYES-Flush with water for 15 minutes and get immediate medical attention.
- Antidote (INTERNAL):
- Drink large quantities of water or milk follow with milk of magnesia, beaten egg, or vegetable oil. Get immediate medical attention.
- Batteries also generate explosive hydrogen gas, therefore you should always follow these preventive measures:
- Charge batteries in a well-ventilated area.
- Keep batteries away from fire, sparks, or open flames (e.g., welding equipment, lighted cigarettes, etc.)
- DO NOT SMOKE when charging or handling batteries.

KEEP BATTERIES AND ELECTROLYTE OUT OF REACH OF CHILDREN.

1.Remove:

- Side cover (right)
Refer to "SEAT, FUEL TANK AND COVERS".

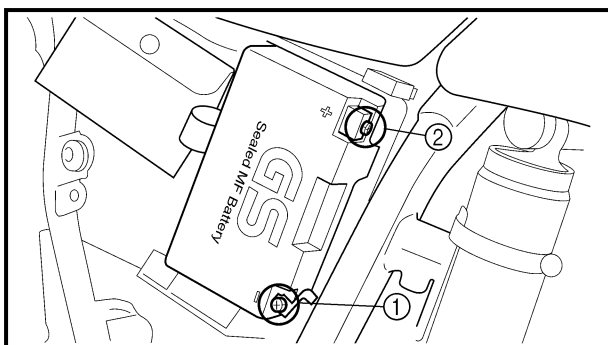

2.Disconnect:

- Battery leads

Disconnect the negative lead ① first and then disconnect the positive lead ②.

3.Remove:

- Battery

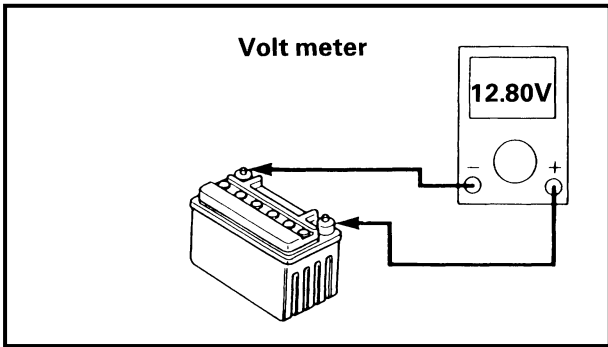

4. Check:

- Battery condition

Battery condition checking steps:

- Connect a digital volt meter to the battery terminals.

Tester (+) lead → Battery (+) terminal.
Tester (-) lead → Battery (-) terminal.

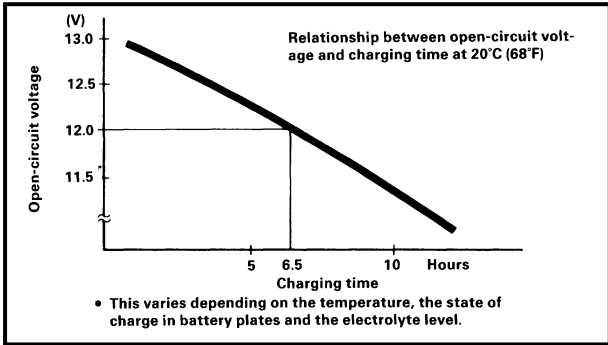

NOTE:

The state of a discharged MF battery can be checked by measuring the open-circuit voltage (the voltage measured with the positive terminal being disconnected).

Open-circuit voltage	Charging time
12.8 V or more	No charging is necessary.

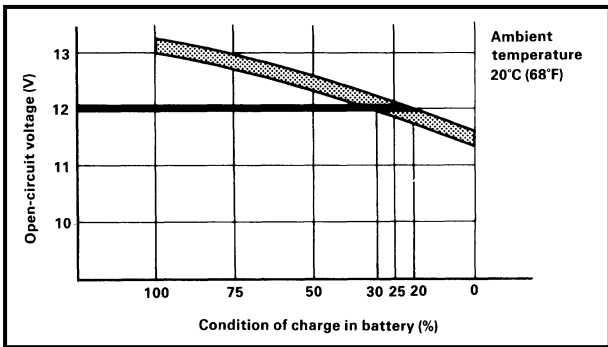

- Check the battery condition using the given figures.

Example:

Open-circuit voltage = 12.0 V

Charging time = 6.5 hours

Condition of charge in battery = 20 ~ 30 %

5. Charging method of MF batteries.

- If it is impossible to set the standard charging current, be sure not to over charge.
- When charging the battery, be sure to remove it from the machine. (If charging has to be done with the battery mounted on the machine for some reason, be sure to disconnect the wire at the negative terminal.)
- Never remove the sealing plug from the MF battery.

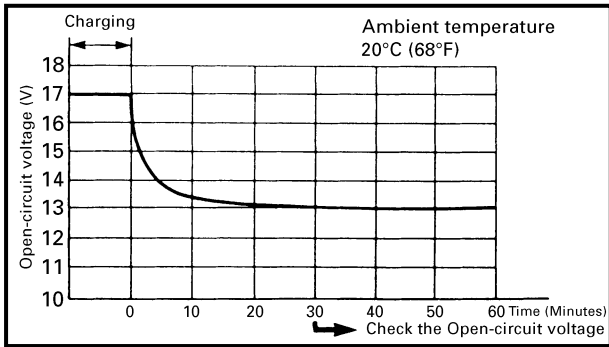

- Use special care so that charging clips are in full contact with the terminal and that they are not shorted. (A corroded clip of the charger may cause the battery to generate heat at the contact area. A weak clip spring may cause sparks.)
- Before removing the clips from the battery terminals, be sure to turn off the power switch of the charger.
- Change in the open-circuit voltage of the MF battery after being charged is shown in the figure. The open-circuit voltage is stabilized 30 minutes after charging has been completed.
Therefore, to check the condition of the battery, measure the open-circuit voltage 30 minutes after charging has been completed.

Charging method using a variable-current (voltage) type charger

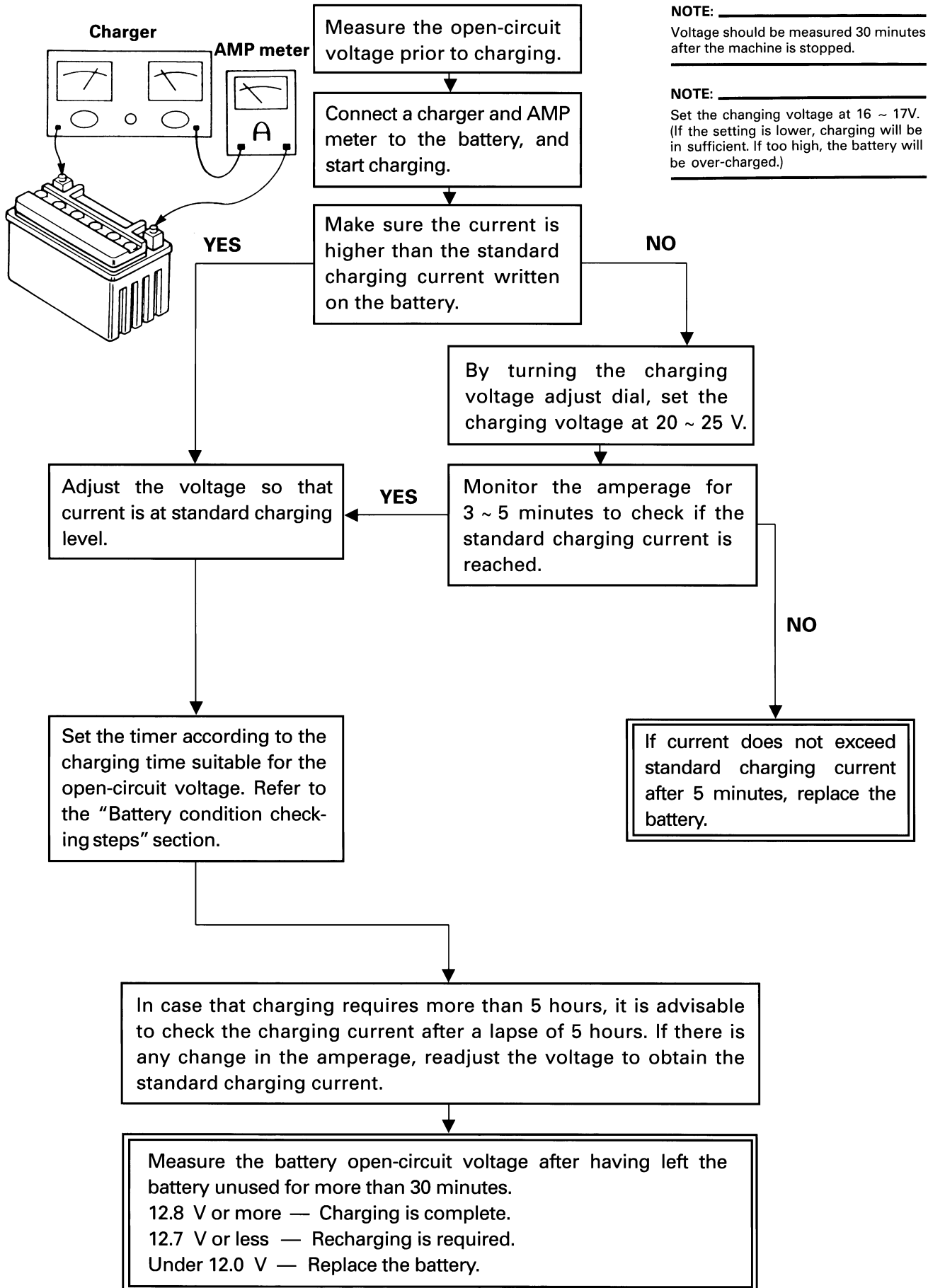

Charging method using a constant-voltage type charger

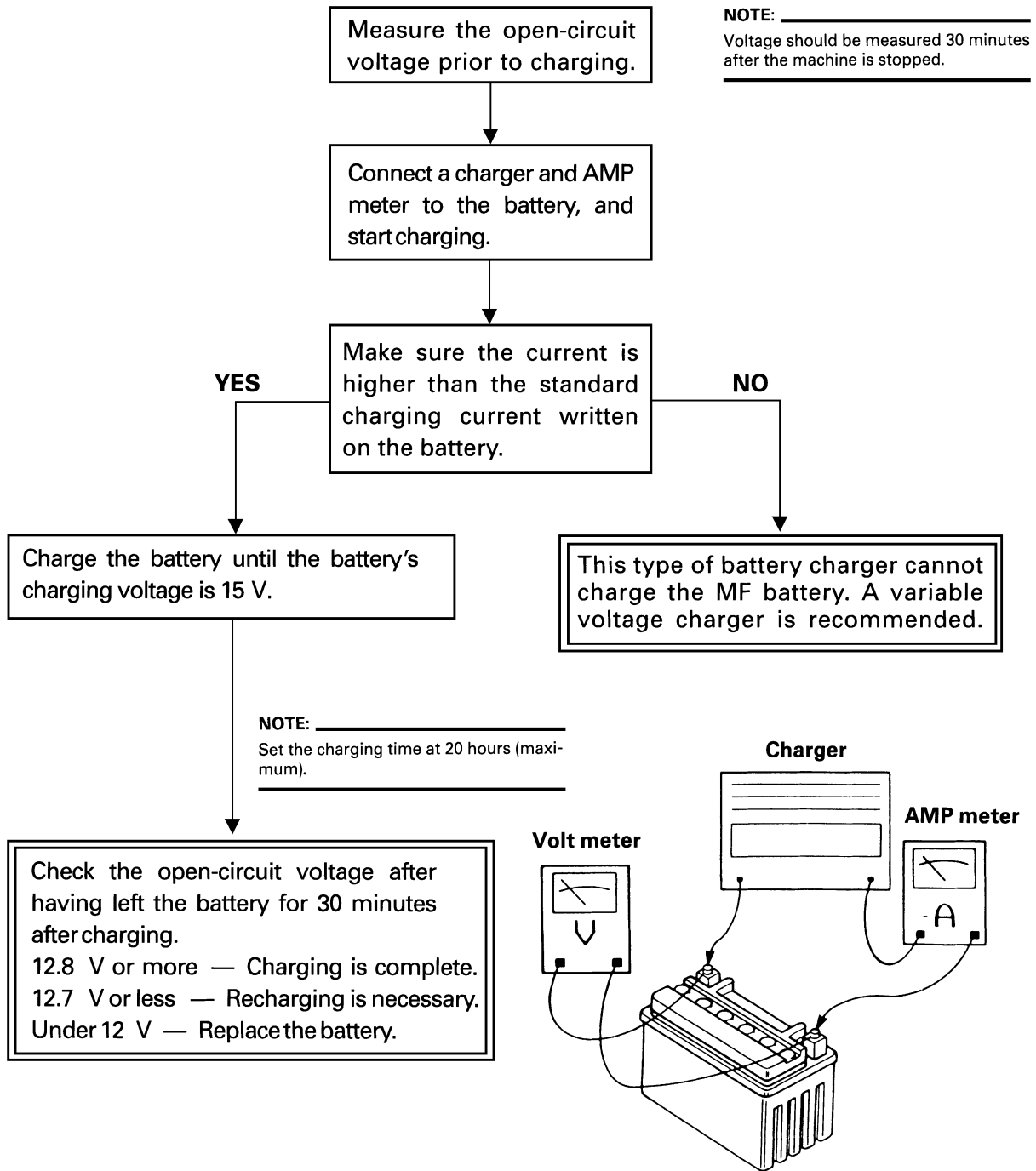

Charging method using a constant-current type charger

This type of charger cannot charge the MF battery.



6. Inspect:

- Battery terminal
Dirty terminal → Clean with wire brush.
Poor connection → Correct.

NOTE:

After cleaning the terminals, apply grease lightly to the terminals.

7. Install:

- Battery

8. Connect:

- Battery leads

CAU

Connect the positive lead first and then connect the negative lead.

9. Install:

- Side cover (right)

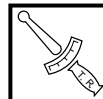

**Bolt (side cover):
7 Nm (0.7 m · kg, 5.1 ft · lb)**

NB302001

FUSE INSPECTION

Don't forget to turn off the main switch when checking or replacing the fuse. Otherwise, it may cause accidental short-circuiting.

1. Remove:

- Side cover (right)
Refer to "SEAT, FUEL TANK AND COVERS".

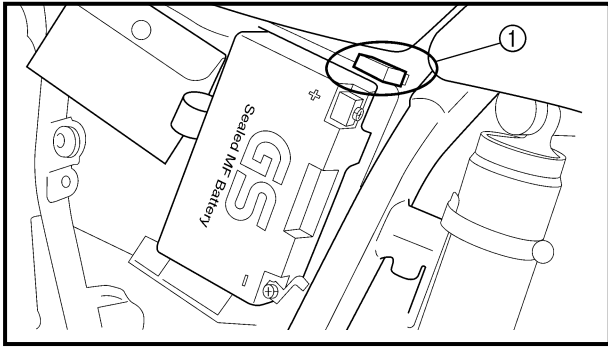

- 2.Remove:
- Fuse ①

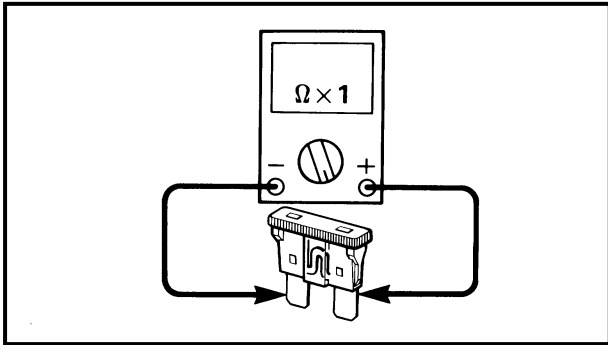

- 3.Inspect:
- Fuse

Inspection steps:

- Connect the pocket tester to the fuse and check it for continuity.

NOTE: _____
Set the tester selector to "Ω × 1" position.

	Pocket tester: P/N. YU-03112
---	--

- If the tester indicates ∞, the fuse is blown and needs to be replaced.

- 4.Replace:

- Blown fuse

Blown fuse replacement steps:

- Turn off the ignition and the circuit.
- Install a new fuse of proper amperage.

	Fuse: 15 A × 1 pc.
---	------------------------------

- Turn on the switches to verify operation of electrical device.
- If the fuse blows immediately again, check the circuit in question.

⚠ WARNING _____

Never use a fuse with a rating other than specified, or other material in place of a fuse. An improper fuse may cause damage to the electrical system and possible cause a fire, or the lighting and/or ignition may cease to function.

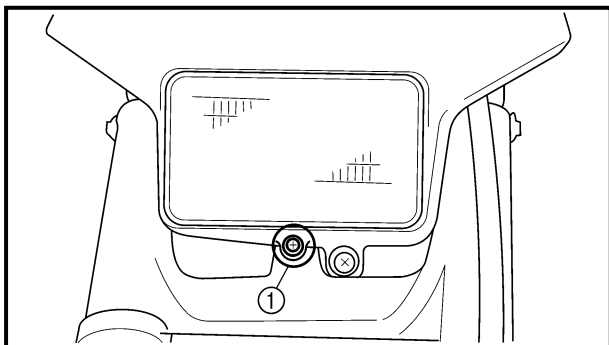

HEADLIGHT BEAM ADJUSTMENT

1.Adjust:

- Headlight beam (vertical)

To raise the beam	Turn adjusting screw ① counterclockwise.
To lower the beam	Turn adjusting screw ① clockwise.

HEADLIGHT BULB REPLACEMENT

1.Remove:

- Cover (headlight)

2.Disconnect:

- Headlight leads

⚠ WARNING

Keep flammable products and your hands away from the bulb while it is on, it will be hot. Do not touch the bulb until it cools down.

3.Install:

- Bulb (new)

CAU

Avoid touching glass part of bulb. Also keep it free from oil otherwise, transparency of glass, bulb life and luminous flux will be adversely affected. If oil gets on bulb, clean it with a cloth moistened thoroughly with alcohol or lacquer thinner.

4.Install:

- Bulb cover
- Headlight leads

5.Install:

- Cover (headlight)



NB241000

ENGINE OVERHAUL

ENGINE REMOVAL

NOTE:

It is not necessary to remove the engine in order to remove the following components.

- Cylinder head
- Cylinder
- Clutch
- Oil pump
- CDI magneto

SEAT, FUEL TANK AND COVERS

1.Remove:

- Side covers
- Seat
- Fuel tank

Refer to "SEAT, FUEL TANK AND COVERS" in CHAPTER 3.

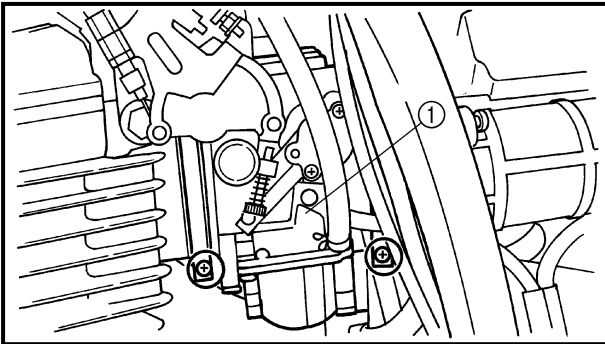

CARBURETOR

1.Remove:

- Carburetor ①

Refer to "CARBURETOR" in CHAPTER 5.

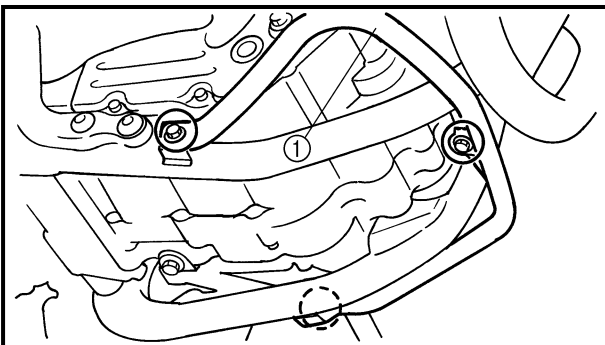

ENGINE GUARD

1.Remove:

- Engine guard ①

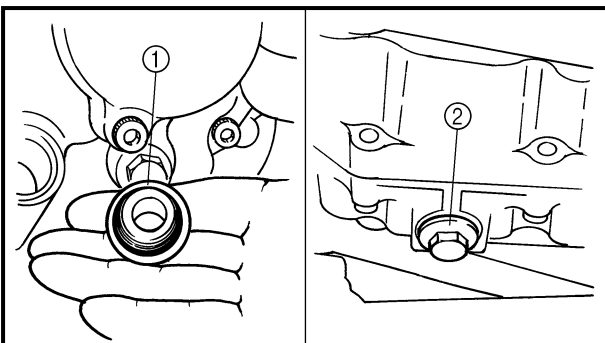

ENGINE OIL

1.Drain:

- Oil filler cap ①
- Drain plug ②

Refer to "ENGINE OIL REPLACEMENT" in CHAPTER 3.

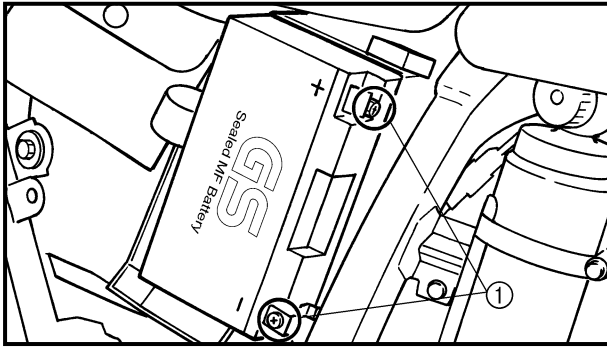

NB241003

BATTERY

1.Remove:

- Battery ①

Refer to "BATTERY INSPECTION" in CHAPTER 3.

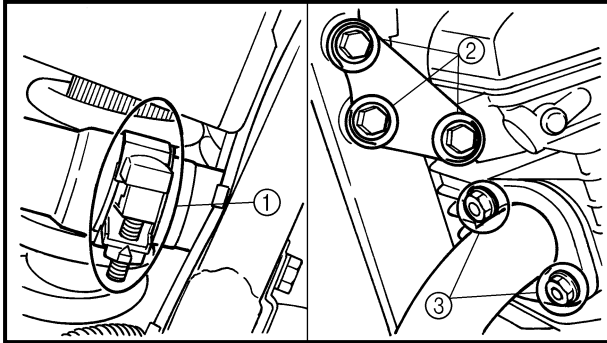
**EXHAUST PIPE**

1.Loosen:

- Bolt ① (clamp)

2.Remove:

- Mounting bolts ② (front-upper)
- Nuts ③ (exhaust pipe)

3.Remove:

- Exhaust pipe

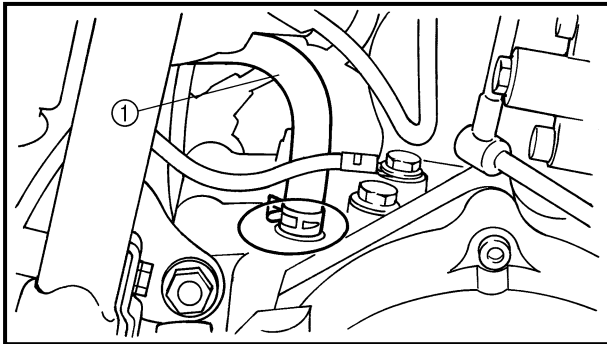
**CRANKCASE BREATHER HOSE**

1.Disconnect:

- Crankcase breather hose ①

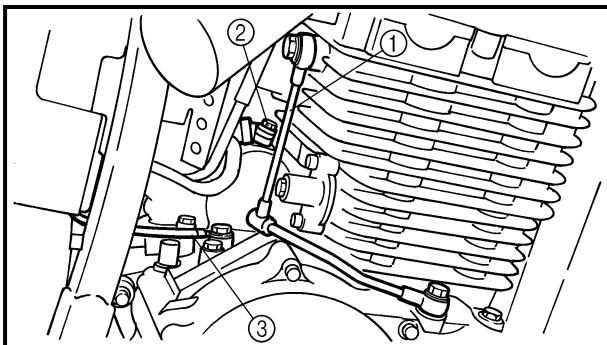
**STARTER MOTOR**

1.Disconnect:

- Gas chamber

Refer to "REAR SHOCK ABSORBER AND SWINGARM" in CHAPTER 6.

2.Remove:

- Oil delivery pipe ①

3.Disconnect:

- Starter motor lead ②
- Ground lead ③

4.Remove:

- Starter motor ④

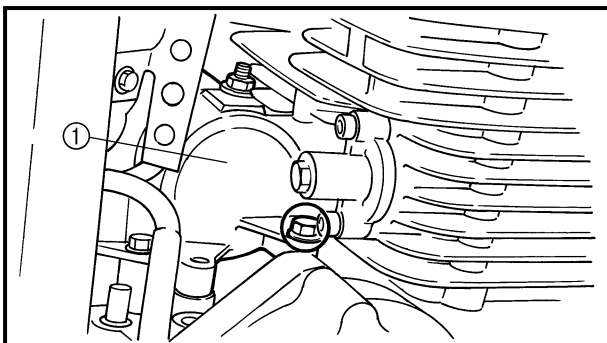

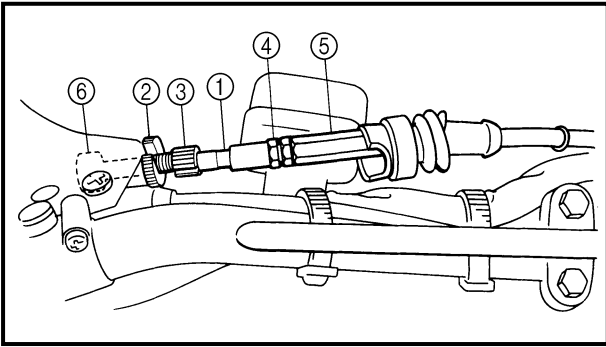

CLUTCH CABLE AND LEADS

1.Remove:

- Clutch cable ①

Removal steps:

- Loosen the locknuts ②, ④.
- Turn the adjuster ③, ⑤ enough to free the clutch cable.
- Unhook the cable end ⑥ from the clutch lever.
- Unhook the cable end from the clutch push lever ⑦.

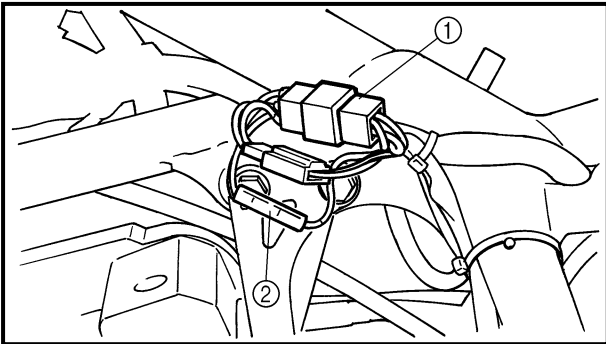
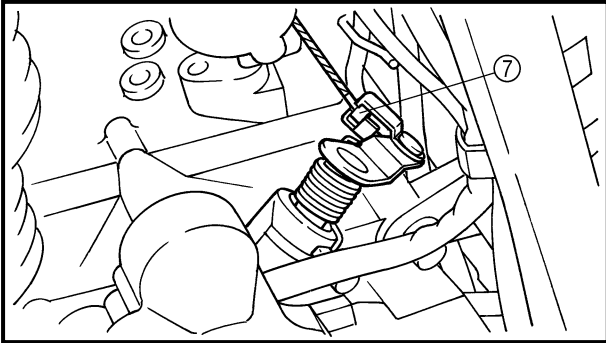

2.Disconnect:

- A.C. magneto leads ①
- Neutral switch lead ②

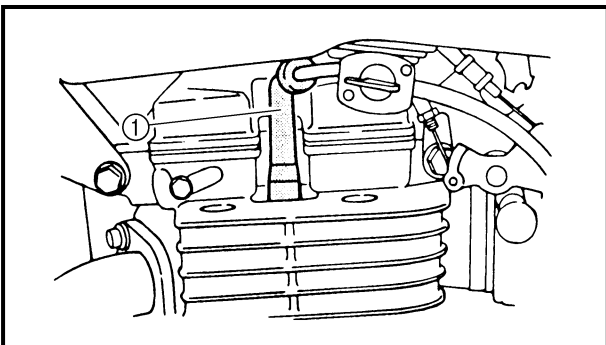

3.Disconnect:

- Spark plug lead ①

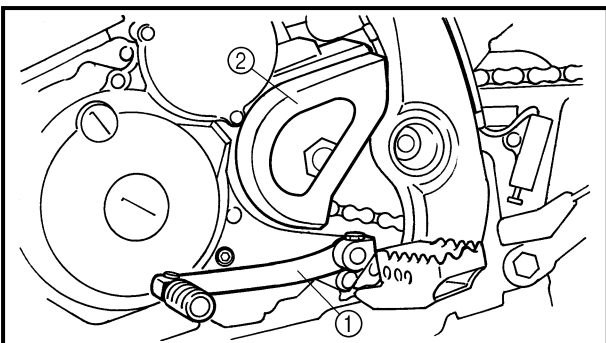

DRIVE SPROCKET

1.Remove:

- Shift pedal ①
- Crankcase cover 3 ②

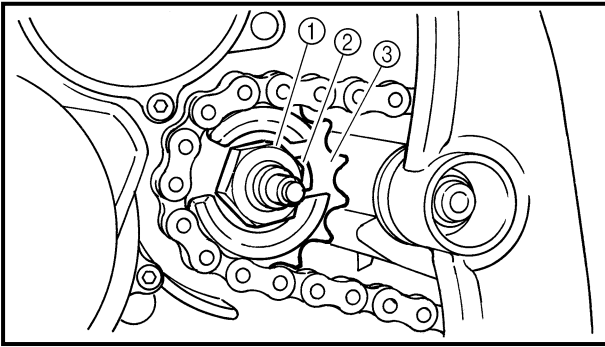

2.Remove:

- Nut ①
- Lock washer ②
- Drive sprocket ③

NOTE:

- Straighten the lock washer tab.
- Loosen the nut while applying the rear brake.
- First remove the drive chain on the rear sprocket side.

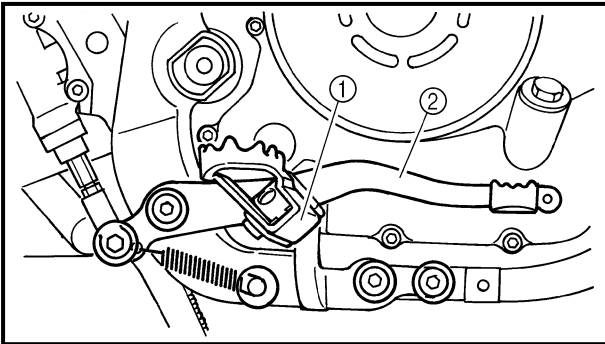
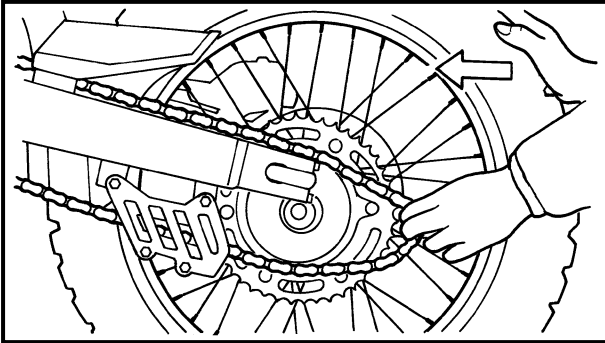

FOOTREST AND BRAKE PEDAL

1.Remove:

- Footrest (right) ①
- Brake pedal ②

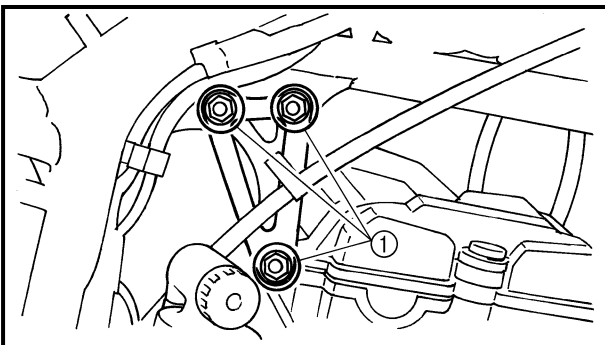

ENGINE REMOVAL

1.Place a suitable stand under the frame and engine

⚠ WARNING

Securely support the motorcycle so there is no danger of it falling over.

2.Remove:

- Mounting bolts ① (rear-upper)

3.Remove:

- Mounting bolt ① (front-lower)
- Mounting bolt ② (rear-center)
- Mounting bolt ③ (rear-lower)
- Engine bracket ④

4.Remove:

- Engine assembly (from right side of motorcycle)

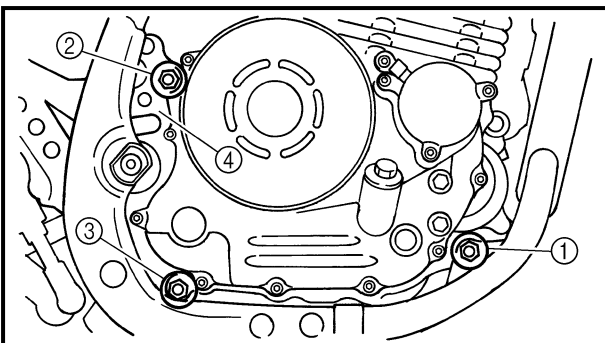

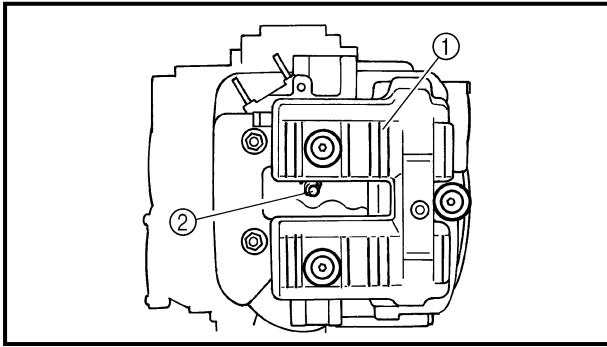

NB342002

ENGINE DISASSEMBLY
CYLINDER HEAD, CAMSHAFTS, CYLINDER
AND PISTON

1.Remove:

- Cylinder head cover ①
- Spark plug ②

2.Remove:

- Plugs (with O-ring)

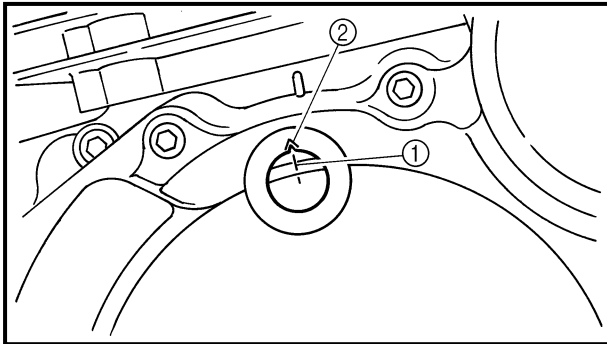

3.Align:

- "T" mark on the rotor
 With the stationary pointer on the crank-
 case cover.

TDC alignment steps:

- Turn the crankshaft clockwise with wrench.
- Align the "T" mark ① on the rotor with the stationary pointer ② on the crankcase cover. When the "T" mark is aligned with the stationary pointer, the piston is at Top Dead Center (TDC).

NOTE:

TDC on compression stroke check:

- Both cam lobes must have a valve clearance when the cam sprockets match mark is aligned with the cylinder head match mark.
- If not, give the crankshaft one counter-clockwise turn to meet above condition.

4.Loosen:

- Cap bolt ① (chain tensioner)

5.Remove:

- Chain tensioner ②

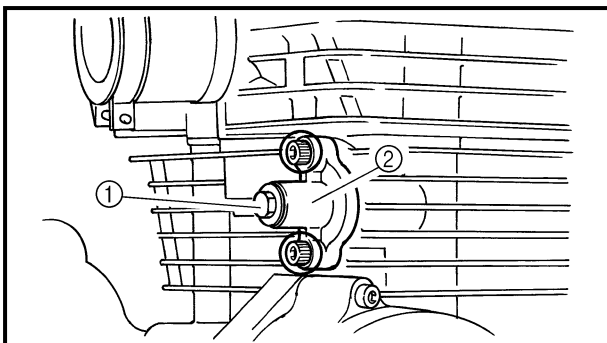
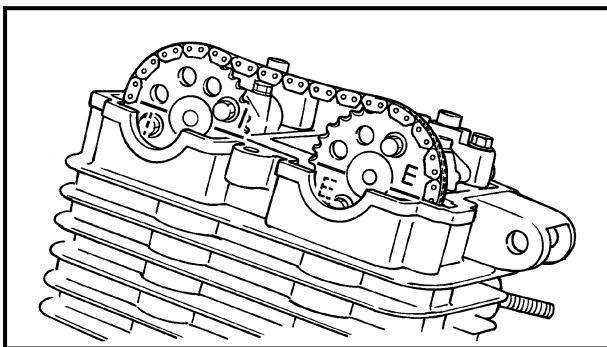

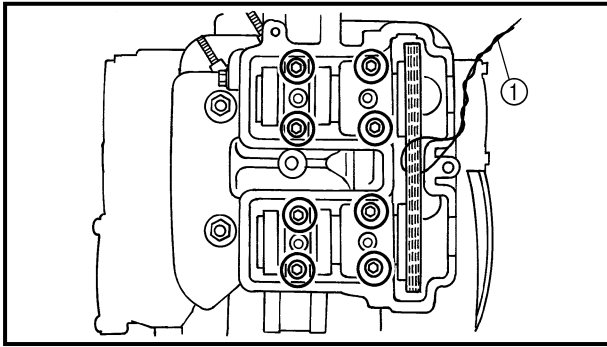

- 6.Remove:
- Camshaft caps

NOTE: _____
 Fasten a safety wire ① to the timing chain to prevent it from falling into the crankcase.

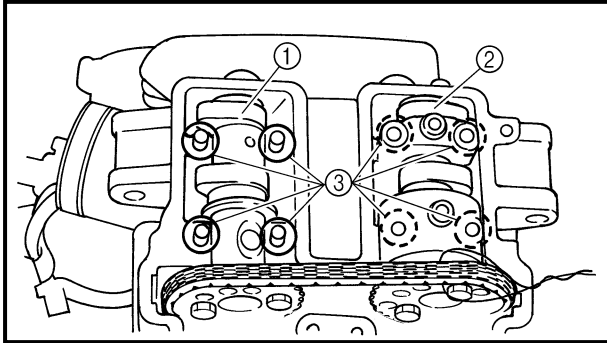

- 7.Remove:
- Camshaft ① (intake)
 - Camshaft ② (exhaust)
 - Dowel pins ③

NOTE: _____
 Remove the camshaft cap bolts in a criss-cross pattern from outside to inside.

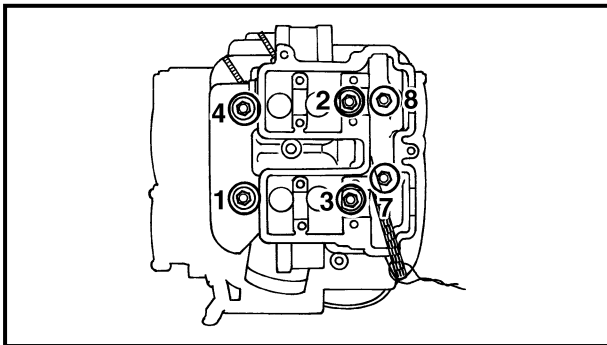

The bolts (camshaft caps) must be removed evenly or damage to the cylinder head, camshaft caps and camshafts will result.

- 8.Remove:
- Bolts
 - Nuts

NOTE: _____

- Loosen the bolts and nuts in the loosening sequence indicated by the numbers.
- Loosen the bolts starting with the highest numbered one.
- Loosen the bolts 1/4 turn each and remove them after all are loosened.

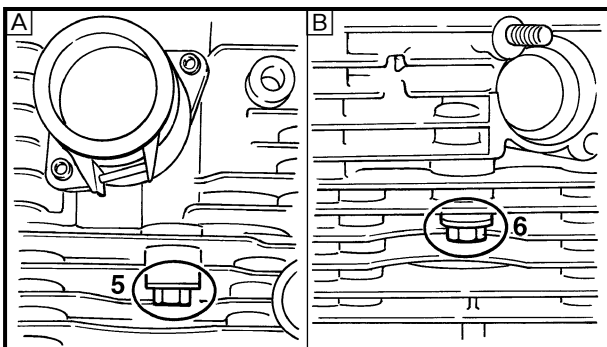

- A** Rear
- B** Front

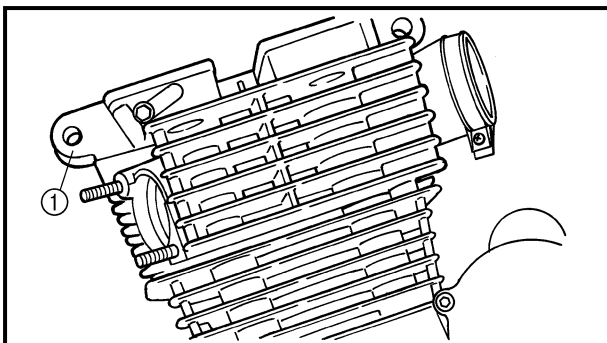

- 9.Remove:
- Cylinder head ①

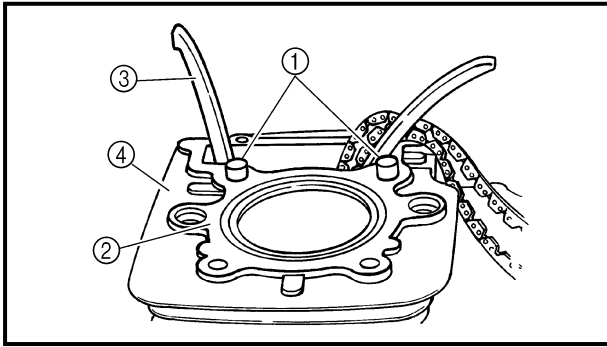

10.Remove:

- Dowel pins ①
- Gasket ② (cylinder head)
- Timing chain guide ③ (exhaust)
- Cylinder ④

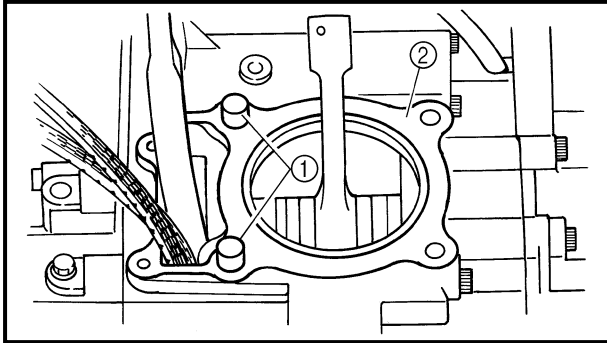

11.Remove:

- Dowel pins ①
- Gasket ② (cylinder)

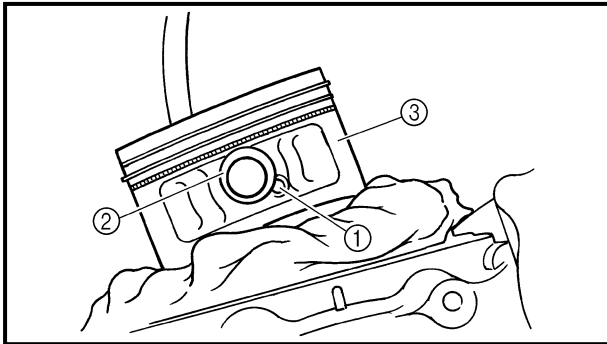

12.Remove:

- Piston pin circlip ①
- Piston pin ②
- Piston ③

NOTE:

- Before removing the piston pin circlip, cover the crankcase with a clean rag to prevent the circlip from falling into the crankcase cavity.
- Before removing the piston pin, deburr the clip groove and pin hole area. If the piston pin groove is deburred and piston pin is still difficult to remove, use the piston pin puller.



Piston pin puller:
P/N. YU-01304

Do not use a hammer to drive the piston pin out.



CLUTCH, OIL PUMP AND BALANCER GEAR

NOTE: _____

With the engine mounted, the clutch and oil pump can be maintained by removing the following parts.

- Footrest (right)
- Brake pedal

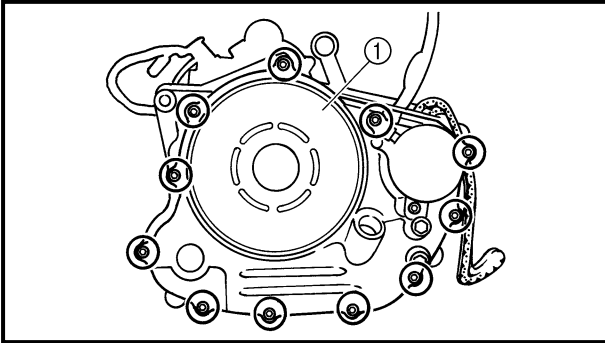

1.Remove:

- Crankcase cover ① (right)

NOTE: _____

Working in a crisscross pattern, loosen the bolts 1/4 turn each. Remove them after all are loosened.

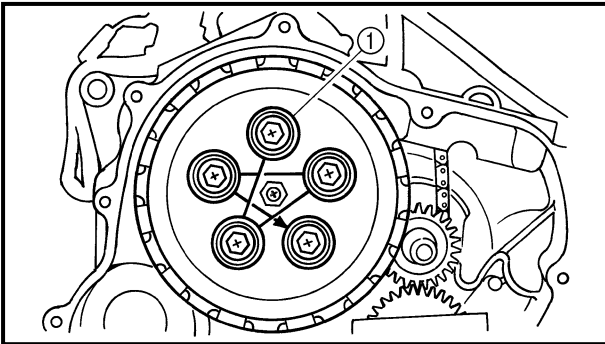

2.Remove:

- Dowel pins
- Gasket (crankcase cover)
- Bolt ①

NOTE: _____

Working in a crisscross pattern, loosen the bolts 1/4 turn each. Remove them after all are loosened.

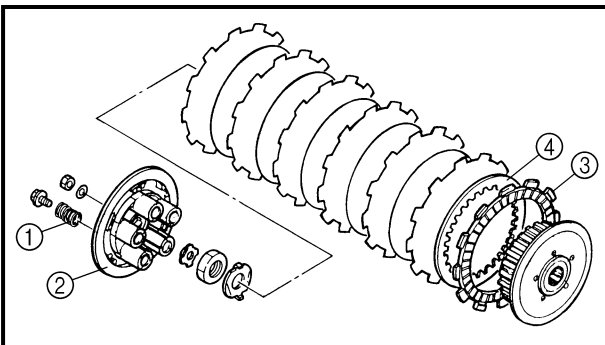

3.Remove:

- Clutch springs ①
- Pressure plate ②
- Friction plates ③
- Clutch plates ④

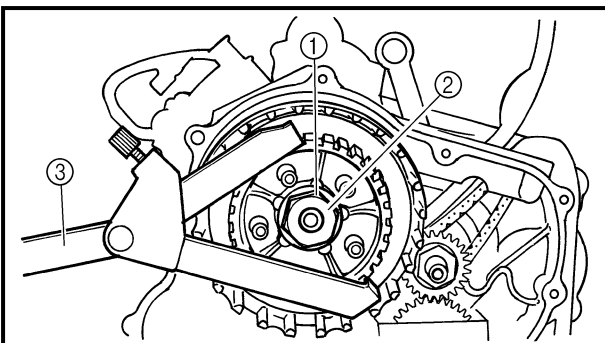

4.Straighten:

- Lock washer tab ①



5. Loosen:
- Nut ② (clutch boss)

NOTE: _____
Loosen the nut (clutch boss) while holding the clutch boss with the universal clutch holder ③.



Universal clutch holder:
P/N. YU-91042

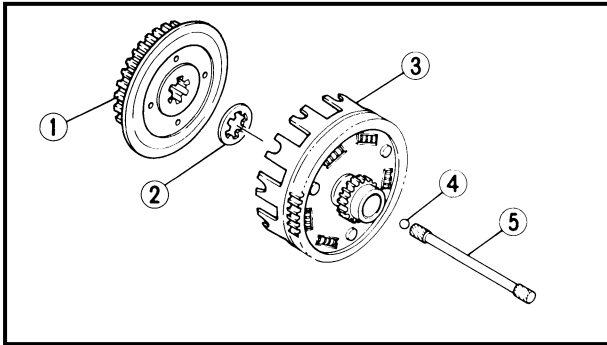

6. Remove:
- Clutch boss ①
 - Thrust plate ②
 - Primary driven gear ③
 - Ball ④
 - Push rod ⑤

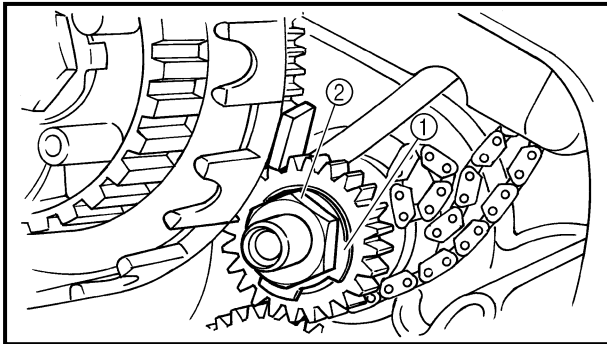

7. Straighten:
- Lock washer tab ①
8. Loosen:
- Nut ② (crankshaft)

NOTE: _____
• Place a folded rag or aluminum plate between the teeth of the primary drive gear and driven gear.
• Take care not to damage the gear teeth.

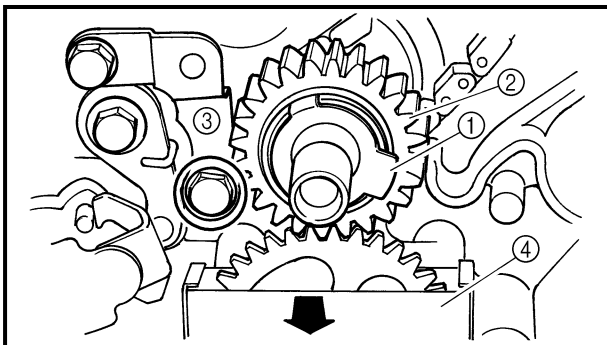

9. Remove:
- Lock washer ①
 - Drive gear ②
 - Timing chain guide ③
 - Oil pump gear cover ④

NOTE: _____
Remove the cover by pulling outward as shown.

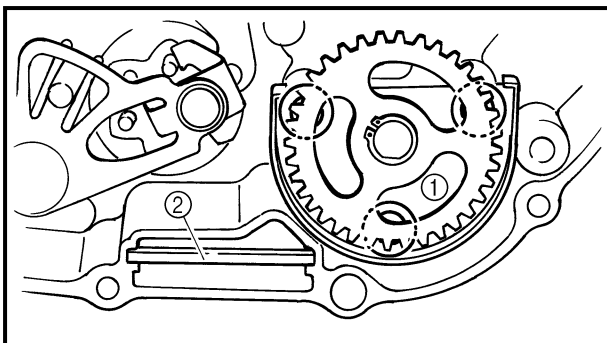

10. Remove:
- Oil pump assembly ①
 - Oil strainer ②

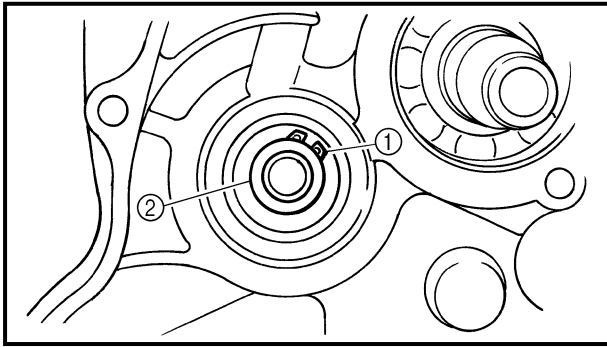

11.Remove:

- Circlip ①
- Collar ②
- Circlip

SHIFT SHAFT

NOTE: _____

With the engine mounted, the shift shaft can be maintained by removing the following parts.

- Footrest (right)
- Brake pedal
- Clutch
- Oil pump

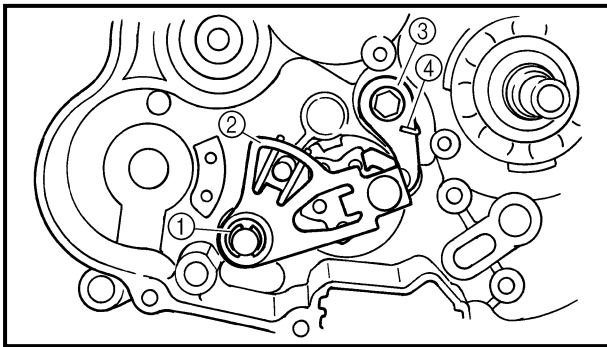

1.Remove:

- Circlip ①
- Shift lever ②
- Stopper lever ③
- Torsion spring ④

ROTOR AND STARTER DRIVES

NOTE: _____

With the engine mounted, the CDI magneto and starter drives can be maintained by removing the following parts.

- Side cover (right)
- Shift pedal
- Fuel tank
- Seat
- Engine guard

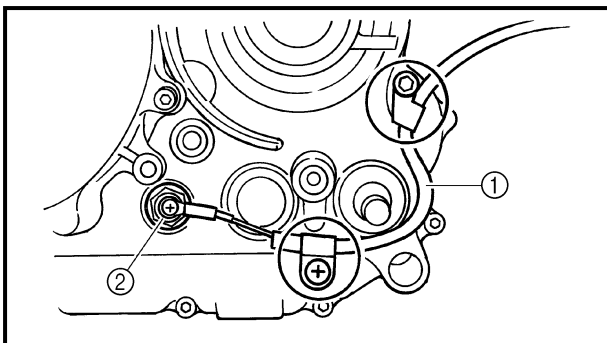

1.Disconnect:

- Neutral switch lead ①
- Neutral switch ②

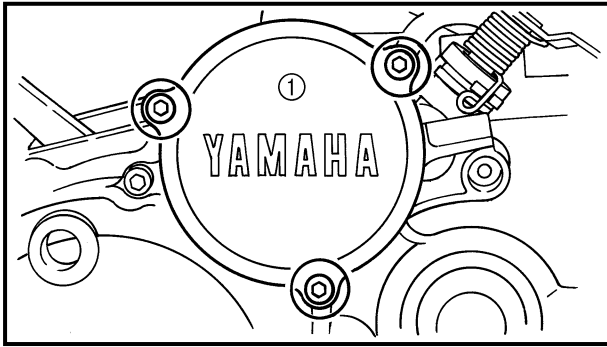

- 2.Remove:
- Generator cover ①

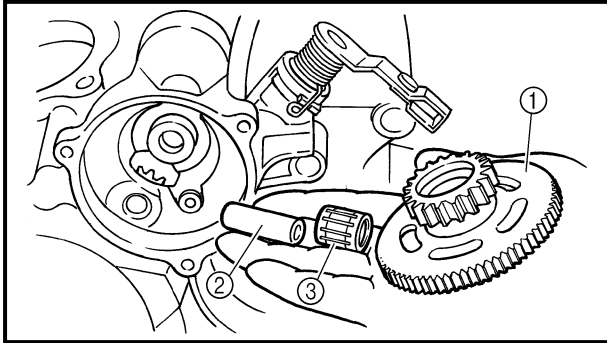

- 3.Remove:
- Starter idle gear 1 ①
 - Shaft ②
 - Bearing ③

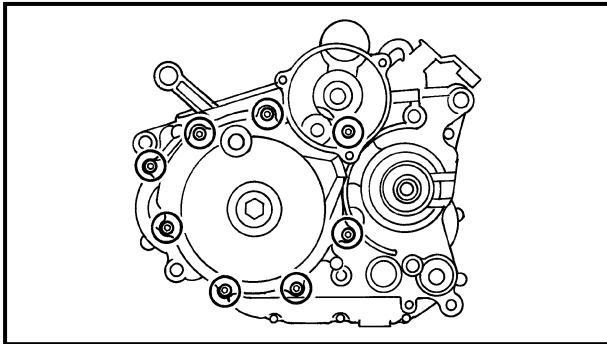

- 4.Remove:
- Crankcase cover 1 (left)

NOTE: _____
Working in a crisscross pattern, loosen the bolts 1/4 turn each. Remove them after all are loosened.

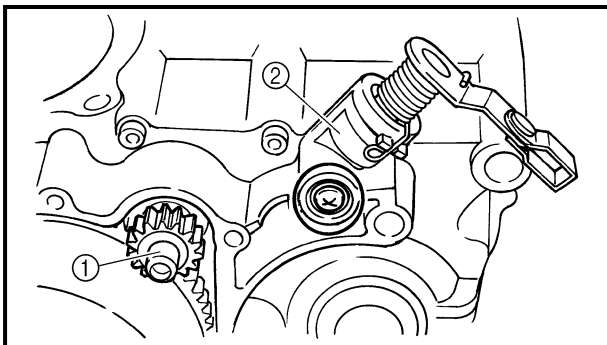

- 5.Remove:
- Starter idle gear 2 ①
 - Push lever assembly ②

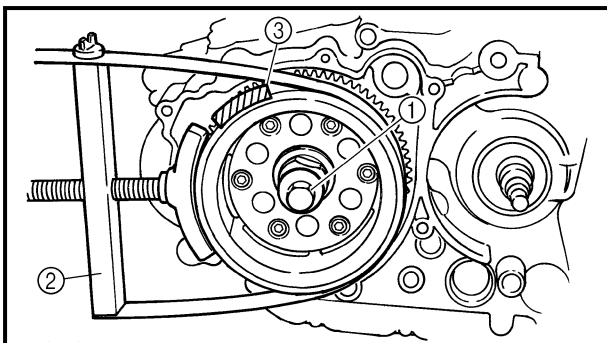

- 6.Remove:
- Bolt ① (rotor)

NOTE: _____
Loosen the bolt (rotor) while holding the rotor with the sheave holder ②.



Sheave holder:
P/N. YS-01880



Do not allow the rotor holder to touch the projection ③ on the rotor.

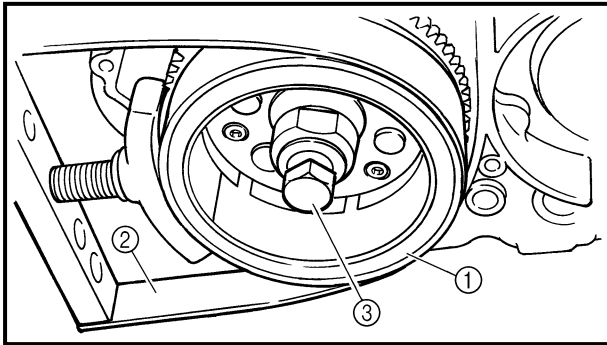

7.Remove:

- Rotor ①
- Use the sheave holder ② and rotor puller ③.



Rotor puller:
P/N. 2K7-85555-00

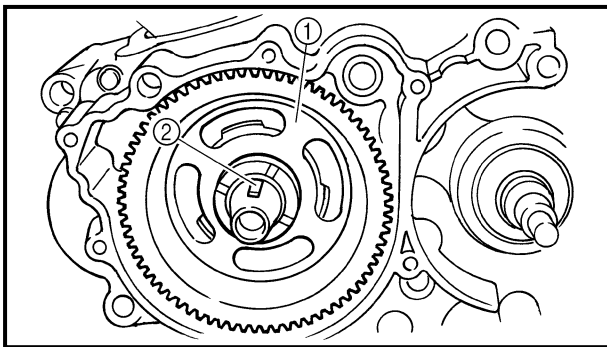

8.Remove:

- Starter wheel gear ①
- Woodruff key ②
- Bearing
- Washer

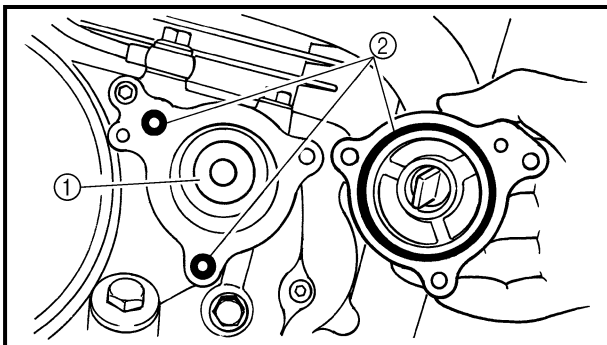

OIL FILTER

1.Remove:

- Oil filter cover

2.Remove:

- Oil filter ①
- O-rings ②

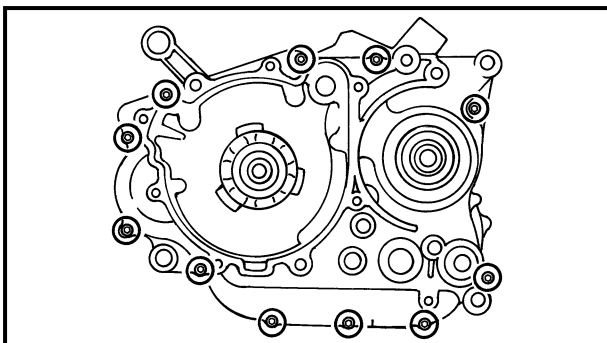

CRANKCASE

1.Remove:

- Bolts (crankcase)

NOTE:

Working in a crisscross pattern, loosen all screws 1/4 turn each. Remove them after all are loosened.

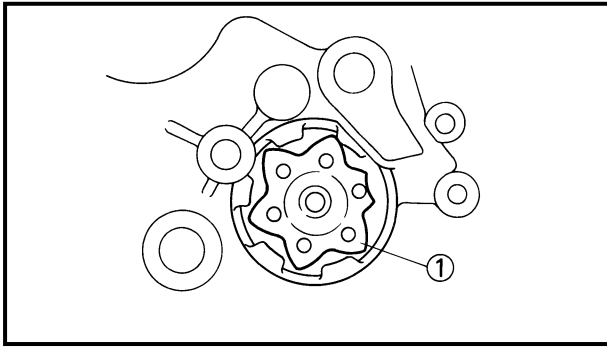

2.Align:

- Shift cam segment ①

NOTE:

Turn the shift cam to the position shown in the figure so that it does not contact the crankcase when separating the crankcase.

3.Remove:

- Crankcase

CA

- The crankcase should be separated from right side.
- Separate the crankcase after checking the shift cam segment and removing the drive axle circlip.
- Do not damage the crankcase mating surfaces.

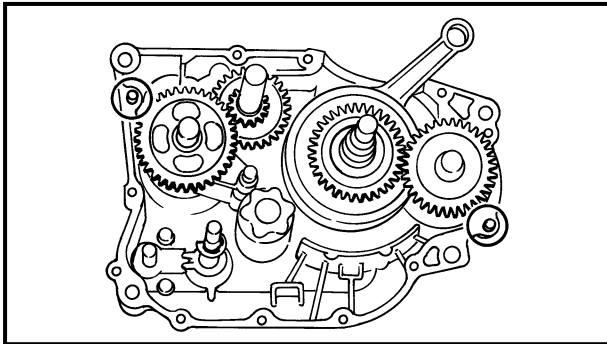

4.Remove:

- Dowel pins

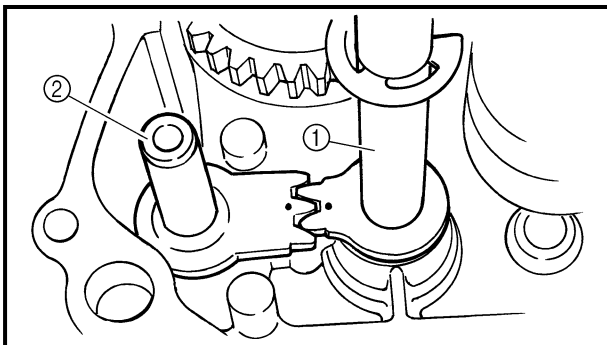

BALANCER, TRANSMISSION AND SHIFTER

1.Remove:

- Shift shaft 1 ①
- Shift shaft 2 ②

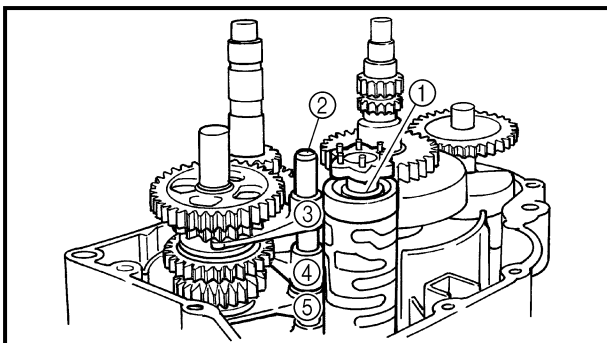

2.Remove:

- Shift cam ①
- Shift fork guide bar ②
- Shift fork R ③
- Shift fork C ④
- Shift fork L ⑤

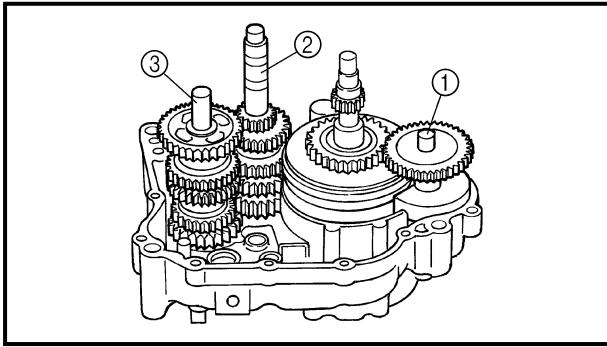

3.Remove:

- Balancer shaft ①
- Main axle shaft ②
- Drive axle shaft ③

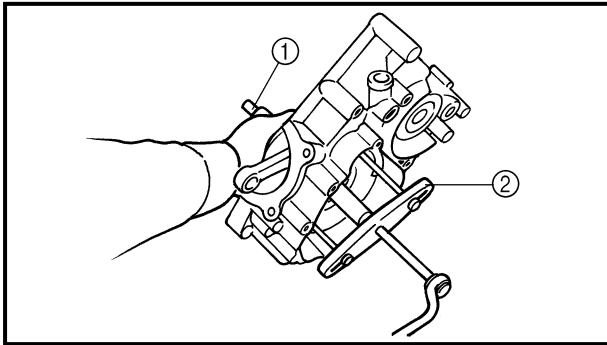

CRANKSHAFT

1.Remove:

- Crankshaft assembly ①
- Use the crankcase separating tool ②.



Crankcase separating tool:
P/N. YU-01135-A

NOTE:

Tighten the tool holding bolts, but make sure that the tool body is vertical with the crankshaft. If necessary, one screw may be backed out slightly to level tool body.

BEARINGS AND OIL SEALS

1.Remove:

- Oil seals
- Bearings

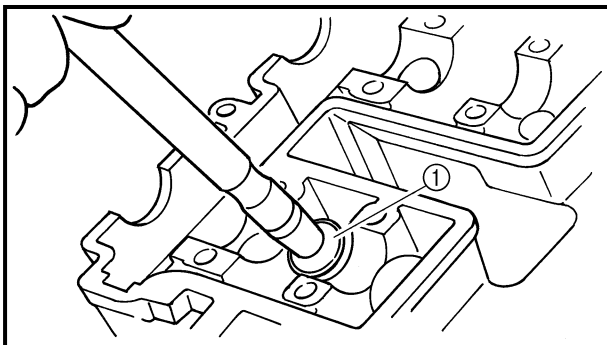

VALVE

NOTE:

Before removing the internal parts (valve, valve spring, valve seat etc.) of the cylinder head, the valve sealing should be checked.

1.Remove:

- Lifters ①
- Pads

NOTE:

Identify each lifter and pad position very carefully so that it can be reinstalled in its original place.

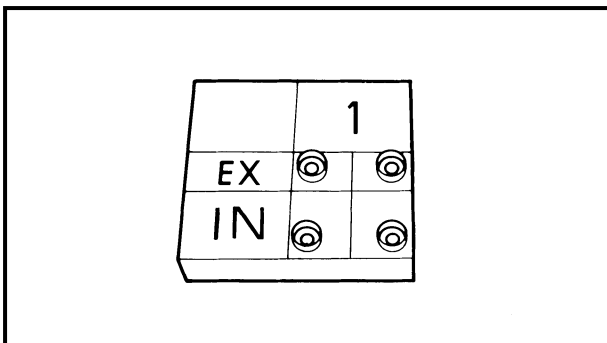



2.Check:

- Valve sealing

Leakage at valve seat → Inspect the valve face, valve seat and valve seat width. Refer to "INSPECTION AND REPAIR-VALVE SEAT".

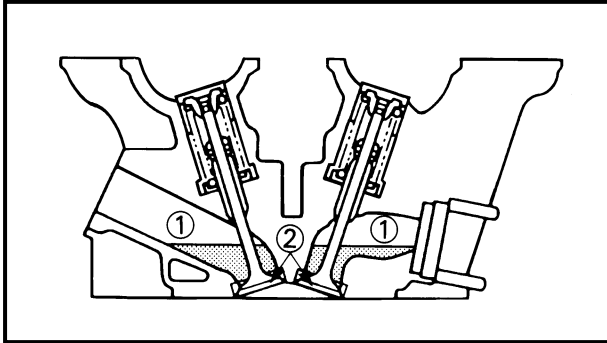

Checking steps:

- Pour a clean solvent ① into the intake and exhaust ports.
- Check the valve sealing.
There should be no leakage at the valve seat ②.

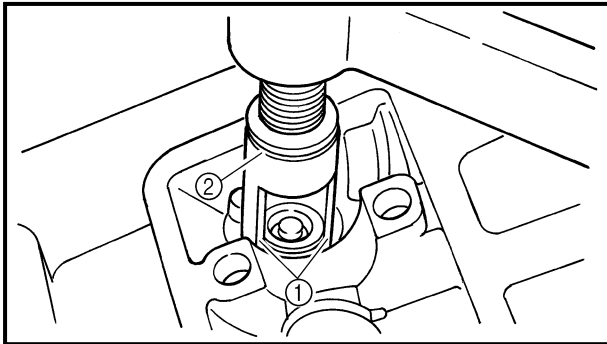

3.Remove:

- Valve cotters ①

NOTE:

Remove the valve cotters while compressing the valve spring with the valve spring compressor ②.



**Valve spring compressor:
P/N. YM-04019**

4.Remove:

- Valve retainer ①
- Oil seal ②
- Valve spring ③
- Spring seat ④
- Valve ⑤

NOTE:

Identify each part position very carefully so that it can be reinstalled in its original place.

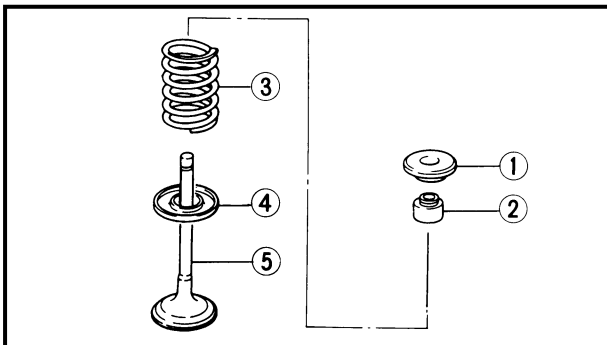

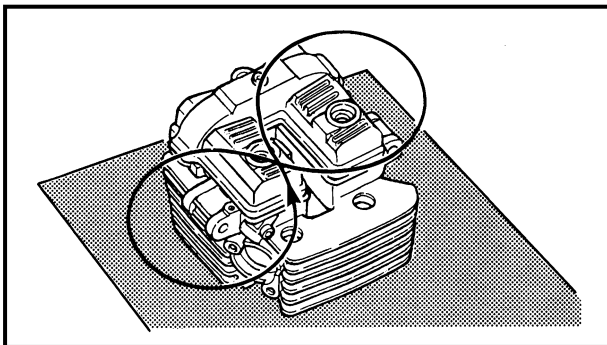
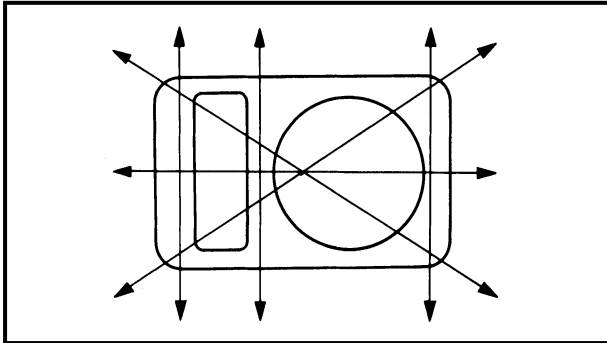
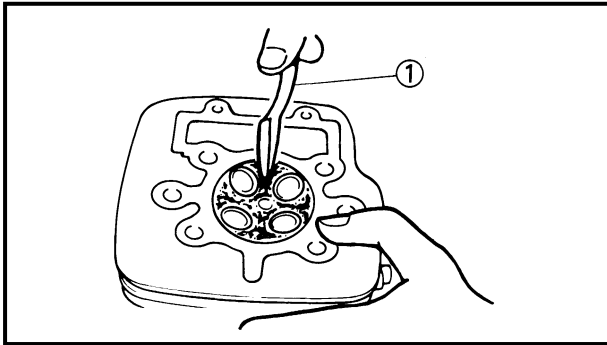

NB243001

INSPECTION AND REPAIR

CYLINDER HEAD

1. Eliminate:

- Carbon deposit (from combustion chamber)
Use rounded scraper ①.

NOTE:

Do not use a sharp instrument and avoid damaging or scratching:

- Spark plug thread
- Valve seat

2. Inspect:

- Cylinder head
Scratches/damage → Replace.

3. Measure:

- Warpage
Out of specification → Resurface.

Cylinder head warpage:
Less than 0.03 mm (0.0012 in)

4. Resurface:

- Cylinder head

Resurfacement steps:

- Place a 400 ~ 600 grit wet sandpaper on the surface plate, and resurface the head using a figure-eight sanding pattern.

NOTE:

Rotate the head several times to avoid removing too much material from one side.

NB243002

VALVE SEAT

1. Eliminate:

- Carbon deposit (from valve face and valve seat)

2. Inspect:

- Valve seat
Pitting/wear → Reface the valve seat.

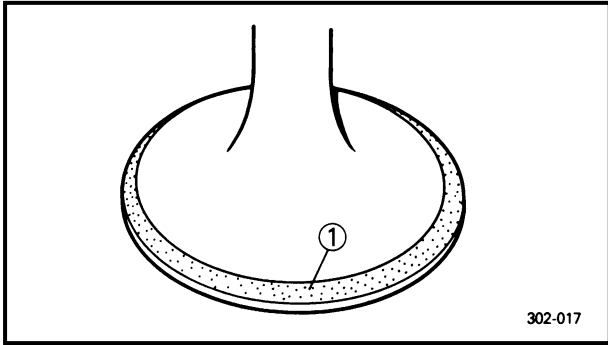
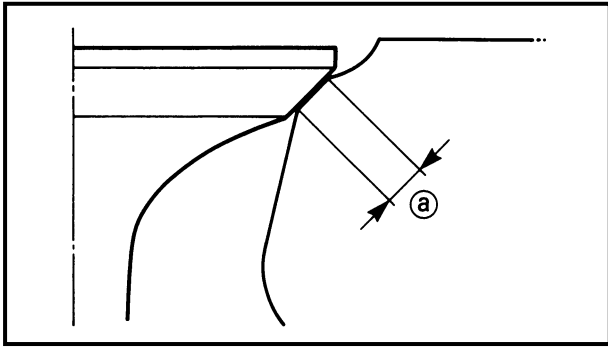

3.Measure:

- Valve seat width ②
- Out of specification → Reface the valve seat.

Valve seat width:
Intake:
 0.9 ~ 1.1 mm (0.035 ~ 0.043 in)
Exhaust:
 0.9 ~ 1.1 mm (0.035 ~ 0.043 in)

Measurement steps:

- Apply the Mechanic's blueing dye (Dykem) ① to the valve face.
- Install the valve into the cylinder head.
- Press the valve through the valve guide and onto the valve seat to make a clear pattern.
- Measure the valve seat width. Wherever the valve seat and valve face made contact, blueing will have been removed.
- If the valve seat width is too wide, too narrow, or seat has not centered, the valve seat must be refaced.

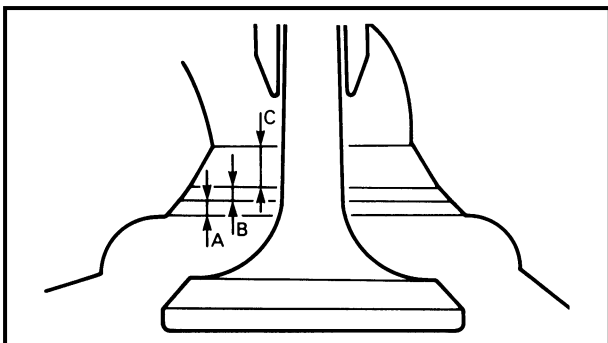
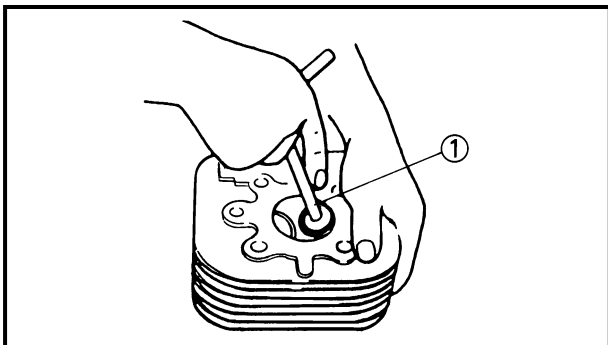

4.Reface:

- Valve seat
- Use a 30°, 45° and 60° valve seat cutter ①.

When twisting the cutter, keep an even downward pressure (4 ~ 5 kg) to prevent chatter marks.

Cut section as follows	
Section	Cutter
A	30°
B	45°
C	60°



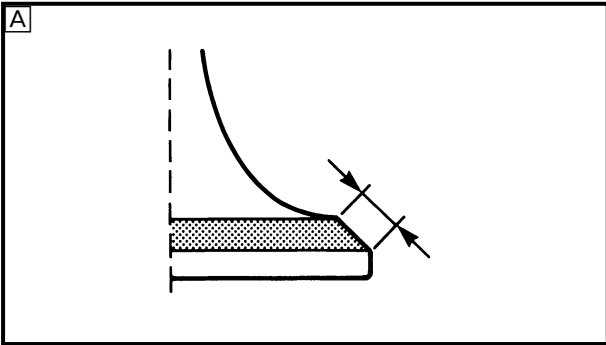

Refacing steps:

A Valve seat is centered on the valve face but it is too wide.

Valve seat cutter set		Desired result
Use lightly	45° cutter 60° cutter	To reduce valve seat width to 1.0 mm (0.039 in).

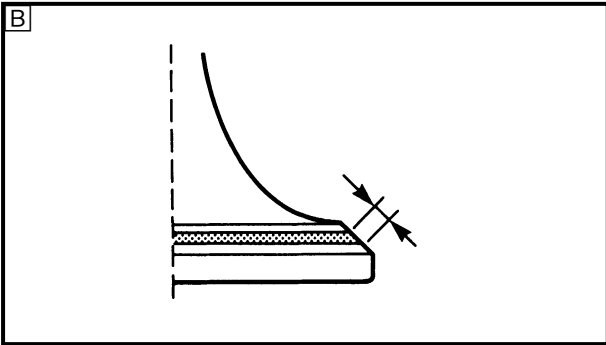

B Valve seat is in the middle of the face but it is too narrow.

Valve seat cutter set		Desired result
Use	45° cutter	To achieve a uniform valve seat width of 1.0 mm (0.039 in).

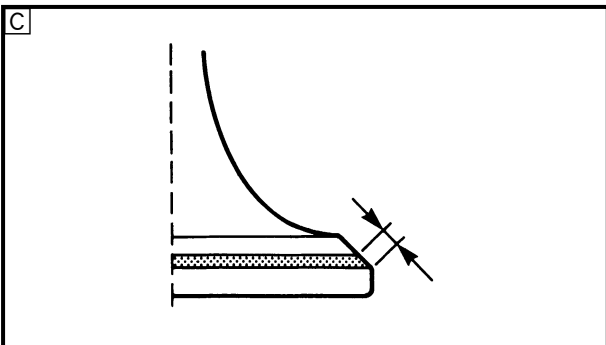

C Valve seat is too narrow and it is near valve margin.

Valve seat cutter set		Desired result
Use	First: 30° cutter Second: 45° cutter	To center the seat and to achieve its width of 1.0 mm (0.039 in).

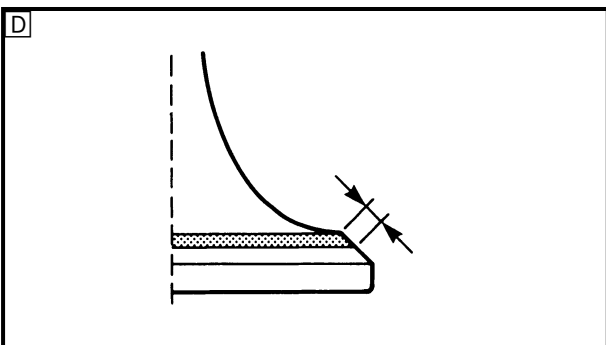

D Valve seat is too narrow and it is located near the bottom edge of the valve face.

Valve seat cutter set		Desired result
Use	First: 60° cutter Second: 45° cutter	To center the seat and increase its width.

5.Lap:

- Valve face
- Valve seat

NOTE:

After refacing the valve seat or replacing the valve and valve guide, the valve seat and valve face should be lapped.

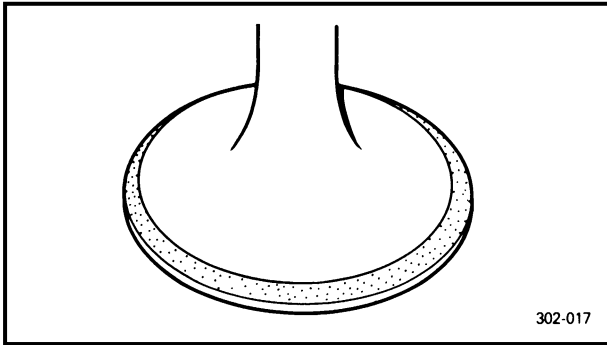

Lapping steps:

- Apply a coarse lapping compound to the valve face.



Be sure no compound enters the gap between the valve stem and guide.

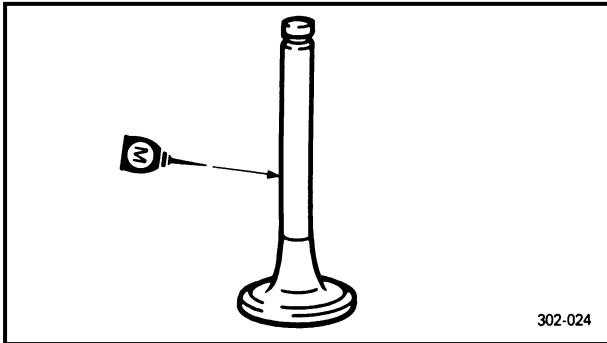

- Apply a molybdenum disulfide oil to the valve stem.
- Install the valve into the cylinder head.
- Turn the valve until the valve face and valve seat are evenly polished, then clean off all compound.

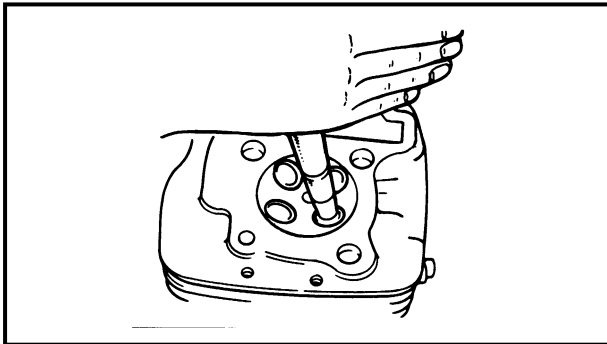

NOTE:

To obtain the best lapping results, lightly tap the valve seat while rotating the valve back and forth between your hands.

- Apply fine lapping compound to the valve face and repeat the above steps.

NOTE:

Be sure to clean off all compound from the valve face and valve seat after every lapping operation.

- Apply the Mechanic's blueing dye (Dykem) to the valve face.
- Install the valve into the cylinder head.
- Press the valve through the valve guide and onto the valve seat to make a clear pattern.
- Measure the valve seat width again.
- If the valve seat width is out of specification, reface and lap the valve seat.

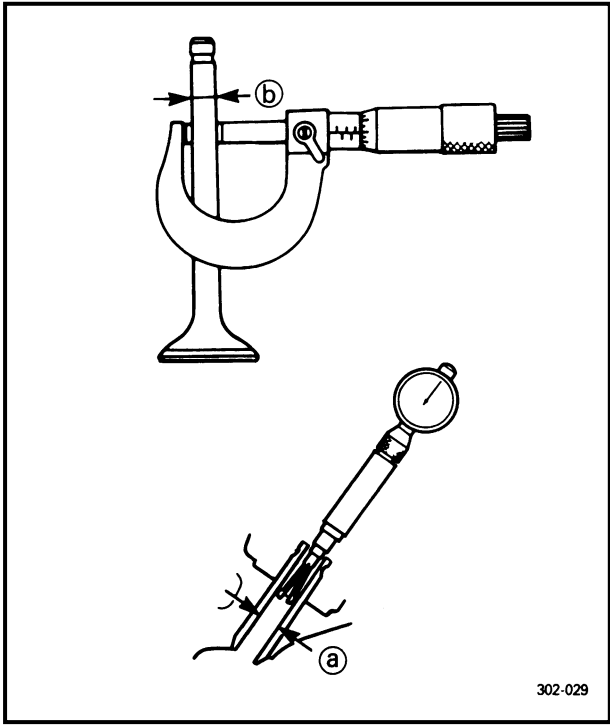

NB243003
VALVE AND VALVE GUIDE

- 1.Measure:
- Stem-to-guide clearance

Stem-to-guide clearance =
Valve guide inside diameter (a) –
Valve stem diameter (b)

Out of specification → Replace valve guide.

 **Stem-to-guide clearance:**
Intake:
 0.010 ~ 0.037 mm
 (0.0004 ~ 0.0015 in)
 <Limit>: 0.08 mm (0.0031 in)
Exhaust:
 0.025 ~ 0.052 mm
 (0.0010 ~ 0.0020 in)
 <Limit>: 0.10 mm (0.0039 in)

- 2.Replace:
- Valve guide

Replacement steps:

NOTE: _____
 Heat the cylinder head in an oven to 100 °C (212 °F) to ease guide removal and installation and to maintain correct interference fit.

- Remove the valve guide using the valve guide remover ①.
- Install the valve guide (new) using the valve guide installer ② and valve guide remover ①.
- After installing the valve guide, bore the valve guide using the valve guide reamer ③ to obtain proper stem-to-guide clearance.

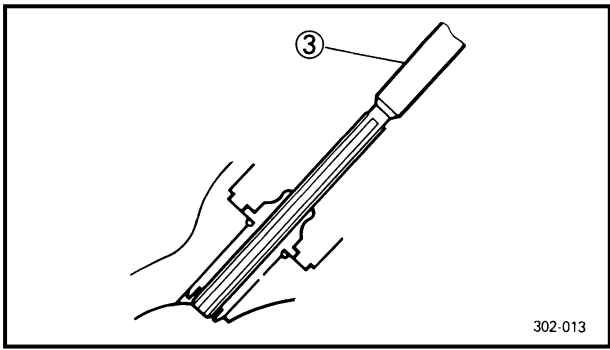
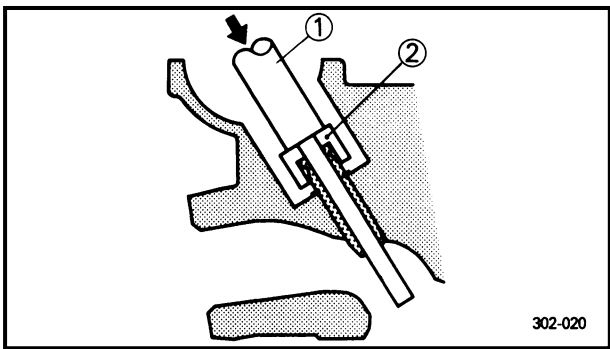
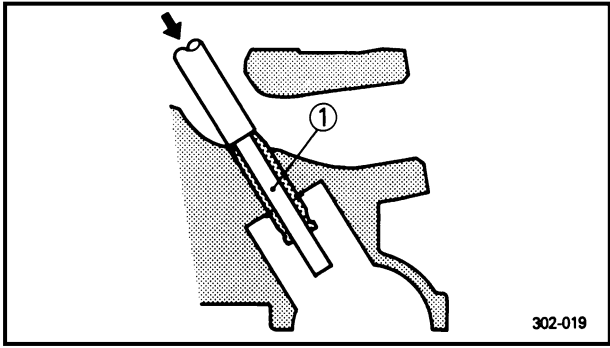

 **Valve guide remover:**
 5 mm (0.20 in):
 P/N. YM-04097
Valve guide reamer:
 5 mm (0.20 in):
 P/N. YM-04099
Valve guide installer:
 5 mm (0.20 in):
 P/N. YM-04098

NOTE: _____
 Reface the valve seat after replacing the valve guide.



3. Eliminate:

- Carbon deposit
(from valve face)

4. Inspect:

- Valve face
Pitting/wear → Grind the face.
- Valve stem end
Mushroom shape or diameter larger than the body of the stem → Replace.

5. Measure:

- Margin thickness [Ⓐ]
Out of specification → Replace.

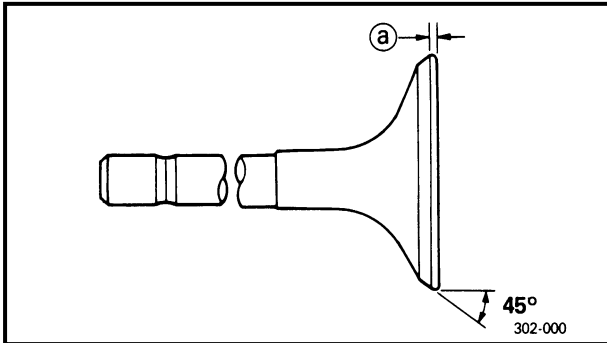

Margin thickness:

IN: 0.6 ~ 1.0 mm (0.02 ~ 0.04 in)

EX: 0.8 ~ 1.2 mm (0.03 ~ 0.05 in)

6. Measure:

- Runout (valve stem)
Out of specification → Replace.

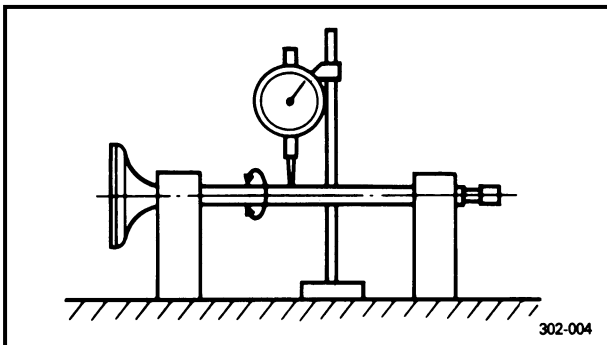

Runout:

Less than 0.010 mm (0.0004 in)

NOTE:

- Always replace the guide if the valve is replaced.
- Always replace the oil seal if the valve is removed.

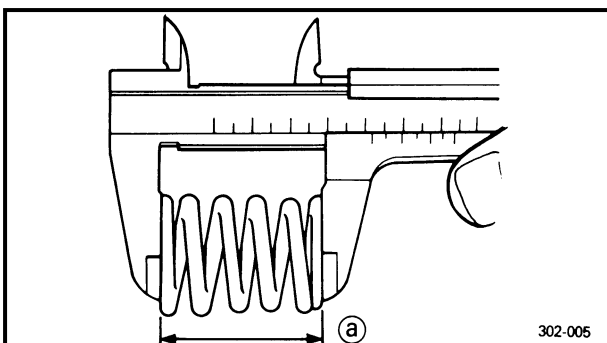

NB243004

VALVE SPRING

1. Measure:

- Free length [Ⓐ] (valve spring)
Out of specification → Replace.



Free length (valve spring)

Intake

33.81 ~ 35.59 mm

Exhaust

(13.31 ~ 14.01 in)

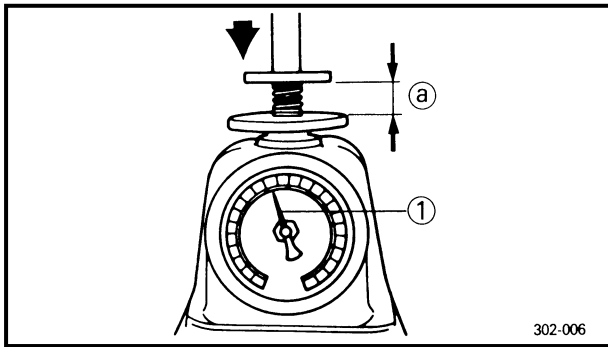

302-006

2.Measure:

- Compressed force ① (valve spring)
Out of specification → Replace.
- ① Installed length

	Compressed force:
	Spring at 30.39 mm (1.20 in)
Intake	9.3 ~ 10.7 kg (20.53 ~ 23.62 lb)
Exhaust	9.3 ~ 10.7 kg (20.53 ~ 23.62 lb)

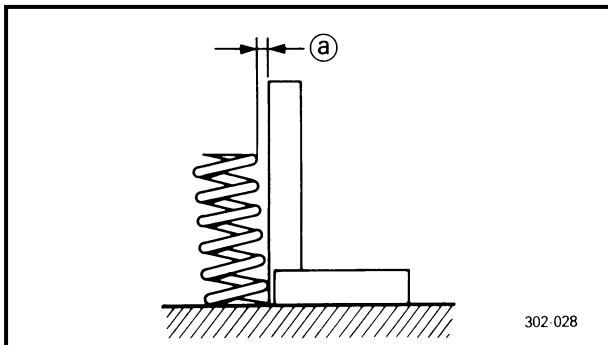

302-028

3.Measure:

- Spring tilt ①
Out of specification → Replace.

	Spring tilt:
	Intake:
	Less than 1.6 mm (0.063 in)
	Exhaust:
	Less than 1.6 mm (0.063 in)

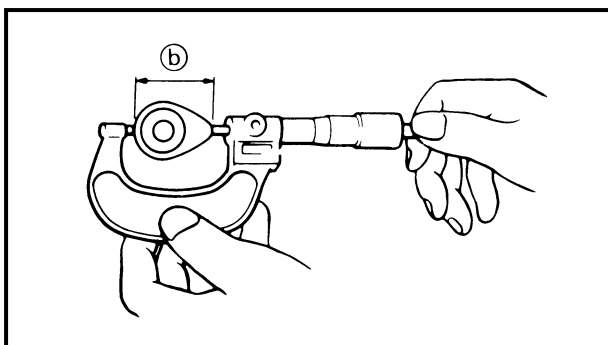
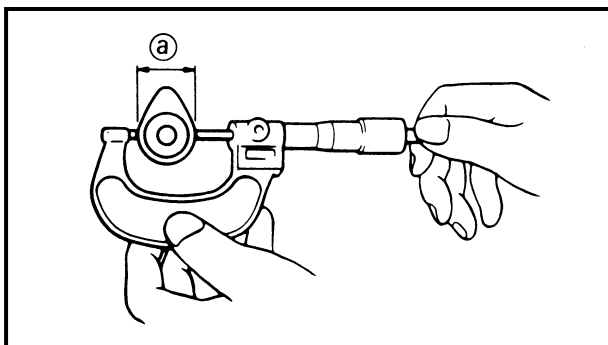

NB243005

CAMSHAFT

1.Inspect:

- Cam lobes
Pitting/scratches/blue discoloration → Replace.

2.Measure:

- Cam lobes length ① and ②
Out of specification → Replace.

	Cam lobes length:
	Intake, Exhaust:
	① 25.00 ~ 25.10 mm (0.9843 ~ 0.9882 in)
	② 32.75 ~ 32.85 mm (1.2894 ~ 1.2933 in)

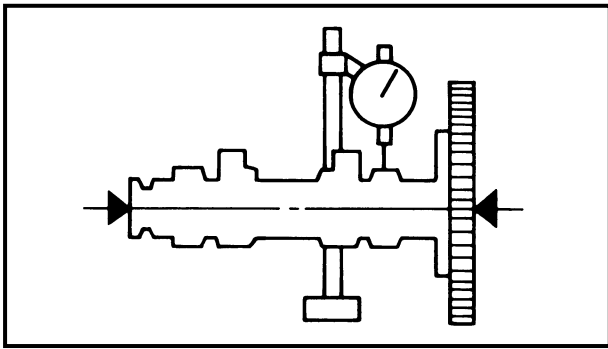

3.Measure:

- Runout (camshaft)
Out of specification → Replace.



Runout (camshaft):
Less than 0.03 mm (0.0012 in)

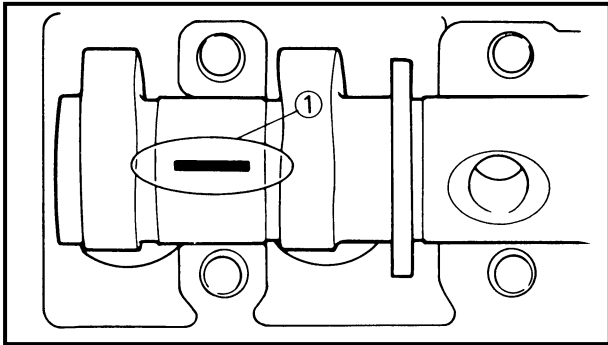

4.Measure:

- Camshaft-to-cap clearance
Out of specification → Measure bearing diameter (camshaft).



Camshaft-to-cap clearance:
0.020 ~ 0.054 mm
(0.0008 ~ 0.0021 in)

Measurement steps:

- Install the camshaft onto the cylinder head.
- Position a strip of Plastigauge® ① onto the camshaft.
- Install the dowel pins and camshaft caps.



Bolt (camshaft cap):
10 Nm (1.0 m • kg, 7.2 ft • lb)

NOTE:

- Tighten the camshaft caps in a crisscross pattern from innermost to outer.
- Do not turn the camshaft when measuring clearance with the Plastigauge®.
- Remove the camshaft caps and measure the width of the Plastigauge®.

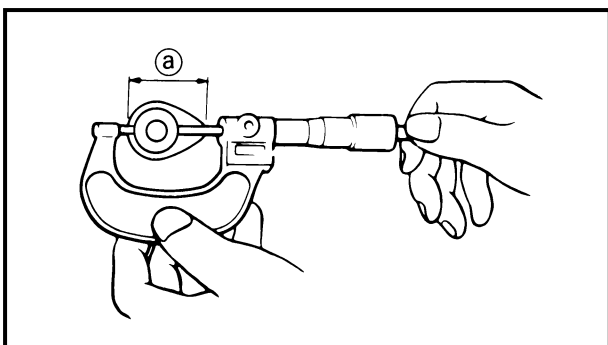

5.Measure:

- Bearing diameter @ (camshaft)
Out of specification → Replace camshaft.
Within specification → Replace cylinder head.



Bearing diameter (camshaft):
24.467 ~ 24.480 mm
(0.9633 ~ 0.9638 in)

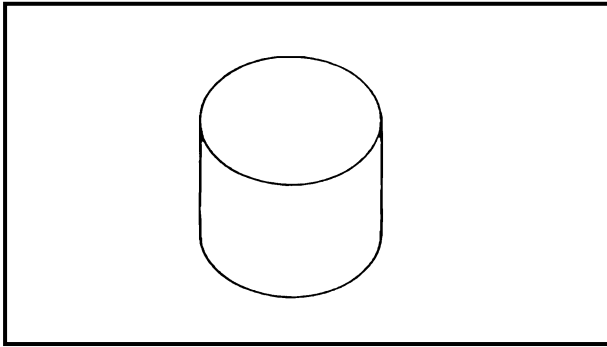

NB643006

VALVE LIFTER

1. Inspect:

- Valve lifters
Scratches/damage → Replace both lifters and camshaft case.

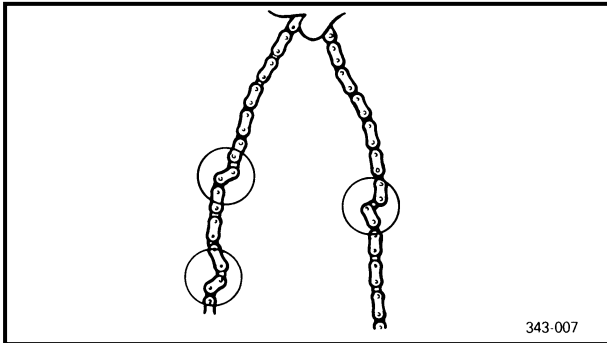

343-007

NB643007

TIMING CHAIN, SPROCKET AND CHAIN GUIDE

1. Inspect:

- Timing chain
Stiff/cracks → Replace the timing chain and the sprockets as a set.

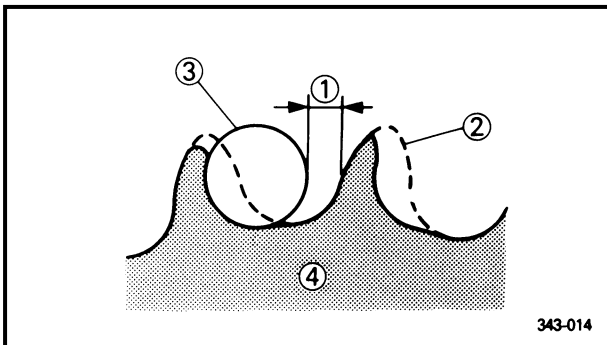

343-014

2. Inspect:

- Cam sprocket
Wear/damage → Replace the cam sprockets and the timing chain as a set.

- ① 1/4 tooth
- ② Correct
- ③ Roller
- ④ Sprocket

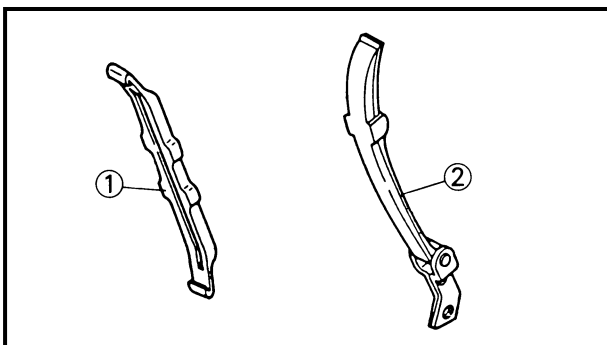

3. Inspect:

- Chain guide ① (exhaust side)
- Chain guide ② (intake side)
Wear/damage → Replace.

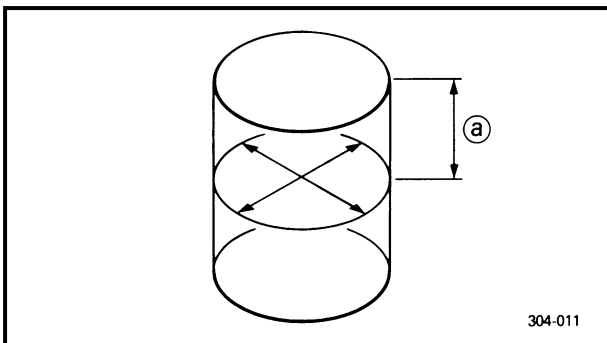
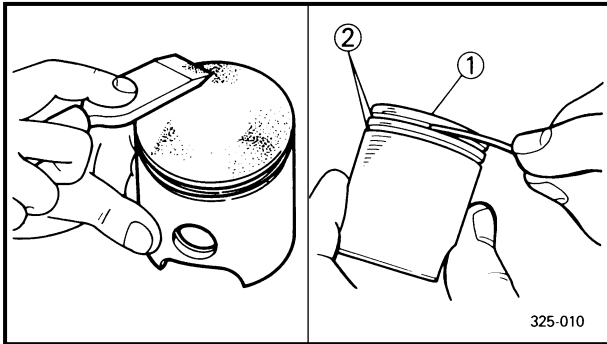
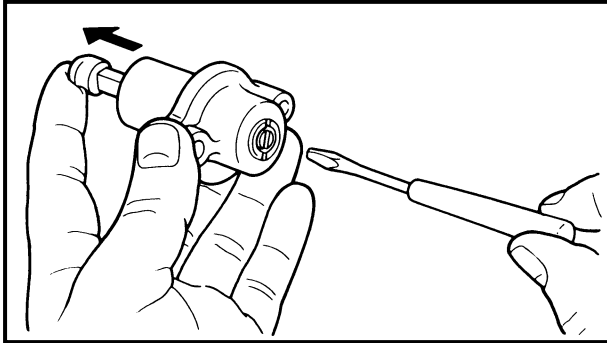
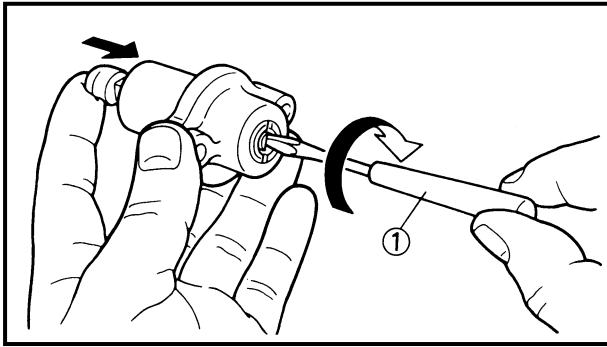

4.Check:

- Timing chain tensioner movement

Checking steps:

- While pressing the tensioner rod lightly with fingers, use a thin screwdriver ① and wind the tensioner rod up fully clockwise.
- When releasing the screwdriver by pressing lightly with fingers, make sure that the tensioner rod will come out smoothly.
- If not, replace the tensioner assembly.

NB243008

CYLINDER AND PISTON

1.Eliminate:

- Carbon deposits (from the piston crown ① and ring grooves ②.)

2.Inspect:

- Piston wall
Wear/scratches/damage → Replace.

3.Eliminate:

- Score marks and lacquer deposits (from the side of the piston)
Use a 600 ~ 800 grit wet sandpaper.

NOTE:

Sand in a crisscross pattern. Do not sand excessively.

4.Inspect:

- Cylinder wall
Wear/scratches → Rebore or replace.

5.Measure:

- Piston-to-cylinder clearance

Measurement steps:

1st steps:

- Measure the cylinder bore "C" with a cylinder bore gauge.
① 40 mm (1.6 in) from the cylinder top



NOTE:

Measure the cylinder bore "C" in parallel to and at right angles to the crankshaft. Then, find the average of the measurements.

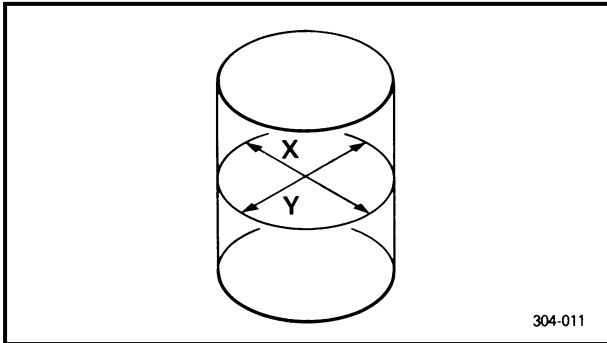

304-011

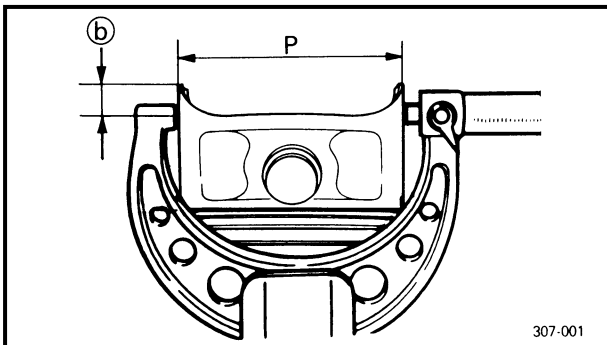

307-001



Cylinder bore "C":
 72.970 ~ 73.020 mm
 (2.873 ~ 2.875 in)
 <Limit: 73.1 mm (2.878 in)>

$C = (X + Y)/2$

- If out of specification, rebore or replace the cylinder, and replace the piston and piston rings as a set.

2nd steps:

- Measure the piston skirt diameter "P" with a micrometer.
- ⓑ 4.0 mm (0.16 in) from the piston bottom edge



Piston skirt diameter "P":
 72.920 ~ 72.970 mm
 (2.871 ~ 2.873 in)

- If out of specification, replace the piston and piston rings as a set.

3rd steps:

- Find the piston-to-cylinder clearance with following formula.

Piston-to-cylinder clearance =
Cylinder bore "C" -
Piston skirt diameter "P"



Piston-to-cylinder clearance:
 0.040 ~ 0.060 mm
 (0.0016 ~ 0.0024 in)
 <Limit: 0.1 mm (0.004 in)>

- If out of specification, rebore or replace the cylinder, and replace the piston and piston rings as a set.

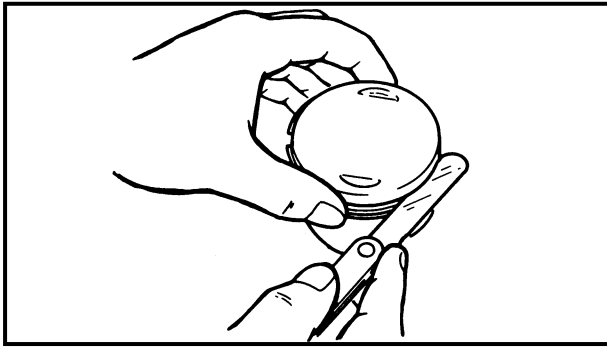

NB243009

PISTON RING

1.Measure:

- Side clearance

Out of specification → Replace the piston and the piston rings as a set.

NOTE:

Clean carbon from piston ring grooves and rings before measuring side clearance.

**Side clearance:****Top ring:**

0.040 ~ 0.080 mm
(0.0016 ~ 0.0031 in)

2nd ring:

0.030 ~ 0.070 mm
(0.0012 ~ 0.0028 in)

2.Position:

- Piston ring
(into the cylinder)

NOTE:

Push the ring with the piston crown so that the ring will be at a right angle to cylinder bore.

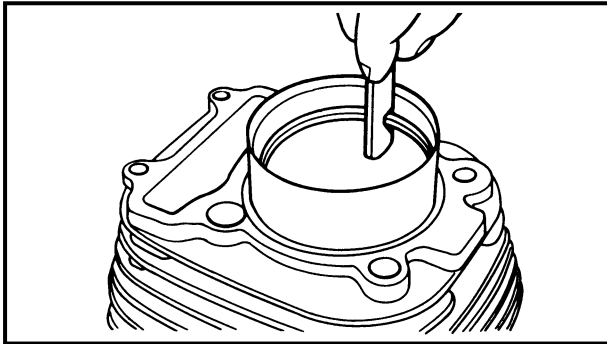

3.Measure:

- End gap

Out of specification → Replace.

NOTE:

You cannot measure the end gap on the expander spacer of the oil control ring. If the oil control ring rails show excessive gap, replace all three rings.

**End gap:****Top ring:**

0.20 ~ 0.35 mm (0.008 ~ 0.014 in)

2nd ring:

0.20 ~ 0.35 mm (0.008 ~ 0.014 in)

Oil ring:

0.20 ~ 0.70 mm (0.008 ~ 0.028 in)

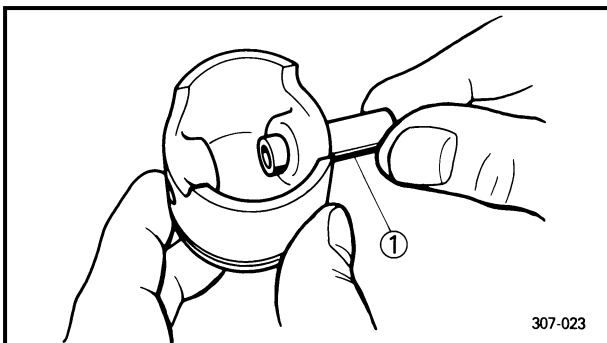

307-023

NB243010

PISTON PIN

1.Inspect:

- Piston pin ①

Blue discoloration/groove → Replace, then inspect lubrication system.

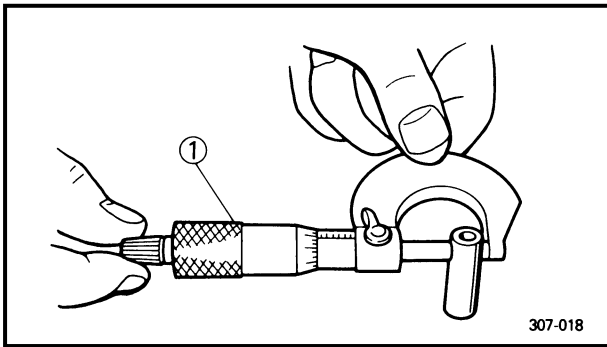

2.Measure:

- Piston pin outside diameter
Out of specification → Replace.



Outside diameter (piston pin):
17.991 ~ 18.000 mm
(0.7083 ~ 0.7087 in)

① Micrometer

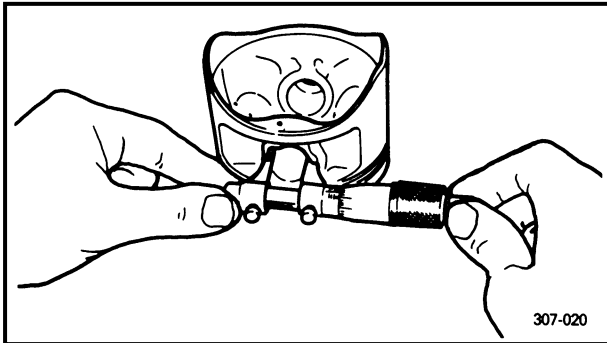

3.Measure:

- Piston pin bore inside diameter
Out of specification → Replace.



Piston pin bore inside diameter:
18.004 ~ 18.015 mm
(0.7088 ~ 0.7093 in)

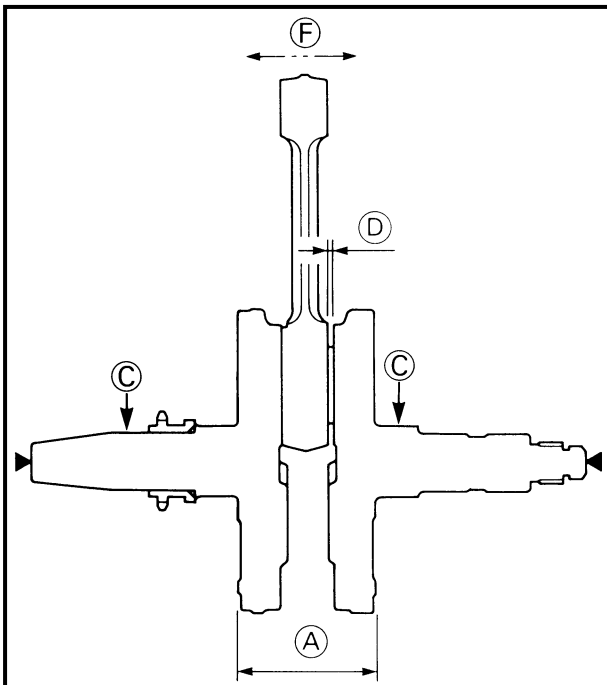

CRANKSHAFT

1.Measure:

- Crank width (A)
Out of specification → Replace crankshaft.



Crank width:
60.25 ~ 60.30 mm (2.372 ~ 2.374 in)

- Runout (C)
Out of specification → Replace crankshaft and/or bearing.



Runout limit:
0.03 mm (0.0012 in)

- Big end side clearance (D)
Out of specification → Replace big end bearing, crank pin and/or connecting rod.



Big end side clearance:
0.35 ~ 0.85 mm (0.013 ~ 0.033 in)

- Small end free play (F)
Out of specification → Replace connecting rod.



Small end free play:
0.8 mm (0.03 in)

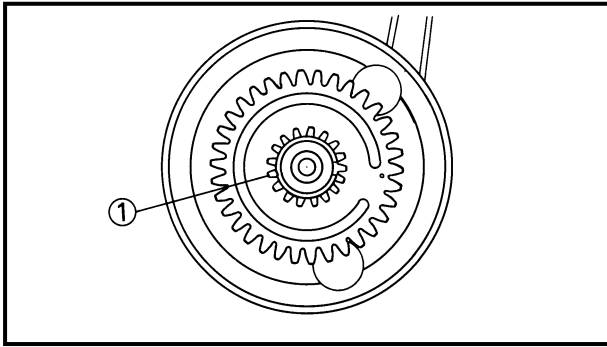

2. Inspect:

- Crankshaft sprocket (cam chain sprocket) ①
Wear/damage → Replace the crankshaft.

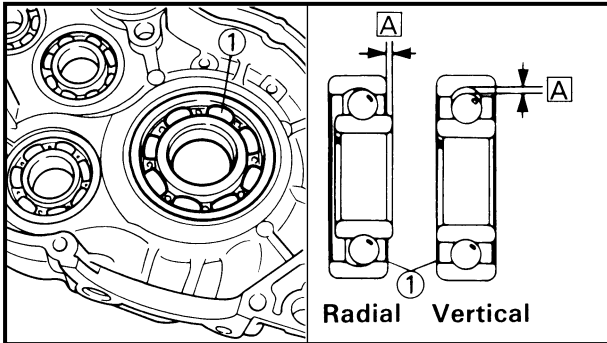

3. Inspect:

- Crankcase bearing ①
Abnormal noise/turn roughly/free play → Replace.
A Free play

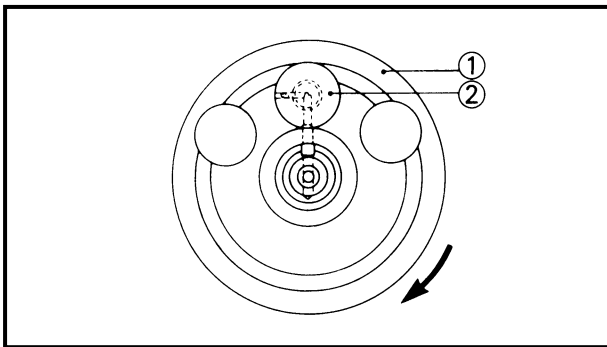

Crankshaft reassembling point:

The crankshaft ① and the crank pin ② oil passages must be properly interconnected with a tolerance of less than 1 mm (0.04 in).

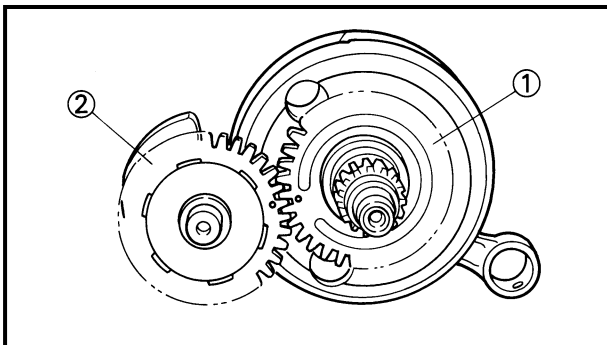

BALANCER DRIVE GEAR AND BALANCER GEAR

1. Inspect:

- Balancer drive gear teeth ①
- Balancer gear teeth ②
Wear/damage → Replace both gears.

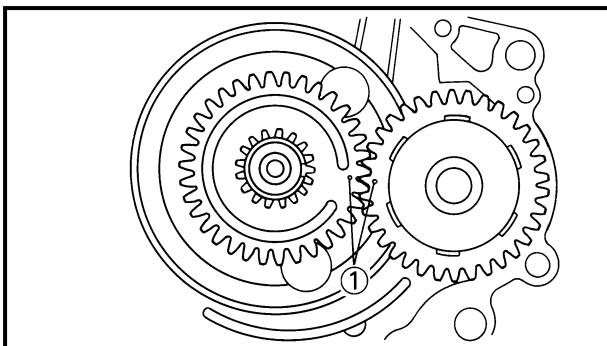

2. Inspect:

- Match marks ①
If they are not aligned → Align match marks as shown.

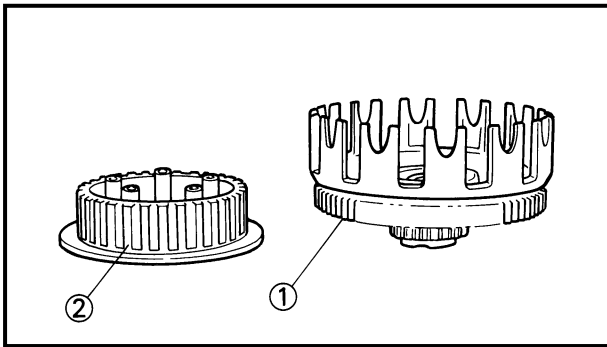

NB243013

PRIMARY DRIVE

1. Inspect:

- Primary driven gear teeth ①
- Clutch boss ②

Wear/damage → Replace.

Excessive noise during operation → Replace.

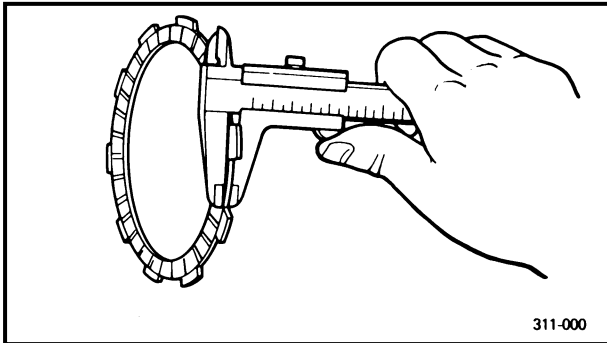

NB243014

CLUTCH

1. Inspect:

- Friction plate
- Damage/wear → Replace friction plates as a set.

2. Measure:

- Friction plate thickness
- Out of specification → Replace friction plates as a set.
Measure at all four points.

	Thickness	Wear limit
Type "A" (7 pcs.)	2.90 ~ 3.10 mm (0.114 ~ 0.122 in)	2.7 mm (0.106 in)

3. Inspect:

- Clutch plate
- Damage → Replace clutch plates as a set.

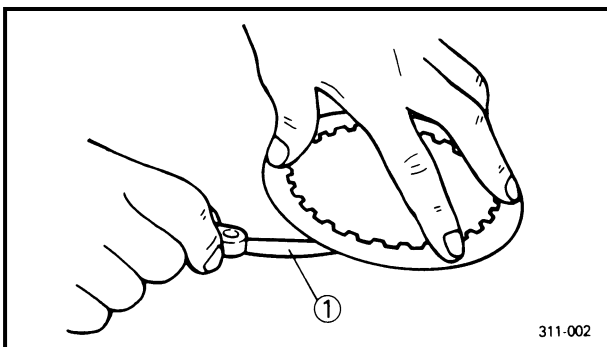

4. Measure:

- Clutch plate warpage
- Out of specification → Replace clutch plates as a set.
Use a surface plate and feeler gauge ①.

	Warp limit: Less than 0.05 mm (0.002 in)
---	--

5. Inspect:

- Clutch spring
- Damage → Replace as a set.

6. Measure:

- Clutch spring free length ②
- Out of specification → Replace springs as a set.

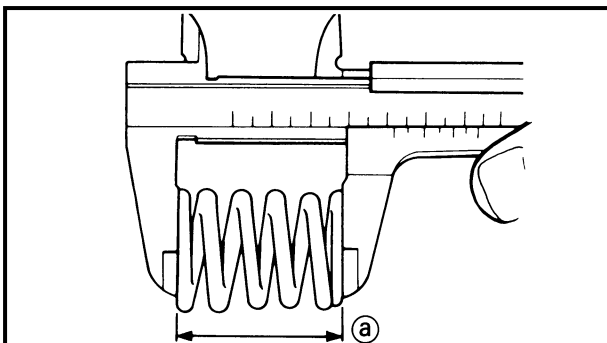

	Free length (clutch spring): 42.8 mm (1.685 in) <Limit>: 40.8 mm (1.606 in)
---	--

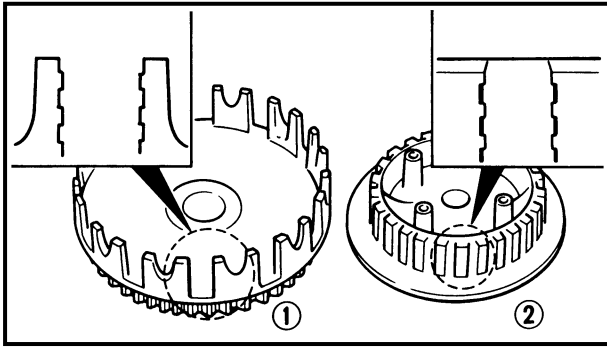

7. Inspect:

- Dogs on the primary driven gear ①
Scoring/wear/damage → Deburr or replace.
- Clutch boss splines ②
Scoring/wear/damage → Replace the clutch boss.

NOTE:

Scoring on the clutch housing dogs and the clutch boss splines will cause erratic operation.

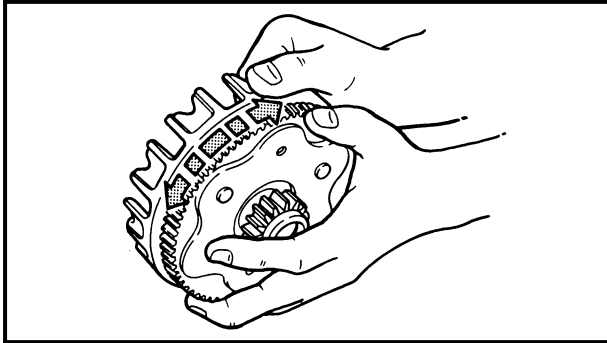

8. Check:

- Circumferential play
Free play exists → Replace.

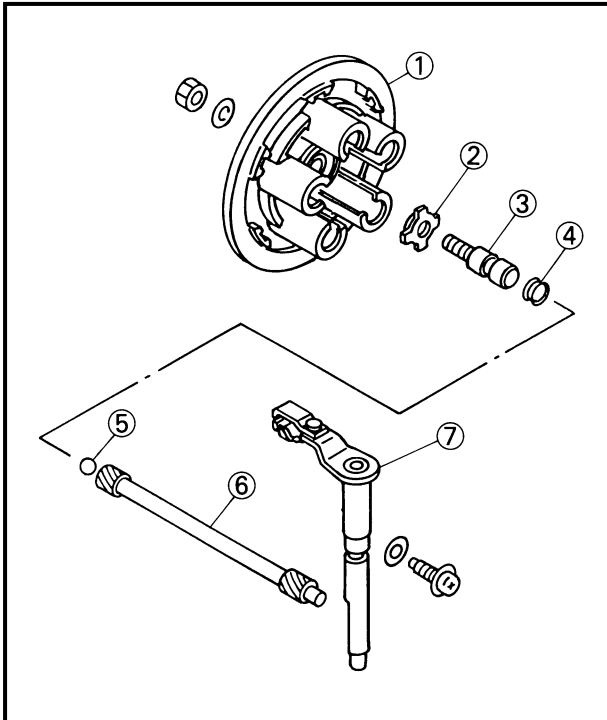

9. Inspect:

- Pressure plate ①
- Push plate ②
- Push rod 1 ③
- O-ring ④
- Ball ⑤
- Push rod 2 ⑥
- Push lever ⑦
Wear/bend/damage → Replace.

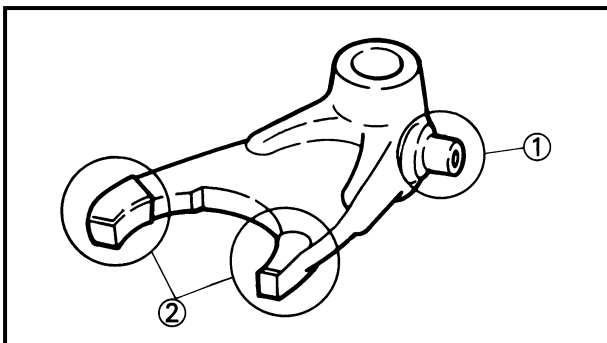

NB243015

TRANSMISSION AND SHIFTER

1. Inspect:

- Shift fork cam follower ①
- Shift fork pawl ②
Scoring/bends/wear → Replace.

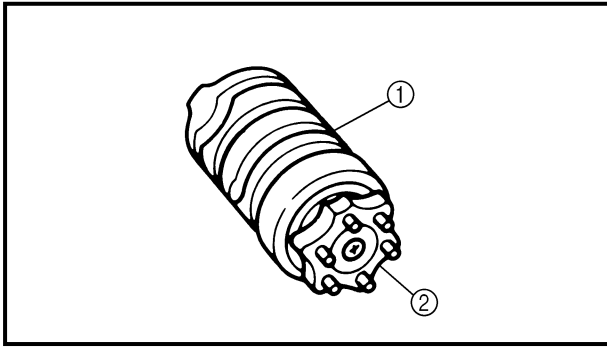

2. Inspect:
- Shift cam groove ①
 - Shift cam segment ②
- Wear/damage → Replace.

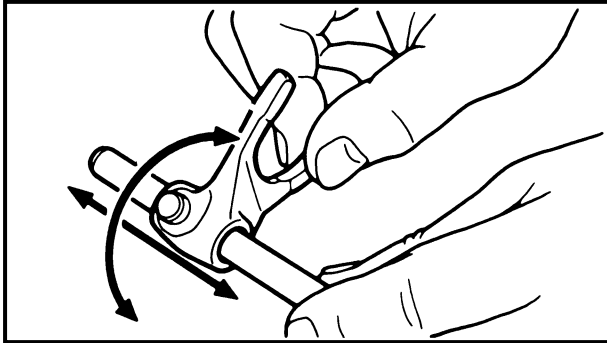

3. Check:
- Shift fork movement
- Unsmooth operation → Replace shift fork and/or guide bar.

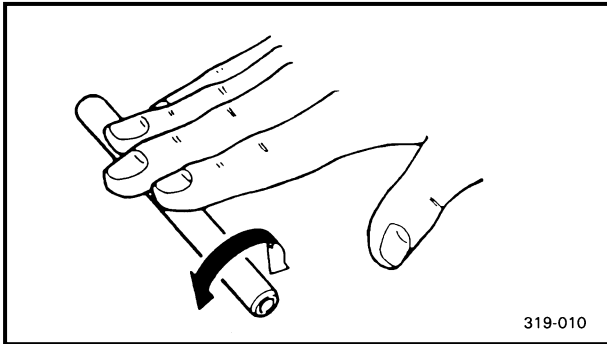

4. Check:
- Guide bar
- Roll the guide bar on a flat surface.
Bends → Replace.

⚠ WARNING

Do not attempt to straighten a bent guide bar.

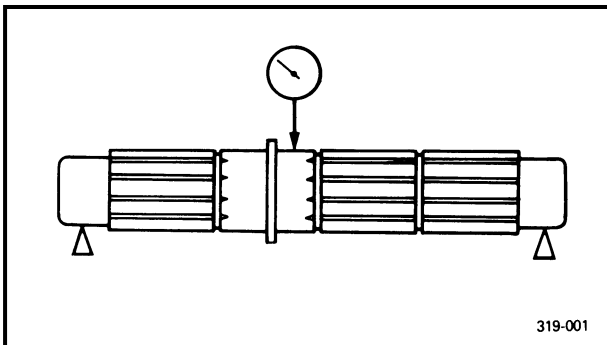

5. Measure:
- Runout (drive axle and main axle)
- Out of specification → Replace.

	Runout:
	Less than 0.08 mm (0.003 in)

⚠ WARNING

Do not attempt to straighten a bent axle.

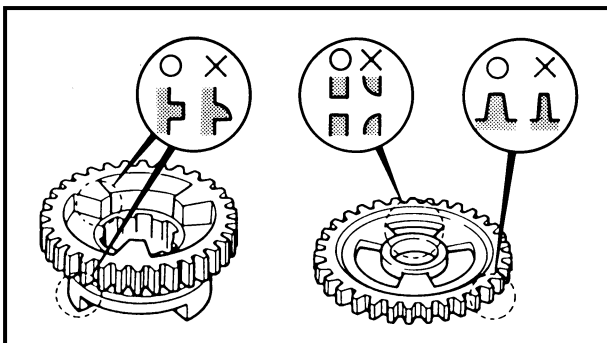

6. Inspect:
- Gear teeth
- Blue discoloration/pitting/wear → Replace.
- Mated dogs
- Rounded edges/cracks/missing portions → Replace.

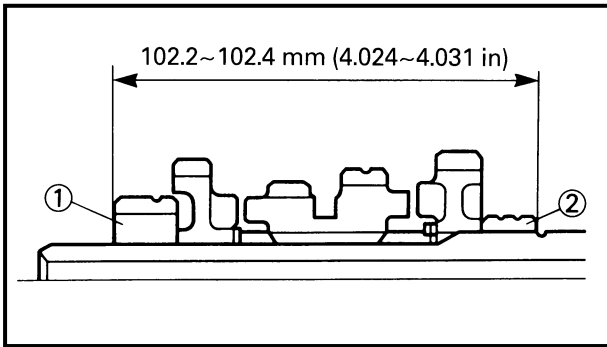

Reassembling point:

- Press the 2nd pinion gear ① in the main axle ② as shown.

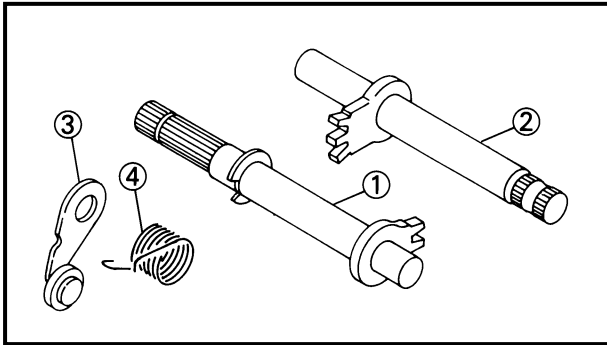

7. Inspect:

- Shift shaft 1 ①
 - Shift shaft 2 ②
 - Stopper lever ③
 - Torsion spring ④
- Cracks/damage → Replace.

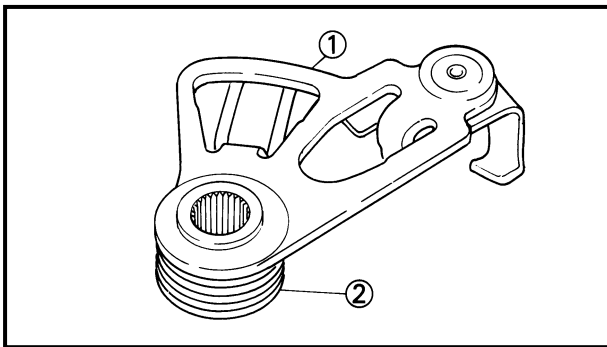

8. Inspect:

- Shift lever ①
 - Torsion spring ②
- Cracks/damage → Replace.

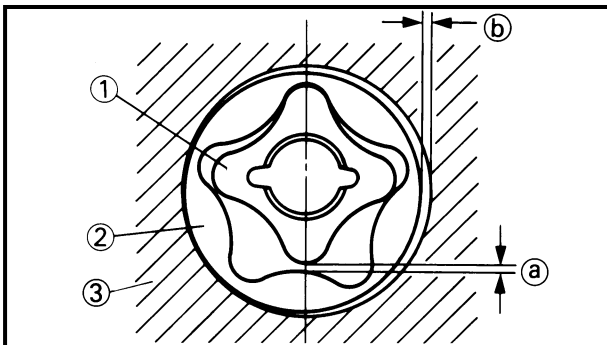

NB243016

OIL PUMP AND STRAINER

1. Measure:

- Tip clearance ①
(between inner rotor ① and outer rotor ②)
 - Side clearance ②
(between outer rotor ② and pump housing ③)
- Out of specification → Replace the oil pump.



Tip clearance:
0.15 mm (0.006 in)
Side clearance:
0.10 ~ 0.15 mm (0.004 ~ 0.006 in)

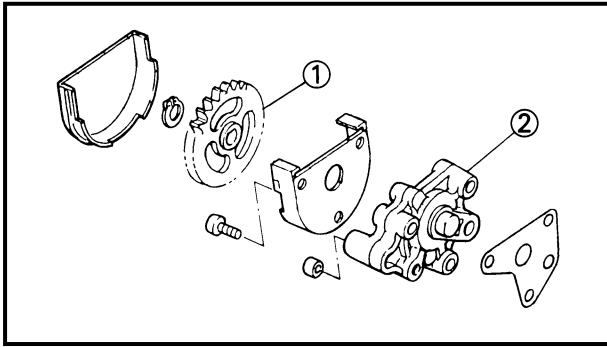

2. Inspect:
- Oil pump driven gear ①
 - Oil pump ②
- Wear/cracks/damage → Replace.
3. Inspect:
- Oil strainer
- Damage → Replace.

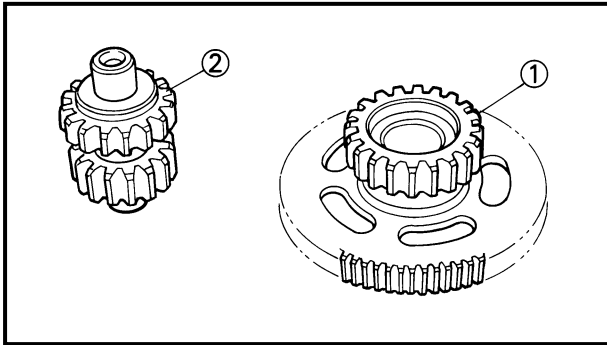

NB243012
ELECTRIC STARTER DRIVE

1. Inspect:
- Starter idle gear 1 teeth ①
 - Starter idle gear 2 teeth ②
- Burrs/chips/roughness/wear → Replace.

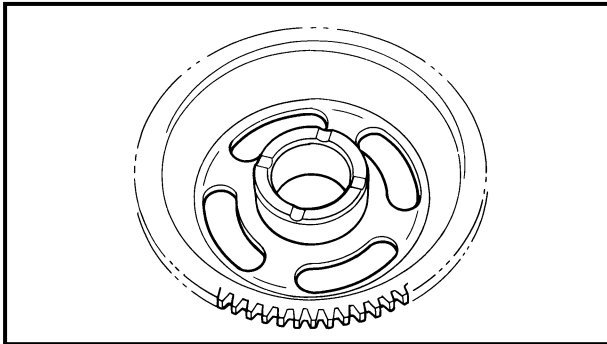

2. Inspect:
- Starter wheel gear (contacting surfaces)
- Pitting/wear/damage → Replace.

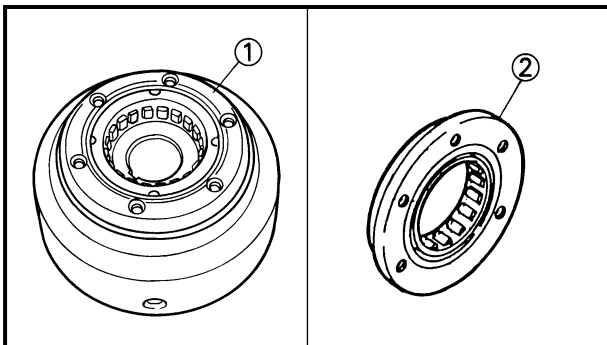

3. Inspect:
- Starter clutch assembly ①
 - Starter clutch ②
- Wear/damage → Replace.

4. Check:
- Starter clutch operation

Checking steps:

- Install the starter wheel gear to the starter clutch, and hold the starter clutch.
- When turning the starter wheel gear clockwise **A**, the starter clutch and the wheel gear should be engaged. If not, the starter clutch is faulty. Replace it.
- When turning the starter wheel gear counterclockwise **B**, the starter clutch gear should turn freely. If not, the starter clutch is faulty. Replace it.

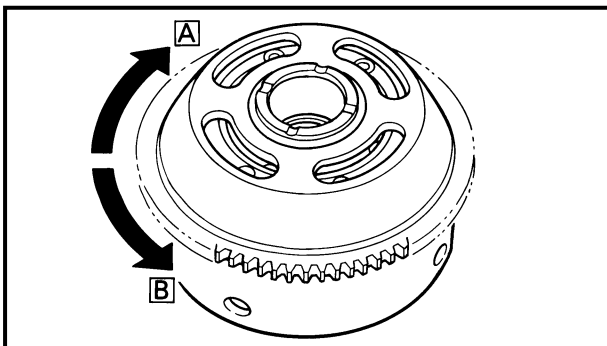

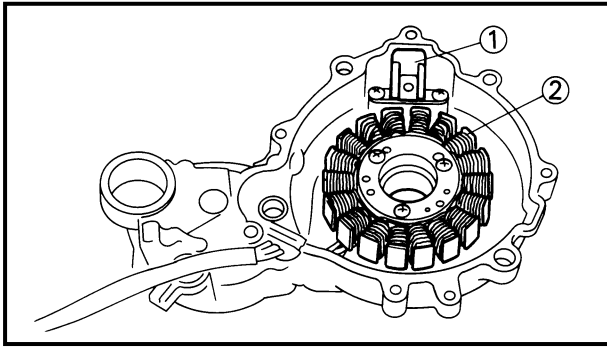

5. Inspect:
- Pickup coil ①
 - Stator coil ②
- Damage → Replace.

NB243018

CRANKCASE

1. Thoroughly wash the case halves with mild solvent.
2. Thoroughly clean all the gasket mating surfaces and crankcase mating surfaces.
3. Inspect:
 - Crankcase
Cracks/damage → Replace.
 - Oil delivery passages
Clog → Blow out with compressed air.

NB243019

BEARING AND OIL SEAL

1. Inspect:
 - Bearings
Clean and lubricate, then rotate inner race with finger.
Roughness → Replace.

CA

Do not use compressed air to spin the bearings dry. This causes damage to the surfaces.

2. Inspect:
 - Oil seals
Damage/wear → Replace.

NB243020

CIRCLIP AND WASHER

1. Inspect:
 - Circlips
 - Washers
Damage/looseness/bends → Replace.



ENGINE ASSEMBLY AND ADJUSTMENT
CRANKSHAFT AND BALANCER

- | | |
|-----------------------|-------------------|
| ① Bearing | ⑧ Balancer gear |
| ② Woodruff key | ⑨ Spring |
| ③ Crankshaft assembly | ⑩ Dowel pin |
| ④ Woodruff key | ⑪ Absorber plate |
| ⑤ Bearing | ⑫ Balancer weight |
| ⑥ Bearings | |
| ⑦ Buffer boss | |

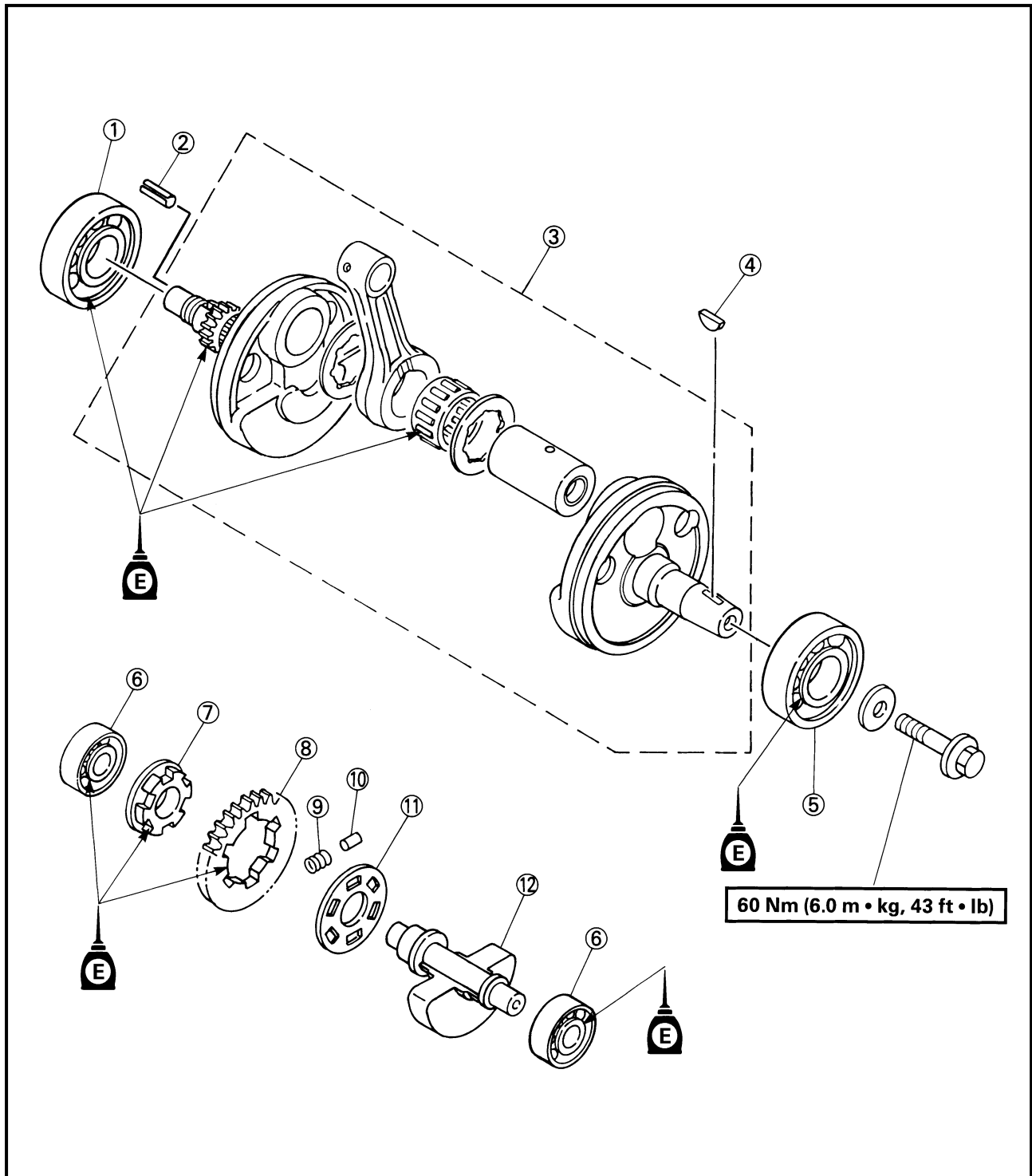

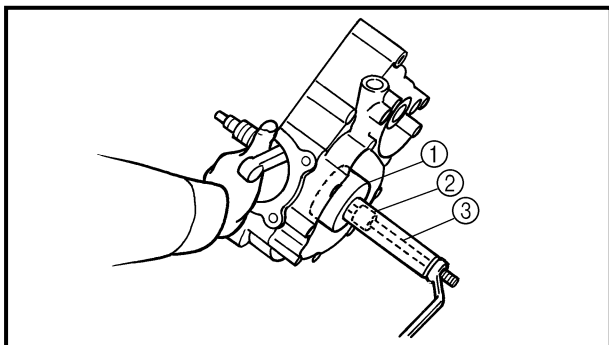
**CRANKSHAFT AND BALANCER SHAFT**

1.Attach:

- Crankshaft installing tool



Crank pot spacer ①:
P/N. YU-01202

Adapter #12 ②:
P/N. YU-90062

Crankshaft installer set ③:
P/N. YU-90050

2.Install:

- Crankshaft

NOTE:

Hold the connecting rod at top dead center with one hand while turning the nut of the installing tool with the other. Operate the installing tool until the crankshaft bottoms against the bearing.

CA

To protect the crankshaft against scratches or to make installation easier, apply grease to the oil seal lips and apply engine oil to each bearing.

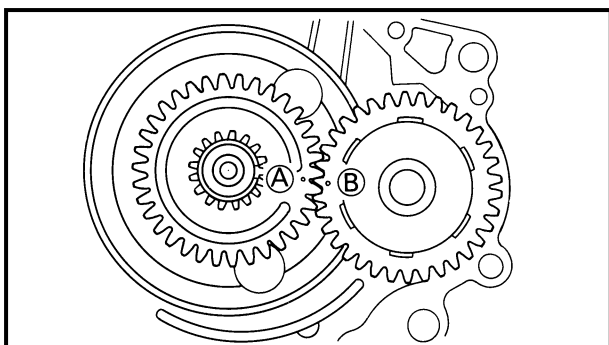

3.Install:

- Balancer shaft

NOTE:

When installing the balancer shaft, align the punched mark A on the crankshaft drive gear with the punched mark B on the balancer gear.



TRANSMISSION

- ① Drive sprocket
- ② Oil seal
- ③ Bearing
- ④ Drive axle
- ⑤ 2nd wheel gear
- ⑥ 5th wheel gear
- ⑦ 4th wheel gear
- ⑧ 3rd wheel gear
- ⑨ 6th wheel gear
- ⑩ 1st wheel gear
- ⑪ Bearing
- ⑫ Bearing
- ⑬ 2nd pinion gear
- ⑭ 5th pinion gear
- ⑮ 3rd/4th pinion gear
- ⑯ 6th pinion gear
- ⑰ Main axle
- ⑱ Bearing

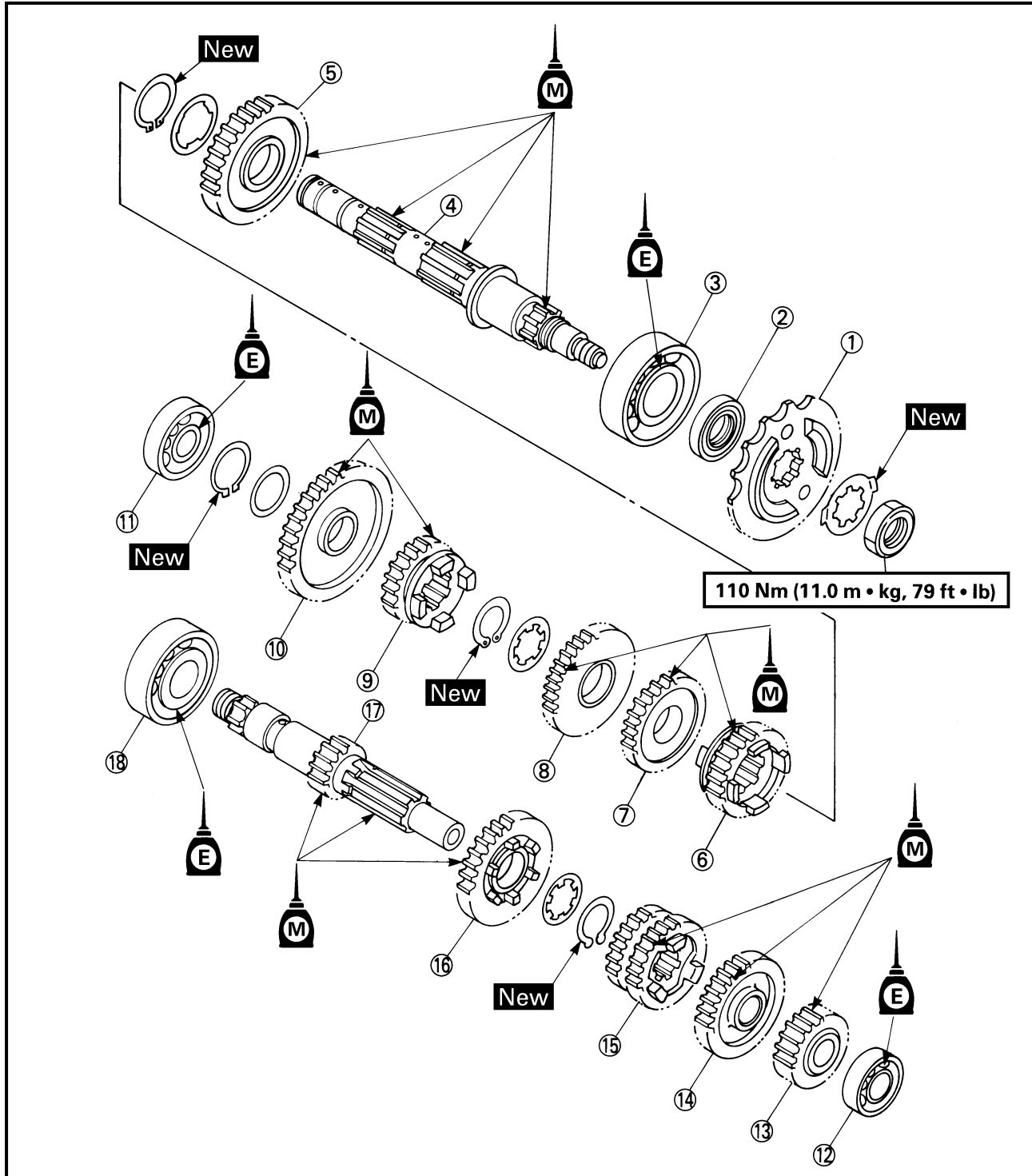



SHIFTER

- ① Shift shaft 1
- ② Shift shaft 2
- ③ Oil seal
- ④ Shift fork L
- ⑤ Shift fork C
- ⑥ Shift fork R
- ⑦ Shift fork guide bar
- ⑧ Shift cam
- ⑨ Torsion spring
- ⑩ Shift lever assembly
- ⑪ Stopper lever
- ⑫ Torsion spring

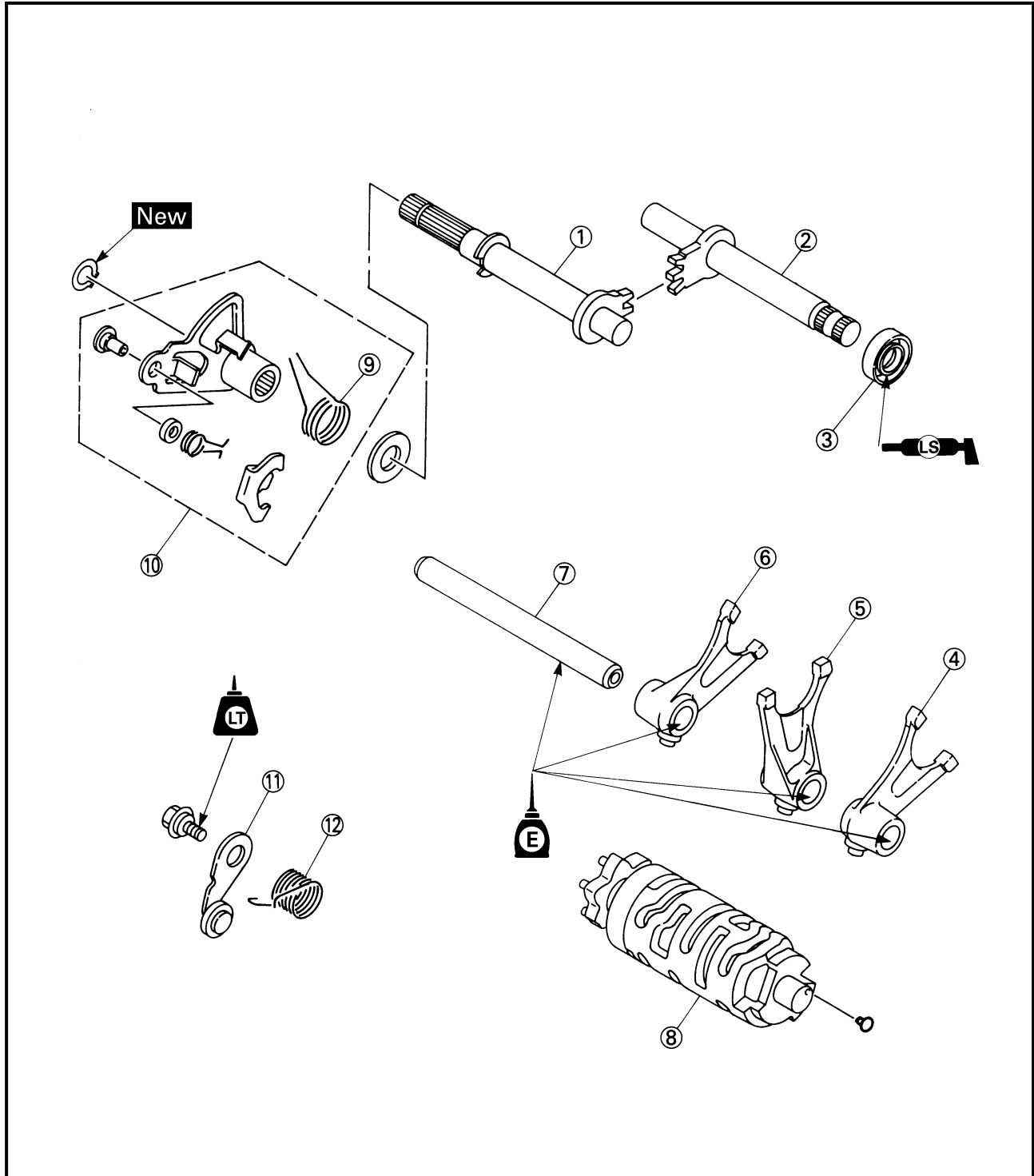

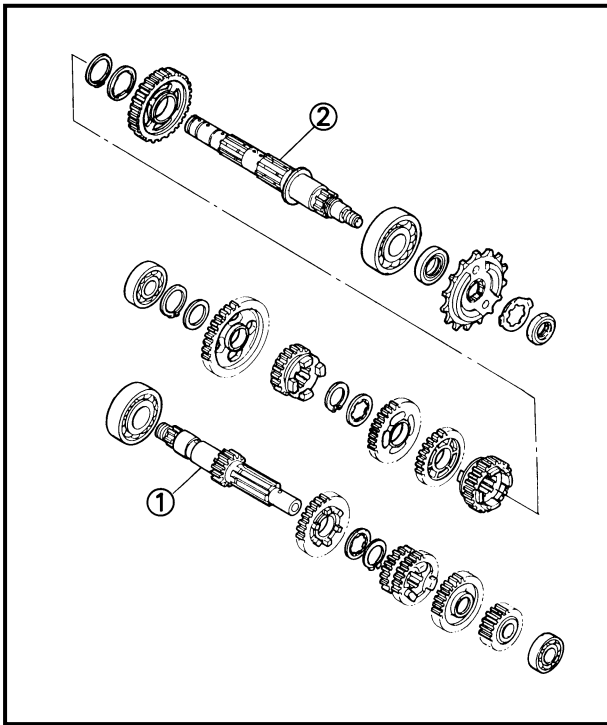

TRANSMISSION AND SHIFTER

1. Install:

- Neutral switch

2. Apply:

- Molybdenum disulfide oil
(onto the drive axle, main axle and gears)

3. Install:

- Drive axle assembly ①
- Main axle assembly ②

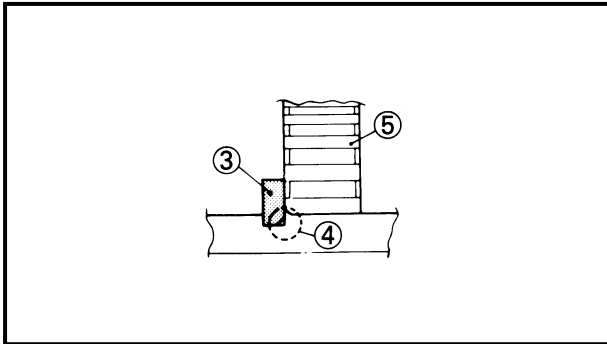

- Circlip ③

Install the chamfered side ④ facing the gear ⑤.

⚠ WARNING

Always use a new circlip.

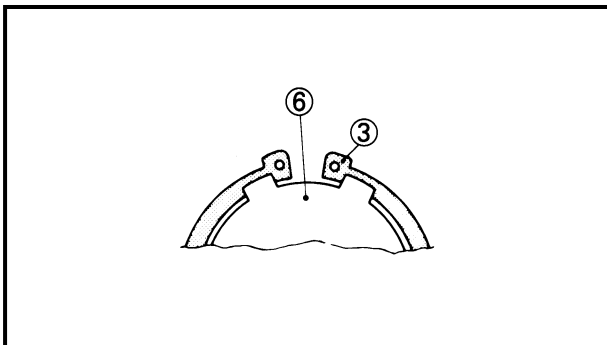

- Circlip ③

- Spline ⑥

Center the circlip ends on the spline.

Do not expand the circlip more than needed.

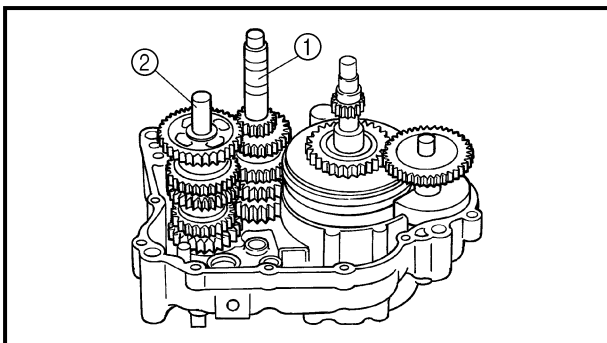

4. Install:

- Main axle assembly ①
- Drive axle assembly ②

5. Apply:

- 4-stroke engine oil
(onto shift fork guide bars)

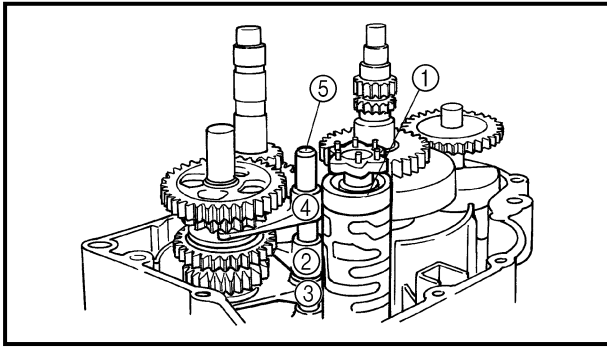

6.Install:

- Shift cam ①
- Shift fork C ②
- Shift fork L ③
- Shift fork R ④
- Shift fork guide bar ⑤

NOTE:

Install the shift forks with the embossed mark on each shift fork facing the right side of the engine.

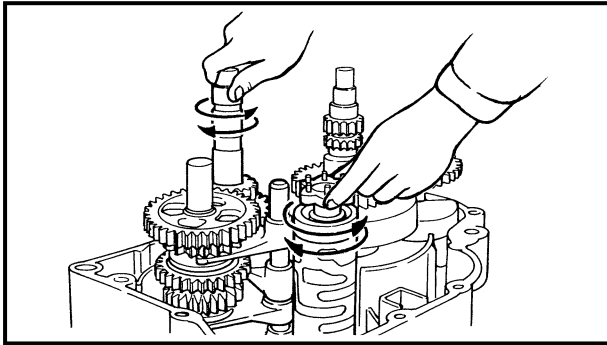

7.Check:

- Transmission operation
Unsmooth operation → Repair.

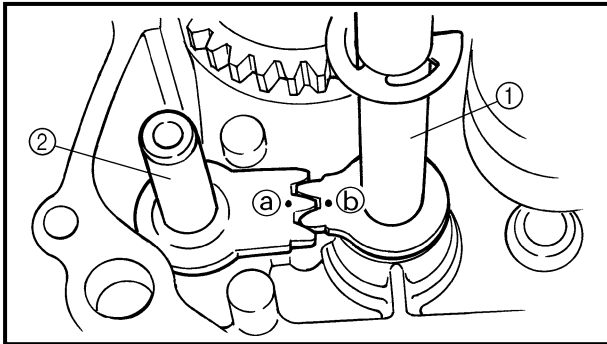

8.Install:

- Shift shaft 1 ①
- Shift shaft 2 ②

NOTE:

Mesh the shift shaft 2 mark ① with the shift shaft 1 pawl center ②.



CRANKCASE

- ① Crankcase (right)
- ② Dowel pin
- ③ Crankcase (left)
- ④ Drain bolt
- ⑤ Breather plate 2
- ⑥ Breather plate 1
- ⑦ Holder (clutch cable)
- ⑧ Breather hose

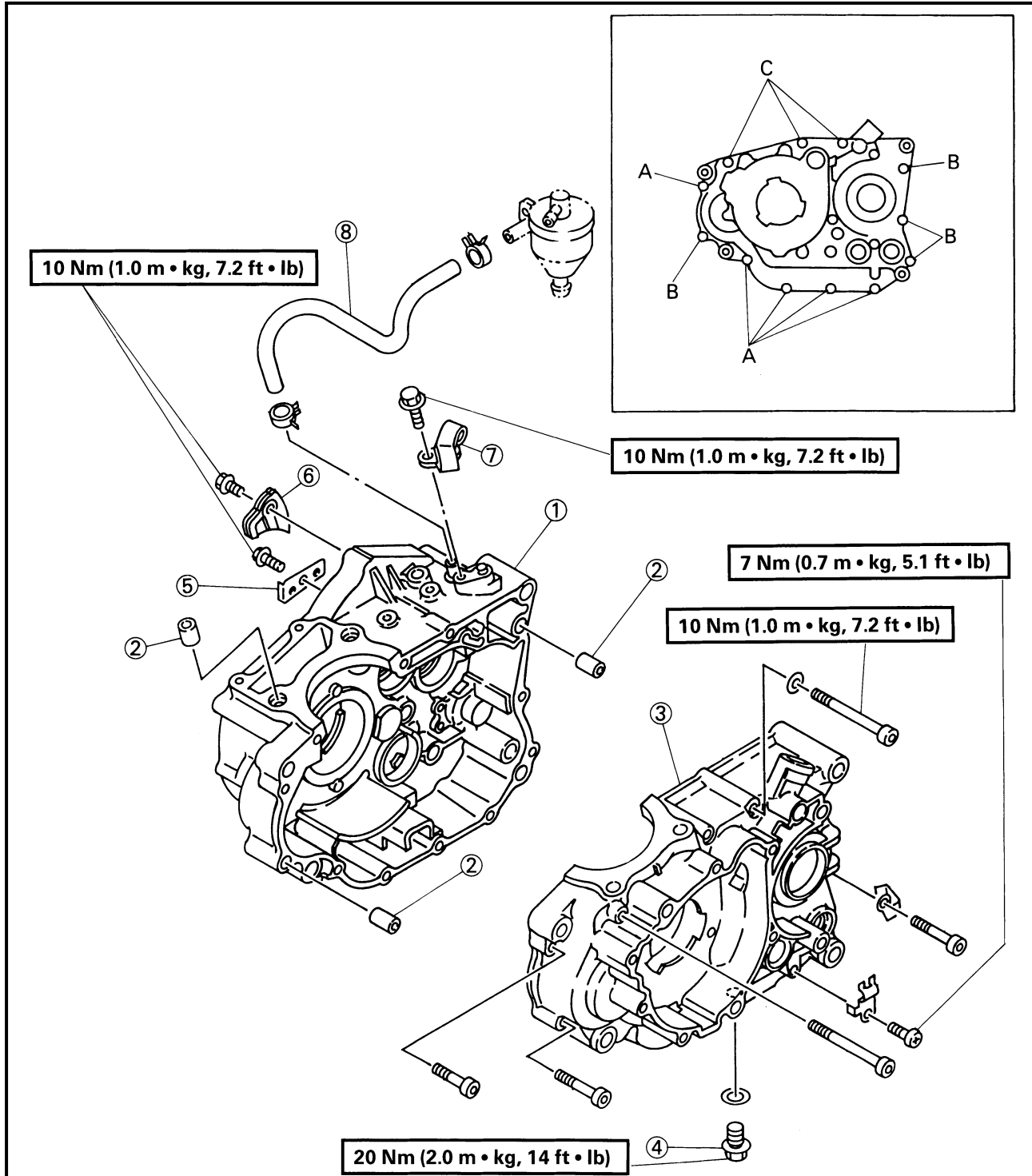

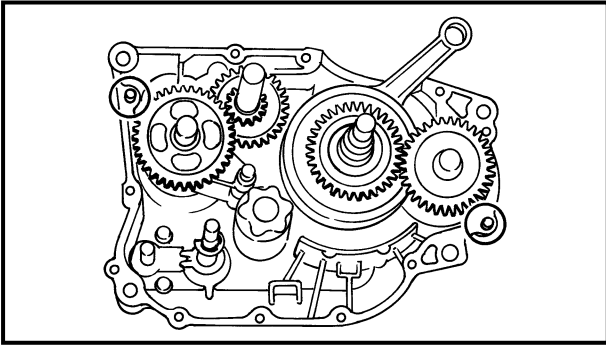

CRANKCASE (RIGHT)

1. Apply:

- Sealant
(onto mating surfaces of both case halves)



Quick Gasket®:
P/N. ACC-11001-05-01

NOTE: _____

DO NOT ALLOW any sealant to come in contact with the oil gallery.

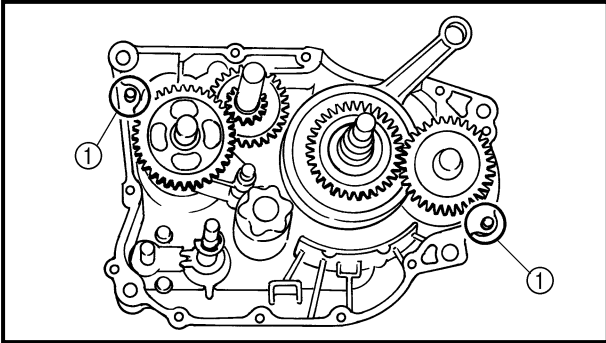

2. Install:

- Dowel pins ①
3. Fit the left crankcase onto the right case.
Tap lightly on the case with a soft hammer.

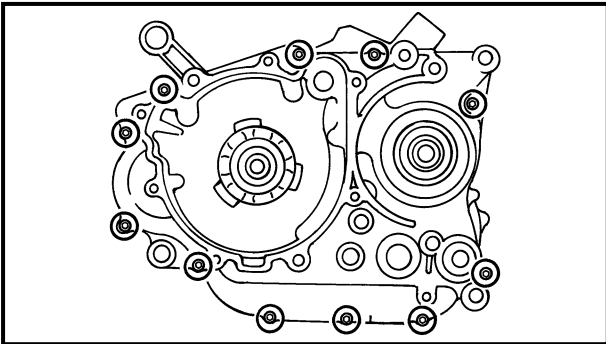

4. Tighten:

- Bolt (crankcase)



Bolt (crankcase):
10 Nm (1.0 m • kg, 7.2 ft • lb)

5. Apply:

- 4-stroke engine oil
(to the crank pin, bearing and oil delivery hole)

6. Check:

- Crankshaft and transmission operation
Unsmooth operation → Repair.

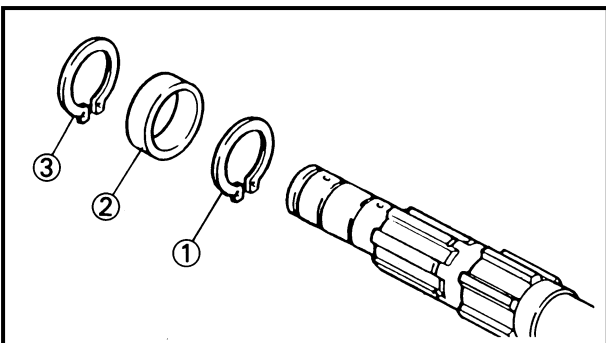

SHIFT SHAFT

1. Install:

- Circlip ① (to drive axle)
- Collar ②
- Circlip ③

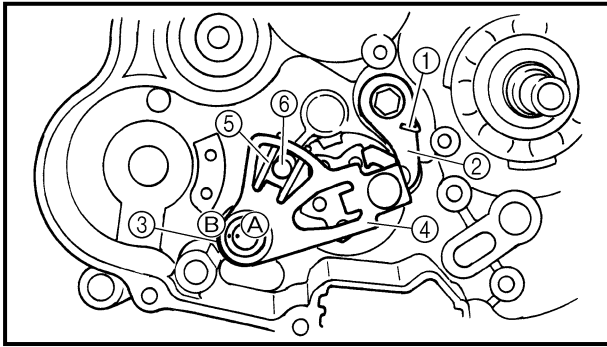
**2.Install:**

- Torsion spring ①
- Stopper lever ②
- Washer ③
- Shift lever ④
- Circlip
- Cam chain
- Cam chain damper

NOTE:

- Set the torsion spring ① and stopper lever ② at proper position.
- Install the torsion spring ⑤ fitting to the guide pin ⑥.
- Install the shift lever with the marks ④ and ⑤ aligned.



OIL PUMP

- ① Pump gear cover
- ② Pump driven gear
- ③ Pump cover
- ④ Oil pump assembly
- ⑤ Oil strainer

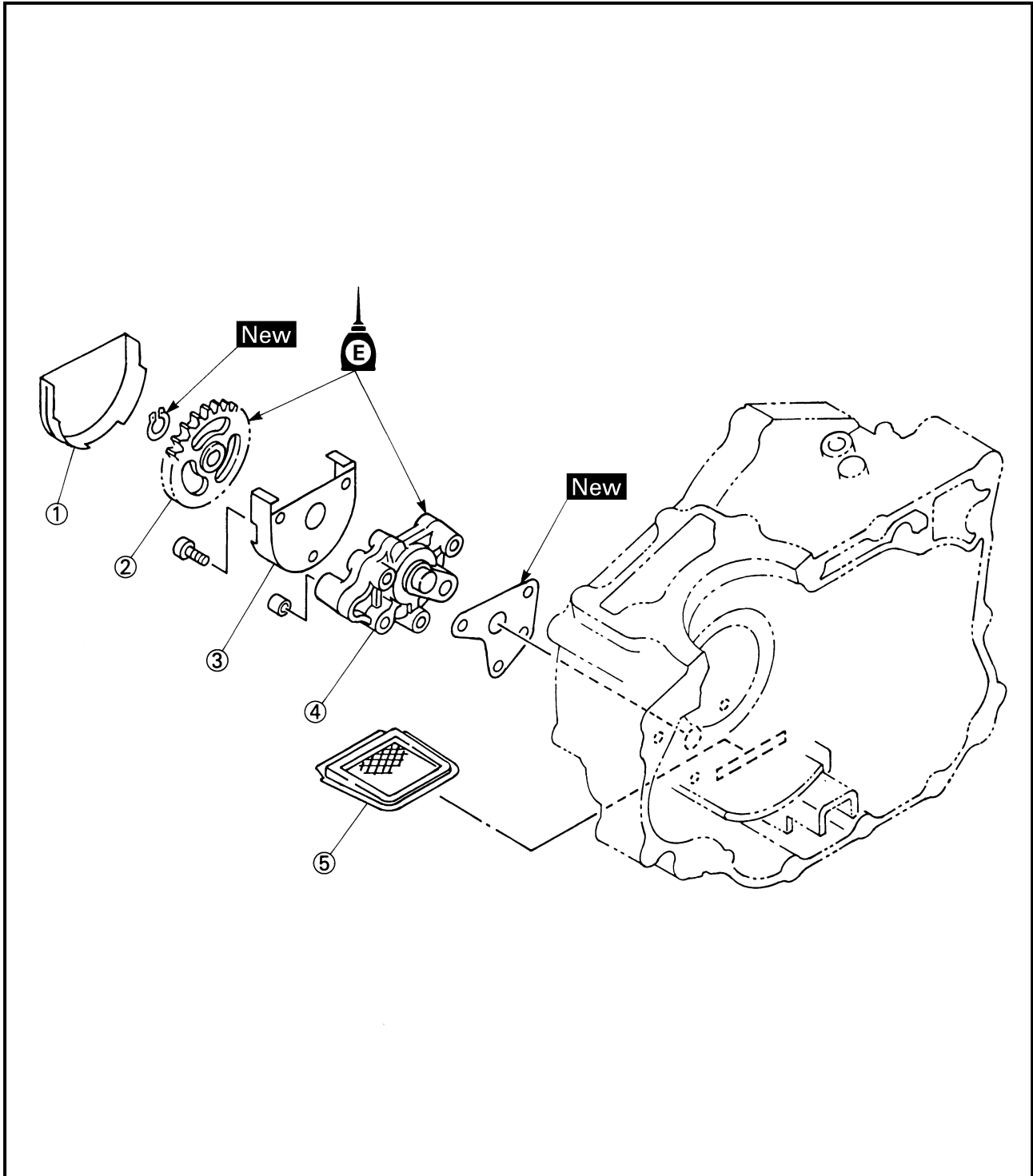



CLUTCH

- ① Clutch spring
- ② Pressure plate
- ③ Push plate
- ④ Clutch plate
- ⑤ Friction plate
- ⑥ Clutch boss
- ⑦ Thrust plate
- ⑧ Push lever
- ⑨ Push rod 2
- ⑩ Ball
- ⑪ O-ring
- ⑫ Push rod 1
- ⑬ Primary driven gear
- ⑭ Primary drive gear
- ⑮ Oil seal
- ⑯ Bearing

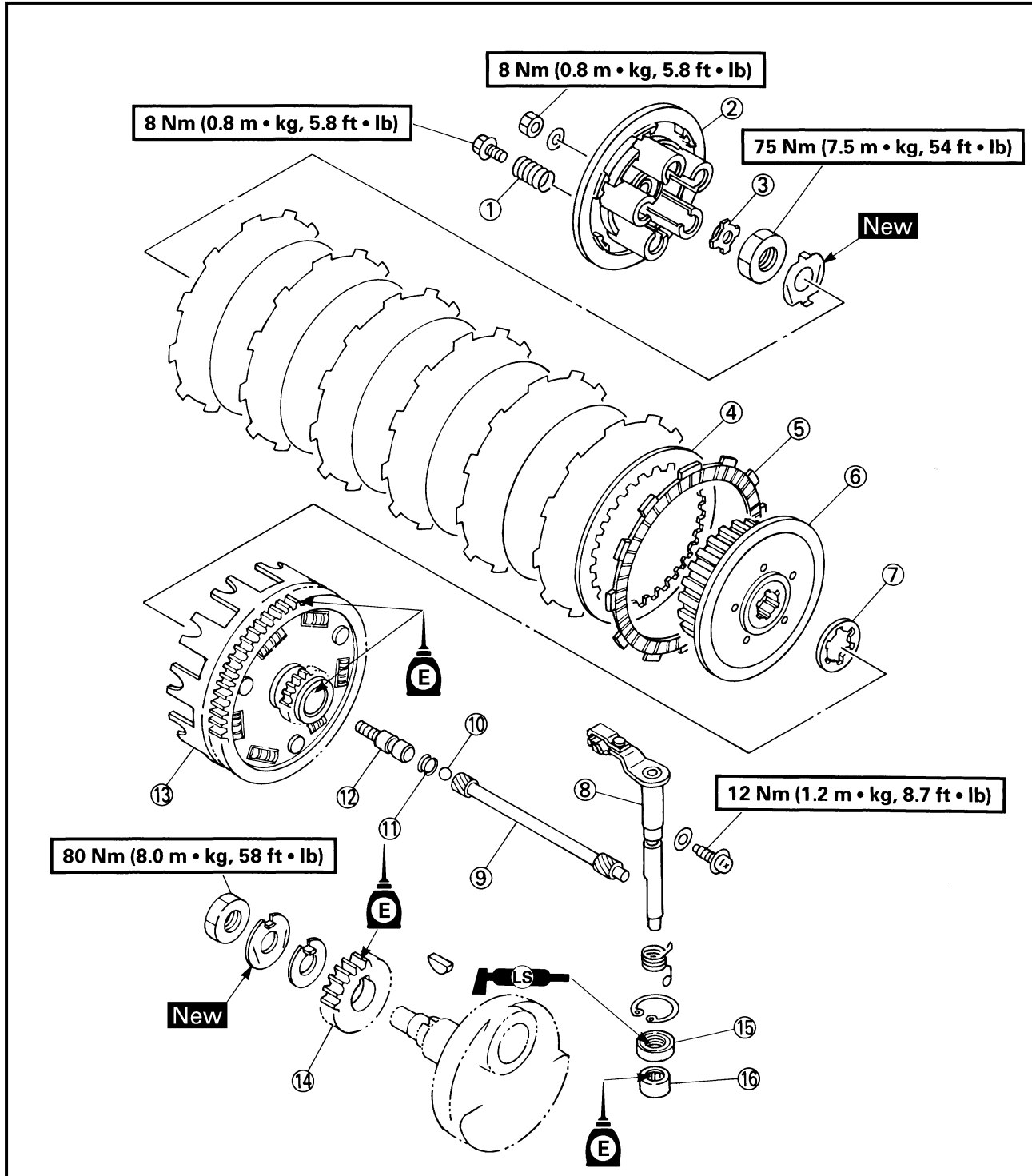

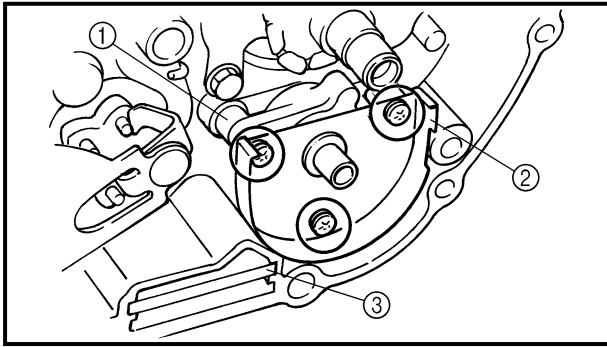

OIL PUMP

1.Install:

- Gasket
- Oil pump assembly ①
- Pump cover ②
- Oil strainer ③



Bolts (oil pump):

6 Nm (0.6 m · kg, 4.3 ft · lb)

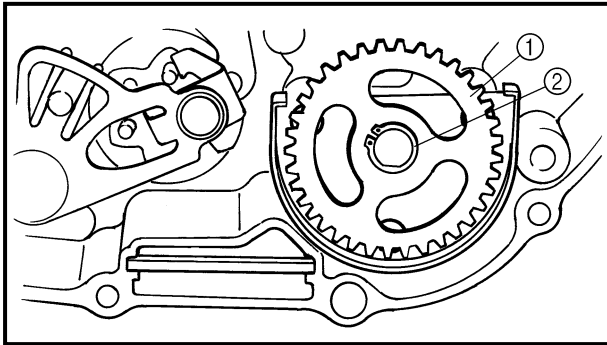

2.Install:

- Pump driven gear ①
- Circlip ②

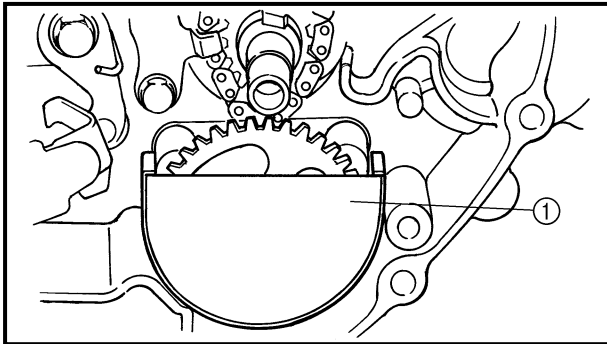

3.Install:

- Gear cover ①

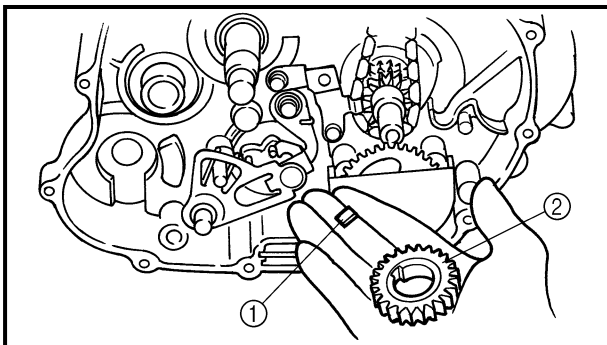

CLUTCH

1.Install:

- Key ①
- Primary drive gear ②

2.Apply:

- 4-stroke engine oil
(onto journal and gear teeth)

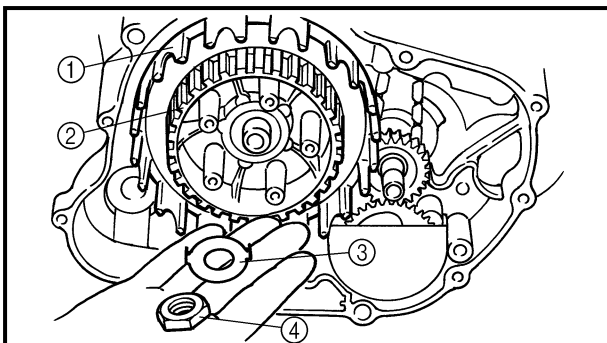

3.Install:

- Primary driven gear ①
- Thrust plate
- Clutch boss assembly ②
- Lock washer ③
- Nut ④ (clutch boss)

NOTE:

Fit the tabs of the lock washer onto the grooves of the clutch boss.

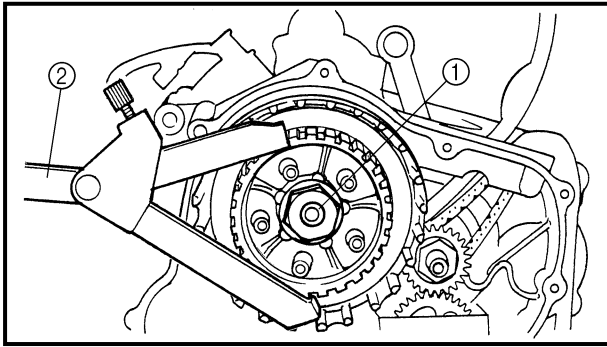

4. Tighten:
- Nut ① (clutch boss)

NOTE: Tighten the nut (clutch boss) while holding the clutch boss with the universal clutch holder ②.



Universal clutch holder:
P/N. YM-91042



Nut ① (clutch boss):
75 Nm (7.5 m • kg, 54 ft • lb)

5. Bend:
- Lock washer tabs (along nut flats)

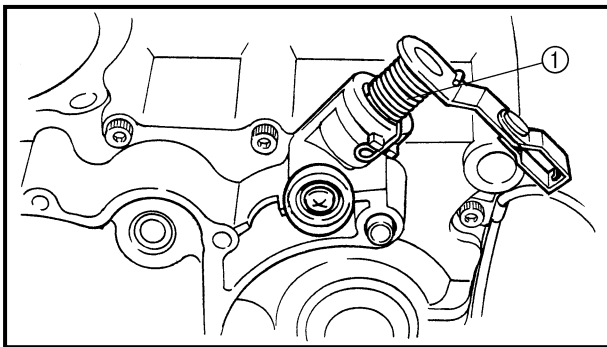

6. Install:
- Push lever assembly ①



Bolt (push lever):
12 Nm (1.2 m • kg, 8.7 ft • lb)

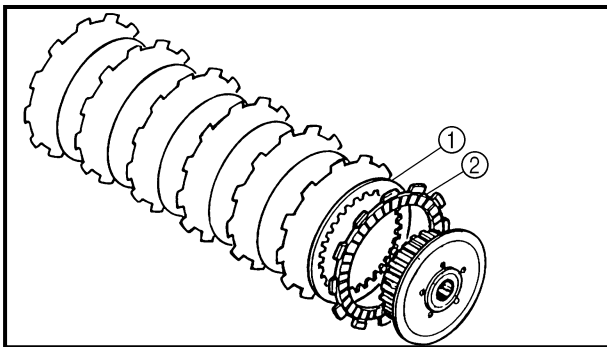

7. Install:
- Clutch plate ①
 - Friction plate ②

NOTE:

- Apply 4-stroke engine oil to the plates and install.
- Install the clutch plates and friction plates alternately on the clutch boss, starting with a friction plate and ending with a friction plate.

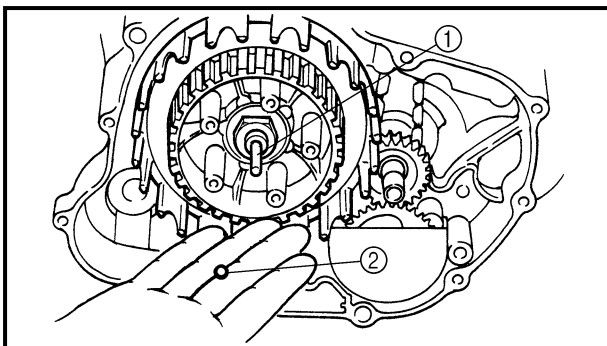

8. Install:
- Push rod 2 ①
 - Ball ②

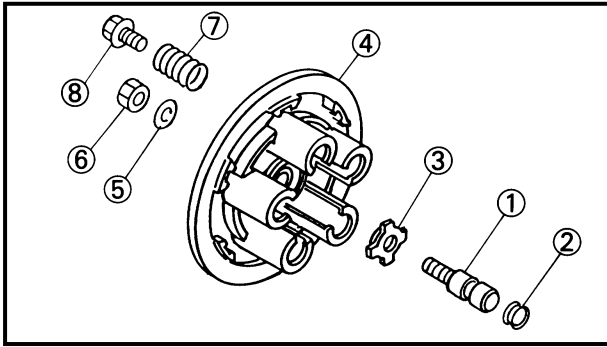

9. Install:

- Push rod 1 ①
- Push rod seal ②
- Push plate ③
- Pressure plate ④
- Plain washer ⑤
- Nut ⑥
- Spring ⑦
- Bolts ⑧

NOTE:

Tighten the bolts ⑧ in a crisscross pattern.

	<p>Bolt ⑧ (pressure plate): 8 Nm (0.8 m · kg, 5.8 ft · lb)</p>
---	---

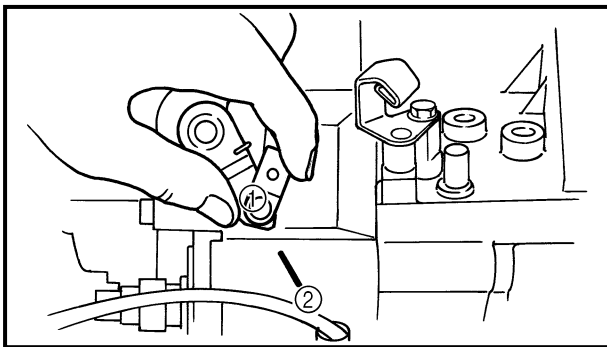

10. Check:

- Push lever position
 Push the push lever assembly in the direction of the arrow and make sure that the match marks are aligned.
 Not aligned → Adjust.
- ① Match mark on the push lever assembly
- ② Match mark on the crankcase

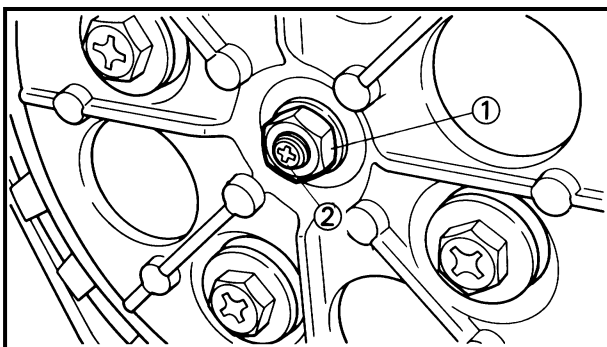

11. Adjust:

- Push lever position
- *****
- Adjustment steps:**
- Loosen the locknut ①.
 - Turn the adjuster ② clockwise or counter-clockwise until both match marks are aligned.
 - Hold the adjuster to prevent it from moving and thoroughly tighten the locknut.

Do not overtighten the adjuster ②, as this may eliminate the necessary free play between the push rods.

	<p>Locknut ① (push rod 1): 8 Nm (0.8 m · kg, 5.8 ft · lb)</p>
---	--

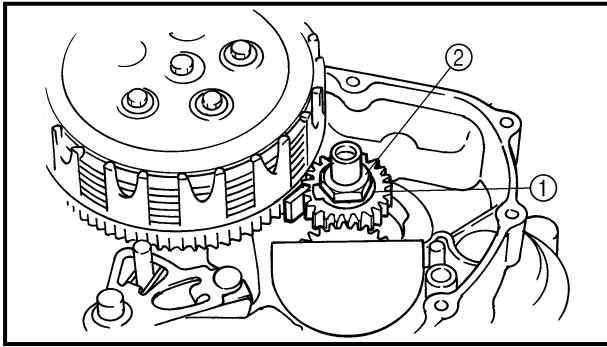

12. Install:
- Claw washer
 - Lock washer ①
 - Nut ②

NOTE:

- Place a folded rag or aluminum plate between the teeth of the drive gear and primary driven gear.
- Take care not to damage the gear teeth.

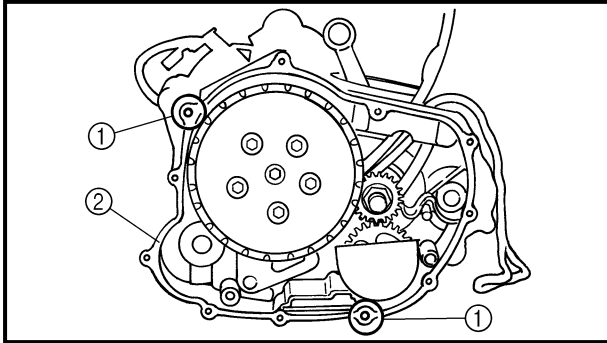

13. Bend the lock washer tab along the nut flats.

14. Install:
- Dowel pin ①
 - Gasket ② (crankcase cover)

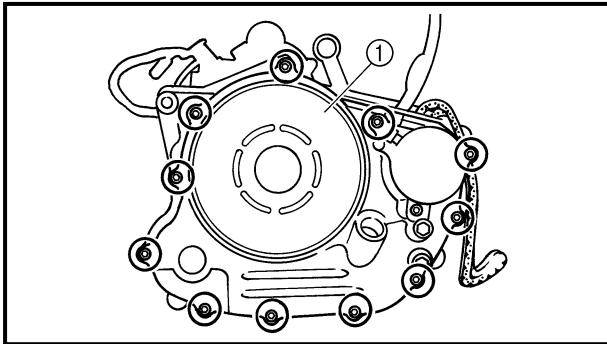

15. Install:
- Crankcase cover ① (right)

	<p>Bolt (crankcase cover): 10 Nm (1.0 m • kg, 7.2 ft • lb)</p>
--	---

NOTE:

Tighten the bolts (crankcase cover) in a criss-cross pattern.

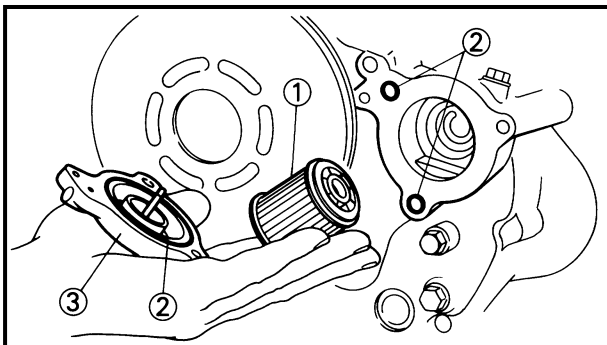

OIL FILTER

1. Apply:
- 4-stroke engine oil (to the oil filter and into the oil passage)
2. Install:
- Oil filter ①
 - O-rings ②
 - Oil filter cover ③

	<p>Bolt (oil filter cover): 10 Nm (1.0 m • kg, 7.2 ft • lb)</p>
---	--

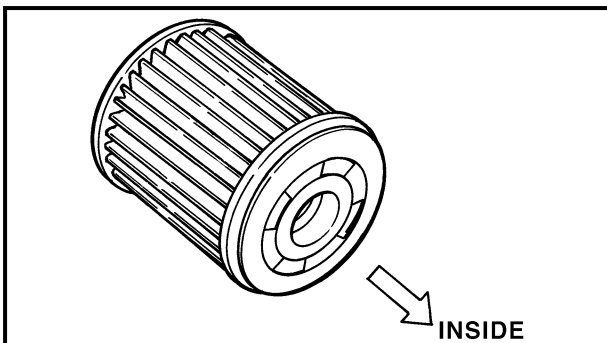

Install the oil filter as shown.



ROTOR AND STARTER DRIVES

- ① Starter idle gear 1
- ② Bearing
- ③ Shaft 1
- ④ Bearing
- ⑤ Washer
- ⑥ Starter idle gear 2
- ⑦ Bearing
- ⑧ Plate washer
- ⑨ Bearing
- ⑩ Starter wheel gear
- ⑪ Starter clutch
- ⑫ Rotor
- ⑬ Stator coil
- ⑭ Clamp

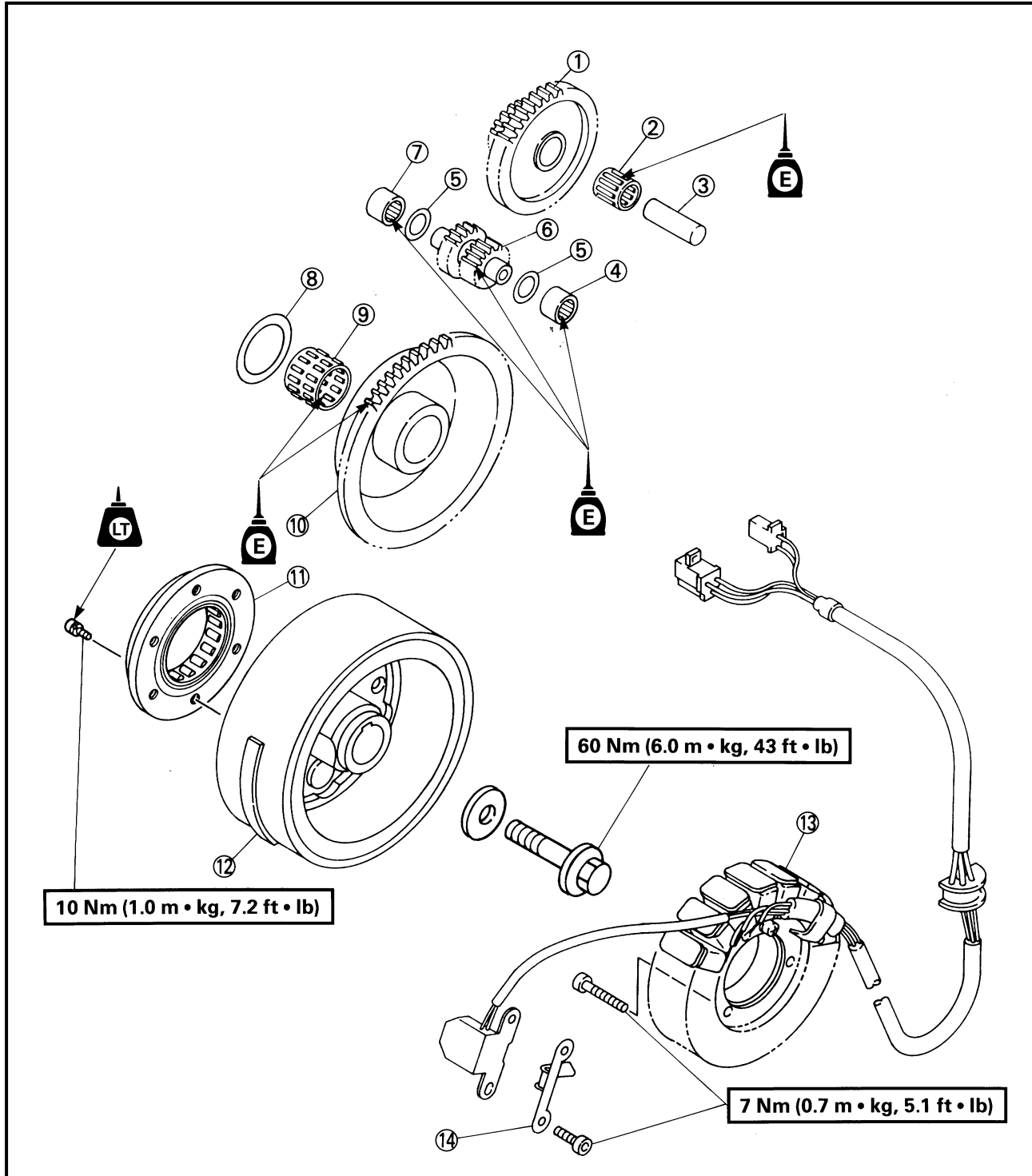



ROTOR AND STARTER DRIVES

NOTE: _____

Fasten a safety wire to the timing chain to prevent it from falling into the crankcase.

1. Apply:

- 4-stroke engine oil
(onto journal and starter drives)

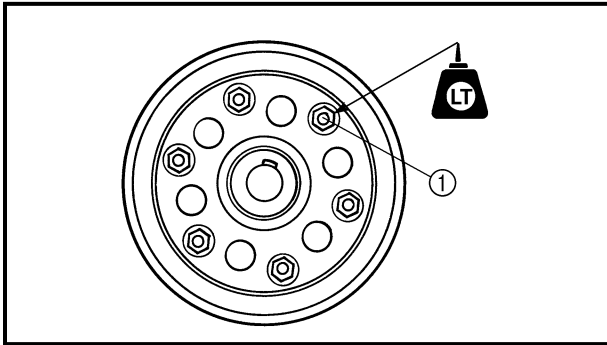

2. Install:

- Starter clutch
- Bolt ①

	<p>Bolt ① (Starter clutch): 10 Nm (1.0 m · kg, 7.2 ft · lb)</p>
--	--

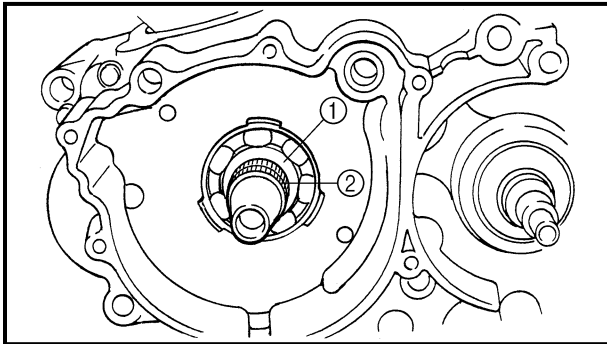

3. Install:

- Plain washer ①
- Bearing ②

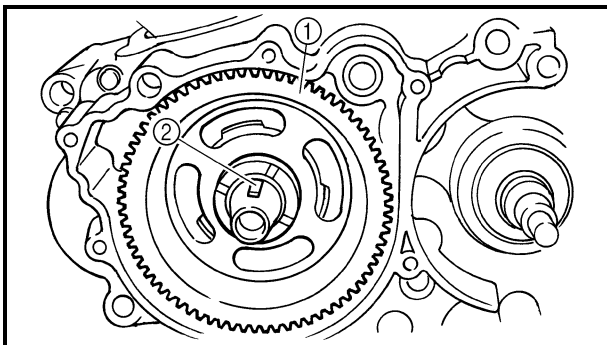

4. Install:

- Starter wheel gear ①
- Woodruff key ②

5. Install:

- Rotor

NOTE: _____

Temporarily install the rotor aligning the key way of the rotor with the woodruff key. Turn the starter wheel gear clockwise and install the rotor to starter wheel gear.

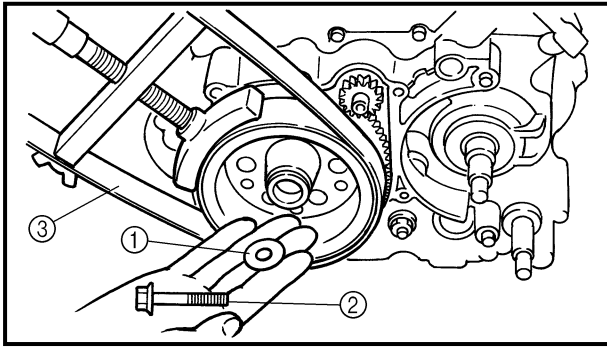

6.Install:

- Washer ①
- Bolt ②



Bolt ② (rotor):
60 Nm (6.0 m • kg, 43 ft • lb)

NOTE: _____

Tighten the bolt (rotor) while holding the rotor with the sheave holder ③.



Sheave holder:
P/N. YS-01880

CA _____

Do not allow the rotor holder to touch the projections on the rotor.

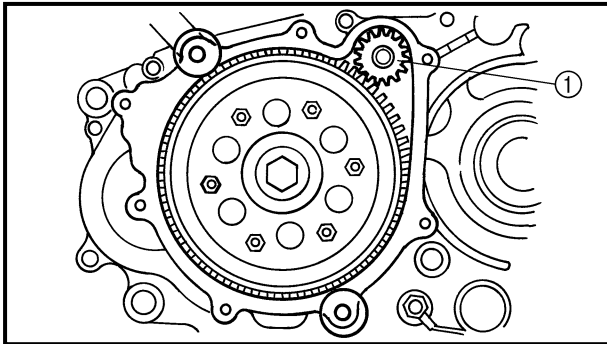

7.Install:

- Dowel pins
- Gasket (crankcase cover)
- Washers (idle gear 2)
- Idle gear 2 ①

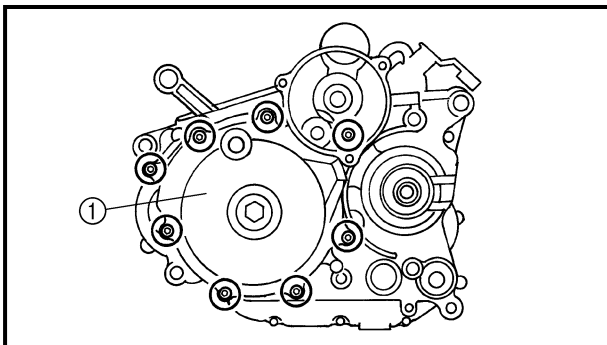

8.Install:

- Crankcase cover 1 ①



Bolt (crankcase cover 1):
10 Nm (1.0 m • kg, 7.2 ft • lb)

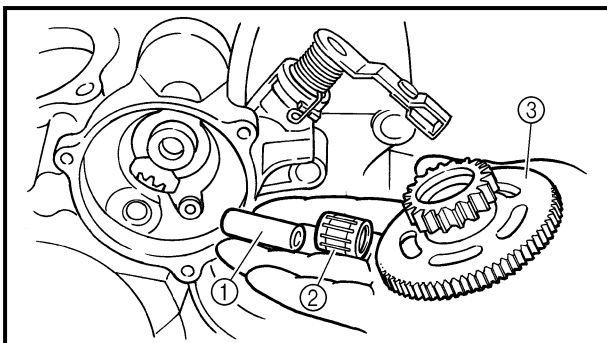

9.Install:

- Shaft ①
- Bearing ②
- Starter idle gear 1 ③
- Generator cover



Bolt (generator cover):
10 Nm (1.0 m • kg, 7.2 ft • lb)



CYLINDER AND PISTON

- ① Cylinder
- ② Dowel pin
- ③ O-ring
- ④ Cylinder gasket
- ⑤ Piston ring
- ⑥ Piston pin clip
- ⑦ Piston
- ⑧ Piston pin

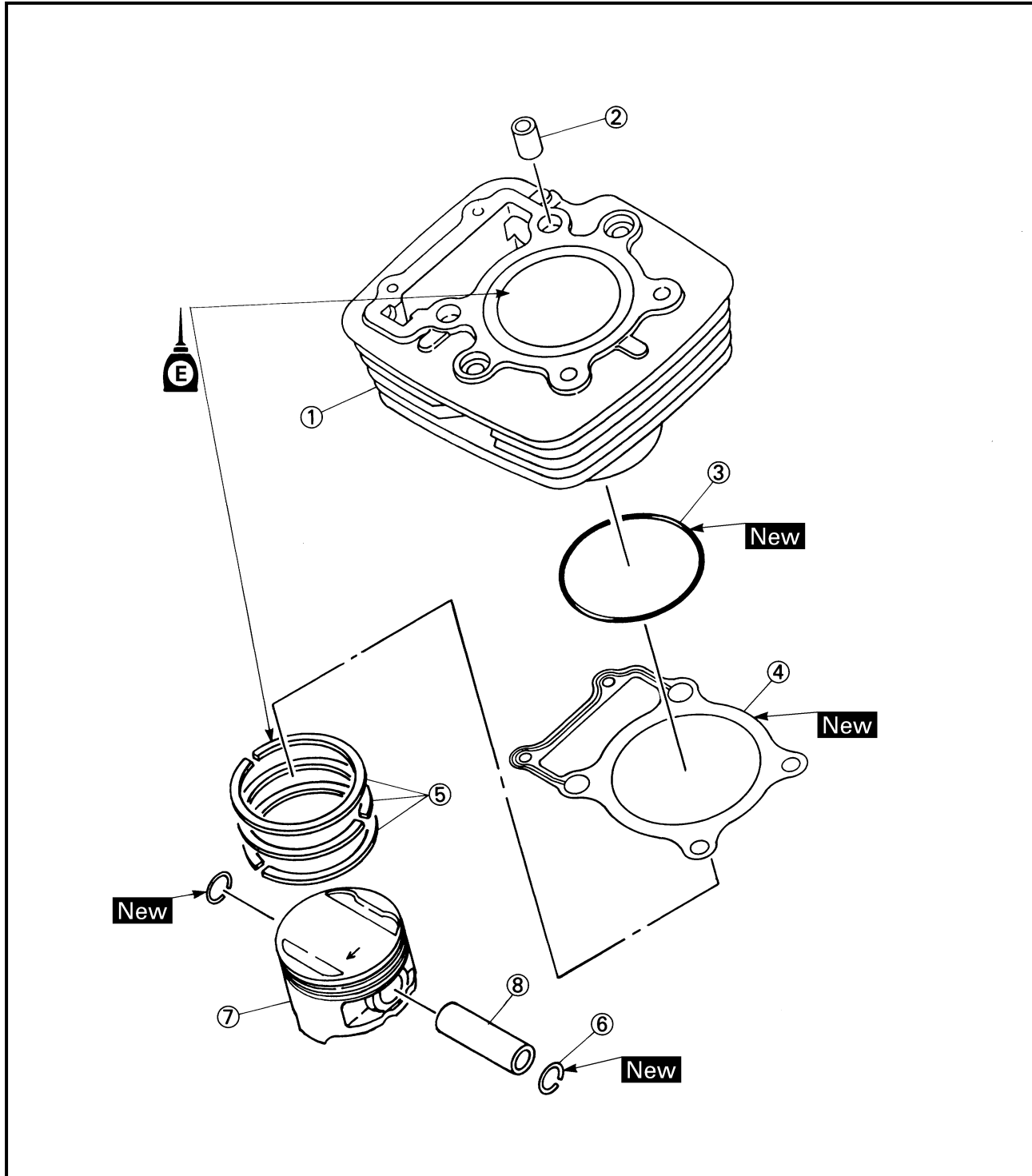

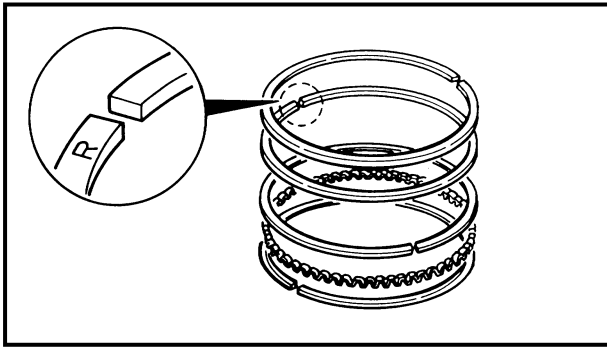

CYLINDER AND PISTON

1. Apply:

- 4-stroke engine oil
(onto piston rings and piston pins)

2. Install:

- Piston rings

NOTE:

Be sure to install the rings so that manufacturer's marks or numbers are located on the top side of the rings.

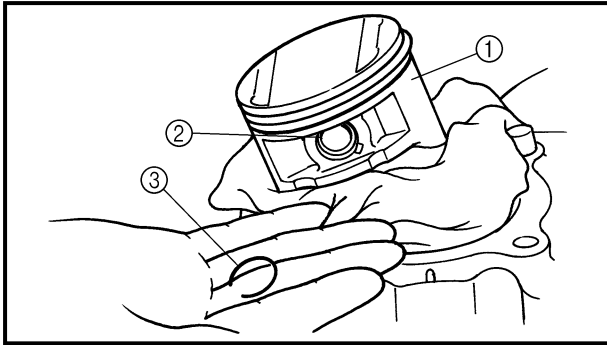

3. Install:

- Piston ①
- Piston pin ②
- Piston pin clip ③

NOTE:

- The arrow ④ on the piston must point to the front of the engine.
- Before installing the piston pin clip, cover the crankcase with a clean towel or rag so you will not accidentally drop the piston pin clip and material into the crankcase.

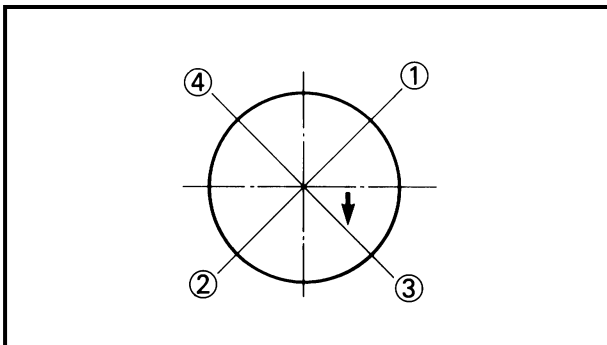
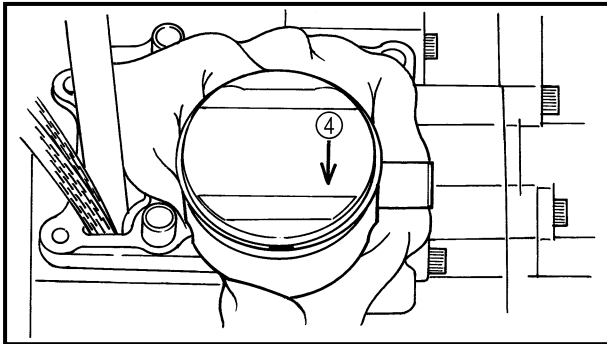

4. Position:

- Top ring
 - 2nd ring
 - Oil rings
- Offset the piston ring end gaps as shown.

- ① Top ring end
- ② Oil ring end (lower)
- ③ Oil ring end (upper)
- ④ 2nd ring end

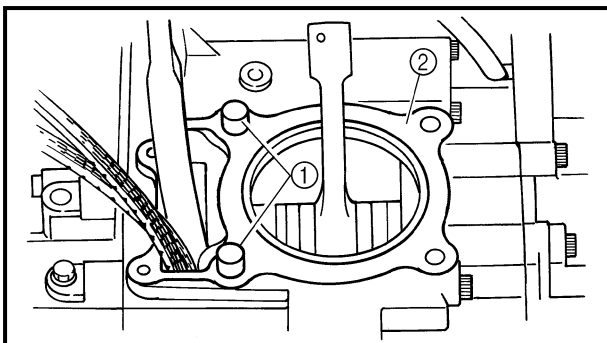

5. Install:

- Dowel pins ①
- Gasket ② (cylinder)

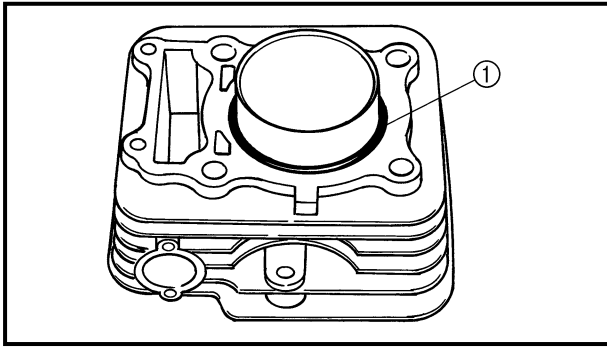

- 6.Install:
- O-ring ①

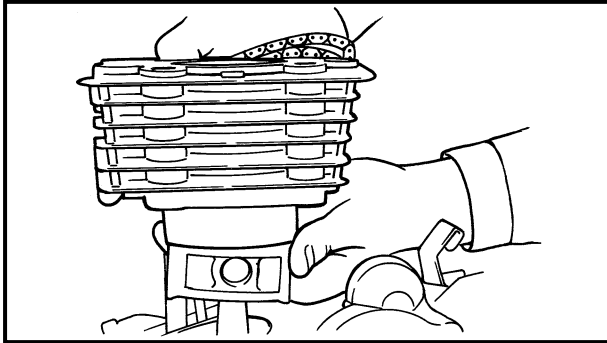

- 7.Install:
- Cylinder

NOTE: _____
 Install the cylinder with one hand while
 compressing the piston ring with the other
 hand.

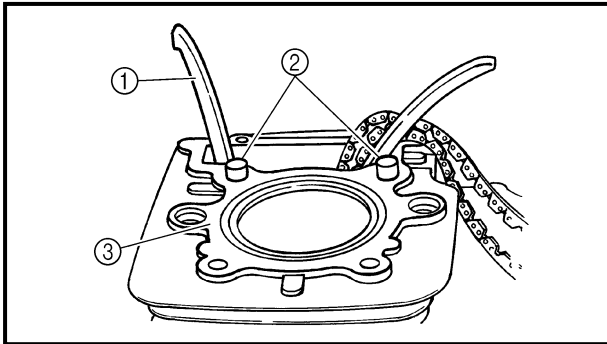

- 8.Install:
- Timing chain guide ① (exhaust)
 - Dowel pins ②
 - Gasket ③ (cylinder head)



CYLINDER HEAD

- ① Mount rubber
- ② Cylinder head cover gasket
- ③ Cylinder head assembly
- ④ Camshaft cap
- ⑤ Camshaft cap
- ⑥ Dowel pin
- ⑦ Circlip
- ⑧ Valve guide
- ⑨ Spark plug
- ⑩ Cylinder head gasket

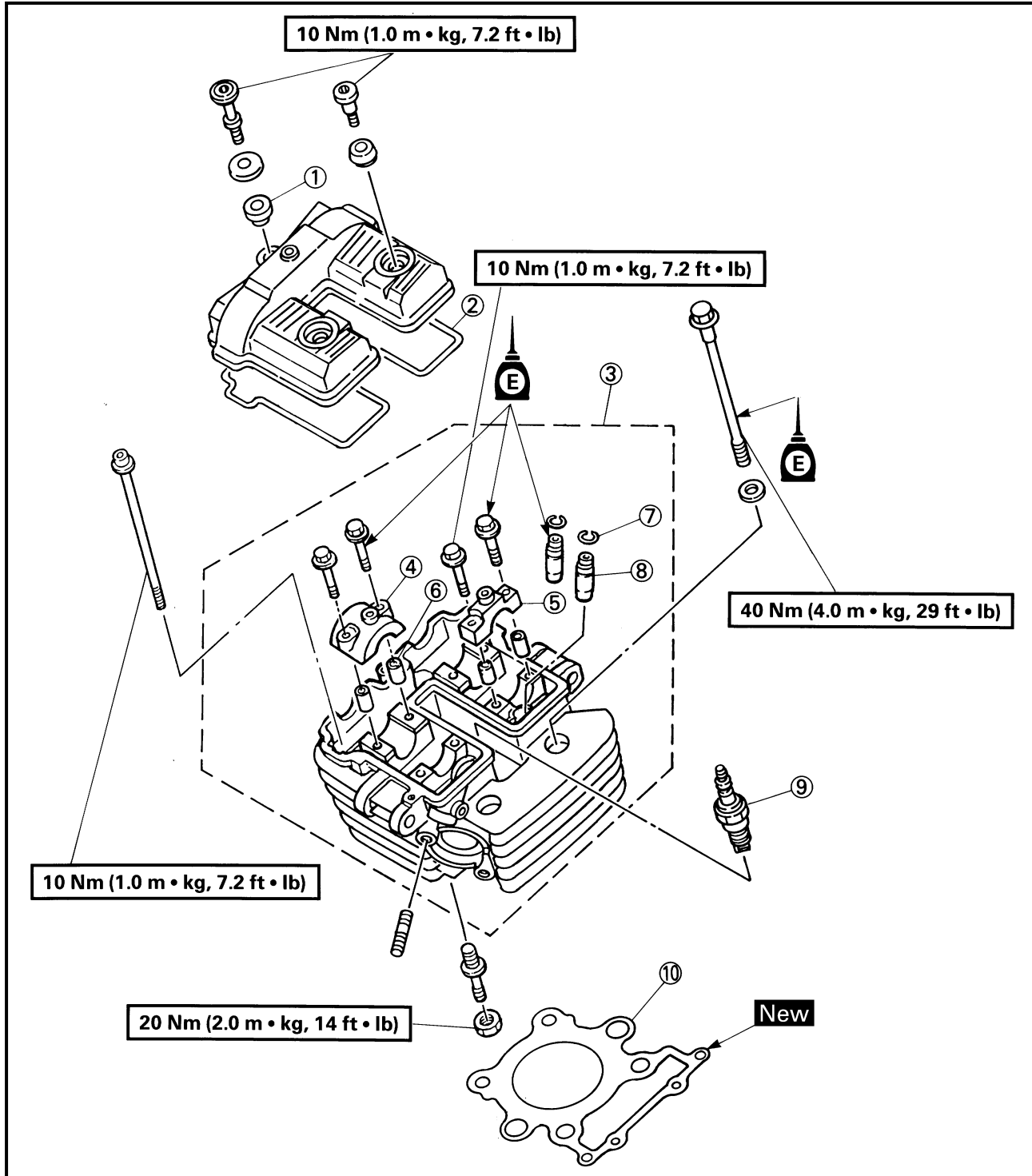



VALVE, CAMSHAFT AND CAM CHAIN

- | | |
|--------------------------------|-------------------|
| ① Timing chain guide (intake) | ⑩ Adjusting pad |
| ② Camshaft (intake) | ⑪ Valve cotter |
| ③ Camshaft (exhaust) | ⑫ Valve retainer |
| ④ Cam sprocket | ⑬ Oil seal |
| ⑤ Timing chain | ⑭ Valve spring |
| ⑥ Timing chain guide (exhaust) | ⑮ Spring seat |
| ⑦ Stopper guide | ⑯ Valve (intake) |
| ⑧ Timing chain tensioner | ⑰ Valve (exhaust) |
| ⑨ Valve lifter | |

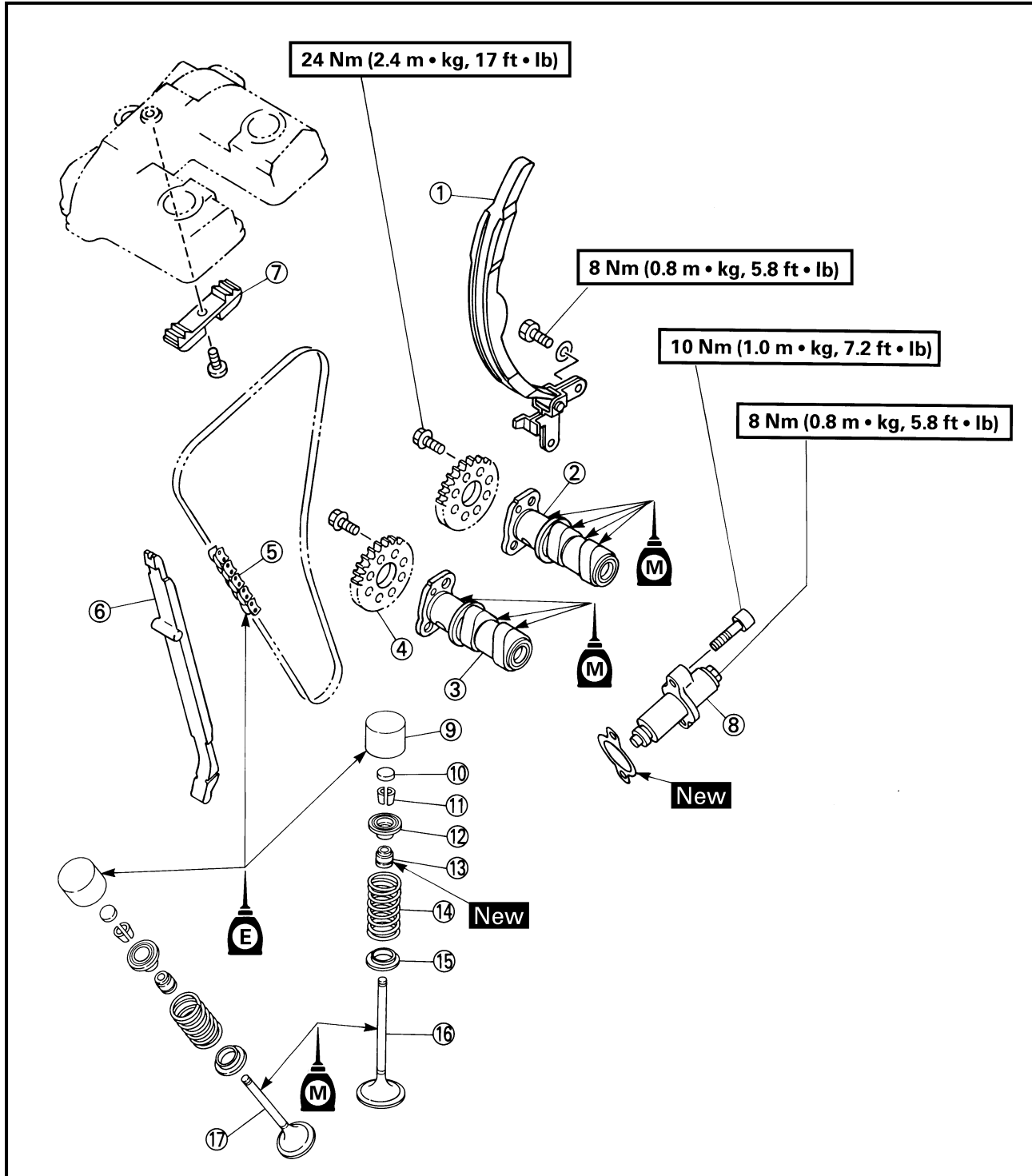

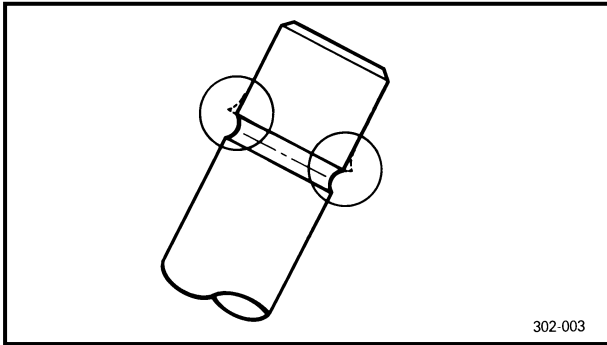

VALVE AND CAMSHAFT

1. Deburr:

- Valve stem end
Use an oil stone to smooth the stem end.

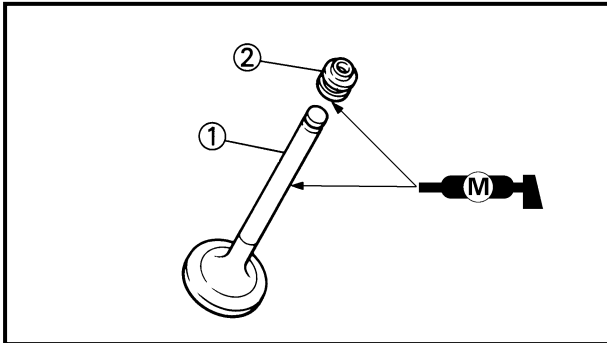

2. Apply:

- Molybdenum disulfide oil
(onto valve stem ① and oil seal ②)

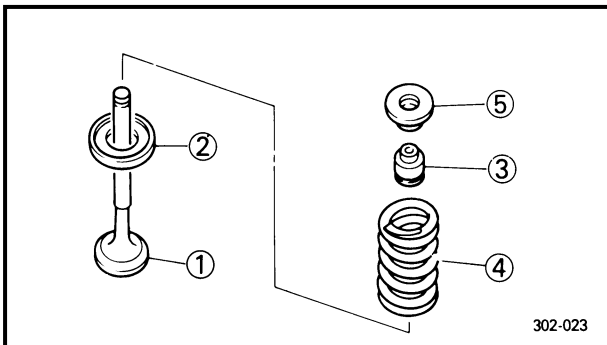

3. Install:

- Valve ①
- Spring seat ②
- Oil seal ③
- Valve spring ④
- Valve retainer ⑤
(into cylinder head)

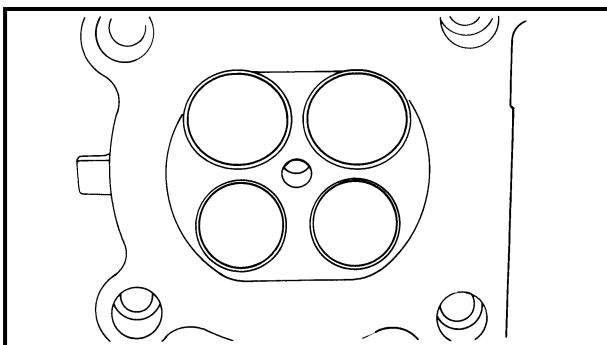

NOTE:

- Make sure that each valve is installed in its original place.
- Install the valve spring with the larger pitch ① facing upwards.

② Smaller pitch

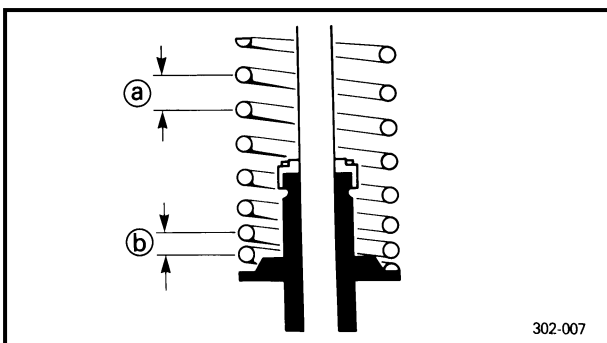

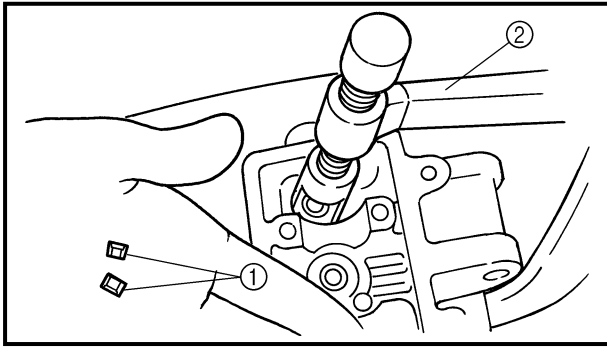

4. Install:

- Valve cotters ①

NOTE: _____

Install the valve cotters while compressing the valve spring with the valve spring compressor ②.



Valve spring compressor:
P/N. YM-04019

5. Secure the valve cotters onto the valve stem by tapping lightly with a piece of wood.

NOTE: _____

Do not hit so much as to damage the valve.

6. Apply:

- Molybdenum disulfide oil
(onto outer surface of valve lifters and pads)

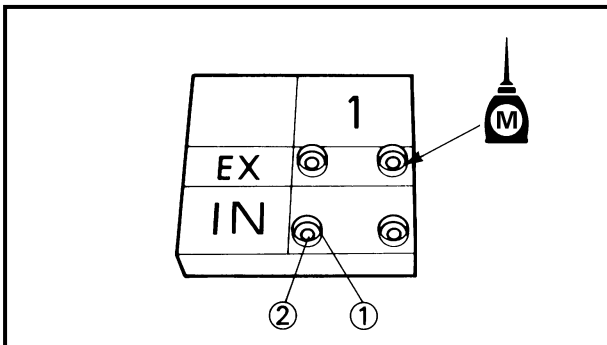

7. Install:

- Valve lifters ①
- Pads ②

NOTE: _____

- When rotated with a finger, the valve lifter should move smoothly.
- Identify each lifter and pad position very carefully so that they can be reinstalled in their original place.

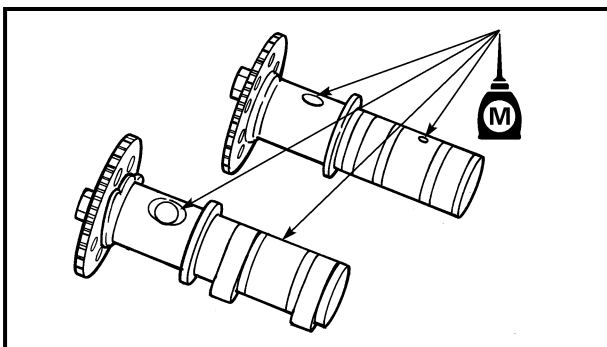

8. Apply:

- Molybdenum disulfide oil
(onto camshaft journal)

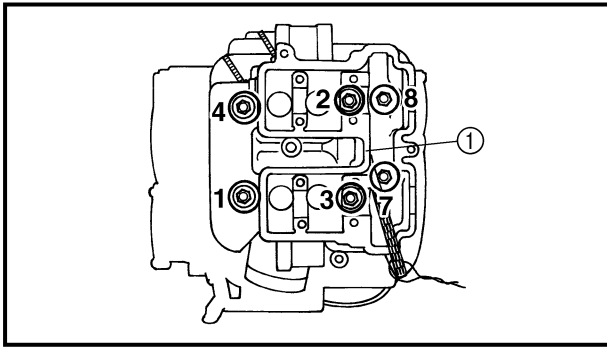

CYLINDER HEAD

1.Install:

- Cylinder head ①

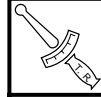

Bolts ① ~ ④ (cylinder head):
40 Nm (4.0 m · kg, 29 ft · lb)
Nuts ⑤, ⑥ (cylinder head):
20 Nm (2.0 m · kg, 14 ft · lb)
Bolts ⑦, ⑧ (cylinder head):
10 Nm (1.0 m · kg, 7.2 ft · lb)

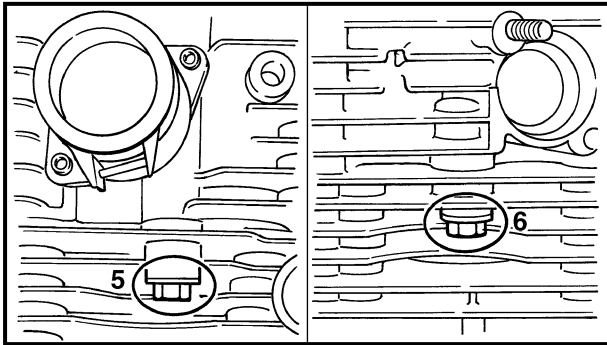

NOTE:

- Apply engine oil onto the nut threads.
- Tighten the nuts in a crisscross pattern.

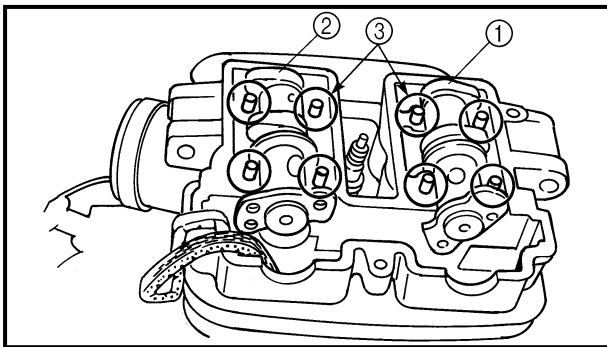

2.Install:

- Exhaust camshaft ①
- Intake camshaft ②
- Dowel pins ③

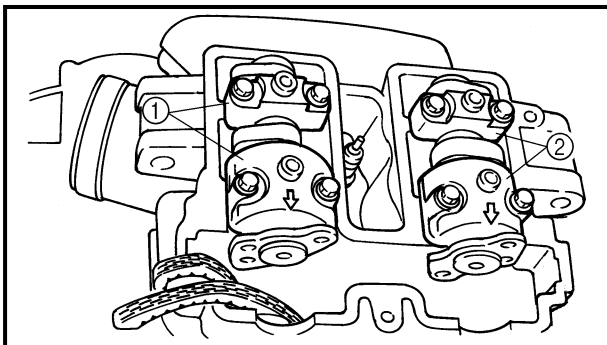

3.Install:

- Camshaft caps ① (intake camshaft)
- Camshaft caps ② (exhaust camshaft)

NOTE:

Install the camshaft cap with the arrow mark embossed facing right side of the engine.

4.Tighten:

- Bolts (camshaft caps)

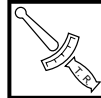

Bolt (camshaft caps):
10 Nm (1.0 m · kg, 7.2 ft · lb)

NOTE:

Tighten the bolts (camshaft caps) in a criss-cross pattern from inner most to outer caps.



The bolts (camshaft caps) must be tightened evenly or damage to the cylinder head, camshaft caps and camshaft will result.

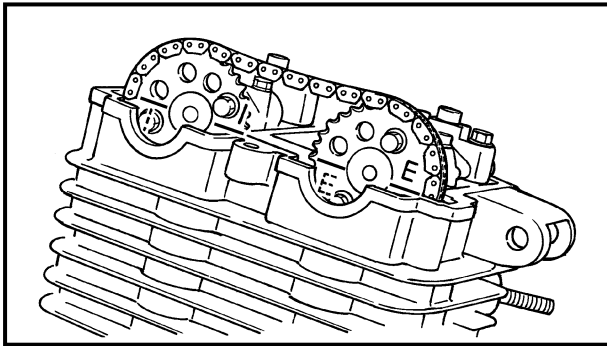
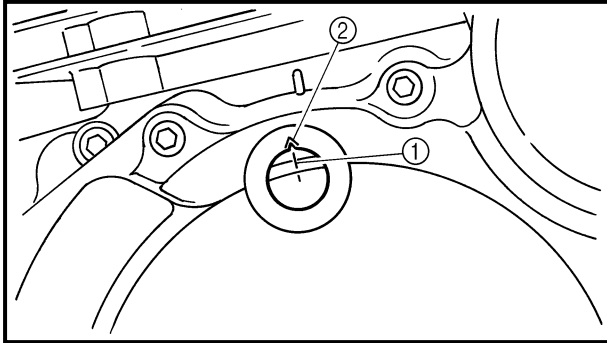

5.Install:

- Cam sprockets

Installing steps:

- Turn the crankshaft clockwise until the TDC mark ① is aligned with the stationary pointer ②.
- Fit the timing chain onto both cam sprockets and install the cam sprockets on the camshafts.

NOTE:

When installing the cam sprockets, start with the exhaust camshaft to keep the timing chain as tense as possible on the exhaust side, and set the respective match marks to be parallel with the case surface on the corresponding sides.

"I" : Intake side

"E" : Exhaust side

Do not turn the crankshaft during the camshafts installation. Damage or improper valve timing will result.

- While holding the camshafts, temporarily tighten the bolts.

6.Install:

- Timing chain tensioner

Installation steps:

- While pressing the tensioner rod lightly with fingers, use a thin screwdriver ① and wind the tensioner rod up fully clockwise.

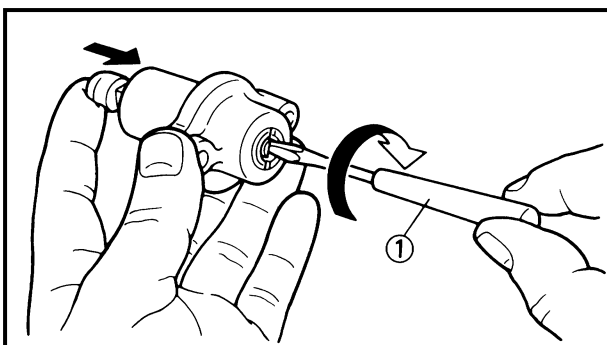

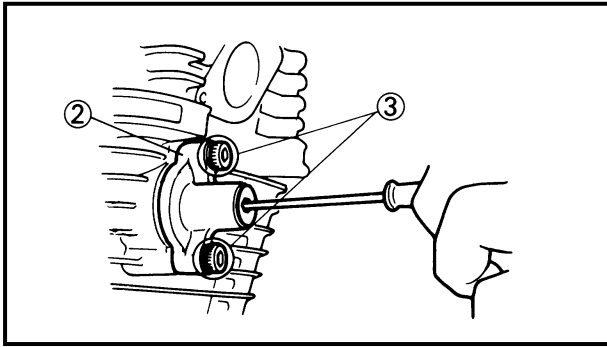

- With the rod fully wound, install the gasket and the chain tensioner (2), and tighten the bolts (3) to the specified torque.

	Bolt (3) (chain tensioner): 10 Nm (1.0 m · kg, 7.2 ft · lb)
---	--

- Release the screwdriver, check if the tensioner rod comes out and tighten the gasket and the cap bolt to the specified torque.

	Cap bolt (timing chain tensioner): 8 Nm (0.8 m · kg, 5.8 ft · lb)
---	--

7.Check:

- Valve timing
Incorrect timing → Adjust.
Refer to above steps 4 ~ 6.

8.Check:

- Valve clearance
Out of specification → Adjust.
Refer to "VALVE CLEARANCE ADJUSTMENT" in CHAPTER 3.

	Intake valve (cold): 0.09 ~ 0.17 mm (0.004 ~ 0.007 in) Exhaust valve (cold): 0.19 ~ 0.27 mm (0.007 ~ 0.011 in)
---	---

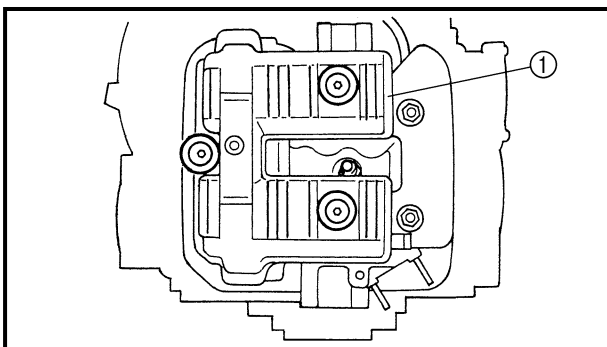

9.Install:

- Cylinder head cover (1)

	Bolt (cylinder head): 10 Nm (1.0 m · kg, 7.2 ft · lb)
---	--

10.Install:

- Timing plug
- Plug

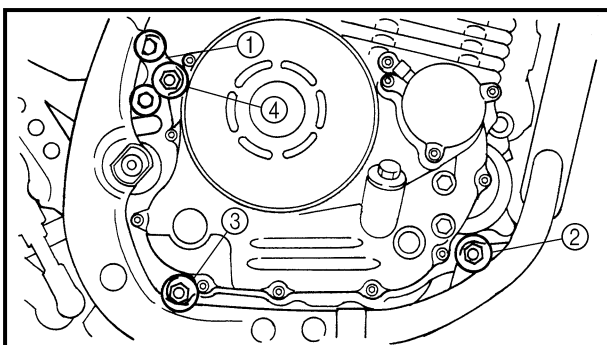

REMounting ENGINE

When remounting the engine, reverse the removal procedure. Note the following points.

1.Install:

- Bracket 1 (1)
- Mounting bolt (front-lower) (2)
- Mounting bolt (rear-lower) (3)
- Mounting bolt (rear-upper) (4)



NOTE:

Install all the bolts and nuts first, and then tighten the bolts and nuts to specifications.



Bracket bolts:

23 Nm (2.3 m • kg, 17 ft • lb)

Mounting bolts:

64 Nm (6.4 m • kg, 46 ft • lb)

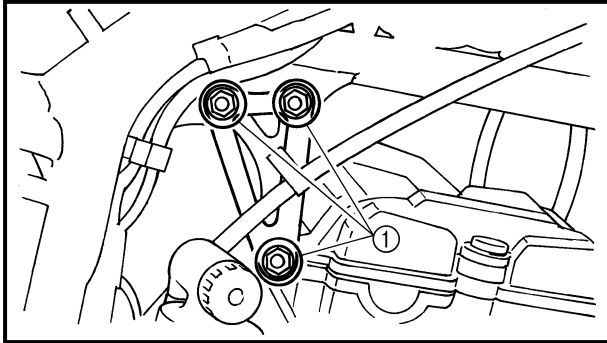

2. Tighten:

- Bolt ①



Stay bolts (cylinder head-stay):

64 Nm (6.4 m • kg, 46 ft • lb)

Stay bolts (stay-frame):

30 Nm (3.0 m • kg, 22 ft • lb)

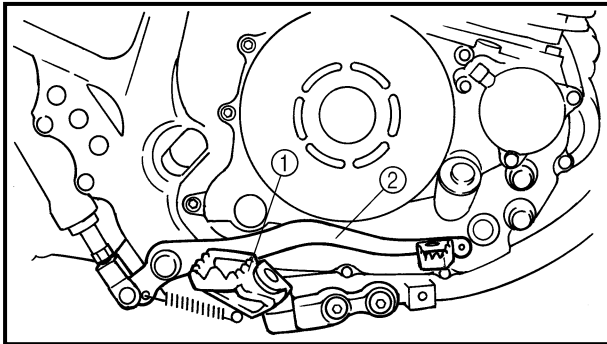

3. Install:

- Brake pedal ①
- Footrest (right) ②

Refer to "ENGINE REMOVAL".



Bolt (brake pedal):

19 Nm (1.9 m • kg, 13 ft • lb)

Bolt (footrest):

64 Nm (6.4 m • kg, 46 ft • lb)

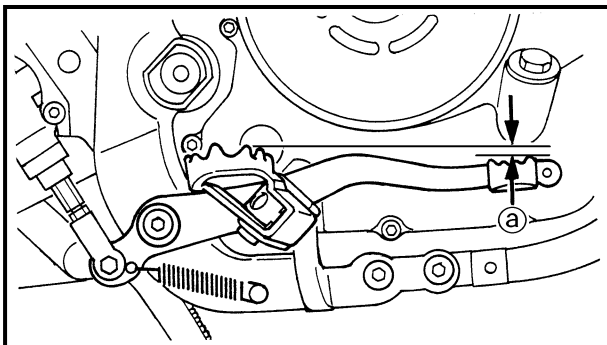

4. Adjust:

- Brake pedal height ③

Refer to "REAR BRAKE ADJUSTMENT" in CHAPTER 3.



Brake pedal height:

10 mm (0.39 in)

Below top of footrest

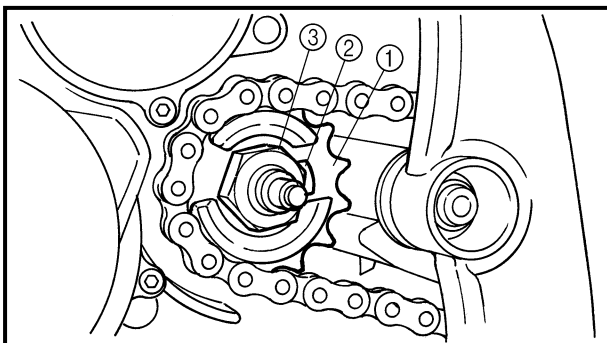

5. Install:

- Drive chain (with drive sprocket) ①
- Lock washer ②
- Nut ③

Refer to "ENGINE REMOVAL".



Nut ③:

110 Nm (11.0 m • kg, 80 ft • lb)

⚠ WARNING

Use a new lock washer.



6. Bend:

- Lock washer tabs
(along nut flats)

7. Adjust:

- Drive chain slack
Refer to "DRIVE CHAIN SLACK ADJUSTMENT" in CHAPTER 3.



Drive chain slack:
35 ~ 50 mm (1.38 ~ 1.97 in)

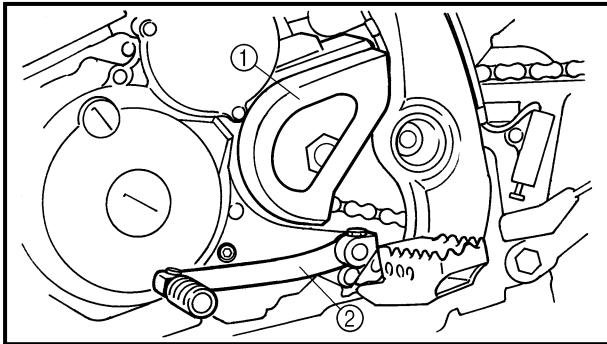

8. Install:

- Crankcase cover 2 ①
- Shift pedal ②



Bolt (crankcase cover 2):
10 Nm (1.0 m · kg, 7.2 ft · lb)
Bolt (shift pedal):
10 Nm (1.0 m · kg, 7.2 ft · lb)

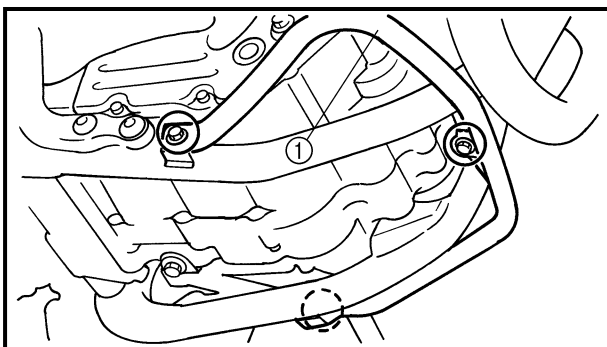

9. Install:

- Engine guard ①



Bolt (engine guard):
7 Nm (0.7 m · kg, 5.1 ft · lb)



10. Apply:
- Lithium soap base grease
(onto the O-ring on starter motor)
11. Install:
- Starter motor



Bolts (starter motor):
10 Nm (1.0 m • kg, 7.2 ft • lb)

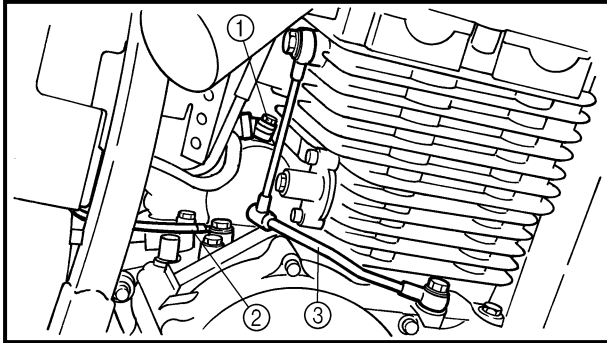

12. Connect:
- Starter motor lead ①
 - Ground lead ②
13. Install:
- Gas chamber
Refer to "ENGINE REMOVAL".
14. Install:
- Oil delivery pipe ③

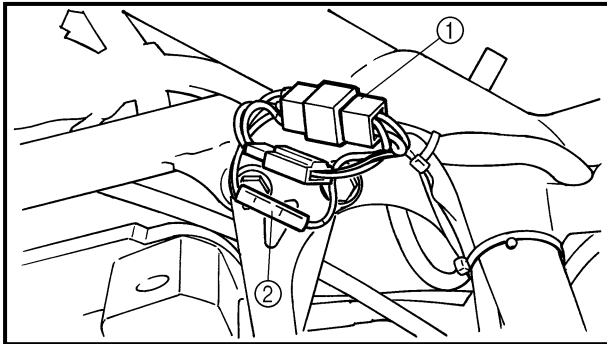

15. Connect:
- A.C. magneto lead ①
 - Neutral switch lead ②

16. Connect:
- Spark plug lead
17. Connect:
- Clutch cable
18. Adjust:
- Clutch cable free play
Refer to "CLUTCH ADJUSTMENT" in
CHAPTER 3.



Free play:
10 ~ 15 mm (0.39 ~ 0.59 in)
at clutch lever end

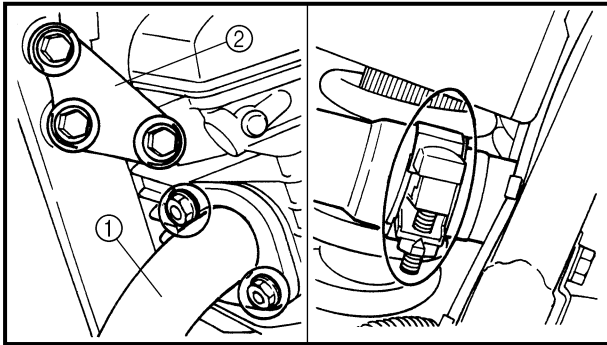

19. Install:

- Exhaust pipe ①
- Engine stay ②



Nuts (exhaust pipe):

20 Nm (2.0 m • kg, 14 ft • lb)

Bolt (clamp):

20 Nm (2.0 m • kg, 14 ft • lb)

Nuts (stay-frame):

30 Nm (3.0 m • kg, 22 ft • lb)

Nut (stay-engine):

64 Nm (6.4 m • kg, 46 ft • lb)

20. Connect:

- Battery negative lead
Refer to "BATTERY INSPECTION" in CHAPTER 3.

21. Connect:

- Carburetor
- Air vent hose
Refer to "CARBURETOR" in CHAPTER 5.

22. Install:

- Fuel tank
Refer to "SEAT, FUEL TANK AND COVERS" in CHAPTER 3.

23. Fill:

- 4-stroke engine oil
(in to the crankcase)
Refer to "ENGINE OIL LEVEL INSPECTION" and "ENGINE OIL REPLACEMENT" in CHAPTER 3.



Oil quantity:

Total amount:

1.45 L (1.28 Imp qt, 1.53 US qt)



Oil check bolt:

7 Nm (0.7 m • kg, 5.1 ft • lb)

Never start the engine when the oil has been drained.



CARBURETOR

CARBURETOR

- ① Throttle arm assembly
- ② Jet needle set
- ③ Throttle valve
- ④ Pump lever
- ⑤ Starter plunger assembly
- ⑥ Needle valve set
- ⑦ One-way valve
- ⑧ Diaphragm assembly (acceleration pump)
- ⑨ Check valve assembly
- ⑩ Float
- ⑪ Baffle plate
- ⑫ Needle jet
- ⑬ Main jet
- ⑭ Pilot jet
- ⑮ Pilot screw
- ⑯ Throttle stop screw

SPECIFICATIONS	
ID MARK	5GF1 00
MAIN JET (M.J.)	#137
PILOT JET (P.J.)	#52
JET NEEDLE (J.N.)	#5C9C-3/5
NEEDLE JET (N.J.)	2.595 (V95)
PILOT SCREW (P.S.)	1-1/2 turns out
FLOAT HEIGHT (F.H.)	26.5 ~ 27.5 mm (1.04 ~ 1.08 in)
FUEL LEVEL A (F.L.)	7.5 ~ 9.5 mm (0.30 ~ 0.37 in)
ENGINE IDLING SPEED	Below the float chamber mating surface 1,250 ~ 1,350 r/min

5

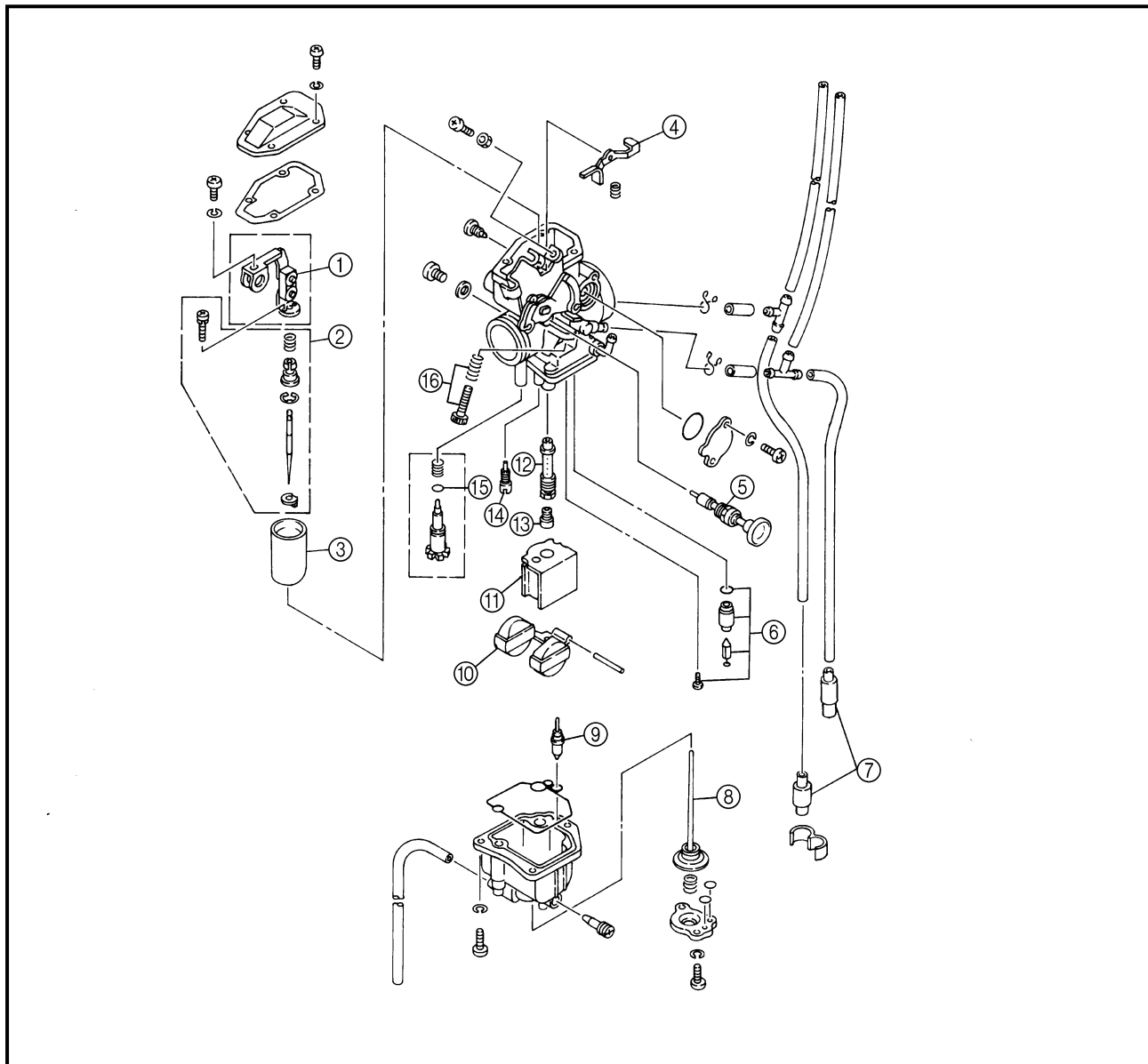



REMOVAL

1.Remove:

- Side covers
- Seat
- Fuel tank

Refer to "SEAT, FUEL TANK AND COVERS" in CHAPTER 3.

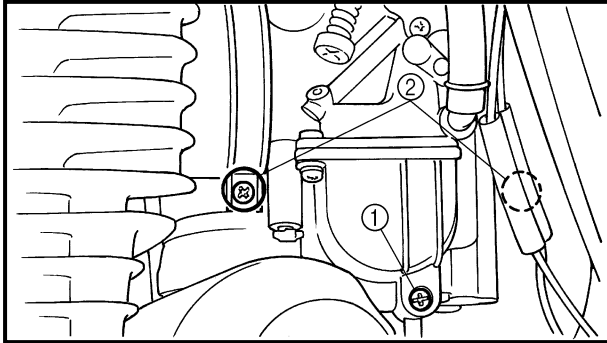

2.Drain:

- Fuel ① (float chamber)

Refer to "ENGINE REMOVAL" in CHAPTER 4.

3.Loosen:

- Clamps ② (carburetor joint)

4.Remove:

- Bolts (air filter case)

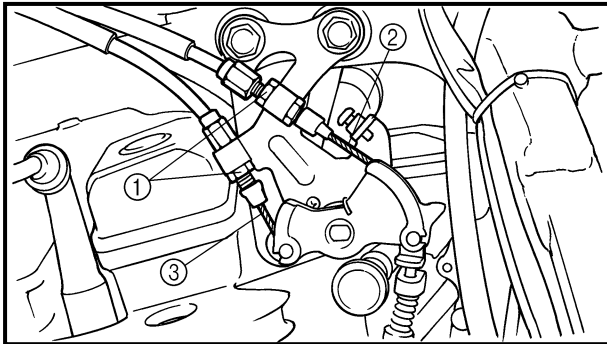

5.Loosen:

- Locknuts ①

6.Disconnect:

- Throttle cable 1 ②
- Throttle cable 2 ③
(from throttle lever and cable holder)
- Air vent hoses
- Fuel hose
- Over flow pipe

7.Remove:

- Carburetor

NOTE:

The air filter case must be pulled back so that the carburetor can be removed.



DISASSEMBLY

NOTE: _____

The following parts can be cleaned and inspected without disassembly.

- Starter plunger
- Throttle stop screw
- Pilot screw

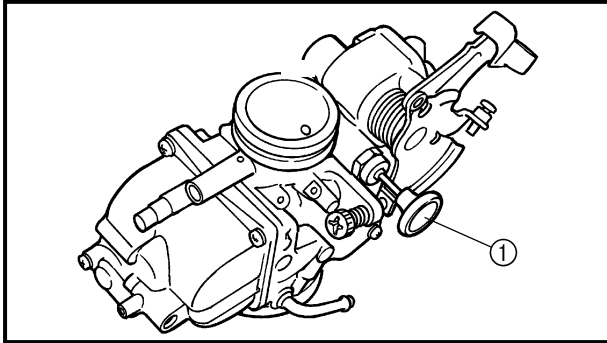

1.Disconnect:

- Starter plunger assembly ①

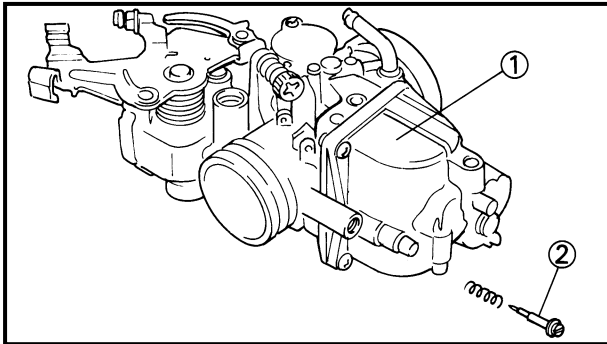

2.Remove:

- Float chamber ①
- Pilot screw ②

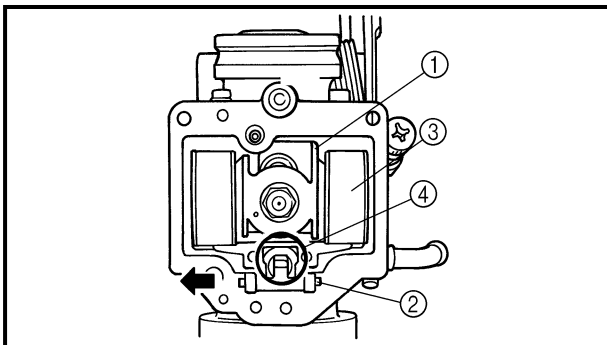

3.Remove:

- Baffle plate ①
- Float pin ②
- Float ③
- Needle valve assembly ④

NOTE: _____

Remove the float pin in the arrow direction.

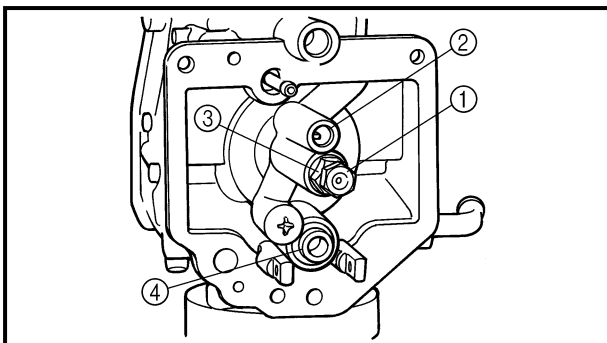

4.Remove:

- Main jet ①
- Pilot jet ②
- Main nozzle ③
- Valve seat ④

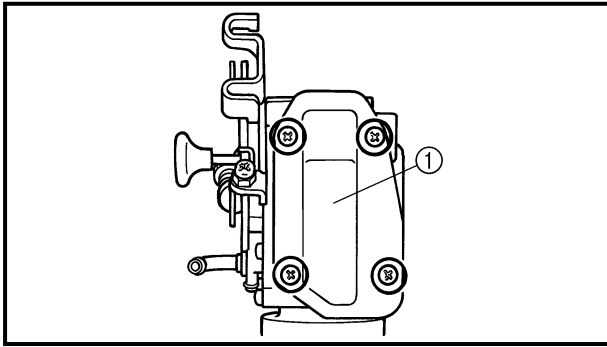

5.Remove:

- Cap (carburetor mixing chamber body) ①

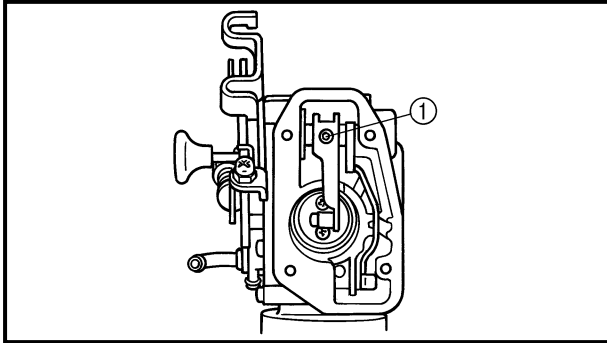

6.Remove:

- Screw (throttle arm) ①

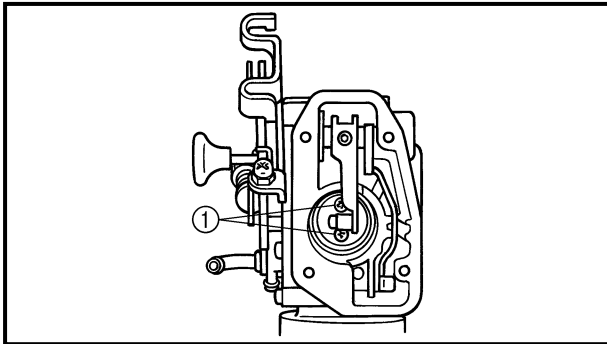

7.Remove:

- Screws (throttle valve) ①

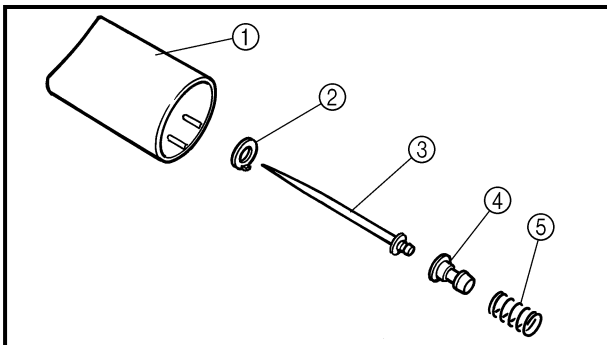

8.Remove:

- Throttle valve ①
- Ring ②
- Jet needle ③
- Needle holder ④
- Spring ⑤

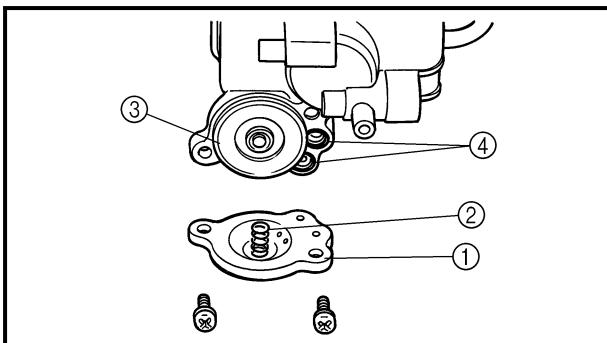

9.Remove:

- Cover assembly ①
- Spring ②
- Diaphragm ③
- O-ring ④

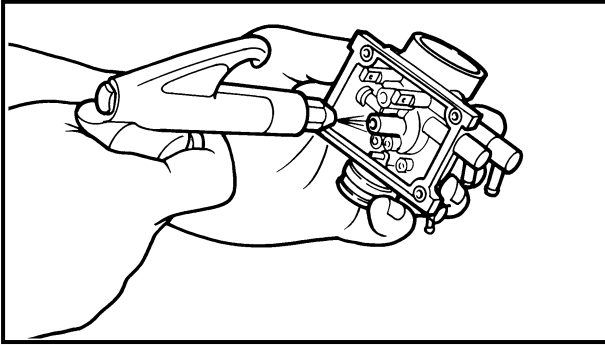

INSPECTION

1. Inspect:

- Carburetor mixing chamber body
 - Carburetor float chamber body
- Contamination → Blow out passages with compressed air.

NOTE:

Use a petroleum based solvent for cleaning. (Do not use any caustic carburetor cleaning solution.)

Blow out all passages and jets with compressed air.

CA

- **The starter jet is press-fit, so it is unremovable.**
- **Do not use a wire for cleaning.**

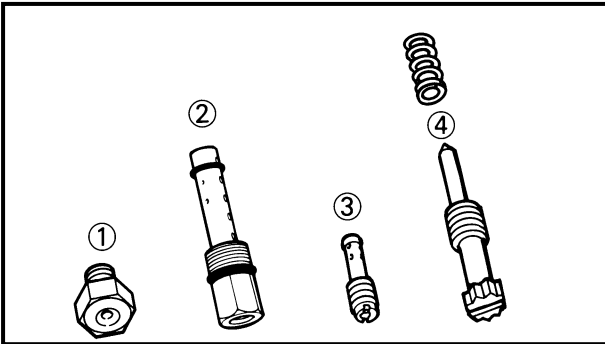

2. Inspect:

- Main jet ①
- Main nozzle ②
- Pilot jet ③
- Pilot screw ④

Wear/damage → Replace.

Clogs → Blow out the jets with compressed air.

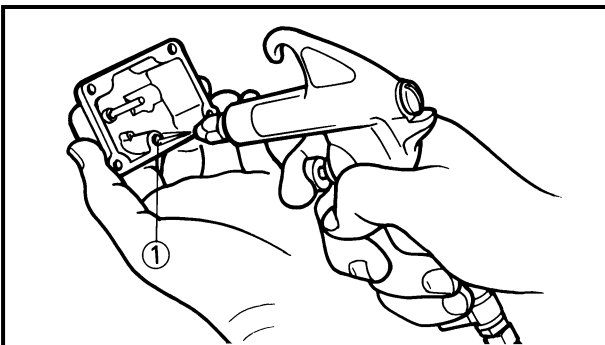

3. Inspect:

- Starter jet ①
- Contamination → Clean.

NOTE:

The starter jet is of a fixed type.

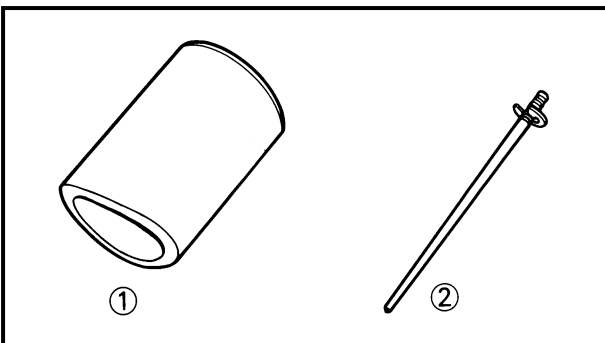

4. Inspect:

- Throttle valve ①
- Scratches/wear/damage → Replace diaphragm assembly.
- Jet needle ②
- Wear/bend/damage → Replace.

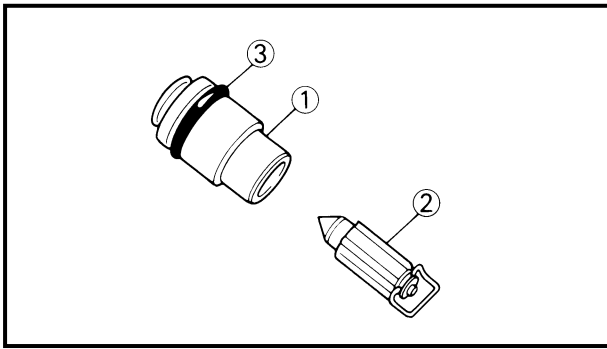

5. Inspect:

- Valve seat ①
- Needle valve ②
- O-ring ③

Damage/wear → Replace as a set.

NOTE:

Always replace the needle valve and valve seat as a set.

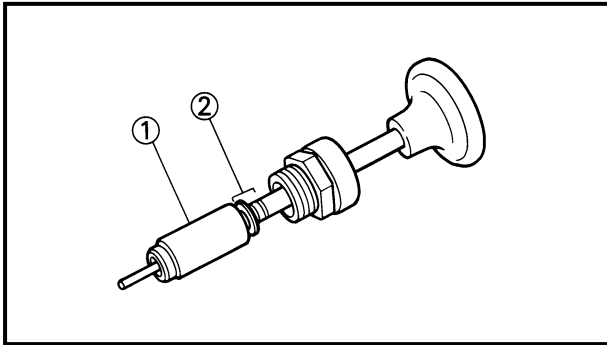

6. Inspect:

- Starter plunger ①
Bends/wear/damage → Replace.
- Spring ②
Damage → Replace.

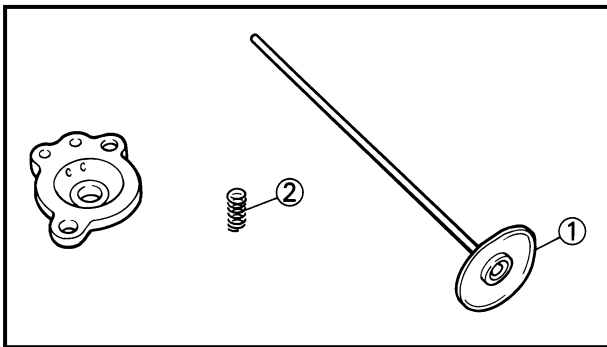

7. Inspect:

- Diaphragm ①
Tears/damage → Replace diaphragm assembly.
- Spring ②
Damage → Replace.

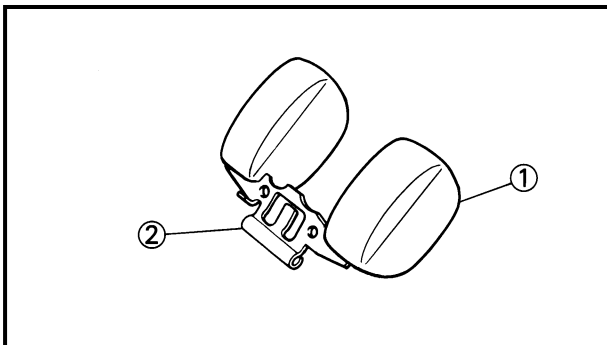

8. Inspect:

- Float ①
- Float arm ②
Damage → Replace.

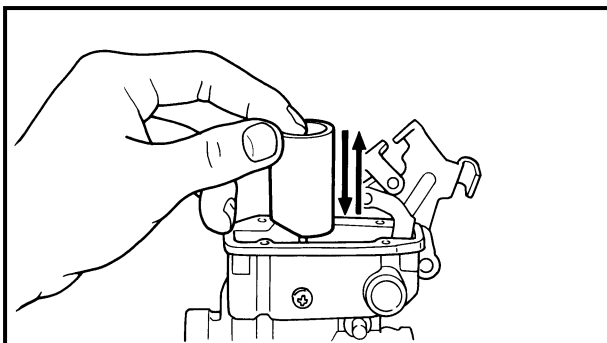

9. Check:

- Free movement
Stick → Replace.
Insert the throttle valve into the carburetor body, and check for free movement.



ASSEMBLY

Reverse the "DISASSEMBLY" procedures.
Note the following points.

Before reassembling, wash all the parts in clean petroleum based solvent.

Always use a new gasket.

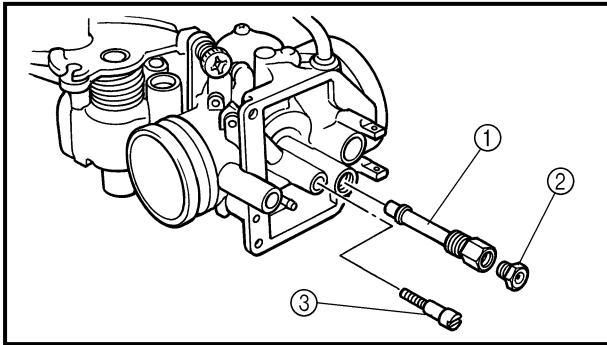

1.Install:

- Main nozzle ①
- Main jet ②
- Pilot jet ③

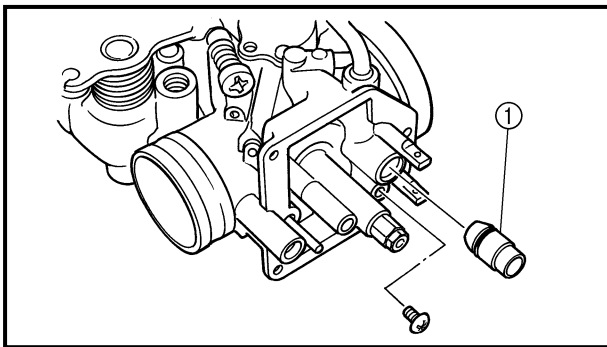

2.Install:

- Valve seat ①

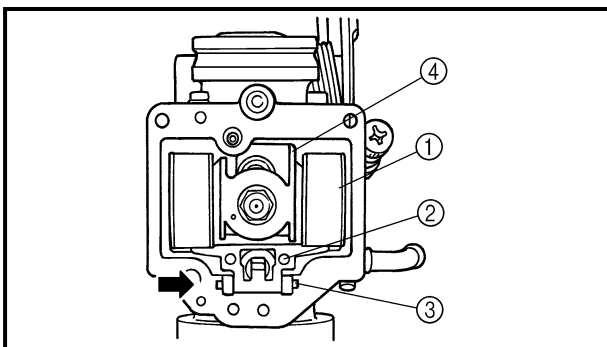

3.Install:

- Float ①
- Needle valve assembly ②
- Float pin ③
- Baffle plate ④

NOTE: Install the float pin in the arrow direction.

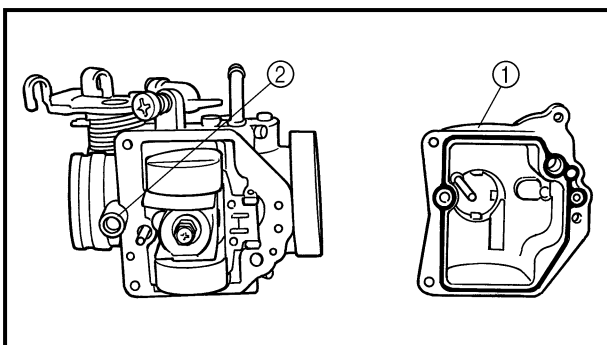

4.Install:

- Float chamber ①
- Pilot screw ②

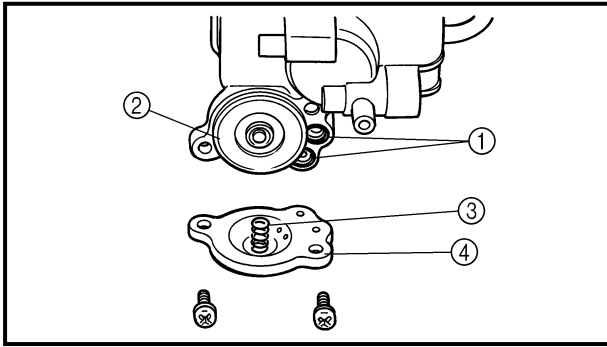

- 5.Install:
- O-ring ①
 - Diaphragm ②
 - Spring ③
 - Cover assembly ④

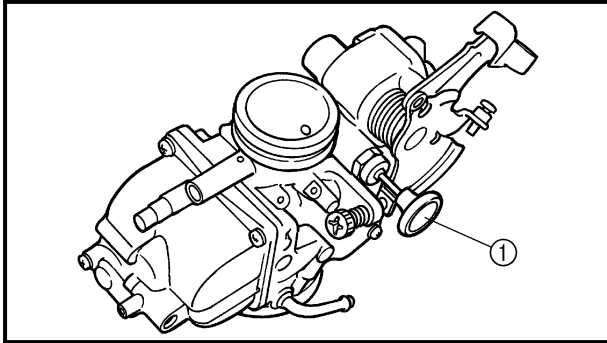

- 6.Install:
- Starter plunger assembly ①

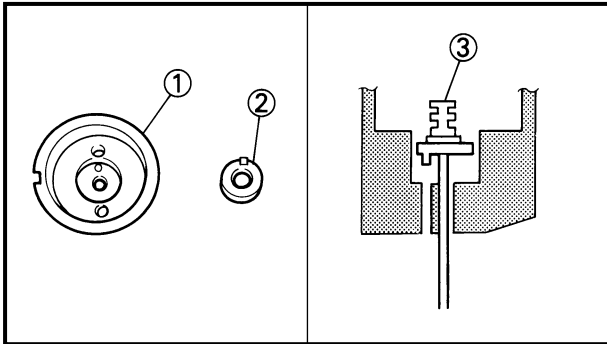

- 7.Install:
- Throttle valve ①
 - Ring ②
 - Jet needle ③

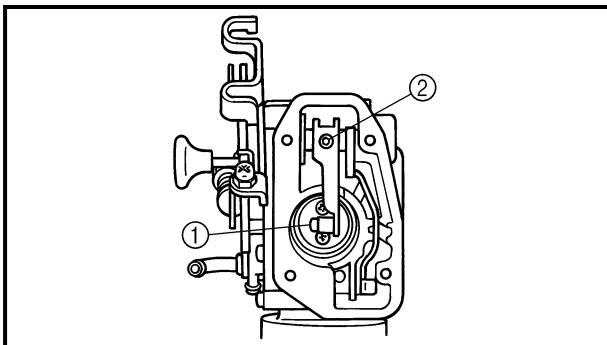

- 8.Install:
- Throttle valve ①
 - Throttle arm ②

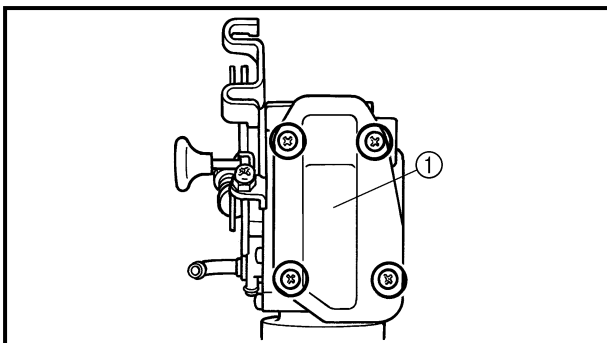

- 9.Install:
- Cap (mixing chamber assembly) ①

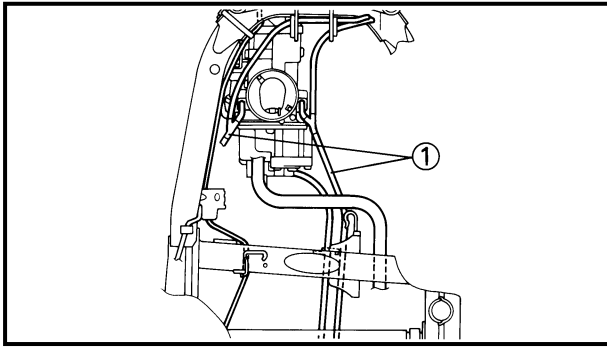

10. Install:
- Air vent hose ①
 - Fuel hose
 - Air vent hose

INSTALLATION

1. Install:
- Carburetor assembly
Refer to "ENGINE REMOVAL" in CHAPTER 4.

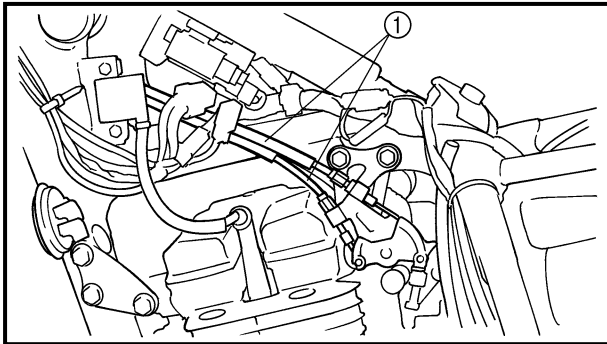

2. Install:
- Throttle cables ①
Refer to "CABLE ROUTING" in CHAPTER 2.

3. Adjust:
- Throttle cable free play
Refer to "THROTTLE CABLE FREE PLAY ADJUSTMENT" in CHAPTER 3.

	<p>Throttle cable free play: 3 ~ 5 mm (0.12 ~ 0.20 in)</p>
--	---

4. Adjust:
- Idle speed
Refer to "IDLING SPEED ADJUSTMENT" in CHAPTER 3.

	<p>Engine idle speed: 1,250 ~ 1,350 r/min</p>
--	--

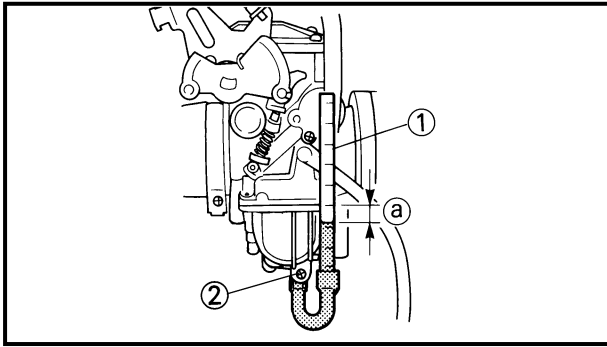

FUEL LEVEL ADJUSTMENT

1. Place the motorcycle on a level place.
2. Use a suitable stand under the frame and engine to ensure that the carburetor is positioned vertically.
3. Connect the fuel level gauge (1) to the float chamber drain pipe.



Fuel level gauge:
P/N. YM-01312-A

4. Turn the fuel cock to "ON" or "RES".
5. Loosen the drain screw (2).
6. Hold the gauge vertically next to the float chamber mating surface (front).
7. Measure:
 - Fuel level (a)
 Out of specification → Adjust.



Fuel level:
7.5 ~ 9.5 mm (0.30 ~ 0.37 in)
Below the float chamber mating surface (front)

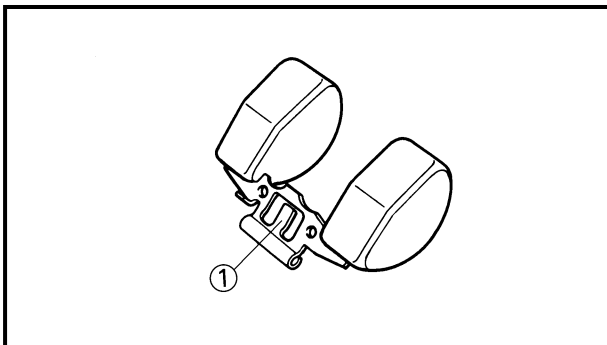

8. Adjust:
 - Fuel level

Adjustment steps:

- Remove the carburetor.
- Inspect the valve seat and needle valve.
- If either is worn, replace them both.
- If both are fine, adjust the float height by bending the float tang (1) on the float.
- Recheck the fuel level.

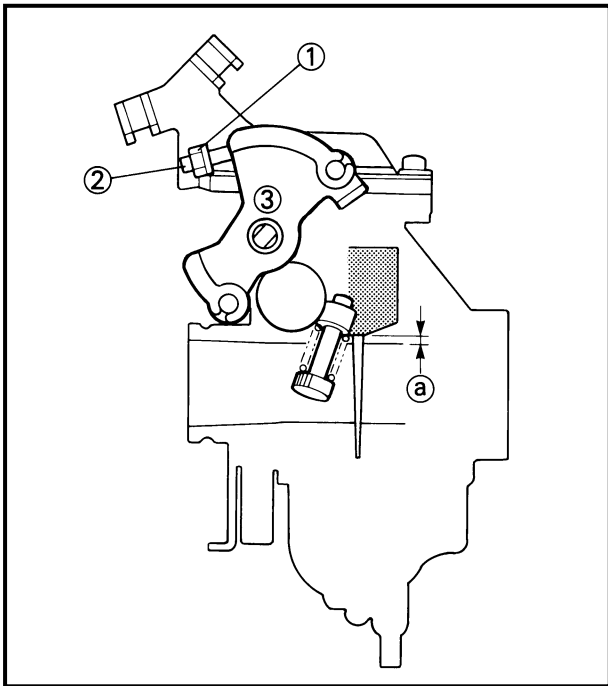

THROTTLE VALVE POSITION

1.Adjust:

- Throttle valve position

Adjustment steps:

- Loosen the locknut ①.
- Turn the throttle grip to the full-throttle position ③.
- Turn the adjuster ② in or out so that throttle valve bottom is positioned within the limits as specified.



Throttle valve position ①:
0 ~ 1 mm (0 ~ 0.04 in)

- Tighten the locknut.



CHASSIS

FRONT WHEEL

- ① Wheel axle
- ② Speedometer gear unit
- ③ Oil seal
- ④ Bearing
- ⑤ Spacer
- ⑥ Front wheel
- ⑦ Bearing
- ⑧ Oil seal
- ⑨ Collar

TIRE AIR PRESSURE (COLD):		
Maximum load-except motorcycle*	90 kg (198 lb)	
Cold tire pressure	Front	Rear
Off-road riding*	100 kPa (1 kg/cm ² , 14.5 psi)	100 kPa (1 kg/cm ² , 14.5 psi)

* Load is the total weight of rider and accessories.

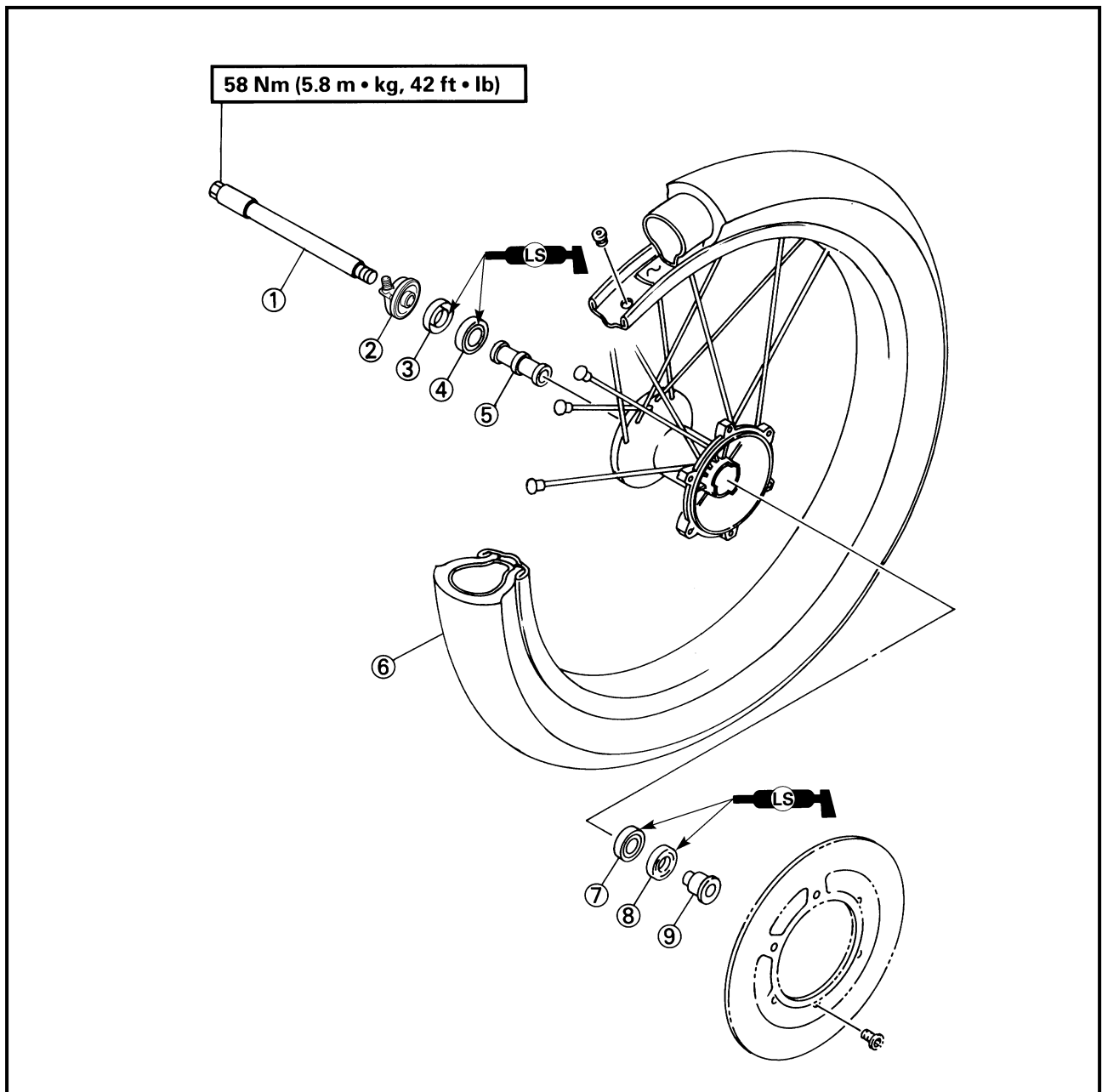

6



REMOVAL

⚠ WARNING

Securely support the motorcycle so there is no danger of it falling over.

1. Place the motorcycle on a level place.
2. Elevate the front wheel by placing a suitable stand under the frame and engine.

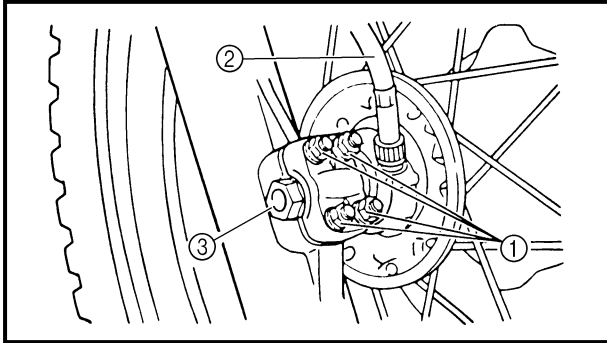

3. Loosen:
 - Nuts (axle holder) ①
4. Remove:
 - Speedometer cable ②
 - Wheel axle ③
 - Front wheel

NOTE:

Do not depress the brake lever when the wheel is off the motorcycle otherwise the brake pads will be forced shut.

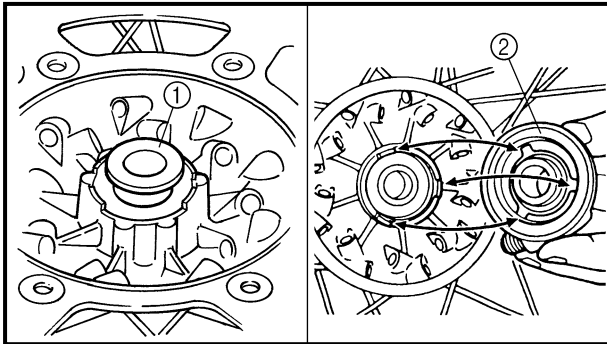

5. Remove:
 - Collar (left) ①
 - Speedometer gear unit ②

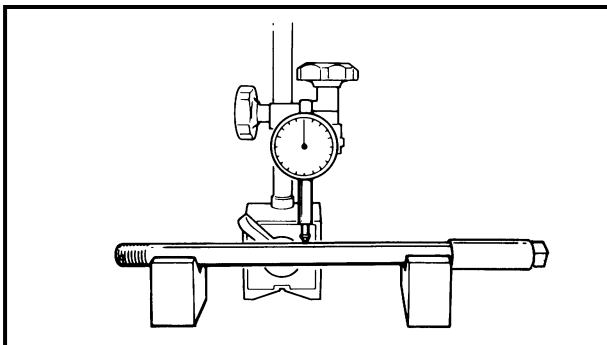

INSPECTION

1. Eliminate any corrosion from parts.
2. Inspect:
 - Wheel axle
 - Roll the axle on a flat surface.
 - Bends → Replace.

⚠ WARNING

Do not attempt to straighten a bent axle.

3. Inspect:
 - Tire
 - Wear/damage → Replace.
 - Refer to "TIRE INSPECTION" in CHAPTER 3.
 - Wheel
 - Bends/damage → Replace.
 - Refer to "WHEEL INSPECTION" in CHAPTER 3.

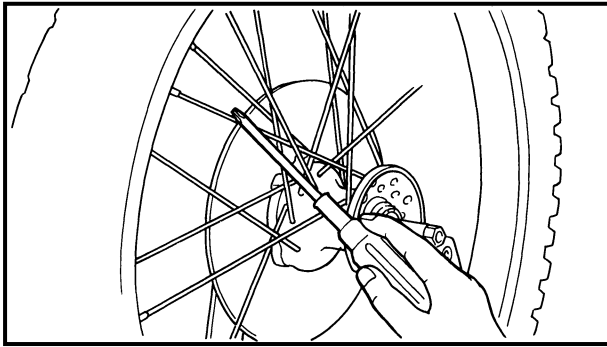

4. Check:

- Spoke(s)
Bend/damage → Replace.
Loose spoke(s) → Retighten.
Turn the wheel and tap the spokes with a screwdriver.

NOTE:

A tight spoke will emit a clear, ringing tone; a loose spoke will sound flat.

5. Tighten:

- Loose spokes



Nipple:

2 Nm (0.2 m • kg, 1.4 ft • lb)

NOTE:

Check the wheel runout after tightening the spokes.

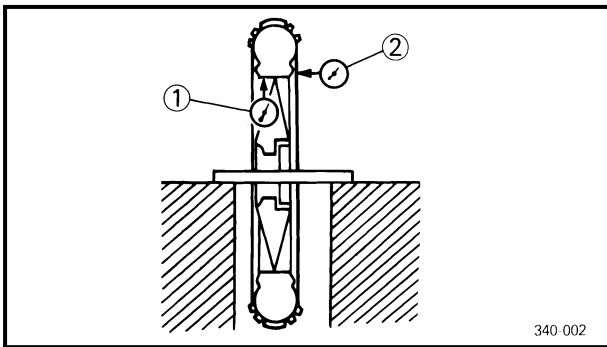

340-002

6. Measure:

- Wheel runout
Out of specification → Check the wheel and bearing play.



Rim runout limits:

Vertical ①: 2.0 mm (0.08 in)

Lateral ②: 2.0 mm (0.08 in)

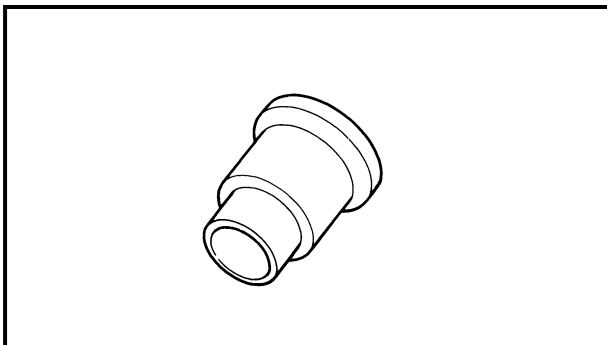

7. Inspect:

- Collar
Wear/damage → Replace.

⚠ WARNING

- After mounting a tire, ride conservatively to allow proper tire to rim seating. Failure to do so may cause an accident resulting in motorcycle damage and possible operator injury.
- After a tire repair or replacement, be sure to torque tighten the valve stem locknut ① to specification.

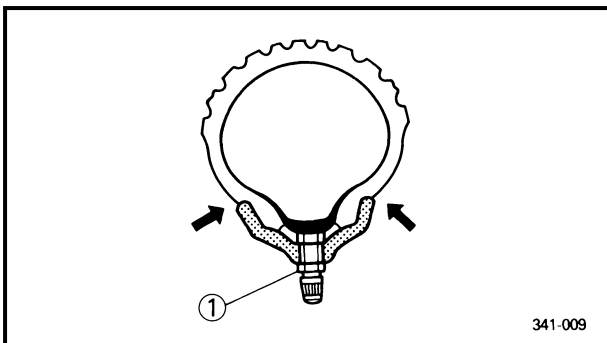

341-009



Valve stem locknut:

1.5 Nm (0.15 m • kg, 1.1 ft • lb)

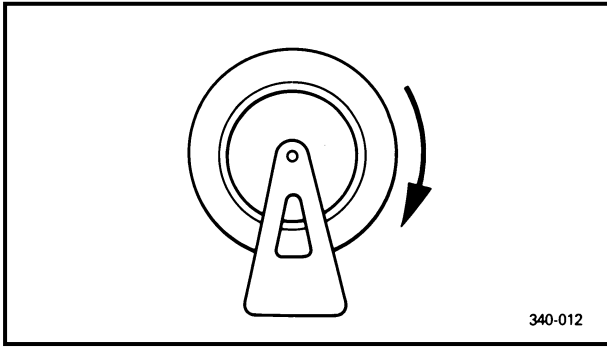

340-012

8. Check:

- Wheel bearings
Abnormal noise/turn roughly/free play → Replace.
- Oil seals
Wear/damage → Replace.

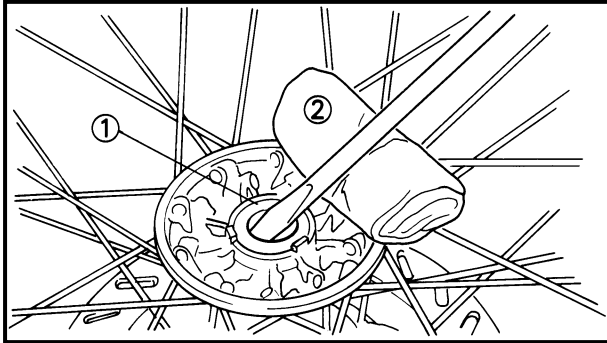

Oil seal and wheel bearing replacement steps:

- Clean the outside of the wheel hub.
- Remove the oil seal ① using a flat-head screwdriver.

NOTE: _____

Place a rag ② on the outer edge to prevent damage.

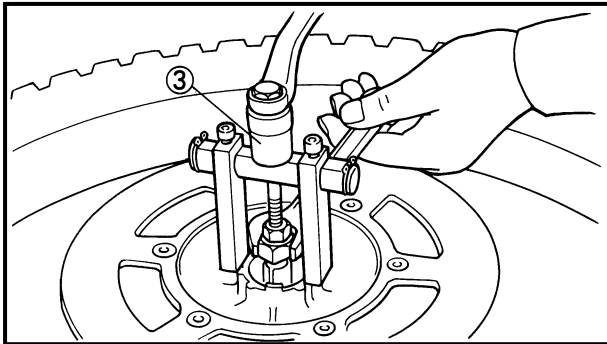

- Remove the bearings ③ using a general bearing puller.
- Install the new bearing and new oil seal by reversing the previous steps.

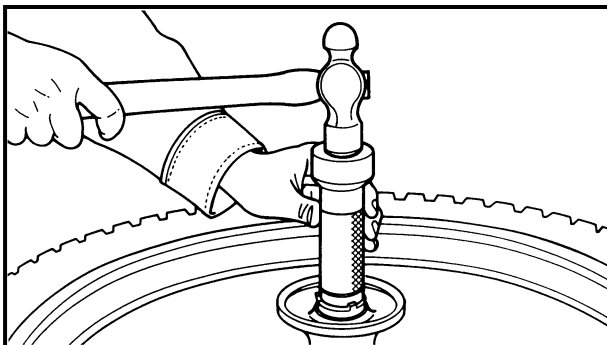

NOTE: _____

Use a socket that matches the outside diameter of the race of the bearing and oil seal.

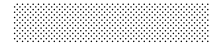

Do not strike the center race or balls of the bearing. Contact should be made only with the outer race.

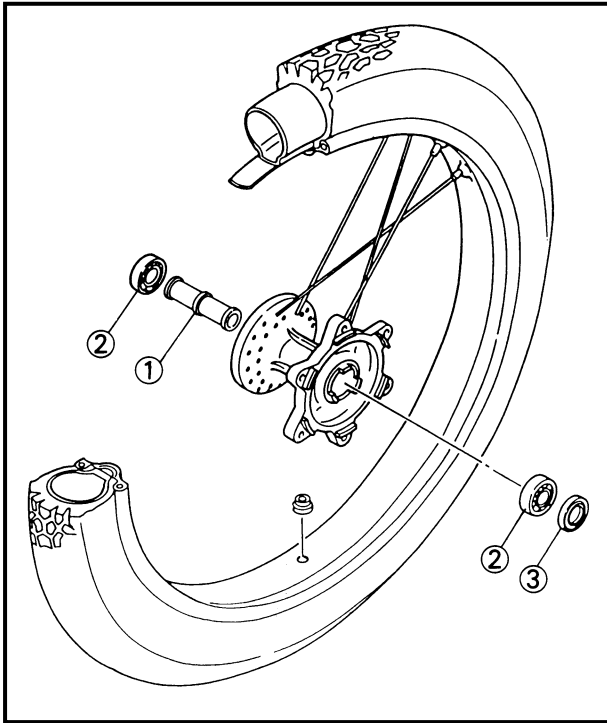

INSTALLATION

Reverse the "Removal" procedure.
Note the following points.

1. Lubricate:

- Wheel axle
- Spacer ①
- Bearings ②
- Oil seal (lips) ③

	Lithium soap base grease
--	---------------------------------

2. Install:

- Collar

NOTE: _____
Install the oil seal taking care not to damage or reverse the lips.

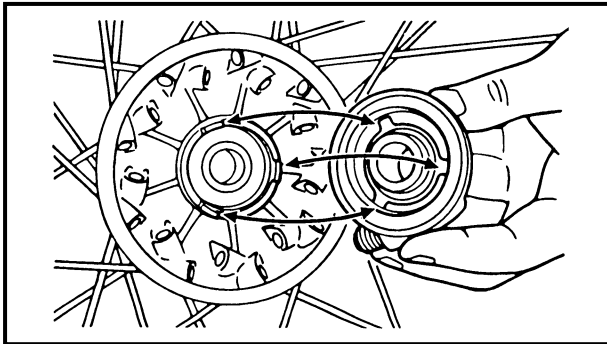

3. Install:

- Speedometer gear unit

NOTE: _____
Make sure that the wheel hub and the speedometer gear unit are installed with the projections meshed into the slots.

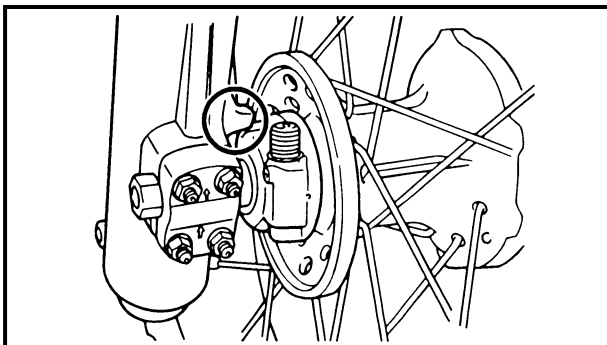

4. Install:

- Front wheel assembly

NOTE: _____
Make sure that the slot in the speedometer gear unit fits over the stopper on the front fork outer tube.

5. Tighten:

- Wheel axle

	Wheel axle: 58 Nm (5.8 m • kg, 42 ft • lb)
--	---

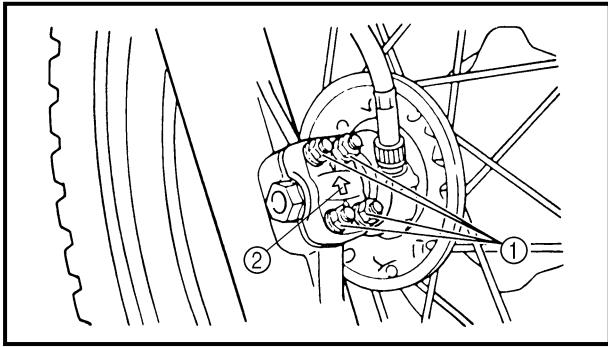

6.Tighten:

- Nuts (axle holder) ①

	<p>Nuts ①: 10 Nm (1.0 m • kg, 7.2 ft • lb)</p>
--	---

C _____
The axle holder should be installed with the arrow mark ② facing upward.

WHEEL STATIC BALANCE ADJUSTMENT

NOTE: _____

- After replacing the tire and/or rim, the wheel static balance should be adjusted.
- Adjust the wheel static balance with the brake disc installed.

1.Remove:

- Balancing weight

2.Set the wheel on a suitable stand.

3.Find:

- Heavy spot

Procedure:

- Spin the wheel and wait for it to rest.
- Put an "X₁" mark on the wheel bottom spot.
- Turn the wheel so that the "X₁" mark is 90° up.
- Left the wheel fall and wait for it to rest. Put an "X₂" mark on the wheel bottom spot.
- Repeat the above, b., c., and d. several times until these marks come to the same spot.
- This spot is the heavy spot "X".

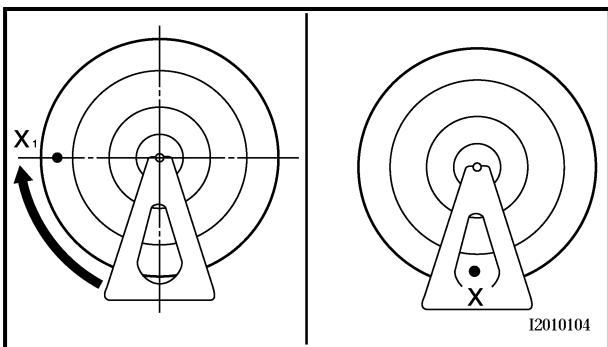
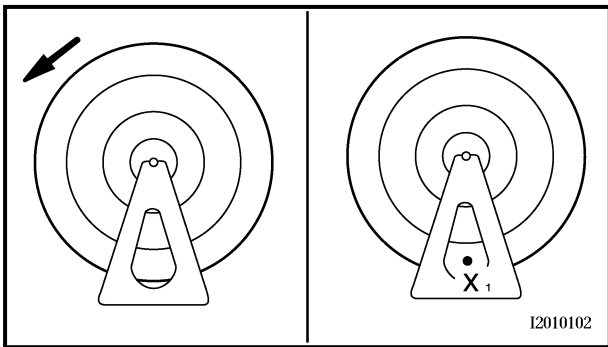

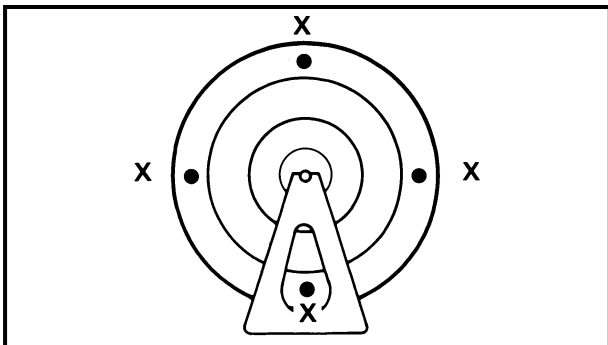
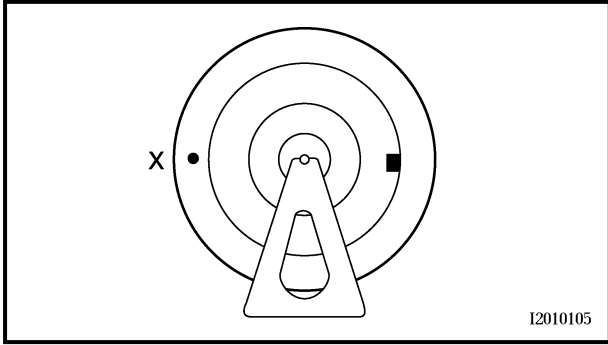
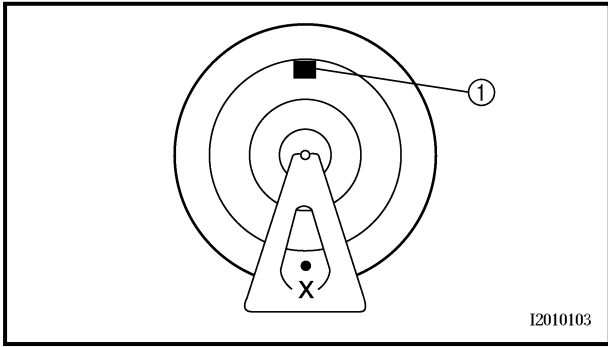

4.Adjust:

- Wheel static balance

Adjusting steps:

- Install a balancing weight ① on the rim exactly opposite to the heavy spot "X".

NOTE: _____
 Start with the smallest weight.

- Turn the wheel so that the heavy spot is 90° up.
- Check that the heavy spot is at rest there. If not, try another weight until the wheel is balanced.

NOTE: _____
 For the first and second measurements, mount a balancing weight or weights on the opposite side of the brake disc. For the third measurement and the following, mount them on the brake disc side.

CA _____
Do not install more than 4 pieces of balancing weight.

5.Check:

- Wheel static balance

Checking steps:

- Turn the wheel so that it comes to each point as shown.
- Check that the wheel is at rest at each point. If not, readjust the wheel static balance.



REAR WHEEL

- ① Rear wheel
- ② Cotter pin
- ③ Washer
- ④ Chain puller 2
- ⑤ Collar
- ⑥ Oil seal
- ⑦ Bearing
- ⑧ Rear hub
- ⑨ Bead stopper
- ⑩ Spacer
- ⑪ Bearing
- ⑫ Oil seal
- ⑬ Collar
- ⑭ Chain puller 1
- ⑮ Wheel axle

TIRE AIR PRESSURE (COLD):		
Maximum load-except motorcycle*	90 kg (198 lb)	
Cold tire pressure	Front	Rear
Off-road riding*	100 kPa (1 kg/cm ² , 14.5 psi)	100 kPa (1 kg/cm ² , 14.5 psi)

* Load is the total weight of rider and accessories.

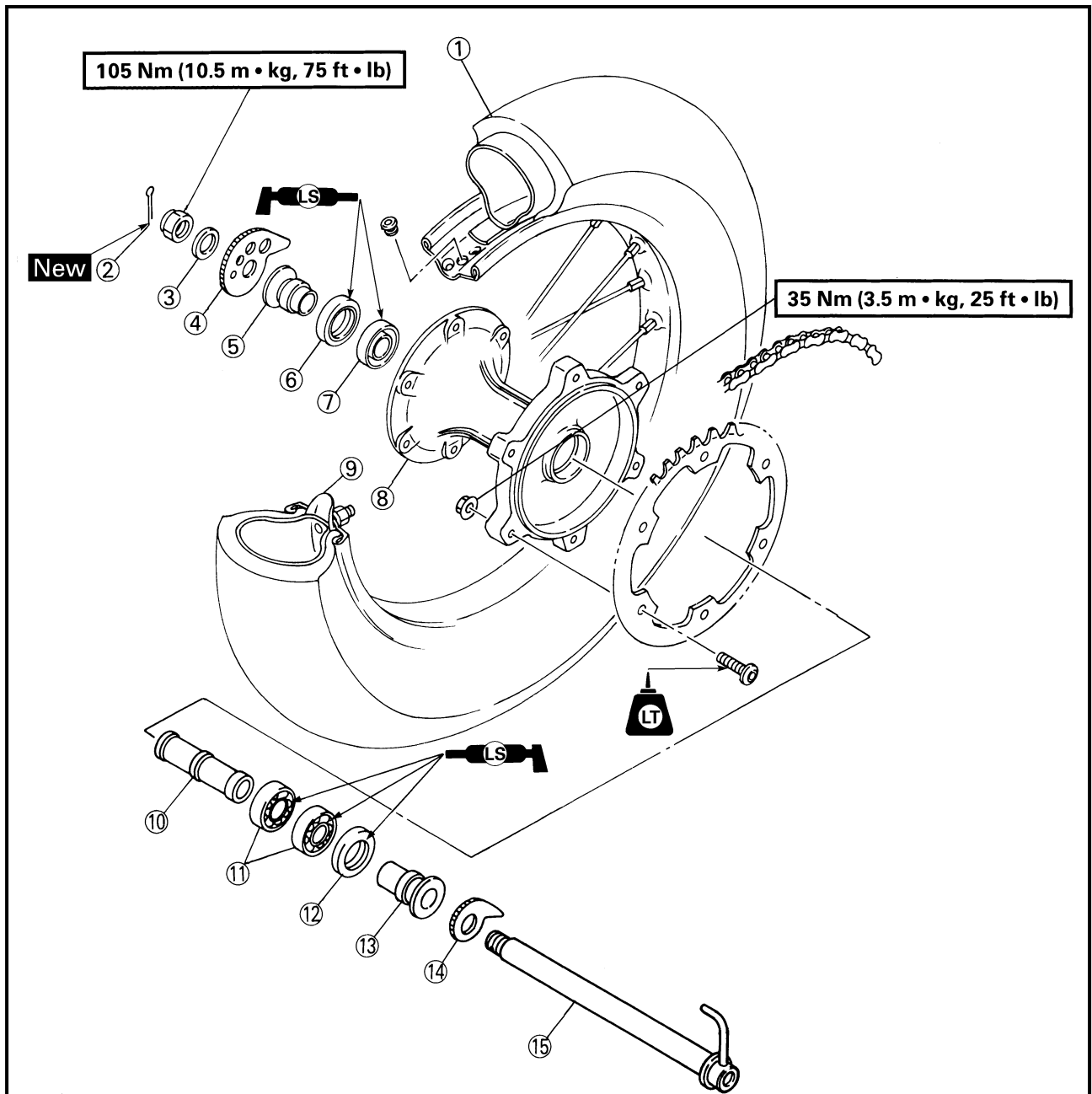



REMOVAL

1. Place the motorcycle on a level place.

⚠ WARNING

Securely support the motorcycle so there is no danger of it falling over.

2. Elevate the rear wheel by placing a suitable stand under the swingarm.

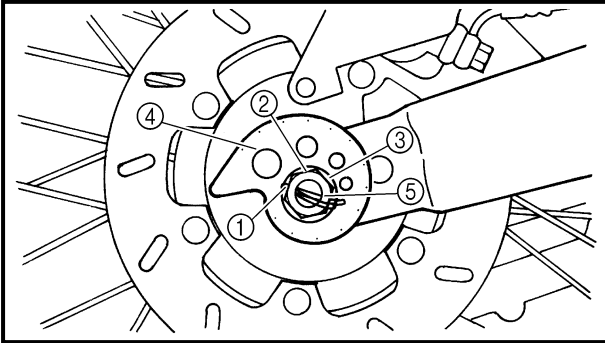

3. Remove:

- Cotter pin ①
- Axle nut ②
- Washer ③
- Chain puller 1 ④
- Wheel axle ⑤

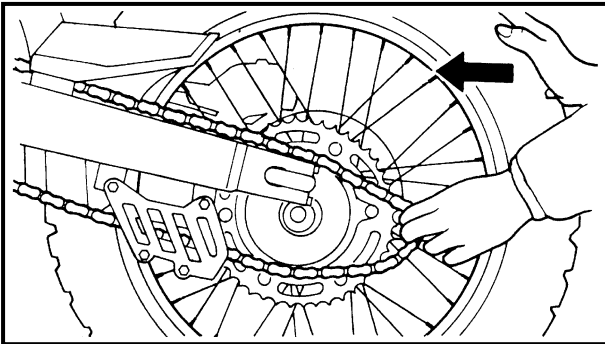

4. Remove:

- Rear wheel

NOTE:

Before removing the rear wheel, push the wheel forward and remove the drive chain.

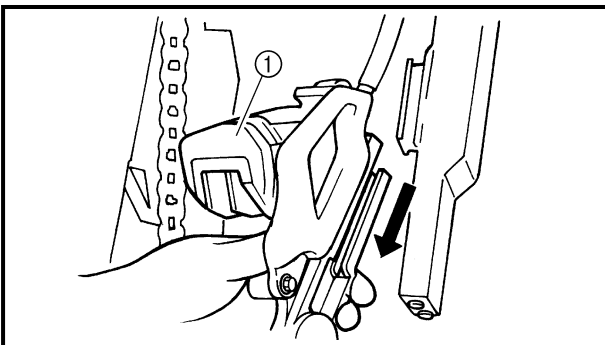

5. Remove:

- Rear brake caliper assembly ①

INSPECTION

1. Inspect:

- Tire
- Rear wheel axle
- Wheel

Refer to "FRONT WHEEL".



2.Measure:

- Wheel runout
Refer to "FRONT WHEEL".

3.Check:

- Spoke(s)
- Wheel bearings
- Oil seals
Refer to "FRONT WHEEL".

INSTALLATION

Reverse the "Removal" procedure.

Note the following points.

1.Lubricate:

- Rear wheel axle
- Bearings
- Oil seals

	<p>Recommended lubricant: Lithium soap base grease</p>
--	---

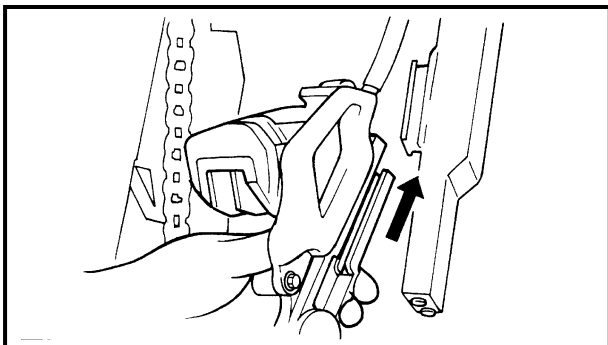

2.Install:

- Rear brake caliper assembly

3.Install:

- Rear wheel

4.Adjust:

- Drive chain slack

	<p>Drive chain slack: 35 ~ 50 mm (1.38 ~ 1.97 in)</p>
--	--

Refer to "DRIVE CHAIN SLACK ADJUSTMENT" in CHAPTER 3.

5.Tighten:

- Nut (rear wheel axle)

	<p>Nut (rear wheel axle): 105 Nm (10.5 m · kg, 75 ft · lb)</p>
--	---

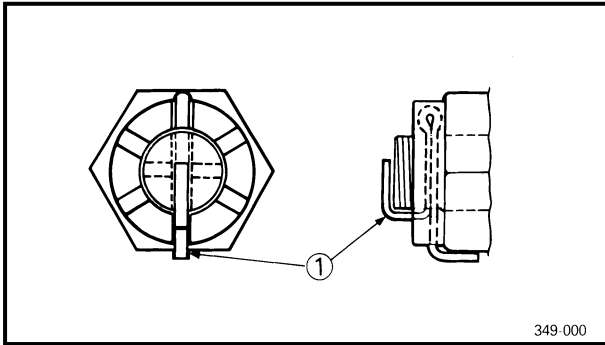

6.Install:

- Cotter pin ①

NOTE: _____

Bend the ends of the cotter pin.

⚠ WARNING _____

Always use a new cotter pin.

NB272004

WHEEL STATIC BALANCE ADJUSTMENT

NOTE: _____

- After replacing the tire and/or rim, the wheel static balance should be adjusted.
- Adjust the wheel static balance with the brake disc and the wheel hub installed.

1.Adjust:

- Wheel static balance

Refer to "FRONT WHEEL – WHEEL STATIC BALANCE ADJUSTMENT".



FRONT AND REAR BRAKE

- ① Master cylinder assembly
- ② Master cylinder cap
- ③ Diaphragm
- ④ Master cylinder kit
- ⑤ Brake hose
- ⑥ Brake caliper assembly
- ⑦ Caliper piston assembly
- ⑧ Caliper seal kit
- ⑨ Pad spring
- ⑩ Bleed screw
- ⑪ Brake pads
- ⑫ Pad pin
- ⑬ Brake disc

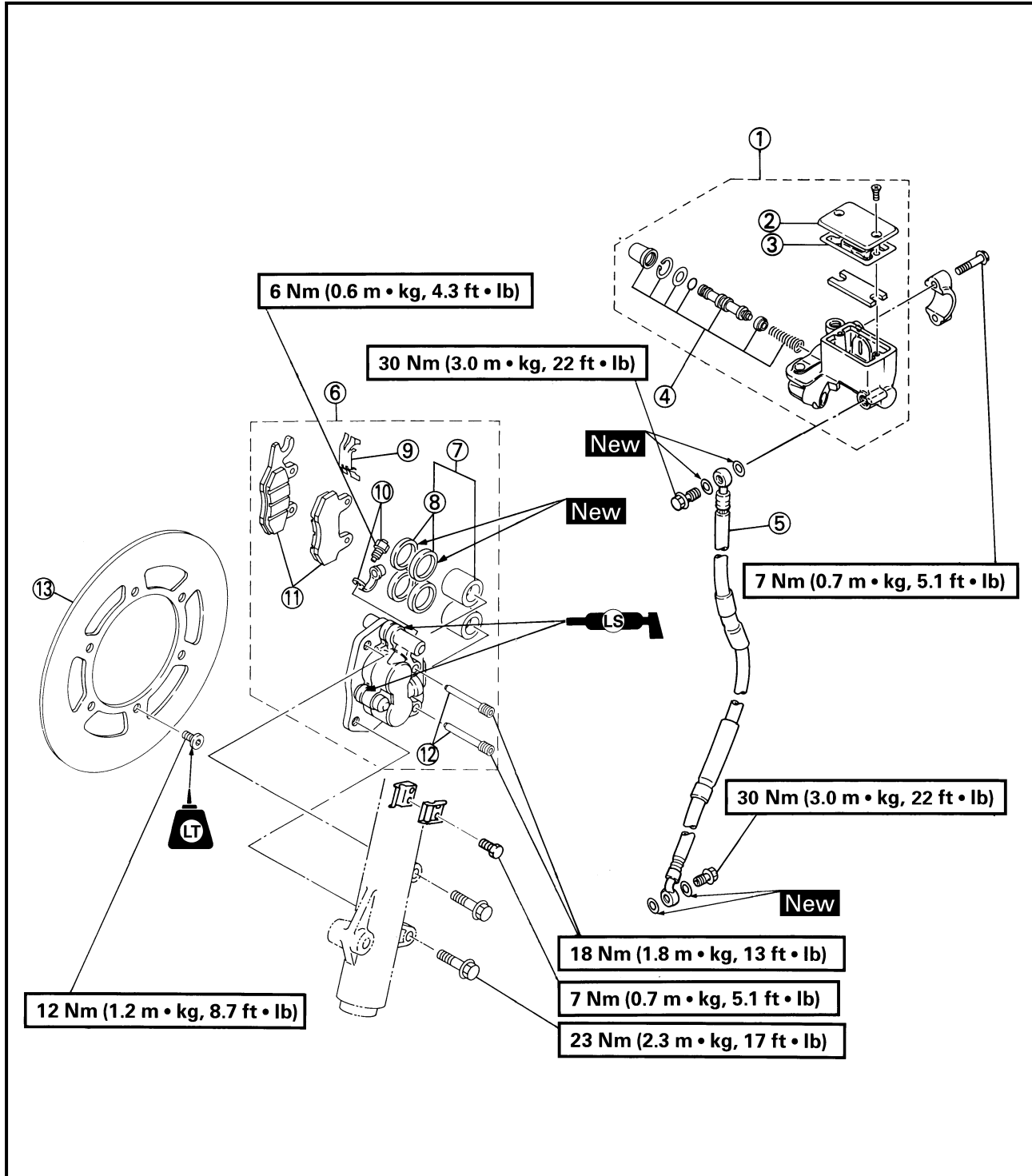

FRONT AND REAR BRAKE

CHAS



- ① Brake caliper assembly
- ② Caliper piston assembly
- ③ Caliper seal kit
- ④ Pad spring
- ⑤ Brake pads
- ⑥ Shim
- ⑦ Pad pin
- ⑧ Bleed screw
- ⑨ Brake disc

- ⑩ Protector
- ⑪ Brake hose holder
- ⑫ Brake hose
- ⑬ Master cylinder assembly
- ⑭ Master cylinder kit
- ⑮ Reservoir tank cap
- ⑯ Diaphragm bush
- ⑰ Diaphragm
- ⑱ Reservoir tank

- ⑲ Reservoir hose
- ⑳ Pin
- ㉑ Cotter pin

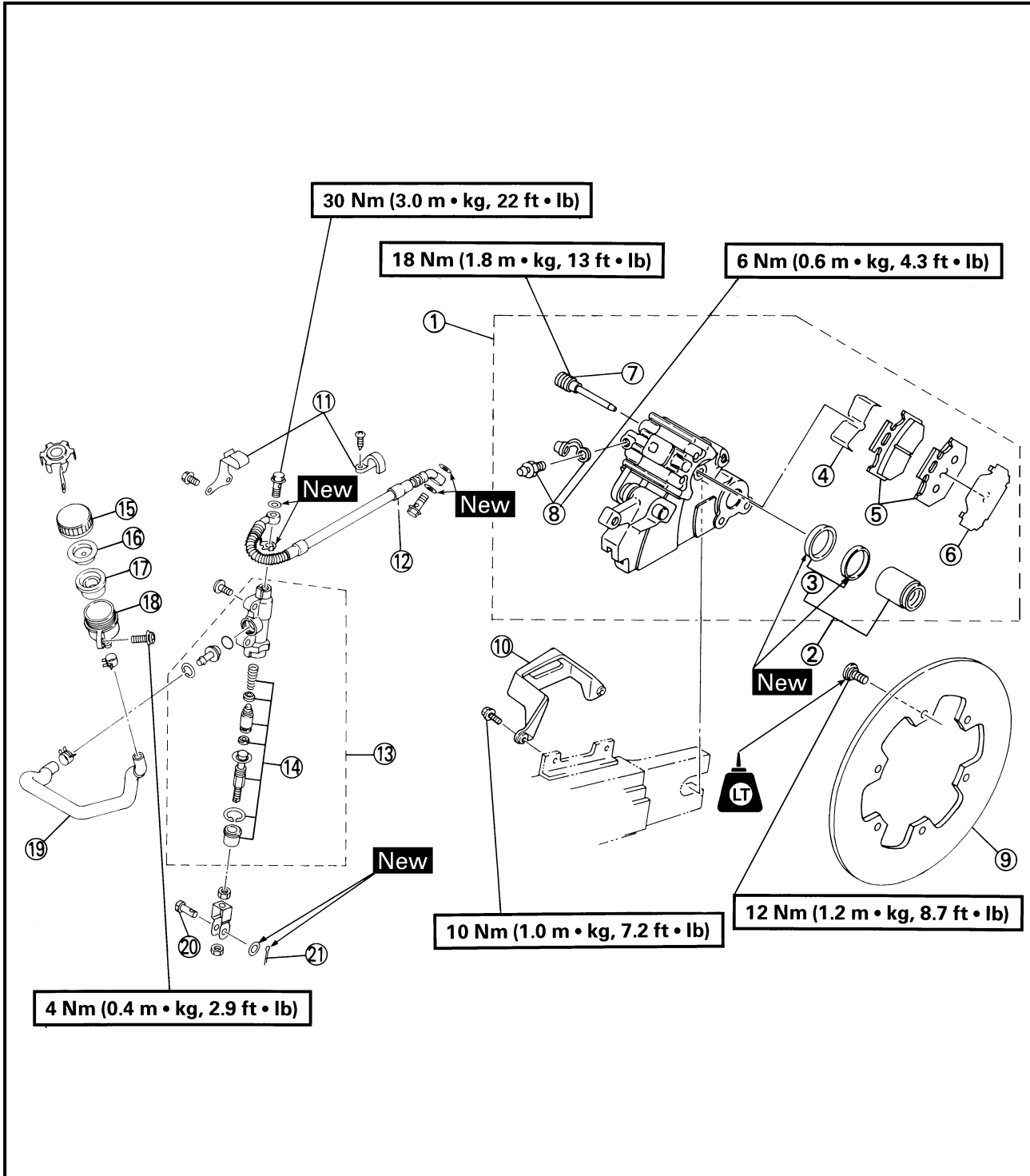



C

Disc brake components rarely require disassembly. DO NOT:

- Disassemble components unless absolutely necessary.
- Use solvents on internal brake component.
- Use contaminated brake fluid for cleaning.
- Allow brake fluid to come in contact with the eyes otherwise eye injury may occur.
- Allow brake fluid to contact painted surfaces or plastic parts otherwise damage may occur.
- Disconnect any hydraulic connection otherwise the entire system must be disassembled, drained, cleaned, and then properly filled and bled after reassembly.

⚠ WARNING

- Use only designated quality brake fluid: Otherwise, the rubber seals may deteriorate, causing leakage and poor brake performance.
- Refill with the same type of brake fluid: mixing fluids may result in a harmful chemical reaction and lead to poor performance.
- Be careful that water does not enter the master cylinder when refilling. Water will significantly lower the boiling point of the fluid and may result in vapor lock.

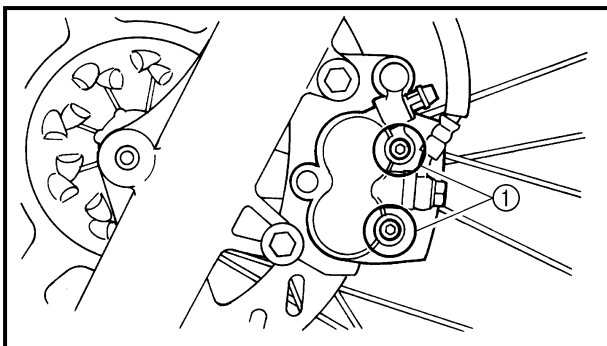

BRAKE PAD REPLACEMENT

NOTE:

It is not necessary to disassemble the brake caliper and brake hose to replace the brake pads.

Front brake

1. Loosen:
 - Pad pins ①

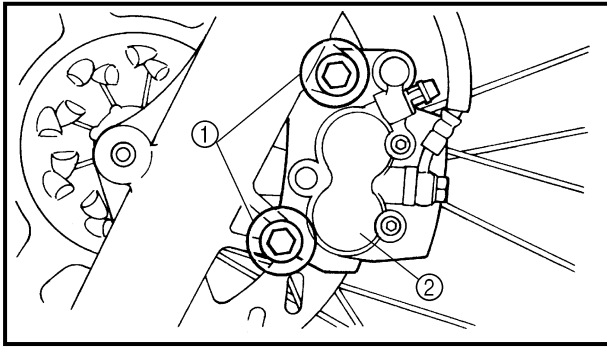

- 2.Remove:
- Bolts ①
 - Caliper body ②

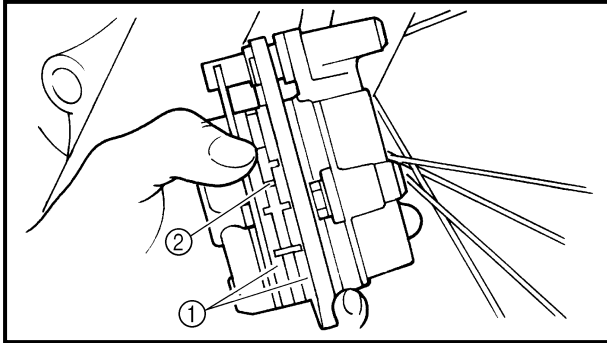

- 3.Remove:
- Pad pins ①
 - Brake pads ①
 - Pad spring ②

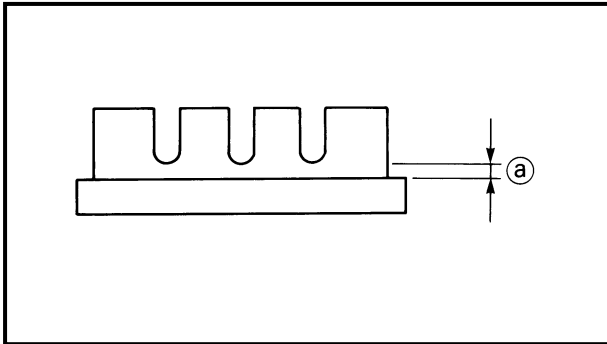

- NOTE:**
- Replace the pad spring if pad replacement is required.
 - Replace the pads as a set if either is found to be worn to the wear limit.



Wear limit ①:
1.0 mm (0.04 in)

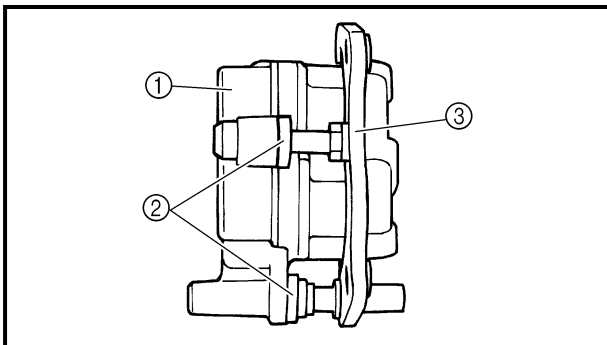

- 4.Inspect:
- Caliper body ①
Cracks/damage → Replace caliper assembly.
 - Rubber boot ②
Wear/cracks/damage → Replace.
 - Caliper bracket ③
- 5.Lubricate:
- Guide pins

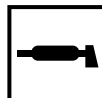

Recommended lubricant:
Lithium soap base grease

- NOTE:**
- Place the rubber boot ② securely in the groove of the slide collar when installing the guide pin.

- 6.Install:
- Caliper bracket

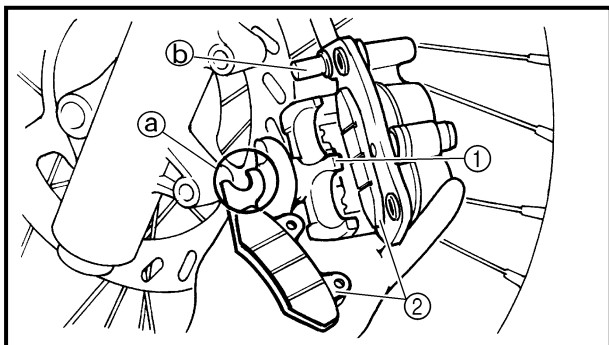

7. Install:

- Pad spring ①
- Brake pads ②
- Pad pins

	<p>Pad pins: 18 Nm (1.8 m • kg, 13 ft • lb)</p>
--	--

NOTE:

Install the brake pad (inner) with its (a) portion aligning with (b) of the caliper.

Installation steps:

- Connect a clear plastic tube ① tightly to the caliper bleed screw. Then, place the other end of this hose into an open container.
- Loosen the caliper bleed screw and push the piston into the caliper with your finger.
- Tighten the caliper bleed screw.

	<p>Caliper bleed screw: 6 Nm (0.6 m • kg, 4.3 ft • lb)</p>
--	---

8. Install:

- Caliper body

	<p>Bolts ① (caliper body): 23 Nm (2.3 m • kg, 17 ft • lb)</p>
--	--

⚠ WARNING

Proper hose routing is essential to insure safe motorcycle operation.
Refer to "CABLE ROUTING" in CHAPTER 2.

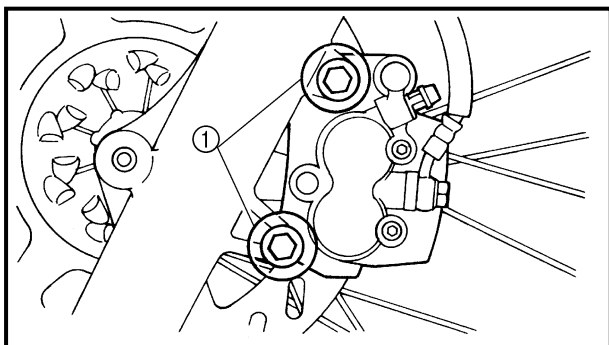
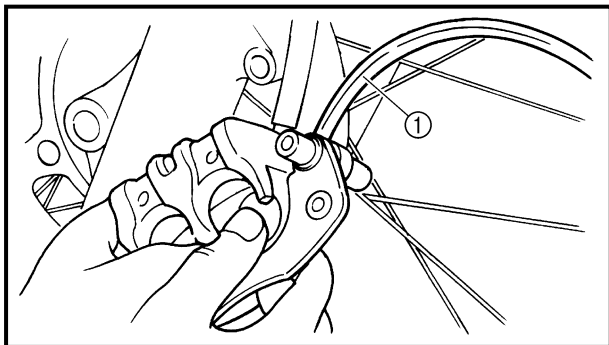

9. Inspect:

- Brake fluid level
Refer to "BRAKE FLUID INSPECTION" in CHAPTER 3.
- ① "LOWER" level line

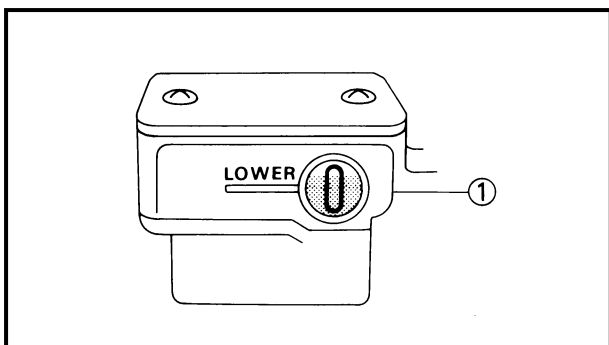



10. Check:

- Brake lever operation
A soft or spongy feeling → Bleed the brake system.
Refer to "AIR BLEEDING (HYDRAULIC BRAKE SYSTEM)" in CHAPTER 3.

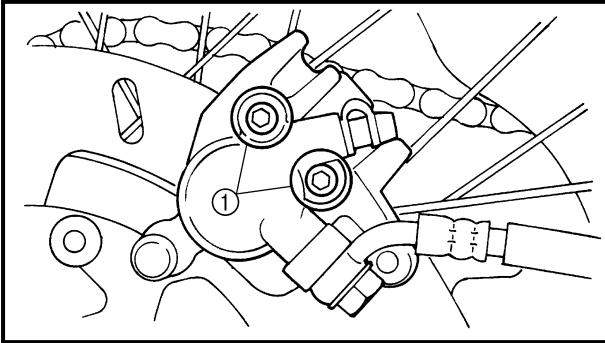

Rear brake

1. Remove:

- Caliper protector
- Pad pins ①

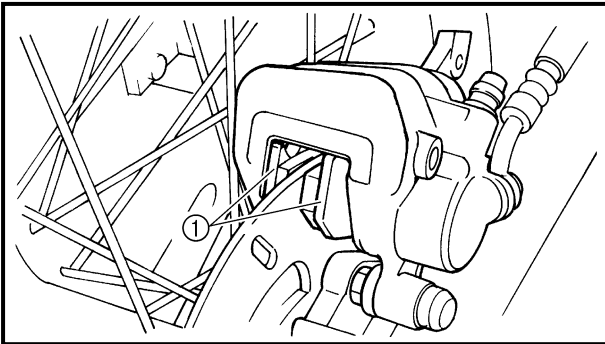

2. Remove:

- Brake pads ①
- Shim (piston side)

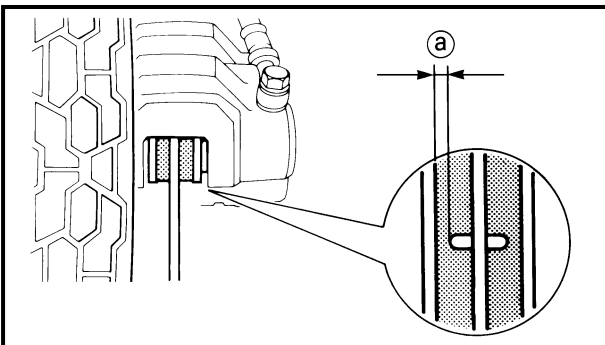

3. Measure:

- Pad thickness ②
Out of specification → Replace.

NOTE:

- Replace the pad spring if pad replacement is required.
- Replace the pads as a set if either is found to be worn to the wear limit.

	<p>Wear limit: 1.0 mm (0.04 in)</p>
--	--

4. Install:

- Brake pads (with pad shim)
- Pad pins

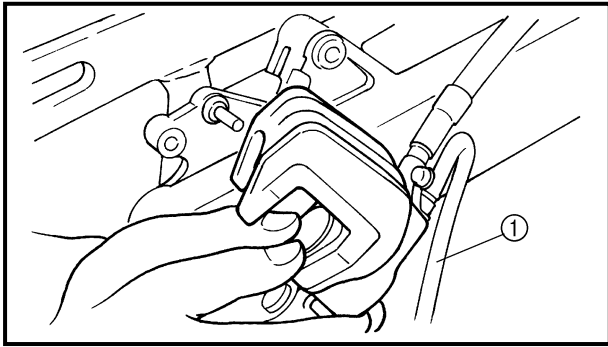

Installation steps:

- Connect a suitable hose ① tightly to the caliper bleed screw. Then, place the other end of this hose into an open container.
- Loosen the caliper bleed screw and push the pistons into the caliper with your finger.
- Tighten the caliper bleed screw.



Caliper bleed screw:
6 Nm (0.6 m • kg, 4.3 ft • lb)

- Install the pad spring (new).
- Install the pad shims (new) to the brake pads (new).
- Install the brake pads and pad pins.
- Tighten the pad pins.



Pad pins (brake pads):
18 Nm (1.8 m • kg, 13 ft • lb)

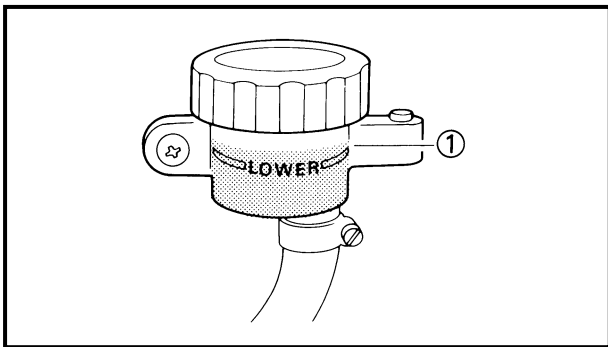

5. Inspect:

- Brake fluid level
Refer to "BRAKE FLUID LEVEL INSPECTION" in CHAPTER 3.
- ① "LOWER" level line

6. Check:

- Brake pedal operation
A soft or spongy feeling → Bleed the brake system.
Refer to "AIR BLEEDING (HYDRAULIC BRAKE SYSTEM)" in CHAPTER 3.

CALIPER DISASSEMBLY

NOTE:

Before disassembling the front brake caliper or rear brake caliper, drain the brake hoses, master cylinders, brake calipers and reservoir tanks of their brake fluid.

⚠ WARNING

Securely support the motorcycle so there is no danger of it falling over.

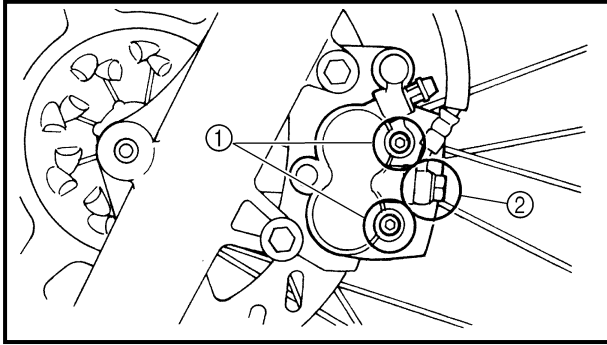

Front brake

1. Loosen:

- Pad pins ①
- Union bolt ②

2. Remove:

- Caliper body
Refer to "BRAKE PAD REPLACEMENT".

3. Remove:

- Pad pins
- Union bolt
- Copper washers

NOTE:

Place a container under the caliper to collect any remaining brake fluid.

4. Remove:

- Brake pads
- Pad spring

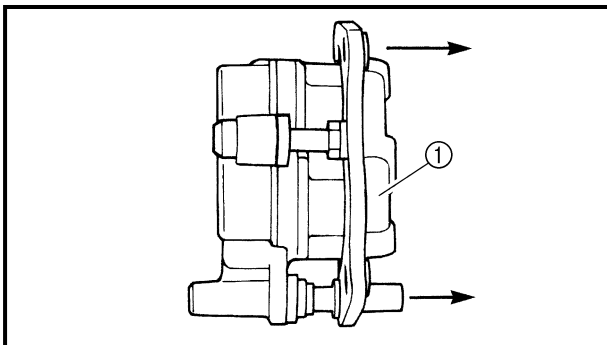

5. Remove:

- Support bracket ①

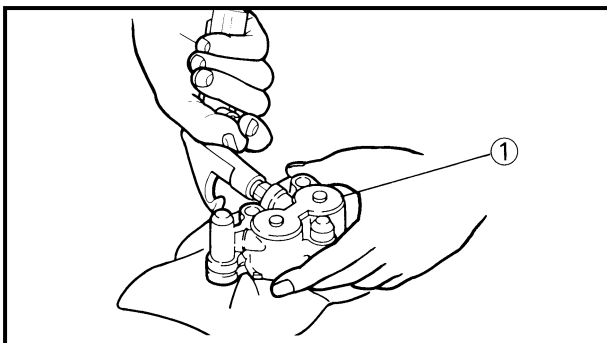

6. Remove:

- Piston ①

Removal steps:

- Blow compressed air into the tube joint opening to force out the piston from the caliper body.



⚠ WARNING

- Never try to pry out the piston.
- Cover the piston with a rag. Use care so that the piston does not cause injury as it is expelled from the cylinder.

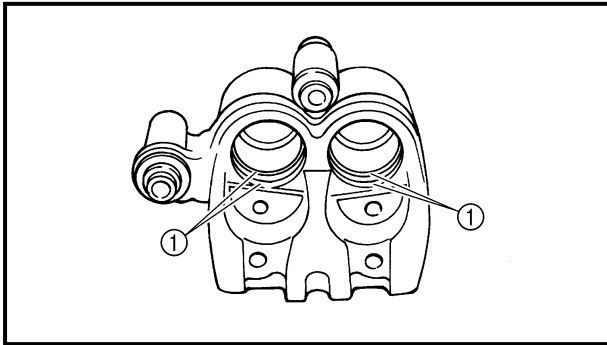

7.Remove:

- Piston seals ①

Remove the piston seal by pushing it in with a finger. Do not use a screwdriver.

Rear brake

NOTE:

Before disassembling the rear brake caliper, drain the brake system of its brake fluid.

⚠ WARNING

Securely support the motorcycle so there is no danger of it falling over.

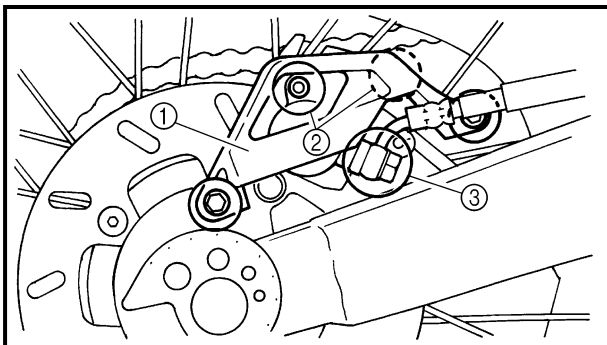

1.Remove:

- Cover ①
- 2.Loosen:
- Pad pins ②
 - Union bolt ③

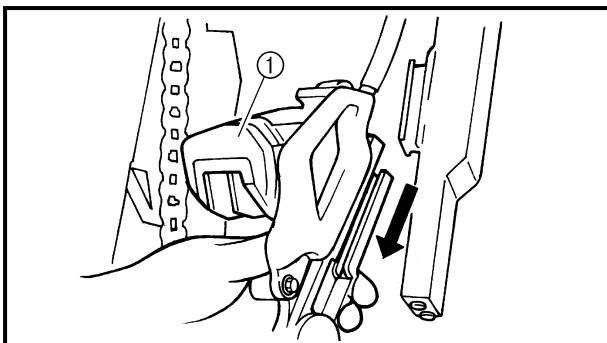

3.Remove:

- Rear wheel
 - Caliper assembly ①
- Refer to "REAR WHEEL".

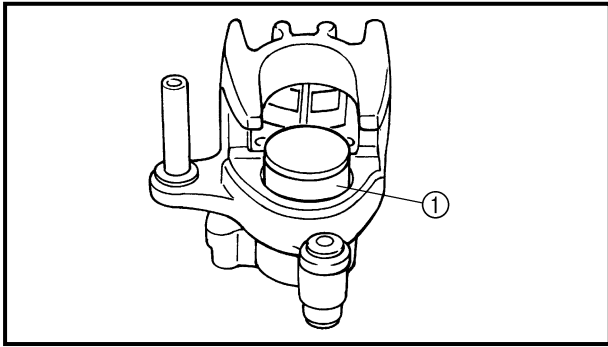

- 4.Remove:
- Union bolt
 - Pad pins
 - Brake pads (with pad shim)
 - Pad spring
- Refer to "BRAKE PAD REPLACEMENT".

- 5.Remove:
- Piston ①

Removal steps:

- Blow compressed air into the hose joint opening to force out the caliper pistons from the caliper body.

⚠ WARNING

- Never try to pry out the piston.
- Cover the piston with a rag. Use care so that the piston does not cause injury as it is expelled from the cylinder.

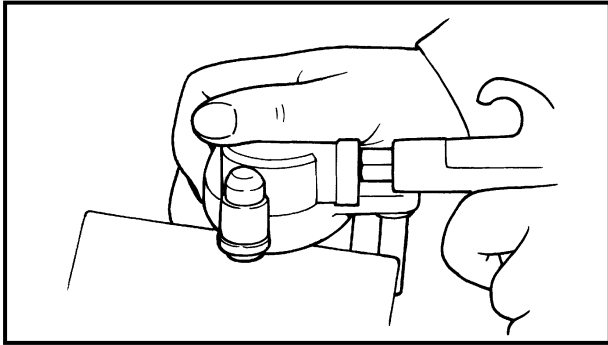

- 6.Remove:
- Piston seals ①

Remove the piston seal by pushing it in with a finger. Do not use a screwdriver.

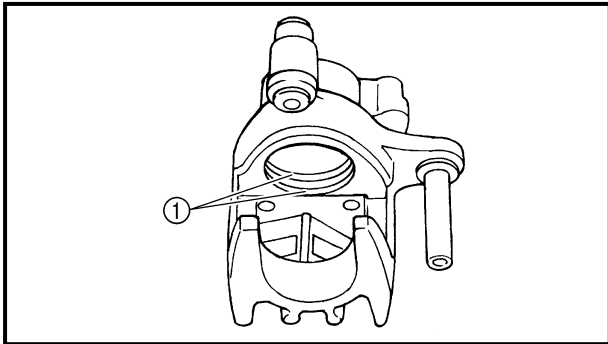

MASTER CYLINDER DISASSEMBLY

NOTE:

Before disassembling the front or rear brake master cylinders, drain the brake hoses, master cylinders, brake calipers and reservoir tanks of their brake fluid.

⚠ WARNING

Securely support the motorcycle so there is no danger of it falling over.



Front brake

1.Remove:

- Brush guard
- Brake lever
- Return spring (brake lever)
- Brake switch

NOTE: _____

Remove the brake switch by pushing up the stopper with a thin screwdriver.

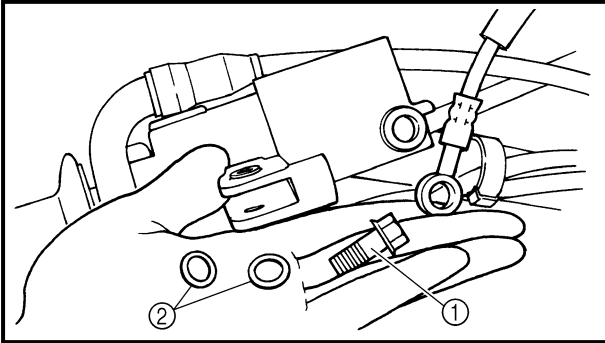

2.Remove:

- Union bolt ①
- Copper washers ②

NOTE: _____

Place a container under the master cylinder to collect any remaining brake fluid.

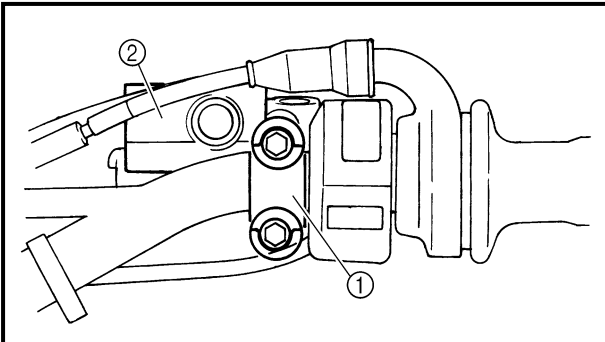

3.Remove:

- Master cylinder bracket ①
- Master cylinder ②

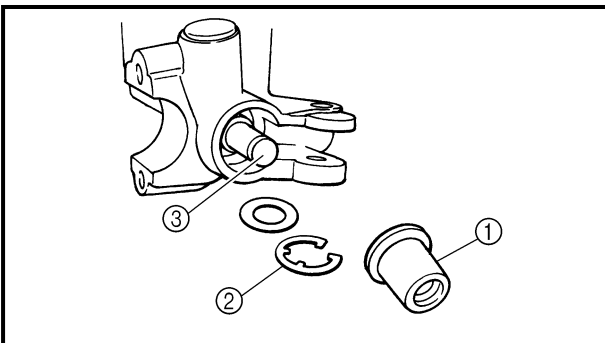

4.Remove:

- Master cylinder cap
- Diaphragm
- Rubber boot ①
- Circlip ②
- Master cylinder kit ③

NOTE: _____

Remove the circlip using circlip pliers.
Place a container under the master cylinder to collect any remaining brake fluid.

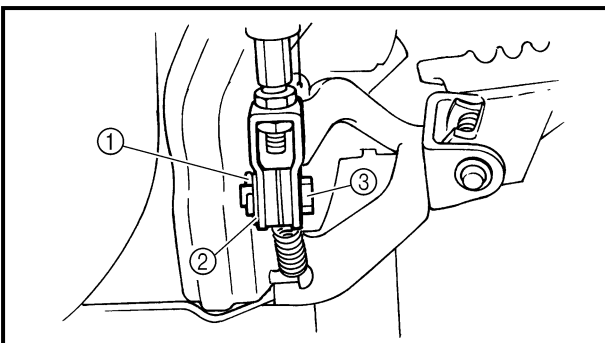

Rear brake

1.Remove:

- Cotter pin ①
- Washer ②
- Pin ③

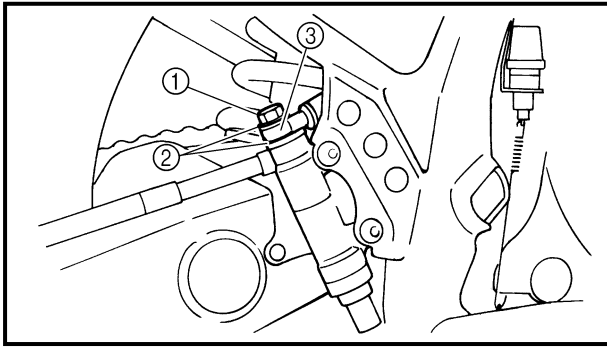

- 2.Remove:
- Union bolt ①
 - Copper washers ②
- 3.Disconnect:
- Brake hoses ③

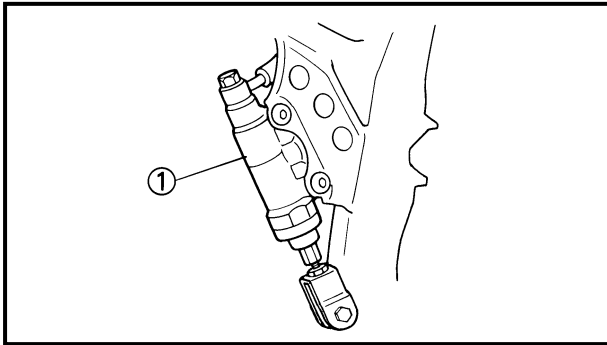

- 4.Remove:
- Master cylinder ①

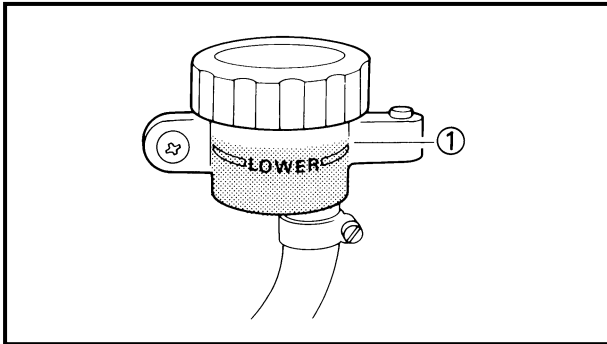

- 5.Remove:
- Reservoir tank ①

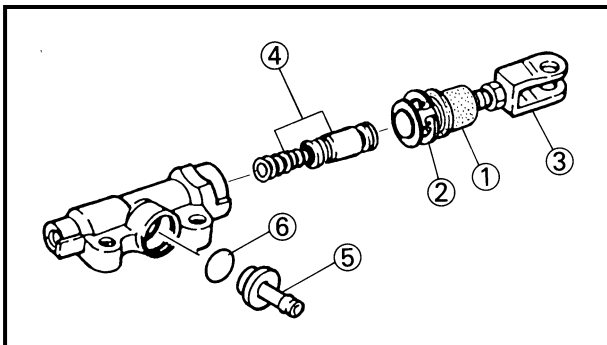

- 6.Remove:
- Dust boot ①
 - Circlip ②
 - Push rod ③
 - Master cylinder kit ④
 - Joint (brake hose) ⑤
 - O-ring ⑥

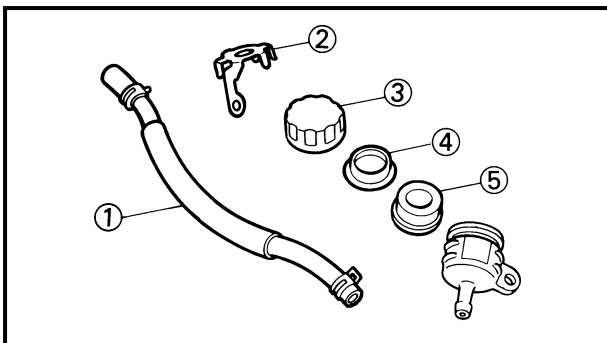

- 7.Remove:
- Brake hose ①
 - Cap stopper (reservoir tank) ②
 - Cap (reservoir tank) ③
 - Inner cap (reservoir tank) ④
 - Diaphragm ⑤



INSPECTION AND REPAIR

Recommended brake component replacement schedule:

Brake pads	As required
Piston seals	Every two years
Brake hoses	Every four years
Brake fluid	Replace only when brakes are disassembled.

⚠ WARNING

All internal parts should be cleaned in new brake fluid only. Do not use solvents as they will cause seals to swell and distort.

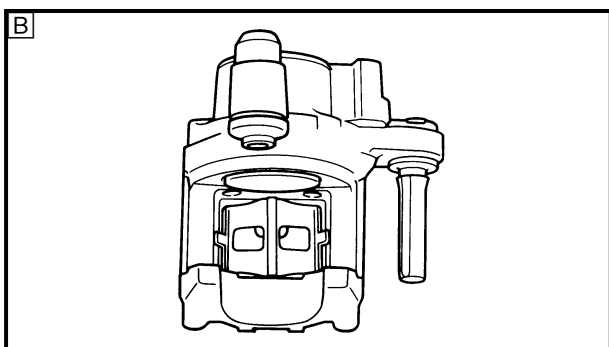
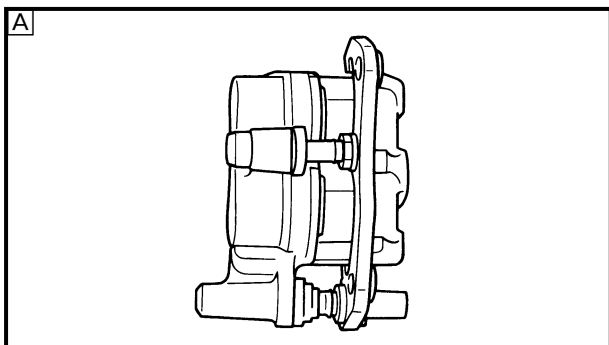

1. Inspect:

- Caliper cylinder
Wear/scratches → Replace the caliper assembly.
- Caliper piston
Scratches/rust/wear → Replace the caliper assembly.
- Caliper body
Cracks/damage → Replace the brake caliper assembly.
- Oil delivery passage (caliper body)
Blow out with compressed air.

A Front

B Rear

⚠ WARNING

Replace the piston seals whenever a caliper is disassembled.

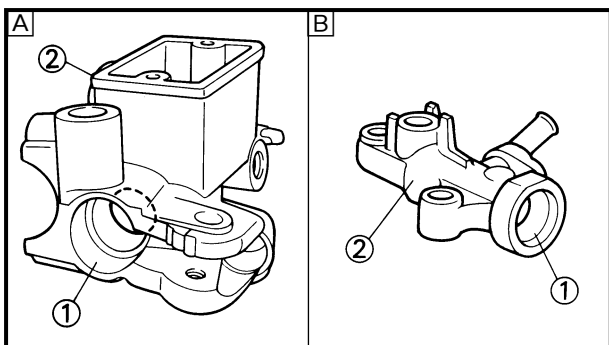

2. Inspect:

- Master cylinder ①
Wear/scratches → Replace the master cylinder assembly.
- Master cylinder bodies ②
Cracks/damage → Replace.
- Oil delivery passages (master cylinder bodies)
Blow out with compressed air.

A Front

B Rear

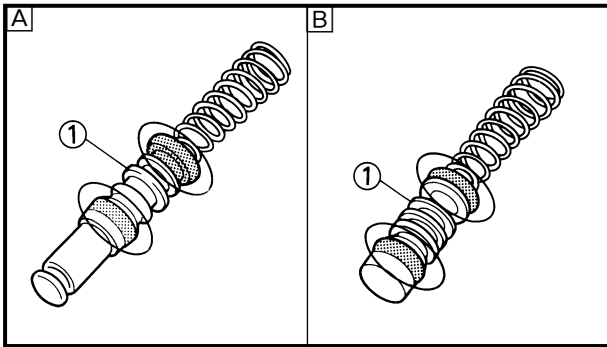

3. Inspect:

- Master cylinder kits ①
Scratches/wear/damage → Replace as a set.

- A Front
- B Rear

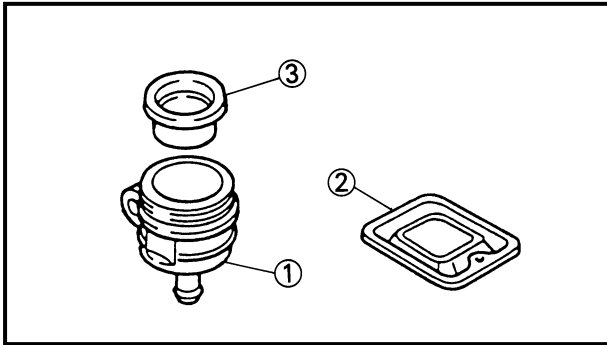

4. Inspect:

- Reservoir tank ① Cracks/damage → Replace.
- Diaphragm (front) ②
- Diaphragm (rear) ③
Wear/damage → Replace.

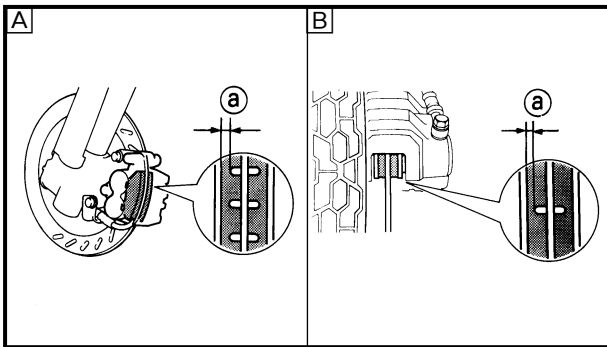

5. Inspect:

- Brake hoses (front, rear)
Cracks/wear/damage → Replace.

6. Measure:

- Brake pads (thickness @)
Out of specification → Replace.

- A Front
- B Rear



Wear limit:
1.0 mm (0.04 in)

NOTE:

- Replace the pad spring as a set if pad replacement is required.
- Replace the pads as a set if either is found to be worn to the wear limit.

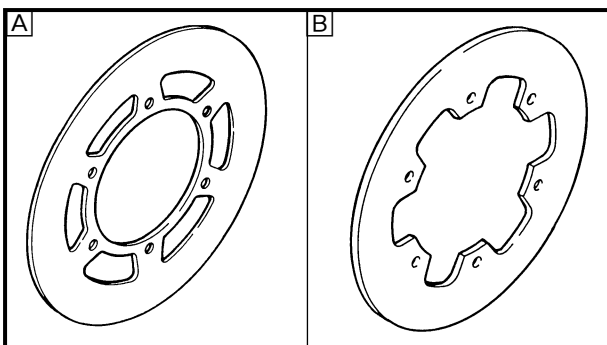

7. Inspect:

- Brake discs (front and rear)
Galling/damage → Replace.

- A Front
- B Rear

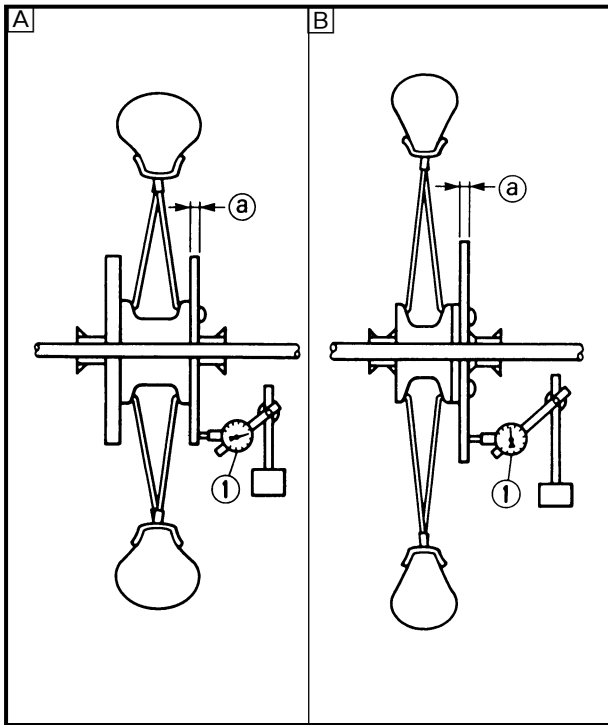

8.Measure:

- Brake disc deflection
Out of specification → Inspect wheel runout.
If the wheel runout is within the limits
replace the brake disc.

	Maximum deflection: 0.5 mm (0.020 in)
--	---

- ① Dial gauge
- Brake disc thickness @
Out of specification → Replace.

	Minimum thickness: Front: 3 mm (0.118 in) Rear: 4 mm (0.157 in)
--	--

NOTE: _____
Tighten the bolts (brake disc) in stage using
a crisscross pattern.

	Bolts (brake disc): Front: 12 Nm (1.2 m • kg, 8.7 ft • lb) LOCTITE® Rear: 12 Nm (1.2 m • kg, 8.7 ft • lb) LOCTITE®
--	---

CALIPER ASSEMBLY

⚠ WARNING _____

- All internal parts should be cleaned in
new brake fluid only.
- Internal parts should be lubricated with
brake fluid when installed.

	Brake fluid: DOT #4
--	-------------------------------

- Replace the piston seal and dust boot
whenever a caliper is disassembled.

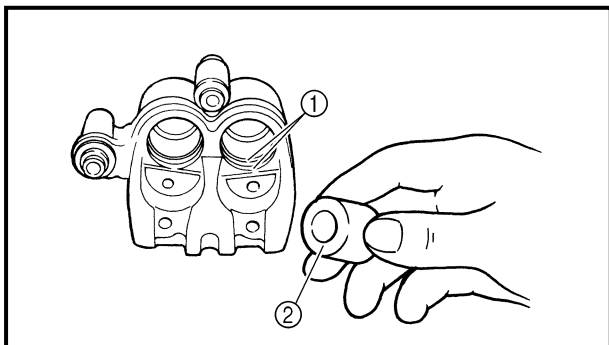

Front brake

1.Install:

- Piston seals ①
- Pistons ②

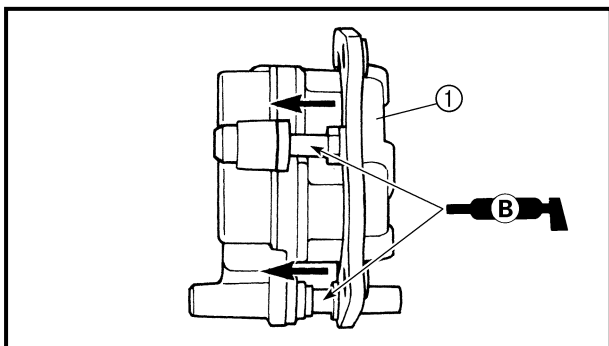

2.Install:

- Support bracket ①

NOTE:

Place the rubber boot securely in the groove of the guide pin when installing the caliper body.

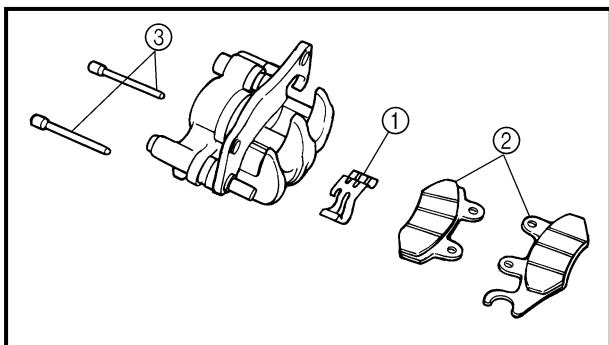

3.Install:

- Pad spring ①
- Brake pads ②
- Pad pins ③

Refer to "BRAKE PAD REPLACEMENT".

	<p>Pad pins ③: 18 Nm (1.8 m • kg, 13 ft • lb)</p>
--	--

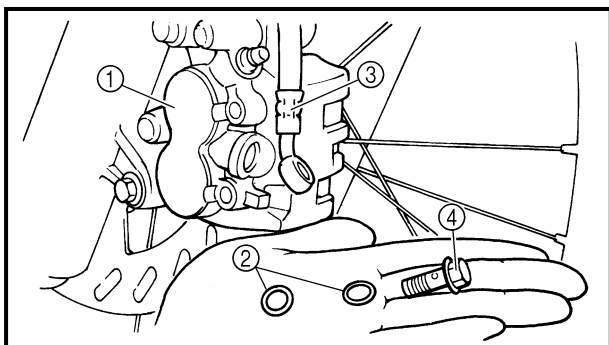

4.Install:

- Caliper ①
- Copper washers ②
- Brake hose ③
- Union bolt ④

	<p>Union bolt ④: 30 Nm (3.0 m • kg, 22 ft • lb)</p>
--	--

⚠ WARNING

- Proper hose routing is essential to insure safe motorcycle operation.
Refer to "CABLE ROUTING" in CHAPTER 2.
- Always use new copper washers.



5.Fill:

- Brake fluid

	<p>Recommended brake fluid: DOT #4</p>
--	---

C Brake fluid may erode painted surfaces or plastic parts. Always clean up spilled fluid immediately.

⚠ WARNING

- Use only the designated quality brake fluid: otherwise, the rubber seals may deteriorate, causing leakage and poor brake performance.
- Refill with the same type of brake fluid; mixing fluids may result in a harmful chemical reaction and lead to poor performance.
- Be careful that water does not enter the master cylinder when refilling. Water will significantly lower the boiling point of the fluid and may result in vapor lock.

6.Air bleed:

- Brake system
Refer to "AIR BLEEDING (HYDRAULIC BRAKE SYSTEM)" in CHAPTER 3.

7.Inspect:

- Brake fluid level
Fluid level is under "LOWER" level line ①
→ Fill up.
Refer to "BRAKE FLUID LEVEL INSPECTION" in CHAPTER 3.

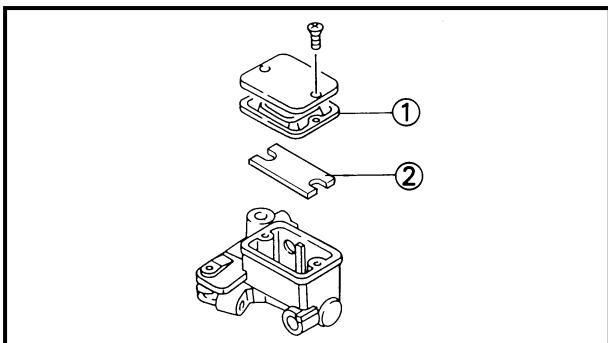
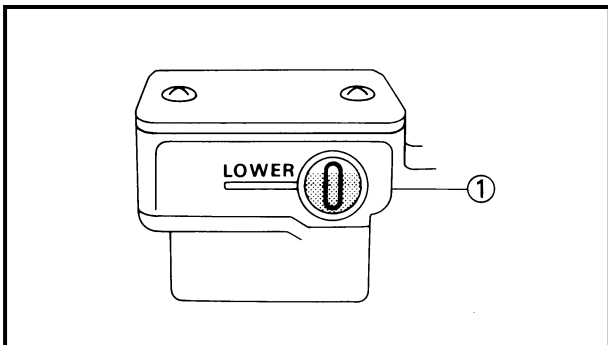

8.Install:

- Diaphragm ①
- Plate ②

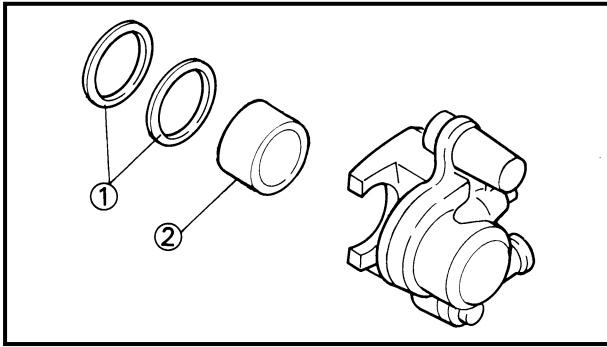

Rear brake

1.Install:

- Piston seals ①
- Caliper piston ②

⚠ WARNING

Always use new piston seals.

2.Install:

- Pad spring
- Brake pads (with pad shim)
- Pad pins

Refer to "BRAKE PAD REPLACEMENT".

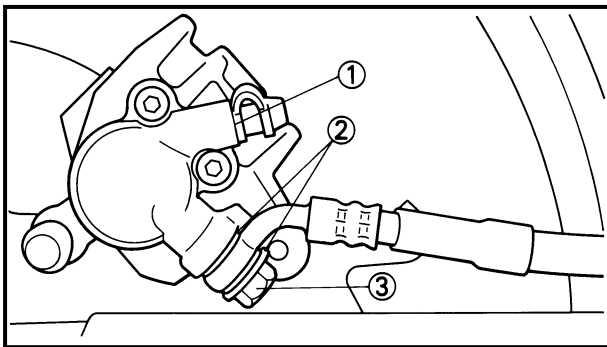

3.Install:

- Caliper assembly ①
- Copper washers ②
- Union bolt ③
- Rear wheel

Refer to "REAR WHEEL".



**Union bolt ③:
30 Nm (3.0 m · kg, 22 ft · lb)**

When installing the brake hose to the caliper, lightly touch the brake pipe with the projection on the caliper.

⚠ WARNING

- Proper hose routing is essential to insure safe motorcycle operation. Refer to "CABLE ROUTING" in CHAPTER 2.
- Always use new copper washers.



4.Fill:

- Brake fluid



**Recommended brake fluid:
DOT #4**

C

Brake fluid may erode painted surfaces or plastic parts. Always clean up spilled fluid immediately.

⚠ WARNING

- **Use only the designated quality brake fluid: otherwise, the rubber seals may deteriorate, causing leakage and poor brake performance.**
- **Refill with the same type of brake fluid: mixing fluids may result in a harmful chemical reaction and lead to poor performance.**
- **Be careful that water does not enter the master cylinder when refilling. Water will significantly lower the boiling point of the fluid and may result in vapor lock.**

5.Air bleed:

- Brake system

Refer to "AIR BLEEDING (HYDRAULIC BRAKE SYSTEM)" in CHAPTER 3.

6.Inspect:

- Brake fluid level

Fluid level is under "LOWER" level line → Replenish.

Refer to "BRAKE FLUID LEVEL INSPECTION" in CHAPTER 3.

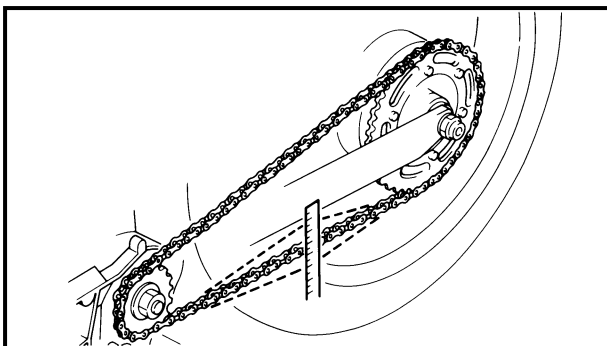

7.Adjust:

- Drive chain slack



**Drive chain slack:
35 ~ 50 mm (1.38 ~ 1.97 in)**

Refer to "DRIVE CHAIN SLACK ADJUSTMENT" in CHAPTER 3.



MASTER CYLINDER ASSEMBLY

⚠ WARNING

- All internal parts should be cleaned in new brake fluid only.
- Internal parts should be lubricated with brake fluid when installed.



Brake fluid:
DOT #4

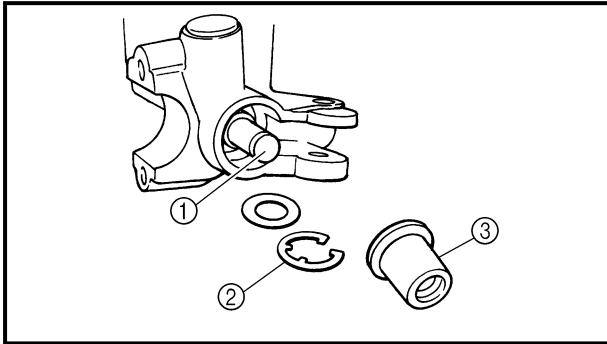

Front brake

1.Install:

- Master cylinder kit ①
- Circlip ②
- Rubber boot ③
- Plate ④

NOTE:

When installing the plate ④, push it in securely to the shown position.

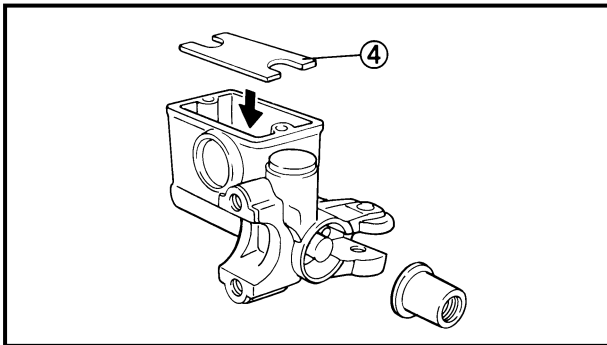

2.Install:

- Master cylinder ①

NOTE:

- Install the master cylinder bracket with the "UP" mark facing upward.
- Tighten first the upper bolt, then the lower bolt.

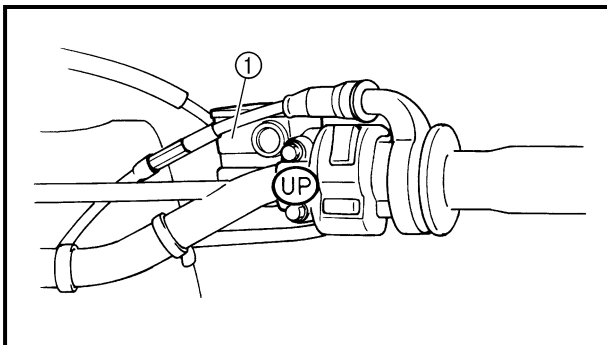

Bolt (master cylinder bracket):
7 Nm (0.7 m • kg, 5.1 ft • lb)

3.Install:

- Copper washers ②
- Brake hose ③
- Union bolt ④



Union bolt ④:
30 Nm (3.0 m • kg, 22 ft • lb)

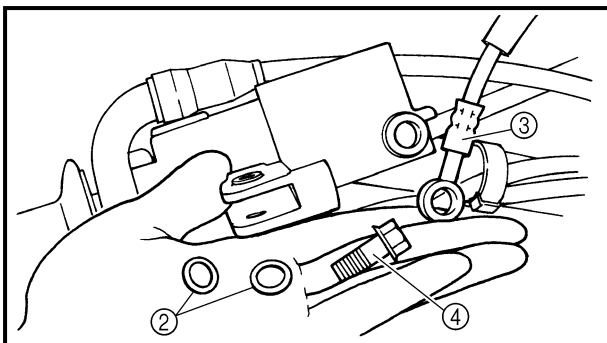



NOTE: _____
Install the brake hose as shown.

⚠ WARNING _____

- **Proper hose routing is essential to insure safe motorcycle operation.**
Refer to "CABLE ROUTING" in CHAPTER 2.
- **Always use new copper washers.**

4. Install:

- Brake switch
- Spring
- Brake lever
- Brake lever cover
- Mirror (right)

NOTE: _____
Apply lithium soap base grease to the pivot shaft of the brake lever.

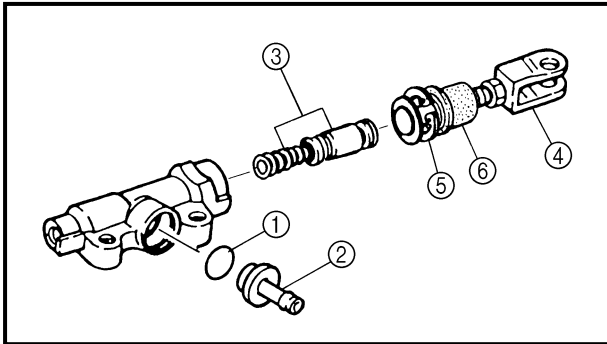

Rear brake

1. Install:

- O-ring ①
- Joint (brake hose) ②
- Master cylinder kit ③
- Push rod ④
- Circlip ⑤
- Dust boot ⑥

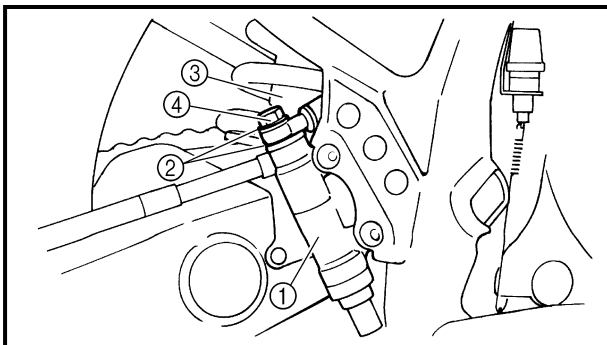

2. Install:

- Master cylinder ①
- Copper washers ②
- Brake hose ③
- Union bolt ④

	Bolts (master cylinder):
	23 Nm (2.3 m • kg, 17 ft • lb)
	Union bolt ④:
	30 Nm (3.0 m • kg, 22 ft • lb)

NOTE: _____
When installing the brake hose to the master cylinder, make sure the brake pipe lightly touches the projection on the copper washer (lower).

⚠ WARNING

- Proper hose routing is essential to insure safe motorcycle operation. Refer to "CABLE ROUTING" in CHAPTER 2.
- Always use new copper washers.

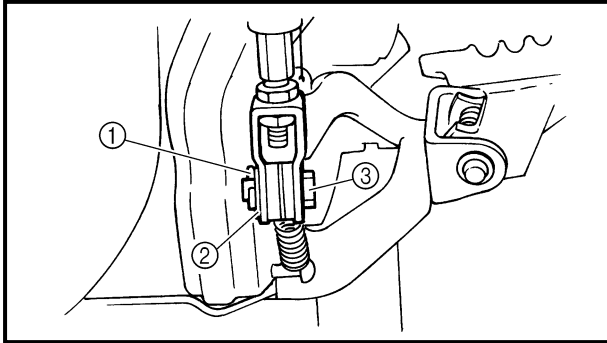

3. Install:

- Pin ①
- Washer ②
- Cotter pin ③

⚠ WARNING

Always use a new cotter pin.

4. Install:

- Reservoir tank

NOTE:

At this time, temporarily install the reservoir tank without its cap and cap stopper.

5. Connect:

- Brake hose

6. Fill:

- Brake fluid



Recommended brake fluid:
DOT #4

CA

Brake fluid may erode painted surface or plastic parts. Always clean up spilled fluid immediately.

⚠ WARNING

- Use only the designated quality brake fluid: otherwise, the rubber seals may deteriorate, causing leakage and poor brake performance.
- Refill with the same type of brake fluid: mixing fluids may result in a harmful chemical reaction and lead to poor performance.
- Be careful that water does not enter the master cylinder when refilling. Water will significantly lower the boiling point of the fluid and may result in vapor lock.



7. Air bleed:

- Brake system

Refer to "AIR BLEEDING (HYDRAULIC BRAKE SYSTEM)" in CHAPTER 3.

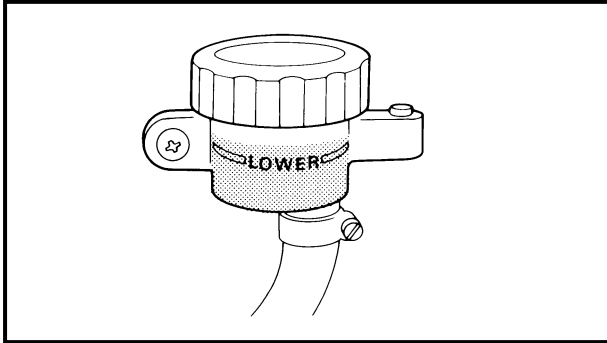

8. Inspect:

- Brake fluid level

Fluid level is under the "LOWER" level line → Replenish.

Refer to "BRAKE FLUID LEVEL INSPECTION" in CHAPTER 3.

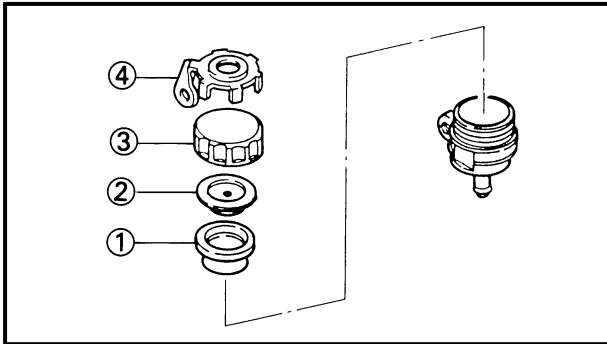

9. Install:

- Diaphragm ①
- Holder (diaphragm) ②
- Cap (reservoir tank) ③
- Stopper (reservoir tank cap) ④
- Reservoir tank

10. Adjust:

- Rear brake pedal height

**Pedal height:**

10 mm (0.394 in)

(below the top of the footrest)

Refer to "REAR BRAKE ADJUSTMENT" in CHAPTER 3.



FRONT FORK

- ① Front fork assembly (left)
- ② Cap bolt
- ③ Upper seat
- ④ Collar
- ⑤ Lower seat
- ⑥ Fork spring
- ⑦ Locknut
- ⑧ Piston rod
- ⑨ Rebound spring
- ⑩ Damper rod
- ⑪ Inner tube
- ⑫ Piston metal
- ⑬ Retaining clip
- ⑭ Dust seal
- ⑮ Oil seal
- ⑯ Plain washer
- ⑰ Slide metal
- ⑱ Oil lock pieces
- ⑲ Brake hose holder
- ⑳ Base valve assembly
- ㉑ Cap
- ㉒ Front fork assembly (right)
- ㉓ Axle holder
- ㉔ Boot

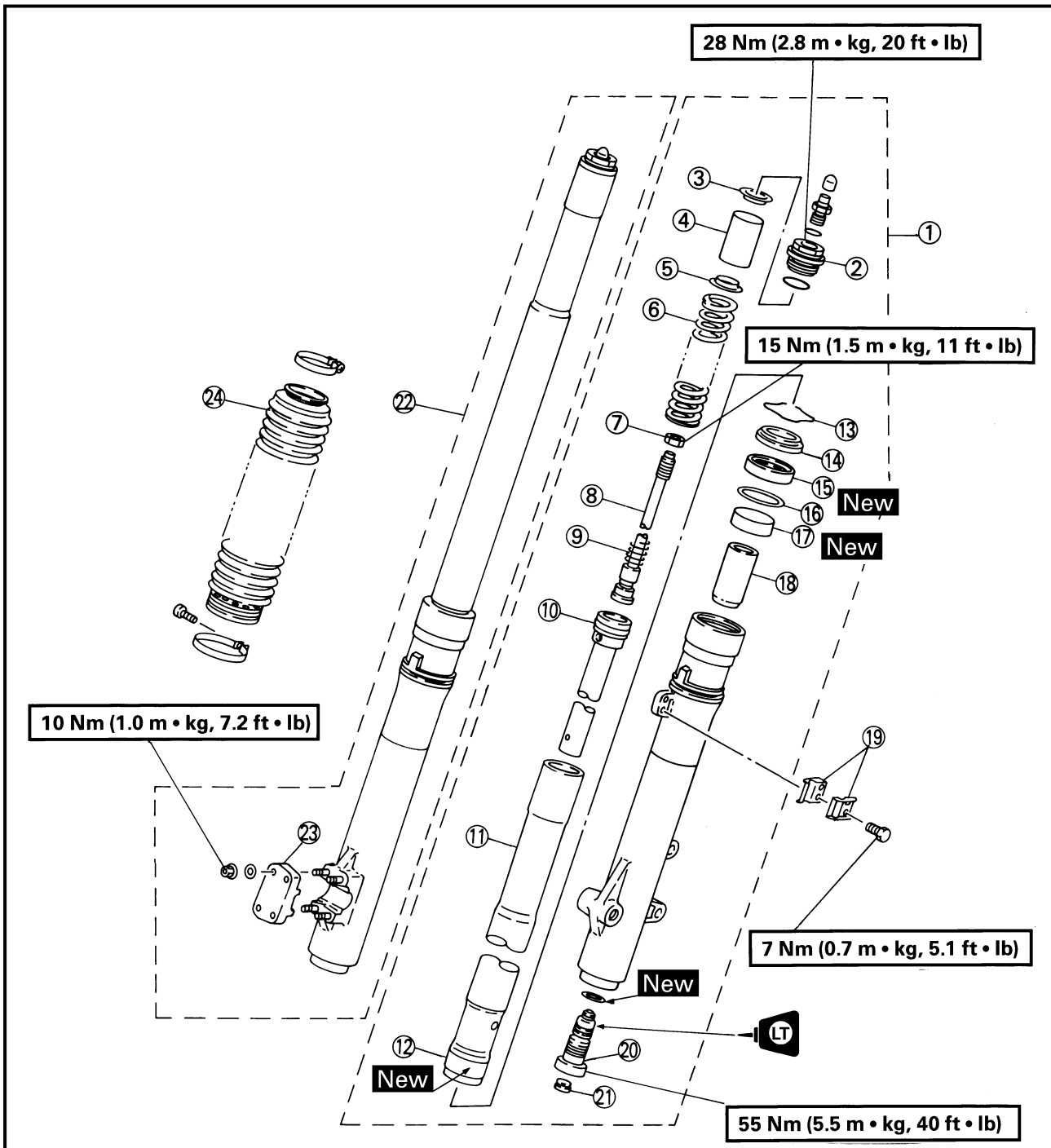



REMOVAL

⚠ WARNING

Support the motorcycle securely so there is no danger of it falling over.

1. Place the motorcycle on a level place.
2. Elevate the front wheel by placing a suitable stand under the frame and engine.

3. Remove:

- Front wheel
Refer to "FRONT WHEEL".

4. Remove:

- Holder ① (brake hose)
- Bolts ② (brake caliper)

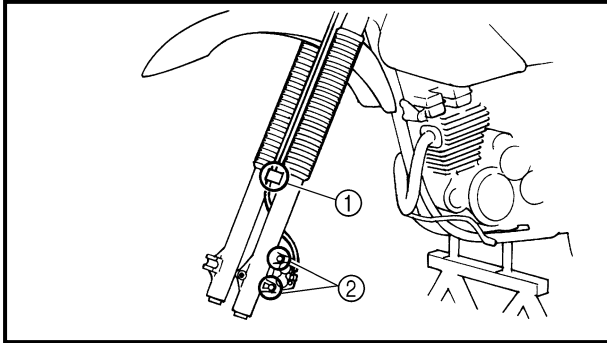

5. Loosen:

- Cap bolt ①

NOTE:

Before loosening the cap bolt, the fork legs must be bled by pushing the air valve ②.

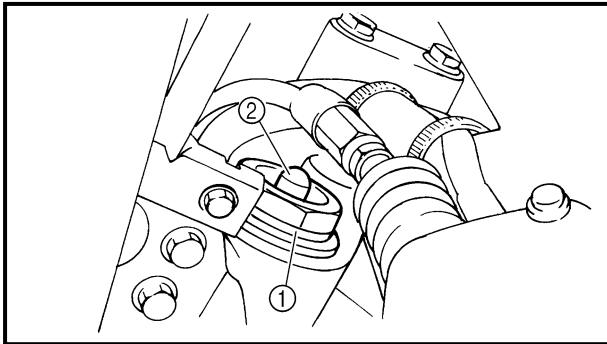

6. Loosen:

- Pinch bolts ① (handlebar crown)
- Pinch bolts ② (lower bracket)

⚠ WARNING

Support the fork before loosening the pinch bolt.

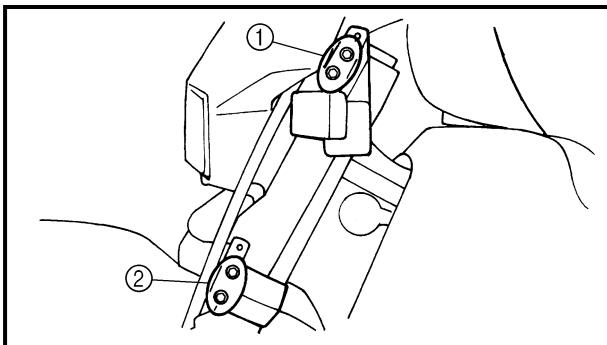

7. Remove:

- Front fork
- Fork boot ①

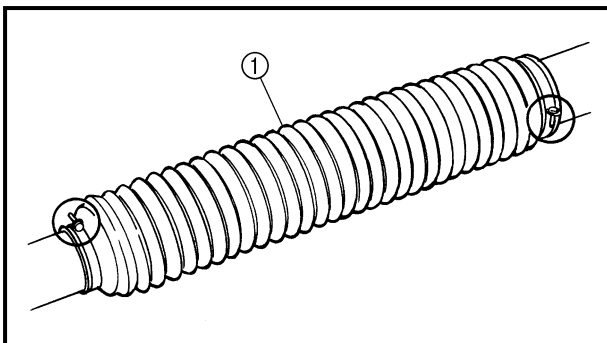

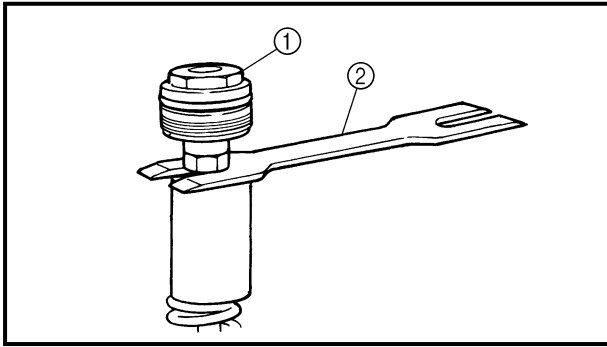

DISASSEMBLY

- 1.Remove:
 - Cap bolt (from the inner tube)
- 2.Remove:
 - Cap bolt ① (from the piston rod)

NOTE: _____
 Remove the cap bolt using the rod holder ②.



Rod holder:
P/N. YM-01434

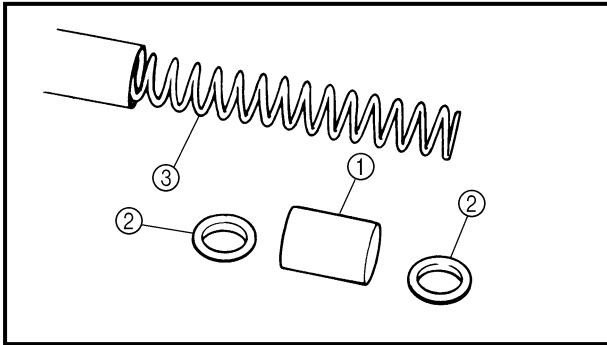

- 3.Remove:
 - Collars ①
 - Spring seats ②
 - Fork spring ③
- 4.Drain:
 - Fork oil

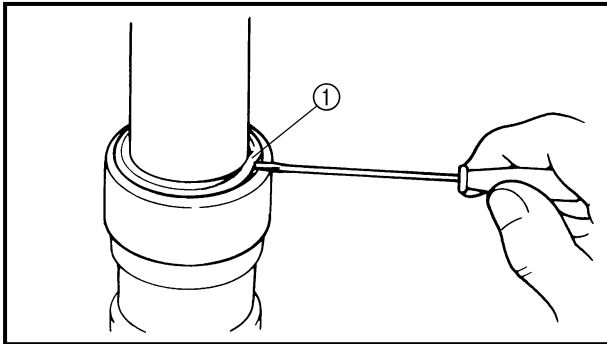

- 5.Remove:
 - Retaining clip ①

NOTE: _____
 Use a thin screwdriver, and be careful not to scratch the inner fork tube.

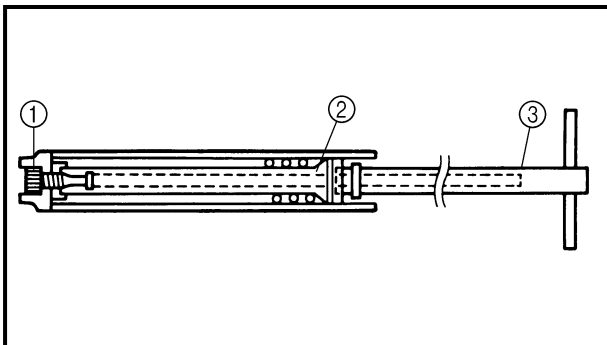

- 6.Remove:
 - Base valve ①
 - Damper rod assembly ②
 - Damper rod holder ③

NOTE: _____
 When loosening the base valve ① (damper rod ②), the damper rod must be held with the damper rod holder ③.



Damper rod holder:
P/N. YM-01418

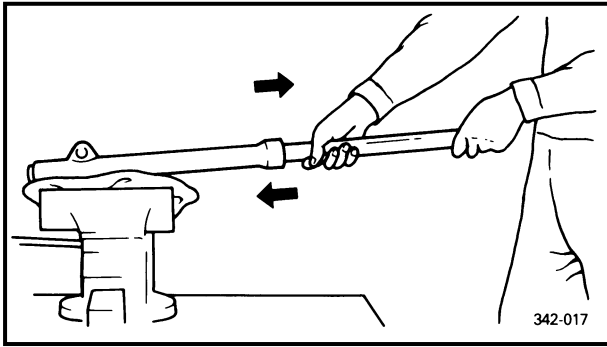

7.Remove:

- Inner fork tube

Removal steps:

- Hold the fork leg horizontally.
- Clamp the caliper mounting boss of the outer fork tube securely in a vise with soft jaws.
- Separate the inner tube from the outer tube by pulling forcefully but carefully on the inner tube.

C

- **Excessive force will damage the oil seal and/or the slide and piston metals. Damaged oil seal, slide metal and piston metal must be replaced.**
- **Avoid bottoming the inner fork tube in the outer fork tube during the above procedure, as the oil lock piece will be damaged.**

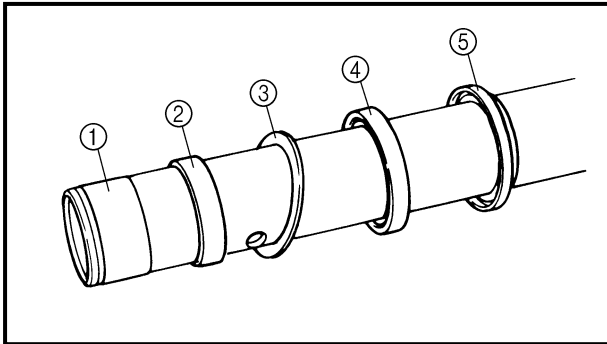

8.Remove:

- Piston metal ①
- Slide metal ②
- Plain washer ③
- Oil seal ④
- Dust seal ⑤
- Oil lock piece

INSPECTION

1.Inspect:

- Inner fork tube ①
 - Outer fork tube ②
- Scratches/bends/damage → Replace.

⚠ WARNING

Do not attempt to straighten a bent inner fork tube as this may dangerously weaken the tube.

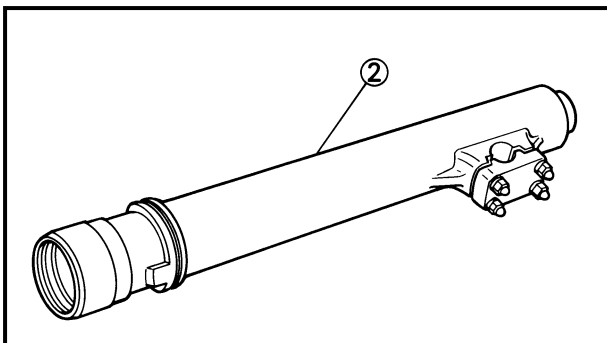
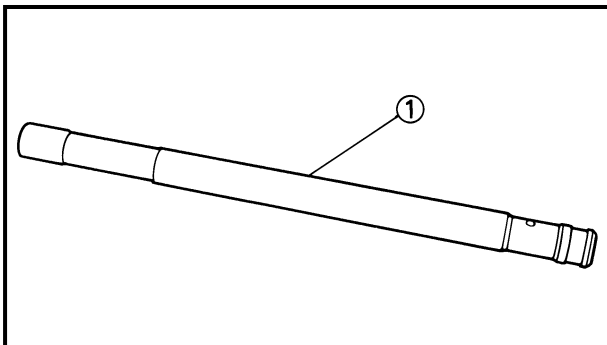

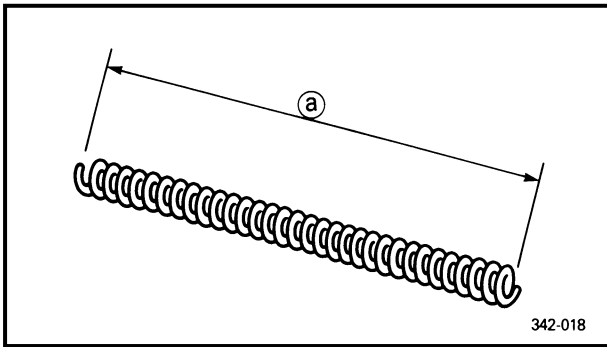

2.Measure:

- Fork spring free length ①
Out of specification → Replace.



Fork spring free length:
472 mm (18.58 in)
Minimum free length:
462 mm (18.19 in)

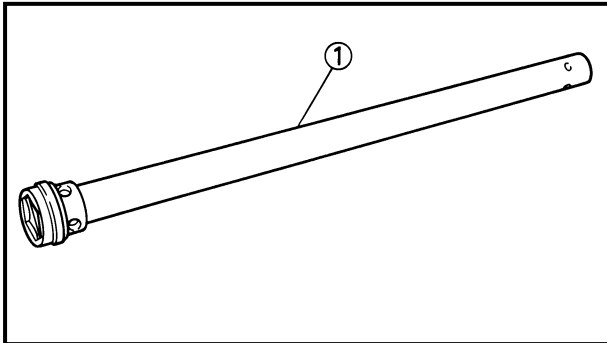

3.Inspect:

- Damper rod ①
Wear/bends/damage → Replace.
Contamination → Blow out all oil passages with compressed air.

⚠ WARNING

Do not attempt to straighten a bent damper rod as this may dangerously weaken the rod.

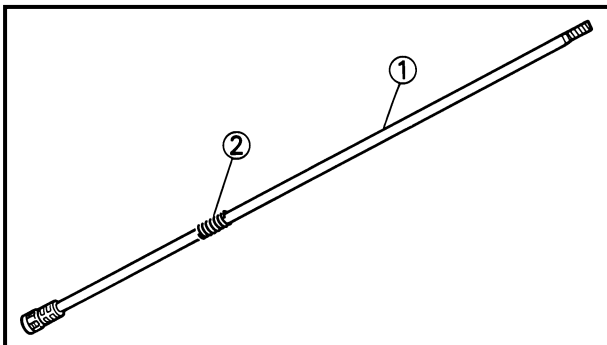

4.Inspect:

- Piston rod ①
- Rebound spring ②
Wear/bends/damage → Replace.

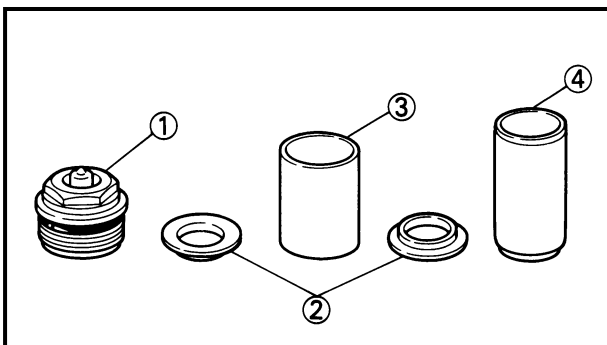

5.Inspect:

- Cap bolt ①
- Spring seats ②
- Spacer ③
- Oil lock piece ④
Damage → Replace.

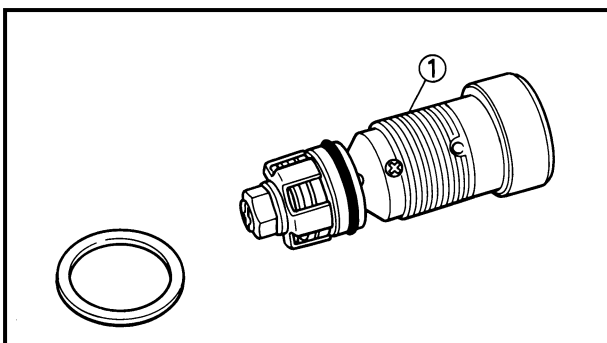

6.Inspect:

- Base valve ①
Damage → Replace.
Contamination → Blow out all oil passages with compressed air.

**ASSEMBLY**

Reverse the "DISASSEMBLY" procedure.
Note the following points.

NOTE:

- When assembling the front fork, be sure to replace the following parts.
 - * Piston metal
 - * Slide metal
 - * Oil seal
 - * Dust seal
- Make sure all components are clean before assembling the fork.

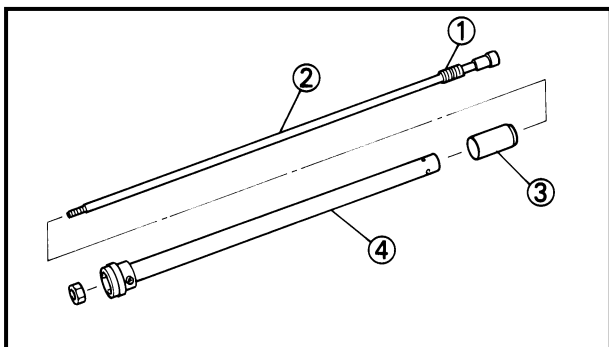
**1.Install:**

- Rebound spring ①
- Piston rod ②
- Oil lock piece ③
- Damper rod ④

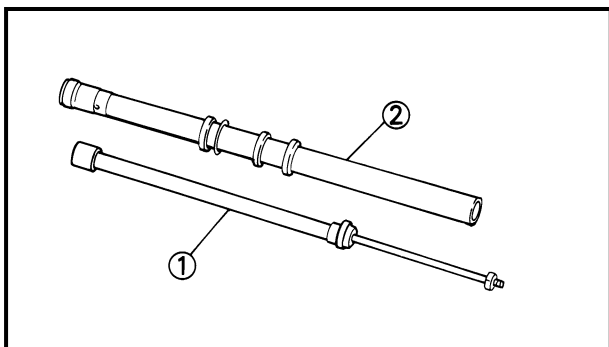
**2.Install:**

- Damper rod assembly ①
(to the inner tube ②)

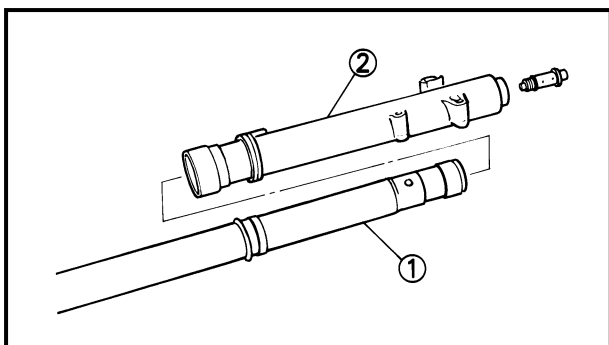
**3.Install:**

- Inner fork tube ①
(to the outer fork tube ②)

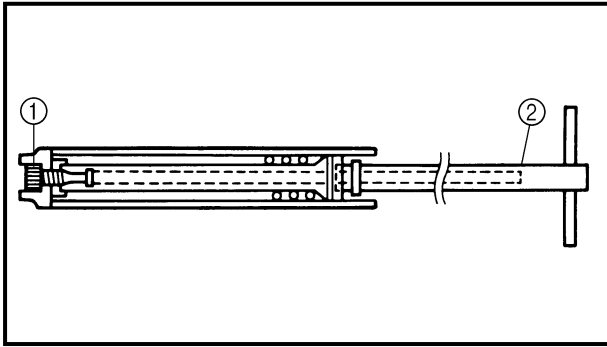

4. Tighten:

- Base valve ① (damper rod)

Use the damper rod holder ② to hold the damper rod.



Damper rod holder:
YM-01418



Base valve (damper rod):
55 Nm (5.5 m · kg, 40 ft · lb)
LOCTITE®

⚠ WARNING

Always use a new copper washer.

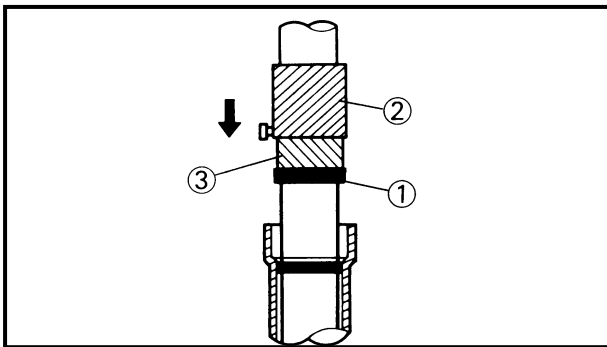

5. Install:

- Oil seal ①

Use the fork seal driver weight ② and adapter ③.



Fork seal driver weight:
YM-33963

Adapter:
43 mm (1.69 in):
YM-8020

NOTE:

Before installing the oil seal, apply the lithium soap base grease onto the oil seal lips.

C

Be sure that the oil seal numbered side faces upward.

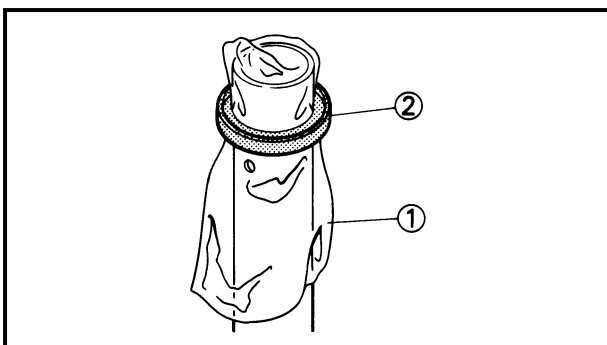

NOTE:

- Apply fork oil on the inner tube.
- When installing the oil seal and dust seal ②, use a plastic sheet ① lubricated with fork oil to protect the oil seal lip.
- Install the oil seal with its manufacturer's marks or number facing the axle holder side.

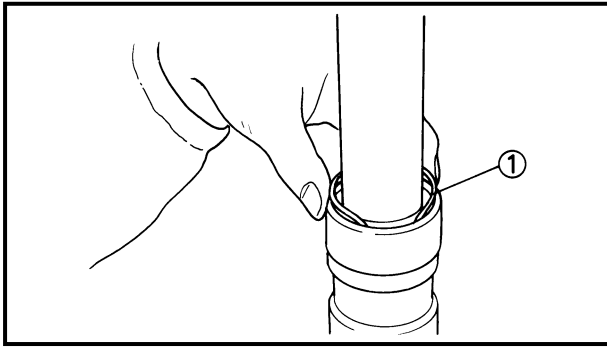

6.Install:

- Retaining clip

NOTE:

Fit the oil seal retaining clip ① correctly in the groove of the outer fork tube.

7.Fill:

- Front fork oil

To the top of the inner tube with the recommended fork oil.



Fork oil capacity:

555 cm³

(19.57 Imp oz, 18.76 US oz)

Recommended oil:

Yamaha suspension oil 01 or equivalent

- **Be sure to use the recommended fork oil. If other oils are used, they may have an adverse effect on the front fork performance.**
- **NEVER allow foreign materials to enter the front fork.**

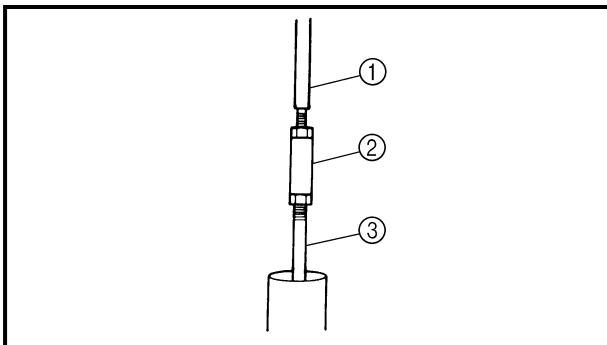

8.Attach:

- Rod puller ①
- Rod puller attachment ② (to damper rod ③)



Rod puller:

P/N. YM-01437

Rod puller attachment:

P/N. 90890-01436

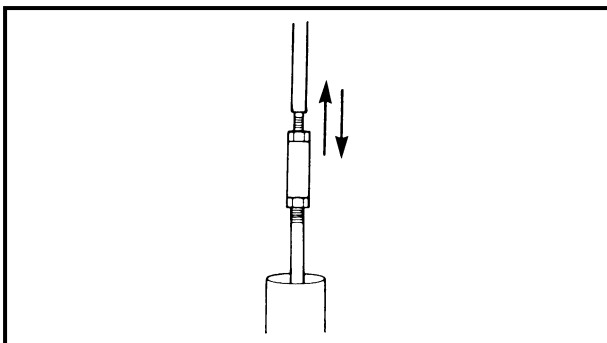

9.After filling the front fork leg, pump the damper rod ③ slowly up and down more than 10 times to distribute the fork oil.

NOTE:

Be sure to pump the damper rod slowly because the fork oil may spurt out.



10. After filling, pump the inner tube slowly up and down (about 150 mm (5.90 in)) to distribute the fork oil once more.

NOTE:

Be careful not to stroke the inner tube over. A stroke of 150 mm (5.90 in) or more will cause air to enter. In this case, repeat the steps 8 to 9.

11. Wait ten minutes until the air bubbles have dispersed from the front fork, and the oil has been distributed evenly in the system before setting the recommended oil level.

NOTE:

Pour the fork oil up to the top of the inner tube to ensure that it spreads to all its parts. Failing to do so will make it impossible to obtain the correct level.

Be sure to bleed the front forks after filling them with oil.

12. Measure:

- Oil level (left and right) @
Out of specification → Adjust.



Fork oil level @:
130 mm (5.12 in)

From the top of the outer tube with inner tube and damper rod ① fully compressed without spring.

⚠ WARNING

Never fail to fill to the specified oil level @ and always make sure to adjust each front fork leg to the same level. Uneven adjustment can cause poor handling and loss of stability.

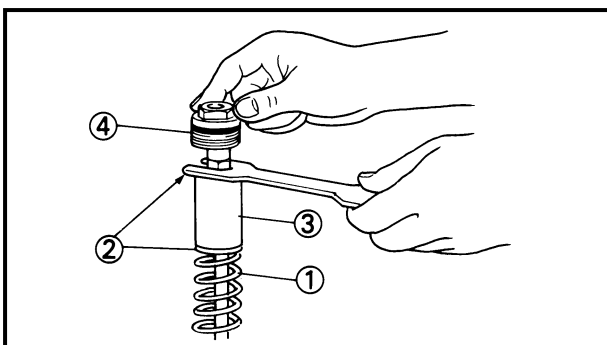
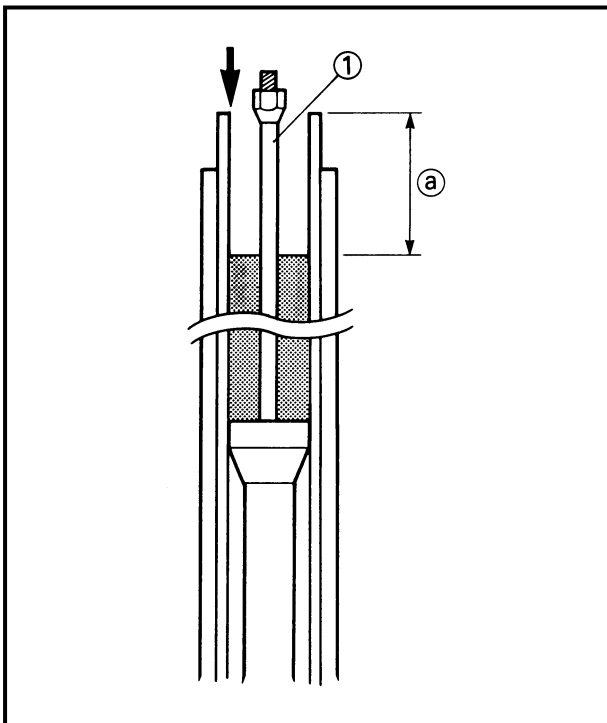

13. Install:

- Fork spring ①
- Spring seats ②
- Collar ③
- Cap bolt ④

Fully tighten with your finger.

14. Tighten:

- Locknut

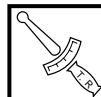

Nut:
15 Nm (1.5 m • kg, 11 ft • lb)

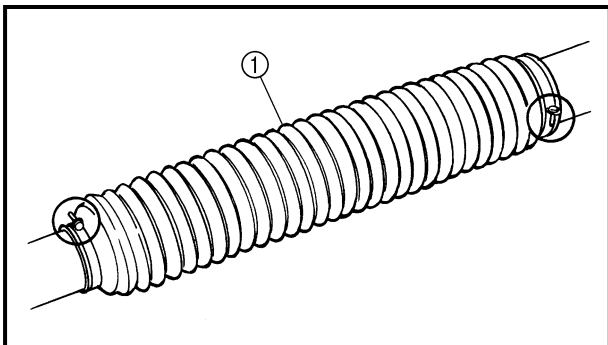
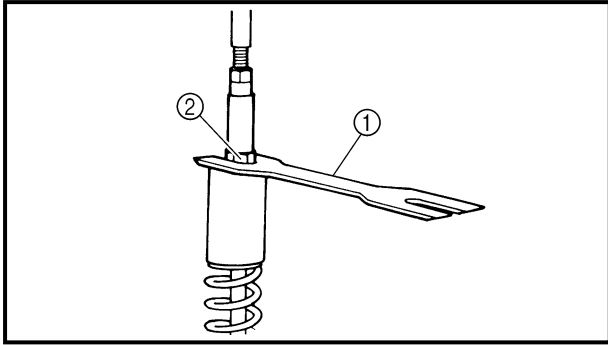
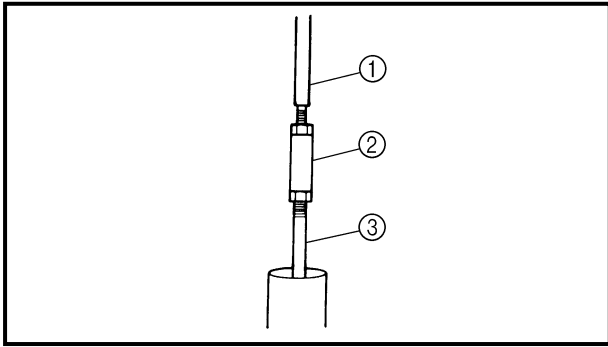

Installing steps:

- Install the rod puller ① and attachment ② to the damper rod ③.



Rod puller:
P/N. YM-01437
Rod puller attachment:
P/N. 90890-01436

- Install the fork spring, spring seats and collars.
- Pull up the rod puller and set the rod holder ① between the locknut ② and spring seat.

NOTE: _____
Use the "B" -marked side of rod holder.



Rod holder:
P/N. YM-01434

- Remove the rod puller and attachment.
- Temporarily install the cap bolt.
- Tighten the locknut.



Locknut ②:
15 Nm (1.5 m • kg, 11 ft • lb)

- Remove the rod holder.

NOTE: _____
Be careful, this fork spring is compressed.

15. Install:
 - Inner tube (to cap bolt)
Temporarily tighten the cap bolt.
16. Install:
 - Fork boot ①

INSTALLATION

Reverse the "REMOVAL" procedure.
Note the following points.

1. Install:
 - Front fork
Temporarily tighten the pinch bolts.

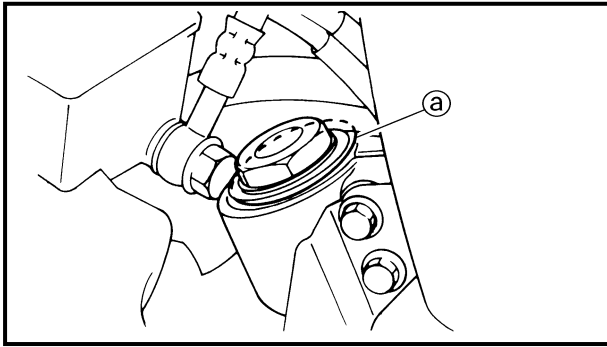

NOTE: _____
 Position the inner fork tube end in such a way that it is flush ① with the top of the handle crown.

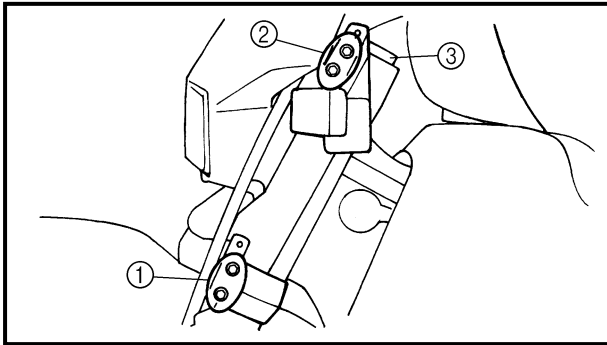

- 2.Tighten:
- Pinch bolts ① (lower bracket)
 - Pinch bolts ② (handlebar crown)
 - Cap bolt ③

	Pinch bolt ① (lower bracket): 30 Nm (3.0 m • kg, 22 ft • lb)
	Pinch bolts ② (handlebar crown): 23 Nm (2.3 m • kg, 17 ft • lb)
	Cap bolt ③: 28 Nm (2.8 m • kg, 20 ft • lb)

- 3.Install:
- Bolt (brake caliper)
 - Holder (brake hose)

	Bolt (brake caliper): 23 Nm (2.3 m • kg, 17 ft • lb)
	Bolt (brake hose holder): 7 Nm (0.7 m • kg, 5.1 ft • lb)

⚠ WARNING _____

Proper hose routing is essential to insure safe motorcycle operation. Refer to "CABLE ROUTING" in CHAPTER 2.

- 4.Install:
- Front wheel

	Bolt (wheel axle): 58 Nm (5.8 m • kg, 42 ft • lb)
--	---

Refer to "FRONT WHEEL".

- 5.Adjust:
- Air pressure
 Refer to "FRONT FORK ADJUSTMENT" in CHAPTER 3.

	Standard air pressure: 0 kPa (0 kg/cm ² , 0 psi)
	Maximum air pressure: 40 kPa (0.4 kg/cm ² , 5.7 psi)



STEERING HEAD AND HANDLEBAR

- ① Handlebar holder (upper)
- ② Handlebar holder (lower)
- ③ Headlight stay 2
- ④ Cap
- ⑤ Handlebar crown
- ⑥ Headlight stay 1
- ⑦ Brake hose holder
- ⑧ Lock washer
- ⑨ Ring nut
- ⑩ Damper collar
- ⑪ Washer
- ⑫ Cover
- ⑬ Washer
- ⑭ Bearing (upper)
- ⑮ Bearing (lower)
- ⑯ Steering shaft
- ⑰ Stay

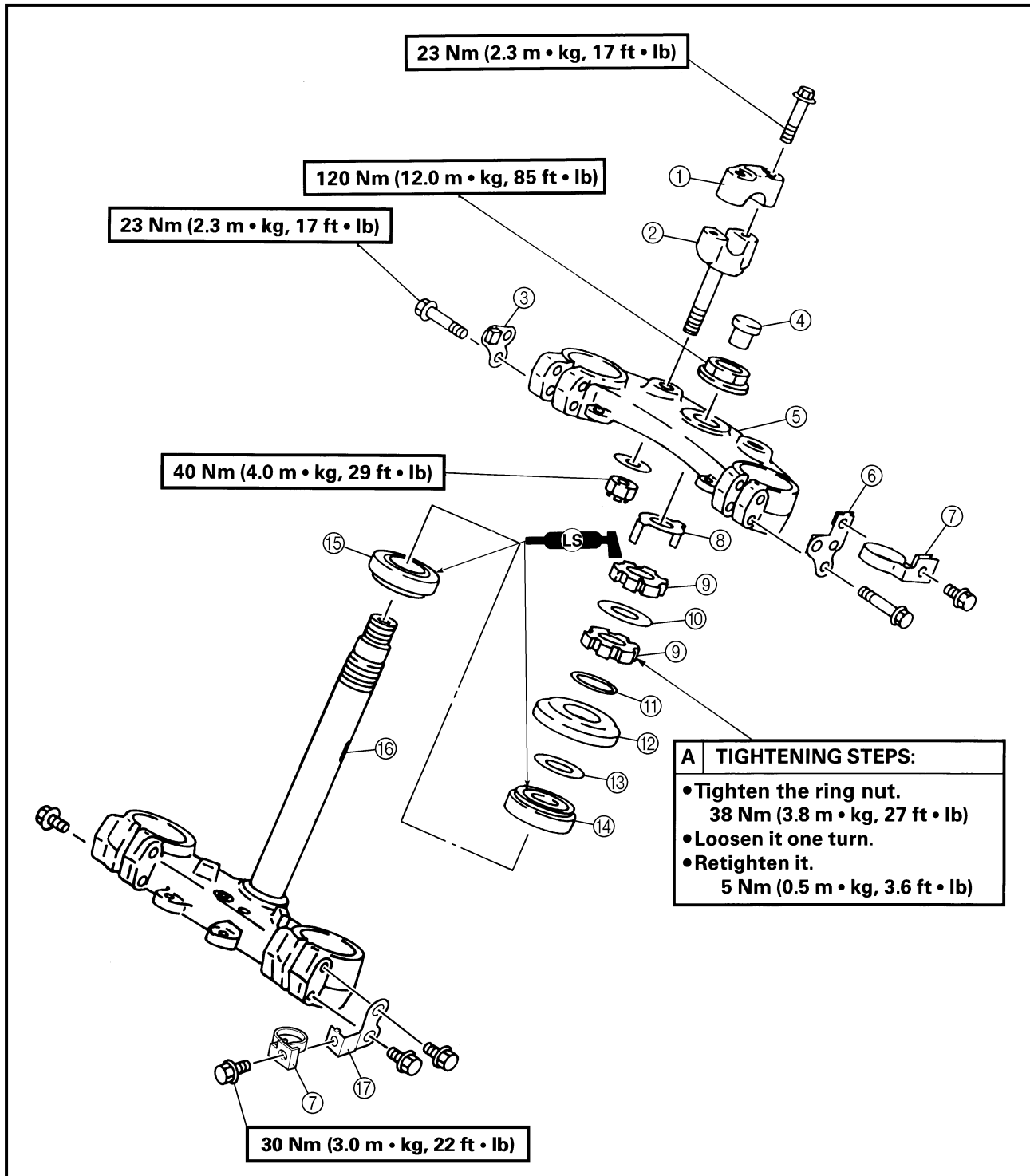

STEERING HEAD AND HANDLEBAR

CHAS



- ① Handlebar grip (right)
- ② Leaf ring
- ③ Throttle guide tube
- ④ Handlebar
- ⑤ Handlebar grip (left)
- ⑥ Throttle cable holder (front)
- ⑦ Throttle cable holder (rear)
- ⑧ Boot
- ⑨ Throttle cable 1
- ⑩ Throttle cable 2
- ⑪ Clutch cable
- ⑫ Boot
- ⑬ Brush guard (left)
- ⑭ Brush guard (right)

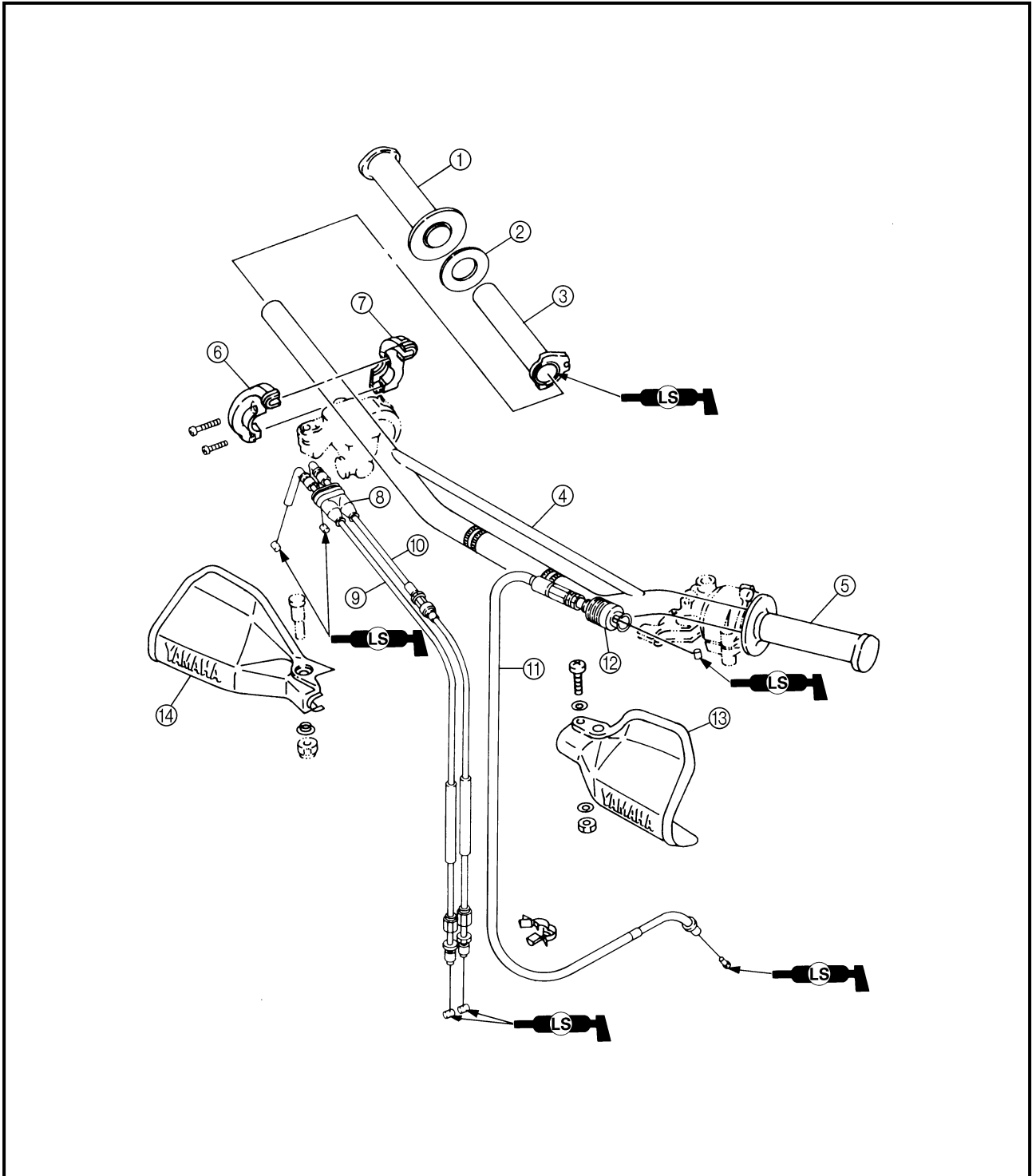



REMOVAL Handlebar

⚠ WARNING

Securely support the motorcycle so there is no danger of it falling over.

1. Place the motorcycle on a level place.

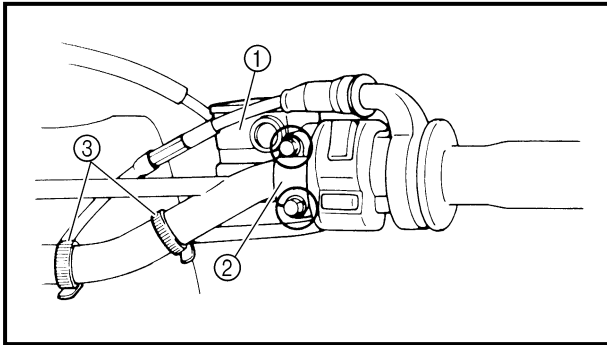

2. Remove:

- Master cylinder assembly ①
- Master cylinder bracket ②
- Bands ③

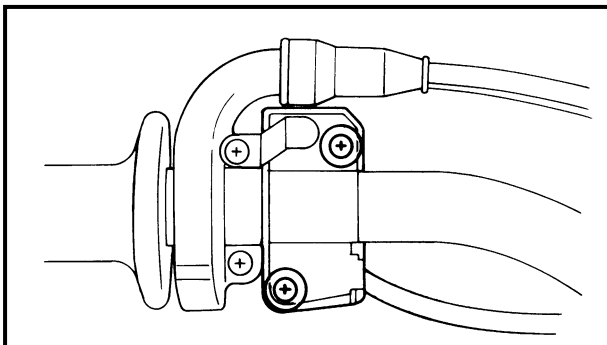

3. Remove:

- Handlebar switch (right)

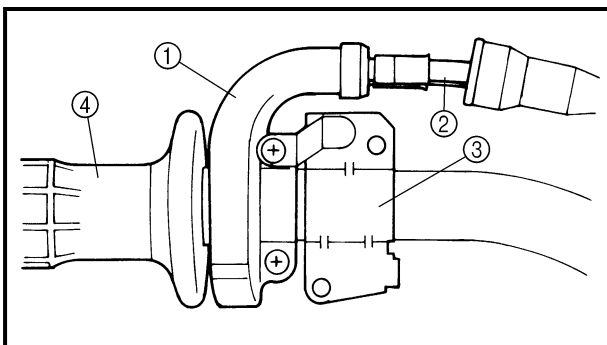

4. Remove:

- Throttle cable holder ①
- Throttle cable ②
- Plate ③
- Throttle grip ④

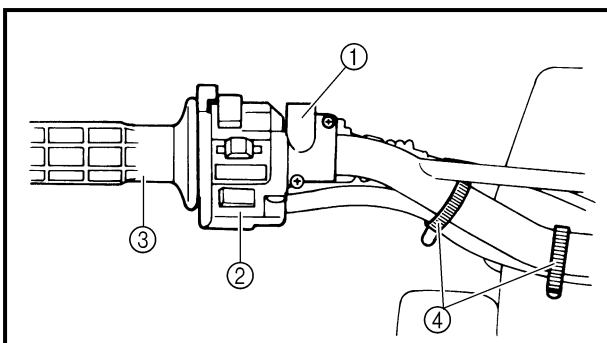

5. Remove:

- Lever holder ①
- Handlebar switch ② (left)
- Grip ③
- Bands ④

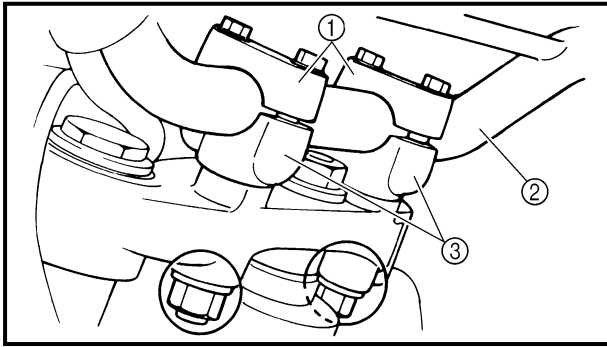

- 6.Remove:
- Handlebar upper holder ①
 - Handlebar ②
 - Handlebar lower holder ③

Steering head

⚠ WARNING

Securely support the motorcycle so there is no danger of it falling over.

- 1.Place the motorcycle on a level place.
- 2.Elevate the front wheel by placing a suitable stand under the frame and engine.

- 3.Remove:
- Handlebar
Refer to "Handlebar".
- 4.Remove:
- Front wheel
Refer to "FRONT WHEEL".

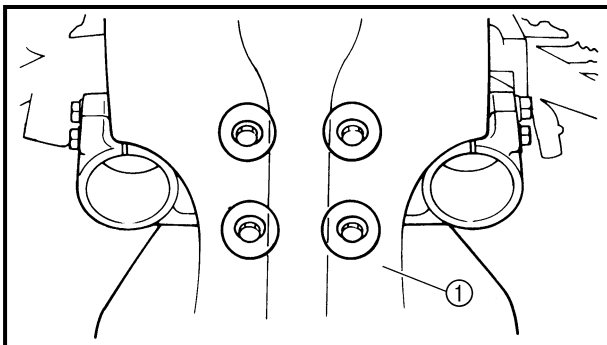

- 5.Remove:
- Front fork
Refer to "FRONT FORK".

- 6.Remove:
- Front fender ①

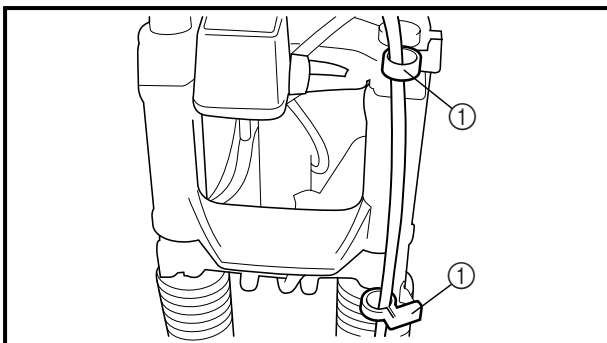

- 7.Remove:
- Holder ① (brake hose)
- 8.Disconnect:
- Speedometer cable

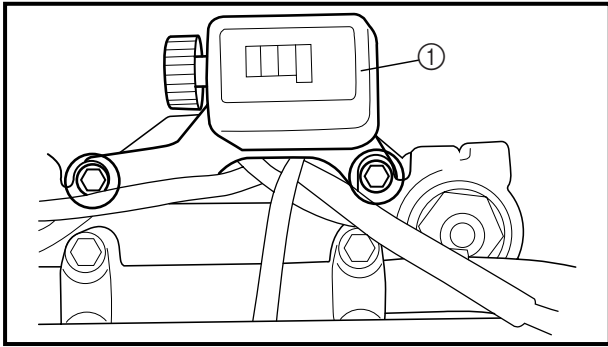

- 9.Remove:
- Speedometer assembly ①

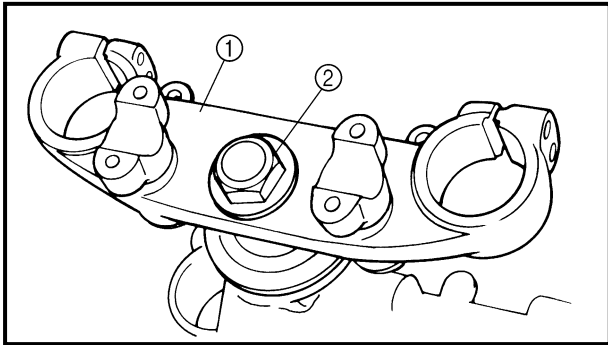

- 10.Remove:
- Handlebar crown ①

NOTE: _____
Loosen the steering stem nut ② and remove the handlebar crown ①. Take care that the handlebar crown does not touch the fuel tank.

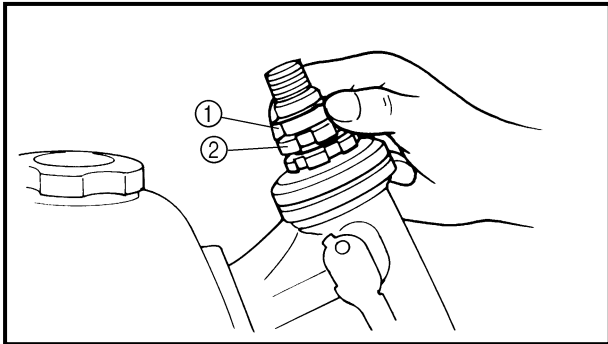

- 11.Remove:
- Lock washer ①
 - Ring nut ②
 - Rubber washer

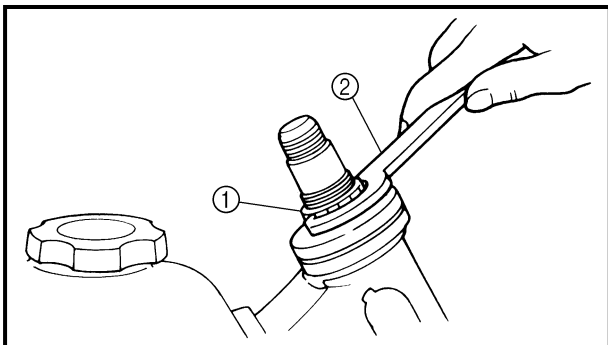

NOTE: _____
Remove the ring nut ① by using the ring nut wrench ②.

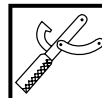

Ring nut wrench:
P/N. YU-33975

⚠ WARNING _____

Support the lower bracket so that it may not fall down.

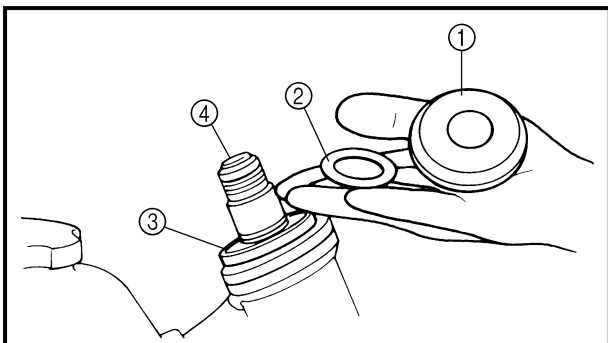

- 12.Remove:
- Washer
 - Cover ①
 - Washer ②
 - Bearing ③ (upper)
 - Steering stem ④

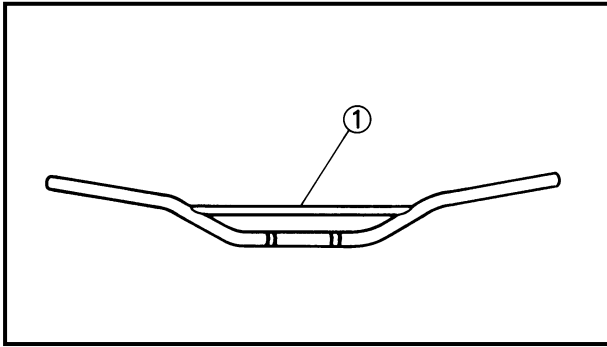

INSPECTION

1. Inspect:

- Handlebar ①
Bends/cracks/damage → Replace.

⚠ WARNING

Do not attempt to straighten a bent handlebar as this may dangerously weaken the handlebar.

Replacement steps:

- Remove the handlebar grip.
- Apply a light coat of an adhesive for rubber on the left new handlebar end.
- Install the handlebar grip.

NOTE:

Wipe off excess adhesive with a clean rag.

⚠ WARNING

Leave the handlebar intact until the adhesive becomes dry enough to make the grip and handlebar stuck securely.

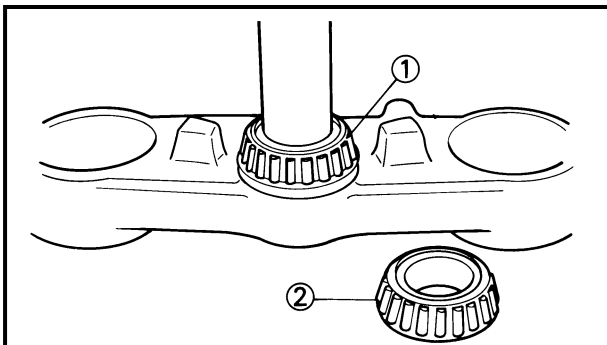

2. Inspect:

- Bearing ① (lower)
- Bearing ② (upper)
- Bearing race
Wear/pitting/damage → Replace as a set.

Replacement steps:

- Remove the bearing races from the slot on the steering head pipe using a long rod ③ and hammer as shown.
- Remove the bearing race on the steering stem using the floor chisel ④ and the hammer as shown.
- Install the new dust seal, bearings and races.

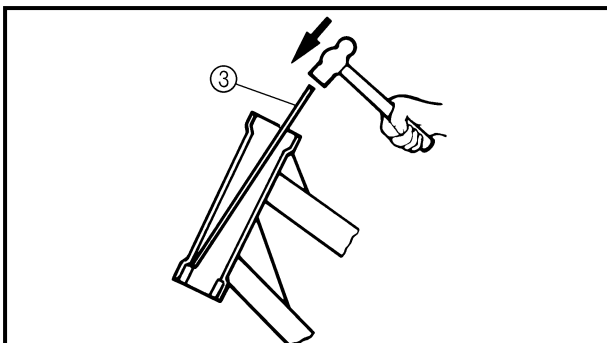

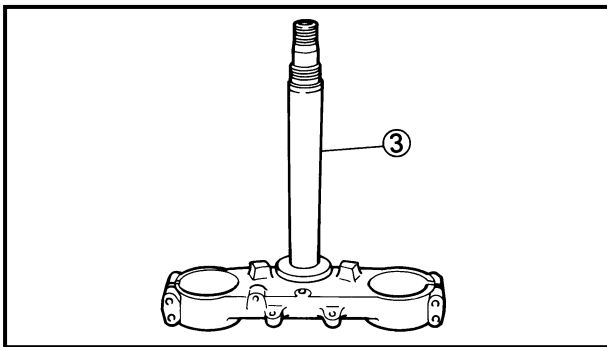
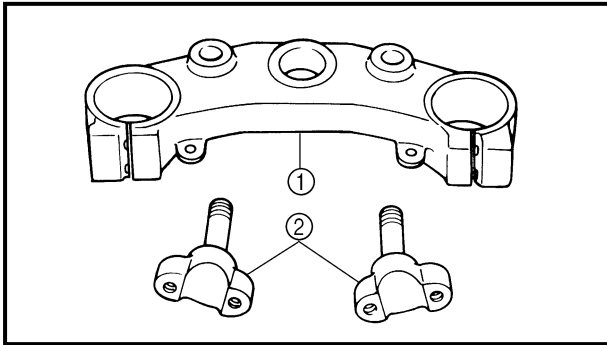
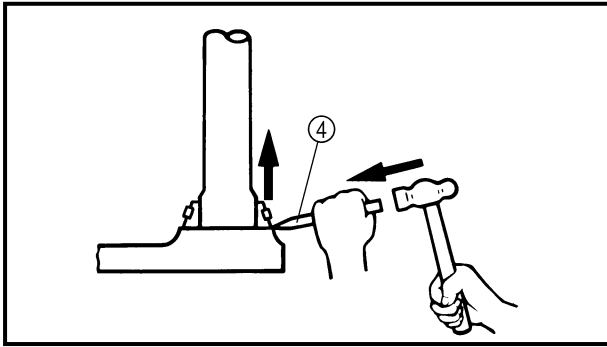

- C**
- Always replace bearings and races as a set.
 - A slant installation of the bearings and the races will damage the frame, so take care to install them horizontally.
 - Do not strike the rollers.

3. Inspect:

- Handlebar crown ①
- Lower bracket ②
Cracks/damage → Replace.
- Steering shaft ③
Bends/damage → Replace the lower bracket assembly.

⚠ WARNING

Do not attempt to straighten a bent steering stem as this may dangerously weaken it.

INSTALLATION

Handlebar

Reverse the "REMOVAL" procedure. Note the following points.

1. Lubricate:
- Handlebar

	Lithium soap base grease
--	---------------------------------

NOTE:

Before installing the throttle grip onto the handlebar, apply a light coat of lithium soap base grease onto the handlebar end.

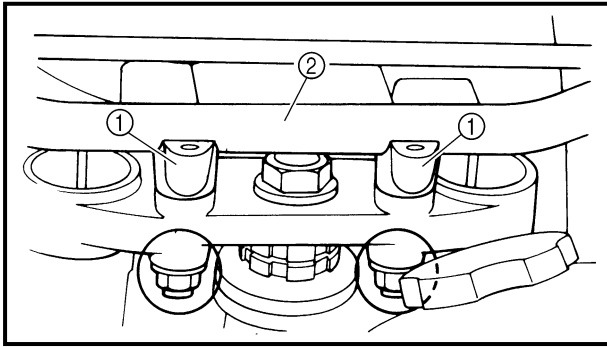

- 2.Install:
- Handlebar holder ① (lower)
 - Clip
 - Handlebar ②



Bolt (handlebar):
23 Nm (2.3 m • kg, 17 ft • lb)

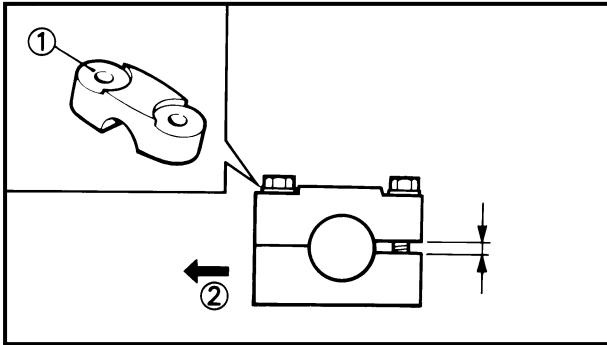

NOTE: _____
The upper handlebar holder should be installed with the punch mark ① facing forward.

② Forward

CA _____

First tighten the bolts on the front side of the handlebar holder, and then tighten the bolts on the rear side.

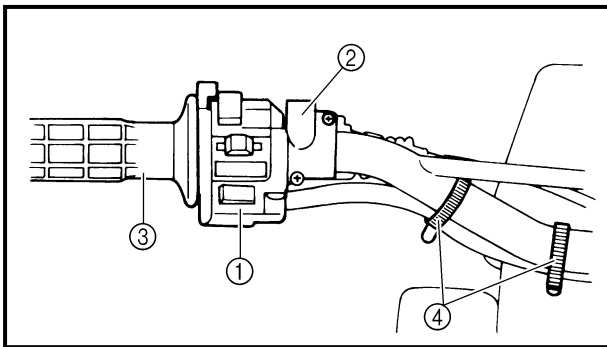

- 3.Install:
- Handlebar switch ① (left)
 - Lever holder ②
 - Grip ③
 - Bands ④

NOTE: _____
Apply a light coat of lithium soap base grease onto the clutch cable end.

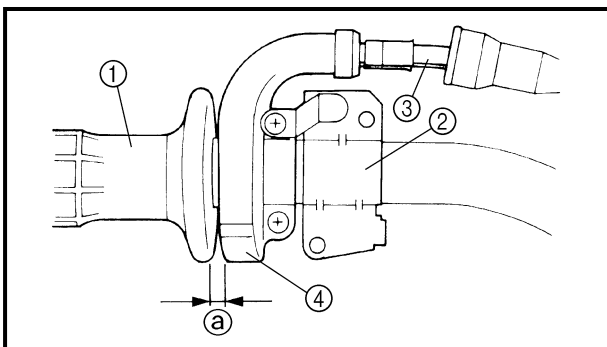

- 4.Install:
- Throttle grip ①
 - Plate ②
 - Throttle cable ③
 - Throttle cable holder ④

⚠ WARNING _____

Provide a clearance of 1 mm (0.04 in) ① between the throttle grip and the throttle cable holder.

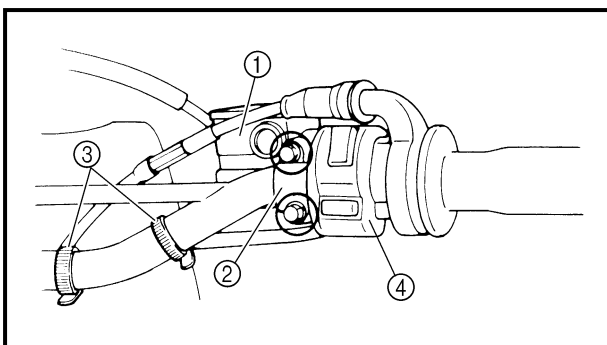

- 5.Install:
- Master cylinder assembly ①
 - Master cylinder bracket ②
 - Bands ③
 - Handlebar switch (right) ④



NOTE:

When installing the handlebar switch (right), make sure its projection fits into the hole.

- Install the master cylinder bracket with the "UP" mark facing upward.
- Tighten first the upper bolt, then the lower bolt.



Bolt (master cylinder bracket):
7 Nm (0.7 m · kg, 5.1 ft · lb)

⚠ WARNING

Proper hose routing is essential to insure safe motorcycle operation. Refer to "CABLE ROUTING" in CHAPTER 2.

6.Adjust:

- Clutch cable free play



Free play:
10 ~ 15 mm (0.4 ~ 0.6 in)
(at the lever end)

Refer to "CLUTCH ADJUSTMENT" in CHAPTER 3.

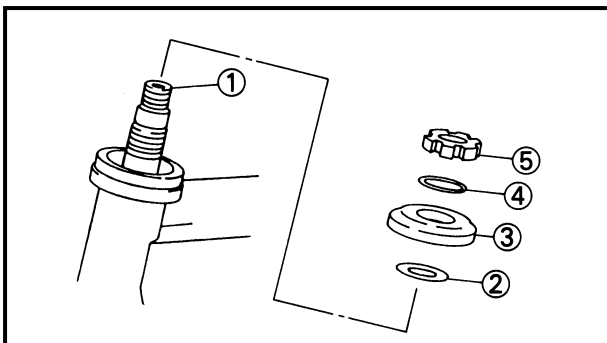
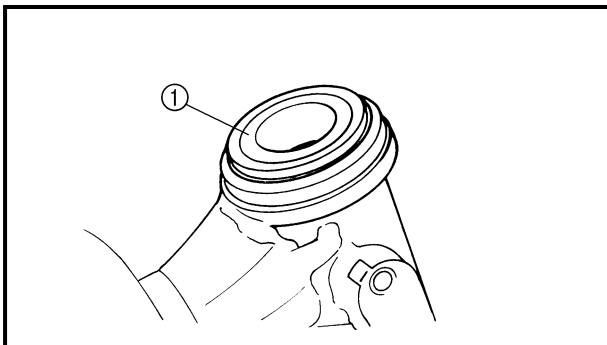

Steering head

Reverse the "REMOVAL" procedure. Note the following points.

1.Lubricate:

- Bearing (upper ① and lower)
- Bearing races



Lithium soap base grease

2.Install:

- Steering shaft ①
- Washer ②
- Cover ③
- Washer ④
- Ring nut ⑤



Hold the steering shaft until it is secured.

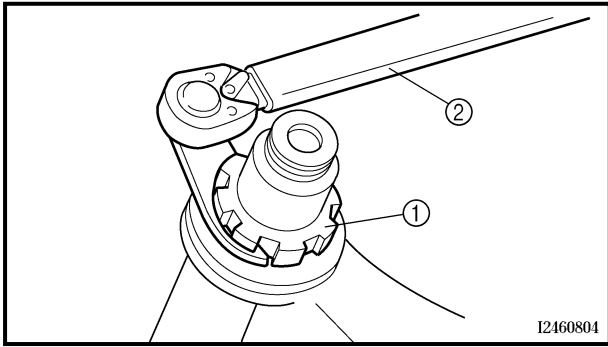

3.Tighten:

- Ring nut ①

Tightening steps:

- Tighten the ring nut using the ring nut wrench ②.



**Ring nut wrench:
P/N. YU-33975**

NOTE:

Set the torque wrench to the ring nut wrench so that they form a right angle.



**Ring nut ① (lower) (initial tightening):
5 Nm (0.5 m • kg, 3.6 ft • lb)**

- Turn the lower bracket to the left and right making sure there is no binding, and then loosen the ring nut one turn.
- Retighten the ring nut using the ring nut wrench.



**Ring nut ① (lower) (final tightening):
38 Nm (3.8 m • kg, 27 ft • lb)**

⚠ WARNING

Avoid over tightening.

NOTE:

Check the steering head by turning the steering from lock to lock, after adjusting the steering head. If the steering is stiff, loosen the ring nut but not to the extent of allowing free play in the bearing. If the steering is loose, repeat the adjustment steps.

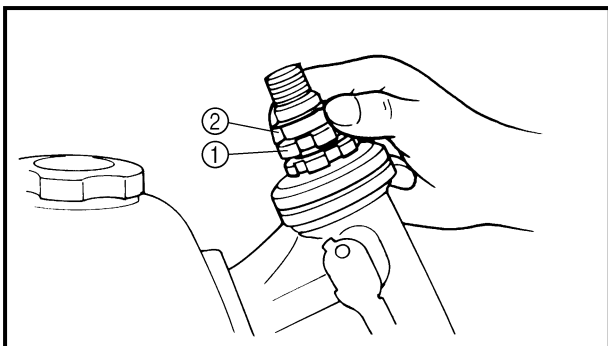

4.Install:

- Rubber washer ②
- Ring nut ①
- Lock washer ②

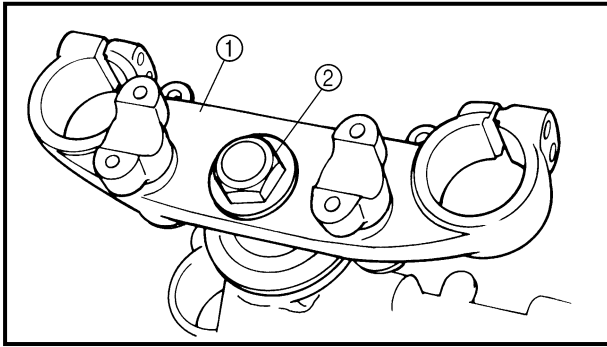

5. Install:

- Handlebar crown ①

NOTE: _____

Temporarily tighten the steering stem nut ②.

6. Install:

- Brake hose holder
- Front flasher assembly

7. Install:

- Front fork
Refer to "FRONT FORK".

NOTE: _____

Temporarily tighten the pinch bolts.

8. Tighten:

- Steering stem nut

	<p>Steering stem nut: 120 Nm (12 m • kg, 85 ft • lb)</p>
--	---

9. Tighten:

- Pinch bolts (front fork)

	<p>Pinch bolt (lower bracket): 30 Nm (3.0 m • kg, 22 ft • lb)</p> <p>Pinch bolt (handlebar crown): 23 Nm (2.3 m • kg, 17 ft • lb)</p>
--	---

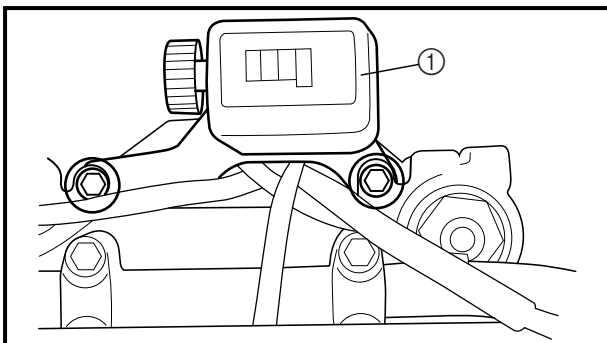

10. Install:

- Speedometer assembly ①

Make sure that the cables and leads are routed properly. Refer to "CABLE ROUTING" in CHAPTER 2.



⚠ WARNING

Proper hose routing is essential to insure safe motorcycle operation. Refer to "CABLE ROUTING" in CHAPTER 2.

11.Connect:

- Speedometer cable

Refer to "CABLE ROUTING" in CHAPTER 2.

12.Install:

- Headlight assembly
- Front cover

13.Install:

- Brake caliper
- Holder (brake hose)

Refer to "FRONT FORK".

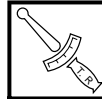

Bolt (brake caliper):
30 Nm (3.0 m • kg, 22 ft • lb)

Bolt (holder):
7 Nm (0.7 m • kg, 5.1 ft • lb)

14.Install:

- Front fender

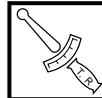

Bolt (front fender):
8 Nm (0.8 m • kg, 5.8 ft • lb)

15.Install:

- Front wheel

Refer to "FRONT WHEEL".

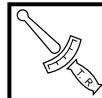

Wheel axle:
58 Nm (5.8 m • kg, 42 ft • lb)

16.Install:

- Handlebar

Refer to "Handlebar".

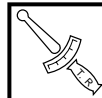

Bolt (handlebar):
23 Nm (2.3 m • kg, 17 ft • lb)

Bolt (master cylinder bracket):
7 Nm (0.7 m • kg, 5.1 ft • lb)



REAR SHOCK ABSORBER AND SWINGARM

① Rear shock absorber

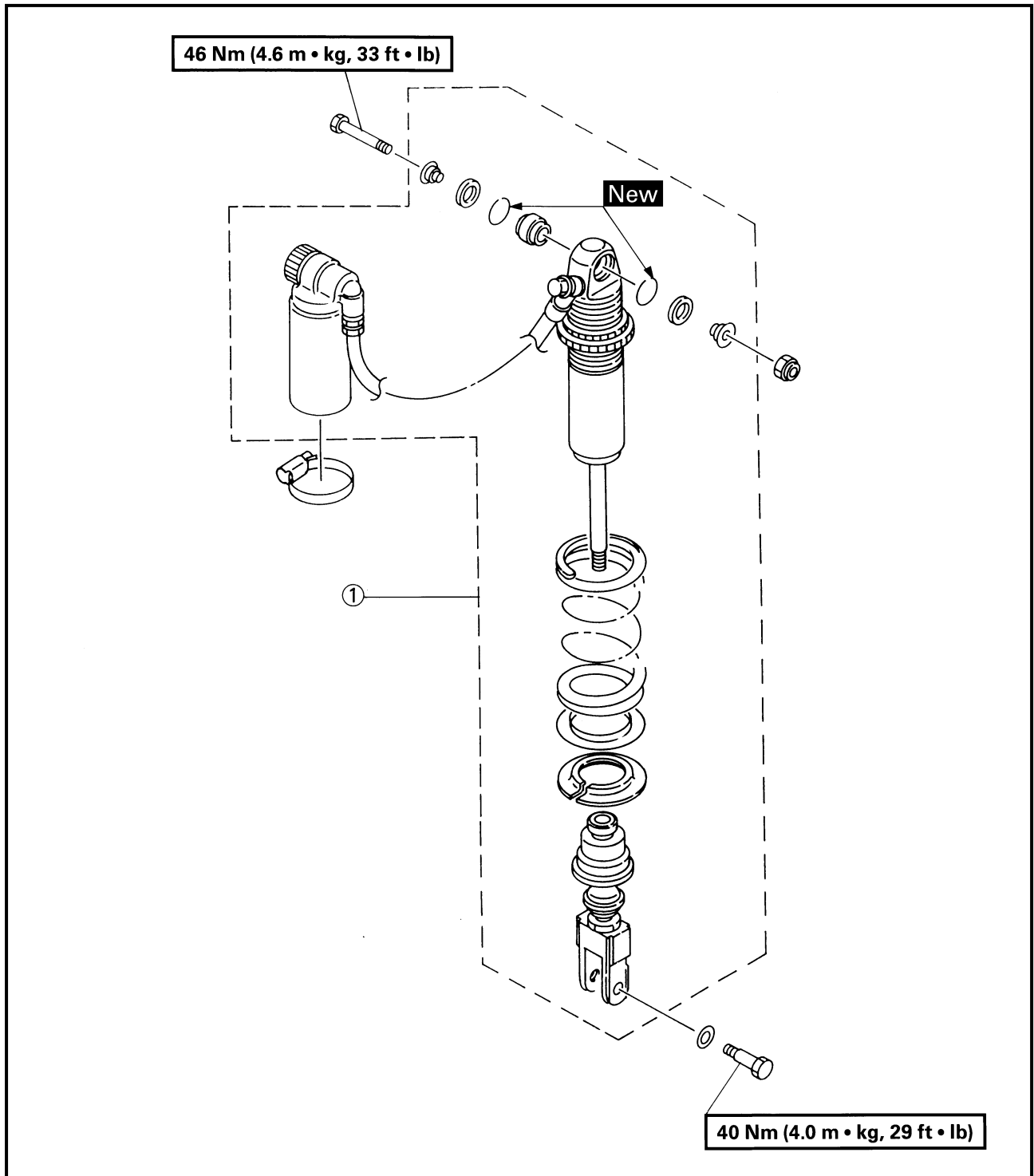

REAR SHOCK ABSORBER AND SWINGARM

CHAS



- | | |
|---------------------------|-------------|
| ① Pivot shaft | ⑫ Collar |
| ② Thrust cover (swingarm) | ⑬ Dust seal |
| ③ Oil seal | ⑭ Circlip |
| ④ Bearing | ⑮ Bearing |
| ⑤ Swingarm | ⑯ Bearing |
| ⑥ Bush | ⑰ Oil seal |
| ⑦ Oil seal | ⑱ Collar |
| ⑧ Bearing | ⑲ Oil seal |
| ⑨ Connecting rod | ⑳ Bearing |
| ⑩ Collar | ㉑ Relay arm |
| ⑪ Oil seal | ㉒ Collar |

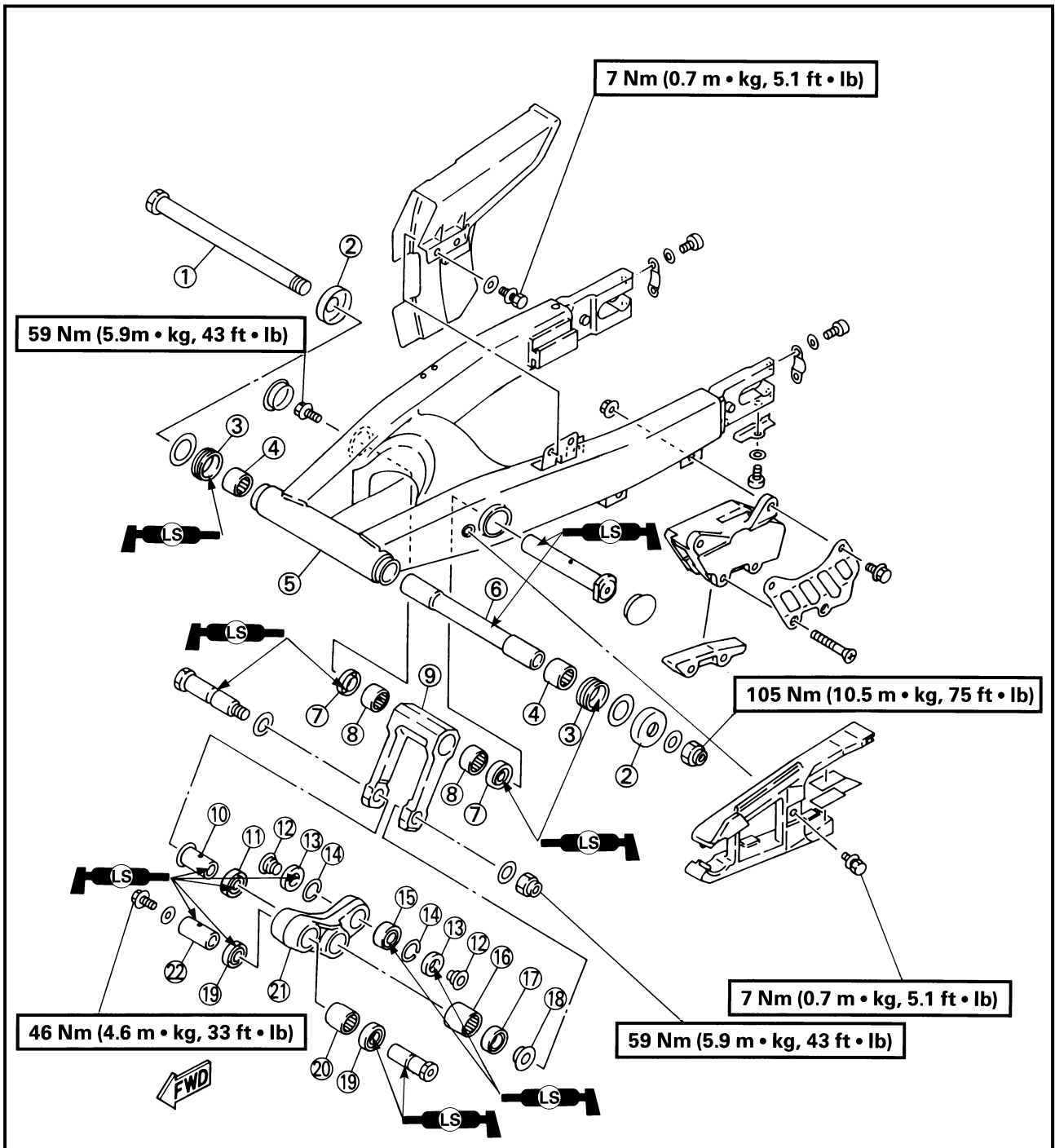



HANDLING NOTES

⚠ WARNING

This shock absorber contains highly pressurized nitrogen gas. Read and understand the following information before handling the shock absorber. The manufacturer cannot be held responsible for property damage or personal injury that may result from improper handling.

- Do not tamper with or attempt to open the cylinder assembly.
- Do not subject shock absorber to an open flame or other high heat source. This may cause the unit to explode due to excessive gas pressure.
- Do not deform or damage the cylinder in any way. Cylinder damage will result in poor damping performance.
- Take care not to scratch the contact surface of the piston rod with the cylinder; or oil could leak out.
- When scrapping the shock absorber, refer to "NOTES ON DISPOSAL".

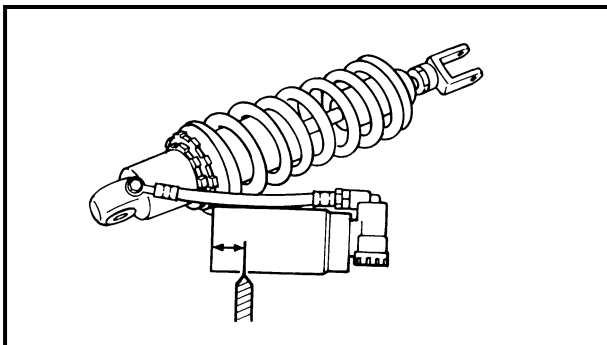

NOTES ON DISPOSAL

Shock absorber disposal steps:

Gas pressure must be released before disposing of the shock absorber assembly. To do so, drill a 2 ~ 3 mm (0.08 ~ 0.12 in) hole through the gas cylinder at a point 15 ~ 20 mm (0.6 ~ 0.8 in) from the end of the gas cylinder case.

⚠ WARNING

Wear eye protection to prevent eye damage from escaping gas and/or metal chips.



REMOVAL

Air filter case

⚠ WARNING

Securely support the motorcycle so there is no danger of it falling over.

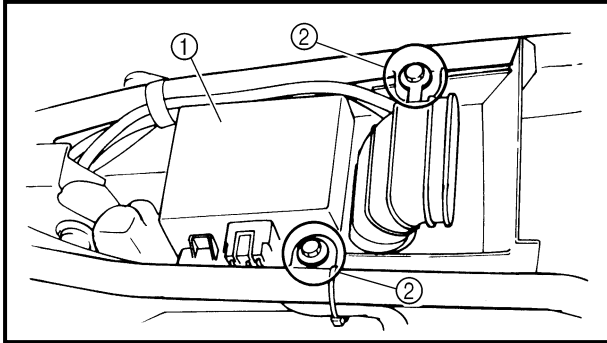

1. Place the motorcycle on a level place.

2. Remove:

- Side covers
- Seat
- Fuel tank

Refer to "SEAT, FUEL TANK AND COVERS" in CHAPTER 3.

3. Elevate the rear wheel by placing a suitable stand under the frame and engine.

4. Disconnect:

- CDI unit ①
- Bolts ②

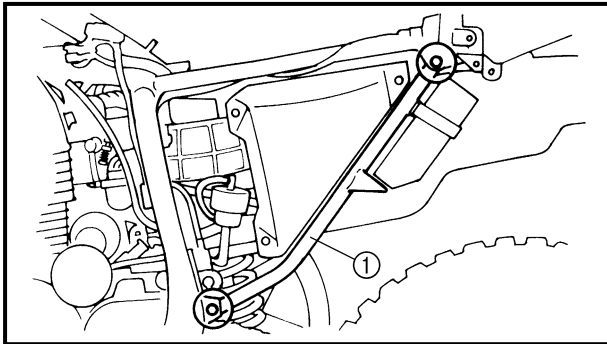

5. Remove:

- Rear frame 2 ①

6. Disconnect:

- Breather hose 1
- Breather hose 2

Refer to "CRANKCASE BREATHER HOSE INSPECTION" in CHAPTER 3.

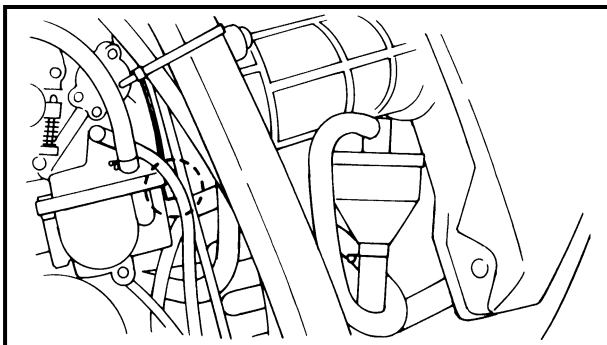

7. Loosen:

- Screw (carburetor joint clamp)

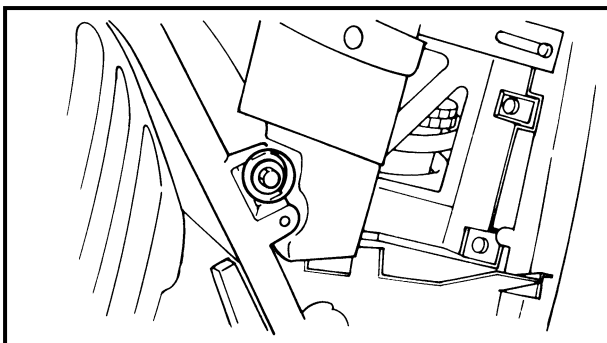

8. Remove:

- Bolts

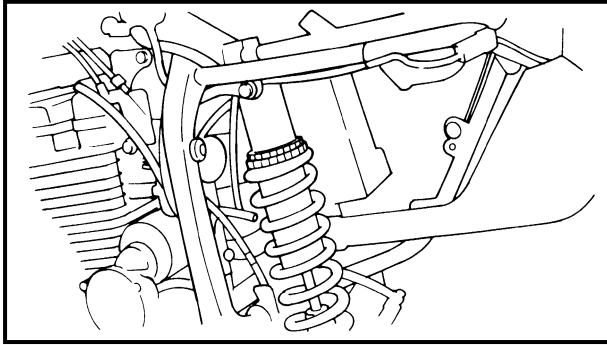

- 9.Remove:
- Air filter case assembly

Rear shock absorber

⚠ WARNING

Securely support the motorcycle so there is no danger of it falling over.

- 1.Place the motorcycle on a level place.
- 2.Remove:
 - Side covers
 - Seat
 - Fuel tank
 Refer to "SEAT, FUEL TANK AND COVERS" in CHAPTER 3.
- 3.Elevate the rear wheel by placing a suitable stand under the frame and engine.

- 4.Remove:
 - Air filter case assembly
 Refer to "Air filter case".
- 5.Disconnect:
 - Carburetor assembly
 Refer to "CARBURETOR" in CHAPTER 5.

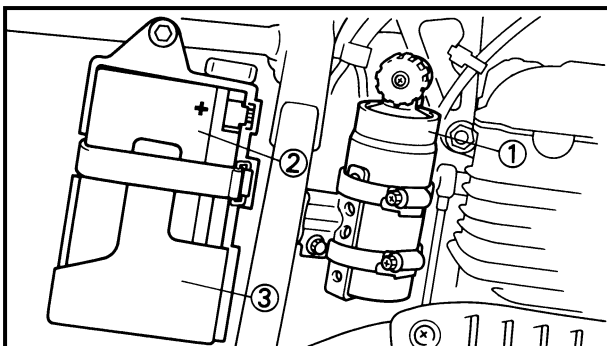

- 6.Remove:
 - Gas cylinder ① (shock absorber assembly)
 - Battery ②
 - Battery case ③

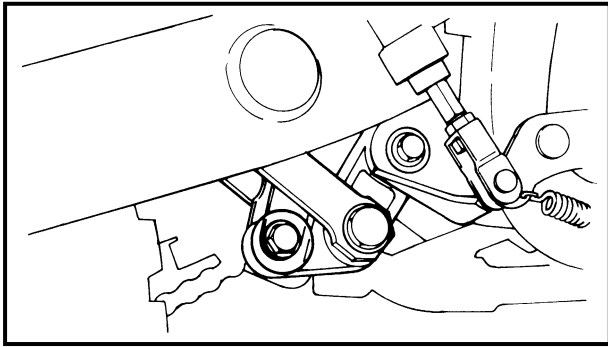

- 7.Remove:
- Rear shock absorber bolt (lower)

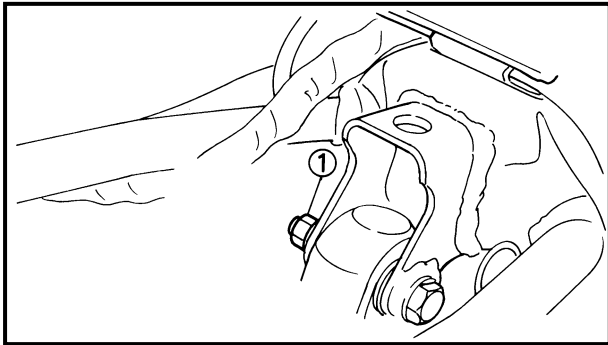

- 8.Remove:
- Rear shock absorber nut ① (upper)

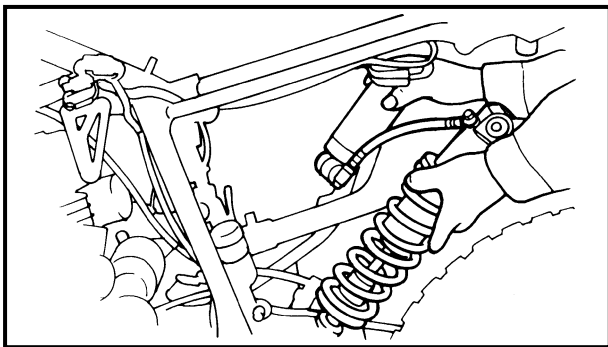

- 9.Remove:
- Rear shock absorber

Swingarm

⚠ WARNING

Securely support the motorcycle so there is no danger of it falling over.

- 1.Place the motorcycle on a level place.
- 2.Elevate the rear wheel by placing a suitable stand under the frame and engine.
- 3.Remove:
 - Rear shock absorber
Refer to "Rear shock absorber".
- 4.Remove:
 - Rear wheel
Refer to "REAR WHEEL".

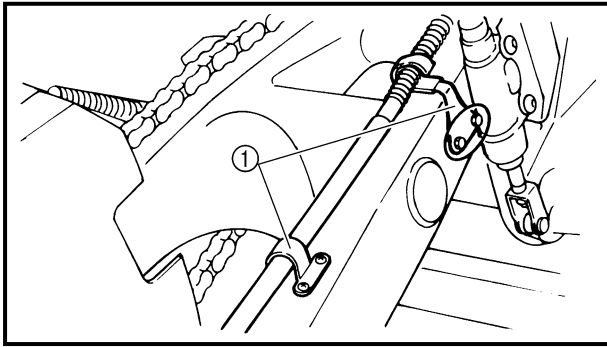

5.Remove:

- Brake hose holders ①
- Rear brake caliper

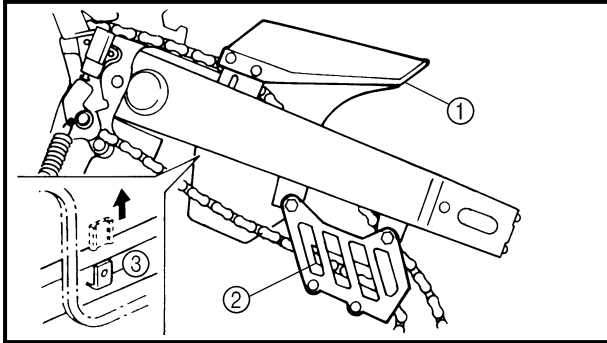

6.Remove:

- Chain case ①
- Chain guide ②

NOTE:

When removing the chain case, lift up and remove the chain case from the swingarm L-shaped part ③ on the back.

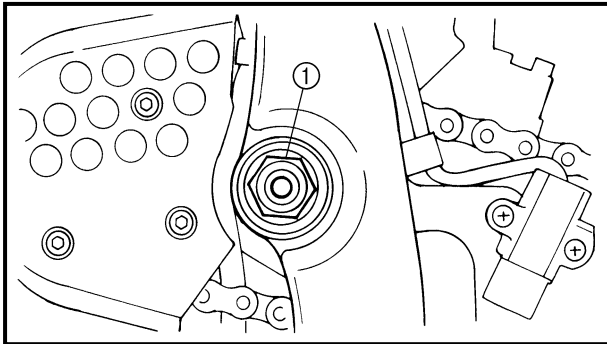

7.Check:

- Swingarm free play

Inspection steps:

- Check the tightening torque of the pivot shaft (swingarm) securing nut ①.



Nut ① (pivot shaft):
105 Nm (10.5 m · kg, 75 ft · lb)

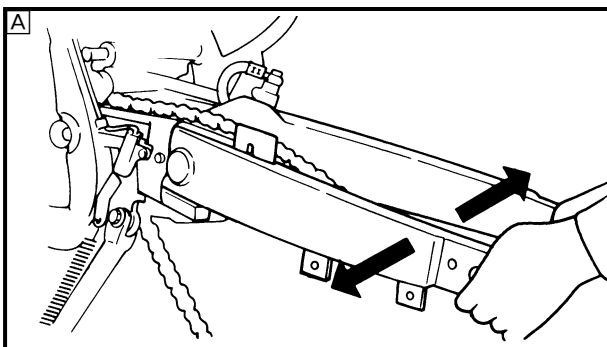

- Check the swingarm side play [A] by moving it from side to side.

If side play is noticeable, check the inner collar, bearing, washer and thrust cover.



Side play (at end of swingarm):
Limit: 1.0 mm (0.04 in)

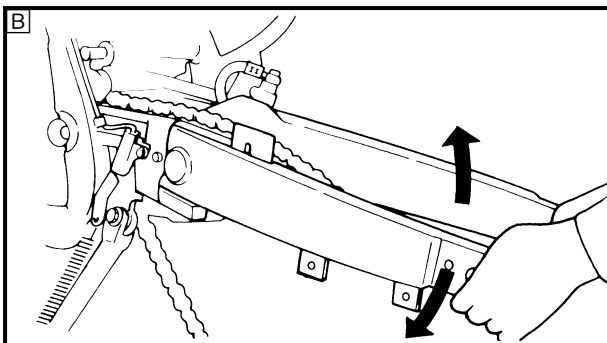

- Check the swingarm vertical movement [B] by moving it up and down.

If vertical movement is tight or if there is binding, check the inner collar, bearing, washer and thrust cover.

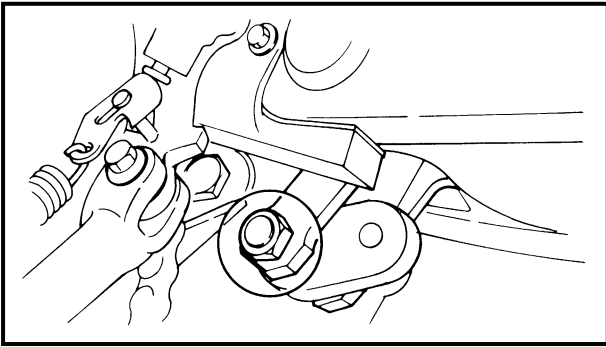

- 8.Remove:
- Bolt (relay arm-connecting rod)
 - Nut

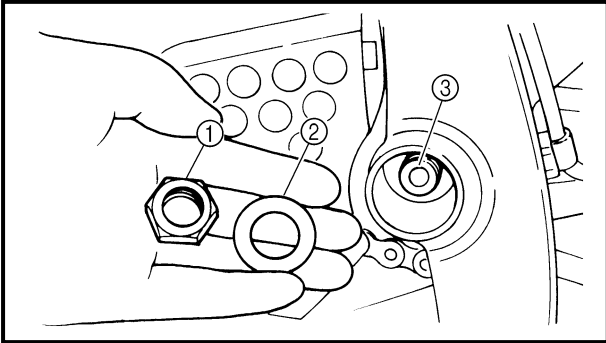

- 9.Remove:
- Nut ① (pivot shaft)
 - Washer ②
 - Pivot shaft ③
 - Swingarm

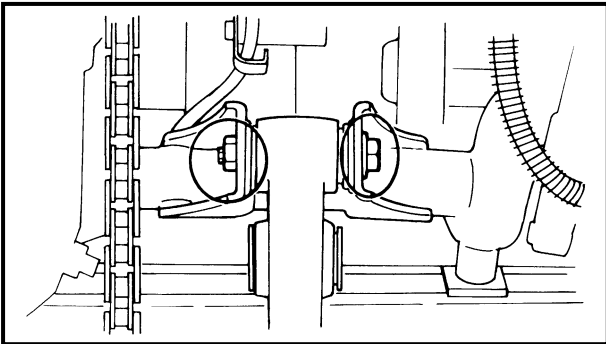

- 10.Remove:
- Relay arm

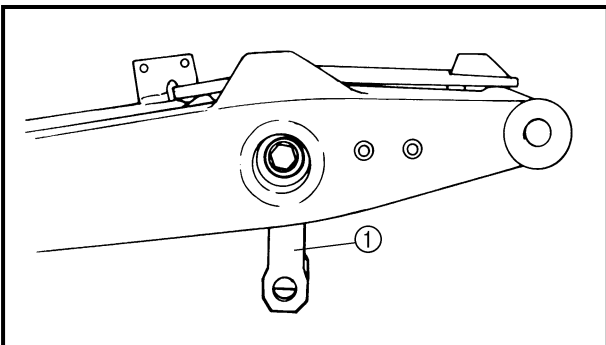

- 11.Remove:
- Caps
 - Connecting arm ①

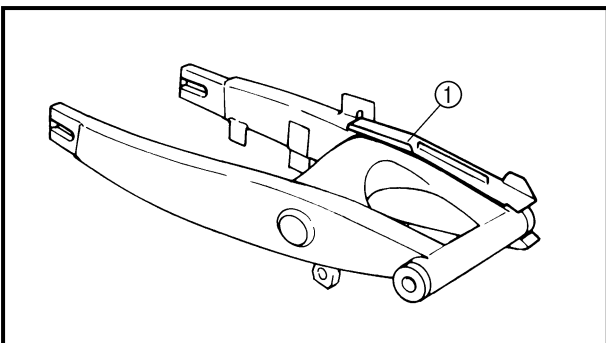

- 12.Remove:
- Chain protector ①



INSPECTION

1. Inspect:

- Rear shock absorber
Oil leaks/damage → Replace the rear shock absorber.
- Gas cylinder
Oil leaks/damage → Replace the rear shock absorber.

⚠ WARNING

Do not disassemble the shock absorber, because of the highly pressurized nitrogen gas in it.

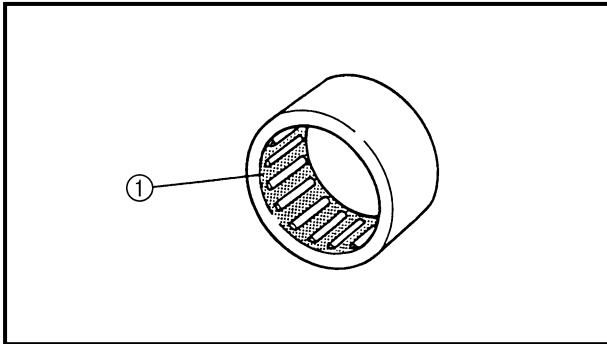

2. Inspect:

- Bearing
Pitting/noise/damage → Replace.
Loss of solid lubrication ① → Replace.

NOTE:

Polylube bearings*, with solid lubrication, have been adopted with the intent to make the needle bearings, used in this model, maintenance free. With polylube bearings, no grease nipple and regular lubrication is necessary. However, grease should be applied to all oil seals and collars when removed or installed.

*Polylube bearing

Grease and an ultra-high molecular weight polyethylene are the lubricating elements which are used. These two elements become solid after heat treatment, where they are sealed into the bearing race and perform as a solid lubricant to reduce friction when necessary.



Features

- Water seepage is no longer a problem since the polylube is solid. If water seeps into the bearing, it will emulsify and will not flow out.
- Lubrication can continuously be supplied to the contact points when heat is generated by the friction caused by the centrifugal forces, since the lubricant is solid and always remains inside the bearing.

C

- **Be careful not to damage the solid lubrication of the bearing when removing, inspecting, or installing the bearing.**
- **If the bearing is damaged, replace it with a new one.**

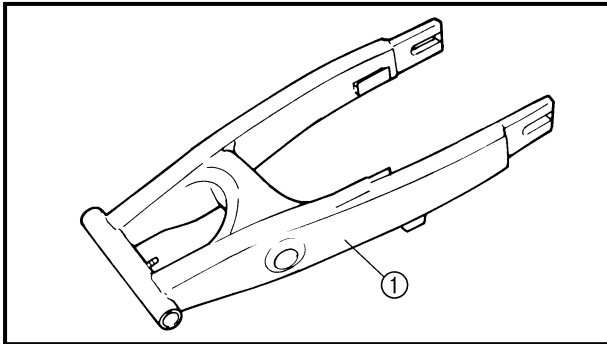

3. Inspect:

- Swingarm ①
Bends/cracks/damage → Replace.

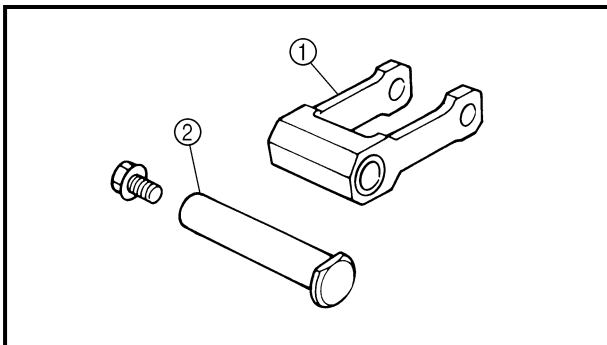

4. Inspect:

- Connecting arm ①
Bends/cracks/damage → Replace.
- Collars ②
Wear/damage → Replace.

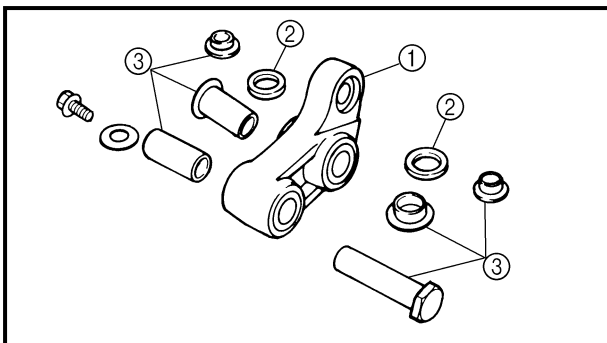

5. Inspect:

- Relay arm ①
Bends/cracks/damage → Replace.
- Oil seals ②
Wear/damage → Replace.
- Collars ③
Wear/damage → Replace.

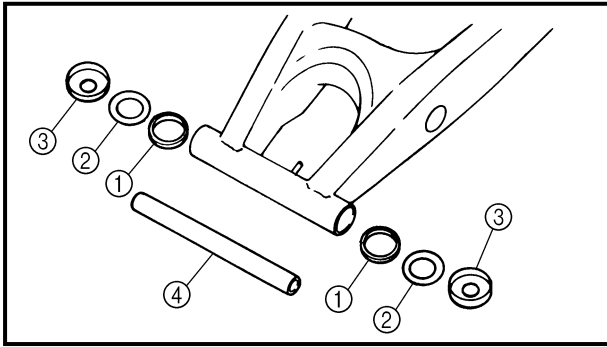

6. Inspect:

- Oil seal ①
Wear/damage → Replace.
- Washer ②
- Thrust cover ③
- Bush ④
Scratches/damage → Replace.

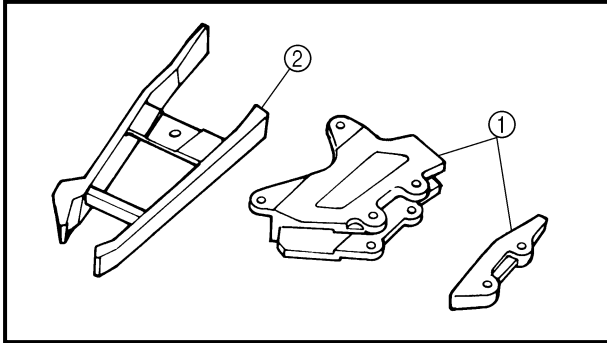

7. Inspect:

- Chain guide ①
- Chain protector ②
Cracks/damage → Replace.

INSTALLATION

Rear shock absorber

Reverse the "REMOVAL" procedure.

Note the following points.

1. Lubricate:

- Collars (inner surface)

	Molybdenum disulfide grease
--	------------------------------------

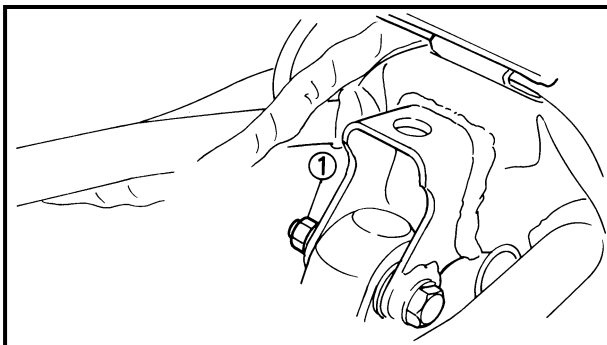

2. Install:

- Rear shock absorber

3. Tighten:

- Nut ① (upper side)

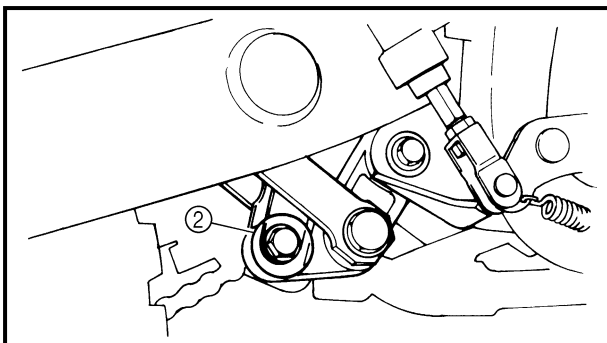

4. Tighten:

- Bolt ② (lower side)

	Nut ① (upper side): 46 Nm (4.6 m · kg, 33 ft · lb)
	Bolt ② (lower side): 40 Nm (4.0 m · kg, 29 ft · lb)

5. Install:

- Gas cylinder
- Carburetor assembly



6.Install:

- Air filter case
Refer to "REAR SHOCK ABSORBER AND SWINGARM".

7.Install:

- CDI unit
- Rear frame 2

Swingarm

Reverse "REMOVAL" procedure.

Note the following points.

1.Lubricate:

- Oil seal
- Bushing
- Thrust cover (inside)
- Collar
- Pivot shaft
- Bolt (relay arm-swingarm)
- Bolt (connecting arm-relay arm)
- Bolt (connecting arm-frame)

	Molybdenum disulfide grease
--	------------------------------------

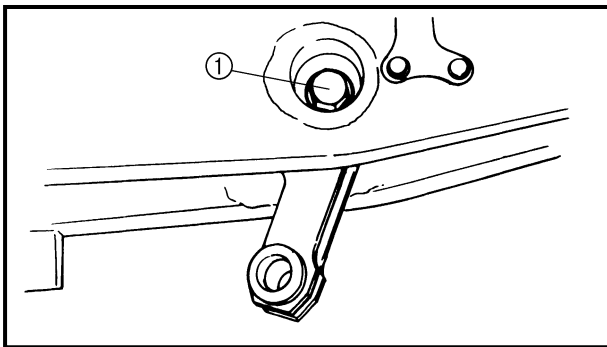

2.Tighten:

- Nut ① (swingarm-connecting arm)

	Nut ① (swingarm-connecting arm): 59 Nm (5.9 m • kg, 43 ft • lb)
--	--

3.Install:

- Rubber caps
- Chain protector

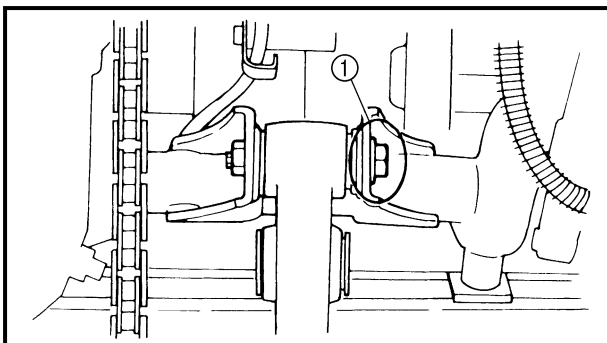

4.Install:

- Bolt ① (frame-relay arm)

	Bolt ① (relay arm): 46 Nm (4.6 m • kg, 33 ft • lb)
--	---

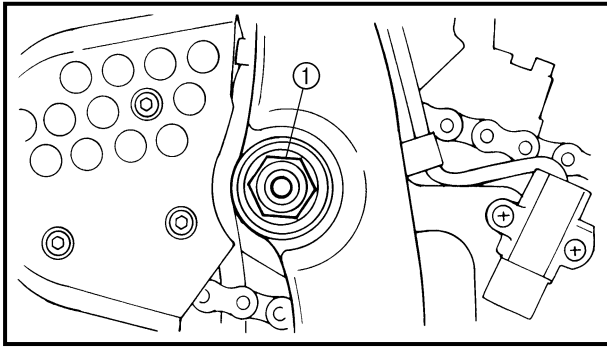

- 5.Tighten:
- Swingarm
 - Nut ① (pivot shaft)

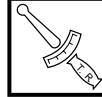

Nut ① (pivot shaft):
105 Nm (10.5 m • kg, 75 ft • lb)

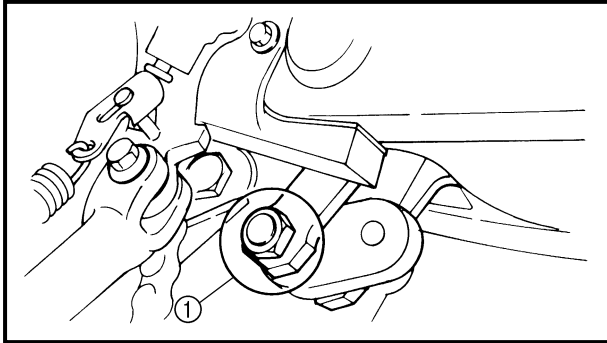

- 6.Install:
- Nut ① (connecting arm-relay arm)

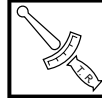

Nut ① (connecting arm-relay arm):
59 Nm (5.9 m • kg, 43 ft • lb)

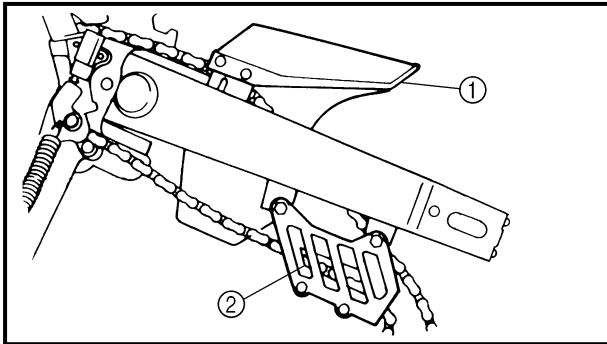

- 7.Tighten:
- Bolt ① (chain case)
 - Bolt ② (chain guide)

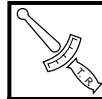

Bolt ① (chain case):
7 Nm (0.7 m • kg, 5.1 ft • lb)
Bolt ② (chain guide):
7 Nm (0.7 m • kg, 5.1 ft • lb)

- 8.Install:
- Rear shock absorber
Refer to "REAR SHOCK ABSORBER".

- 9.Install:
- Rear wheel
Refer to "REAR WHEEL".

- 10.Adjust:
- Drive chain slack



Drive chain slack:
35 ~ 50 mm (1.38 ~ 1.97 in)

Refer to "DRIVE CHAIN SLACK ADJUSTMENT" in CHAPTER 3.



11. Tighten:

- Axle nut



Axle nut:
105 Nm (10.5 m · kg, 75 ft · lb)

Refer to "REAR WHEEL".

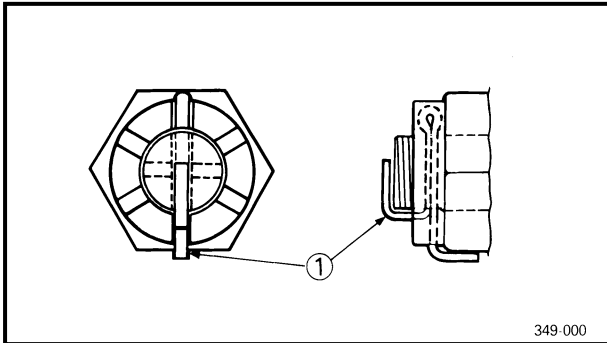

12. Install:

- Cotter pin ①

NOTE: _____
Bend the ends of the cotter pin as illustrated.

⚠ WARNING _____

Always use a new cotter pin.

13. Install:

- Fuel tank
- Seat
- Side covers



Bolt
(fuel tank, seat and side covers):
7 Nm (0.7 m · kg, 5.1 ft · lb)



DRIVE CHAIN AND SPROCKETS

- ① Driven sprocket
- ② Chain joint
- ③ Drive chain
- ④ Washer
- ⑤ Drive sprocket

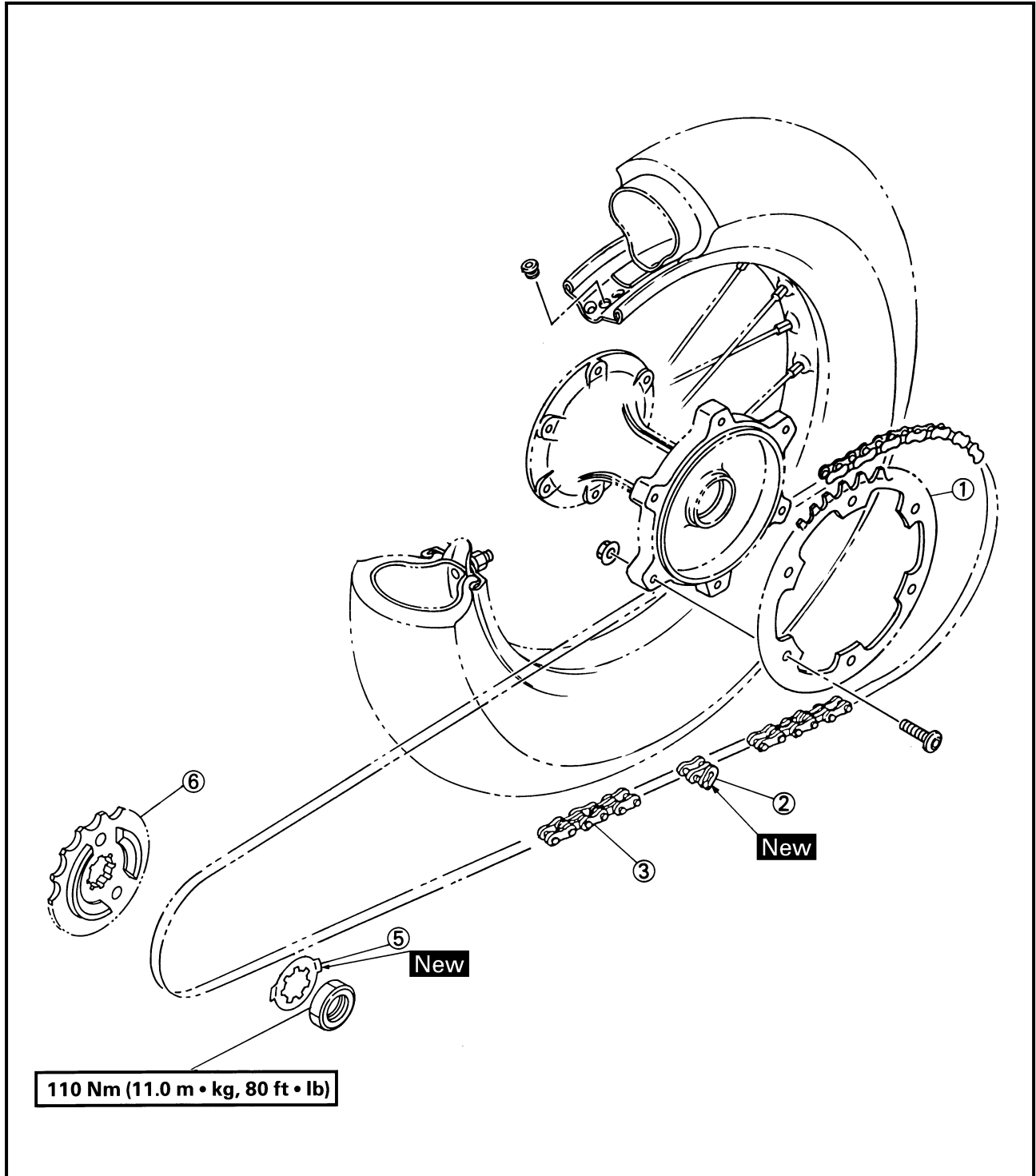



NOTE:

Before removing the drive chain and sprockets, drive chain slack and 10-link length of drive chain should be measured.

REMOVAL

1. Elevate the rear wheel by placing a suitable stand under the frame and engine.

⚠ WARNING

Securely support the motorcycle so there is no danger of it falling over.

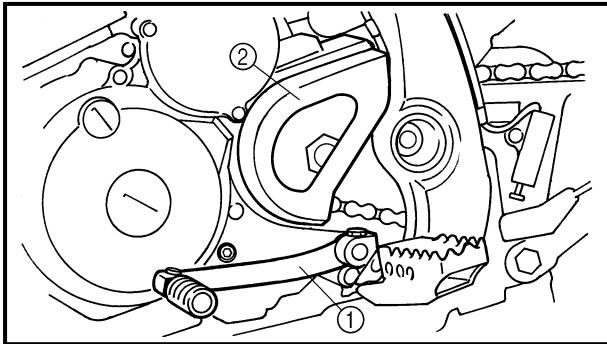

2. Remove:

- Shift pedal ①
- Crankcase cover 2 ②

3. Remove:

- Drive sprocket
 - Drive chain
- Refer to "ENGINE REMOVAL" in CHAPTER 4.

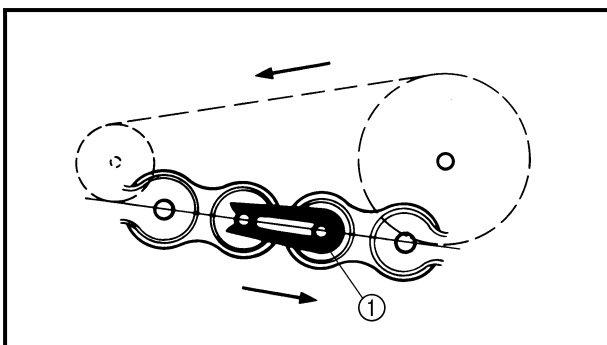

4. Remove:

- Chain joint clip ①

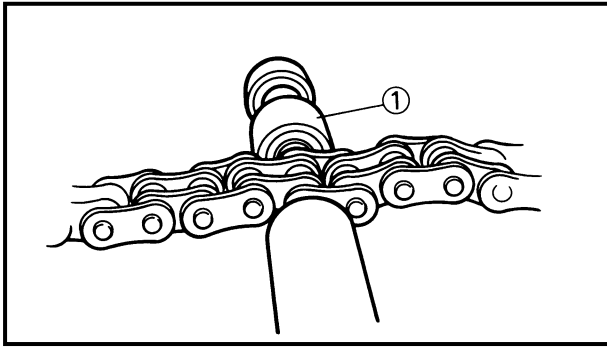

5.Remove:

- Chain joint
- Use the drive chain cutter tool ①.



Drive chain cutter:
P/N. 90890-01286

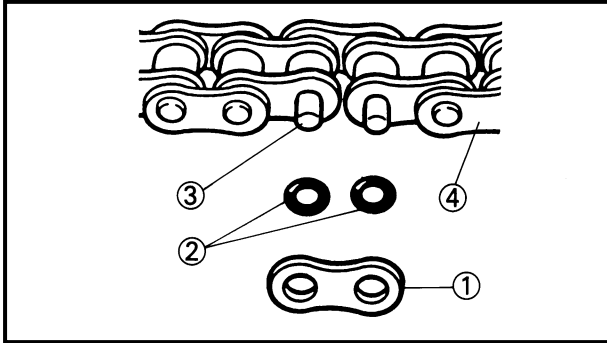

6.Remove:

- Link plate ①
- O-ring ②
- Pin ③
- Drive chain ④

7.Remove:

- Rear wheel
- Refer to "REAR WHEEL".

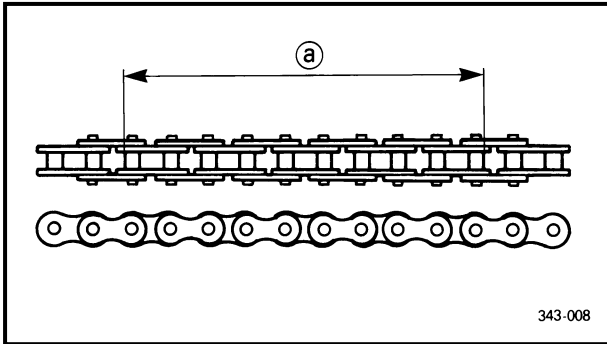

INSPECTION

1.Measure:

- 10-link length @ (drive chain)
- Use @ vernier caliper gauge.
- Out of specification → Replace the drive chain.



10-link length limit:
150.1 mm (5.90 in)

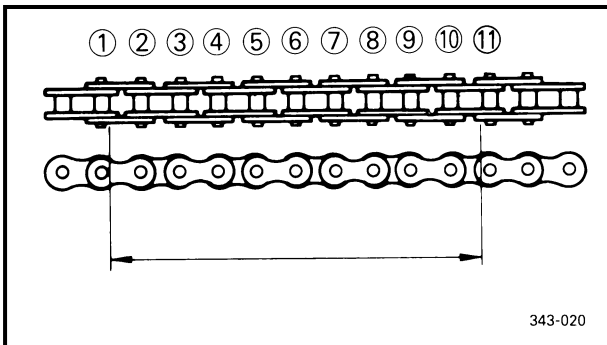

NOTE:

- For measurement, increase the chain tension with you finger.
- 10-link length is a measurement between the inside edges of the ① and ⑾ rollers as shown.
- Two or three different 10-link lengths should be measured.

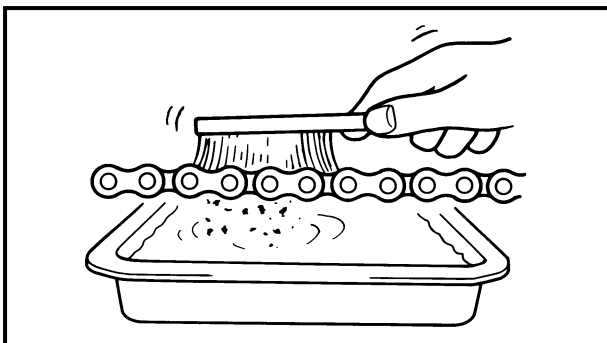

2.Clean:

- Drive chain
- Place it in kerosene, and brush off as much dirt as possible. Then, remove the chain from the kerosene and dry it off.

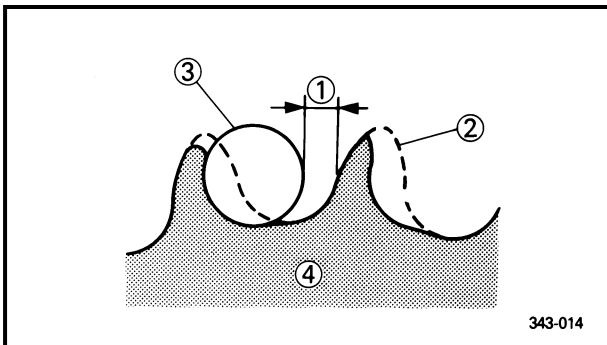
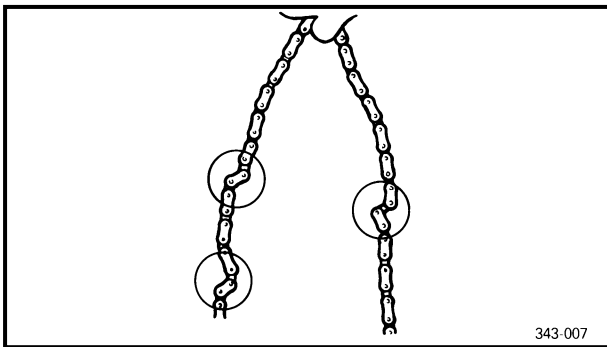
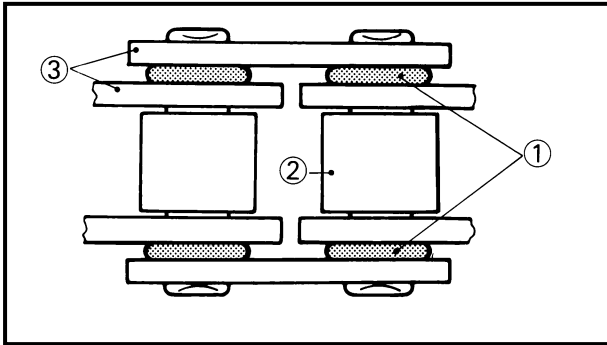
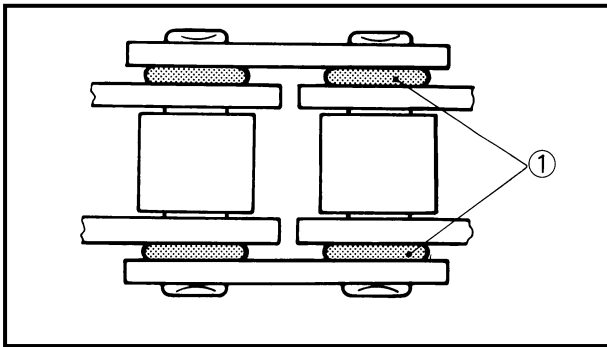

C

This motorcycle has a drive chain with small rubber O-rings ① between the chain plates. Steam cleaning, high-pressure washers, and certain solvents can damage these O-rings. Use only kerosene to clean the drive chain.

3. Inspect:

- O-ring ① (drive chain)
Damage → Replace the drive chain.
- Rollers ②
- Chain joint ③
Damage/wear → Replace the drive chain.

Replace the whole drive chain when one O-ring falls off.

Replace the drive chain, the drive sprocket and the driven sprocket as a set.

4. Inspect:

- Drive chain stiffness
Stiff → Clean and lubricate or replace.

5. Inspect:

- Drive sprocket
- Driven sprocket
More than 1/4 tooth ① wear → Replace the sprocket.
Bent teeth → Replace the sprocket.
- ② Correct
- ③ Roller
- ④ Sprocket

INSTALLATION

Reverse the "REMOVAL" procedure. Note the following points.

1. Lubricate:

- Drive chain
- Chain joint (new)

Drive chain lubricant:
SAE 30 ~ 50W motor oil or chain lubricants suitable for "O-ring" chains.



2.Install:

- Rear wheel
Refer to "REAR WHEEL".

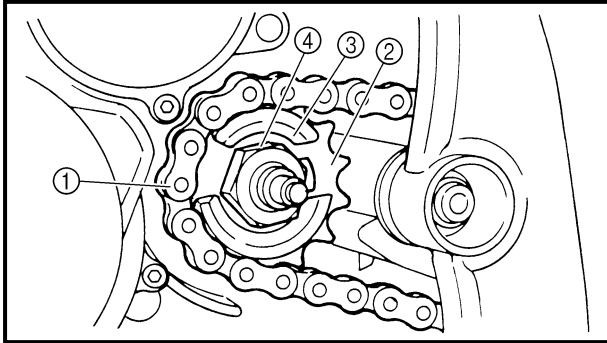

3.Install:

- Drive chain ①
- Drive sprocket ②
- Washer ③
- Nut ④



Nut (drive sprocket):
110 Nm (11.0 m · kg, 80 ft · lb)

NOTE:

Tighten the nut (drive sprocket) while applying the rear brake.

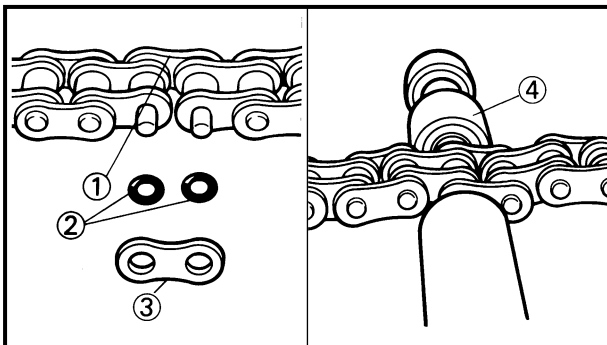

4.Install:

- Chain joint ①
- O-ring ②
- Link plate ③
- Use the drive chain cutter tool ④.



Drive chain cutter:
P/N. YM-33858

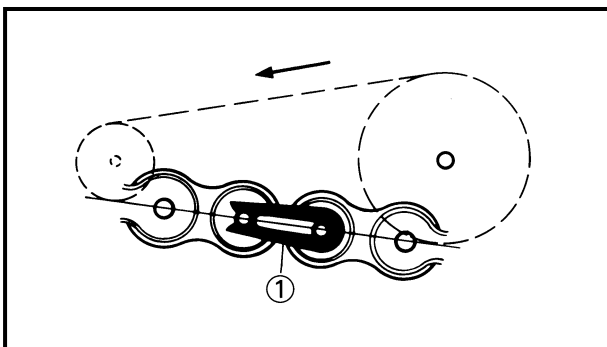

5.Install:

- Chain joint clip ①

CA

Be sure to install the chain joint clip to the direction as shown.

6.Adjust:

- Drive chain slack
Refer to "DRIVE CHAIN SLACK ADJUSTMENT" in CHAPTER 3.



Drive chain slack:
35 ~ 50 mm (1.38 ~ 1.97 in)



C

Too little chain slack will overload the engine and other vital parts; keep the slack within the specified limits.

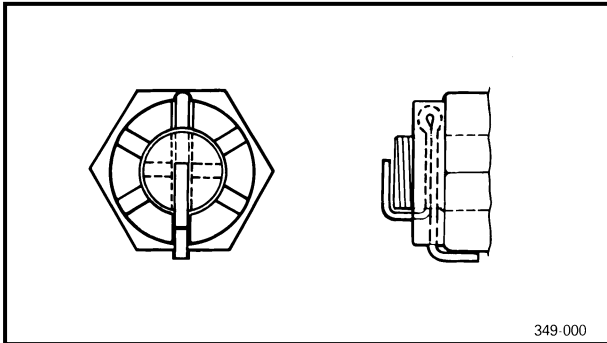

7. Tighten:

- Axle nut
- Bolt (drive sprocket)



Axle nut:
105 Nm (10.5 m • kg, 75 ft • lb)

Refer to "REAR WHEEL".

8. Install:

- Cotter pin

NOTE:

Bend the ends of the cotter pin as illustrated.

⚠ WARNING

Always use a new cotter pin.

9. Install:

- Crankcase cover 2 (drive sprocket)
- Shift pedal

Refer to "ENGINE ASSEMBLY AND ADJUSTMENT" in CHAPTER 4.



Bolt (crankcase cover 2):
10 Nm (1.0 m • kg, 7.2 ft • lb)

Bolt (shift pedal):
10 Nm (1.0 m • kg, 7.2 ft • lb)

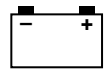

ELECTRICAL

TTR250L(C) CIRCUIT DIAGRAM

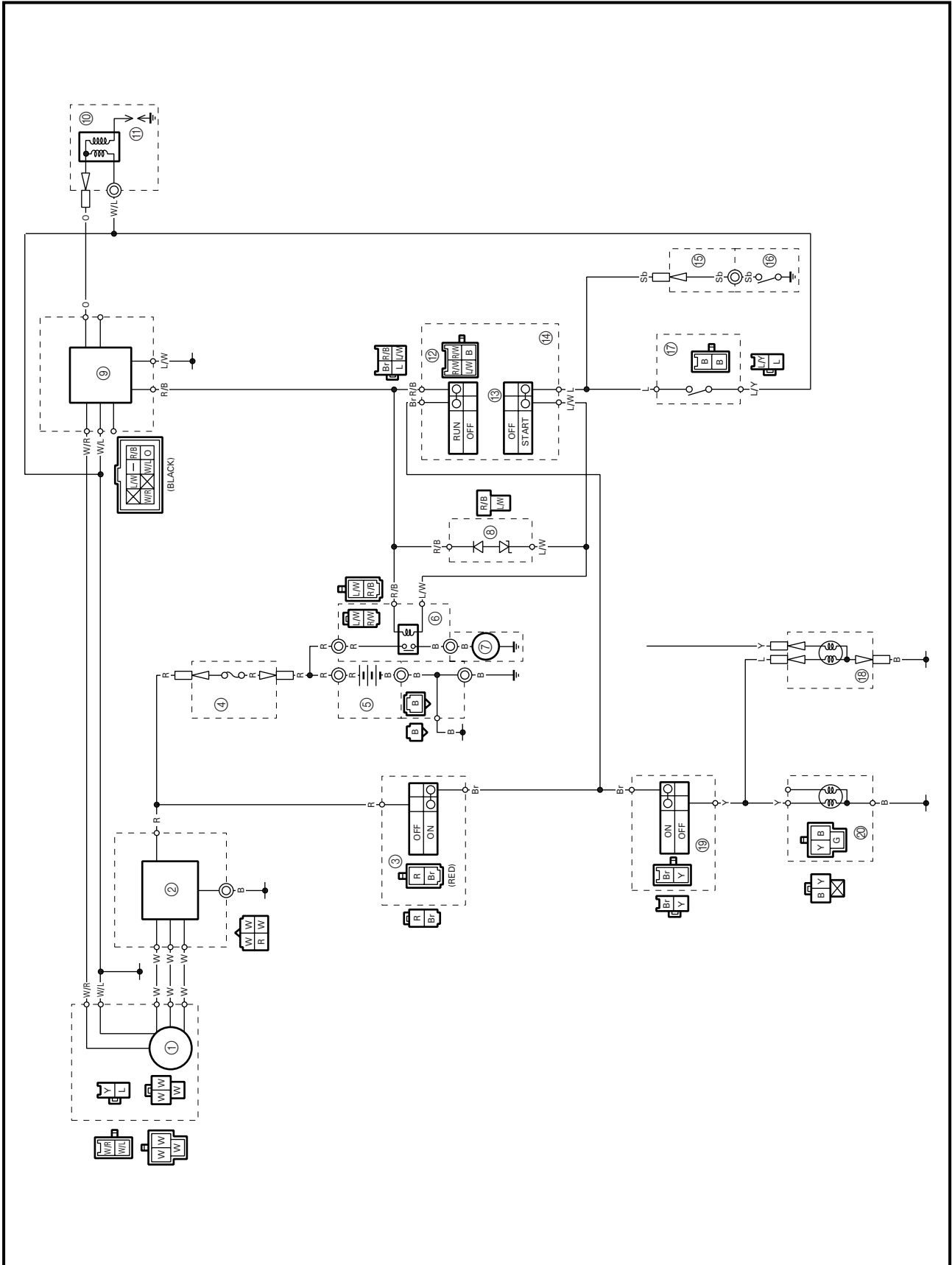

7

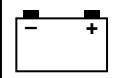

- ① AC magneto
- ② Rectifier/regulator
- ③ Main switch
- ④ Fuse (main)
- ⑤ Battery
- ⑥ Starter relay
- ⑦ Starter motor
- ⑧ Diode
- ⑨ CDI unit
- ⑩ Ignition coil
- ⑪ Spark plug
- ⑫ "ENGINE STOP" switch
- ⑬ "START" switch
- ⑭ Handlebar switch (right)
- ⑮ Wire sub lead
- ⑯ Neutral switch
- ⑰ Clutch switch
- ⑱ Tail light
- ⑲ "LIGHTS" switch
- ⑳ Headlight

NOTE:

- The "START" switch is closed while the button (switch) is pushed.
- The clutch switch is closed while the clutch lever is pulled.
- The neutral switch is closed while the transmission is in neutral.

COLOR CODE

B	Black	R	Red	L/Y	Blue/Yellow
Br	Brown	Sb	Sky blue	R/B	Red/Black
G	Green	W	White	R/W	Red/White
L	Blue	Y	Yellow	W/L	White/Blue
O	Orange	L/W	Blue/White	W/R	White/Red

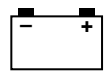

ELECTRICAL COMPONENTS

- ① Wireharness
- ② Rectifier/regulator
- ③ CDI unit
- ④ Battery
- ⑤ Fuse
- ⑥ Fuse holder assembly
- ⑦ Ignition coil
- ⑧ Plug cap
- ⑨ Main switch assembly

BATTERY:
SPECIFIC GRAVITY: 1.320

IGNITION COIL:
PRIMARY COIL RESISTANCE:
 0.36 ~ 0.48 Ω at 20 °C (68 °F)
SECONDARY COIL RESISTANCE:
 5.4 ~ 7.4 k Ω at 20 °C (68 °F)

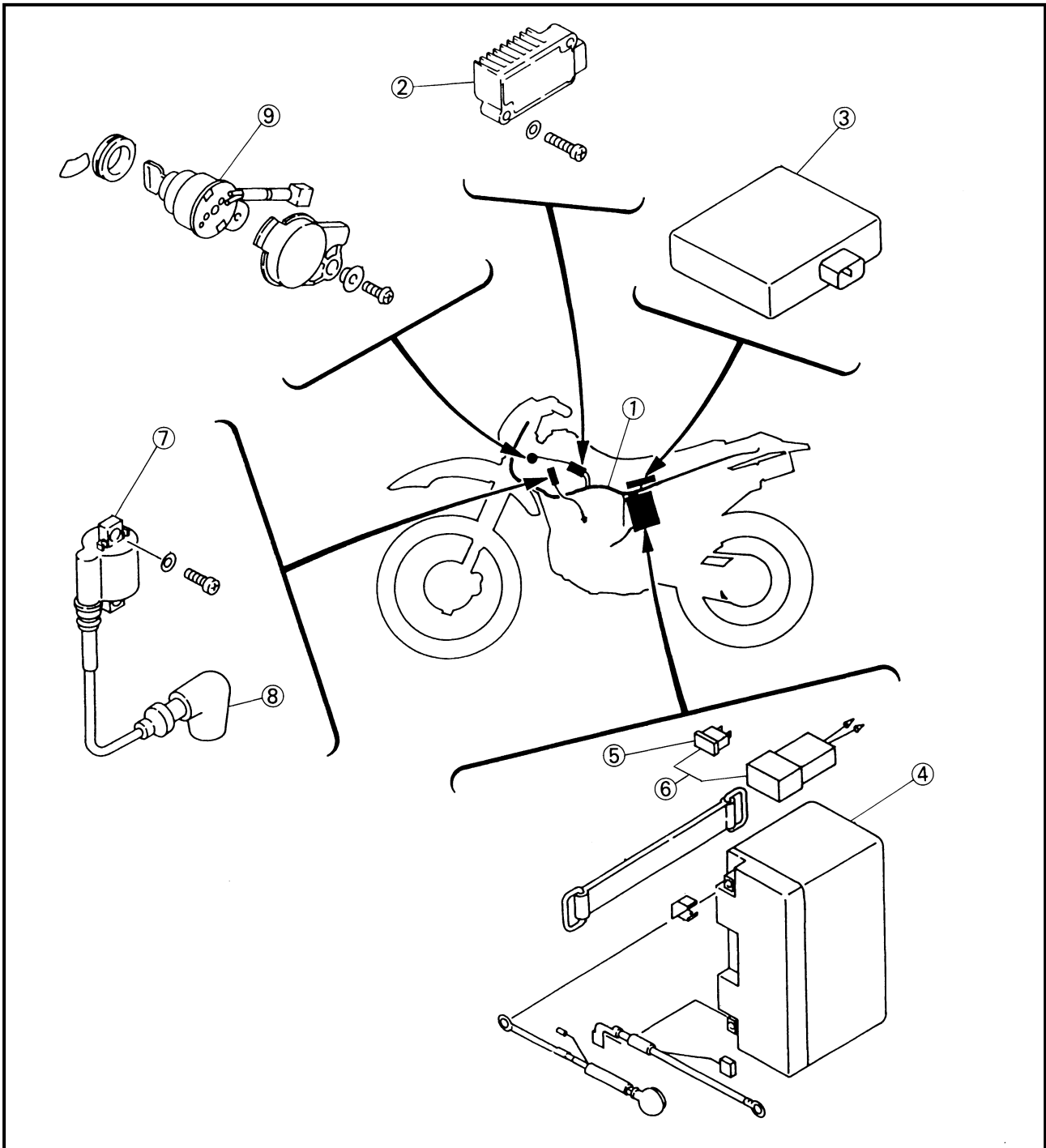

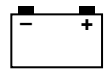

- ① Neutral switch
- ② Starter relay

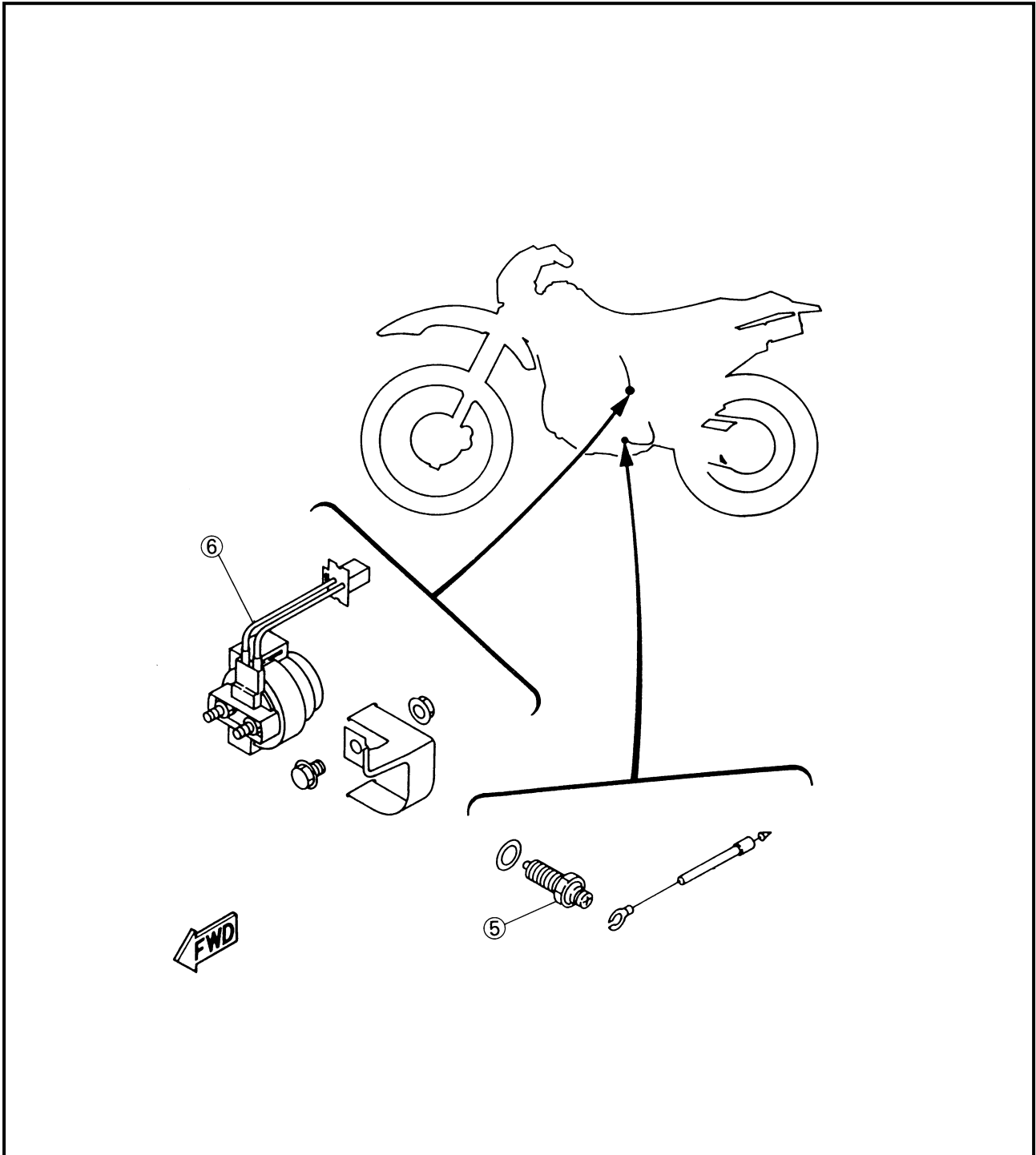

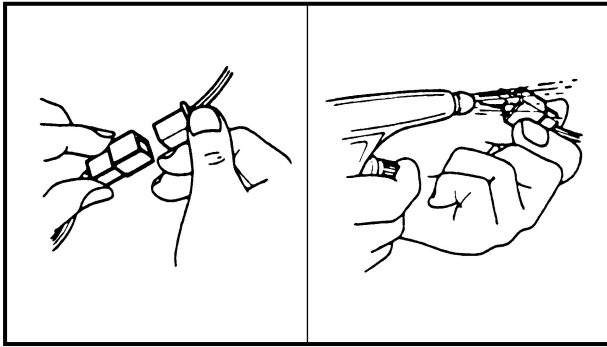
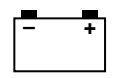

CHECKING OF CONNECTIONS

Dealing with stains, rust, moisture, etc. on the connector.

1. Disconnect:

- Connector

2. Dry each terminal with an air blower.

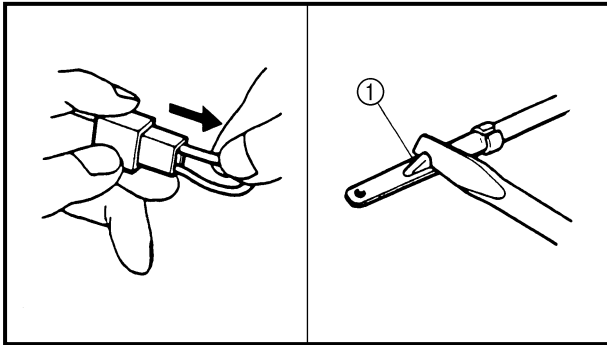

3. Connect and disconnect the connector two or three times.

4. Pull the lead to check that it will not come off.

5. If the terminal comes off, bend up the pin ① and reinsert the terminal into the connector.

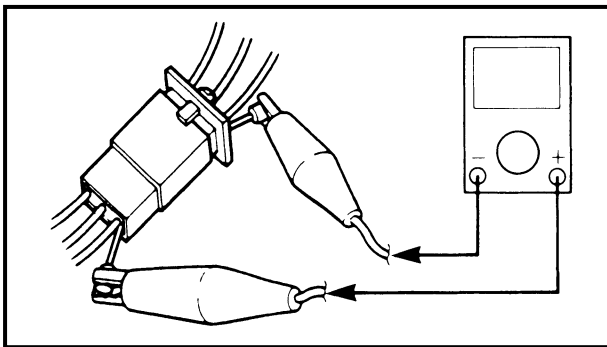

6. Connect:

- Connector

7. Check for continuity with a tester.

NOTE:

- If there is no continuity, clean the terminals.
- Be sure to perform the above steps 1 to 7 when checking the wireharness.
- When replacing the CDI unit, be sure to check its connector.
- For a field remedy, use a contact revitalizer available on the market.
- Use the tester on the connector as shown.

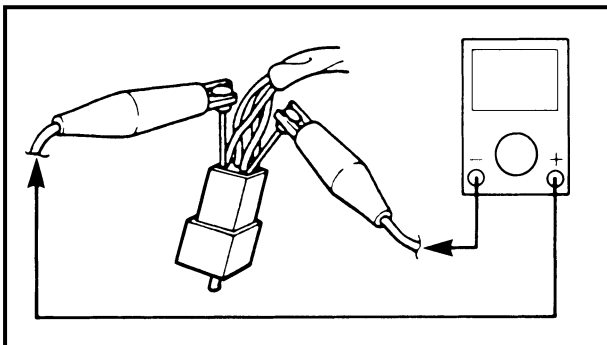

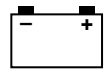

**IGNITION SYSTEM
CIRCUIT DIAGRAM**

- ① AC magneto
- ③ Main switch
- ④ Fuse (main)
- ⑤ Battery
- ⑨ CDI unit
- ⑩ Ignition coil
- ⑪ Spark plug
- ⑫ "ENGINE STOP" switch

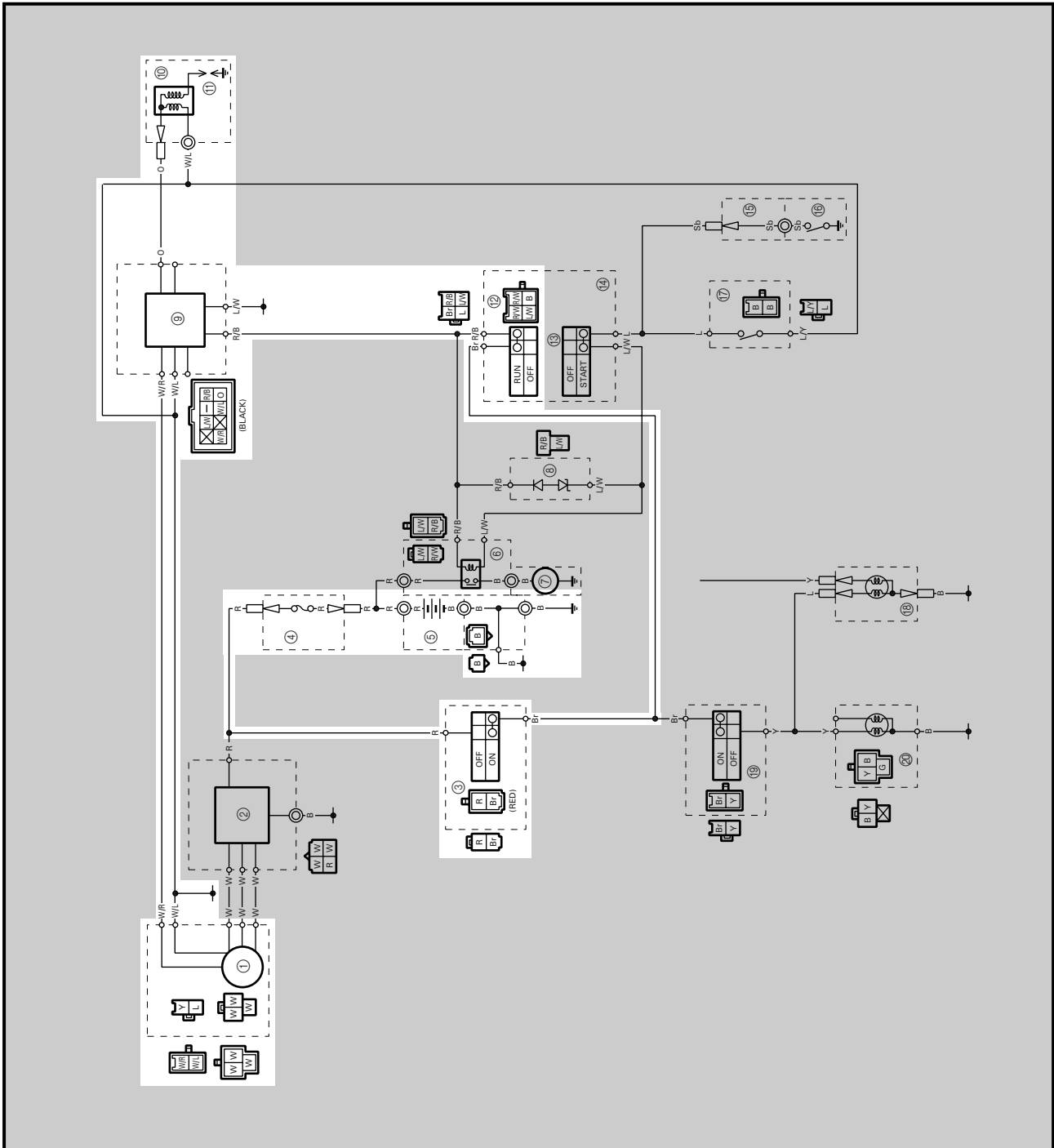

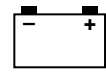

NB283000
TROUBLESHOOTING

**IF THE IGNITION SYSTEM SHOULD BECOME INOPERATIVE
(NO SPARK OR INTERMITTENT SPARK)**

NB283100
Procedure

Check:

- | | |
|---|--|
| <ol style="list-style-type: none"> 1.Fuse (main) 2.Battery 3.Spark plug 4.Ignition spark gap 5.Spark plug cap resistance 6.Ignition coil resistance | <ol style="list-style-type: none"> 7.Main switch 8."ENGINE STOP" switch 9.Pickup coil resistance 10.Wiring connection (entire ignition system) |
|---|--|

NB283110

NOTE:

- Remove the following parts before troubleshooting.
 - 1)Seat
 - 2)Side covers
 - 3)Fuel tank

	<p>Dynamic spark tester: YM-34487</p> <p>Pocket tester: YU-03112</p>
--	--

NB283120

<p>1.Fuse (main)</p> <ul style="list-style-type: none"> • Remove the fuse. • Connect the pocket tester ($\Omega \times 1$) to the fuse. • Check the fuse for continuity.

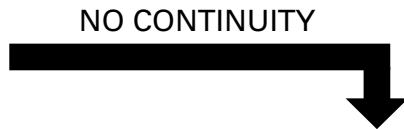

<p>Replace the fuses.</p>

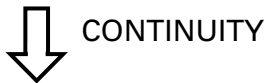

EB283130

<p>2.Battery</p> <ul style="list-style-type: none"> • Check the battery condition. Refer to "BATTERY INSPECTION" in CHAPTER 3.
<p>Open circuit voltage: 12.8 V or more</p>

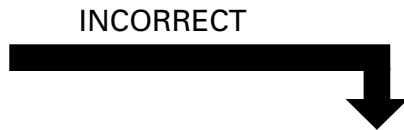

<ul style="list-style-type: none"> • Clean the battery terminals. • Recharge or replace the battery.
--



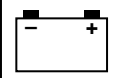

EB283140

3. Spark plug

- Check the spark plug condition.
- Check the spark plug type.
- Check the spark plug gap.
Refer to "SPARK PLUG INSPECTION" in CHAPTER 3.

Standard spark plug:
CR9E (NGK), U27ESR-N (N.D.)



Spark plug gap:
0.7 ~ 0.8 mm (0.028 ~ 0.031 in)



CORRECT

INCORRECT



Repair or replace the spark plug.

NB283150

4. Ignition spark gap

- Disconnect the spark plug cap from the spark plug.
- Connect the dynamic spark tester ① as shown.
- ② Spark plug cap
- ③ Spark plug
- Turn the main switch to "ON".
- Check the ignition spark gap.
- Start the engine, and increase the spark gap until a misfire occurs.



Minimum spark gap:
6.0 mm (0.24 in)



OUT OF SPECIFICATION
OR NO SPARK

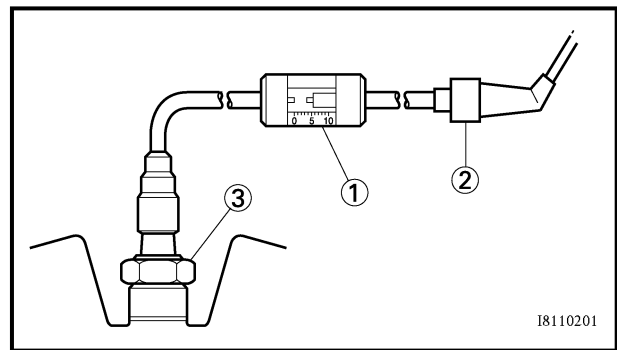

MEETS SPECIFICATION

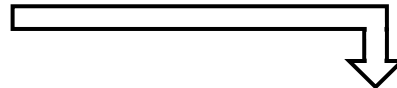

Ignition system is good.

NB283160

5. Spark plug cap resistance

- Remove the spark plug cap.
- Connect the pocket tester ($\Omega \times 1\text{ k}$) to the spark plug cap.

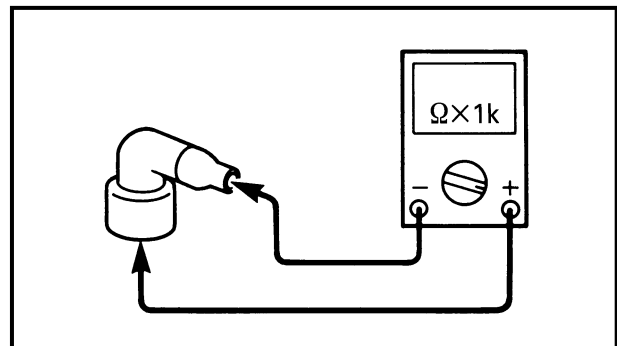

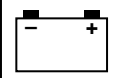

- Check the spark plug cap for specified resistance.



Spark plug cap resistance:
10 kΩ at 20 °C (68 °F)

↓ MEET SPECIFICATION

OUT OF SPECIFICATION

Replace the spark plug cap.

NB283170

6. Ignition coil resistance

- Disconnect the ignition coil leads from the ignition coil.
- Connect the pocket tester ($\Omega \times 1$) to the ignition coil.

Tester (+) lead → (+) Orange lead
Tester (-) lead → (-) Body earth

- Check the primary coil for specified resistance.



Primary coil resistance:
0.36 ~ 0.48 Ω at 20 °C (68 °F)

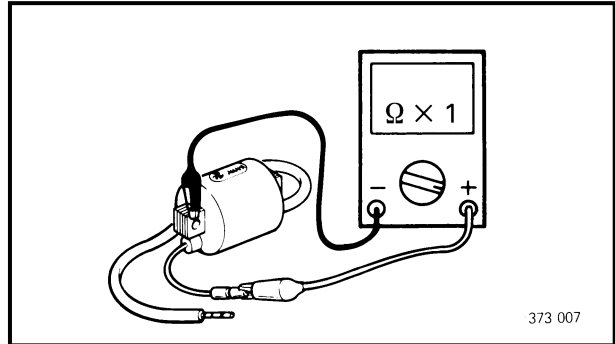

- Connect the pocket tester ($\Omega \times 1\text{ k}$) to the ignition coil.

Tester (+) lead → Spark plug lead
Tester (-) lead → Body earth

- Check the secondary coil for specified resistance.



Secondary coil resistance:
5.44 ~ 7.36 kΩ at 20 °C (68 °F)
(Spark plug lead-spark plug lead)

↓ BOTH MEET SPECIFICATIONS
*

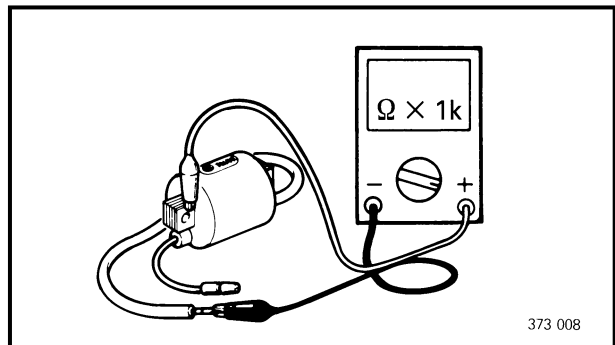

OUT OF SPECIFICATION

Replace the ignition coil.

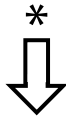
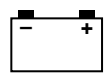

NB283180

7. Main switch

- Disconnect the main switch coupler from the wireharness.
- Check the switch component for continuity between "Red ① and Brown ②".

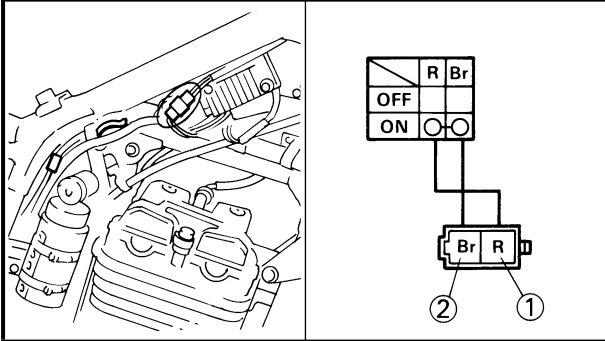

INCORRECT

Replace the main switch.



CORRECT

NB283190

8. "ENGINE STOP" switch

- Disconnect the handlebar switch (right) coupler from the wireharness.
- Check the switch component for continuity between "Red/White ① and Red/White ②".

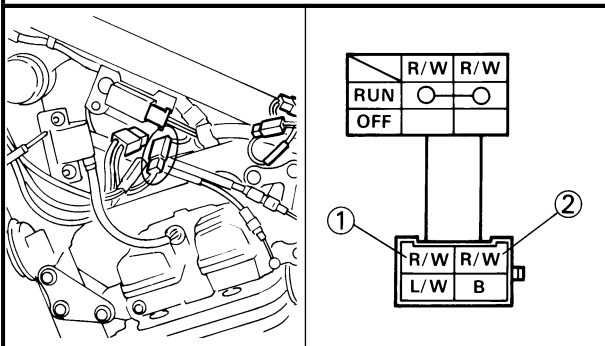

INCORRECT

Replace the handlebar switch (right).



CORRECT

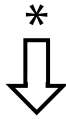
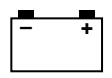

9.Pickup coil resistance

- Disconnect the pickup coil coupler from the wireharness.
- Connect the pocket tester ($\Omega \times 100$) to the pickup coil terminal.

Tester (+) lead → **White/Red** ①
Tester (-) lead → **White/Blue** ②

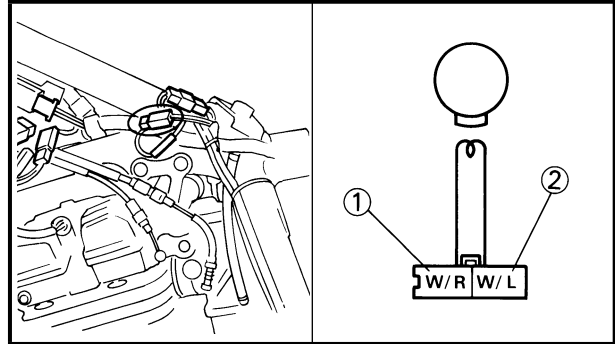

- Check the pickup coil for specified resistance.



Pickup coil resistance:
190 ~ 230 Ω at 20 °C (68 °F)
(White/Red-White/Blue)



OUT OF SPECIFICATION



Replace the pickup coil.

NB283240

10.Wiring connection

- Check the entire ignition system for connections. Refer to "WIRING DIAGRAM".

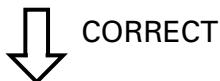
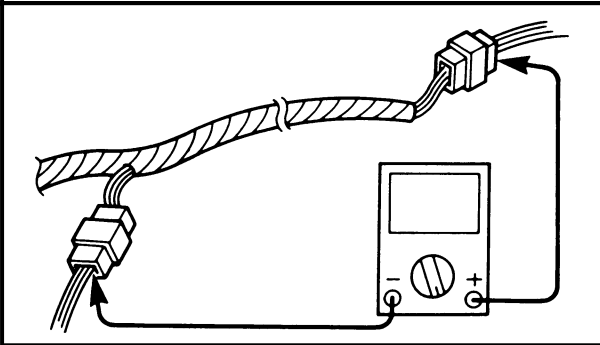

POOR CONNECTION



Correct.

Replace the CDI unit.

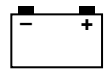

**ELECTRICAL STARTING SYSTEM
CIRCUIT DIAGRAM**

- ③ Main switch
- ④ Fuse (main)
- ⑤ Battery
- ⑥ Starter relay
- ⑦ Starter motor
- ⑧ Diode
- ⑫ "ENGINE STOP" switch
- ⑬ "START" switch
- ⑭ Neutral switch
- ⑮ Clutch switch

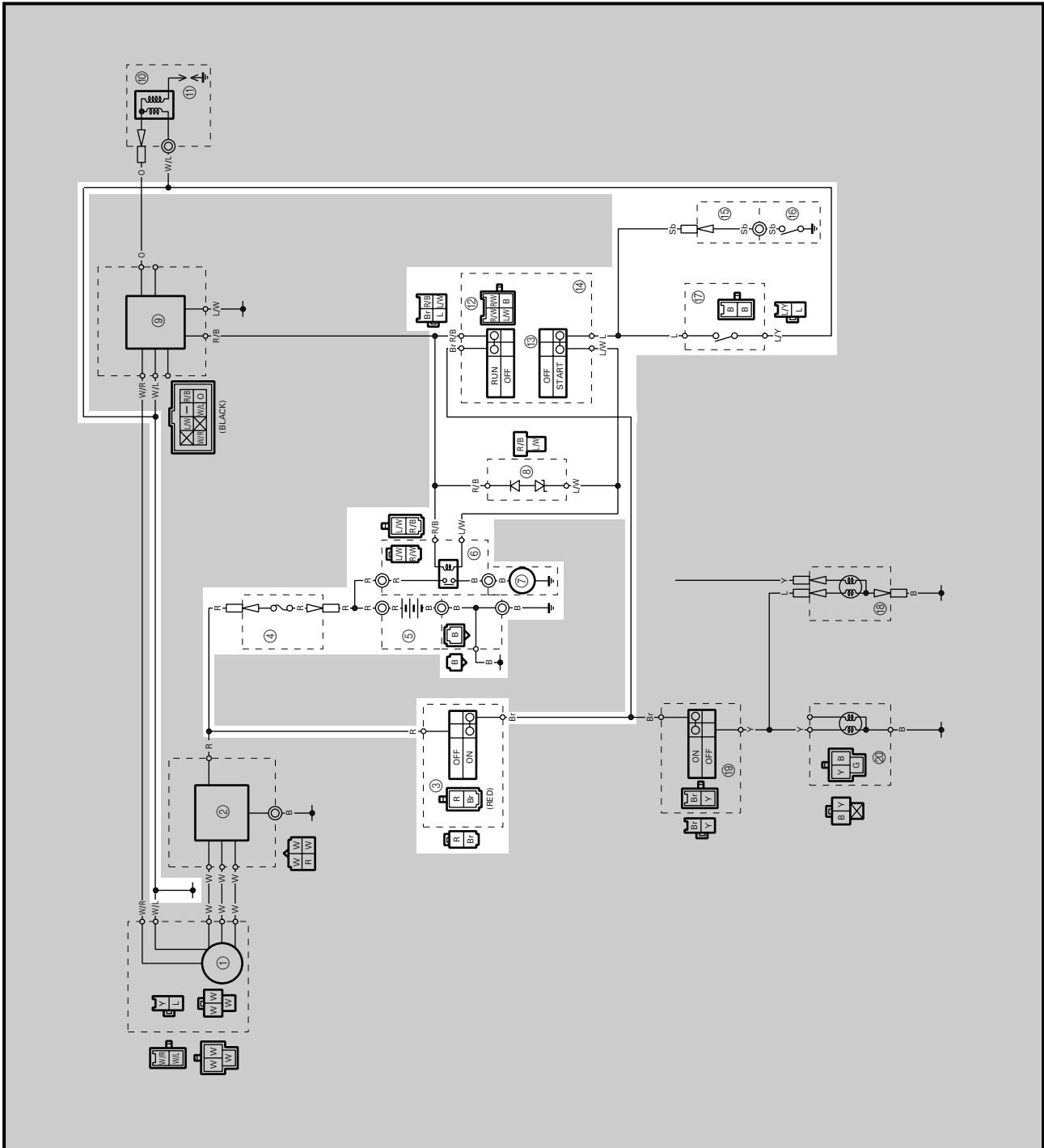

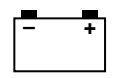

NB284001

STARTING CIRCUIT OPERATION

The starting circuit on this model consist of the starter motor and starter relay. If the "ENGINE STOP" switch and the main switch are both closed, the starter motor can operate only if:

The transmission is in neutral (the neutral switch is closed).
or if
 The clutch lever is pulled to the handlebar (the clutch switch is closed).

The starter relay prevents the starter from operating when neither of these conditions have been met. In this instance, the starter relay is open so current cannot reach the starter motor.

When one of both of the above conditions have been met, however, the starter relay is closed, and the engine can be started by pressing the starter switch.

← WHEN THE TRANSMISSION IS IN NEUTRAL

← WHEN THE CLUTCH LEVER IS PULLED IN

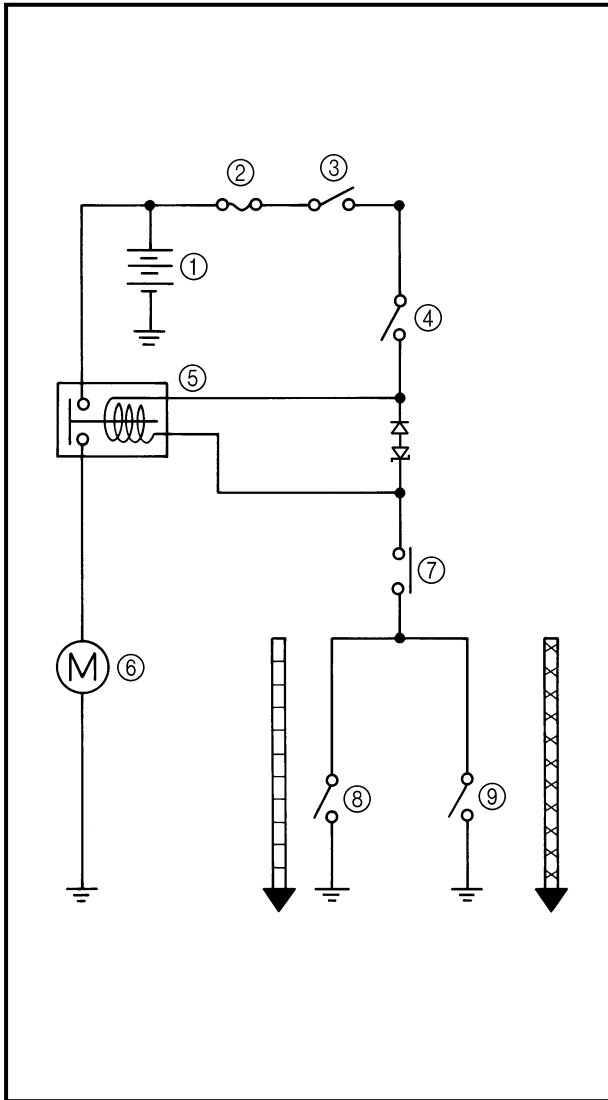

- ① Battery
- ② Fuse
- ③ Main switch
- ④ "ENGINE STOP" switch
- ⑤ Starter relay
- ⑥ Starter motor
- ⑦ "START" switch
- ⑧ Clutch switch
- ⑨ Neutral switch

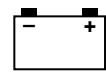

NB284100

TROUBLESHOOTING

STARTER MOTOR DOES NOT OPERATE.

NB284110

Procedure

Check:

- | | |
|---|---|
| <ol style="list-style-type: none"> 1.Fuse (main) 2.Battery 3.Starter motor 4.Starter relay 5.Main switch 6.“ENGINE STOP” switch | <ol style="list-style-type: none"> 7.Neutral switch 8.Clutch switch 9.“START” switch 10.Wiring connection
(entire electric starting system) |
|---|---|

NB284120

NOTE:

Remove the following parts before troubleshooting.

- 1)Seat
- 2)Side covers
- 3)Fuel tank
- 4)Engine guard



Pocket tester:
YU-03112

NB284130

1.Fuse (main)

- Remove the fuse.
- Connect the pocket tester ($\Omega \times 1$) to the fuse.
- Check the fuse for continuity.

NO CONTINUITY



Replace the fuse.

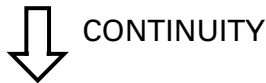

NB284140

2.Battery

- Check the battery condition.
Refer to “BATTERY INSPECTION” in CHAPTER 3.

Open circuit voltage:
12.8 V or more at 20 °C (68 °F)

INCORRECT



- Clean the battery terminals.
- Recharge or replace the battery.



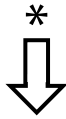
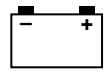

NB284150

3. Starter motor

- Connect the battery positive terminal ① and starter motor cable ② using a jumper lead ③*.
- Check the starter motor for operation.

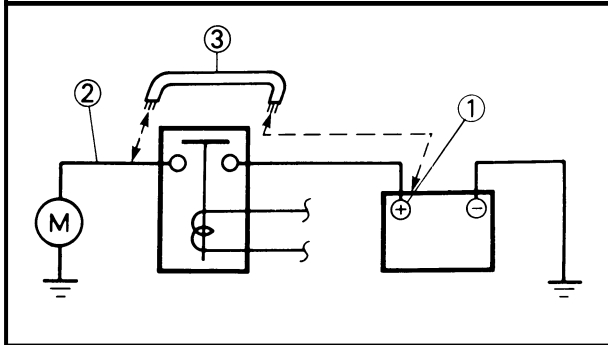

⚠ WARNING

- A wire for jumper lead must have the equivalent capacity as that of the battery lead or more, otherwise it may cause the jumper lead to be burned.
- This check is likely to produce sparks, so be sure that no flammable gas or fluid is in the vicinity.

DOES NOT MOVE



Repair or replace the starter motor.



NB284160

4. Starter relay

- Disconnect the starter relay coupler from the wireharness.
- Connect the starter relay lead "Red/White" ① to the battery positive terminal using the jumper lead ②.
- Ground the starter relay lead "Blue/White" ③ to the frame using the jumper lead ②.
- Check the starter motor for operation.

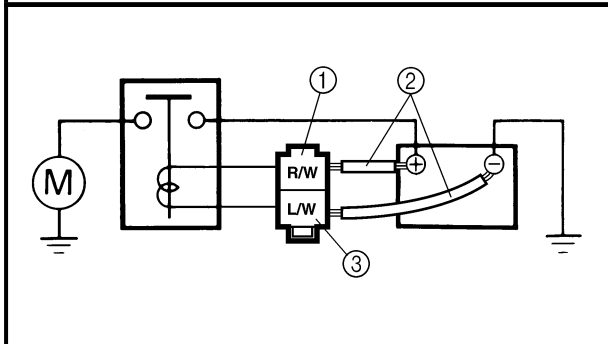

DOES NOT MOVE



Replace the starter relay.

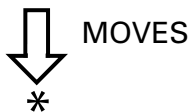

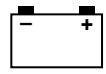

NB284170

5. Main switch

- Disconnect the main switch coupler from the wireharness.
- Check the switch component for continuity between "Red ① and Brown ②".

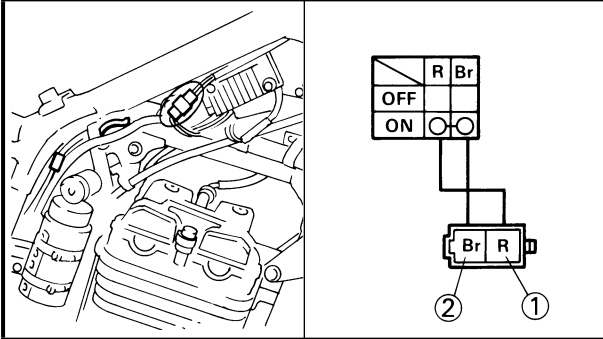

INCORRECT

Replace the main switch.



CORRECT

NB284190

6. "ENGINE STOP" switch

- Disconnect the handlebar switch (right) coupler from the wireharness.
- Check the switch component for continuity between "Red/White ① and Red/White ②".

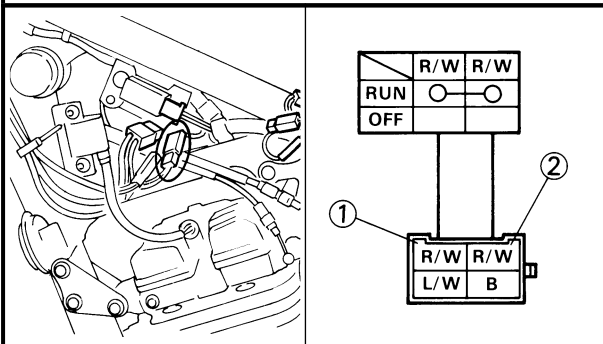

INCORRECT

Replace the handlebar switch (right).



CORRECT

*

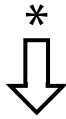
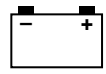

NB284200

7. Neutral switch

- Disconnect the neutral switch lead from the wireharness.
- Check the switch component for continuity between "Sky blue ① and Ground".

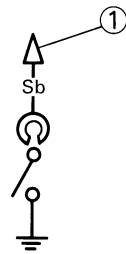
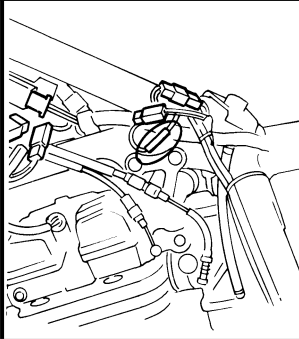

INCORRECT



Replace the neutral switch.



CORRECT

8. Clutch switch

- Disconnect the clutch switch coupler from the wireharness.
- Check the clutch switch component for continuity between "Black ① and Black ②".

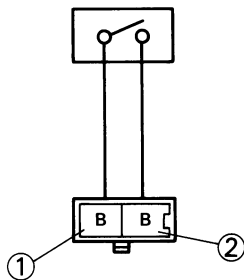
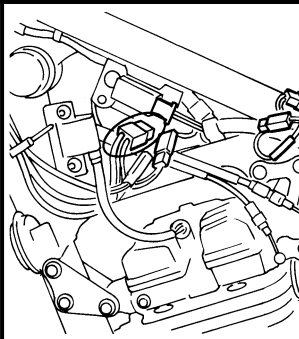

INCORRECT



Replace the clutch switch.



CORRECT

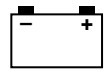

NB284230

9. "START" switch

- Disconnect the handlebar switch (right) coupler from the wireharness.
- Check the "START" switch component for continuity between "Blue/White ① and Black ②".

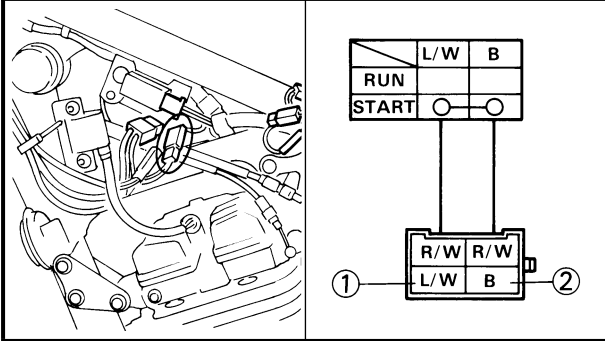

INCORRECT

Replace the handlebar switch (right).



CORRECT

10. Wiring connection

- Check the entire starting system for connections. Refer to "WIRING DIAGRAM".

POOR CONNECTION

Correct.

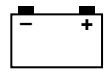
**STARTER MOTOR**

- ① Starter motor lead
- ② Brush
- ③ Bracket
- ④ O-ring
- ⑤ Armature
- ⑥ Yoke

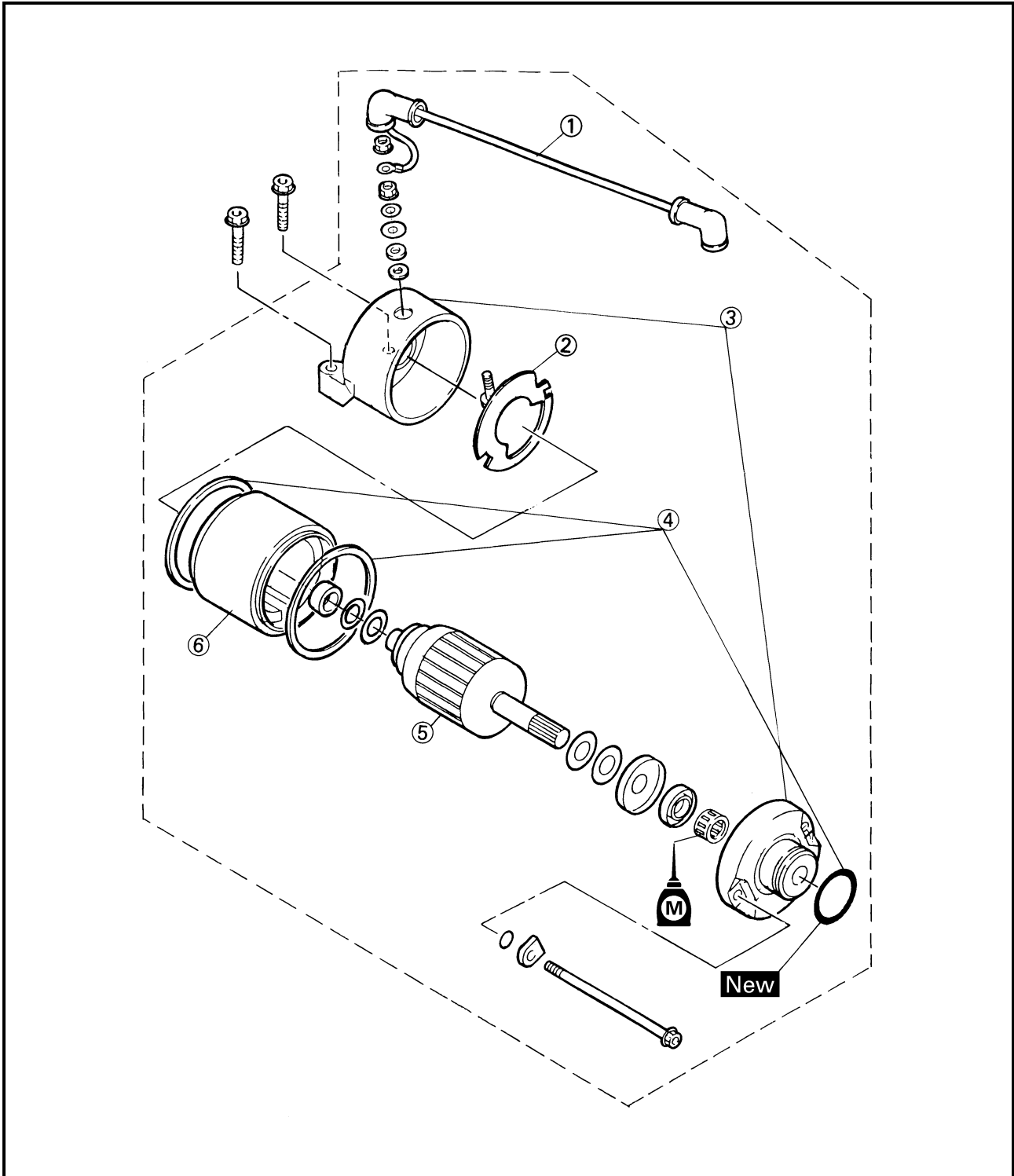

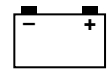

NB284250

Removal

1.Remove:

- Starter motor
Refer to "ENGINE DISASSEMBLY" in CHAPTER 4.

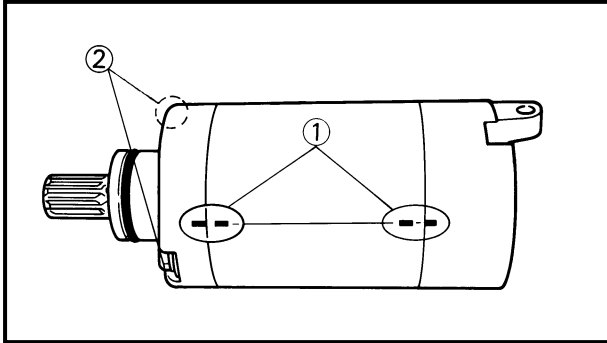

NB284251

Disassembly

1.Put identifying marks ① on the brackets for reassembly as shown.

2.Remove:

- Bolts ②

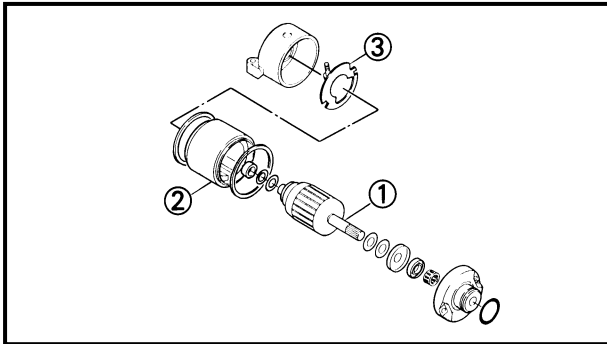

3.Remove:

- Armature ①
- Yoke ②
- Brush ③

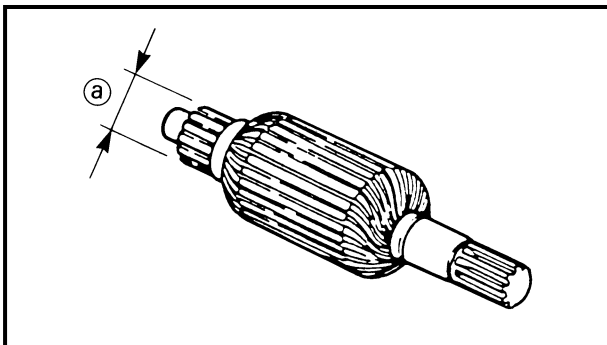

NB284252

Inspection and repair

1.Inspect:

- Commutator

2.Measure:

- Commutator diameter ①
Out of specification → Replace the starter motor.



Commutator wear limit:
27 mm (1.06 in)

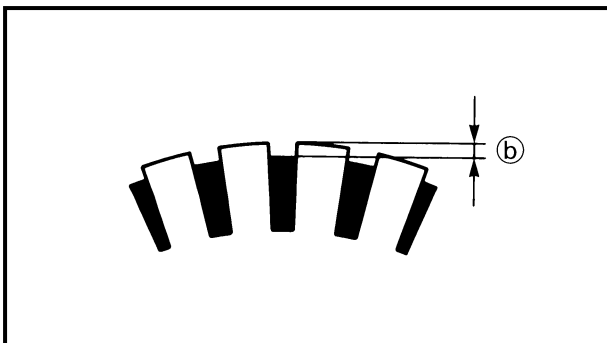

3.Measure:

- Mica undercut ②
Out of specification → Scrape the mica to proper value using a hacksaw blade ground to fit.



Mica undercut:
0.7 mm (0.028 in)

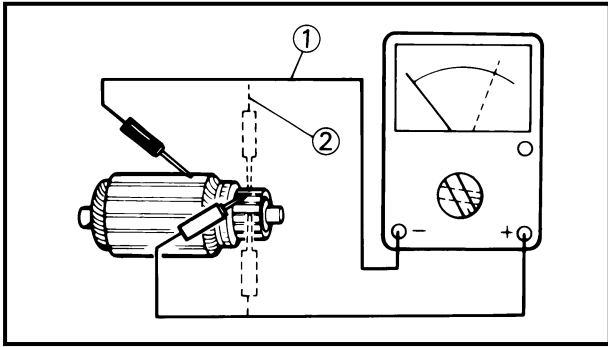
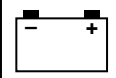

NOTE:

The mica insulation of the commutator must be undercut to ensure proper operation of the commutator.

4. Inspect:

- Armature coil (insulation/continuity)
Defects → Replace the starter motor.

Inspecting steps:

- Connect the pocket tester for continuity check ① and insulation check ②.
- Measure the armature resistances.



Armature coil resistance:

Continuity check ①:

0.0017 ~ 0.0027 Ω at 20 °C (68 °F)

Insulation check ②:

More than 1 MΩ at 20 °C (68 °F)

- If ① resistance is incorrect, replace the starter motor.

5. Measure:

- Brush length ①
Out of specification → Replace.



Brush length limit:

4 mm (0.16 in)

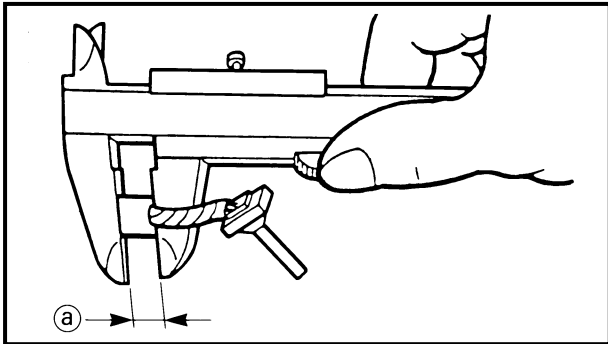

6. Inspect:

- Bearing
- Oil seal
- O-rings
- Bush
Damage → Replace.

Assembly

Reverse the "Removal" procedure. Note the following points.

1. Install:

- Armature ①
- Washers ②

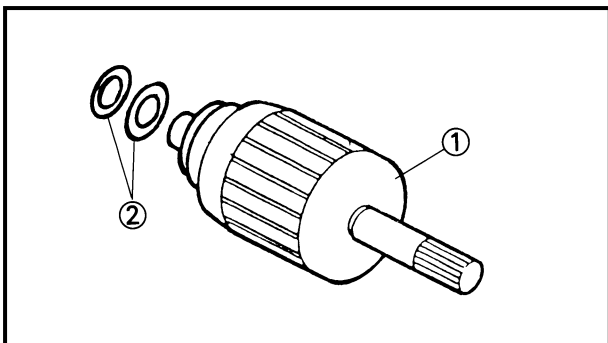

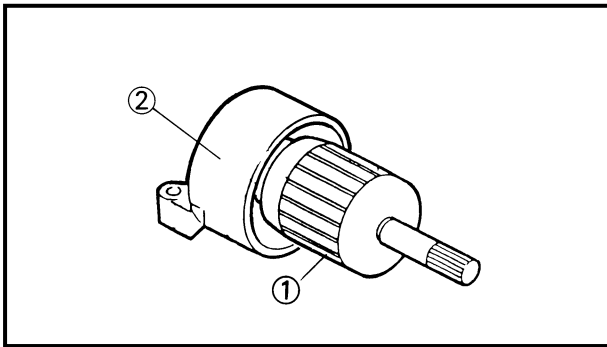
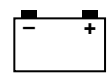

- 2.Install:
- Brush set

NOTE: _____
Align the projection on the brush seat with the slot on the housing.

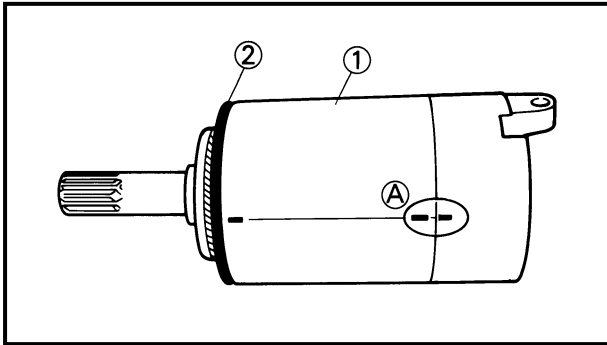

- 3.Install:
- Armature ①
 - Bracket ②

NOTE: _____
When installing the armature, avoid damage to the brush.

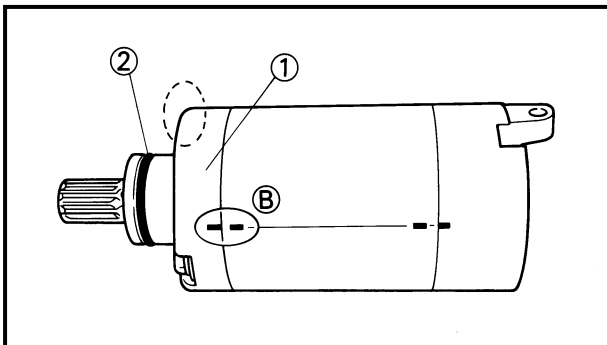

- 4.Install:
- Yoke ①
 - O-ring ②

NOTE: _____
Align the match mark (A) and install.

- 5.Install:
- Bracket ①
 - O-ring ②
- 6.Tighten:
- Bolts

	<p>Bolt: 5 Nm (0.5 m • kg, 3.6 ft • lb)</p>
--	--

NOTE: _____
Align the match mark (B) and install.

Installation

- 1.Install:
- Starter motor

NOTE: _____
Apply a thin coat of grease onto the O-ring.

	<p>Bolt (starter motor): 10 Nm (1.0 m • kg, 7.2 ft • lb)</p>
--	---

Refer to "ENGINE ASSEMBLY" in CHAPTER 4.

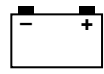

**CHARGING SYSTEM
CIRCUIT DIAGRAM**

- ① A.C. magneto
- ② Rectifier/regulator
- ④ Fuse (main)
- ⑤ Battery

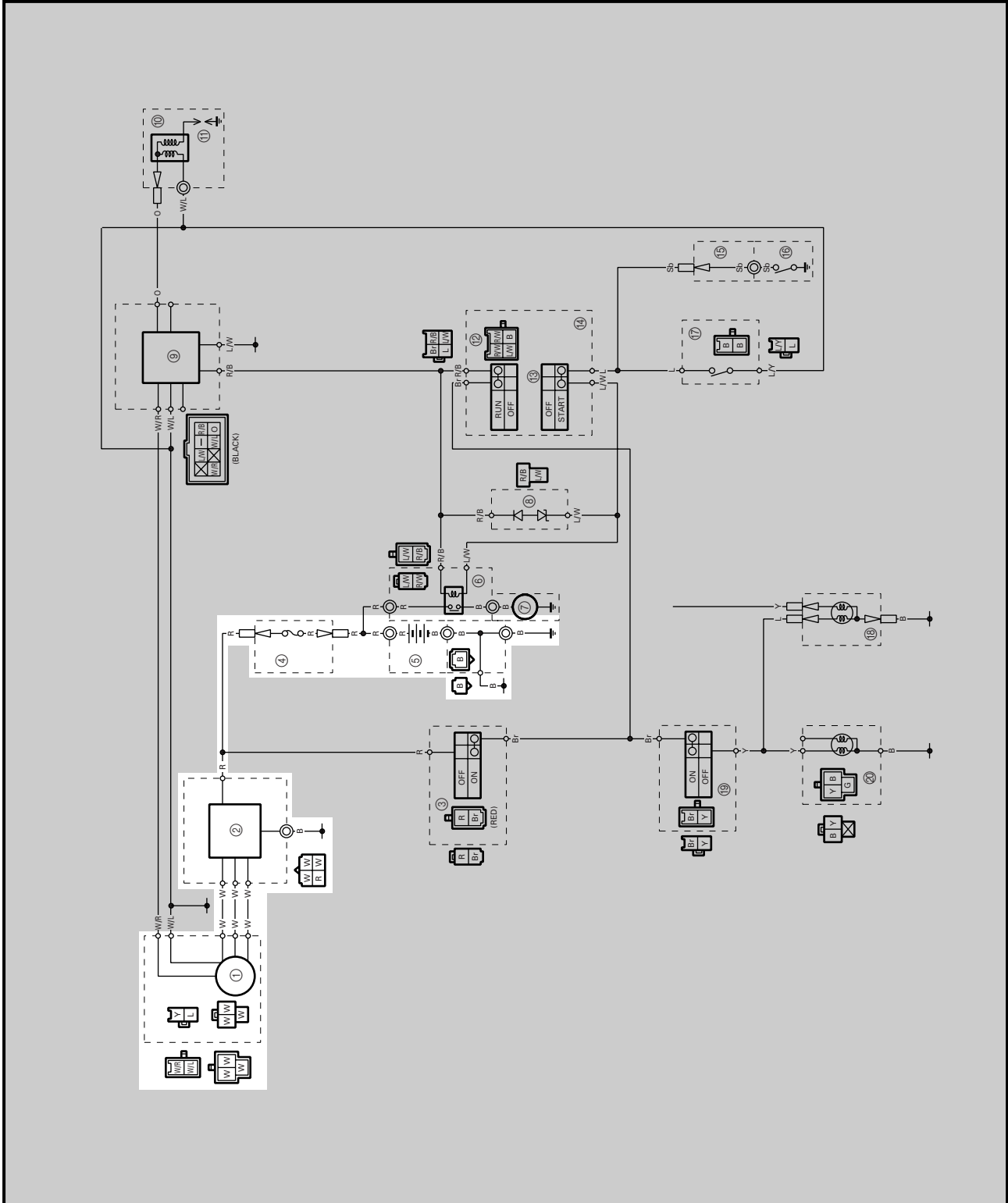

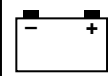

NB285000
TROUBLESHOOTING

THE BATTERY IS NOT CHARGED.

NB285100
Procedure

Check:

- | | |
|--|--|
| <ol style="list-style-type: none"> 1.Fuse (main) 2.Battery 3.Charging voltage | <ol style="list-style-type: none"> 4.Stator coil resistance 5.Wiring connection
(entire charging system) |
|--|--|

NB285110

NOTE:

- Remove the following parts before troubleshooting.
 - 1)Seat
 - 2)Side covers
 - 3)Fuel tank
- Use the following special tool(s) in this troubleshooting.



Inductive tachometer:
YU-8036-A
Pocket tester:
YU-03112

NB285120

1.Fuse (main)
<ul style="list-style-type: none"> • Remove the fuse. • Connect the pocket tester ($\Omega \times 1$) to the fuse. • Check the fuse for continuity.

NO CONTINUITY



Replace the fuse.

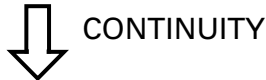

NB285130

2.Battery
<ul style="list-style-type: none"> • Check the battery condition. Refer to "BATTERY INSPECTION" in CHAPTER 3.
Open circuit voltage: 12.8 V or more at 20 °C (68 °F)

INCORRECT



<ul style="list-style-type: none"> • Clean the battery terminals. • Recharge or replace the battery.
--

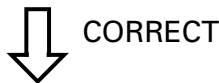

NB285140

3.Charging voltage
<ul style="list-style-type: none"> • Connect the inductive tachometer to the spark plug lead. • Connect the pocket tester (DC 20 V) to the battery.
Tester (+) lead → Battery (+) terminal Tester (-) lead → Battery (-) terminal

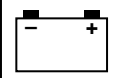

- Start the engine and accelerate to about 3,000 r/min.
- Check the charging voltage.



Charging voltage:
13.0 ~ 15.0 V at 3,000 r/min.

NOTE: _____
Use a fully charged battery.

MEETS SPECIFICATION



Charging circuit is good.

OUT OF SPECIFICATION

NB285150

4. Stator coil resistance

- Disconnect the stator coil coupler from the wireharness.
- Connect the pocket tester ($\Omega \times 1$) to the stator coils.
- Measure the stator coil resistances.

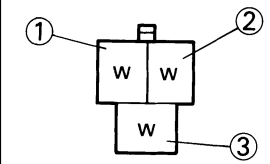
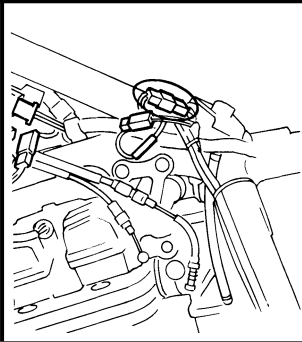

Tester (+) lead → White lead ①
Tester (-) lead → White lead ②

Tester (+) lead → White lead ①
Tester (-) lead → White lead ③



Stator coil resistance:
1.0 ~ 1.2 Ω at 20°C (68°F)

OUT OF SPECIFICATION



Replace the stator assembly.

BOTH MEET SPECIFICATIONS

NB285160

5. Wiring connection

- Check the entire charging system for connections. Refer to "WIRING DIAGRAM".

POOR CONNECTION



Correct.

CORRECT

Replace the rectifier/regulator.

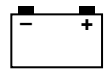

**LIGHTING SYSTEM
CIRCUIT DIAGRAM**

- ③ Main switch
- ④ Fuse (main)
- ⑤ Battery
- ⑱ Tail light
- ⑲ "LIGHTS" switch
- ⑳ Headlight

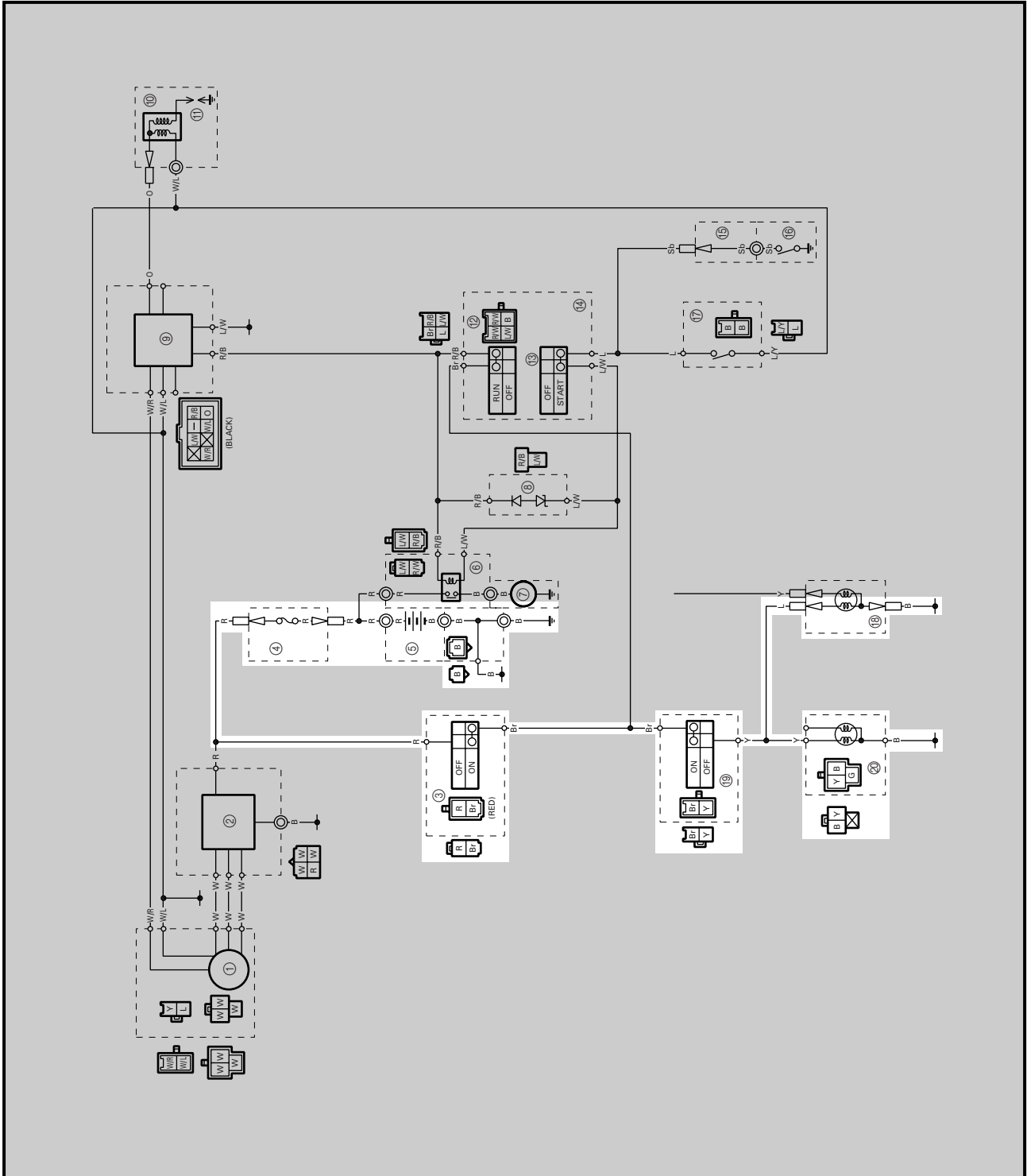

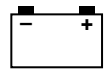

TROUBLESHOOTING

HEADLIGHT, "HIGH BEAM" INDICATOR LIGHT, AND/OR TAILLIGHT DO NOT COME ON

Procedure

Check;

- 1.Fuse (main)
- 2.Battery
- 3.Main switch

- 4."LIGHTS" switch
- 5.Wiring connection (entire charging system)

NB286110

NOTE:

- Remove the following parts before troubleshooting.
 - 1)Seat
 - 2)Side covers
 - 3)Fuel tank
- Use the following special tool(s) in this troubleshooting.



**Pocket tester:
YU-03112**

NB286120

1.Fuse (main)
<ul style="list-style-type: none"> • Remove the fuse. • Connect the pocket tester ($\Omega \times 1$) to the fuse. • Check the fuse for continuity.



Replace the fuse.

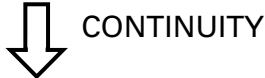

NB286130

2.Battery
<ul style="list-style-type: none"> • Check the battery condition. Refer to "BATTERY INSPECTION" in CHAPTER 3.
Open circuit voltage: 12.8 V or more at 20 °C (68 °F)

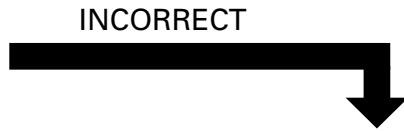

<ul style="list-style-type: none"> • Clean the battery terminals. • Recharge or replace the battery.
--

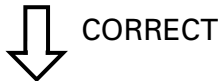

NB286140

3.Main switch
<ul style="list-style-type: none"> • Disconnect the main switch coupler from the wireharness. • Check the switch component for continuity between "Red ① and Brown ②".

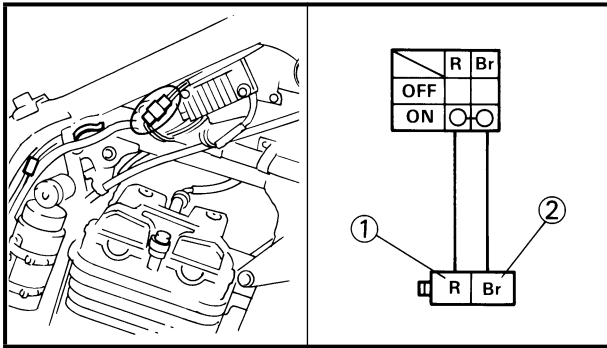
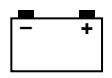

INCORRECT

Replace the main switch.



CORRECT

4. "LIGHTS" switch

- Disconnect the "LIGHTS" switch coupler from the wireharness.
- Check the switch component for continuity between "Brown ① and Yellow ②".

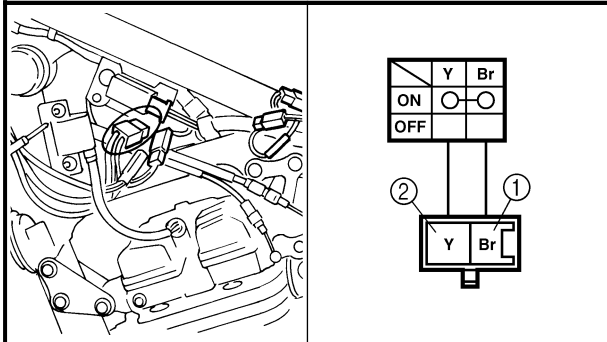

INCORRECT

Replace the handlebar switch (right).



CORRECT

NB286160

5. Wiring connection

- Check the entire lighting system for connections. Refer to "WIRING DIAGRAM".

POOR CONNECTION

Correct.



CORRECT

Check condition of each circuit of the lighting system. Refer to "LIGHTING SYSTEM CHECK".

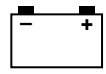

NB286170

LIGHTING SYSTEM CHECK

1.The headlight and “HIGH BEAM” indicator light do not come on.

1.Bulb and bulb socket

- Check the bulb and bulb socket for continuity.

CONTINUITY

NO CONTINUITY

Replace the bulb and/or bulb socket.

NB286180

2.Voltage

- Connect the pocket tester (DC 20 V) to the headlight couplers.

Headlight:
 Tester (+) lead → Yellow ① lead
 Tester (-) lead → Black ② lead

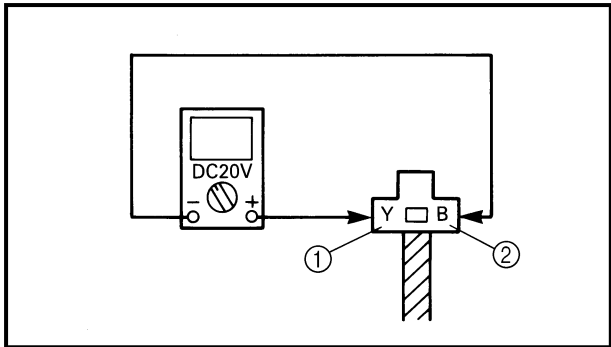

- Turn the main switch to “ON”.
- Turn the “LIGHTS” switch to the “ON” position.
- Check for voltage (12 V) on the “Yellow” lead at the bulb socket connector.

MEETS SPECIFICATION

OUT OF SPECIFICATION

Wiring circuit from main switch to bulb socket connector is faulty, repair.

This circuit is good.

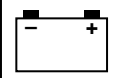

2. Taillight does not come on.

1. Bulb and bulb socket

- Check the bulb and bulb socket for continuity.

↓ CONTINUITY

NB286220

2. Voltage

- Connect the pocket tester (DC 20 V) to the bulb socket connector.

Tester (+) lead → Blue ① terminal
Tester (-) lead → Black ② terminal

- Turn the main switch to "ON".
- Check for voltage (12 V) on the "Blue" lead at the bulb socket connector.

↓ MEETS SPECIFICATION

This circuit is good.

NO CONTINUITY



Replace the bulb and/or bulb socket.

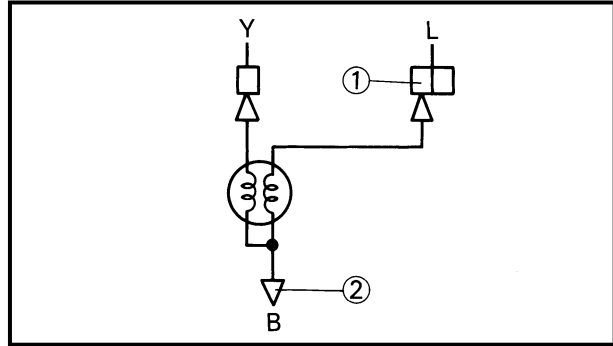

OUT OF SPECIFICATION



Wiring circuit from main switch to bulb socket connector is faulty, repair.

NB291000

TROUBLESHOOTING**NOTE:**

The following troubleshooting does not cover all the possible causes of trouble. It should be helpful, however, as a guide to troubleshooting. Refer to the relative procedure in this manual for inspection, adjustment and replacement of parts.

NB291100

STARTING FAILURE/HARD STARTING**FUEL SYSTEM****Fuel tank**

- Empty
- Clogged fuel filter
- Clogged fuel strainer
- Deteriorated fuel, fuel containing water or foreign material
- Clogged fuel breather hose

Fuel cock

- Clogged fuel hose
- Clogged fuel filter

Air filter element

- Clogged

Carburetor

- Deteriorated fuel, fuel containing water or foreign material
- Clogged pilot jet
- Clogged pilot air passage
- Sucked-in air
- Deformed float
- Groove-worn needle valve
- Improperly sealed valve seat
- Improperly adjusted fuel level
- Improperly set pilot jet
- Clogged starter jet
- Faulty starter plunger
- Improperly adjusted pilot screw

NB291120

ELECTRICAL SYSTEM**Spark plug**

- Improper plug gap
- Worn electrodes
- Severed wire between terminals broken
- Improper heat range
- Faulty spark plug cap

Ignition coil

- Broken or shorted primary/secondary
- Faulty spark plug lead
- Broken body

CDI system

- Faulty CDI unit
- Faulty pickup coil
- Broken woodruff key

COMPRESSION SYSTEM**Cylinder and cylinder head**

- Loose spark plug
- Loose cylinder head or cylinder
- Broken cylinder head gasket
- Worn, damaged or seized cylinder

Crankcase and crankshaft

- Improperly sealed crankcase
- Seized crankshaft

Starter motor

- Faulty starter motor
- Faulty starter relay
- Faulty starter clutch

Switches and wiring

- Faulty main switch
- Faulty "ENGINE STOP" switch
- Broken or shorted wiring
- Faulty neutral switch
- Faulty "START" switch
- Faulty clutch switch

Valve and camshaft

- Improperly sealed valve
- Improper valve to valve seat contact
- Improper valve timing
- Broken valve spring
- Seized camshaft

Piston and piston ring

- Improperly installed piston ring
- Worn, fatigued or broken piston ring
- Seized piston ring
- Seized or damaged piston

POOR IDLE SPEED PERFORMANCE

POOR IDLE SPEED PERFORMANCE

Carburetor

- Improperly returned starter plunger
- Loose pilot jet
- Clogged pilot air jet
- Improperly adjusted idle speed (throttle stop screw/air screw)
- Improper throttle cable free play
- Flooded carburetor

Electrical system

- Faulty battery
- Faulty spark plug
- Faulty CDI unit
- Faulty pickup coil
- Faulty ignition coil

Valve train

- Improperly adjusted valve clearance

NB292120

POOR MEDIUM AND HIGH SPEED PERFORMANCE

POOR MEDIUM AND HIGH SPEED PERFORMANCE

Refer to "Starting failure/Hard starting".

(FUEL SYSTEM, ELECTRICAL SYSTEM, COMPRESSION SYSTEM AND VALVE TRAIN)

Carburetor

- Improper jet needle clip position
- Diaphragm malfunction
- Improperly adjusted fuel level
- Clogged or loose main jet

Air filter

- Clogged air filter element

NB293100

FAULTY GEAR SHIFTING

HARD SHIFTING

Refer to "CLUTCH DRAGGING".

NB293120

SHIFT PEDAL DOES NOT MOVE

Shift shaft

- Bent shift shaft

Shift cam, shift fork

- Groove jammed with impurities
- Seized shift fork
- Bent shift fork guide bar

NB293140

JUMP-OUT GEAR

Shift shaft

- Improperly adjusted shift lever position
- Improperly returned stopper lever

Shift fork

- Worn shift fork

Transmission

- Seized transmission gear
- Jammed impurities
- Incorrectly assembled transmission

Shift cam

- Improper thrust play
- Worn shift cam groove

Transmission

- Worn gear dog

NB294100

CLUTCH SLIPPING/Dragging

CLUTCH SLIPPING

Clutch

- Improperly adjusted clutch cable
- Loose clutch spring
- Fatigued clutch spring
- Worn friction plate
- Worn clutch plate
- Incorrectly assembled clutch

Engine oil

- Low oil level
- Improper quality (low viscosity)
- Deterioration

NB294120

CLUTCH DRAGGING

Engine oil

- High oil level
- Improper quality (high viscosity)
- Deterioration

Clutch

- Warped clutch plate
- Unevenly tensioned clutch spring
- Match mark not aligned
- Loose clutch boss nut
- Burnt primary driven gear bushing
- Bent clutch plate
- Swollen friction plate
- Broken clutch boss



NB295100

OVERHEATING

OVERHEATING

Ignition system

- Improper spark plug gap
- Improper spark plug heat range
- Faulty ignition coil

Compression system

- Heavy carbon built-up

Brake

- Dragging brake

Fuel system

- Improper carburetor main jet (improper setting)
- Improperly adjusted fuel level
- Clogged air filter element

Engine oil

- Incorrect oil level
- Improper oil viscosity
- Inferior oil quality

FAULTY BRAKE

POOR BRAKING EFFECT

Disc brake

- Worn brake pad
- Worn brake disc
- Air in brake fluid
- Leaking brake fluid
- Faulty cylinder kit cup
- Faulty caliper kit seal
- Loose union bolt
- Broken brake hose
- Oily or greasy brake disc
- Oily or greasy brake pad
- Improper brake fluid level

FRONT FORK OIL LEAKAGE AND FRONT FORK MALFUNCTION

OIL LEAKAGE

- Bent, damaged or rusty inner tube
- Damaged or cracked outer tube
- Damaged oil seal lip
- Improperly installed oil seal
- Improper oil level (too much)
- Loose damper rod holding bolt
- Broken cap bolt O-ring
- Loose drain bolt
- Damaged drain bolt gasket

MALFUNCTION

- Bent, deformed or damaged inner tube
- Bent or deformed outer tube
- Damaged fork spring
- Worn or damaged slide metal
- Bent or damaged damper rod
- Improper oil viscosity
- Improper oil level

INSTABLE HANDLING

INSTABLE HANDLING

Handlebars

- Improperly installed or bent

Tires

- Uneven tire pressures on both sides
- Incorrect tire pressure
- Unevenly worn tires

Front forks

- Uneven oil level on both sides
- Uneven spring tension
(uneven damping adjuster position)
- Broken spring
- Twisted front fork

Drive chain

- Improperly adjusted chain slack

Swingarm

- Worn bearing or bush
- Bent or damaged

Rear shock absorber

- Fatigued spring
- Improperly adjusted spring preload
- Oil and gas leakage

Steering

- Improperly installed upper bracket
- Bent steering stem
- Improperly installed steering stem
(improperly tightened ring nut)
- Damaged bearing or bearing race

Wheels

- Incorrect wheel balance
- Deformed cast wheel
- Loose bearing
- Bent or loose wheel axle
- Excessive wheel run-out

Frame

- Twisted
- Damaged head pipe
- Improperly installed bearing race

NB299100

FAULTY SIGNAL AND LIGHTING SYSTEM

HEADLIGHT DARK

- Improper bulb
- Too many electric accessories
- Hard charging (broken stator coil and/or faulty rectifier/regulator)
- Incorrect connection
- Improperly grounded
- Poor contact (main or "LIGHTS" switch)
- Bulb life expired

BULB BURNT OUT

- Improper bulb
- Faulty battery
- Faulty rectifier/regulator
- Improperly grounded
- Faulty main and/or "LIGHTS" switch
- Bulb life expired

TTR250L(C) WIRING DIAGRAM

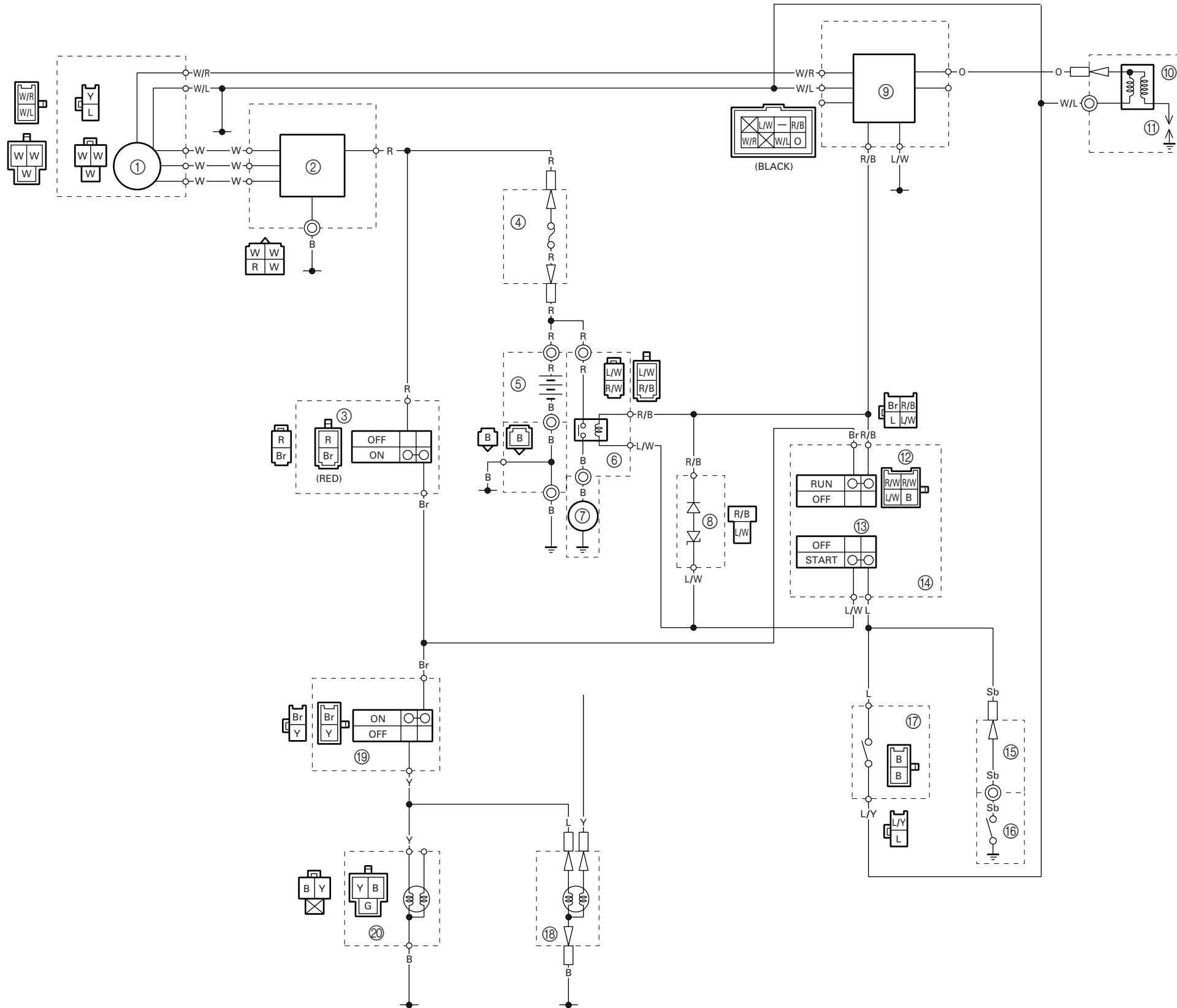

- ① AC magneto
- ② Rectifier/regulator
- ③ Main switch
- ④ Fuse (main)
- ⑤ Battery
- ⑥ Starter relay
- ⑦ Starter motor
- ⑧ Diode
- ⑨ CDI unit
- ⑩ Ignition coil
- ⑪ Spark plug
- ⑫ "ENGINE STOP" switch
- ⑬ "START" switch
- ⑭ Handlebar switch (right)
- ⑮ Wire sub lead
- ⑯ Neutral switch
- ⑰ Clutch switch
- ⑱ Tail light
- ⑲ "LIGHTS" switch
- ⑳ Headlight

COLOR CODE

B	Black
Br	Brown
G	Green
L	Blue
O	Orange
R	Red
Sb	Sky blue
W	White
Y	Yellow
L/W	Blue/White
L/Y	Blue/Yellow
R/B	Red/Black
R/W	Red/White
W/L	White/Blue
W/R	White/Red