



PARTS CATALOGUE

TTR230V (1C65) U.S.A.

TTR230V (1C66) CANADA

TTR230V (1C67) AUSTRALIA

TTR230V
PARTS CATALOGUE
©2005 by Yamaha Motor Co., Ltd.
1st edition, July 2005
All rights reserved.
Any reprinting or unauthorized use
without the written permission of
Yamaha Motor Co., Ltd.
is expressly prohibited.
Printed in Japan.

A3

FOREWORD

This Parts Catalogue is related to the parts for the model(s) on the cover page. When you are ordering replacement parts, please refer to this Parts Catalogue and quote both part numbers and part names correctly.

1. Modifications or additions which have been made after the issue of the Parts Catalogue will be announced in the Parts News.

It is advisable that you make the necessary corrections to the Parts Catalogue according to the Parts News.

2. Abbreviations

The following abbreviations are used in this Parts Catalogue.

“UR” Use specified parts number.

“UN” Use as many as needed.

“AP” Alternate Parts

“LM” Locally Made (Parts need to be ordered locally)

“F#” Frame No. (Applicable machine No.)

“O/S” Over Size

3. The number of components for assembly

- Parts, which are to be supplied in an assembly, are listed with a dot (.) in front of the part name as shown below.
- The numeral appearing to the right of each component part indicates the quantity of parts for each assembly unit.

PART NO.	DESCRIPTION	Q'TY	REMARKS
2F5-83310-60	FRONT FLASHER LIGHT ASSY	2	
115-83311-60	.BULB (6V-18W)	1	

4. Applicable colours of graphics are represented in the “REMARKS” as shown below.

PART NO.	DESCRIPTION	Q'TY	REMARKS
2N4-24110-00-X5	FUEL TANK COMP.	2	MXR
3J1-24240-10	.GRAPHIC, FUEL TANK	1	FOR MXR

5. Note that the illustrations for reference in finding parts numbers are not to be used for assembling. When assembling, please use the applicable service manual.

6. The asterisk (*) before a reference number indicates modified items after the first edition.

FOREWORD

7. Applicable Serial No.

Engine Serial No.

Frame Serial No.

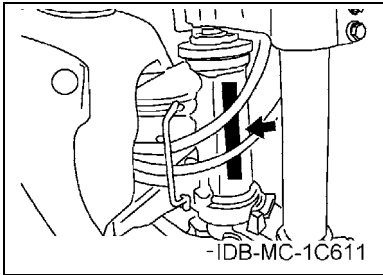
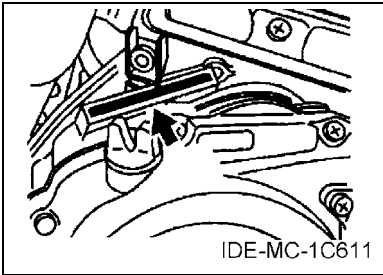

8. Applicable Colour Code (The (*) mark shows Model colour.)

Abbreviation	Colour Name	Colour Code
CIS	CIRCUIT SILVER	00WN
DPBSE(*)	DEEP PURPLISH BLUE SOLID E	0583
SL	SILVER	0035

CONTENTS

ENGINE

CYLINDER HEAD	B2
CYLINDER	B3
CRANKSHAFT & PISTON	B4
VALVE	B6
CAMSHAFT & CHAIN	B7
OIL PUMP	B8
INTAKE	B9
CARBURETOR	B10
EXHAUST	B12
CRANKCASE	B13
CRANKCASE COVER 1	B14
STARTER CLUTCH	B15
CLUTCH	C2
TRANSMISSION	C4
SHIFT CAM & FORK	C6
SHIFTER	C7

CHASSIS

FRAME	C8
FENDER	C10
SIDE COVER	C12
REAR ARM	C13
REAR SUSPENSION	C15
STEERING	D2
FRONT FORK	D3
FUEL TANK	D5
SEAT	D7
FRONT WHEEL	D8
FRONT BRAKE CALIPER	D9
REAR WHEEL	D10
STEERING HANDLE & CABLE	D12
FRONT MASTER CYLINDER	D13
STAND & FOOTREST	D14
GENERATOR	E2
STARTING MOTOR	E3
HANDLE SWITCH & LEVER	E4
ELECTRICAL 1	E5

INDEX

NUMERICAL INDEX	M1
-----------------------	----

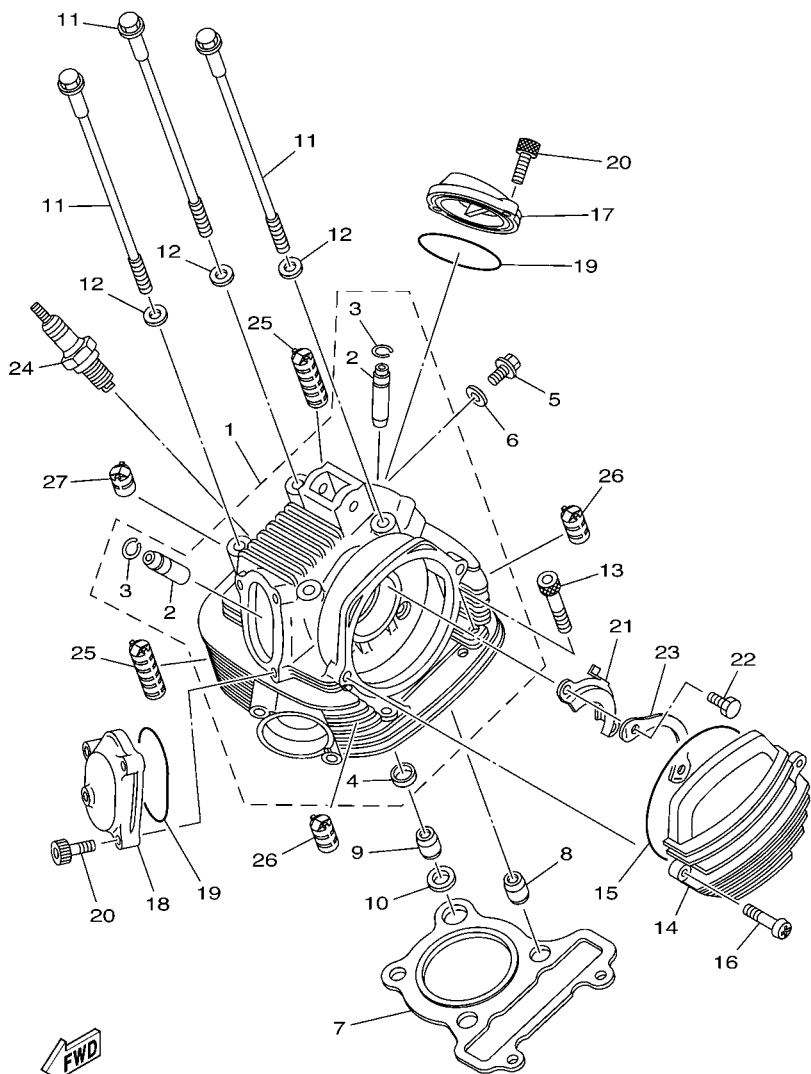

FWD
4BES100-0010

FIG. 1 CYLINDER HEAD

REF. NO.	PART NO.	DESCRIPTION	1C65	1C66	1C67	REMARKS
1	1C6-11101-00	CYLINDER HEAD ASSY	1	1	1	
2	5H0-11133-11	.GUIDE, VALVE 1	2	2	2	
3	93440-10085	.CIRCLIP	2	2	2	
4	90385-12039	.BUSH	1	1	1	
5	90153-06029	SCREW, HEXAGON	1	1	1	
6	90430-06014	GASKET	1	1	1	
7	59V-11181-00	GASKET, CYLINDER HEAD 1	1	1	1	
8	91810-16016	PIN, DOWEL	2	2	2	
9	93612-16254	PIN, DOWEL	1	1	1	
10	90430-12186	GASKET	1	1	1	
11	90105-08195	BOLT, FLANGE	4	4	4	
12	90201-08609	WASHER, PLATE	4	4	4	
13	9131M-08045	BOLT	2	2	2	
14	4VW-E1185-10	COVER, CYLINDER HEAD SIDE 1	1	1	1	
15	93211-05471	O-RING	1	1	1	
16	9502M-06020	BOLT, FLANGE	2	2	2	
17	4VW-E1186-10	COVER, CYLINDER HEAD SIDE 2	1	1	1	
18	4VW-E1187-10	COVER, CYLINDER HEAD SIDE 3	1	1	1	
19	93210-57634	O-RING	2	2	2	
20	9131M-06018	BOLT	5	5	5	
21	5H0-1111F-00	PLATE	1	1	1	
22	9700M-06012	BOLT	2	2	2	
23	90215-06184	WASHER, LOCK	1	1	1	
24	94700-00333	PLUG, SPARK (NGK DR8EA)	1	1	1	
25	15A-11162-00	ABSORBER 2	2	2	2	
26	5H0-11162-00	ABSORBER 2	2	2	2	
27	15A-11161-01	ABSORBER 1	1	1	1	

FIG. 2 CYLINDER

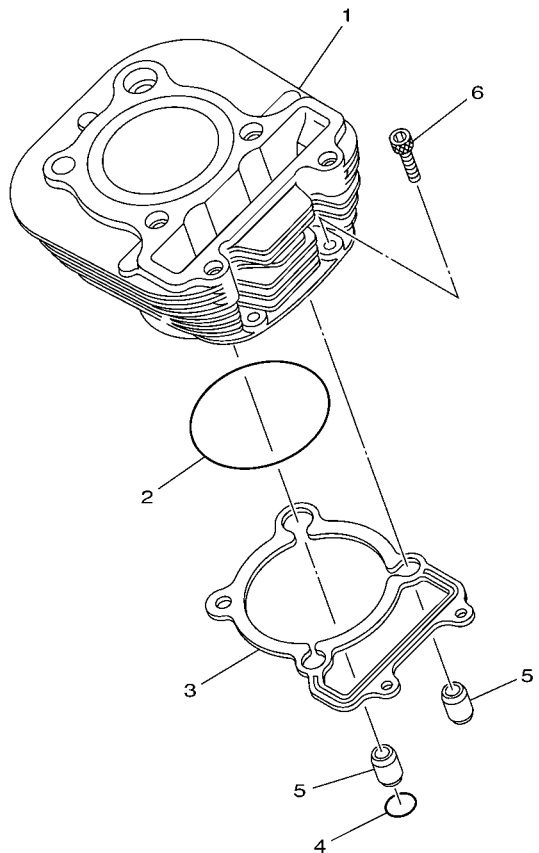

REF. NO.	PART NO.	DESCRIPTION	1C65	1C66	1C67	REMARKS
1	4VW-11310-00	CYLINDER	1	1	1	
2	93210-72529	O-RING	1	1	1	
3	5VC-11351-00	GASKET, CYLINDER	1	1	1	
4	93210-13361	O-RING	1	1	1	
5	91810-16016	PIN, DOWEL	2	2	2	
6	9131M-06025	BOLT	2	2	2	

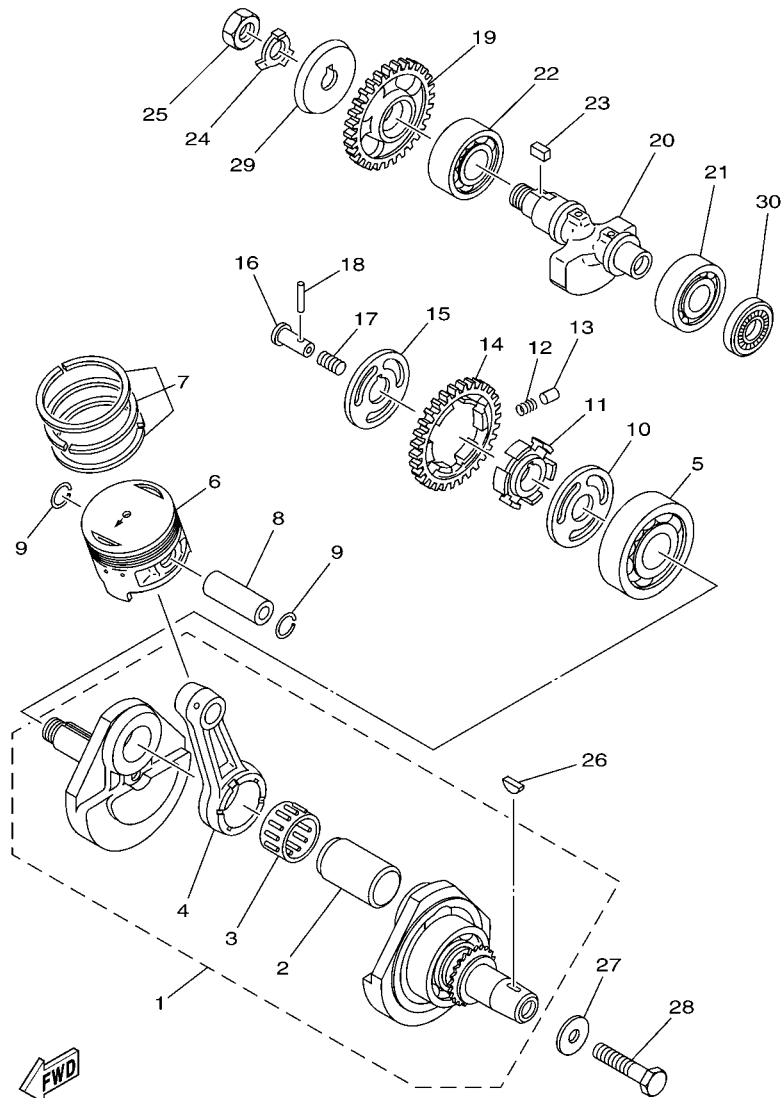

4BES100-0020



4BES100-0030

FIG. 3 CRANKSHAFT & PISTON

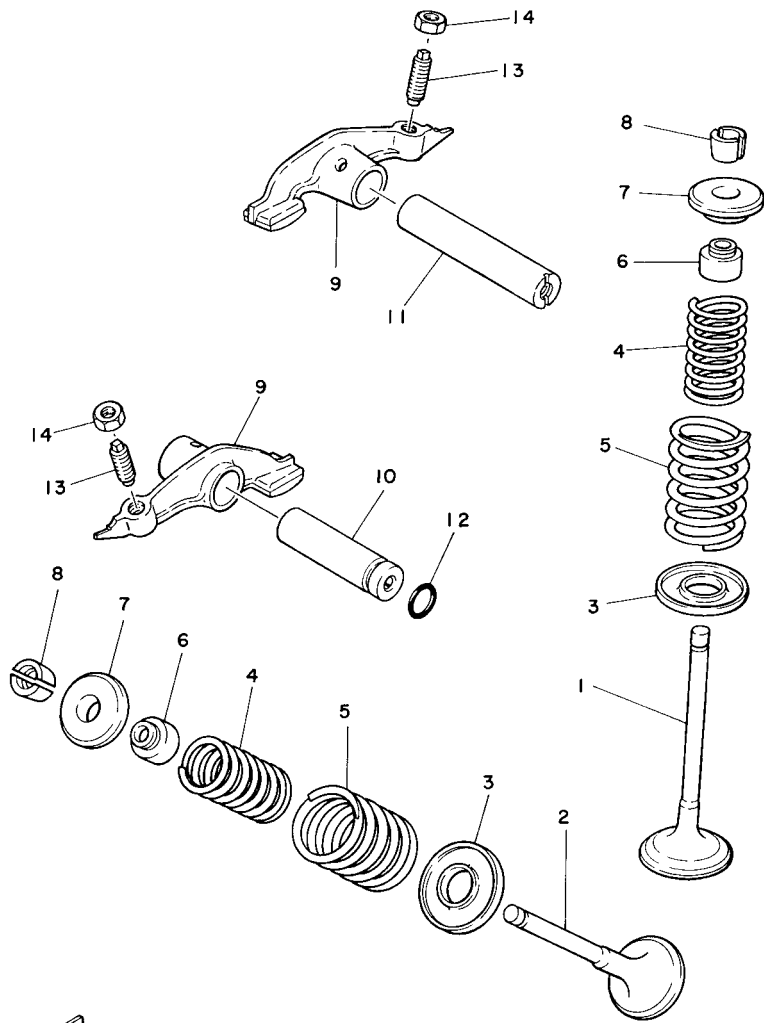
REF. NO.	PART NO.	DESCRIPTION	1C65	1C66	1C67	REMARKS
1	3RW-11400-00	CRANKSHAFT ASSY	1	1	1	
2	5H0-11681-00	.PIN, CRANK 1	1	1	1	
3	93310-530J3	.BEARING	1	1	1	
4	29U-11651-00	.ROD, CONNECTING	1	1	1	
5	93306-30611	BEARING	1	1	1	
6	1KH-11631-01-C0	PISTON (STD)	1	1	1	
	1KH-11636-01	PISTON (0.50MM O/S)	1	1	1	AP
	1KH-11638-01	PISTON (1.00MM O/S)	1	1	1	AP
7	29U-11610-00	PISTON RING SET (STD)	1	1	1	
	29U-11610-20	PISTON RING SET (0.50MM O/S)	1	1	1	AP
	29U-11610-40	PISTON RING SET (1.00MM O/S)	1	1	1	AP
8	15A-11633-00	PIN, PISTON	1	1	1	
9	93450-17044	CIRCLIP	2	2	2	
10	90201-201E4	WASHER, PLATE	1	1	1	
11	5H0-11496-00	BOSS, BUFFER	1	1	1	
12	90501-21133	SPRING, COMPRESSION	6	6	6	
13	93605-10090	PIN, DOWEL	3	3	3	
14	5H0-11536-00	GEAR, DRIVE (38T)	1	1	1	
15	90214-20023	WASHER, CLAW	1	1	1	
16	90240-07083	PIN, CLEVIS	1	1	1	
17	90501-07629	SPRING, COMPRESSION	1	1	1	
18	93602-13177	PIN, DOWEL	1	1	1	
19	2LN-11530-00	BALANCER WEIGHT GEAR COMP.	1	1	1	
20	1KH-11454-00	WEIGHT 1	1	1	1	
21	93306-20532	BEARING	1	1	1	
22	93306-30427	BEARING	1	1	1	
23	90282-05013	KEY, STRAIGHT	1	1	1	



1KH010-6040

FIG. 4 VALVE

REF. NO.	PART NO.	DESCRIPTION	1C65	1C66	1C67	REMARKS
1	5H0-12111-02	VALVE, INTAKE	1	1	1	
2	5H0-12121-01	VALVE, EXHAUST	1	1	1	
3	4G0-12116-01	SEAT, VALVE SPRING	2	2	2	
4	11H-12113-00	SPRING, VALVE INNER	2	2	2	
5	11H-12114-00	SPRING, VALVE OUTER	2	2	2	
6	5H0-12119-00	SEAL, VALVE STEM	2	2	2	
7	4G0-12117-00	RETAINER, VALVE SPRING	2	2	2	
8	4G0-12118-00	COTTER, VALVE	4	4	4	
9	29U-12151-00	ARM, VALVE ROCKER	2	2	2	
10	5H0-12156-00	SHAFT, ROCKER 2	1	1	1	
11	5H0-12146-00	SHAFT, ROCKER	1	1	1	
12	93210-09165	O-RING	1	1	1	
13	2NX-12159-00	SCREW, VALVE ADJUSTING	2	2	2	
14	90170-06128	NUT	2	2	2	

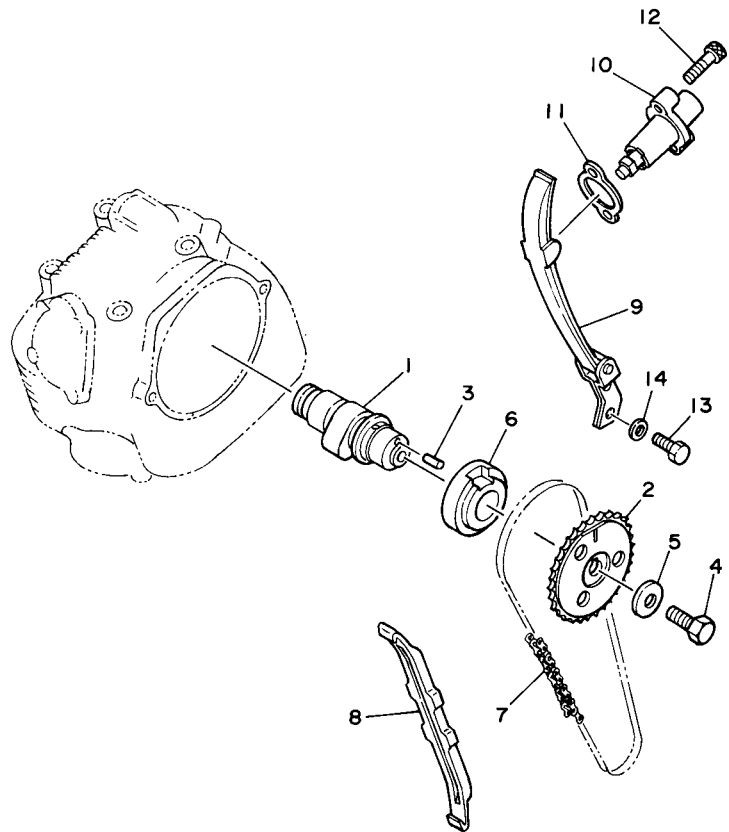

FIG. 5 CAMSHAFT & CHAIN

REF. NO.	PART NO.	DESCRIPTION	1C65	1C66	1C67	REMARKS
1	1KH-12171-00	CAMSHAFT 1	1	1	1	
2	2LN-12176-00	SPROCKET, CAM CHAIN (40T)	1	1	1	
3	93604-10011	PIN, DOWEL	1	1	1	
4	90101-10303	BOLT	1	1	1	
5	90201-10591	WASHER, PLATE	1	1	1	
6	90387-255F3	COLLAR	1	1	1	
7	94580-41104	CHAIN (DID25SH 104L)	1	1	1	
8	5H0-12231-00	GUIDE, STOPPER 1	1	1	1	
9	5N0-12241-00	GUIDE, STOPPER 2	1	1	1	
10	2HT-12210-10	TENSIONER ASSY, CAM CHAIN	1	1	1	
11	4FM-12213-00	GASKET, TENSIONER CASE	1	1	1	
12	9131M-06025	BOLT	2	2	2	
13	97027-06016	BOLT	2	2	2	
14	92907-06600	WASHER, PLATE	2	2	2	



3RW1010-0050

FIG. 6 OIL PUMP

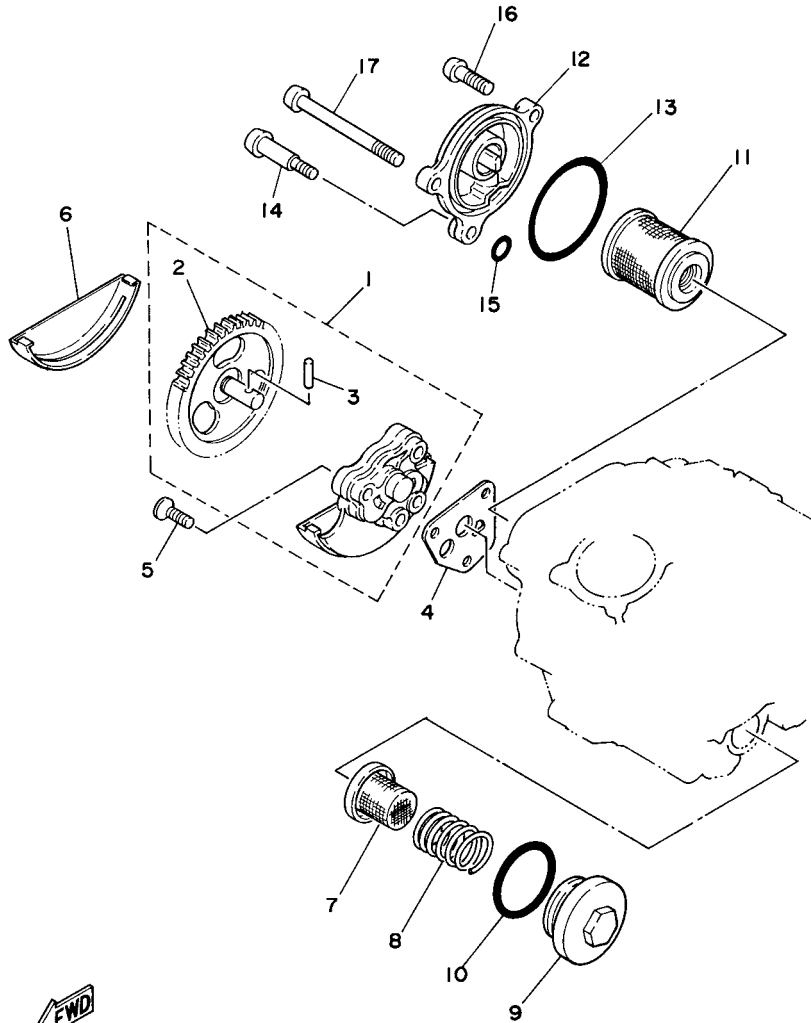

IKH010-6060

REF. NO.	PART NO.	DESCRIPTION	1C65	1C66	1C67	REMARKS
1	5H0-13300-02	OIL PUMP ASSY	1	1	1	
2	5H0-13326-01	.GEAR, PUMP DRIVEN 2 (45T)	1	1	1	
3	93603-12030	.PIN, DOWEL	1	1	1	
4	4BE-13329-01	GASKET, PUMP COVER	1	1	1	
5	9870M-06030	SCREW, FLAT HEAD	3	3	3	
6	5H0-13327-00	COVER, PUMP GEAR	1	1	1	
7	51Y-13411-00	STRAINER, OIL	1	1	1	
8	90501-18576	SPRING, COMPRESSION	1	1	1	
9	4VW-E5351-00	PLUG, DRAIN	1	1	1	
10	93210-347A1	O-RING	1	1	1	
11	5H0-13440-00	ELEMENT ASSY, OIL CLEANER	1	1	1	
12	4VW-E3447-00	COVER, OIL ELEMENT	1	1	1	
13	93210-54175	O-RING	1	1	1	
14	90109-065G0	BOLT	1	1	1	
15	93210-07135	O-RING	1	1	1	
16	9502M-06025	BOLT, FLANGE	1	1	1	
17	90105-064A6	BOLT, FLANGE	1	1	1	

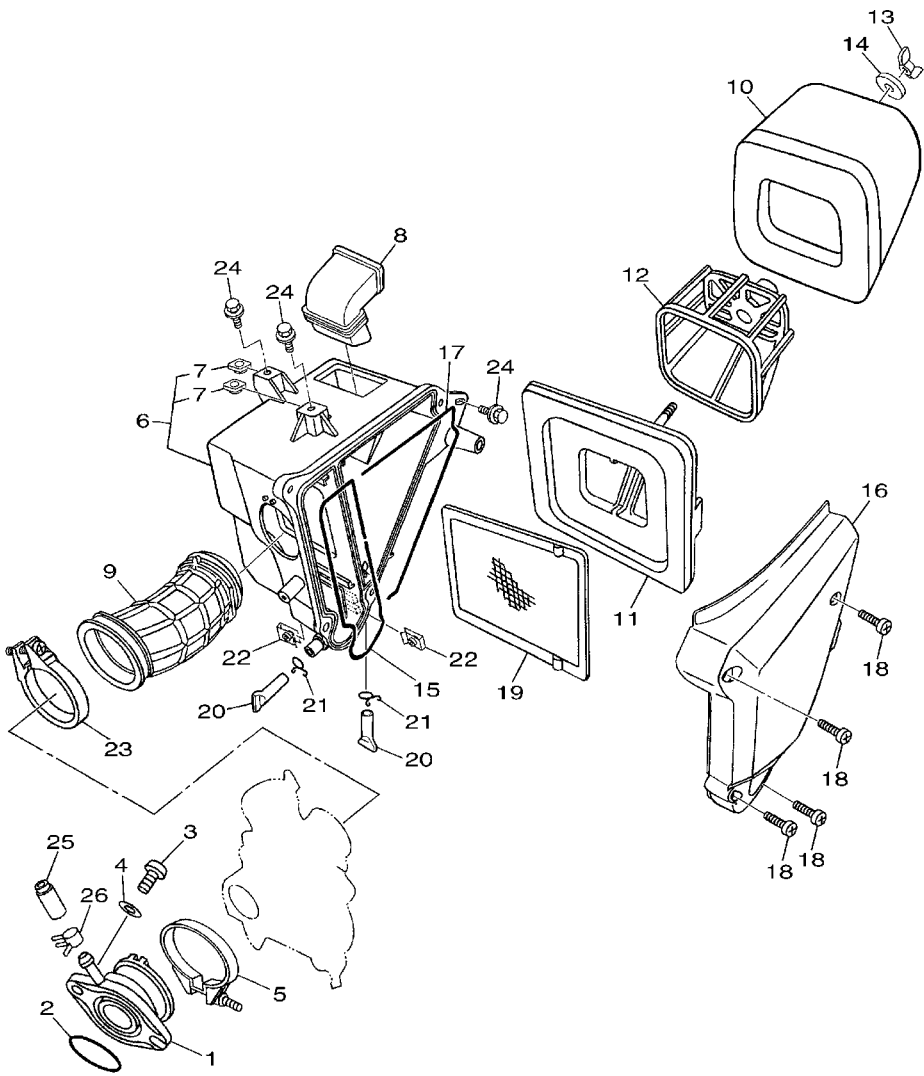

1C61100-D070

FIG. 7 INTAKE

REF. NO.	PART NO.	DESCRIPTION	1C65	1C66	1C67	REMARKS
1	1C6-E3586-00	JOINT, CARBURETOR 1	1	1	1	
2	93210-35537	O-RING	1	1	1	
3	9131M-06020	BOLT	2	2	2	
4	9290M-06600	WASHER	1	1	1	
5	90460-46206	CLAMP, HOSE	1	1	1	
6	1C6-E4411-00	CASE, AIR CLEANER 1	1	1	1	
7	1B2-E4477-00	.PLATE	2	2	2	
8	1C6-E4453-00	JOINT, AIR CLEANER 1	1	1	1	
9	1C6-E4437-00	DUCT	1	1	1	
10	1C6-14451-00	ELEMENT, AIR CLEANER	1	1	1	
11	1C6-E4459-00	HOLDER, GUIDE	1	1	1	
12	1C6-E4458-00	GUIDE	1	1	1	
13	90175-06012	NUT, WING	1	1	1	
14	90201-06735	WASHER, PLATE	1	1	1	
15	1C6-E4462-00	SEAL	1	1	1	
16	1C6-E4412-00	CAP, CLEANER CASE 1	1	1	1	
17	1C6-E4452-00	SEAL	1	1	1	
18	9890M-06020	SCREW, BIND	4	4	4	
19	1C6-E4472-00	PLATE, ELEMENT	1	1	1	
20	5HH-E443E-01	PIPE, DRAIN	2	2	2	
21	90467-15012	CLIP	2	2	2	
22	90183-06023	NUT, SPRING	2	2	2	
23	90460-49293	CLAMP, HOSE	1	1	1	
24	90119-06044	BOLT, WITH WASHER	3	3	3	
25	16G-13569-00	PLUG, BLIND	1	1	1	
26	90467-10039	CLIP	1	1	1	

FIG. 8 CARBURETOR

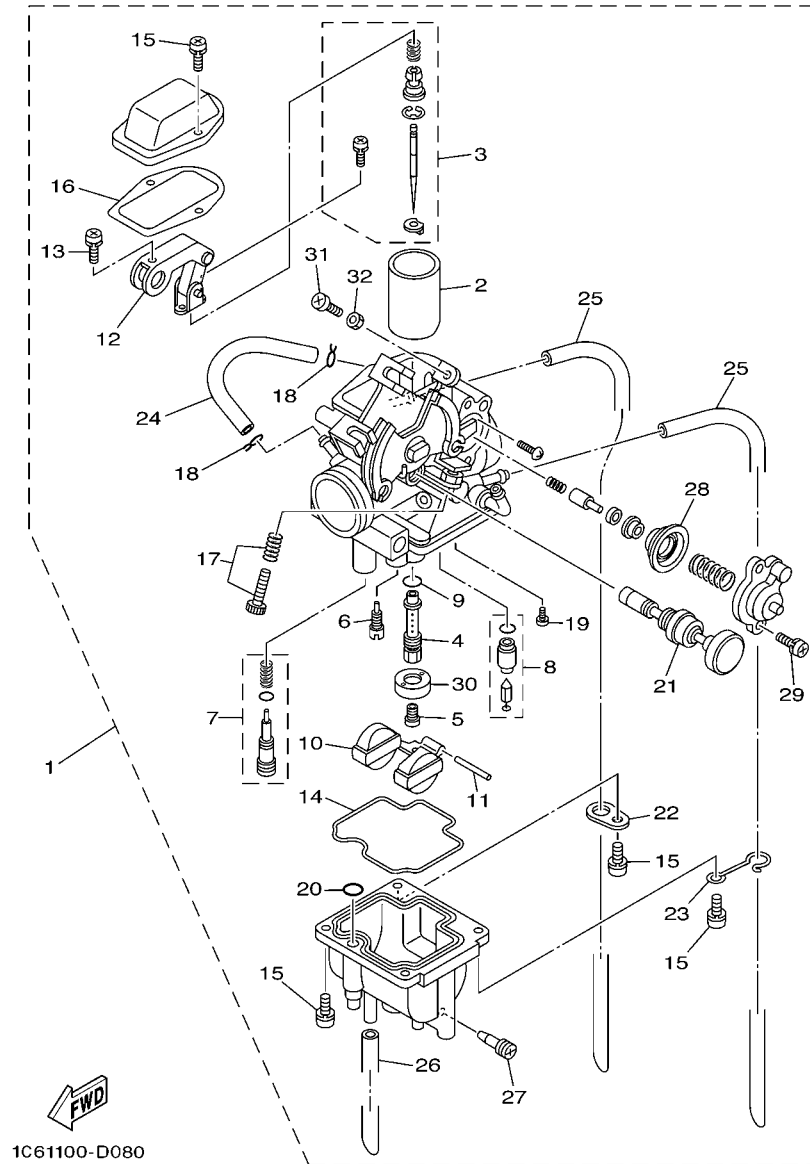

1C61100-D080

REF. NO.	PART NO.	DESCRIPTION	1C65	1C66	1C67	REMARKS
1	1C6-14301-00	CARBURETOR ASSY 1	1	1	1	
2	1XL-14313-28	.VALVE, THROTTLE 2	1	1	1	
3	1C6-1490J-00	.NEEDLE SET	1	1	1	
4	1C6-14341-00	.NOZZLE, MAIN	1	1	1	
5	288-14343-63	.JET, MAIN (#125)	1	1	1	
6	1C6-14342-18	.JET, PILOT (#36)	1	1	1	
7	1C6-14105-00	.PILOT SCREW SET	1	1	1	
8	4KL-14390-20	.NEEDLE VALVE ASSY	1	1	1	
9	360-24512-00	.GASKET	1	1	1	
10	5Y1-14385-00	.FLOAT	1	1	1	
11	689-14386-00	.PIN, FLOAT	1	1	1	
12	4PT-14291-10	.BRACKET 1	1	1	1	
13	4PT-14325-00	.SCREW, PAN HEAD	1	1	1	
14	5Y1-14384-00	.GASKET, FLOAT CHAMBER	1	1	1	
15	97601-04114	.SCREW, PAN HEAD WITH WASHER	6	6	6	
16	5Y1-14198-00	.GASKET	1	1	1	
17	5DS-1490K-00	.STOP SCREW SET	1	1	1	
18	5Y1-14159-00	.CLIP	2	2	2	
19	98901-04006	.SCREW, BIND	1	1	1	
20	5Y1-14536-00	.GASKET	1	1	1	
21	1KH-14371-01	.PLUNGER, STARTER	1	1	1	
22	5Y1-14146-00	.PLATE	1	1	1	
23	42U-14146-00	.PLATE	1	1	1	
24	1KH-14149-00	.PIPE	1	1	1	
25	1C6-14197-00	.PIPE	2	2	2	
26	1C6-14396-00	.PIPE	1	1	1	
27	14T-14323-00	.SCREW	1	1	1	

B10

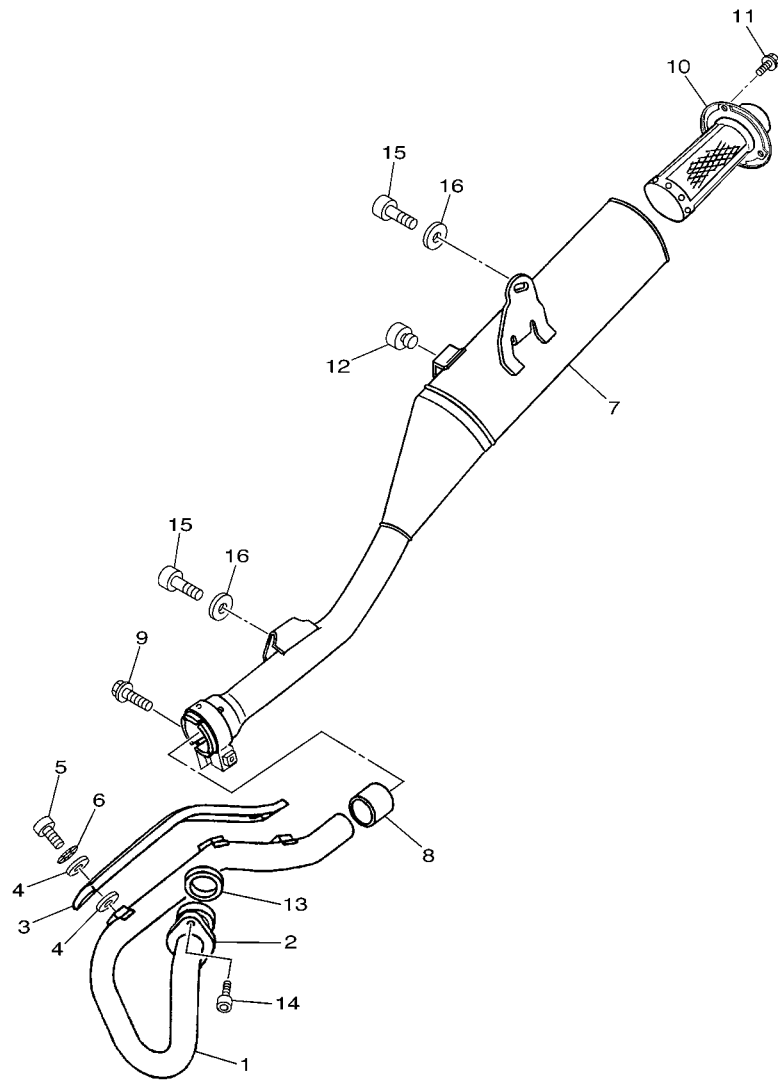

1C61100-D090

FIG. 9 EXHAUST

REF. NO.	PART NO.	DESCRIPTION	1C65	1C66	1C67	REMARKS
1	1C6-14611-00	PIPE, EXHAUST 1	1	1	1	
2	15A-14612-00	NUT, RING	1	1	1	
3	4VW-E4628-00	PROTECTOR, EXHAUST PIPE	1	1	1	
4	4BD-14766-00	WASHER, PROTECTOR	6	6	6	
5	9890M-06010	SCREW, BIND	3	3	3	
6	90206-06090	WASHER, WAVE	3	3	3	
7	1C6-E4711-00	MUFFLER 1	1	1	1	
8	3YF-14714-00	GASKET, MUFFLER	1	1	1	
9	9502M-08025	BOLT, FLANGE	1	1	1	
10	1C6-14780-00	SPARK ARRESTER ASSY	1	1	1	
11	9502L-06010	BOLT, FLANGE	3	3	3	
12	4FU-24181-00	DAMPER, LOCATING 1	1	1	1	
13	4BE-14613-00	GASKET, EXHAUST PIPE	1	1	1	
14	9131M-06020	BOLT	2	2	2	
15	90109-085E2	BOLT	2	2	2	
16	90201-08326	WASHER, PLATE	2	2	2	

FIG. 10 CRANKCASE

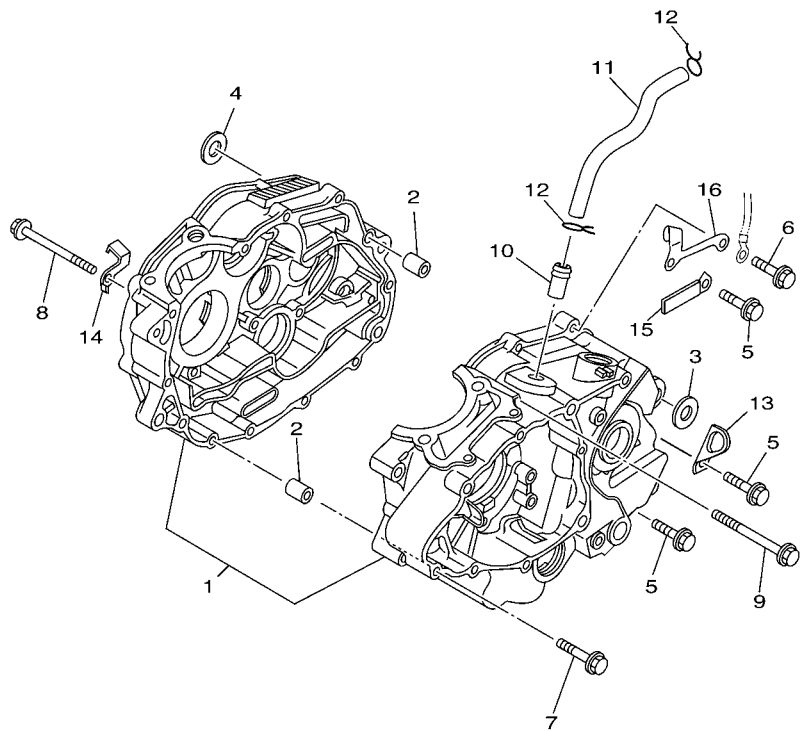

REF. NO.	PART NO.	DESCRIPTION	1C65	1C66	1C67	REMARKS
1	4VW-E5150-01	CRANKCASE ASSY	1	1	1	
2	99530-12016	PIN, DOWEL	2	2	2	
3	90387-125F1	COLLAR	1	1	1	
4	90387-125F1	COLLAR	1	1	1	
5	9502M-06030	BOLT, FLANGE	6	6	6	
6	90105-06830	BOLT, FLANGE	1	1	1	
7	9502M-06040	BOLT, FLANGE	2	2	2	
8	9502M-06090	BOLT, FLANGE	2	2	2	
9	9502M-06085	BOLT, FLANGE	1	1	1	
10	371-11167-01	PIPE, BREATHER 2	1	1	1	
11	1C6-E531A-00	HOSE, BREATHER 1	1	1	1	
12	90467-14015	CLIP	2	2	2	
13	90465-08200	CLAMP	1	1	1	
14	90462-08224	CLAMP	1	1	1	
15	90465-08127	CLAMP	1	1	1	
16	4JG-15441-02	HOLDER, CLUTCH CABLE	1	1	1	

1C61100-D100

FIG. 11 CRANKCASE COVER 1

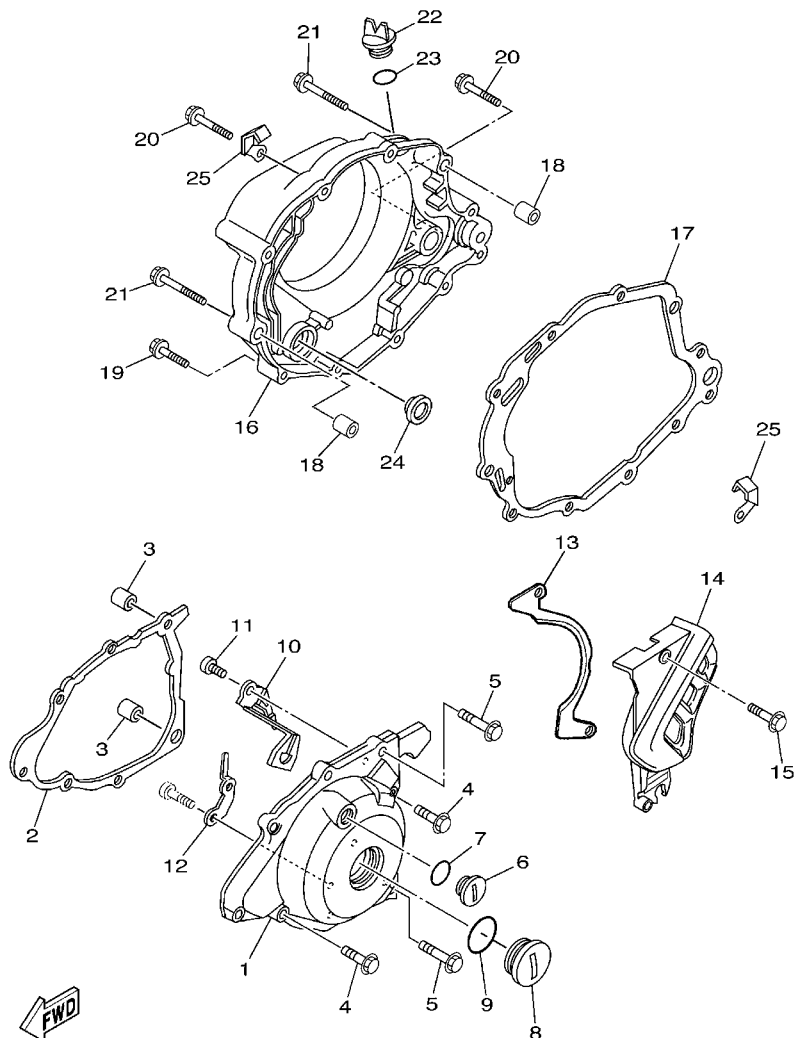

1C61100-D110

REF. NO.	PART NO.	DESCRIPTION	1C65	1C66	1C67	REMARKS
1	1C6-E5411-00-WN	COVER, CRANKCASE 1	1	1	1	CIS
2	4BE-15451-03	GASKET, CRANKCASE COVER 1	1	1	1	
3	99530-12016	PIN, DOWEL	2	2	2	
4	9502M-06025	BOLT, FLANGE	5	5	5	
5	9502M-06035	BOLT, FLANGE	3	3	3	
6	90340-14128	PLUG, STRAIGHT SCREW	1	1	1	
7	93210-14800	O-RING	1	1	1	
8	90340-32123	PLUG, STRAIGHT SCREW	1	1	1	
9	93210-32800	O-RING	1	1	1	
10	1C6-E5758-00	GUIDE, ROPE	1	1	1	
11	9201M-06010	BOLT, BUTTON HEAD	1	1	1	
12	1C6-E5484-00	CLAMP 2	1	1	1	
13	1C6-E7466-00	GUIDE, CHAIN	1	1	1	
14	1C6-E5420-00-WN	CRANKCASE COVER ASSY 2	1	1	1	CIS
15	9502M-06025	BOLT, FLANGE	2	2	2	
16	4VW-WE543-00	CRANKCASE COVER ASSY 2	1	1	1	
17	4BE-15462-00	GASKET, CRANKCASE COVER 3	1	1	1	
18	99530-12016	PIN, DOWEL	2	2	2	
19	9502M-06025	BOLT, FLANGE	5	5	5	
20	9502M-06035	BOLT, FLANGE	3	3	3	
21	9502M-06045	BOLT, FLANGE	2	2	2	
22	3Y1-15363-00	PLUG, OIL	1	1	1	
23	93210-19123	O-RING	1	1	1	
24	3Y1-15361-00	GAUGE, LEVEL	1	1	1	
25	90462-08225	CLAMP	2	2	2	

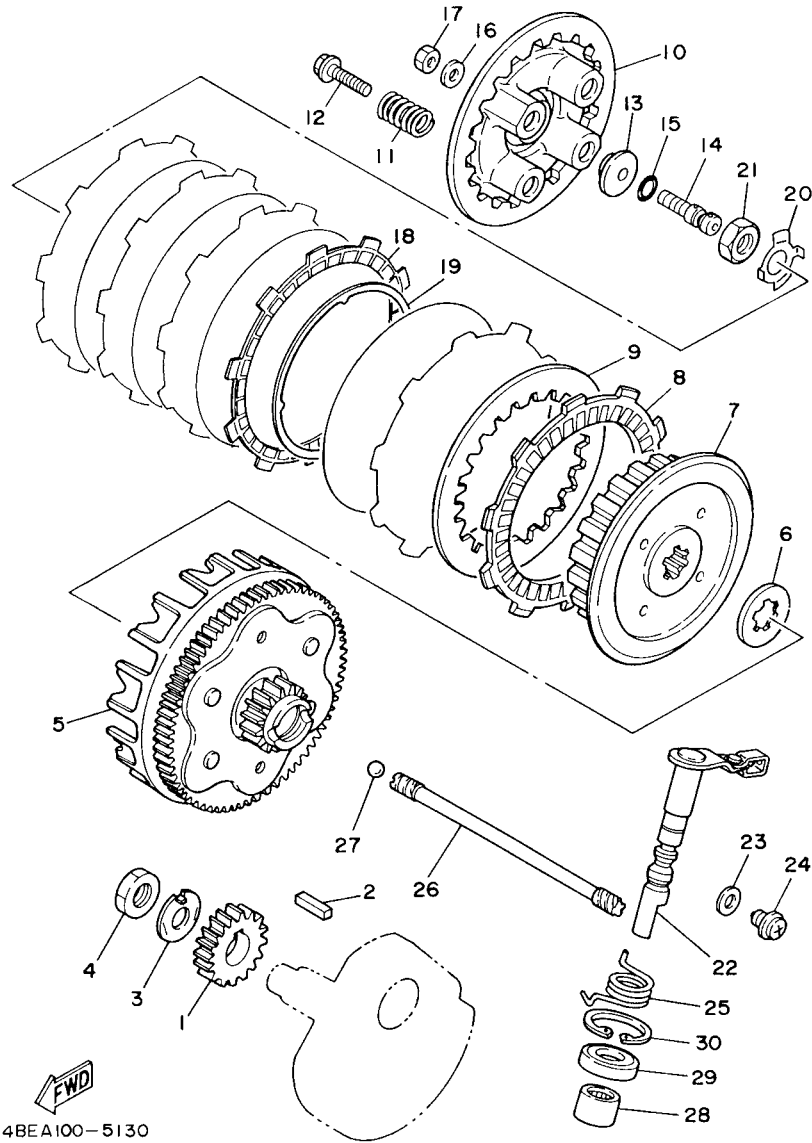
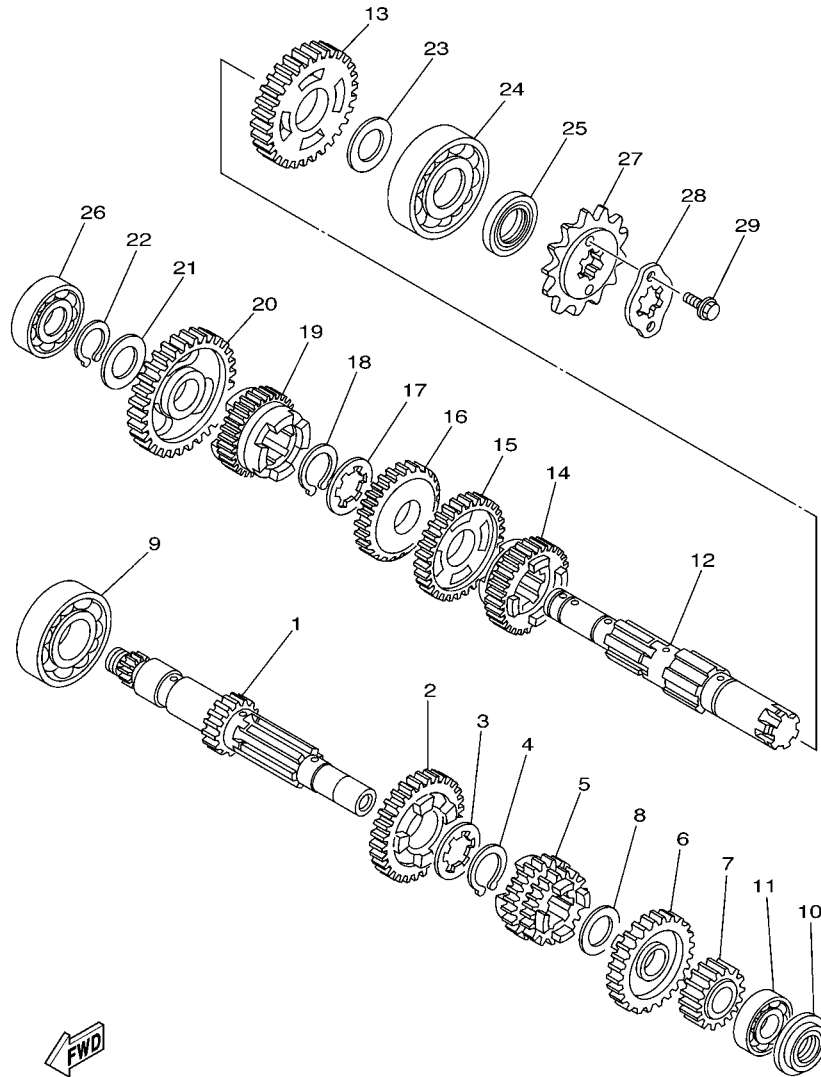

FIG. 13 CLUTCH

REF. NO.	PART NO.	DESCRIPTION	1C65	1C66	1C67	REMARKS
1	5H0-16111-00	GEAR, PRIMARY DRIVE (22T)	1	1	1	
2	90282-05043	KEY, STRAIGHT	1	1	1	
3	90215-14205	WASHER, LOCK	1	1	1	
4	90170-14284	NUT	1	1	1	
5	1KH-16150-00	PRIMARY DRIVEN GEAR COMP.	1	1	1	
6	2LN-16154-00	PLATE, THRUST 1	1	1	1	
7	2LN-16371-00	BOSS, CLUTCH	1	1	1	
8	537-16321-00	PLATE, FRICTION	5	5	5	
9	137-16324-00	PLATE, CLUTCH 1	5	5	5	
10	5H0-16351-00	PLATE, PRESSURE 1	1	1	1	
11	90501-23700	SPRING, COMPRESSION	4	4	4	
12	90159-05011	SCREW, WITH WASHER	4	4	4	
13	1W1-16358-01	PLATE, PUSH	1	1	1	
14	4JG-16356-00	ROD, PUSH 1	1	1	1	
15	93210-48364	O-RING	1	1	1	
16	92907-06200	WASHER	1	1	1	
17	95307-06600	NUT	1	1	1	
18	36X-16321-00	PLATE, FRICTION	1	1	1	
19	1KH-16383-00	SPRING, CLUTCH BOSS	1	1	1	
20	90215-14186	WASHER, LOCK	1	1	1	
21	90170-14284	NUT	1	1	1	
22	4JG-16380-01	PUSH LEVER ASSY	1	1	1	
23	90430-08119	GASKET	1	1	1	
24	90149-08067	SCREW	1	1	1	
25	90508-18495	SPRING, TORSION	1	1	1	
26	5H0-16357-00	ROD, PUSH 2	1	1	1	
27	93505-16006	BALL	1	1	1	

FIG. 14 TRANSMISSION



1C61100-D140

REF. NO.	PART NO.	DESCRIPTION	1C65	1C66	1C67	REMARKS
1	1C6-E7411-00	AXLE, MAIN (13T)	1	1	1	
2	5MP-17161-00	GEAR, 6TH PINION (29T)	1	1	1	
3	90209-17285	WASHER	1	1	1	
4	93410-20038	CIRCLIP	1	1	1	
5	1KH-17131-01	GEAR, 3RD/4TH PINION (21T/24T)	1	1	1	
6	5MP-17151-00	GEAR, 5TH PINION (27T)	1	1	1	
7	17T-17121-00	GEAR, 2ND PINION (18T)	1	1	1	
8	90201-164K2	WASHER, PLATE	1	1	1	
9	93306-20401	BEARING	1	1	1	
10	93101-15101	OIL SEAL	1	1	1	
11	93306-20201	BEARING	1	1	1	
12	1C6-E7402-00	DRIVE AXLE ASSY	1	1	1	
13	17T-17221-01	GEAR, 2ND WHEEL (34T)	1	1	1	
14	5MP-17251-00	GEAR, 5TH WHEEL (25T)	1	1	1	
15	4VW-E7231-01	GEAR, 3RD WHEEL (30T)	1	1	1	
16	17T-17241-03	GEAR, 4TH WHEEL (27T)	1	1	1	
17	90209-18208	WASHER	1	1	1	
18	93410-22039	CIRCLIP	1	1	1	
19	5MP-17261-00	GEAR, 6TH WHEEL (23T)	1	1	1	
20	5BT-17211-00	GEAR, 1ST WHEEL (38T)	1	1	1	
21	90201-17257	WASHER, PLATE	1	1	1	
22	99009-17400	CIRCLIP	1	1	1	
23	90201-203E7	WASHER, PLATE	1	1	1	
24	93306-30424	BEARING	1	1	1	
25	93102-20004	OIL SEAL	1	1	1	
26	93306-20332	BEARING	1	1	1	
27	93832-13164	SPROCKET, DRIVE (13T)	1	1	1	

FIG. 14 TRANSMISSION

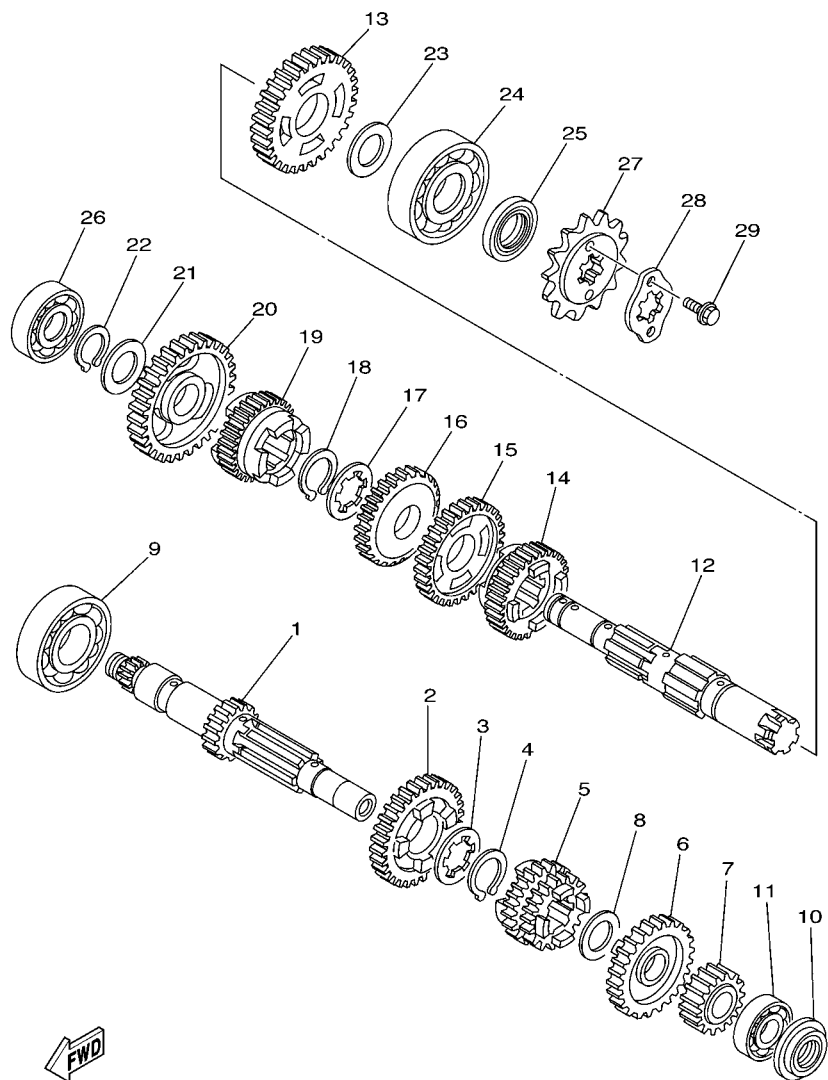

1C61100-D140

REF. NO.	PART NO.	DESCRIPTION	1C65	1C66	1C67	REMARKS
28	4AN-E7456-00	HOLDER, SPROCKET	1	1	1	
29	9702M-06010	BOLT	2	2	2	

FIG. 15 SHIFT CAM & FORK

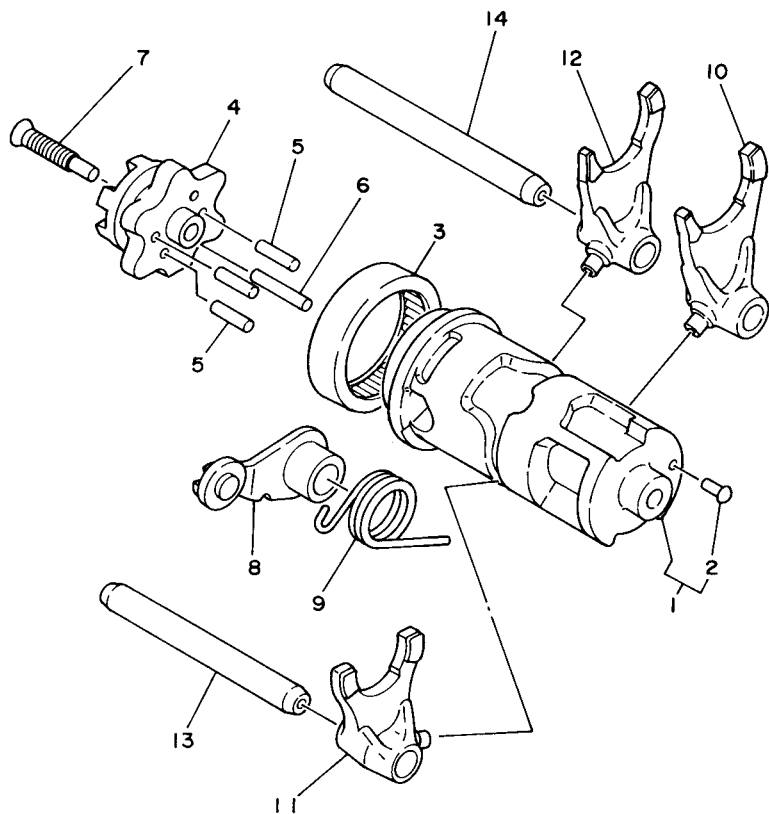

REF. NO.	PART NO.	DESCRIPTION	1C65	1C66	1C67	REMARKS
1	4JG-18540-00	SHIFT CAM ASSY	1	1	1	
2	136-18542-00	.POINT, NEUTRAL	1	1	1	
3	93315-23607	BEARING	1	1	1	
4	4JG-18185-00	SEGMENT	1	1	1	
5	93604-16092	PIN, DOWEL	4	4	4	
6	93604-20156	PIN, DOWEL	1	1	1	
7	90151-06013	SCREW, COUNTERSUNK	1	1	1	
8	1RH-18140-00	STOPPER LEVER ASSY	1	1	1	
9	90508-26539	SPRING, TORSION	1	1	1	
10	4JG-18513-00	FORK, SHIFT 3	1	1	1	
11	4JG-18511-00	FORK, SHIFT 1	1	1	1	
12	4JG-18512-01	FORK, SHIFT 2	1	1	1	
13	3GX-18531-00	BAR, SHIFT FORK GUIDE 1	1	1	1	
14	3GX-18535-00	BAR, SHIFT FORK GUIDE 2	1	1	1	

FWD
25A310-3161

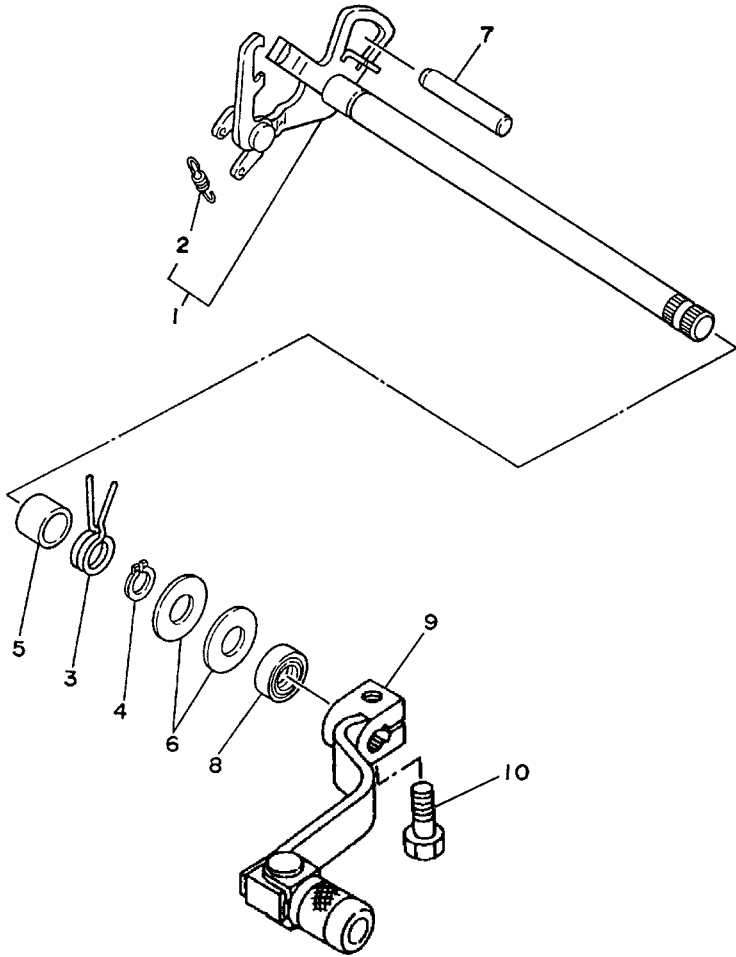

1C61100-D160

FIG. 16 SHIFTER

REF. NO.	PART NO.	DESCRIPTION	1C65	1C66	1C67	REMARKS
1	5H0-18120-02	SHIFT LEVER ASSY	1	1	1	
2	90506-08227	.SPRING, TENSION	1	1	1	
3	90508-26705	SPRING, TORSION	1	1	1	
4	99001-10600	CIRCLIP	1	1	1	
5	90387-124F4	COLLAR	1	1	1	
6	90201-12588	WASHER, PLATE	2	2	2	
7	93608-50158	PIN, DOWEL	1	1	1	
8	93102-12106	OIL SEAL (SD 12-22-5 HS)	1	1	1	
9	1C6-E8110-00	SHIFT PEDAL ASSY	1	1	1	
10	9702M-06020	BOLT	1	1	1	

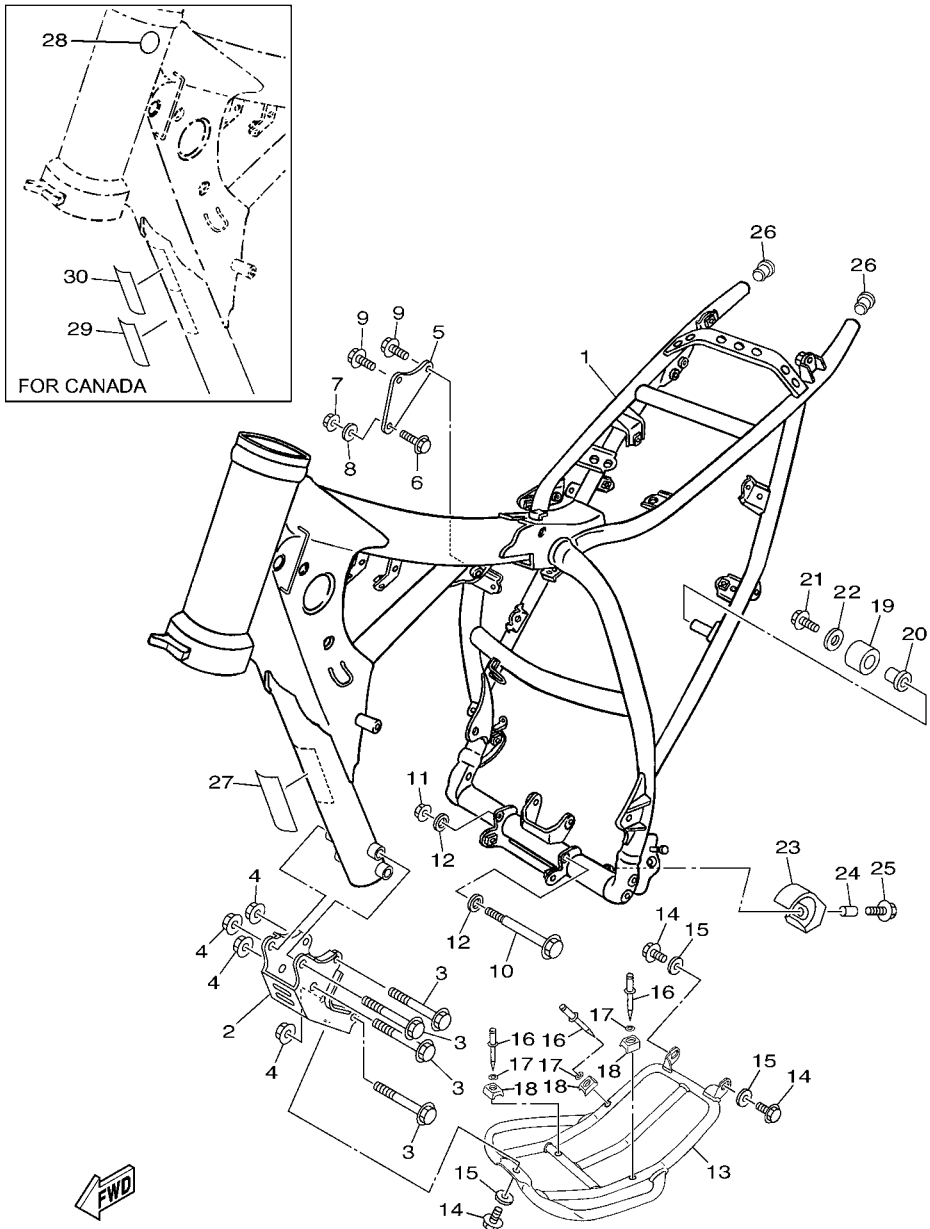

1C65100-E171

FIG. 17 FRAME

REF. NO.	PART NO.	DESCRIPTION	1C65	1C66	1C67	REMARKS
1	1C6-F1110-00	FRAME COMP.	1	1	1	
2	1C6-F1316-00	STAY, ENGINE 3	1	1	1	
3	90105-08852	BOLT, FLANGE	4	4	4	
4	95607-08200	NUT, SELF-LOCKING	4	4	4	
5	1C6-F1315-00	STAY, ENGINE 2	1	1	1	
6	9581M-08055	BOLT, FLANGE	1	1	1	
7	95607-08200	NUT, SELF-LOCKING	1	1	1	
8	90201-09801	WASHER, PLATE	1	1	1	
9	90105-08846	BOLT, FLANGE	2	2	2	
10	90105-08856	BOLT, FLANGE	1	1	1	
11	95607-08200	NUT, SELF-LOCKING	1	1	1	
12	90201-09801	WASHER, PLATE	2	2	2	
13	1C6-F1471-00	PROTECTOR, ENGINE	1	1	1	
14	9581M-10020	BOLT, FLANGE	3	3	3	
15	90201-101J1	WASHER, PLATE	3	3	3	
16	90267-40802	RIVET, BLIND	3	3	3	
17	90201-042E0	WASHER, PLATE	3	3	3	
18	1C6-F1485-00	DAMPER, RUBBER 1	3	3	3	
19	5RM-F2178-00	TENSIONER	1	1	1	
20	5RM-F2184-00	BUSH	1	1	1	
21	9502M-08012	BOLT, FLANGE	1	1	1	
22	90201-08753	WASHER, PLATE	1	1	1	
23	1B2-F2178-00	TENSIONER	1	1	1	
24	90387-060A3	COLLAR	1	1	1	
25	90119-06118	BOLT, WITH WASHER	1	1	1	
26	90338-16148	PLUG	2	2	2	
27	1C6-2179C-00	PLATE, EPA	1			

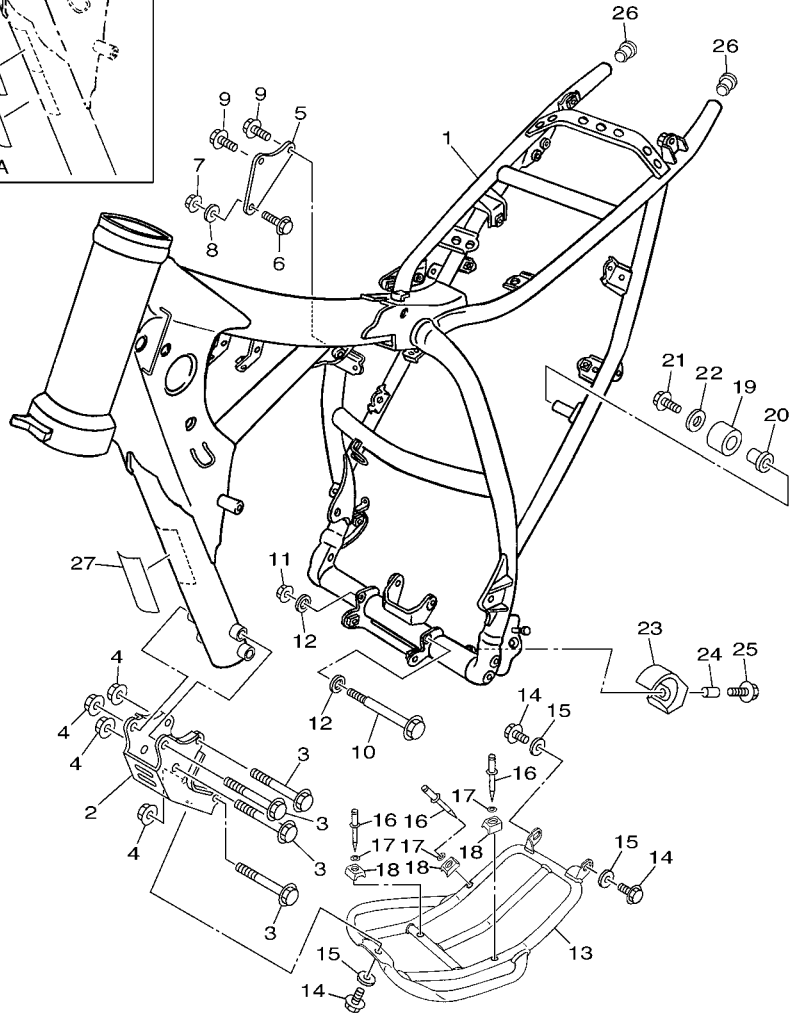
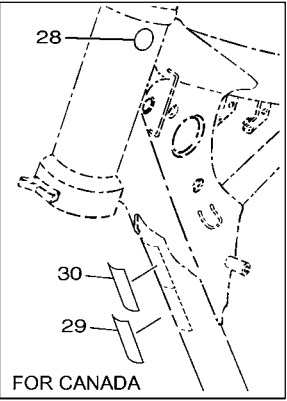

1C65100-E171

FIG. 17 FRAME

REF. NO.	PART NO.	DESCRIPTION	1C65	1C66	1C67	REMARKS
28	278-21183-01	PLATE		1		FOR CANADA
29	3JK-82377-00	LABEL		1		
30	3PT-2416E-10	LABEL, CAUTION CANADA		1		

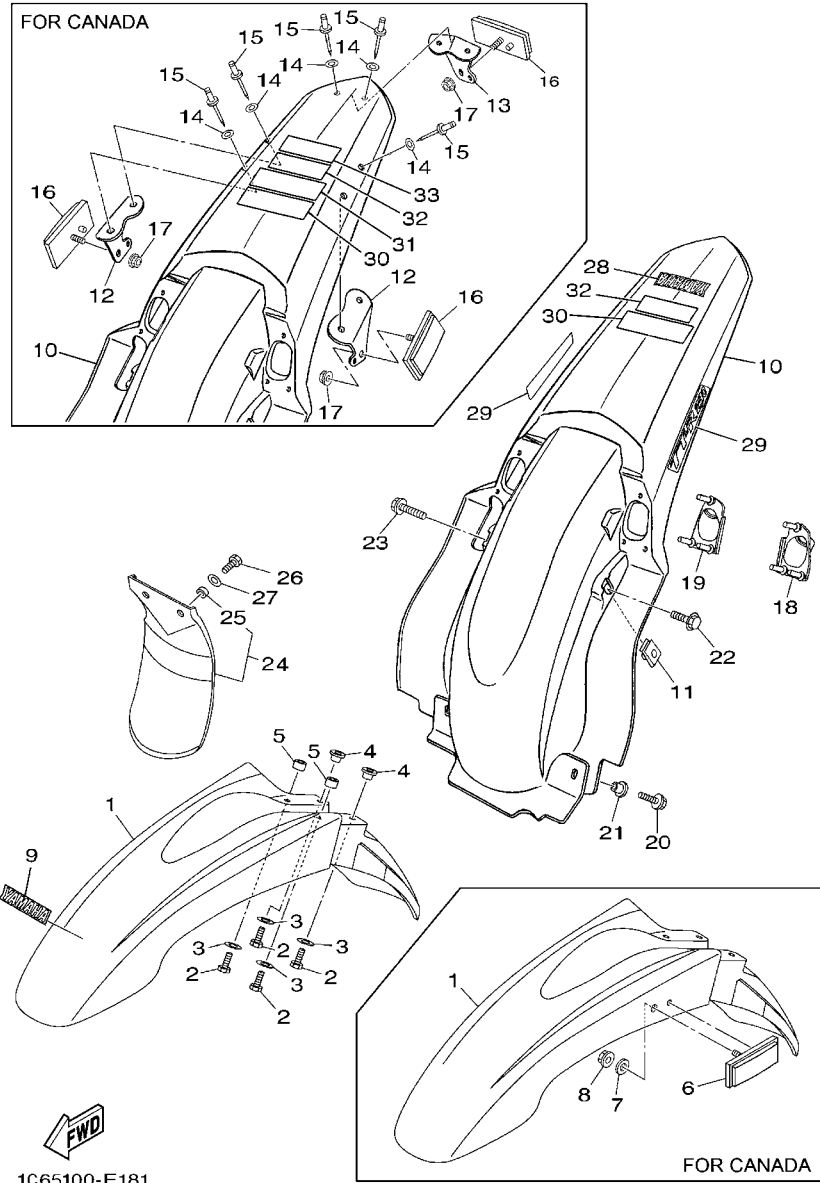

1C65100-E181

FIG. 18 FENDER

REF. NO.	PART NO.	DESCRIPTION	1C65	1C66	1C67	REMARKS
1	5RM-F1511-00	FENDER, FRONT	1		1	
	1C6-F1511-00	FENDER, FRONT		1		
2	9700M-06020	BOLT	4	4	4	
3	90201-06804	WASHER, PLATE	4	4	4	
4	90387-061V4	COLLAR	2	2	2	
5	90387-06023	COLLAR	2	2	2	
6	11H-85110-01	REFLECTOR ASSY		2		
7	90201-05W39	WASHER, PLATE		2		
8	9570M-05500	NUT, FLANGE		2		
9	1B2-F153E-00	EMBLEM, YAMAHA	1	1	1	
10	1C6-F1611-00	FENDER, REAR	1		1	
	1C6-F1611-10	FENDER, REAR		1		
11	1C6-F1635-00	NUT, REAR FENDER	2	2	2	
12	1C6-F164F-00	STAY 1		2		
13	1C6-F164G-00	STAY 2		1		
14	90201-04018	WASHER, PLATE		6		
15	90267-40804	RIVET, BLIND		6		
16	3Y6-85130-02	REAR REFLECTOR ASSY		3		
17	9570M-05500	NUT, FLANGE		3		
18	1C6-F163A-00	COVER, REAR FENDER 1	1	1	1	
19	1C6-F163E-00	COVER, REAR FENDER 2	1	1	1	
20	9580M-06012	BOLT, FLANGE	2	2	2	
21	90387-06681	COLLAR	2	2	2	
22	9580M-06012	BOLT, FLANGE	1	1	1	
23	9582M-06030	BOLT, FLANGE	1	1	1	
24	5RM-F1642-00	GUARD, FLAP	1	1	1	
25	90387-060T4	.COLLAR	2	2	2	

FIG. 18 FENDER

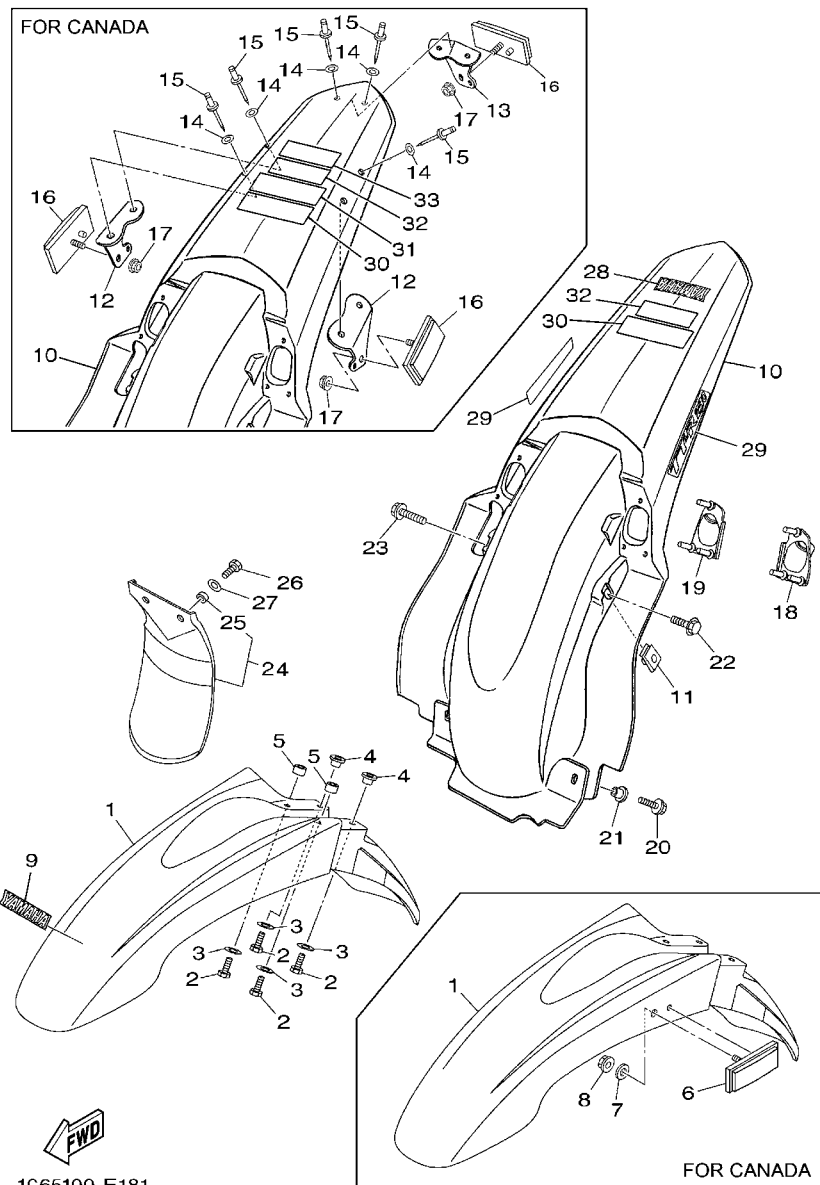

1C65100-E181

REF. NO.	PART NO.	DESCRIPTION	1C65	1C66	1C67	REMARKS
26	9700M-06016	BOLT	2	2	2	
27	90201-06804	WASHER, PLATE	2	2	2	
28	1B2-F153E-00	EMBLEM, YAMAHA	1	1	1	
29	1C6-F163G-10	EMBLEM 1	2	2	2	
30	3PT-2118K-A0	LABEL, CAUTION	1	1		
	5PA-21568-00	LABEL, WARNING			1	
31	3PT-2118K-B0	LABEL, CAUTION		1		
32	3XJ-2151H-A1	LABEL 5	1	1		
33	3XJ-2151H-B1	LABEL 5		1		

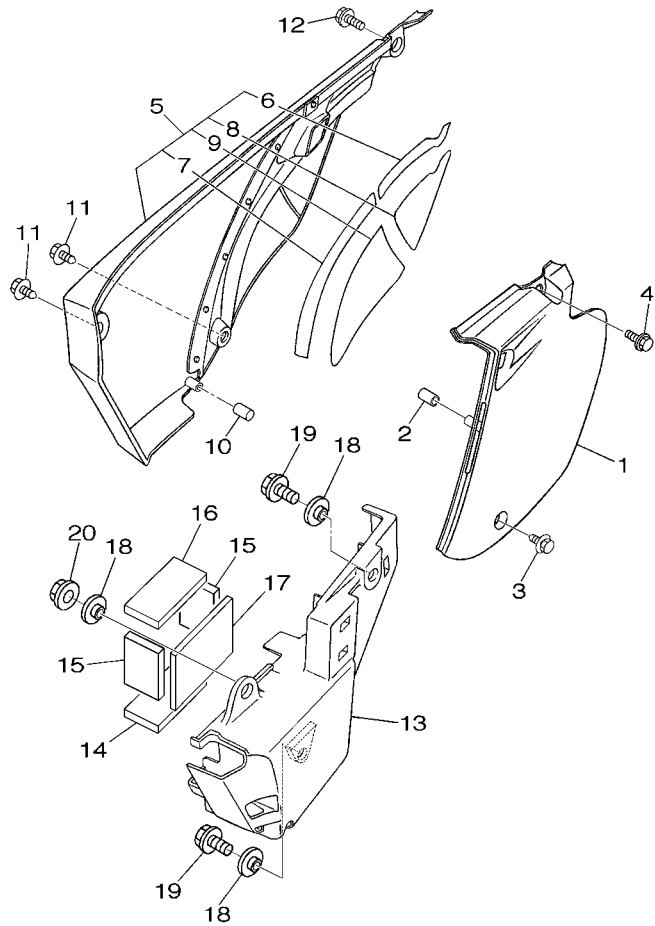

1C61100-D190

FIG. 19 SIDE COVER

REF. NO.	PART NO.	DESCRIPTION	1C65	1C66	1C67	REMARKS
1	1C6-F1711-00	COVER, SIDE 1	1	1	1	
2	1C6-F1778-00	DAMPER, LOCATING 1	1	1	1	
3	90119-06018	BOLT, WITH WASHER	1	1	1	
4	90119-08238	BOLT, WITH WASHER	1	1	1	
5	1C6-F1720-00	SIDE COVER ASSY 2	1	1	1	
6	1C6-F174A-00	.INSULATOR, SIDE COVER	1	1	1	
7	1C6-F174T-00	.INSULATOR, SIDE COVER 2	1	1	1	
8	1C6-F173M-00	.SEAL 3	1	1	1	
9	1C6-F173N-00	.SEAL 4	1	1	1	
10	1C6-F1778-00	DAMPER, LOCATING 1	1	1	1	
11	90119-06018	BOLT, WITH WASHER	2	2	2	
12	90119-08238	BOLT, WITH WASHER	1	1	1	
13	1C6-F177G-00	BOX, BATTERY	1	1	1	
14	1C6-F1746-00	DAMPER	1	1	1	
15	1C6-F1747-00	DAMPER	2	2	2	
16	1C6-F174X-00	DAMPER	1	1	1	
17	1C6-F174Y-00	DAMPER	1	1	1	
18	90387-06681	COLLAR	3	3	3	
19	9582M-06016	BOLT, FLANGE	2	2	2	
20	9570M-06500	NUT, FLANGE	1	1	1	

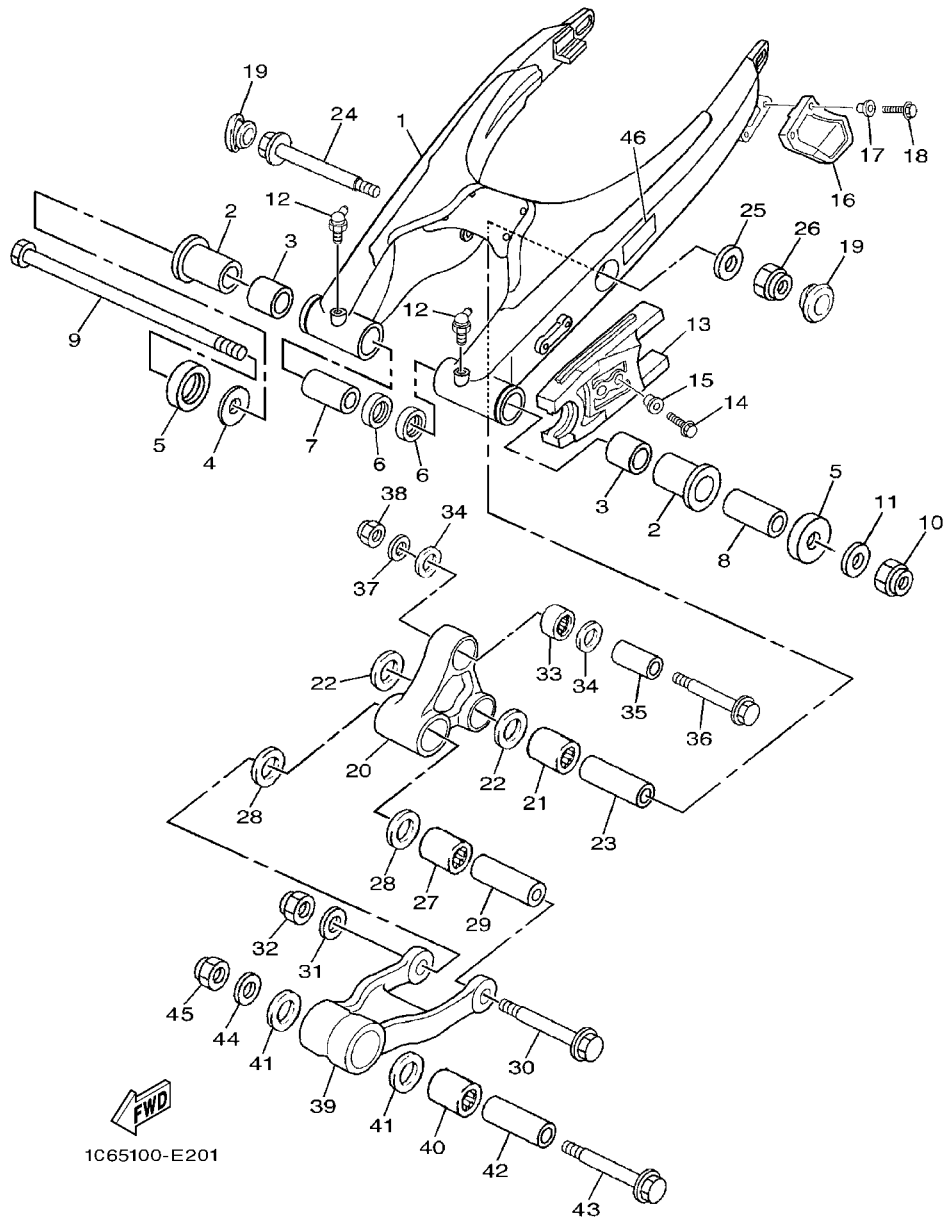

1C65100-E201

FIG. 20 REAR ARM

REF. NO.	PART NO.	DESCRIPTION	1C65	1C66	1C67	REMARKS
1	1C6-F2110-00-35	REAR ARM COMP.	1	1	1	SL
2	90386-18146	BUSH	2	2	2	
3	90380-18139	BUSH, SOLID	2	2	2	
4	5L9-F2127-00	SHIM	1	1	1	UN
5	5L9-F2128-00	COVER, THRUST 1	2	2	2	
6	93109-18020	OIL SEAL	2	2	2	
7	90387-121N2	COLLAR	1	1	1	
8	90387-127F2	COLLAR	1	1	1	
9	1C6-F2141-00	SHAFT, PIVOT	1	1	1	
10	90185-12134	NUT, SELF-LOCKING	1	1	1	
11	90201-126A7	WASHER, PLATE	1	1	1	
12	93700-06803	NIPPLE, GREASE	2	2	2	
13	1B2-F2151-10	SEAL, GUARD	1	1	1	
14	9700M-06016	BOLT	2	2	2	
15	90387-062X0	COLLAR	2	2	2	
16	5RM-F2199-00	SUPPORT, CHAIN	1	1	1	
17	90387-06737	COLLAR	2	2	2	
18	9700M-06016	BOLT	2	2	2	
19	1C6-F2117-00	CAP	2	2	2	
20	1C6-2217A-00	ARM, RELAY	1	1	1	
21	93315-32056	BEARING	1	1	1	
22	93109-20076	OIL SEAL	2	2	2	
23	90387-14007	COLLAR	1	1	1	
24	90105-12801	BOLT, FLANGE	1	1	1	
25	90201-126A7	WASHER, PLATE	1	1	1	
26	95617-12100	NUT, U	1	1	1	
27	93315-32056	BEARING	1	1	1	

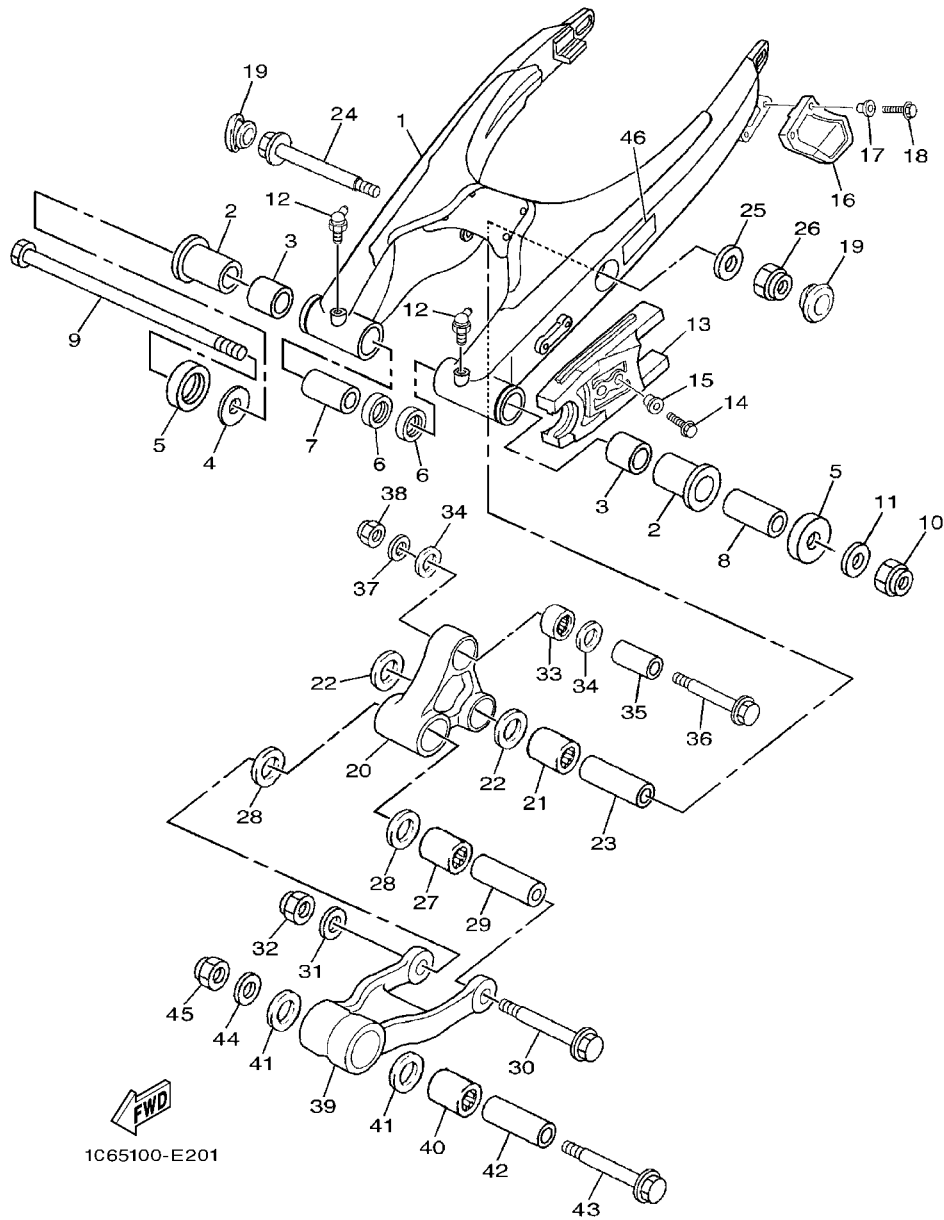

1C65100-E201

FIG. 20 REAR ARM

REF. NO.	PART NO.	DESCRIPTION	1C65	1C66	1C67	REMARKS
28	93109-20076	OIL SEAL	2	2	2	
29	90387-12024	COLLAR	1	1	1	
30	90105-12800	BOLT, FLANGE	1	1	1	
31	90201-126A7	WASHER, PLATE	1	1	1	
32	95617-12100	NUT, U	1	1	1	
33	93315-31758	BEARING	1	1	1	
34	93109-17071	OIL SEAL	2	2	2	
35	90387-1012A	COLLAR	1	1	1	
36	90105-10818	BOLT, FLANGE	1	1	1	
37	90201-101J1	WASHER, PLATE	1	1	1	
38	95617-10100	NUT, U	1	1	1	
39	1C6-F217F-00	ROD, CONNECTING 1	1	1	1	
40	93315-32056	BEARING	1	1	1	
41	93109-20076	OIL SEAL	2	2	2	
42	90387-12023	COLLAR	1	1	1	
43	90101-12804	BOLT	1	1	1	
44	90201-126A7	WASHER, PLATE	1	1	1	
45	95617-12100	NUT, U	1	1	1	
46	3RV-21668-A0	LABEL, TIRE	1	1	1	

FIG. 22 STEERING

REF. NO.	PART NO.	DESCRIPTION	1C65	1C66	1C67	REMARKS
1	93332-00008	BEARING	1	1	1	
2	93332-00001	BEARING	1	1	1	
3	4JG-23416-00	COVER, BALL RACE 2	1	1	1	
4	90179-25W23	NUT	1	1	1	
5	90202-26142	WASHER, PLATE	1	1	1	
6	90179-25W22	NUT	1	1	1	
7	5HH-F3418-00	WASHER, SPECIAL	1	1	1	
8	1C6-F3435-00	CROWN, HANDLE	1	1	1	
9	90179-22412	NUT	1	1	1	
10	1C6-F319U-00	CAP	1	1	1	
11	9502M-08040	BOLT, FLANGE	4	4	4	
12	3V9-F3441-10	HOLDER, HANDLE UPPER	2	2	2	
13	9502M-08035	BOLT, FLANGE	4	4	4	
14	1C6-F3485-00	PLATE, NUMBER	1	1	1	
15	90387-064J1	.COLLAR	1	1	1	
16	9502M-06014	BOLT, FLANGE	1	1	1	
17	1C6-F3486-00	STAY, PLATE	1	1	1	
18	90480-13428	GROMMET	2	2	2	
19	90465-14242	CLAMP	2	2	2	
20	9131M-06016	BOLT	2	2	2	
21	3RV-21668-B0	LABEL, TIRE		1		
22	1C6-H350E-00	BRACKET	1	1	1	
23	9580M-06014	BOLT, FLANGE	2	2	2	

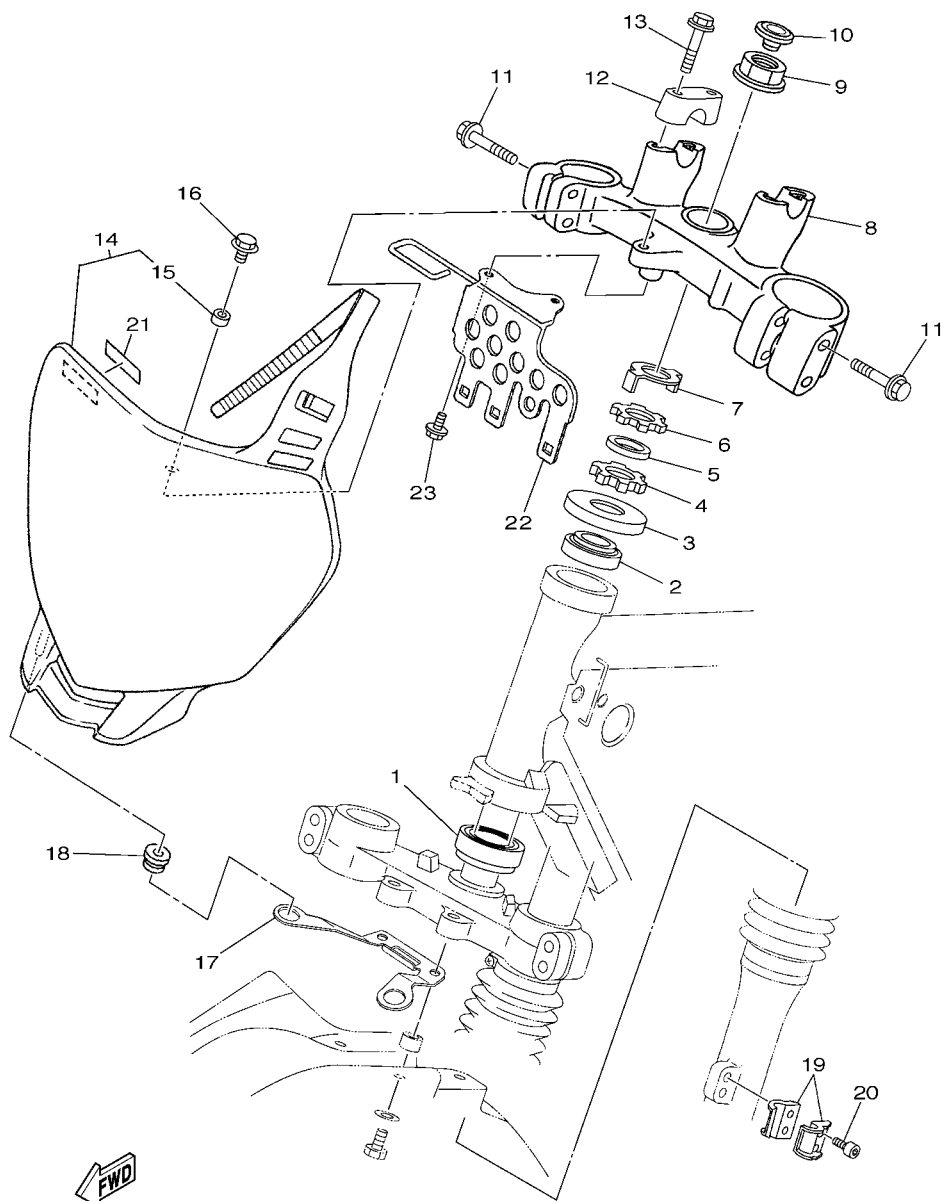

1C65100-E220

FIG. 23 FRONT FORK

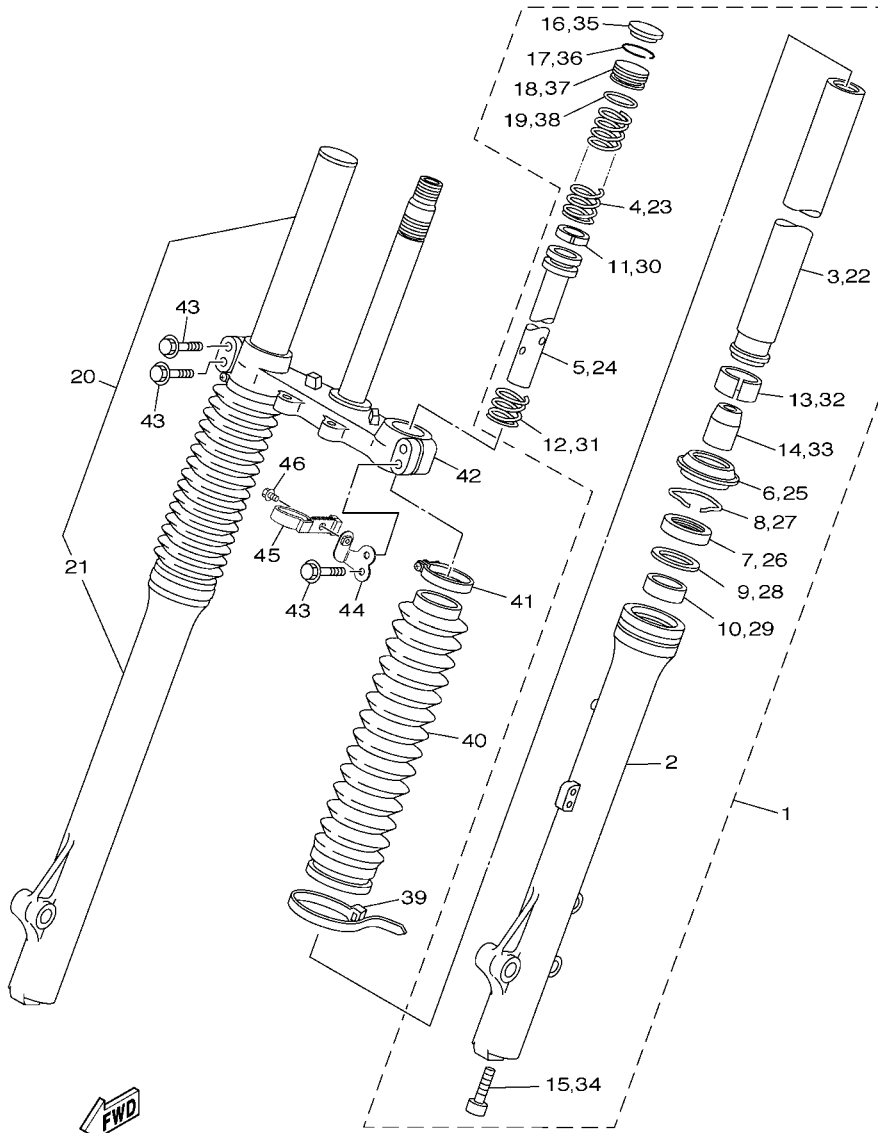

1C61100-D230

REF. NO.	PART NO.	DESCRIPTION	1C65	1C66	1C67	REMARKS
1	1C6-F3102-00	.FRONT FORK ASSY (L.H)	1	1	1	
2	1C6-F3126-00	.TUBE, OUTER (LEFT)	1	1	1	
3	1C6-F3110-00	.INNER TUBE COMP.1	1	1	1	
4	1C6-F3351-00	.SPRING	1	1	1	
5	1C6-F3171-00	.PISTON, FRONT FORK	1	1	1	
6	1KH-23144-00	.SEAL, DUST	1	1	1	
7	1KH-23145-00	.OIL SEAL	1	1	1	
8	34X-23156-00	.CLIP, OIL SEAL	1	1	1	
9	1KH-23147-00	.SEAL, SPACER	1	1	1	
10	34X-23125-00	.METAL, SLIDE 1	1	1	1	
11	34X-23157-00	.RING, PISTON	1	1	1	
12	34X-23151-00	.SPRING, REBOUND	1	1	1	
13	34X-23135-00	.METAL, SLIDE 2	1	1	1	
14	4AN-F3166-00	.SPACER, OIL LOCK	1	1	1	
15	3M7-23181-00	.BOLT, HEXAGON SOCKET HEAD	1	1	1	WITH WASHER
16	35E-23168-00	.CAP, FRONT FORK	1	1	1	
17	35E-23183-00	.CIRCLIP	1	1	1	
18	4AN-F3111-00	.BOLT, CAP	1	1	1	
19	4AN-F3114-00	.GASKET	1	1	1	
20	1C6-F3103-00	.FRONT FORK ASSY (R.H)	1	1	1	
21	1C6-F3136-00	.TUBE, OUTER (RIGHT)	1	1	1	
22	1C6-F3110-00	.INNER TUBE COMP.1	1	1	1	
23	1C6-F3351-00	.SPRING	1	1	1	
24	1C6-F3171-00	.PISTON, FRONT FORK	1	1	1	
25	1KH-23144-00	.SEAL, DUST	1	1	1	
26	1KH-23145-00	.OIL SEAL	1	1	1	
27	34X-23156-00	.CLIP, OIL SEAL	1	1	1	

FIG. 23 FRONT FORK

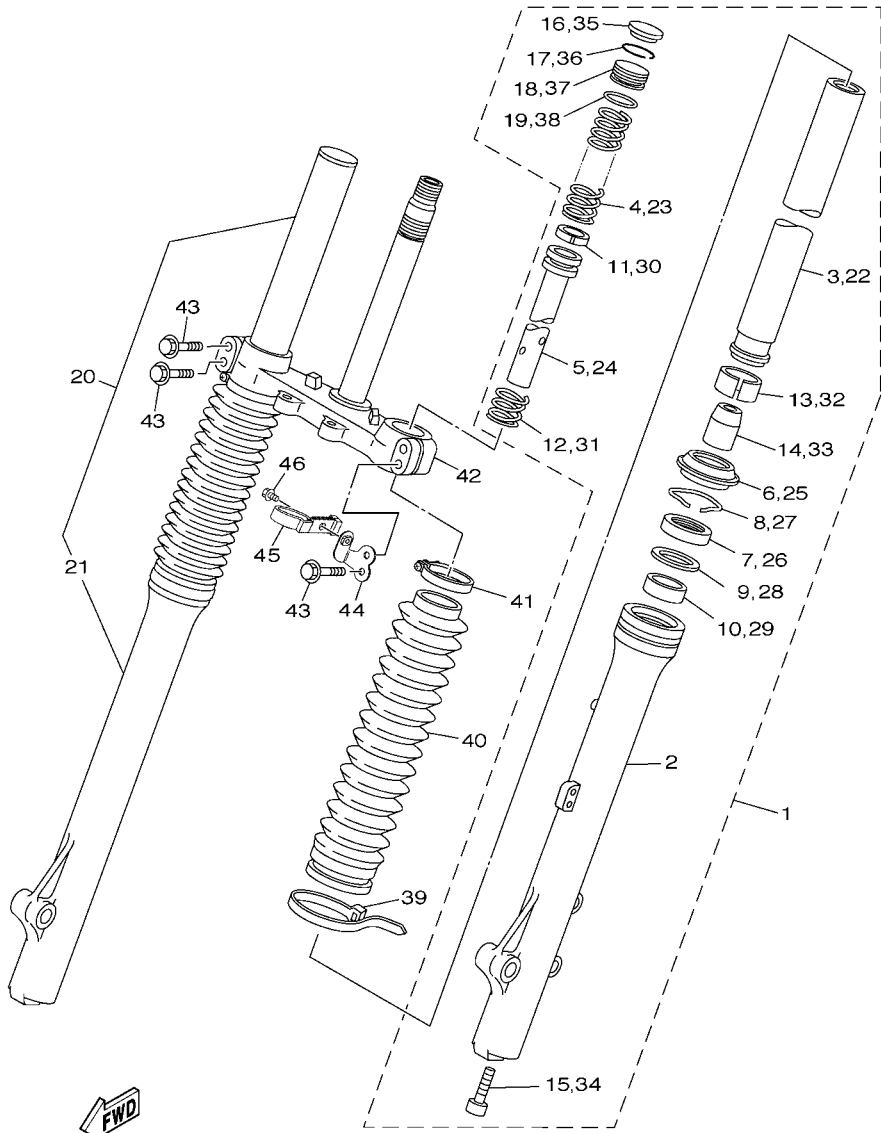

1C61100-D230

REF. NO.	PART NO.	DESCRIPTION	1C65	1C66	1C67	REMARKS
28	1KH-23147-00	.SEAL, SPACER	1	1	1	
29	34X-23125-00	.METAL, SLIDE 1	1	1	1	
30	34X-23157-00	.RING, PISTON	1	1	1	
31	34X-23151-00	.SPRING, REBOUND	1	1	1	
32	34X-23135-00	.METAL, SLIDE 2	1	1	1	
33	4AN-F3166-00	.SPACER, OIL LOCK	1	1	1	
34	3M7-23181-00	.BOLT, HEXAGON SOCKET HEAD	1	1	1	WITH WASHER
35	35E-23168-00	.CAP, FRONT FORK	1	1	1	
36	35E-23183-00	.CIRCLIP	1	1	1	
37	4AN-F3111-00	.BOLT, CAP	1	1	1	
38	4AN-F3114-00	.GASKET	1	1	1	
39	4AN-F3192-10	BAND	2	2	2	
40	1C6-23191-00	BOOT	2	2	2	
41	4AN-F3192-00	BAND	2	2	2	
42	1C6-F3340-00	UNDER BRACKET COMP.	1	1	1	
43	4AN-F3346-00	BOLT 1	4	4	4	
44	1C6-F331E-00	GUIDE, CABLE	1	1	1	
45	1C6-F3389-00	GUIDE, CABLE	1	1	1	
46	90105-05361	BOLT, FLANGE	1	1	1	

FIG. 24 FUEL TANK

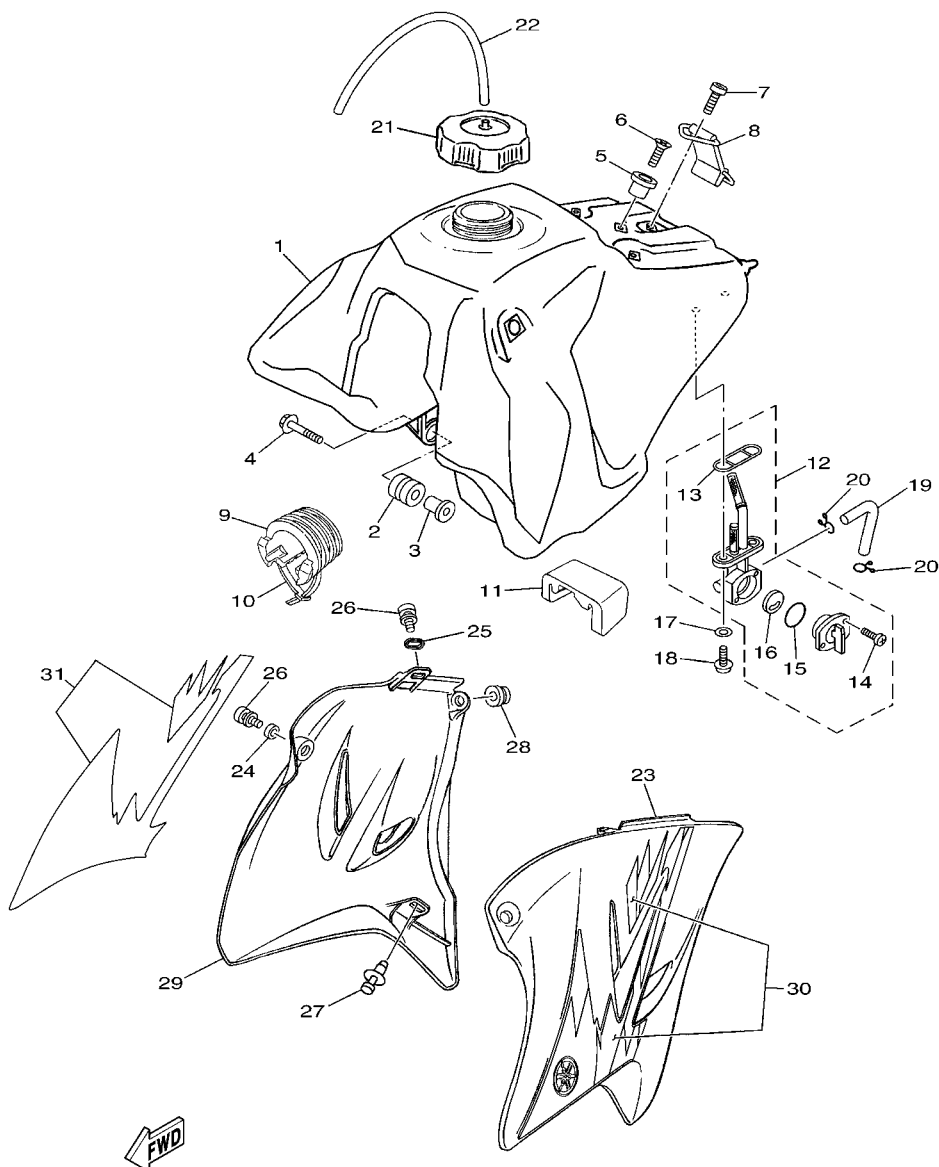

FWD
1C65100-E240

REF. NO.	PART NO.	DESCRIPTION	1C65	1C66	1C67	REMARKS
1	1C6-24110-00	FUEL TANK COMP.	1	1	1	
2	90480-18549	GROMMET	2	2	2	
3	1B2-F4186-00	WASHER, SPECIAL	2	2	2	
4	5XE-24176-00	BOLT 1	2	2	2	
5	1B2-F412F-00	BRACKET, SEAT	1	1	1	
6	9870M-06025	SCREW, FLAT HEAD	1	1	1	
7	9890M-06016	SCREW, BIND	1	1	1	
8	1C6-F4173-00	BAND, TANK FITTING 1	1	1	1	
9	1C6-F4181-00	DAMPER, LOCATING 1	1	1	1	
10	90465-13275	CLAMP	1	1	1	
11	1C6-F4182-00	DAMPER, LOCATING 2	1	1	1	
12	1C6-24500-01	FUEL COCK ASSY 1	1	1	1	
13	4X8-24512-00	.O-RING	1	1	1	
14	98517-03008	.SCREW, PAN HEAD	2	2	2	
15	3AJ-24534-01	.SEAL, COCK	1	1	1	
16	3AC-24523-00	.VALVE PACKING	1	1	1	
17	90202-05193	WASHER, PLATE	2	2	2	
18	90149-06011	SCREW	2	2	2	
19	90445-10007	HOSE (L110)	1	1	1	
20	90467-09W06	CLIP	2	2	2	
21	2FJ-24610-00	CAP ASSY	1	1	1	
22	90445-08824	HOSE	1	1	1	
23	1C6-F137W-00	SCOOP, AIR 1	1	1	1	
24	90387-060T4	COLLAR	2	2	2	
25	1B2-F1749-00	COLLAR	2	2	2	
26	90159-06182	SCREW, WITH WASHER	4	4	4	
27	90269-07076	RIVET	2	2	2	

FIG. 25 SEAT

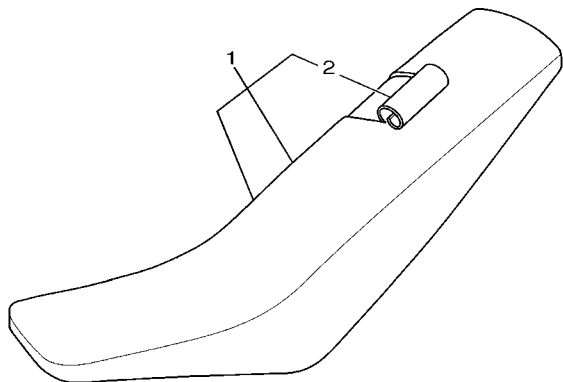

REF. NO.	PART NO.	DESCRIPTION	1C65	1C66	1C67			REMARKS
1	1C6-F4710-00	SINGLE SEAT ASSY	1	1	1			
2	1C6-F470F-00	.SEAT COVER COMP.	1	1	1			

1C61100-D250

D7

FIG. 26 FRONT WHEEL

REF. NO.	PART NO.	DESCRIPTION	1C65	1C66	1C67	REMARKS
1	4AN-F5111-10-35	HUB, FRONT	1	1	1	SL
2	93306-202XY	BEARING	2	2	2	
3	90560-15290	SPACER	1	1	1	
4	93106-20021	OIL SEAL	2	2	2	
5	94416-21536	RIM (1.60-21)	1	1	1	
6	1C6-F5104-00	SPOKE SET, FRONT	1	1	1	
7	94108-21800	TIRE (80/100-21 MT320H)	1	1	1	PIRELLI
8	94227-21848	TUBE (80/100-21 TR4)	1	1	1	PIRELLI
9	94325-21117	BAND,RIM (1.85-21)	1	1	1	YOKOHAMA
10	90387-15W36	COLLAR	2	2	2	
11	2TY-F5118-00	COVER, HUB DUST	2	2	2	
12	1C6-F5181-00	AXLE, WHEEL	1	1	1	
13	90201-15813	WASHER, PLATE	2	2	2	
14	95607-14100	NUT, U	1	1	1	

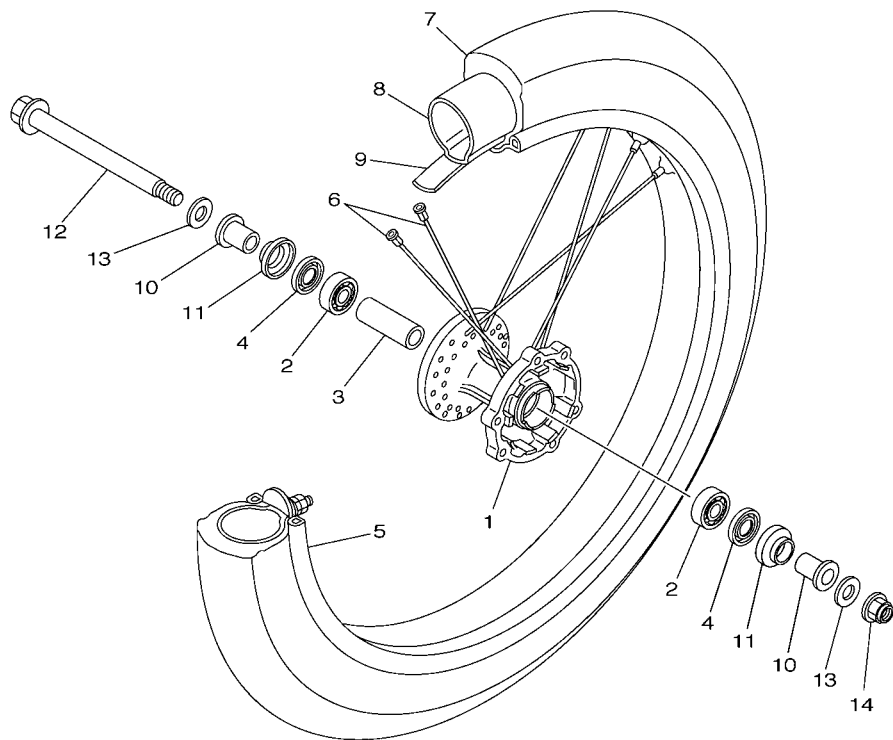

1C61100-D262

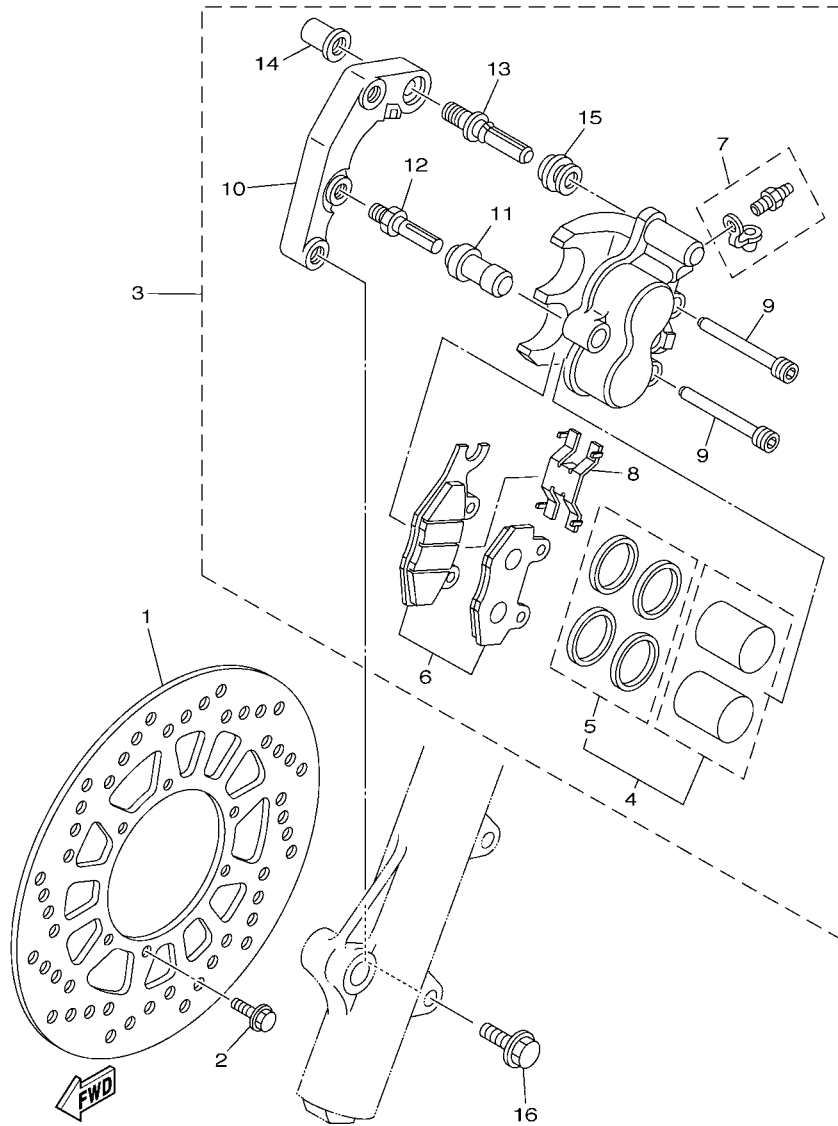

1C61100-D270

FIG. 27 FRONT BRAKE CALIPER

REF. NO.	PART NO.	DESCRIPTION	1C65	1C66	1C67	REMARKS
1	5RM-F582T-00	DISC, BRAKE (LEFT)	1	1	1	
2	90105-06813	BOLT, FLANGE	6	6	6	
3	5RM-F580T-00	CALIPER ASSY (LEFT)	1	1	1	
4	5RM-W0057-00	.PISTON ASSY, CALIPER	1	1	1	
5	5RM-W0047-00	..CALIPER SEAL KIT	1	1	1	
6	5RM-W0045-10	.BRAKE PAD KIT	1	1	1	
7	5HH-W0048-00	.BLEED SCREW KIT	1	1	1	
8	5HH-F5934-00	.SPRING, PAD	1	1	1	
9	5HH-F5924-00	.PIN, PAD	2	2	2	
10	5RM-F5921-00	.BRACKET, SUPPORT	1	1	1	
11	5HH-F5937-00	.BOOT 2	1	1	1	
12	5HH-F5926-00	.BOLT	1	1	1	
13	5HH-F536G-00	.PIN	1	1	1	
14	5HH-F5961-00	.NUT	1	1	1	
15	5HH-F5917-00	.BOOT, CALIPER	1	1	1	
16	90105-10638	BOLT, FLANGE	2	2	2	

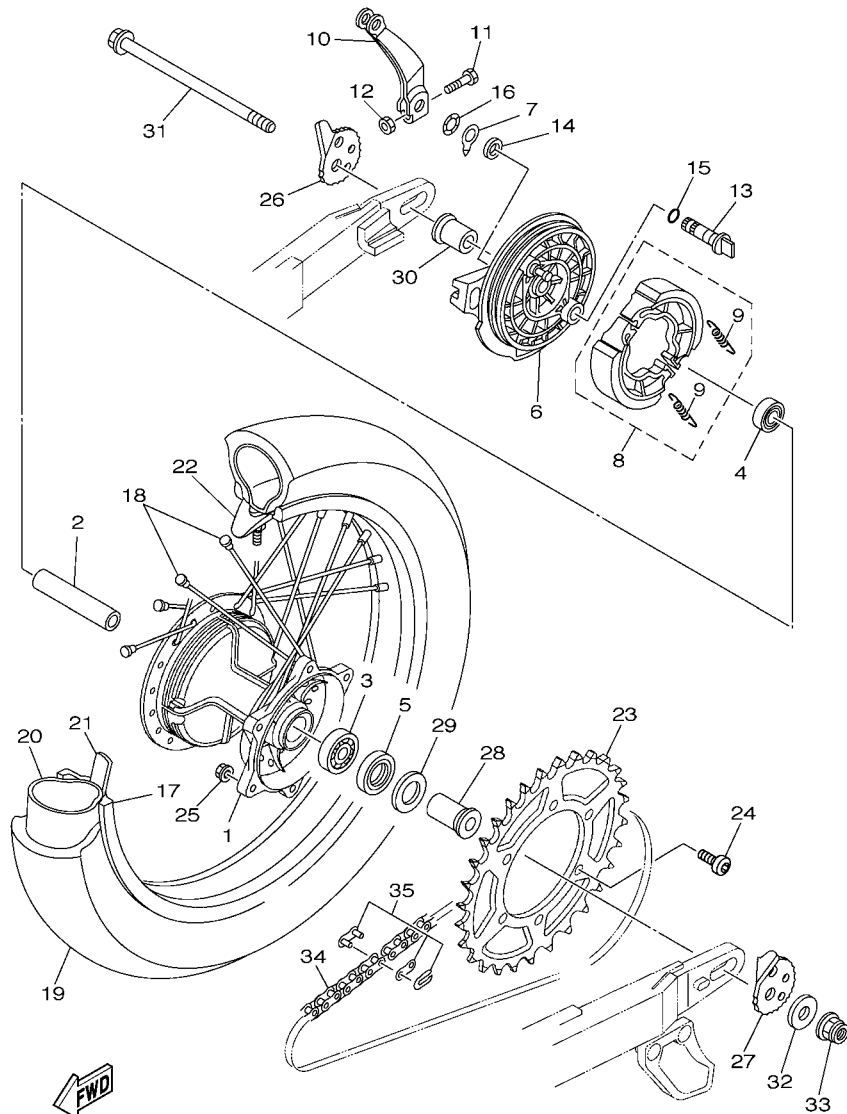

1C61100-D281

FIG. 28 REAR WHEEL

REF. NO.	PART NO.	DESCRIPTION	1C65	1C66	1C67	REMARKS
1	1C6-F5311-00-35	HUB, REAR	1	1	1	SL
2	5L9-F5317-00	SPACER, BEARING	1	1	1	
3	93306-302X7	BEARING	1	1	1	
4	93306-252Y2	BEARING	1	1	1	
5	93106-26005	OIL SEAL	1	1	1	
6	5RM-F5321-00-35	PLATE, BRAKE SHOE	1	1	1	SL
7	5HH-F533A-00	PLATE, INDICATOR	1	1	1	
8	5HH-F5330-00	BRAKE SHOE COMP.	1	1	1	
9	90506-15260	.SPRING, TENSION	2	2	2	
10	5RM-F5355-00	LEVER, CAMSHAFT	1	1	1	
11	90101-06W00	BOLT	1	1	1	
12	9530M-06600	NUT	1	1	1	
13	5RM-F5351-00	CAMSHAFT	1	1	1	
14	93109-14021	OIL SEAL	1	1	1	
15	93210-14104	O-RING	1	1	1	
16	90206-14093	WASHER, WAVE	1	1	1	
17	94418-18016	RIM (1.85-18)	1	1	1	
18	1C6-F5304-00	SPOKE SET, REAR	1	1	1	
19	94110-18801	TIRE (100/100-18 MT230)	1	1	1	PIRELLI
20	94210-18800	TUBE (100/100-18TR4)	1	1	1	PIRELLI
21	94325-18801	BAND, RIM (2.15-18)	1	1	1	PIRELLI
22	4XM-25394-00	SPACER, BEAD	1	1	1	
23	1C6-F5449-21	SPROCKET, DRIVEN (49T)	1	1	1	
24	90111-08826	BOLT, HEX. SOCKET BUTTON	6	6	6	
25	95607-08200	NUT, SELF-LOCKING	6	6	6	
26	5RM-F5389-00	PULLER, CHAIN 2	1	1	1	
27	1C6-F5389-00	PULLER, CHAIN 2	1	1	1	

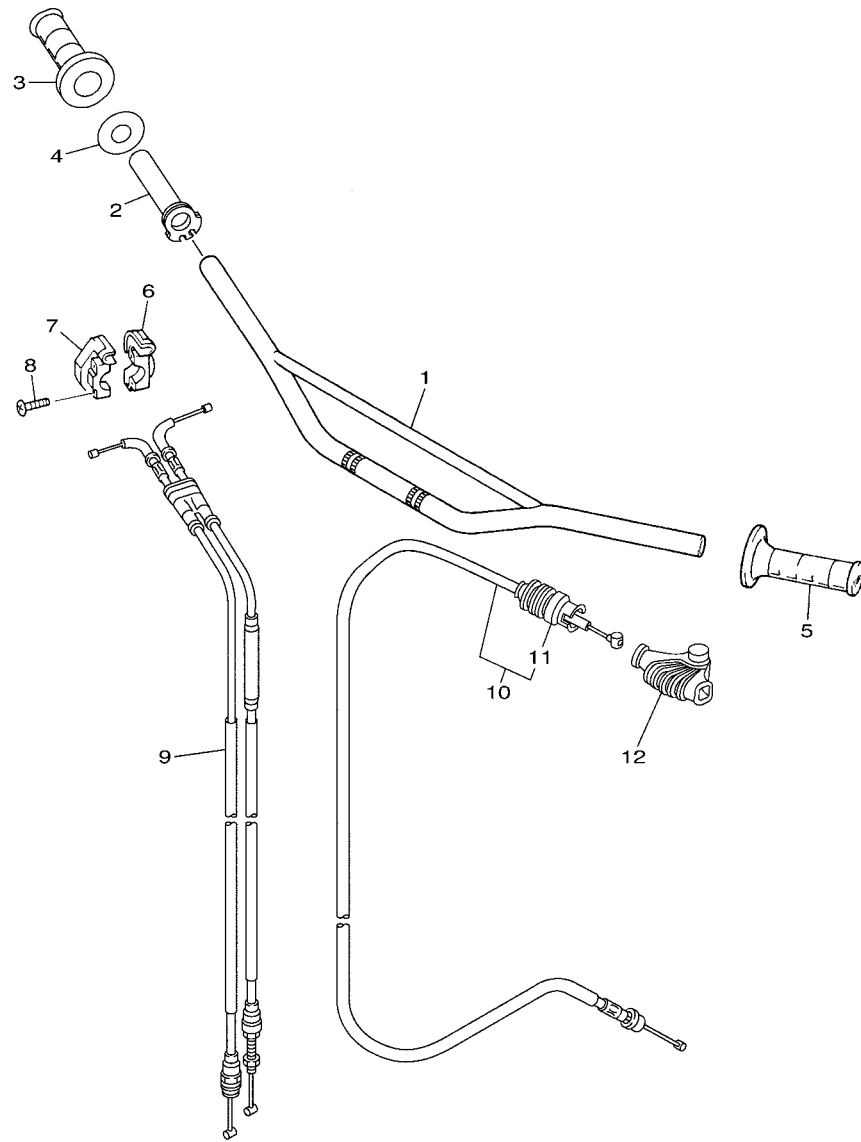



1C61100-D290

FIG. 29 STEERING HANDLE & CABLE

REF. NO.	PART NO.	DESCRIPTION	1C65	1C66	1C67	REMARKS
1	1C6-F6111-00	HANDLEBAR	1	1	1	
2	1C6-F6243-00	TUBE, THROTTLE GUIDE	1	1	1	
3	1C6-F6242-00	GRIP (RIGHT)	1	1	1	
4	2TY-F6249-00	RING, LEAF	1	1	1	
5	1C6-F6241-00	GRIP	1	1	1	
6	1C6-F6281-00	CAP, GRIP UPPER	1	1	1	
7	1C6-F6282-00	CAP, GRIP LOWER	1	1	1	
8	9851M-05020	SCREW, PAN HEAD	2	2	2	
9	1C6-26302-00	THROTTLE CABLE ASSY	1	1	1	
10	1C6-F6335-00	CABLE, CLUTCH	1	1	1	
11	2TY-F6342-00	.BOOT, CABLE	1	1	1	
12	5RM-F6372-00	COVER, HANDLE LEVER 1	1	1	1	

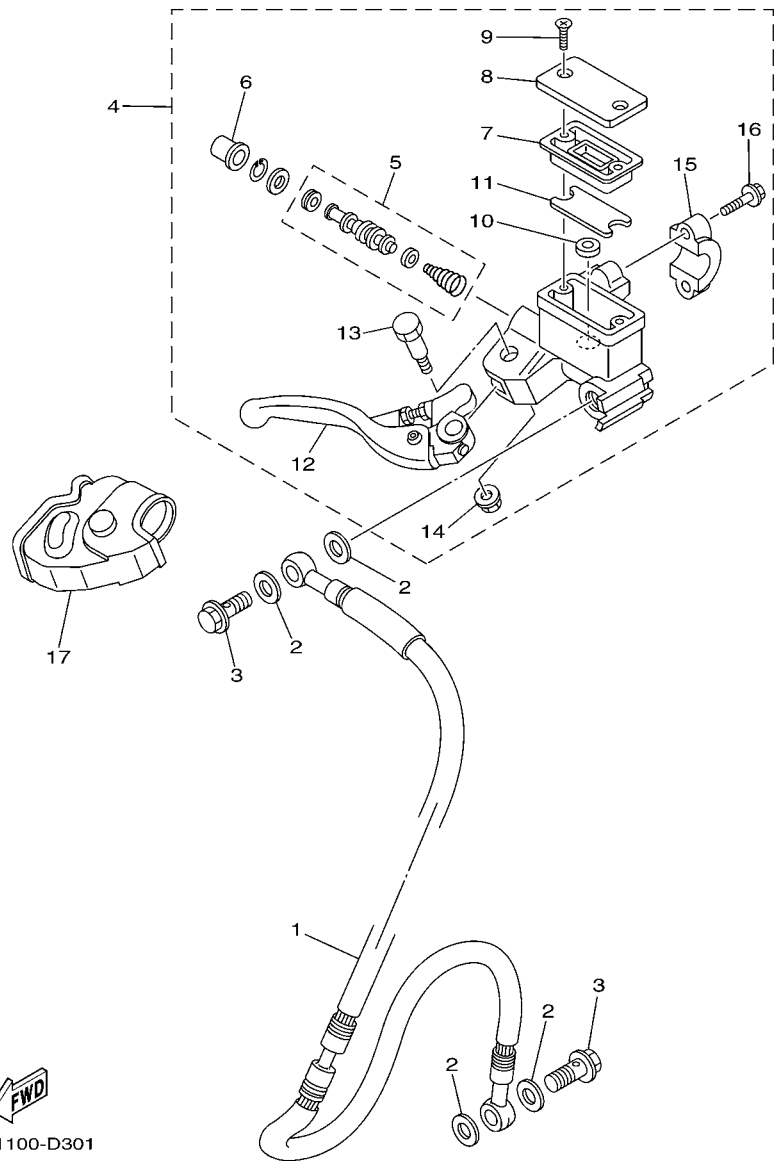
FIG. 30 FRONT MASTER CYLINDER



REF. NO.	PART NO.	DESCRIPTION	1C65	1C66	1C67	REMARKS
1	1C6-25872-00	HOSE, BRAKE 1	1	1	1	
2	90201-10118	WASHER, PLATE	4	4	4	
3	90401-10814	BOLT, UNION	2	2	2	
4	1C6-F583T-00	MASTER CYLINDER ASSY	1	1	1	
5	5NY-W0041-00	.CYLINDER KIT, MASTER	1	1	1	
6	5NY-25868-00	.BOOT, MASTER CYLINDER	1	1	1	
7	5XE-25854-00	.DIAPHRAGM, RESERVOIR	1	1	1	
8	2VN-25852-02	.CAP, RESERVOIR	1	1	1	
9	98706-04012	.SCREW, FLAT HEAD	2	2	2	
10	5CG-25715-00	.SEPARATOR ASSY	1	1	1	
11	5XE-25853-00	.FLOAT, RESERVOIR	1	1	1	
12	1C6-H3922-00	.LEVER 2	1	1	1	
13	90109-06577	.BOLT	1	1	1	
14	95706-06500	.NUT, FLANGE	1	1	1	
15	5HH-F5867-00	.BRACKET, MASTER CYLINDER	1	1	1	
16	5HH-F6332-00	.BOLT, FLANGE	2	2	2	
17	1C6-F6372-00	COVER, HANDLE LEVER 1	1	1	1	

FIG. 31 STAND & FOOTREST

REF. NO.	PART NO.	DESCRIPTION	1C65	1C66	1C67	REMARKS
1	1C6-F7211-00	PEDAL, BRAKE	1	1	1	
2	1B2-F7242-00	PEDAL, BRAKE	1	1	1	
3	90508-14352	SPRING, TORSION	1	1	1	
4	91701-06022	PIN, CLEVIS	1	1	1	
5	91401-20012	PIN, COTTER	1	1	1	
6	5RM-F7261-00	SHAFT	1	1	1	
7	90201-10135	WASHER, PLATE	1	1	1	
8	90206-14001	WASHER, WAVE	1	1	1	
9	90468-20196	CLIP	1	1	1	
10	90506-18804	SPRING, TENSION	1	1	1	
11	9700M-06016	BOLT	1	1	1	
12	9530M-06700	NUT	1	1	1	
13	1C6-F7231-00	ROD, BRAKE	1	1	1	
14	91701-06020	PIN, CLEVIS	1	1	1	
15	9290M-06200	WASHER	2	2	2	
16	91401-20012	PIN, COTTER	1	1	1	
17	90501-10802	SPRING, COMPRESSION	1	1	1	
18	90249-12800	PIN	1	1	1	
19	90175-06020	NUT, WING	1	1	1	
20	1C6-F7311-00	STAND, SIDE	1	1	1	
21	90101-10805	BOLT	1	1	1	
22	90387-10003	COLLAR	1	1	1	
23	90185-10037	NUT, SELF-LOCKING	1	1	1	
24	90506-35805	SPRING, TENSION	1	1	1	
25	1B2-F7411-00	FOOTREST 1	1	1	1	
26	90508-28777	SPRING, TORSION	1	1	1	
27	90240-10117	PIN, CLEVIS	1	1	1	

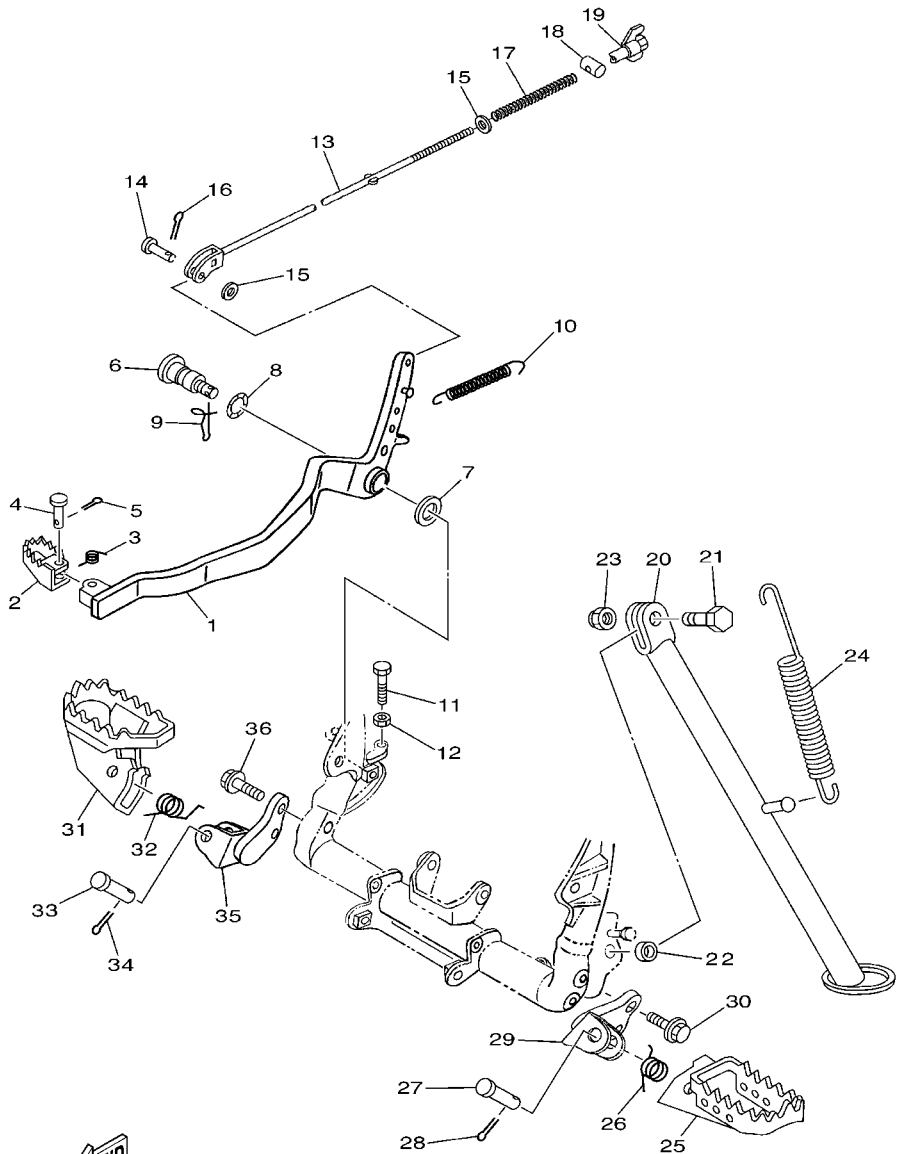

1C61100-D310

FIG. 32 GENERATOR

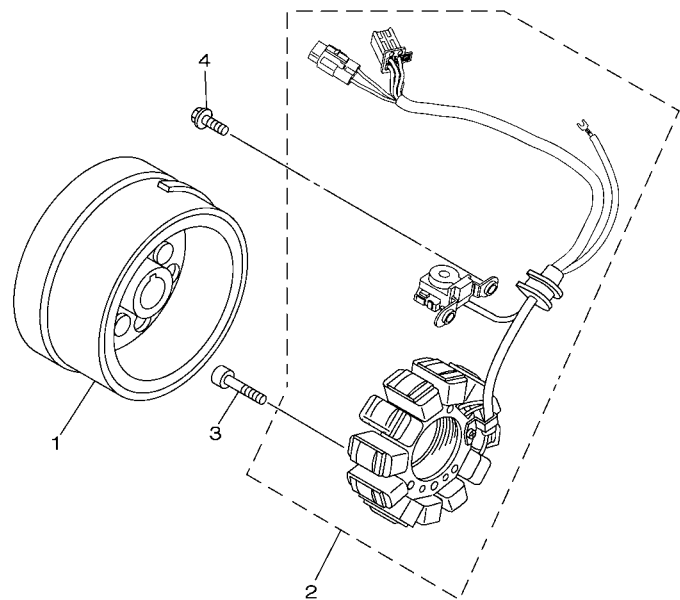

REF. NO.	PART NO.	DESCRIPTION	1C65	1C66	1C67	REMARKS
1	1C6-H1450-00	ROTOR ASSY	1	1	1	
2	1C6-H1410-00	STATOR ASSY	1	1	1	
3	9201M-06020	BOLT, BUTTON HEAD	5	5	5	
4	9502M-06025	BOLT, FLANGE	2	2	2	

1C61100-D320

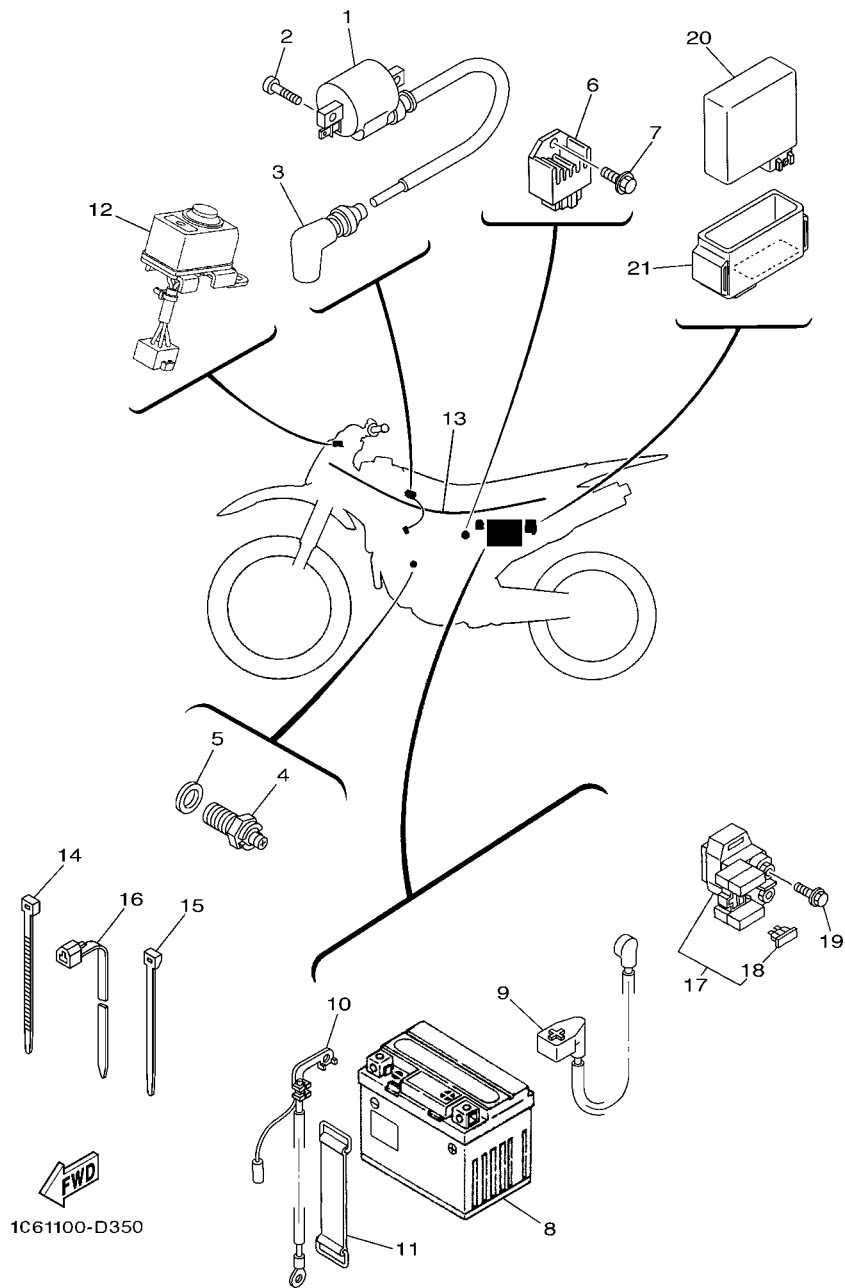

FIG. 35 ELECTRICAL 1

REF. NO.	PART NO.	DESCRIPTION	1C65	1C66	1C67	REMARKS
1	3NS-82310-10	IGNITION COIL ASSY	1	1	1	
2	9502M-06016	BOLT, FLANGE	2	2	2	
3	3NS-82370-00	PLUG CAP ASSY	1	1	1	
4	4GY-82540-10	NEUTRAL SWITCH ASSY	1	1	1	
5	90430-10148	GASKET	1	1	1	
6	5HH-H1960-00	RECTIFIER & REGULATOR ASSY	1	1	1	
7	9502M-06012	BOLT, FLANGE	1	1	1	
8	1C6-H2110-00	BATTERY ASSY(YTX5L-BS 12V-4AH)	1	1	1	YUASA
9	1C6-H2115-00	WIRE, PLUS LEAD	1	1	1	
10	1C6-H2116-00	WIRE, MINUS LEAD	1	1	1	
11	1C6-H2131-00	BAND, BATTERY	1	1	1	
12	1C6-82510-00	MAIN SWITCH ASSY	1	1	1	
13	1C6-H2590-00	WIRE HARNESS ASSY	1	1	1	
14	90465-13275	CLAMP	3	3	3	
15	90465-13152	CLAMP	6	6	6	
16	90464-13077	CLAMP	4	4	4	
17	5HH-81940-02	STARTER RELAY ASSY	1	1	1	
18	42X-82151-00	.FUSE (10A-BL)	2	2	2	
19	9502M-06008	BOLT, FLANGE	2	2	2	
20	1C6-H5540-00	C.D.I. UNIT ASSY	1	1	1	
21	1C6-H5546-00	BAND	1	1	1	

NUMERICAL INDEX

PART NO.	GRID NO.	PART NO.	GRID NO.	PART NO.	GRID NO.	PART NO.	GRID NO.	PART NO.	GRID NO.	PART NO.	GRID NO.
1C6-11101-00	B - 2	5H0-13440-00	B - 8	2LN-16154-00	C - 2	1KH-23144-00	D - 3	1C6-E4437-00	B - 9	1C6-F173N-00	C - 12
5H0-1111F-00	B - 2	16G-13569-00	B - 9	36X-16321-00	C - 2	1KH-23145-00	D - 3	5HH-E443E-01	B - 9	1C6-F1746-00	C - 12
5H0-11133-11	B - 2	1C6-14105-00	B - 10	537-16321-00	C - 2	1KH-23147-00	D - 3	1C6-E4452-00	B - 9	1C6-F1747-00	C - 12
1KH-11145-00	B - 5	42U-14146-00	B - 10	137-16324-00	C - 2	34X-23151-00	D - 3	1C6-E4453-00	B - 9	1B2-F1749-00	D - 5
15A-11161-01	B - 2	5Y1-14146-00	B - 10	5H0-16351-00	C - 2	34X-23156-00	D - 3	1C6-E4458-00	B - 9	1C6-F174A-00	C - 12
15A-11162-00	B - 2	1KH-14149-00	B - 10	4JG-16356-00	C - 2	34X-23157-00	D - 3	1C6-E4459-00	B - 9	1C6-F174T-00	C - 12
5H0-11162-00	B - 2	1KH-14153-00	B - 11	5H0-16357-00	C - 2	35E-23168-00	D - 3	1C6-E4462-00	B - 9	1C6-F174X-00	C - 12
371-11167-01	B - 13	5Y1-14159-00	B - 10	1W1-16358-01	C - 2	3M7-23181-00	D - 3	1C6-E4472-00	B - 9	1C6-F174Y-00	C - 12
59V-11181-00	B - 2	1C6-14197-00	B - 10	2LN-16371-00	C - 2	35E-23183-00	D - 3	1B2-E4477-00	B - 9	1C6-F1778-00	C - 12
4VW-11310-00	B - 3	5Y1-14198-00	B - 10	4JG-16380-01	C - 2	1C6-23191-00	D - 4	4VW-E4628-00	B - 12	1C6-F177G-00	C - 12
5VC-11351-00	B - 3	4PT-14291-10	B - 10	1KH-16383-00	C - 2	4JG-23416-00	D - 2	1C6-E4711-00	B - 12	1C6-F2110-00-35	C - 13
3RW-11400-00	B - 4	1C6-14301-00	B - 10	17T-17121-00	C - 4	1C6-24110-00	D - 5	4VW-E5150-01	B - 13	1C6-F2117-00	C - 13
1KH-11454-00	B - 4	1XL-14313-28	B - 10	1KH-17131-01	C - 4	3PT-2416E-10	C - 9	1C6-E531A-00	B - 13	5L9-F2127-00	C - 13
5H0-11496-00	B - 4	14T-14323-00	B - 10	5MP-17151-00	C - 4	5XE-24176-00	D - 5	4VW-E5351-00	B - 8	5L9-F2128-00	C - 13
2LN-11530-00	B - 4	4PT-14325-00	B - 10	5MP-17161-00	C - 4	4FU-24181-00	B - 12	1C6-E5411-00-WN	B - 14	1C6-F2141-00	C - 13
5H0-11536-00	B - 4	1C6-14341-00	B - 10	5BT-17211-00	C - 4	1C6-24500-01	D - 5	1C6-E5420-00-WN	B - 14	1B2-F2151-10	C - 13
29U-11610-00	B - 4	1C6-14342-18	B - 10	17T-17221-01	C - 4	360-24512-00	B - 10	1C6-E5484-00	B - 14	1B2-F2178-00	C - 8
29U-11610-20	B - 4	288-14343-63	B - 10	17T-17241-03	C - 4	4X8-24512-00	D - 5	1C6-E5758-00	B - 14	5RM-F2178-00	C - 8
29U-11610-40	B - 4	30X-14358-00	B - 11	5MP-17251-00	C - 4	3AC-24523-00	D - 5	4VW-E7231-01	C - 4	1C6-F217F-00	C - 14
1KH-11631-01-CO	B - 4	1KH-14371-01	B - 10	5MP-17261-00	C - 4	3AJ-24534-01	D - 5	1C6-E7402-00	C - 4	5RM-F2184-00	C - 8
15A-11633-00	B - 4	5Y1-14384-00	B - 10	5H0-18120-02	C - 7	2FJ-24610-00	D - 5	1C6-E7411-00	C - 4	5RM-F2199-00	C - 13
1KH-11636-01	B - 4	5Y1-14385-00	B - 10	1RH-18140-00	C - 6	4XM-25394-00	D - 10	4AN-E7456-00	C - 5	1C6-F3102-00	D - 3
1KH-11638-01	B - 4	689-14386-00	B - 10	4JG-18185-00	C - 6	5CG-25715-00	D - 13	1C6-E7466-00	B - 14	1C6-F3103-00	D - 3
29U-11651-00	B - 4	4KL-14390-20	B - 10	4JG-18511-00	C - 6	2VN-25852-02	D - 13	1C6-E8110-00	C - 7	1C6-F3110-00	D - 3
5H0-11681-00	B - 4	1C6-14396-00	B - 10	4JG-18512-01	C - 6	5XE-25853-00	D - 13	1C6-F1110-00	C - 8	4AN-F3111-00	D - 3
5H0-12111-02	B - 6	1C6-14451-00	B - 9	4JG-18513-00	C - 6	5XE-25854-00	D - 13	1C6-F1315-00	C - 8	4AN-F3114-00	D - 3
11H-12113-00	B - 6	5Y1-14536-00	B - 10	3GX-18531-00	C - 6	5NY-25868-00	D - 13	1C6-F1316-00	C - 8	1C6-F3126-00	D - 3
11H-12114-00	B - 6	1C6-14611-00	B - 12	3GX-18535-00	C - 6	1C6-25872-00	D - 13	1C6-F137N-10	D - 6	1C6-F3136-00	D - 3
4G0-12116-01	B - 6	15A-14612-00	B - 12	4JG-18540-00	C - 6	1C6-26302-00	D - 12	1C6-F137P-10	D - 6	4AN-F3166-00	D - 3
4G0-12117-00	B - 6	4BE-14613-00	B - 12	136-18542-00	C - 6	5HH-81940-02	E - 5	1C6-F137W-00	D - 5	1C6-F3171-00	D - 3
4G0-12118-00	B - 6	3YF-14714-00	B - 12	278-21183-01	C - 9	42X-82151-00	E - 5	1C6-F137X-00	D - 6	4AN-F3192-00	D - 4
5H0-12119-00	B - 6	4BD-14766-00	B - 12	3PT-2118K-A0	C - 11	3NS-82310-10	E - 5	1C6-F1471-00	C - 8	4AN-F3192-10	D - 4
5H0-12121-01	B - 6	1C6-14780-00	B - 12	3PT-2118K-B0	C - 11	3NS-82370-00	E - 5	1C6-F1485-00	C - 8	1C6-F319U-00	D - 2
5H0-12146-00	B - 6	5Y1-1490A-00	B - 11	3XJ-2151H-A1	C - 11	3JK-82377-00	C - 9	1C6-F1511-00	C - 10	1C6-F331E-00	D - 4
29U-12151-00	B - 6	1C6-1490J-00	B - 10	3XJ-2151H-B1	C - 11	1C6-82510-00	E - 5	5RM-F1511-00	C - 10	1C6-F3340-00	D - 4
5H0-12156-00	B - 6	5DS-1490K-00	B - 10	5PA-21568-00	C - 11	4GY-82540-10	E - 5	1B2-F153E-00	C - 10	4AN-F3346-00	D - 4
2NX-12159-00	B - 6	3Y1-15361-00	B - 14	3RV-21668-A0	C - 14	5TJ-82917-01	E - 4	1C6-F1611-00	C - 10	1C6-F3351-00	D - 3
1KH-12171-00	B - 7	3Y1-15363-00	B - 14	3RV-21668-B0	D - 2	5TJ-83976-01	E - 4	1C6-F1611-10	C - 10	1C6-F3389-00	D - 4
2LN-12176-00	B - 7	4JG-15441-02	B - 13	1C6-2179C-00	C - 8	5TJ-83976-11	E - 4	1C6-F1635-00	C - 10	5HH-F3418-00	D - 2
2HT-12210-10	B - 7	4BE-15451-03	B - 14	1C6-2217A-00	C - 13	11H-85110-01	C - 10	1C6-F163A-00	C - 10	1C6-F3435-00	D - 2
4FM-12213-00	B - 7	4BE-15462-00	B - 14	1C6-22210-00	C - 15	3Y6-85130-02	C - 10	1C6-F163E-00	C - 10	3V9-F3441-10	D - 2
5H0-12231-00	B - 7	2HT-15512-00	B - 15	1C6-22210-10	C - 15	4VW-E1185-10	B - 2	1C6-F163G-10	C - 11	1C6-F3485-00	D - 2
5N0-12241-00	B - 7	4JG-15517-00	B - 15	1C6-22210-20	C - 15	4VW-E1186-10	B - 2	5RM-F1642-00	C - 10	1C6-F3486-00	D - 2
5H0-13300-02	B - 8	5H0-15521-00	B - 15	4AA-22259-40	C - 15	4VW-E1187-10	B - 2	1C6-F164F-00	C - 10	1B2-F412F-00	D - 5
5H0-13326-01	B - 8	4H7-15580-10	B - 15	4AA-22259-70	C - 15	4VW-E3447-00	B - 8	1C6-F164G-00	C - 10	1C6-F4173-00	D - 5
5H0-13327-00	B - 8	1J7-15583-01	B - 15	4AA-22259-80	C - 15	1C6-E3586-00	B - 9	1C6-F1711-00	C - 12	1C6-F4181-00	D - 5
4BE-13329-01	B - 8	5H0-16111-00	C - 2	34X-23125-00	D - 3	1C6-E4411-00	B - 9	1C6-F1720-00	C - 12	1C6-F4182-00	D - 5
51Y-13411-00	B - 8	1KH-16150-00	C - 2	34X-23135-00	D - 3	1C6-E4412-00	B - 9	1C6-F173M-00	C - 12	1B2-F4186-00	D - 5

NUMERICAL INDEX

PART NO.	GRID NO.	PART NO.	GRID NO.	PART NO.	GRID NO.	PART NO.	GRID NO.	PART NO.	GRID NO.	PART NO.	GRID NO.
1C6-F470F-00	D - 7	1B2-F7411-00	D - 14	90109-06577	D - 13	90201-15813	D - 8	90387-124F4	C - 7	90508-26705	C - 7
1C6-F4710-00	D - 7	1C6-F7412-00	D - 15	90109-065G0	B - 8	90201-164K2	C - 4	90387-125F1	B - 13	90508-28777	D - 14
1C6-F5104-00	D - 8	1C6-F7421-00	D - 15	90109-085E2	B - 12	90201-17257	C - 4	90387-125Y0	B - 15	90560-15290	D - 8
4AN-F5111-10-35	D - 8	1C6-F7422-00	D - 15	90111-08826	D - 10	90201-201E4	B - 4	90387-127F2	C - 13	9131M-06016	D - 2
2TY-F5118-00	D - 8	1C6-H1410-00	E - 2	90119-06018	C - 12	90201-203E7	C - 4	90387-14007	C - 13	9131M-06018	B - 2
1C6-F5181-00	D - 8	1C6-H1450-00	E - 2	90119-06044	B - 9	90201-25290	B - 15	90387-15W34	D - 11	9131M-06020	B - 9
1C6-F5304-00	D - 10	1C6-H1800-00	E - 3	90119-06118	C - 8	90202-05193	D - 5	90387-15W35	D - 11		B - 12
1C6-F5311-00-35	D - 10	4FP-H1801-00	E - 3	90119-08238	C - 12	90202-26142	D - 2	90387-15W36	D - 8	9131M-06025	B - 3
5L9-F5317-00	D - 10	4FP-H1828-01	E - 3	90123-08046	E - 4	90206-06090	B - 12	90387-255F3	B - 7		B - 7
5RM-F5321-00-35	D - 10	1C6-H183G-00	E - 3	90149-06011	D - 5	90206-14001	D - 14	90401-10814	D - 13	9131M-08020	B - 15
5HH-F5330-00	D - 10	5HH-H1960-00	E - 5	90149-08067	C - 2	90206-14093	D - 10	90430-06014	B - 2	9131M-08045	B - 2
5HH-F533A-00	D - 10	1C6-H2110-00	E - 5	90151-06013	C - 6	90209-17285	C - 4	90430-08119	C - 2	91401-20012	D - 14
5RM-F5351-00	D - 10	1C6-H2115-00	E - 5	90153-06029	B - 2	90209-18208	C - 4	90430-10148	E - 5	91401-25015	D - 15
5RM-F5355-00	D - 10	1C6-H2116-00	E - 5	90159-05011	C - 2	90214-20023	B - 4	90430-12186	B - 2	91701-06020	D - 14
4AN-F5367-00	D - 11	1C6-H2131-00	E - 5	90159-06182	D - 5	90215-06184	B - 2	90445-08824	D - 5	91701-06022	D - 14
5HH-F536G-00	D - 9	1C6-H2590-00	E - 5	90170-06128	B - 6	90215-14186	C - 2	90445-10007	D - 5	91810-16016	B - 2
1C6-F5381-00	D - 11	2TY-H2911-00	E - 4	90170-14284	B - 5	90215-14205	B - 5	90460-46206	B - 9		B - 3
1C6-F5389-00	D - 10	1B2-H2913-00	E - 4		C - 2		C - 2	90460-49293	B - 9	9201M-06010	B - 14
5RM-F5389-00	D - 10	1C6-H350E-00	D - 2	90175-06012	B - 9	90240-07083	B - 4	90462-08224	B - 13	9201M-06020	E - 2
1C6-F5449-21	D - 10	1B2-H3912-00	E - 4	90175-06020	D - 14	90240-10117	D - 14	90462-08225	B - 14	92907-06200	C - 2
5RM-F580T-00	D - 9	1C6-H3922-00	D - 13	90179-08148	E - 4	90249-12800	D - 14	92907-13077	E - 5	92907-06600	B - 7
5RM-F582T-00	D - 9	4LR-H3945-00	E - 4	90179-22412	D - 2	90267-40802	C - 8	90465-08127	B - 13	9290M-05100	E - 4
1C6-F583T-00	D - 13	1C6-H5540-00	E - 5	90179-25W22	D - 2	90267-40804	C - 10	90465-08200	B - 13	9290M-06200	D - 14
5HH-F5867-00	D - 13	1C6-H5546-00	E - 5	90179-25W23	D - 2	90269-07076	D - 5	90465-13152	E - 5	9290M-06600	B - 9
5HH-F5917-00	D - 9	5NY-W0041-00	D - 13	90183-06023	B - 9	90280-05013	B - 5	90465-13275	D - 5	93101-15101	C - 4
5RM-F5921-00	D - 9	5RM-W0045-10	D - 9	90185-06W10	E - 4	90282-05013	B - 4		E - 5	93101-25106	B - 5
5HH-F5924-00	D - 9	5RM-W0047-00	D - 9	90185-10037	D - 14	90282-05043	C - 2	90465-14242	D - 2	93102-12106	C - 7
5HH-F5926-00	D - 9	5HH-W0048-00	D - 9	90185-12134	C - 13	90338-16148	C - 8	90467-09W06	D - 5	93102-14209	C - 3
5HH-F5934-00	D - 9	5RM-W0057-00	D - 9	90185-14112	D - 11	90340-14128	B - 14	90467-10039	B - 9	93102-20004	C - 4
5HH-F5937-00	D - 9	4VW-WE543-00	B - 14	90201-04018	C - 10	90340-32123	B - 14	90467-14015	B - 13	93106-20021	D - 8
5HH-F5961-00	D - 9	90101-06W00	D - 10	90201-042E0	C - 8	90380-18139	C - 13	90467-15012	B - 9	93106-26005	D - 10
1C6-F6111-00	D - 12	90101-10188	B - 5	90201-05W39	C - 10	90385-12039	B - 2	90468-20196	D - 14	93109-14021	D - 10
1C6-F6241-00	D - 12	90101-10303	B - 7	90201-06735	B - 9	90386-18146	C - 13	90480-13426	D - 6	93109-17071	C - 14
1C6-F6242-00	D - 12	90101-10805	D - 14	90201-06804	C - 10	90387-06023	C - 10	90480-13428	D - 2	93109-18020	C - 13
1C6-F6243-00	D - 12	90101-12804	C - 14	90201-08326	B - 12	90387-060A3	C - 8	90480-18549	D - 5	93109-20076	C - 13
2TY-F6249-00	D - 12	90105-05361	D - 4	90201-08609	B - 2	90387-060T4	C - 10	90501-04596	B - 15	93210-07135	B - 8
1C6-F6281-00	D - 12	90105-064A6	B - 8	90201-08753	C - 8		D - 5	90501-07629	B - 4	93210-09165	B - 6
1C6-F6282-00	D - 12	90105-06813	D - 9	90201-09801	C - 8	90387-061V4	C - 10	90501-10802	D - 14	93210-13361	B - 3
5HH-F6332-00	D - 13	90105-06830	B - 13	90201-100E9	C - 15	90387-062X0	C - 13	90501-18576	B - 8	93210-14104	D - 10
1C6-F6335-00	D - 12	90105-08195	B - 2	90201-10118	D - 13	90387-064J1	D - 2	90501-21133	B - 4	93210-14800	B - 14
2TY-F6342-00	D - 12	90105-08846	C - 8	90201-10135	D - 14	90387-06681	C - 10	90501-23700	C - 2	93210-19123	B - 14
1C6-F6372-00	D - 13	90105-08852	C - 8	90201-101J1	C - 8		C - 12	90506-08227	C - 7	93210-25711	E - 3
5RM-F6372-00	D - 12	90105-08856	C - 8		C - 14	90387-06737	C - 13	90506-15260	D - 10	93210-32800	B - 14
1C6-F7211-00	D - 14	90105-10638	D - 9	90201-10508	B - 5	90387-10003	D - 14	90506-18804	D - 14	93210-347A1	B - 8
1C6-F7231-00	D - 14	90105-10818	C - 14	90201-10591	B - 7	90387-1012A	C - 14	90506-35805	D - 14	93210-35537	B - 9
1B2-F7242-00	D - 14	90105-10819	C - 15	90201-12588	C - 7	90387-12023	C - 14	90508-14352	D - 14	93210-48364	C - 2
5RM-F7261-00	D - 14	90105-12800	C - 14	90201-126A7	C - 13	90387-12024	C - 14	90508-18495	C - 2	93210-54175	B - 8
1C6-F7311-00	D - 14	90105-12801	C - 13	90201-15797	D - 11	90387-121N2	C - 13	90508-26539	C - 6	93210-55669	E - 3

NUMERICAL INDEX

PART NO.	GRID NO.	PART NO.	GRID NO.	PART NO.	GRID NO.	PART NO.	GRID NO.	PART NO.	GRID NO.	PART NO.	GRID NO.
93210-57634	B - 2	9502L-06010	B - 12	97801-05012	B - 11						
93210-72529	B - 3	9502M-06008	E - 5	98501-04010	B - 11						
93211-05471	B - 2	9502M-06012	E - 5	98517-03008	D - 5						
93306-20201	C - 4	9502M-06014	D - 2	9851M-05020	D - 12						
93306-202XY	D - 8	9502M-06016	E - 5		E - 4						
93306-20332	C - 4	9502M-06020	B - 2	98706-04012	D - 13						
93306-20401	C - 4	9502M-06025	B - 8	9870M-06025	D - 5						
93306-20532	B - 4			9870M-06030	B - 8						
93306-252Y2	D - 10			98901-04006	B - 10						
93306-302X7	D - 10	9502M-06030	B - 13	9890M-06010	B - 12						
93306-30424	C - 4	9502M-06035	B - 14	9890M-06016	D - 5						
93306-30427	B - 4	9502M-06040	B - 13	9890M-06020	B - 9						
93306-30611	B - 4	9502M-06045	B - 14	99001-10600	C - 7						
93310-530J3	B - 4	9502M-06085	B - 13	99009-17400	C - 4						
93315-23607	C - 6	9502M-06090	B - 13	99530-12016	B - 13						
93315-31428	C - 3	9502M-08012	C - 8		B - 14						
93315-31758	C - 14	9502M-08025	B - 12	9Y581-47105	D - 11						
93315-32056	C - 13	9502M-08035	D - 2								
93332-00001	D - 2	9502M-08040	D - 2								
93332-00008	D - 2	9502M-10025	D - 15								
93410-20038	C - 4	95307-06600	C - 2								
93410-22039	C - 4	9530M-06600	D - 10								
93420-28055	C - 3	9530M-06700	D - 14								
93440-10085	B - 2	95607-08200	C - 8								
93450-17044	B - 4		D - 10								
93505-16006	C - 2	95607-14100	D - 8								
93602-13177	B - 4	95617-10100	C - 14								
93603-12030	B - 8		C - 15								
93604-10011	B - 7	95617-12100	C - 13								
93604-16092	C - 6	95706-06500	D - 13								
93604-20156	C - 6	9570M-05500	C - 10								
93605-10090	B - 4	9570M-06500	C - 12								
93608-50158	C - 7	9580M-06012	C - 10								
93612-16254	B - 2	9580M-06014	D - 2								
93615-12088	B - 15	9581M-08055	C - 8								
93700-06803	C - 13	9581M-10020	C - 8								
93832-13164	C - 4	9582M-06016	C - 12								
94108-21800	D - 8	9582M-06030	C - 10								
94110-18801	D - 10	9700M-06012	B - 2								
94210-18800	D - 10	9700M-06016	C - 11								
94227-21848	D - 8		C - 13								
94325-18801	D - 10		D - 14								
94325-21117	D - 8	9700M-06020	C - 10								
94416-21536	D - 8	97027-06016	B - 7								
94418-18016	D - 10	9702M-06010	C - 5								
94580-41104	B - 7	9702M-06020	C - 7								
94681-47011	D - 11	97601-04114	B - 10								
94700-00333	B - 2	97601-05108	E - 3								