

SUZUKI

LT160E

SERVICE MANUAL



FOREWORD

The SUZUKI LT160E was designed to offer superior performance through four stroke power, equipped with a reverse gear. The suspension system consists of "wishbone" for front and "swingarm" for rear.

This service manual has been produced primarily for experienced mechanics whose job is to inspect, adjust, repair and service SUZUKI vehicles. Apprentice mechanics and "do it yourself" mechanics will also find this manual to be an extremely useful guide.

The LT160E, manufactured to standard specifications, is the main subject matter of this manual. However, the LT160E machines distributed in your country might differ in minor respects from the standard-specification and, if they do, it is because some minor modifications (which are of no consequence in most cases as far as servicing is concerned) had to be made to comply with the statutory requirements of your country.

This manual contains up-to-date information at the time of its issue. Later made modifications and changes will be explained to each SUZUKI distributor in respective markets, to whom you are kindly requested to make query about updated information, if any.

SUZUKI MOTOR CORPORATION

GROUP INDEX

GENERAL INFORMATION	1
PERIODIC MAINTENANCE AND TUNE-UP PROCEDURES	2
ENGINE	3
FUEL AND LUBRICATION SYSTEM	4
ELECTRICAL SYSTEM	5
CHASSIS	6
SERVICING INFORMATION	7
LT-F160EL ('90-MODEL)	8
LT-F160L/M ('90, '91-MODELS)	9
LT160EM/N ('91, '92-MODELS)	10
LT-F160N/P ('92, '93-MODELS)	11
LT-F160R/S/T/V (1994 to 1997-MODELS)	12
LT-F160W/X ('98, '99-MODELS)	13
LT-F160Y/K1/K2 ('00, '01, '02-MODELS)	14
LT160K3/K4 ('03, '04-MODELS) LT-F160K3/K4/K5 ('03, '04 '05-MODELS)	15

VIEW OF LT160E



LEFT SIDE



RIGHT SIDE

CONTENTS

VIN AND SERIAL NUMBER LOCATIONS	1-1
FUEL AND OIL RECOMMENDATIONS	1-1
BREAKING-IN PROCEDURE	1-2
SPECIAL MATERIALS	1-3
PRECAUTIONS AND GENERAL INSTRUCTIONS	1-6
SPECIFICATIONS	1-7

VIN AND SERIAL NUMBER LOCATIONS

The VIN number ① is stamped on the left frame member as shown in photograph. The engine serial number ② is located on the crankcase.

These numbers are required especially for registering the machine and ordering spare parts.

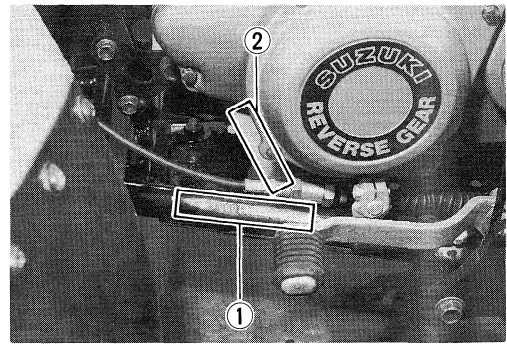

FUEL AND OIL RECOMMENDATIONS

FUEL

For U.S.A. model

1. Use only unleaded or low-lead type gasoline of at least 85 – 95 pump octane ($\frac{R+M}{2}$) methods or 89 octane or higher rated by the research method.
2. SUZUKI recommends that customers use alcohol free, unleaded gasoline whenever possible.
3. Use of blended gasoline containing MTBE (Methyl Tertiary Butyl Ether) is permitted.
4. Use of blended gasoline/alcohol fuel is permitted provided that it contains not more than 10% ethanol. Gasoline/alcohol fuel may contain up to 5% methanol if appropriate cosolvents and corrosion inhibitors are present.
5. If the performance of the vehicle is unsatisfactory while using blended gasoline/alcohol fuel, you should switch to alcohol free unleaded gasoline.
6. Failure to follow these guideline could possibly void applicable warranty coverage. Check with your fuel supplier to be sure that the fuel you intend to use meets the requirements listed above.

For CANADA model

Use only unleaded or low-lead type gasoline of at least 85 – 95 pump octane ($\frac{R+M}{2}$ method) or 89 octane or higher rated by the Research Method.

For other models

Gasoline used should be graded 85 – 95 octane or higher. An unleaded or low-lead type gasoline is recommended.

ENGINE OIL

For U.S.A. model

SUZUKI recommends the use of SUZUKI PERFORMANCE 4 MOTOR OIL or an oil which is rated SE or SF under the API (American Petroleum Institute) classification system. The viscosity rating is SAE 10W/40. If an SAE 10W/40 motor oil is not available, select an alternate according to the following chart.

For other models

Be sure that the engine oil you use comes under API classification of SE or SF and that its viscosity rating is SAE 10W/40. If an SAE 10W/40 motor oil is not available, select the oil viscosity according to the following chart:

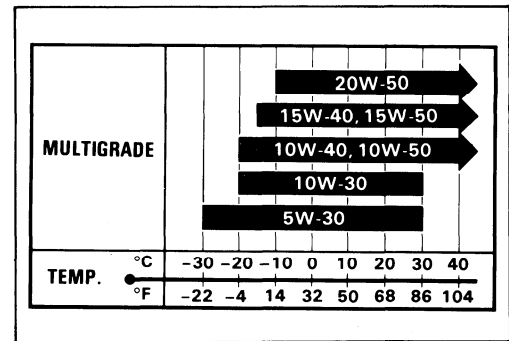

BREAKING-IN PROCEDURE

During manufacture only the best possible materials are used and all machined parts are finished to a very high standard, but it is still necessary to allow the moving parts to "BREAK-IN" before subjecting the engine to maximum stresses. The future performance and reliability of the engine depends on the care and restraint exercised during its early life. The general rules are as follows.

1. Keep to this break-in throttle position.







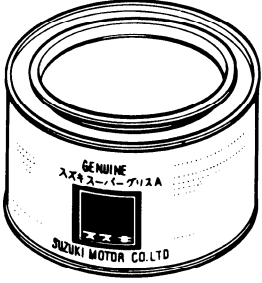
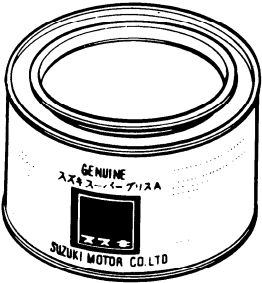
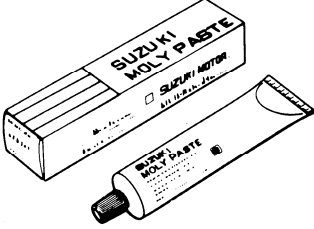
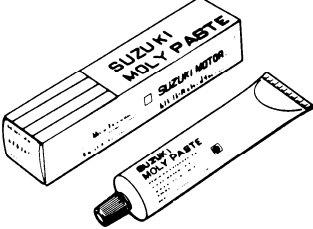
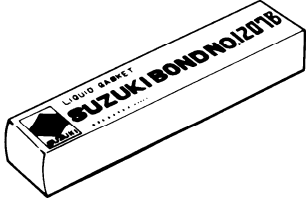
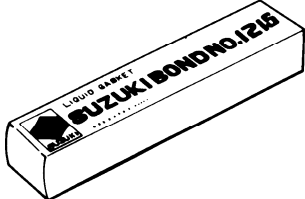

First 10 hours: Less than 1/2 throttle

2. After the engine has been operated for 10 hours the vehicle can be subjected to full throttle operation for short periods of time.







SPECIAL MATERIALS

The materials listed below are needed for maintenance work on the LT160E and should be kept on hand for ready use. These items supplement such standard materials as cleaning fluids, lubricant, emery cloth and the like. How to use them and where to use them are described in the text of this manual.

MATERIAL		PART	PAGE
For U.S.A. model	For other models		
 <p>SUZUKI SUPER GREASE "A" 99000-25030</p>	 <p>SUZUKI SUPER GREASE "A" 99000-25010</p>	<ul style="list-style-type: none"> ● Throttle cable and lever ● Front wheel hub bearing ● Steering shaft holder ● Rear axle housing bearing ● Oil seal ● Starter motor armature bearing ● Front brake camshaft ● King pin ● Front wheel hub dust seal ● Front brake dust seal ● Steering shaft dust seal ● Steering shaft lower busing ● Steering shaft lower dust seal ● Rear brake camshaft ● Rear brake drum cover dust seal ● Rear axle housing dust seal 	<p>2-17 2-17 6-16 2-17 6-16 2-17 6-23 3-36 5- 9 6- 7 6-16 6-16 6-16 6-16 6-16 6-16 6-23 6-23 6-23</p>
 <p>SUZUKI MOLY PASTE 99000-25140</p>	 <p>SUZUKI MOLY PASTE 99000-25140</p>	<ul style="list-style-type: none"> ● Rocker arm shafts ● Valve stem ● Piston pin ● Camshaft journal ● Cam chain tensioner push rod ● Starter motor armature end 	<p>3-48 3-49 3-16 3-22 3-45 3-65 5- 9</p>
 <p>SUZUKI BOND NO. 1207B 99104-31140</p>	 <p>SUZUKI BOND NO. 1215 99000-31110</p>	<ul style="list-style-type: none"> ● Cylinder head cover ● Magneto grommet ● Right crankcase ● Front brake plate 	<p>2- 3 3-48 3-32 3-39 6- 7</p>

MATERIAL		PART	PAGE
For U.S.A. model	For other models		
 <p>THREAD LOCK SUPER "1303" 99000-32030</p>	 <p>THREAD LOCK SUPER "1303" 99000-32030</p>	<ul style="list-style-type: none"> ● Starter clutch bolt ● Cam sprocket bolt 	<p>3-31 3-47</p>
 <p>THREAD LOCK SUPER "1303" 99000-32030</p>	 <p>THREAD LOCK SUPER "1305" 99000-32100</p>	<ul style="list-style-type: none"> ● Clutch shoe nut ● Magneto rotor nut ● Rear axle nut (L) 	<p>3-42 3-44 6-23</p>
 <p>THREAD LOCK SUPER "1303" 99000-32030</p>	 <p>THREAD LOCK SUPER "1322" 99000-32110</p>	<ul style="list-style-type: none"> ● Cam guide and pawl lifter mounting screw ● Rear sprocket guard nut 	<p>3-39 6-24</p>
 <p>THREAD LOCK SUPER "1303" 99000-32030</p>	 <p>THREAD LOCK SUPER "1324" 99000-32120</p>	<ul style="list-style-type: none"> ● Rear axle nut and lock nut (R) 	<p>6-23</p>

1-5 GENERAL INFORMATION

MATERIAL		PART	PAGE
For U.S.A. model	For other models		
 <p>THREAD LOCK SUPER "1333B" 99000-32020</p>	 <p>THREAD LOCK SUPER "1333B" 99000-32020</p>	<ul style="list-style-type: none"> ● 2nd drive gear 	3-35
 <p>THREAD LOCK SUPER "1333B" 99000-32020</p>	 <p>THREAD LOCK SUPER "1322" 99000-32110</p>	<ul style="list-style-type: none"> ● Knuckle arm grease nipple 	6-16
 <p>THREAD LOCK "1342" 99000-32050</p>	 <p>THREAD LOCK "1342" 99000-32050</p>	<ul style="list-style-type: none"> ● Magneto stator ● Oil pump mounting screws ● Starter motor housing screws ● Handlebar balancer screw 	3-32 5- 1 3-40 5- 9 6-10

PRECAUTIONS AND GENERAL INSTRUCTIONS

Observe the following items without fail when disassembling and reassembling vehicles.

- Do not run engine indoors with little or no ventilation.
- Be sure to replace packings, gaskets, circlips, O-rings and cotter pins with new ones.

CAUTION:

Never reuse a circlip. After a circlip has been removed from a shaft, it should be discarded and a new circlip must be installed.

When installing a new circlip, care must be taken not to expand the end gap larger than required to slip the circlip over the shaft.

After installing a circlip, always insure that it is completely seated in its groove and securely fitted.

- Tighten bolts and nuts from the ones of larger diameter to those of smaller diameter, and from inside to outside diagonally, to the specified tightening torque.
- Use special tools where specified.
- Use specified genuine parts and recommended oils.
- When more than 2 persons perform work together, pay attention to the safety of each other.
- After the reassembly, check parts for tightness and operation.
- Treat gasoline, which is extremely flammable and highly explosive, with greatest care. Never use gasoline as cleaning solvent.

Warning, Caution and Note are included in this manual occasionally, describing the following contents.

WARNING **The personal safety of the rider or bystanders may be involved. Disregarding this information could result in personal injury.**

CAUTION **These instructions point out special service procedures or precautions that must be followed to avoid damaging the machine.**

NOTE *This provides special information to make maintenance easier or important instructions clearer.*

REPLACEMENT PARTS

When you replace any parts, use only genuine SUZUKI replacement parts, or their equivalent. Genuine SUZUKI parts are high quality parts which are designed and built specifically for SUZUKI vehicles.

CAUTION:

Use of replacement parts which are not equivalent in quality to genuine SUZUKI parts can lead to performance problems and damage.

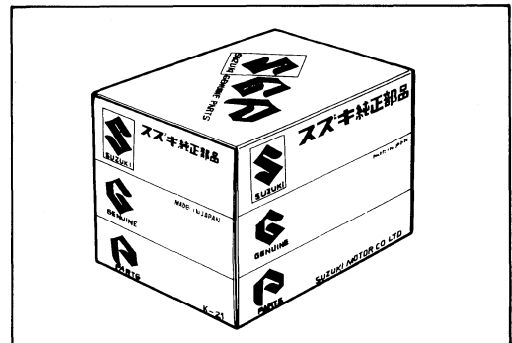

SPECIFICATIONS

DIMENSIONS AND DRY MASS

Overall length	1 605 mm (63.2 in)
Overall width	985 mm (38.8 in)
Overall height	1 000 mm (39.4 in)
Wheelbase	1 070 mm (42.1 in)
Ground clearance	135 mm (5.3 in)
Front track	730 mm (28.7 in)
Rear track	730 mm (28.7 in)
Seat height	725 mm (28.5 in)
Dry mass	152 kg (335 lbs)

ENGINE

Type	Four-stroke, air-cooled, OHC
Number of cylinders	1
Bore	58.0 mm (2.283 in)
Stroke	60.0 mm (2.362 in)
Piston displacement	158 cm ³ (9.6 cu. in)
Compression ratio	9.2 : 1
Carburetor	MIKUNI VM20SS
Air cleaner	Polyurethane foam element
Starter system	Electric
Lubrication system	Wet sump

TRANSMISSION

Clutch	Wet multi-plate auto- matic, centrifugal type
Transmission	5-speed constant mesh, 1-reverse
Gearshift pattern,	
Forward	All-up, foot lever operated
Reverse	Hand lever operated
Primary reduction	3.736 (71/19)
Final reduction	3.545 (39/11)
Gear ratio, Low	3.166 (38/12)
2nd	2.142 (30/14)
3rd	1.588 (27/17)
4th	1.200 (24/20)
Top	0.950 (19/20)
Reverse	2.833 (34/12)
Drive chain	DAIDO D.I.D. 520VS or TAKASAGO RK520SM, 84 links

CHASSIS

Front suspension	Independent, swing axle, coil spring, oil damped
Rear suspension	Swingarm coil spring, oil damped, spring preload 5-way adjustable
Steering angle	41° (Inside) 30° (Outside)
Caster	8°
Trail	31 mm (1.2 in)
Toe-in	3–11 mm (0.1–0.4 in)
Turning radius	2.4 m (7.9 ft)
Front brake	Internal expanding
Rear brake	Internal expanding
Front tire size	AT20 x 7-8☆
Rear tire size	AT22 x 10-8☆
Front wheel travel	80 mm (3.1 in)
Rear wheel travel	90 mm (3.5 in)

ELECTRICAL

Ignition type	SUZUKI "PEI"
Ignition timing	10° B.T.D.C. below 1 000 r/min and 30° B.T.D.C. above 5 000 r/min
Spark plug	NGK D7EA or CHAM- PION A8YC . . U.K. and U.S.A. NGK DR7EA or CHAM- PION RA8YC . . Others
Battery	12V 32.4 kC (9Ah)/10HR
Generator	Flywheel magneto
Fuse	15A

CAPACITIES

Fuel tank	
Including reserve	8.5 L (2.2/1.9 US/Imp gal)
reserve	1.1 L (1.2/1.0 US/Imp qt)
Engine oil,	
oil change	1 500 ml (1.6/1.3 US/Imp qt)
filter change	1 700 ml (1.8/1.5 US/Imp qt)

These specifications are subject to change without notice.

PERIODIC MAINTENANCE AND TUNE-UP PROCEDURES

CONTENTS

PERIODIC MAINTENANCE SCHEDULE	2- 1
MAINTENANCE PROCEDURES	2- 2
BATTERY	2- 2
ENGINE NUTS AND BOLT	2- 3
VALVE CLEARANCE	2- 4
CAMSHAFT DRIVE CHAIN	2- 5
SPARK PLUG	2- 5
ENGINE IDLE SPEED	2- 6
THROTTLE CABLE	2- 6
FUEL LINE	2- 7
SPARK ARRESTER	2- 7
ENGINE OIL AND OIL FILTER	2- 7
AIR CLEANER	2- 9
CLUTCH	2-10
DRIVE CHAIN	2-10
SPROCKETS	2-12
TIRES	2-12
BRAKES	2-13
STEERING	2-14
SUSPENSION	2-14
CHASSIS BOLTS AND NUTS	2-15
GENERAL LUBRICATIONS	2-17

PERIODIC MAINTENANCE SCHEDULE

The chart below lists the recommended intervals for all the required periodic service work necessary to keep the vehicle operating at peak performance and economy. Mileages are expressed in terms of kilometers (miles).

NOTE:

More frequent servicing may be performed on vehicles that are used under severe conditions.

PERIODIC MAINTENANCE CHART

ENGINE AND CHASSIS

ITEM	INTERVAL		
	Initial 1 month	Every 3 months	Every 6 months
Battery (Specific gravity of electrolyte)	I	I	—
Engine nuts and bolt	T	T	—
Valve clearance	I	I	—
Camshaft drive chain tensioner	I	I	—
Spark plug	—	I	—
	Replace every 18 months		
Engine idle speed	I	—	I
Throttle cable	I	—	I
Fuel line	—	I	—
	Replace every 4 years		
Spark arrester	—	—	C
Engine oil and filter	R	R	—
Air cleaner	—	C	—
Clutch	I	—	I
Drive chain	Inspect every month		
Sprockets	I	I	—
Tires	Inspect every month		
Brakes	I	I	—
Steering	I	I	—
Suspension	—	—	I
Chassis nuts and bolts	T	T	—
General lubrications	—	L	—

NOTE: T = Tighten, R = Replace, C = Clean, L = Lubricate

I = Inspect and clean, adjust, replace or lubricates as necessary

MAINTENANCE PROCEDURES

This section describes the service procedures for each section of Periodic Maintenance.

BATTERY

Inspect at Initial 1 month and Every 3 months.

- Remove the headlight housing. (Refer to page 6-1.)
- Remove the indicator panel. (Refer to page 6-1.)
- Remove the battery cover. (Refer to page 6-1.)
- Remove the battery \ominus and \oplus lead wires, and remove the battery.
- Check level and specific gravity of electrolyte. Add distilled water, if necessary, to keep the surface of the electrolyte above the LOWER level line and below the UPPER level line. To determine state of charge, check specific gravity with a hydrometer.

09900-28403: Hydrometer

Standard specific gravity: 1.28 at 20° C (68° F)

A specific gravity reading of 1.22 (at 20° C) or under means that the battery needs recharging.

CAUTION:

Do not charge the battery while connected to the vehicle. Charging the battery while connected into the circuit may damage the regulator/rectifier or other components.

- Confirm that the battery breather hose is routed properly, as shown in the illustration and that it is not kinked or pinched.

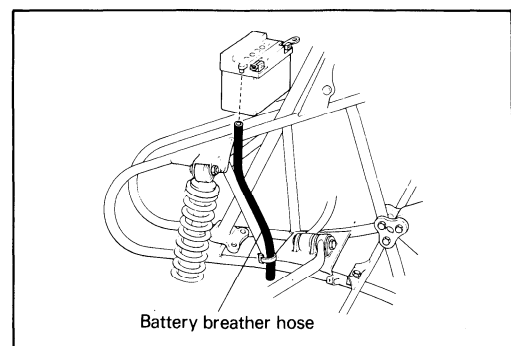
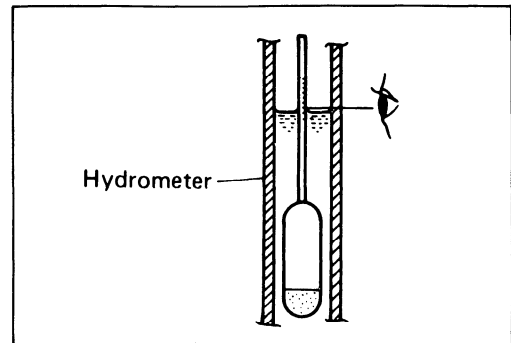
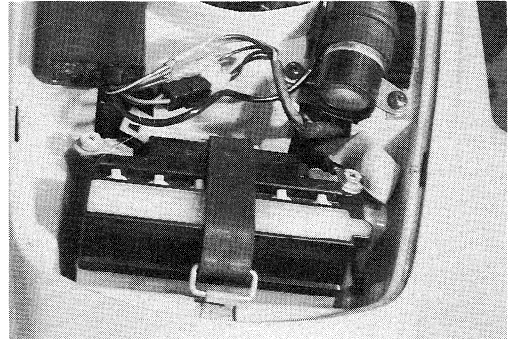

ENGINE NUTS AND BOLT

Tighten at Initial 1 month and Every 3 months

CYLINDER HEAD NUTS

- Remove the seat and front fender. (Refer to page 6-1.)
- Remove the cylinder head cover. (Refer to page 3-8.)
- First loosen and retighten the four 8-mm nuts ① and two 6-mm nuts ② to the specified torque with a torque wrench, when engine is cold.

Tightening torque

Item	N·m	kg·m	lb·ft
8 mm nut: ①	21 – 25	2.1 – 2.5	15.0 – 18.0
6 mm nut: ②	7 – 11	0.7 – 1.1	5.0 – 8.0

- When installing the cylinder head cover, apply SUZUKI Bond No. 1207B/1215 to the mating surface. (Refer to page 3-48.)

99104-31140: SUZUKI Bond No. 1207B (For U.S.A.)

99000-31110: SUZUKI Bond No. 1215 (For others)

CYLINDER BASE NUTS

- Tighten the two 6-mm nuts ③ to the specified torque.

Tightening torque: 7 – 11 N·m
(0.7 – 1.1 kg·m, 5.0 – 8.0 lb·ft)

EXHAUST PIPE NUTS AND MUFFLER BOLT

- Tighten the exhaust pipe nuts, and muffler mounting bolt to the specified torque.

Tightening torque

Item	N·m	kg·m	lb·ft
Exhaust pipe nut ④	9 – 12	0.9 – 1.2	6.5 – 8.5
Muffler mounting bolt ⑤	18 – 28	1.8 – 2.8	13.0 – 20.0

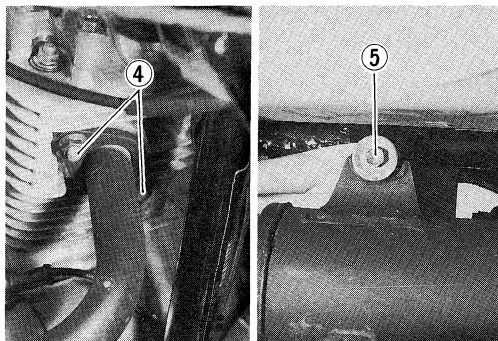
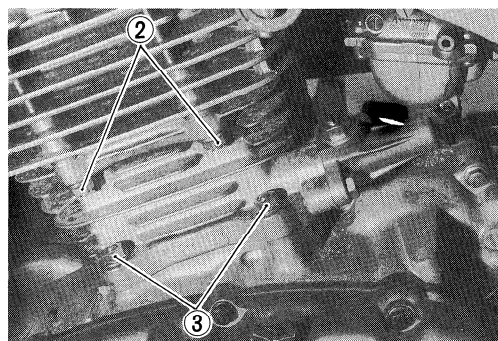
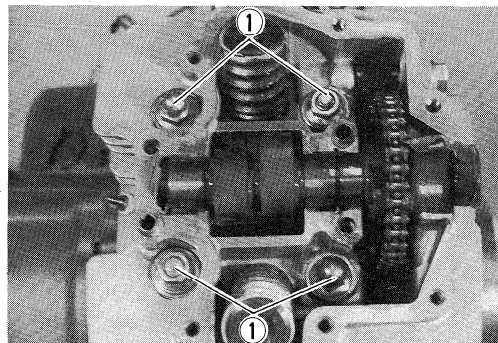

VALVE CLEARANCE

Inspect at Initial 1 month and Every 3 months

Excessive valve clearance results in valve noise and insufficient valve clearance results in valve damage and reduced power. At the distances indicated above, check and adjust the clearance to the specification.

Valve clearance specifications

IN : 0.03 – 0.08 mm (0.001 – 0.003 in)

EX: 0.05 – 0.10 mm (0.002 – 0.004 in)

The procedure for adjusting the valve clearance is as follows:

NOTE:

Valve clearance is to be checked when the engine is cold. Both the intake and exhaust valves must be checked and adjusted when the piston is at Top-Dead-Center (TDC) of the compression stroke.

- Remove the seat and front fender. (Refer to page 6-1.)
- Remove the fuel tank. (Refer to page 3-4.)
- Remove the spark plug and valve inspection caps ①.
- Drain engine oil. (Refer to page 2-7.)
- Remove the gearshift lever and reverse cable guide. (Refer to page 3-5.)
- Remove the magneto cover.
- Rotate the magneto rotor to set the piston at (TDC) of the compression stroke. (Rotate the rotor until the "T" line ② on the rotor is aligned with the index mark ③.)
- Insert the thickness gauge into the clearance between the valve stem end and the adjusting screw on the rocker arm.

09900-20803: Thickness gauge

- If clearance is off the specification, bring it into the specified range with a screw driver and box end wrench.
- Reinstall the spark plug, valve inspection caps, magneto cover, gearshift lever and reverse cable holder.

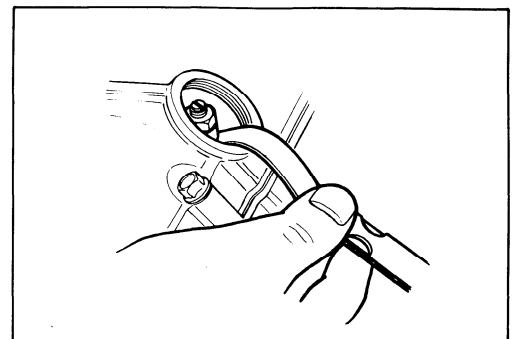
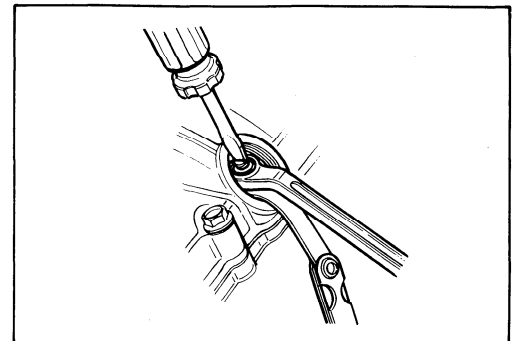
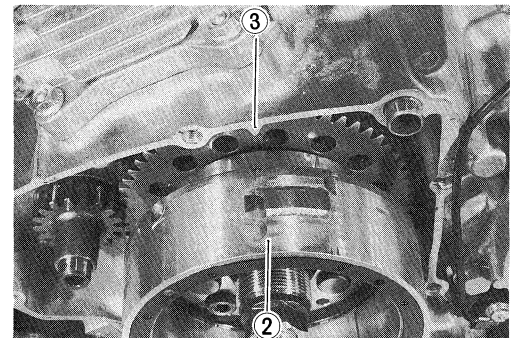
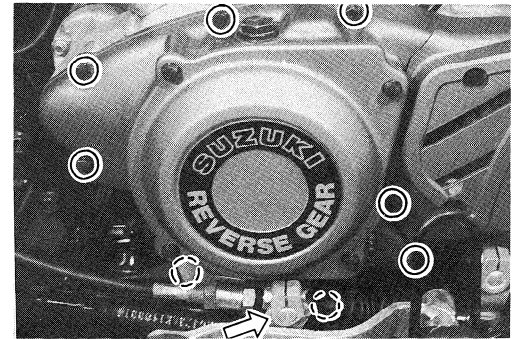
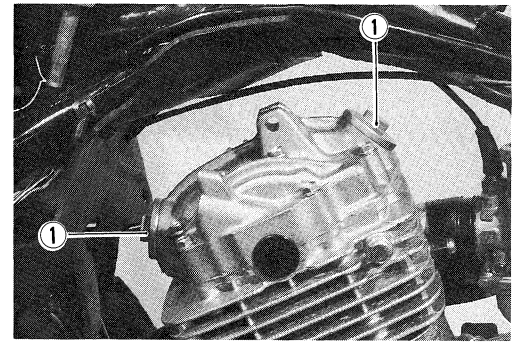

CAMSHAFT DRIVE CHAIN TENSIONER

Inspect at Initial 1 month and Every 3 months.

The cam drive chain is maintained at the proper tension by a manually adjusted tensioner. To prevent chain noise and fluctuating valve timing, the tensioner must be adjusted at the distance listed above.

The procedure for adjusting the cam chain tensioner is as follows:

- Position must be at top dead center on compression stroke. (Refer to page 2-4.)
- Loosen lock nut ① on the chain adjuster and back out set screw ② one turn. This will allow a spring to push the tensioner push rod firmly onto the cam chain tensioner, taking up any slack that may have existed.
- Tighten set screw ② to lock the tensioner push rod in position and tighten lock nut ① to secure the set screw.

NOTE:

If the cam chain is noisy after having been adjusted, the tensioner push rod is probably sticking. Remove the adjuster, and clean and lubricate the push rod to obtain smooth movement and proper tensioning action.

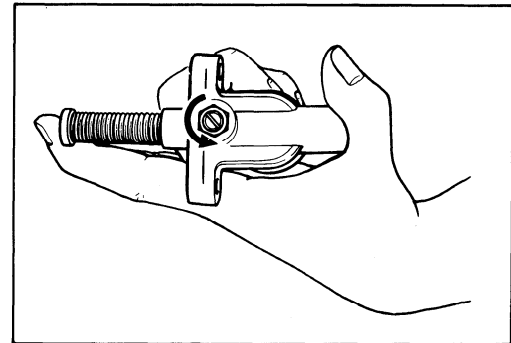
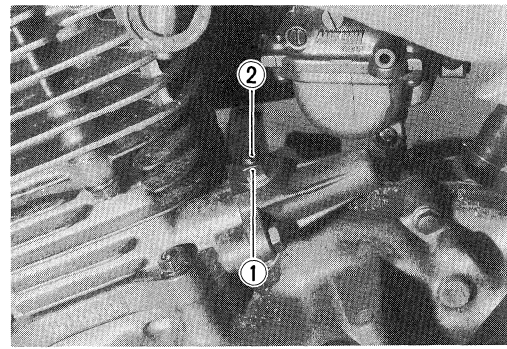

SPARK PLUG

Clean Every 3 months and Replace Every 18 months

Remove the carbon deposits with a wire or pin and adjust the spark plug gap to 0.6 – 0.7 mm (0.024 – 0.028 in), measuring with a thickness gauge.

When removing carbon deposits, be sure to observe the appearance of the plug, noting the color of the carbon deposits. The color observed indicates whether the standard plug is suitable or not.

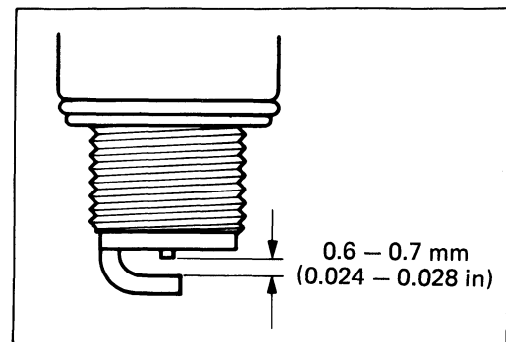

	NGK	CHAMPION	NOTE
Standard	D7EA	A8YC	U.K. and U.S.A.
	DR7EA	RA8YC	The others

“R” type spark plug

NOTE:

An “R” type spark plug is installed for some specifications. An “R” type spark plug has a resistor located at the center electrode to prevent radio noise.

ENGINE IDLE SPEED

Inspect at Initial 1 month and Every 6 months

IDLING ADJUSTMENT

NOTE:

Make this adjustment when the engine is hot.

- Turn in the pilot screw ① until it bottoms.

NOTE:

Be careful not to overtighten the screw.

- From that position, turn out the pilot screw 2 turns.
- Connect a tachometer.
- Start up the engine and set its speed between 1 450 and 1 550 r/min by turning throttle stop screw ②.
- Turn in or out the pilot screw within 1/2 turn from the standard setting, and set it when the engine speed is at the highest possible level.
- After this adjustment, recheck the idling speed and adjust to between 1 450 and 1 550 r/min with throttle stop adjusting screw if necessary.

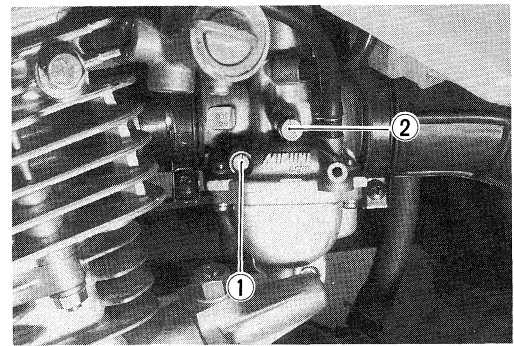

THROTTLE CABLE

Inspect at initial 1 month and Every 6 months

THROTTLE CABLE PLAY

Adjust the throttle cable play as follows.

- Loosen the lock nut ③.
- Turn the adjuster ④ in or out to obtain the correct play.

Throttle cable play ① : 0.5 – 1.0 mm (0.02 – 0.04 in)

- After adjusting the play, tighten the lock nut.

CHOKE CABLE PLAY

- Loosen the lock nut ⑤.
- Turn the adjuster ⑥ in or out to obtain the correct play.

Choke cable play ② : 0.5 – 1.0 mm (0.02 – 0.04 in)

- After adjusting the play, tighten the lock nut ⑤.

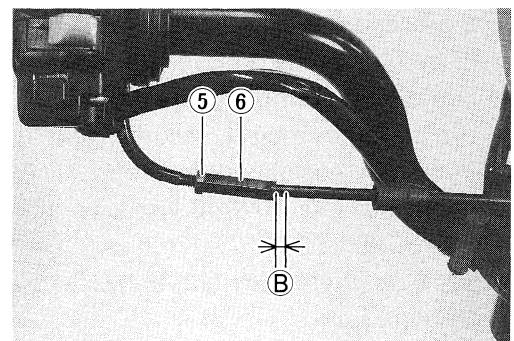
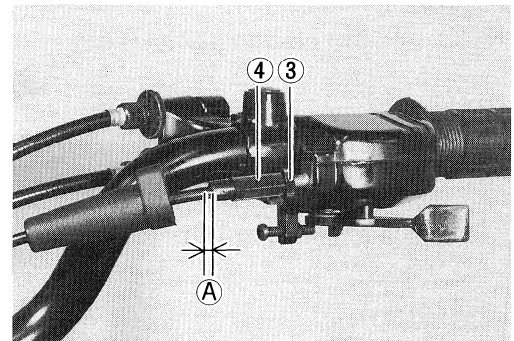

FUEL LINE

Inspect Every 3 months
Replace Every 4 years.

Inspect the fuel line for damage and fuel leakage. If any defects are found, the fuel line must be replaced.

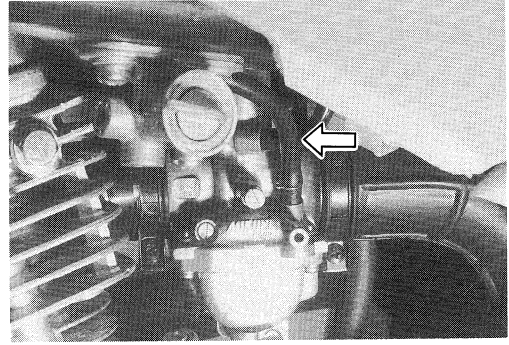

SPARK ARRESTER

Clean Every 6 months

The procedure is as follows:

- Shift into neutral position and set the parking brake.
- Remove the drain bolts ①.
- Start the engine and rev it to blow out the accumulated carbon particles.
- Stop the engine, and replace the drain bolts ① and tighten it securely.

WARNING:

Only clean the spark arrester in an open area away from combustible materials.

Exhausted hot carbon particles can start a fire.

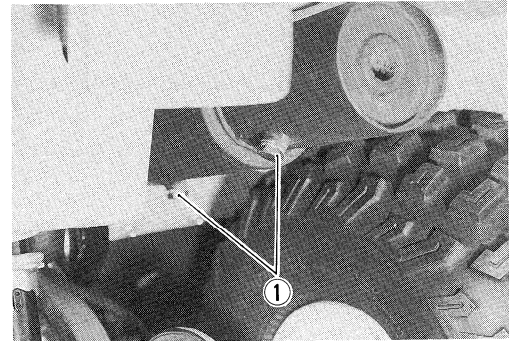

ENGINE OIL AND OIL FILTER

Replace (change) at Initial 1 month and Every 3 months

ENGINE OIL

The oil should be changed with the engine hot.

The procedure is as follows:

- Place the vehicle on level ground.
- Drain oil by removing the drain plug ② and filler cap ③.
- Fit the drain plug ② securely and add fresh oil through the filler. The engine will hold about 1 500 ml (1.6/1.3 US/Imp qt) of oil. Use 10W/40 viscosity of oil under API classification of SE or SF.
- Start up the engine and allow it to run for several seconds at idling speed.
- Shut down the engine and wait about one minute. Then check the oil level in the oil level window ④. The vehicle must be in a level, upright position for accurate measurement. If the level is below the upper line, add oil until the level reaches the upper line.

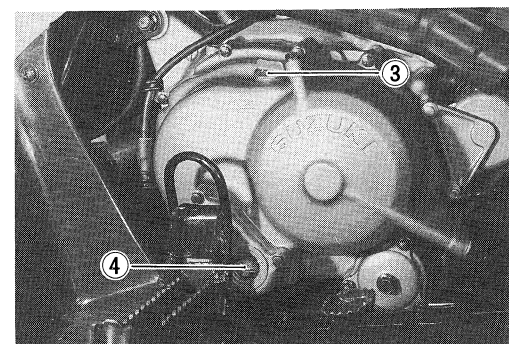
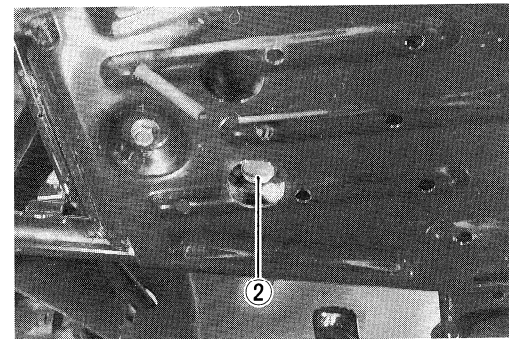

ENGINE OIL FILTER

Replace the oil filter in the following manner:

- Drain the engine oil by removing the drain plug and filler cap.
- Remove the oil filter cap by removing the three nuts.
- Remove the oil filter.
- Replace the oil filter ① with a new one.
- Before putting on the oil filter cap, check to be sure that the spring ② and a new O-ring ③ are installed correctly.

NOTE:

Be sure that the O-ring ④ behind the filter is in position.

- Install a new O-ring to the filter cap and replace the oil filter cap and tighten the nuts securely.
- Pour in engine oil and check the level.

NOTE:

Pour about 1 700 ml (1.8/1.5 US/Imp qt) of engine oil into the engine only when changing oil and replacing oil filter at the same time. When performing engine overhaul, the amount of oil to be replenished is 1 900 ml (2.0/1.8 US/Imp qt).

CAUTION:

When reassembling the oil filter, make sure to check the oil filter installed as shown above. If the filter is installed improperly, serious engine damage may result.

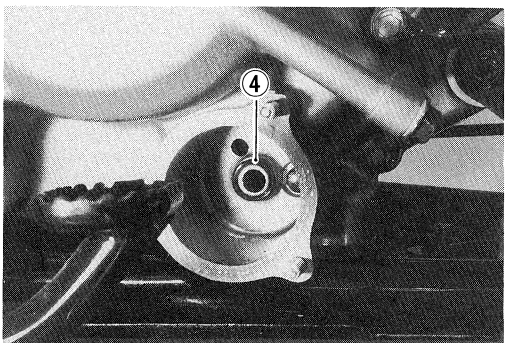
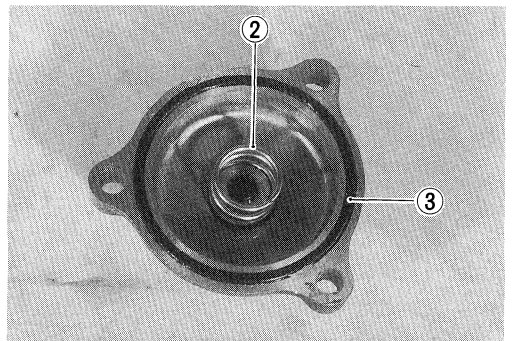
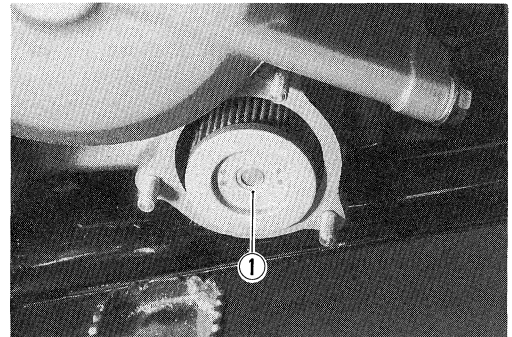
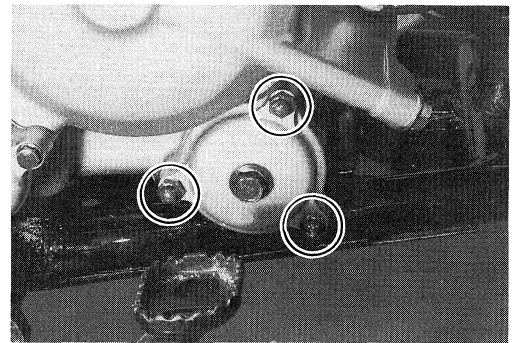

AIR CLEANER

Clean and oil Every 3 months

If the air cleaner is clogged with dust, intake resistance will be increased with a resultant decrease in power output and an increase in fuel consumption.

Check and clean the element in the following manner.

- Remove the seat.
- Remove the air cleaner case cover by removing the screws ①.
- Remove the air cleaner element ② by removing the pin ③.
- Remove the polyurethane foam element ④ from the element frame ⑤.
- Fill a washing pan of a proper size with non-flammable cleaning solvent. Immerse the element in the cleaning solvent and wash it clean.
- Squeeze the cleaning solvent out of the washed element by pressing it between the palms of both hands.
- Immerse the element in motor oil, and squeeze the oil out of the element leaving it slightly wet with oil.

NOTE:

Do not twist or wring the element because it will tear or the individual cells of the element will be damaged.

CAUTION:

Inspect the element carefully for rips, torn seams, etc. If any damage is noted, replace the element.

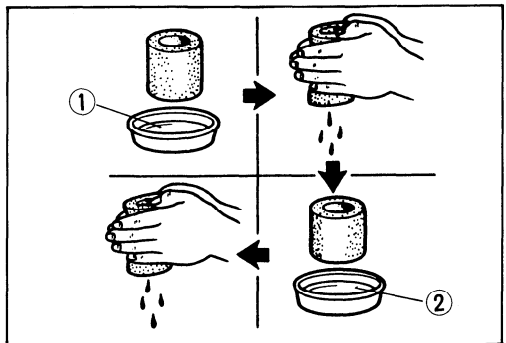
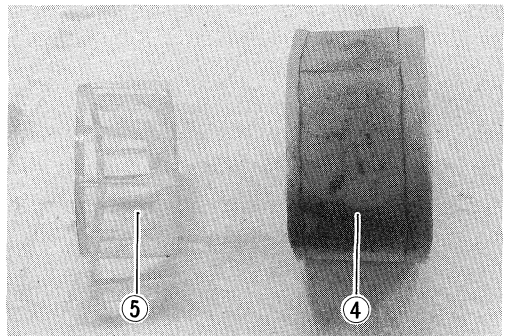
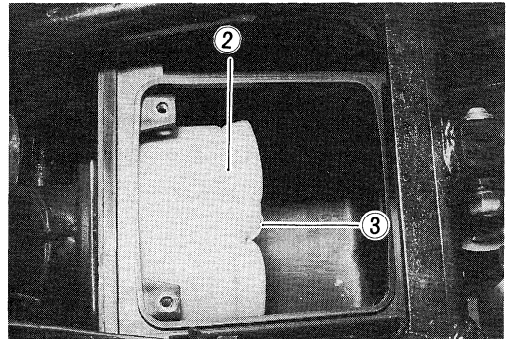
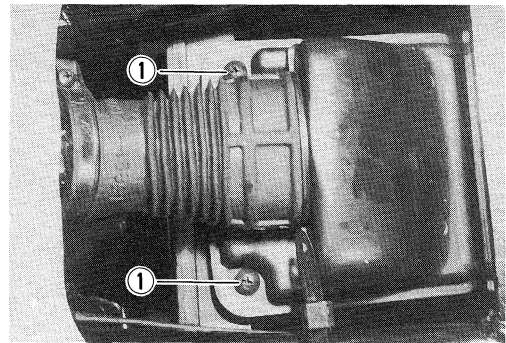

- ① Non-flammable cleaning solvent
- ② SAE 10W/40 OIL

CLUTCH

Inspect at Initial 1 month and Every 6 months

- Drain engine oil. (Refer to page 2-7.)
 - Remove the right side footrest.
 - Remove the three bolts and remove the clutch adjuster cap.
-
- Loosen the lock nut ①.
 - First tighten the release screw ② 1/2 rotation and loosen it until resistance is felt.
 - From that position, tighten the release screw 1/8 rotation, and tighten the lock nut.
 - Install a new gasket and the clutch adjuster cap properly.
 - Refill engine with proper amount of oil. (Refer to page 2-7.)

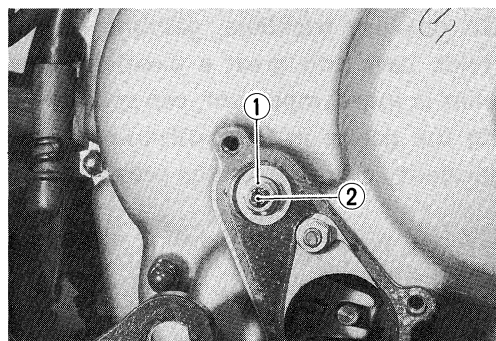
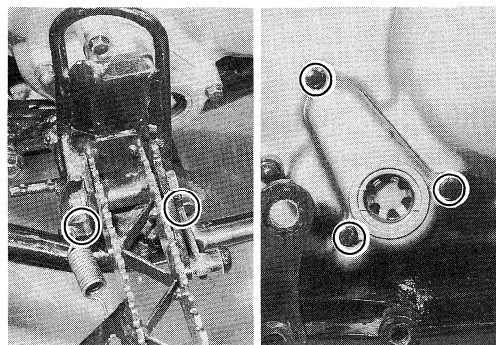

DRIVE CHAIN

Inspect Every month

Visually inspect the drive chain for the below-listed possible malconditions. (Lift the rear wheels and place a jack or block under the frame, and turn the rear wheels slowly by hand, with the transmission in NEUTRAL.)

- * Loose pins
- * Damaged rollers
- * Dry or rusted links
- * Kinked or binding links
- * Excessive wear
- * Missing O-ring or seals

If any defects are found, the drive chain must be replaced.

CHECKING

- Place the vehicle on level ground.
- Loosen the axle housing mounting bolts ③ and nuts ④, and chain adjuster lock nut ⑤.
- Remove the rear fender. (Refer to page 6-3.)
- Tense the drive chain fully by turning the chain adjusters ⑥.
- Count out 21 pins (20-pitch) on the chain and measure the distance between the two. If the distance exceeds the following limit, the chain must be replaced.

Service Limit: 319.4 mm (12.57 in)

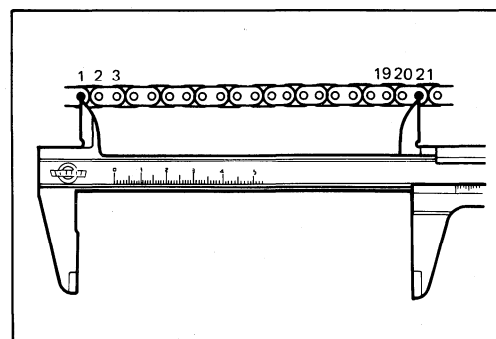
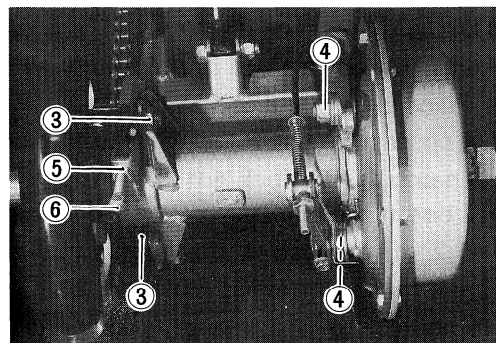
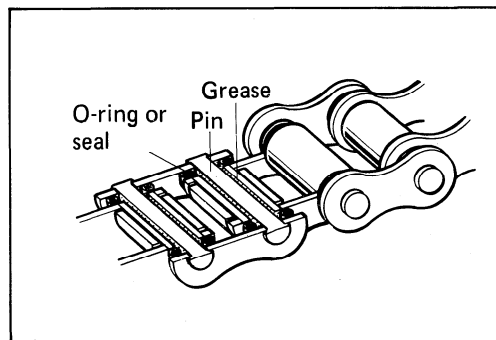

CAUTION:

The standard drive chain is DAIDO DID520V or TAKASAGO RK520SM. SUZUKI recommends that the above-mentioned standard drive chain be used for the replacement.

CLEANING AND LUBRICATING

- Wash the chain with kerosene. If the chain tends to rust quickly, the intervals must be shortened.

CAUTION:

Do not use trichlene, gasoline or any similar fluids: These fluids have too great a dissolving power for this chain and, what is more important, can spoil the O-rings (or seals) confining the grease in the bush-to-pin clearance. Remember, high durability comes from the presence of grease in that clearance.

- After washing and drying the chain, oil it with a heavy-weight motor oil.

CAUTION:

Do not use any oil sold commercially as "drive chain oil". Such oil too can spoil the O-rings (or seals).

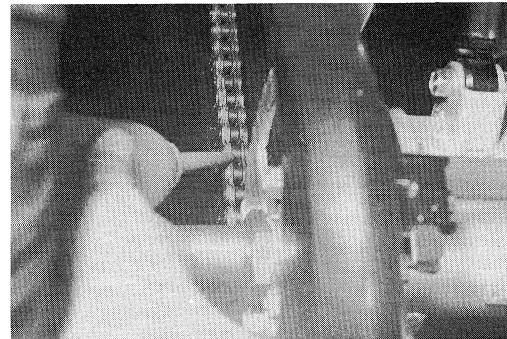
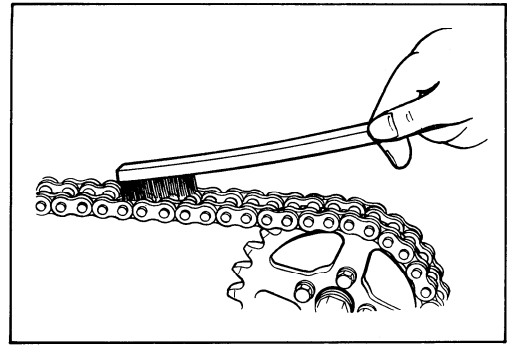

ADJUSTING

Adjust the drive chain in the following manner:

- Place the vehicle on level ground.
- Loosen the axle housing mounting bolts ① and nuts ②, and chain adjuster lock nut ③.
- Loosen the adjuster ④ until the chain has 20 – 30 mm (0.8 – 1.2 in) of slack at the middle between the engine sprocket and rear sprocket as shown in the illustration.

After adjusting the slack in the drive chain to 20 – 30 mm (0.8 – 1.2 in), tighten the nuts ①, ② and ③ to the specified torque and perform a final inspection.

Standard: 20 – 30 mm (0.8 – 1.2 in)

Tightening torque ①, ②: 70 – 100 N·m
(7.0 – 10.0 kg·m, 50.5 – 72.5 lb·ft)

③: 18 – 28 N·m
(1.8 – 2.8 kg·m, 13.0 – 20.0 lb·ft)

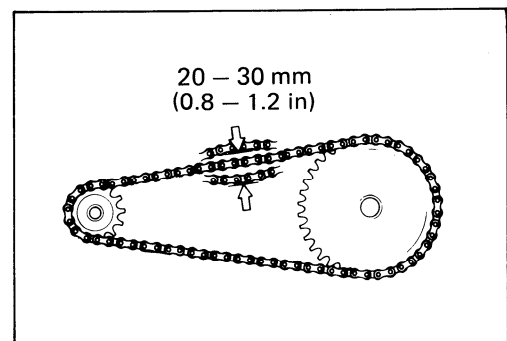
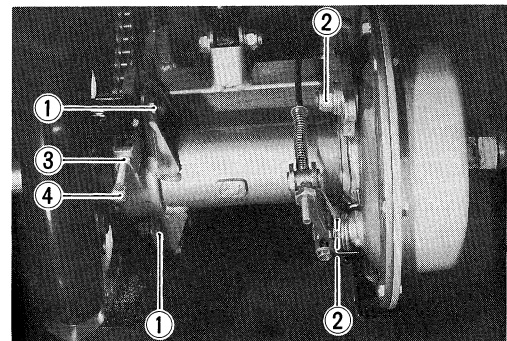

SPROCKETS

Inspect at Initial 1 month and Every 3 months

Inspect the engine sprocket and rear sprocket teeth for wear. If they are worn as illustrated, replace the sprocket and drive chain.

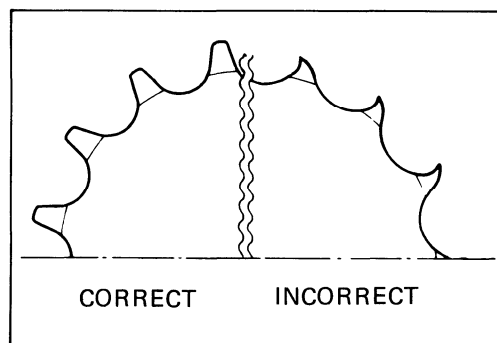

TIRES

Inspect Every month

Inspect the tires for wear and damage. Check the tire tread depth as shown. Replace a badly worn or damaged tire. A tire with its tread worn down to limit (in terms of tread depth) must be replaced.

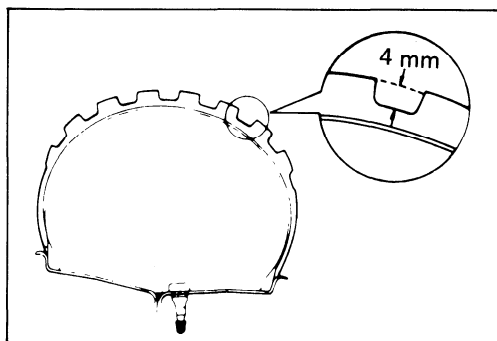

Tire tread depth

Service Limit: 4.0 mm (0.16 in)
(Front and Rear)

09900-20805: Tire depth gauge (Not available in U.S.A.)

Check the tire pressure, and examine the valve for evidence of air leakage.

Standard tire pressure

	LOAD CAPACITY	
	UP TO 80 kg (175 lbs)	80 – 130 kg (175 – 285 lbs)
FRONT	17.5 kPa (0.175 kg/cm ² , 2.5 psi)	25 kPa (0.25 kg/cm ² , 3.6 psi)
REAR	15 kPa (0.15 kg/cm ² , 2.2 psi)	20 kPa (0.20 kg/cm ² , 2.9 psi)

CAUTION:

To minimize the possibility of tire damage from overinflation, we strongly recommend that a manual type air pump be used rather than a high pressure tire filler as found in gas stations. When pumping air in, never exceed 70 kPa (0.7 kg/cm², 10 psi).

BRAKES

Inspect at Initial 1 month and Every 3 months

FRONT BRAKE ADJUSTMENT

Front brake lever distance **A** should be 30 mm (1.2 in) as measured the distance as shown in photo. when brake is fully applied. If the distance **A** in the brake is incorrect, adjust it in the following steps:

- Place the vehicle on level ground.
- Loosen the lock nuts **1** and screw the adjusters **2** on the brake lever holder all the way in.
- Remove the front fender. (Refer to page 6-1.)
- Loosen the right and left brake cable adjuster lock nuts **3**.
- Adjust the brake cable adjusters **4** to acquire the specified distance **A**.

NOTE:

Make sure that the inner cable holder **5** parallels the brake cable holder **6** while applying the front brake tightly.

- Lift up the front side of the vehicle with a jack or block.
- Check the right and left brake friction by turning both front wheels while slightly squeezing the front brake lever.
- If the right and left brake friction is not equal, turn the adjusters **2** in or out until the right and left brake friction makes equal.

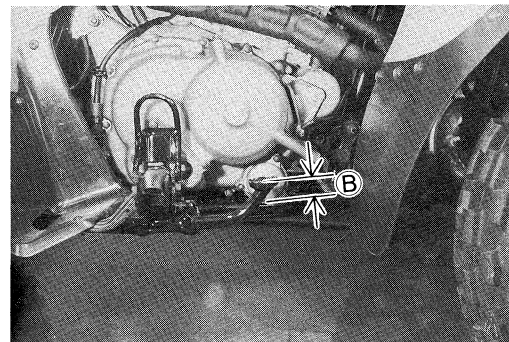
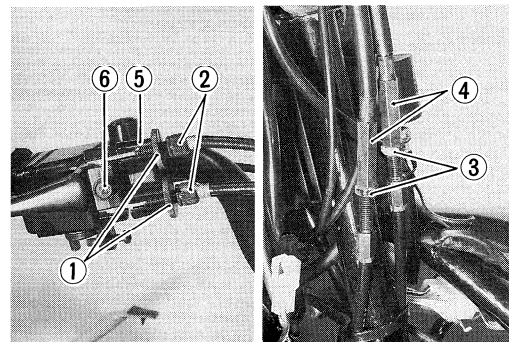
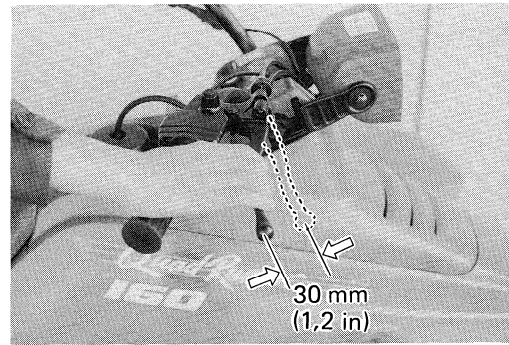

REAR BRAKE ADJUSTMENT

- Adjust the free travel **B** to 20 – 30 mm (0.8 – 1.2 in) by turning the brake adjusting nut **7** in or out.

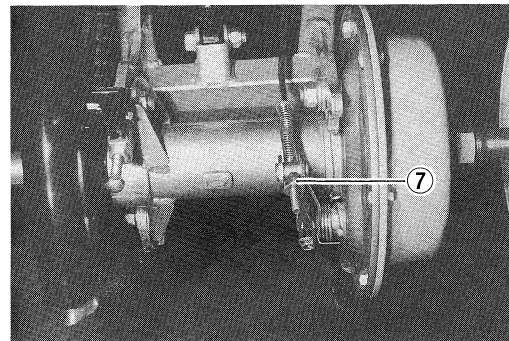

BRAKE LINING WEAR LIMIT

This vehicle is equipped with brake lining wear limit indicator on front and rear.

To check wear of the brake lining, perform the following steps.

- First check if the brake system is properly adjusted.
- While operating the brake, check to see that the wear limit indicator **8** is within the limit mark **9** on the steering knuckle and rear axle housing.

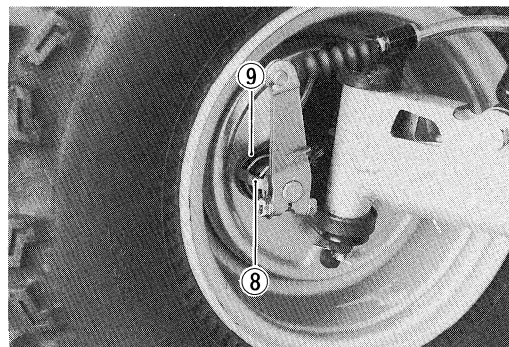

- If the index mark is beyond the range as shown in the illustration, the brake shoe assembly should be replaced with a new set of shoe.

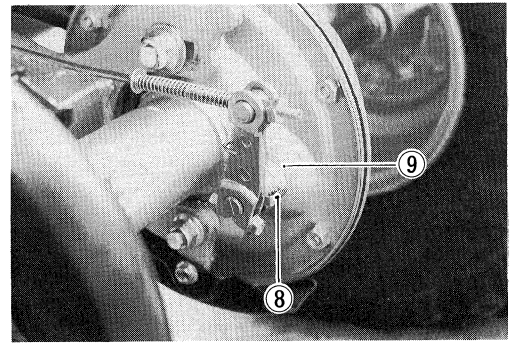

STEERING

Inspect at Initial 1 month and Every 3 months

Steering system should be adjusted properly for smooth manipulation of handlebar and safe running.

TOE-IN

- Place the vehicle on level ground.
- Make sure the tire pressure for both tires is the same and set to the proper specification.
- The front wheels are set in straightahead position.
- Mount 75 kg (165 lbs) load on the seat.
- Measure the distance (A and B in illustration) of front wheels with a toe-in gauge as shown in illustration and calculate the difference between A and B.

Toe-in: 3 – 11 mm (0.1 – 0.4 in)

- If the toe-in is off the specification, bring it into the specified range. (Refer to page 6-15.)

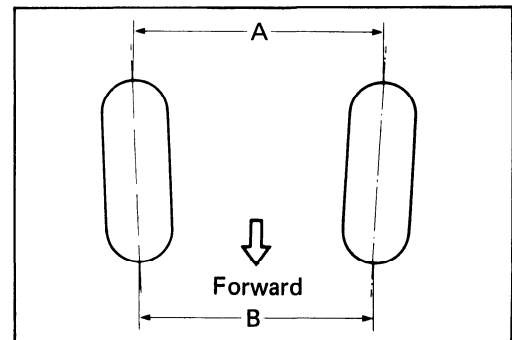
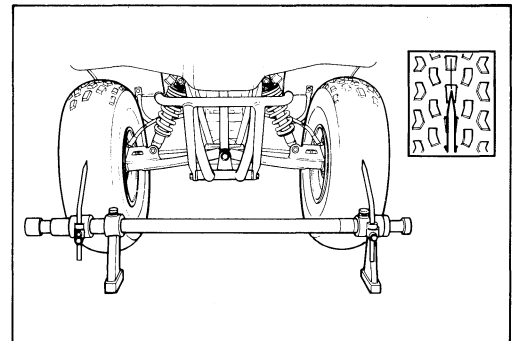

SUSPENSION

Inspect Every 6 months.

- Inspect the front and rear shock absorbers for oil leakage.
- Inspect the suspension arm for scratches or other damage.

CHASSIS NUTS AND BOLTS

Tighten at Initial 1 month and Every 3 months

The nuts and bolts listed below are important parts, and they must be in good condition for safety. They must be retightened, as necessary, to the specified torque with a torque wrench.

	Item	N·m	kg·m	lb·ft
①	Handlebar clamp bolt	18 – 28	1.8 – 2.8	13.0 – 20.0
②	Steering shaft holder bolt	18 – 28	1.8 – 2.8	13.0 – 20.0
③	Front wheel set nut	20 – 31	2.0 – 3.1	14.5 – 22.5
④	Front wheel hub nut	50 – 80	5.0 – 8.0	36.0 – 58.0
⑤	Tie-rod lock nut	22 – 35	2.2 – 3.5	16.0 – 25.5
⑥	Tie-rod end nut	22 – 35	2.2 – 3.5	16.0 – 25.5
⑦	Front shock absorber nut (Upper & Lower)	40 – 60	4.0 – 6.0	29.0 – 43.5
⑧	Front suspension arm nut	55 – 77	5.5 – 7.7	40.0 – 55.5
⑨	Knuckle arm nut	40 – 60	4.0 – 6.0	29.0 – 43.5
⑩	Steering shaft lower nut	22 – 35	2.2 – 3.5	16.0 – 25.5
⑪	Footrest bolt	55 – 77	5.5 – 7.7	40.0 – 55.5
⑫	Front brake cam lever nut	9 – 13	0.9 – 1.3	6.5 – 9.5
⑬	Rear swingarm pivot shaft nut	50 – 80	5.0 – 8.0	36.0 – 58.0
⑭	Rear wheel hub nut	85 – 115	8.5 – 11.5	61.5 – 83.0
⑮	Rear wheel set nut	44 – 66	4.4 – 6.6	32.0 – 47.5
⑯	Rear axle nut and lock nut	160 – 200	16.0 – 20.0	115.5 – 144.5
⑰	Rear shock absorber nut (Upper & Lower)	40 – 60	4.0 – 6.0	29.0 – 43.5
⑱	Rear brake cam lever nut	9 – 13	0.9 – 1.3	6.5 – 9.5
⑲	Rear brake pedal bolt	20 – 31	2.0 – 3.1	14.5 – 22.5
⑳	Rear axle housing mounting bolt and nut	70 – 100	7.0 – 10.0	50.5 – 72.5
㉑	Rear sprocket nut	48 – 72	4.8 – 7.2	34.5 – 52.0

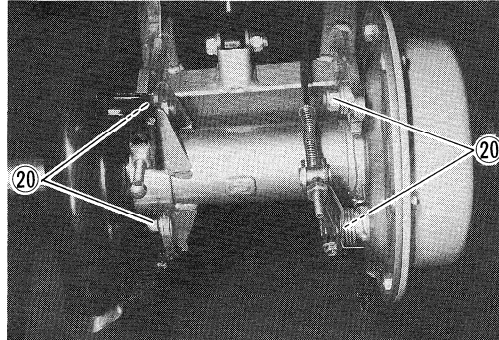
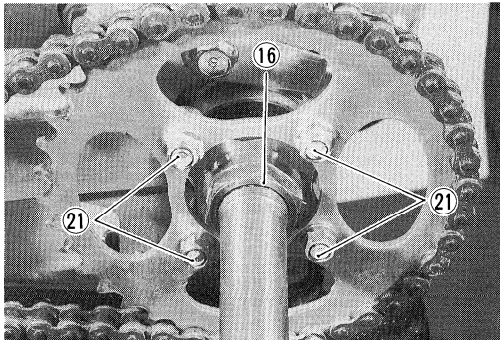

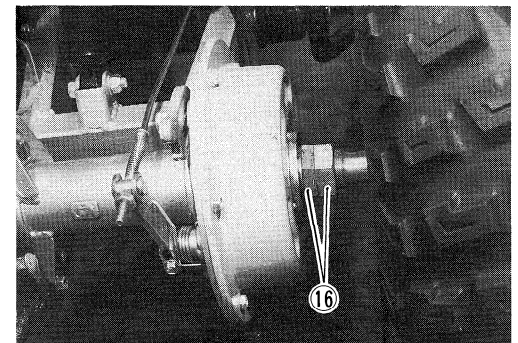
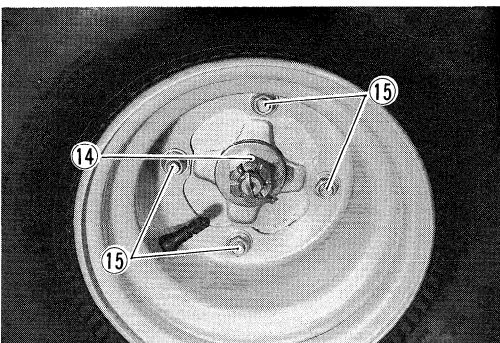
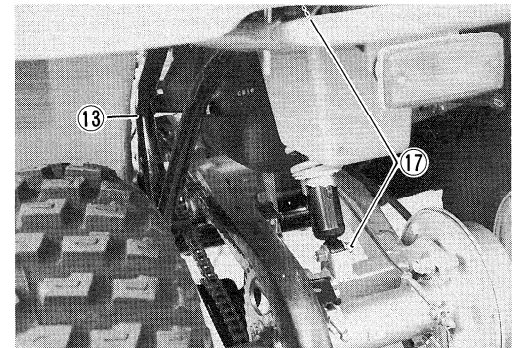
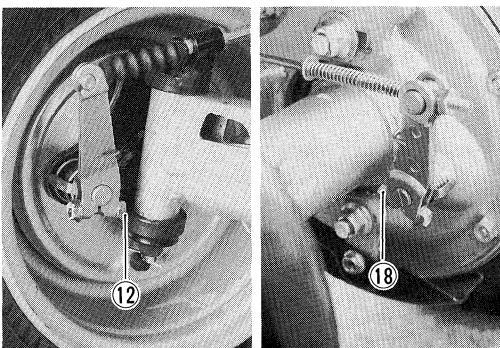
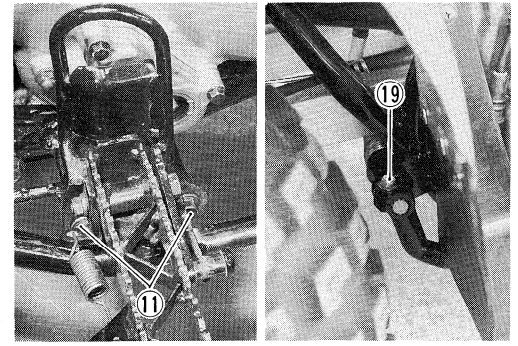
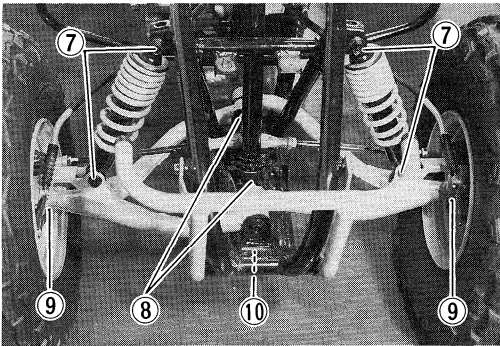
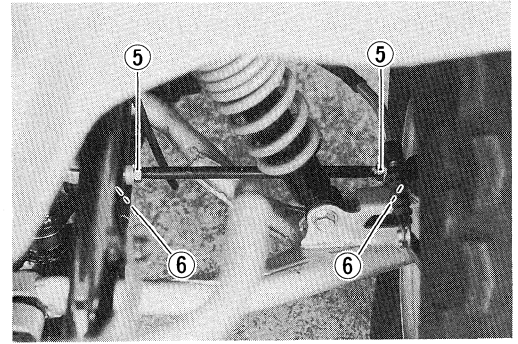
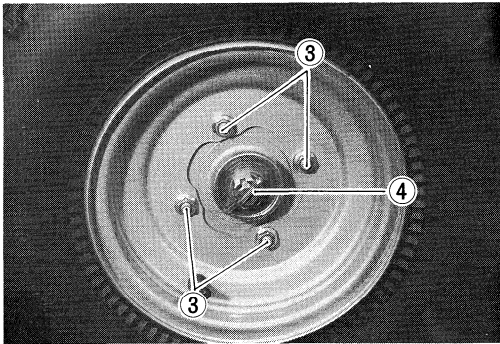
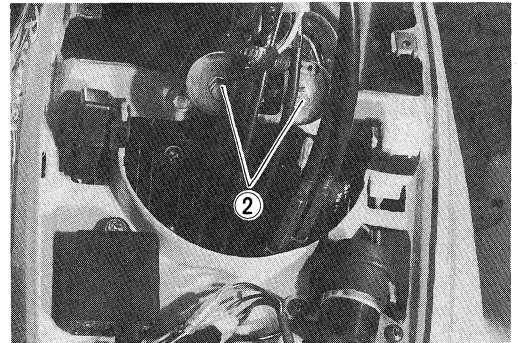
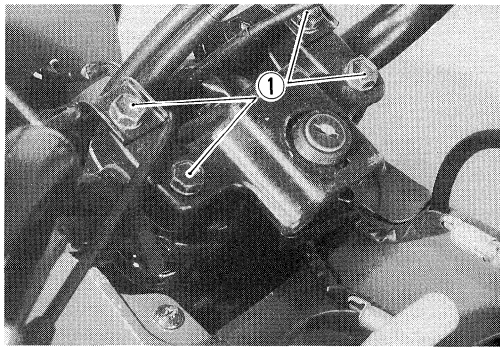

GENERAL LUBRICATIONS

Lubricate Every 3 months

Proper lubrication is important for smooth operation and long life of each working part of the vehicle. The major lubrication points are indicated below.

NOTE:

- * Lubricate exposed parts which are subject to rust, with motor oil or grease.
- * Before lubricating each part, clean off any rusty spots and wipe off any grease, oil dirt or grime.

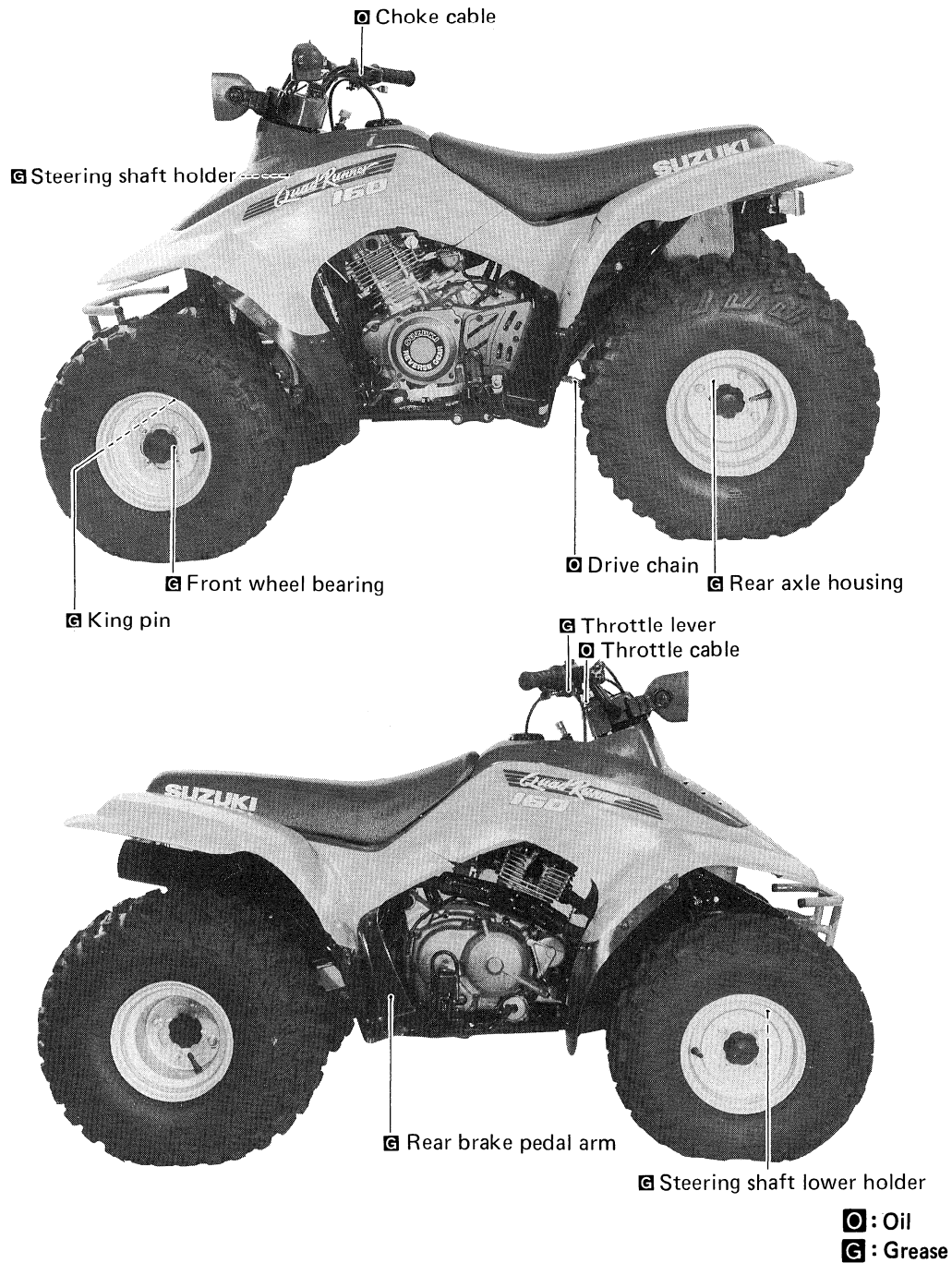

ENGINE

CONTENTS

COMPRESSION PRESSURE	3- 1
INITIAL ENGAGEMENT AND CLUTCH LOCK-UP INSPECTION	3- 1
ENGINE COMPONENTS REMOVABLE WITH THE ENGINE IN PLACE	3- 3
ENGINE REMOVAL AND REMOUNTING	3- 4
ENGINE DISASSEMBLY	3- 8
ENGINE COMPONENTS INSPECTION AND SERVICING	3-15
CYLINDER HEAD COVER	3-15
ROCKER ARM	3-15
CYLINDER HEAD	3-16
VALVES	3-17
CAMSHAFT	3-22
CAM CHAIN	3-24
CYLINDER	3-24
PISTON	3-24
PISTON RING	3-25
CONROD	3-27
CRANKSHAFT	3-27
CLUTCH	3-28
CLUTCH COVER AND CLUTCH ADJUSTER	3-29
STARTER CLUTCH	3-31
OIL PUMP	3-32
TRANSMISSION	3-32
CRANKCASE BEARINGS	3-35
ENGINE REASSEMBLY	3-36
OIL SEALS	3-36
CRANKSHAFT	3-36
GEARSHIFT CAM AND FORK	3-37
CRANKCASE	3-38
REVERSE CAM STOPPER AND SWITCH	3-39
OIL PUMP	3-40
CLUTCH	3-41
STARTER CLUTCH AND MAGNETO ROTOR	3-43
OIL RING AND PISTON RING	3-44
PISTON AND CYLINDER	3-45
CYLINDER HEAD	3-46
CAMSHAFT	3-47
CYLINDER HEAD COVER	3-48
CAM DRIVE CHAIN TENSIONER	3-49
VALVE CLEARANCE	3-49
MAGNETO COVER	3-49

COMPRESSION PRESSURE

COMPRESSION PRESSURE

NOTE:

- * Before testing the engine for compression pressure, make sure that the cylinder head nuts are tightened to specified torque values and valve are properly adjusted.
- * Have the engine warmed up by idling before testing it.

- Remove the spark plug.
- Fit the compression gauge set ① and ② to the plug hole, taking care to make the connection absolutely tight.
- Turn the throttle lever into wide-open position.
- Crank the engine a few seconds with the starter, and read the highest gauge indication as the compression of the cylinder.

09915-64510: Compression gauge

09918-02410: Adapter

Compression pressure

Standard	Limit
1 000 – 1 400 kPa (10 – 14 kg/cm ²) (142 – 199 psi)	800 kPa (8 kg/cm ²) (114 psi)

A low compression pressure may indicate any of the following malfunction:

- * Excessively worn cylinder wall
- * Worn piston or piston rings
- * Piston rings stuck in the grooves
- * Poor seating contact of valves
- * Defective cylinder head gasket

When the compression pressure noted is down to or below the limit indicated above, the engine must be disassembled, inspected and repaired as required, with these five malconditions in mind.

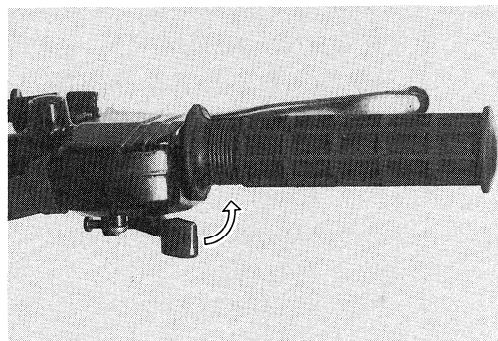
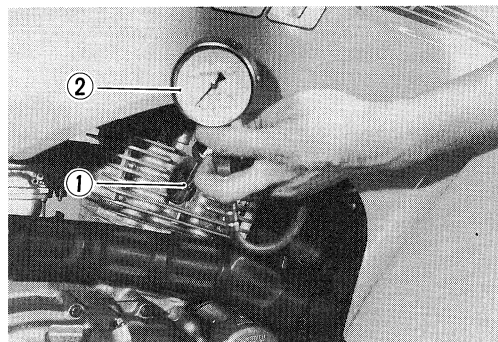

INITIAL ENGAGEMENT AND CLUTCH LOCK-UP INSPECTION

The LT160E is equipped with a centrifugal type automatic clutch.

To insure proper performance and longevity of the clutch assemblies it is essential that the clutches engage smoothly and gradually. Two inspection checks must be performed to thoroughly check the operation of the drivetrain. Follow the procedures listed.

NOTE:

- * Before checking the initial engagement and clutch lock-up, check the oil level.
- * Have the engine warmed up by idling before checking it.

INITIAL ENGAGEMENT INSPECTION

- Connect an electric tachometer to the engine.
- Start the engine.
- Shift the gearshift lever to the low position.
- Seated on the machine, increase the engine RPMs slowly and note the RPM at which the machine begins to move forward.

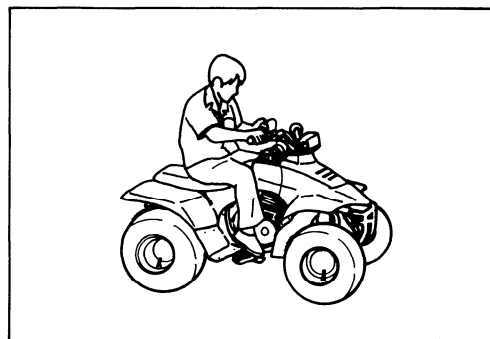

09900-26005: Engine tachometer (Not available in U.S.A.)

Engagement r/min.

Standard	2 200 r/min
Tolerance	± 200 r/min

If the engagement r/min does not coincide with the standard range, inspect the following items for any abnormality.

	Page
* Clutch shoes	3-28
* Clutch wheel	3-29
* Clutch drive and driven plates	3-28

CLUTCH LOCK-UP INSPECTION

Perform this inspection to determine if the clutch is engaging fully and not slipping.

- Connect an electric tachometer to the engine.
- Start the engine.
- Shift the gearshift lever to the low position.
- Apply the front and rear brakes as firm as possible.
- Briefly open the throttle fully and note the maximum engine RPMs sustained during the test cycle.

Lock-up r/min.

Standard	3 500 r/min
Tolerance	± 250 r/min

CAUTION:

Do not apply full power for more than 10 seconds or damage to the clutch or engine may occur.

If the lock-up r/min does not coincide with the standard range, inspect the following items for any abnormality.

	Page
* Clutch shoes	3-28
* Clutch wheel	3-29
* Clutch drive and driven plates	3-28

ENGINE COMPONENTS REMOVABLE WITH THE ENGINE IN PLACE

The parts listed below can be removed and reinstalled without removing the engine from the frame.
Refer to the page listed in this section for removal instruction.

ENGINE LEFT SIDE	ENGINE CENTER	ENGINE RIGHT SIDE
Refer to page	Refer to page	Refer to page
Engine sprocket	Cam drive chain tensioner	Oil filter
Reverse shift arm	Cylinder head cover	Clutch cover
Gearshift lever	Camshaft	Clutch release mechanism
Magneto cover/stator coil	Cylinder head	Primary drive gear
Magneto rotor	Cylinder	Clutch assembly
Starter idle gear	Piston	Oil pump assembly
Starter clutch	Starter motor	Gearshift shaft
	Cam drive chain	
	Oil sump filter	

ENGINE REMOVAL AND REMOUNTING

ENGINE REMOVAL

Before taking the engine out of the frame, thoroughly clean the engine with a suitable cleaner. The procedure of engine removal is sequentially explained in the following steps.

- Drain engine oil. (Refer to page 2-7.)
- Remove the seat, front fender and rear fender. (Refer to page 6-1.)

WARNING:

When removing the battery, be sure to remove the minus terminal first.

- Turn the fuel cock lever to "OFF" position and disconnect the fuel hose.
- Loosen the lock nut ① and remove the reverse cable.
- Remove the fuel tank mounting bolts ②, and remove the fuel tank.
- Disconnect the magneto/neutral indicator switch lead wires ③ and crankcase breather hose ④.
- Loosen the clamp screws ⑤ and remove the carburetor.

- Disconnect the starter motor lead wire, ground wire and spark plug cap.

- Remove the muffler by removing the exhaust pipe nuts and muffler mounting bolt.

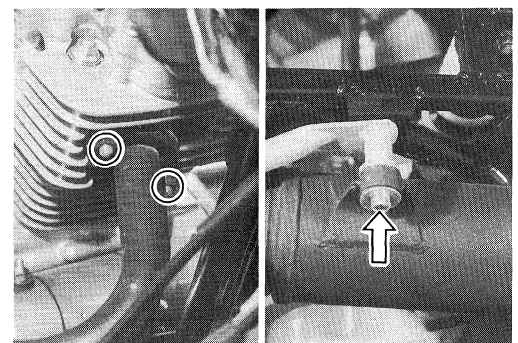
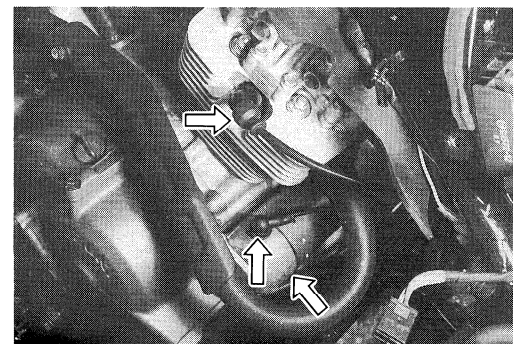
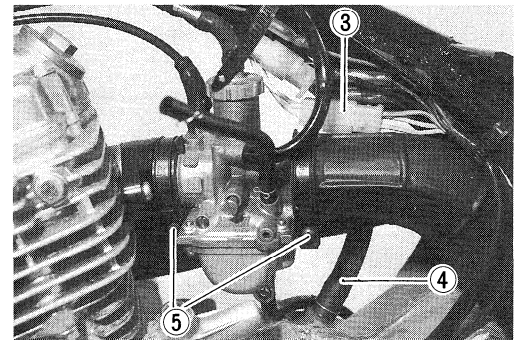
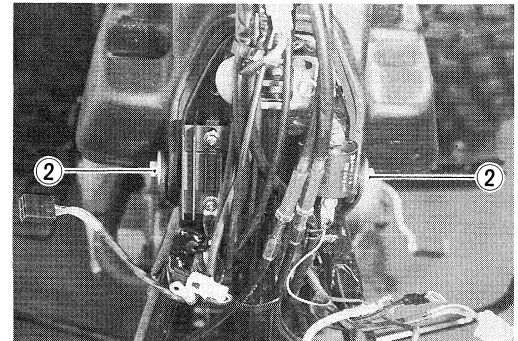
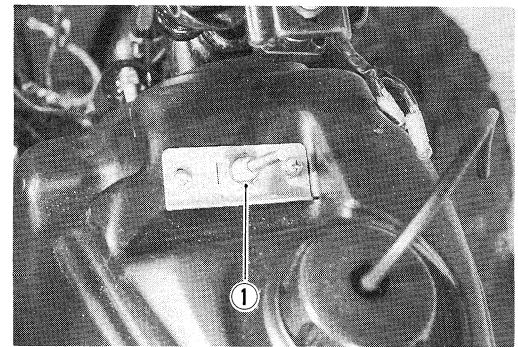

3-5 ENGINE

- Remove the engine sprocket cover.
- Loosen the drive chain adjuster. (Refer to page 2-10.)
- Flatten the lock washer and remove the engine sprocket nut.
- Remove the engine sprocket with drive chain.

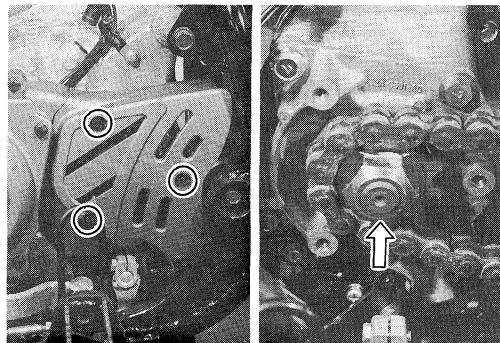

- Remove the left footrest and gearshift lever.
- Remove the reverse shift arm.

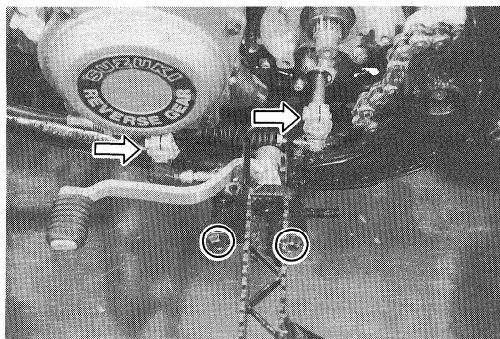

- Remove the reverse cable.

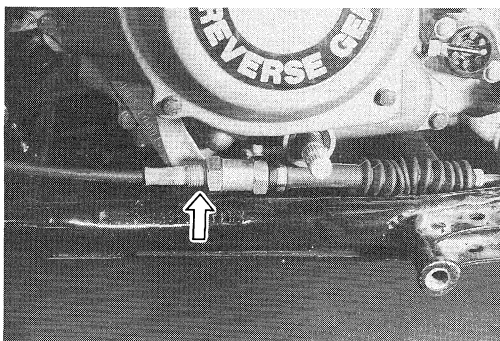

- Remove the engine mounting bolts and brackets.
- Remove the engine from the frame.

NOTE:

The engine must be removed from the left side.

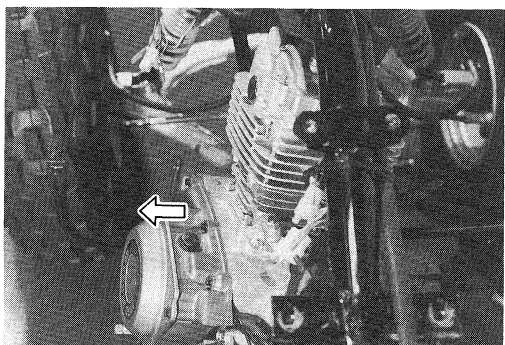
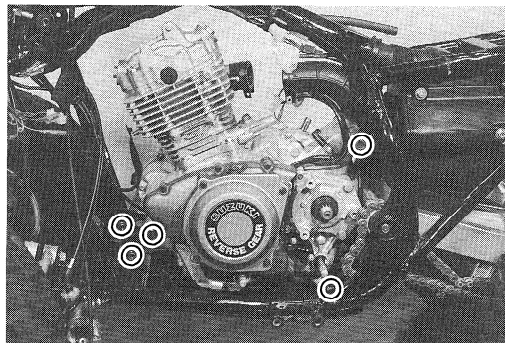

ENGINE REMOUNTING

The engine can be mounted in the reverse order of removal.

NOTE:

The engine mounting nuts are self-lock style. Once the nut has been removed, it is no longer of any use. Be sure to use new nuts and tighten them to the specified torque.

Tightening torque for engine mounting bolts and nuts

ITEM	N·m	kg·m	lb·ft
Ⓐ	60 – 72	6.0 – 7.2	43.5 – 52.0
Ⓑ	22 – 34	2.2 – 3.4	16.0 – 24.5

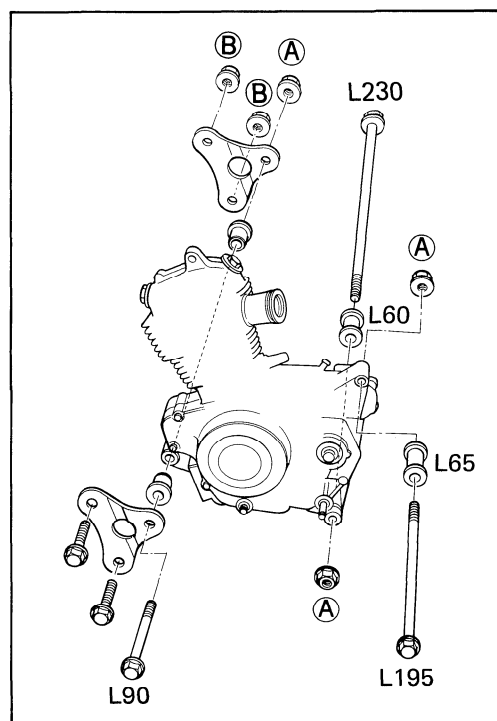

- Tighten the engine sprocket nut to the specified torque and bend the lock washer.

Tightening torque: 80 – 100 N·m
(8.0 – 10.0 kg·m, 58.0 – 72.5 lb·ft)

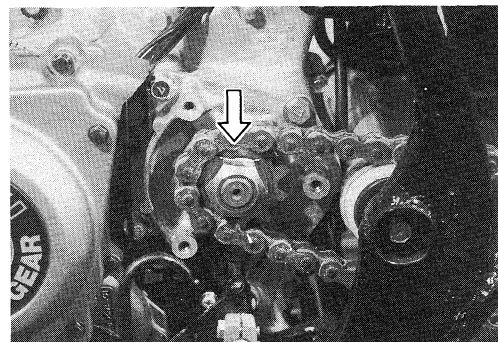

- When installing the reverse shift arm, align the punched mark ① on the reverse shift cam with slit ② of reverse shift arm at reverse position.

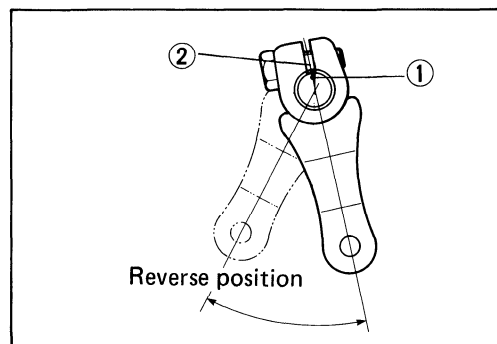

- Tighten the exhaust pipe nuts ③ and muffler mounting bolt ④ to the specified torque.

Tightening torque

③ : 9 – 12 N·m (0.9 – 1.2 kg·m, 6.5 – 8.5 lb·ft)

④ : 18 – 28 N·m (1.8 – 2.8 kg·m, 13.0 – 20.0 lb·ft)

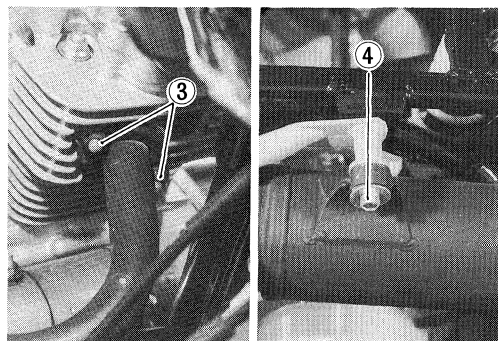

3-7 ENGINE

- Pour 1 900 ml (2.0/1.8 US/Imp qt) of engine oil SAE 10W/40 graded API SE or SF into the engine after overhauling engine.
- Start up the engine and allow it run for several seconds at idle speed. About one minute after stopping engine, check oil level. If the level is below the upper line, add oil until the level reaches the upper line.
- After remounting the engine, following adjustments are necessary.
 - * Idling speed Refer to page 2-6
 - * Throttle cable play Refer to page 2-6
 - * Drive chain slack Refer to page 2-11

ENGINE DISASSEMBLY

- Remove the chain tensioner.

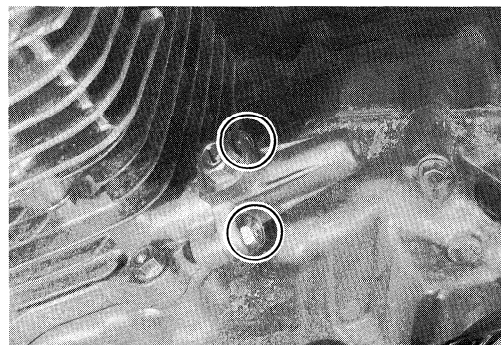

- Remove the magnto cover.

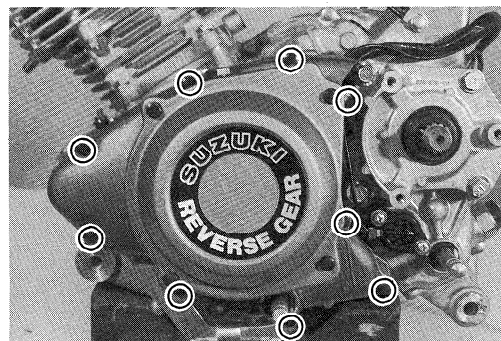

- Rotate the rotor until the "T" line ① on the rotor is aligned with the index mark ② on the crankcase.

NOTE:

When removing the cylinder head cover, piston must be at top dead center on compression stroke.

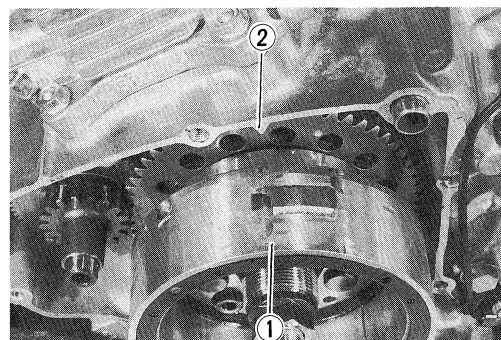

- Loosen the cylinder head cover bolts in the order indicated in Fig. and detach the cylinder head cover.

NOTE:

When removing the cylinder head cover, do not remove conically recessed top bolts ①.

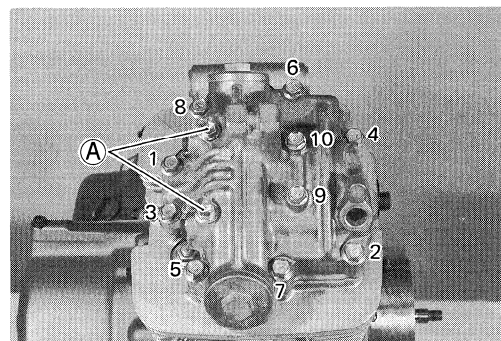

- Flatten the lock washer and remove the camshaft sprocket bolts.
- Remove the camshaft and sprocket.

NOTE:

The cam chain tensioner bolt ③ is to be removed only when disassembling the engine.

NOTE:

Do not drop the camshaft drive chain, pin and sprocket into the crankcase.

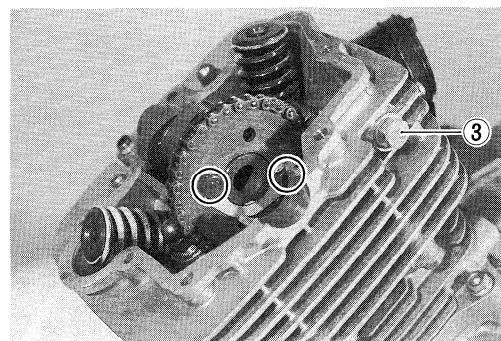

3-9 ENGINE

- Loosen the four cylinder head nuts diagonally and two nuts ①, then detach the cylinder head.

NOTE:

If it is difficult to remove the cylinder head, gently pry it off while tapping the finless portion of the cylinder head with a plastic hammer. Be careful not to break the fins.

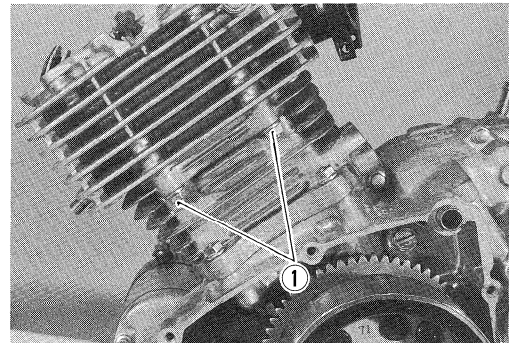
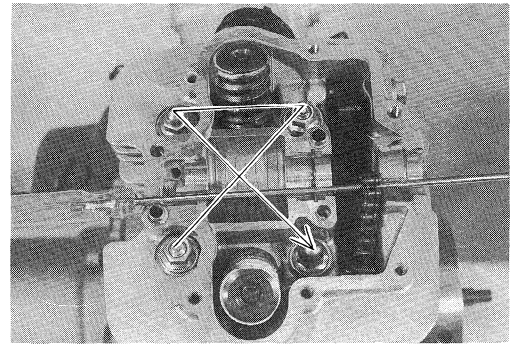

- Remove the cam chain guide ②.
- Remove the cylinder by removing the cylinder base nuts.

CAUTION:

If tapping with plastic hammer is necessary, do not break the fins.

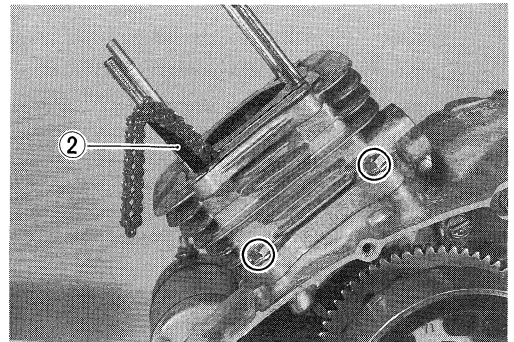

- Place a clean rag over the cylinder base to prevent piston pin circlip from dropping into crankcase, and then remove the piston pin circlip with longnose pliers.

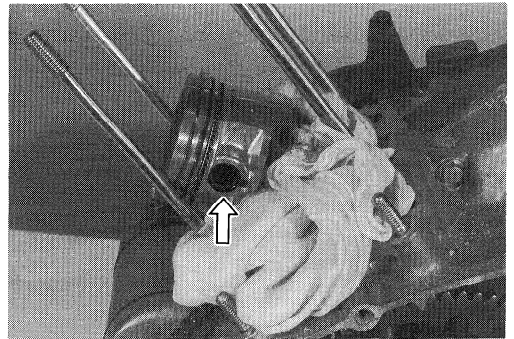

- Remove the piston pin with the special tool.

09910-34510: Piston pin puller

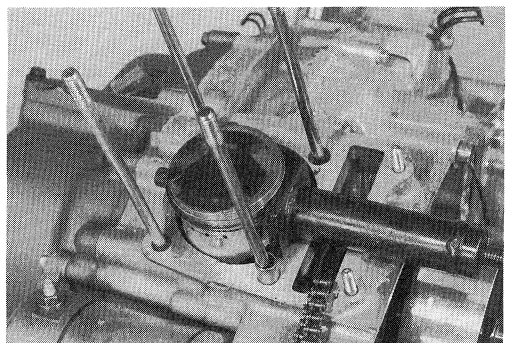

- Remove the starter motor.

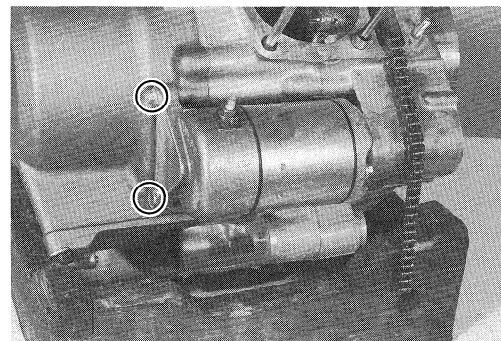

- Remove the starter motor idle gear shaft ① and idle gear ②.

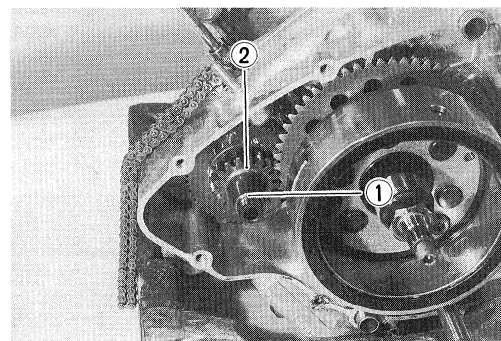

- Remove the magneto nut with the special tool.

09930-44913: Rotor holder

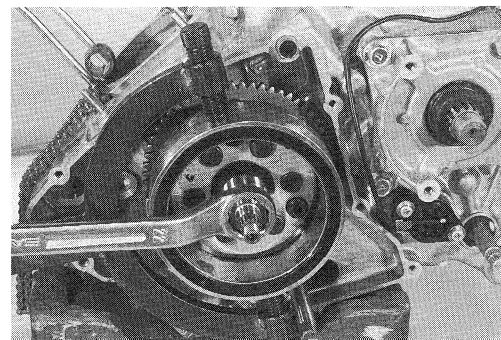

- Remove the magneto rotor/starter clutch with the special tool.

09930-34932: Rotor remover

NOTE:

Do not hit the rotor with a hammer.

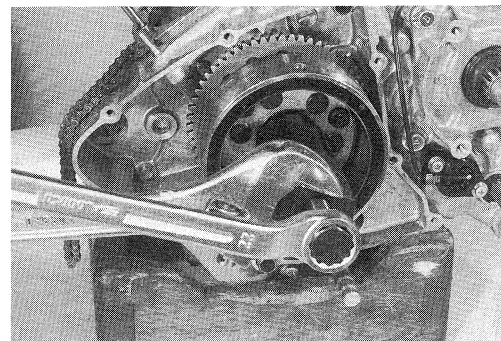

- Remove the starter clutch gear, bearing and key ③.

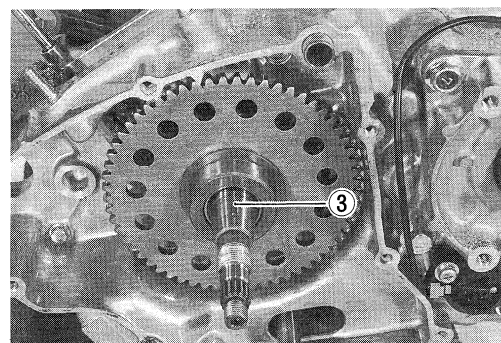

3-11 ENGINE

- Remove the cam chain.

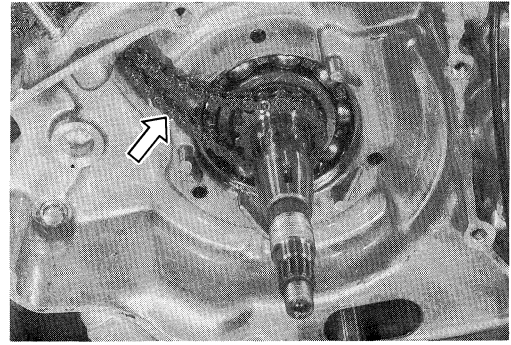

- Remove the drive shaft oil seal retainer.
- Remove the neutral indicator switch.

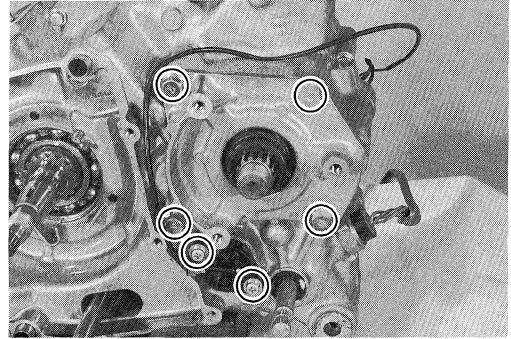

- Remove the reverse switch ①.
- Remove the gearshift cam stopper plug ② and spring ③ by removing the cam stopper bolt ④.

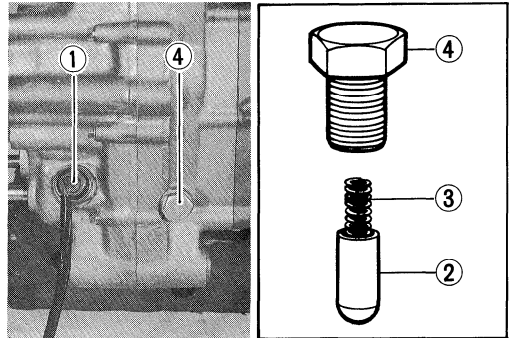

- Remove the oil filter cap and oil filter.

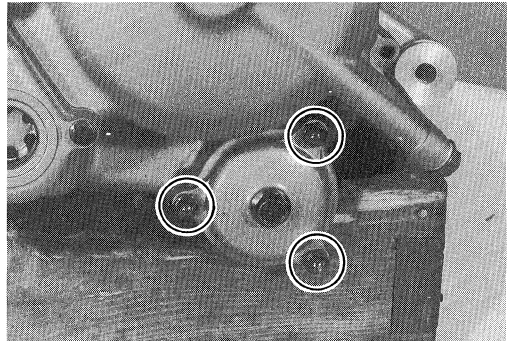

- Remove the clutch cover.

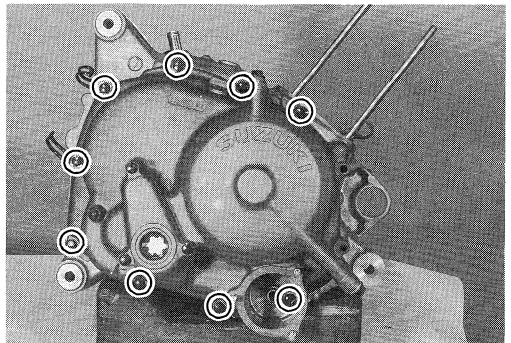

- Remove the clutch shoe assembly by removing the clutch shoe nut with the special tool.

09910-20115: Conrod holder

CAUTION:

Clutch shoe nut has left-hand thread.

Do not attempt to disassemble the clutch shoe, it is not serviceable.

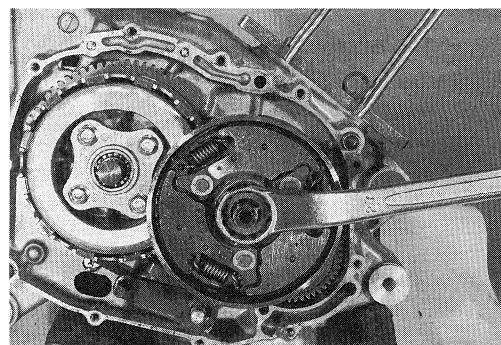

- Remove the primary drive gear with one-way clutch.

- ① Primary drive gear
- ② One-way clutch
- ③ One-way clutch inner race

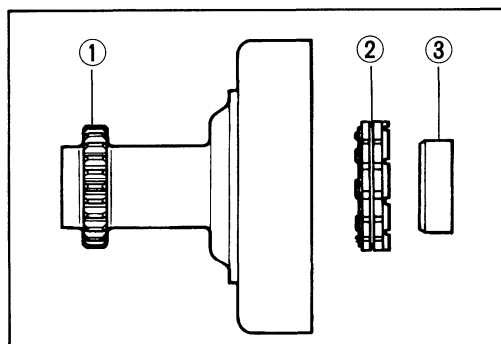
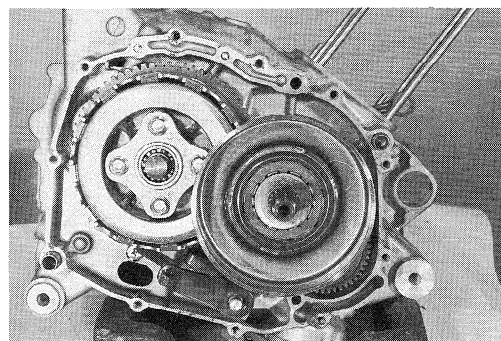

- Remove the release plate by removing the four bolts.

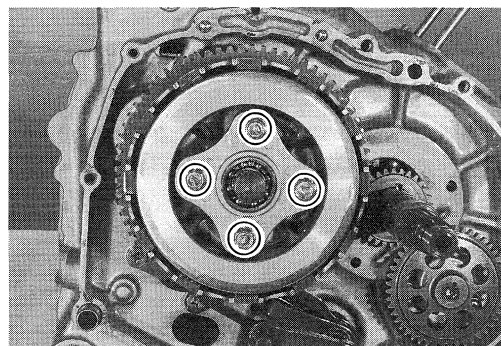

- Remove the springs.
- Remove the clutch sleeve hub nut with the special tool.

09920-53730: Clutch sleeve hub holder

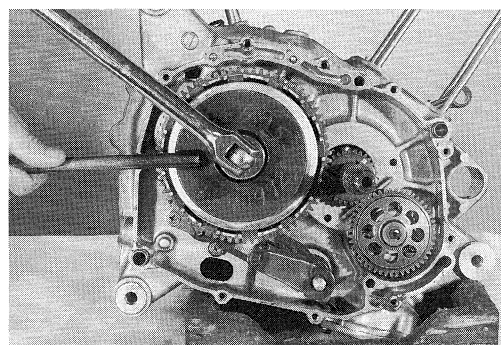

3-13 ENGINE

- Remove the clutch pressure disc, drive plates and driven plates.
- Remove the clutch sleeve hub.

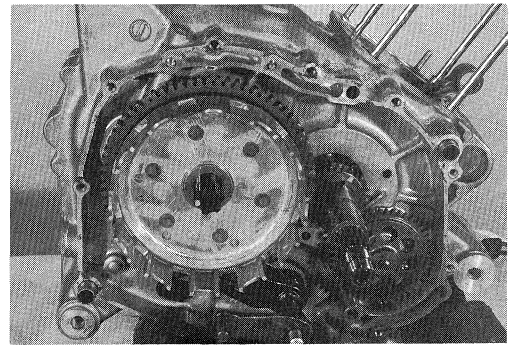

- Remove the oil pump drive gear and driven gear.
- Remove the oil pump.

NOTE:

Do not lose the pin.

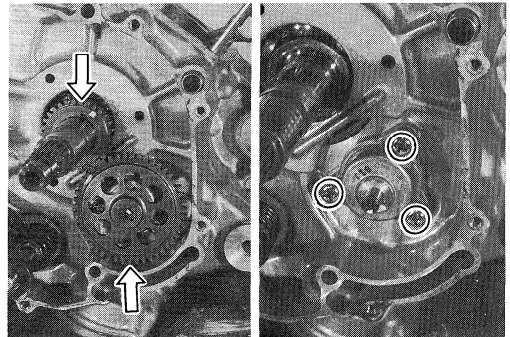

- Remove the gearshift shaft.

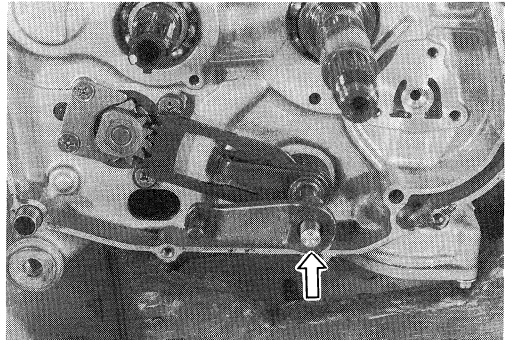

- Remove the cam driven gear ① by removing the screws ②.

NOTE:

When removing the cam driven gear, do not lose gearshift pawl ③, pin ④ and spring ⑤.

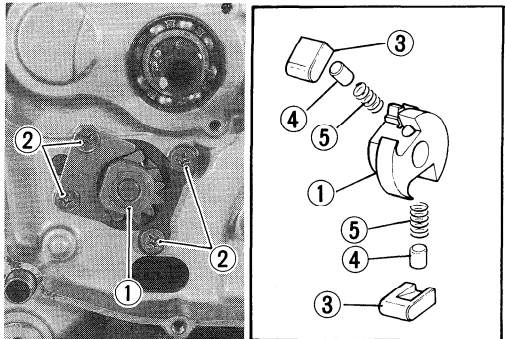

- Remove the oil jets.

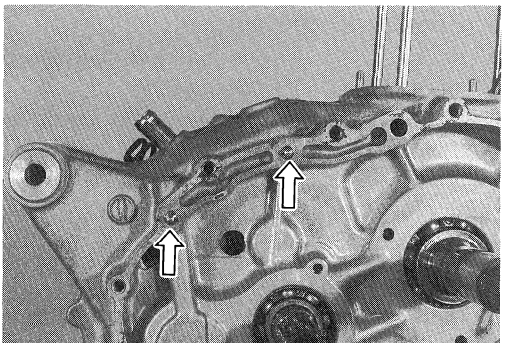

- Remove the crankcase securing bolts.

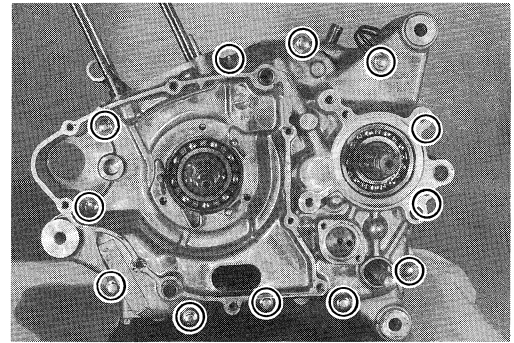

- Separate the crankcase with the special tool.

09920-13120: Crankcase separating tool

CAUTION:

The crankshaft and transmission components must remain in the left crankcase half. This is necessary because the gearshift cam stopper is mounted on the left crankcase half and will be damaged if the transmission components remain in the right half.

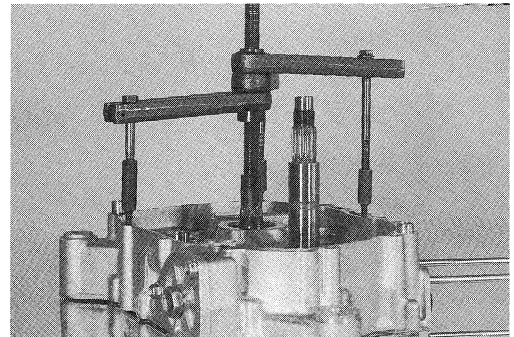

- Draw out the gearshift fork shafts ① and reverse gearshift shaft ②, and then remove the clusters of gears, forks and gearshift cam.

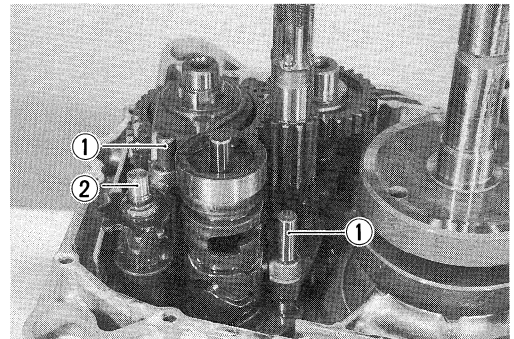

- Remove the crankshaft with the special tool.

**09920-13120: Crankshaft remover
(Crankcase separating tool)**

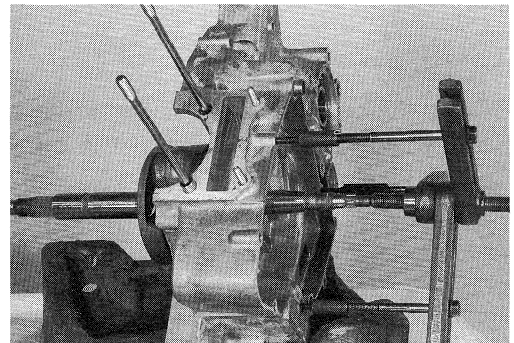

- Remove the oil sump filter cap and oil sump filter.

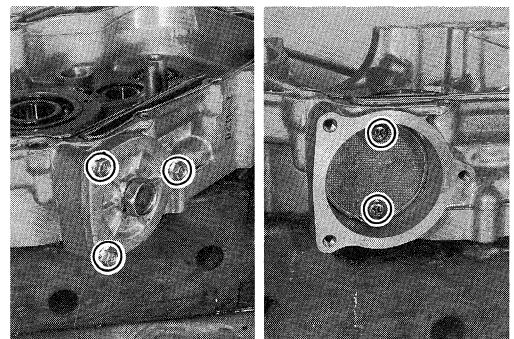

ENGINE COMPONENTS INSPECTION AND SERVICING

CYLINDER HEAD COVER SERVICING

CAUTION:

Be sure to identify each removed part as to its location, and lay the parts out in groups designated as "Exhaust", "Inlet", so that each will be restored to the original location during assembly.

- Remove the rocker arm shaft set bolts ①, and remove the rocker arm shafts with a pliers.

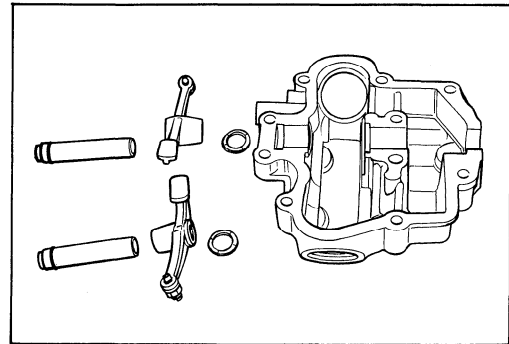
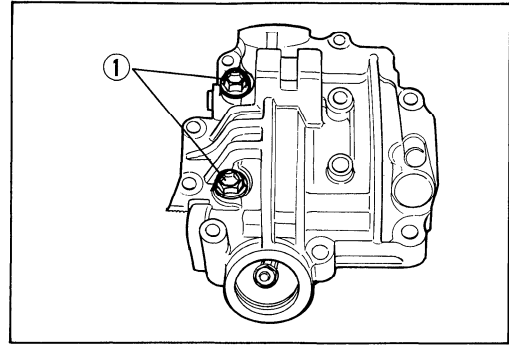

CYLINDER HEAD COVER DISTORTION

After removing sealant (SUZUKI BOND No. 1207B/1215) from the fitting surface of the cylinder head cover, place the cylinder head cover on a surface plate and check for distortion with a thickness gauge. Check points are shown in the illustration.

Service Limit: 0.05 mm (0.002 in)

If the distortion exceeds the limit, replace the cylinder head cover.

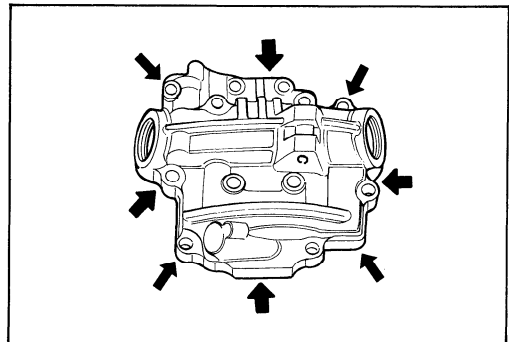

ROCKER ARM I.D.

When checking the valve rocker arm, the inside diameter of the valve rocker arm and wear of the camshaft contacting surface should be checked.

Standard: 12.000 – 12.018 mm (0.4724 – 0.4731 in)

09900-20605: Dial calipers (Not available in U.S.A.)

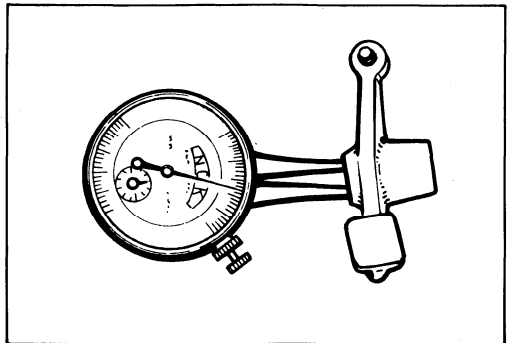

ROCKER ARM SHAFT O.D.

Measure the diameter of rocker arm shaft with a micrometer.

Standard: 11.977 – 11.995 mm (0.4715 – 0.4722 in)

09900-20205: Micrometer (0 – 25 mm)

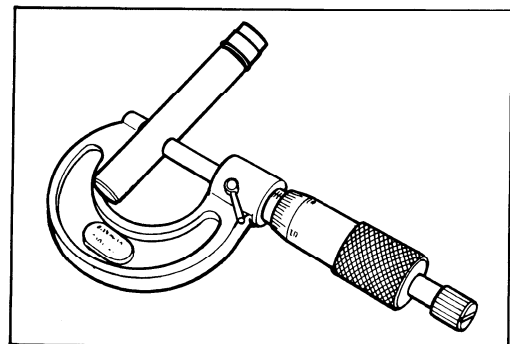

REASSEMBLY

- Apply SUZUKI MOLY PASTE to the rocker arm shafts.

99000-25140: SUZUKI Moly paste

CAUTION:

Use a new O-ring ① on the rocker arm shafts to prevent oil leakage.

- After inserting the shafts, tighten the set bolts ②.

Tightening torque: 8 – 10 N·m

(0.8 – 1.0 kg·m, 6.0 – 7.0 lb·ft)

NOTE:

Use a conically recessed top bolt as the set bolts.

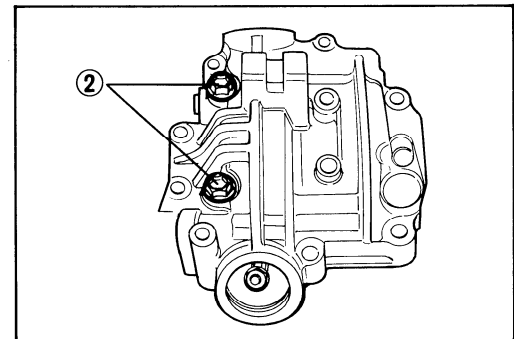
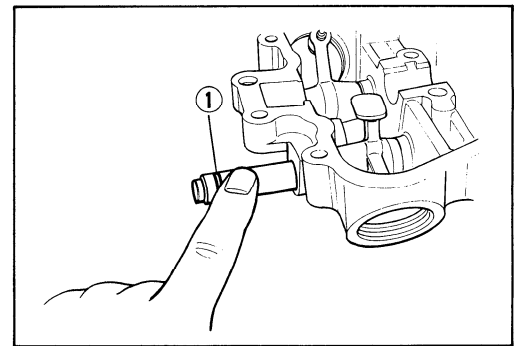

CYLINDER HEAD SERVICING

- Compress the valve spring with the special tools.

09916-14510: Valve spring compressor

09916-14910: Valve spring compressor attachment

- Remove the valve cotters with the special tool.

09916-84510: Tweezers

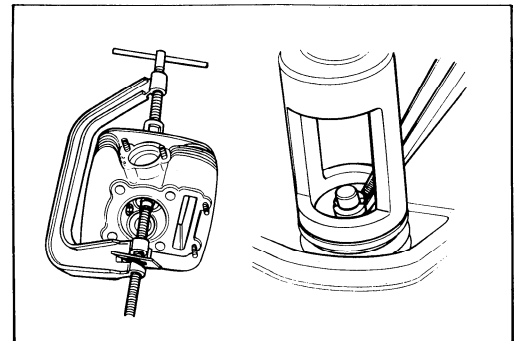

- Remove the valve spring retainer and spring.
- Remove the valve from the other side.

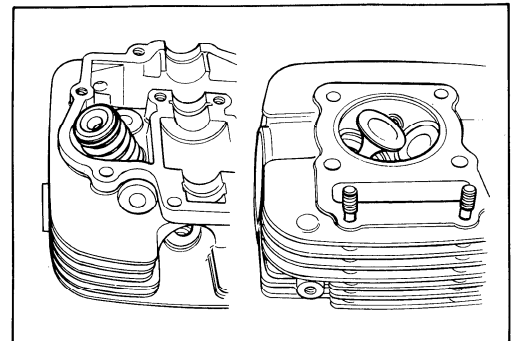

- Remove the oil seal with a long-nose pliers.
- Remove the spring seat.

NOTE:

Removal of valves completes ordinary disassembling work. If valve guides have to be removed for replacement after inspecting related parts, carry out the steps shown in valve guide servicing.

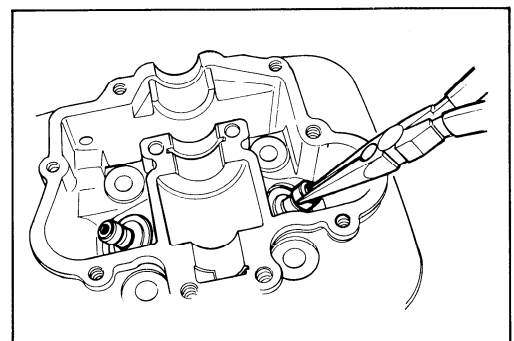

CYLINDER HEAD DISTORTION

Decarbon combustion chamber.

Check the gasketed surface of the cylinder head for distortion with a straightedge and thickness gauge, taking a clearance reading at several places as indicated. If the largest reading at any position of the straightedge exceeds the limit, replace the cylinder head.

Service Limit: 0.05 mm (0.002 in)

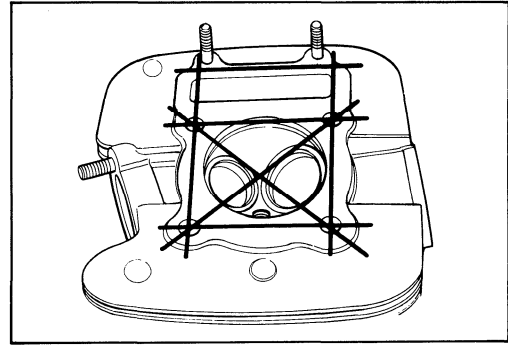

VALVE FACE WEAR

Measure the thickness T and, if the thickness is found to have been reduced to the limit, replace the valve.

NOTE:

Visually inspect each valve for wear of its seating face. Replace any valve with an abnormally worn face.

Service Limit: 0.5 mm (0.02 in)

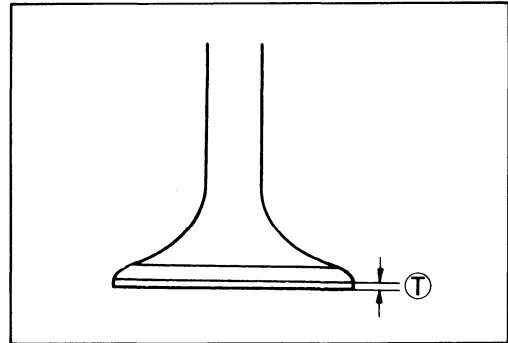

VALVE STEM RUNOUT

Support the valve with "V" blocks, as shown, and check its runout with a dial gauge. The valve must be replaced if the runout exceeds the limit.

Service Limit: 0.05 mm (0.002 in)

09900-20606: Dial gauge (1/100 mm)

09900-20701: Magnetic stand (Not available in U.S.A.)

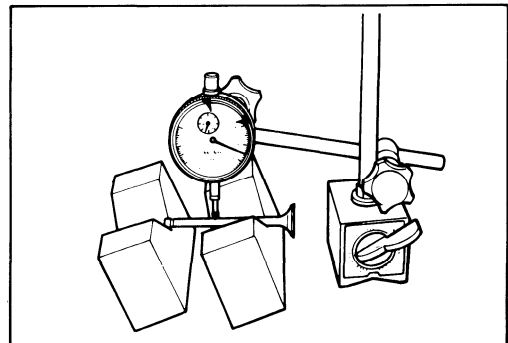

VALVE GUIDE-VALVE STEM CLEARANCE

Measure the clearance in two direction, "X" and "Y", perpendicular to each other, by rigging up the dial gauge as shown. If the clearance measured exceeds the limit specified below, then determine whether the valve or the guide should be replaced to reduce the clearance to within the standard range:

	Standard	Service Limit
IN.	0.010 – 0.037 mm (0.0004 – 0.0015 in)	0.35 mm (0.014 in)
EX.	0.030 – 0.057 mm (0.0012 – 0.0022 in)	0.35 mm (0.014 in)

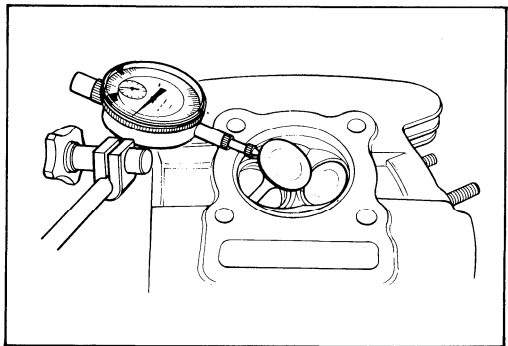

VALVE HEAD RADIAL RUNOUT

Place the dial gauge at right angles to the valve head, and measure the valve head radial runout.

If it measures more than limit, replace the valve.

Service Limit: 0.03 mm (0.001 in)

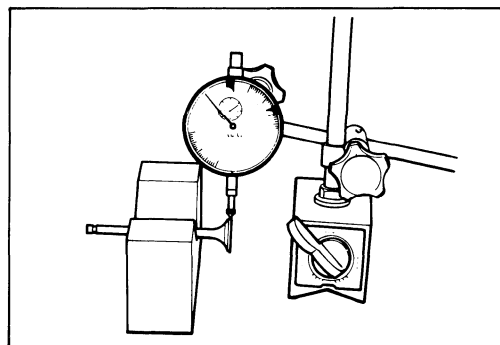

VALVE STEM WEAR

If the valve stem is worn down to the limit, when measured with a micrometer, and if the clearance is found to be in excess of the limit indicated above, replace the valve. If the stem is within the limit, then replace the guide. After replacing valve or guide, be sure to recheck the clearance.

Valve stem O.D. Standard

IN. : 5.475 – 5.490 mm (0.2155 – 0.2161 in)

EX.: 5.455 – 5.470 mm (0.2148 – 0.2153 in)

09900-20205: Micrometer (0 – 25 mm)

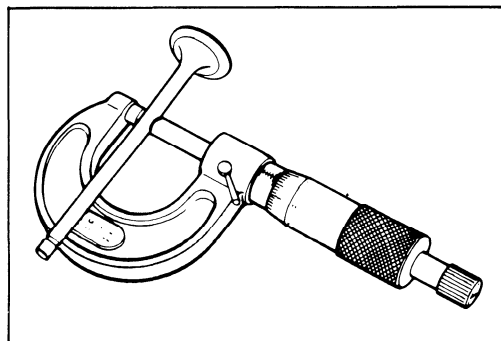

VALVE GUIDE SERVICING

- Remove the valve guide with a valve guide remover.

09916-44910: Valve guide remover

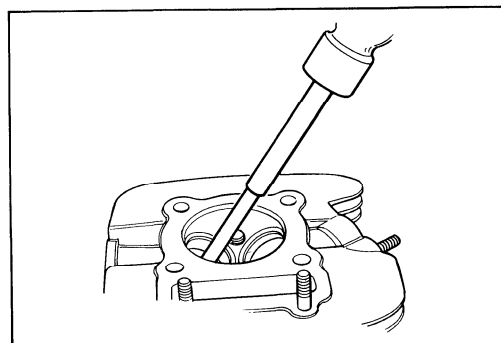

- Re-finish the valve guide holes in cylinder head with a 11.3 mm reamer and handle.

09916-34561: 11.3 mm reamer

09916-34542: Reamer handle

- Fit a ring to each valve guide. Be sure to use new rings and valve guides. Rings and valve guides removed in disassembly must be discarded.

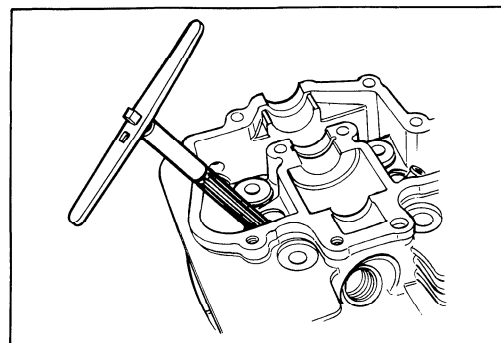

- Lubricate each valve guide and drive the guide into the guide hole with a valve guide installer.

09916-44910: Valve guide installer and remover

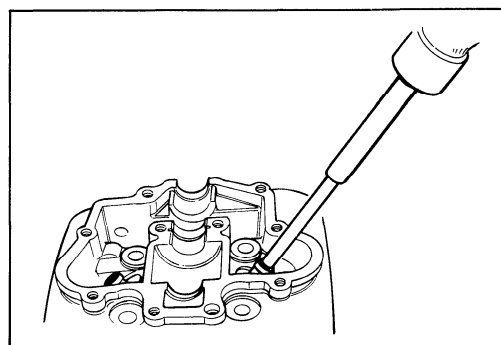

3-19 ENGINE

- After fitting valve guides, re-finish their guiding bores with a 5.5 mm reamer and handle.

09916-34550: 5.5 reamer

09916-34542: Reamer handle

CAUTION:

Be sure to clean and oil the guides after reaming.

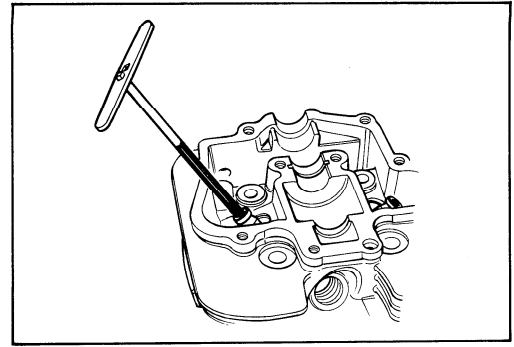

- Install the valve spring lower seat ①. Be careful not to confuse the lower seat with the spring retainer ②.

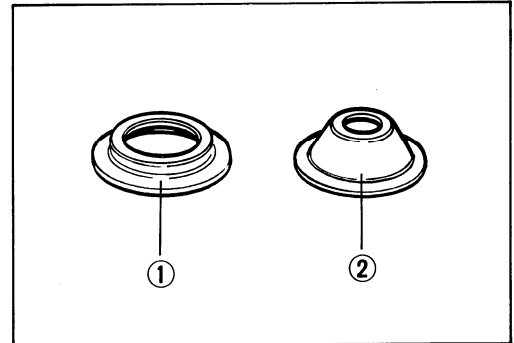

- Lubricate each seal, and push them into position with the finger tip.

CAUTION:

Do not reuse the oil seals.

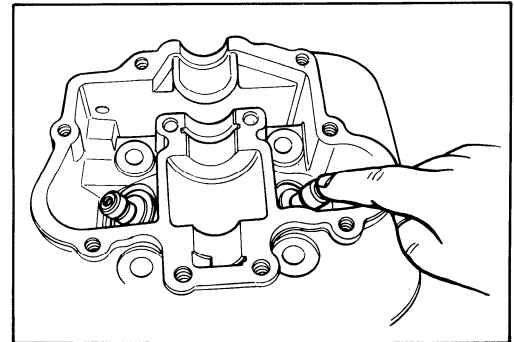

VALVE AND SEAT CONDITION

VALVE SEAT WIDTH

Coat the valve seat with prussian blue uniformly.

Fit the valve and tap the coated seat with the valve face in a rotating manner, in order to obtain a clear impression of the seating contact. In this operation, use the valve lapper to hold the valve head.

The ring-like dye impression left on the valve face must be continuous-without any break. In addition, the width of the dye ring, which is the visualized seat "width", must be within the specification.

Valve seat width

Standard W : 0.9 – 1.1 mm (0.035 – 0.043 in)

If either requirement is not met, correct the seat by servicing it as follows.

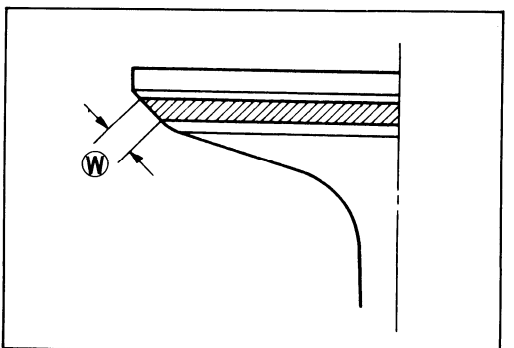
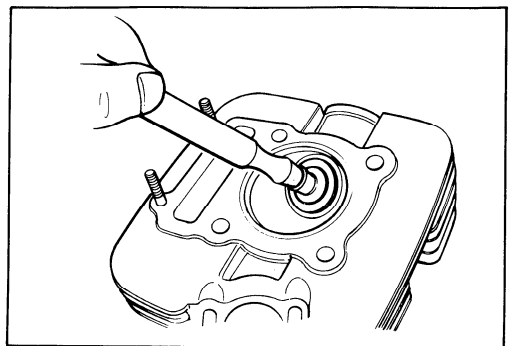

VALVE SEAT SERVICING

The valve seats for both intake and exhaust valves are angled to present two bevels, 15° and 45°.

	Intake side	Exhaust side
45°	N-116	N-116
15°	N-116	N-116

For U.S.A. model

N-100-10	Solid pilot
----------	-------------

For other models

09916-21110: Valve seat cutter set

09916-24420: Cutter (N-116)

09916-24450: Solid pilot (N-100-10)

NOTE:

The valve seat contact area must be inspected after each cut.

1. Insert with a slight rotation, the solid pilot that gives a snug fit. The shoulder on the pilot should be about 10 mm (0.39 in) from the valve guide.
2. Using the 45° cutter, descale and cleanup the seat with one or two turns.
3. Inspect the seat by the previous seat width measurement procedure. If the seat is pitted or burned, additional seat conditioning with the 45° cutter is required.

CAUTION:

Cut the minimum amount necessary from the seat to prevent the possibility of the valve stem becoming too close to the rocker arm for correct valve contact angle.

If the contact area is too low or too narrow, use the 45° cutter to raise and widen the contact area. If the contact area is too high or too wide, use the 15° cutter to lower and narrow the contact area.

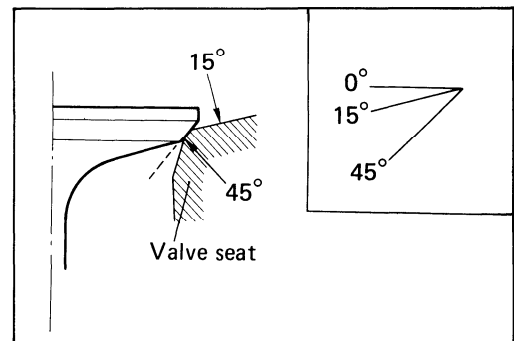
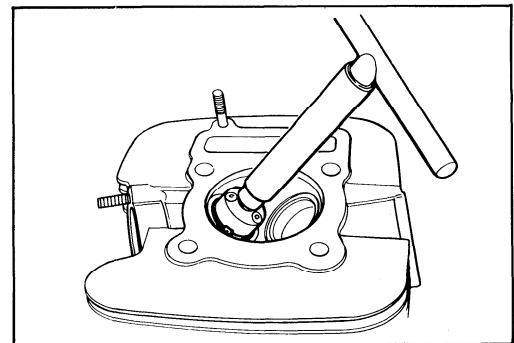

4. After the desired seat position and width is achieved, use the 45° cutter very lightly to clean up any burrs caused by the previous cutting operations. DO NOT use lapping compound after the final cut is made. The finished valve seat should have a velvety smooth finish and not a highly polished or shiny finish. This will provide a soft surface for the final seating of the valve which will occur during the first few seconds of engine operation.

5. Clean and assemble the head and valve components. Fill the intake and exhaust ports with gasoline to check for leaks. If any leaks occur, inspect the valve seat and face for burrs or other things that could prevent the valve from sealing.

WARNING:

Always use extreme caution when handling gasoline.

NOTE:

Be sure to adjust the valve clearance after reassembling the engine.

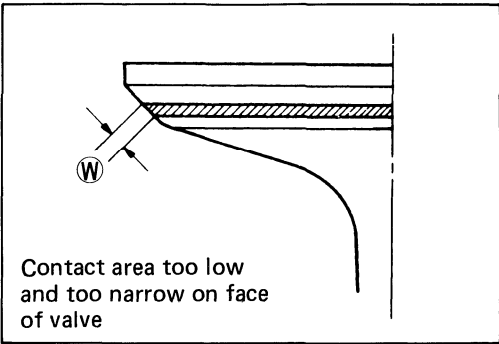
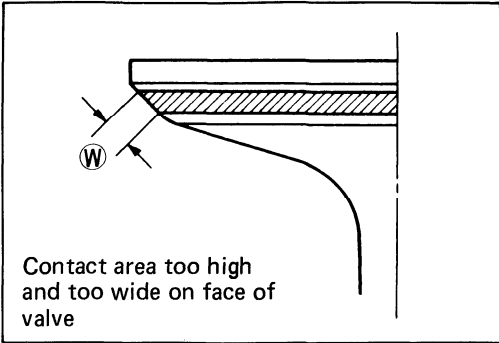

VALVE STEM END CONDITION

Inspect the valve stem end face for pitting and wear. If pitting or wear of the stem end face are present, the valve stem end may be resurfaced, providing that the length ① will not be reduced to less than 2.5 mm (0.10 in). If this length becomes less than 2.5 mm (0.10 in), the valve must be replaced. After installing a valve whose stem end has been ground off as above, check to ensure that the face ② of the valve stem end is above the cotters ③.

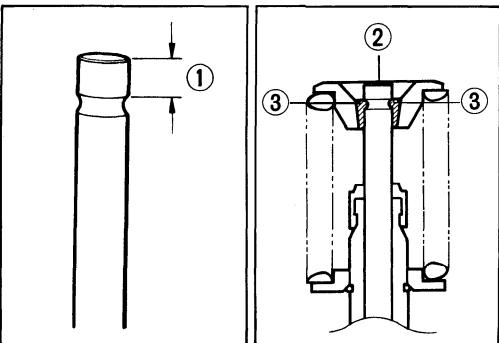

VALVE SPRINGS

Check the springs for strength by measuring their free lengths and also the force required to compress them. If the limit indicated below is exceeded by the free length reading or if the measured force does not fall within the range specified, replace with a SUZUKI spring as a set.

Valve spring free length

Service Limit: 39.5 mm (1.56 in) (IN. & EX.)

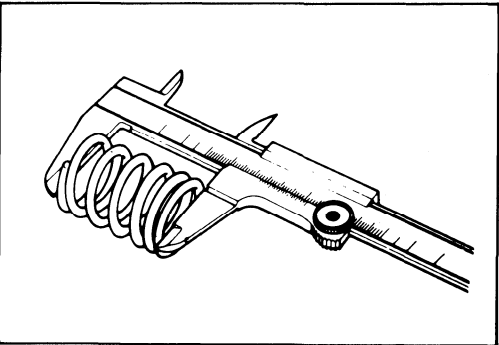

Valve spring tension

Standard: 18.4 – 21.6 kg/36.8 mm
(40.6 – 47.6 lbs/1.45 in)

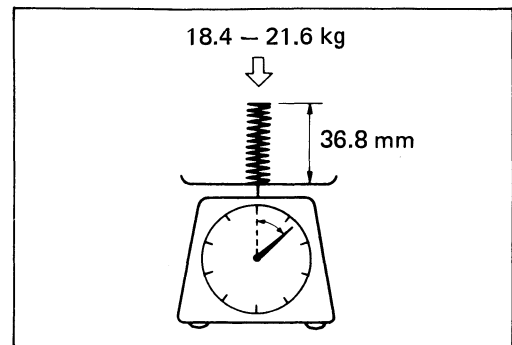
**REASSEMBLY**

- Insert the valves, with their stems coated with (SUZUKI MOLY PASTE) all around and along the full stem length without any break. Similarly oil the lip of the stem seal.

99000-25140: SUZUKI Moly paste

CAUTION:

When inserting each valve, take care not to damage the lip of the stem seal.

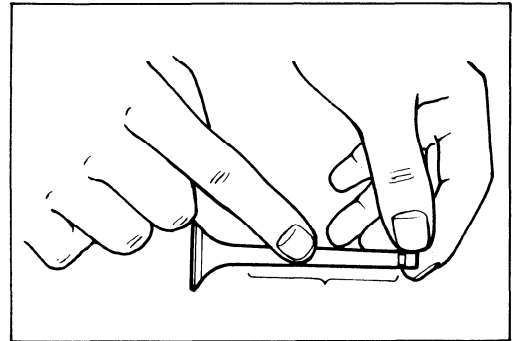

- Install the valve spring, making sure that the close-pitch end ① of spring goes in first to rest on the head. The coil pitch of spring vary: the pitch decreases from top to bottom, as shown in the illustration.

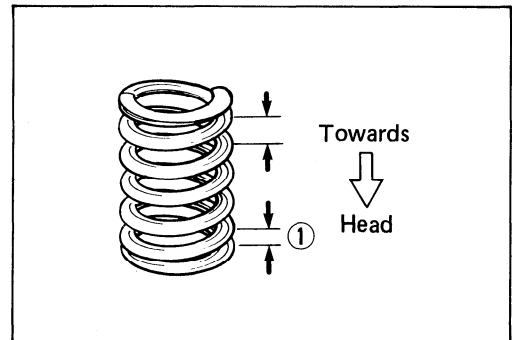

- Fit a valve spring retainer, compress the spring with a valve spring compressor and insert the cotters.

09916-14510: Valve spring compressor

09916-14910: Attachment

09916-84510: Tweezers

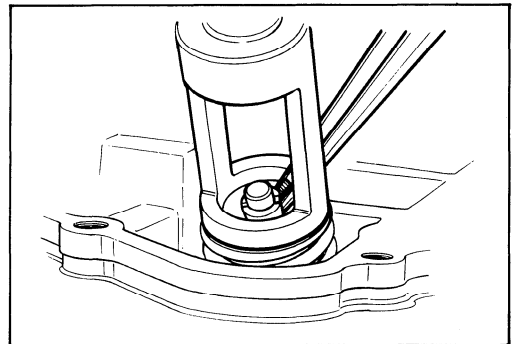
**CAMSHAFT**

The camshaft should be checked for runout and also for wear of cams and journals if the engine has been noted to produce abnormal noise or vibration or to lack output power. Any of these malconditions could be caused by a worn camshaft.

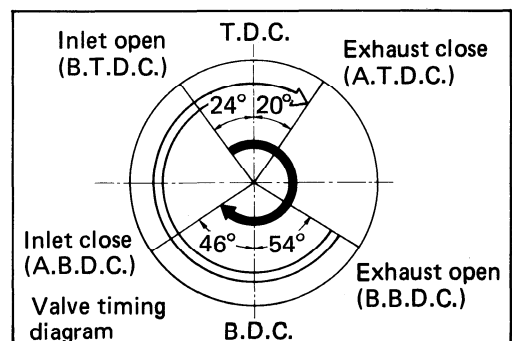

CAMSHAFT CAM WEAR

Worn-down cams are often the cause of mistimed valve operation resulting in reduced power output. The limit of cam wear is specified for both intake and exhaust cams in terms of cam height H , which is to be measured with a micrometer. Replace camshaft if it is found worn down to the limit.

09900-20202: Micrometer (25 – 50 mm)

Cam height

Service Limit IN. : 33.470 mm (1.3177 in)

EX.: 33.090 mm (1.3028 in)

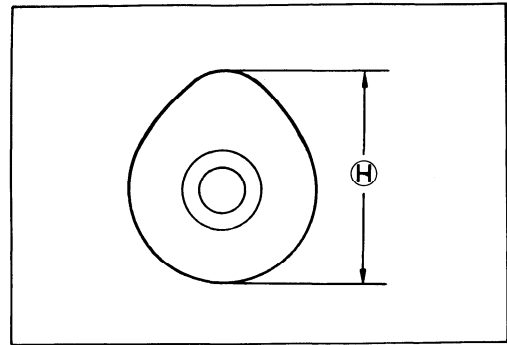

CAMSHAFT JOURNAL WEAR

Determine whether each journal is worn down to the limit or not by measuring camshaft journal oil clearance with the camshaft installed. Use plastigauge to read the clearance, which is specified as follows:

Camshaft journal oil clearance

Service Limit: 0.150 mm (0.0059 in)

- Tighten the cylinder head cover bolts evenly and diagonally to the specified torque.

Tightening torque: 9 – 11 N·m (0.9 – 1.1 kg-m, 6.5 – 8.0 lb-ft)

09900-22301: Plastigauge (Not available in U.S.A.)

NOTE:

To properly measure the oil clearance with plastigauge, all gasket material must be removed from fitting surfaces of cylinder head and cover. Do not apply SUZUKI BOND No. 1207B/1215 until after the oil clearance has been determined.

If the camshaft journal oil clearance measured exceeds the limit, measure the outside diameter of camshaft.

Replace either the cylinder head set or the camshaft if the clearance is incorrect.

Camshaft journal O.D.

Standard: 21.959 – 21.980 mm (0.8645 – 0.8654 in)

09900-20205: Micrometer (0 – 25 mm)

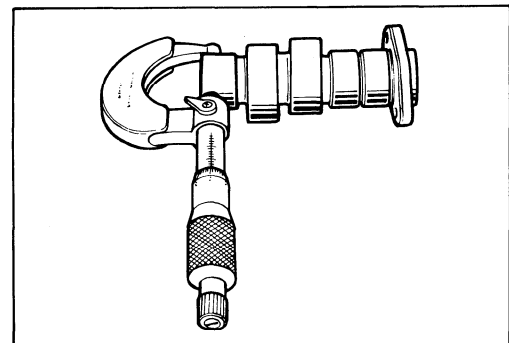
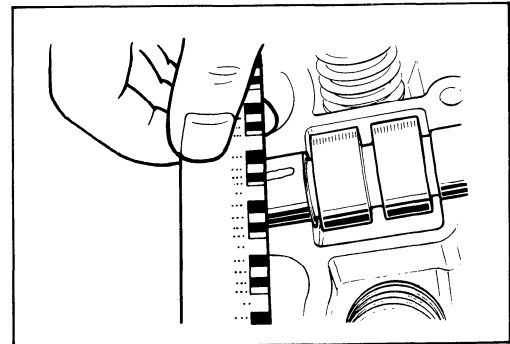

CAMSHAFT RUNOUT

Measure the runout with a dial gauge. Replace the camshaft if the runout exceeds the limit.

Service Limit: 0.10 mm (0.004 in)

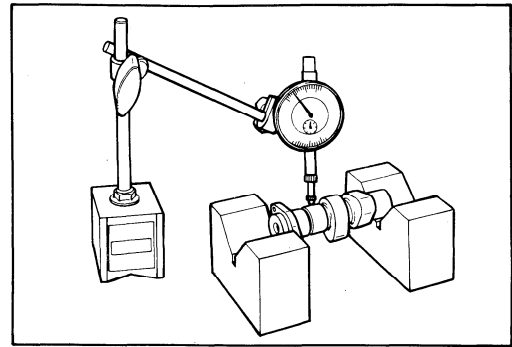

CAM CHAIN 20-PITCH LENGTH

Pull the chain tight to remove any slack, then using vernier calipers, measure the 20-pitch (21 pins) length of cam chain.

Service Limit: 129.0 mm (5.08 in)

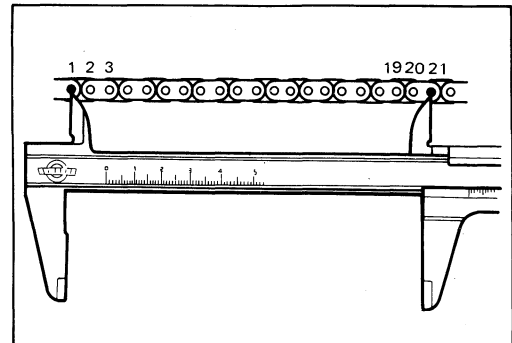

CYLINDER DISTORSION

Check the gasketed surface of the cylinder for distortion with a straightedge and thickness gauge, taking a clearance reading at several places as indicated. If the largest reading at any position of the straightedge exceeds the limit, replace the cylinder.

Service Limit: 0.05 mm (0.002 in)

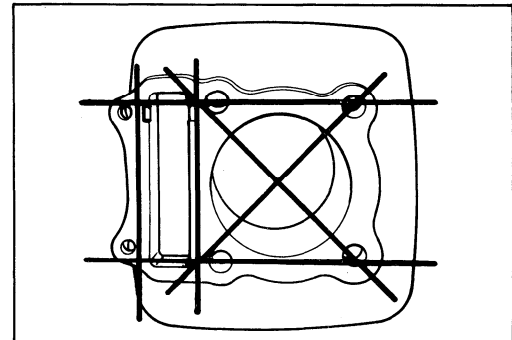

CYLINDER BORE

Measure the cylinder bore diameter at six places. If any one of the measurements exceeds the limit, overhaul the cylinder and replace the piston with an oversize, or replace the cylinder.

Service Limit: 58.100 mm (2.2874 in)

09900-20508: Cylinder gauge set

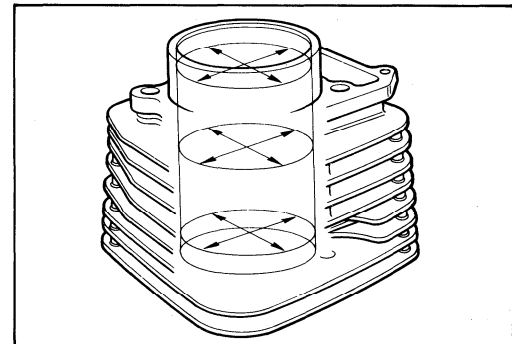

PISTON DIAMETER

Using a micrometer, measure the piston outside diameter 20 mm (0.79 in) from the skirt end as shown in Fig. If the measurement is less than the limit, replace the piston.

Service Limit: 57.880 mm (2.2787 in)

09900-20203: Micrometer (50 – 70 mm)

Piston oversize: 0.5, 1.0 mm

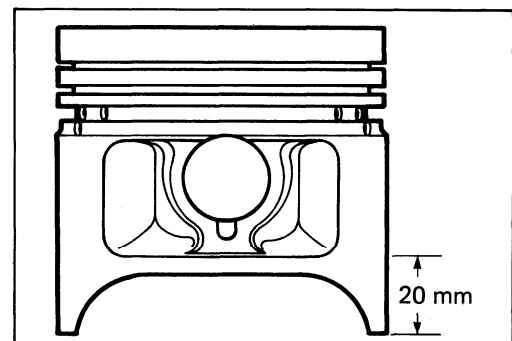

PISTON-CYLINDER CLEARANCE

As a result of the previous measurement, if the piston to cylinder clearance exceeds the limit shown below, overhaul the cylinder and use an oversize piston, or replace both cylinder and piston.

Service Limit: 0.120 mm (0.0047 in)

PISTON RING-GROOVE CLEARANCE

Measure the side clearance of the 1st and 2nd rings with a thickness gauge. If any of the clearances exceeds the limit, replace both piston and piston rings.

09900-20803: Thickness gauge

NOTE:

Using a soft metal scraper, decarbon the crown of the piston. Clean the ring grooves similarly.

Piston ring-groove clearance

Service Limit 1st : 0.180 mm (0.0071 in)

2nd: 0.150 mm (0.0059 in)

Piston ring groove width

Piston ring	Standard
1st & 2nd	1.21 – 1.23 mm (0.0476 – 0.0484 in)
Oil	2.51 – 2.53 mm (0.0988 – 0.0996 in)

Piston ring thickness

Standard 1st & 2nd: 1.17 – 1.19 mm (0.046 – 0.047 in)

PISTON RING FREE END GAP AND PISTON RING END GAP

Before installing the piston rings, measure the free end gap of each ring with a vernier calipers.

Next, fit the ring in the cylinder, and measure each ring end gap with a thickness gauge.

If any ring has an excess end gap, replace the ring.

Piston ring free end gap

Service Limit 1st : 4.7 mm (0.19 in)

2nd: 6.0 mm (0.24 in)

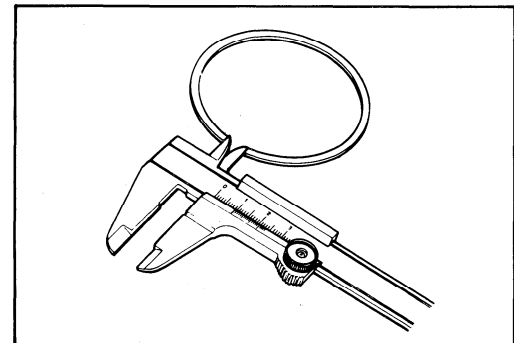
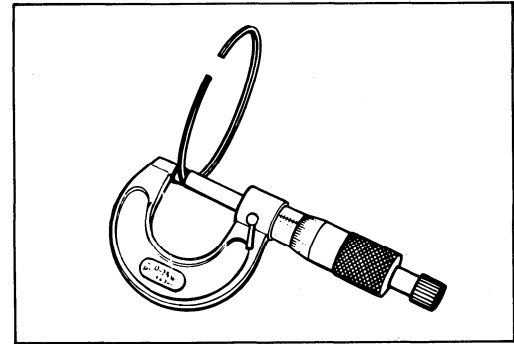
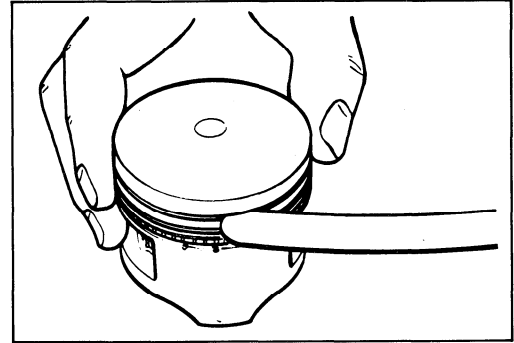

Piston ring end gap

Service Limit: 0.70 mm (0.028 in)

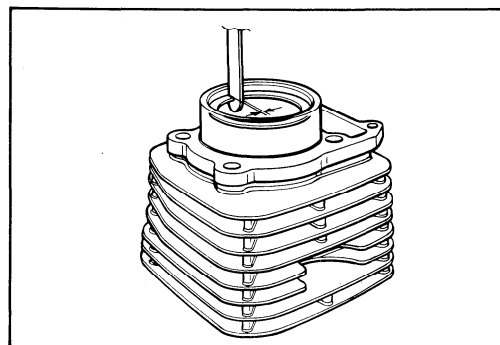
**OVERSIZE RINGS**

- **Oversize piston rings**

The following two types of oversize piston rings are used. They bear the following identification numbers.

Piston ring	1st	2nd
0.5 mm O.S.	50	50
1.0 mm O.S.	100	100

- **Oversize oil rings**

The following two types of oversize oil rings are used. They bear the following identification marks.

0.5 mm O.S.	Painted red
1.0 mm O.S.	Painted yellow

- **Oversize rail**

Just measure outside diameter to identify the side rail as there is no mark or numbers on it.

PISTON PIN BORE AND PIN

Measure the piston pin bore inside diameter with a caliper gauge, and measure the piston pin outside diameter with a micrometer. If the difference between these two measurements is more than the limits, replace both piston and piston pin.

Piston pin bore

Service Limit: 14.030 mm (0.5524 in)

Piston pin O.D.

Service Limit: 13.980 mm (0.5504 in)

09900-20605: Dial calipers (Not available in U.S.A.)

09900-20205: Micrometer (0 – 25 mm)

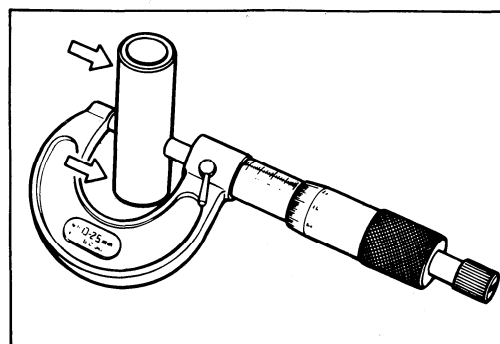
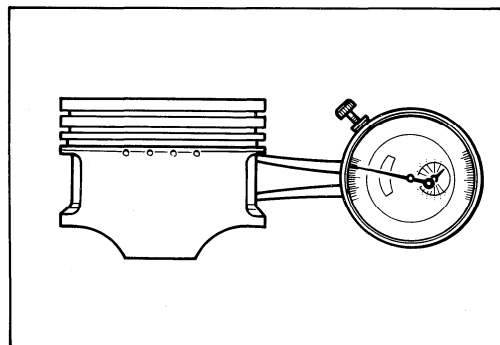
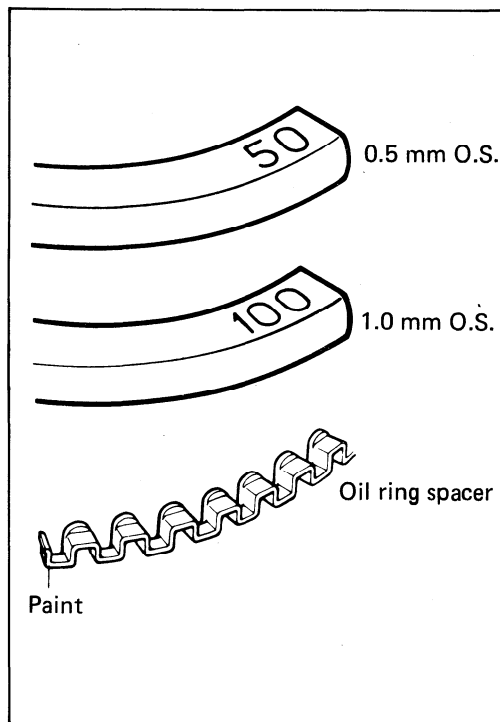

CONROD SMALL END I.D.

Measure the conrod small end inside diameter with a caliper gauge.

Service Limit: 14.040 mm (0.5528 in)

If the conrod small end bore inside diameter exceeds the limit, replace conrod.

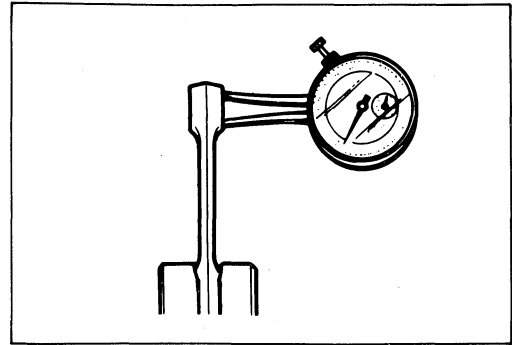

CONROD DEFLECTION AND CONROD BIG END SIDE CLEARANCE

Wear on the big end of the conrod can be estimated by checking the movement of the small end of the rod. This method can also check the extent of wear on the parts of the conrod's big end.

Service Limit: 3.0 mm (0.12 in)

09900-20606: Dial gauge (1/100 mm)

09900-20701: Magnetic stand (Not available in U.S.A.)

09900-21304: V-block (Not available in U.S.A.)

Push the big end of the conrod to one side and measure the side clearance with a thickness gauge.

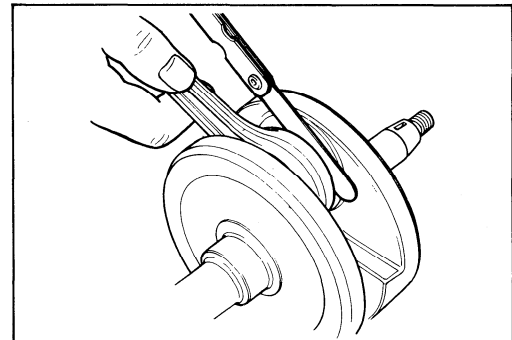
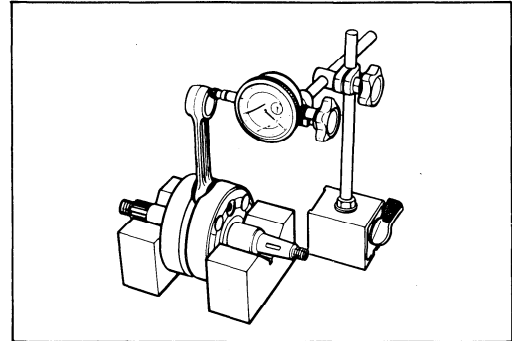

Standard	Service Limit
0.10 – 0.45 mm (0.0039 – 0.0177 in)	1.00 mm (0.039 in)

09900-20803: Thickness gauge

Where the limit is exceeded, replace crankshaft assembly or reduce the deflection and the side clearance to within the limit by replacing the worn parts—conrod, big end bearing and crankpin etc.

CRANKSHAFT RUNOUT

Support the crankshaft with "V" blocks as shown, with the two end journals resting on the blocks. Position the dial gauge, as shown, and rotate the crankshaft slowly to read the runout. Correct or replace the crankshaft if the runout is greater than the limit.

Service Limit: 0.05 mm (0.002 in)

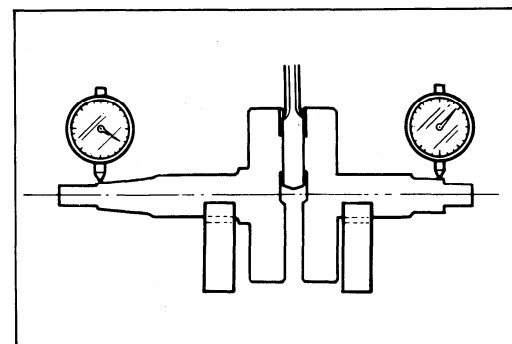

CLUTCH DRIVE PLATE

Measure the thickness and claw width of each drive plate with a vernier calipers. Replace the drive plates found to have worn down to the limit.

Item	Standard	Service Limit
Thickness	2.7 – 2.9 mm (0.106 – 0.114 in)	2.4 mm (0.094 in)
Claw width	11.8 – 12.0 mm (0.46 – 0.47 in)	11.0 mm (0.43 in)

09900-20101: Vernier calipers

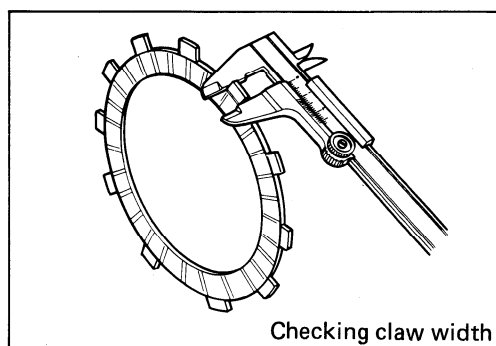
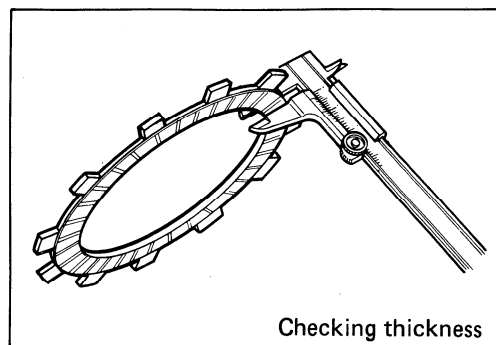

CLUTCH DRIVEN PLATE

Measure each driven plate for distortion with a thickness gauge. Replace the driven plates which exceed the limit.

Service Limit: 0.10 mm (0.004 in)

09900-20803: Thickness gauge

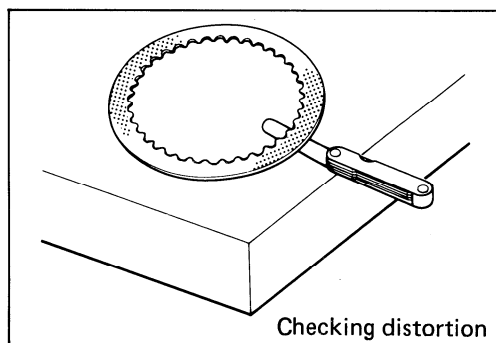

CLUTCH SPRING FREE LENGTH

Measure the free length of each coil spring with a vernier calipers, and determine the elastic strength of each. Replace any spring not within the limit.

Service Limit: 27.6 mm (1.09 in)

09900-20101: Vernier calipers

NOTE:

Clutch springs must be changed as a set and never individually.

CLUTCH SHOE

Inspect the shoes visually for chips, cracking, uneven wear, and burning, and check the depth of the grooves on the shoes. If there is no groove at any part of the shoes, replace them as a set.

NOTE:

Clutch shoes must be changed as a set and never individually.

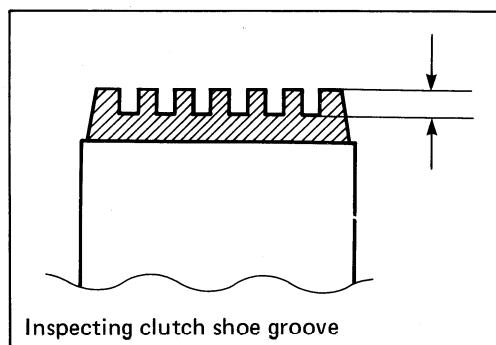
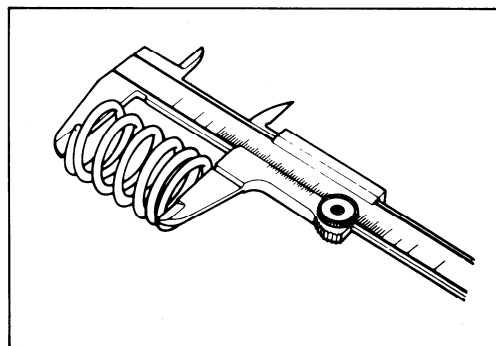

CLUTCH WHEEL

Inspect visually the condition of the inner clutch wheel surface for scuffing, scratches, cracks or uneven wear. If the surface shows any abnormality replace the clutch wheel with a new one.

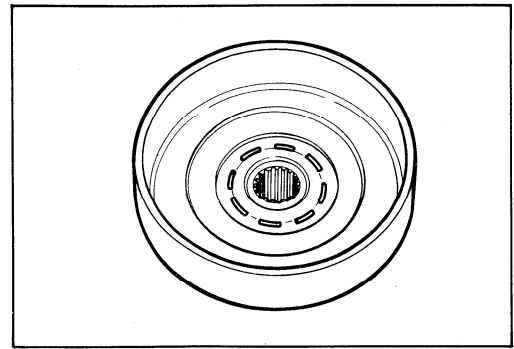

ONE-WAY CLUTCH

Inspect the one-way clutch ① by hand while fixing it in the clutch housing. Rotate the inner race ② by hand to inspect that inner race turns to one direction only and never turns to the opposite direction.

If the inner race turns both directions or is locked, replace the one-way clutch assembly with a new one.

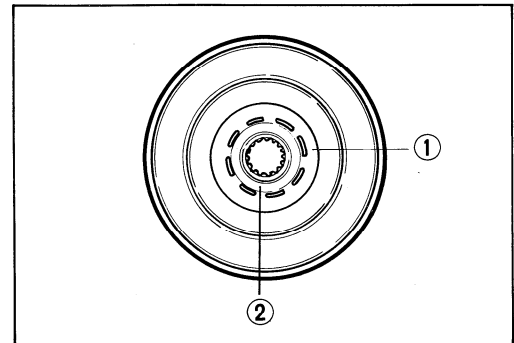

CLUTCH COVER AND CLUTCH ADJUSTER DISASSEMBLY

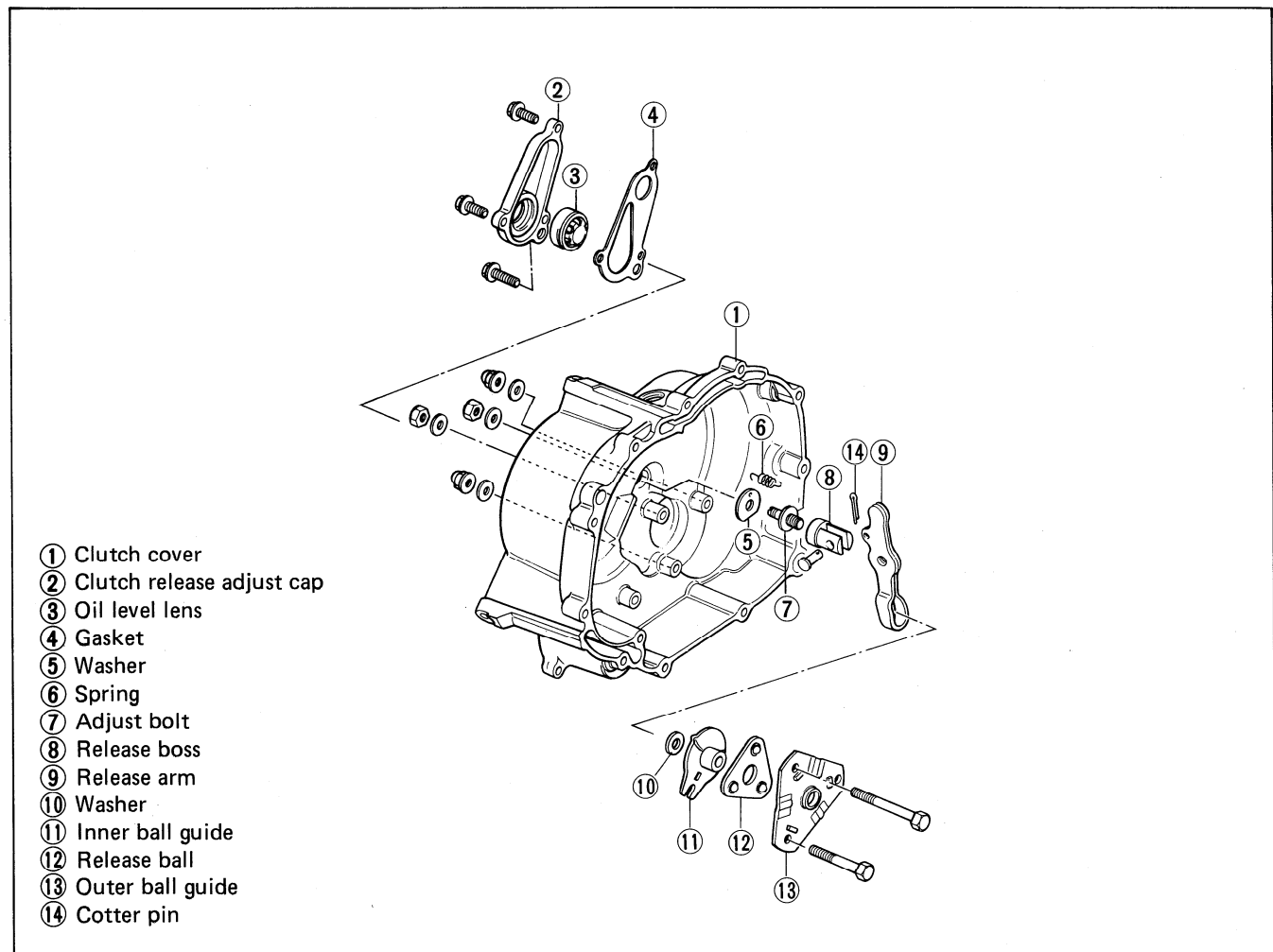

- Remove the clutch release adjuster cap.

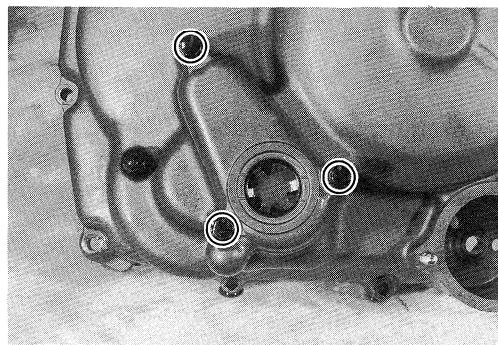

- Remove the clutch release outer guide, release ball, inner guide and washer.

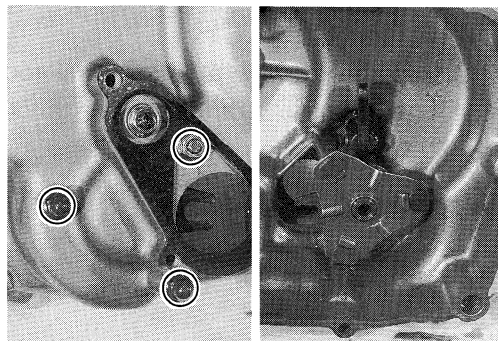

- Remove the pin and release arm.
- Remove the lock nut and release adjuster.

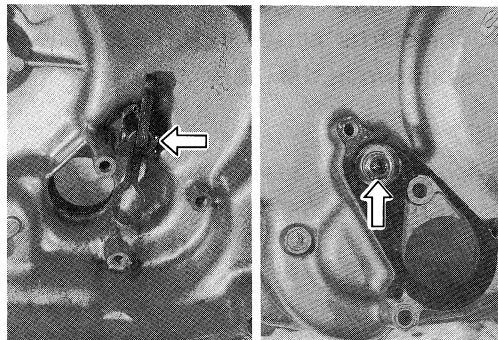

CLUTCH RELEASE BALL

Rotate the balls by hand to inspect for an abnormal noise and a smooth rotation. Replace the clutch release ball if there is anything unusual.

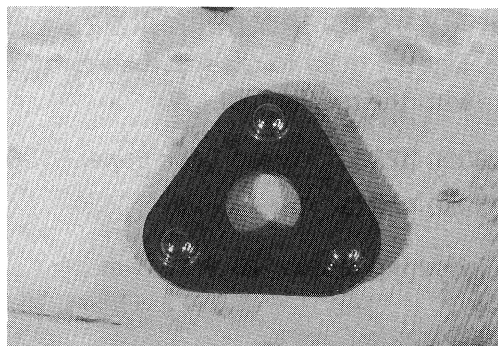

REASSEMBLY

- Finger tighten the release arm boss ① to the adjust bolt ②.
- Install the spring, release arm and cotter pin as shown in illustration.

NOTE:

Always use a new cotter pin.

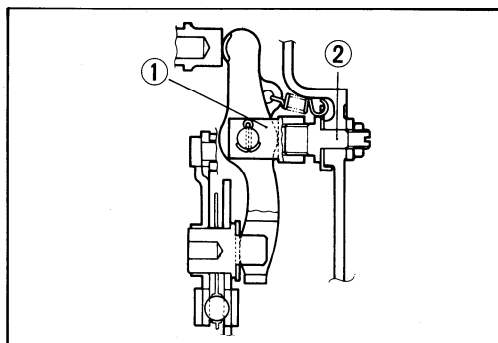

3-31 ENGINE

- Install the clutch release inner guide, release ball and release outer guide, and tighten the nuts ① to the specified torque.

Tightening torque: 10 – 12 N·m

(1.0 – 1.2 kg·m, 7.0 – 8.5 lb·ft)

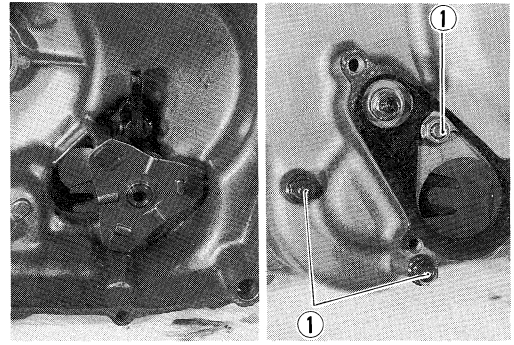

STARTER CLUTCH

- Clamp the rotor with the special tool and a vice taking care not to damage it and remove the three allen bolts with a "T" type hexagon wrench.

09930-44913: Rotor holder

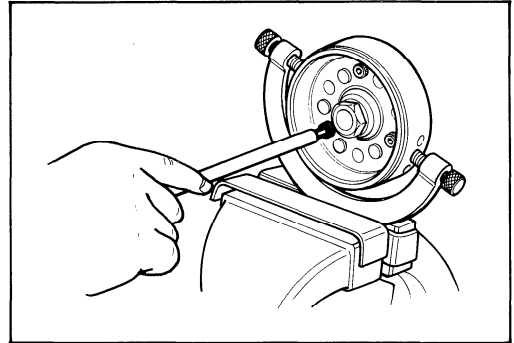

- The starter clutch must be installed in the proper direction as shown in the illustration.

NOTE:

When installing the starter clutch to the rotor, face the cut ② of the cage to the rotor.

- Apply engine oil to the starter clutch.

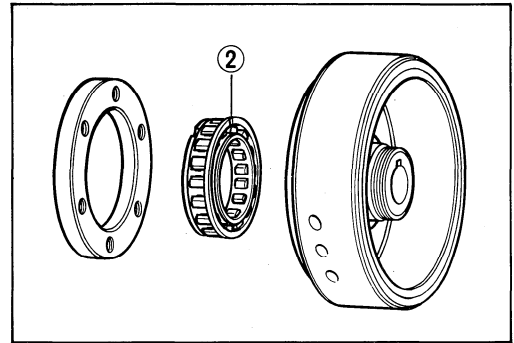

- Apply **THREAD LOCK SUPER "1303"** to the allen bolts. Tighten them to the specified torque while holding the rotor with the special tool.

99000-32030: Thread Lock Super "1303"

09930-44913: Rotor holder

Tightening torque: 23 – 28 N·m

(2.3 – 2.8 kg·m, 16.5 – 20.0 lb·ft)

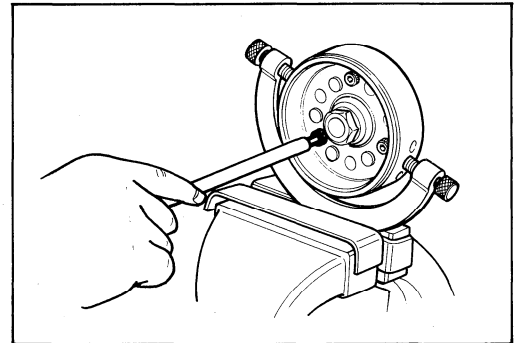

- Install the starter gear ③ to the starter clutch.
- Check that the rotor ④ turns in the direction of the arrow ⑤ on the rotor while holding the starter gear ③, and that the rotor ④ never turns in the opposite direction of the arrow ⑤.

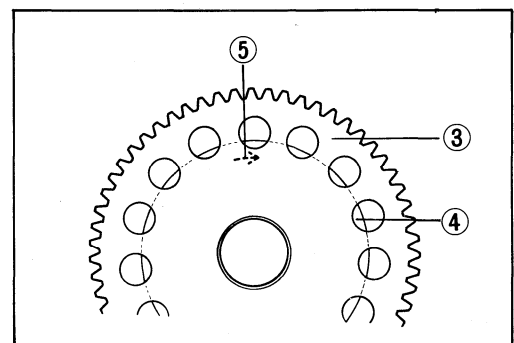

MAGNETO

Fit the stator on the magneto cover and apply a small quantity of THREAD LOCK "1342" to the stator mounting bolts.

99000-32050: Thread Lock "1342"

NOTE:

Bond No. 1207B/1215 should be applied to the groove of magneto lead wire grommet.

99104-31140: SUZUKI BOND No. 1207B (U.S.A.)

99000-31110: SUZUKI BOND No. 1215 (Others)

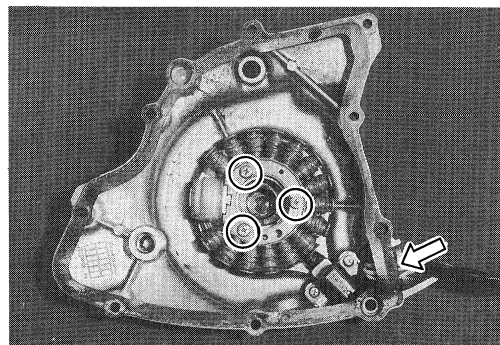

OIL PUMP

CAUTION:

The oil pump case securing screw is applied with SUZUKI THREAD LOCK SUPER "1303". If an attempt is made to overhaul the oil pump assembly, the screw may be damaged. As a replacement, only the oil pump unit is available.

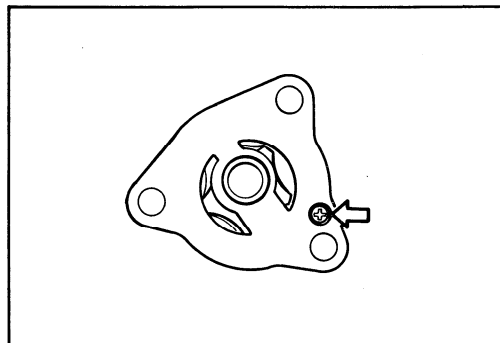

TRANSMISSION

DISASSEMBLY

Disassemble the transmission gears as shown in the illustration.

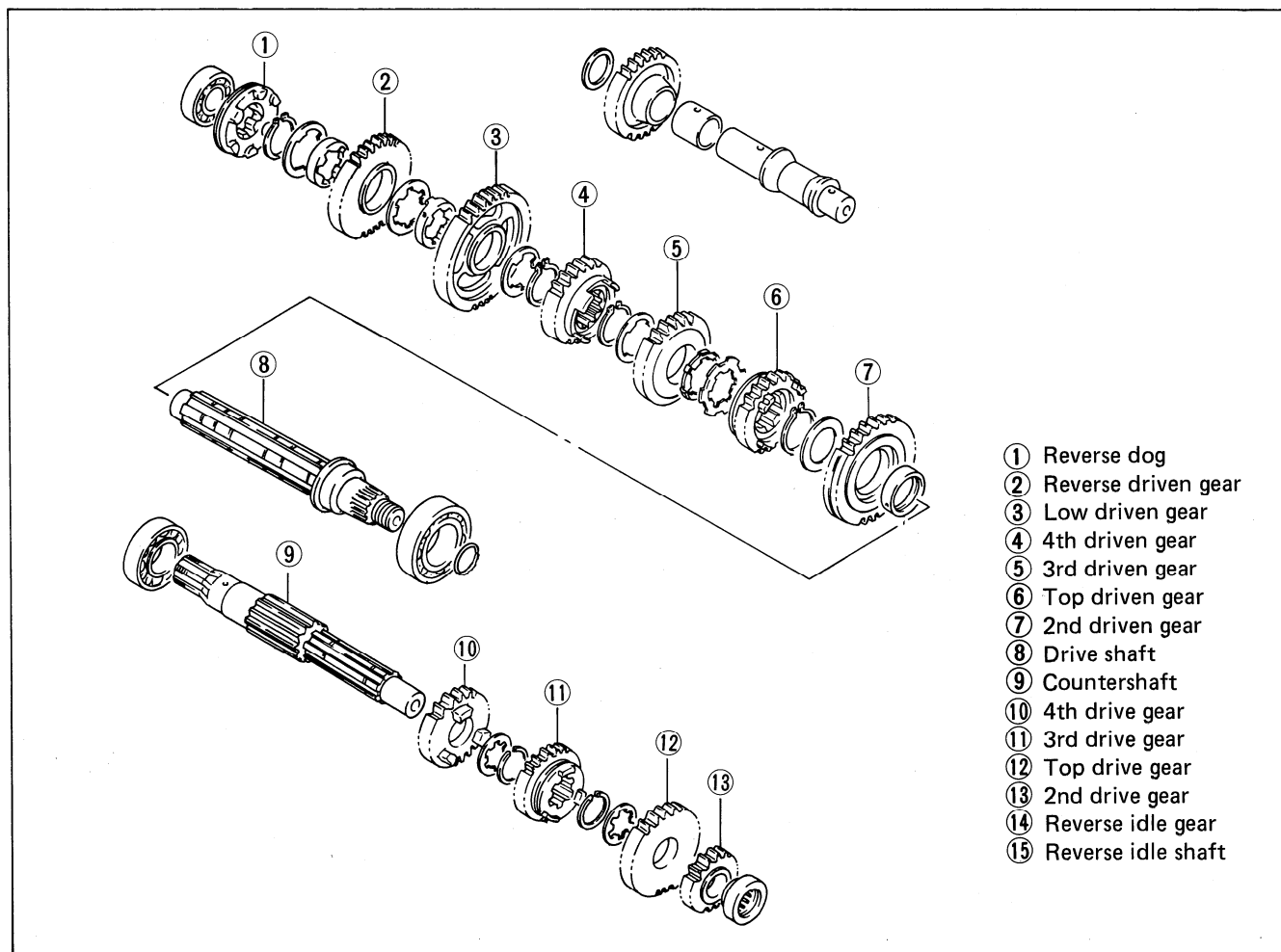

GEARSHIFT FORK AND GEAR

Check the gearshift for clearance in the groove of its gear with a thickness gauge. If the clearance limit is exceeded by any of the four gears, determine whether the gear or the gearshift fork should be replaced by measuring the thickness and groove width.

Item	Standard	Limit
Shift fork to groove clearance	0.10 – 0.30 mm (0.004 – 0.012 in)	0.50 mm (0.020 in)

Shifting fork groove width		
Standard	No. 1, No. 2 & No. 3	4.50 – 4.60 mm (0.177 – 0.181 in)
	Reverse	4.00 – 4.10 mm (0.157 – 0.161 in)

Shifting fork thickness		
Standard	No. 1, No. 2 & No. 3	4.30 – 4.40 mm (0.169 – 0.173 in)
	Reverse	3.80 – 3.90 mm (0.150 – 0.154 in)

09900-20803: Thickness gauge

09900-20101: Vernier calipers

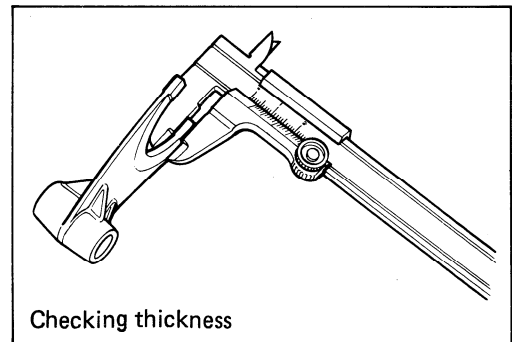
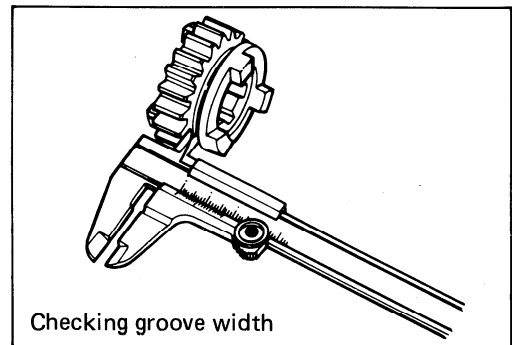
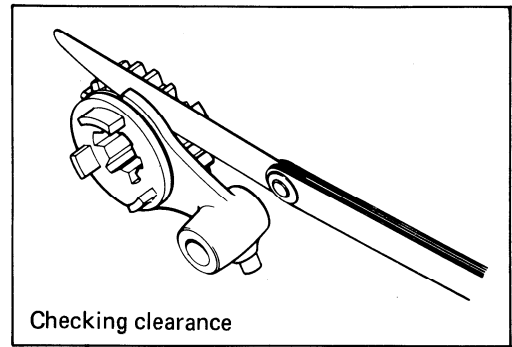

REASSEMBLY

Assemble the countershaft and driveshaft, in the reverse order of disassembly.

Pay attention to the following points:

NOTE:

In reassembling the transmission, attention must be given to the locations and positions of washers and circlips. The cross sectional view given here will serve as a reference for correctly mounting the gears, washers and circlips.

CAUTION:

- * Never reuse a circlip. After a circlip has been removed from a shaft, the removed circlip should be discarded and a new circlip must be installed.
- * When installing a new circlip, care must be taken not to expand the end gap larger than required to slip the circlip over the shaft.
- * After installing a circlip, always insure that it is completely seated in its groove and securely fitted.

When installing a circlip, pay attention to the direction of the thrust. Fit it to the side where the thrust is as shown in the figure with the rounded side against the gear surface.

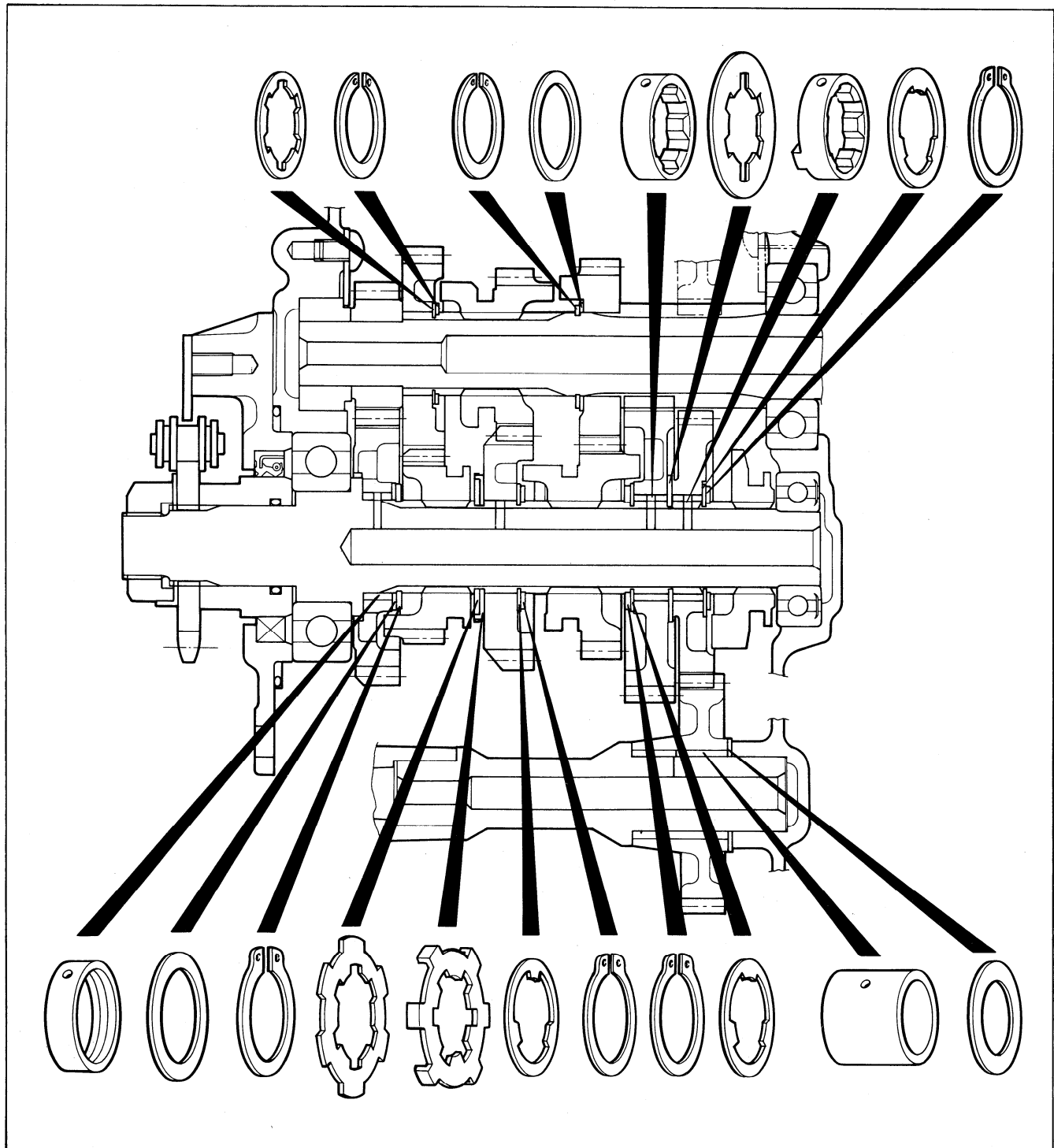
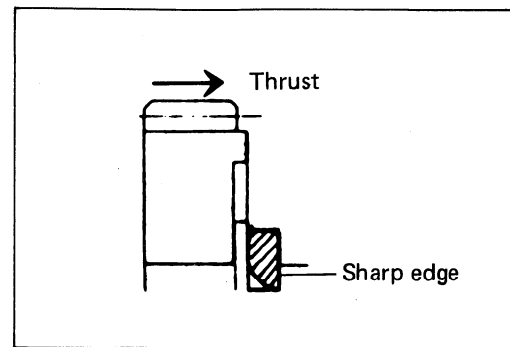

MOUNTING THE 2ND DRIVE GEAR

- Press-fit 2nd drive gear onto the countershaft.

NOTE:

Before reassembling, coat the internal face of the 2nd drive gear with **THREAD LOCK SUPER "1333B"** and install it.

99000-32020: Thread Lock Super "1333B"

NOTE:

Take care not to smear **TOP** drive gear with **THREAD LOCK SUPER "1333B"**.

NOTE:

- * After mounting the 2nd drive gear, check that **TOP** drive gear spins smoothly by moving it with your fingers.
- * This procedure may be performed only twice before shaft replacement is required.

- When mounting the 3rd driven gear on the drive shaft, insert lock washer No. 2 ① onto the drive shaft, and turn and fit into the groove. Then, fit the lock washer No. 1 ② in the lock washer No. 2.

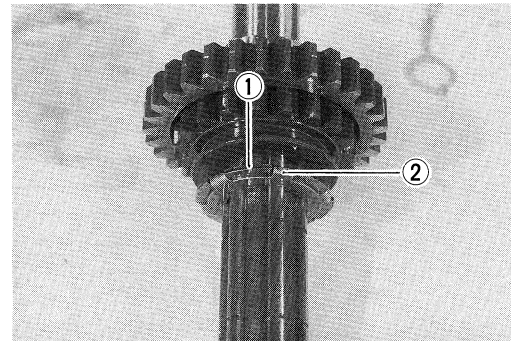
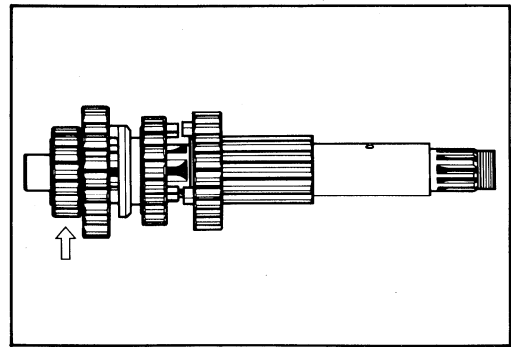

MOUNTING THE DRIVEN GEAR BUSHING

- When mounting the low driven gear bushing ③ and reverse driven gear bushing ④ onto the drive shaft, align the oil holes.

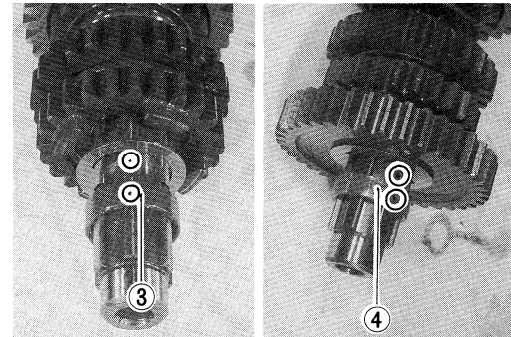

CRANKCASE BEARING

Inspect the play of bearing inner ring by hand while mounted in the case. Rotate the inner ring by hand to inspect if any abnormal noise occurs or smoothly. Replace the bearing if there is something unusual.

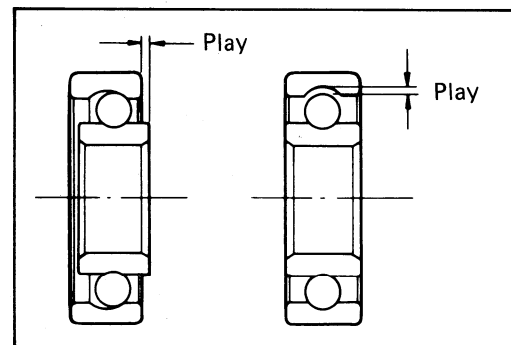

ENGINE REASSEMBLY

Reassembly is generally performed in the reverse order of disassembly, but there are numbers of reassembling steps that demand or reserve detailed explanation or emphasis. These steps will be taken up for respective parts and components.

NOTE:

Apply engine oil to each running and sliding part before reassembling.

OIL SEALS

Apply grease to the lip of oil seals.

99000-25030: SUZUKI Super grease "A" (U.S.A.)

99000-25010: SUZUKI Super grease "A" (Others)

NOTE:

Replace the oil seals with new ones every disassembly to prevent oil leakage.

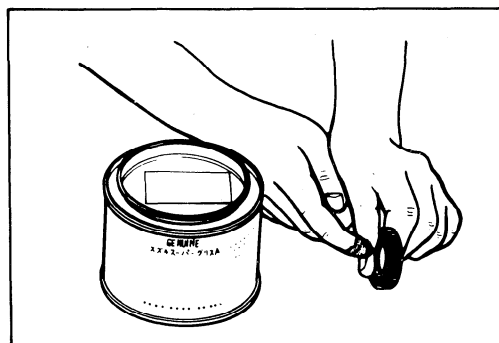

CRANKSHAFT

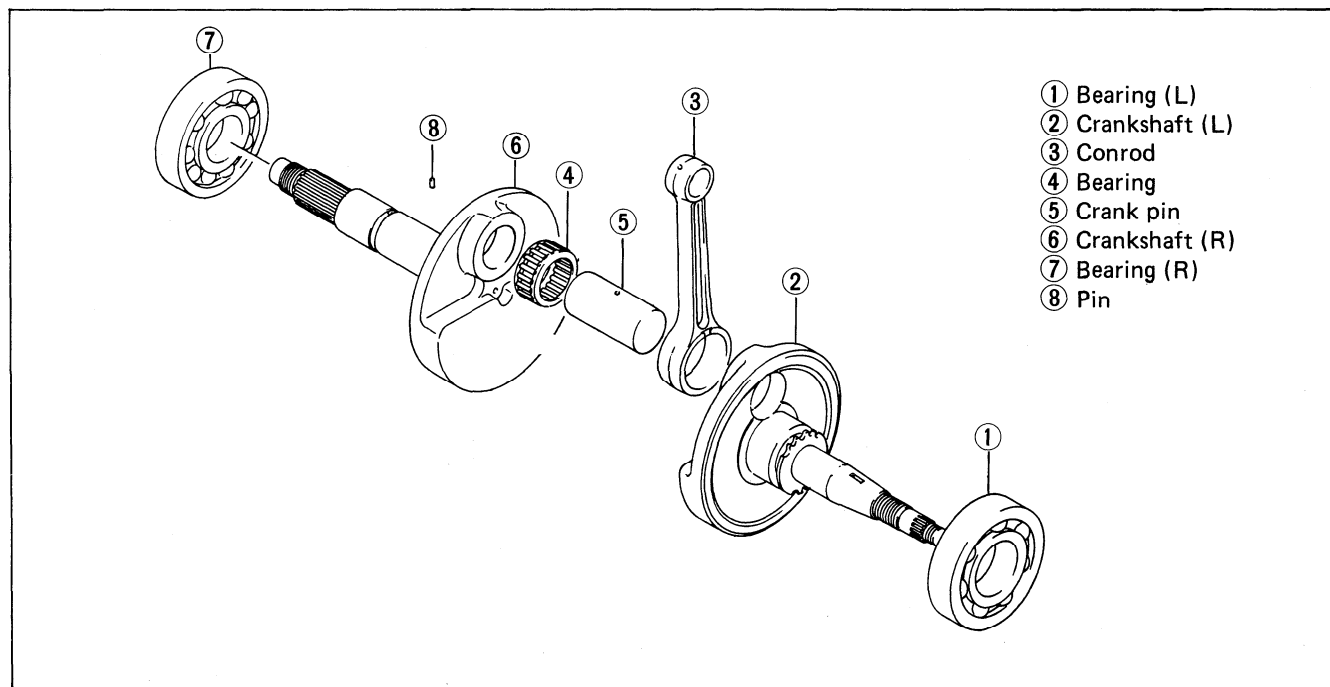

- Decide the width between the webs referring to the figure below when rebuilding the crankshaft.

STD width between webs: 53.0 ± 0.1 mm
(2.087 ± 0.004 in)

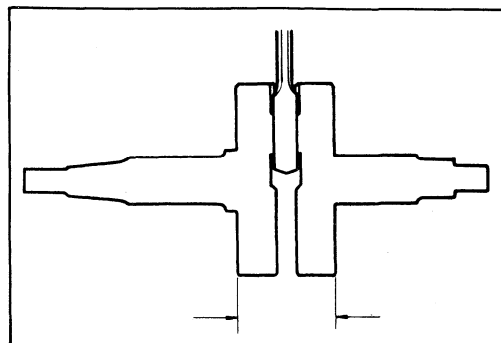

3-37 ENGINE

- When mounting the crankshaft in the crankcase, it is necessary to pull its left end into the crankcase with the special tools.

09910-32812: Crankshaft installer

09940-53111: Crankshaft installer spacer

CAUTION:

Never fit the crankshaft into the crankcase by striking it with a plastic hammer.

Always use the special tool, otherwise crankshaft alignment accuracy will be affected.

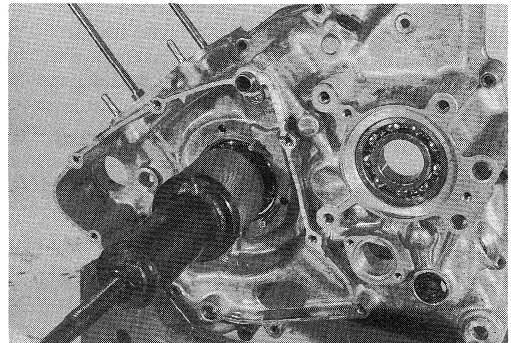
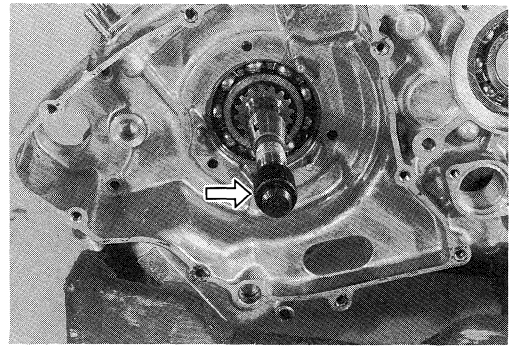

GEARSHIFT CAM AND FORK

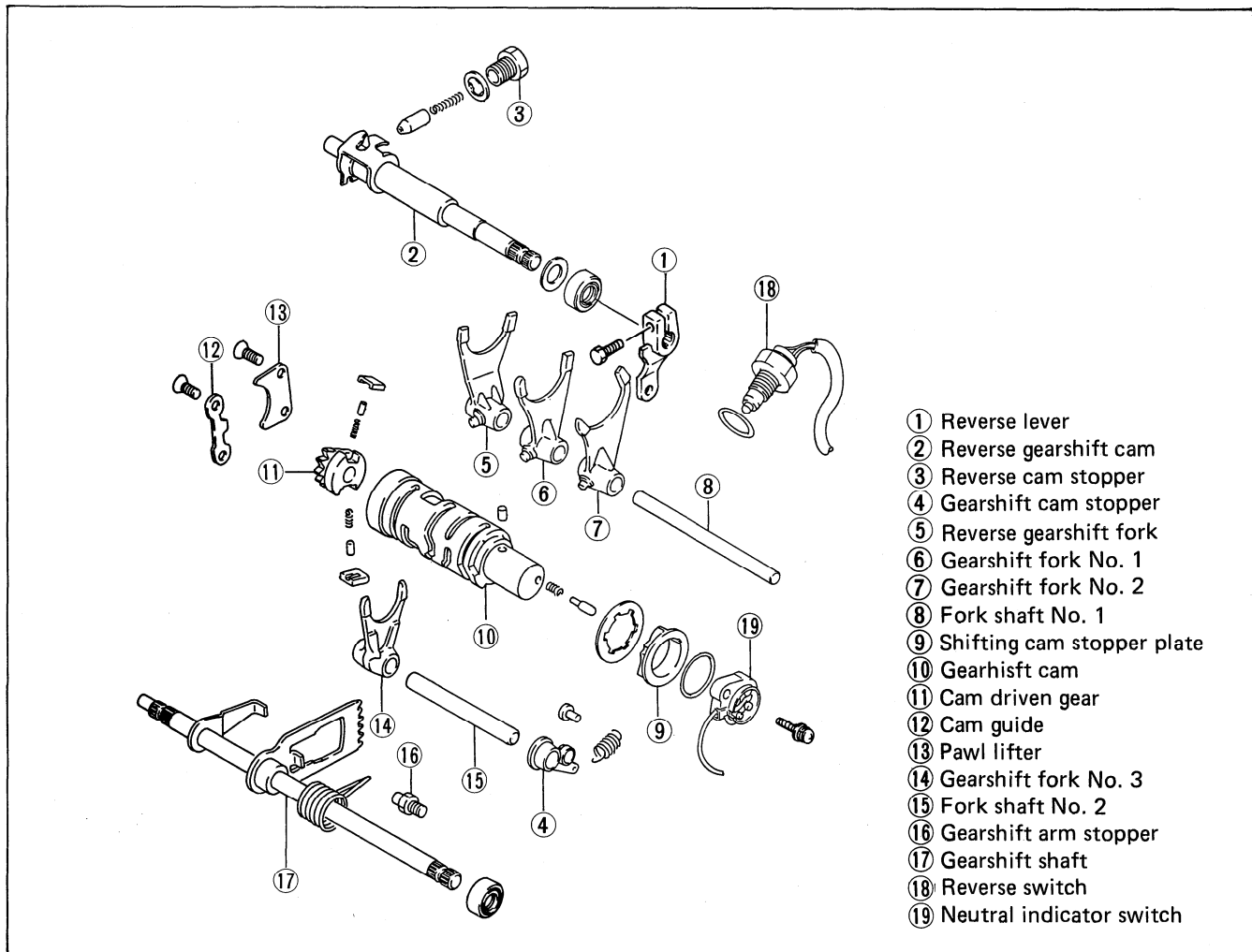

- When fitting the cam stopper plate on the gearshift cam, align the pin groove ① with the pin ②.

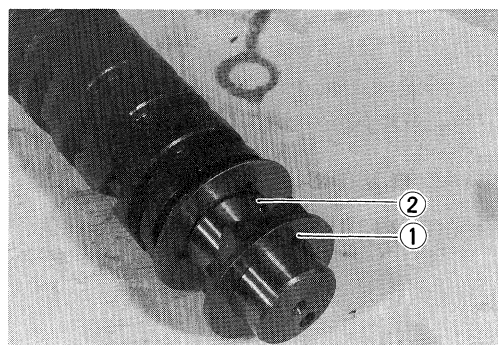

- After fitting the gearshift forks ③, ④, ⑤ and ⑥ into the gearshift grooves, fit the gearshift cam ⑦ and reverse gearshift shaft ⑧ on the crankcase.

NOTE:

Four kinds of gearshift forks, ③, ④, ⑤ and ⑥ are used. They resemble each other very closely in external appearance and configuration.

Carefully examine the illustration for correct installing positions and directions.

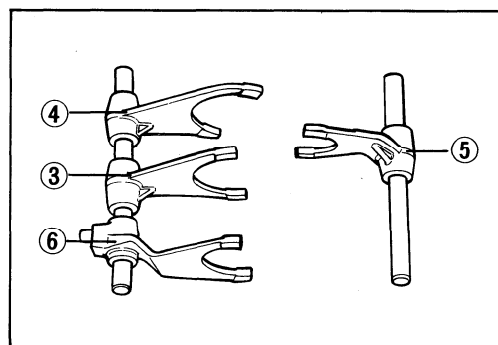

- ③ For 4th driven gear (No. 1)
- ④ For top driven gear (No. 2)
- ⑤ For 3rd drive gear (No. 3)
- ⑥ For Reverse dog

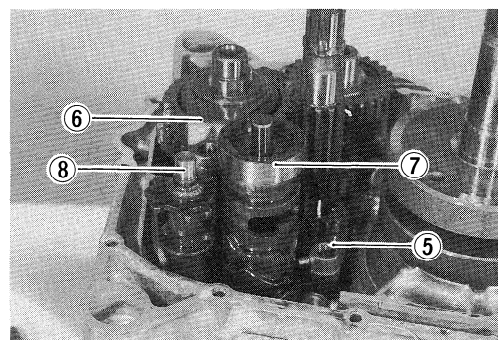

- Hook the cam stopper spring.

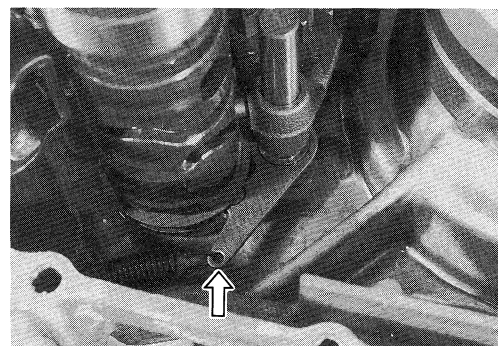

CRANKCASE

When reassembling the crankcase pay attention to the following.

- Remove sealant material on the fitting surfaces of right and left halves of crankcase and thoroughly remove oil stains.
- Fit the dowel pins ⑨ and O-ring ⑩ on the left half.
- Apply engine oil to the big end of the crankshaft conrod and all parts of the transmission gears.

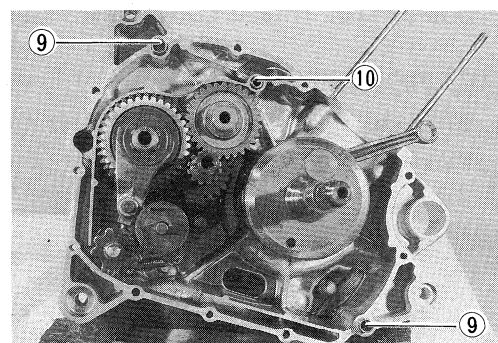

- Apply SUZUKI BOND No. 1207B/1215 uniformly to the fitting surface of the right half of the crankcase, and assemble the cases within few minutes.

99104-31140: SUZUKI Bond No. 1207B (U.S.A.)

99000-31110: SUZUKI Bond No. 1215 (Others)

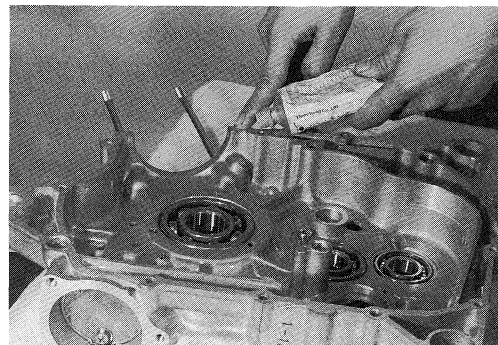

- After the crankcase bolts have been tightened, check if drive shaft and countershaft rotate smoothly.
- If a large resistance is felt to rotation, try to free the shafts by tapping the drive shaft or countershaft with a plastic hammer.

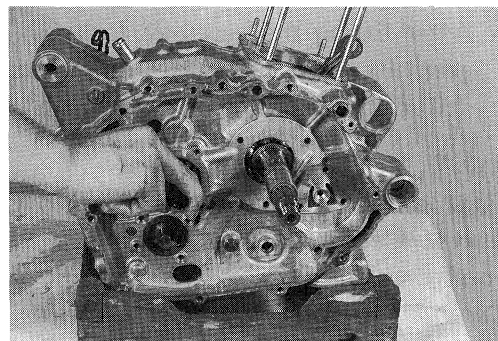

REVERSE CAM STOPPER AND SWITCH

- Tighten the stopper bolt ① and reverse switch ② to the specified torque.

Tightening torque ① : 18 – 28 N·m
(1.8 – 2.8 kg·m, 13.0 – 20.0 lb-ft)

② : 20 – 25 N·m
(2.0 – 2.5 kg·m, 14.5 – 18.0 lb-ft)

NOTE:

Replace the reverse switch O-ring with a new one.

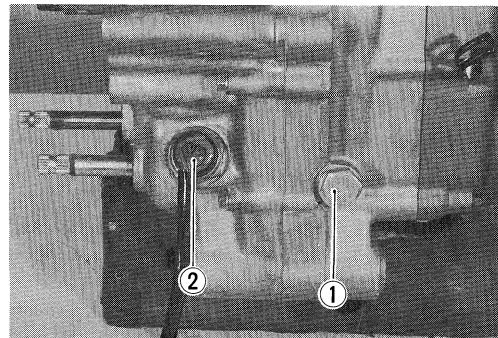

CAM DRIVEN GEAR

- When installing the gearshift pawls into the cam driven gear. The large shoulder A must face to the outside as shown in the illustration.

Install the cam guide ③ and pawl lifter ④. Apply a small quantity of THREAD LOCK SUPER "1303/1322" to the threaded parts of the securing screws.

99000-32030: Thread Lock Super "1303" (U.S.A.)

99000-32110: Thread Lock Super "1322" (Others)

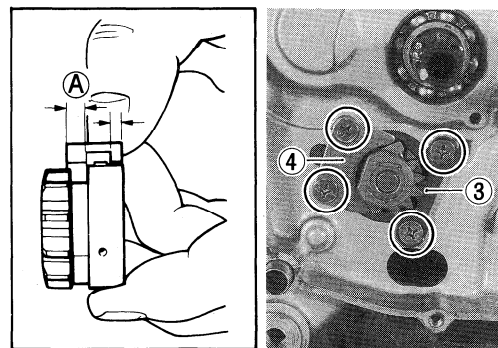

GEARSHIFT SHAFT

- Fit a spring to the gearshift shaft correctly as shown in the illustration.

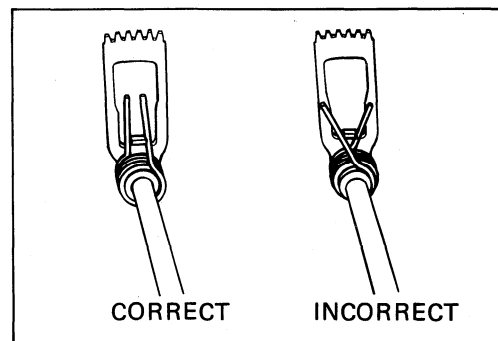

- Install the gearshift shaft. Match the center teeth of the gear on the gearshift shaft with the center teeth on the cam driven gear as shown.

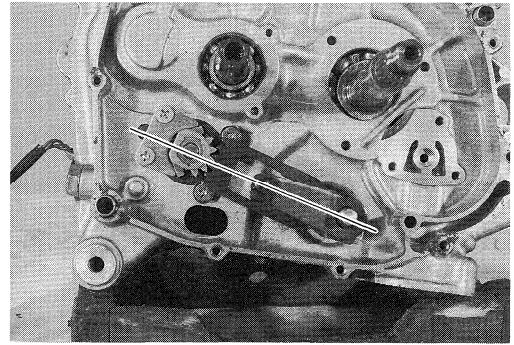

OIL PUMP

- Before mounting the oil pump, apply engine oil to the sliding surfaces of the case, outer rotor, inner rotor and shaft.
- Apply a small quantity of THREAD LOCK "1342" to the threaded parts of oil pump mounting screws.

99000-32050: Thread Lock "1342"

- Tighten the oil pump mounting screws.

Tightening torque: 5 – 8 N·m (0.5 – 0.8 kg·m, 3.5 – 6.0 lb·ft)

- When installing the oil pump driven gear, align the pin ① with groove ②.

NOTE:

After mounting the oil pump in the crankcase, rotate the pump driven gear by hand to see if it turns smoothly.

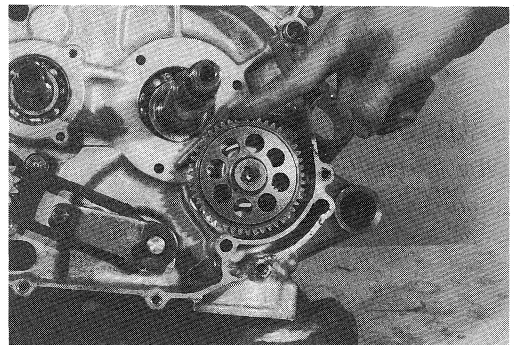
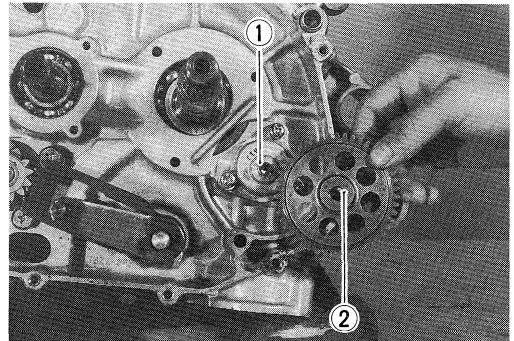
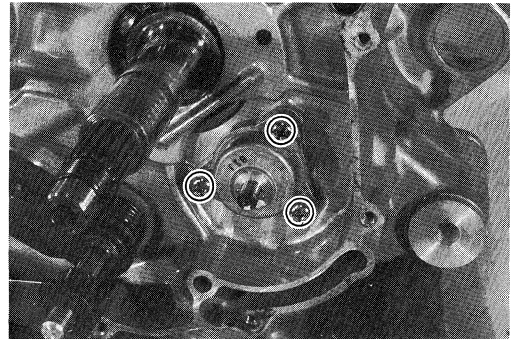

- When installing the oil pump drive gear, align the pin ③ with groove ④.

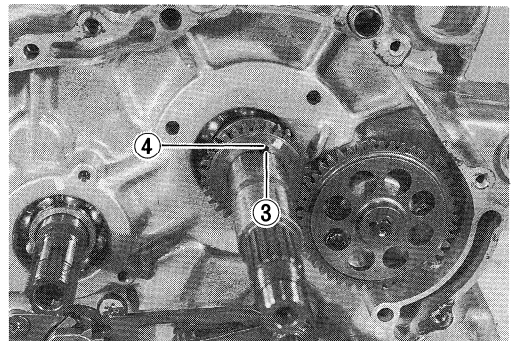

CLUTCH

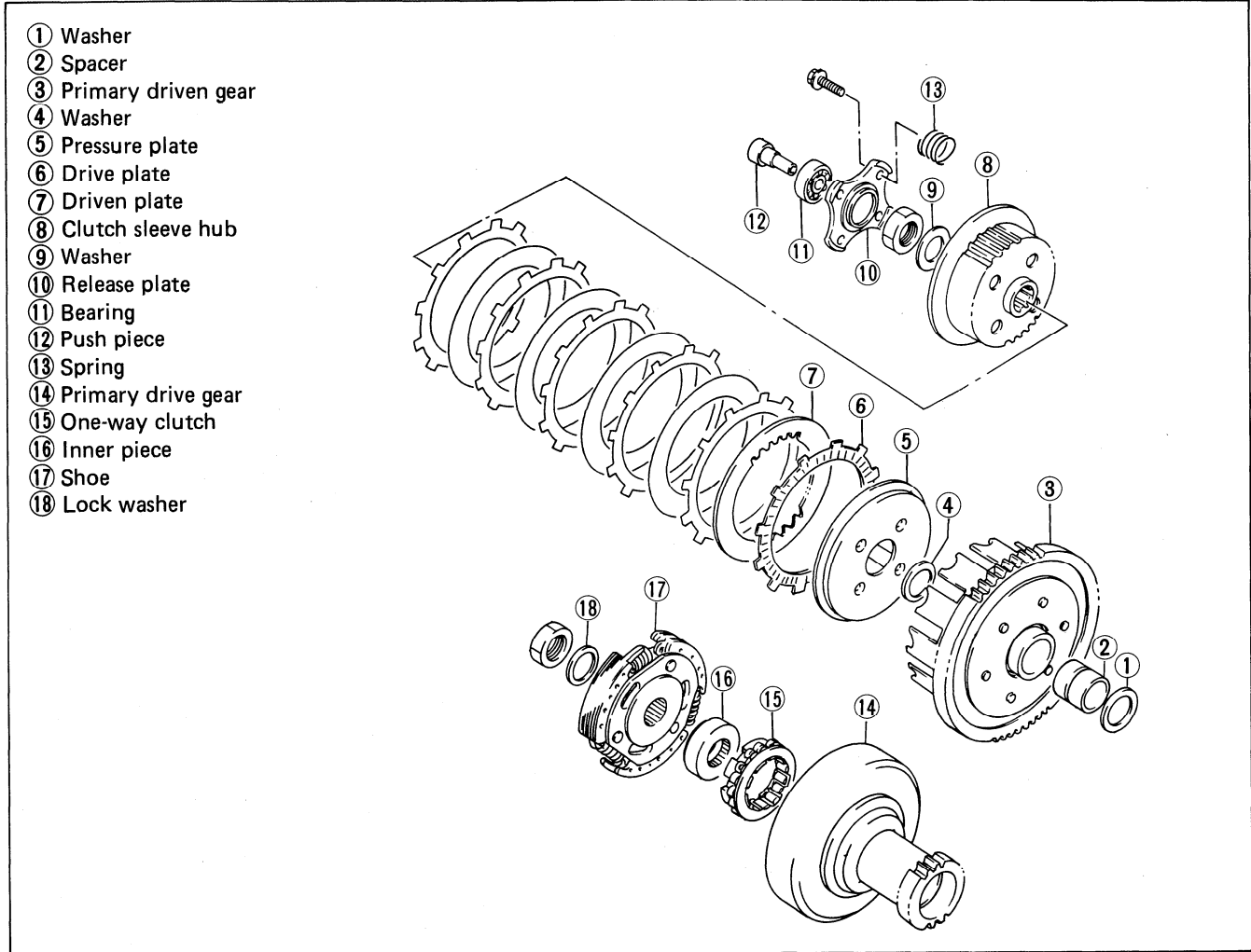

- Install the clutch plates to the clutch sleeve hub and engage the clutch pressure plate to the sleeve hub.

CAUTION:

When installing the clutch pressure plate to the sleeve hub, align the punched marks ① and ②.

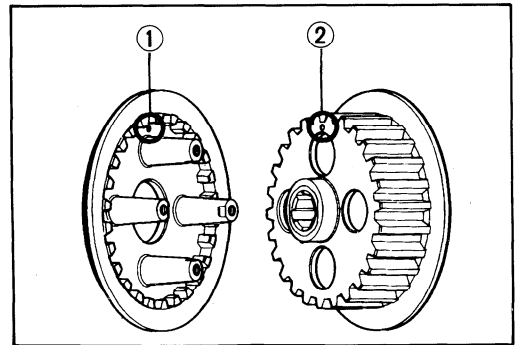

- Tighten the clutch sleeve hub nut to the specified torque with the special tool.

09920-53730: Clutch sleeve hub holder

Tightening torque: 60 – 80 N·m
 (6.0 – 8.0 kg·m, 43.5 – 58.0 lb·ft)

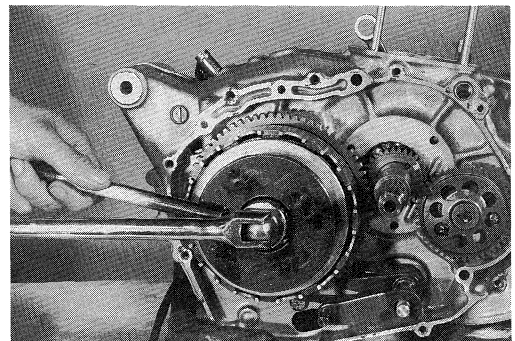

- Install the clutch springs and clutch release plate.
- Tighten the clutch spring bolts diagonally.

NOTE:

After tightening the clutch spring bolts, make sure to have no clearance between clutch plates.

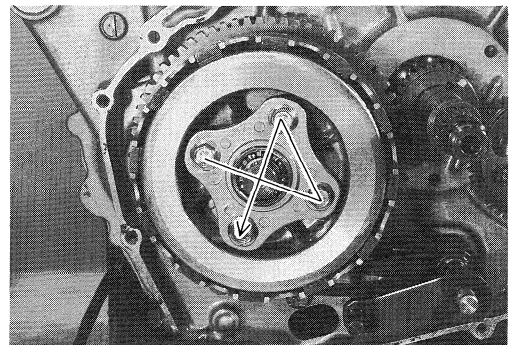

- When installing the one-way clutch, face the arrow mark of the one-way clutch to the inside.
- The one-way clutch and inner piece must be installed in the proper direction as shown in the illustration.
- Apply engine oil to the one-way clutch.

NOTE:

After installing the inner piece, make sure that the clutch wheel turns counter-clockwise freely and never turns clockwise.

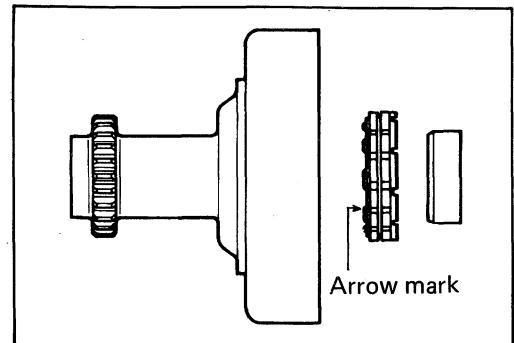

- Apply THREAD LOCK SUPER "1303/1305" to the shoe shoe nut and tighten it to the specified torque with the special tool.

NOTE:

Shoe nut has left-hand thread.

99000-32030: Thread Lock Super "1303" (U.S.A.)

99000-32100: Thread Lock Super "1305" (Others)

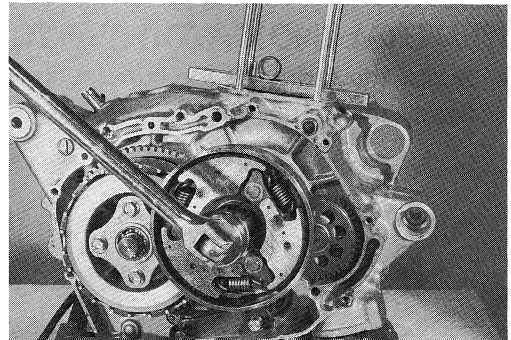

Tightening torque: 110 – 130 N·m
(11.0 – 13.0 kg·m, 79.5 – 94.0 lb-ft)

09910-20115: Conrod holder

- Fit the dowel pins and oil jets.

NOTE:

Check the number of the oil jets and install them to the proper position.

- ① # 14 oil jet
- ② # 16 oil jet

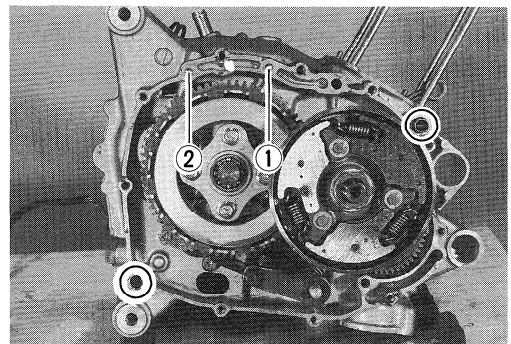

- After installing the clutch cover, check if clutch release arm pin ③ and pin guide ④ are properly.

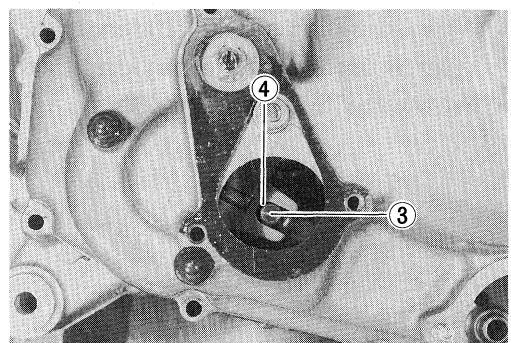

- Tighten the clutch cover bolts.

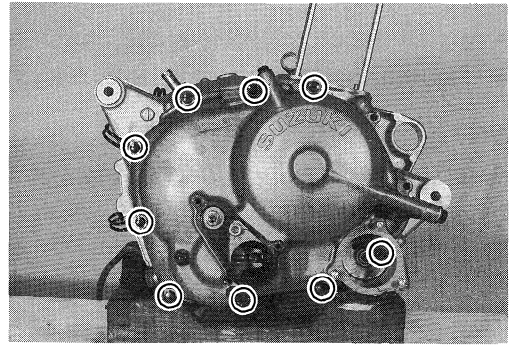

- Loosen the release adjusting bolt until resistance is felt, then tighten it 1/8 turn.
- Secure the lock nut.

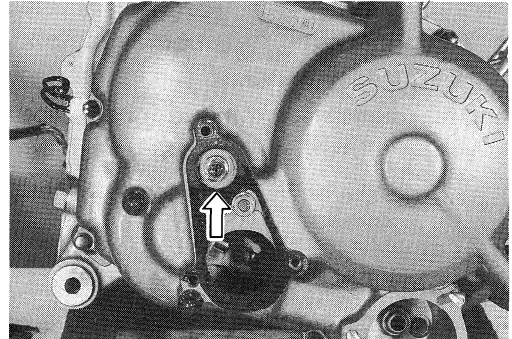

NEUTRAL INDICATOR SWITCH

- Install the spring ① and contact ②.
- Install the switch body with a new O-ring.

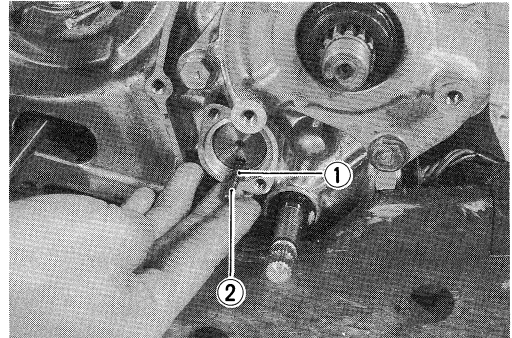

STARTER CLUTCH AND MAGNETO COVER

- Engage the cam chain on the sprocket.

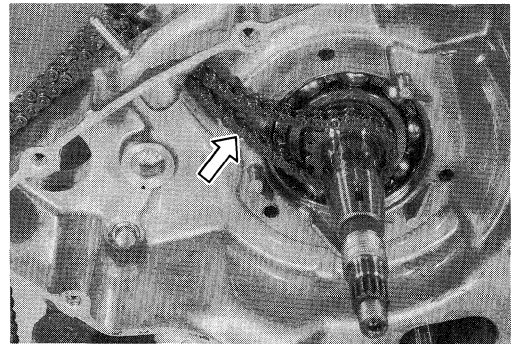

- After installing bearing and starter clutch gear, degrease the tapered portion of the crankshaft and also the rotor.
- Fit the key ③ to the crankshaft.

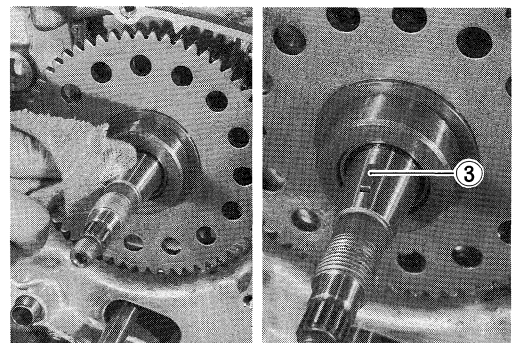

- Apply THREAD LOCK SUPER "1303/1305" to the rotor nut.

99000-32030: Thread Lock Super "1303" (U.S.A.)

99000-32100: Thread Lock Super "1305" (Others)

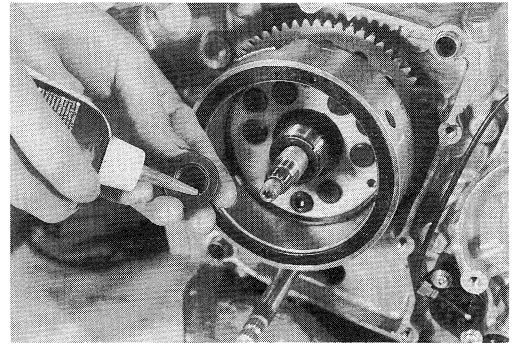

- Tighten the rotor nut to the specified torque with the special tool.

09930-44913: Rotor holder

Tightening torque: 145 – 175 N·m
(14.5 – 17.5 kg·m, 105.0 – 126.5 lb-ft)

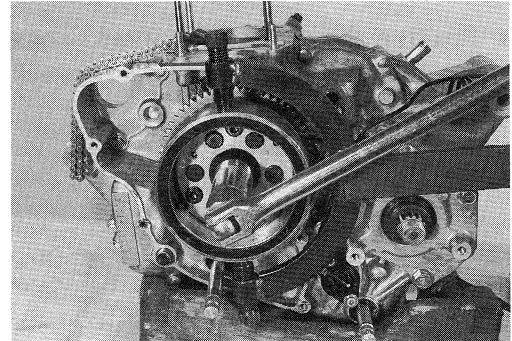

- Install the starter idle gear and shaft.
- Tighten the drive shaft oil seal retainer mounting bolts to the specified torque.

Tightening torque: 20 – 28 N·m
(2.0 – 2.8 kg·m, 14.5 – 20.0 lb-ft)

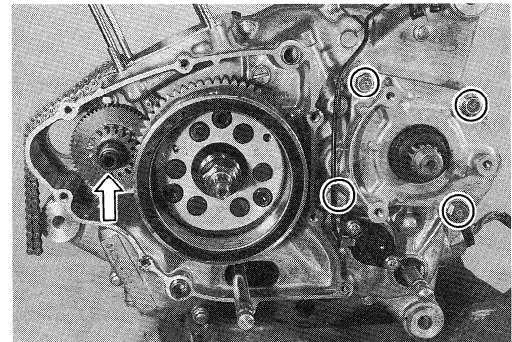

OIL RING AND PISTON RING

- Install the spacer ① into the bottom ring groove first. Then install both side rails ②, one on each side of the spacer. The spacer and side rails do not have a specific top or bottom when they are new. When reassembling used parts, install them in their original place and direction.

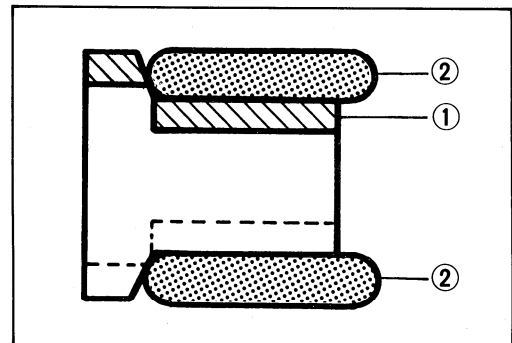

- Top ring and 2nd ring differ in the shape of ring face and the face of top ring is chromeplated whereas that of 2nd ring is not. The color of 2nd ring appears darker than that of the top one.

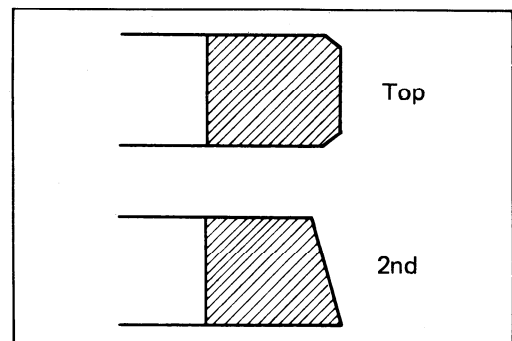

- 2nd ring has the letter "R" marked on the top. Be sure to bring the marked side to the top when fitting it to the piston.

NOTE:

Top ring makes no difference either way.

- Position the gaps of the three rings as shown. Before inserting piston into the cylinder, check that the gaps are so located.

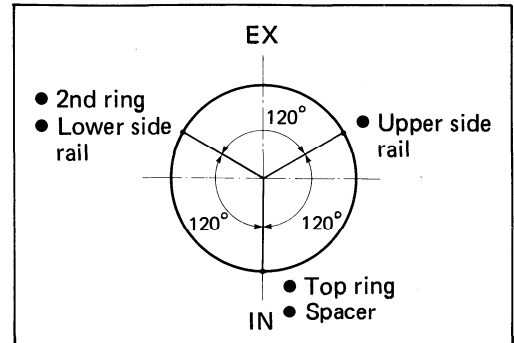
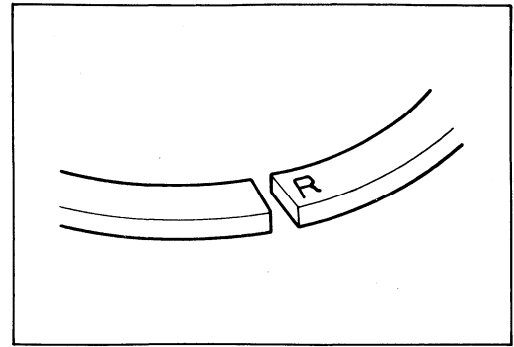

PISTON

The following are reminders for piston installation:

- Apply a small quantity of SUZUKI MOLY PASTE onto the piston pin.

99000-25140: SUZUKI Moly paste

- Place a clean rag over the cylinder base to prevent the piston pin circlips from dropping into crankcase, and then fit the piston pin circlip with long-nose pliers.

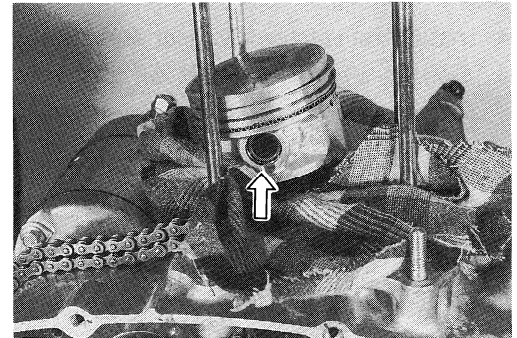

CAUTION:

Use a new piston pin circlip to prevent circlip failure which will occur with a bent one.

- When fitting the piston, turn triangle mark ① on the piston head to exhaust side.

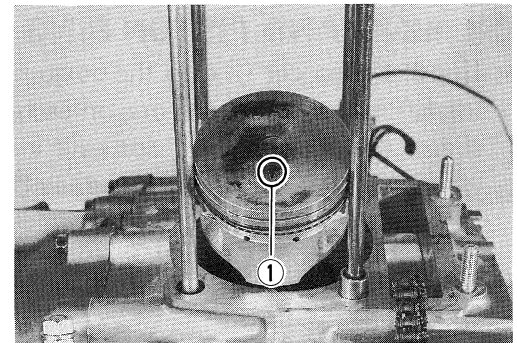

CYLINDER

Before mounting the cylinder block, oil the big end and small end of the conrod and also the sliding surface of the piston.

- Fit the dowel pins ② and new gasket.

CAUTION:

To prevent oil leakage, do not use the old gasket again, always use a new one.

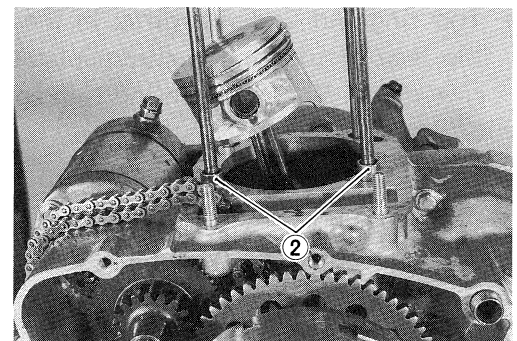

- Hold each piston ring with the piston ring sections positioned and put them into the cylinder.
Confirm that the piston rings are properly engaged in the cylinder skirt.

NOTE:

When mounting the cylinder, after attaching camshaft drive chain ①, keep the camshaft drive chain taut. The camshaft drive chain must not be caught between cam drive chain sprocket and crankcase when the crankshaft is rotated.

NOTE:

There is a holder for the bottom end of the cam chain guide cast in the crankcase. Be sure that the guide ② is inserted properly or binding of the cam chain and guide may result.

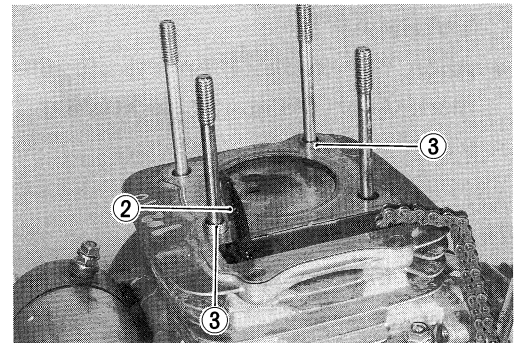
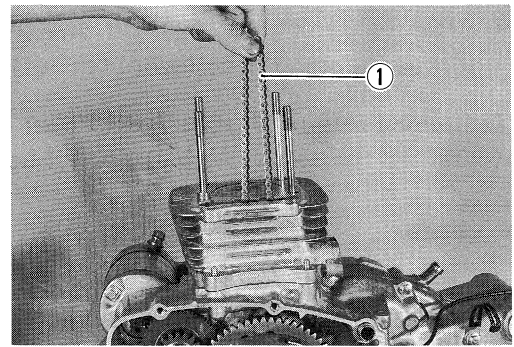
**CYLINDER HEAD**

- Fit dowel pins ③ to the cylinder and then, attach a new gasket to the cylinder.

CAUTION:

Use a new cylinder head gasket to prevent oil leakage. Do not use the old gasket.

- Copper washers and cap nuts are used to secure the cylinder head. These parts must be fitted in the correct position.

- ④ Copper washer
- ⑤ Steel washer

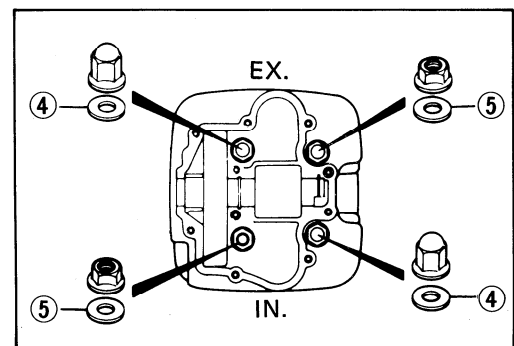

- With the head snugly seated on the cylinder, secure it by tightening the nuts diagonally.
Tighten each nut to the specified torque.

Tightening torque: 21 – 25 N·m
(2.1 – 2.5 kg·m, 15.0 – 18.0 lb·ft)

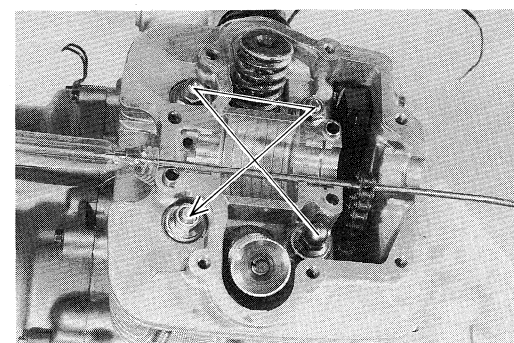

- After tightening the cylinder head nuts ① to the specified torque, tighten the cylinder base nuts ②.

**Tightening torque ①, ②: 7 – 11 N·m
(0.7 – 1.1 kg-m, 5.0 – 8.0 lb-ft)**

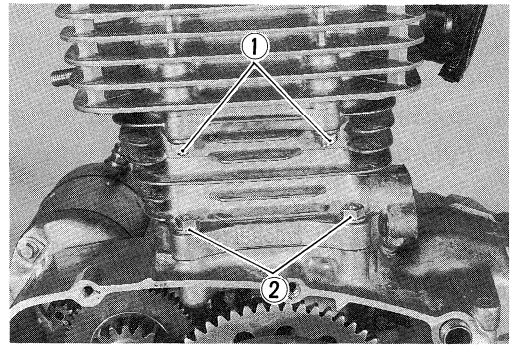

CAMSHAFT

- Align "T" mark ③ on the magneto rotor with the index mark ④ on the crankcase keeping the camshaft drive chain pulled upward.

NOTE:

If work is done without drawing the camshaft drive chain upward, the chain will be caught between crankcase and cam chain drive sprocket.

NOTE:

Apply grease on the cam sprocket locating pin and install the pin into the camshaft.

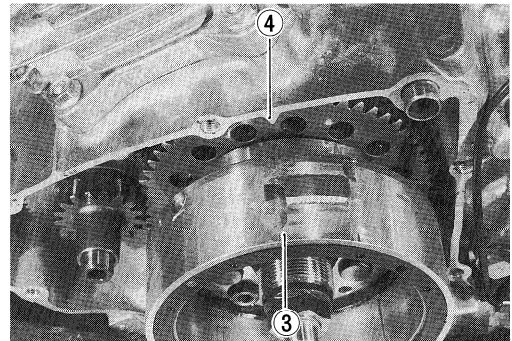

- Engage the chain on the cam sprocket with the locating pin hole ⑤ at just past top position.

NOTE:

Do not rotate magneto rotor while doing this. When the sprocket is not positioned correctly, turn the sprocket. When installing the camshaft into the cam sprocket, pay attention not to dislodge the locating pin or it may fall into the crankcase.

- Align the marks ⑥ on the camshaft so that it is parallel with the surface of the cylinder head.
- Fit lock washer so that it is covering the locating pin.
- Apply THREAD LOCK SUPER "1303" to the bolts and tighten them.

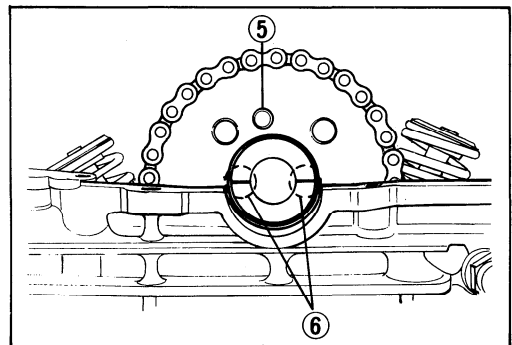

99000-32030: Thread Lock Super "1303"

**Tightening torque: 10 – 12 N·m
(1.0 – 1.2 kg-m, 7.0 – 8.5 lb-ft)**

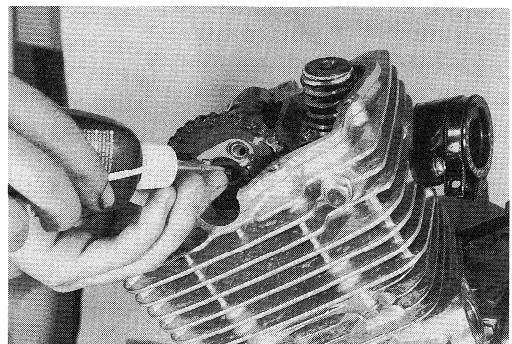

- Bend up the washer tongues positively to lock the bolts.

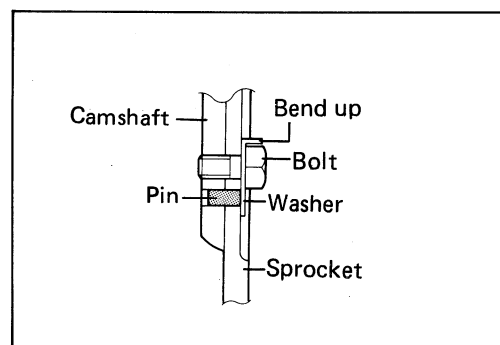

- Apply SUZUKI MOLY PASTE to the camshaft journals.

99000-25140: SUZUKI Moly paste

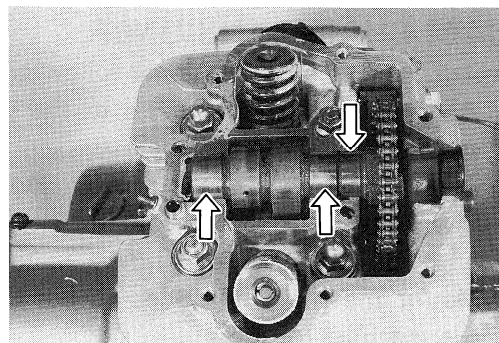

CYLINDER HEAD COVER

- Fit the two dowel pins ① to the cylinder head side.

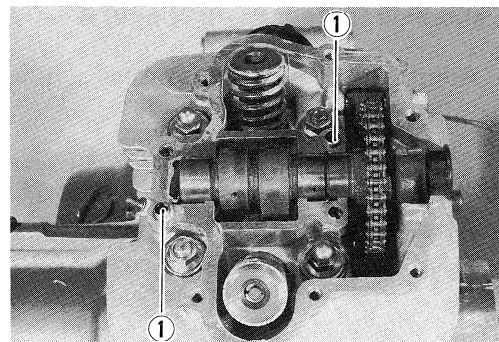

- Uniformly apply SUZUKI BOND No. 1207B/1215 to the cylinder head cover surface.

99104-31140: SUZUKI Bond No. 1207B (U.S.A.)

99000-31110: SUZUKI Bond No. 1215 (Others)

NOTE:

Do not apply SUZUKI BOND No. 1207B/1215 to the camshaft end cap.

- Fit a new gasket ② to each head cover bolt as shown in the illustration.

CAUTION:

Do not use the old gaskets to prevent oil leakage.

NOTE:

When tightening the cylinder head cover bolts, piston position must be at top dead center on compression stroke.

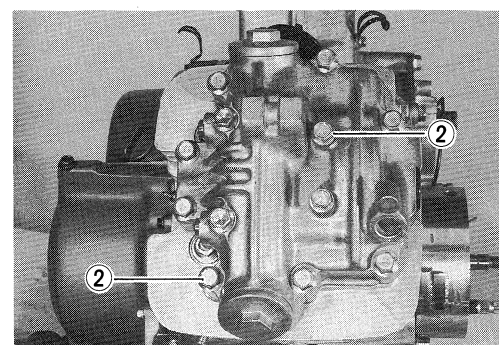
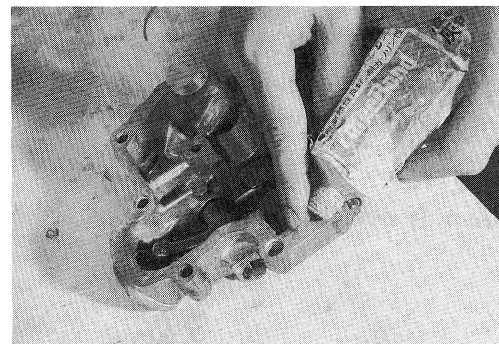

3-49 ENGINE

- Lightly tighten the cylinder head cover bolts diagonally, and then if everything is satisfactory, tighten securely with a torque wrench to the specific torque in the order indicated in photo.

Tightening torque: 9 – 11 N·m (0.9 – 1.1 kg-m, 6.5 – 8.0 lb-ft)

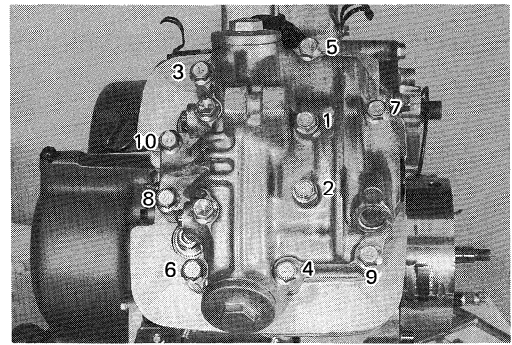

CAM CHAIN TENSIONER

Install the cam chain tensioner following the procedure below.

- Apply SUZUKI Moly paste to the push rod and slide the spring on the push rod.
- After loosening the lock nut ①, loosen screw ② and fully insert the push rod ③ into the chain tensioner. Lock the push rod ③ by tightening the adjusting screw ②.
- Mount the chain tensioner on the cylinder and tighten to the specified torque.

Tightening torque: 6 – 8 N·m (0,6 – 0,8 kg-m, 4,5 – 6,0 lb-ft)

- Adjust the cam chain tensioner. (Refer to page 2-5.)

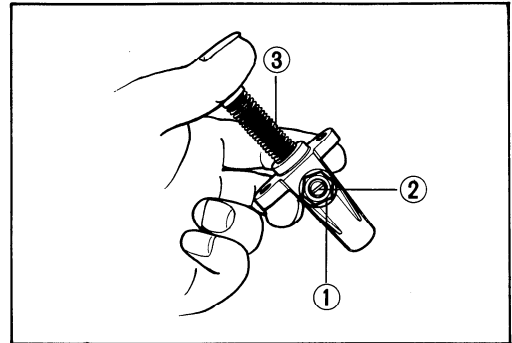

VALVE CLEARANCE

- After tightening the head cover bolts, check and adjust the valve clearance. (Refer to page 2-4.)

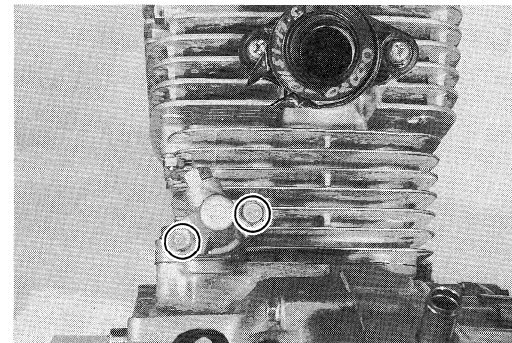

MAGNETO COVER

- Fit the dowel pins and new gasket.
- Install the magneto cover.

CAUTION:

Use only new gasket to prevent oil leakage.

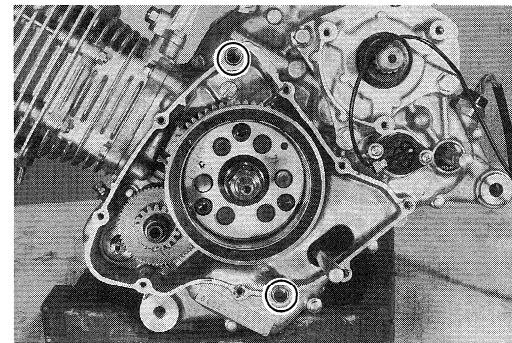

FUEL AND LUBRICATION SYSTEM

CONTENTS

FUEL COCK	4-1
CARBURETOR	4-2
SLOW SYSTEM	4-3
MAIN SYSTEM	4-3
STARTER SYSTEM WITH LIMITER	4-4
FLOAT SYSTEM	4-4
REMOVAL AND DISASSEMBLY	4-5
INSPECTION	4-6
NEEDLE VALVE	4-6
FLOAT HEIGHT ADJUSTMENT	4-6
REASSEMBLY AND REMOUNTING	4-6
LUBRICATION SYSTEM	4-7
OIL PRESSURE	4-7
LUBRICATION CHART	4-8

FUEL COCK

REMOVAL

- Turn fuel cock lever to "OFF" position and disconnect fuel hoses from the fuel cock.
- Place a clean oil pan under the fuel cock assembly, turn fuel cock lever to "ON" position and drain the fuel.
- Remove the fuel cock assembly.

WARNING:

Gasoline is very explosive.
Extreme care must be taken.

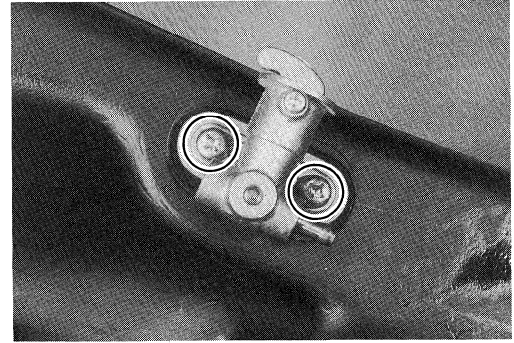

CLEANING

Dust from the fuel tank tends to build up in the filter, which, when the filter has been neglected for a long period, inhibits the flow of fuel.

Remove the dust from the filter using compressed air.

WARNING:

Gasket must be replaced with a new one to prevent leakage.

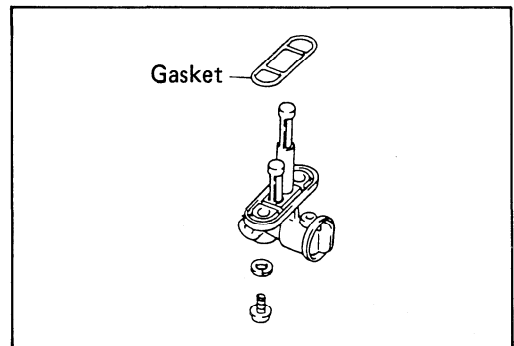
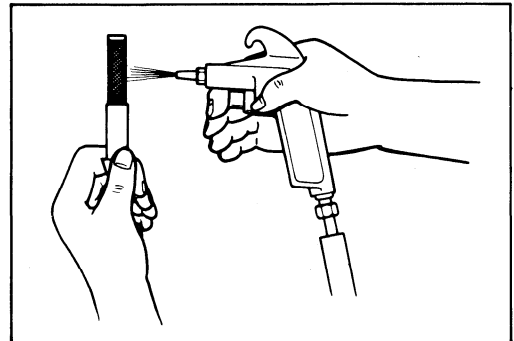

CARBURETOR

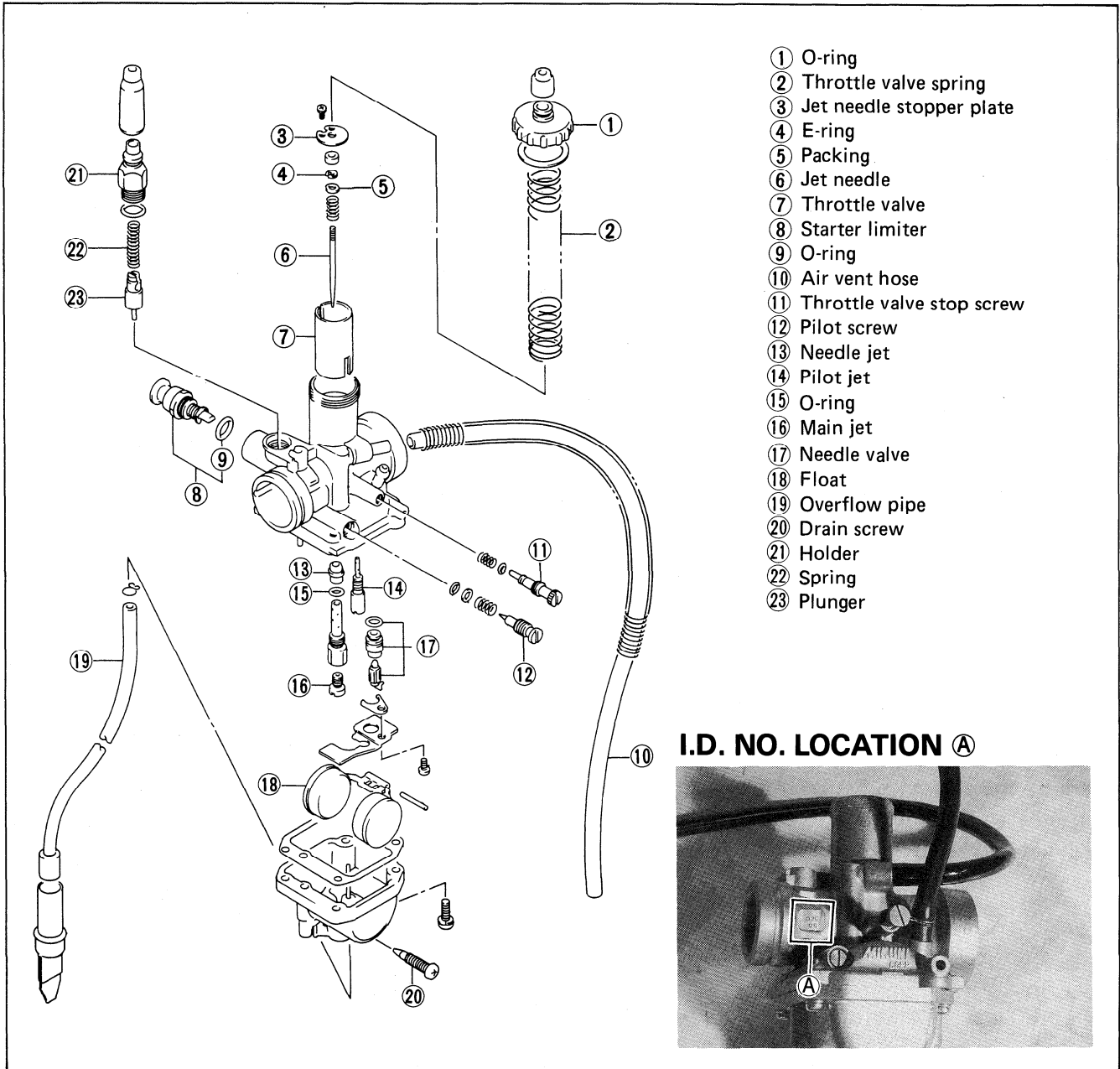

ITEM	SPECIFICATION		ITEM	SPECIFICATION	
Carburetor type	MIKUNI VM20SS		Pilot jet	# 17.5	# 20
Bore size	20 mm		By-pass	1.2 mm	
I.D. No.	02C00	02C01	Pilot outlet	0.7 mm	
Idle r/min.	1 500 ± 50 r/min.		Valve seat	1.5 mm	
Float height	25.8 ± 1.0 mm (1.02 ± 0.04 in)		Starter jet	# 22.5	
Main jet	# 82.5	# 90	Pilot screw	2.0 turns back	
Main air jet	1.0 mm		Pilot air jet	1.3 mm	
Jet needle	5FU96-3rd		Throttle cable play	0.5 – 1.0 mm (0.02 – 0.04 in)	
Needle jet	O-1		Choke cable play	0.5 – 1.0 mm (0.02 – 0.04 in)	
Cut-away	2.5				

SLOW SYSTEM

This system supplies fuel during engine operation with piston valve closed or slightly opened. The fuel metered by the pilot jet is mixed with the proper amount of air metered by the pilot air jet and is separated into fine particles. Mixture then exits into the main bore through the pilot outlet. The pilot screw controls the amount of mixture. When the piston valve opens a little, the mixture jets through the by-pass and the pilot outlet.

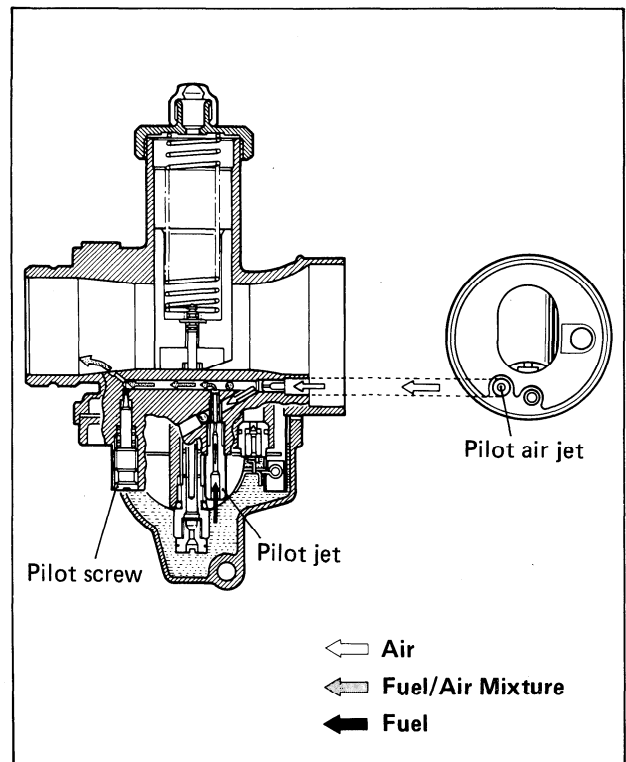

MAIN SYSTEM

This system supplies fuel during engine operation when the piston valve is 1/4—Full open. The fuel passes through the main jet and mixes with air metered by the main air jet. The mixture passes by the clearance between the needle jet and jet needle and then exits into the main bore after being metered by the jet needle.

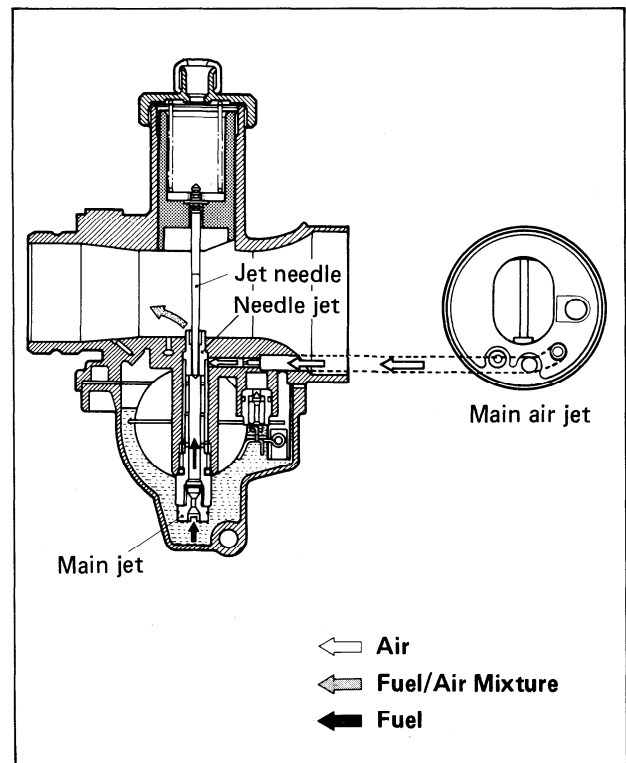

STARTER SYSTEM WITH LIMITER

When the starter valve is pulled up, the fuel metered by the starter jet is mixed with air coming from the float chamber. This mixture, rich with fuel, flows into the starter valve area and mixes again with air coming from the starter air passage.

The two successive mixings of fuel with air are such that a proper fuel/air mixture for starting is produced when the mixture is sprayed out through starter outlet into the main bore.

The starter system features both a summer and winter starter setting for easy starting in all air temperature conditions. The starter circuit is fitted with a "limiter" device that allows the starter plunger to only move to the summer starting position under normal use of the starter. Summer starting temperature conditions are considered to be in the 5°C (40°F) and higher range.

Under winter type air temperature conditions, below 5°C (40°F), the limiter should be pulled out and then the regular starter lever can "open" the starter circuit further providing the richer fuel mixture needed for easy cold weather starts.

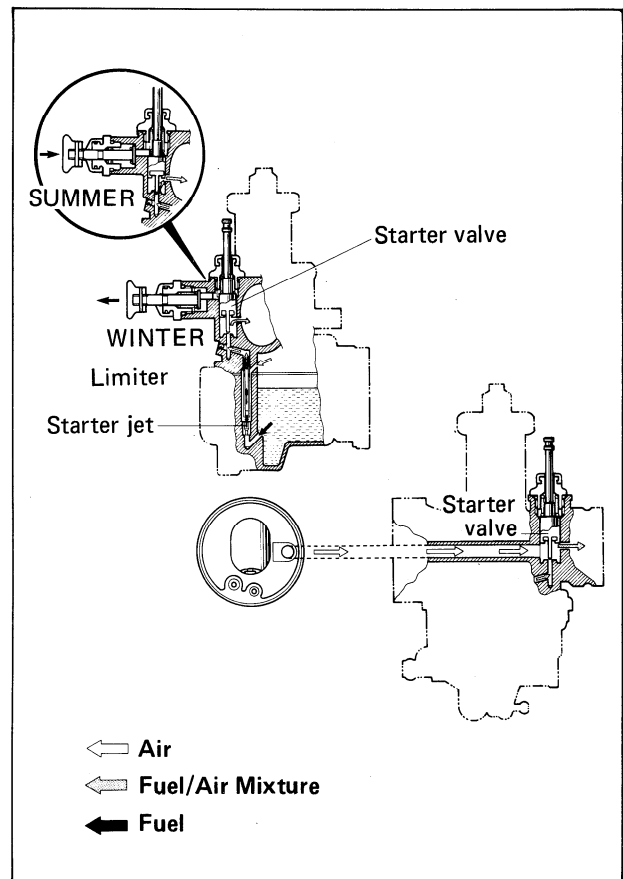

FLOAT SYSTEM

Floats and needle valve are associated with the same mechanism, so that, as the floats move up and down, the needle valve too moves likewise. When fuel level is up in float chamber, floats are up and needle valve remains pushed up against valve seat. Under this condition, no fuel enters the float chamber.

As the fuel level falls, floats go down and needle valve unseats itself to admit fuel into the chamber. In this manner, needle valve admits and shuts off fuel alternately to maintain a practically constant fuel level inside the float chamber.

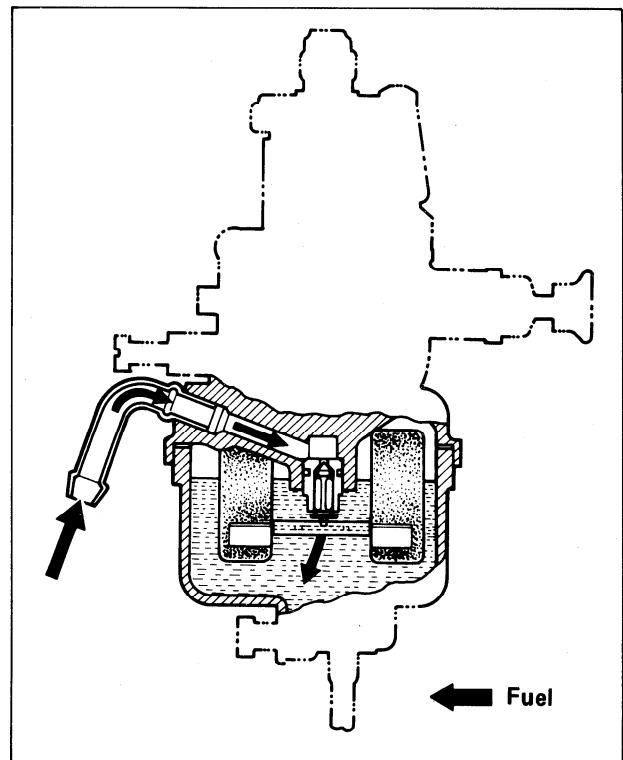

REMOVAL AND DISASSEMBLY

- Remove the seat, front fender and fuel tank. (Refer to page 6-1.)
- Loosen the clamp screws and remove the carburetor. (Refer to page 3-4.)
- Loosen the carburetor top end cap and remove the throttle valve assembly.

WARNING:

Gasoline is very explosive.
Extreme care must be taken.

- Remove the float chamber.

- Remove the float pin and float.

CAUTION:

When removing the float pin, be careful not to damage the carburetor body.

- Remove the main jet, needle jet and pilot jet.
- Remove the plate by removing the screw, then remove the needle valve seat.

NOTE:

Replace a O-ring with a new one when reassembling.

- Remove the starter limiter.

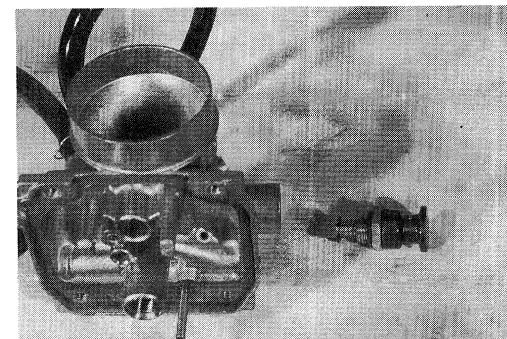
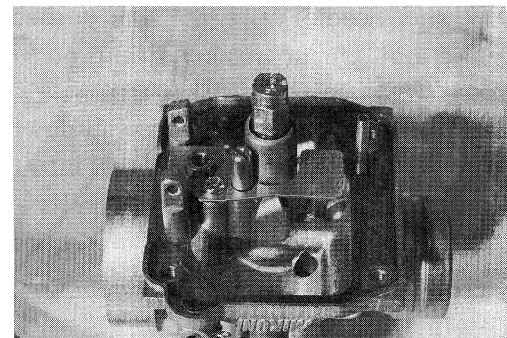
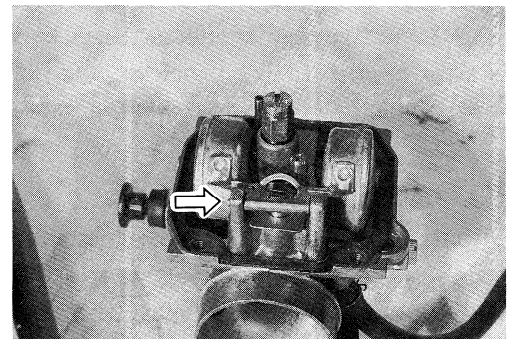
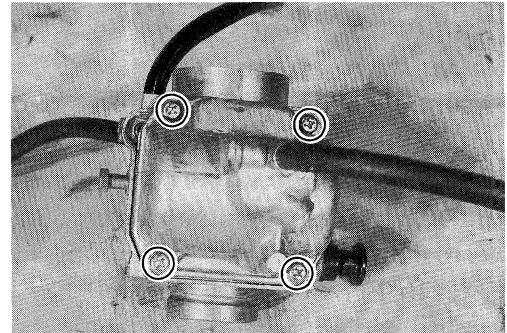
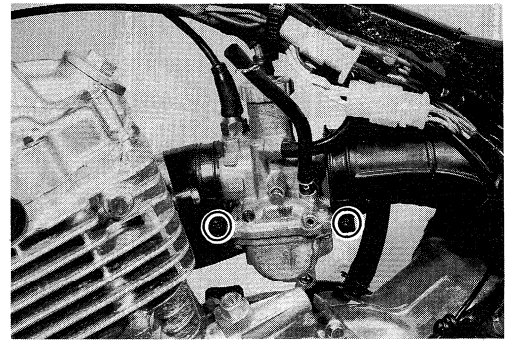

INSPECTION

Check the following items for any damage or clogging.

- * Pilot jet
- * Main jet
- * Needle jet air bleeding hole
- * Float
- * Needle valve mesh
- * Gasket
- * Throttle valve
- * Pilot outlet and bypass holes

NEEDLE VALVE

If foreign matter is caught between the valve seat and the needle, the gasoline will continue flowing and cause it to overflow. If the seat and needle are worn beyond the permissible limits, similar trouble will occur. Conversely, if the needle sticks, the gasoline will not flow into the float chamber. Clean the float chamber and float parts with gasoline. If the needle is worn as shown in the illustration, replace it together with a valve seat. Clean the fuel passage of the mixing chamber with compressed air.

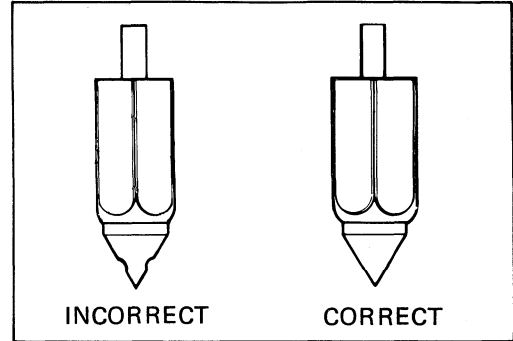

FLOAT HEIGHT ADJUSTMENT

To check the float height, invert the carburetor body, holding the float arm pin so that the pin will not slip off. With the float arm kept free, measure the height $\text{\textcircled{A}}$ while float arm is just in contact with needle valve by using calipers.

Bend the tongue $\text{\textcircled{1}}$ as necessary to bring the height $\text{\textcircled{A}}$ to this value.

Float height $\text{\textcircled{A}}$:

09900-20101: Vernier calipers

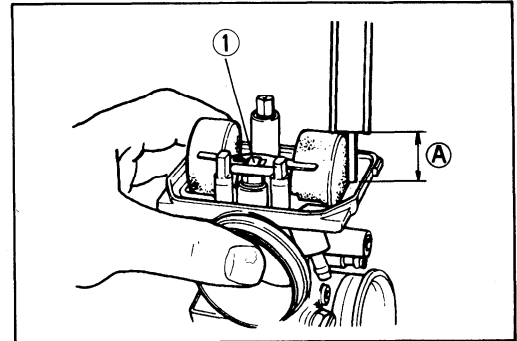

REASSEMBLY AND REMOUNTING

Reassemble and remount the carburetor in the reverse order of removal and disassembly, and following adjustments are necessary after remounting the carburetor.

Throttle cable play (Refer to page 2-6.)

Idling adjustment (Refer to page 2-6.)

LUBRICATION SYSTEM

OIL PRESSURE

- Remove the bolt ①.
- Install the oil pressure gauge adaptor ② and gauge set ③.

09915-74510: Oil pressure gauge set

09915-74531: Adaptor

- Connect an electric tachometer to the high tension cord of ignition coil.

09900-26005: Engine tachometer (Not available in U.S.A.)

- Warm up the engine as follows.
Summer approx. 10 min. at 2 000 r/min.
Winter approx. 20 min. at 2 000 r/min.
- After the warming up operation, increase the engine speed to 3 000 r/min, and read the oil pressure gauge.

NOTE:

Engine oil must be warmed up to 60°C (140°F) when checking the oil pressure.

Oil pressure specification

Above: 30 kPa (0.30 kg/cm², 4.3 psi)

Below: 70 kPa (0.70 kg/cm², 10.0 psi) at 3 000 r/min.

Oil temp. at 60°C (140°F)

If the oil pressure is lower or higher than the specifications, several causes may be considered.

- * Low oil pressure is usually the result of a oil leakage from the oil passageway, damaged oil seal, a defective oil pump or a combination of these items.
- * High oil pressure is usually caused by a engine oil which is too heavy a weight, a clogged oil passage or filter, improper installation of the oil filter or a combination of these items.

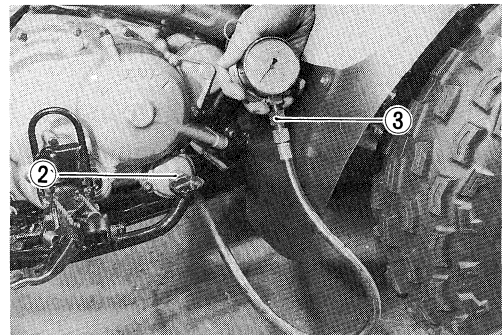
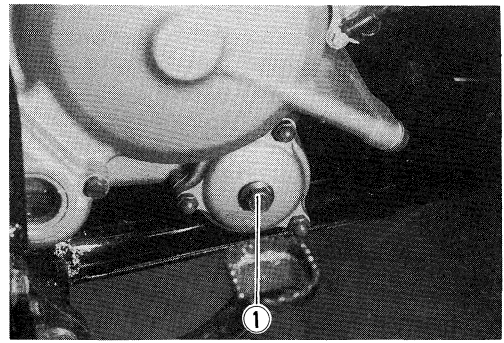

LUBRICATION SYSTEM CHART

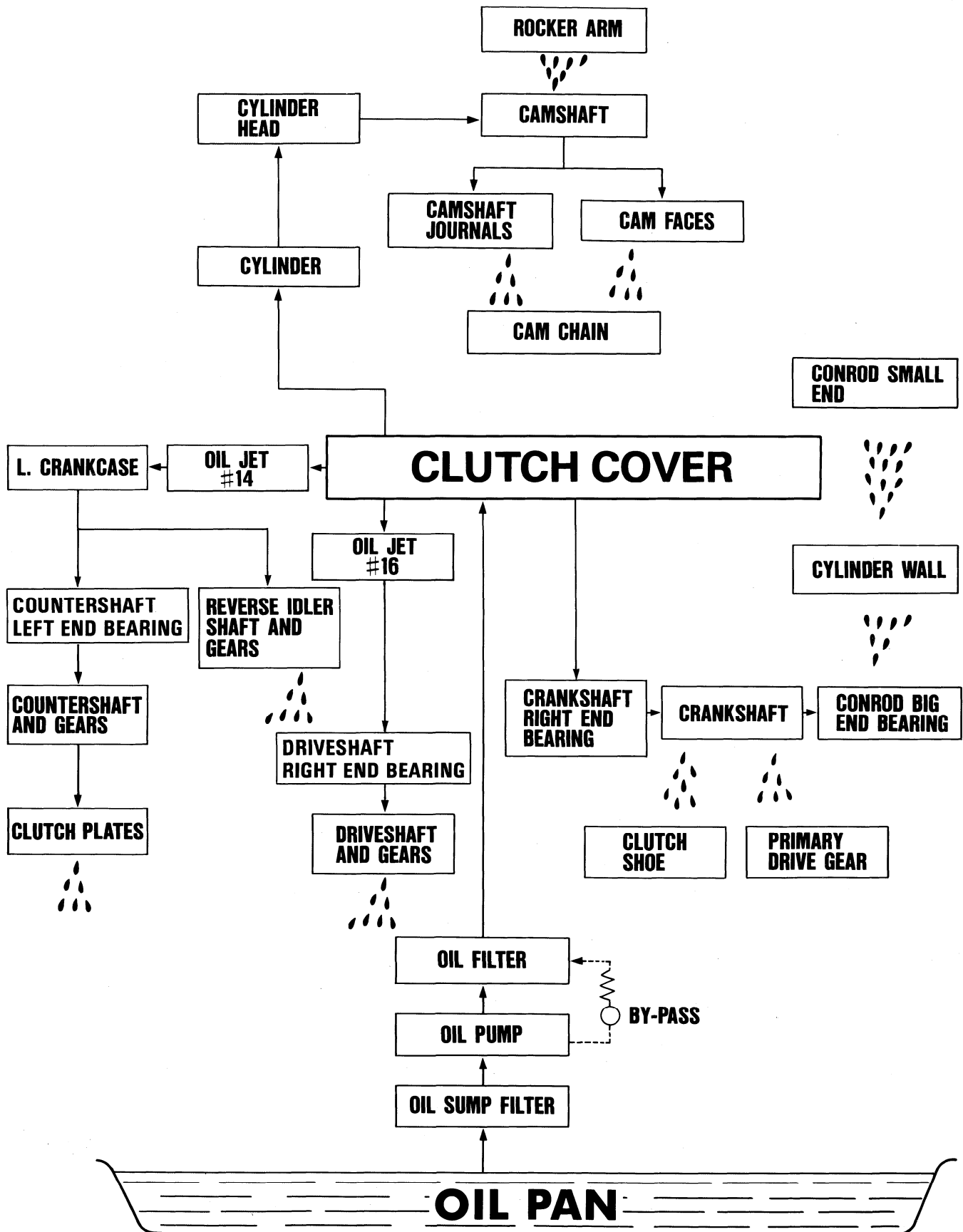

ELECTRICAL SYSTEM

CONTENTS

IGNITION SYSTEM	5- 1
DESCRIPTION	5- 1
INSPECTION	5- 1
CHARGING SYSTEM	5- 3
DESCRIPTION	5- 3
INSPECTION	5- 5
STARTER SYSTEM	5- 6
DESCRIPTION	5- 6
STARTER MOTOR	5- 7
STARTER RELAY	5- 9
NEUTRAL RELAY	5-10
LAMPS	5-10
SWITCHES	5-11
BATTERY	5-12

IGNITION SYSTEM

DESCRIPTION

In the capacitor discharged ignition system, the electrical energy generated by the magneto charges the capacitor. This energy is released in a single surge at the specified ignition timing point, and current flows through the primary side of the ignition coil. A high voltage current is induced in the secondary windings of the ignition coil resulting in strong spark between the spark plug gaps.

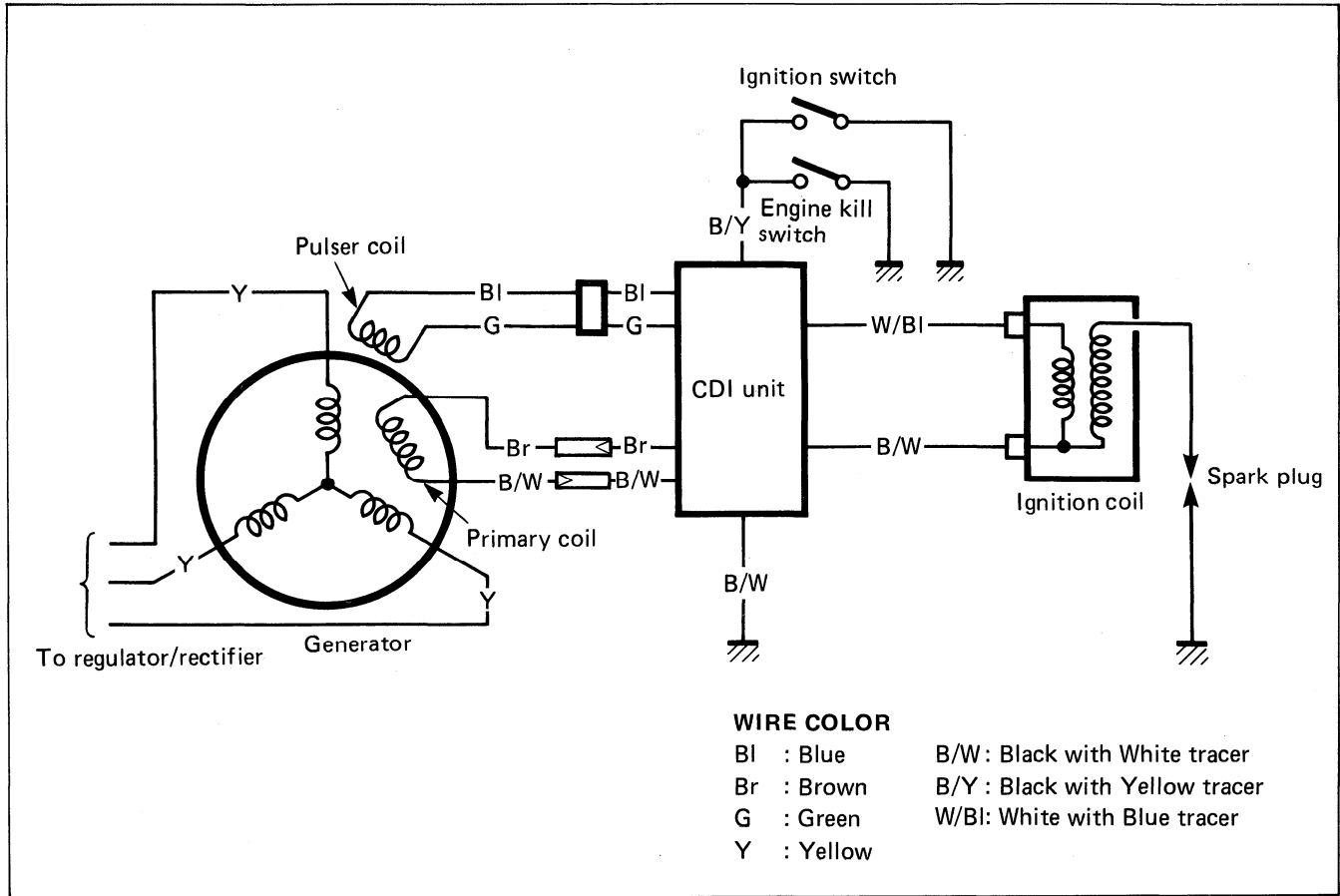

INSPECTION

MAGNETO COIL

- Remove the rear fender. (Refer to page 6-3.)
- Disconnect the pick-up and power source lead wires.
- Using the pocket tester, measure the resistance between the lead wires in the following table.

09900-25002: Pocket tester

Magneto coil resistance

Pulser coil (BI – G) : 200 – 400 Ω

Primary coil (Br – B/W): 350 – 550 Ω

NOTE:

When replacing the stator, apply a small quantity of **THREAD LOCK "1342"** to the threaded parts of stator screws.

99000-32050: Thread Lock "1342"

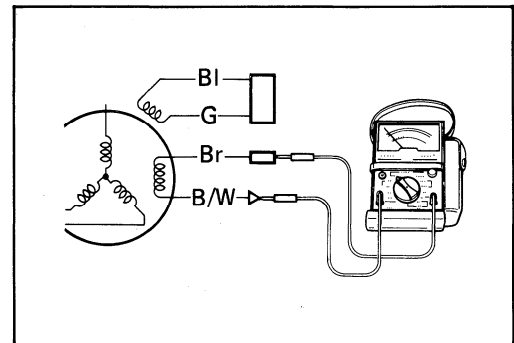

IGNITION COIL (Checking with Electro Tester)

- Remove the front fender. (Refer to page 6-1.)
- Remove the ignition coil from the frame.
- Using the electro tester, test the ignition coil for sparking performance. The test connection is as indicated. Make sure that the three-needle sparking distance is at least 8 mm. If no sparking or orange color sparking occurs with this much gap, then it is defective and must be replaced.

STD Spark performance: 8 mm (0.3 in)

09900-28106: Electro tester

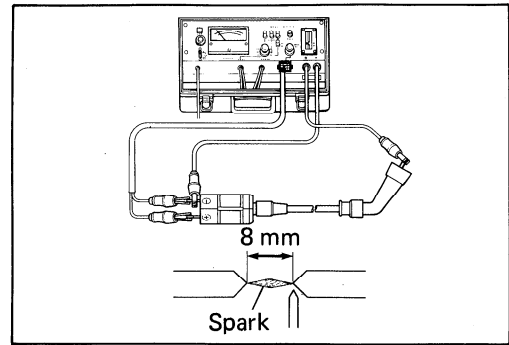

IGNITION COIL (Checking with Pocket Tester)

- A SUZUKI Pocket tester or an ohm meter may be used, instead of the electro tester. In either case, the ignition coil is to be checked for continuity in both primary and secondary windings. Exact ohmic readings are not necessary, but, if the windings are in sound condition, their continuity will be noted with these approximate ohmic values.

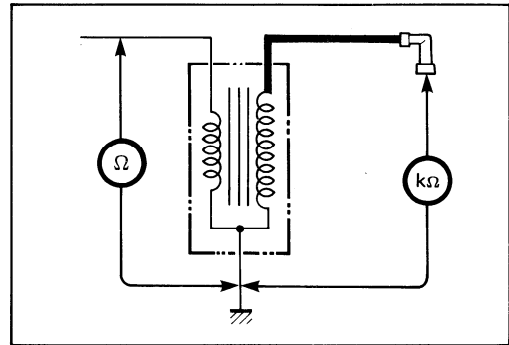

Ignition coil resistance

Primary (Terminal – Ground): 0.1 – 1.0 Ω

Secondary (Plug cap – Ground) : 10 – 25 kΩ

09900-25002: Pocket tester

CDI UNIT (Checking with Pocket Tester)

- Remove the front fender cover. (Refer to page 6-1.)
- Remove the CDI unit from the frame.
- Use the SUZUKI pocket tester, bring the ⊕ probe and the ⊖ probe in to contact with each lead wire of the CDI unit, check for continuity, and measure the resistance value.
- When the continuity and the resistance values are as shown in the following table, it can be judged that the CDI unit is normal.

CAUTION:

As capacitors, diodes, etc. are used inside this CDI unit, the resistance values will differ when an ohmmeter other than SUZUKI pocket tester is used.

Unit: Approx. kΩ

		⊕ Probe of tester to:					
		G	Bl	B/Y	B/W	Br	W/Bl
⊖ Probe of tester to:	G		∞	20 – 40	6 – 16	∞	∞
	Bl	10 – 25		20 – 40	1.5 – 5	∞	∞
	B/Y	∞	∞		∞	∞	∞
	B/W	6 – 15	∞	6 – 16		∞	∞
	Br	30 – 100	80 – 250	100 – 500	25 – 50		∞
	W/Bl	10 – 25	∞	20 – 40	1.5 – 5	∞	

CHARGING SYSTEM

DESCRIPTION

The circuit of the charging system is indicated in the figure, which is composed of an AC generator, regulator/rectifier unit and battery.

The AC current generated from the AC generator is rectified by the rectifier and is turned into DC current, then it charges the battery.

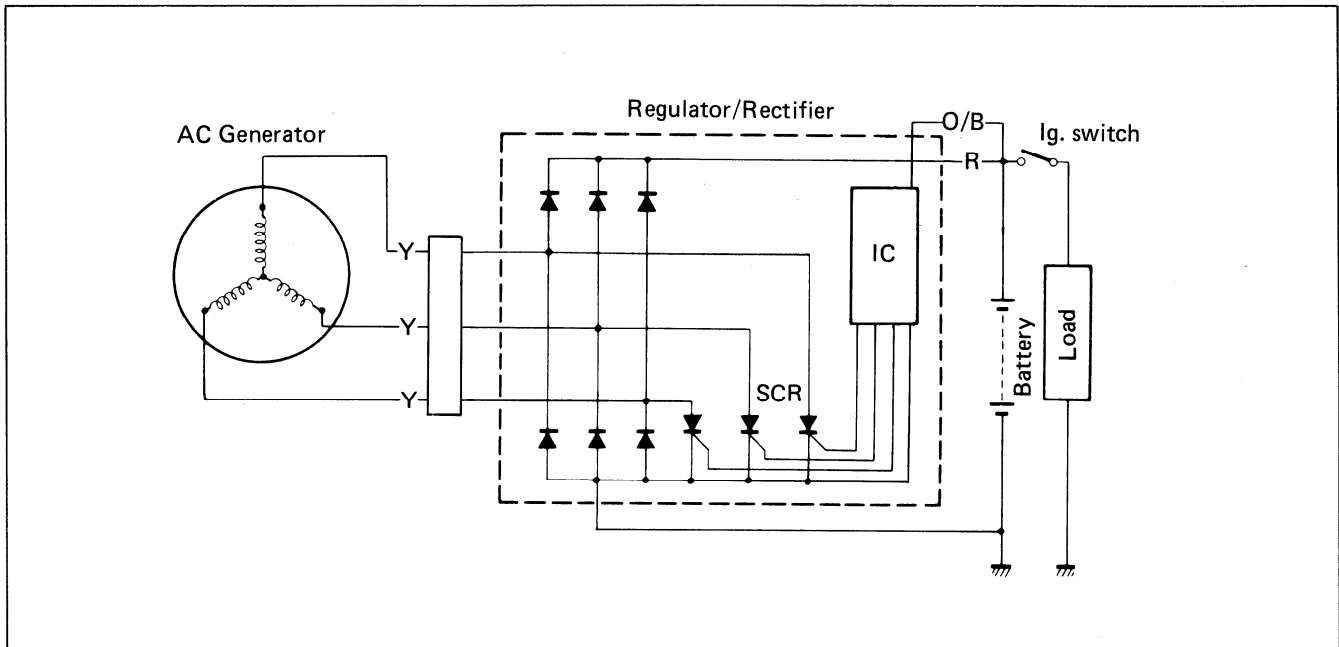

Function of Regulator

While the engine r/min is low and the generated voltage of the AC generator is lower than the adjusted voltage of regulator, the regulator does not function. However, the generated current charges the battery directly at this time.

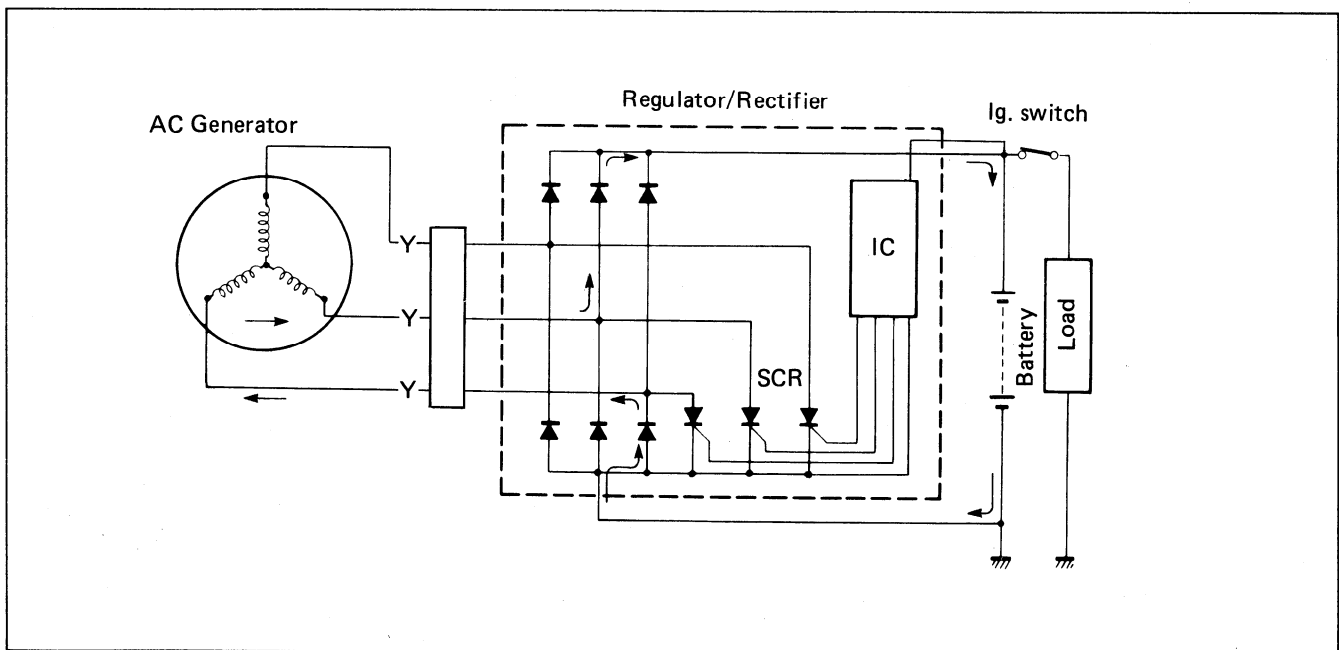

When the engine r/min becomes higher, the generated voltage of the AC generator also becomes higher and the voltage between the battery terminals becomes high accordingly. When it reaches the adjusted voltage of the I.C. (Integrated Circuit) and it is turned "ON," a signal will be sent to the SCR (Thyristor) gate probe and the SCR will be turned "ON."

Then, the SCR becomes conductive in the direction from point (A) to point (B). At this time, the current generated from the AC generator gets through the SCR without charging the battery and returns to AC generator again. At the end of this state, since the AC current generated from AC generator flows to point (B), the reverse current tends to flow to SCR. Then, the circuit of SCR turns to the OFF mode and begins to charge the battery again. Thus these repetitions maintain charging voltage and current to the battery constant and protect it from overcharging.

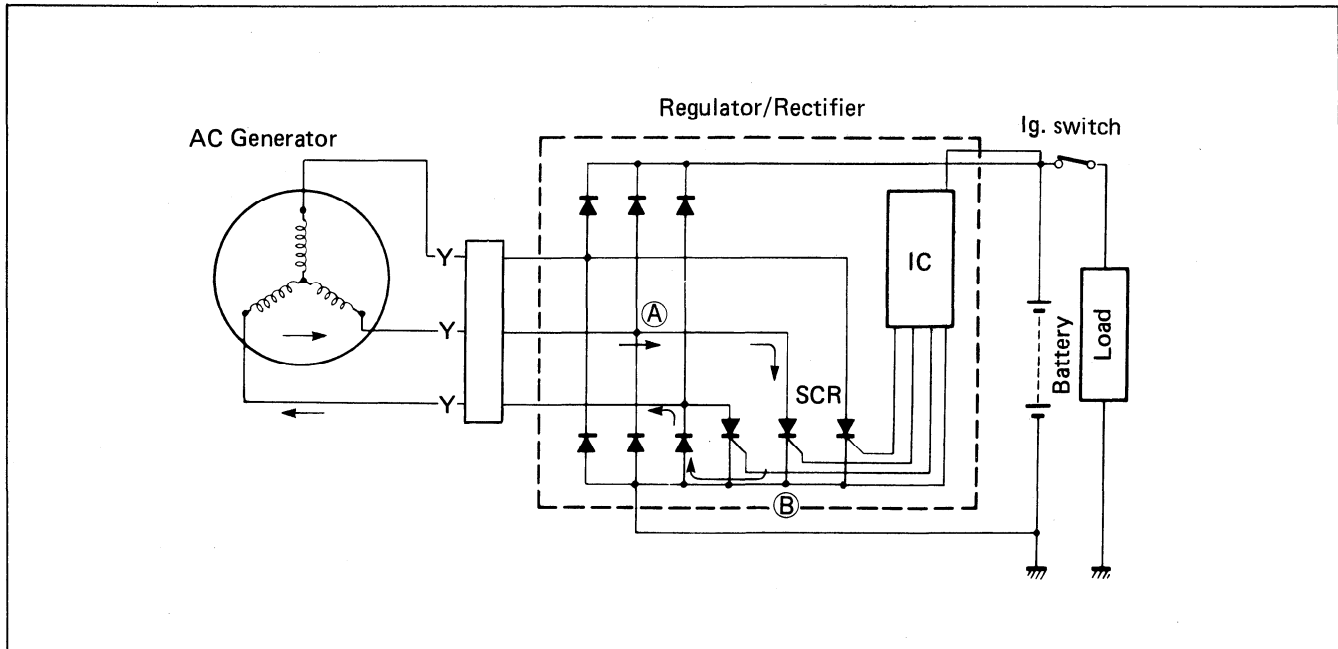

INSPECTION

CHARGING OUTPUT CHECK

- Remove the front fender cover. (Refer to page 6-1.)
 - Connect an electric tachometer to the high tension cord.
 - Ignition switch turned "LIGHT" position.
 - Start the engine and keep it running at 5 000 r/min.
 - Using the pocket tester, measure the DC voltage between the battery terminal ⊕ and ⊖.
- If the tester reads under 13.5V or over 15.5V, check the AC generator no-load performance and regulator/rectifier.

Regulated voltage: 13.5 – 15.5V (DC) at 5 000 r/min

09900-25002: Pocket tester

NOTE:

When making this test, be sure that the battery is fully charged condition.

AC GENERATOR NO-LOAD PERFORMANCE

- Remove the rear fender. (Refer to page 6-3.)
 - Disconnect the AC generator lead wire.
 - Start the engine and keep it running at 5 000 r/min.
 - Using the pocket tester, measure the AC voltage between the three yellow lead wires.
- If the tester reads under 55V, the AC generator is faulty.

STD No-load performance: More than 55V (AC) at 5 000 r/min

09900-25002: Pocket tester

AC GENERATOR CONTINUITY CHECK

- Using the pocket tester, check the continuity between the lead wires of the stator.
- Also check that the stator core is insulated.

09900-25002: Pocket tester

NOTE:

When making this test, it is not necessary to remove the AC generator.

REGULATOR/RECTIFIER

- Remove the front fender. (Refer to page 6-1.)
 - Using the pocket tester (x 1kΩ range), measure the resistance between the lead wires in the following table.
- If the resistance checked is incorrect, replace the regulator/rectifier.

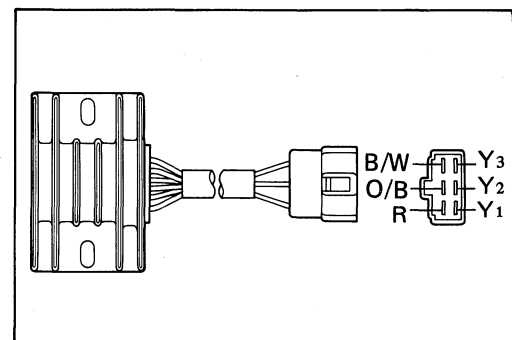
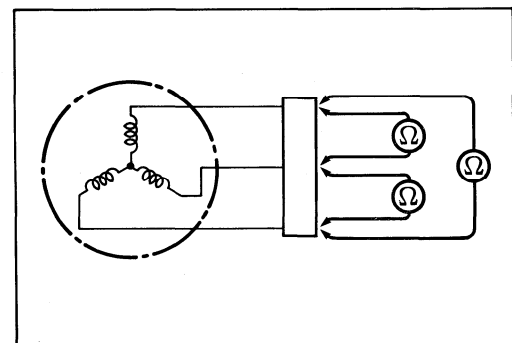
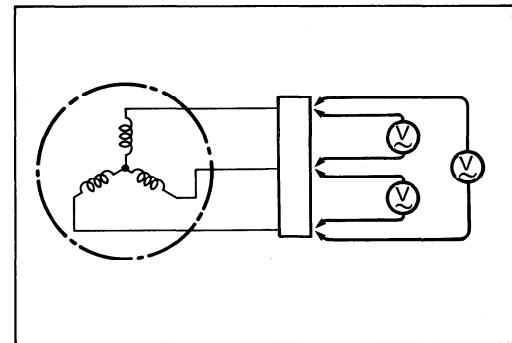
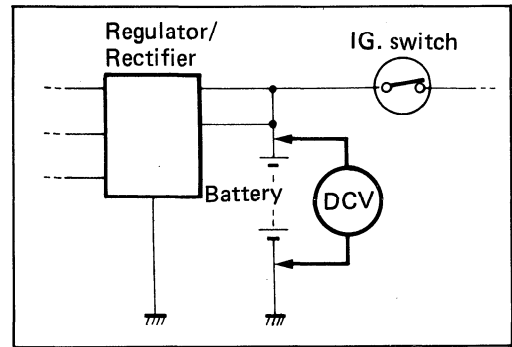

Unit Approx. k Ω

		⊕ Probe of tester to:					
		R	O/B	B/W	Y ₁	Y ₂	Y ₃
⊖ Probe of tester to:	R		∞	∞	∞	∞	∞
	O/B	5 – 10		0.1 – 1.5	1 – 4	1 – 4	1 – 4
	B/W	4 – 9	0.1 – 1.5		1 – 4	1 – 4	1 – 4
	Y ₁	1 – 4	∞	∞		∞	∞
	Y ₂	1 – 4	∞	∞	∞		∞
	Y ₃	1 – 4	∞	∞	∞	∞	

09900-25002: Pocket tester

CAUTION:

As transistors, capacitors, zener diodes, etc. are used inside this regulator/rectifier, the resistance values will differ when an ohmmeter other than the SUZUKI pocket tester is used.

STARTER SYSTEM**DESCRIPTION**

The starter system is shown in the diagram below: namely, the starter motor, starter relay, neutral relay, reverse switch, neutral switch, starter button, engine kill switch, ignition switch and battery. Depressing the starter button (on the left handlebar switch box) energizes the relay, causing the contact points to close which connects the starter motor to the battery. The motor draws about 80 amperes to start the engine.

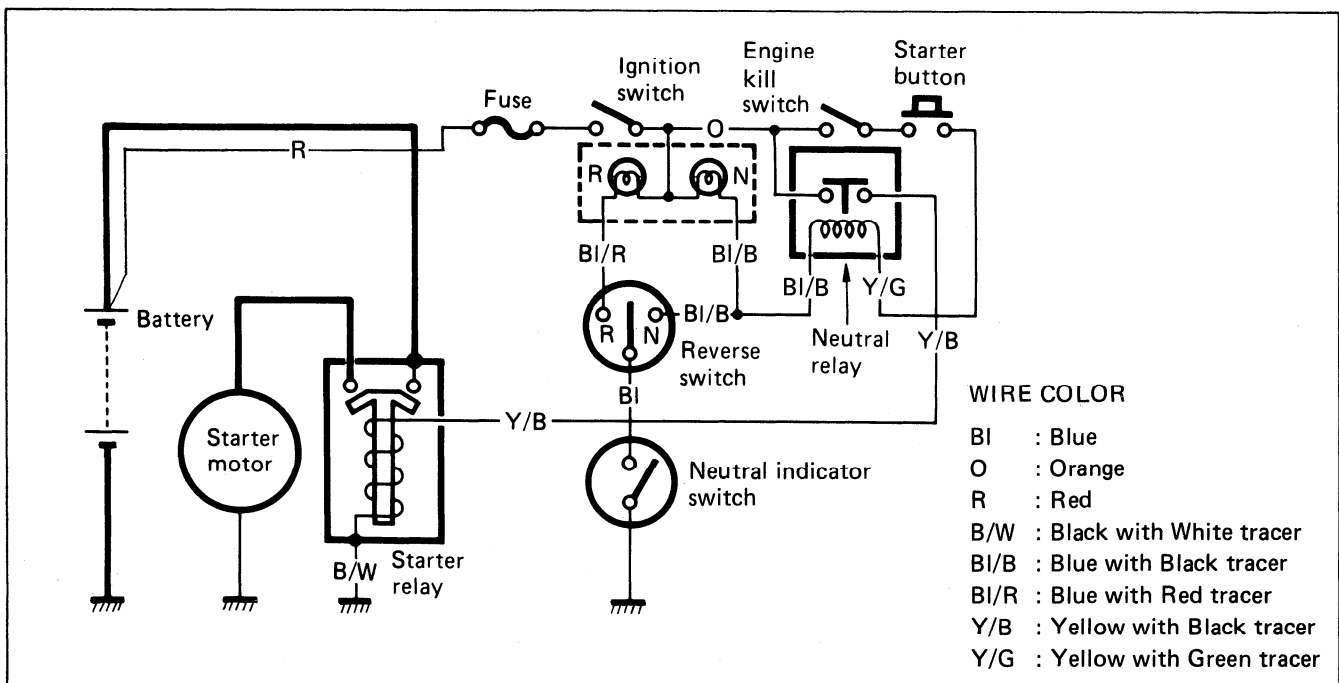

STARTER MOTOR

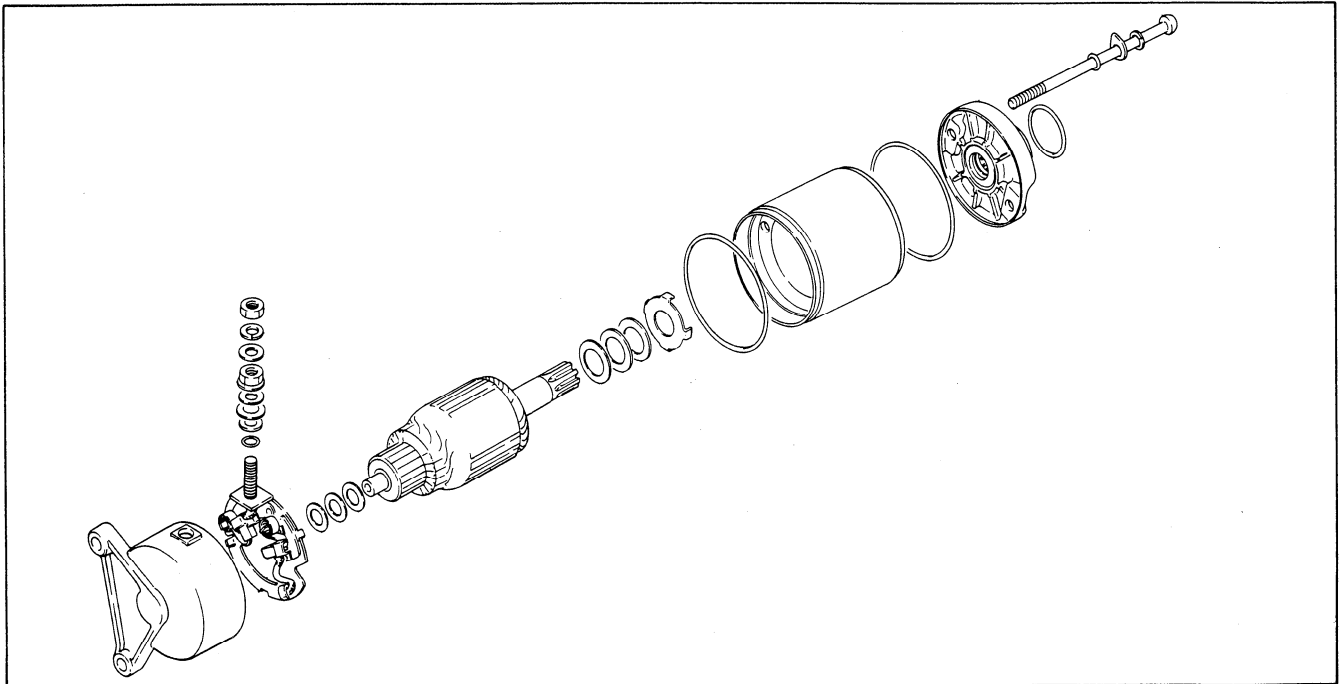

STARTER MOTOR REMOVAL AND DISASSEMBLY

- Disconnect the starter motor lead wire and remove the starter motor.
- Remove the bolts and disassemble the starter motor.

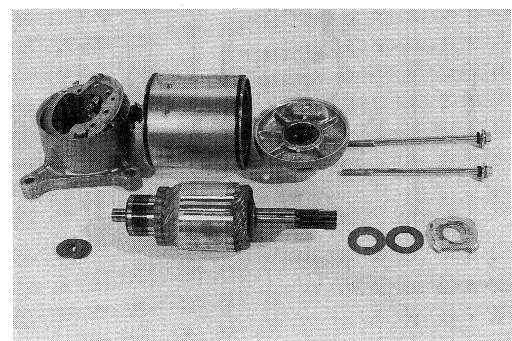
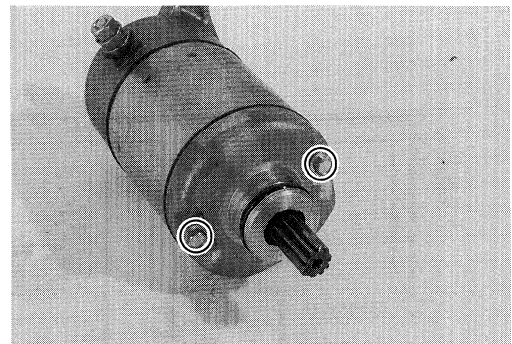
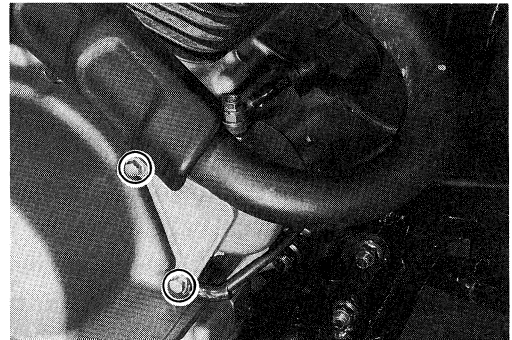

STARTER MOTOR INSPECTION

CARBON BRUSHES

When the brushes are worn, the motor will be unable to produce sufficient torque, and the engine will be difficult to turn over. To prevent this, periodically, inspect the length of the brushes, replacing them when they are too short or chipping.

Service Limit: 9 mm (0.35 in)

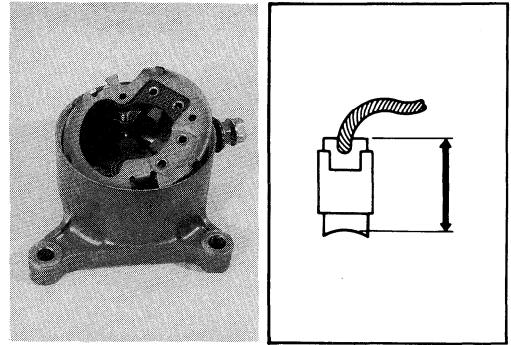

COMMUTATOR

If the commutator surface is dirty, starting performance decreases. Polish the commutator with # 400 or similar fine emery paper when it is dirty. After polishing it, wipe the commutator with a clean dry cloth.

Measure the commutator under-cut ①.

Service Limit: 0.2 mm (0.008 in)

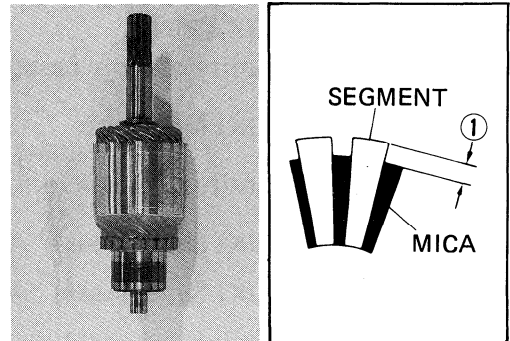

ARMATURE COIL

Using a pocket tester, check the coil for open and ground by placing probe pins on each commutator segment and rotor core (to test for ground) and on any two segments at various places (to test for open), with the brushes lifted off the commutator surface.

If the coil is found to be open circuited or grounded, replace the armature. Continuous use of a defective armature will cause the starter motor to suddenly fail.

09900-25002: Pocket tester

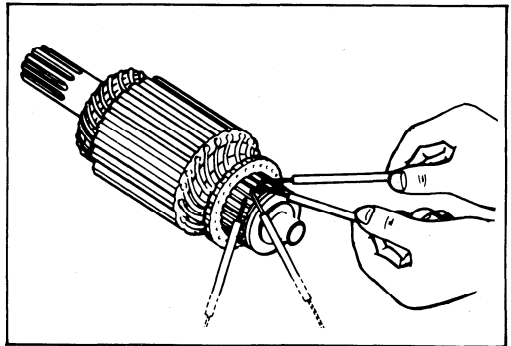
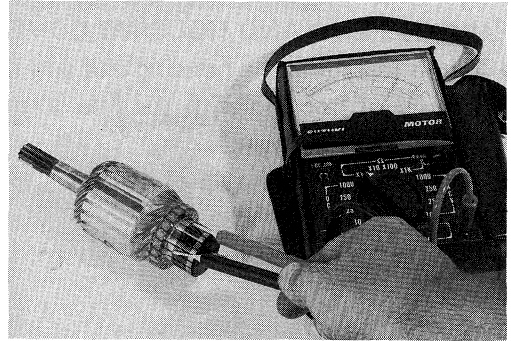

OIL SEAL

Check the seal lip for damage or oil leakage. If any damage is found, replace it with the housing cover.

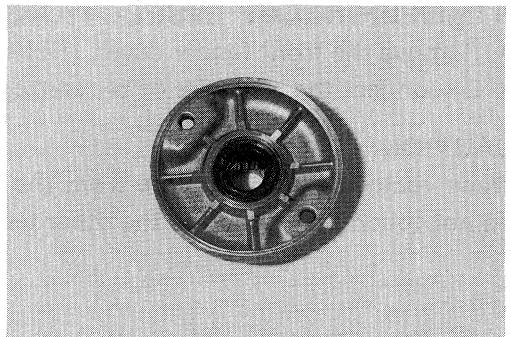

STARTER MOTOR REASSEMBLY

O-RING

- Install new O-rings on the correct positions as shown in Fig.

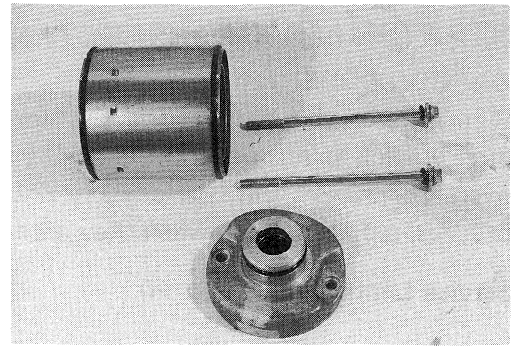

ARMATURE AND BEARING

- Apply a small quantity of moly paste to the armature end.

99000-25140: SUZUKI Moly paste

- Apply a small quantity of grease to the armature bearing.

99000-25030: SUZUKI Super grease "A" (U.S.A.)

99000-25010: SUZUKI Super grease "A" (Others)

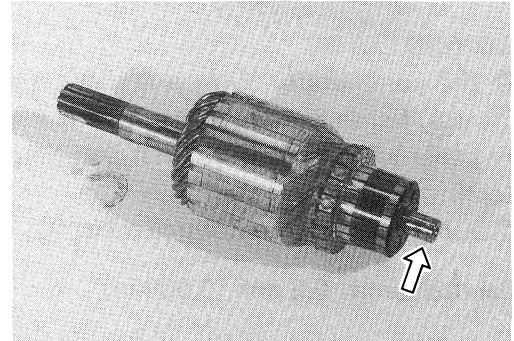

HOUSING END AND HOUSING COVER

- When installing the housing end and housing cover, align the line ① of housing with the line ② of housing end and line ③ of housing cover.
- Apply grease to the lip of oil seal.

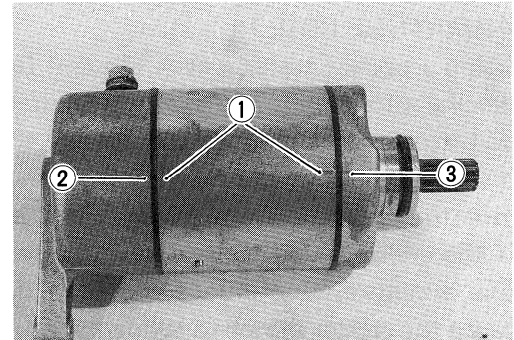

HOUSING SCREW

- Apply a small quantity of THREAD LOCK "1342" to the starter motor housing screws.

99000-32050: Thread Lock "1342"

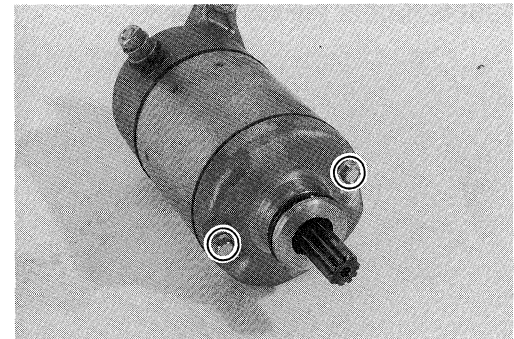

STARTER RELAY INSPECTION

- Remove the front fender cover. (Refer to page 6-1.)
- Disconnect the lead wire of the starter motor at starter relay.

CAUTION:

When removing the lead wire from the starter relay terminal, do not touch the wrench to the other terminal.

- Turn on the ignition switch, inspect the continuity between the terminals, positive and negative, when pushing the starter button.

If the starter relay is in sound condition, continuity is found.

09900-25002: Pocket tester

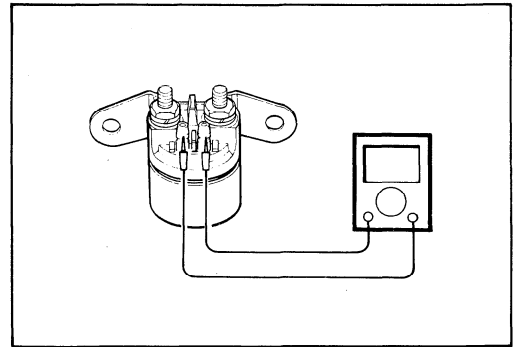

- Disconnect the lead wires from the starter relay.
- Check the coil for "open", "ground" and ohmic resistance. The coil is in good condition if the resistance is as follows.

STD resistance: 3 – 7 Ω

09900-25002: Pocket tester

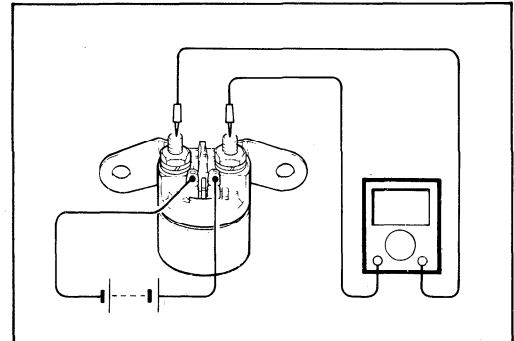

NEUTRAL RELAY INSPECTION

- Remove the front fender cover. (Refer to page 6-1.)
- Remove the neutral relay from the holder.
- Apply 12 volts to ① and ② terminals, + to ① and - to ②, and check the continuity between ③ and ④ with pocket tester. If there is no continuity, replace the neutral relay assembly with a new one.

09900-25002: Pocket tester

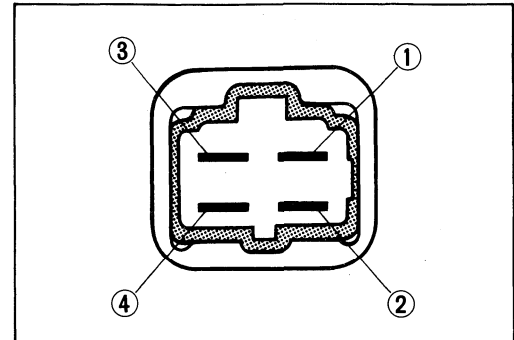

LAMPS

INSPECTION

After installing a new bulb, check for continuity. If the bulb does not light, inspect the wiring for open or short circuit.

Headlight	12V 45/45W
Taillight	12V 5W
Reverse indicator light	12V 3.4W
Neutral indicator light	12V 3.4W

09900-25002: Pocket tester

CAUTION:

Do not overtighten the lens fitting screws.

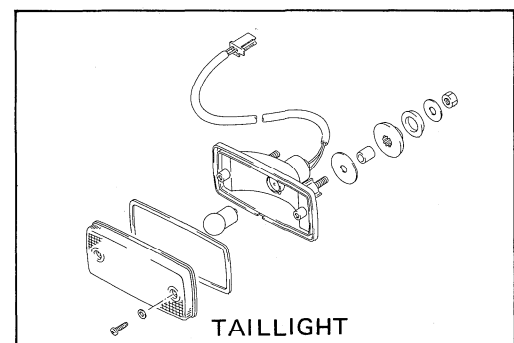
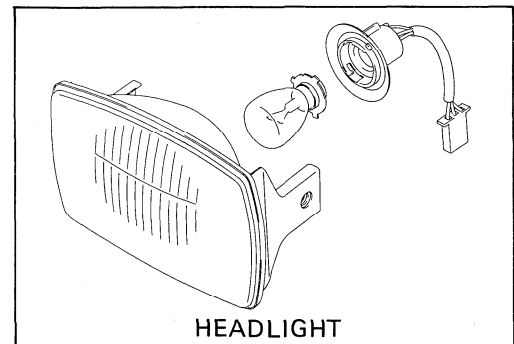

SWITCHES

INSPECTION

Inspect each switch for continuity with the pocket tester referring to the chart. If any abnormality is found, replace the respective switch assemblies with new ones.

09900-25002: Pocket tester

IGNITION SWITCH

COLOR \ POSITION	O	R	Gr	B/W	B/Y
LIGHT	○ — ○ — ○				
ON	○ — ○				
OFF				○ — ○	

REVERSE SWITCH

COLOR \ POSITION	BI/B	BI/R	BI
NEUTRAL	○ — ○ — ○		
REVERSE		○ — ○	

ENGINE KILL AND STARTER BUTTON

COLOR \ POSITION	B/W	B/Y	O	O/W	Y/G
OFF	○ — ○				
RUN			○ — ○		
START (Push)				○ — ○	

DIMMER SWITCH

COLOR \ POSITION	Gr	Y	W
HI	○ — ○		
LO	○ — ○ — ○		

NEUTRAL INDICATOR SWITCH

COLOR \ POSITION	BI	Ground
ON	○ — ○	
OFF		

WIRE COLOR

- BI : Blue
- Gr : Gray
- O : Orange
- R : Red
- W : White
- Y : Yellow
- B/W : Black with White tracer
- B/Y : Black with Yellow tracer
- BI/B : Blue with Black tracer
- BI/R : Blue with Red tracer
- O/W : Orange with White tracer
- Y/G : Yellow with Green tracer

BATTERY

SPECIFICATION

Type designation	YB9A-A
Capacity	12V, 32.4 kC (9 Ah)/10HR
Standard electrolyte S.G.	1.28 at 20°C (68°F)

In fitting the battery to the vehicle, connect the breather pipe to the battery vent.

INITIAL CHARGING

Filling electrolyte

Remove the short sealed tube before filling electrolyte. Fill the battery with electrolyte (dilute sulfuric acid solution with acid concentration of 35.0% by weight, having a specific gravity of 1.28 at 20°C (68°F)) up to indicated UPPER LEVEL. Electrolyte should be always cooled below 30°C (86°F) before filling into battery. Leave the battery standing for half an hour after filling. Add additional electrolyte if necessary.

Charge the battery with current as described in the tables shown below.

Maximum charging current: 0.9A

Charging time

The charging time for a new battery is determined by the number of months that have elapsed since the date of manufacture.

Confirmation for date of manufacture

Date of manufacture is indicated by a three-part number ①, as shown in the photograph, each indicating month, date and year.

Near the end of charging period, adjust the specific gravity of electrolyte to value specified. After charging, adjust the electrolyte level to the UPPER LEVEL with DISTILLED WATER.

SERVICING

Visually inspect the surface of the battery container. If any signs of cracking or electrolyte leakage from the sides of the battery have occurred, replace the battery with a new one.

If the battery terminals are found to be coated with rust or an acidic white powdery substance, then this can be cleaned away with sandpaper.

Months after manufacturing	Within 6	Within 9	Within 12	Over 12
Necessary charging hours	20	30	40	60

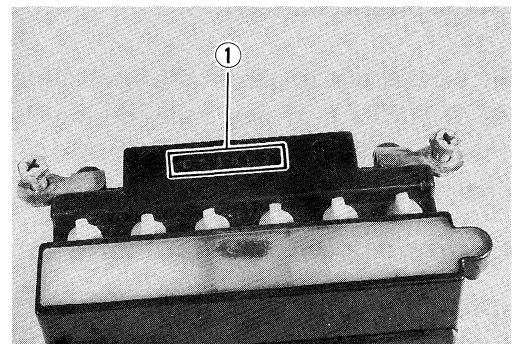
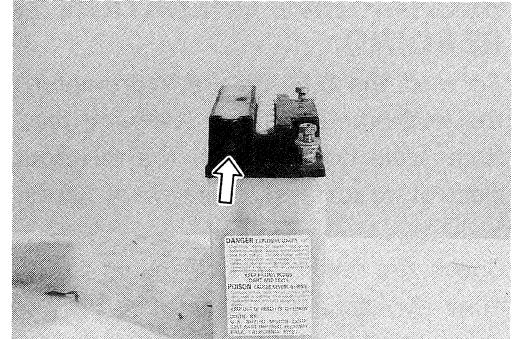
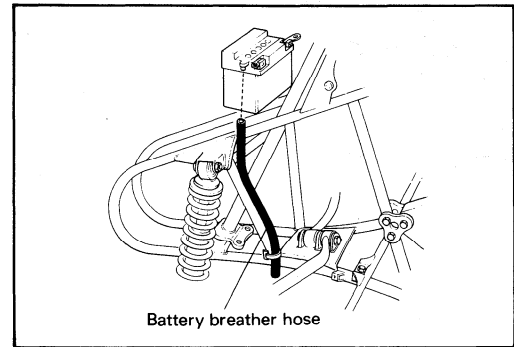

5-13 ELECTRICAL SYSTEM

Check the electrolyte level and add distilled water, as necessary to raise the electrolyte to each cell's UPPER level.

Check the battery for proper charge by taking an electrolyte S.G. reading. If the reading is 1.22 or less, as corrected to 20°C (68°F), it means that the battery is still in a run-down condition and needs recharging.

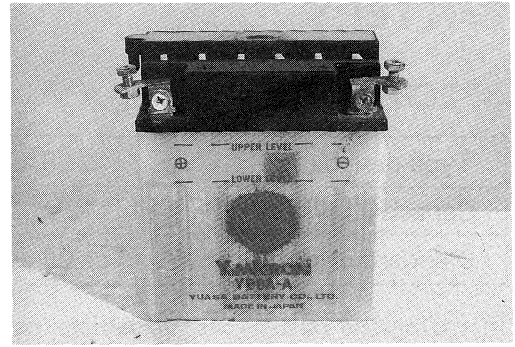

RECHARGING OPERATION BASED ON S.G. READING

To read the S.G. on the hydrometer, bring the electrolyte in the hydrometer to eye level and read the graduations on the float scale bordering on the meniscus (curved-up portion of electrolyte surface), as shown in figure.

Check the reading (as corrected to 20°C) with chart to determine the recharging time in hour by constant-current charging at a charging rate of 1.2 amperes (which is tenth of the capacity of the present battery).

Be careful not to permit the electrolyte temperature to exceed 45°C (113°F), at any time, during the recharging operation. Interrupt the operation, as necessary, to let the electrolyte cool down. Recharge the battery to the specification.

Electrolyte specific gravity: 1.28 at 20°C (68°F)

CAUTION:

Constant-voltage charging, otherwise called "quick" charging, is not recommendable for it could shorten the life of the battery.

09900-28403: Hydrometer

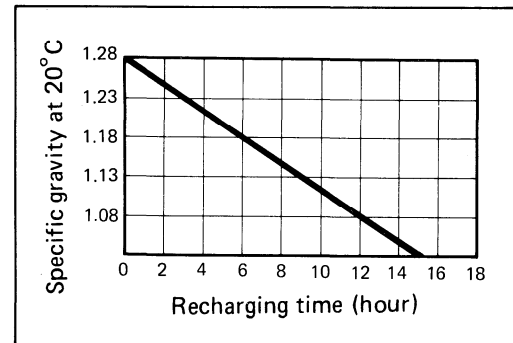
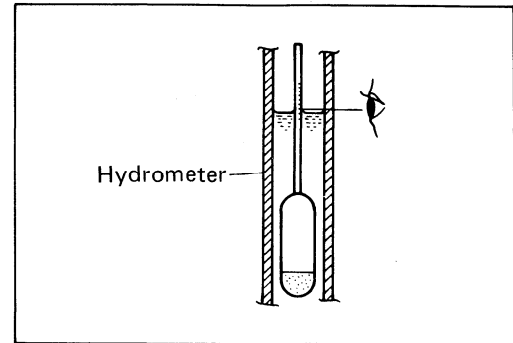
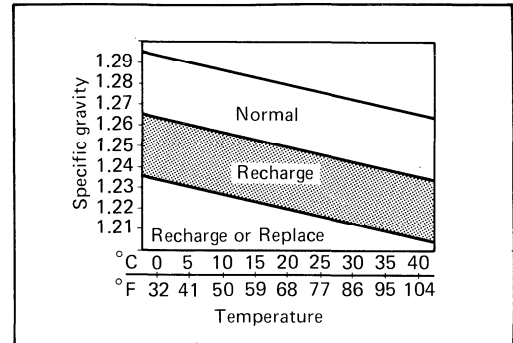

SERVICE LIFE

Lead oxide is applied to the pole plates of the battery which will come off gradually during the service. When the bottom of the battery case becomes full of the sediment, the battery cannot be used any more. If the battery is not charged for a long time, lead sulfate is generated on the surface of the pole plates and will deteriorate the performance (sulfation). Replace the battery with new one in such a case.

When a battery is left for a long term without using, it is apt to subject to sulfation. When the vehicle is not used for more than 1 month (especially during the winter season), recharge the battery once a month at least.

WARNING:

- * Before charging a battery, remove the seal cap from each cell.
- * Keep fire and sparks away from a battery being charged.
- * When removing a battery from the vehicle, be sure to remove the ⊖ terminal first.

CHASSIS

CONTENTS

FRONT AND REAR FENDERS	6- 1
REMOVAL	6- 1
REMOUNTING	6- 3
FRONT WHEEL AND BRAKE	6- 4
REMOVAL	6- 4
INSPECTION AND DISASSEMBLY	6- 6
REASSEMBLY AND REMOUNTING	6- 7
TIRES	6- 8
TIRE REPLACEMENT	6- 8
STEERING AND FRONT SUSPENSION	6-10
REMOVAL AND DISASSEMBLY	6-11
INSPECTION	6-13
REASSEMBLY AND REMOUNTING	6-14
TOE-IN ADJUSTMENT	6-15
REASSEMBLING INFORMATION	6-16
REAR WHEEL	6-17
REMOVAL	6-17
INSPECTION	6-17
REMOUNTING	6-17
REAR BRAKE	6-18
REMOVAL AND DISASSEMBLY	6-18
INSPECTION	6-19
REASSEMBLY AND REMOUNTING	6-19
REAR AXLE HOUSING AND AXLE SHAFT	6-20
REMOVAL	6-20
INSPECTION AND DISASSEMBLY	6-21
REASSEMBLY AND REMOUNTING	6-22
REASSEMBLING INFORMATION	6-23
REAR SWINGARM AND SHOCK ABSORBER	6-24
REMOVAL	6-24
INSPECTION AND DISASSEMBLY	6-25
REASSEMBLY AND REMOUNTING	6-26

FRONT AND REAR FENDERS

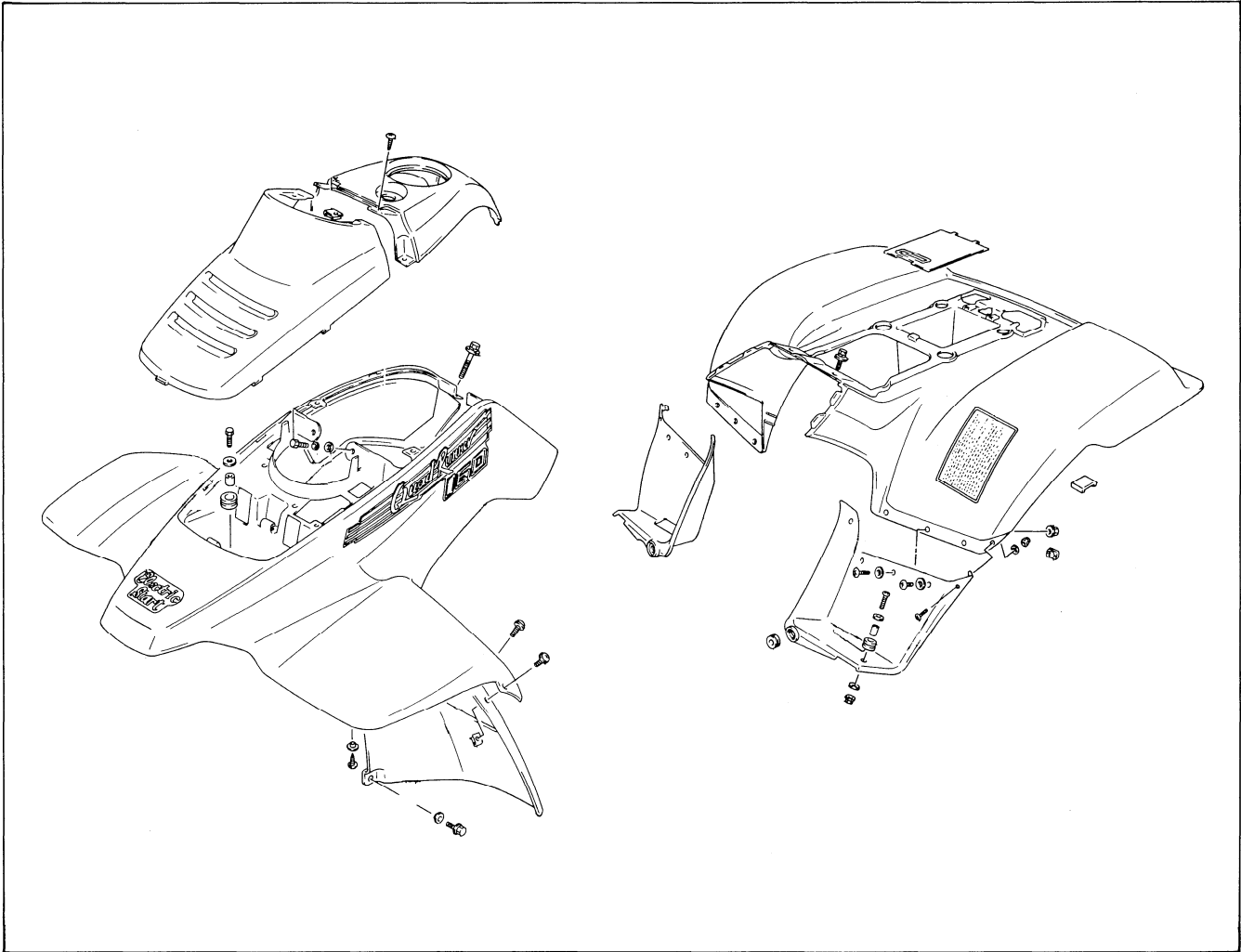

REMOVAL

FRONT FENDER

- Remove the seat.
 - Remove the headlight housing.
 - Remove the indicator panel by removing the ignition switch ring nut and indicator light panel screw.
-
- Remove the front fender cover by removing the screws ①.
 - Remove the reverse cable knob.

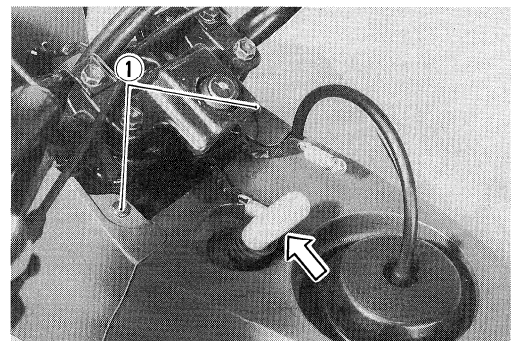
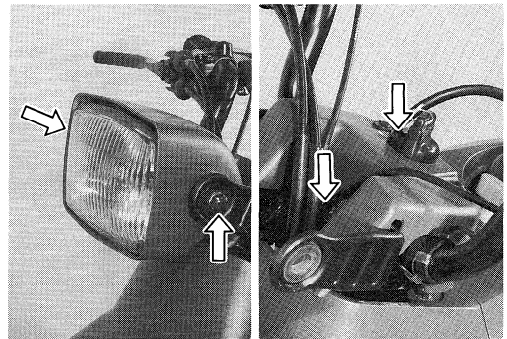

- Remove the fuel tank cover.

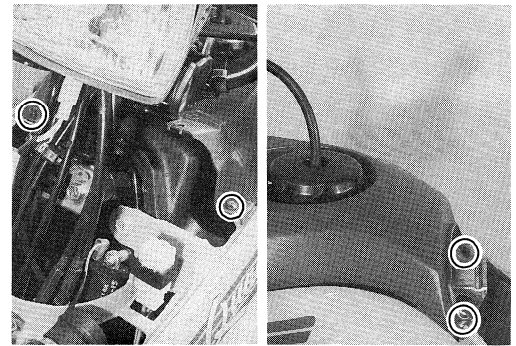

- Remove the battery.

WARNING:

When removing the battery, be sure to disconnect the \ominus lead wire first.

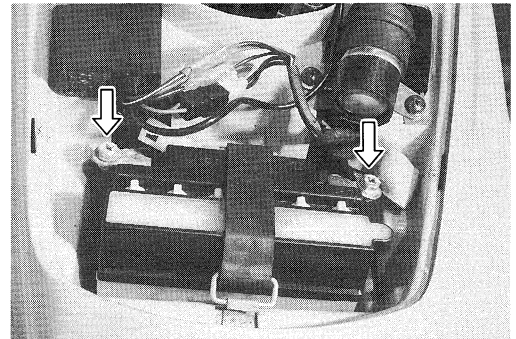

- Disconnect the neutral relay ①, fuse ②, CDI unit ③ and starter relay ④ lead wires.
- Remove the front fender by removing the bolts and screws.

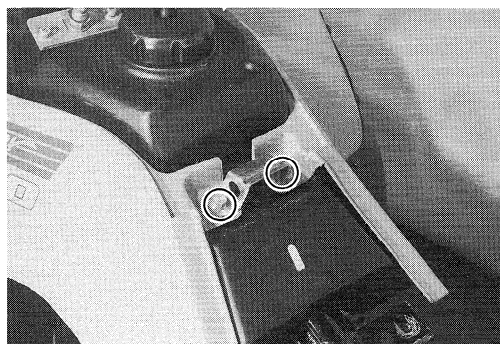
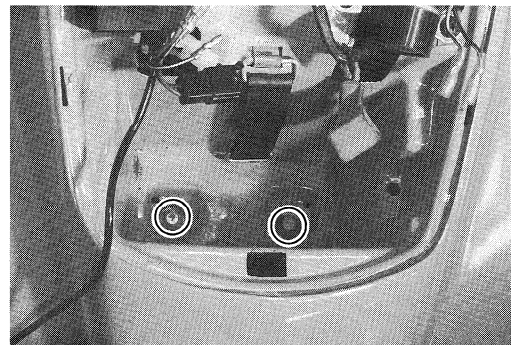
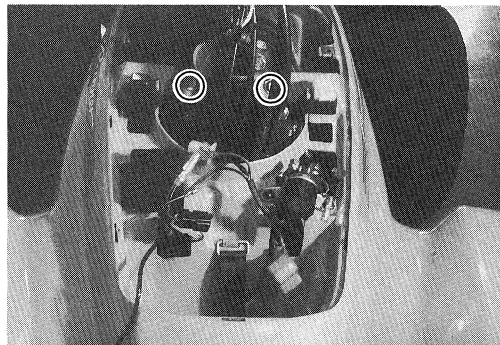
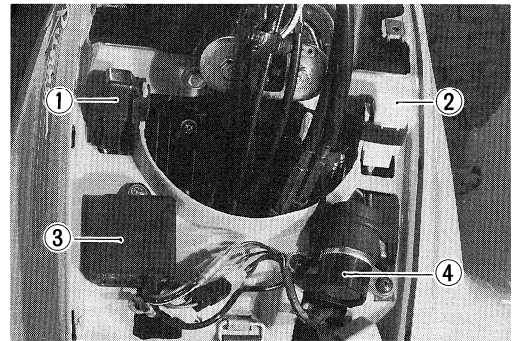

REAR FENDER

- Remove the seat.
- Remove the rear fender by removing the bolts and screws.

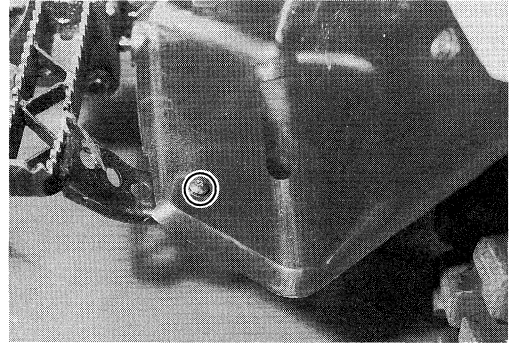
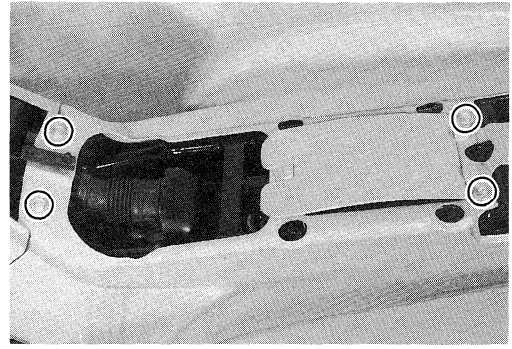

REMOUNTING

- Remount the front and rear fenders in the reverse order of removal.

WARNING:

When mounting the battery, be sure to connect the \oplus lead wire first.

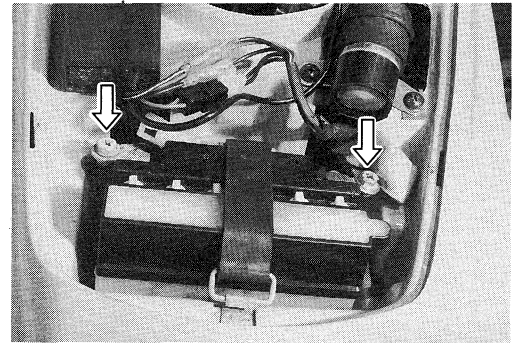

FRONT WHEEL AND BRAKE

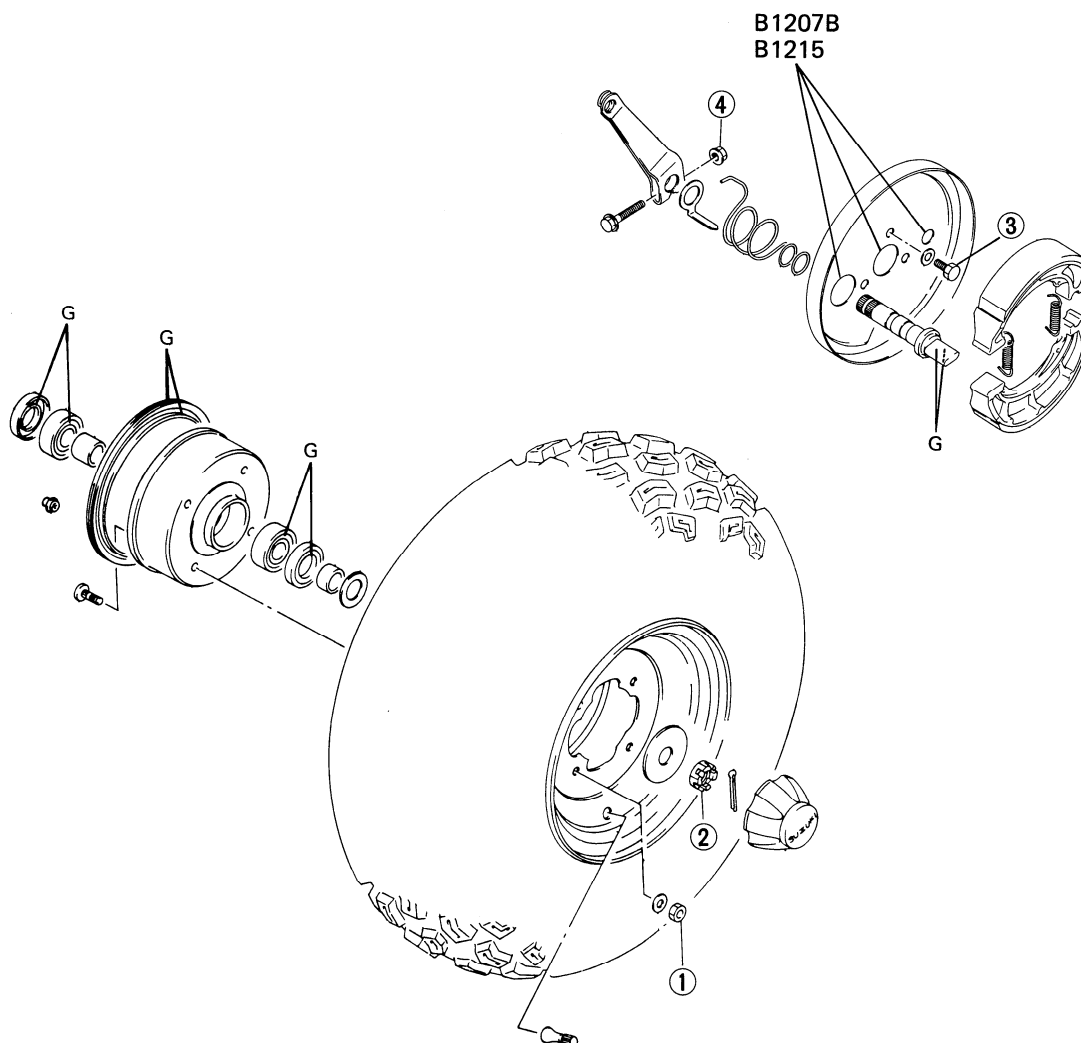

G: Apply SUZUKI Super grease "A"
 (99000-25030 For U.S.A.)
 (99000-25010 For the others)
 B1207B: Apply SUZUKI Bond No. 1207B
 (99104-31140 For U.S.A.)
 B1215: Apply SUZUKI Bond No. 1215
 (99000-31110 For the others)

Tightening torque			
ITEM	N-m	kg-m	lb-ft
①	20 – 31	2.0 – 3.1	14.5 – 22.5
②	50 – 80	5.0 – 8.0	36.0 – 58.0
③	8 – 12	0.8 – 1.2	6.0 – 8.5
④	9 – 13	0.9 – 1.3	6.5 – 9.5

REMOVAL

- Place the vehicle on level ground.
- Loosen the four nuts.
- Support the vehicle by jack or block and remove the front wheel.

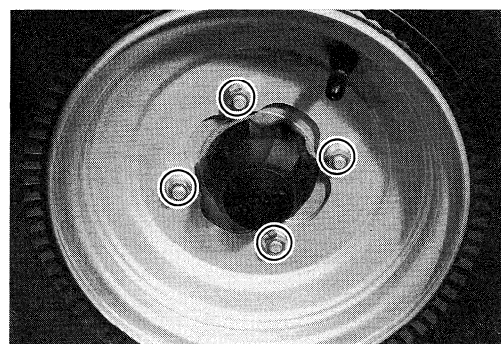

- Remove the cotter pin and wheel hub nut.

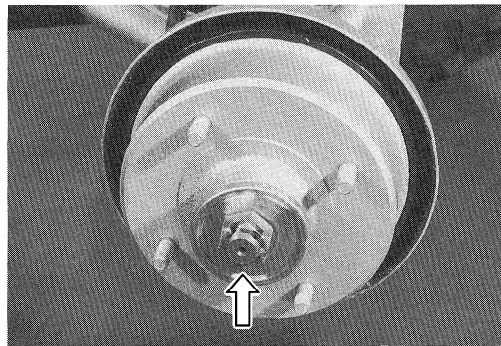

- Remove the rubber plug ①.
- Remove the wheel hub.

NOTE:

If removal of wheel hub is difficult, push the inside of wheel hub with an appropriate bar.

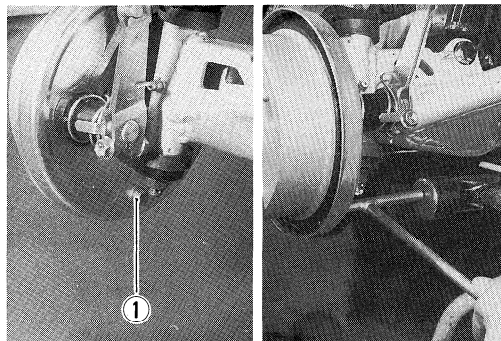

- Remove the brake shoe.

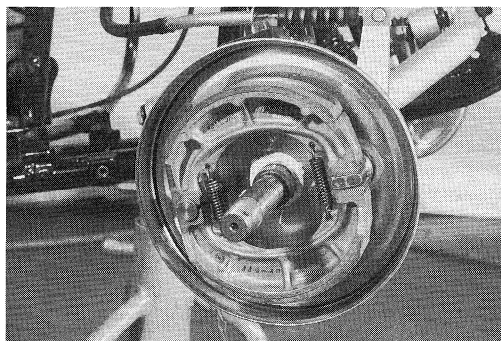

- Remove the brake cam lever and return spring.

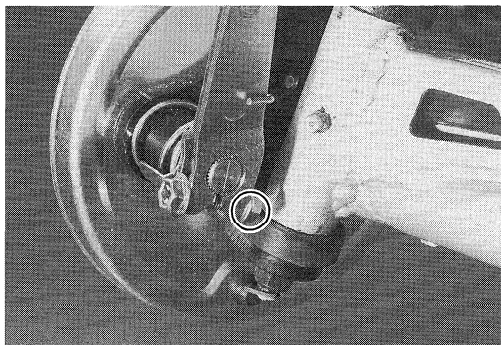

- Remove the front brake plate.

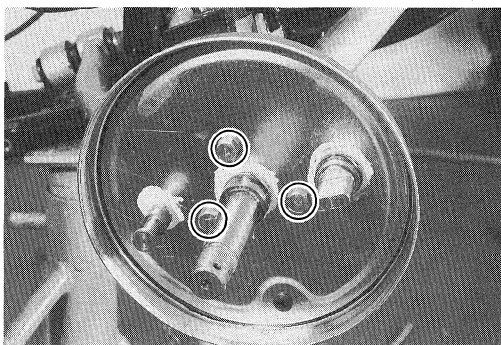

INSPECTION AND DISASSEMBLY

WHEEL HUB BEARING

Inspect the play of bearing inner ring by hand while mounted in the wheel hub.

Rotate the inner ring by hand to inspect if any abnormal noise occurs or rotating smoothly.

Replace the bearing if there is anything unusual.

- Remove the spacer .
- Remove the inner and outer dust seals with the special tool.

09913-50121: Oil seal remover

CAUTION:

The removed dust seals should be replaced with new ones.

- Drive out the both bearing with the special tool in the following procedures.

09941-50110: Bearing remover (Not available in U.S.A.)

- Insert the adapter into the bearing.
- After inserting the wedge bar from the opposite side, lock the wedge bar in the slit of the adapter.
- Drive out the bearing by knocking the wedge bar.

CAUTION:

The removed bearing should be replaced with new one.

TIRE (Refer to page 2-12.)

BRAKE DRUM

Measure the brake drum I.D. to determine the extent of wear and, if the limit is exceeded by the wear noted, replace the brake drum.

The value of this limit is indicated inside of drum.

Service Limit: 120.7 mm (4.75 in)

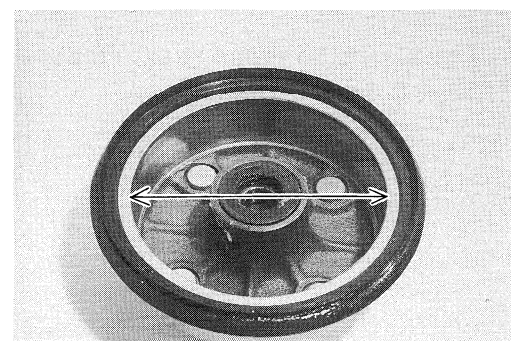
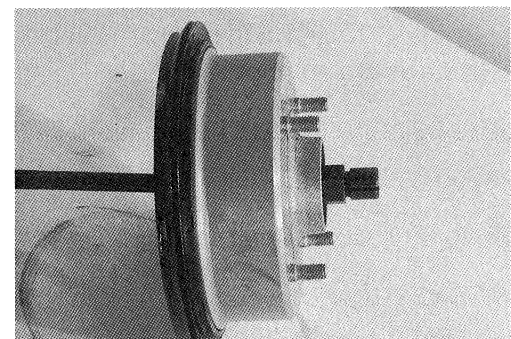
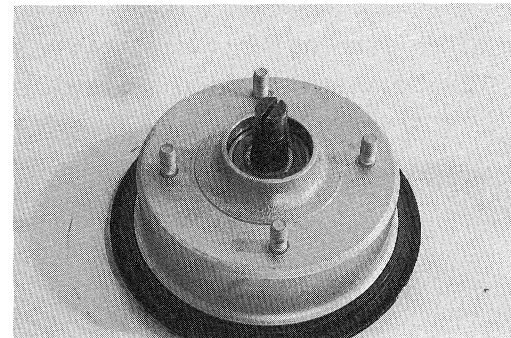
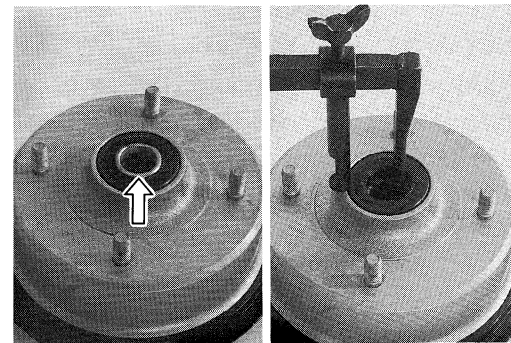
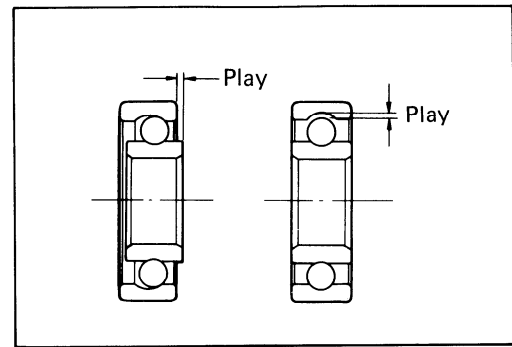

BRAKE SHOE

Check the brake shoe and decide whether it should be replaced or not from the thickness of brake lining.

Service Limit: 1.5 mm (0.06 in)

CAUTION:

Replace the brake shoe as a set, otherwise braking performance will be adversely affected.

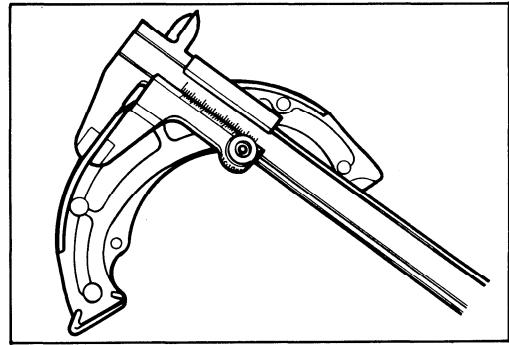

REASSEMBLY AND REMOUNTING

Reassemble and remount the front wheel and brake in the reverse order of removal and disassembly, and also carry out the following steps:

- Install the wheel hub bearings.

NOTE:

First install the inside bearing ①.

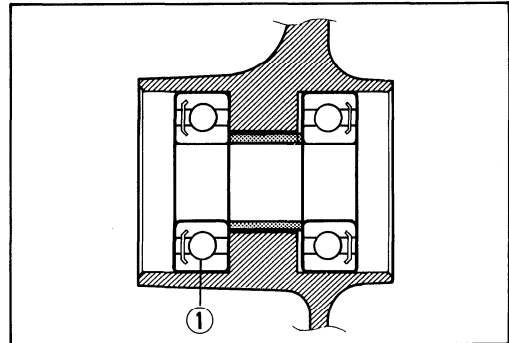

- When installing the brake cam lever, align the punched mark ② of cam lever and punched mark ③ of indicator plate with slit ④ of camshaft.

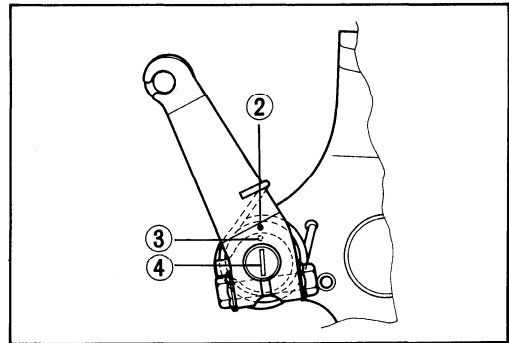

- Apply SUZUKI BOND No. 1207B/1215 to the front brake plate as shown photo.

99104-31140: SUZUKI Bond No. 1207B

99000-31110: SUZUKI Bond No. 1215

- Apply grease. (Refer to pages 6-4 and 6-16.)

WARNING:

Be careful not to apply too much grease to the camshaft and pin. If grease gets on the lining, brake slippage will result.

- Tighten the bolts and nuts to the specified torque. (Refer to pages 6-4 and 6-16.)

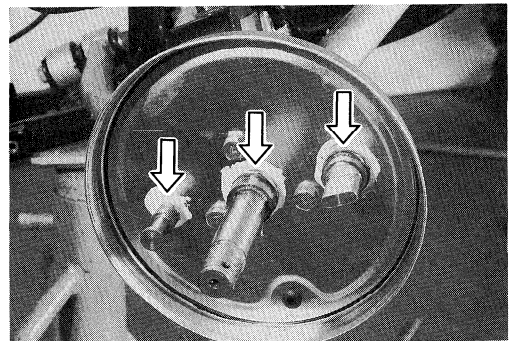

TIRES

TIRE REPLACEMENT

- Remove the front wheel. (Refer to page 6-4.)
- Remove the rear wheel. (Refer to page 6-17.)
- After removing the air valve cap, release the tire pressure by depressing the nozzle.
- Dismount the bead from the rim completely as shown in the illustration.

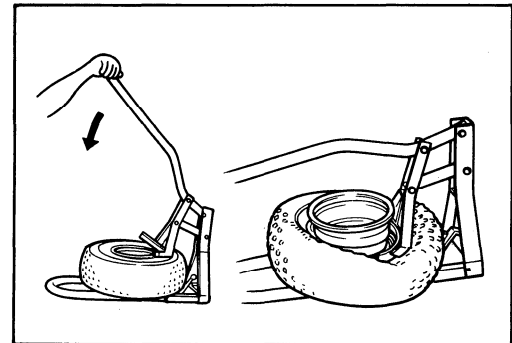

- Using set of tire levers and rim protectors, separate the tire from the rim.

09941-94510: Rim protector

CAUTION:

When using the tire lever, do not scratch or hit the sealing portion (hump) of the wheel or it may cause air-leakage.

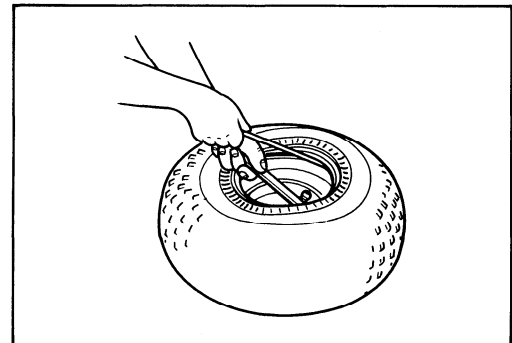

- Apply clean water to the tire bead and the flange of the rim.

CAUTION:

Never use engine oil or gasoline because they will deteriorate the tire.

CAUTION:

The standard tire fitted on this vehicle is AT20 x 7-8☆ for front and AT22 x 10-8☆ for rear.

The use of a tire other than the standard may cause instability. It is highly recommended to use a SUZUKI Genuine tire.

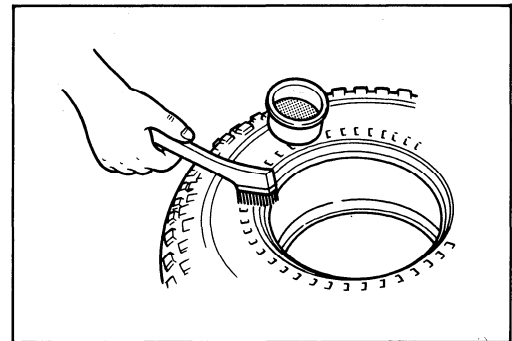

- Mount the tire on the rim by hand as shown in the illustration.

NOTE:

Before mounting the tire on the rim, inspect the sealing portion of rim.

When mounting a tire, be sure to install the tire onto the rim with the arrow on the side wall pointing in the direction of rotation. Also, be certain that outer side of wheel rim faces to the outside.

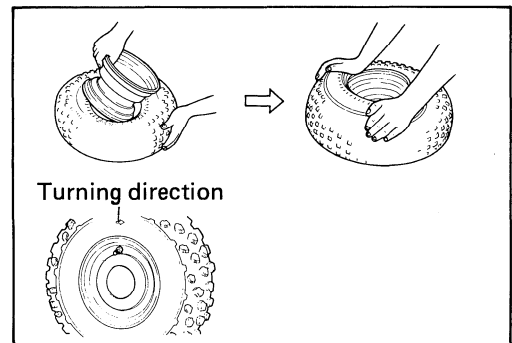

NOTE:

For inspecting the tire refer to the page 2-12.

Before installing the valve core, inspect the core.

- Inflate the tire to seat the bead.

MAX. BEAD SEAT PRESSURE	Front	250 kPa (2.5 kg/cm ² , 36 psi)
	Rear	

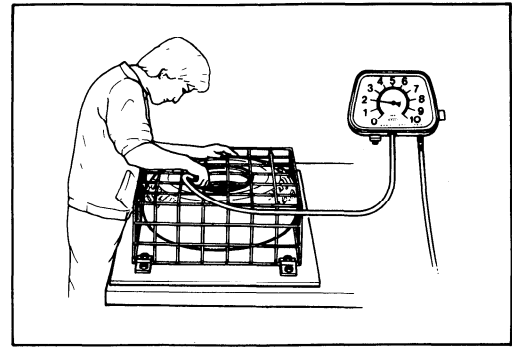

CAUTION:

Place the tire under a protective tire cage or similar protective covering before inflating the tire. To minimize the possibility of tire damage when seating the bead, never exceed the MAX. BEAD SEAT PRESSURE rating shown on the tire.

NOTE:

Check the "rim line" cast on the tire side walls. It must be distance between the rim line and the wheel rim varies, this indicates that the bead is not properly seated. If this is so, deflate the tire completely, and unseat the bead for the both sides. Coat the bead with clean water, and try again.

- As soon as the bead is seated, deflate the tire and reinflate it to the proper operating pressure.

COLD INFLATION TIRE PRESSURE	LOAD CAPACITY					
	UP TO 80 kg (175 lbs)			80 – 130 kg (175 – 285 lbs)		
	kPa	kg/cm ²	psi	kPa	kg/cm ²	psi
FRONT	17.5	0.175	2.5	25	0.25	3.6
REAR	15	0.15	2.2	20	0.20	2.9

CAUTION:

Before inflating the tire, check the MAX. OPERATING PRESSURE rating of the tire. This is indicated by a "☆" following the tire size shown on the sidewall. The number of "☆" on the tire indicates the max. operating pressure as shown below.

	MAX. OPERATING PRESSURE		
	kPa	kg/cm ²	psi
☆	25	0.25	3.6
☆☆	35	0.35	5.1
☆☆☆	45	0.45	6.5

STEERING AND FRONT SUSPENSION

Tightening torque			
ITEM	N·m	kg-m	lb-ft
①	18 - 28	1.8 - 2.8	13.0 - 20.0
②	18 - 28	1.8 - 2.8	13.0 - 20.0
③	18 - 28	1.8 - 2.8	13.0 - 20.0
④	22 - 35	2.2 - 3.5	16.0 - 25.5
⑤	40 - 60	4.0 - 6.0	29.0 - 43.5
⑥	55 - 77	5.5 - 7.7	40.0 - 55.5
⑦	22 - 35	2.2 - 3.5	16.0 - 25.5
⑧	22 - 35	2.2 - 3.5	16.0 - 25.5
⑨	40 - 60	4.0 - 6.0	29.0 - 43.5

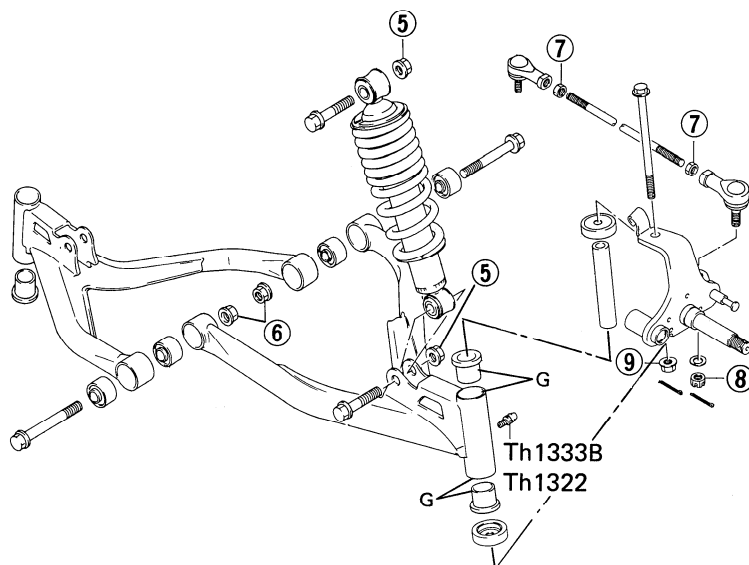
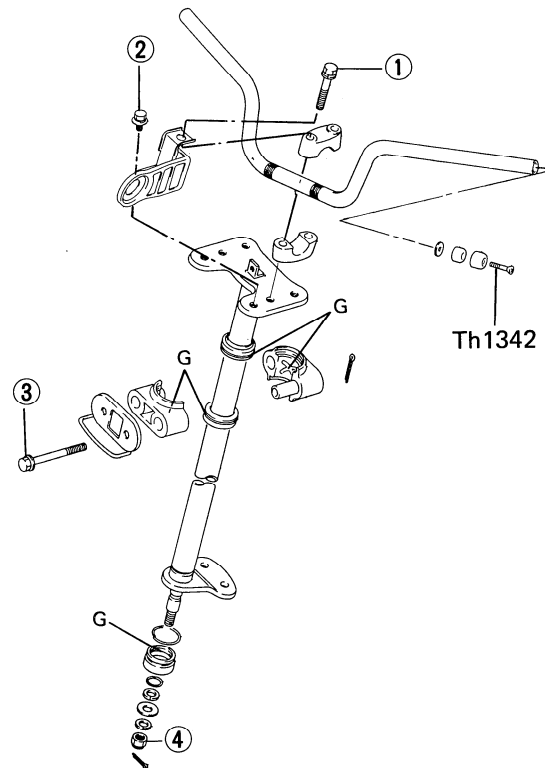

G: Apply SUZUKI Super grease "A" (99000-25030 . . . For U.S.A.)
(99000-25010 . . . For the others)

Th1333B: Apply Thread Lock Super "1333B" (99000-32020 . . . For U.S.A.)

Th1322: Apply Thread Lock Super "1322" (99000-32110 . . . For the others)

Th1342: Apply Thread Lock "1342" (99000-32050)

REMOVAL AND DISASSEMBLY

- Remove the front fender. (Refer to page 6-1.)
 - Remove the front wheel and brake. (Refer to page 6-4.)
 - Remove the tie-rod end nut.
 - Remove the steering knuckle.
-
- Remove the suspension arm mounting bolts and front shock absorber upper mounting bolt.
 - Remove the suspension arm with shock absorber.
-
- Remove the shock absorber.
-
- Remove the dust seals and spacer.
-
- Remove the left-handlebar switch.
 - Remove the throttle lever case.
 - Remove the brake lever holder.

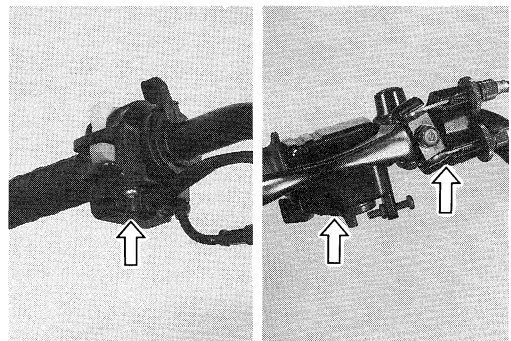
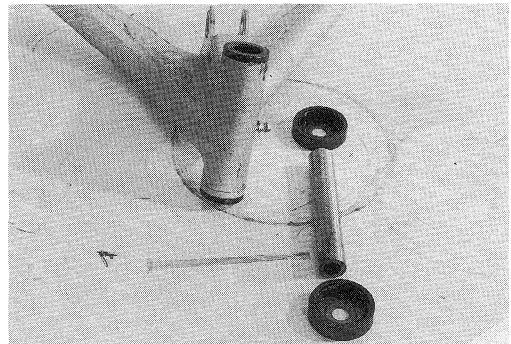
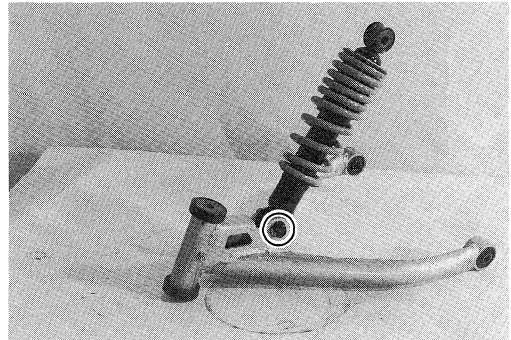
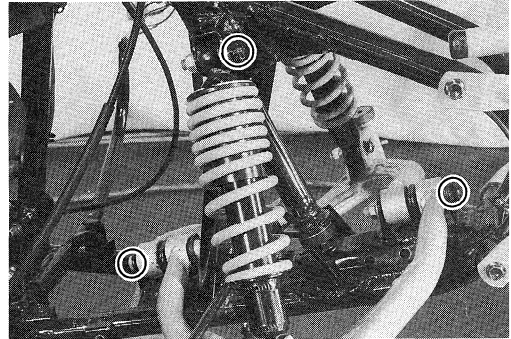
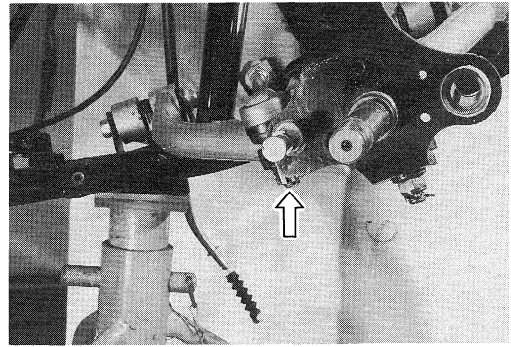

- Remove the front brake cables.

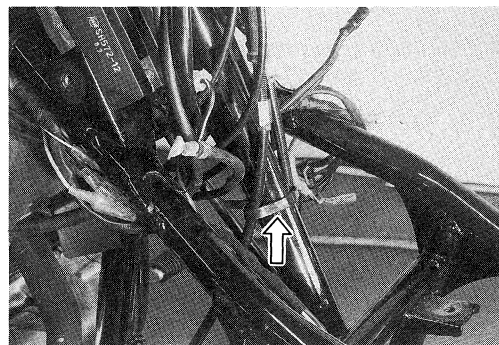

- Remove the headlight housing bracket and handlebar by removing the mounting bolts.

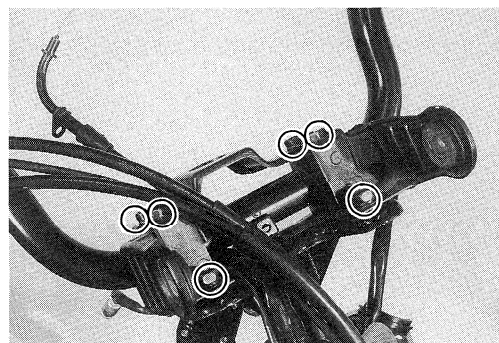

- Remove the tie-rods by removing the cotter pins and nuts.
- Remove the cotter pin and steering shaft lower nut.

NOTE:

The removed cotter pins should be replaced with new ones.

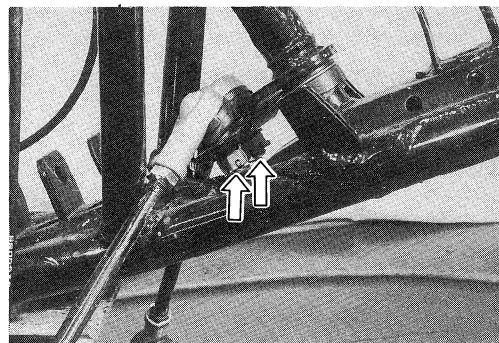

- Separate the tie-rod ends ①, nuts ②, ③, and tie-rods ④.

NOTE:

Inside lock nuts ③ (surface finishing of yellow) are left-hand thread.

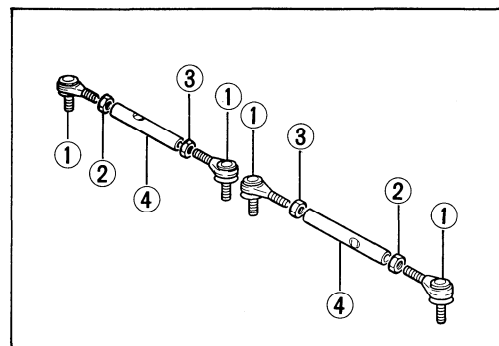

- Remove the cotter pins ⑤, and remove the steering shaft holder bolts ⑥.

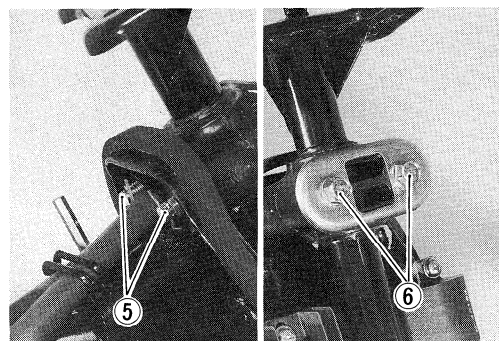

- Remove the steering shaft holders and steering shaft.

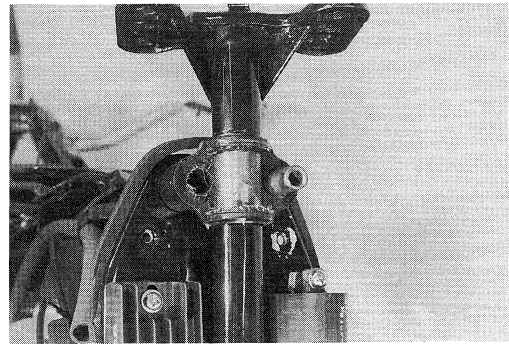

- Remove the clip and dust seal.

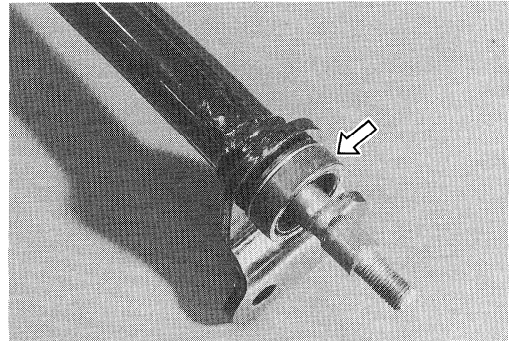

- Remove the dust seal and O-ring from the frame.
- Remove the bushing with an appropriate bar.

CAUTION:

The removed bushing should be replaced with a new one.

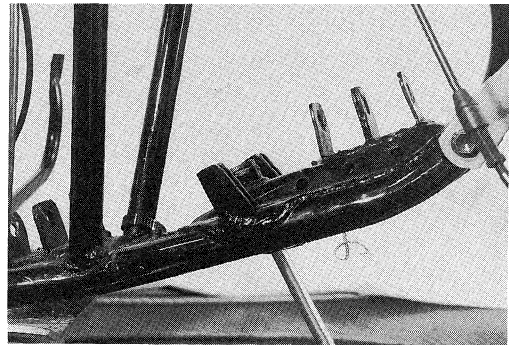

INSPECTION

Inspect the removed parts for the following abnormalities.

- * Handlebar distortion
- * Handlebar clamp wear

DUST SEAL

Inspect the dust seals for damage.

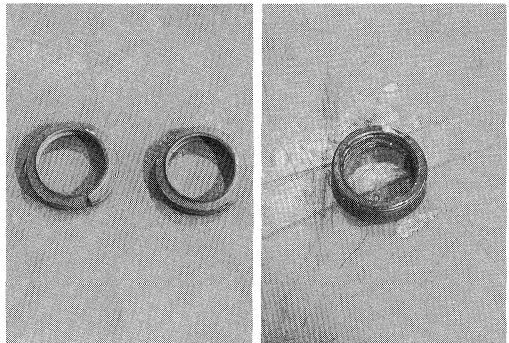

TIE-ROD

Inspect the tie-rod for distortion and the boot for wear.

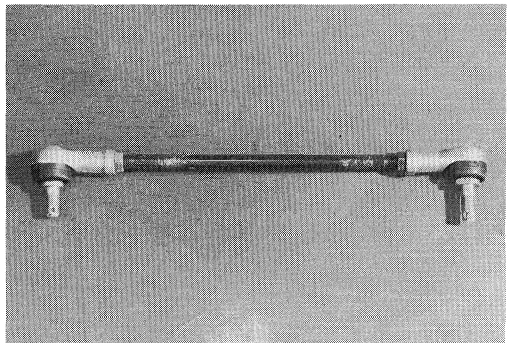

STEERING SHAFT AND HOLDER

Inspect the steering shaft for distortion or bend.

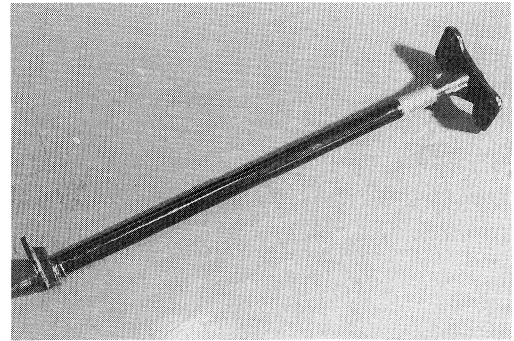

Inspect the two steering shaft holders for wear.

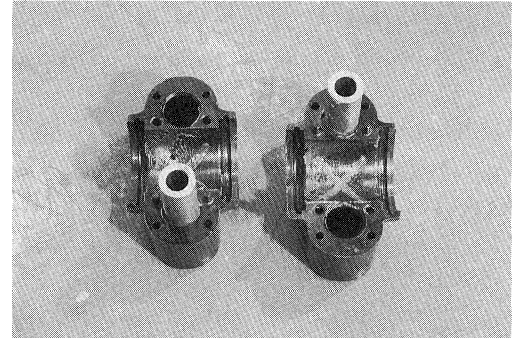
**SHOCK ABSORBER**

Inspect the shock absorber for oil leakage or other damage.

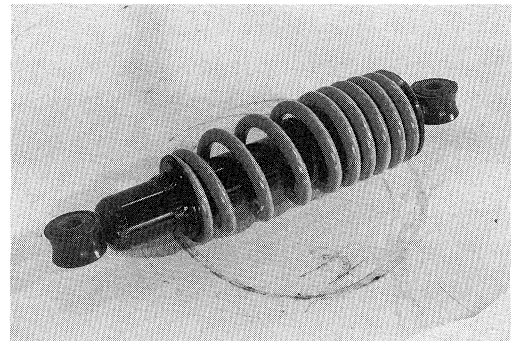
**REASSEMBLY AND REMOUNTING**

Reassemble and remount the steering system in the reverse order of removal and disassembly, and also carry out the following steps:

STEERING BUSHING

Install the new bushing with the special tool.

09924-84510: Bearing installer set

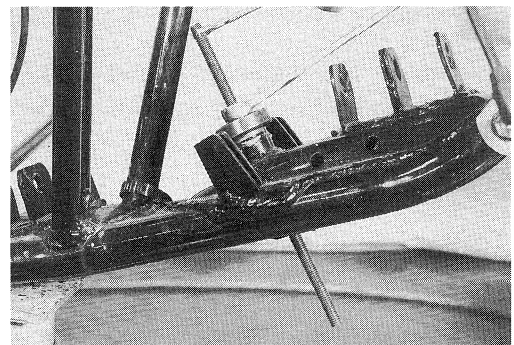
**STEERING SHAFT DUST SEAL****NOTE:**

The dust seal end ① should be mounted on the steering shaft facing forward to prevent entry of dirt.

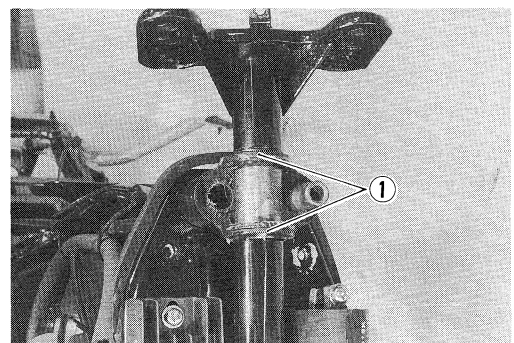

TIE-ROD

- When installing the tie-rod, make sure that the narrow side ① of the tie-rod comes outside.

NOTE:

Inside lock nuts ② (surface finishing of yellow) are left-hand thread.

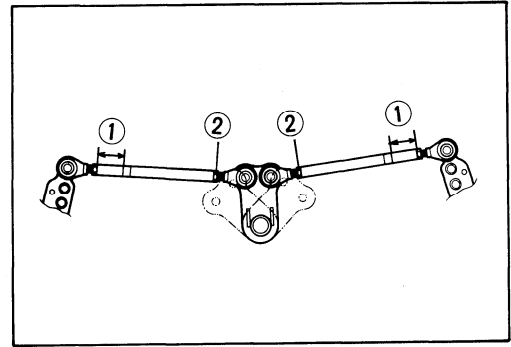

HANDLEBAR

- Set the handlebar to match its punched mark ③ to the mating face of the holder.
- Secure each handlebar clamp in such a way that the clearance ④ ahead of and behind the handlebar should be equalized.
- Apply grease and THREAD LOCK. (Refer to pages 6-10 and 6-16.)
- Tighten the bolts and nuts. (Refer to pages 6-10 and 6-16.)

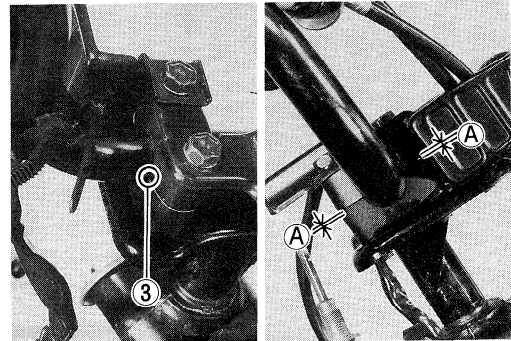

TOE-IN ADJUSTMENT

The procedure for adjusting the toe-in as follows.

- Place the vehicle on level ground and set the handlebar straight. Make sure that all tires are inflated to the standard pressure. (Refer to page 2-12.)
- Place a 75 kg (165 lbs) weight on the seat.
- Loosen the lock nuts ④ on each tie-rod.

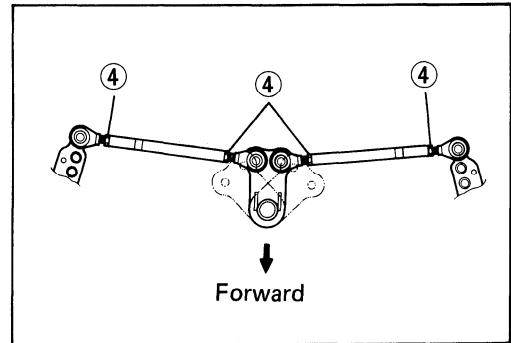

NOTE:

Lock nuts of yellow surface finishing is left-hand thread.

- Measure the distances A and B of front wheels (in illustration) and adjust the tie-rods, right and left, to within the specified range.
A – B = Toe-in

Toe-in: 3 – 11 mm (0.1 – 0.4 in)

- Temporarily tighten the four lock nuts.
- Check that the distances C and D (in illustration) are equal. If the distances C and D are not equal, readjust the tie-rod, right or left, whichever makes the toe-in value closer to the specification. Check the toe-in again by measuring the distances A and B.
- If the toe-in is not within specification, repeat the adjustment as above until proper toe-in value is obtained and at the same time the distances C and D become equal.
- Tighten the four nuts ④ after adjustment of toe-in is made.

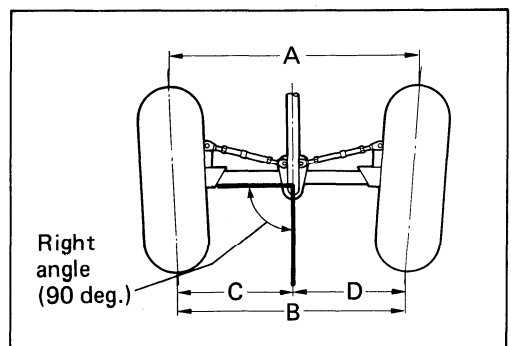
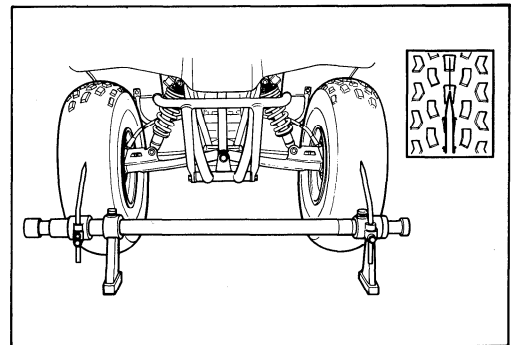

Tightening torque: 22 – 35 N·m

(2.2 – 3.5 kg·m, 16.0 – 25.5 lb-ft)

REASSEMBLING INFORMATION

The diagram illustrates the reassembly of a motorcycle chassis. It features a central chassis frame with various components labeled T1 through T12 and G. T1-T12 represent specific torque points, while G indicates where to apply grease. Callouts include 'FRONT' with an upward arrow, 'VIEW A' pointing to a detail of a bolt, and 'VIEW B' pointing to a detail of a nut. A large arrow labeled 'A' points to the front fork assembly. A note specifies the application of SUZUKI Super grease 'A' and the use of Th1333B or Th1322 thread lock compounds.

Tightening torque

ITEM	N·m	kg·m	lb·ft
T ₁	18-28	1.8-2.8	13.0-20.0
T ₂	18-28	1.8-2.8	13.0-20.0
T ₃	18-28	1.8-2.8	13.0-20.0
T ₄	40-60	4.0-6.0	29.0-43.5
T ₅	22-35	2.2-3.5	16.0-25.5
T ₆	22-35	2.2-3.5	16.0-25.5
T ₇	55-77	5.5-7.7	40.0-55.5
T ₈	22-35	2.2-3.5	16.0-25.5
T ₉	40-60	4.0-6.0	29.0-43.5
T ₁₀	8-12	0.8-1.2	6.0-8.5
T ₁₁	20-31	2.0-3.1	14.5-22.5
T ₁₂	50-80	5.0-8.0	36.0-58.0

G: Apply SUZUKI Super grease "A" (99000-25030 ... For U.S.A.)
 (99000-25010 ... For the others)
Th1333B: Apply Thread Lock Super "1333B" (99000-32020 ... For U.S.A.)
Th1322 : Apply Thread Lock Super "1322" (99000-32110 ... For the others)

REAR WHEEL

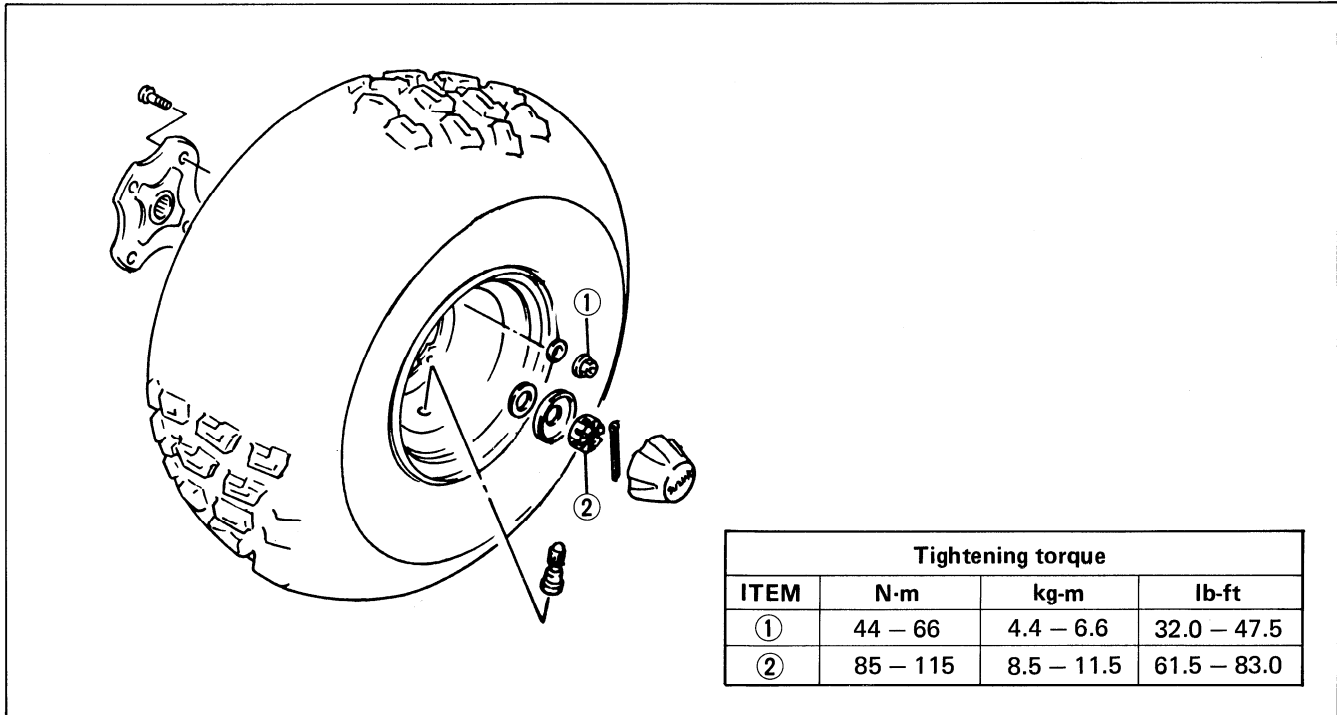

REMOVAL

- Place the vehicle on level ground.
- Support the vehicle by jack or block.
- Remove the rear wheel by removing the four nut ①.
- Remove the cotter pin and wheel hub nut ②.

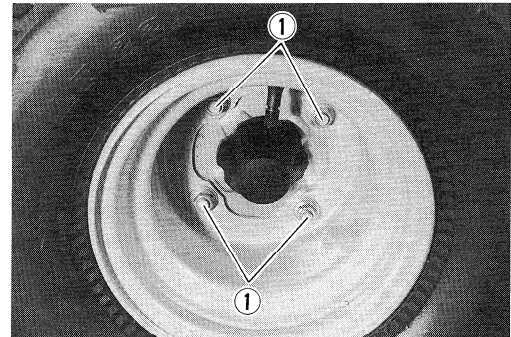

INSPECTION

TIRE (Refer to page 2-12.)

REMountING

Remount the rear wheel in the reverse order of removal.

- Refer to page 6-23.

TIRE AND WHEEL (Refer to page 6-8.)

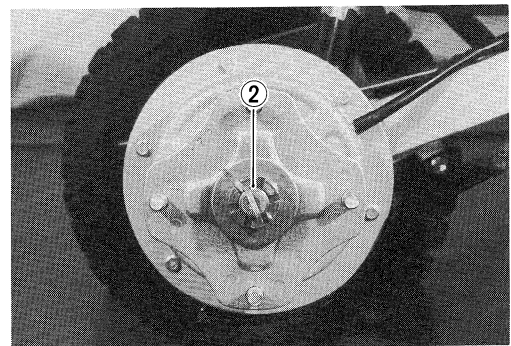

REAR BRAKE

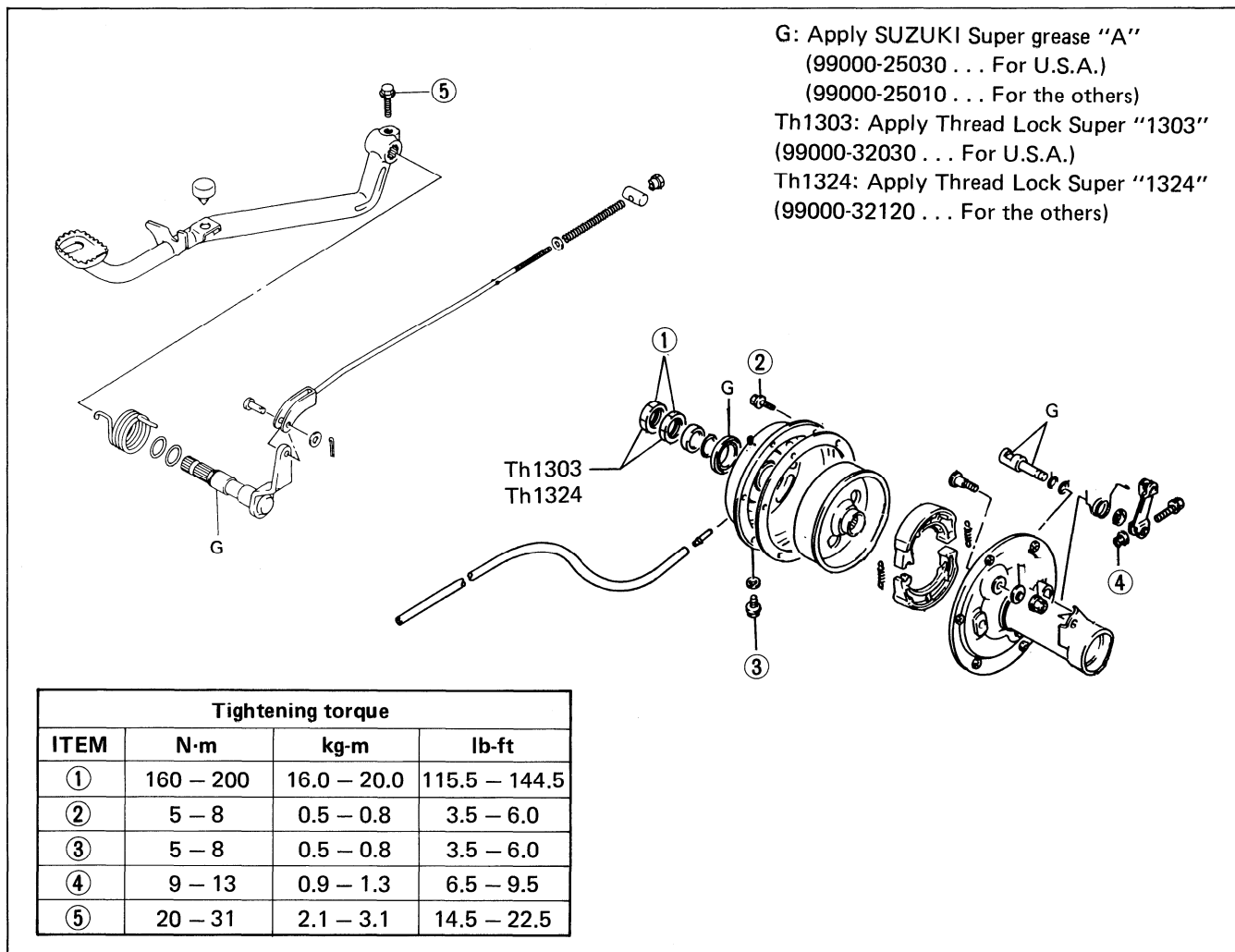

REMOVAL AND DISASSEMBLY

- Remove the right side rear wheel. (Refer to page 6-17.)
- Disconnect the breather hose ①.
- Remove the axle nuts with the special tool.

09940-92410: Rear axle nut wrench (41 mm)

NOTE:

Slightly loosen the two nuts to facilitate later removal before removing the rear wheels.

- Remove the rear brake drum cover.
- Remove the rear brake drum and O-ring ②.

CAUTION:

The removed O-ring should be replaced with a new one.

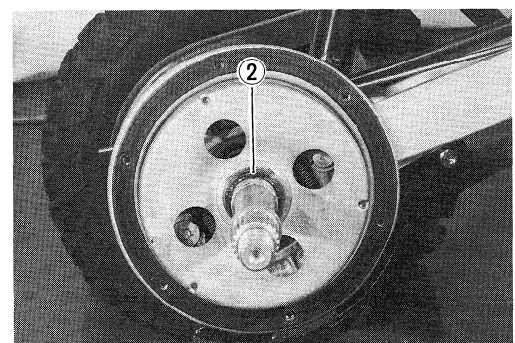
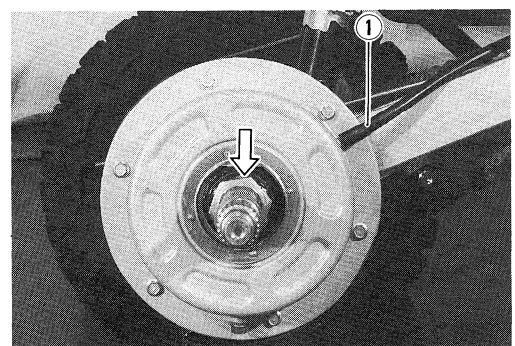

- Remove the brake shoe.

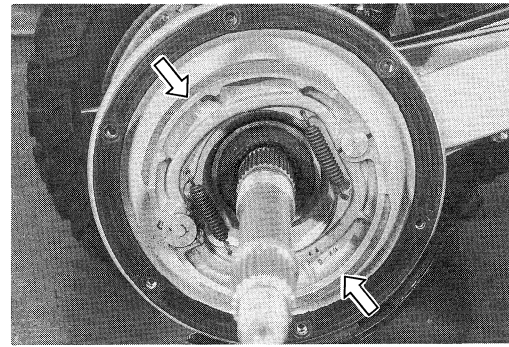

- Remove the brake rod nut ① and brake cam lever.
- Remove the brake pedal and brake pedal arm by removing the bolt.

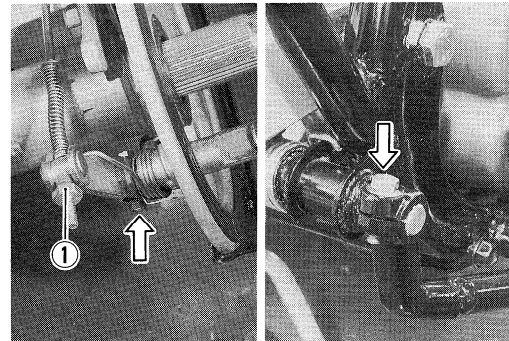

INSPECTION

BRAKE SHOE (Refer to page 6-7.)

BRAKE DRUM

Measure the brake drum I.D. to determine the extent of wear and, if the limit is exceeded by the wear noted, replace the brake drum.

The value of this limit is indicated inside of drum.

Service Limit: 150.7 mm (5.93 in)

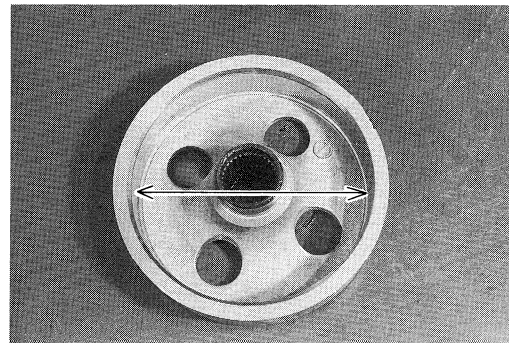

REASSEMBLY AND REMOUNTING

Reassemble and remount the rear brake in the reverse order of removal and disassembly, and also carry out the following steps:

- When installing the brake pedal, align the punched mark ② with slit ③ of the brake pedal.
- When installing the brake cam lever, align the punched mark ④ of cam lever and punched mark ⑤ of indicator plate with slit ⑥ of camshaft.
- Apply grease and THREAD LOCK SUPER "1303/1324". (Refer to pages 6-18 and 6-23.)
- Tighten the bolts and nuts to the specified torque. (Refer to pages 6-18 and 6-23.)

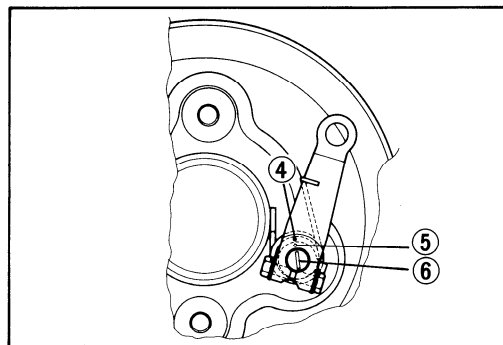
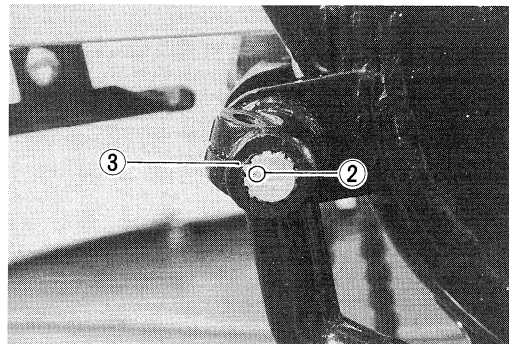

REAR AXLE HOUSING AND AXLE SHAFT

Tightening torque			
ITEM	N·m	kg·m	lb·ft
①	160 – 200	16.0 – 20.0	115.5 – 144.5
②	48 – 72	4.8 – 7.2	34.5 – 52.0
③	70 – 100	7.0 – 10.0	50.5 – 72.5
④	18 – 28	1.8 – 2.8	13.0 – 20.0
⑤	70 – 100	7.0 – 10.0	50.5 – 72.5

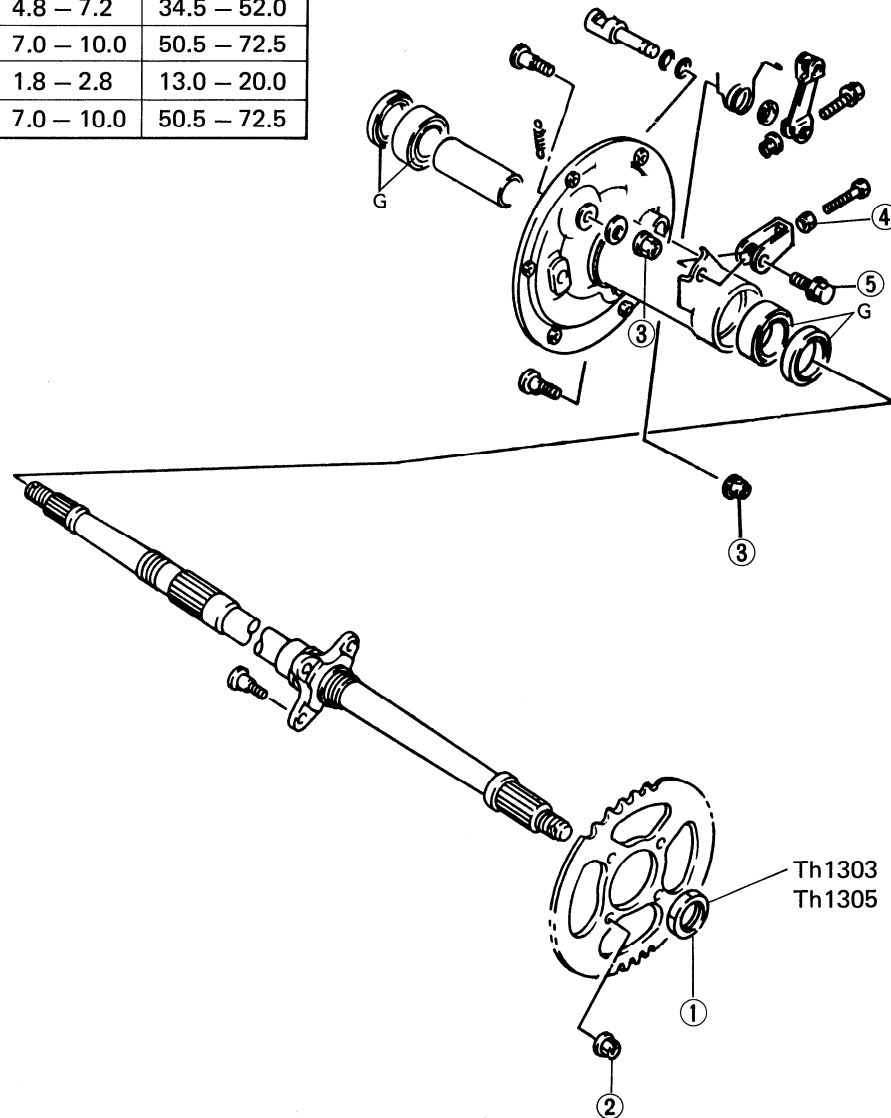

G: Apply SUZUKI Super grease "A" (99000-25030 For U.S.A.)
(99000-25010 For the others)

Th1303: Apply Thread Lock Super "1303" (99000-32030 For U.S.A.)

Th1305: Apply Thread Lock Super "1305" (99000-32100 For the others)

REMOVAL

- Remove the rear wheel. (Refer to page 6-17.)
- Remove the rear brake. (Refer to page 6-18.)
- Remove the chain cover.
- Remove the axle shaft with rear sprocket.

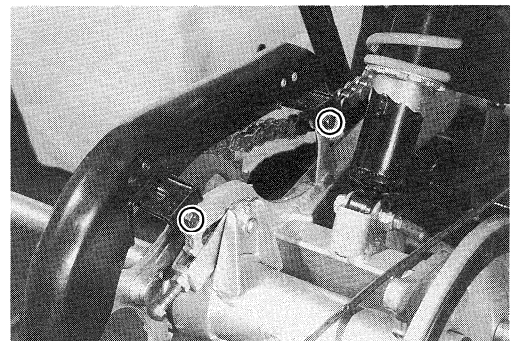

- Remove the rear axle housing.

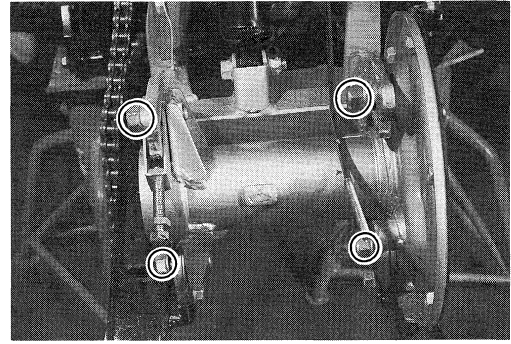

- Remove the rear sprocket flange by removing the nut with the special tool.

09940-92410: Rear axle nut wrench (41 mm)

NOTE:

Slightly loosen the nut to facilitate later removal before removing the rear wheels.

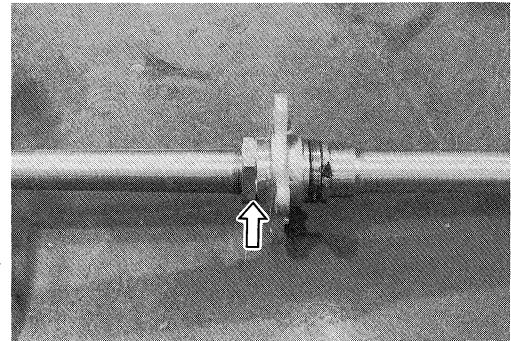

INSPECTION AND DISASSEMBLY

AXLE HOUSING BEARING

Inspect the play of bearing inner ring by hand while mounted in the axle housing.

Rotate the inner ring by hand to inspect if any abnormal noise occurs or rotating smoothly.

Replace the bearing if there is anything unusual.

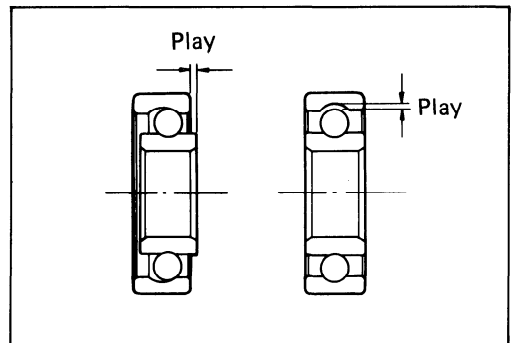

- Remove the dust seals with the special tool.

09913-50121: Oil seal remover

CAUTION:

Replace the removed dust seals with new ones.

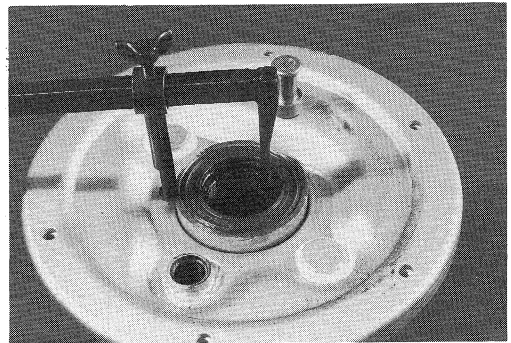

- Remove the right and left bearings and spacer.

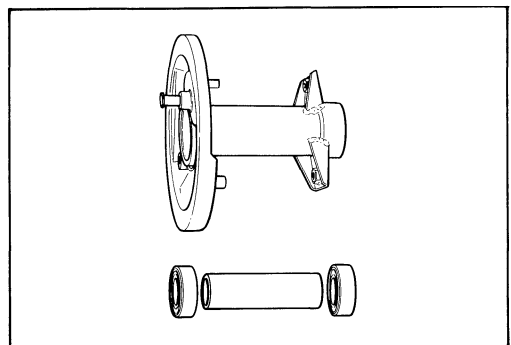

REAR SPROCKET

Inspect the sprocket teeth for wear. If they are worn as illustrated, replace the sprocket and drive chain.

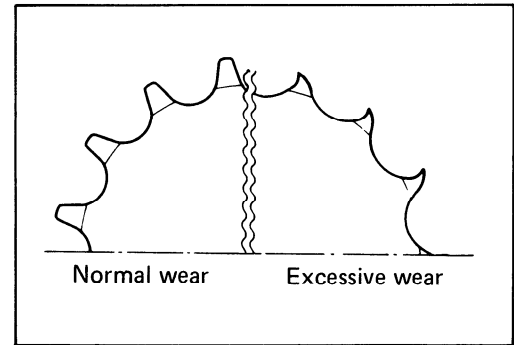

- Remove the rear sprocket.

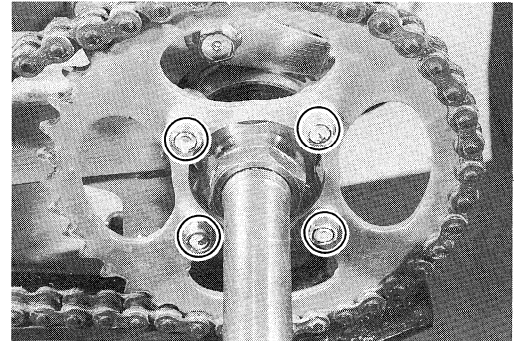
**REAR AXLE SHAFT**

Using a dial gauge, check the axle shaft for runout and replace it if the runout exceeds the limit.

Service Limit: 8.0 mm (0.31 in)

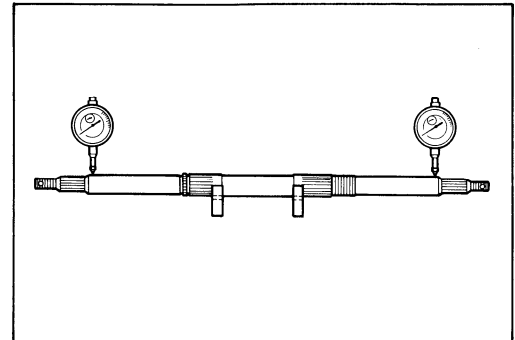
**REASSEMBLY AND REMOUNTING**

Reassemble and remount the rear axle housing in the reverse order of removal and disassembly, and also carry out the following steps:

- Install the bearings with a bearing installer.

NOTE:

First install the bearing for right side.

09913-85210: Bearing installer

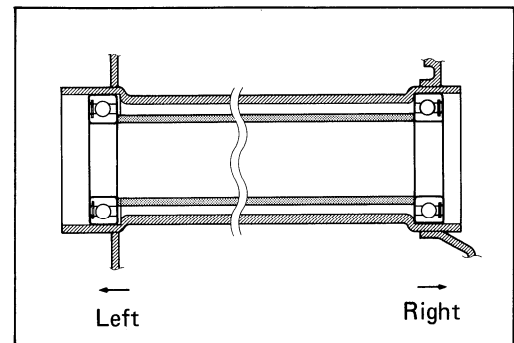

- Apply grease and THREAD LOCK SUPER "1303/1305". (Refer to pages 6-20 and 6-23.)
- Tighten the bolts and nuts to the specified torque. (Refer to pages 6-20 to 6-23.)

REASSEMBLING INFORMATION

G: Apply SUZUKI Super grease "A" (99000-25030 ... For U.S.A.)
 (99000-25010 ... For the others)
 Th1303: Apply Thread Lock Super "1303" (99000-32030 ... For U.S.A.)
 Th1305: Apply Thread Lock Super "1305" (99000-32100 ... For the others)
 Th1324: Apply Thread Lock Super "1324" (99000-32120 ... For the others)

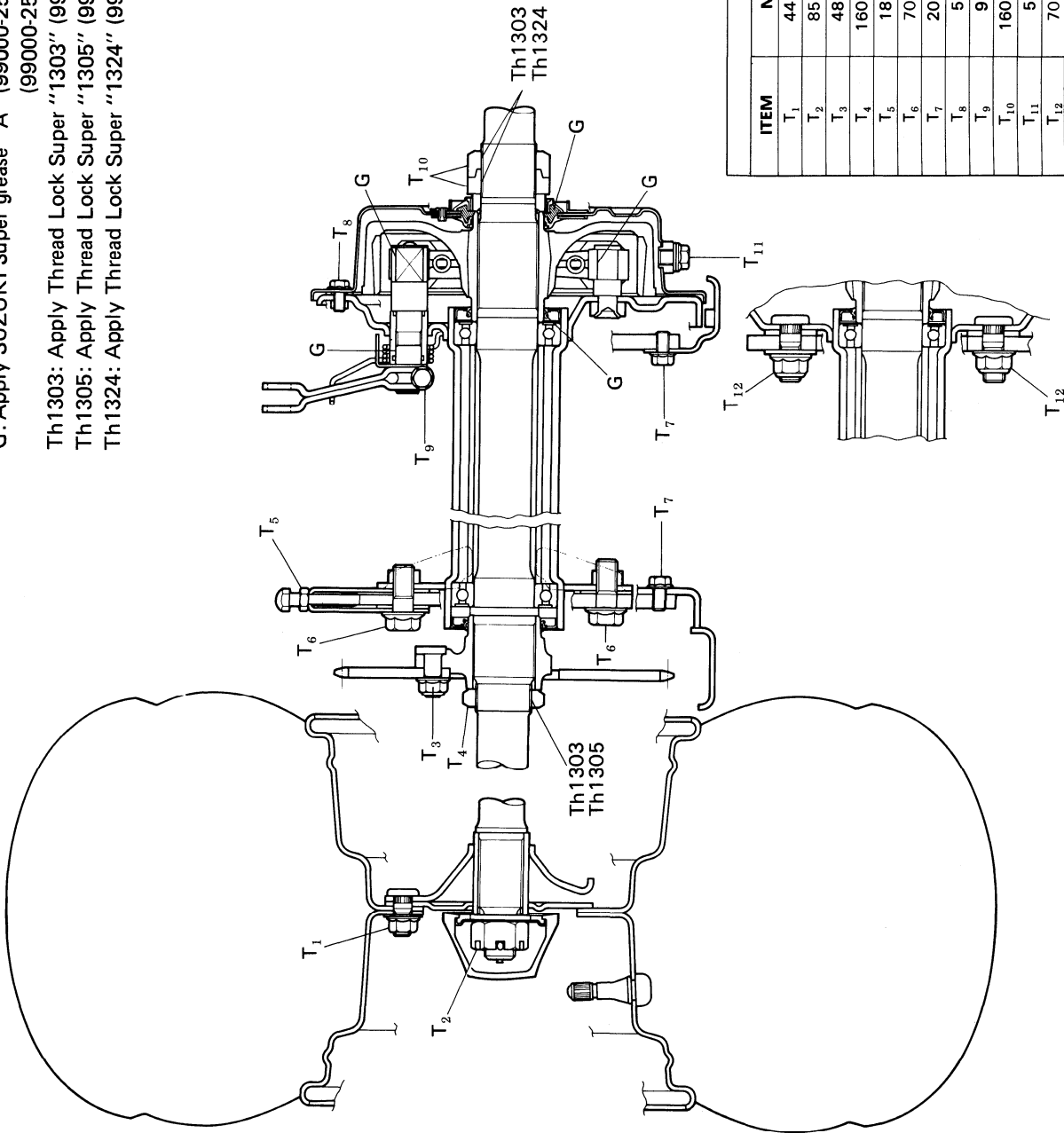

ITEM	Tightening torque		
	N·m	kg·m	lb·ft
T ₁	44-66	4.4-6.6	32.0-47.5
T ₂	85-115	8.5-11.5	61.5-83.0
T ₃	48-72	4.8-7.2	34.5-52.0
T ₄	160-200	16.0-20.0	115.5-144.5
T ₅	18-28	1.8-2.8	13.0-20.0
T ₆	70-100	7.0-10.0	50.5-72.5
T ₇	20-31	2.0-3.1	14.5-22.5
T ₈	5-8	0.5-0.8	3.5-6.0
T ₉	9-13	0.9-1.3	6.5-9.5
T ₁₀	160-200	16.0-20.0	115.5-144.5
T ₁₁	5-8	0.5-0.8	3.5-6.0
T ₁₂	70-100	7.0-10.0	50.5-72.5

REAR SWINGARM AND SHOCK ABSORBER

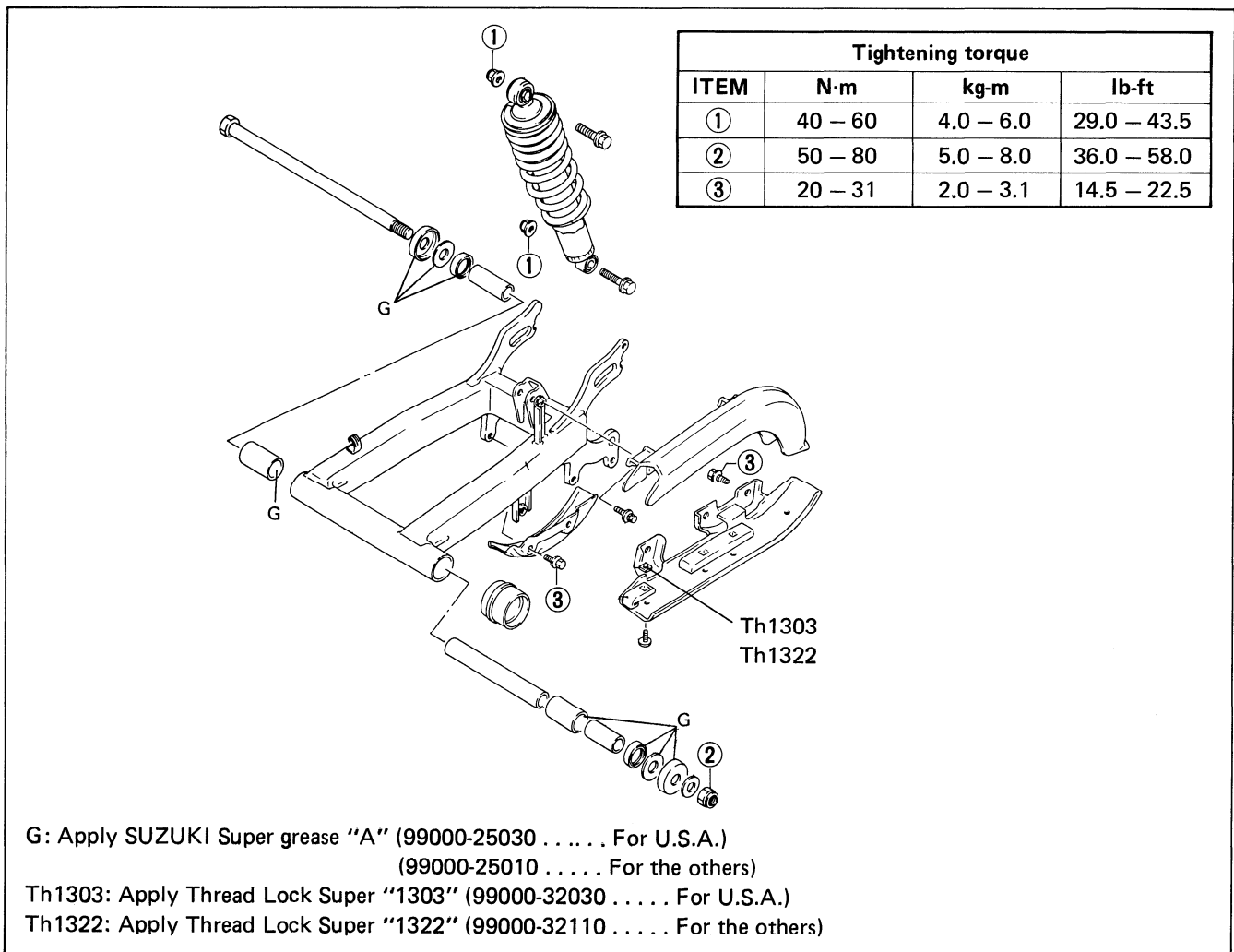

REMOVAL

- Remove the rear fender. (Refer to page 6-4.)
 - Remove the rear wheel. (Refer to page 6-17.)
 - Remove the rear brake. (Refer to page 6-18.)
 - Remove the rear axle housing. (Refer to page 6-20.)
 - Remove the shock absorber upper mounting bolt and swingarm pivot shaft.
 - Remove the swingarm with shock absorber.
-
- Remove the shock absorber.

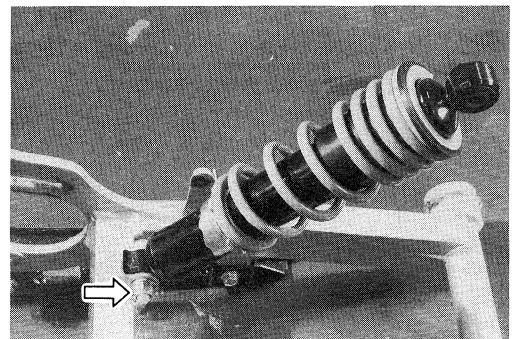
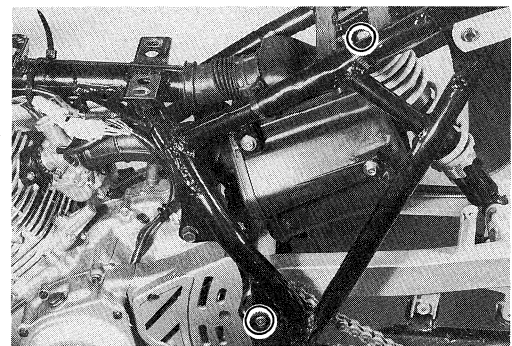

- Remove the rear sprocket guard and rear brake guard.

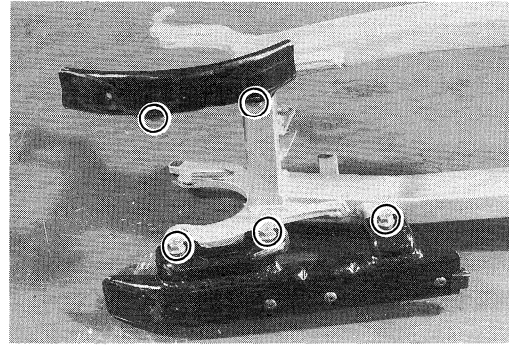

- Remove the dust seals, washers and chain guide.

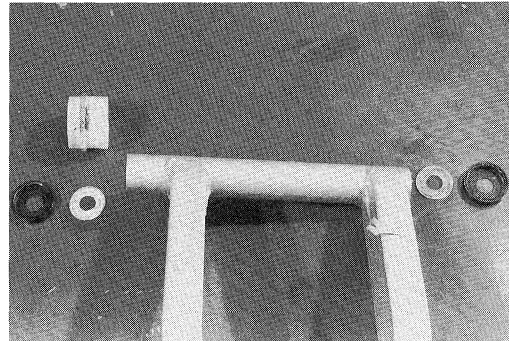

INSPECTION AND DISASSEMBLY

BEARING

Inspect the rotates of swingarm bearing by hand while fixing it in the swingarm.

Rotate the needle roller bearing by hand to inspect whether abnormal noise occurs or it rotates smoothly.

Replace the bearing if there is anything unusual.

- Remove the swingarm bearings with the special tool.

09941-44910: Swingarm bearing remover

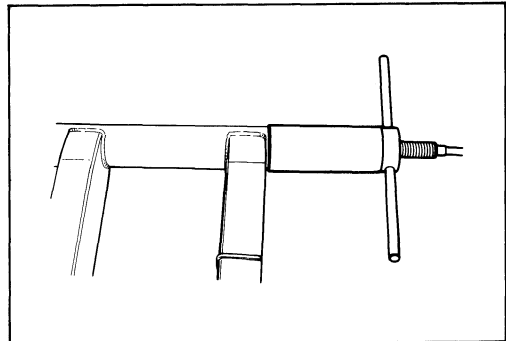

SWINGARM PIVOT SHAFT

Check the pivot shaft for runout with a dial gauge and replace it if the runout exceeds the limit.

Service Limit: 0.3 mm (0.01 in)

09900-20606: Dial gauge (1/100)

09900-20701: Magnetic stand (Not available in U.S.A.)

09900-21304: V-block (Not available in U.S.A.)

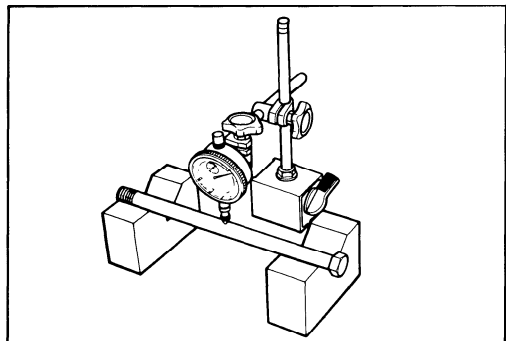

SHOCK ABSORBER

Inspect the shock absorber for oil leakage or other damage.

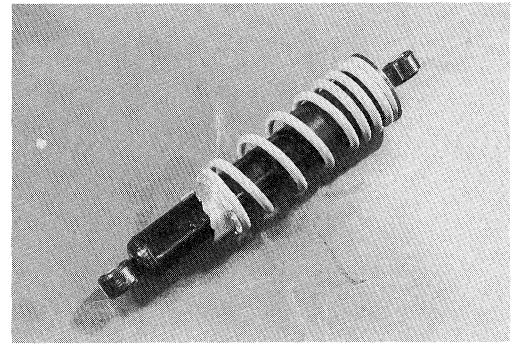

REASSEMBLY AND REMOUNTING

Reassemble and remount the rear swingarm in the reverse order of removal and disassembly, and also carry out the following steps:

SWINGARM BEARING

- Install the bearings with the special tool.

09941-34513: Bearing installer

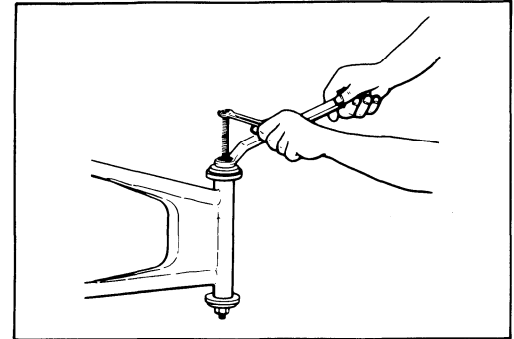

NOTE:

When installing the two bearings, punchmarked side of bearing faces outside.

- Apply grease and THREAD LOCK SUPER "1303/1322". (Refer to page 6-24.)
- Tighten the bolts and nuts to the specified torque. (Refer to page 6-24.)

SERVICING INFORMATION

CONTENTS

TROUBLESHOOTING	7- 1
WIRING DIAGRAM	7- 8
WIRE, CABLE AND HOSE ROUTING	7- 9
SPECIAL TOOLS	7-12
TIGHTENING TORQUE	7-14
SERVICE DATA	7-17

TROUBLESHOOTING

ENGINE

Complaint	Symptom and possible causes	Remedy
Engine will not start or is hard to start	<ol style="list-style-type: none"> 1. Valve clearance out of adjustment 2. Worn valve guides or poor seating of valves. 3. Valves mistiming. 4. Piston rings excessively worn. 5. Worn-down cylinder bore. 6. Poor seating or spark plug. <p>Plug not sparking</p> <ol style="list-style-type: none"> 1. Fouled spark plug. 2. Wet spark plug. 3. Defective magneto. 4. Defective CDI unit. 5. Defective ignition coil. 6. Open or short circuit in high-tension wire. <p>No fuel reaching the carburetor</p> <ol style="list-style-type: none"> 1. Clogged fuel tank vent hose. 2. Defective carburetor float valve. 3. Clogged fuel pipe. 4. Clogged fuel filter. 	<p>Adjust. Repair or replace. Adjust. Replace. Replace or rebore. Retighten.</p> <p>Clean or replace. Clean and dry. Replace. Replace. Replace. Replace.</p> <p>Clean. Replace. Clean or replace. Clean or replace.</p>
Engine stalls easily.	<ol style="list-style-type: none"> 1. Fouled spark plug. 2. Defective magneto. 3. Defective CDI unit. 4. Clogged fuel pipe. 5. Clogged jets in carburetor. 6. Valve clearance out of adjustment. 	<p>Clean. Replace. Replace. Clean. Clean. Adjust.</p>
Noisy engine	<p>Excessive valve noise</p> <ol style="list-style-type: none"> 1. Valve clearance too large. 2. Weakened or broken valve spring. 3. Worn down rocker arm or rocker arm shaft. <p>Noise appears to come from piston</p> <ol style="list-style-type: none"> 1. Piston or cylinder worn down. 2. Combustion chamber fouled with carbon. 3. Piston pin or piston pin bore worn. 4. Piston ring or ring groove worn. <p>Noise seems to come from timing chain</p> <ol style="list-style-type: none"> 1. Stretched chain. 2. Worn sprockets. 3. Tension adjuster not working. <p>Noise seems to come from clutch</p> <ol style="list-style-type: none"> 1. Worn splines off countershaft or hub. 2. Worn teeth of clutch plates. 3. Distorted clutch plates, driven and drive. <p>Noise seems to come from crankshaft</p> <ol style="list-style-type: none"> 1. Worn or burnt bearing. 2. Big-end bearing worn or burnt. 3. Thrust clearance too large. 	<p>Adjust. Replace. Replace.</p> <p>Replace. Clean. Replace. Replace.</p> <p>Replace. Replace. Repair or replace.</p> <p>Replace. Replace. Replace.</p> <p>Replace. Replace. Replace.</p>

Complaint	Symptom and possible causes	Remedy
Noisy engine	Noise seems to come from transmission 1. Gears worn or rubbing. 2. Badly worn splines. 3. Primary gears worn or rubbing. 4. Badly worn bearing.	Replace. Replace. Replace. Replace.
Slipping clutch	1. Clutch control out of adjustment or loss of play. 2. Weakened clutch spring. 3. Worn or distorted pressure plate. 4. Distorted clutch plates, driven and drive.	Adjust. Replace. Replace. Replace.
Dragging clutch	1. Clutch control out of adjustment or too much play. 2. Some clutch springs weakened while others are not. 3. Distorted pressure plate or clutch plates. 4. Wrong viscosity engine oil.	Adjust. Replace. Replace. Change.
Transmission will not shift	1. Broken gearshift cam. 2. Distorted gearshift fork. 3. Worn gearshift pawl. 4. Worn or damaged clutch release mechanism.	Replace. Replace. Replace. Replace.
Transmission will not shift back	1. Broken reverse shift cam. 2. Shift shafts are rubbing or sticky. 3. Distorted or worn gearshift fork.	Replace. Repair. Replace.
Transmission jumps out of gear	1. Worn shifting gears on driveshaft or countershaft. 2. Distorted or worn gearshift fork. 3. Weakened cam stopper spring on gearshift cam. 4. Worn gearshift pawl. 5. Worn gearshift cam.	Replace. Replace. Replace. Replace. Replace.
Engine idles poorly.	1. Valve clearance out of adjustment. 2. Poor seating of valve. 3. Defective valve guide. 4. Worn rocker arm or arm shaft. 5. Defective magneto. 6. Defective CDI unit. 7. Spark plug gap too wide. 8. Defective ignition coil resulting in weak sparking. 9. Float-chamber fuel level out of adjustment in carburetor. 10. Clogged jet. 11. Improper set pilot screw.	Adjust. Replace. Replace. Replace. Replace. Adjust or replace. Replace. Adjust. Clean. Adjust.
Engine runs poorly in high speed range	1. Valve spring weakened. 2. Valve timing out of adjustment. 3. Worn cam or rocker arm. 4. Spark plug gap too narrow. 5. Defective ignition coil. 6. Float-chamber fuel level too low. 7. Clogged air cleaner element. 8. Clogged fuel pipe, resulting in inadequate fuel supply to carburetor.	Replace. Adjust. Replace. Repair. Replace. Adjust. Clean. Clean and prime.
Dirty or heavy exhaust smoke	1. Too much engine oil in the engine. 2. Worn piston ring or cylinder. 3. Worn valve guide. 4. Cylinder wall scored or scuffed. 5. Worn valve stem. 6. Defective stem seal.	Check with inspection window, drain out excess oil. Replace. Replace. Replace. Replace. Replace.

7-3 SERVICING INFORMATION

Complaint	Symptom and possible causes	Remedy
Engine lacks power	<ol style="list-style-type: none"> 1. Loss of valve clearance. 2. Weakened valve spring. 3. Valve timing out of adjustment. 4. Worn piston ring or cylinder. 5. Poor seating of valve. 6. Fouled spark plug. 7. Worn rocker arm or shaft. 8. Spark plug gap incorrect. 9. Clogged jet in carburetor. 10. Float-chamber fuel level out of adjustment. 11. Clogged air cleaner element. 12. Too much engine oil. 13. Sucking air around intake pipe. 	Adjust. Replace. Adjust. Replace. Repair. Clean or replace. Replace. Adjust or replace. Clean. Adjust. Clean. Drain out excess oil. Retighten or replace.
Engine overheats	<ol style="list-style-type: none"> 1. Heavy carbon deposit on piston crown. 2. Not enough oil in the engine. 3. Defective oil pump or clogged circuit. 4. Fuel level too low in float chamber. 5. Air leak from intake pipe. 6. Use of incorrect engine oil. 	Clean. Add oil. Repair or clean. Adjust. Retighten or replace. Change.

CARBURETOR

Complain	Symptom and possible causes	Remedy
Trouble with starting	<ol style="list-style-type: none"> 1. Starter jet is clogged. 2. Starter pipe is clogged. 3. Air leaking from a joint between starter body and carburetor. 4. Starter plunger is not operating properly. 	Clean. Clean. Check starter body and carburetor for tightness, adjust and replace gasket. Check and adjust.
Idling or low-speed trouble	<ol style="list-style-type: none"> 1. Pilot jet, pilot air jet are clogged or loose. 2. Pilot outlet or bypass is clogged. 3. Improperly set pilot screw. 4. Starter plunger is not fully closed. 5. Incorrect float height. 	Check and clean. Check and clean. Adjust. Check and adjust. Adjust.
Medium-or high-speed trouble	<ol style="list-style-type: none"> 1. Main jet or main air jet is clogged. 2. Needle jet is clogged. 3. Throttle valve is not operating properly. 4. Filter is clogged. 5. Incorrect float height. 6. Starter plunger is not fully closed. 	Check and clean. Check and clean. Check throttle valve for operation. Check and clean. Adjust. Check and adjust.
Overflow and fuel level fluctuations.	<ol style="list-style-type: none"> 1. Needle valve is worn or damaged. 2. Spring in needle valve is broken. 3. Float is not working properly. 4. Foreign matter has adhered to needle valve. 5. Fuel level is too high or low. 	Replace. Replace. Check and adjust. Clean. Adjust float height.

ELECTRICAL

Complaint	Symptom and possible causes	Remedy
No sparking or poor sparking	<ol style="list-style-type: none"> 1. Defective ignition coil. 2. Defective spark plug. 3. Defective magneto. 4. Defective CDI unit. 5. Defective pick-up coil. 	Replace. Replace. Replace. Replace. Replace.
Spark plug soon becomes fouled with carbon	<ol style="list-style-type: none"> 1. Mixture too rich. 2. Idling speed set too high. 3. Incorrect gasoline. 4. Dirty element in air cleaner. 	Adjust carburetor. Adjust carburetor. Change. Clean.
Spark plug becomes fouled too soon	<ol style="list-style-type: none"> 1. Worn piston ring. 2. Piston or cylinder worn. 3. Excessive clearance of valve stem in valve guide 4. Worn stem oil seal. 	Replace. Replace. Replace. Replace.
Spark plug electrodes overheat or burn.	<ol style="list-style-type: none"> 1. The engine overheats. 2. Spark plug loose. 3. Mixture too lean. 	Tune up. Retighten. Adjust carburetor.
Bulb does not light	<ol style="list-style-type: none"> 1. Blown bulb. 2. Open or short in lead wires, or loose lead connections. 3. Shorted, grounded or open magneto lighting coil. 	Replace. Repair, replace or retighten. Replace.
Magneto does not charge	<ol style="list-style-type: none"> 1. Open or short in lead wires, or loose lead connections. 2. Shorted, grounded or open magneto coils. 3. Shorted or punctured regulator/rectifier. 	Repair, replace or retighten. Replace. Replace.
Magneto charges, but charging rate is below the specification.	<ol style="list-style-type: none"> 1. Lead wires tend to get shorted or open-circuited or loosely connected at terminals. 2. Grounded or open-circuited stator coils of magneto. 3. Defective regulator/rectifier. 4. Not enough electrolyte in the battery. 5. Defective cell plates in the battery. 	Repair or retighten. Replace. Replace. Add distilled water to the upper level. Replace the battery.
Magneto overcharges	<ol style="list-style-type: none"> 1. Internal short-circuit in the battery. 2. Resistor element in the regulator/rectifier damaged or defective. 3. Regulator/rectifier poorly grounded. 	Replace the battery. Replace. Clean and tighten ground connection.
Unstable charging	<ol style="list-style-type: none"> 1. Lead wire insulation frayed due to vibration, resulting in intermittent shorting. 2. Generator internally shorted. 3. Defective regulator/rectifier. 	Replace. Replace. Replace.
Starter button is not effective.	<ol style="list-style-type: none"> 1. Battery run down. 2. Defective switch contacts. 3. Brushes not seating properly on commutator in starter motor. 4. Defective starter relay. 5. Wiring connections loose or disconnected. 	Recharge or replace. Replace. Repair or replace. Replace. Connect, tighten or repair.

7-5 SERVICING INFORMATION

Complaint	Symptom and possible causes	Remedy
<p>Battery "sulfation" ("Sulfation", acidic white powdery substance or spots on surfaces of cell plates.)</p>	<ol style="list-style-type: none"> 1. Charging rate too low or too high. (When not in use battery should be recharged at least once a month to avoid sulfation.) 2. Battery electrolyte excessive or insufficient, or its specific gravity too high or too low. 3. The battery left unused in a run-down condition for too long in cold climate. 4. Contaminated electrolyte. (Foreign matter has entered, mixed with the electrolyte, and contaminated it.) 	<p>Replace the battery.</p> <p>Keep the electrolyte up to the prescribed level, or adjust the S.G. by consulting the battery maker's directions.</p> <p>Replace the battery, if badly sulfated.</p> <p>If "sulfation" has not advanced too far, try to restore the battery by replacing the electrolyte, recharging it fully with the battery detached from the vehicle and then adjusting electrolyte's S.G.</p>
<p>Battery discharges too rapidly</p>	<ol style="list-style-type: none"> 1. Dirty container. 2. Impurities in the electrolyte or electrolyte S.G. is too high. 3. The charging system is not set for proper charging operation. 4. Cell plates have lost much of their active material as a result of overcharging. 5. A short-circuit condition exists within the battery due to an excessive accumulation of sediments caused by the electrolyte's high S.G. 6. Electrolyte's S.G. is too low. 7. Contaminated electrolyte. 	<p>Clean.</p> <p>Change the electrolyte by consulting the battery maker's directions.</p> <p>Check the generator, regulator/rectifier and circuit connections, and make necessary adjustments for specified charging operation.</p> <p>Replace the battery, and correct the charging system.</p> <p>Replace the battery.</p> <p>Recharge the battery fully and adjust electrolyte's S.G.</p> <p>Replace the electrolyte, recharge the battery and then adjust S.G. or replace the battery.</p>
<p>Reversed battery polarity</p>	<p>The battery has been connected the other way around in the system, so that it is being charged in the reverse direction.</p>	<p>Replace the battery and be sure to connect the battery properly.</p>

CHASSIS

Complaint	Symptom and possible causes	Remedy
Handling feels too heavy or stiff	<ol style="list-style-type: none"> 1. Disturbed front wheel alignment. 2. Poorly lubricated. 3. Not enough pressure in tires. 4. Tie-rod ends tending to seize. 5. Linkage connections tending to seize. 	Adjust. Lubricate. Adjust. Replace. Repair or replace.
Steering oscillation	<ol style="list-style-type: none"> 1. Wheel tires inflated unequally. 2. Wobbly wheels. 3. Loose nut on wheel hub. 4. Damaged or worn wheel hub bearing. 5. Worn or loose tie-rod ends. 6. Defective or incorrect tires. 7. Damaged wishbone arm bushing. 8. Loosen bolts and nuts on chassis. 	Adjust tire pressure. Replace. Retighten. Replace. Replace or retighten. Replace. Replace. Retighten.
Steering pulling to one side	<ol style="list-style-type: none"> 1. Wheel tires unequally inflated. 2. Disturbed front wheel alignment. 3. Worn or broken wheel hub bearing. 4. Distorted frame. 5. Defective shock absorber. 	Adjust tire pressure. Adjust. Replace. Repair or replace. Replace.
Shocks coming to steering	<ol style="list-style-type: none"> 1. Tire inflating pressure too high. 2. Worn steering linkage connections. 3. Loose bolts on suspension system. 	Adjust. Replace. Retighten.
Rapid wear or uneven wear of tires	<ol style="list-style-type: none"> 1. Worn or loosen wheel hub bearing. 2. Disturbed front wheel alignment. 	Replace. Adjust.
Steering noise	<ol style="list-style-type: none"> 1. Loose bolt and nut. 2. Broken or otherwise damaged wheel hub bearing. 3. Poorly lubricated. 	Retighten. Replace. Lubricate.
Front suspension too soft	<ol style="list-style-type: none"> 1. Weakened spring. 2. Oil leakage of shock absorber. 	Replace. Replace.
Front suspension too shift	<ol style="list-style-type: none"> 1. Worn wishbone arm related bushing. 	Replace.
Noisy suspension	<ol style="list-style-type: none"> 1. Loose bolt on suspension system. 2. Worn wishbone arm related bushing. 	Retighten. Replace.
Rear wheel oscillation	<ol style="list-style-type: none"> 1. Worn or loose rear axle housing bearing. 2. Defective or incorrect tire. 3. Distorted wheel rim. 4. Loose nut on wheel hub. 5. Loose nut on axle shaft. 	Replace. Replace. Replace. Retighten. Retighten.
Rear suspension too soft	<ol style="list-style-type: none"> 1. Weakened spring. 2. Rear shock absorber spring improperly set. 3. Oil leakage of rear shock absorber. 	Replace. Reset. Replace.
Rear suspension too stiff	<ol style="list-style-type: none"> 1. Rear shock absorber spring improperly set. 2. Shock absorber shaft bent. 3. Swingarm bent. 4. Worn swingarm related bearing. 	Adjust. Replace. Replace. Replace.

7-7 SERVICING INFORMATION

Complaint	Symptom and possible causes	Remedy
Poor braking	<ol style="list-style-type: none"><li data-bbox="440 205 675 233">1. Lining worn down.<li data-bbox="440 233 906 260">2. Too much play on brake lever and pedal.	Replace. Adjust.

WIRING DIAGRAM

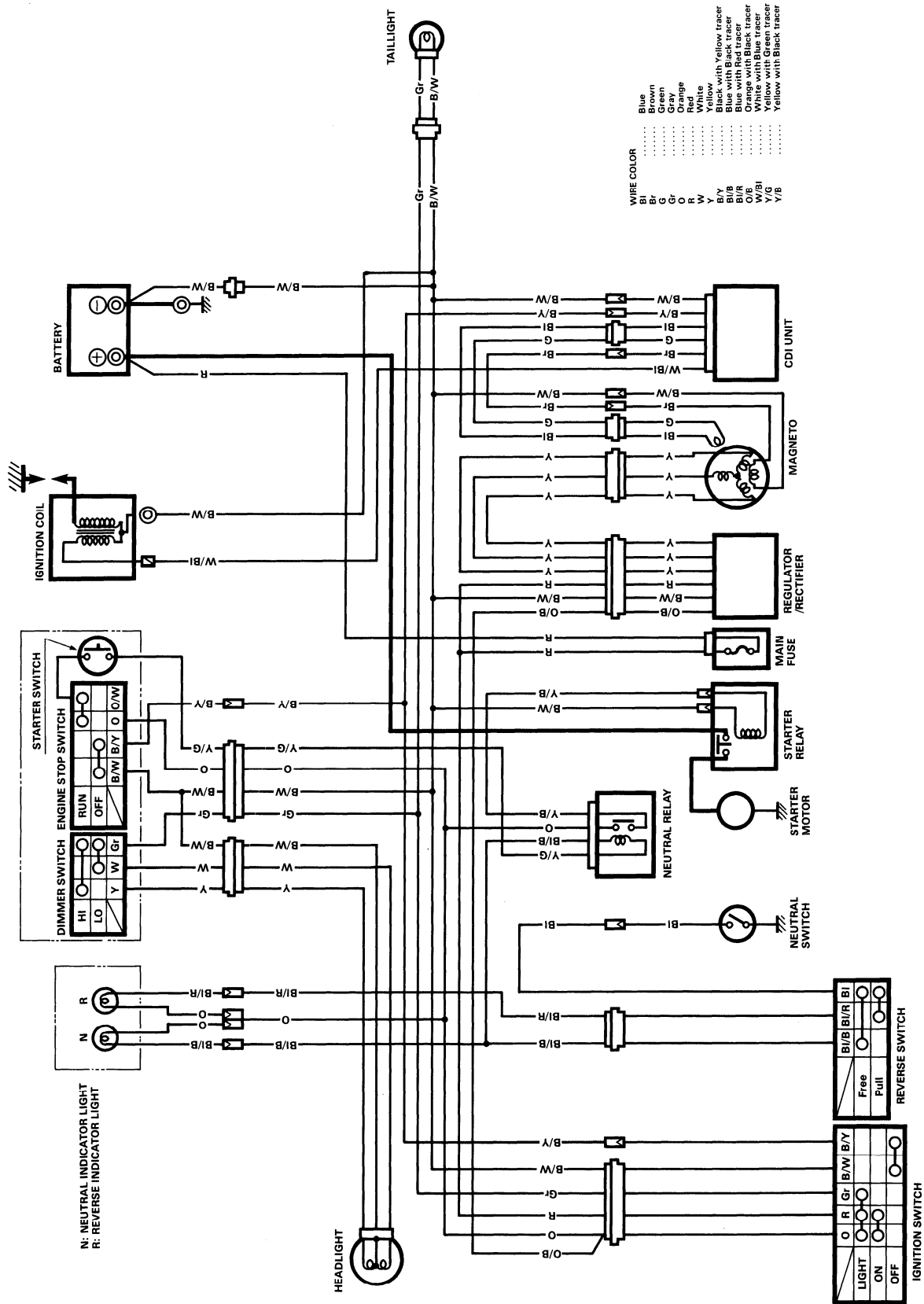



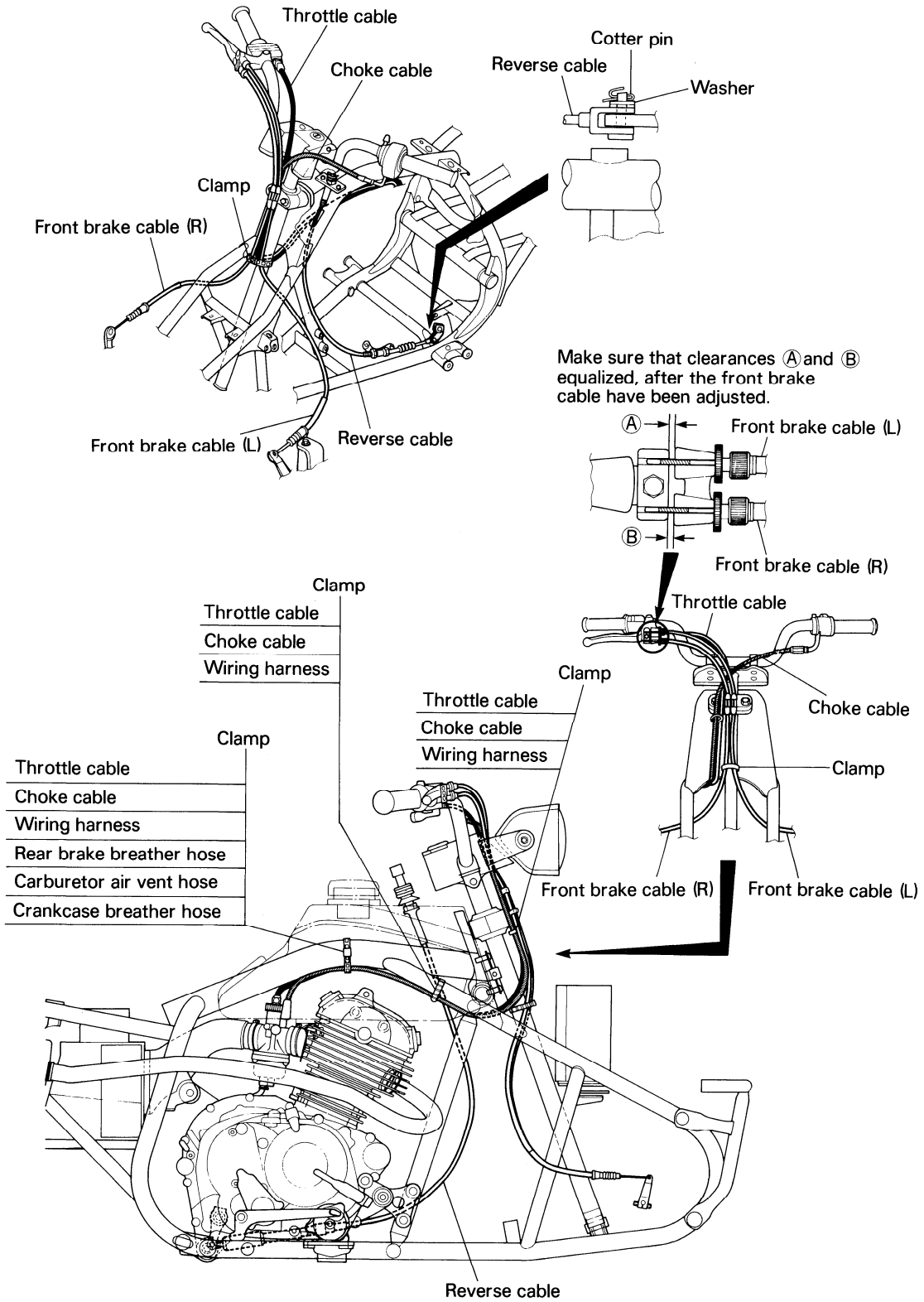



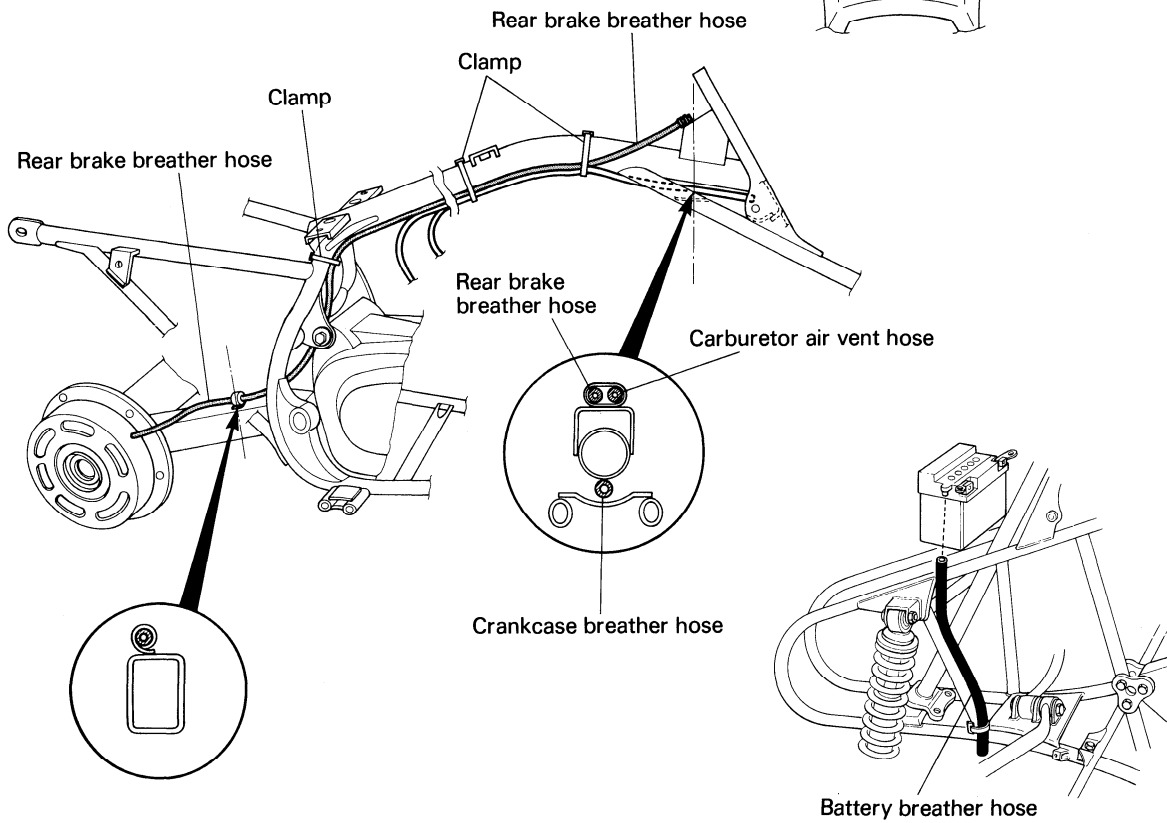
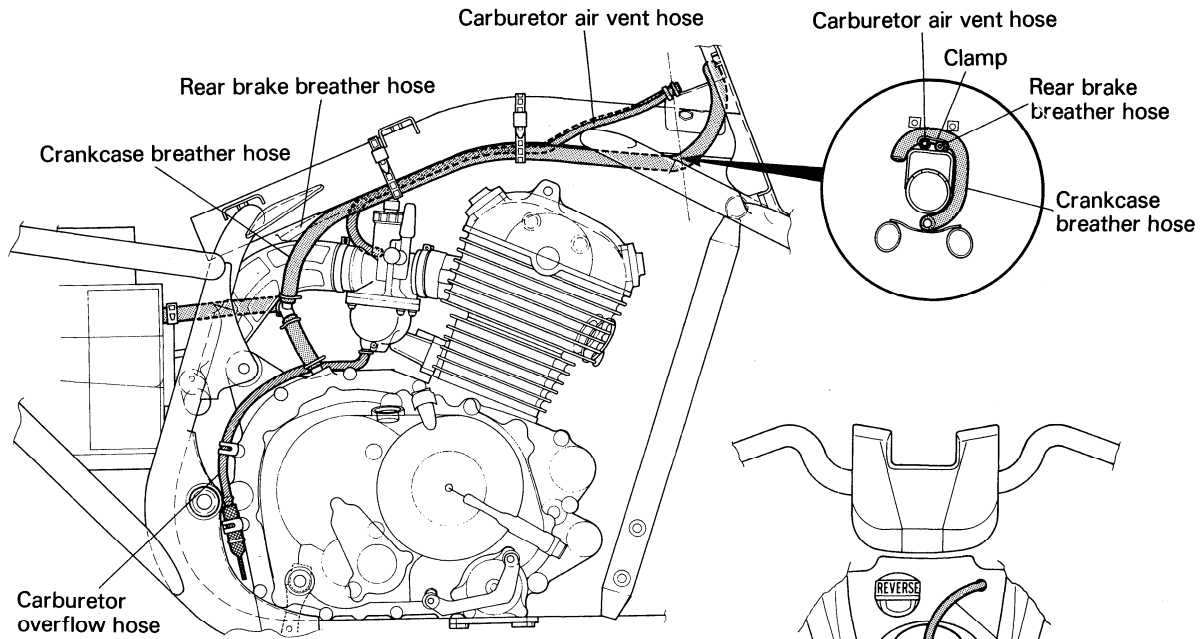

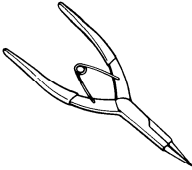
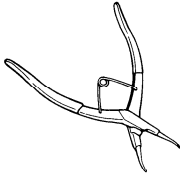
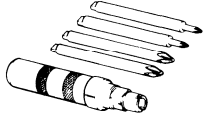
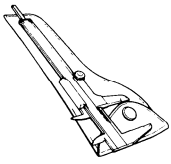
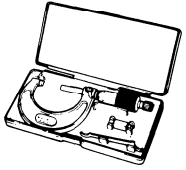

CABLE ROUTING



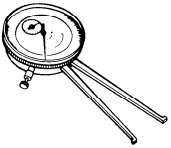

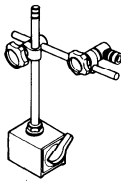
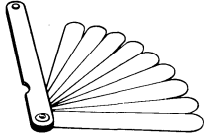
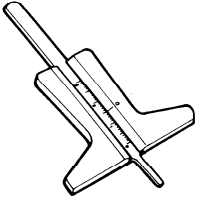
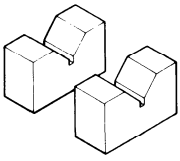

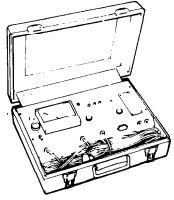
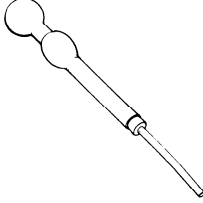
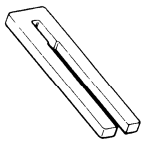
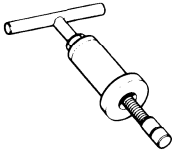

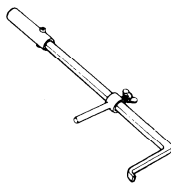
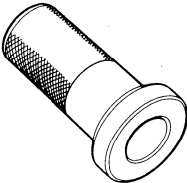
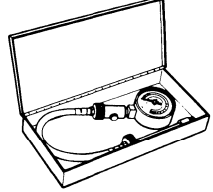
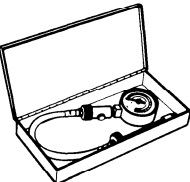
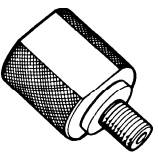
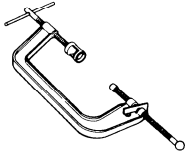
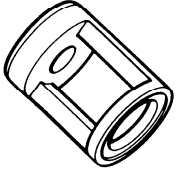
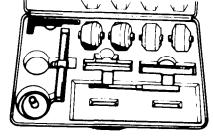
HOSE ROUTING

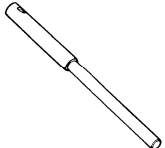
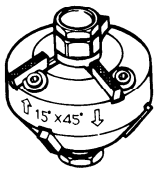

SPECIAL TOOLS

 <p>09900-06107 Snap ring pliers</p>	 <p>09900-06108 Snap ring pliers</p>	 <p>09900-09003 Impact driver set</p>	 <p>09900-20101 Vernier calipers</p>	 <p>09900-20202 Micrometer (25 – 50 mm)</p>
 <p>09900-20203 Micrometer (50 – 75 mm)</p>	 <p>09900-20205 Micrometer (0 – 25 mm)</p>	 <p>09900-20508 Cylinder gauge set</p>	<p>*</p>  <p>09900-20605 Dial calipers</p>	 <p>09900-20606 Dial gauge (1/100 mm)</p>
<p>*</p>  <p>09900-20701 Magnetic stand</p>	 <p>09900-20803 Thickness gauge</p>	<p>*</p>  <p>09900-20805 Tire depth gauge</p>	<p>*</p>  <p>09900-21304 V-block (100 mm)</p>	<p>*</p>  <p>09900-22301 Plastigauge</p>
 <p>09900-25002 Pocket tester</p>	<p>*</p>  <p>09900-26005 Engine tachometer</p>	 <p>09900-28106 Electro tester</p>	 <p>09900-28403 Hydrometer</p>	 <p>09910-20115 Conrod holder</p>
 <p>09910-32812 Crankshaft installer</p>	 <p>09910-34510 Piston pin puller</p>	 <p>09913-50121 Oil seal remover</p>	 <p>09913-85210 Bearing installer</p>	 <p>09915-64510 Compression gauge</p>
 <p>09915-74510 Oil pressure gauge</p>	 <p>09915-74531 Oil pressure gauge adapter</p>	 <p>09916-14510 Valve spring compressor</p>	 <p>09916-14910 Valve spring compressor attachment</p>	<p>*</p>  <p>09916-21110 Valve seat cutter set</p>

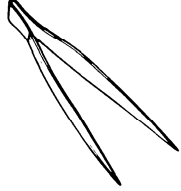
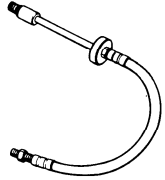
7-13 SERVICING INFORMATION

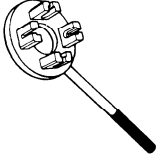
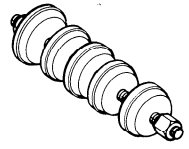
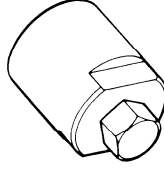
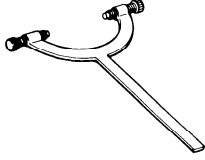
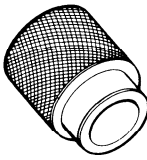
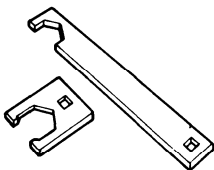
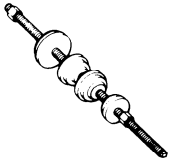
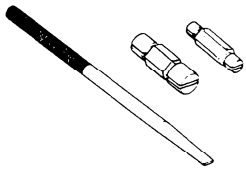
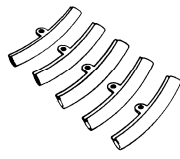
<p>*</p>  <p>09916-24450 Solid pilot N-100-10</p>	<p>*</p>  <p>09916-24420 Valve seat cutter head (N-116)</p>	 <p>09916-34542 Reamer handle</p>	 <p>09916-34550 5.5 mm reamer</p>	 <p>09916-34561 11.3 mm reamer</p>
 <p>09916-44910 Valve guide installer and remover</p>	 <p>09916-84510 Tweezers</p>	 <p>09918-02410 Compression pressure gauge adapter</p>	 <p>09920-13120 Crankcase separating tool/crankshaft remover</p>	 <p>09920-53730 Clutch sleeve hub holder</p>
 <p>09924-84510 Bearing installer set</p>	 <p>09930-34932 Rotor remover set</p>	 <p>09930-44913 Rotor remover holder</p>	 <p>09940-53111 Bearing installer</p>	 <p>09940-92410 Rear axle nut wrench (41 mm)</p>
 <p>09941-34513 Bearing installer</p>	<p>*</p>  <p>09941-50110 Bearing remover</p>	 <p>09941-94510 Rim protector</p>		

*: Not available in U.S.A.

TIGHTENING TORQUE

ENGINE

ITEM	N·m	kg-m	lb-ft
Cylinder head cover bolt	9 – 11	0.9 – 1.1	6.5 – 8.0
Cylinder head nut	21 – 25	2.1 – 2.5	15.0 – 18.0
Rocker arm shaft bolt	8 – 10	0.8 – 1.0	6.0 – 7.0
Cylinder base nut	7 – 11	0.7 – 1.1	5.0 – 8.0
Camshaft sprocket bolt	10 – 12	1.0 – 1.2	7.0 – 8.5
Cam chain tensioner bolt	6 – 8	0.6 – 0.8	4.5 – 6.0
Magneto rotor nut	145 – 175	14.5 – 17.5	105.0 – 126.5
Clutch sleeve hub nut	60 – 80	6.0 – 8.0	43.5 – 58.0
Clutch shoe nut	110 – 130	11.0 – 13.0	79.5 – 94.0
Starter clutch Allen bolt	23 – 28	2.3 – 2.8	16.5 – 20.0
Clutch release outer nut	10 – 12	1.0 – 1.2	7.0 – 8.5
T.D.C. plug	20 – 25	2.0 – 2.5	14.5 – 18.0
Oil pressure checking bolt	8 – 12	0.8 – 1.2	6.0 – 8.5
Oil pump screw	5 – 8	0.5 – 0.8	3.5 – 6.0
Engine oil drain plug	20 – 25	2.0 – 2.5	14.5 – 18.0
Engine mounting nut	60 – 72	6.0 – 7.2	43.5 – 52.0
Engine sprocket nut	80 – 100	8.0 – 10.0	58.0 – 72.5
Exhaust pipe nut	9 – 12	0.9 – 1.2	6.5 – 8.5
Muffler mounting bolt	18 – 28	1.8 – 2.8	13.0 – 20.0
Gearshift arm stopper bolt	15 – 23	1.5 – 2.3	11.0 – 16.5
Gearshift lever bolt	8 – 12	0.8 – 1.2	6.0 – 8.5
Reverse shift cam stopper bolt	18 – 28	1.8 – 2.8	13.0 – 20.0
Reverse switch	20 – 25	2.0 – 2.5	14.5 – 18.0
Drive shaft oil seal retainer bolt	20 – 28	2.0 – 2.8	14.5 – 20.0

CHASSIS

ITEM	N·m	kg-m	lb-ft
Handlebar clamp bolt	18 – 28	1.8 – 1.8	13.0 – 20.0
Steering shaft holder bolt	18 – 28	1.8 – 2.8	13.0 – 20.0
Steering shaft lower nut	22 – 35	2.2 – 3.5	16.0 – 25.5
Knuckle arm nut	40 – 60	4.0 – 6.0	29.0 – 43.5
Tie-rod end nut	22 – 35	2.2 – 3.5	16.0 – 25.5
Tie-rod lock nut	22 – 35	2.2 – 3.5	16.0 – 25.5
Front shock absorber nut (Upper & Lower)	40 – 60	4.0 – 6.0	29.0 – 43.5
Front wheel hub nut	50 – 80	5.0 – 8.0	36.0 – 58.0
Front wheel set nut	20 – 31	2.0 – 3.1	14.5 – 22.5
Footrest bolt	55 – 77	5.5 – 7.7	40.0 – 55.5
Front brake plate bolt	8 – 12	0.8 – 1.2	6.0 – 8.5
Front brake cam lever nut	9 – 13	0.9 – 1.3	6.5 – 9.5
Headlight housing bracket bolt	18 – 28	1.8 – 2.8	13.0 – 20.0
Front suspension arm nut	55 – 77	5.5 – 7.7	40.0 – 55.5
Footrest right guard mounting nut	9 – 13	0.9 – 1.3	6.5 – 9.5
Rear wheel hub nut	85 – 115	8.5 – 11.5	61.5 – 83.0
Rear wheel set nut	44 – 66	4.4 – 6.6	32.0 – 47.5
Rear swingarm pivot shaft nut	50 – 80	5.0 – 8.0	36.0 – 58.0
Rear shock absorber nut (Upper & Lower)	40 – 60	4.0 – 6.0	29.0 – 43.5
Rear brake pedal bolt	20 – 31	2.0 – 3.1	14.5 – 22.5
Rear axle nut and lock nut	160 – 200	16.0 – 20.0	115.5 – 144.5
Rear axle housing mounting bolt and nut	70 – 100	7.0 – 10.0	50.5 – 72.5
Rear sprocket and brake guard mounting bolt	20 – 31	2.0 – 3.1	14.5 – 22.5
Rear brake drum cover bolt	5 – 8	0.5 – 0.8	3.5 – 6.0
Rear brake cam lever nut	9 – 13	0.9 – 1.3	6.5 – 9.5
Rear brake drain bolt	5 – 8	0.5 – 0.8	3.5 – 6.0
Rear sprocket nut	48 – 72	4.8 – 7.2	34.5 – 52.0
Chain adjuster lock nut	18 – 28	1.8 – 2.8	13.0 – 20.0

TIGHTENING TORQUE CHART

For other bolts and nuts not listed in the preceding page, refer to this chart.

Bolt Diameter Ⓐ (mm)	Conventional or "4" marked bolt			"7" marked bolt		
	N·m	kg·m	lb·ft	N·m	kg·m	lb·ft
4	1 – 2	0.1 – 0.2	0.7 – 1.5	1.5 – 3	0.15 – 0.3	1.0 – 2.0
5	2 – 4	0.2 – 0.4	1.5 – 3.0	3 – 6	0.3 – 0.6	2.0 – 4.5
6	4 – 7	0.4 – 0.7	3.0 – 5.0	8 – 12	0.8 – 1.2	6.0 – 8.5
8	10 – 16	1.0 – 1.6	7.0 – 11.5	18 – 28	1.8 – 2.8	13.0 – 20.0
10	22 – 35	2.2 – 3.5	16.0 – 25.5	40 – 60	4.0 – 6.0	29.0 – 43.5
12	35 – 55	3.5 – 5.5	25.5 – 40.0	70 – 100	7.0 – 10.0	50.5 – 72.5
14	50 – 80	5.0 – 8.0	36.0 – 58.0	110 – 160	11.0 – 16.0	79.5 – 115.5
16	80 – 130	8.0 – 13.0	58.0 – 94.0	170 – 250	17.0 – 25.0	123.0 – 181.0
18	130 – 190	13.0 – 19.0	94.0 – 137.5	200 – 280	20.0 – 28.0	144.5 – 202.5

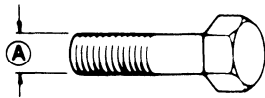

Conventional bolt

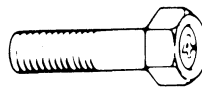

"4" marked bolt

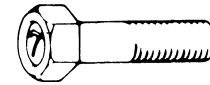

"7" marked bolt

SERVICE DATA

VALVE + GUIDE

Unit: mm (in)

ITEM	STANDARD		LIMIT
Valve diam.	IN.	28 (1.1)	——
	EX.	25 (1.0)	——
Valve lift	IN.	7.5 (0.30)	——
	EX.	7.0 (0.28)	——
Valve clearance (when cold)	IN.	0.03 – 0.08 (0.001 – 0.003)	——
	EX.	0.05 – 0.10 (0.002 – 0.004)	——
Valve guide to valve stem clearance	IN.	0.010 – 0.037 (0.0004 – 0.0015)	0.35 (0.014)
	EX.	0.030 – 0.057 (0.0012 – 0.0022)	0.35 (0.014)
Valve guide I.D.	IN. & EX.	5.500 – 5.512 (0.2165 – 0.2170)	——
Valve stem O.D.	IN.	5.475 – 5.490 (0.2155 – 0.2161)	——
	EX.	5.455 – 5.470 (0.2148 – 0.2153)	——
Valve stem runout	IN. & EX.	——	0.05 (0.002)
Valve head thickness	IN. & EX.	——	0.5 (0.02)
Valve stem end length	IN. & EX.	——	2.5 (0.10)
Valve seat width	IN. & EX.	0.9 – 1.1 (0.035 – 0.043)	——
Valve head radial runout	IN. & EX.	——	0.03 (0.001)
Valve spring free length (IN. & EX.)	——		39.5 (1.56)
Valve spring tension (IN. & EX.)	18.4 – 21.6 kg (40.6 – 47.6 lbs) at length 36.8 mm (1.45)		——

CAMSHAFT + CYLINDER HEAD

Unit: mm (in)

ITEM	STANDARD		LIMIT
Cam height	IN.	33.768 – 33.808 (1.3294 – 1.3310)	33.470 (1.3177)
	EX.	33.390 – 33.430 (1.3146 – 1.3161)	33.090 (1.3028)
Camshaft journal oil clearance	IN. & EX.	0.032 – 0.066 (0.0013 – 0.0026)	0.150 (0.0059)

ITEM	STANDARD		LIMIT
Camshaft journal holder I.D.	IN. & EX.	22.012 – 22.025 (0.8666 – 0.8671)	—
Camshaft journal O.D.	IN. & EX.	21.959 – 21.980 (0.8645 – 0.8654)	—
Camshaft runout	IN. & EX.	—	0.10 (0.004)
Cam chain 20-pitch length	—		129.0 (5.08)
Rocker arm I.D.	IN. & EX.	12.000 – 12.018 (0.4724 – 0.4731)	—
Rocker arm shaft O.D.	IN. & EX.	11.977 – 11.995 (0.4715 – 0.4722)	—
Cylinder head distortion	—		0.05 (0.002)
Cylinder head cover distortion	—		0.05 (0.002)

CYLINDER + PISTON + PISTON RING

Unit: mm (in)

ITEM	STANDARD		LIMIT
Compression pressure	1 000 – 1 400 kPa (10 – 14 kg/cm ²) (142 – 199 psi)		800 kPa (8 kg/cm ²) (114 psi)
Piston to cylinder clearance	0.030 – 0.040 (0.0012 – 0.0016)		0.120 (0.0047)
Cylinder bore	58.000 – 58.015 (2.2835 – 2.2841)		58.100 (2.2874)
Piston diam.	57.965 – 57.980 (2.2821 – 2.2827) Measure at 20 mm (0.79) from the skirt end.		57.880 (2.2787)
Cylinder distortion	—		0.05 (0.002)
Piston ring free end gap	1st	R Approx. 5.8 (0.23)	4.7 (0.19)
	2nd	R Approx. 7.4 (0.29)	6.0 (0.24)
Piston ring end gap	1st & 2nd	0.010 – 0.025 (0.004 – 0.010)	0.70 (0.028)
Piston ring to groove clearance	1st	—	0.180 (0.0071)
	2nd	—	0.150 (0.0059)
Piston ring groove width	1st & 2nd	1.21 – 1.23 (0.0476 – 0.0484)	—
	Oil	2.51 – 2.53 (0.0988 – 0.0996)	—
Piston ring thickness	1st & 2st	1.17 – 1.19 (0.046 – 0.047)	—
Piston pin bore	14.002 – 14.008 (0.5513 – 0.5515)		14.030 (0.5524)
Piston pin O.D.	13.996 – 14.000 (0.5510 – 0.5512)		13.980 (0.5504)

CONROD + CRANKSHAFT

Unit: mm (in)

ITEM	STANDARD	LIMIT
Conrod small end I.D.	14.004 – 14.012 (0.5513 – 0.5517)	14.040 (0.5528)
Conrod deflection	—	3.0 (0.12)
Conrod big end side clearance	0.10 – 0.45 (0.0039 – 0.0177)	1.00 (0.039)
Conrod big end width	15.95 – 16.00 (0.628 – 0.630)	—
Crank web to web width	53.0 ± 0.1 (2.087 ± 0.004)	—
Crankshaft runout	—	0.05 (0.002)

OIL PUMP

ITEM	STANDARD	LIMIT
Oil pump reduction ratio	1.566 (47/30)	—
Oil pressure (at 60°C, 140°F)	Above 30 kPa (0.30 kg/cm ² , 4.3 psi) Below 70 kPa (0.70 kg/cm ² 10.0 psi) at 3 000 r/min.	—

CLUTCH

Unit: mm (in)

ITEM	STANDARD	LIMIT
Clutch release screw	1/8 turn back	—
Drive plate thickness	2.7 – 2.9 (0.106 – 0.114)	2.4 (0.094)
Drive plate claw width	11.8 – 12.0 (0.46 – 0.47)	11.0 (0.43)
Driven plate distortion	—	0.10 (0.004)
Clutch spring free length	—	27.6 (1.09)
Clutch wheel I.D. (Clutch sleeve hub I.D.)	116 ± $\begin{smallmatrix} 0.15 \\ 0 \end{smallmatrix}$ (4.566 ± $\begin{smallmatrix} 0.006 \\ 0 \end{smallmatrix}$)	Scuffing or scratch on con- tacting surface
Clutch shoe	—	No groove at any part
Clutch engagement r/min.	2 200 ± 200 r/min.	—
Clutch lock-up r/min.	3 500 ± 250 r/min.	—

TRANSMISSION + DRIVE CHAIN

Unit: mm (in) Except ratio

ITEM	STANDARD	LIMIT
Primary reduction ratio	3.736 (71/19)	—
Final reduction ratio	3.545 (39/11)	—
Gear ratios	Low	3.166 (38/12)
	2nd	2.142 (30/14)
	3rd	1.588 (27/17)
	4th	1.200 (24/20)
	Top	0.950 (19/20)
	Reverse	2.833 (29/12 × 34/29)

ITEM	STANDARD		LIMIT
Shift fork to groove clearance	0.10 – 0.30 (0.004 – 0.012))		0.50 (0.020)
Shift fork to groove width	No.1,No.2 & No.3	4.50 – 4.60 (0.177 – 0.181)	—
	Reverse	4.00 – 4.10 (0.157 – 0.161)	—
Shift fork thickness	No.1,No.2 & No.3	4.30 – 4.40 (0.169 – 0.173)	—
	Reverse	3.80 – 3.90 (0.150 – 0.154)	—
Drive chain	Type	D.I.D.: DID520V TAKASAGO: RK520SM	—
	Links	84	—
	20-pitch length	—	319.4 (12.57)
Drive chain slack	20 – 30 (0.8 – 1.2)		—
Gearshift lever height	10 (0.4)		—

CARBURETOR

ITEM	SPECIFICATION	
Carburetor type	MIKUNI VM20SS	
Bore size	20 mm	
I.D. No.	02C00	02C01
Idle r/min.	1 500 ± 50 r/min.	
Float height	25.8 ± 1.0 mm (1.02 ± 0.04 in)	
Main jet (M.J.)	# 82.5	# 90
Main air jet (M.A.J.)	1.0 mm	
Jet needle (J.N.)	5FU96-3rd	
Needle jet (N.J.)	O-1	
Cut-away (C.A.)	2.5	
Pilot jet (P.J.)	# 17.5	# 20
By-pass (B.P.)	1.2 mm	
Pilot outlet (P.O.)	0.7 mm	
Valve seat (V.S.)	1.5 mm	
Starter jet (G.S.)	# 22.5	
Pilot screw (P.S.)	2.0 turns back	
Pilot air jet (P.A.J.)	1.3 mm	
Throttle cable play	0.5 – 1.0 mm (0.02 – 0.04 in)	
Choke cable play	0.5 – 1.0 mm (0.02 – 0.04 in)	

ELECTRICAL

Unit: mm (in)

ITEM		SPECIFICATION		NOTE
Ignition timing		10° B.T.D.C. below 1 000 r/min. and 30° B.T.D.C. above 5 000 r/min.		
Spark plug	Type	NGK: D7EA CHAMPION: A8YC		For U.K. and U.S.A.
	Gap	0.6 – 0.7 (0.024 – 0.028)		
	Type	NGK: DR7EA CHAMPION: RA8YC		For the others
	Gap	0.6 – 0.7 (0.024 – 0.028)		
Spark performance		Over 8 (0.3) at 1 atm.		
Ignition coil resistance	Primary	0.1 – 1.0 Ω		Terminal – Ground
	Secondary	10 – 25 kΩ		Plug cap – Ground
Magneto coil resistance	Primary	350 – 550 Ω		Br – B/W
	Pulser	200 – 400 Ω		Bl – G
	Charging	0.6 – 1.0 Ω		Y – Y
Generator no-load voltage		More than 55 V (AC) at 5 000 r/min.		
Regulated voltage		13.5 – 15.5 V at 5 000 r/min.		
Starter motor brush length	Limit:	9 (0.35)		MITSUBA
	commutator under-cut	Limit:	0.2 (0.008)	
Starter relay resistance		3 – 7 Ω		
Battery	Type designation	YB9A-A		
	Capacity	12 V 32.4 kC (9 Ah)/10 HR		
	Standard electrolyte S.G.	1.28 at 20°C (68°F)		
Fuse size		15 A		

WATTAGE

Unit: W

ITEM		SPECIFICATION
Headlight	HI	45
	LO	45
Taillight		5
Reverse indicator light		3.4
Neutral indicator light		3.4

BRAKE + WHEEL

Unit: mm (in)

ITEM	STANDARD		LIMIT
Front brake lever free travel	30 (1.2)		—
Rear brake pedal free travel	20–30 (0.8–1.2)		—
Brake drum I.D.	Front	—	120.7 (4.75)
	Rear	—	150.7 (5.93)
Brake lining thickness	—		1.5 (0.06)
Steering angle	Inside	41°	—
	Outside	30°	—
Turning radius	2.4 m (7.9 ft)		—
Toe-in (with 75 kg, 165 lbs)	3 – 11 (0.1 – 0.4)		—
Caster	8°		—
Trail	31 (1.2)		—
Wheel axle runout	Rear	—	8.0 (0.31)
Tire size	Front	AT20 × 7-8 ☆	—
	Rear	AT 22 × 10-8 ☆	—
Tire tread depth	Front	4.0 (0.16)	—
	Rear	4.0 (0.16)	—

SUSPENSION

Unit: mm (in)

ITEM	STANDARD	LIMIT	NOTE
Rear shock absorber spring setting	2nd position	—	
Front wheel travel	80 (3.1)	—	
Rear wheel travel	90 (3.5)	—	
Swingarm pivot shaft runout	—	0.6 (0.02)	

TIRE PRESSURE

COLD INFLATION TIRE PRESSURE	LOAD CAPACITY					
	UP TO 80 kg (175 lbs)			80–130 kg (175–285 lbs)		
	kPa	kg/cm ²	psi	kPa	kg/cm ²	psi
FRONT	17.5	0.175	2.5	25	0.25	3.6
REAR	15	0.15	2.2	20	0.20	2.9

FUEL + OIL

ITEM	SPECIFICATION		NOTE
Fuel type	Use only unleaded or low-lead type gasoline of at least 85-95 pump octane ($\frac{R+M}{2}$) or 89 octane or higher rated by the research method. Gasoline containing MTBE (Methyl Tertiary Butyl Ether), less than 10% ethanol, or less than 5% methanol with appropriate cosolvents and corrosion inhibitor is permissible.		For U.S.A.
	Use only unleaded or low-lead type gasoline of at least 85-95 pump octane ($\frac{R+M}{2}$ method) or 89 octane or higher rated by the Research Method.		For Canada
	Gasoline used should be graded 85-95 octane or higher. An unleaded or low-lead type gasoline is recommended.		For the others
Fuel tank including reserve	8.5 L (2.2/1.9 US/Imp gal)		
reserve	1.1 L (1.2/1.0 US/Imp qt)		
Engine oil type	SAE 10W/40, API SE or SF		
Engine oil capacity	Change	1 500 ml (1.6/1.3 US/Imp qt)	
	Filter change	1 700 ml (1.8/1.5 US/Imp qt)	
	Overhaul	1 900 ml (2.0/1.8 US/Imp qt)	

LT160EL ('90-MODEL)

This section describes up-to-date service procedures which differ from those of the LT160E models.

- *Any differences in service data and service specifications with those that apply to the LT160EL models are clearly indicated with an asterisk (*).*
- *Please refer to the sections 1 through 7 for details which are not given in this section.*

CONTENTS

SPECIFICATIONS	8- 1
SERVICE DATA	8- 2
HOSE ROUTING	8- 9

SPECIFICATIONS

DIMENSIONS AND DRY MASS

Overall length	1 605 mm (63.2 in)
Overall width	985 mm (38.8 in)
Overall height	1 000 mm (39.4 in)
Wheelbase	1 070 mm (42.1 in)
Ground clearance	135 mm (5.3 in)
Front track	730 mm (28.7 in)
Rear track	730 mm (28.7 in)
Seat height	725 mm (28.5 in)
Dry mass	152 kg (335 lbs)

ENGINE

Type	Four-stroke, air-cooled, OHC
Number of cylinders	1
Bore	58.0 mm (2.283 in)
Stroke	60.0 mm (2.362 in)
Piston displacement	158 cm ³ (9.6 cu. in)
Compression ratio	9.2 : 1
Carburetor	MIKUNI VM20SS
Air cleaner	Polyurethane foam element.
Starter system	Electric
Lubrication system	Wet sump

TRANSMISSION

Clutch	Wet multi-plate auto- matic, centrifugal type
Transmission	5-speed constant mesh, 1-reverse
Gearshift pattern,	
Forward	All-up, foot lever operated
Reverse	Hand lever operated
Primary reduction	3.736 (71/19)
Final reduction	3.545 (39/11)
Gear ratio, Low	3.166 (38/12)
2nd	2.142 (30/14)
3rd	1.588 (27/17)
4th	1.200 (24/20)
Top	0.950 (19/20)
Reverse	2.833 (34/12)
Drive chain	DAIDO D.I.D. 520VS or TAKASAGO RK520SM, 84 links

CHASSIS

Front suspension	Independent, swing axle, coil spring, oil damped
Rear suspension	Swingarm coil spring, oil damped, spring preload 5-way adjustable
Steering angle	41° (Inside) 30° (Outside)
Caster	8°
Trail	31 mm (1.2 in)
Toe-in	3–11 mm (0.1–0.4 in)
Turning radius	2.4 m (7.9 ft)
Front brake	Internal expanding
Rear brake	Internal expanding
Front tire size	AT 20 x 7-8 ☆
Rear tire size	AT 22 x 10-8 ☆
Front wheel travel	80 mm (3.1 in)
Rear wheel travel	90 mm (3.5 in)

ELECTRICAL

Ignition type	SUZUKI "PEI"
Ignition timing	10° B.T.D.C. below 1 000 r/min and 30° B.T.D.C. above 5 000 r/min
Spark plug	NGK *DP7EA-9 or N.D. *X22EP-U9 U.K. NGK *DPR7EA-9 or N.D. *X22EPR-U9 Others
Battery	12V 32.4 kC (9Ah)/10HR
Generator	Flywheel magneto
Fuse	15A

CAPACITIES

Fuel tank	
Including reserve	8.5 L (2.2/1.9 US/Imp gal)
reserve	1.1 L (0.3/0.2 US/Imp gal)
Engine oil,	
oil change	1 500 ml (1.6/1.3 US/Imp qt)
filter change	1 700 ml (1.8/1.5 US/Imp qt)

An asterisk mark (*) indicates the New "L" model specifications.

These specifications are subject to change without notice.

SERVICE DATA**VALVE + GUIDE**

Unit: mm (in)

ITEM	STANDARD		LIMIT
Valve diam.	IN.	28 (1.1)	—
	EX.	25 (1.0)	—
Valve lift	IN.	* 7.1 (0.28)	—
	EX.	* 6.9 (0.27)	—
Valve clearance (when cold)	IN.	0.03–0.08 (0.001–0.003)	—
	EX.	0.05–0.10 (0.002–0.004)	—
Valve guide to valve stem clearance	IN.	0.010–0.037 (0.0004–0.0015)	0.35 (0.014)
	EX.	0.030–0.057 (0.0012–0.0022)	0.35 (0.014)
Valve guide I.D.	IN. & EX.	5.500–5.512 (0.2165–0.2170)	—
Valve stem O.D.	IN.	5.475–5.490 (0.2155–0.2161)	—
	EX.	5.455–5.470 (0.2148–0.2153)	—
Valve stem runout	IN. & EX.	—	0.05 (0.002)
Valve head thickness	IN. & EX.	—	0.5 (0.02)
Valve stem end length	IN. & EX.	—	2.5 (0.10)
Valve seat width	IN. & EX.	0.9–1.1 (0.035–0.043)	—
Valve head radial runout	IN. & EX.	—	0.03 (0.001)
Valve spring free length (IN. & EX.)	—		39.5 (1.56)
Valve spring tension (IN. & EX.)	18.4–21.6 kg (40.6–47.6 lbs) at length 36.8 mm (1.45 in)		—

CAMSHAFT + CYLINDER HEAD

Unit: mm (in)

ITEM	STANDARD		LIMIT
Cam height	IN.	* 33.490–33.530 (1.3185–1.3201)	* 33.190 (1.3067)
	EX.	* 33.353–33.393 (1.3131–1.3147)	* 33.060 (1.3016)
Camshaft journal oil clearance	IN. & EX.	0.032–0.066 (0.0013–0.0026)	0.150 (0.0059)

An asterisk mark (*) indicates the New "L" model specifications.

ITEM	STANDARD		LIMIT
Camshaft journal holder I.D.	IN. & EX.	22.012 – 22.025 (0.8666 – 0.8671)	—
Camshaft journal O.D.	IN. & EX.	21.959 – 21.980 (0.8645 – 0.8654)	—
Camshaft runout	IN. & EX.	—	0.10 (0.004)
Cam chain 20-pitch length	—		129.0 (5.08)
Rocker arm I.D.	IN. & EX.	12.000 – 12.018 (0.4724 – 0.4731)	—
Rocker arm shaft O.D.	IN. & EX.	11.977 – 11.995 (0.4715 – 0.4722)	—
Cylinder head distortion	—		0.05 (0.002)
Cylinder head cover distortion	—		0.05 (0.002)

CYLINDER + PISTON + PISTON RING

Unit: mm (in)

ITEM	STANDARD		LIMIT	
Compression pressure	1 000 – 1 400 kPa (10 – 14 kg/cm ²) (142 – 199 psi)		800 kPa (8 kg/cm ²) (114 psi)	
Piston to cylinder clearance	0.030 – 0.040 (0.0012 – 0.0016)		0.120 (0.0047)	
Cylinder bore	58.000 – 58.015 (2.2835 – 2.2841)		58.100 (2.2874)	
Piston diam.	57.965 – 57.980 (2.2821 – 2.2827) Measure at 20 mm (0.79) from the skirt end.		57.880 (2.2787)	
Cylinder distortion	—		0.05 (0.002)	
Piston ring free end gap	1st	R	Approx. 5.8 (0.23)	4.7 (0.19)
	2nd	R	Approx. 7.4 (0.29)	6.0 (0.24)
Piston ring end gap	1st & 2nd	0.010 – 0.025 (0.004 – 0.010)	0.70 (0.028)	
Piston ring to groove clearance	1st	—	0.180 (0.0071)	
	2nd	—	0.150 (0.0059)	
Piston ring groove width	1st & 2nd	1.21 – 1.23 (0.0476 – 0.0484)	—	
	Oil	2.51 – 2.53 (0.0988 – 0.0996)	—	
Piston ring thickness	1st & 2nd	1.17 – 1.19 (0.046 – 0.047)	—	
Piston pin bore	14.002 – 14.008 (0.5513 – 0.5515)		14.030 (0.5524)	
Piston pin O.D.	13.996 – 14.000 (0.5510 – 0.5512)		13.980 (0.5504)	

CONROD + CRANKSHAFT

Unit: mm (in)

ITEM	STANDARD	LIMIT
Conrod small end I.D.	14.004–14.012 (0.5513–0.5517)	14.040 (0.5528)
Conrod deflection	—	3.0 (0.12)
Conrod big end side clearance	0.10–0.45 (0.0039–0.0177)	1.00 (0.039)
Conrod big end width	15.95–16.00 (0.628–0.630)	—
Crank web to web width	53.0 ± 0.1 (2.087 ± 0.004)	—
Crankshaft runout	—	0.05 (0.002)

OIL PUMP

ITEM	STANDARD	LIMIT
Oil pump reduction ratio	1.566 (47/30)	—
Oil pressure (at 60°C, 140°F)	Above 30 kPa (0.30 kg/cm ² , 4.3 psi) Below 70 kPa (0.70 kg/cm ² , 10.0 psi) at 3 000 r/min.	—

CLUTCH

Unit: mm (in)

ITEM	STANDARD	LIMIT
Clutch release screw	0–1/8 turn back	—
Drive plate thickness	2.7–2.9 (0.106–0.114)	2.4 (0.094)
Drive plate claw width	11.8–12.0 (0.46–0.47)	11.0 (0.43)
Driven plate distortion	—	0.10 (0.004)
Clutch spring free length	—	27.6 (1.09)
Clutch wheel I.D. (Clutch sleeve hub I.D.)	116 ± ^{0.15} ₀ (4.566 ± ^{0.006} ₀)	Scuffing or scratch on con- tacting surface
Clutch shoe	—	No groove at any part
Clutch engagement r/min.	2 200 ± 200 r/min.	—
Clutch lock-up r/min.	3 500 ± 250 r/min.	—

TRANSMISSION + DRIVE CHAIN

Unit: mm (in) Except ratio

ITEM	STANDARD	LIMIT
Primary reduction ratio	3.736 (71/19)	—
Final reduction ratio	3.545 (39/11)	—
Gear ratios	Low	3.166 (38/12)
	2nd	2.142 (30/14)
	3rd	1.588 (27/17)
	4th	1.200 (24/20)
	Top	0.950 (19/20)
	Reverse	2.833 (29/12 x 34/29)

ITEM	STANDARD		LIMIT
Shift fork to groove clearance	0.10–0.30 (0.004–0.012)		0.50 (0.020)
Shift fork to groove width	No.1,No.2 &No.3	4.50–4.60 (0.177–0.181)	—
	Reverse	4.00–4.10 (0.157–0.161)	—
Shift fork thickness	No.1,No.2 & No.3	4.30–4.40 (0.169–0.173)	—
	Reverse	3.80–3.90 (0.150–0.154)	—
Drive chain	Type	D.I.D.: DID520V TAKASAGO: RK520SM	—
	Links	84	—
	20-pitch length	—	319.4 (12.57)
Drive chain slack	20–30 (0.8–1.2)		—
Gearshift lever height	10 (0.4)		—

CARBURETOR

ITEM	SPECIFICATION
Carburetor type	MIKUNI VM20SS
Bore size	20 mm
I.D. No.	*O2C02
Idle r/min.	1 500 ± 50 r/min.
Float height	25.8 ± 1.0 mm (1.02 ± 0.04 in)
Main jet (M.J.)	*#87.5
Main air jet (M.A.J.)	1.0 mm
Jet needle (J.N.)	5FU96-3rd
Needle jet (N.J.)	O-1
Cut-away (C.A.)	2.5
Pilot jet (P.J.)	*#22.5
By-pass (B.P.)	1.2 mm
Pilot outlet (P.O.)	0.7 mm
Valve seat (V.S.)	1.5 mm
Starter jet (G.S.)	#22.5
Pilot screw (P.S.)	*1 5/8 turns back
Pilot air jet (P.A.J.)	#1.3 mm
Throttle cable play	0.5–1.0 mm (0.02–0.04 in)
Choke cable play	0.5–1.0 mm (0.02–0.04 in)

An asterisk mark (*) indicates the New "L" model specifications.

ELECTRICAL

Unit: mm (in)

ITEM		SPECIFICATION		NOTE
Ignition timing		10° B.T.D.C. below 1 000 r/min. and 30° B.T.D.C. above 5000 r/min.		
Spark plug	Type	* NGK: DP7EA-9 * N.D.: X22EP-U9		P-02
	Gap	0.6–0.7 (0.024–0.028)		
	Type	* NGK: DPR7EA-9 * N.D.: X22EPR-U9		P-01, 28
	Gap	0.6–0.7 (0.024–0.028)		
Spark performance		Over 8 (0.3) at 1 atm.		
Ignition coil resistance	Primary	0.1–1.0 Ω		Terminal– Ground
	Secondary	10–25 kΩ		Plug cap– Ground
Magneto coil resistance	Primary	350–550 Ω		Br–B/W
	Pulser	200–400 Ω		BI–G
	Charging	0.6–1.0 Ω		Y–Y
Generator no-load voltage		More than 55V (AC) at 5 000 r/min.		
Regulated voltage		13.5–15.5V at 5 000 r/min.		
Starter motor brush length	Limit:	9 (0.35)		MITSUBA
	commutator under-cut	Limit:	0.2 (0.008)	
Starter relay resistance		3–7 Ω		
Battery	Type designation	YB9A-A		
	Capacity	12V 32.4 kC (9 Ah)/10 HR		
	Standard electrolyte S.G.	1.28 at 20°C (68°F)		
Fuse size		15 A		

WATTAGE

Unit: W

ITEM		SPECIFICATION
Headlight	HI	45
	LO	45
Taillight		5
Reverse indicator light		3.4
Neutral indicator light		3.4

An asterisk mark (*) indicates the New "L" model specifications.

BRAKE + WHEEL

Unit: mm (in)

ITEM	STANDARD		LIMIT
Front brake lever free travel	30 (1.2)		—
Rear brake pedal free travel	20–30 (0.8–1.2)		—
Brake drum I.D.	Front	—	120.7 (4.75)
	Rear	—	150.7 (5.93)
Brake lining thickness	—		1.5 (0.06)
Steering angle	Inside	41°	—
	Outside	30°	—
Turning radius	2.4 m (7.9 ft)		—
Toe-in (with 75 kg, 165 lbs)	3–11 (0.1–0.4)		—
Caster	8°		—
Trail	31 (1.2)		—
Wheel axle runout	Rear	—	8.0 (0.31)
Tire size	Front	AT 20 x 7-8 ☆	—
	Rear	AT 22 x 10-8 ☆	—
Tire tread depth	Front	4.0 (0.16)	—
	Rear	4.0 (0.16)	—

SUSPENSION

Unit: mm (in)

ITEM	STANDARD	LIMIT	NOTE
Rear shock absorber spring setting	2nd position	—	
Front wheel travel	80 (3.1)	—	
Rear wheel travel	90 (3.5)	—	
Swingarm pivot shaft runout	—	0.6 (0.02)	

TIRE PRESSURE

COLD INFLATION TIRE PRESSURE	LOAD CAPACITY					
	UP TO 80kg (175 lbs)			80–130 kg (175–285 lbs)		
	kPa	kg/cm ²	psi	kPa	kg/cm ²	psi
FRONT	17.5	0.175	2.5	25	0.25	3.6
REAR	15	0.15	2.2	20	0.20	2.9

FUEL + OIL

ITEM	SPECIFICATION		NOTE
Fuel type	Use only unleaded gasoline of at least 87 pump octane ($\frac{R+M}{2}$ method) or 91 octane or higher rated by the Research Method.		E-28
	Gasoline used should be graded 85-95 octane or higher. An unleaded gasoline is recommended.		For the others
Fuel tank including reserve	8.5 L (2.2/1.9 US/Imp gal)		
reserve	1.1 L (0.3/0.2 US/Imp gal)		
Engine oil type	SAE 10W/40, API SE or SF		
Engine oil capacity	Change	1 500 ml (1.6/1.3 US/Imp qt)	
	Filter change	1 700 ml (1.8/1.5 US/Imp qt)	
	Overhaul	1 900 ml (2.0/1.8 US/Imp qt)	

HOSE ROUTING

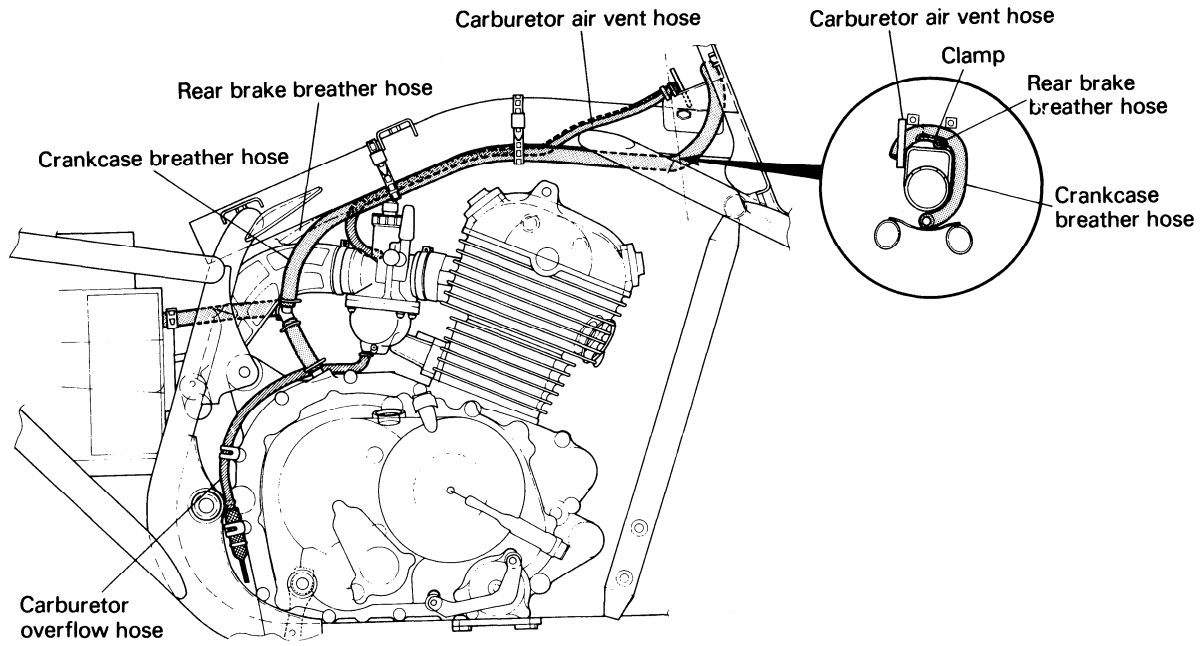

LT-F160L/M ('90,'91-MODELS)

This section describes service data, service specifications and servicing procedures which differ from those of the LT160EL ('90-model).

- *Any differences in service data and service specifications with those that apply to the LT-F160L/M models are clearly indicated with an asterisk (*).*
- *Please refer to the sections 1 through 7 for details which are not given in this section.*

CONTENTS

SPECIFICATIONS	9- 1
SERVICE DATA	9- 2
HOSE ROUTING	9- 9

SPECIFICATIONS

DIMENSIONS AND DRY MASS

Overall length	1 605 mm (63.2 in)
Overall width	985 mm (38.8 in)
Overall height	1 000 mm (39.4 in)
Wheelbase	1 070 mm (42.1 in)
Ground clearance	135 mm (5.3 in)
Front track	730 mm (28.7 in)
Rear track	730 mm (28.7 in)
Seat height	725 mm (28.5 in)
Dry mass	152 kg (335 lbs)

ENGINE

Type	Four-stroke, air-cooled, OHC
Number of cylinders	1
Bore	58.0 mm (2.283 in)
Stroke	60.0 mm (2.362 in)
Piston displacement	158 cm ³ (9.6 cu. in)
Compression ratio	9.2 : 1
Carburetor	MIKUNI VM20SS
Air cleaner	Polyurethane foam element
Starter system	Electric
Lubrication system	Wet sump

TRANSMISSION

Clutch	Wet multi-plate auto- matic, centrifugal type
Transmission	5-speed constant mesh, 1-reverse
Gearshift pattern,	
Forward	All-up, foot lever operated
Reverse	Hand lever operated
Primary reduction	3.736 (71/19)
Final reduction	3.545 (39/11)
Gear ratio, Low	3.166 (38/12)
2nd	2.142 (30/14)
3rd	1.588 (27/17)
4th	1.200 (24/20)
Top	0.950 (19/20)
Reverse	2.833 (34/12)
Drive chain	DAIDO D.I.D. 520VS or TAKASAGO RK520SM, 84 links

CHASSIS

Front suspension	Independent, swing axle, coil spring, oil damped
Rear suspension	Swingarm coil spring, oil damped, spring preload 5-way adjustable
Steering angle	41° (Inside) 30° (Outside)
Caster	8°
Trail	31 mm (1.2 in)
Toe-in	3–11 mm (0.1–0.4 in)
Turning radius	2.4 m (7.9 ft)
Front brake	Internal expanding
Rear brake	Internal expanding
Front tire size	AT 20 x 7-8 ☆
Rear tire size	AT 22 x 10-8 ☆
Front wheel travel	80 mm (3.1 in)
Rear wheel travel	90 mm (3.5 in)

ELECTRICAL

Ignition type	SUZUKI "PEI"
Ignition timing	10° B.T.D.C. below 1 000 r/min and 30° B.T.D.C. above 5 000 r/min
Spark plug	NGK *DP7EA-9 or N.D. *X22EP-U9 U.K. NGK *DPR7EA-9 or N.D. *X22EPR-U9 Others
Battery	12V 32.4 kC (9Ah)/10HR
Generator	Flywheel magneto
Fuse	15A

CAPACITIES

Fuel tank	
Including reserve	8.5 L (2.2/1.9 US/Imp gal)
reserve	1.1 L (0.3/0.2 US/Imp gal)
Engine oil,	
oil change	1 500 ml (1.6/1.3 US/Imp qt)
filter change	1 700 ml (1.8/1.5 US/Imp qt)

SERVICE DATA**VALVE + GUIDE**

Unit: mm (in)

ITEM	STANDARD		LIMIT
Valve diam.	IN.	28 (1.1)	—
	EX.	25 (1.0)	—
Valve lift	IN.	7.1 (0.28)	—
	EX.	6.9 (0.27)	—
Valve clearance (when cold)	IN.	0.03–0.08 (0.001–0.003)	—
	EX.	0.05–0.10 (0.002–0.004)	—
Valve guide to valve stem clearance	IN.	0.010–0.037 (0.0004–0.0015)	0.35 (0.014)
	EX.	0.030–0.057 (0.0012–0.0022)	0.35 (0.014)
Valve guide I.D.	IN. & EX.	5.500–5.512 (0.2165–0.2170)	—
Valve stem O.D.	IN.	5.475–5.490 (0.2155–0.2161)	—
	EX.	5.455–5.470 (0.2148–0.2153)	—
Valve stem runout	IN. & EX.	—	0.05 (0.002)
Valve head thickness	IN. & EX.	—	0.5 (0.02)
Valve stem end length	IN. & EX.	—	2.5 (0.10)
Valve seat width	IN. & EX.	0.9–1.1 (0.035–0.043)	—
Valve head radial runout	IN. & EX.	—	0.03 (0.001)
Valve spring free length (IN. & EX.)	—		39.5 (1.56)
Valve spring tension (IN. & EX.)	18.4–21.6 kg (40.6–47.6 lbs) at length 36.8 mm (1.45 in)		—

CAMSHAFT + CYLINDER HEAD

Unit: mm (in)

ITEM	STANDARD		LIMIT
Cam height	IN.	* 33.490–33.530 (1.3185–1.3201)	* 33.190 (1.3067)
	EX.	* 33.353–33.393 (1.3131–1.3147)	* 33.060 (1.3016)
Camshaft journal oil clearance	IN. & EX.	0.032–0.066 (0.0013–0.0026)	0.150 (0.0059)

ITEM	STANDARD		LIMIT
Camshaft journal holder I.D.	IN. & EX.	22.012 – 22.025 (0.8666 – 0.8671)	—
Camshaft journal O.D.	IN. & EX.	21.959 – 21.980 (0.8645 – 0.8654)	—
Camshaft runout	IN. & EX.	—	0.10 (0.004)
Cam chain 20-pitch length	—		129.0 (5.08)
Rocker arm I.D.	IN. & EX.	12.000 – 12.018 (0.4724 – 0.4731)	—
Rocker arm shaft O.D.	IN. & EX.	11.977 – 11.995 (0.4715 – 0.4722)	—
Cylinder head distortion	—		0.05 (0.002)
Cylinder head cover distortion	—		0.05 (0.002)

CYLINDER + PISTON + PISTON RING

Unit: mm (in)

ITEM	STANDARD		LIMIT
Compression pressure	1 000 – 1 400 kPa (10 – 14 kg/cm ²) (142 – 199 psi)		800 kPa (8 kg/cm ²) (114 psi)
Piston to cylinder clearance	0.030 – 0.040 (0.0012 – 0.0016)		0.120 (0.0047)
Cylinder bore	58.000 – 58.015 (2.2835 – 2.2841)		58.100 (2.2874)
Piston diam.	57.965 – 57.980 (2.2821 – 2.2827) Measure at 20 mm (0.79) from the skirt end.		57.880 (2.2787)
Cylinder distortion	—		0.05 (0.002)
Piston ring free end gap	1st	R Approx. 5.8 (0.23)	4.7 (0.19)
	2nd	R Approx. 7.4 (0.29)	6.0 (0.24)
Piston ring end gap	1st & 2nd	0.010 – 0.025 (0.004 – 0.010)	0.70 (0.028)
Piston ring to groove clearance	1st	—	0.180 (0.0071)
	2nd	—	0.150 (0.0059)
Piston ring groove width	1st & 2nd	1.21 – 1.23 (0.0476 – 0.0484)	—
	Oil	2.51 – 2.53 (0.0988 – 0.0996)	—
Piston ring thickness	1st & 2nd	1.17 – 1.19 (0.046 – 0.047)	—
Piston pin bore	14.002 – 14.008 (0.5513 – 0.5515)		14.030 (0.5524)
Piston pin O.D.	13.996 – 14.000 (0.5510 – 0.5512)		13.980 (0.5504)

CONROD + CRANKSHAFT

Unit: mm (in)

ITEM	STANDARD	LIMIT
Conrod small end I.D.	14.004 – 14.012 (0.5513 – 0.5517)	14.040 (0.5528)
Conrod deflection	—	3.0 (0.12)
Conrod big end side clearance	0.10 – 0.45 (0.0039 – 0.0177)	1.00 (0.039)
Conrod big end width	15.95 – 16.00 (0.628 – 0.630)	—
Crank web to web width	53.0 ± 0.1 (2.087 ± 0.004)	—
Crankshaft runout	—	0.05 (0.002)

OIL PUMP

ITEM	STANDARD	LIMIT
Oil pump reduction ratio	1.566 (47/30)	—
Oil pressure (at 60°C, 140°F)	Above 30 kPa (0.30 kg/cm ² , 4.3 psi) Below 70 kPa (0.70 kg/cm ² , 10.0 psi) at 3 000 r/min.	—

CLUTCH

Unit: mm (in)

ITEM	STANDARD	LIMIT
Clutch release screw	0 – 1/8 turn back	—
Drive plate thickness	2.7 – 2.9 (0.106 – 0.114)	2.4 (0.094)
Drive plate claw width	11.8 – 12.0 (0.46 – 0.47)	11.0 (0.43)
Driven plate distortion	—	0.10 (0.004)
Clutch spring free length	—	27.6 (1.09)
Clutch wheel I.D. (Clutch sleeve hub I.D.)	116 ± $\begin{matrix} 0.15 \\ 0 \end{matrix}$ (4.566 ± $\begin{matrix} 0.006 \\ 0 \end{matrix}$)	Scuffing or scratch on con- tacting surface
Clutch shoe	—	No groove at any part
Clutch engagement r/min.	2 200 ± 200 r/min.	—
Clutch lock-up r/min.	3 500 ± 250 r/min.	—

TRANSMISSION + DRIVE CHAIN

Unit: mm (in) Except ratio

ITEM	STANDARD	LIMIT
Primary reduction ratio	3.736 (71/19)	—
Final reduction ratio	3.545 (39/11)	—
Gear ratios	Low	3.166 (38/12)
	2nd	2.142 (30/14)
	3rd	1.588 (27/17)
	4th	1.200 (24/20)
	Top	0.950 (19/20)
	Reverse	2.833 (29/12 x 34/29)

ITEM	STANDARD		LIMIT
Shift fork to groove clearance	0.10 – 0.30 (0.004 – 0.012)		0.50 (0.020)
Shift fork to groove width	No.1, No.2 & No.3	4.50 – 4.60 (0.177 – 0.181)	—
	Reverse	4.00 – 4.10 (0.157 – 0.161)	—
Shift fork thickness	No.1, No.2 & No.3	4.30 – 4.40 (0.169 – 0.173)	—
	Reverse	3.80 – 3.90 (0.150 – 0.154)	—
Drive chain	Type	D.I.D.: DID520V TAKASAGO: RK520SM	—
	Links	84	—
	20-pitch length	—	319.4 (12.57)
Drive chain slack	20 – 30 (0.8 – 1.2)		—
Gearshift lever height	10 (0.4)		—

CARBURETOR

ITEM	SPECIFICATION
Carburetor type	MIKUNI VM20SS
Bore size	20 mm
I.D. No.	* 02C02
Idle r/min.	1 500 ± 50 r/min.
Float height	25.8 ± 1.0 mm (1.02 ± 0.04 in)
Main jet (M.J.)	* #87.5
Main air jet (M.A.J.)	1.0 mm
Jet needle (J.N.)	5FU96-3rd
Needle jet (N.J.)	O-1
Cut-away (C.A.)	2.5
Pilot jet (P.J.)	* #22.5
By-pass (B.P.)	1.2 mm
Pilot outlet (P.O.)	0.7 mm
Valve seat (V.S.)	1.5 mm
Starter jet (G.S.)	#22.5
Pilot screw (P.S.)	* 1 5/8 turns back
Pilot air jet (P.A.J.)	#1.3 mm
Throttle cable play	0.5 – 1.0 mm (0.02 – 0.04 in)
Choke cable play	0.5 – 1.0 mm (0.02 – 0.04 in)

ELECTRICAL

Unit: mm (in)

ITEM		SPECIFICATION		NOTE
Ignition timing		10° B.T.D.C. below 1 000 r/min. and 30° B.T.D.C. above 5000 r/min.		
Spark plug	Type	*NGK: DP7EA-9 *N.D.: X22EP-U9	P-02	
	Gap	0.8 – 0.9 (0.031 – 0.035)		
	Type	*NGK: DPR7EA-9 *N.D.: X22EPR-U9	P-24	
	Gap	0.8 – 0.9 (0.031 – 0.035)		
Spark performance		Over 8 (0.3) at 1 atm.		
Ignition coil resistance	Primary	0.1 – 1.0 Ω	Terminal – Ground	
	Secondary	10 – 25 kΩ	Plug cap – Ground	
Magneto coil resistance	Primary	350 – 550 Ω	Br – B/W	
	Pulser	200 – 400 Ω	Bl – G	
	Charging	0.6 – 1.0 Ω	Y – Y	
Generator no-load voltage		More than 55V (AC) at 5 000 r/min.		
Regulated voltage		13.5 – 15.5V at 5 000 r/min.		
Starter motor brush length	Limit:	9 (0.35)	MITSUBA	
	commutator under-cut	Limit:		0.2 (0.008)
Starter relay resistance		3 – 7 Ω		
Battery	Type designation	YB9A-A		
	Capacity	12V 32.4 kC (9 Ah)/10 HR		
	Standard electrolyte S.G.	1.28 at 20°C (68°F)		
Fuse size		15 A		

WATTAGE

Unit: W

ITEM		SPECIFICATION
Headlight	HI	45
	LO	45
Taillight		5
Reverse indicator light		3.4
Neutral indicator light		3.4

BRAKE + WHEEL

Unit: mm (in)

ITEM	STANDARD		LIMIT
Front brake lever free travel	30 (1.2)		—
Rear brake pedal free travel	20–30 (0.8–1.2)		—
Brake drum I.D.	Front	—	120.7 (4.75)
	Rear	—	150.7 (5.93)
Brake lining thickness	—		1.5 (0.06)
Steering angle	Inside	41°	—
	Outside	30°	—
Turning radius	2.4 m (7.9 ft)		—
Toe-in (with 75 kg, 165 lbs)	3–11 (0.1–0.4)		—
Caster	8°		—
Trail	31 (1.2)		—
Wheel axle runout	Rear	—	8.0 (0.31)
Tire size	Front	AT 20 x 7-8 ☆	—
	Rear	AT 22 x 10-8 ☆	—
Tire tread depth	Front	4.0 (0.16)	—
	Rear	4.0 (0.16)	—

SUSPENSION

Unit: mm (in)

ITEM	STANDARD	LIMIT	NOTE
Rear shock absorber spring setting	2nd position	—	
Front wheel travel	80 (3.1)	—	
Rear wheel travel	90 (3.5)	—	
Swingarm pivot shaft runout	—	0.6 (0.02)	

TIRE PRESSURE

COLD INFLATION TIRE PRESSURE	LOAD CAPACITY		
	130 kg (285 lbs)		
	kPa	kg/cm ²	psi
FRONT	25	0.25	3.6
REAR	20	0.20	2.9

FUEL + OIL

ITEM	SPECIFICATION		NOTE
Fuel type	Gasoline used should be graded 85-95 octane or higher. An unleaded gasoline is recommended.		
Fuel tank including reserve	8.5 L (2.2/1.9 US/Imp gal)		
reserve	1.1 L (0.3/0.2 US/Imp gal)		
Engine oil type	SAE 10W/40, API SE or SF		
Engine oil capacity	Change	1 500 ml (1.6/1.3 US/Imp qt)	
	Filter change	1 700 ml (1.8/1.5 US/Imp qt)	
	Overhaul	1 900 ml (2.0/1.8 US/Imp qt)	

HOSE ROUTING

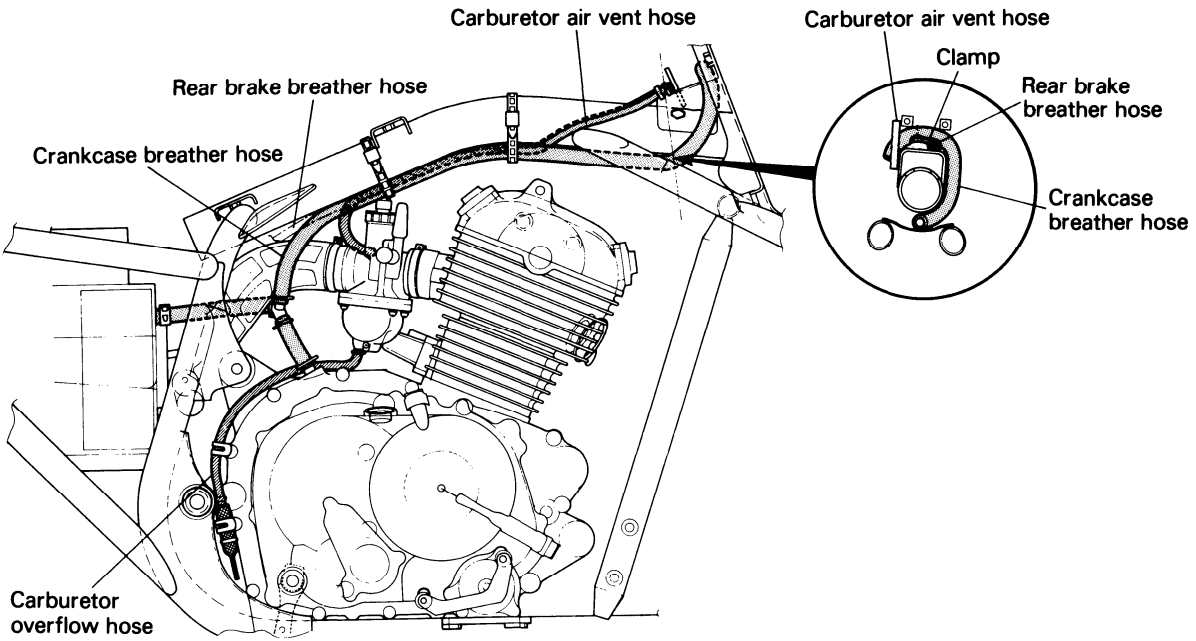

LT160EM/N ('91,'92-MODELS)

This section describes service data, service specifications and servicing procedures which differ from those of the LT160EL ('90-MODEL).

Please refer to the sections 1 through 7 for details which are not given in this section.

CONTENTS

SPECIFICATIONS	10- 1
SERVICE DATA	10- 2
WIRE ROUTING	10- 9

SPECIFICATIONS

DIMENSIONS AND DRY MASS

Overall length	1 605 mm (63.2 in)
Overall width	985 mm (38.8 in)
Overall height	1 000 mm (39.4 in)
Wheelbase	1 070 mm (42.1 in)
Ground clearance	135 mm (5.3 in)
Front track	730 mm (28.7 in)
Rear track	730 mm (28.7 in)
Seat height	725 mm (28.5 in)
Dry mass	152 kg (335 lbs)

ENGINE

Type	Four-stroke, air-cooled, OHC
Number of cylinders	1
Bore	58.0 mm (2.283 in)
Stroke	60.0 mm (2.362 in)
Piston displacement	158 cm ³ (9.6 cu. in)
Compression ratio	9.2 : 1
Carburetor	MIKUNI VM20SS, single
Air cleaner	Polyurethane foam element
Starter system	Electric
Lubrication system	Wet sump

TRANSMISSION

Clutch	Wet multi-plate type, automatic, centrifugal type
Transmission	5-speed constant mesh and 1-reverse
Gearshift pattern, forward	All up, foot lever operated
Gearshift pattern, reverse	Hand lever operated
Primary reduction ratio	3.736 (71/19)
Gear ratios, Low	3.166 (38/12)
2nd	2.142 (30/14)
3rd	1.588 (27/17)
4th	1.200 (24/20)
Top	0.950 (19/20)
Reverse	2.833 (34/12)
Final reduction ratio	3.545 (39/11)
Drive chain	TAKASAGO RK520SM or DAIDO D.I.D. 520VS, 84 links

CHASSIS

Front suspension	Independent, swing axle, coil spring, oil damped
Rear suspension	Swinging arm, coil spring, oil damped, spring preload 5-way adjustable
Caster	8°
Trail	31 mm (1.2 in)
Toe-in	7 mm (0.28 in)
Camber	1° 40'
Steering angle	42°
Turning radius	2.4 m (7.9 ft)
Front brake	Internal expanding
Rear brake	Internal expanding
Front tire size	AT20 x 7-8★
Rear tire size	AT22 x 10-8★

ELECTRICAL

Ignition type	SUZUKI "PEI"
Ignition timing	10° B.T.D.C. below 1 000 r/min and 30° B.T.D.C. above 5 000 r/min
Spark plug	NGK D7EA P03, NGK DP7EA-9 or ND X22EP-U9 P02 NGK DPR7EA-9 or ND X22EPR-U9 P28, 01
Battery	12V 32.4 kC (9Ah)/10HR
Generator	Flywheel magneto
Fuse	15A
Headlight	12V 45/45W
Taillight	12V 5W
Neutral indicator light	12V 3.4W
Reverse indicator light	12V 3.4W

CAPACITIES

Fuel tank, including reserve	8.5 L (2.2/1.9 US/Imp gal)
reserve	1.1 L (0.3/0.2 US/Imp gal)
Engine oil, oil change	1 500 ml (1.6/1.3 US/Imp qt)
with filter change	1 700 ml (1.8/1.5 US/Imp qt)

SERVICE DATA**VALVE + GUIDE**

Unit: mm (in)

ITEM	STANDARD		LIMIT
Valve diam.	IN.	28 (1.1)	—
	EX.	25 (1.0)	—
Valve lift	IN.	7.1 (0.28)	—
	EX.	6.9 (0.27)	—
Valve clearance (when cold)	IN.	0.03 – 0.08 (0.001 – 0.003)	—
	EX.	0.05 – 0.10 (0.002 – 0.004)	—
Valve guide to valve stem clearance	IN.	0.010 – 0.037 (0.0004 – 0.0015)	0.35 (0.014)
	EX.	0.030 – 0.057 (0.0012 – 0.0022)	0.35 (0.014)
Valve guide I.D.	IN. & EX.	5.500 – 5.512 (0.2165 – 0.2170)	—
Valve stem O.D.	IN.	5.475 – 5.490 (0.2155 – 0.2161)	—
	EX.	5.455 – 5.470 (0.2148 – 0.2153)	—
Valve stem runout	IN. & EX.	—	0.05 (0.002)
Valve head thickness	IN. & EX.	—	0.5 (0.02)
Valve stem end length	IN. & EX.	—	2.5 (0.10)
Valve seat width	IN. & EX.	0.9 – 1.1 (0.035 – 0.043)	—
Valve head radial runout	IN. & EX.	—	0.03 (0.001)
Valve spring free length (IN. & EX.)	—		39.5 (1.56)
Valve spring tension (IN. & EX.)	18.4 – 21.6 kg (40.6 – 47.6 lbs) at length 36.8 mm (1.45 in)		—

CAMSHAFT + CYLINDER HEAD

Unit: mm (in)

ITEM	STANDARD		LIMIT
Cam height	IN.	33.490 – 33.530 (1.3185 – 1.3201)	33.190 (1.3067)
	EX.	33.353 – 33.393 (1.3131 – 1.3147)	33.060 (1.3016)
Camshaft journal oil clearance	IN. & EX.	0.032 – 0.066 (0.0013 – 0.0026)	0.150 (0.0059)

ITEM	STANDARD		LIMIT
Camshaft journal holder I.D.	IN. & EX.	22.012 – 22.025 (0.8666 – 0.8671)	—
Camshaft journal O.D.	IN. & EX.	21.959 – 21.980 (0.8645 – 0.8654)	—
Camshaft runout	IN. & EX.	—	0.10 (0.004)
Cam chain 20-pitch length	—		129.0 (5.08)
Rocker arm I.D.	IN. & EX.	12.000 – 12.018 (0.4724 – 0.4731)	—
Rocker arm shaft O.D.	IN. & EX.	11.977 – 11.995 (0.4715 – 0.4722)	—
Cylinder head distortion	—		0.05 (0.002)
Cylinder head cover distortion	—		0.05 (0.002)

CYLINDER + PISTON + PISTON RING

Unit: mm (in)

ITEM	STANDARD		LIMIT
Compression pressure	1 000 – 1 400 kPa (10 – 14 kg/cm ²) (142 – 199 psi)		800 kPa (8 kg/cm ²) (114 psi)
Piston to cylinder clearance	0.030 – 0.040 (0.0012 – 0.0016)		0.120 (0.0047)
Cylinder bore	58.000 – 58.015 (2.2835 – 2.2841)		58.100 (2.2874)
Piston diam.	57.965 – 57.980 (2.2821 – 2.2827) Measure at 20 mm (0.79) from the skirt end.		57.880 (2.2787)
Cylinder distortion	—		0.05 (0.002)
Piston ring free end gap	1st	R Approx. 5.8 (0.23)	4.7 (0.19)
	2nd	R Approx. 7.4 (0.29)	6.0 (0.24)
Piston ring end gap	1st & 2nd	0.010 – 0.025 (0.004 – 0.010)	0.70 (0.028)
Piston ring to groove clearance	1st	—	0.180 (0.0071)
	2nd	—	0.150 (0.0059)
Piston ring groove width	1st & 2nd	1.21 – 1.23 (0.0476 – 0.0484)	—
	Oil	2.51 – 2.53 (0.0988 – 0.0996)	—
Piston ring thickness	1st & 2nd	1.17 – 1.19 (0.046 – 0.047)	—
Piston pin bore	14.002 – 14.008 (0.5513 – 0.5515)		14.030 (0.5524)
Piston pin O.D.	13.996 – 14.000 (0.5510 – 0.5512)		13.980 (0.5504)

CONROD + CRANKSHAFT

Unit: mm (in)

ITEM	STANDARD	LIMIT
Conrod small end I.D.	14.004 – 14.012 (0.5513 – 0.5517)	14.040 (0.5528)
Conrod deflection	—	3.0 (0.12)
Conrod big end side clearance	0.10 – 0.45 (0.0039 – 0.0177)	1.00 (0.039)
Conrod big end width	15.95 – 16.00 (0.628 – 0.630)	—
Crank web to web width	53.0 ± 0.1 (2.087 ± 0.004)	—
Crankshaft runout	—	0.05 (0.002)

OIL PUMP

ITEM	STANDARD	LIMIT
Oil pump reduction ratio	1.566 (47/30)	—
Oil pressure (at 60°C, 140°F)	Above 30 kPa (0.30 kg/cm ² , 4.3 psi) Below 70 kPa (0.70 kg/cm ² , 10.0 psi) at 3 000 r/min.	—

CLUTCH

Unit: mm (in)

ITEM	STANDARD	LIMIT
Clutch release screw	0 – 1/8 turn back	—
Drive plate thickness	2.7 – 2.9 (0.106 – 0.114)	2.4 (0.094)
Drive plate claw width	11.8 – 12.0 (0.46 – 0.47)	11.0 (0.43)
Driven plate distortion	—	0.10 (0.004)
Clutch spring free length	—	27.6 (1.09)
Clutch wheel I.D. (Clutch sleeve hub I.D.)	116 ± ^{0.15} ₀ (4.566 ± ^{0.006} ₀)	Scuffing or scratch on con- tacting surface
Clutch shoe	—	No groove at any part
Clutch engagement r/min.	2 200 ± 200 r/min.	—
Clutch lock-up r/min.	3 500 ± 250 r/min.	—

TRANSMISSION + DRIVE CHAIN

Unit: mm (in) Except ratio

ITEM	STANDARD	LIMIT
Primary reduction ratio	3.736 (71/19)	—
Final reduction ratio	3.545 (39/11)	—
Gear ratios	Low	3.166 (38/12)
	2nd	2.142 (30/14)
	3rd	1.588 (27/17)
	4th	1.200 (24/20)
	Top	0.950 (19/20)
	Reverse	2.833 (29/12 x 34/29)

ITEM	STANDARD		LIMIT
Shift fork to groove clearance	0.10 – 0.30 (0.004 – 0.012)		0.50 (0.020)
Shift fork to groove width	No.1, No.2 & No.3	4.50 – 4.60 (0.177 – 0.181)	—
	Reverse	4.00 – 4.10 (0.157 – 0.161)	—
Shift fork thickness	No.1, No.2 & No.3	4.30 – 4.40 (0.169 – 0.173)	—
	Reverse	3.80 – 3.90 (0.150 – 0.154)	—
Drive chain	Type	D.I.D.: DID520VS TAKASAGO: RK520SM	—
	Links	84	—
	20-pitch length	—	319.4 (12.57)
Drive chain slack	20 – 30 (0.8 – 1.2)		—
Gearshift lever height	10 (0.4)		—

CARBURETOR

ITEM	SPECIFICATION
Carburetor type	MIKUNI VM20SS
Bore size	20 mm
I.D. No.	02C02
Idle r/min.	1 500 ± 50 r/min.
Float height	25.8 ± 1.0 mm (1.02 ± 0.04 in)
Main jet (M.J.)	#87.5
Main air jet (M.A.J.)	1.0 mm
Jet needle (J.N.)	5FU96-3rd
Needle jet (N.J.)	O-1
Cut-away (C.A.)	2.5
Pilot jet (P.J.)	#22.5
By-pass (B.P.)	1.2 mm
Pilot outlet (P.O.)	0.7 mm
Valve seat (V.S.)	1.5 mm
Starter jet (G.S.)	#22.5
Pilot screw (P.S.)	1 5/8 turns back
Pilot air jet (P.A.J.)	#1.3 mm
Throttle cable play	0.5 – 1.0 mm (0.02 – 0.04 in)
Choke cable play	0.5 – 1.0 mm (0.02 – 0.04 in)

ELECTRICAL

Unit: mm (in)

ITEM		SPECIFICATION		NOTE
Ignition timing		10° B.T.D.C. below 1 000 r/min. and 30° B.T.D.C above 5 000 r/min		
Spark plug	Type	NGK: DP7EA-9 N.D.: X22EP-U9		P-02
	Gap	0.8 – 0.9 (0.031 – 0.035)		
	Type	NGK: D7EA		P-03
	Gap	0.8 – 0.9 (0.031 – 0.035)		
	Type	NGK: DPR7EA-9 N.D.: X22EPR-U9		P-01,28
	Gap	0.8 – 0.9 (0.031 – 0.035)		
Spark performance		Over 8 (0.3) at 1 atm.		
Ignition coil resistance	Primary	0.1 – 1.0 Ω		Terminal – Ground
	Secondary	10 – 25 kΩ		Plug cap – Ground
Magneto coil resistance	Primary	350 – 550 Ω		Br – B/W
	Pulser	200 – 400 Ω		Bl – G
	Charging	0.6 – 1.0 Ω		Y – Y
Generator no-load voltage		More than 55V (AC) at 5 000 r/min.		
Regulated voltage		13.5 – 15.5V at 5 000 r/min.		
Starter motor brush length	Limit:	9 (0.35)		MITSUBA
	commutator under-cut	Limit:	0.2 (0.008)	
Starter relay resistance		3 – 7 Ω		
Battery	Type designation	YB9A-A		
	Capacity	12V 32.4 kC (9 Ah)/10 HR		
	Standard electrolyte S.G.	1.28 at 20°C (68°F)		
Fuse size		15 A		

WATTAGE

Unit: W

ITEM		SPECIFICATION
Headlight	HI	45
	LO	45
Taillight		5
Reverse indicator light		3.4
Neutral indicator light		3.4

BRAKE + WHEEL

Unit: mm (in)

ITEM	STANDARD		LIMIT
Front brake lever free travel	30 (1.2)		—
Rear brake pedal free travel	20–30 (0.8–1.2)		—
Brake drum I.D.	Front	—	120.7 (4.75)
	Rear	—	150.7 (5.93)
Brake lining thickness	—		1.5 (0.06)
Steering angle	Inside	41°	—
	Outside	30°	—
Turning radius	2.4 m (7.9 ft)		—
Toe-in (with 75 kg, 165 lbs)	3–11 (0.1–0.4)		—
Caster	8°		—
Trail	31 (1.2)		—
Wheel axle runout	Rear	—	8.0 (0.31)
Tire size	Front	AT 20 x 7-8 ☆	—
	Rear	AT 22 x 10-8 ☆	—
Tire tread depth	Front	4.0 (0.16)	—
	Rear	4.0 (0.16)	—

SUSPENSION

Unit: mm (in)

ITEM	STANDARD	LIMIT	NOTE
Rear shock absorber spring setting	2nd position	—	
Front wheel travel	80 (3.1)	—	
Rear wheel travel	90 (3.5)	—	
Swingarm pivot shaft runout	—	0.6 (0.02)	

TIRE PRESSURE

COLD INFLATION TIRE PRESSURE	LOAD CAPACITY					
	UP TO 80kg (175 lbs)			80–130 kg (175–285 lbs)		
	kPa	kg/cm ²	psi	kPa	kg/cm ²	psi
FRONT	17.5	0.175	2.5	25	0.25	3.6
REAR	15	0.15	2.2	20	0.20	2.9

FUEL + OIL

ITEM	SPECIFICATION		NOTE
Fuel type	Use only unleaded or low-lead type gasoline of at least 85 pump octane ($\frac{R+M}{2}$) or 91 octane or higher rated by the research method. Gasoline containing MTBE (Methyl Tertiary Butyl Ether), less than 10% ethanol, or less than 5% methanol with appropriate cosolvents and corrosion inhibitor is permissible.		P-03
	Use only unleaded gasoline of at least 87 pump octane ($\frac{R+M}{2}$ method) or 91 octane or higher rated by the Research Method.		P-28
	Gasoline used should be graded 85-95 octane or higher. An unleaded gasoline is recommended.		For the others
Fuel tank including reserve	8.5 L (2.2/1.9 US/lmp gal)		
reserve	1.1 L (0.3/0.2 US/lmp gal)		
Engine oil type	SAE 10W/40, API SE or SF		
Engine oil capacity	Change	1 500 ml (1.6/1.3 US/lmp qt)	
	Filter change	1 700 ml (1.8/1.5 US/lmp qt)	
	Overhaul	1 900 ml (2.0/1.8 US/lmp qt)	

LT-F160N/P ('92,'93-MODELS)

This section describes service data and service specifications which differ from those of the LT-F160M ('91-MODEL).

Please refer to the sections 1 through 7 for details which are not given in this section.

CONTENTS

SPECIFICATIONS	11- 1
SERVICE DATA	11- 2

SPECIFICATIONS

DIMENSIONS AND DRY MASS

Overall length	1 670 mm (65.7 in)
Overall width	985 mm (38.8 in)
Overall height	1 000 mm (39.4 in)
Wheelbase	1 070 mm (42.1 in)
Ground clearance	135 mm (5.3 in)
Front track	730 mm (28.7 in)
Rear track	730 mm (28.7 in)
Seat height	725 mm (28.5 in)
Dry mass	162 kg (357 lbs)

ENGINE

Type	Four-stroke, air-cooled, OHC
Number of cylinders	1
Bore	58.0 mm (2.283 in)
Stroke	60.0 mm (2.362 in)
Piston displacement	158 cm ³ (9.6 cu. in)
Compression ratio	9.2 : 1
Carburetor	MIKUNI VM20SS, single
Air cleaner	Polyurethane foam element
Starter system	Electric
Lubrication system	Wet sump

TRANSMISSION

Clutch	Wet multi-plate type, automatic, centrifugal type
Transmission	5-speed constant mesh and 1-reverse
Gearshift pattern, forward	All up, foot lever operated
Gearshift pattern, reverse	Hand lever operated
Primary reduction ratio	3.736 (71/19)
Gear ratios, Low	3.166 (38/12)
2nd	2.142 (30/14)
3rd	1.588 (27/17)
4th	1.200 (24/20)
Top	0.950 (19/20)
Reverse	2.833 (34/12)
Final reduction ratio	3.545 (39/11)
Drive chain	TAKASAGO RK520SM or DAIDO D.I.D. 520VS, 84 links

CHASSIS

Front suspension	Independent, swing axle, coil spring, oil damped
Rear suspension	Swinging arm, coil spring, oil damped, spring preload 5-way adjustable
Caster	8°
Trail	31 mm (1.2 in)
Toe-in	7 mm (0.28 in)
Camber	1° 40'
Steering angle	42°
Turning radius	2.4 m (7.9 ft)
Front brake	Internal expanding
Rear brake	Internal expanding
Front tire size	AT20 x 7-8★
Rear tire size	AT22 x 10-8★

ELECTRICAL

Ignition type	SUZUKI "PEI"
Ignition timing	10° B.T.D.C. below 1 000 r/min and 30° B.T.D.C. above 5 000 r/min
Spark plug	NGK DP7EA-9 or ND X22EP-U9 . . . P02, 03; NGK DPR7EA-9 or ND X22EPR-U9 . . . P24, P28 (P-MODEL)
Battery	12V 32.4 kC (9 Ah)/10 HR
Generator	Flywheel magneto
Fuse	15A
Headlight	12V 45/45W
Taillight	12V 5W
Neutral indicator light	12V 3.4W
Reverse indicator light	12V 3.4W

CAPACITIES

Fuel tank, including reserve	8.5 L (2.2/1.9 US/Imp gal)
reserve	1.1 L (0.3/0.2 US/Imp gal)
Engine oil, oil change	1 500 ml (1.6/1.3 US/Imp qt)
with filter change	1 700 ml (1.8/1.5 US/Imp qt)

SERVICE DATA

VALVE + GUIDE

Unit: mm (in)

ITEM	STANDARD		LIMIT
Valve diam.	IN.	28 (1.1)	—
	EX.	25 (1.0)	—
Valve lift	IN.	7.1 (0.28)	—
	EX.	6.9 (0.27)	—
Valve clearance (when cold)	IN.	0.03–0.08 (0.001–0.003)	—
	EX.	0.05–0.10 (0.002–0.004)	—
Valve guide to valve stem clearance	IN.	0.010–0.037 (0.0004–0.0015)	0.35 (0.014)
	EX.	0.030–0.057 (0.0012–0.0022)	0.35 (0.014)
Valve guide I.D.	IN. & EX.	5.500–5.512 (0.2165–0.2170)	—
Valve stem O.D.	IN.	5.475–5.490 (0.2155–0.2161)	—
	EX.	5.455–5.470 (0.2148–0.2153)	—
Valve stem runout	IN. & EX.	—	0.05 (0.002)
Valve head thickness	IN. & EX.	—	0.5 (0.02)
Valve stem end length	IN. & EX.	—	2.5 (0.10)
Valve seat width	IN. & EX.	0.9–1.1 (0.035–0.043)	—
Valve head radial runout	IN. & EX.	—	0.03 (0.001)
Valve spring free length (IN. & EX.)	—		39.5 (1.56)
Valve spring tension (IN. & EX.)	18.4–21.6 kg (40.6–47.6 lbs) at length 36.8 mm (1.45 in)		—

CAMSHAFT + CYLINDER HEAD

Unit: mm (in)

ITEM	STANDARD		LIMIT	
Cam height	E-03	IN.	33.768–33.808 (1.3295–1.3310)	33.470 (1.3177)
		EX.	33.390–33.430 (1.3146–1.3161)	33.090 (1.3028)
	The others	IN.	33.490–33.530 (1.3185–1.3201)	33.190 (1.3067)
		EX.	33.353–33.393 (1.3131–1.3147)	33.060 (1.3016)

ITEM	STANDARD		LIMIT
Camshaft journal oil clearance	IN. & EX.	0.032–0.066 (0.0013–0.0026)	0.150 (0.0059)
Camshaft journal holder I.D.	IN. & EX.	22.012–22.025 (0.8666–0.8671)	—
Camshaft journal O.D.	IN. & EX.	21.959–21.980 (0.8645–0.8654)	—
Camshaft runout	IN. & EX.	—	0.10 (0.004)
Cam chain 20-pitch length	—		129.0 (5.08)
Rocker arm I.D.	IN. & EX.	12.000–12.018 (0.4724–0.4731)	—
Rocker arm shaft O.D.	IN. & EX.	11.977–11.995 (0.4715–0.4722)	—
Cylinder head distortion	—		0.05 (0.002)
Cylinder head cover distortion	—		0.05 (0.002)

CYLINDER + PISTON + PISTON RING

Unit: mm (in)

ITEM	STANDARD		LIMIT
Compression pressure	1 000–1 400 kPa (10–14 kg/cm ²) (142–199 psi)		800 kPa (8 kg/cm ²) (114 psi)
Piston to cylinder clearance	0.030–0.040 (0.0012–0.0016)		0.120 (0.0047)
Cylinder bore	58.000–58.015 (2.2835–2.2841)		58.100 (2.2874)
Piston diam.	57.965–57.980 (2.2821–2.2827) Measure at 20 mm (0.8 in) from the skirt end.		57.880 (2.2787)
Cylinder distortion	—		0.05 (0.002)
Piston ring free end gap	1st	R	Approx. 5.8 (0.23)
	2nd	R	Approx. 7.4 (0.29)
Piston ring end gap	1st & 2nd	0.010–0.025 (0.004–0.010)	0.70 (0.028)
Piston ring to groove clearance	1st	—	0.180 (0.0071)
	2nd	—	0.150 (0.0059)
Piston ring groove width	1st & 2nd	1.21–1.23 (0.0476–0.0484)	—
	Oil	2.51–2.53 (0.0988–0.0996)	—
Piston ring thickness	1st & 2nd	1.17–1.19 (0.046–0.047)	—
Piston pin bore	14.002–14.008 (0.5513–0.5515)		14.030 (0.5524)
Piston pin O.D.	13.996–14.000 (0.5510–0.5512)		13.980 (0.5504)

CONROD + CRANKSHAFT

Unit: mm (in)

ITEM	STANDARD	LIMIT
Conrod small end I.D.	14.004 – 14.012 (0.5513 – 0.5517)	14.040 (0.5528)
Conrod deflection	—	3.0 (0.12)
Conrod big end side clearance	0.10 – 0.45 (0.0039 – 0.0177)	1.00 (0.039)
Conrod big end width	15.95 – 16.00 (0.628 – 0.630)	—
Crank web to web width	53.0 ± 0.1 (2.087 ± 0.004)	—
Crankshaft runout	—	0.05 (0.002)

OIL PUMP

ITEM	STANDARD	LIMIT
Oil pump reduction ratio	1.566 (47/30)	—
Oil pressure (at 60°C, 140°F)	Above 30 kPa (0.30 kg/cm ² , 4.3 psi) Below 70 kPa (0.70 kg/cm ² , 10.0 psi) at 3 000 r/min.	—

CLUTCH

Unit: mm (in)

ITEM	STANDARD	LIMIT
Clutch release screw	0 – 1/8 turn back	—
Drive plate thickness	2.7 – 2.9 (0.106 – 0.114)	2.4 (0.094)
Drive plate claw width	11.8 – 12.0 (0.46 – 0.47)	11.0 (0.43)
Driven plate distortion	—	0.10 (0.004)
Clutch spring free length	—	27.6 (1.09)
Clutch wheel I.D. (Clutch sleeve hub I.D.)	116 ^{+0.15} ₋₀ (4.566 ^{+0.006} ₋₀)	Scuffing or scratch on con- tacting surface
Clutch shoe	—	No groove at any part
Clutch engagement r/min.	2 200 ± 200 r/min.	—
Clutch lock-up r/min.	3 500 ± 250 r/min.	—

TRANSMISSION + DRIVE CHAIN

Unit: mm (in) Except ratio

ITEM	STANDARD	LIMIT
Primary reduction ratio	3.736 (71/19)	—
Final reduction ratio	3.545 (39/11)	—
Gear ratios	Low	3.166 (38/12)
	2nd	2.142 (30/14)
	3rd	1.588 (27/17)
	4th	1.200 (24/20)
	Top	0.950 (19/20)
	Reverse	2.833 (29/12 x 34/29)

ITEM	STANDARD		LIMIT
Shift fork to groove clearance	0.10–0.30 (0.004–0.012)		0.50 (0.020)
Shift fork to groove width	No. 1, No. 2 & No. 3	4.50–4.60 (0.177–0.181)	—
	Reverse	4.00–4.10 (0.157–0.161)	—
Shift fork thickness	No. 1, No. 2 & No. 3	4.30–4.40 (0.169–0.173)	—
	Reverse	3.80–3.90 (0.150–0.154)	—
Drive chain	Type	D.I.D.: DID520V TAKASAGO: RK520SM	—
	Links	84	—
	20-pitch length	—	319.4 (12.57)
Drive chain slack	20–30 (0.8–1.2)		—
Gearshift lever height	10 (0.4)		—

CARBURETOR

ITEM	SPECIFICATION
Carburetor type	MIKUNI VM20SS
Bore size	20 mm
I.D. No.	02C02
Idle r/min.	1 500 ± 50 r/min.
Float height	25.8 ± 1.0 mm (1.02 ± 0.04 in)
Main jet (M.J.)	# 87.5
Main air jet (M.A.J.)	1.0 mm
Jet needle (J.N.)	5FU96-3rd
Needle jet (N.J.)	O-1
Cut-away (C.A.)	2.5
Pilot jet (P.J.)	# 22.5
By-pass (B.P.)	1.2 mm
Pilot outlet (P.O.)	0.7 mm
Valve seat (V.S.)	1.5 mm
Starter jet (G.S.)	# 22.5
Pilot screw (P.S.)	1 5/8 turns back
Pilot air jet (P.A.J.)	1.3 mm
Throttle cable play	0.5–1.0 mm (0.02–0.04 in)
Choke cable play	0.5–1.0 mm (0.02–0.04 in)

ELECTRICAL

Unit: mm (in)

ITEM		SPECIFICATION		NOTE
Ignition timing		10° B.T.D.C. below 1 000 r/min. and 30° B.T.D.C. above 5 000 r/min.		
Spark plug	Type	NGK: DP7EA-9 ND: X22EP-U9		P-02, 03
	Gap	0.8–0.9 (0.031–0.035)		
	Type	NGK: DPR7EA-9 ND: X22EPR-U9		P-24 P-28 (P-MODEL)
	Gap	0.8–0.9 (0.031–0.035)		
Spark performance		Over 8 (0.3) at 1 atm.		
Ignition coil resistance	Primary	0.1–1.0 Ω		Terminal– Ground
	Secondary	10–25 kΩ		Plug cap– Ground
Magneto coil resistance	Primary	350–550 Ω		Br–B/W
	Pulser	200–400 Ω		Bl–G
	Charging	0.6–1.0 Ω		Y–Y
Generator no-load voltage		More than 55 V (AC) at 5 000 r/min.		
Regulated voltage		13.5–15.5 V at 5 000 r/min.		
Starter motor brush length	Limit:	9 (0.35)		MITSUBA
	commutator under-cut	Limit:	0.2 (0.008)	
Starter relay resistance		3–7 Ω		
Battery	Type designation	YB9A-A		
	Capacity	12 V 32.4 kC (9 Ah)/10 HR		
	Standard electrolyte S.G.	1.28 at 20°C (68°F)		
Fuse size		15 A		

WATTAGE

Unit:W

ITEM		SPECIFICATION
Headlight	HI	45
	LO	45
Taillight		5
Reverse indicator light		3.4
Neutral indicator light		3.4

BRAKE + WHEEL

Unit: mm (in)

ITEM	STANDARD		LIMIT
Front brake lever free travel	30 (1.2)		—
Rear brake pedal free travel	20–30 (0.8–1.2)		—
Brake drum I.D.	Front	—	120.7 (4.75)
	Rear	—	150.7 (5.93)
Brake lining thickness	—		1.5 (0.06)
Steering angle	Inside	41°	—
	Outside	30°	—
Turning radius	2.4 m (7.9 ft)		—
Toe-in (with 75 kg, 165 lbs)	3–11 (0.1–0.4)		—
Caster	8°		—
Trail	31 (1.2)		—
Wheel axle runout	Rear	—	8.0 (0.31)
Tire size	Front	AT 20 x 7-8☆	—
	Rear	AT 22 x 10-8☆	—
Tire tread depth	Front	4.0 (0.16)	—
	Rear	4.0 (0.16)	—

SUSPENSION

Unit: mm (in)

ITEM	STANDARD	LIMIT	NOTE
Rear shock absorber spring setting	2nd position	—	
Front wheel travel	80 (3.1)	—	
Rear wheel travel	90 (3.5)	—	
Swingarm pivot shaft runout	—	0.6 (0.02)	

TIRE PRESSURE

COLD INFLATION TIRE PRESSURE	LOAD CAPACITY		
	130 kg (285 lbs)		
	kPa	kg/cm ²	psi
FRONT	25	0.25	3.6
REAR	20	0.20	2.9

FUEL + OIL

ITEM	SPECIFICATION		NOTE
Fuel type	Use only unleaded gasoline of at least 85 pump octane ($\frac{R+M}{2}$) or 91 octane or higher rated by the research method. Gasoline containing MTBE (Methyl Tertiary Butyl Ether), less than 10% ethanol, or less than 5% methanol with appropriate cosolvents and corrosion inhibitor is permissible.		P-03
	Use only unleaded gasoline of at least 87 pump octane ($\frac{R+M}{2}$ method) or 91 octane or higher rated by the Research Method.		P-28 (P-MODEL)
	Gasoline used should be graded 85–95 octane or higher. An unleaded gasoline is recommended.		The others
Fuel tank including reserve	8.5 L (2.2/1.9 US/Imp gal)		
reserve	1.1 L (0.3/0.2 US/Imp gal)		
Engine oil type	SAE 10W/40, API SE or SF		
Engine oil capacity	Change	1 500 ml (1.6/1.3 US/Imp qt)	
	Filter change	1 700 ml (1.8/1.5 US/Imp qt)	
	Overhaul	1 900 ml (2.0/1.8 US/Imp qt)	

LT-F160R/S/T/V (1994 to 1997-MODELS)

This section describes service data and service specifications which differ from those of the LT-F160P ('93-MODEL).

Please refer to the sections 1 through 7 for details which are not given in this section.

CONTENTS

SPECIFICATIONS	12- 1
SERVICE DATA	12- 2

SPECIFICATIONS

DIMENSIONS AND DRY MASS

Overall length	1 670 mm (65.7 in)
Overall width	985 mm (38.8 in)
Overall height	1 000 mm (39.4 in)
Wheelbase	1 070 mm (42.1 in)
Ground clearance	135 mm (5.3 in)
Front track	730 mm (28.7 in)
Rear track	730 mm (28.7 in)
Seat height	725 mm (28.5 in)
Dry mass	162 kg (357 lbs)

ENGINE

Type	Four-stroke, air-cooled, OHC
Number of cylinder	1
Bore	58.0 mm (2.283 in)
Stroke	60.0 mm (2.362 in)
Piston displacement	158 cm ³ (9.6 cu. in)
Compression ratio	9.2 : 1
Carburetor	VM20SS, single
Air cleaner	Polyurethane foam element
Starter system	Electric
Lubrication system	Wet sump

TRANSMISSION

Clutch	Wet multi-plate type, automatic, centrifugal type
Transmission	5-speed constant mesh and 1-reverse
Gearshift pattern, forward	All up, foot lever operated
Gearshift pattern, reverse	Hand lever operated
Primary reduction ratio	3.736 (71/19)
Gear ratios, Low	3.166 (38/12)
2nd	2.142 (30/14)
3rd	1.588 (27/17)
4th	1.200 (24/20)
Top	0.950 (19/20)
Reverse	2.833 (34/12)
Final reduction ratio	3.545 (39/11)
Drive chain	RK520SM or D.I.D. 520VS, 84 links

CHASSIS

Front suspension	Independent, swing axle, coil spring, oil damped
Rear suspension	Swinging arm, coil spring, oil damped, spring preload 5-way adjustable
Caster	8°
Trail	31 mm (1.2 in)
Toe-in	7 mm (0.28 in)
Camber	1° 40'
Steering angle	42°
Turning radius	2.4 m (7.9 ft)
Front brake	Internal expanding
Rear brake	Internal expanding
Front tire size	AT20 x 7-8★
Rear tire size	AT22 x 10-8★

ELECTRICAL

Ignition type	Electronic ignition
Ignition timing	10° B.T.D.C. below 1 000 r/min and 30° B.T.D.C. above 5 000 r/min
Spark plug	NGK DP7EA-9 or NIPPONDENSO X22EP-U9 . . . P02 (R,S,T-MODELS), P03, P33 (V-MODEL)
Battery	NGK DPR7EA-9 or NIPPONDENSO X22ERP-U9 . . . P24, 28
Generator	12V 32.4 kC (9 Ah)/10 HR
Fuse	Flywheel magneto
Headlight	15A
Taillight	12V 45/45W
Neutral indicator light	12V 5W
Reverse indicator light	12V 3.4W
	12V 3.4W

CAPACITIES

Fuel tank including reserve	8.5 L (2.2/1.9 US/Imp gal)
reserve	1.1 L (0.3/0.2 US/Imp gal)
Engine oil, oil change	1 500 ml (1.6/1.3 US/Imp qt)
with filter change	1 700 ml (1.8/1.5 US/Imp qt)

SERVICE DATA**VALVE + GUIDE**

Unit: mm (in)

ITEM	STANDARD		LIMIT
Valve diam.	IN.	28 (1.1)	—
	EX.	25 (1.0)	—
Valve lift	IN.	7.1 (0.28)	—
	EX.	6.9 (0.27)	—
Valve clearance (when cold)	IN.	0.03–0.08 (0.001–0.003)	—
	EX.	0.05–0.10 (0.002–0.004)	—
Valve guide to valve stem clearance	IN.	0.010–0.037 (0.0004–0.0015)	—
	EX.	0.030–0.057 (0.0012–0.0022)	—
Valve stem deflection	IN. & EX.	—	0.35 (0.014)
Valve guide I.D.	IN. & EX.	5.500–5.512 (0.2165–0.2170)	—
Valve stem O.D.	IN.	5.475–5.490 (0.2155–0.2161)	—
	EX.	5.455–5.470 (0.2148–0.2153)	—
Valve stem runout	IN. & EX.	—	0.05 (0.002)
Valve head thickness	IN. & EX.	—	0.5 (0.02)
Valve stem end length	IN. & EX.	—	2.5 (0.10)
Valve seat width	IN. & EX.	0.9–1.1 (0.035–0.043)	—
Valve head radial runout	IN. & EX.	—	0.03 (0.001)
Valve spring free length (IN. & EX.)	—		39.5 (1.56)
Valve spring tension (IN. & EX.)	18.4–21.6 kg (40.6–47.6 lbs) at length 36.8 mm (1.45 in)		—

CAMSHAFT + CYLINDER HEAD

Unit: mm (in)

ITEM	STANDARD		LIMIT	
Cam height	P-03	IN.	33.768–33.808 (1.3295–1.3310)	33.470 (1.3177)
		EX.	33.390–33.430 (1.3146–1.3161)	33.090 (1.3028)
	The others	IN.	33.490–33.530 (1.3185–1.3201)	33.190 (1.3067)
		EX.	33.353–33.393 (1.3131–1.3147)	33.060 (1.3016)

ITEM	STANDARD		LIMIT
Camshaft journal oil clearance	IN. & EX.	0.032–0.066 (0.0013–0.0026)	0.150 (0.0059)
Camshaft journal holder I.D.	IN. & EX.	22.012–22.025 (0.8666–0.8671)	—
Camshaft journal O.D.	IN. & EX.	21.959–21.980 (0.8645–0.8654)	—
Camshaft runout	IN. & EX.	—	0.10 (0.004)
Rocker arm I.D.	IN. & EX.	12.000–12.018 (0.4724–0.4731)	—
Rocker arm shaft O.D.	IN. & EX.	11.977–11.995 (0.4715–0.4722)	—
Cylinder head distortion	—		0.05 (0.002)
Cylinder head cover distortion	—		0.05 (0.002)

CYLINDER + PISTON + PISTON RING

Unit: mm (in)

ITEM	STANDARD		LIMIT	
Compression pressure	1 000–1 400 kPa (10–14 kg/cm ²) (142–199 psi)		800 kPa (8 kg/cm ²) (114 psi)	
Piston to cylinder clearance	0.030–0.040 (0.0012–0.0016)		0.120 (0.0047)	
Cylinder bore	58.000–58.015 (2.2835–2.2841)		58.100 (2.2874)	
Piston diam.	57.965–57.980 (2.2821–2.2827) Measure at 20 mm (0.8 in) from the skirt end.		57.880 (2.2787)	
Cylinder distortion	—		0.05 (0.002)	
Piston ring free end gap	1st	R	Approx. 5.8 (0.23)	4.7 (0.19)
	2nd	R	Approx. 7.4 (0.29)	6.0 (0.24)
Piston ring end gap	1st & 2nd		0.010–0.025 (0.004–0.010)	0.70 (0.028)
Piston ring to groove clearance	1st		—	0.180 (0.0071)
	2nd		—	0.150 (0.0059)
Piston ring groove width	1st & 2nd		1.21–1.23 (0.0476–0.0484)	—
	Oil		2.51–2.53 (0.0988–0.0996)	—
Piston ring thickness	1st & 2nd		1.17–1.19 (0.046–0.047)	—
Piston pin bore	14.002–14.008 (0.5513–0.5515)		14.030 (0.5524)	
Piston pin O.D.	13.996–14.000 (0.5510–0.5512)		13.980 (0.5504)	

CONROD + CRANKSHAFT

Unit: mm (in)

ITEM	STANDARD	LIMIT
Conrod small end I.D.	14.004 – 14.012 (0.5513 – 0.5517)	14.040 (0.5528)
Conrod deflection	—	3.0 (0.12)
Conrod big end side clearance	0.10 – 0.45 (0.0039 – 0.0177)	1.00 (0.039)
Conrod big end width	15.95 – 16.00 (0.628 – 0.630)	—
Crank web to web width	53.0 ± 0.1 (2.087 ± 0.004)	—
Crankshaft runout	—	0.05 (0.002)

OIL PUMP

ITEM	STANDARD	LIMIT
Oil pump reduction ratio	1.566 (47/30)	—
Oil pressure (at 60°C, 140°F)	Above 30 kPa (0.30 kg/cm ² , 4.3 psi) Below 70 kPa (0.70 kg/cm ² , 10.0 psi) at 3 000 r/min.	—

CLUTCH

Unit: mm (in)

ITEM	STANDARD	LIMIT
Clutch release screw	0 – 1/8 turn back	—
Drive plate thickness	2.7 – 2.9 (0.106 – 0.114)	2.4 (0.094)
Drive plate claw width	11.8 – 12.0 (0.46 – 0.47)	11.0 (0.43)
Driven plate distortion	—	0.10 (0.004)
Clutch spring free length	—	27.6 (1.09)
Clutch wheel I.D. (Clutch sleeve hub I.D.)	116 ^{+0.15} ₋₀ (4.566 ^{+0.006} ₋₀)	Scuffing or scratch on con- tacting surface
Clutch shoe	—	No groove at any part
Clutch engagement r/min.	2 200 ± 200 r/min.	—
Clutch lock-up r/min.	3 500 ± 250 r/min.	—

TRANSMISSION + DRIVE CHAIN

Unit: mm (in) Except ratio

ITEM	STANDARD	LIMIT
Primary reduction ratio	3.736 (71/19)	—
Final reduction ratio	3.545 (39/11)	—
Gear ratios	Low	3.166 (38/12)
	2nd	2.142 (30/14)
	3rd	1.588 (27/17)
	4th	1.200 (24/20)
	Top	0.950 (19/20)
	Reverse	2.833 (29/12 x 34/29)

ITEM	STANDARD		LIMIT
Shift fork to groove clearance	0.10–0.30 (0.004–0.012)		0.50 (0.020)
Shift fork to groove width	No.1, No.2 & No.3	4.50–4.60 (0.177–0.181)	—
	Reverse	4.00–4.10 (0.157–0.161)	—
Shift fork thickness	No.1, No.2 & No.3	4.30–4.40 (0.169–0.173)	—
	Reverse	3.80–3.90 (0.150–0.154)	—
Drive chain	Type	D.I.D.: DID520V TAKASAGO: RK520SM	—
	Links	84	—
	20-pitch length	—	319.4 (12.57)
Drive chain slack	20–30 (0.8–1.2)		—
Gearshift lever height	10 (0.4)		—

CARBURETOR

ITEM	SPECIFICATION
Carburetor type	MIKUNI VM20SS
Bore size	20 mm
I.D. No.	02C02
Idle r/min.	1 500 ± 50 r/min.
Float height	25.8 ± 1.0 mm (1.02 ± 0.04 in)
Main jet (M.J.)	# 87.5
Main air jet (M.A.J.)	1.0 mm
Jet needle (J.N.)	5FU96-3rd
Needle jet (N.J.)	O-1
Cut-away (C.A.)	2.5
Pilot jet (P.J.)	# 22.5
By-pass (B.P.)	1.2 mm
Pilot outlet (P.O.)	0.7 mm
Valve seat (V.S.)	1.5 mm
Starter jet (G.S.)	# 22.5
Pilot screw (P.S.)	1 5/8 turns back
Pilot air jet (P.A.J.)	1.3 mm
Throttle cable play	*1–3 mm (0.04–0.12 in)
Starter cable play	0.5–1.0 mm (0.02–0.04 in)

Asterisk mark (*) indicates the New "R" model specification.

ELECTRICAL

Unit: mm (in)

ITEM		SPECIFICATION		NOTE
Ignition timing		10° B.T.D.C. below 1 000 r/min. and 30° B.T.D.C. above 5 000 r/min.		
Spark plug	Type	NGK: DP7EA-9 ND: X22EP-U9		P-02 (R,S,T-MODELS) P-33 (V-MODEL)
	Gap	0.8–0.9 (0.031–0.035)		
	Type	NGK: DPR7EA-9 ND: X22EPR-U9		P-24,28
	Gap	0.8–0.9 (0.031–0.035)		
Spark performance		Over 8 (0.3) at 1 atm.		
Ignition coil resistance	Primary	0.1–1.0 Ω		Terminal– Ground
	Secondary	10–25 kΩ		Plug cap– Ground
Magneto coil resistance	Primary	350–550 Ω		Br–B/W
	Pulser	200–400 Ω		Bl–G
	Charging	0.6–1.0 Ω		Y–Y
Generator no-load voltage		More than 55 V (AC) at 5 000 r/min.		
Generator Max. output		Approx. 150 W at 5 000 r/min.		
Regulated voltage		13.5–15.5 V at 5 000 r/min.		
Starter motor brush length	Limit:	9 (0.35)		MITSUBA
	commutator under-cut	Limit:	0.2 (0.008)	
Starter relay resistance		3–7 Ω		
Battery	Type designation	YB9A-A		
	Capacity	12 V 32.4 kC (9 Ah)/10 HR		
	Standard electrolyte S.G.	1.28 at 20°C (68°F)		
Fuse size		15 A		

WATTAGE

Unit:W

ITEM		SPECIFICATION
Headlight	HI	45
	LO	45
Taillight		5
Reverse indicator light		3.4
Neutral indicator light		3.4

BRAKE + WHEEL

Unit: mm (in)

ITEM	STANDARD		LIMIT
Front brake lever free travel	30 (1.2)		—
Rear brake pedal free travel	20–30 (0.8–1.2)		—
Brake drum I.D.	Front	—	120.7 (4.75)
	Rear	—	150.7 (5.93)
Brake lining thickness	—		1.5 (0.06)
Steering angle	Inside	41°	—
	Outside	30°	—
Turning radius	2.4 m (7.9 ft)		—
Toe-in (with 75 kg, 165 lbs)	3–11 (0.1–0.4)		—
Caster	8°		—
Trail	31 (1.2)		—
Wheel axle runout	Rear	—	8.0 (0.31)
Wheel rim size	Front	8 x 5.5 AT	—
	Rear	8 x 8.0 AT	—
Tire size	Front	AT 20 x 7-8☆	—
	Rear	AT 22 x 10-8☆	—
Tire tread depth	Front	4.0 (0.16)	—
	Rear	4.0 (0.16)	—

SUSPENSION

Unit: mm (in)

ITEM	STANDARD	LIMIT	NOTE
Rear shock absorber spring setting	2nd position	—	
Front wheel travel	80 (3.1)	—	
Rear wheel travel	90 (3.5)	—	
Swingarm pivot shaft runout	—	0.6 (0.02)	

TIRE PRESSURE

COLD INFLATION TIRE PRESSURE	LOAD CAPACITY		
	130 kg (285 lbs)		
	kPa	kg/cm ²	psi
FRONT	25	0.25	3.6
REAR	20	0.20	2.9

FUEL + OIL

ITEM	SPECIFICATION		NOTE
Fuel type	Use only unleaded gasoline of at least 85 pump octane ($\frac{R+M}{2}$) or 91 octane or higher rated by the research method. Gasoline containing MTBE (Methyl Tertiary Butyl Ether), less than 10% ethanol, or less than 5% methanol with appropriate cosolvents and corrosion inhibitor is permissible.		P-03
	Use only unleaded gasoline of at least 87 pump octane ($\frac{R+M}{2}$ method) or 91 octane or higher rated by the Research Method.		P-28
	Gasoline used should be graded 85–95 octane or higher. An unleaded gasoline is recommended.		The others
Fuel tank including reserve	8.5 L (2.2/1.9 US/Imp gal)		
reserve	1.1 L (0.3/0.2 US/Imp gal)		
Engine oil type	SAE 10W/40, API SE, SF or SG		
Engine oil capacity	Change	1 500 ml (1.6/1.3 US/Imp qt)	
	Filter change	1 700 ml (1.8/1.5 US/Imp qt)	
	Overhaul	1 900 ml (2.0/1.8 US/Imp qt)	

LT-F160W/X ('98,'99-MODELS)

This section describes service data and service specifications which differ from those of the LT-F160V ('97-MODEL).

Please refer to the sections 1 through 7 for details which are not given in this section.

CONTENTS

SPECIFICATIONS	13- 1
SERVICE DATA	13- 2

SPECIFICATIONS

DIMENSIONS AND DRY MASS

Overall length	1 670 mm (65.7 in)
Overall width	985 mm (38.8 in)
Overall height	1 000 mm (39.4 in)
Wheelbase	1 070 mm (42.1 in)
Ground clearance	135 mm (5.3 in)
Front track	730 mm (28.7 in)
Rear track	730 mm (28.7 in)
Seat height	725 mm (28.5 in)
Dry mass	162 kg (357 lbs)

ENGINE

Type	Four-stroke, air-cooled, OHC
Number of cylinder	1
Bore	58.0 mm (2.283 in)
Stroke	60.0 mm (2.362 in)
Piston displacement	158 cm ³ (9.6 cu. in)
Compression ratio	9.2 : 1
Carburetor	VM20SS, single . . . The others BS26SS, single . . . P33
Air cleaner	Polyurethane foam element
Starter system	Electric
Lubrication system	Wet sump

TRANSMISSION

Clutch	Wet multi-plate type, automatic, centrifugal type
Transmission	5-speed constant mesh and 1-reverse
Gearshift pattern, forward	All up, foot lever operated
Gearshift pattern, reverse	Hand lever operated
Primary reduction ratio	3.736 (71/19)
Gear ratios, Low	3.166 (38/12)
2nd	2.142 (30/14)
3rd	1.588 (27/17)
4th	1.200 (24/20)
Top	0.950 (19/20)
Reverse	2.833 (34/12)
Final reduction ratio	3.545 (39/11)
Drive chain	RK520SM, 88 links . . . P-51 RK520SM, 84 links . . . The others

CHASSIS

Front suspension	Independent, swing axle, coil spring, oil damped
Rear suspension	Swinging arm, coil spring, oil damped, spring preload 5-way adjustable
Caster	8°
Trail	31 mm (1.2 in)
Toe-in	7 mm (0.28 in)
Camber	1° 40'
Steering angle	42°
Turning radius	2.4 m (7.9 ft)
Front brake	Internal expanding
Rear brake	Internal expanding
Front tire size	AT20 x 7-8★
Rear tire size	AT22 x 10-8★

ELECTRICAL

Ignition type	Electronic Ignition (CDI)
Ignition timing	10° B.T.D.C. below 1 000 r/min and 30° B.T.D.C. above 5 000 r/min
Spark plug	NGK DPR7EA-9 or NIPPONDENSO X22ERP-U9
Battery	12V 32.4 kC (9 Ah)/10 HR
Generator	Flywheel magneto
Fuse	15A
Headlight	12V 45/45W
Taillight	12V 5W
Neutral indicator light	12V 3.4W
Reverse indicator light	12V 3.4W

CAPACITIES

Fuel tank including reserve	8.5 L (2.2/1.9 US/Imp gal)
reserve	1.1 L (0.3/0.2 US/Imp gal)
Engine oil, oil change	1 500 ml (1.6/1.3 US/Imp qt)
with filter change	1 700 ml (1.8/1.5 US/Imp qt)

SERVICE DATA**VALVE + GUIDE**

Unit: mm (in)

ITEM	STANDARD		LIMIT
Valve diam.	IN.	28 (1.1)	—
	EX.	25 (1.0)	—
Valve lift	IN.	7.1 (0.28)	—
	EX.	6.9 (0.27)	—
Valve clearance (when cold)	IN.	0.03–0.08 (0.001–0.003)	—
	EX.	0.05–0.10 (0.002–0.004)	—
Valve guide to valve stem clearance	IN.	0.010–0.037 (0.0004–0.0015)	—
	EX.	0.030–0.057 (0.0012–0.0022)	—
Valve stem deflection	IN. & EX.	—	0.35 (0.014)
Valve guide I.D.	IN. & EX.	5.500–5.512 (0.2165–0.2170)	—
Valve stem O.D.	IN.	5.475–5.490 (0.2155–0.2161)	—
	EX.	5.455–5.470 (0.2148–0.2153)	—
Valve stem runout	IN. & EX.	—	0.05 (0.002)
Valve head thickness	IN. & EX.	—	0.5 (0.02)
Valve stem end length	IN. & EX.	—	2.5 (0.10)
Valve seat width	IN. & EX.	0.9–1.1 (0.035–0.043)	—
Valve head radial runout	IN. & EX.	—	0.03 (0.001)
Valve spring free length (IN. & EX.)	—		39.5 (1.56)
Valve spring tension (IN. & EX.)	18.4–21.6 kg (40.6–47.6 lbs) at length 36.8 mm (1.45 in)		—

CAMSHAFT + CYLINDER HEAD

Unit: mm (in)

ITEM	STANDARD		LIMIT	
Cam height	P-03	IN.	33.768–33.808 (1.3295–1.3310)	33.470 (1.3177)
		EX.	33.390–33.430 (1.3146–1.3161)	33.090 (1.3028)
	The others	IN.	33.490–33.530 (1.3185–1.3201)	33.190 (1.3067)
		EX.	33.353–33.393 (1.3131–1.3147)	33.060 (1.3016)

ITEM	STANDARD		LIMIT
Camshaft journal oil clearance	IN. & EX.	0.032–0.066 (0.0013–0.0026)	0.150 (0.0059)
Camshaft journal holder I.D.	IN. & EX.	22.012–22.025 (0.8666–0.8671)	—
Camshaft journal O.D.	IN. & EX.	21.959–21.980 (0.8645–0.8654)	—
Camshaft runout	IN. & EX.	—	0.10 (0.004)
Rocker arm I.D.	IN. & EX.	12.000–12.018 (0.4724–0.4731)	—
Rocker arm shaft O.D.	IN. & EX.	11.977–11.995 (0.4715–0.4722)	—
Cylinder head distortion	—		0.05 (0.002)
Cylinder head cover distortion	—		0.05 (0.002)

CYLINDER + PISTON + PISTON RING

Unit: mm (in)

ITEM	STANDARD		LIMIT	
Compression pressure	1 000–1 400 kPa (10–14 kg/cm ²) (142–199 psi)		800 kPa (8 kg/cm ²) (114 psi)	
Piston to cylinder clearance	0.030–0.040 (0.0012–0.0016)		0.120 (0.0047)	
Cylinder bore	58.000–58.015 (2.2835–2.2841)		58.100 (2.2874)	
Piston diam.	57.965–57.980 (2.2821–2.2827) Measure at 20 mm (0.8 in) from the skirt end.		57.880 (2.2787)	
Cylinder distortion	—		0.05 (0.002)	
Piston ring free end gap	1st	R	Approx. 5.8 (0.23)	4.7 (0.19)
	2nd	R	Approx. 7.4 (0.29)	6.0 (0.24)
Piston ring end gap	1st & 2nd		0.010–0.025 (0.004–0.010)	0.70 (0.028)
Piston ring to groove clearance	1st		—	0.180 (0.0071)
	2nd		—	0.150 (0.0059)
Piston ring groove width	1st & 2nd		1.21–1.23 (0.0476–0.0484)	—
	Oil		2.51–2.53 (0.0988–0.0996)	—
Piston ring thickness	1st & 2nd		1.17–1.19 (0.046–0.047)	—
Piston pin bore	14.002–14.008 (0.5513–0.5515)		14.030 (0.5524)	
Piston pin O.D.	13.996–14.000 (0.5510–0.5512)		13.980 (0.5504)	

CONROD + CRANKSHAFT

Unit: mm (in)

ITEM	STANDARD	LIMIT
Conrod small end I.D.	14.004–14.012 (0.5513–0.5517)	14.040 (0.5528)
Conrod deflection	—	3.0 (0.12)
Conrod big end side clearance	0.10–0.45 (0.0039–0.0177)	1.00 (0.039)
Conrod big end width	15.95–16.00 (0.628–0.630)	—
Crank web to web width	53.0±0.1 (2.087±0.004)	—
Crankshaft runout	—	0.05 (0.002)

OIL PUMP

ITEM	STANDARD	LIMIT
Oil pump reduction ratio	1.566 (47/30)	—
Oil pressure (at 60°C, 140°F)	Above 30 kPa (0.30 kg/cm ² , 4.3 psi) Below 70 kPa (0.70 kg/cm ² , 10.0 psi) at 3 000 r/min.	—

CLUTCH

Unit: mm (in)

ITEM	STANDARD	LIMIT
Clutch release screw	0–1/8 turn back	—
Drive plate thickness	2.7–2.9 (0.106–0.114)	2.4 (0.094)
Drive plate claw width	11.8–12.0 (0.46–0.47)	11.0 (0.43)
Driven plate distortion	—	0.10 (0.004)
Clutch spring free length	—	27.6 (1.09)
Clutch wheel I.D. (Clutch sleeve hub I.D.)	116 ^{+0.15} ₋₀ (4.566 ^{+0.006} ₋₀)	Scuffing or scratch on con- tacting surface
Clutch shoe	—	No groove at any part
Clutch engagement r/min.	2 200±200 r/min.	—
Clutch lock-up r/min.	3 500±250 r/min.	—

TRANSMISSION + DRIVE CHAIN

Unit: mm (in) Except ratio

ITEM	STANDARD	LIMIT
Primary reduction ratio	3.736 (71/19)	—
Final reduction ratio	P-51	4.090 (45/11)
	The others	3.545 (39/11)
Gear ratios	Low	3.166 (38/12)
	2nd	2.142 (30/14)
	3rd	1.588 (27/17)
	4th	1.200 (24/20)
	Top	0.950 (19/20)
	Reverse	2.833 (29/12 x 34/29)

ITEM	STANDARD		LIMIT
Shift fork to groove clearance	0.10–0.30 (0.004–0.012)		0.50 (0.020)
Shift fork to groove width	No.1, No.2 & No.3	4.50–4.60 (0.177–0.181)	—
	Reverse	4.00–4.10 (0.157–0.161)	—
Shift fork thickness	No.1, No.2 & No.3	4.30–4.40 (0.169–0.173)	—
	Reverse	3.80–3.90 (0.150–0.154)	—
Drive chain	Type	TAKASAGO: RK520SM	
	Links	P-51	88
		The others	84
	20-pitch length	—	
Drive chain slack	20–30 (0.8–1.2)		—
Gearshift lever height	10 (0.4)		—

CARBURETOR

ITEM	SPECIFICATION		
	P-03,24,28	P-51	P-33
Carburetor type	MIKUNI VM20SS	←	MIKUNI BS26SS
Bore size	20 mm	←	26 mm
I.D. No.	02C02	02C2	02C1
Idle r/min.	1 500 ± 50 r/min.	←	←
Float height	25.8 ± 1.0 mm (1.02 ± 0.04 in)	←	21.4 ± 1.0 mm (0.84 ± 0.04 in)
Main jet (M.J.)	# 87.5	←	# 107.5
Jet needle (J.N.)	5FU96-3rd	←	4DN13
Needle jet (N.J.)	O-1	←	P-0M
Pilot jet (P.J.)	# 22.5	←	# 32.5
Starter jet (G.S.)	# 22.5	←	# 20
Pilot screw (P.S.)	1 5/8 turns back	←	PRE-SET
Throttle cable play	1–3 mm (0.04–0.12 in)	←	←
Starter cable play	0.5–1.0 mm (0.02–0.04 in)	←	←

ELECTRICAL

Unit: mm (in)

ITEM		SPECIFICATION		NOTE
Ignition timing		10° B.T.D.C. below 1 000 r/min. and 30° B.T.D.C. above 5 000 r/min.		
Spark plug		Type	NGK: DPR7EA-9 ND: X22EPR-U9	
		Gap	0.8–0.9 (0.031–0.035)	
Spark performance		Over 8 (0.3) at 1 atm.		
Ignition coil resistance		Primary	0.1–1.0 Ω	Terminal– Ground
		Secondary	10–25 kΩ	Plug cap– Ground
Magneto coil resistance		Primary	350–550 Ω	Br–B/W
		Pulser	200–400 Ω	Bl–G
		Charging	0.6–1.0 Ω	Y–Y
Generator no-load voltage		More than 55 V (AC) at 5 000 r/min.		
Generator Max. output		Approx. 150 W at 5 000 r/min.		
Regulated voltage		13.5–15.5 V at 5 000 r/min.		
Starter motor brush length commutator under-cut		Limit:	9 (0.35)	MITSUBA
		Limit:	0.2 (0.008)	
Starter relay resistance		3–7 Ω		
Battery	Type designation	YB9A-A		
	Capacity	12 V 32.4 kC (9 Ah)/10 HR		
	Standard electrolyte S.G.	1.28 at 20°C (68°F)		
Fuse size		15 A		

WATTAGE

Unit:W

ITEM		SPECIFICATION
Headlight	HI	45
	LO	45
Taillight		5
Reverse indicator light		3.4
Neutral indicator light		3.4

BRAKE + WHEEL

Unit: mm (in)

ITEM	STANDARD		LIMIT
Front brake lever free travel	30 (1.2)		—
Rear brake pedal free travel	20–30 (0.8–1.2)		—
Brake drum I.D.	Front	—	120.7 (4.75)
	Rear	—	150.7 (5.93)
Brake lining thickness	—		1.5 (0.06)
Steering angle	Inside	41°	—
	Outside	30°	—
Turning radius	2.4 m (7.9 ft)		—
Toe-in (with 75 kg, 165 lbs)	3–11 (0.1–0.4)		—
Caster	8°		—
Trail	31 (1.2)		—
Wheel axle runout	Rear	—	8.0 (0.31)
Wheel rim size	Front	8 x 5.5 AT	—
	Rear	8 x 8.0 AT	—
Tire size	Front	AT 20 x 7-8☆	—
	Rear	AT 22 x 10-8☆	—
Tire tread depth	Front	4.0 (0.16)	—
	Rear	4.0 (0.16)	—

SUSPENSION

Unit: mm (in)

ITEM	STANDARD	LIMIT	NOTE
Rear shock absorber spring setting	2nd position	—	
Front wheel travel	80 (3.1)	—	
Rear wheel travel	90 (3.5)	—	
Swingarm pivot shaft runout	—	0.6 (0.02)	

TIRE PRESSURE

COLD INFLATION TIRE PRESSURE	LOAD CAPACITY		
	130 kg (285 lbs)		
	kPa	kg/cm ²	psi
FRONT	25	0.25	3.6
REAR	20	0.20	2.9

FUEL + OIL

ITEM	SPECIFICATION		NOTE
Fuel type	Use only unleaded gasoline of at least 85 pump octane ($\frac{R+M}{2}$) or 91 octane or higher rated by the research method. Gasoline containing MTBE (Methyl Tertiary Butyl Ether), less than 10% ethanol, or less than 5% methanol with appropriate cosolvents and corrosion inhibitor is permissible.		P-03,33
	Use only unleaded gasoline of at least 87 pump octane ($\frac{R+M}{2}$ method) or 91 octane or higher rated by the Research Method.		P-28
	Gasoline used should be graded 85–95 octane or higher. An unleaded gasoline is recommended.		The others
Fuel tank including reserve	8.5 L (2.2/1.9 US/Imp gal)		
reserve	1.1 L (0.3/0.2 US/Imp gal)		
Engine oil type	SAE 10W/40, API, SF or SG		
Engine oil capacity	Change	1 500 ml (1.6/1.3 US/Imp qt)	
	Filter change	1 700 ml (1.8/1.5 US/Imp qt)	
	Overhaul	1 900 ml (2.0/1.8 US/Imp qt)	

LT-F160Y/K1/K2 ('00, '01, '02-MODELS)

This section describes service data, service specifications and servicing procedures which differ from those of the LT-F160X ('99-MODEL).

- *Any differences in service data and service specifications with those that apply to the LT-F160Y/K1/K2 models are clearly indicated with an asterisk (*).*
- *Please refer to the sections 1 through 13 for details which are not given in this section.*

CONTENTS

SPECIFICATIONS	14- 1
SERVICE DATA	14- 3
IGNITION SYSTEM (Y-MODEL)	14-11
WIRING DIAGRAM (Y-MODEL).....	14-12
IGNITION SYSTEM (FROM K1-MODEL)	14-13
WIRING DIAGRAM (FROM K1-MODEL).....	14-14

SPECIFICATIONS

DIMENSIONS AND DRY MASS

Overall length	1 670 mm (65.7 in)
Overall width	985 mm (38.8 in)
Overall height	1 000 mm (39.4 in)
Wheelbase	1 070 mm (42.1 in)
Ground clearance	135 mm (5.3 in)
Front track	730 mm (28.7 in)
Rear track	730 mm (28.7 in)
Seat height	725 mm (28.5 in)
Dry mass	162 kg (357 lbs)

ENGINE

Type	Four-stroke, air-cooled, OHC
Number of cylinders	1
Bore	58.0 mm (2.283 in)
Stroke	60.0 mm (2.362 in)
Displacement	158 cm ³ (9.6 cu. in)
Compression ratio	9.2 : 1
Carburetor	VM20SS, single [BS26, single (P-33)]
Air cleaner	Polyurethane foam element
Starter system	Electric
Lubrication system	Wet sump
Idle speed	1 450 – 1 550 r/min

TRANSMISSION

Clutch	Wet multi-plate type, automatic, centrifugal type
Transmission	5-forward constant mesh and 1-reverse
Gearshift pattern, forward	All up, foot lever operated
Gearshift pattern, reverse	Hand lever operated
Primary reduction ratio	3.736 (71/19)
Gear ratios, Low	3.166 (38/12)
2nd	2.142 (30/14)
3rd	1.588 (27/17)
4th	1.200 (24/20)
Top	0.950 (19/20)
Reverse	2.833 (34/12)
Final reduction ratio	3.545 (39/11)
Drive chain	RK520SM, 84 links

CHASSIS

Front suspension	Independent, swing axle, coil spring, oil damped
Rear suspension	Swinging arm, coil spring, oil damped, spring pre-load 5-way adjustable
Caster	8°
Trail	31 mm (1.2 in)
Toe-in	7 mm (0.28 in)
Camber	1° 40'
Steering angle	42°
Turning radius	2.4 m (7.9 ft)
Front brake	Drum brake
Rear brake	Drum brake
Front tire size	AT20 × 7-8 ☆
Rear tire size	AT22 × 10-8 ☆

ELECTRICAL

Ignition type	Electronic ignition (CDI)
Ignition timing	10° B.T.D.C. at 1 500 r/min
Spark plug	NGK DPR7EA-9 or DENSO X22EPR-U9
Battery	12V 32.4 kC (9 Ah)/10HR
Generator	Three-phase A.C. generator
Fuse	15A
Headlight	12V 45/45W
Taillight	12V 5W
Neutral indicator light	12V 3.4W
Reverse indicator light	12V 3.4W

CAPACITIES

Fuel tank, including reserve	8.5 L (2.2/1.9 US/Imp gal)
reserve	1.1 L (0.3/0.2 US/Imp gal)
Engine oil, oil change	1 500 ml (1.6/1.3 US/Imp qt)
with filter change	1 700 ml (1.8/1.5 US/Imp qt)

SERVICE DATA**VALVE + GUIDE**

Unit: mm (in)

ITEM	STANDARD		LIMIT
Valve diam.	IN.	28 (1.1)	—
	EX.	25 (1.0)	—
Valve clearance (when cold)	IN.	0.03 – 0.08 (0.001 – 0.003)	—
	EX.	0.05 – 0.10 (0.002 – 0.004)	—
Valve guide to valve stem clearance	IN.	0.010 – 0.037 (0.0004 – 0.0015)	—
	EX.	0.030 – 0.057 (0.0012 – 0.0022)	—
Valve stem deflection	IN. & EX.	—	0.35 (0.014)
Valve guide I.D.	IN. & EX.	5.500 – 5.512 (0.2165 – 0.2170)	—
Valve stem O.D.	IN.	5.475 – 5.490 (0.2155 – 0.2161)	—
	EX.	5.455 – 5.470 (0.2148 – 0.2153)	—
Valve stem runout	IN. & EX.	—	0.05 (0.002)
Valve head thickness	IN. & EX.	—	0.5 (0.02)
Valve stem end length	IN. & EX.	—	2.5 (0.10)
Valve seat width	IN. & EX.	0.9 – 1.1 (0.035 – 0.043)	—
Valve head radial runout	IN. & EX.	—	0.03 (0.001)
Valve spring free length (IN. & EX.)	—		39.5 (1.56)
Valve spring tension (IN. & EX.)	18.4 – 21.6 kg (40.6 – 47.6 lbs) at length 36.8 mm (1.45 in)		—

CAMSHAFT + CYLINDER HEAD

Unit: mm (in)

ITEM	STANDARD		LIMIT	
Cam height	P-03	IN.	33.768 – 33.808 (1.3295 – 1.3310)	33.470 (1.3177)
		EX.	33.390 – 33.430 (1.3146 – 1.3161)	33.090 (1.3028)
	The others	IN.	33.490 – 33.530 (1.3185 – 1.3201)	33.190 (1.3067)
		EX.	33.353 – 33.393 (1.3131 – 1.3147)	33.060 (1.3016)

ITEM	STANDARD		LIMIT
Camshaft journal oil clearance	IN. & EX.	0.032 – 0.066 (0.0013 – 0.0026)	0.150 (0.0059)
Camshaft journal holder I.D.	IN. & EX.	22.012 – 22.025 (0.8666 – 0.8671)	—
Camshaft journal O.D.	IN. & EX.	21.959 – 21.980 (0.8645 – 0.8654)	—
Camshaft runout	IN. & EX.	—	0.10 (0.004)
Rocker arm I.D.	IN. & EX.	12.000 – 12.018 (0.4724 – 0.4731)	—
Rocker arm shaft O.D.	IN. & EX.	11.977 – 11.995 (0.4715 – 0.4722)	—
Cylinder head distortion	—		0.05 (0.002)
Cylinder head cover distortion	—		0.05 (0.002)

CYLINDER + PISTON + PISTON RING

Unit: mm (in)

ITEM	STANDARD		LIMIT
Compression pressure	1 000 – 1 400 kPa (10 – 14 kg/cm ²) (142 – 199 psi)		800 kPa (8 kg/cm ²) (114 psi)
Piston to cylinder clearance	0.030 – 0.040 (0.0012 – 0.0016)		0.120 (0.0047)
Cylinder bore	58.000-58.015 (2.2835 – 2.2841)		58.100 (2.2874)
Piston diam.	57.965 – 57.980 (2.2821 – 2.2827) Measure at 20 mm (0.8 in) from the skirt end.		57.880 (2.2787)
Cylinder distortion	—		0.05 (0.002)
Piston ring free end gap	1st	R	Approx. 5.8 (0.23)
	2nd	R	Approx. 7.4 (0.29)
Piston ring end gap	1st & 2nd		0.010 – 0.025 (0.004 – 0.010)
Piston ring to groove clearance	1st		—
	2nd		—
Piston ring groove width	1st & 2nd		1.21 – 1.23 (0.0476 – 0.0484)
	Oil		2.51 – 2.53 (0.0988 – 0.0996)
Piston ring thickness	1st & 2nd		1.17 – 1.19 (0.046 – 0.047)
Piston pin bore	14.002 – 14.008 (0.5513 – 0.5515)		14.030 (0.5524)
Piston pin O.D.	13.996 – 14.000 (0.5510 – 0.5512)		13.980 (0.5504)

CONROD + CRANKSHAFT

Unit: mm (in)

ITEM	STANDARD	LIMIT
Conrod small end I.D.	14.004 – 14.012 (0.5513 – 0.5517)	14.040 (0.5528)
Conrod deflection	————	3.0 (0.12)
Conrod big end side clearance	0.10 – 0.45 (0.0039 – 0.0177)	1.00 (0.039)
Conrod big end width	15.95 – 16.00 (0.628 – 0.630)	————
Crank web to web width	53.0 ± 0.1 (2.087 ± 0.004)	————
Crankshaft runout	————	0.05 (0.002)

OIL PUMP

ITEM	STANDARD	LIMIT
Oil pressure (at 60°C, 140°F)	Above 30 kPa (0.30 kg/cm ² , 4.3 psi) Below 70 kPa (0.70 kg/cm ² , 10.0 psi) at 3 000 r/min.	————

CLUTCH

Unit: mm (in)

ITEM	STANDARD	LIMIT
Clutch release screw	0 – 1/8 turn back	————
Drive plate thickness	2.7 – 2.9 (0.106 – 0.114)	2.4 (0.094)
Drive plate claw width	11.8 – 12.0 (0.46 – 0.47)	11.0 (0.43)
Driven plate distortion	————	0.10 (0.004)
Clutch spring free length	————	27.6 (1.09)
Clutch shoe	————	No groove at any parts
Clutch engagement	2 200 ± 200 r/min.	————
Clutch lock-up	3 500 ± 250 r/min.	————

TRANSMISSION + DRIVE CHAIN

Unit: mm (in) Except ratio

ITEM	STANDARD	LIMIT
Primary reduction ratio	3.736 (71/19)	————
Final reduction ratio	P-51	4.090 (45/11)
	The others	3.545 (39/11)
Gear ratios	Low	3.166 (38/12)
	2nd	2.142 (30/14)
	3rd	1.588 (27/17)
	4th	1.200 (24/20)
	Top	0.950 (19/20)
	Reverse	2.833 (29/12 × 34/29)

ITEM	STANDARD		LIMIT
Shift fork to groove clearance	0.10 – 0.30 (0.004 – 0.012)		0.50 (0.020)
Shift fork to groove width	No.1, No.2 & No.3	4.50 – 4.60 (0.177 – 0.181)	—
	Reverse	4.00 – 4.10 (0.157 – 0.161)	—
Shift fork thickness	No.1, No.2 & No.3	4.30 – 4.40 (0.169 – 0.173)	—
	Reverse	3.80 – 3.90 (0.150 – 0.154)	—
Drive chain	Type	TAKASAGO: RK520SM	
	Links	P-51	88
		The others	84
	20-pitch length	—	
Drive chain slack	20 – 30 (0.8 – 1.2)		—
Gearshift lever height	10 (0.4)		—

CARBURETOR

ITEM	SPECIFICATION		
	P-03, 24, 28	P-51	P-33
Carburetor type	MIKUNI VM20SS	←	MIKUNI BS26SS
Bore size	20 mm	←	26 mm
I.D. No.	02C02	02C2	02C1
Idle r/min.	1 500 ± 50 r/min.	←	←
Float height	25.8 ± 1.0 mm (1.02 ± 0.04 in)	←	21.4 ± 1.0 mm (0.84 ± 0.04 in)
Main jet (M.J.)	#87.5	←	# 107.5
Jet needle (J.N.)	5FU96-3rd	←	4DN13
Needle jet (N.J.)	O-1	←	P-DM
Pilot jet (P.J.)	#22.5	←	# 32.5
Starter jet (G.S.)	#22.5	←	#20
Pilot screw (P.S.)	1 ⁵ / ₈ turns back	←	PRE-SET
Throttle cable play	3 – 5 mm (0.12 – 0.20 in)	←	←
Starter cable play	0.5 – 1.0 mm (0.02 – 0.04 in)	←	←

ELECTRICAL

Unit: mm (in)

ITEM		SPECIFICATION		NOTE
Spark plug		Type	NGK: DPR7EA-9 ND: X22EPR-U9	
		Gap	0.8 – 0.9 (0.031 – 0.035)	
Spark performance		Over 8 (0.3) at 1 atm.		
Ignition coil resistance		Primary	0.1 – 1.0 Ω	Terminal – Ground
		Secondary	10 – 25 kΩ	Plug cap – Ground
Magneto coil resistance		Pulser	*380 – 600 Ω	BI – G
		Charging	*0.5 – 1.2 Ω	Y – Y
Generator no-load voltage		More than 55 V (AC) at 5 000 r/min.		
Generator Max. output		Approx. 150 W at 5 000 r/min.		
Regulated voltage		13.5 – 15.5 V at 5 000 r/min.		
Starter relay resistance		3 – 7 Ω		
Battery	Type designation	YB9A-A		
	Capacity	12 V 32.4 kC (9 Ah)/10 HR		
	Standard electrolyte S.G.	1.28 at 20°C (68°F)		
Fuse size		15 A		

WATTAGE

Unit:W

ITEM		SPECIFICATION
Headlight	HI	45
	LO	45
Taillight		5
Reverse indicator light		3.4
Neutral indicator light		3.4

BRAKE + WHEEL

Unit: mm (in)

ITEM	STANDARD		LIMIT
Front brake lever free travel	30 (1.2)		—
Rear brake pedal free travel	20 – 30 (0.8 – 1.2)		—
Brake drum I.D.	Front	—	120.7 (4.75)
	Rear	—	150.7 (5.93)
Brake lining thickness	—		1.5 (0.06)
Steering angle	Inside	41°	—
	Outside	30°	—
Turning radius	2.4 m (7.9 ft)		—
Toe-in (with 75 kg, 165 lbs)	3 – 11 (0.1 – 0.4)		—
Caster	8°		—
Trail	31 (1.2)		—
Wheel axle runout	Rear	—	8.0 (0.31)
Wheel rim size	Front	8 × 5.5 AT	—
	Rear	8 × 8.0 AT	—
Tire size	Front	AT 20 × 7-8 ☆	—
	Rear	AT 22 × 10-8 ☆	—
Tire tread depth	Front	4.0 (0.16)	—
	Rear	4.0 (0.16)	—

SUSPENSION

Unit: mm (in)

ITEM	STANDARD	LIMIT	NOTE
Rear shock absorber spring setting	2nd position	—	
Front wheel travel	80 (3.1)	—	
Rear wheel travel	90 (3.5)	—	
Swingarm pivot shaft runout	—	0.6 (0.02)	

TIRE PRESSURE

COLD INFLATION TIRE PRESSURE	LOAD CAPACITY		
	130 kg (285 lbs)		
	kPa	kg/cm ²	psi
FRONT	25	0.25	3.6
REAR	20	0.20	2.9

FUEL + OIL

ITEM	SPECIFICATION		NOTE
Fuel type	Use only unleaded gasoline of at least 87 pump octane ($\frac{R+M}{2}$) or 91 octane or higher rated by the research method. Gasoline containing MTBE (Methyl Tertiary Butyl Ether), less than 10% ethanol, or less than 5% methanol with appropriate cosolvents and corrosion inhibitor is permissible.		P-03, 28, 33
	Gasoline used should be graded 91 octane or higher. An unleaded gasoline is recommended.		P-24, 51
Fuel tank including reserve	8.5 L (2.2/1.9 US/Imp gal)		
reserve	1.1 L (0.3/0.2 US/Imp gal)		
Engine oil type	SAE 10W/40, API, SF or SG		
Engine oil capacity	Change	1 500 ml (1.6/1.3 US/Imp qt)	
	Filter change	1 700 ml (1.8/1.5 US/Imp qt)	
	Overhaul	1 900 ml (2.0/1.8 US/Imp qt)	

IGNITION SYSTEM (Y-MODEL)

DESCRIPTION

In the capacitor discharged ignition system, the battery's electrical energy charges the capacitor. This energy is released in a single surge at the specified ignition timing point, and current flows through the primary side of the ignition coil. A high voltage current is induced in the secondary windings of the ignition coil, resulting in strong spark between the spark plug gap.

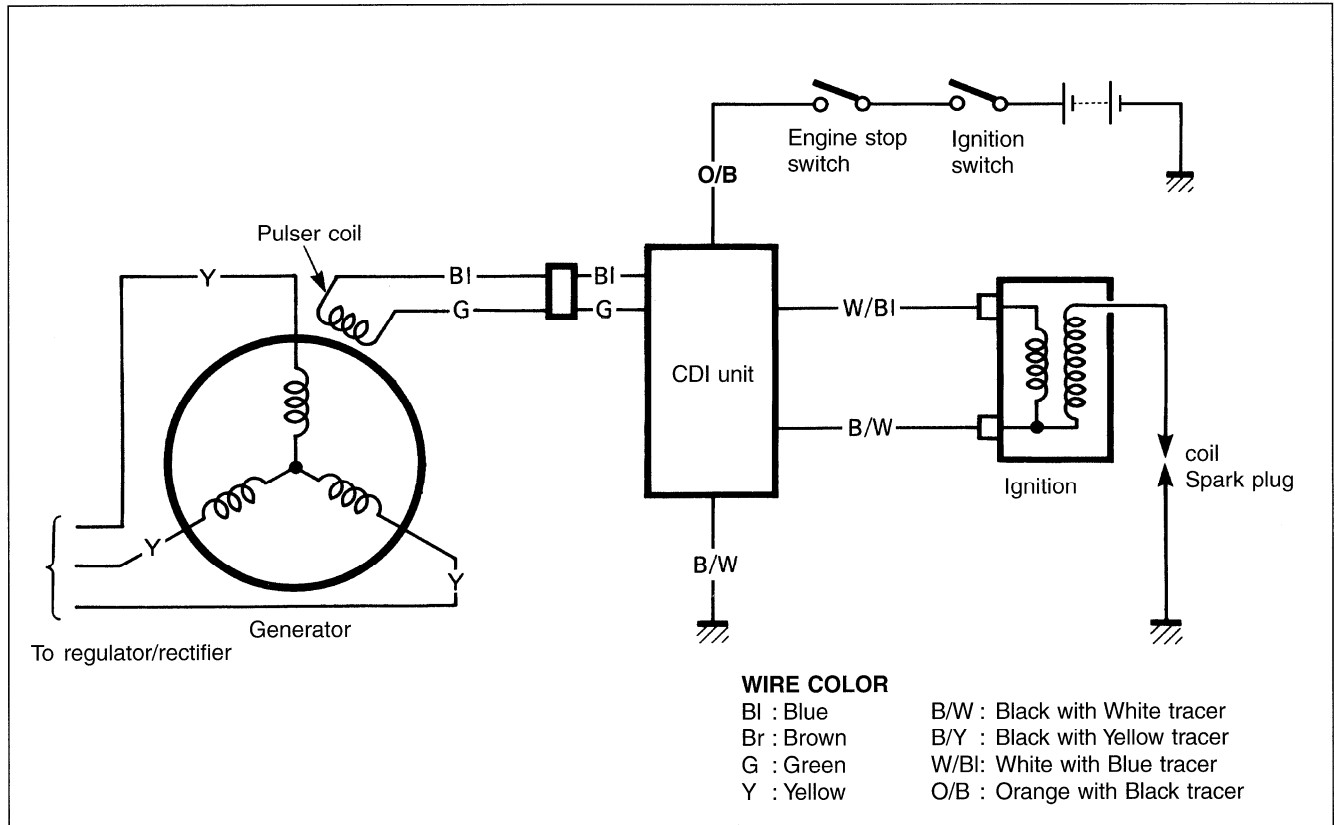

INSPECTION

MAGNETO COIL

- Remove the rear fender. (☞ 6-3)
- Disconnect the pulser coil lead wires.
- Using the pocket tester, measure the resistance between the lead wires in the following table.

Tester knob indication: Resistance (Ω)

DATA Magneto coil resistance

Pulser coil (BI – G): 380 – 600 Ω

NOTE:

When replacing the stator, apply a small quantity of **THREAD LOCK "1342"** to the threaded parts of stator screws.

1342 99000-32050: Thread Lock "1342"

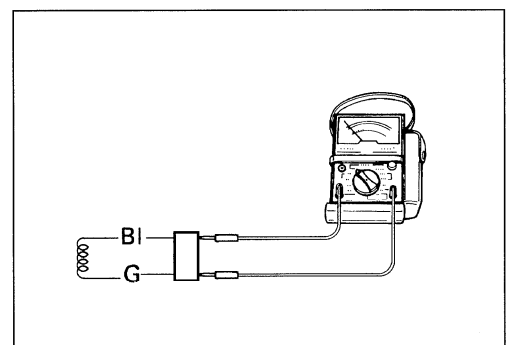

IGNITION COIL

- Remove the front fender. (☞ 6-1)
- Remove the ignition coil from the frame.
- Measure the ignition coil resistance in both the primary and secondary windings. If the windings are in sound condition, their resistance should be close to the specified values.

 **Tester knob indication: Resistance (Ω)**

DATA Ignition coil resistance

Primary (Terminal – Ground): 0.1 – 1.0 Ω

Secondary (Plug cap – Ground): 10 – 25 kΩ

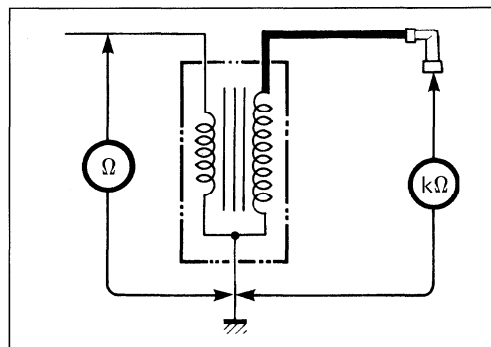

CDI UNIT

- Remove the front fender cover. (☞ 6-1)
- Remove the CDI unit from the frame.
- Measure the voltage between the terminals in the following table.

TOOL 09900-25008: Multi circuit tester set

 **Tester knob indication: Diode test (+←)**

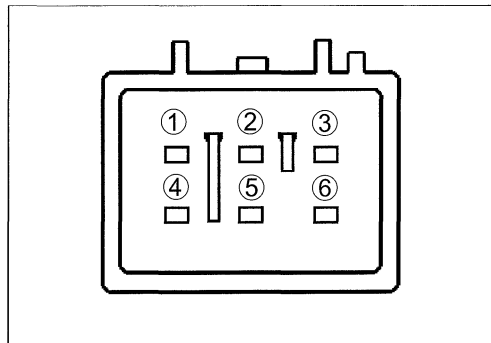

Unit: V

		⊕ Probe of tester to:					
		①	②	③	④	⑤	⑥
⊖ Probe of tester to:	①		1.5	1.5	1.5	1.5	1.5
	②	1.5		1.5	1.5	1.5	1.5
	③	1.33	1.5		1.23	1.11	1.23
	④	1.46	1.5	1.45		1.44	1.45
	⑤	0.96	1.5	1.07	0.49		0.51
	⑥	1	1.5	1.32	1.28	1.09	

WIRING DIAGRAM (Y-MODEL)

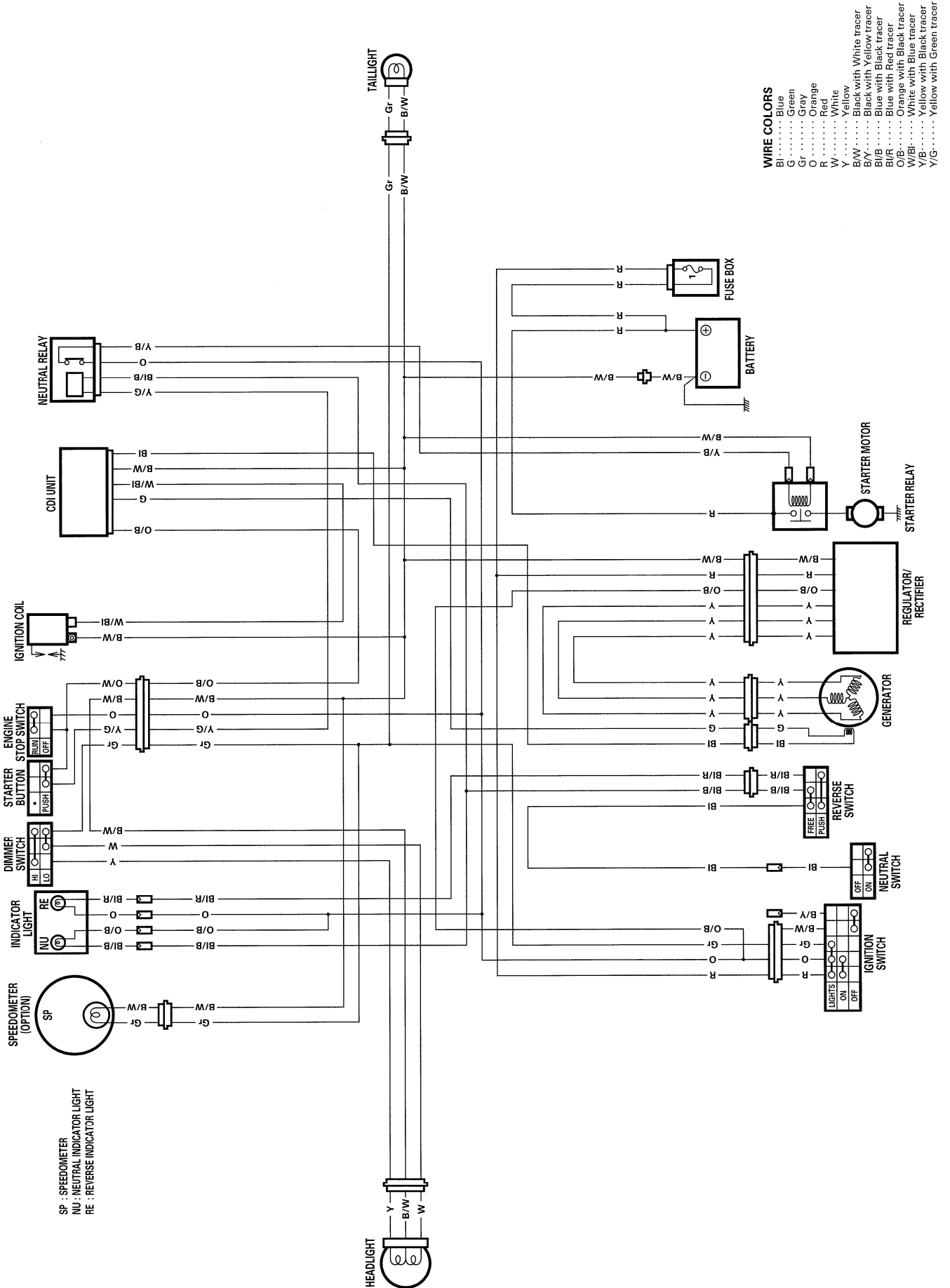

IGNITION SYSTEM (FROM K1-MODEL)

INSPECTION

CDI UNIT

- Remove the front fender cover. (👉 6-1)
- Remove the CDI unit from the frame.
- Measure the voltage between the terminals in the following table.

 **09900-25008: Multi circuit tester set**

 **Tester knob indication: Diode test (←→)**

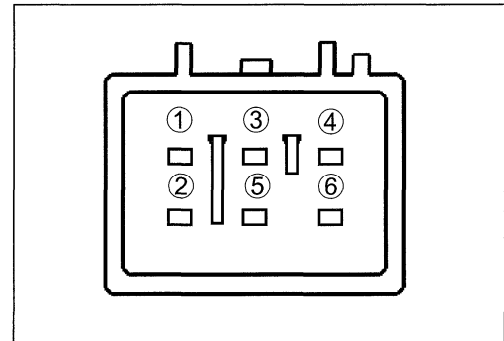

Unit: V

		⊕ Probe of tester to:					
		①	②	③	④	⑤	⑥
① Probe of tester to:	①		Approx. 1.5	Approx. 1.5	Approx. 1.5	Approx. 1.5	Approx. 1.5
	②	Approx. 1.2		Approx. 1.4	Approx. 1.3	Approx. 1.2	Approx. 1.1
	③	Approx. 1.3	Approx. 1.5		Approx. 1.2	Approx. 1.1	Approx. 1.2
	④	Approx. 1.4	Approx. 1.5	Approx. 1.4		Approx. 1.4	Approx. 1.4
	⑤	Approx. 0.9	Approx. 1.5	Approx. 1.1	Approx. 0.5		Approx. 0.5
	⑥	Approx. 1.0	Approx. 1.5	Approx. 1.3	Approx. 1.2	Approx. 1.1	

WIRING DIAGRAM (FROM K1-MODEL)

WIRE COLORS

Bl	Blue
G	Green
Gr	Gray
O	Orange
R	Red
W	White
Y	Yellow
B/W	Black with White tracer
B/Y	Black with Yellow tracer
B/B	Black with Black tracer
B/R	Blue with Red tracer
O/B	Orange with Black tracer
W/Bl	White with Blue tracer
Y/B	Yellow with Black tracer
Y/G	Yellow with Green tracer

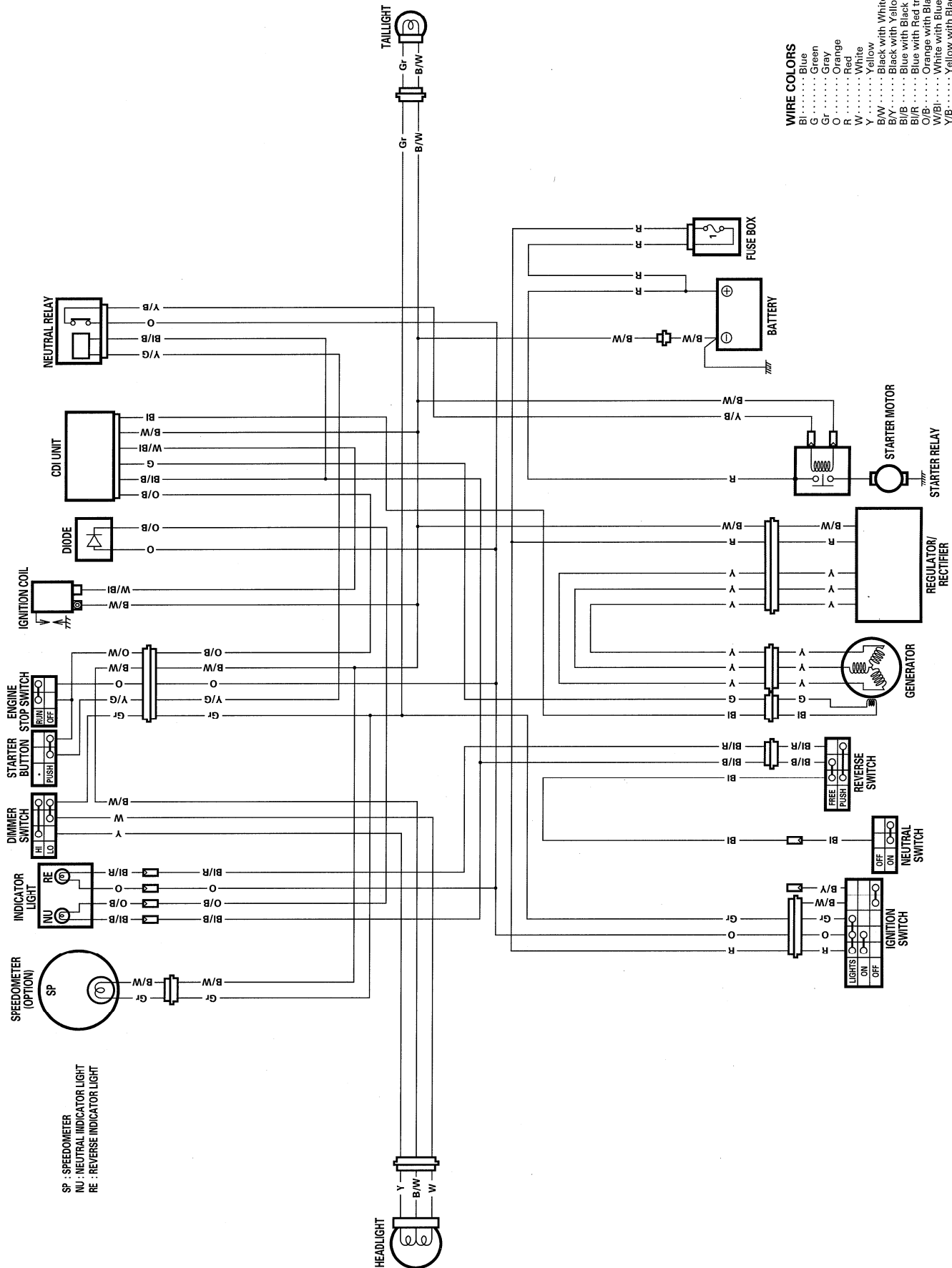

LT160K3/K4 ('03, '04-MODELS) LT-F160K3/K4/K5 ('03, '04, '05-MODELS)

This section describes service data, service specifications and servicing procedures which differ from those of the LT-F160K2 ('02-MODEL).

- Any differences in service data and service specifications with those that apply to the LT160K3/K4, LT-F160K3/K4/K5 models are clearly indicated with an asterisk (*).
- Please refer to the sections 1 through 14 for details which are not given in this section.

CONTENTS

SPECIFICATIONS	15- 1
LT160	15- 1
LT-F160	15- 3
SERVICE DATA	15- 5
LT160	15- 5
LT-F160	15-12
WIRING DIAGRAM	15-19

SPECIFICATIONS

LT160

DIMENSIONS AND DRY MASS

Overall length	* 1 610 mm (63.4 in)
Overall width	985 mm (38.8 in)
Overall height	1 000 mm (39.4 in)
Wheelbase	1 070 mm (42.1 in)
Ground clearance	135 mm (5.3 in)
Front track	730 mm (28.7 in)
Rear track	730 mm (28.7 in)
Seat height.....	725 mm (28.5 in)
Dry mass.....	* 155 kg (341 lbs)

ENGINE

Type	Four-stroke, air-cooled, OHC
Number of cylinders	1
Bore	58.0 mm (2.283 in)
Stroke.....	60.0 mm (2.362 in)
Displacement	158 cm ³ (9.6 cu. in)
Compression ratio.....	9.2 : 1
Carburetor.....	MIKUNI VM20SS, single..... P-03 * MIKUNI BS26SS, single P-33
Air cleaner.....	Polyurethane foam element
Starter system.....	Electric
Lubrication system	Wet sump
Idle speed	1 500 ± 100 r/min

DRIVE TRAIN

Clutch.....	Wet multi-plate type, automatic, centrifugal type
Transmission	5-forward constant mesh and 1-reverse
Gearshift pattern, forward	All up, foot lever operated
Gearshift pattern, reverse	Hand lever operated
Primary reduction ratio.....	3.736 (71/19)
Gear ratios, Low	3.166 (38/12)
2nd	2.142 (30/14)
3rd.....	1.588 (27/17)
4th	1.200 (24/20)
Top	0.950 (19/20)
Reverse.....	2.833 (34/12)
Final reduction ratio	3.545 (39/11)
Drive chain	RK520SM, 84 links

CHASSIS

Front suspension	Independent, swing axle, coil spring, oil damped
Rear suspension	Swinging arm, coil spring, oil damped
Caster	8°
Trail	31 mm (1.2 in)
Toe-in	7 mm (0.28 in)
Camber	1° 40'
Steering angle	42°
Turning radius	2.4 m (7.9 ft)
Front brake	Drum brake
Rear brake	Drum brake
Front tire size	AT20 × 7-8★
Rear tire size	AT22 × 10-8★

ELECTRICAL

Ignition type	Electronic ignition (CDI)
Ignition timing	10° B.T.D.C. at 1 500 rpm
Spark plug	NGK DPR7EA-9 or DENSO X22EPR-U9
Battery	12V 32.4 kC (9 Ah)/10HR
Generator	Three-phase A.C. generator
Fuse	15A
Headlight	12V 45/45W
Brake light/Taillight	* 12V 21/5W
Neutral indicator light	12V 3.4W
Reverse indicator light	12V 3.4W

CAPACITIES

Fuel tank, including reserve	8.5 L (2.2/1.9 US/Imp gal)
reserve	1.1 L (0.3/0.2 US/Imp gal)
Engine oil, oil change	1 500 ml (1.6/1.3 US/Imp qt)
with filter change	1 700 ml (1.8/1.5 US/Imp qt)
Over haul	1 800 ml (1.9/1.6 US/Imp qt)

LT-F160**DIMENSIONS AND DRY MASS**

Overall length	1 670 mm (65.7 in)
Overall width	985 mm (38.8 in)
Overall height	1 000 mm (39.4 in)
Wheelbase	1 070 mm (42.1 in)
Ground clearance	135 mm (5.3 in)
Front track	730 mm (28.7 in)
Rear track	730 mm (28.7 in)
Seat height	725 mm (28.5 in)
Dry mass	162 kg (357 lbs)

ENGINE

Type	Four-stroke, air-cooled, OHC
Number of cylinders	1
Bore	58.0 mm (2.283 in)
Stroke	60.0 mm (2.362 in)
Displacement	158 cm ³ (9.6 cu. in)
Compression ratio	9.2 : 1
Carburetor	MIKUNI VM20SS, single
Air cleaner	Polyurethane foam element
Starter system	Electric
Lubrication system	Wet sump
Idle speed	1 500 ± 100 r/min

DRIVE TRAIN

Clutch	Wet multi-plate type, automatic, centrifugal type
Transmission	5-forward constant mesh and 1-reverse
Gearshift pattern, forward	All up, foot lever operated
Gearshift pattern, reverse	Hand lever operated
Primary reduction ratio	3.736 (71/19)
Gear ratios, Low	3.166 (38/12)
2nd	2.142 (30/14)
3rd	1.588 (27/17)
4th	1.200 (24/20)
Top	0.950 (19/20)
Reverse	2.833 (34/12)
Final reduction ratio	* 4.090 (45/11) P-51 3.545 (39/11) Others
Drive chain	* RK520SM, 88 links P-51 RK520SM, 84 links Others

CHASSIS

Front suspension	Independent, swing axle, coil spring, oil damped
Rear suspension	Swinging arm, coil spring, oil damped
Caster	8°
Trail	31 mm (1.2 in)
Toe-in	7 mm (0.28 in)
Camber	1° 40'
Steering angle	42°
Turning radius	2.4 m (7.9 ft)
Front brake	Drum brake
Rear brake	Drum brake
Front tire size	AT20 × 7-8★
Rear tire size	AT22 × 10-8★

ELECTRICAL

Ignition type	Electronic ignition (CDI)
Ignition timing	10° B.T.D.C. at 1 500 rpm
Spark plug	NGK DPR7EA-9 or DENSO X22EPR-U9
Battery	12V 32.4 kC (9 Ah)/10HR
Generator	Three-phase A.C. generator
Fuse	15A
Headlight	12V 45/45W
Brake light/Taillight	* 12V 21/5W
Neutral indicator light	12V 3.4W
Reverse indicator light	12V 3.4W

CAPACITIES

Fuel tank, including reserve	8.5 L (2.2/1.9 US/Imp gal)
reserve	1.1 L (0.3/0.2 US/Imp gal)
Engine oil, oil change	1 500 ml (1.6/1.3 US/Imp qt)
with filter change	1 700 ml (1.8/1.5 US/Imp qt)
Over haul	1 800 ml (1.9/1.6 US/Imp qt)

SERVICE DATA**LT160****VALVE + GUIDE**

Unit: mm (in)

ITEM	STANDARD		LIMIT
Valve diam.	IN.	28 (1.1)	—
	EX.	25 (1.0)	—
Valve clearance (when cold)	IN.	0.03 – 0.08 (0.001 – 0.003)	—
	EX.	0.05 – 0.10 (0.002 – 0.004)	—
Valve guide to valve stem clearance	IN.	0.010 – 0.037 (0.0004 – 0.0015)	—
	EX.	0.030 – 0.057 (0.0012 – 0.0022)	—
Valve stem deflection	IN. & EX.	—	0.35 (0.014)
Valve guide I.D.	IN. & EX.	5.500 – 5.512 (0.2165 – 0.2170)	—
Valve stem O.D.	IN.	5.475 – 5.490 (0.2155 – 0.2161)	—
	EX.	5.455 – 5.470 (0.2148 – 0.2153)	—
Valve stem runout	IN. & EX.	—	0.05 (0.002)
Valve head thickness	IN. & EX.	—	0.5 (0.02)
Valve stem end length	IN. & EX.	—	2.5 (0.10)
Valve seat width	IN. & EX.	0.9 – 1.1 (0.035 – 0.043)	—
Valve head radial runout	IN. & EX.	—	0.03 (0.001)
Valve spring free length (IN. & EX.)	—		39.5 (1.56)
Valve spring tension (IN. & EX.)	18.4 – 21.6 kg (40.6 – 47.6 lbs) at length 36.8 mm (1.45 in)		—

CAMSHAFT + CYLINDER HEAD

Unit: mm (in)

ITEM		STANDARD		LIMIT
Cam height	P-03	IN.	33.768 – 33.808 (1.3295 – 1.3310)	33.470 (1.3177)
		EX.	33.390 – 33.430 (1.3146 – 1.3161)	33.090 (1.3028)
	P-33	IN.	33.490 – 33.530 (1.3185 – 1.3201)	33.190 (1.3067)
		EX.	33.353 – 33.393 (1.3131 – 1.3147)	33.060 (1.3016)
Camshaft journal oil clearance		IN. & EX.	0.032 – 0.066 (0.0013 – 0.0026)	0.150 (0.0059)
Camshaft journal holder I.D.		IN. & EX.	22.012 – 22.025 (0.8666 – 0.8671)	—
Camshaft journal O.D.		IN. & EX.	21.959 – 21.980 (0.8645 – 0.8654)	—
Camshaft runout		IN. & EX	—	0.10 (0.004)
Rocker arm I.D.		IN. & EX	12.000 – 12.018 (0.4724 – 0.4731)	—
Rocker arm shaft O.D.		IN. & EX	11.977 – 11.995 (0.4715 – 0.4722)	—
Cylinder head distortion			—	0.05 (0.002)
Cylinder head cover distortion			—	0.05 (0.002)

CYLINDER + PISTON + PISTON RING

Unit: mm (in)

ITEM		STANDARD		LIMIT
Compression pressure		1 000 – 1 400 kPa (10 – 14 kgf/cm ² , 142 – 199 psi)		800 kPa (8 kgf/cm ² , 114 psi)
Piston to cylinder clearance		0.030 – 0.040 (0.0012 – 0.0016)		0.120 (0.0047)
Cylinder bore		58.000-58.015 (2.2835 – 2.2841)		58.100 (2.2874)
Piston diam.		57.965 – 57.980 (2.2821 – 2.2827) Measure at 20 mm (0.8 in) from the skirt end.		57.880 (2.2787)
Cylinder distortion		—		0.05 (0.002)
Piston ring free end gap	1st	R	Approx. 5.8 (0.23)	4.7 (0.19)
	2nd	R	Approx. 7.4 (0.29)	6.0 (0.24)
Piston ring end gap		1st & 2nd	0.010 – 0.025 (0.004 – 0.010)	0.70 (0.028)
Piston ring to groove clearance	1st	—		0.180 (0.0071)
	2nd	—		0.150 (0.0059)
Piston ring groove width	1st & 2nd	1.21 – 1.23 (0.0476 – 0.0484)		—
	Oil	2.51 – 2.53 (0.0988 – 0.0996)		—

ITEM	STANDARD		LIMIT
Piston ring thickness	1st & 2nd	1.17 – 1.19 (0.046 – 0.047)	—
Piston pin bore		14.002 – 14.008 (0.5513 – 0.5515)	14.030 (0.5524)
Piston pin O.D.		13.996 – 14.000 (0.5510 – 0.5512)	13.980 (0.5504)

CONROD + CRANKSHAFT

Unit: mm (in)

ITEM	STANDARD		LIMIT
Conrod small end I.D.		14.004 – 14.012 (0.5513 – 0.5517)	14.040 (0.5528)
Conrod deflection		—	3.0 (0.12)
Conrod big end side clearance		0.10 – 0.45 (0.0039 – 0.0177)	1.00 (0.039)
Conrod big end width		15.95 – 16.00 (0.628 – 0.630)	—
Crank web to web width		53.0 ± 0.1 (2.087 ± 0.004)	—
Crankshaft runout		—	0.05 (0.002)

OIL PUMP

ITEM	STANDARD	LIMIT
Oil pressure (at 60°C, 140°F)	Above 30 kPa (0.30 kgf/cm ² , 4.3 psi) Below 70 kPa (0.70 kgf/cm ² , 10.0 psi) at 3 000 r/min.	—

CLUTCH

Unit: mm (in)

ITEM	STANDARD	LIMIT
Clutch release screw	0 – 1/8 turn back	—
Drive plate thickness	2.7 – 2.9 (0.106 – 0.114)	2.4 (0.094)
Drive plate claw width	11.8 – 12.0 (0.46 – 0.47)	11.0 (0.43)
Driven plate distortion	—	0.10 (0.004)
Clutch spring free length	—	27.6 (1.09)
Clutch shoe	—	No groove at any parts
Clutch engagement	2 200 ± 200 r/min.	—
Clutch lock-up	3 500 ± 250 r/min.	—

DRIVE TRAIN

Unit: mm (in) Except ratio

ITEM		STANDARD		LIMIT
Primary reduction ratio		3.736 (71/19)		—
Final reduction ratio		3.545 (39/11)		—
Gear ratios	Low	3.166 (38/12)		—
	2nd	2.142 (30/14)		—
	3rd	1.588 (27/17)		—
	4th	1.200 (24/20)		—
	Top	0.950 (19/20)		—
	Reverse	2.833 (29/12 × 34/29)		—
Shift fork to groove clearance		0.10 – 0.30 (0.004 – 0.012)		0.50 (0.020)
Shift fork groove width	No.1, No.2 & No.3	4.50 – 4.60 (0.177 – 0.181)		—
	Reverse	4.00 – 4.10 (0.157 – 0.161)		—
Shift fork thickness	No.1, No.2 & No.3	4.30 – 4.40 (0.169 – 0.173)		—
	Reverse	3.80 – 3.90 (0.150 – 0.154)		—
Drive chain	Type	TAKASAGO: RK520SM		—
	Links	84		—
	20-pitch length	—		319.4 (12.57)
Drive chain slack		20 – 30 (0.8 – 1.2)		—
Gearshift lever height		10 (0.4)		—

CARBURETOR

ITEM	SPECIFICATION	
	P-03	P-33
Carburetor type	MIKUNI VM20SS	MIKUNI BS26SS
Bore size	20 mm	26 mm
I.D. No.	02C02	02C1
Idle r/min.	1 500 ± 100 r/min.	←
Float height	25.8 ± 1.0 mm (1.02 ± 0.04 in)	21.4 ± 1.0 mm (0.84 ± 0.04 in)
Main jet (M.J.)	#87.5	#107.5
Jet needle (J.N.)	5FU96-3rd	4DN13-1st
Needle jet (N.J.)	O-1	P-DM
Pilot jet (P.J.)	#22.5	#32.5
Starter jet (G.S.)	#22.5	#20
Pilot screw (P.S.)	1 ⁵ / ₈ turns back	PRE-SET
Throttle cable play	3 – 5 mm (0.12 – 0.20 in)	←
Starter cable play	0.5 – 1.0 mm (0.02 – 0.04 in)	←

ELECTRICAL

Unit: mm (in)

ITEM		SPECIFICATION		NOTE
Spark plug		Type	NGK: DPR7EA-9 ND: X22EPR-U9	
		Gap	0.8 – 0.9 (0.031 – 0.035)	
Spark performance		Over 8 (0.3) at 1 atm.		
Ignition coil resistance		Primary	0.1 – 1.0 Ω	Terminal – Ground
		Secondary	10 – 25 k Ω	Plug cap – Ground
Magneto coil resistance		Pulser	380 – 600 Ω	BI – G
		Charging	0.5 – 1.2 Ω	Y – Y
Generator no-load voltage		More than 55 V (AC) at 5 000 r/min.		
Generator Max. output		Approx. 150 W at 5 000 r/min.		
Regulated voltage		13.5 – 15.5 V at 5 000 r/min.		
Starter relay resistance		3 – 7 Ω		
Battery	Type designation	YB9A-A		
	Capacity	12 V 32.4 kC (9 Ah)/10 HR		
	Standard electrolyte S.G.	1.28 at 20°C (68°F)		
Fuse size		15 A		

WATTAGE

Unit: W

ITEM		SPECIFICATION
Headlight	HI	45
	LO	45
Brake light/Taillight		*21/5
Reverse indicator light		3.4
Neutral indicator light		3.4

BRAKE + WHEEL

Unit: mm (in)

ITEM	STANDARD/SPECIFICATION		LIMIT
Front brake lever free travel	30 (1.2)		—
Rear brake pedal free travel	20 – 30 (0.8 – 1.2)		—
Brake drum I.D.	Front	—	120.7 (4.75)
	Rear	—	150.7 (5.93)
Brake lining thickness	—		1.5 (0.06)
Steering angle	Inside	41°	—
	Outside	30°	—
Turning radius	2.4 m (7.9 ft)		—
Toe-in (with 75 kg, 165 lbs)	3 – 11 (0.1 – 0.4)		—
Caster	8°		—
Trail	31 (1.2)		—
Wheel axle runout	Rear	—	8.0 (0.31)
Wheel rim size	Front	8 × 5.5 AT	—
	Rear	8 × 8.0 AT	—
Tire size	Front	AT 20 × 7-8 ☆	—
	Rear	AT 22 × 10-8 ☆	—
Tire tread depth	Front	4.0 (0.16)	—
	Rear	4.0 (0.16)	—

SUSPENSION

ITEM	STANDARD	LIMIT	NOTE
Rear shock absorber spring setting	2nd position	—	
Front wheel travel	80 (3.1)	—	
Rear wheel travel	90 (3.5)	—	
Swingarm pivot shaft runout	—	0.6 (0.02)	

TIRE PRESSURE

COLD INFLATION TIRE PRESSURE	LOAD CAPACITY		
	130 kg (285 lbs)		
	kPa	kgf/cm ²	psi
FRONT	25	0.25	3.6
REAR	20	0.20	2.9

FUEL + OIL

ITEM	SPECIFICATION		NOTE
Fuel type	Use only unleaded gasoline of at least 87 pump octane (R/2 + M/2) or 91 octane or higher rated by the research method. Gasoline containing MTBE (Methyl Tertiary Butyl Ether), less than 10% ethanol, or less than 5% methanol with appropriate cosolvents and corrosion inhibitor is permissible.		
Fuel tank including reserve	8.5 L (2.2/1.9 US/Imp gal)		
reserve	1.1 L (0.3/0.2 US/Imp gal)		
Engine oil type	SAE 10W/40, API, SF or SG		
Engine oil capacity	Change	1 500 ml (1.6/1.3 US/Imp qt)	
	Filter change	1 700 ml (1.8/1.5 US/Imp qt)	
	Overhaul	1 900 ml (2.0/1.8 US/Imp qt)	

**LT-F160
VALVE + GUIDE**

Unit: mm (in)

ITEM	STANDARD		LIMIT
Valve diam.	IN.	28 (1.1)	—
	EX.	25 (1.0)	—
Valve clearance (when cold)	IN.	0.03 – 0.08 (0.001 – 0.003)	—
	EX.	0.05 – 0.10 (0.002 – 0.004)	—
Valve guide to valve stem clearance	IN.	0.010 – 0.037 (0.0004 – 0.0015)	—
	EX.	0.030 – 0.057 (0.0012 – 0.0022)	—
Valve stem deflection	IN. & EX.	—	0.35 (0.014)
Valve guide I.D.	IN. & EX.	5.500 – 5.512 (0.2165 – 0.2170)	—
Valve stem O.D.	IN.	5.475 – 5.490 (0.2155 – 0.2161)	—
	EX.	5.455 – 5.470 (0.2148 – 0.2153)	—
Valve stem runout	IN. & EX.	—	0.05 (0.002)
Valve head thickness	IN. & EX.	—	0.5 (0.02)
Valve stem end length	IN. & EX.	—	2.5 (0.10)
Valve seat width	IN. & EX.	0.9 – 1.1 (0.035 – 0.043)	—
Valve head radial runout	IN. & EX.	—	0.03 (0.001)
Valve spring free length (IN. & EX.)	—		39.5 (1.56)
Valve spring tension (IN. & EX.)	18.4 – 21.6 kg (40.6 – 47.6 lbs) at length 36.8 mm (1.45 in)		—

CAMSHAFT + CYLINDER HEAD

Unit: mm (in)

ITEM	STANDARD		LIMIT
Cam height	IN.	33.490 – 33.530 (1.3185 – 1.3201)	33.190 (1.3067)
	EX.	33.353 – 33.393 (1.3131 – 1.3147)	33.060 (1.3016)
Camshaft journal oil clearance	IN. & EX.	0.032 – 0.066 (0.0013 – 0.0026)	0.150 (0.0059)
Camshaft journal holder I.D.	IN. & EX.	22.012 – 22.025 (0.8666 – 0.8671)	—
Camshaft journal O.D.	IN. & EX.	21.959 – 21.980 (0.8645 – 0.8654)	—
Camshaft runout	IN. & EX	—	0.10 (0.004)
Rocker arm I.D.	IN. & EX	12.000 – 12.018 (0.4724 – 0.4731)	—
Rocker arm shaft O.D.	IN. & EX	11.977 – 11.995 (0.4715 – 0.4722)	—
Cylinder head distortion	—		0.05 (0.002)
Cylinder head cover distortion	—		0.05 (0.002)

CYLINDER + PISTON + PISTON RING

Unit: mm (in)

ITEM	STANDARD		LIMIT
Compression pressure	1 000 – 1 400 kPa (10 – 14 kgf/cm ² , 142 – 199 psi)		800 kPa (8 kgf/cm ² , 114 psi)
Piston to cylinder clearance	0.030 – 0.040 (0.0012 – 0.0016)		0.120 (0.0047)
Cylinder bore	58.000-58.015 (2.2835 – 2.2841)		58.100 (2.2874)
Piston diam.	57.965 – 57.980 (2.2821 – 2.2827) Measure at 20 mm (0.8 in) from the skirt end.		57.880 (2.2787)
Cylinder distortion	—		0.05 (0.002)
Piston ring free end gap	1st	R	Approx. 5.8 (0.23)
	2nd	R	Approx. 7.4 (0.29)
Piston ring end gap	1st & 2nd		0.010 – 0.025 (0.004 – 0.010)
Piston ring to groove clearance	1st		—
	2nd		—
Piston ring groove width	1st & 2nd		1.21 – 1.23 (0.0476 – 0.0484)
	Oil		2.51 – 2.53 (0.0988 – 0.0996)

ITEM	STANDARD		LIMIT
Piston ring thickness	1st & 2nd	1.17 – 1.19 (0.046 – 0.047)	—
Piston pin bore		14.002 – 14.008 (0.5513 – 0.5515)	14.030 (0.5524)
Piston pin O.D.		13.996 – 14.000 (0.5510 – 0.5512)	13.980 (0.5504)

CONROD + CRANKSHAFT

Unit: mm (in)

ITEM	STANDARD		LIMIT
Conrod small end I.D.		14.004 – 14.012 (0.5513 – 0.5517)	14.040 (0.5528)
Conrod deflection		—	3.0 (0.12)
Conrod big end side clearance		0.10 – 0.45 (0.0039 – 0.0177)	1.00 (0.039)
Conrod big end width		15.95 – 16.00 (0.628 – 0.630)	—
Crank web to web width		53.0 ± 0.1 (2.087 ± 0.004)	—
Crankshaft runout		—	0.05 (0.002)

OIL PUMP

ITEM	STANDARD	LIMIT
Oil pressure (at 60°C, 140°F)	Above 30 kPa (0.30 kgf/cm ² , 4.3 psi) Below 70 kPa (0.70 kgf/cm ² , 10.0 psi) at 3 000 r/min.	—

CLUTCH

Unit: mm (in)

ITEM	STANDARD	LIMIT
Clutch release screw	0 – 1/8 turn back	—
Drive plate thickness	2.7 – 2.9 (0.106 – 0.114)	2.4 (0.094)
Drive plate claw width	11.8 – 12.0 (0.46 – 0.47)	11.0 (0.43)
Driven plate distortion	—	0.10 (0.004)
Clutch spring free length	—	27.6 (1.09)
Clutch shoe	—	No groove at any parts
Clutch engagement	2 200 ± 200 r/min.	—
Clutch lock-up	3 500 ± 250 r/min.	—

DRIVE TRAIN

Unit: mm (in) Except ratio

ITEM		STANDARD		LIMIT
Primary reduction ratio		3.736 (71/19)		—
Final reduction ratio	P-51	*4.090 (45/11)		—
	The others	3.545 (39/11)		—
Gear ratios	Low	3.166 (38/12)		—
	2nd	2.142 (30/14)		—
	3rd	1.588 (27/17)		—
	4th	1.200 (24/20)		—
	Top	0.950 (19/20)		—
	Reverse	2.833 (29/12 × 34/29)		—
Shift fork to groove clearance		0.10 – 0.30 (0.004 – 0.012)		0.50 (0.020)
Shift fork groove width	No.1, No.2 & No.3	4.50 – 4.60 (0.177 – 0.181)		—
	Reverse	4.00 – 4.10 (0.157 – 0.161)		—
Shift fork thickness	No.1, No.2 & No.3	4.30 – 4.40 (0.169 – 0.173)		—
	Reverse	3.80 – 3.90 (0.150 – 0.154)		—
Drive chain	Type	TAKASAGO: RK520SM		—
	Links	P-51	*88	—
		The others	84	
20-pitch length	—		319.4 (12.57)	
Drive chain slack		20 – 30 (0.8 – 1.2)		—
Gearshift lever height		10 (0.4)		—

CARBRETOR

ITEM	SPECIFICATION	
	P-24, 28	P-51
Carburetor type	MIKUNI VM20SS	←
Bore size	20 mm	←
I.D. No.	02C02	02C2
Idle r/min.	1 500 ± 100 r/min.	←
Float height	25.8 ± 1.0 mm (1.02 ± 0.04 in)	←
Main jet (M.J.)	#87.5	←
Jet needle (J.N.)	5FU96-3rd	←
Needle jet (N.J.)	O-1	←
Pilot jet (P.J.)	#22.5	←
Starter jet (G.S.)	#22.5	←
Pilot screw (P.S.)	1 5/8 turns back	←
Throttle cable play	3 – 5 mm (0.12 – 0.20 in)	←
Starter cable play	0.5 – 1.0 mm (0.02 – 0.04 in)	←

ELECTRICAL

Unit: mm (in)

ITEM		SPECIFICATION		NOTE
Spark plug		Type	NGK: DPR7EA-9 ND: X22EPR-U9	
		Gap	0.8 – 0.9 (0.031 – 0.035)	
Spark performance		Over 8 (0.3) at 1 atm.		
Ignition coil resistance		Primary	0.1 – 1.0 Ω	Terminal – Ground
		Secondary	10 – 25 kΩ	Plug cap – Ground
Magneto coil resistance		Pulser	380 – 600 Ω	BI – G
		Charging	0.5 – 1.2 Ω	Y – Y
Generator no-load voltage		More than 55 V (AC) at 5 000 r/min.		
Generator Max. output		Approx. 150 W at 5 000 r/min.		
Regulated voltage		13.5 – 15.5 V at 5 000 r/min.		
Starter relay resistance		3 – 7 Ω		
Battery	Type designation	YB9A-A		
	Capacity	12 V 32.4 kC (9 Ah)/10 HR		
	Standard electrolyte S.G.	1.28 at 20°C (68°F)		
Fuse size		15 A		

WATTAGE

Unit: W

ITEM		SPECIFICATION
Headlight	HI	45
	LO	45
Brake light/Taillight		*21/5
Reverse indicator light		3.4
Neutral indicator light		3.4

BRAKE + WHEEL

Unit: mm (in)

ITEM	STANDARD/SPECIFICATION		LIMIT
Front brake lever free travel	30 (1.2)		—
Rear brake pedal free travel	20 – 30 (0.8 – 1.2)		—
Brake drum I.D.	Front	—	120.7 (4.75)
	Rear	—	150.7 (5.93)
Brake lining thickness	—		1.5 (0.06)
Steering angle	Inside	41°	—
	Outside	30°	—
Turning radius	2.4 m (7.9 ft)		—
Toe-in (with 75 kg, 165 lbs)	3 – 11 (0.1 – 0.4)		—
Caster	8°		—
Trail	31 (1.2)		—
Wheel axle runout	Rear	—	8.0 (0.31)
Wheel rim size	Front	8 × 5.5 AT	—
	Rear	8 × 8.0 AT	—
Tire size	Front	AT 20 × 7-8 ☆	—
	Rear	AT 22 × 10-8 ☆	—
Tire tread depth	Front	4.0 (0.16)	—
	Rear	4.0 (0.16)	—

SUSPENSION

ITEM	STANDARD	LIMIT	NOTE
Rear shock absorber spring setting	2nd position	—	
Front wheel travel	80 (3.1)	—	
Rear wheel travel	90 (3.5)	—	
Swingarm pivot shaft runout	—	0.6 (0.02)	

TIRE PRESSURE

COLD INFLATION TIRE PRESSURE	LOAD CAPACITY		
	130 kg (285 lbs)		
	kPa	kgf/cm ²	psi
FRONT	25	0.25	3.6
REAR	20	0.20	2.9

FUEL + OIL

ITEM	SPECIFICATION		NOTE
Fuel type	Use only unleaded gasoline of at least 87 pump octane (R/2 + M/2) or 91 octane or higher rated by the research method. Gasoline containing MTBE (Methyl Tertiary Butyl Ether), less than 10% ethanol, or less than 5% methanol with appropriate cosolvents and corrosion inhibitor is permissible.		P-28
	Gasoline used should be graded 91 octane or higher. An unleaded gasoline is recommended.		P-24, 51
Fuel tank including reserve	8.5 L (2.2/1.9 US/Imp gal)		
reserve	1.1 L (0.3/0.2 US/Imp gal)		
Engine oil type	SAE 10W/40, API, SF or SG		
Engine oil capacity	Change	1 500 ml (1.6/1.3 US/Imp qt)	
	Filter change	1 700 ml (1.8/1.5 US/Imp qt)	
	Overhaul	1 900 ml (2.0/1.8 US/Imp qt)	

WIRING DIAGRAM

LT160 AND LT-F160

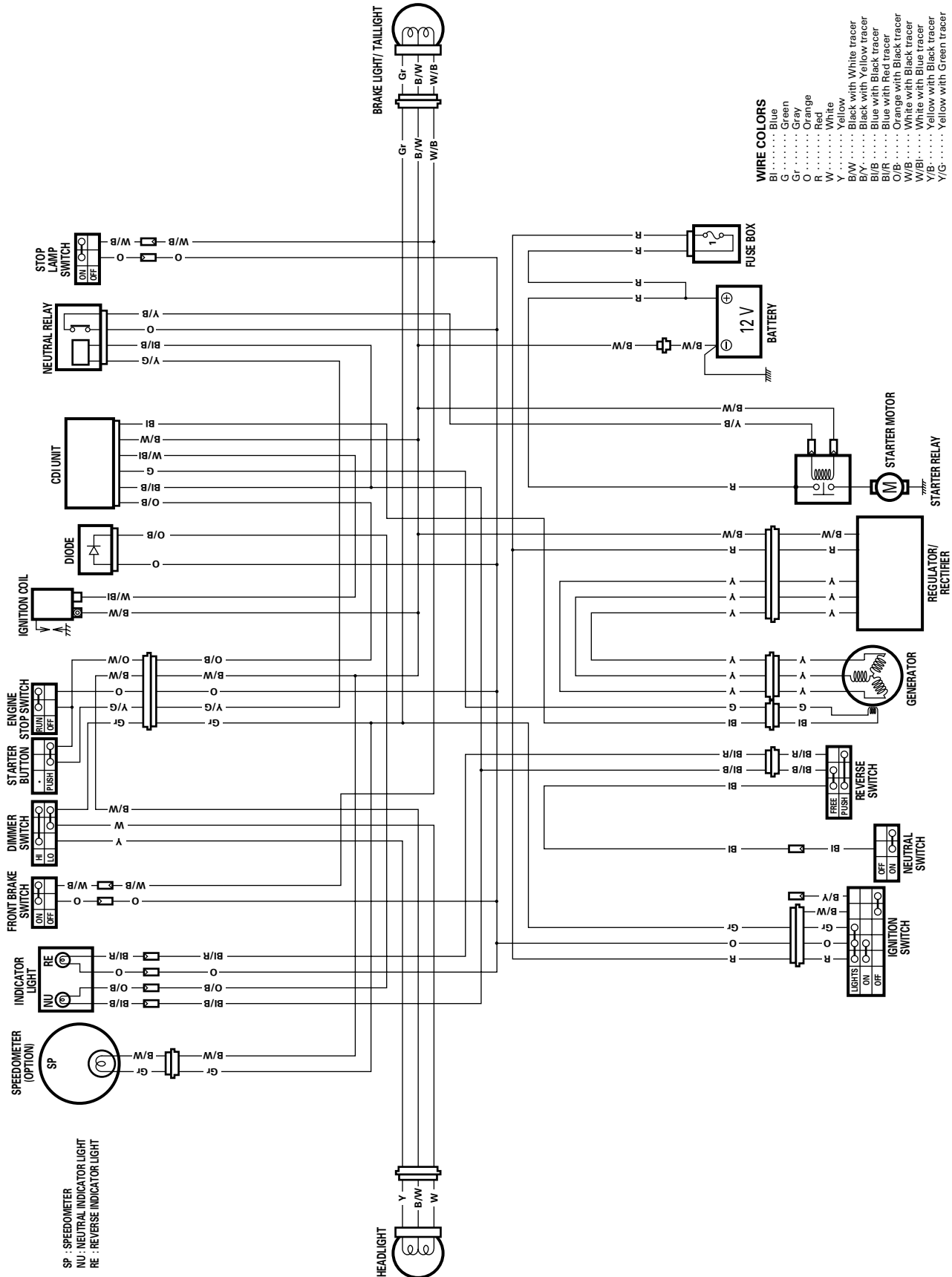

Prepared by

SUZUKI MOTOR CORPORATION

15th Ed. August, 2004

1st Ed. November, 1988

Part No. 99500-41114-01E

Printed in Japan

SUZUKI MOTOR CORPORATION

Printed in Japan (TK)

K L M N P R S T V W X Y K1 K2 K3 K4 K5