

Honda Civic 1996-2000

Engine Mechanical

Engine

Engine Removal/Installation	5-1
Cylinder Head/Valve Train	6-1
Engine Block	7-1
Engine Lubrication	8-1
Intake Manifold/Exhaust System	9-1
Cooling	10-1



Engine Removal/Installation

Removal	5-2
Installation	5-12



Engine Removal/Installation

Removal

⚠ WARNING

- Make sure jacks and safety stands are placed properly and hoist brackets are attached to the correct positions on the engine.
- Make sure the vehicle will not roll off stands and fall while you are working under it.

CAUTION:

- Use fender covers to avoid damaging painted surface.
- Unplug the wiring connectors carefully while holding the connector portion to avoid damage.
- Mark all wiring and hoses to avoid misconnection. Also, be sure that they do not contact other wiring or hoses or interfere with other parts.

1. Secure the hood as open as possible.
2. Disconnect the battery negative terminal first, then the positive terminal. Remove the battery.
3. Remove the strut brace (B16A2 engine).

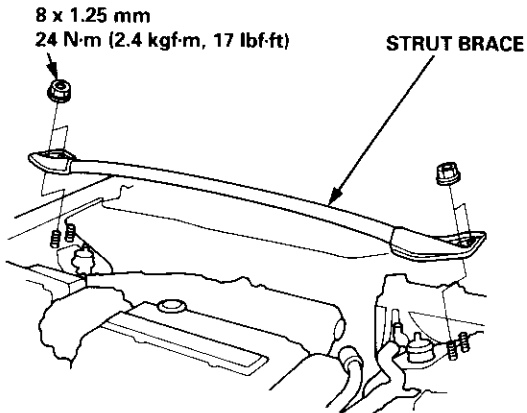

4. Disconnect the battery cables from the under-hood fuse/relay box and battery positive terminal.

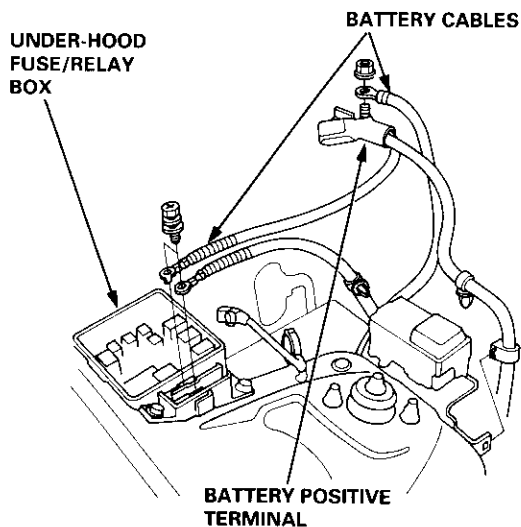

5. Remove the battery and battery base.

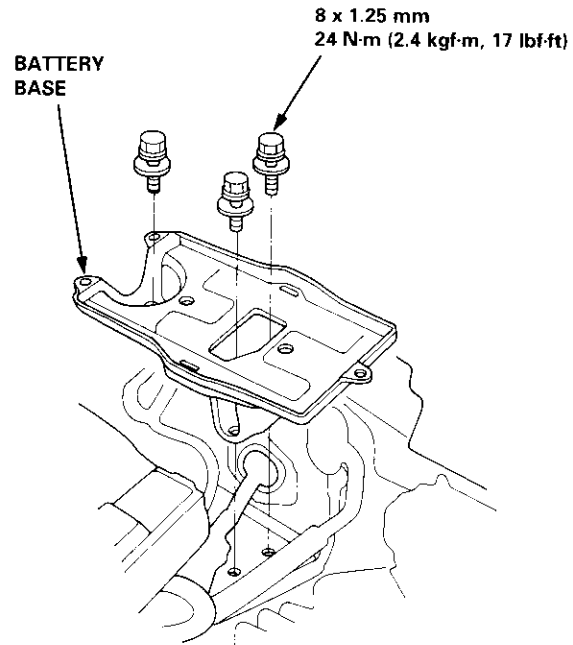

6. Disconnect the connectors from the ECM/PCM.
7. Disconnect the main wire harness connector.

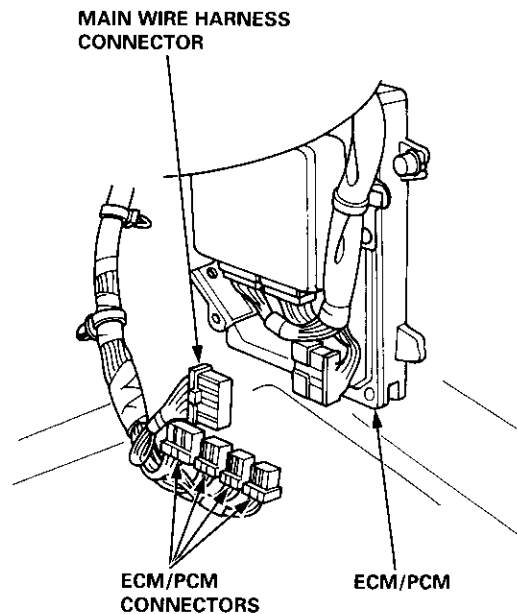



8. Remove the intake air duct and air cleaner housing.

D16Y7 engine:

- a. Remove the resonator and intake air duct.

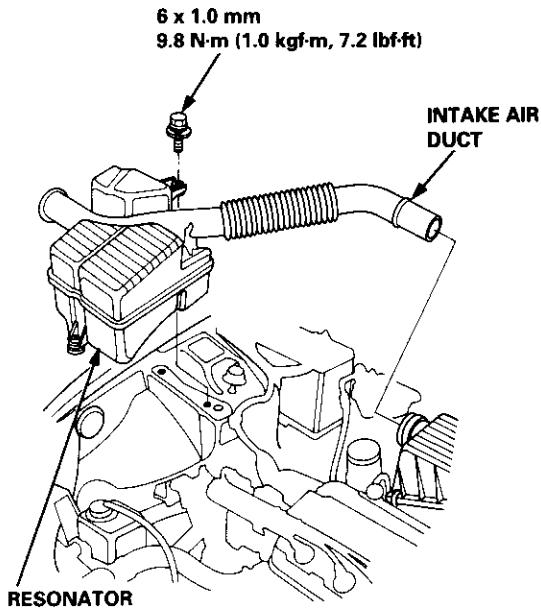

- b. Disconnect the intake air temperature (IAT) sensor connector, then remove the air cleaner housing.

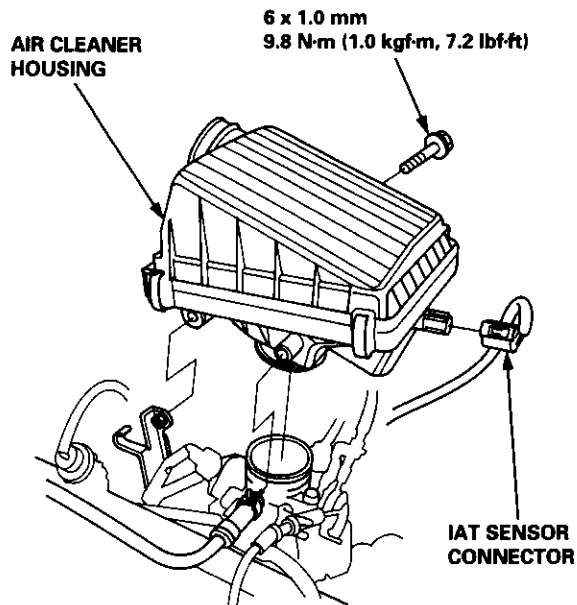

D16Y5, D16Y8, B16A2 engines:

- a. Disconnect the IAT sensor connector, then remove the intake air duct and air cleaner housing.

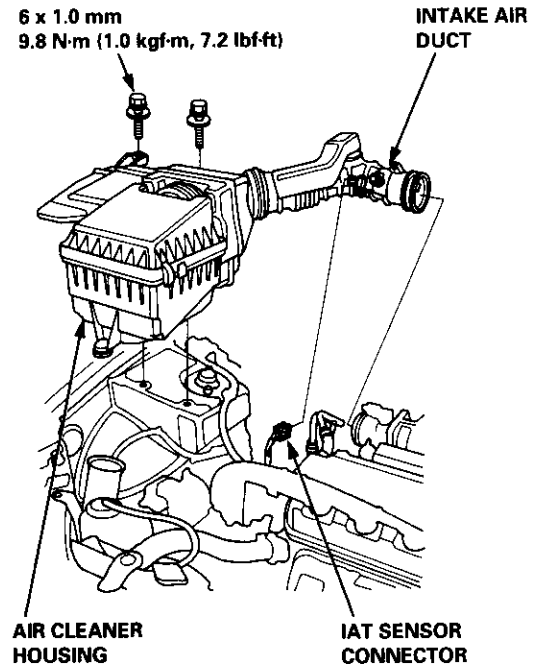

9. Disconnect the engine wire harness connector on the left side of the engine compartment.

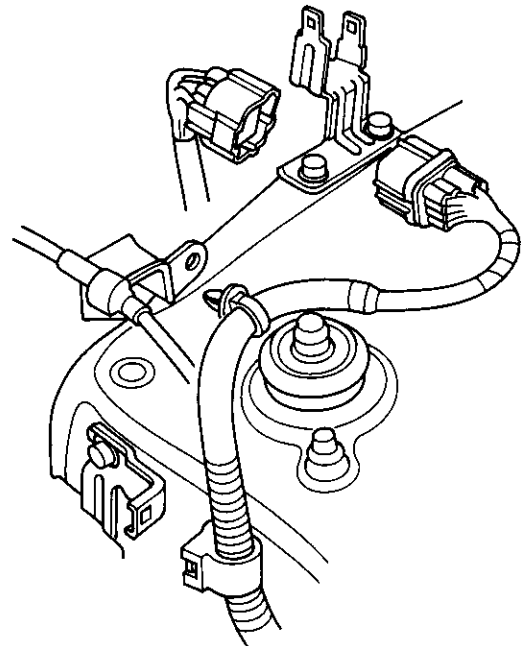

(cont'd)

Engine Removal/Installation

Removal (cont'd)

10. Relieve fuel pressure (see section 11).

⚠ WARNING Do not smoke while working on the fuel system. Keep open flame or spark away from the work area. Drain fuel only into an approved container.

11. Remove the evaporative emission (EVAP) control canister hose and fuel feed hose.

D16Y7 engine:

BANJO BOLT
33 N·m (3.4 kgf·m, 25 lbf·ft)

WASHERS
Replace.

EVAP CONTROL CANISTER HOSE

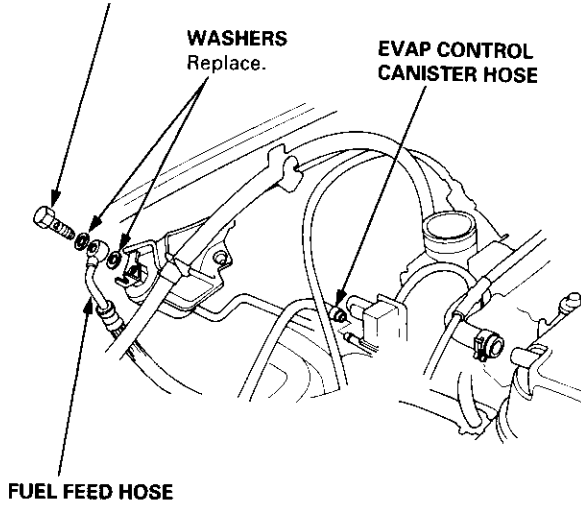

FUEL FEED HOSE

D16Y5, D16Y8, B16A2 engines:

BANJO BOLT
33 N·m (3.4 kgf·m,
25 lbf·ft)

WASHERS
Replace.

EVAP CONTROL CANISTER HOSE

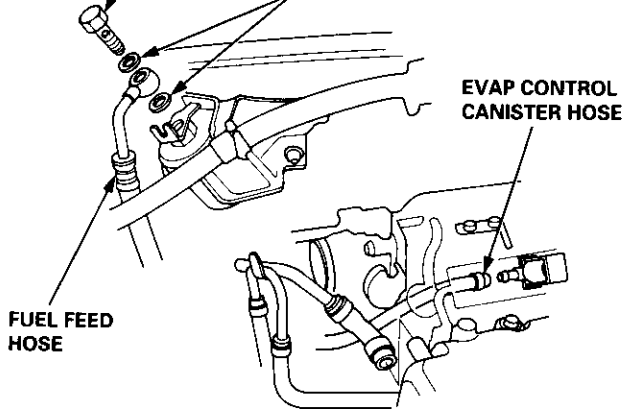

FUEL FEED HOSE

12. Remove the brake booster vacuum hose, fuel return hose and vacuum hose.

D16Y7 engine:

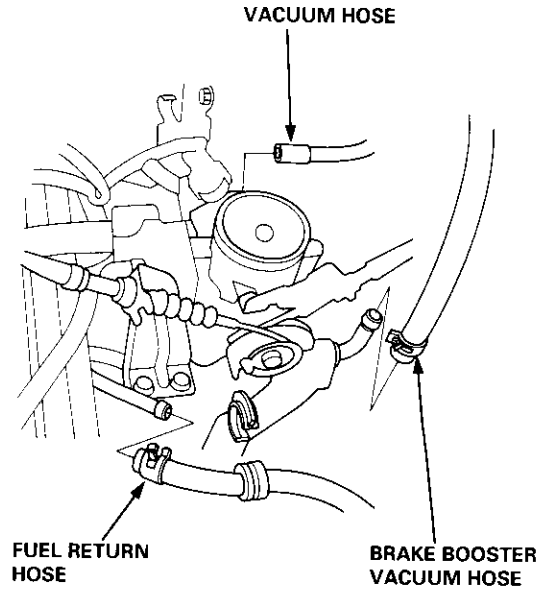

FUEL RETURN HOSE

BRAKE BOOSTER VACUUM HOSE

D16Y5, D16Y8, B16A2 engines:

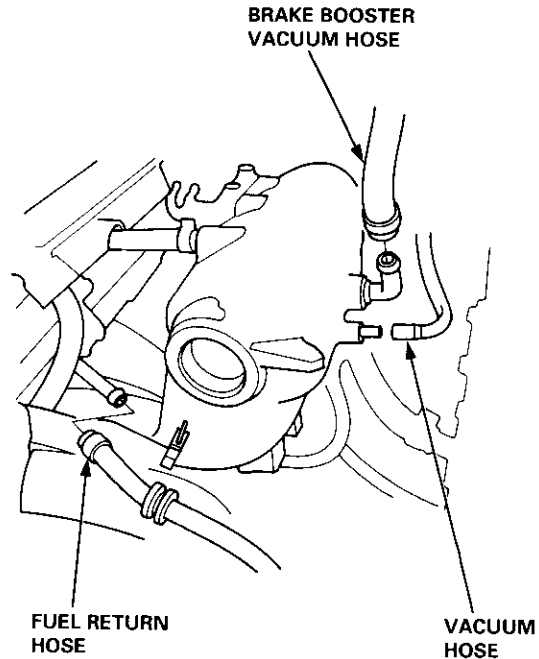

FUEL RETURN HOSE

VACUUM HOSE



13. Remove the throttle cable by loosening the locknut, then slip the cable end out of the accelerator linkage.

NOTE:

- Take care not to bend the cable when removing it. Always replace any kinked cable with a new one.
- Adjust the throttle cable when installing (see section 11).

D16Y7 engine:

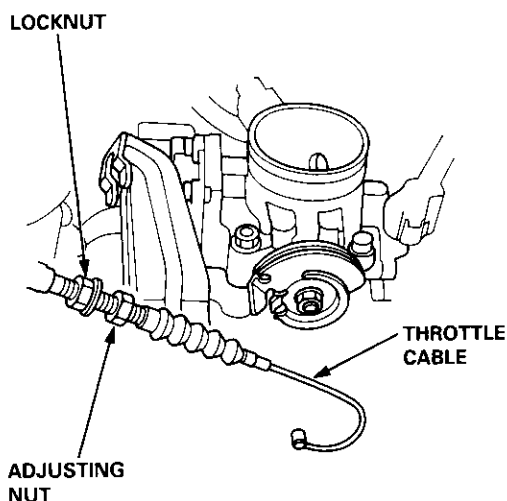

D16Y5, D16Y8, B16A2 engines:

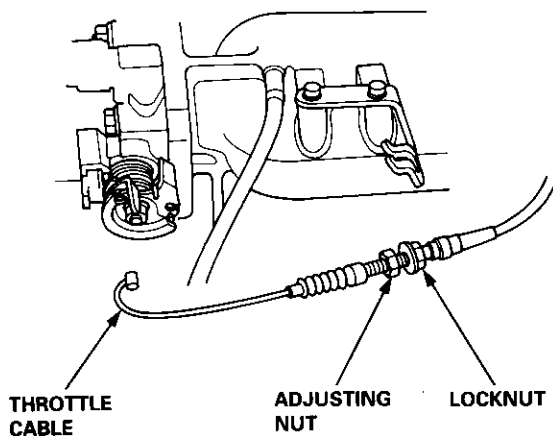

14. Disconnect the connectors from the PCM.

15. Remove the grommet and wire harness clamps, then pull out the ECM/PCM connectors.

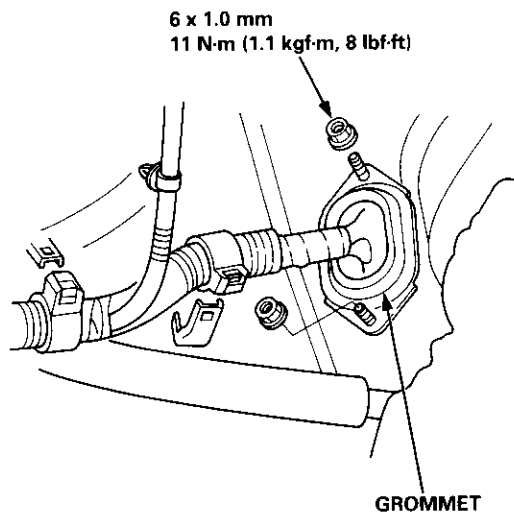

16. Remove the mounting bolt and lock bolt, then remove the power steering (P/S) pump belt and pump.

NOTE: Do not disconnect the P/S hoses.

B16A2 engine:

- 1. Remove the adjusting bolt and mounting bolts, then remove the P/S pump belt and pump.

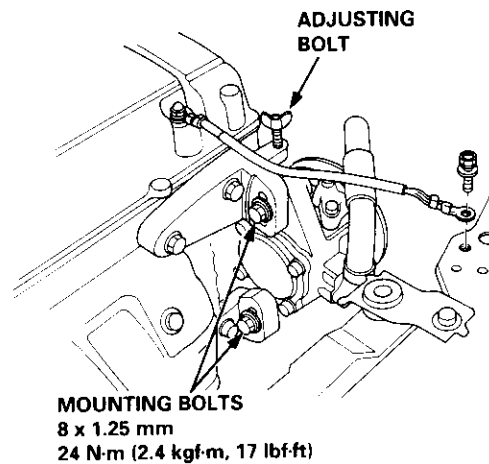

(cont'd)

Engine Removal/Installation

Removal (cont'd)

D16Y5, D16Y7, D16Y8 engines:

- 1. Remove the mounting bolt and lock bolt, then remove the P/S pump belt and pump.

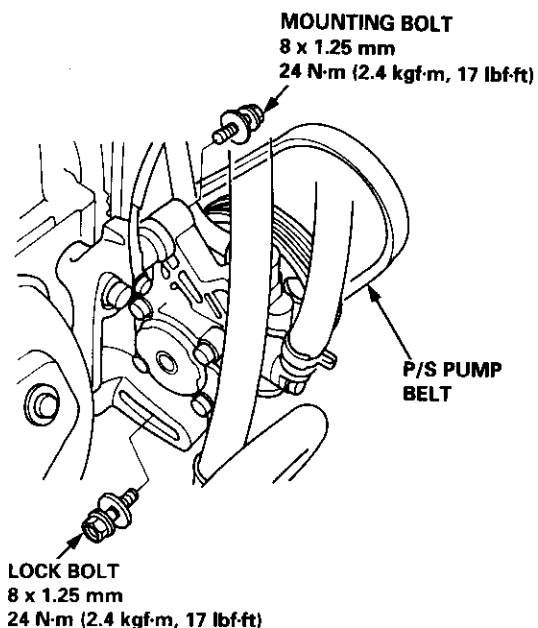

17. Loosen the idler pulley center nut and adjusting bolt, then remove the air conditioning (A/C) compressor belt.

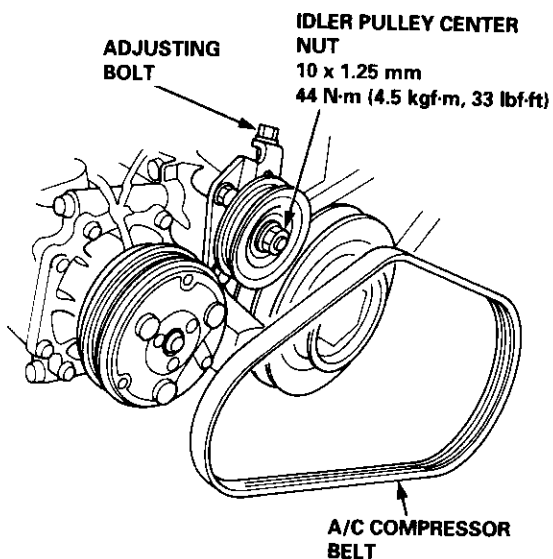

18. Remove the transmission ground cable and hose clamp.

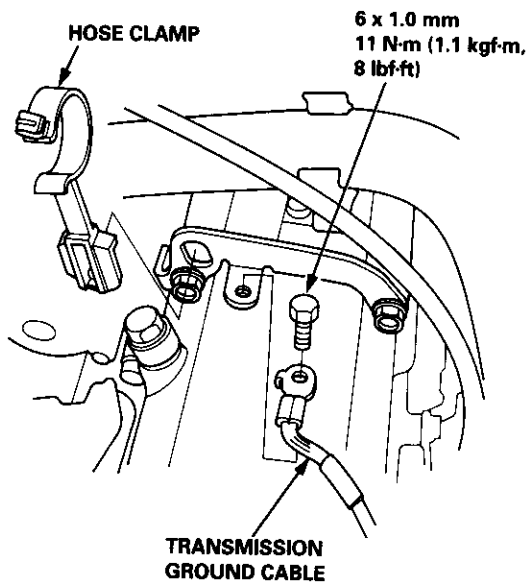

19. Remove the clutch slave cylinder and line/hose assembly (M/T).

NOTE:

- Do not disconnect the pipe/hose assembly.
- Do not operate the clutch pedal once the slave cylinder has been removed.
- Take care not to bend the line.

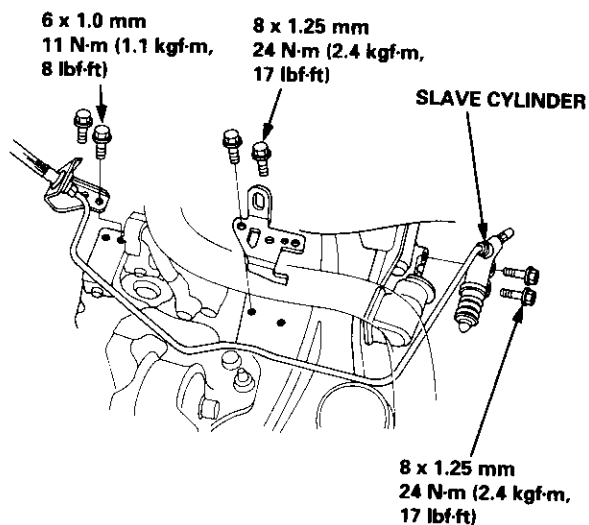



20. Remove the shift cable (CVT).

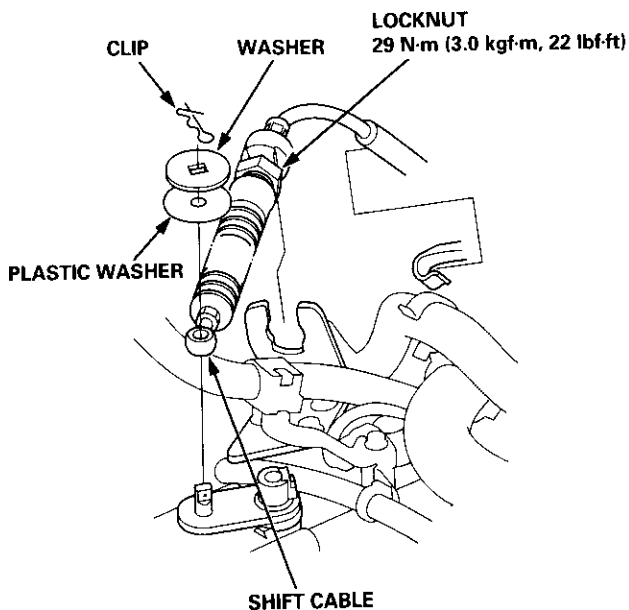

21. Disconnect the power steering pressure (PSP) switch connector, and remove the wire harness clamp.



22. Remove the radiator cap.

▲ WARNING Use care when removing the radiator cap to avoid scalding by hot coolant or steam.

23. Raise the hoist to full height.

24. Remove the front tires/wheels and splash shield.

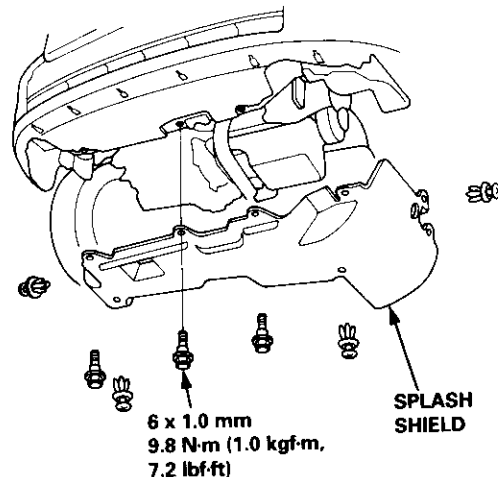

25. Drain the engine coolant (see page 10-7). Loosen the drain plug in the radiator.

26. Drain the transmission fluid. Reinstall the drain plug using a new washer (see section 13, 14).

27. Drain the engine oil. Reinstall the drain bolt using a new washer (see page 8-6).

28. Remove the shift rod and extension rod (M/T).

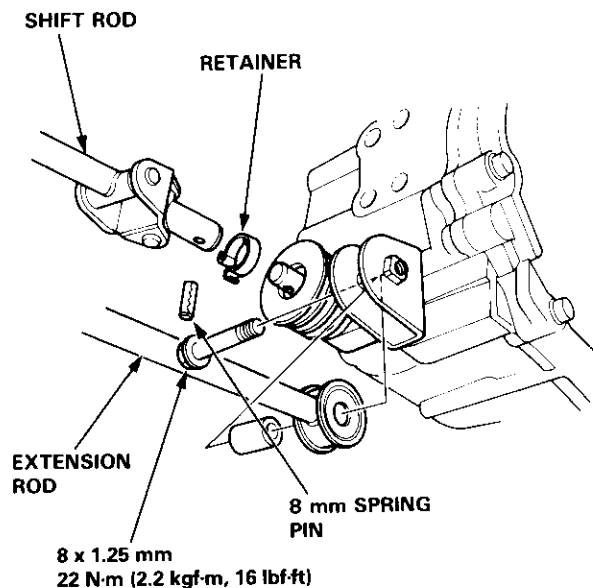

(cont'd)

Engine Removal/Installation

Removal (cont'd)

29. Remove the A/C compressor.

NOTE: Do not disconnect the A/C hoses.

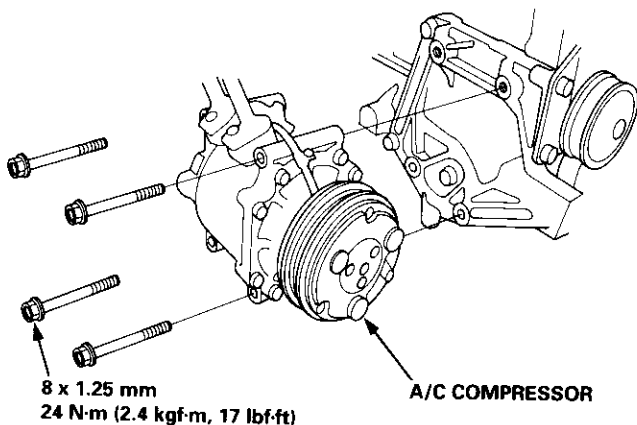

30. Remove the shift cable (A/T).

NOTE:

- Take care not to bend the cable when removing it. Always replace any kinked cable with a new one.
- Adjust the shift cable when installing (see section 14).

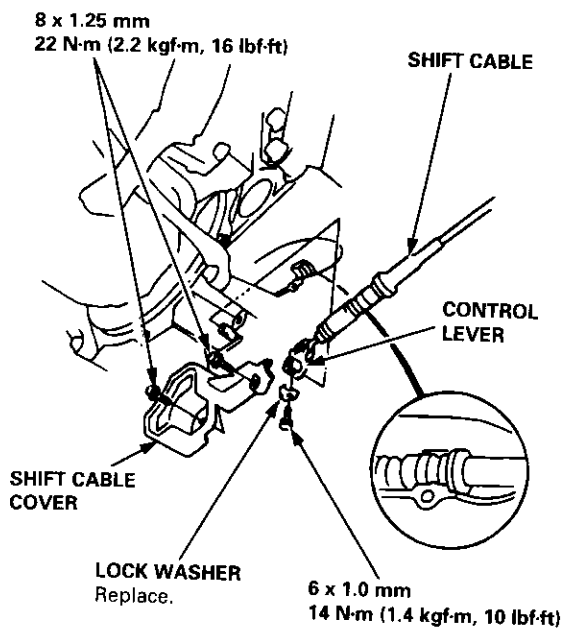

31. Remove exhaust pipe A.

D16Y5, D16Y7 engines:

8 x 1.25 mm
22 N·m (2.2 kgf-m, 16 lbf-ft)
Replace.

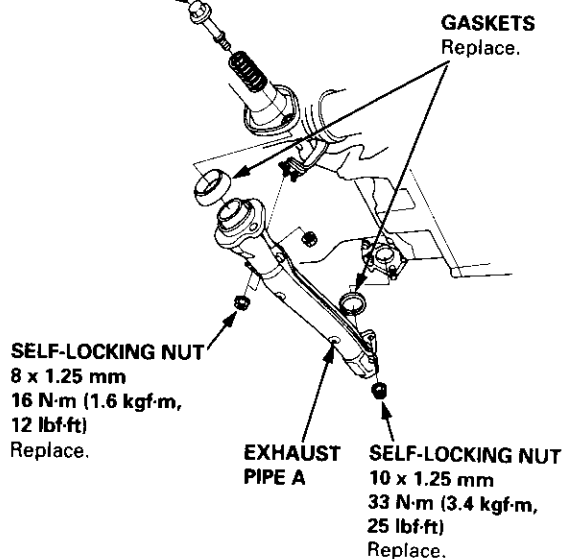

D16Y8 engine:

8 x 1.25 mm
22 N·m (2.2 kgf-m, 16 lbf-ft)
Replace.

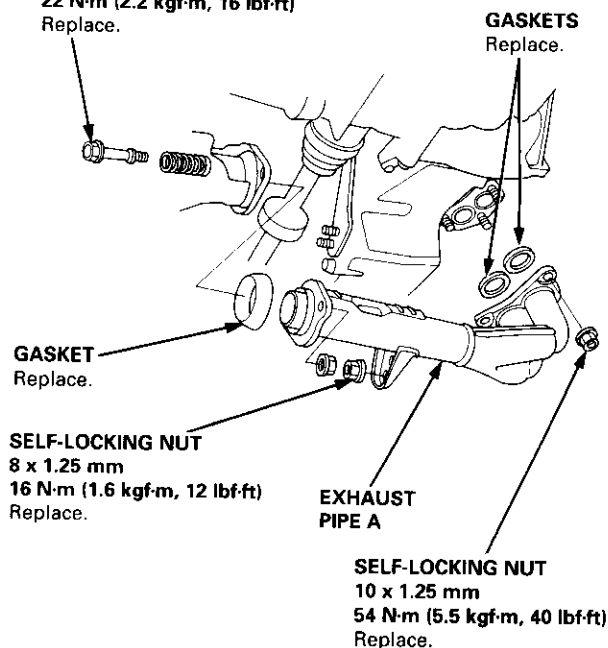



B16A2 engine:

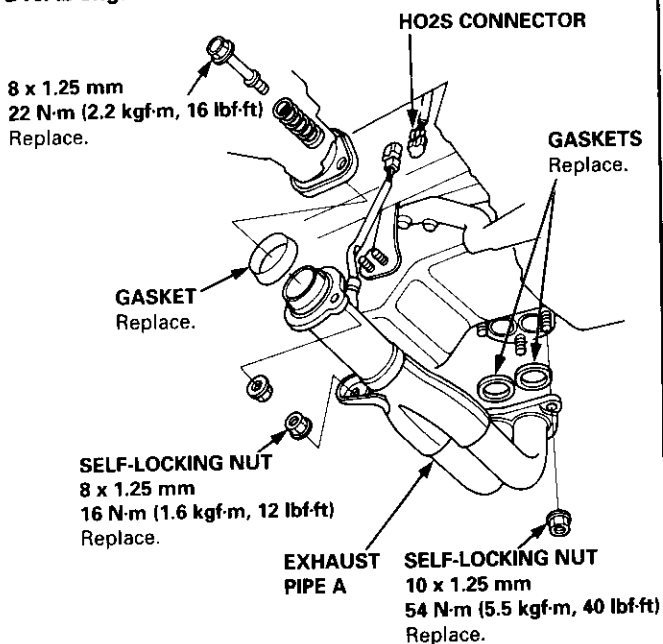

32. Remove the damper forks (see section 18).
33. Disconnect the suspension lower arm ball joints (see section 18).
34. Remove the driveshafts.

CAUTION:

- Do not pull on the driveshaft, the CV joint may come apart.
- Use care when prying out the assembly. Pull it straight to avoid damaging the differential oil seal or intermediate shaft dust seal.

NOTE: Coat all precision-finished surfaces with clean engine oil. Tie plastic bags over the driveshaft ends.

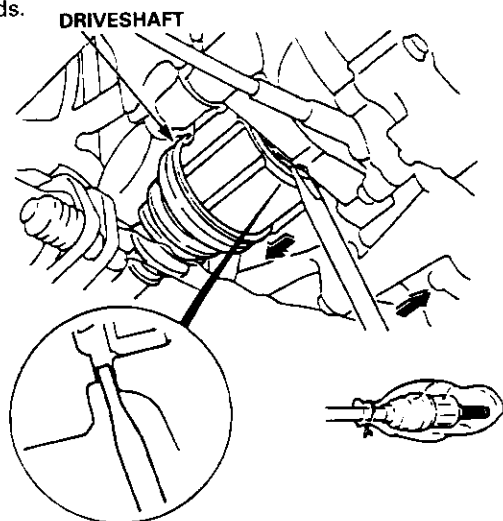

35. Lower the hoist.

36. Remove the upper and lower radiator hoses and heater hoses.

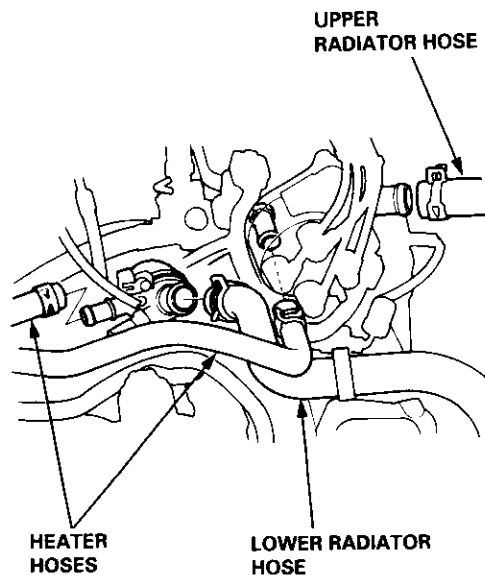

37. Remove the ATF cooler hoses, then plug the ATF cooler hoses and pipes (A/T).

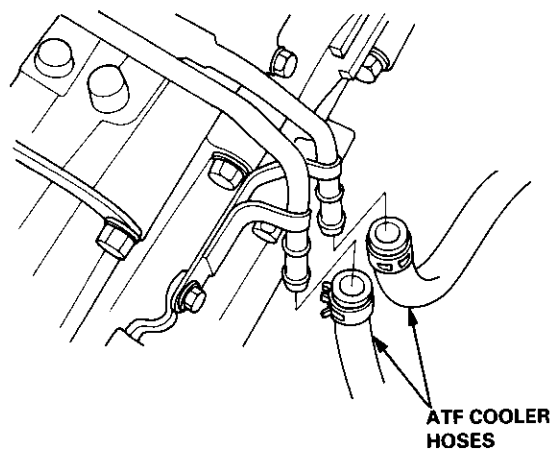

(cont'd)

Engine Removal/Installation

Removal (cont'd)

38. Attach the chain hoist to the engine.

HOISTING BRACKET
Install on the cylinder head
with a 8 x 1.25 mm bolt.

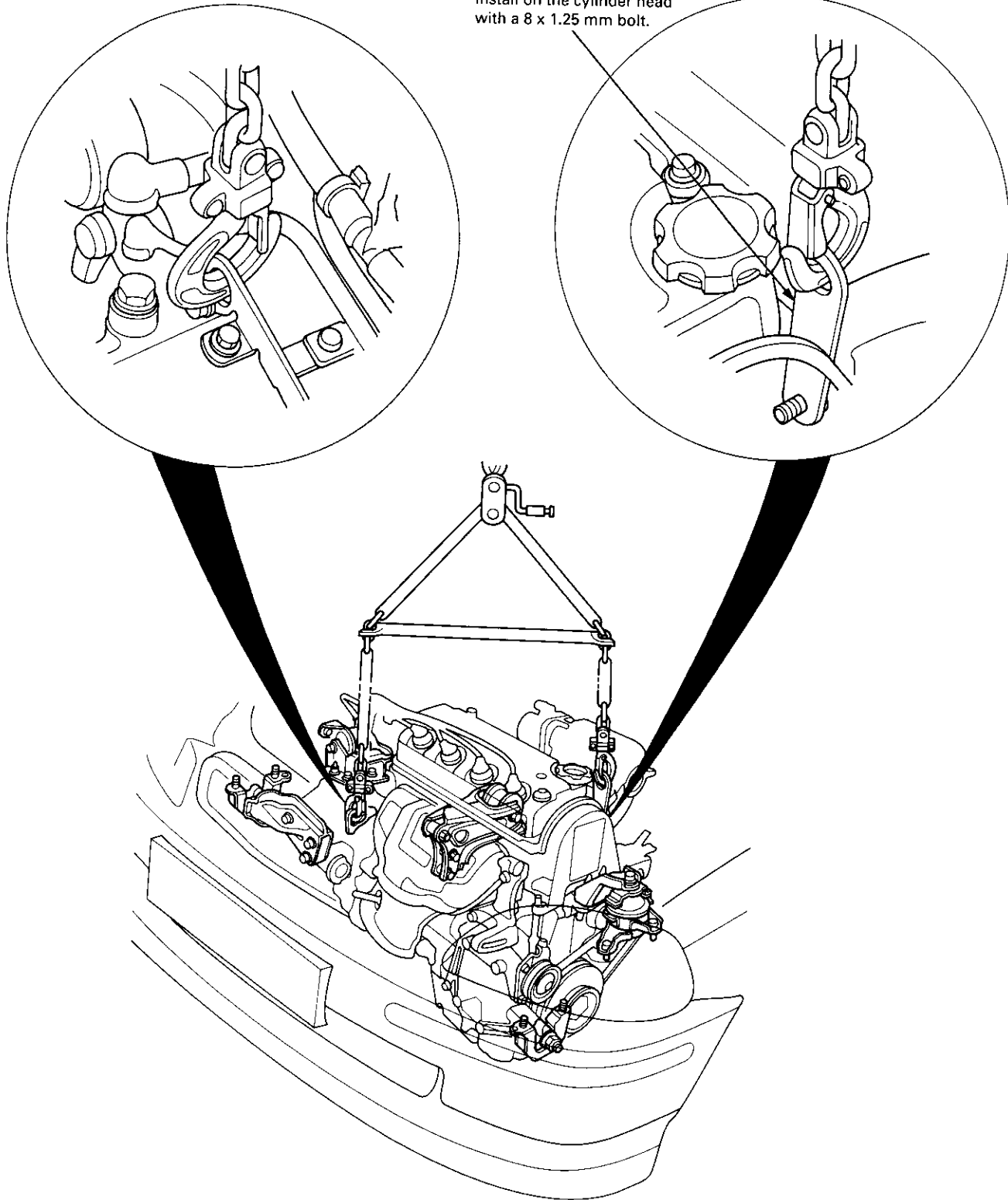



39. Remove the left and right front mount and bracket.

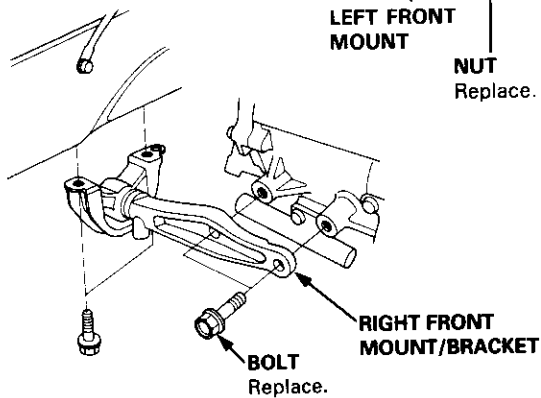
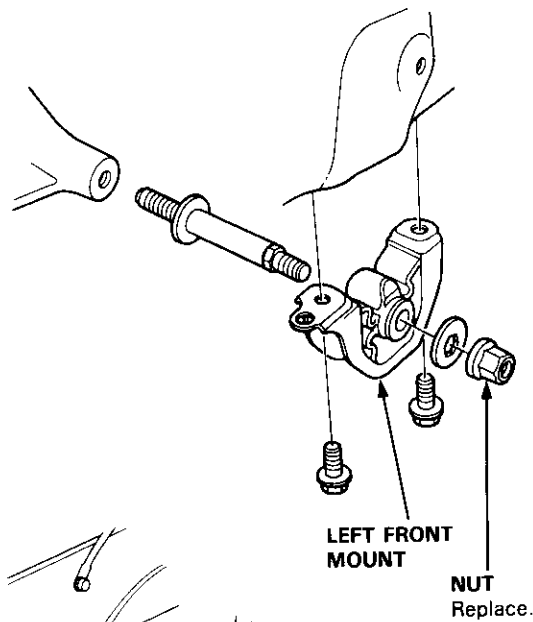

40. Remove the rear mount bracket.

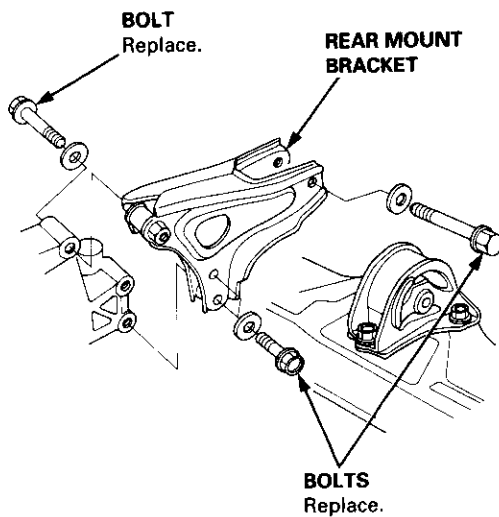

41. Remove the upper bracket.

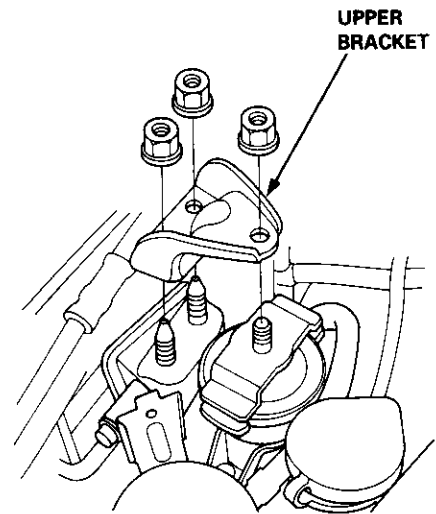

42. Remove the transmission mount bracket, then remove the transmission mount.

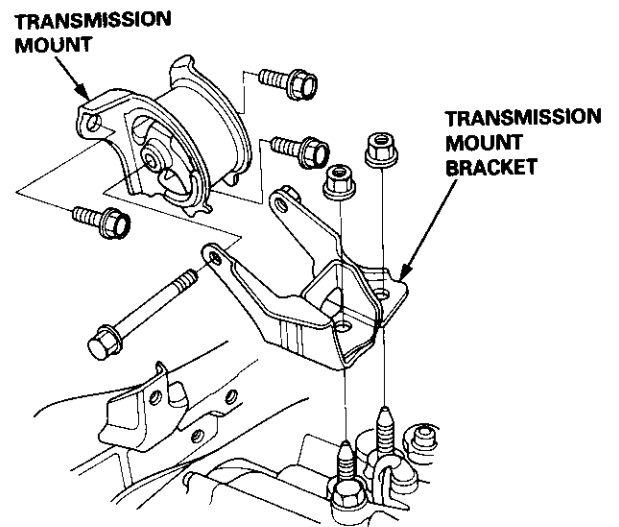

43. Check that the engine/transmission is completely free of vacuum hoses, fuel and coolant hoses and electrical wiring.

44. Slowly raise the engine approximately 150 mm (6 in). Check once again that all hoses and wires are disconnected from the engine/transmission.

45. Raise the engine all the way, and remove it from the car.

Engine Removal/Installation

Installation

Bracket Bolts Torque Specifications:

D16Y5, D16Y7, D16Y8 engines

D16Y5, D16Y8 engines (M/T):

REAR STIFFENER

10 x 1.25 mm
44 N-m (4.5 kgf-m,
33 lbf-ft)

8 x 1.25 mm
24 N-m (2.4 kgf-m, 17 lbf-ft)

10 x 1.25 mm
44 N-m (4.5 kgf-m,
33 lbf-ft)

P/S PUMP
BRACKET

10 x 1.25 mm
54 N-m (5.5 kgf-m,
40 lbf-ft)

ENGINE SIDE
MOUNT BRACKET

EXCEPT D16Y5, D16Y8 engines (M/T):

STIFFENER

Tighten the bolts on the stiffener
in the numbered sequence as shown
(1 - 4).

② 8 x 1.25 mm
24 N-m (2.4 kgf-m,
17 lbf-ft)

④ 10 x 1.25 mm
44 N-m (4.5 kgf-m,
33 lbf-ft)

③ 10 x 1.25 mm
44 N-m (4.5 kgf-m,
33 lbf-ft)

① 8 x 1.25 mm
24 N-m (2.4 kgf-m,
17 lbf-ft)

ALTERNATOR
BRACKET

10 x 1.25 mm
44 N-m (4.5 kgf-m,
33 lbf-ft)

A/C COMPRESSOR
BRACKET

D16Y5, D16Y8
engines (M/T):
FRONT
STIFFENER

8 x 1.25 mm
24 N-m (2.4 kgf-m,
17 lbf-ft)

10 x 1.25 mm
44 N-m (4.5 kgf-m,
33 lbf-ft)

10 x 1.25 mm
44 N-m (4.5 kgf-m,
33 lbf-ft)



B16A2 engine

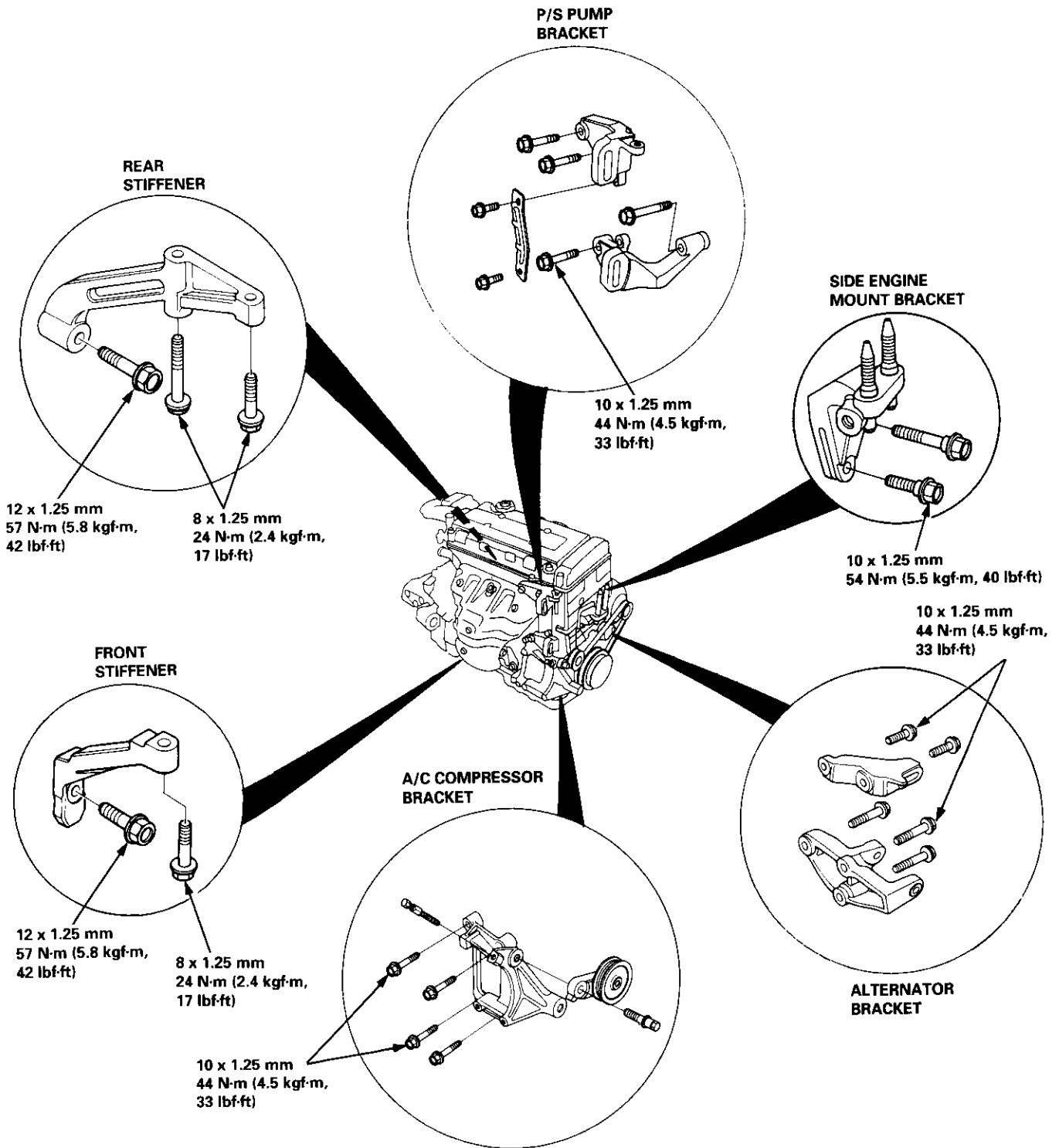

(cont'd)

Engine Removal/Installation

Installation (cont'd)

Engine Installation:

Install the engine in the reverse order of removal. Reinstall the mount bolts/nuts in the following sequence. Failure to follow these procedures may cause excessive noise and vibration, and reduce bushing life.

1. Install the transmission mount and bracket, then tighten the bolts on the frame side.

NOTE: Do not tighten the bolts/nuts on the transmission side.

CVT:

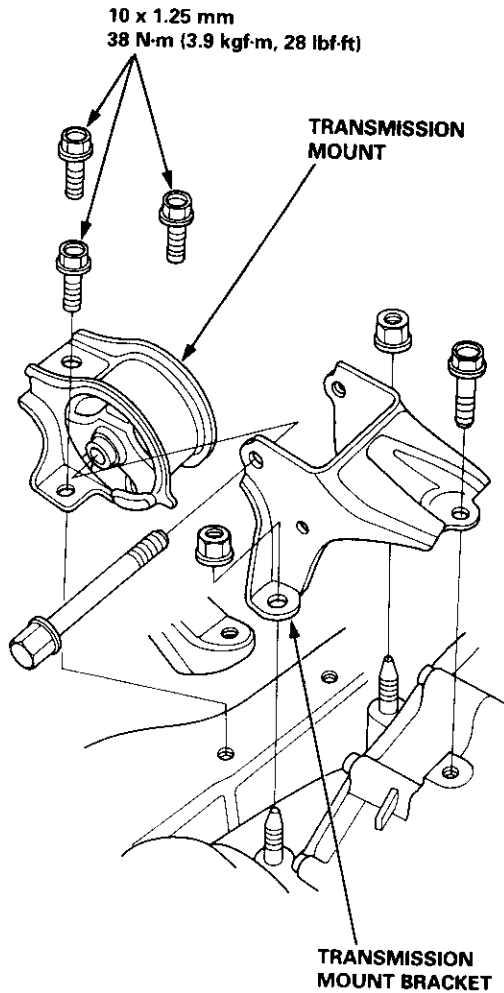

Except CVT:

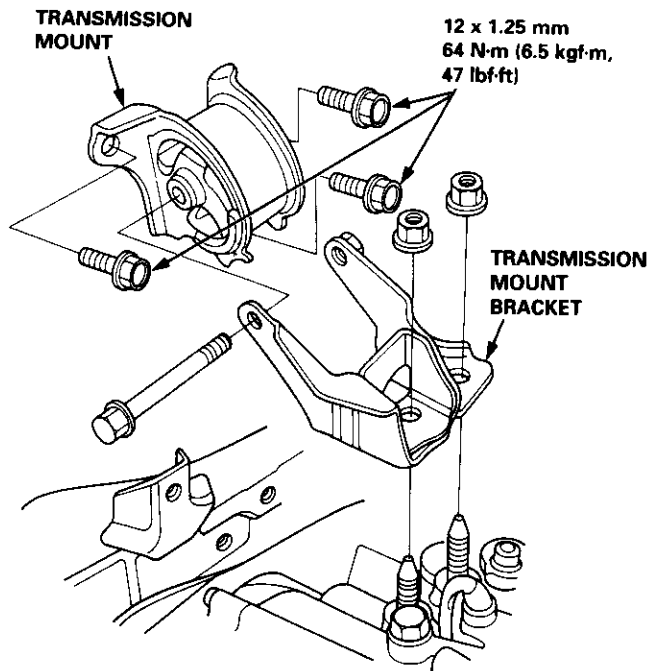

2. Install the upper bracket, then tighten the nuts in the numbered sequence shown (① - ②).

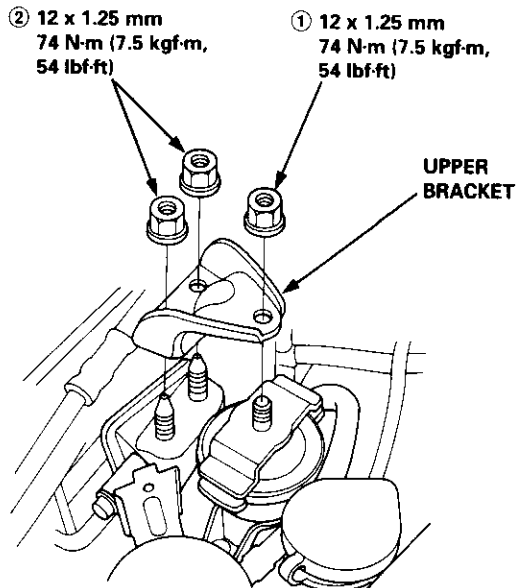



3. Install the rear mount bracket, then tighten the bolts in the numbered sequence shown (① - ③).

CVT:

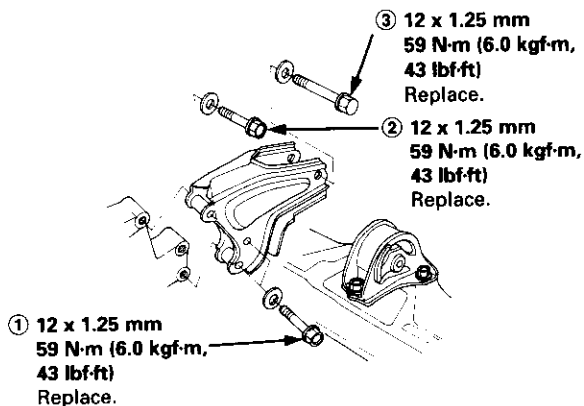

Except CVT:

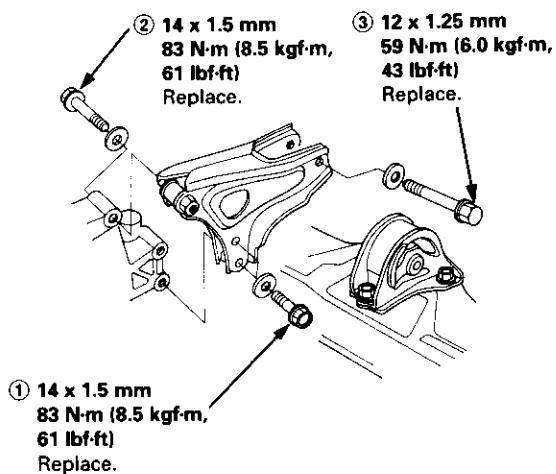

4. Tighten the bolt/nuts on the transmission mount bracket in the numbered sequence shown (① - ②).

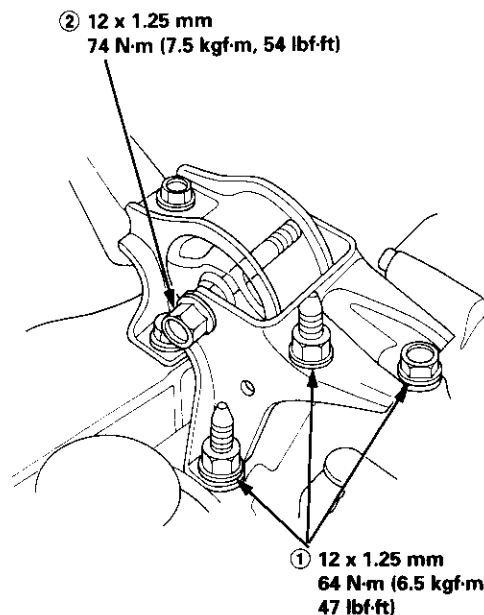

5. Tighten the bolts on the right front mount/bracket in the numbered sequence shown (① - ②).

CVT:

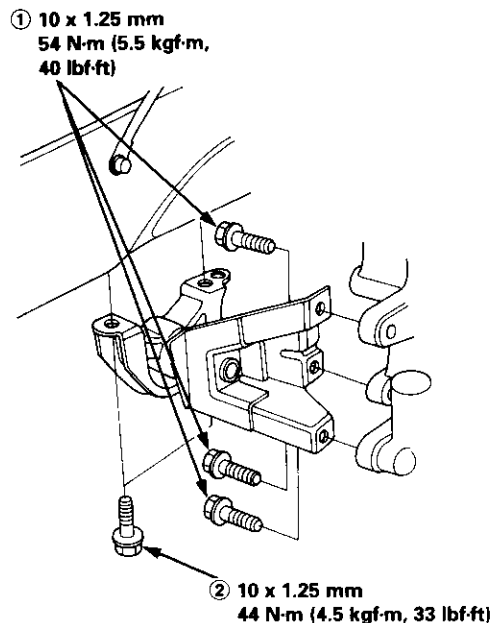

(cont'd)

Engine Removal/Installation

Installation (cont'd)

Except CVT:

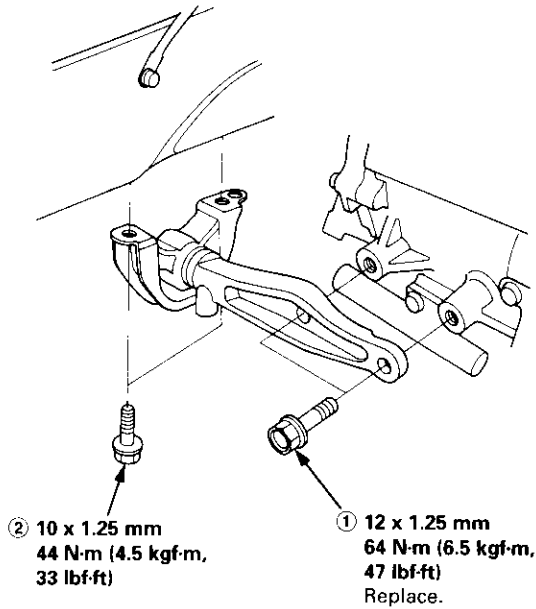

6. Tighten the bolts/nut on the left front mount in the numbered sequence shown (① - ③).

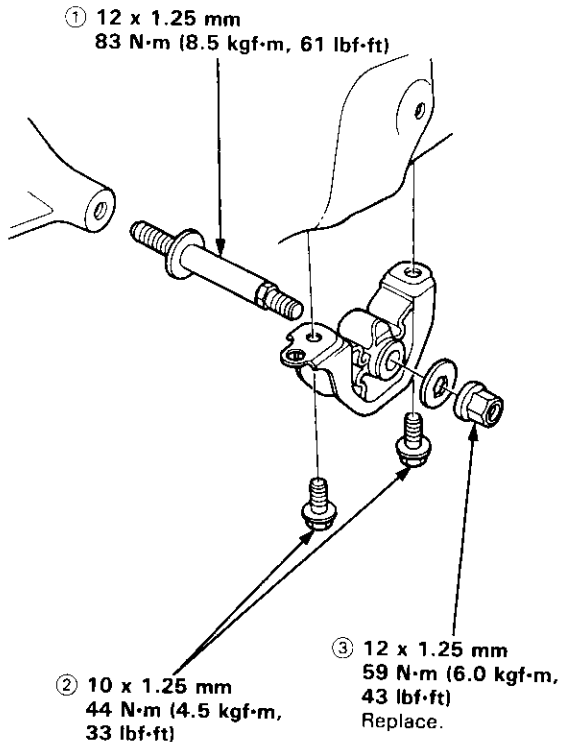

7. Perform the following:

- Clean the areas where the driveshaft(s) and the intermediate shaft contact the transmission (differential) thoroughly with solvent or carburetor cleaner, and dry with compressed air.
- Check that the set rings on the ends of the driveshaft and intermediate shaft click into place.
CAUTION: Use new set rings.
- Adjust the shift cable (see section 14).
- Adjust the throttle cable (see section 11).
- Adjust the cruise control cable (see section 23).
- Refill the engine with engine oil (see page 8-6).
- Refill the transmission with fluid (see section 13, 14).
- Refill the radiator with engine coolant (see page 10-7).
- Bleed air from the cooling system with the heater valve open (see page 10-7).
- Clean the battery posts and cable terminals with sandpaper, assemble them, then apply grease to prevent corrosion.
- Inspect for fuel leakage (see section 11).
After assembling the fuel line, turn on (II) the ignition switch (do not operate the starter) so that the fuel pump runs for approximately two seconds and the fuel line pressurizes. Repeat this operation two or three times, then check for fuel leakage at any point in the fuel line.



Mount and Bracket Bolts/Nuts Torque Value Specifications:

- A: 10 x 1.25 mm
64 N·m (6.5 kgf·m, 47 lbf·ft)
- B: 10 x 1.25 mm
44 N·m (4.5 kgf·m, 33 lbf·ft)
- C: 12 x 1.25 mm
83 N·m (8.5 kgf·m, 61 lbf·ft)
- D: 12 x 1.25 mm
59 N·m (6.0 kgf·m, 43 lbf·ft)
Replace.

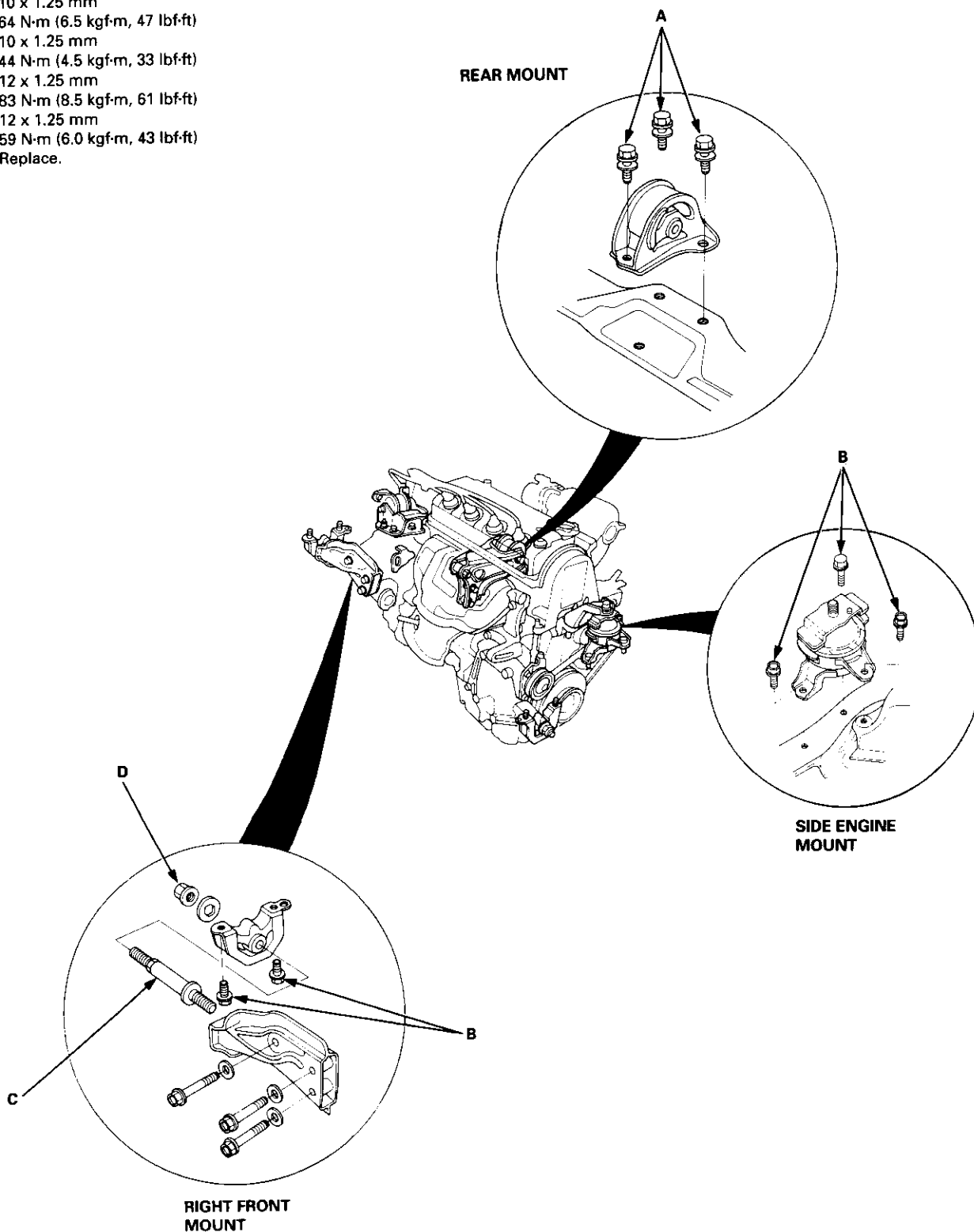

Cylinder Head/Valve Train D16Y5, D16Y7, D16Y8 engines

Special Tools	6-2	Cylinder Head	
VTEC Control System		Illustrated Index	6-23
Troubleshooting Flowchart	6-3	Removal	6-27
VTEC Solenoid Valve		Warpage	6-40
Inspection	6-6	Installation	6-45
VTEC Rocker Arms		Rocker Arms	
Manual Inspection		Removal	6-30
(D16Y5 engine)	6-7	Disassembly/Reassembly	6-31
Manual Inspection		Rocker Arms and Lost Motion Assemblies	
(D16Y8 engine)	6-7	Inspection (D16Y5, D16Y8	
Inspection Using Special Tools		engines)	6-34
(D16Y5 engine)	6-8	Rocker Arms and Shafts	
Inspection Using Special Tools		Clearance Inspection	6-35
(D16Y8 engine)	6-10	Camshaft	
Valve Clearance		Inspection	6-36
Adjustment	6-12	Valves, Valve Springs and Valve Seals	
Valve Seals		Removal	6-38
Replacement (Cylinder head removal		Valve Guides	
not required)	6-14	Valve Movement	6-39
Crankshaft Pulley and Pulley Bolt		Replacement	6-41
Replacement	6-16	Reaming	6-43
Timing Belt		Valve Seats	
Illustrated Index	6-17	Reconditioning	6-40
Inspection	6-18	Valves	
Tension Adjustment	6-18	Installation	6-43
Removal	6-19	Camshaft/Rocker Arms and	
Installation	6-20	Camshaft Seal/Pulley	
Crankshaft Speed Fluctuation (CKF) Sensor		Installation	6-44
Replacement	6-22		



Special Tools

Ref. No.	Tool Number	Description	Qty	Page Reference
①	07HAH - PJ7010B	Valve Guide Reamer, 5.5 mm	1	6-43
②	07JAA - 001010A	Socket, 17 mm	1	6-16
③	07JAB - 001020A	Holder Handle	1	6-16
④	07LAJ - PR3020B	Air Stopper	1	6-8, 10
⑤	07NAB - 001040A	Holder Attachment, 50 mm	1	6-16
⑥	07NAJ - P07010A	Pressure Gauge Adapter	1	6-4
⑦	07406 - 0020201	A/T Pressure Hose	1	6-4
or ⑦ - 1	07MAJ - PY4011A	A/T Pressure Hose, 2,210 mm	1	6-4
and ⑦ - 2	07MAJ - PY40120	A/T Pressure Adapter	1	6-4
⑧	07406 - 0070300	A/T Low Pressure Gauge W/Panel	1	6-4
⑨	07742 - 0010100	Valve Guide Driver, 5.5 mm	1	6-41, 42



①



②

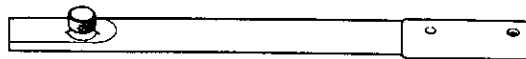

③



④

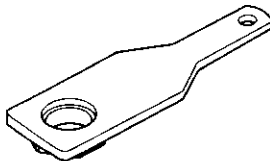

⑤

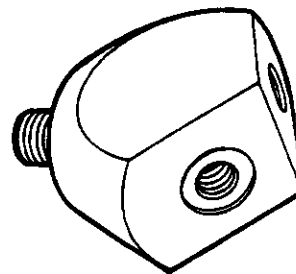

⑥

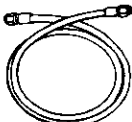

⑦
⑦ - 1

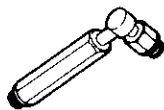

⑦ - 2



⑧



⑨

VTEC Control System



Troubleshooting Flowchart

P1259 The scan tool indicates Diagnostic Trouble Code (DTC) P1259: A problem in the VTEC Pressure Switch circuit or VTEC Solenoid Valve circuit.

Refer to page 11-38 through 11-55 before troubleshooting.

— The MIL has been reported on.
— DTC P1259 is stored.

Check the VTEC Control System:

1. Do the engine control module (ECM)/powertrain control module (PCM) Reset Procedure (see section 11).
2. Start the engine.
3. Warm up the engine to normal operating temperature (cooling fan comes on).
4. Do the Road Test.*

*** Road Test:**
Accelerate in 1st gear to an engine speed over 3,000 rpm (D16Y5 engine) or 6,000 rpm (D16Y8 engine). Hold that engine speed for at least two seconds. If DTC P1259 is not repeated during the first road test, repeat this test two more times.

Is DTC P1259 indicated?

NO
Intermittent failure, system is OK at this time. Check for poor connections or loose wires at VTEC pressure switch, VTEC solenoid valve and ECM/PCM.

YES

Test the VTEC Pressure Switch:

1. Turn the ignition switch OFF.
2. Disconnect the VTEC Pressure switch 2P connector.
3. Check for continuity between VTEC pressure switch 2P connector terminal No. 1 and No. 2.

Is there continuity?

NO
Replace the VTEC pressure switch.

YES

Test the VTEC Pressure Switch Wire:

1. Turn the ignition switch ON (II).
2. Measure the voltage between VTEC pressure switch 2P connector No. 1 and body ground.

Is there battery voltage?

NO
Inspect for an open or short to ground in the wire between the VTEC pressure switch and ECM/PCM ('96 - '98: C15, '99 - '00: C10). If the wire is OK, substitute a known-good ECM/PCM and recheck.

YES

(To page 6-4)

VTEC PRESSURE SWITCH 2P CONNECTOR

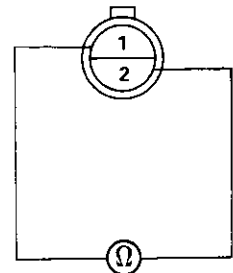

Terminal side of male terminals

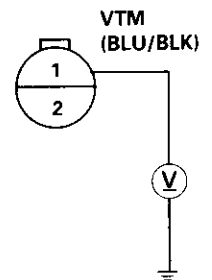

Wire side of female terminals

(cont'd)

VTEC Control System

Troubleshooting Flowchart (cont'd)

(From page 6-3)

Test the VTEC Pressure Switch Wire:
Measure voltage across the VTEC pressure switch 2P connector.

Is there battery voltage?

NO

- Repair open in the wire between VTEC pressure switch and G101.
- If the wire is OK, substitute a known-good ECM/PCM and recheck.

YES

Test the VTEC Solenoid Valve:
1. Turn the ignition switch OFF.
2. Disconnect the VTEC solenoid valve 1P connector.
3. Check for continuity between the VTEC solenoid valve 1P connector terminal No. 1 and body ground.

Is there 14 - 30 Ω?

NO

Replace VTEC solenoid valve.

YES

Test the VTEC Solenoid Valve:
1. Remove the VTEC pressure switch and install the special tool as shown, then reinstall the VTEC pressure switch.
2. Reconnect the VTEC solenoid valve 1P connector and VTEC pressure switch 2P connector.
3. Connect the tachometer (see section 11).
4. Start the engine.
5. Warm up engine to normal operating temperature (cooling fan comes on).
6. Check oil pressure at engine speeds D16Y5 engine: 1,000 and 3,000 rpm, D16Y8 engine: 1,000, 3,000 and 5,000 rpm.

Is pressure below 49 kPa (0.5 kgf/cm², 7 psi)?

NO

Inspect the VTEC solenoid valve (see page 6-6).

YES

(To page 6-5)

VTEC PRESSURE SWITCH 2P CONNECTOR

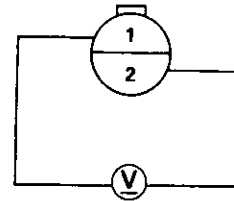

Wire side of female terminals

VTEC SOLENOID VALVE 1P CONNECTOR

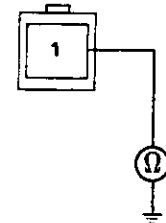

Terminal side of male terminal

A/T LOW PRESSURE GAUGE W/PANEL
07406-0070300

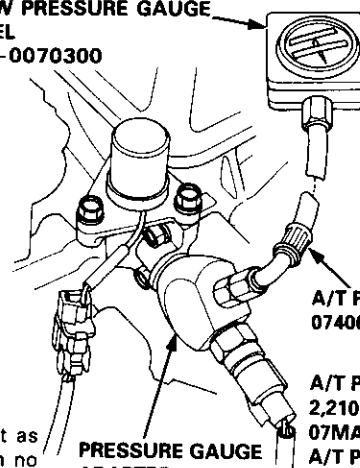

A/T PRESSURE HOSE
07406-0020201

or

A/T PRESSURE HOSE,
2,210 mm

07MAJ-PY4011A and
A/T PRESSURE ADAPTER
07MAJ-PY40120

PRESSURE GAUGE ADAPTER
07NAJ-P07010A

NOTE: Keep measuring time as short as possible because engine is running with no load (less than one minute).



(From page 6-4)

Test the VTEC Solenoid Valve:

1. Turn the ignition switch OFF.
2. Disconnect the VTEC solenoid valve 1P connector.
3. Attach the battery positive terminal to the VTEC solenoid valve terminal.
4. Start the engine and check the oil pressure at engine speed of 5,000 rpm.

Is the pressure above 390 kPa (4.0 kgf/cm², 57 psi)?

NO → **Inspect the VTEC solenoid valve (see page 6-6).**

YES

Test the VTEC Pressure Switch:

With the battery positive terminal connected to the VTEC solenoid valve, measure voltage between the ECM/PCM connector terminal '96 - 98: C15, '99 - 00: C10 and body ground.

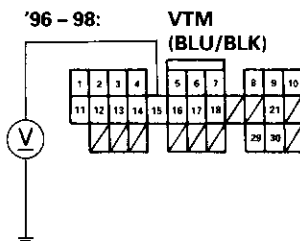

VTEC SOLENOID VALVE 1P CONNECTOR

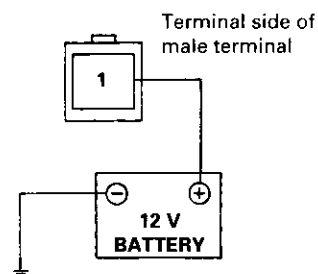

ECM/PCM CONNECTOR C (31P)

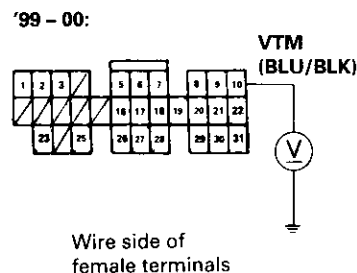

Is there battery voltage above 5,000 rpm?

NO → **Replace the VTEC pressure switch.**

YES

Test the VTEC Solenoid Valve Wire:

1. Turn the ignition switch OFF.
2. Check for continuity between the VTEC solenoid valve 1P connector terminal and the ECM/PCM connector terminal '96 - 98: A8, '99 - 00: B12.

'99 - 00: VTEC SOLENOID VALVE 1P CONNECTOR

ECM/PCM CONNECTOR B (25P)

VTS (GRN/YEL)

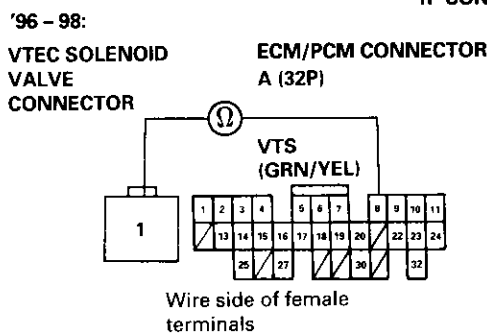

Is there continuity?

NO → **Repair open in the wire between the ECM/PCM ('96 - 98: A8, '99 - 00: B12) and VTEC solenoid valve connector.**

Test the VTEC Solenoid Valve Wire:

Check for continuity between the VTEC solenoid valve 1P connector terminal and body ground.

Is there continuity?

YES → **Repair short in the wire between the ECM/PCM ('96 - 98: A8, '99 - 00: B12) and VTEC solenoid valve connector.**

VTEC SOLENOID VALVE 1P CONNECTOR

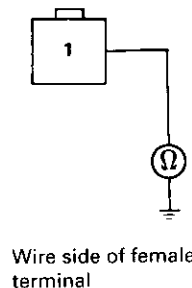

Substitute a known-good ECM/PCM and recheck. If symptom/indication goes away, replace the original ECM/PCM.

VTEC Solenoid Valve

Inspection

1. Disconnect the 1P connector from the VTEC solenoid valve.
2. Measure resistance between the terminal and body ground.

Resistance: 14 – 30 Ω

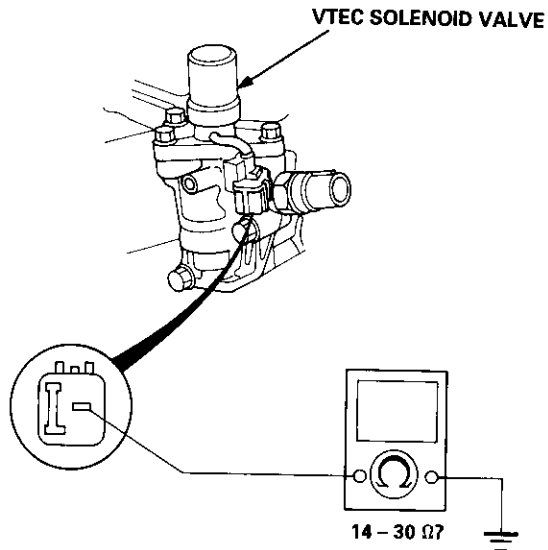

3. If the resistance is within specifications, remove the VTEC solenoid valve assembly from the cylinder head, and check the VTEC solenoid valve filter for clogging.

- If there is clogging, replace the engine oil filter and the engine oil.

VTEC SOLENOID VALVE ASSEMBLY

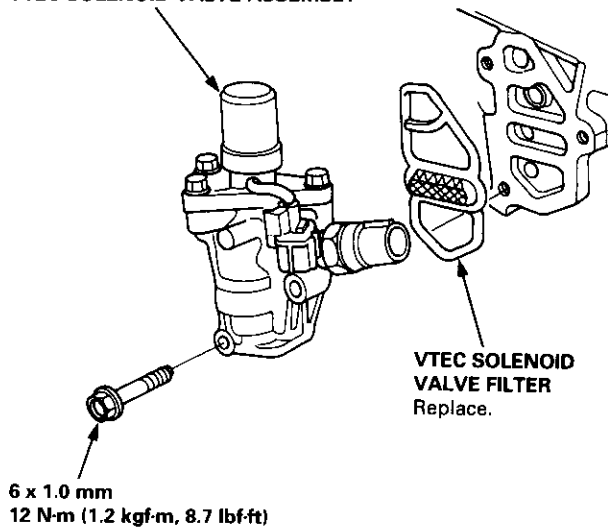

4. If the filter is not clogged, push the VTEC solenoid valve with your finger and check its movement.

- If the VTEC solenoid valve is normal, check the engine oil pressure.

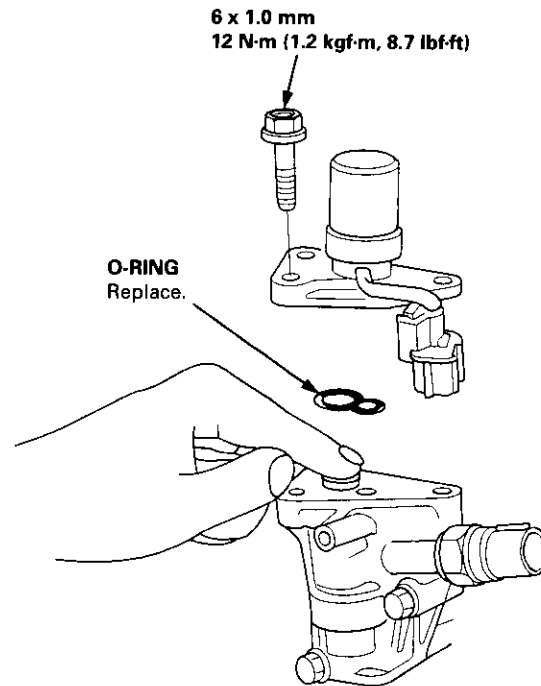

VTEC Rocker Arms



Manual Inspection (D16Y5 engine)

1. Set the No. 1 piston at TDC.
2. Remove the cylinder head cover.

NOTE: Refer to page 6-46 when installing the cylinder head cover.
3. Move the intake secondary rocker arm on the No. 1 cylinder manually.
4. Check that the intake secondary rocker arm moves independently of the primary intake rocker arm.

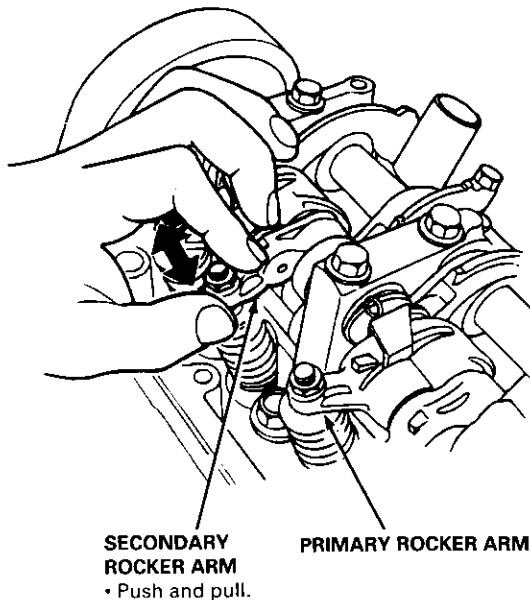

5. Check the intake secondary rocker arm of each cylinder at TDC.
 - If the intake secondary rocker arm does not move, remove the primary and secondary intake rocker arms as an assembly and check that the pistons in the secondary and primary rocker arms move smoothly.
 - If any rocker arm needs replacing, replace the primary and secondary rocker arms as an assembly.

Manual Inspection (D16Y8 engine)

1. Set the No. 1 piston at TDC.
2. Remove the cylinder head cover.

NOTE: Refer to page 6-46 when installing the cylinder head cover.
3. Push the intake mid rocker arm on the No. 1 cylinder manually.
4. Check that the intake mid rocker arm moves independently of the primary and secondary intake rocker arms.

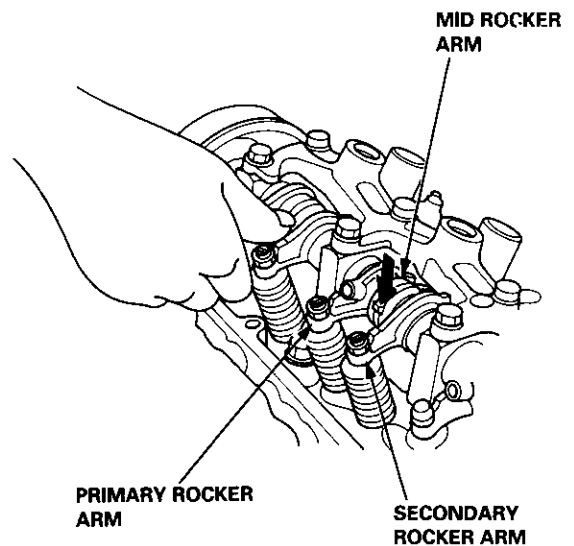

5. Check the intake mid rocker arm of each cylinder at TDC.
 - If the intake mid rocker arm does not move, remove the mid, primary and secondary intake rocker arms as an assembly and check that the pistons in the mid and primary rocker arms move smoothly.
 - If any rocker arm needs replacing, replace the primary, mid, and secondary rocker arms as an assembly.

VTEC Rocker Arms

Inspection Using Special Tools (D16Y5 engine)

CAUTION:

- Before using the Valve Inspection Tool, make sure that the air pressure gauge on the air compressor indicates over 400 kPa (4 kgf/cm², 57 psi).
- Inspect the valve clearance before rocker arm inspection.
- Cover the timing belt with a shop towel to protect the belt.
- Check the intake primary rocker arm of each cylinder at TDC.

1. Remove the cylinder head cover.

NOTE: Refer to page 6-46 when installing the cylinder head cover.

2. Plug the relief hole with the special tool.

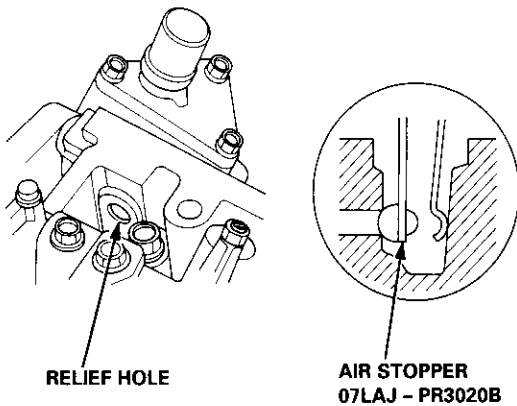

3. Remove the sealing bolt from the inspection hole and connect the an air pressure regulator with a 0 - 100 psi gauge.

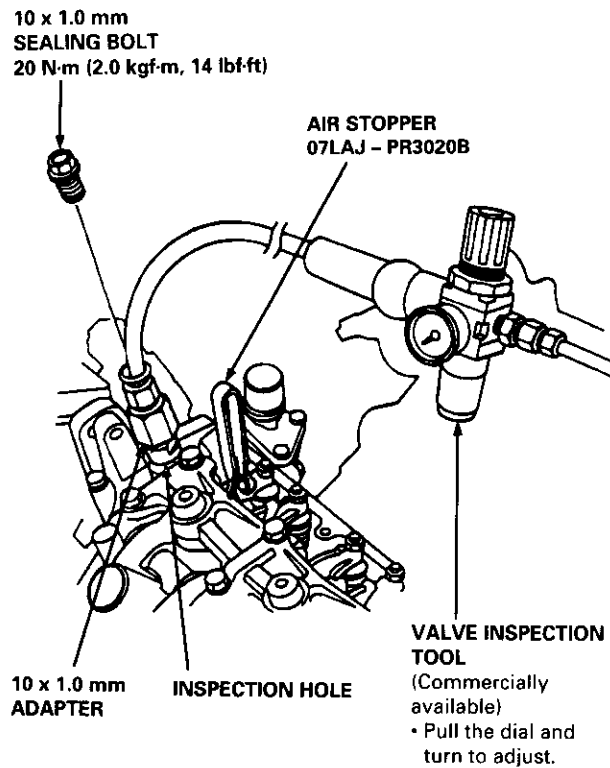

4. Loosen the regulator valve on the valve inspection tool and apply the specified air pressure.

Specified Air Pressure:
250 kPa (2.5 kgf/cm², 36 psi)



5. With the specified air pressure applied, push up the timing plate; the synchronizing piston will pop out and engage the intake secondary rocker arm. Visually check the engagement of the synchronizing piston.

NOTE:

- The synchronizing piston can be seen in the gap between the secondary and primary rocker arms.
- With the timing plate engaged in the groove on the timing piston, the piston is locked in the pushed out position.

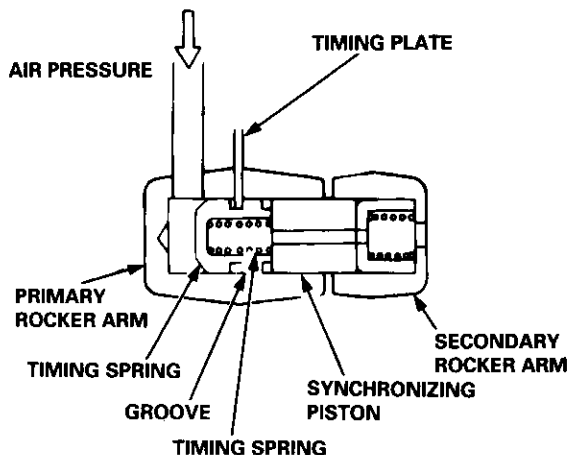
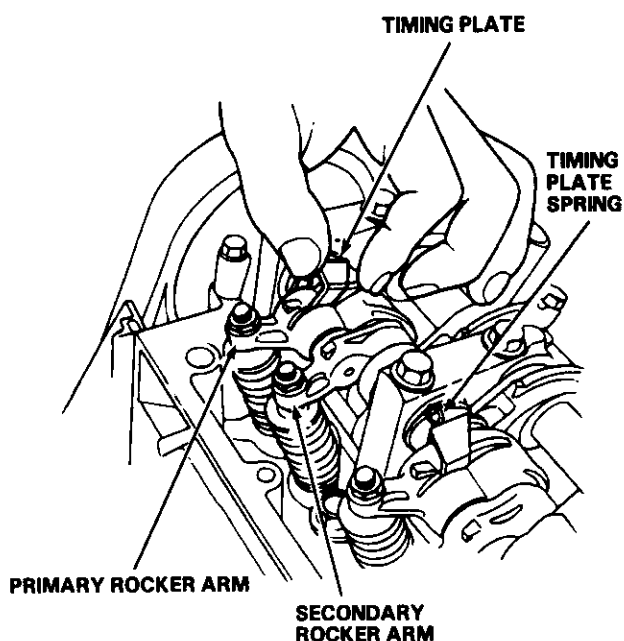

6. Stop applying air pressure and push up the timing plate; the synchronizing piston will snap back to its original position. Visually check the disengagement of the synchronizing pistons.

NOTE:

- When the timing plate is pushed up, it releases the timing piston, letting the return spring move the synchronizing piston to its original position.
7. Replace the intake rocker arms as an assembly if either does not work correctly.

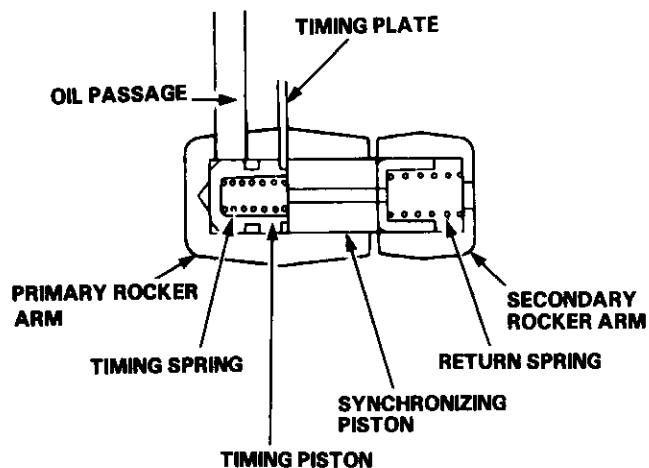

8. Remove the special tools.
9. After inspection, check that the malfunction indicator lamp (MIL) does not come on.

VTEC Rocker Arms

Inspection Using Special Tools (D16Y8 engine)

CAUTION:

- Before using the Valve Inspection Tool, make sure that the air pressure gauge on the air compressor indicates over 400 kPa (4 kgf/cm², 57 psi).
- Inspect the valve clearance before rocker arm inspection.
- Cover the timing belt with a shop towel to protect the belt.
- Check the intake primary rocker arm of each cylinder at TDC.

1. Remove the cylinder head cover.

NOTE: Refer to page 6-46 when installing the cylinder head cover.

2. Plug the relief hole with the special tool.

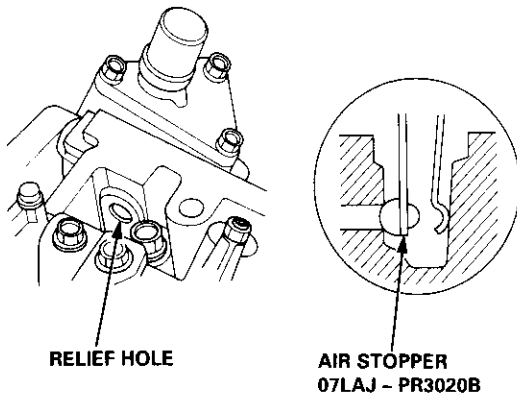

3. Remove the sealing bolt from the inspection hole and connect an air pressure regulator with a 0 - 100 psi gauge.

10 x 1.0 mm
SEALING BOLT
20 N·m (2.0 kgf·m, 14 lbf·ft)

AIR STOPPER
07LAJ - PR3020B

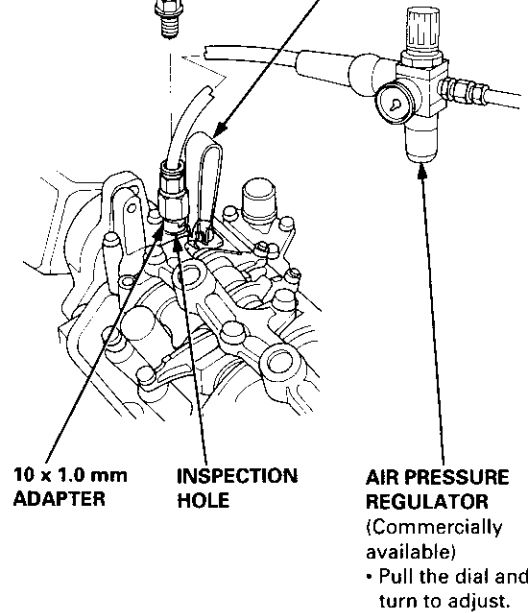



- Loosen the regulator valve on the valve inspection tool and apply the specified air pressure.

Specified Air Pressure:
250 kPa (2.5 kgf/cm², 36 psi)

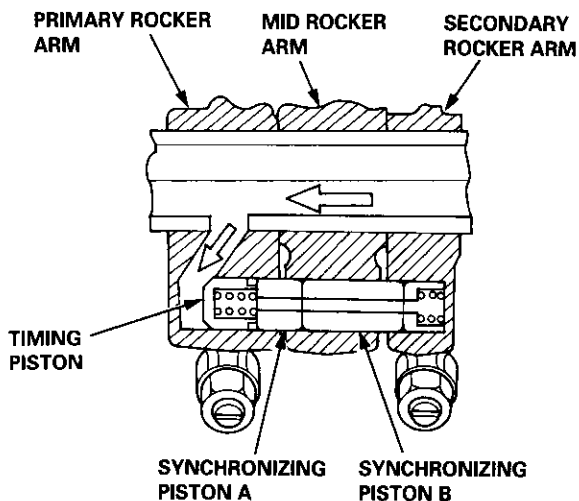

- Make sure that the intake primary and secondary rocker arms are mechanically connected by the piston and that the mid rocker arm does not move when pushed manually.

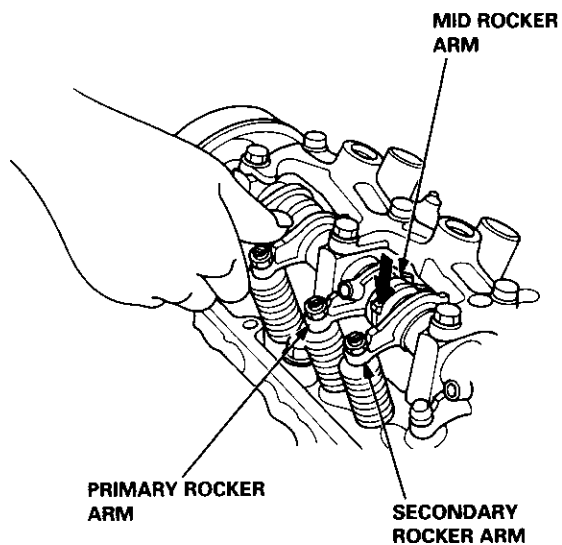

- If any intake mid rocker arm moves independently of the primary and secondary rocker arms, replace the rocker arms as a set.

- Remove the special tools.
- Use a 10 mm diameter rod to depress each lost motion assembly through its full movement. Replace any lost motion assembly that does not move smoothly.

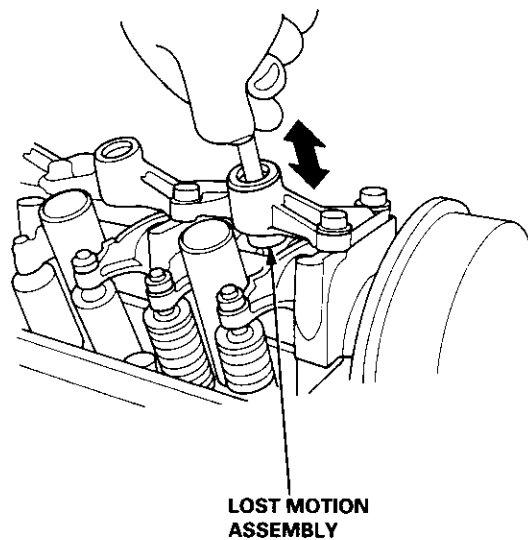

- After inspection, check that the MIL does not come on.

Valve Clearance

Adjustment

NOTE:

- Valves should be adjusted only when the cylinder head temperature is less than 100°F (38°C).
- After adjusting, retorque the crankshaft pulley bolt (see page 6-16).

1. Remove the cylinder head cover.

NOTE: Refer to page 6-46 when installing the cylinder head cover.

2. Remove the upper cover (see page 6-19).
3. Set the No. 1 piston at TDC. The "UP" mark on the cam-shaft pulley should be at top, and the TDC marks should align with the cylinder head surface.

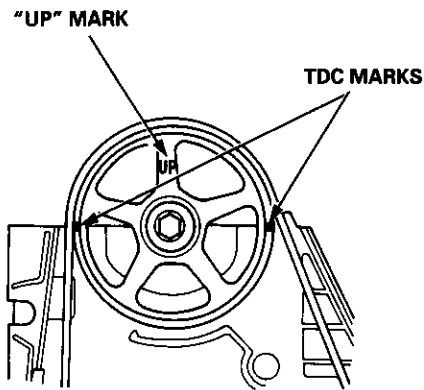

4. Adjust valves on No. 1 cylinder.

Intake: 0.18 – 0.22 mm (0.007 – 0.009 in)

Exhaust: 0.23 – 0.27 mm (0.009 – 0.011 in)

5. Loosen the locknut, and turn the adjustment screw until the feeler gauge slides back and forth with a slight amount of drag.

D16Y7 engine:

CAUTION: Do not overtighten the locknuts; the rocker arms are made of aluminum.

INTAKE and EXHAUST VALVE LOCKNUTS

18 N·m (1.8 kgf·m, 13 lbf·ft)

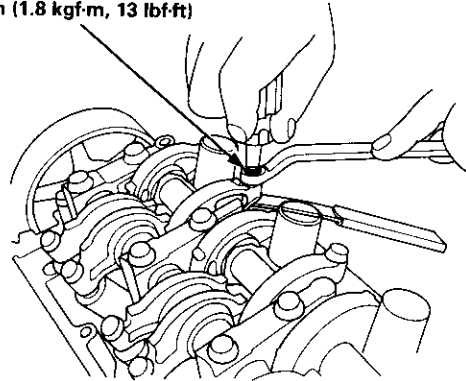

D16Y5, D16Y8 engines:

INTAKE and EXHAUST VALVE LOCKNUTS

20 N·m (2.0 kgf·m, 14 lbf·ft)

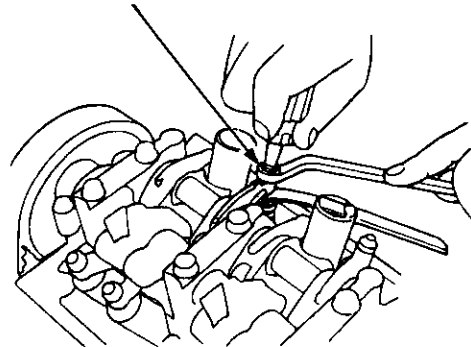

Adjusting screw locations:

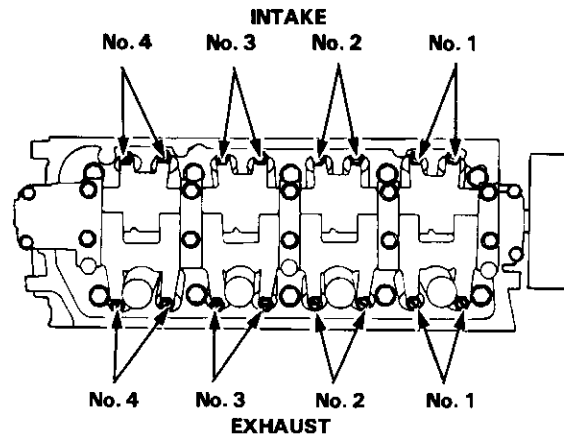



6. Tighten the locknut, and check the clearance again. Repeat the adjustment if necessary.

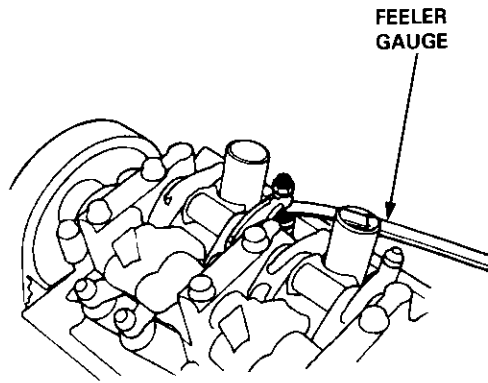

7. Rotate the crankshaft 180° counterclockwise (camshaft pulley turns 90°). The "UP" mark should be on the exhaust side. Adjust valves on No. 3 cylinder.

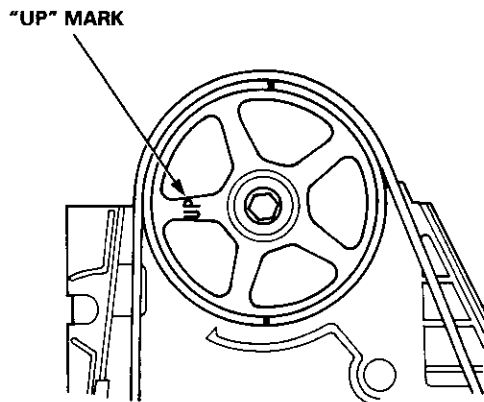

8. Rotate the crankshaft 180° counterclockwise to bring No. 4 piston to TDC. Both TDC grooves are once again visible. Adjust valves on No. 4 cylinder.

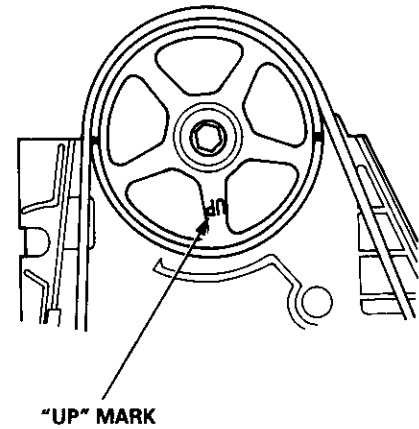

9. Rotate the crankshaft 180° counterclockwise to bring No. 2 piston to TDC. The "UP" mark should be on the intake side. Adjust valves on No. 2 cylinder.

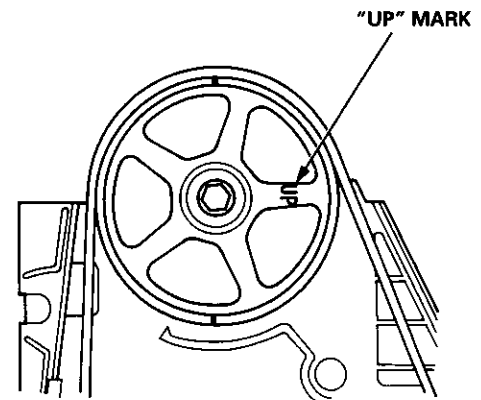

Valve Seals

Replacement (Cylinder head removal not required)

NOTE: Cylinder head removal is not required in this procedure.

The procedure shown below applies when using the in-car valve spring compressor (Snap-on YA8845 with YA8845 - 2 A 7/8" attachment).

▲ WARNING Always wear approved eye protection when using the in-car valve spring compressor.

1. Turn the crankshaft so that the No. 1 and the No. 4 pistons are at top dead center (TDC).

2. Remove the cylinder head cover and the rocker arm assembly.

NOTE:

- Refer to page 6-30 for rocker arm assembly removal.
- When removing or installing the rocker arm assembly, do not remove the camshaft holder bolts. The bolts will keep the holders, springs and rocker arms on the shaft.
- Refer to page 6-46 when installing the cylinder head cover.

3. Remove the fuel injectors and the wire harness.

4. Using the 8 mm bolts supplied with the tool, mount the two uprights to the cylinder head at the end camshaft holders. The uprights fit over the camshaft as shown.

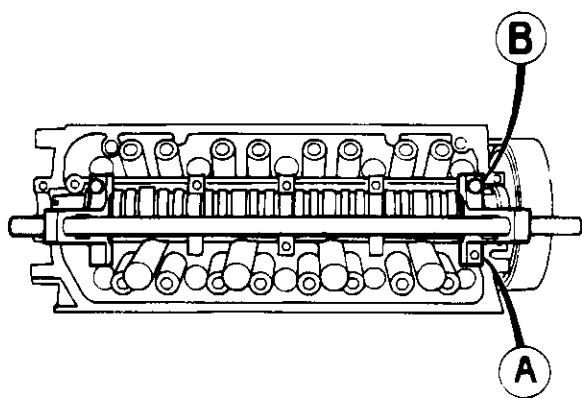

5. Insert the cross shaft through the top hole of the two uprights.

Intake Valve Seals:

6. Select the 7/8 in diameter short compressor attachment, and fasten the attachment to the No. 4 hole of the lever arm with the speed pin supplied.
7. Insert an air adaptor into the spark plug hole. Pump air into the cylinder to keep the valve closed while compressing springs and removing the valve keepers.
8. Put shop towels over the oil passages to prevent the valve keepers from falling into the cylinder head.

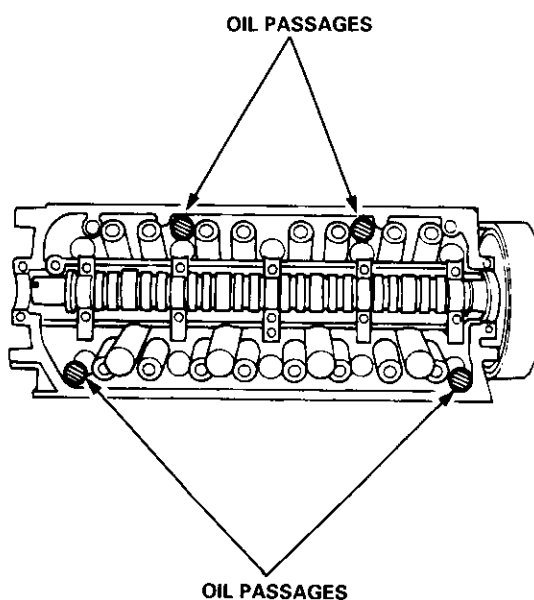

9. Position the lever arm under the cross shaft so the lever is perpendicular to the shaft and the compressor attachment rests on top of the retainer for the spring being compressed. Use the front position slot on the lever as shown.

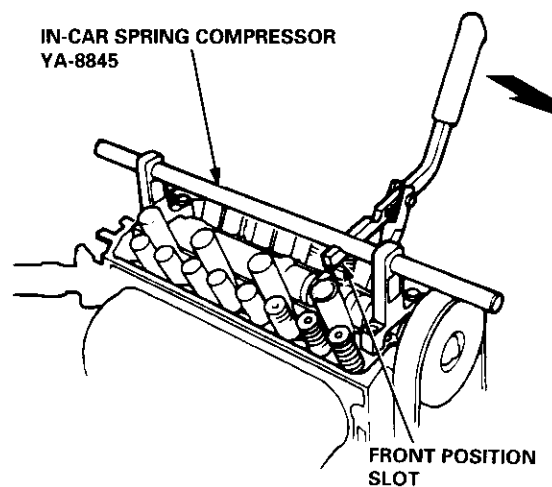



10. Using a downward motion on the lever arm, compress the valve spring and remove the keepers from the valve stem. Slowly release pressure on the spring.
11. Remove the valve seals (see page 6-38).
12. Install the valve seals (see page 6-43).
13. Install the springs, the retainers and the keepers in reverse order of removal.

Exhaust Valve Seals:

14. Select the 7/8 in. diameter short compressor attachment, and fasten the attachment to the No. 2 hole of the lever arm with the speed pin supplied.
15. Position the lever arm under the cross shaft so the lever is perpendicular to the shaft and the compressor attachment rests on top of the retainer for the spring being compressed. Use the front position slot on the lever as shown.

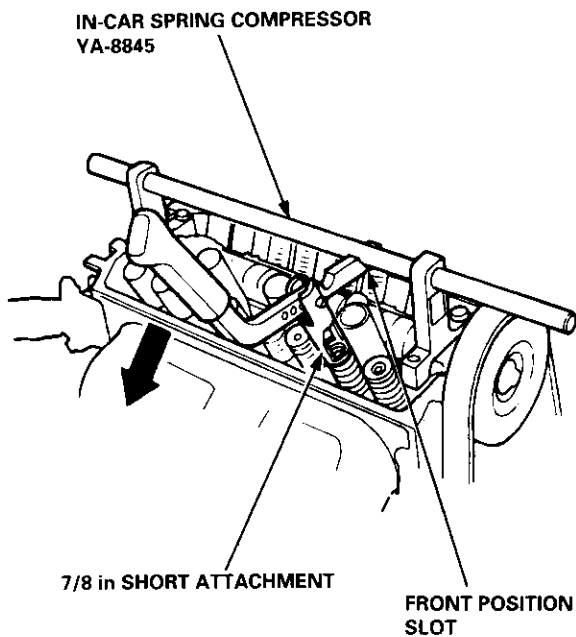

16. Using a downward motion on the lever arm, compress the valve spring and remove the keepers from the valve stem. Slowly release pressure on the spring.
17. Remove the valve seals (see page 6-38).
18. Install the valve seals (see page 6-43).
19. Install the springs, the retainers and the keepers in reverse order of removal.
20. Repeat steps 6 to 19 on the other cylinders.

Crankshaft Pulley and Pulley Bolt

Replacement

When installing and tightening the pulley, follow the procedure below.

Clean, remove any oil, and lubricate points shown below.

○: Clean

×: Remove any oil

●: Lubricate

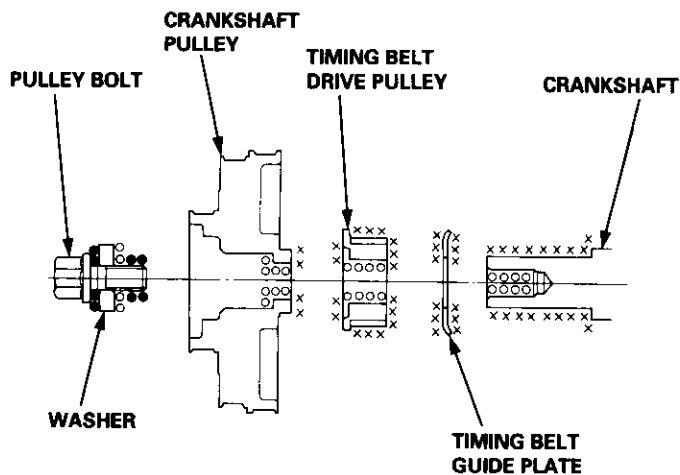

Crankshaft pulley bolt size and torque value:

14 x 1.25 mm

20 N·m (2.0 kgf·m, 14 lbf·ft) + 90°

NOTE: Do not use an impact wrench when installing.

HOLDER HANDLE
07JAB - 001020A

HOLDER ATTACHMENT, 50 mm
07NAB - 001040A

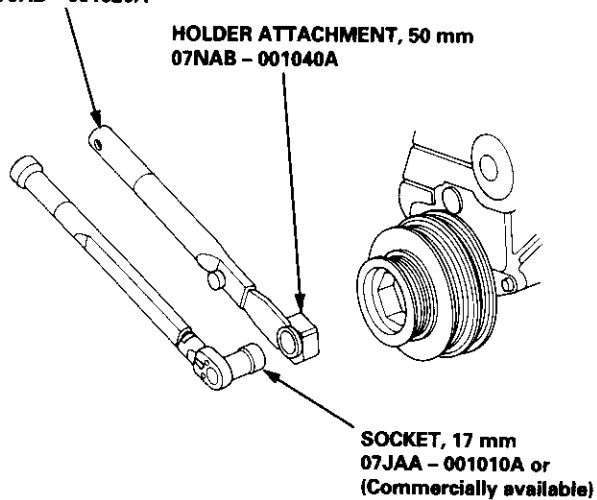

1. Tighten the pulley bolt to the specified torque.

Torque: 20 N·m (2.0 kgf·m, 14 lbf·ft)

2. Use a felt tip pen to mark the pulley bolt head and washer.

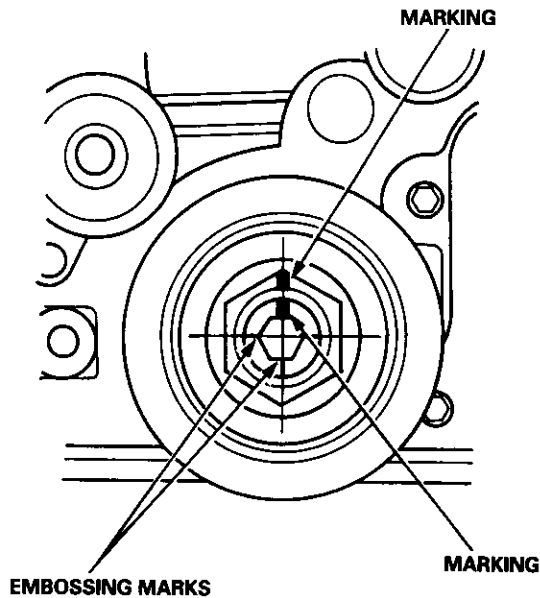

3. Tighten the pulley bolt an additional 90°.

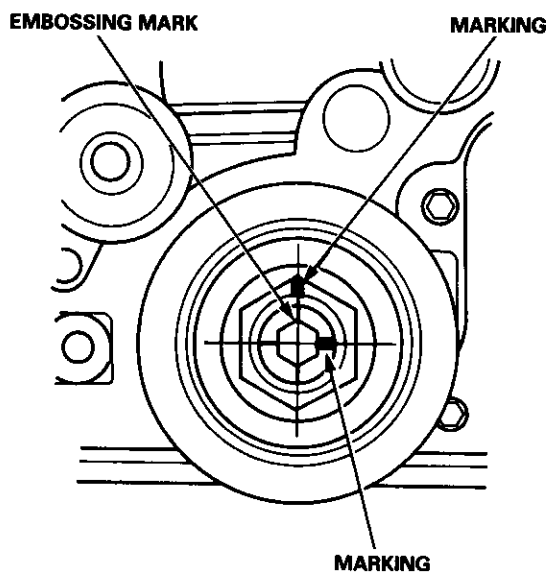



Timing Belt

Illustrated Index

NOTE:

- Refer to page 6-20 for how to position the crankshaft and pulley before installing the belt.
- Mark the direction of rotation on the belt before removing.
- Do not use the upper cover and lower cover for storing removed items.
- Clean the upper cover and lower cover before installing.
- Replace the camshaft seals and crankshaft seals if there is oil leakage.
- Refer to page 6-16 before installing the timing belt.

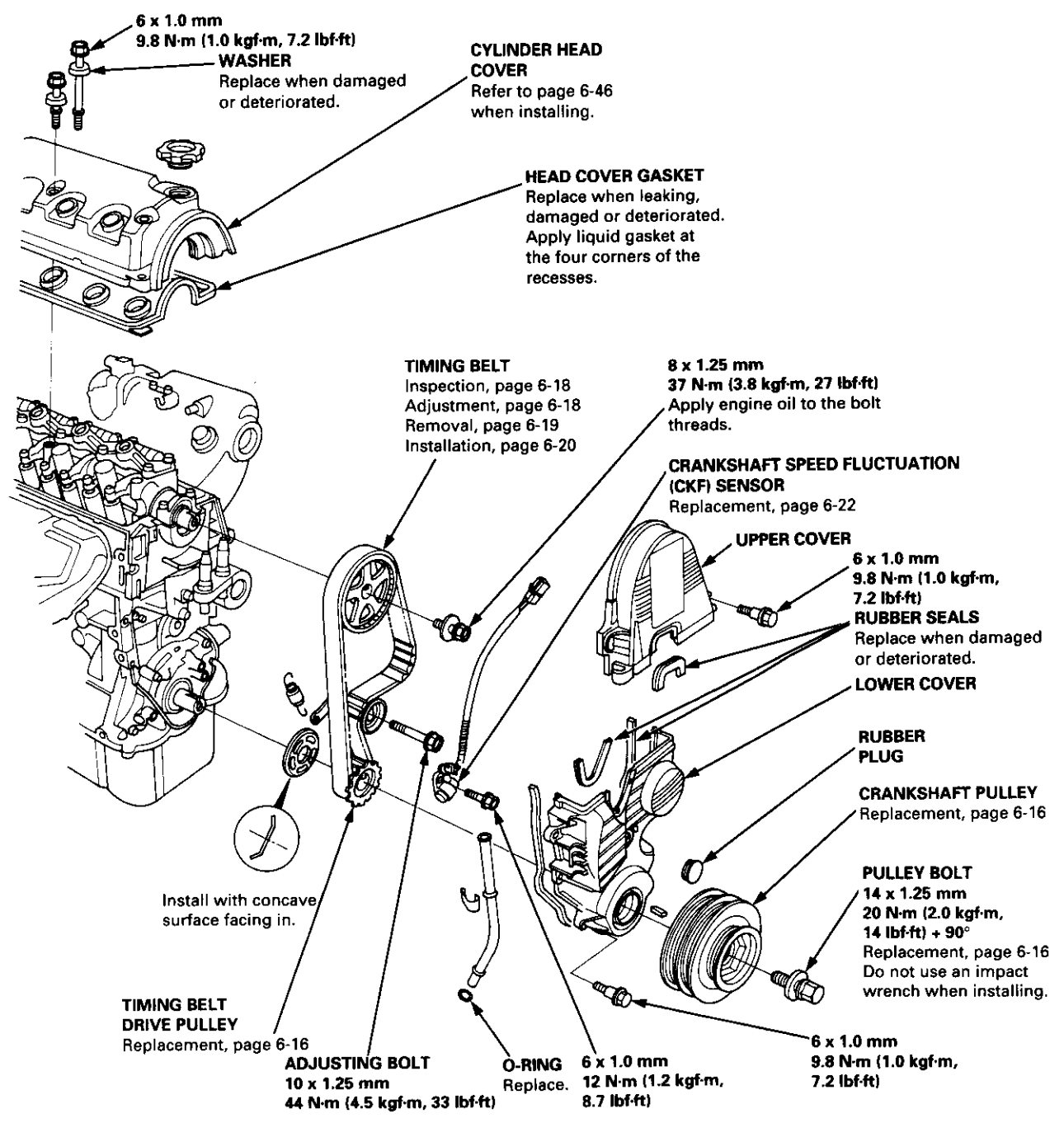

Timing Belt

Inspection

1. Remove the cylinder head cover.
 - Refer to page 6-46 when installing.
2. Remove the upper cover (see page 6-19).
3. Inspect the timing belt for cracks and oil or coolant soaking.

NOTE:

- Replace the belt if oil or coolant soaked.
- Remove any oil or solvent that gets on the belt.

Inspect this area for wear.

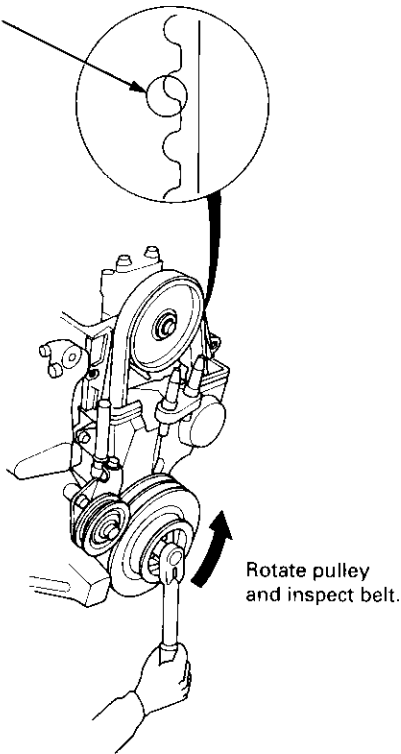

4. After inspecting, retorque the crankshaft pulley bolt (see page 6-16).

Tension Adjustment

CAUTION: Always adjust the timing belt tension with the engine cold.

NOTE:

- The tensioner is spring-loaded to apply tension to the belt automatically after making the following adjustment.
- Always rotate the crankshaft counterclockwise when viewed from the pulley side. Rotating it clockwise may result in improper adjustment of the belt tension.
- Inspect the timing belt before adjusting the belt tension.

1. Remove the cylinder head cover.
 - Refer to page 6-46 when installing.
2. Remove the upper cover (see page 6-19).
3. Rotate the crankshaft five or six revolutions to set the belt.
4. Set the No. 1 piston at TDC (see page 6-21).
5. Loosen the adjusting bolt 180°.

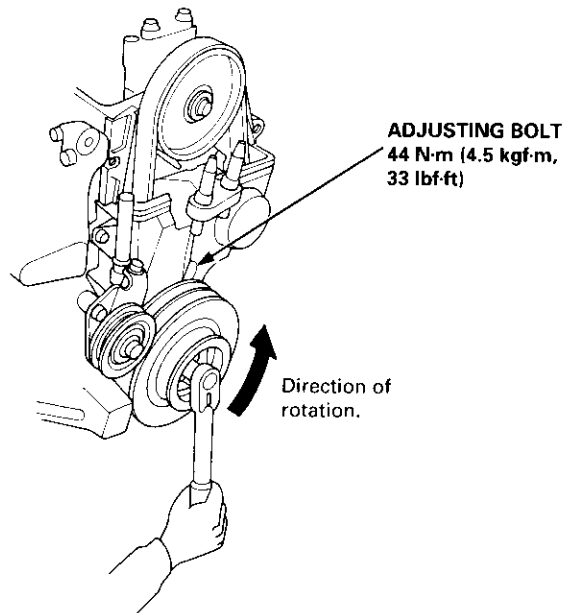

6. Rotate the crankshaft counterclockwise three teeth on the camshaft pulley.
7. Tighten the adjusting bolt.
8. After inspecting, retorque the crankshaft pulley bolt (see page 6-16).



Removal

NOTE:

- Replace the timing belt at 105,000 miles (168,000 km) according to the maintenance schedule (normal conditions/severe conditions).
If the vehicle is regularly driven in one or more of the following conditions, replace the timing belt at 60,000 miles (U.S.A.) 100,000 km (Canada).
 - In very high temperatures (over 110°F, 43°C).
 - In very low temperatures (under -20°F, -29°C).
- Turn the crankshaft pulley so the No. 1 piston is at top dead center (TDC) before removing the belt (see page 6-21).
- Inspect the water pump before installing the timing belt (see page 10-14).

1. Remove the splash shield (see page 5-7).
2. Loosen the mounting bolt and lock bolt, then remove the power steering (P/S) pump belt and pump.

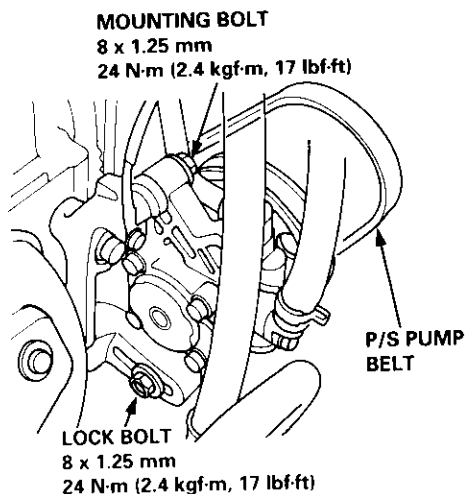

3. Loosen the idler pulley center nut and adjusting bolt, then remove the air conditioning (A/C) compressor belt (see page 5-6).
4. Loosen the mounting nut and lock bolt, then remove the alternator belt.

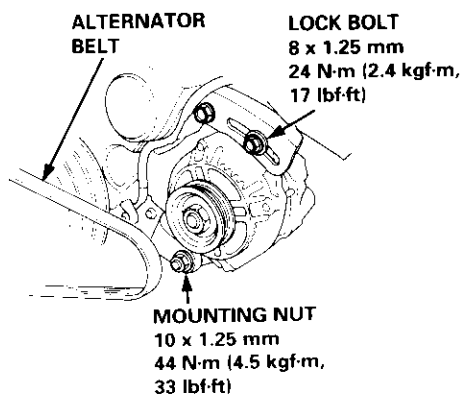

5. Remove the dipstick, then remove the upper cover and idler pulley bracket.

NOTE: Do not use the upper cover to store removed items.

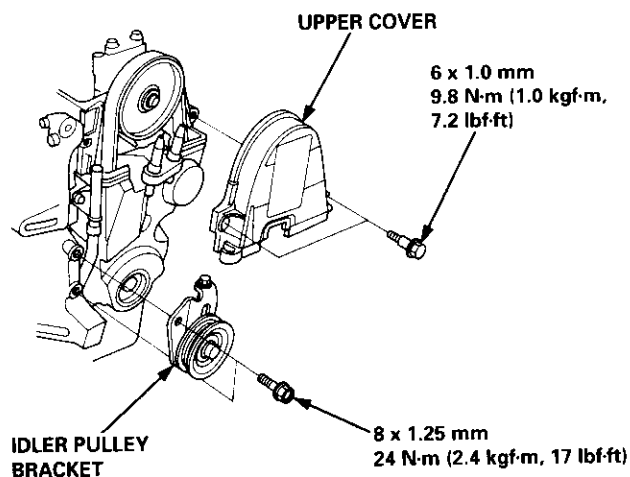

6. Remove the upper bracket (see page 6-29).

NOTE:

- Use a jack to support the engine before the upper bracket is removed.
- Make sure to place a cushion between the oil pan and the jack.

7. Remove the crankshaft pulley (see page 6-16).
8. Remove the lower cover and dipstick tube.

NOTE: Do not use the lower cover to store removed items.

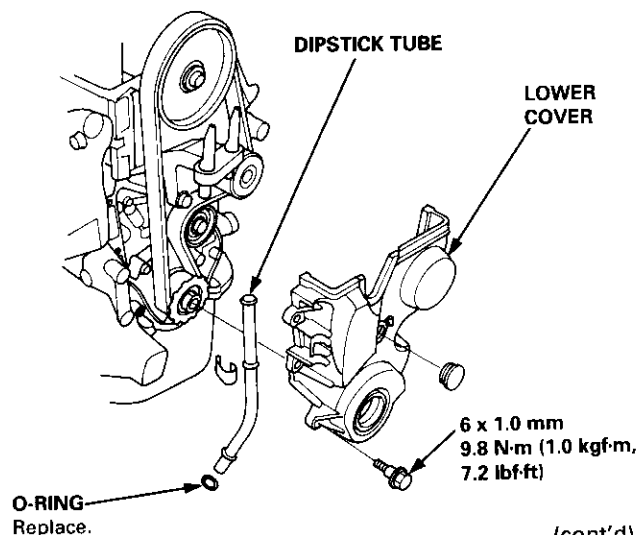

(cont'd)

Timing Belt

Removal (cont'd)

9. Remove the CKF sensor from the oil pump.

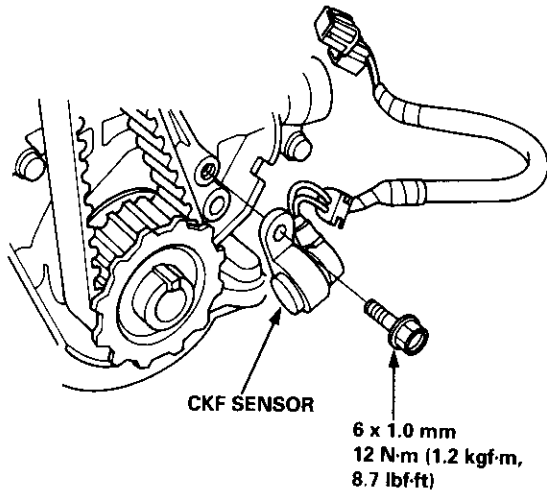

10. Loosen the adjusting bolt 180°. Push the tensioner to remove tension from the timing belt, then retighten the adjusting bolt.

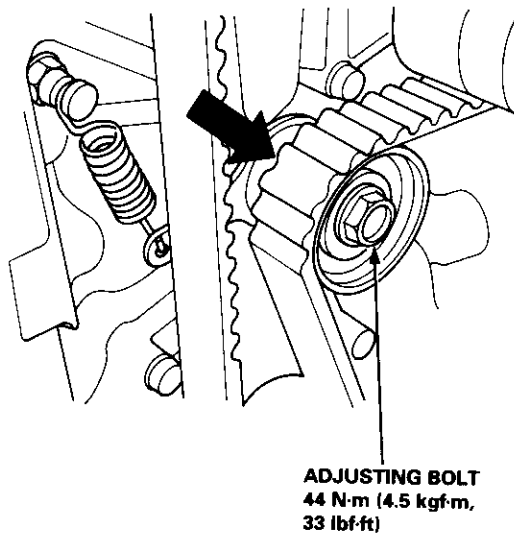

11. Remove the timing belt.

Installation

Install the timing belt in the reverse order of removal; Only key points are described here.

1. Set the timing belt drive pulley so that the No. 1 piston is at top dead center (TDC). Align the groove on the timing belt drive pulley to the pointer on the oil pump.

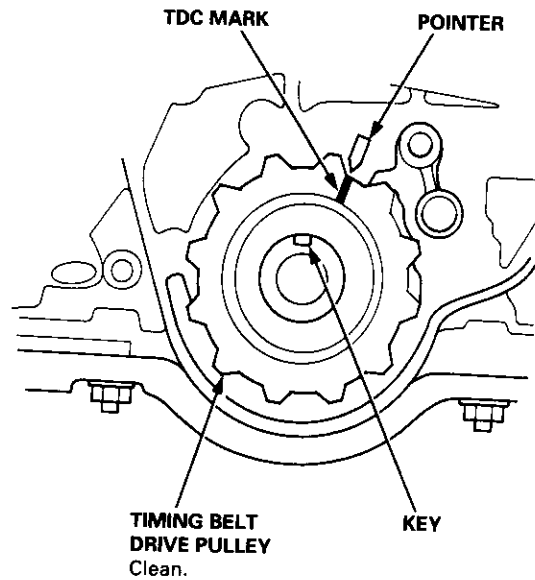

2. Set the camshaft pulley to TDC. Align the TDC marks on the camshaft pulley to the cylinder head surface.

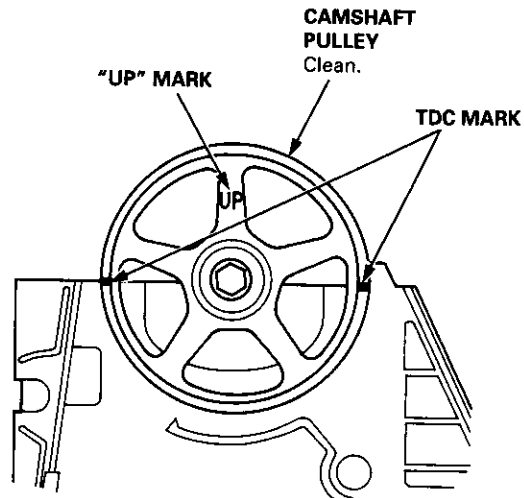



3. Install the timing belt tightly in the sequence shown.
 ①Timing belt drive pulley (crankshaft) →②Adjusting pulley →③Water pump pulley →④Camshaft pulley.

NOTE: Make sure the timing belt drive pulley and camshaft pulley are at TDC.

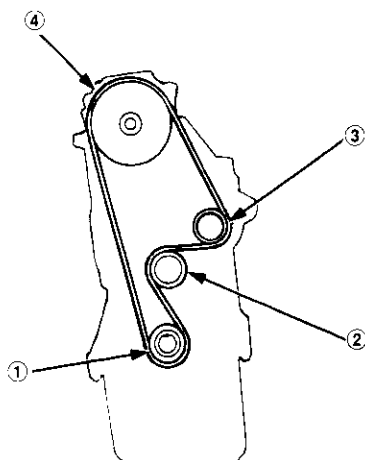

4. Loosen and retighten the adjusting bolt to tension the timing belt.
 5. Install the lower cover and upper cover.

NOTE: Clean the upper and lower covers before installation.

6. Install the crankshaft pulley, then tighten the pulley bolt (see page 6-16).
 7. Rotate the crankshaft pulley about five or six turns counterclockwise so that the timing belt positions on the pulleys.
 8. Adjust the timing belt tension (see page 6-18).

9. Check that the crankshaft pulley and camshaft pulley are both at TDC.

CRANKSHAFT PULLEY:

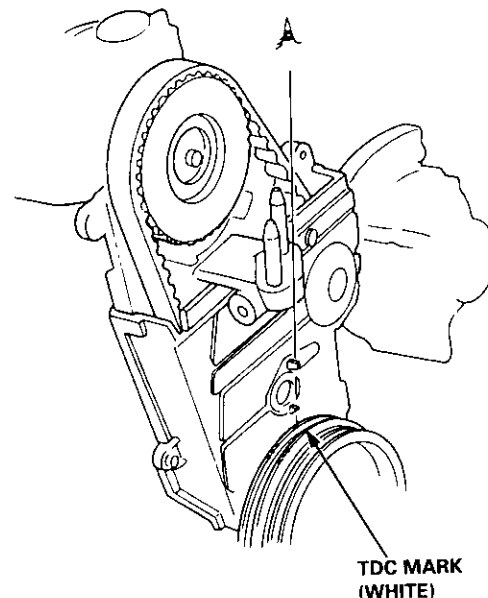

CAMSHAFT PULLEY:

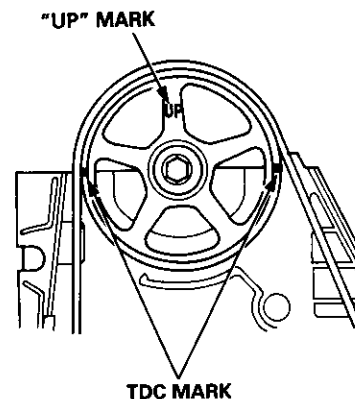

10. If the camshaft and crankshaft pulleys are not positioned at TDC, remove the timing belt and adjust the position following the procedure on page 6-20. Then reinstall the timing belt.
11. After installation, adjust the tension of each belt.
- See section 23 for alternator belt tension adjustment.
 - See section 22 for A/C compressor belt tension adjustment.
 - See section 17 for P/S pump belt tension adjustment.

Crankshaft Speed Fluctuation (CKF) Sensor

Replacement

1. Remove the cylinder head cover.

NOTE: Refer to page 6-46 when installing.
2. Remove the crankshaft pulley (see page 6-16).
3. Remove the upper cover and dipstick/tube (see page 6-19).
4. Remove the lower cover and idler pulley bracket (see page 6-19).
5. Disconnect the CKF sensor connector, then remove the CKF sensor.

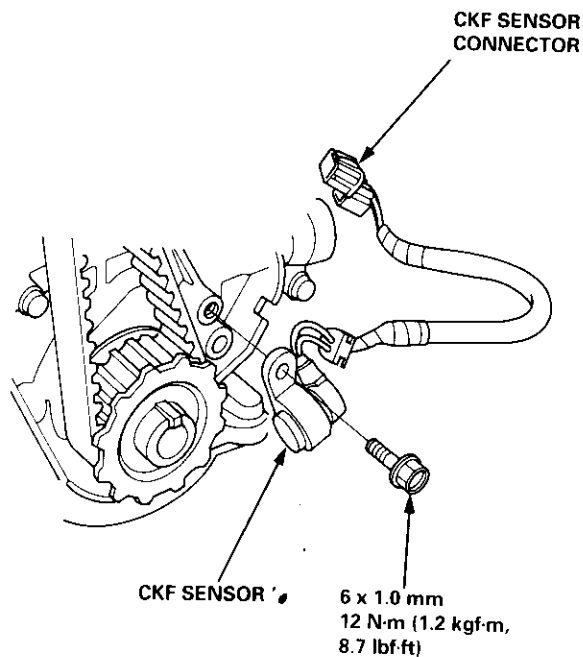

6. Install the CKF sensor in reverse order of removal.



Cylinder Head

Illustrated Index

CAUTION:

- To avoid damage, wait until the engine coolant temperature drops below 100°F (38°C) before removing the cylinder head.
- When handling a metal gasket, take care not to fold it or damage the contact surface.

NOTE: Use new O-rings and gaskets when reassembling.

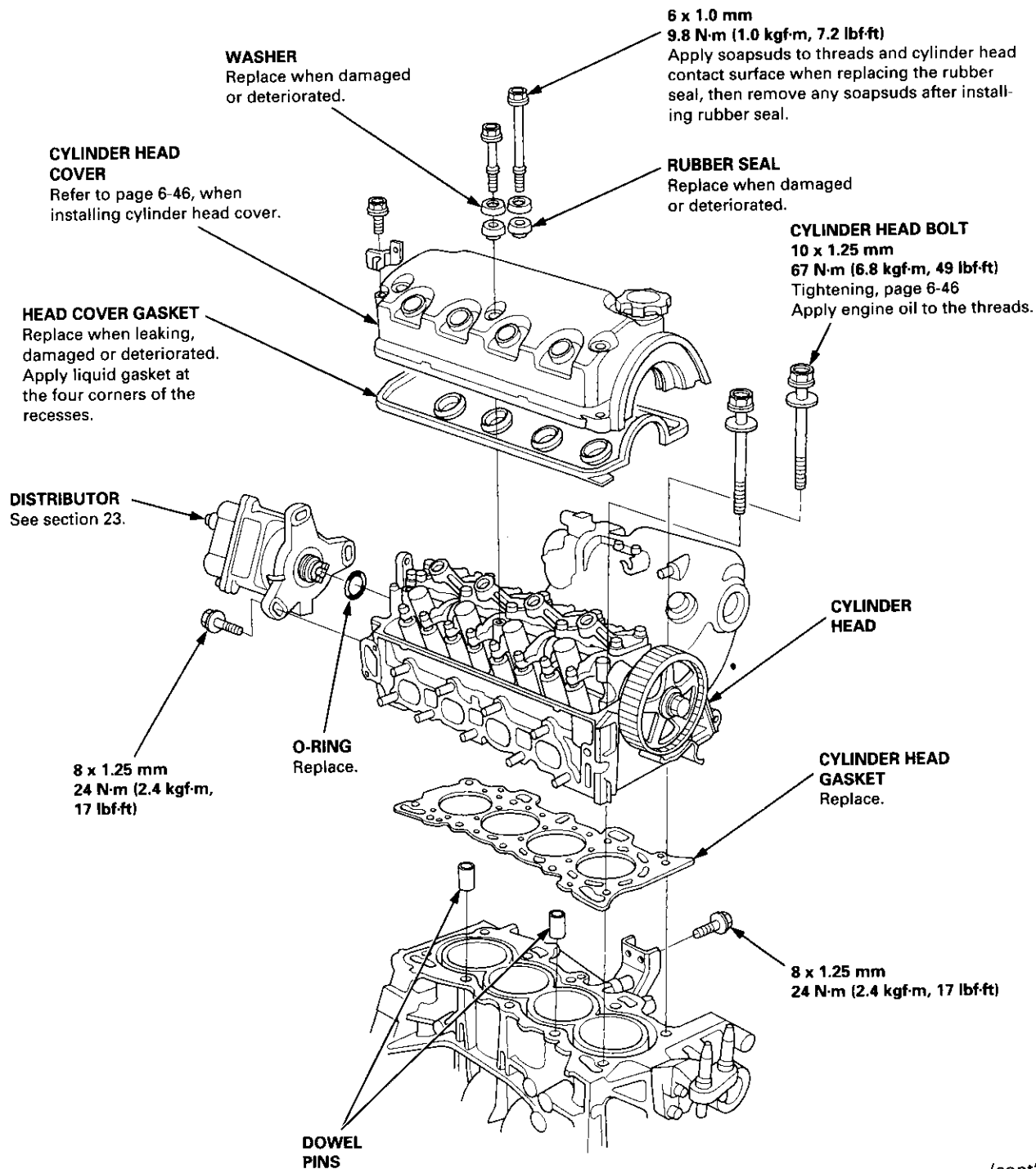

(cont'd)

Cylinder Head

Illustrated Index (cont'd)



Prior to reassembling, clean all the parts in solvent, dry them and apply lubricant to any contact parts.

D16Y7 engine:

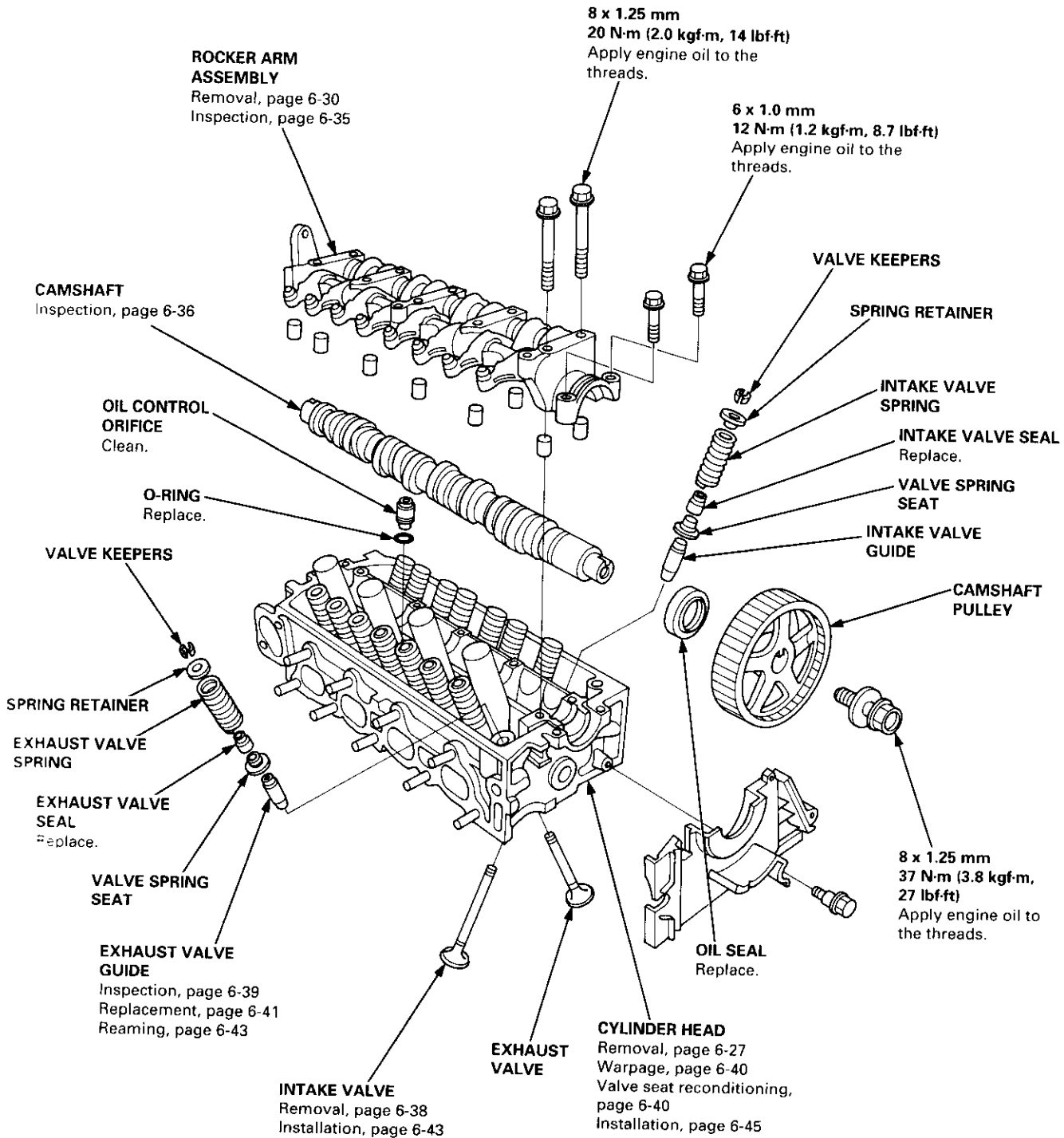



D16Y5 engine:

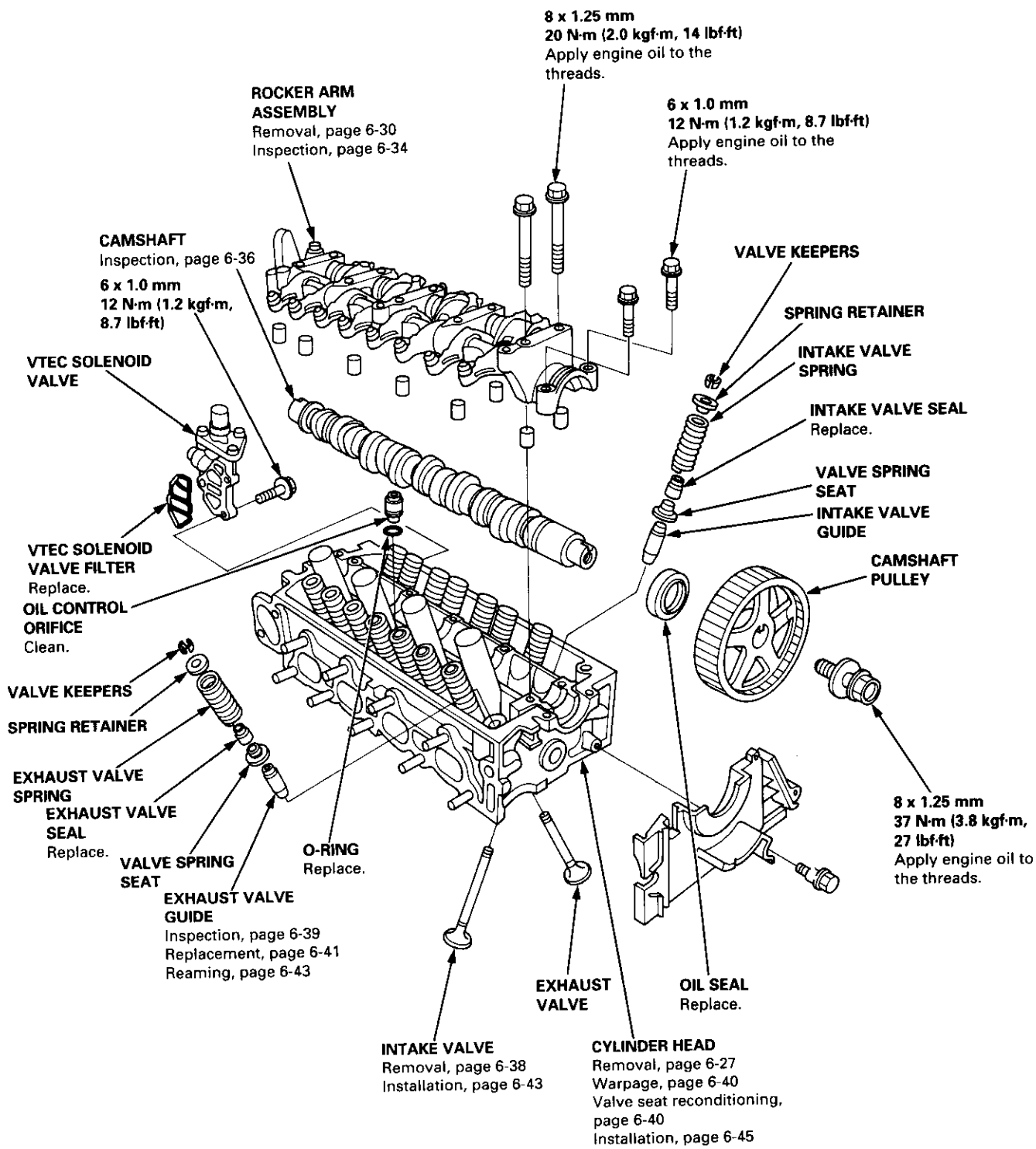

(cont'd)

Cylinder Head

Illustrated Index (cont'd)



Prior to reassembling, clean all the parts in solvent, dry them and apply lubricant to any contact parts.

D16Y8 engine:

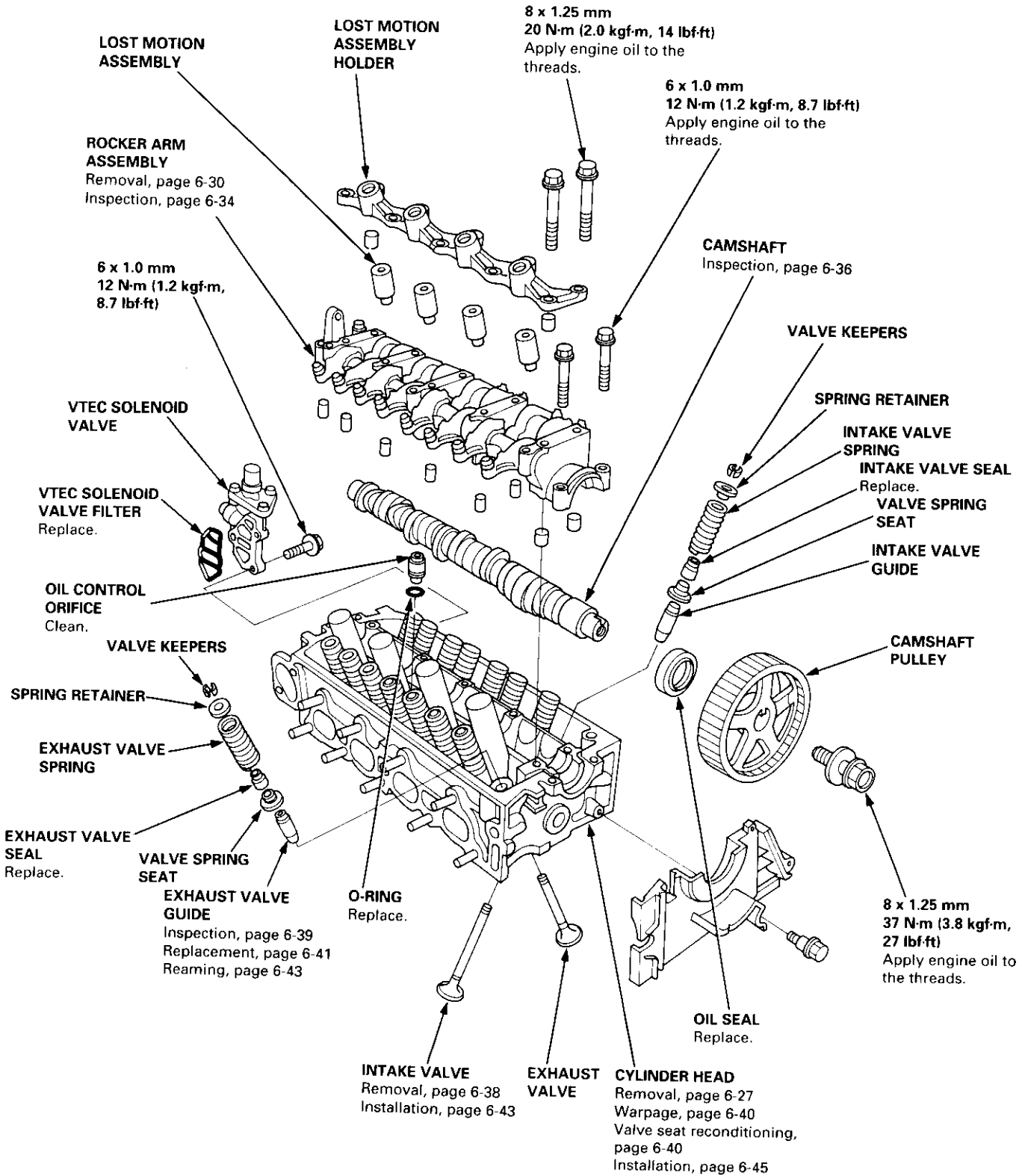



Removal

Engine removal is not required for this procedure.

⚠ WARNING Make sure jacks and safety stands are placed properly and hoist brackets are attached to the correct positions on the engine.

CAUTION:

- Use fender covers to avoid damaging painted surfaces.
- To avoid damage, unplug the wiring connectors carefully while holding the connector portion to avoid damage.
- To avoid damaging the cylinder head, wait until the engine coolant temperature drops below 100°F (38°C) before loosening the retaining bolts.

NOTE:

- Mark all wiring and hoses to avoid misconnection. Also, be sure that they do not contact other wiring or hoses, or interfere with other parts.
- Inspect the timing belt before removing the cylinder head.
- Turn the crankshaft pulley so that the No. 1 piston is at top dead center (see page 6-21).

1. Disconnect the negative terminal from the battery.
2. Drain the engine coolant (see page 10-7).
 - Remove the radiator cap to speed draining.
3. Remove the intake air duct and air cleaner housing (see page 5-3).
4. Remove the mounting bolt and lock bolt, then remove the power steering (P/S) pump belt and pump (see page 5-5).
5. Loosen the idler pulley center nut and adjusting bolt, then remove the air conditioning (A/C) compressor belt (see page 5-6).
6. Loosen the mounting nut and lock bolt, then remove the alternator belt (see page 6-19).
7. Remove the P/S pump bracket (see page 5-12).

8. Remove the throttle cable by loosening the locknut, then slip the cable end out of the throttle linkage.

NOTE:

- Take care not to bend the cable when removing it. Always replace any kinked cable with a new one.
- Adjust the throttle cable when installing (see section 11).

D16Y7 engine:

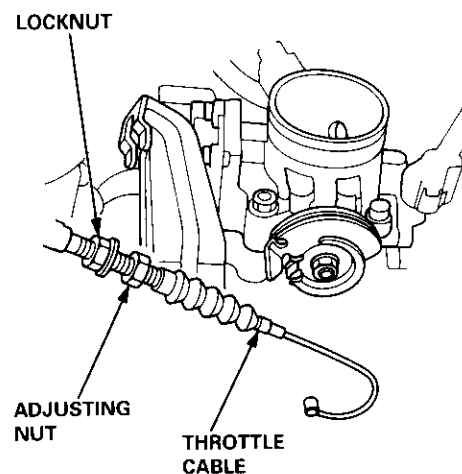

D16Y5, D16Y8 engines:

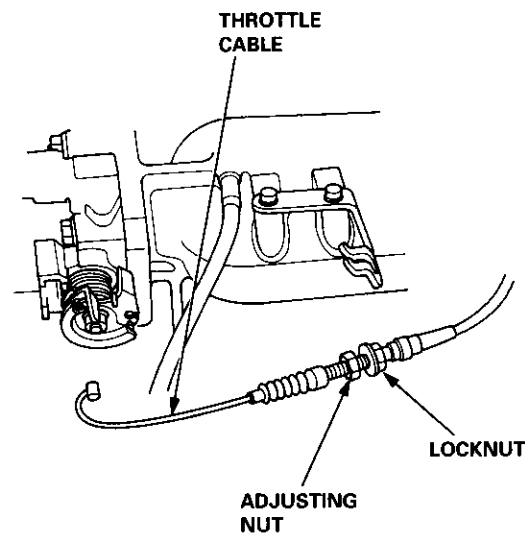

(cont'd)

Cylinder Head

Removal (cont'd)

9. Relieve fuel pressure (see section 11).

⚠ WARNING Do not smoke while working on the fuel system. Keep open flame or spark away from the work area. Drain fuel only into an approved container.

10. Remove the evaporative emission (EVAP) control canister hose, fuel feed hose and breather hose.

D16Y7 engine:

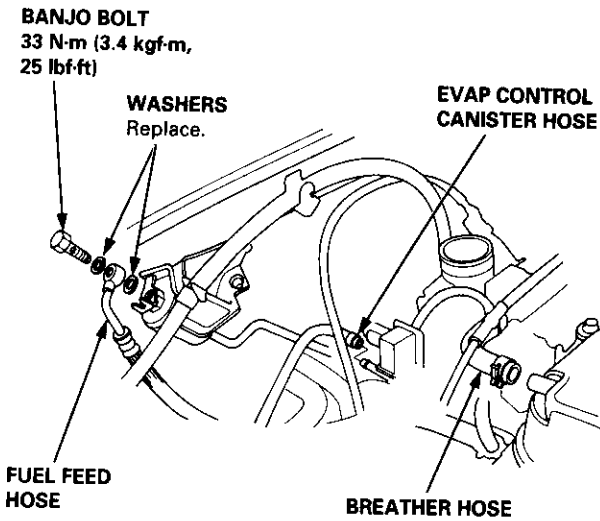

D16Y5, D16Y8 engines:

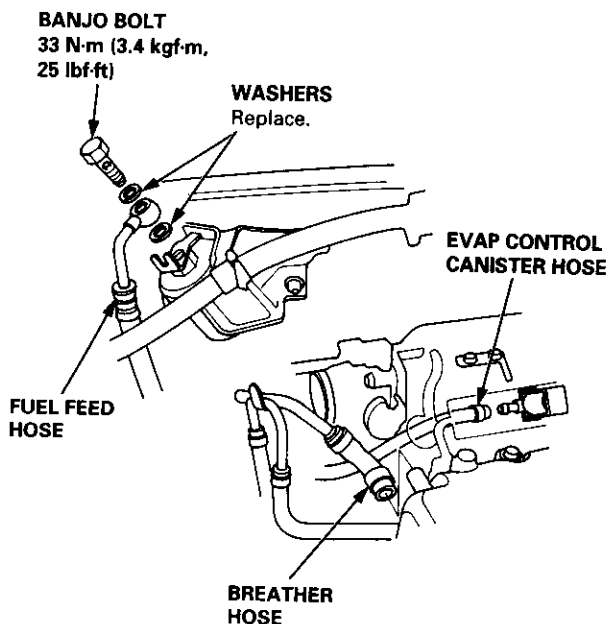

11. Remove the brake booster vacuum hose, fuel return hose and vacuum hose (see page 5-4).

12. Remove the water bypass hose and positive crankcase ventilation (PCV) hose.

D16Y7 engine:

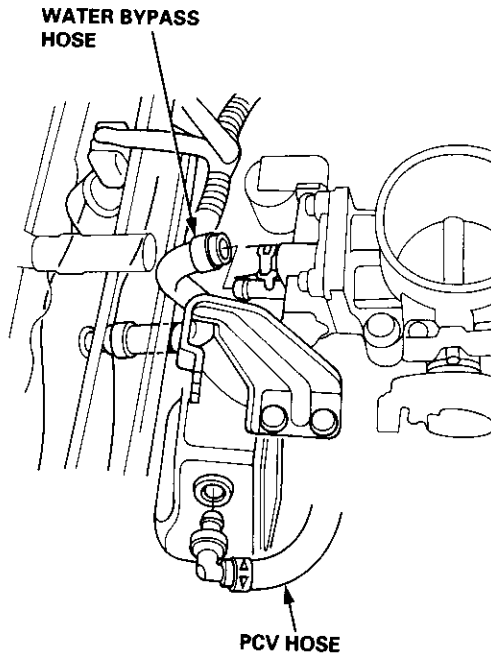

D16Y5, D16Y8 engines:

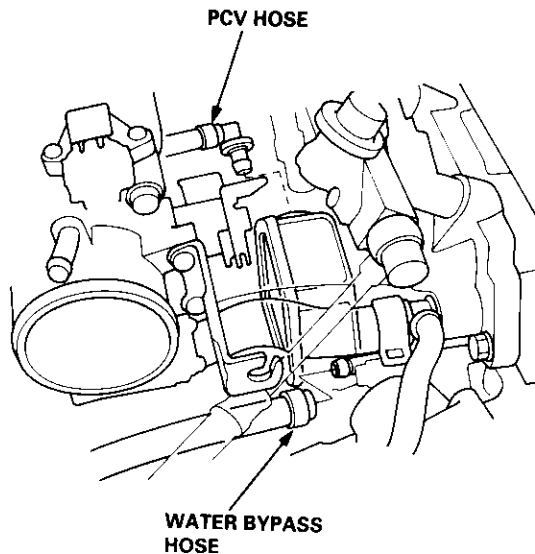



13. Remove the upper radiator hose, heater hose and water bypass hose.

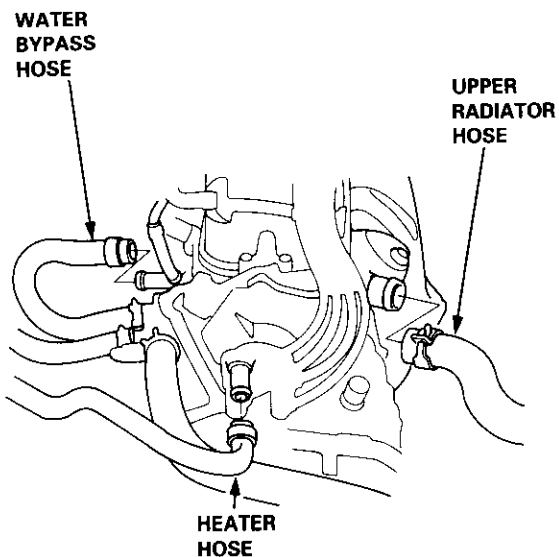

14. Remove the engine wire harness connectors and wire harness clamps from the cylinder head and the intake manifold.

- Four fuel injector connectors
- Engine coolant temperature (ECT) sensor connector
- ECT switch connector
- ECT gauge sending unit connector
- Throttle position sensor connector
- Manifold absolute pressure (MAP) sensor connector
- Primary heated oxygen sensor (primary HO2S) connector
- Secondary heated oxygen sensor (secondary HO2S) connector (D16Y7 engine)
- Exhaust gas recirculation (EGR) valve lift sensor connector (D16Y5 engine)
- VTEC solenoid valve connector (D16Y5, D16Y8 engines)
- VTEC pressure switch connector (D16Y5, D16Y8 engines)
- Idle air control (IAC) valve connector

15. Remove the spark plug caps and distributor from the cylinder head.

16. Remove the upper bracket.

NOTE:

- Use a jack to support the engine before the upper bracket is removed.
- Make sure to place a cushion between the oil pan and the jack.

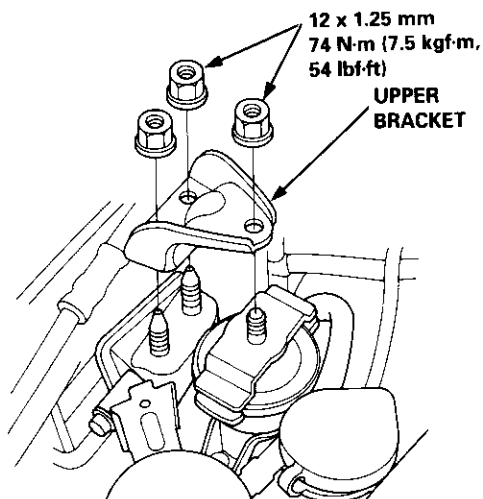

17. Remove the cylinder head cover.

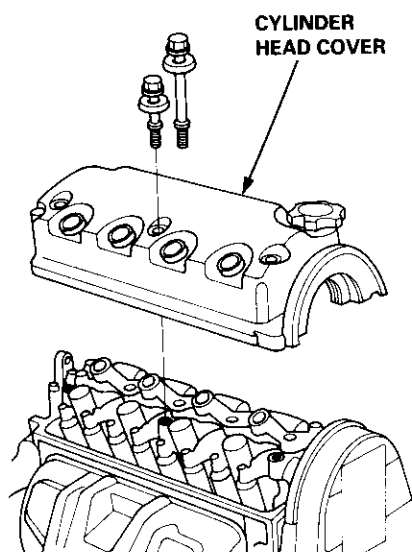

(cont'd)

Cylinder Head

Rocker Arms

Removal (cont'd)

18. Remove the timing belt (see page 6-19).
19. Remove the camshaft pulley and back cover.

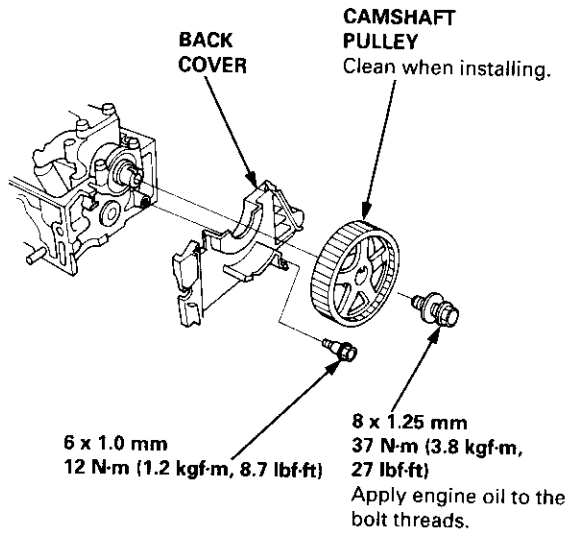

20. Remove the exhaust manifold (see pages 9-6 and 9-7).
21. Remove the intake manifold (see pages 9-2 thru 4).
22. Remove the cylinder head bolts, then remove the cylinder head.

CAUTION: To prevent warpage, unscrew the bolts in sequence 1/3 turn at a time; repeat the sequence until all bolts are loosened.

CYLINDER HEAD BOLTS LOOSENING SEQUENCE:

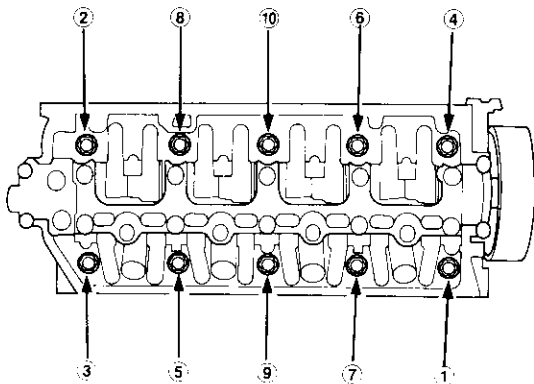

Removal

1. Loosen the adjusting screws.

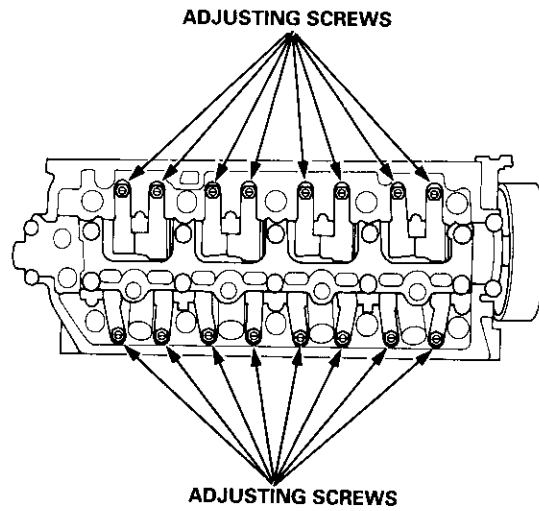

2. Unscrew the camshaft holder bolts, then remove the rocker arm assembly.

NOTE:

- Unscrew the camshaft holder bolts two turns at a time, in a crisscross pattern, to prevent damaging the valves or rocker arm assembly.
- When removing the rocker arm assembly, do not remove the camshaft holder bolts. The bolts will keep the camshaft holders, the springs and the rocker arms on the shaft.

CAMSHAFT HOLDER BOLTS LOOSENING SEQUENCE:

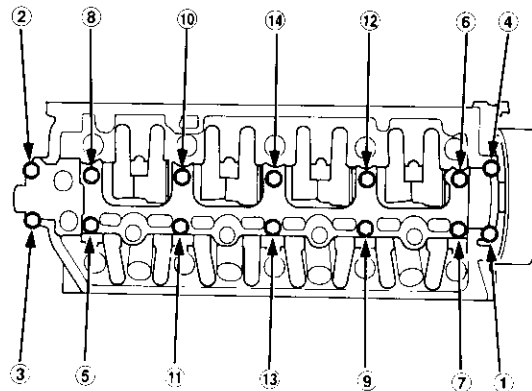



Disassembly/Reassembly

NOTE:

- Identify parts as they are removed to ensure reinstallation in original locations.
- Inspect rocker shafts and rocker arms (see page 6-35).
- Rocker arms must be installed in the same position if reused.
- When removing or installing the rocker arm assembly, do not remove the camshaft holder bolts. The bolts will keep the holders, springs and rocker arms on the shaft.



Prior to reassembling, clean all the parts in solvent, dry them and apply lubricant to any contact points.

D16Y7 engine:

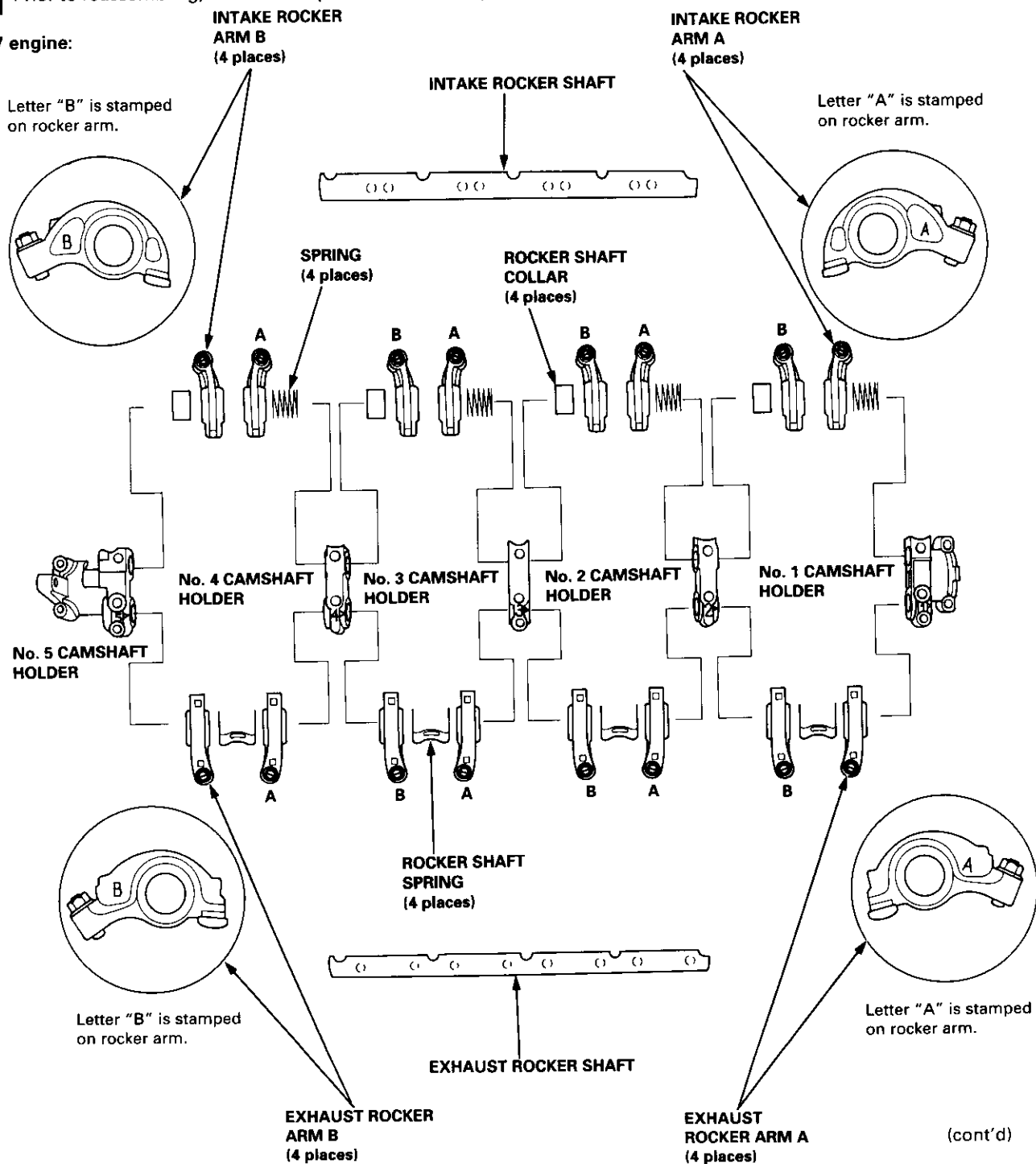

(cont'd)

Rocker Arms

Disassembly/Reassembly (cont'd)

NOTE:

- Identify parts as they are removed to ensure reinstallation in original locations.
- Inspect rocker shafts and rocker arms (see page 6-34).
- Rocker arms must be installed in the same position if reused.
- When removing or installing the rocker arm assembly, do not remove the camshaft holder bolts. The bolts will keep the holders, springs and rocker arms on the shaft.

 Prior to reassembling, clean all the parts in solvent, dry them and apply lubricant to any contact points.

D16Y5 engine:

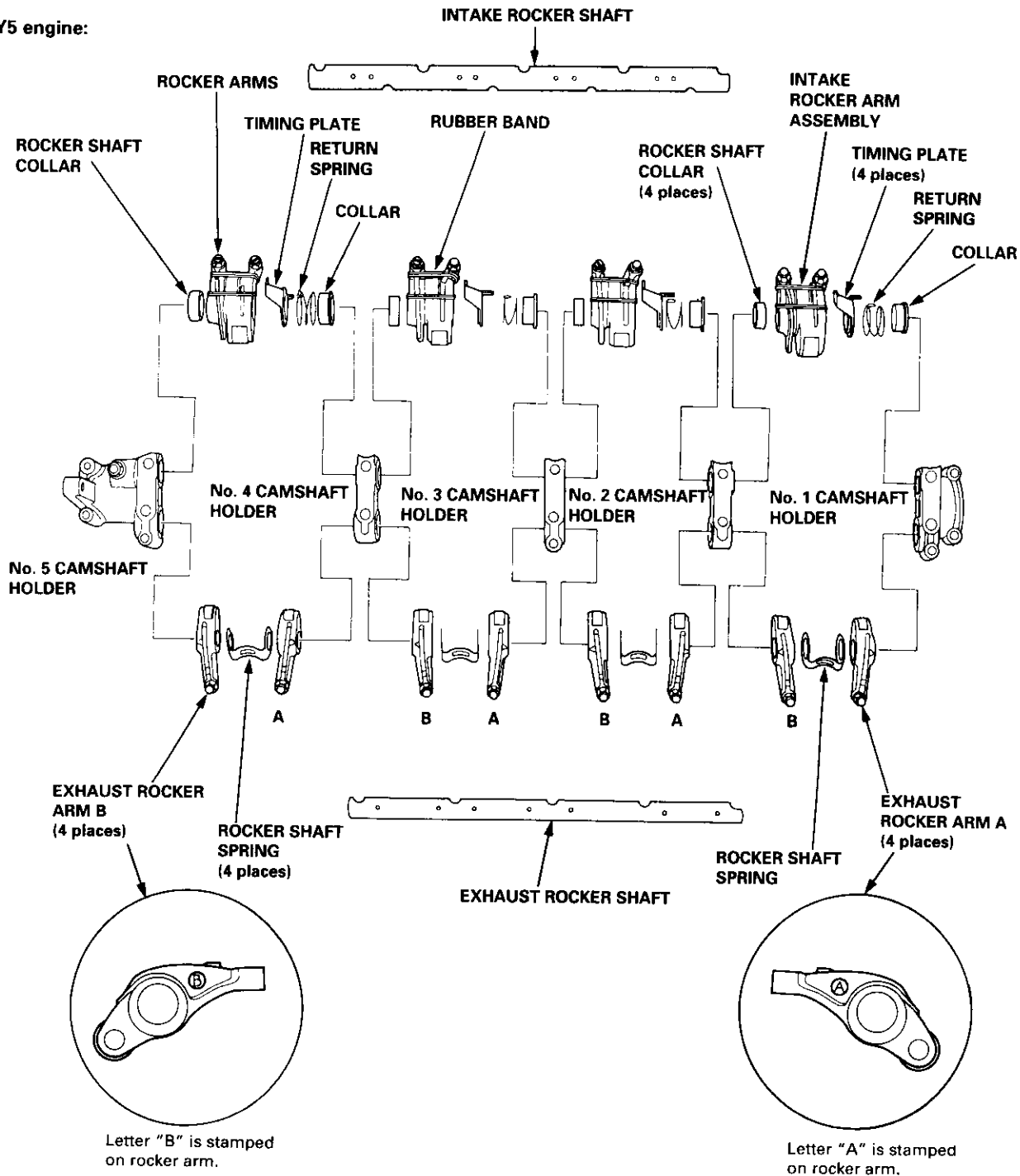



D16Y8 engine:

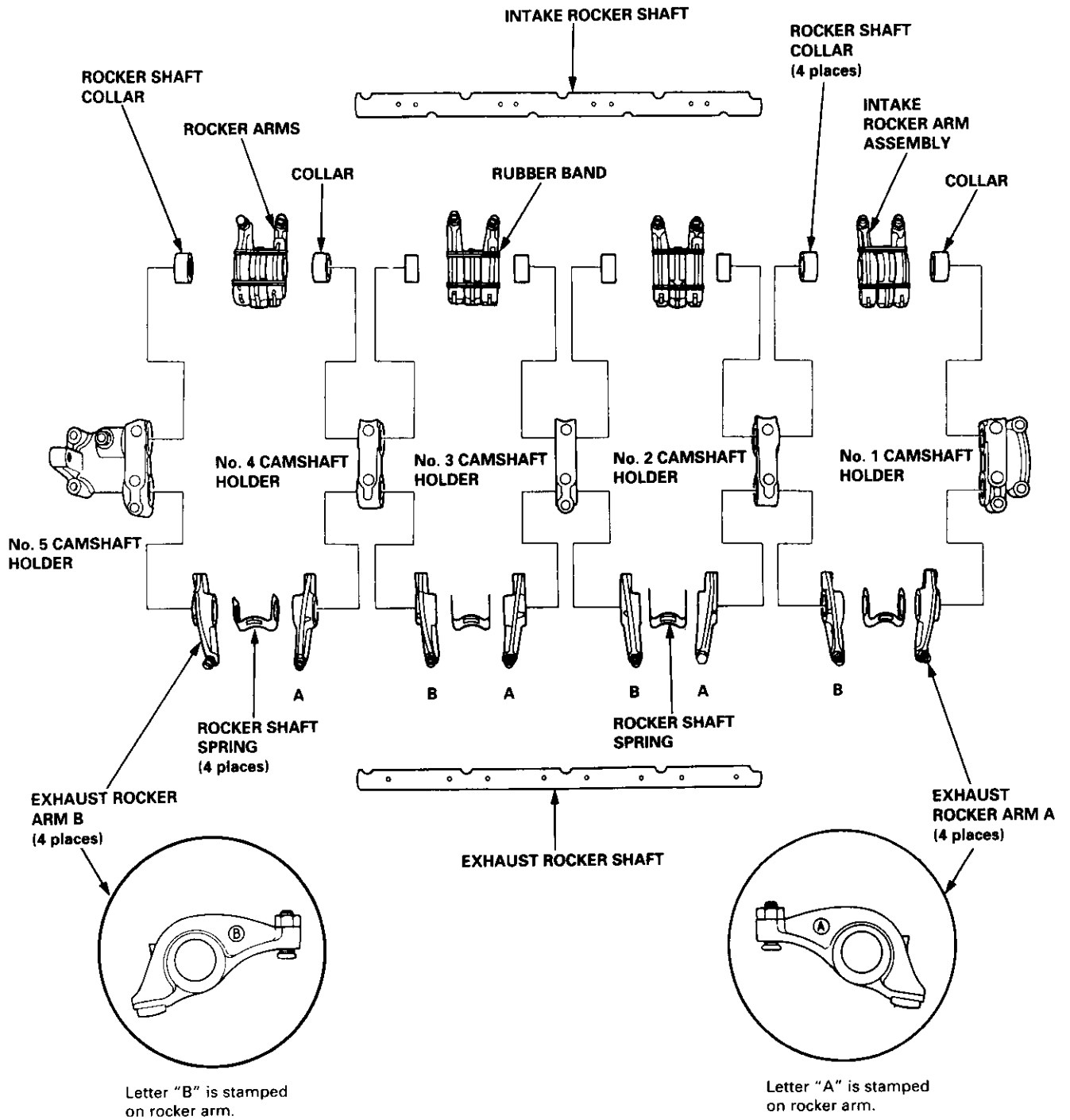

Rocker Arms and Lost Motion Assemblies

Inspection (D16Y5, D16Y8 engines)

NOTE: When reassembling the primary rocker arm, carefully apply air pressure to the oil passage of the rocker arm.

1. Inspect the rocker arm piston. Push it manually.
— If it does not move smoothly, replace the rocker arm assembly.

D16Y5 engine:

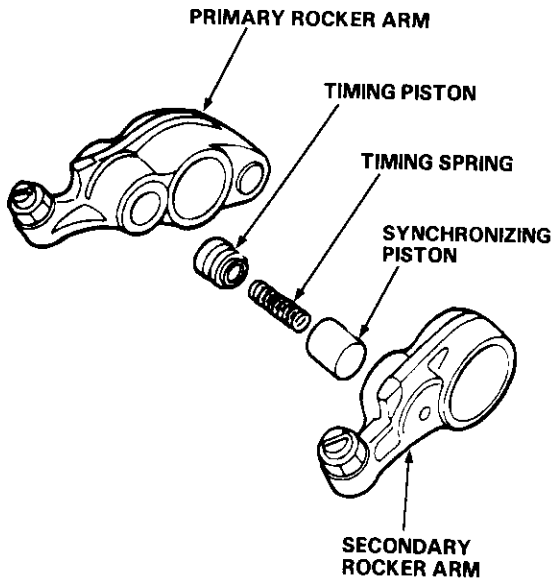

D16Y8 engine:

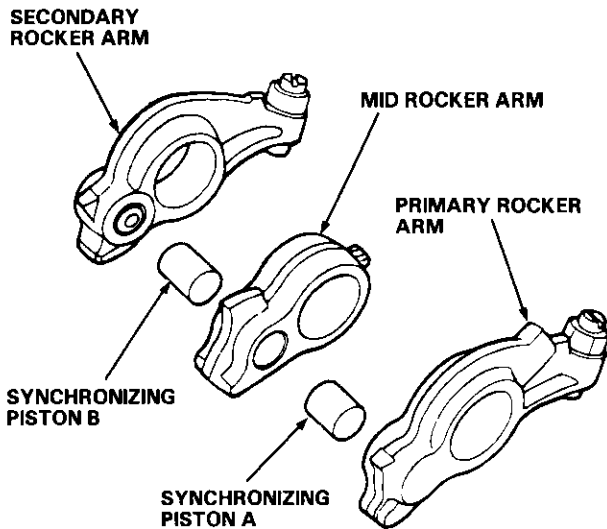

NOTE:

- Apply oil to the pistons when reassembling.
- Bundle the rocker arms with a rubber band to prevent them from separating.

D16Y5 engine:

NOTE: Set the timing plate and return spring as shown below.

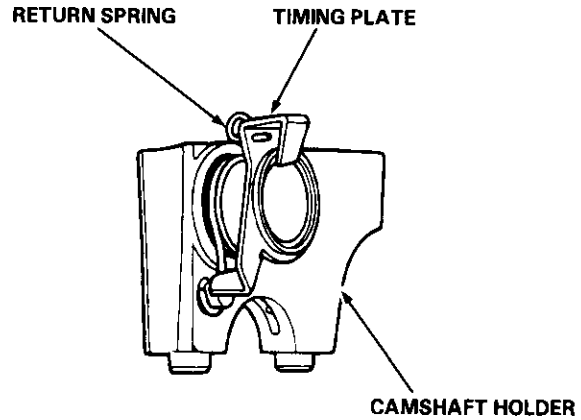

D16Y8 engine:

2. Remove the lost motion assembly from the holder and inspect it. Test it by pushing the plunger with your finger.
— If the lost motion assembly plunger does not move smoothly, replace it.

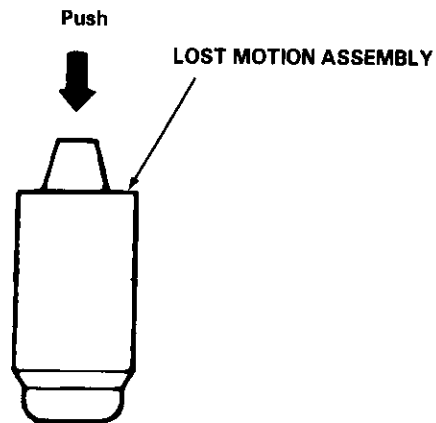



Clearance Inspection

Measure both the intake rocker shaft and exhaust rocker shaft.

1. Measure the diameter of the shaft at the first rocker location.

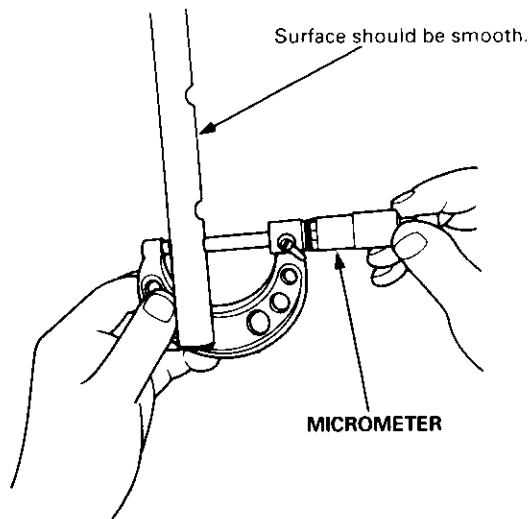

2. Zero the gauge to the shaft diameter.

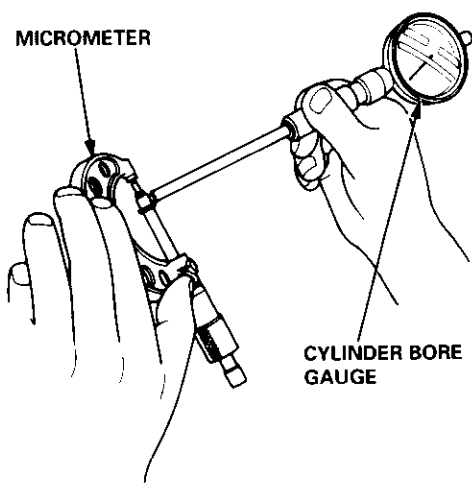

3. Measure the inside diameter of the rocker arm and check for an out-of-round condition.

Rocker Arm-to-Shaft Clearance:

Standard (New):

Intake: 0.017 – 0.050 mm
(0.0007 – 0.0020 in)

Exhaust: 0.018 – 0.054 mm
(0.0007 – 0.0021 in)

Service Limit: 0.08 mm (0.003 in)

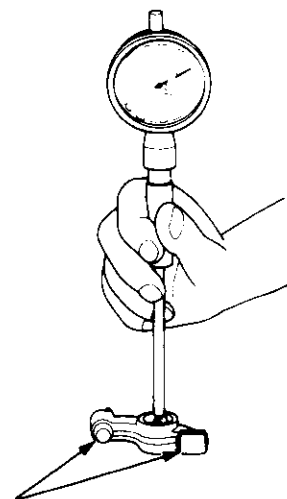

4. Repeat these measurements on all the rockers.
— If the clearance is over the service limit, replace the rocker shaft and all over-tolerance rocker arms.

Camshaft

Inspection

NOTE:

- Do not rotate the camshaft during inspection.
- Remove the rocker arms and rocker shafts.

1. Put the camshaft and the camshaft holders on the cylinder head, then tighten the bolts to the specified torque.

Specified torque:

8 mm bolts: 20 N·m (2.0 kgf·m 14 lbf·ft)

Apply engine oil to the threads.

6 mm bolts: 12 N·m (1.2 kgf·m 8.7 lbf·ft)

Apply engine oil to the threads.

6 mm bolts: ⑪, ⑫, ⑬, ⑭

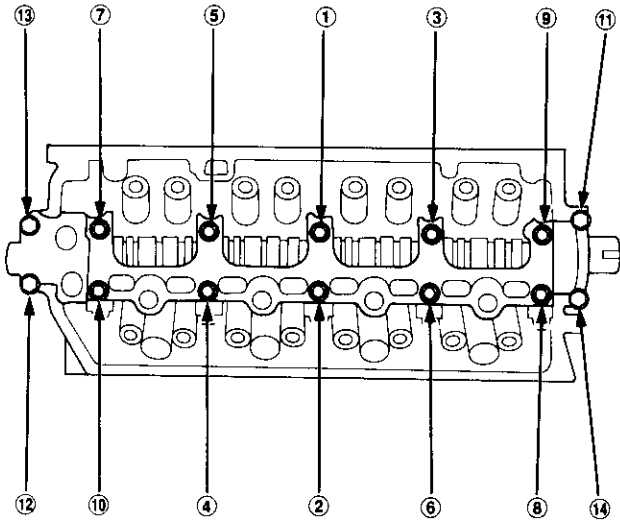

2. Seat the camshaft by pushing it toward the rear of the cylinder head.
3. Zero the dial indicator against the end of the camshaft. Push the camshaft back and forth, and read the end play.

Camshaft End Play:

Standard (New): 0.05 – 0.15 mm
(0.002 – 0.006 in)

Service Limit: 0.5 mm (0.02 in)

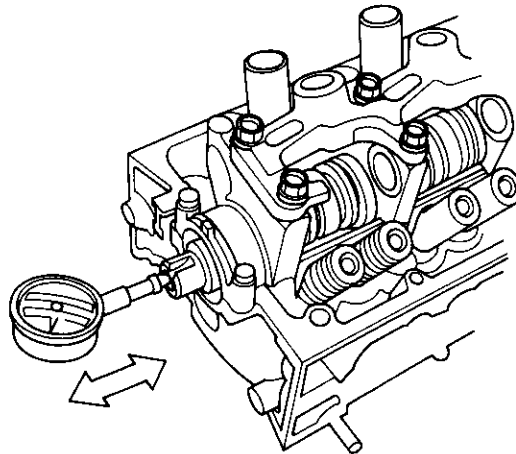

4. Remove the bolts, then remove the camshaft holders from the cylinder head.
 - Lift the camshaft out of the cylinder head, wipe it clean, then inspect the lift ramps. Replace the camshaft if any lobes are pitted, scored, or excessively worn.
 - Clean the camshaft bearing surfaces in the cylinder head, then set the camshaft back in place.
 - Place a plastigage strip across each journal.
5. Install the camshaft holders, and tighten the bolts to the specified torque.



6. Remove the camshaft holders, then measure the widest portion of the plastigage on each journal.

Camshaft-to-Holder Oil Clearance:

Standard (New): 0.050 – 0.089 mm
(0.002 – 0.004 in)

Service Limit : 0.15 mm (0.006 in)

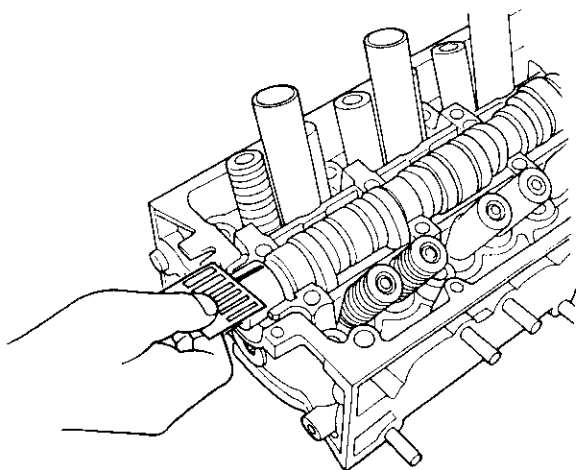

7. If the camshaft-to-holder oil clearance is out of tolerance:
- And the camshaft has already been replaced, you must replace the cylinder head.
 - If the camshaft has not been replaced, first check the total runout with the camshaft supported on V-blocks.

Camshaft Total Runout:

Standard (New): 0.03 mm (0.001 in) max.

Service Limit: 0.04 mm (0.002 in)

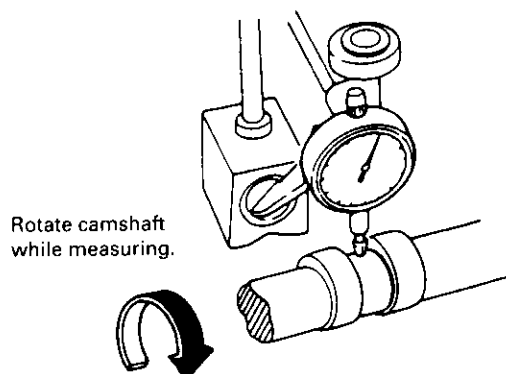

- If the total runout of the camshaft is within tolerance, replace the cylinder head.
- If the total runout is out of tolerance, replace the camshaft and recheck the camshaft-to-holder oil clearance. If the oil clearance is still out of tolerance, replace the cylinder head.

8. Check the cam lobe height wear.

Cam lobe height standard (New)

Unit mm (in)

		INTAKE	EXHAUST
D16Y7 engine		35.299 (1.3897)	37.281 (1.4678)
D16Y5 engine	PRI	38.427 (1.5129)	38.784 (1.5269)
	SEC	32.193 (1.2674)	
D16Y8 engine	PRI	36.778 (1.4479)	38.008 (1.4964)
	MID	38.274 (1.5068)	
	SEC	37.065 (1.4592)	

PRI: Primary cam lobe, SEC: Secondary cam lobe
MID: Mid cam lobe, T/B: Timing belt
IN: Intake, EX: Exhaust

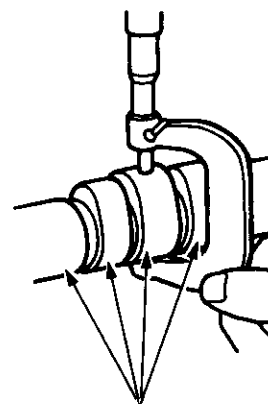
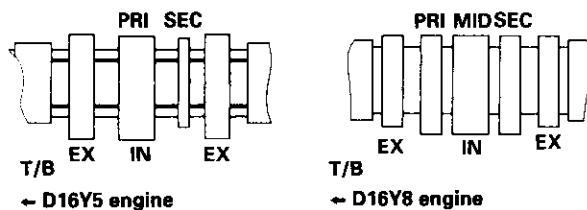

Check this area for wear.

Valves, Valve Springs and Valve Seals

Removal

NOTE: Identify valves and valve springs as they are removed so that each item can be reinstalled in its original position.

1. Using an appropriate-sized socket and plastic mallet, lightly tap the valve retainer to loosen the valve keepers before installing the valve spring compressor.

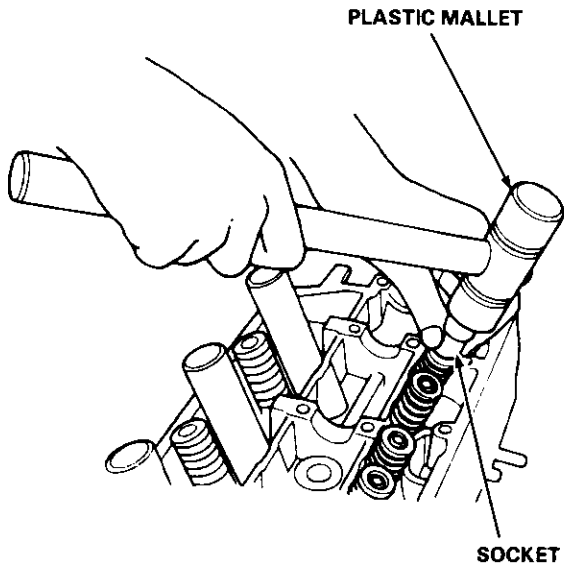

2. Install the spring compressor. Compress the spring and remove the valve keeper.

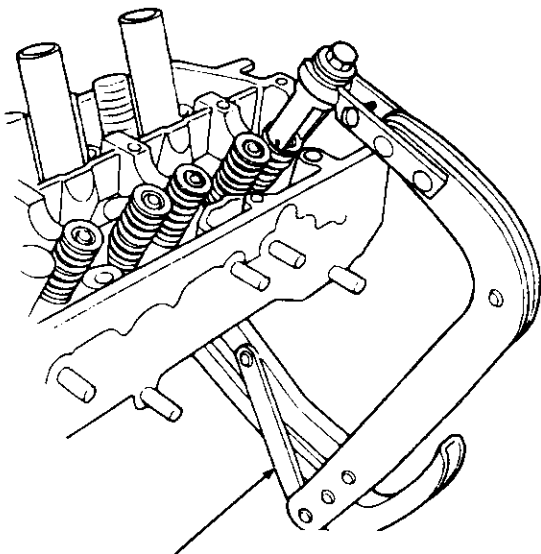

VALVE SPRING COMPRESSOR
Snap-on CF711 or KD-383
with #32 JAWS

3. Install the valve guide seal remover.

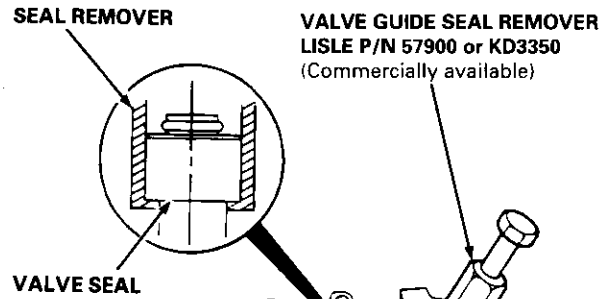

VALVE GUIDE SEAL REMOVER
LISLE P/N 57900 or KD3350
(Commercially available)

4. Remove the valve seal.

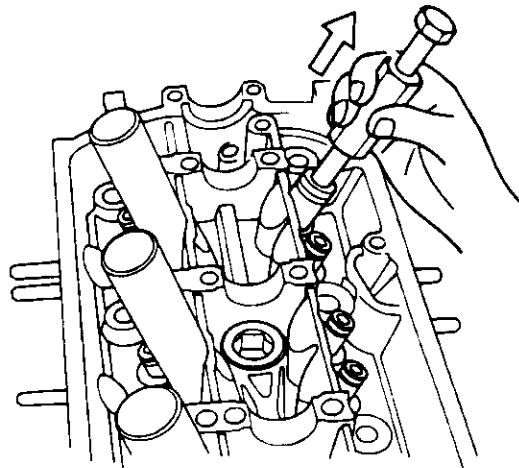



Valve Movement

Measure the guide-to-stem clearance with a dial indicator while rocking the stem in the direction of normal thrust (wobble method).

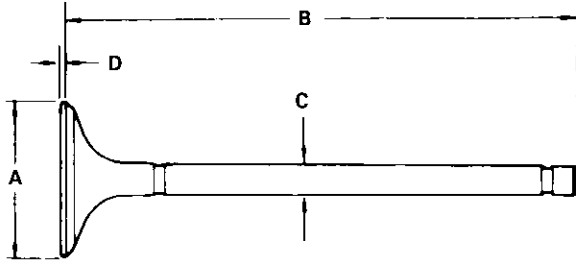

Intake Valve Dimensions

- A Standard (New): 29.9 – 30.1 mm
(1.18 – 1.19 in)
- B Standard (New): 117.42 – 117.72 mm
(4.623 – 4.635 in)
- C Standard (New): 5.48 – 5.49 mm
(0.2157 – 0.2161 in)
- C Service Limit: 5.45 mm (0.2146 in)
- D Standard (New): 0.85 – 1.15 mm
(0.033 – 0.045 in)
- D Service Limit: 0.65 mm (0.026 in)

Exhaust Valve Dimensions

- A Standard (New): 25.9 – 26.1 mm
(1.02 – 1.03 in)
- B Standard (New): 114.60 – 114.90 mm
(4.512 – 4.524 in)
- C Standard (New): 5.45 – 5.46 mm
(0.2146 – 0.2150 in)
- C Service Limit: 5.42 mm (0.2134 in)
- D Standard (New): 1.05 – 1.35 mm
(0.041 – 0.053 in)
- D Service Limit: 0.95 mm (0.037 in)

Intake Valve Stem-to-Guide Clearance:

- Standard (New): 0.04 – 0.10 mm
(0.002 – 0.004 in)
- Service Limit: 0.16 mm (0.006 in)

Exhaust Valve Stem-to-Guide Clearance:

- Standard (New): 0.10 – 0.16 mm
(0.004 – 0.006 in)
- Service Limit: 0.22 mm (0.009 in)

Valve extended 10 mm out from seat.

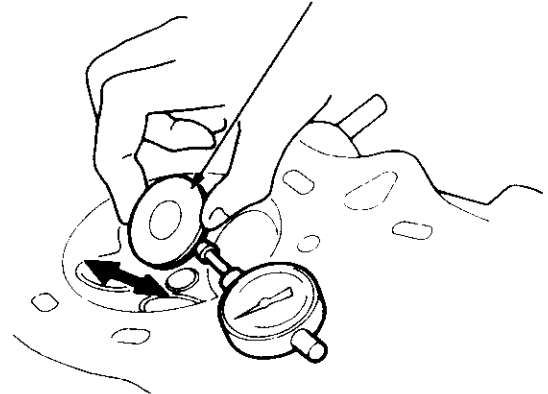

- If the measurement exceeds the service limit, recheck using a new valve.
- If the measurement is now within the service limit, reassemble using a new valve.
- If the measurement still exceeds the limit, recheck using the alternate method below, then replace the valve and guide, if necessary.

NOTE: An alternate method of checking guide to stem clearance is to subtract the O.D. of the valve stem, measured with a micrometer, from the I.D. of the valve guide, measured with an inside micrometer or ball gauge. Take the measurements in three places along the valve stem and three places inside the valve guide. The difference between the largest guide measurement and the smallest stem measurement should not exceed the service limit.

Intake Valve Stem-to-Guide Clearance:

- Standard (New): 0.02 – 0.05 mm
(0.001 – 0.002 in)
- Service Limit: 0.08 mm (0.003 in)

Exhaust Valve Stem-to-Guide Clearance:

- Standard (New): 0.05 – 0.08 mm
(0.002 – 0.003 in)
- Service Limit: 0.11 mm (0.004 in)

Warpage

NOTE: If the camshaft-to-holder oil clearances (see page 6-36) are not within specification, the cylinder head cannot be resurfaced.

If the camshaft-to-holder oil clearances are within specifications, check the cylinder head for warpage.

- If warpage is less than 0.05 mm (0.002 in), cylinder head resurfacing is not required.
- If warpage is between 0.05 mm (0.002 in) and 0.2 mm (0.008 in), resurface the cylinder head.
- Maximum resurface limit is 0.2 mm (0.008 in) based on a height of 93 mm (3.66 in).

PRECISION STRAIGHT EDGE

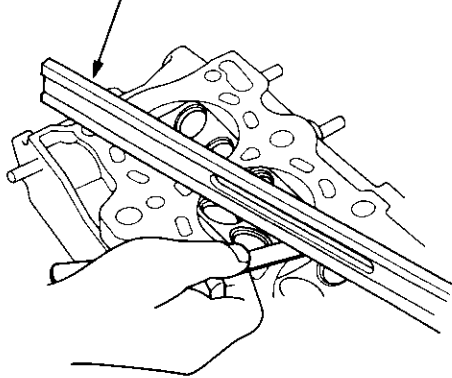

Measure along edges, and three ways across center.

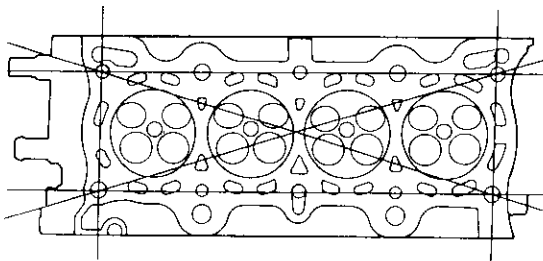

Cylinder Head Height:

Standard (New): 92.95 – 93.05 mm
(3.659 – 3.663 in)

Reconditioning

1. Renew the valve seats in the cylinder head using a valve seat cutter.

NOTE: If the guides are worn (see page 6-39), replace them (see page 6-41) before cutting the valve seats.

VALVE SEAT CUTTER

(Commercially available)

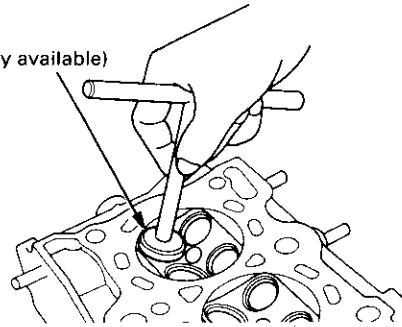

2. Carefully cut a 45° seat, removing only enough material to ensure a smooth and concentric seat.
3. Bevel the upper edge of the seat with the 30° cutter and the lower edge of the seat with the 60° cutter. Check the width of the seat and adjust accordingly.
4. Make one more very light pass with the 45° cutter to remove any possible burrs caused by the other cutters.

Valve Seat Width:

Standard (New):

Intake: 0.85 – 1.15 mm (0.033 – 0.045 in)

Exhaust: 1.25 – 1.55 mm (0.049 – 0.061 in)

Service Limit:

Intake: 1.6 mm (0.063 in)

Exhaust: 2.0 mm (0.079 in)

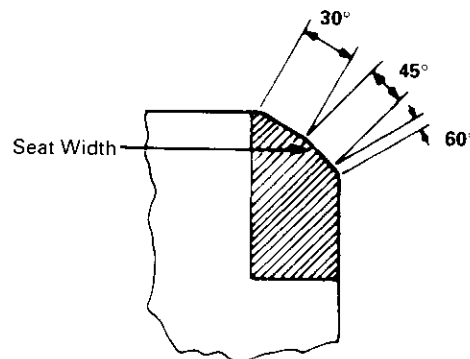

5. After resurfacing the seat, inspect for even valve seating: Apply Prussian Blue compound to the valve face, and insert the valve in its original location in the head, then lift and snap it closed against the seat several times.

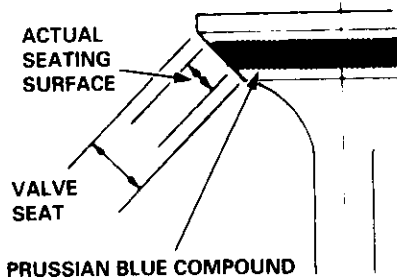

6. The actual valve seating surface, as shown by the blue compound, should be centered on the seat.
 - If it is too high (closer to the valve stem), you must make a second cut with the 60° cutter to move it down, then one more cut with the 45° cutter to restore seat width.
 - If it is too low (closer to the valve edge), you must make a second cut with the 30° cutter to move it up, then one more cut with the 45° cutter to restore seat width.

NOTE: The final cut should always be made with the 45° cutter.

7. Insert the intake and exhaust valves in the head and measure the valve stem installed height.

Intake, Exhaust Stem Installed Height:

Standard (New): 53.17 – 53.64 mm
(2.093 – 2.112 in)

Service Limit: 53.89 mm (2.122 in)

8. If the valve stem installed height is over the service limit, replace the valve and recheck. If its still over the service limit, replace the cylinder head; the valve seat in the head is too deep.

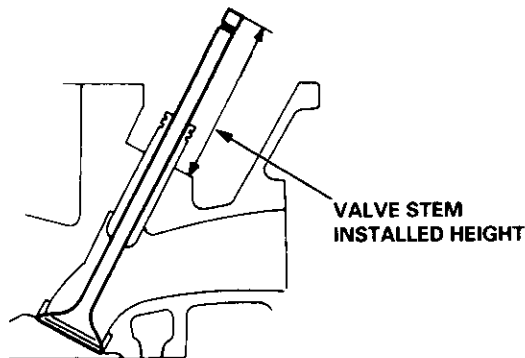

Replacement

1. As illustrated below, use a commercially-available air-impact valve guide driver attachment modified to fit the diameter of the valve guides. In most cases, the same procedure can be done using the special tool and a conventional hammer.

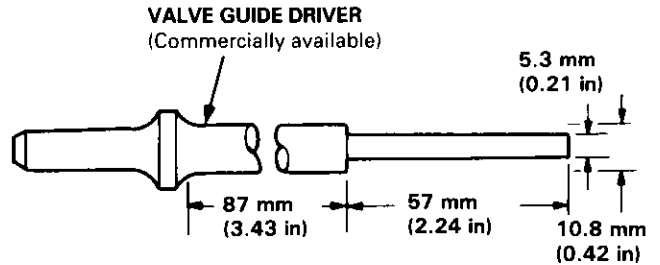

or
VALVE GUIDE DRIVER, 5.5 mm
07742 – 0010100

2. Select the proper replacement guides, and chill them in the freezer section of a refrigerator for about an hour.
3. Use a hot plate or oven to evenly heat the cylinder head to 300°F (150°C). Monitor the temperature with a cooking thermometer.

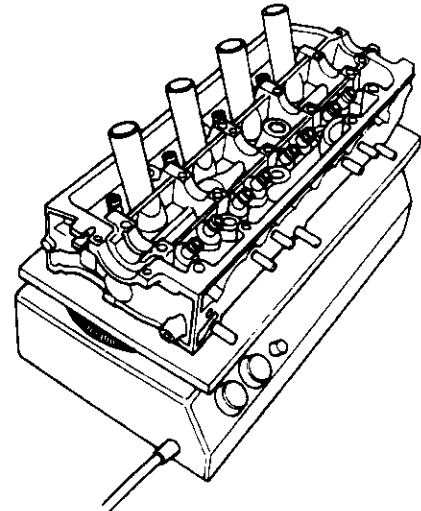

CAUTION:

- Do not use a torch; it may warp the head.
- Do not get the head hotter than 300°F (150°C); excessive heat may loosen the valve seats.
- To avoid burns, use heavy gloves when handling the heated cylinder head.

(cont'd)

Valve Guides

Replacement (cont'd)

- Working from the camshaft side, use the driver and an air hammer to drive the guide about 2 mm (0.1 in) towards the combustion chamber. This will knock off some of the carbon and make removal easier.

CAUTION:

- Always wear safety goggles or a face shield when driving valve guides.
- Hold the air hammer directly in line with the valve guide to prevent damaging the driver.

- Turn the head over, and drive the guide out toward the camshaft side of the head.

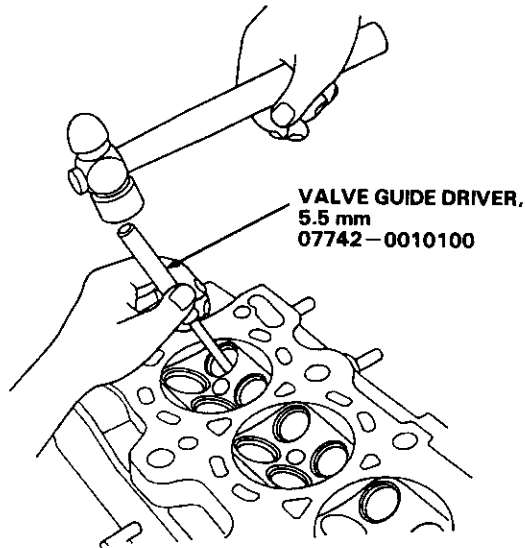
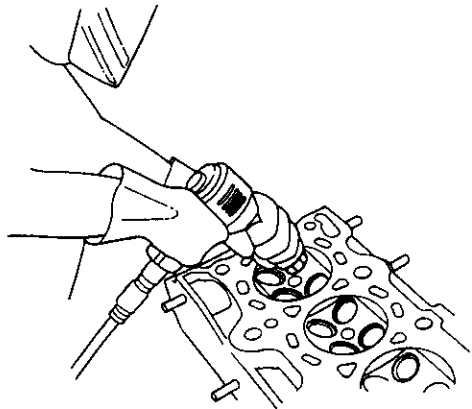

If a valve guide still won't move, drill it out with a 8 mm (5/16 in) bit, then try again.

CAUTION: Drill guides only in extreme cases; you could damage the cylinder head if the guide breaks.

- Remove the new guides from the freezer, one at a time, as you need them.

- Apply a thin coat of clean engine oil to the outside of the new valve guide. Install the guide from the camshaft side of the head; use the special tool to drive the guide in to the specified installed height. If you have all 16 guides to do, you may have to reheat the head.

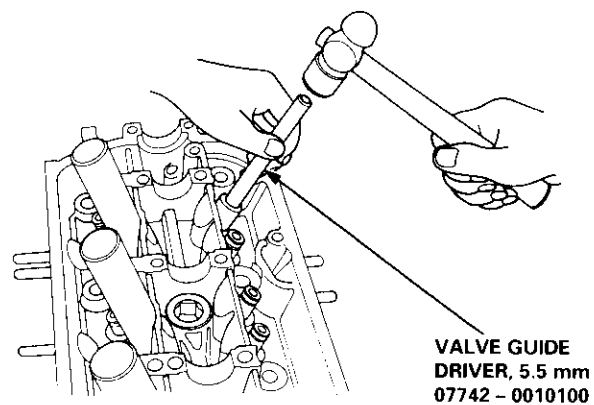

Valve Guide Installed Height:

Intake: 17.85 – 18.35 mm (0.703 – 0.722 in)

Exhaust: 18.65 – 19.15 mm (0.734 – 0.754 in)

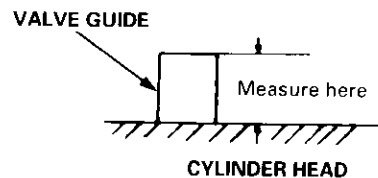



Valves

Reaming

NOTE: For new valve guides only.

1. Coat both the reamer and valve guide with cutting oil.
2. Rotate the reamer clockwise the full length of the valve guide bore.
3. Continue to rotate the reamer clockwise while removing it from the bore.
4. Thoroughly wash the guide in detergent and water to remove any cutting residue.
5. Check the clearance with a valve (see page 6-39). Verify that the valve slides in the valve guide without exerting pressure.

Turn reamer in clockwise direction only.

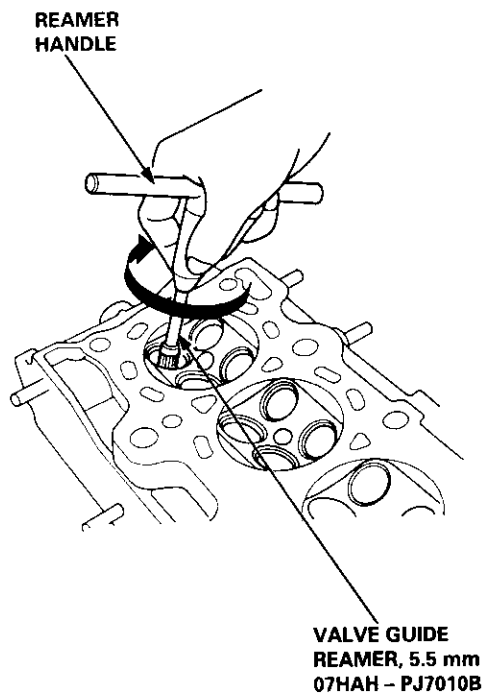

Installation

1. Coat valve stems with engine oil. Insert the valves in the valve guides.

NOTE: Make sure the valves move up and down smoothly.

2. Install the spring seats on the cylinder head.
3. Install the valve seals using the valve guide seal installer.

NOTE: Exhaust and intake valve seals are not interchangeable.

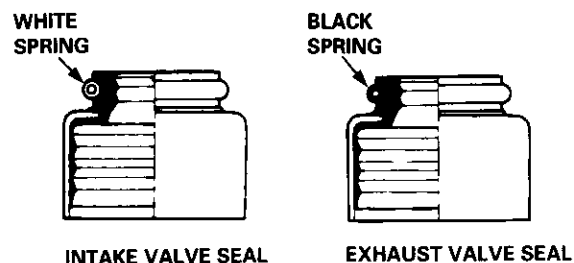

VALVE GUIDE SEAL INSTALLER
KD2899 (Commercially available)
NOTE: Use small ID end of tool.

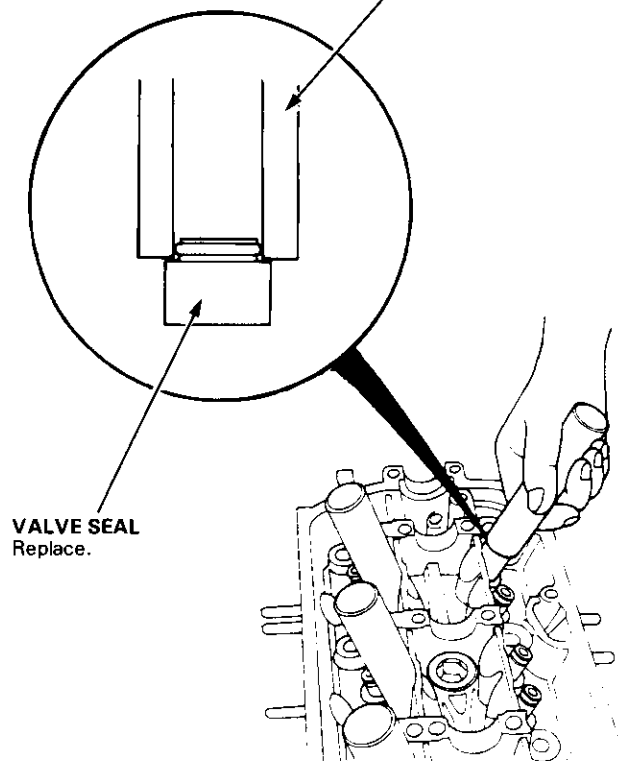

(cont'd)

Installation (cont'd)

4. Install the valve spring and valve retainer, then install the valve spring compressor. Compress the spring and install the valve keepers.

NOTE: Place the end of the valve spring with closely wound coils toward the cylinder head.

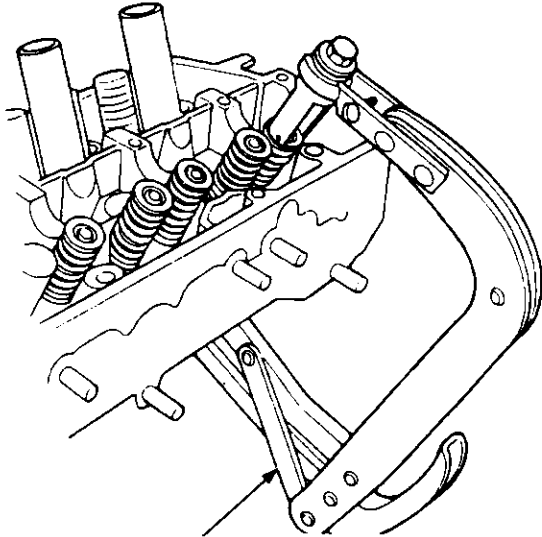

VALVE SPRING COMPRESSOR
(Commercially available)
Snap-on CF711 or KD - 383
with #32 JAWS

5. Lightly tap the end of each valve stem two or three times with a plastic mallet to ensure proper seating of the valve and valve keepers.

NOTE: Tap the valve stem only along its axis so you do not bend the stem.

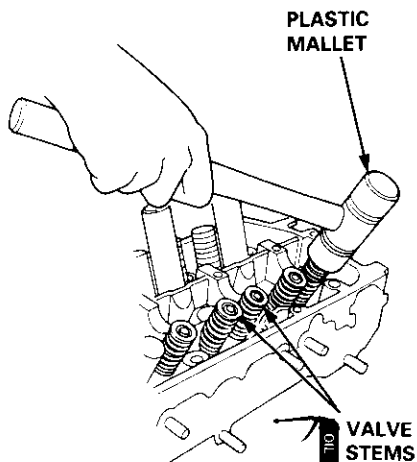

PLASTIC MALLETT

VALVE STEMS

Installation

CAUTION:

- Make sure that all rockers are in alignment with their valves when torquing the rocker assembly bolts.
- Valve locknuts should be loosened and adjusting screws backed off before installation.
- To prevent the rocker arm assembly from coming apart, leave the camshaft holder bolts in the holders.

1. After wiping down the camshaft, camshaft seal and journals in the cylinder head, lubricate both surfaces and install the camshaft.
2. Clean and install the oil control orifice with a new O-ring.

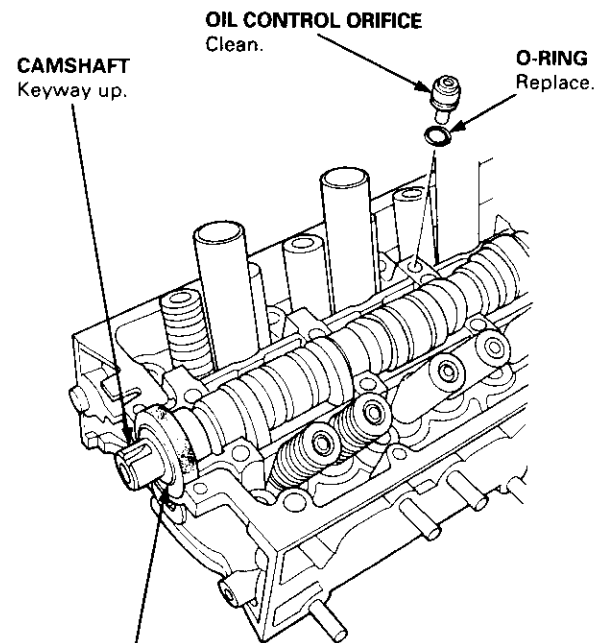

CAMSHAFT SEAL

Seal housing surface should be dry.
Apply a light coat of oil to camshaft and inner lip of seal.

3. Turn the camshaft until its keyway is facing up (No. 1 piston TDC).



4. Apply liquid gasket (Part No. 08718 - 0001 or 08718 - 0003) to the head mating surfaces of the No. 1 and No. 5 camshaft holders.
 - Apply liquid gasket to the shaded areas.

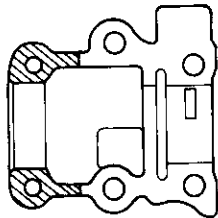

No. 5

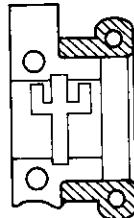

No. 1

5. Set the rocker arm assembly in place and loosely install the bolts.
 - Make sure that the rocker arms are properly positioned on the valve stems.
6. Tighten each bolt two turns at a time in the sequence shown below to ensure that the rockers do not bind on the valves.

Specified torque:

8 mm bolts: 20 N·m (2.0 kgf·m, 14 lbf·ft)

Apply engine oil to the threads.

6 mm bolts: 12 N·m (1.2 kgf·m, 8.7 lbf·ft)

Apply engine oil to the threads.

6 mm bolts: ⑪, ⑫, ⑬, ⑭

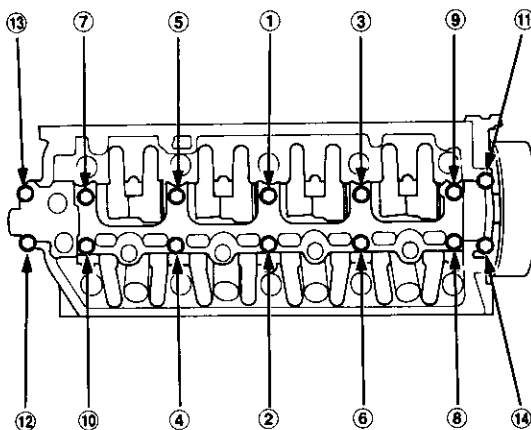

7. Install the back cover, then install the camshaft pulley.

Installation

Install the cylinder head in the reverse order of removal:

NOTE:

- Always use a new head gasket.
- Cylinder head and cylinder block surface must be clean.
- "UP" mark on the camshaft pulley should be at the top.
- Turn the crankshaft so the No. 1 piston is at TDC (see page 6-20).
- Clean the oil control orifice before installing.
- Do not use the upper cover and lower cover to store removed items.
- Clean the upper cover and lower cover before installation.

1. Cylinder head dowel pins must be aligned.

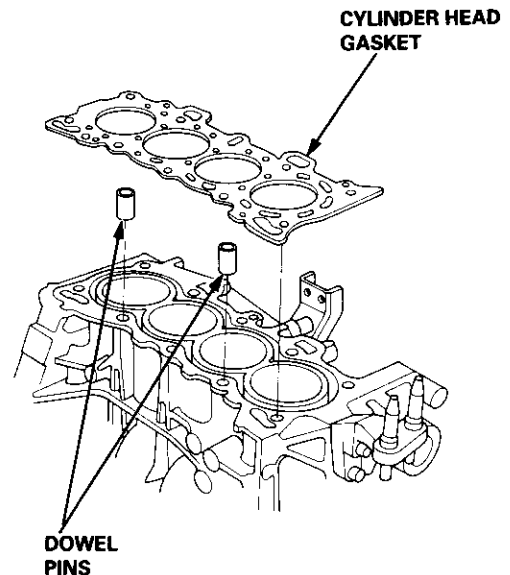

(cont'd)

Cylinder Head

Installation (cont'd)

2. Position the camshaft correctly (see page 6-20).
3. Tighten the cylinder head bolts sequentially in four steps.

1st step: ① – ⑩ 20 N·m (2.0 kgf·m, 14 lbf·ft)

2nd step: ① – ⑩ 49 N·m (5.0 kgf·m, 36 lbf·ft)

3rd step: ① – ⑩ 67 N·m (6.8 kgf·m, 49 lbf·ft)

4th step: ①, ② 67 N·m (6.8 kgf·m, 49 lbf·ft)

NOTE:

- We recommend using a beam-type torque wrench. When using a preset-type torque wrench, be sure to tighten slowly and not to overtighten.
- If a bolt makes any noise while you are torquing it, loosen the bolt, and retighten it from the 1st step.

CYLINDER HEAD BOLTS TORQUE SEQUENCE:

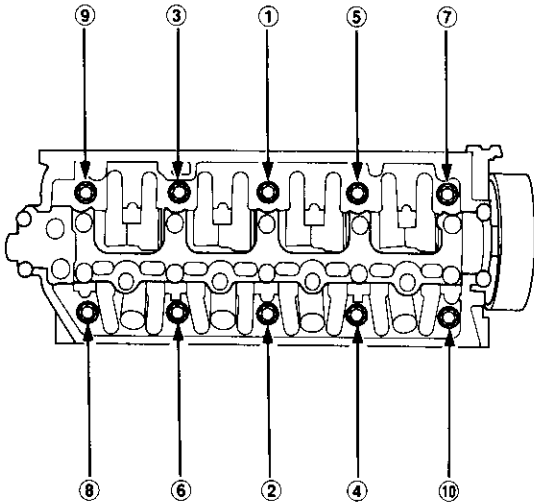

4. Install the intake manifold and tighten the nuts in a crisscross pattern in two or three steps, beginning with the inner nuts (see pages 9-2 thru 9-4).
 - Always use a new intake manifold gasket.
5. Install the exhaust manifold and tighten the nuts in a crisscross pattern in two or three steps, beginning with the inner nut (see pages 9-6 and 9-7).
 - Always use a new exhaust manifold gasket.
6. Install the exhaust manifold bracket. Install the exhaust pipe A and the bracket, then install the cover.

7. Install the timing belt (see page 6-20).
8. Adjust the valve clearance (see page 6-12).
9. Install the head cover gasket in the groove of the cylinder head cover. Seat the recesses for the camshaft first, then work it into the groove around the outside edges.

NOTE:

- Before installing the head cover gasket, thoroughly clean the seal and the groove.
- When installing, make sure the head cover gasket is seated securely in the corners of the recesses with no gap.

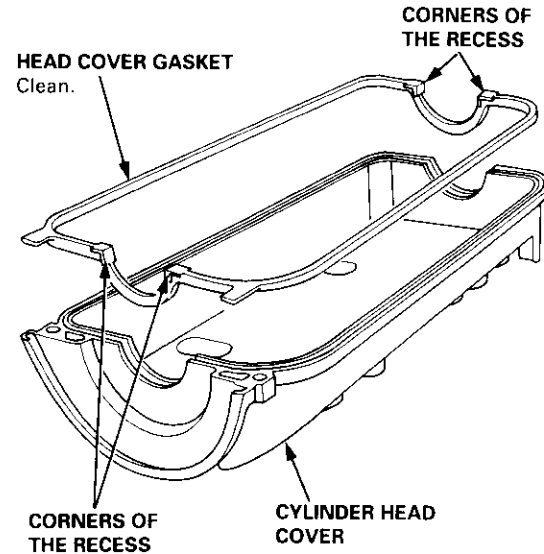

10. Apply liquid gasket to the head cover gasket at the four corners of the recesses.

NOTE:

- Use liquid gasket, Part No. 08718 – 0001 or 08718 – 0003.
- Check that the mating surfaces are clean and dry before applying liquid gasket.
- Do not install the parts if five minutes or more have elapsed since applying liquid gasket. Instead, reapply liquid gasket after removing old residue.
- After assembly, wait at least 30 minutes before filling the engine with oil.

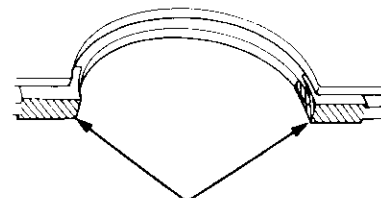

Apply liquid gasket to the shaded areas.



11. When installing the cylinder head cover, hold the head cover gasket in the groove by placing your fingers on the camshaft holder contacting surfaces (top of the semicircles).
Set the spark plug seal on the spark plug tube.
Once the cylinder head cover is on the cylinder head, slide the cover slightly back and forth to seat the head cover gasket.

NOTE:

- Before installing the cylinder head cover, clean the cylinder head contacting surfaces with a shop towel.
- Do not touch the parts where liquid gasket was applied.
- Take care not to damage the spark plug seals when installing the cylinder head cover.
- Visually check the spark plug seals for damage.
- Replace any washer that is damaged or deteriorated.

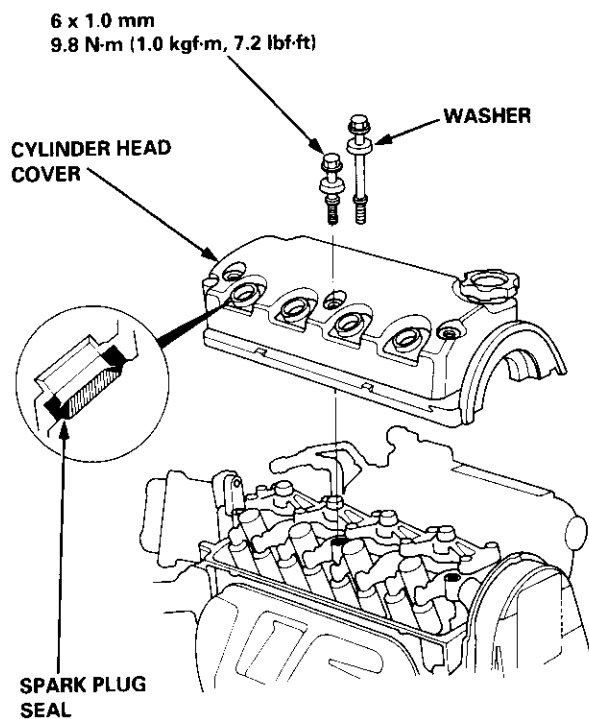

12. Tighten the nuts in two or three steps. In the final step, tighten all bolts, in sequence, to 9.8 N·m (1.0 kgf·m, 7.2 lbf·ft).

NOTE: After assembly, wait at least 30 minutes before filling the engine with oil.

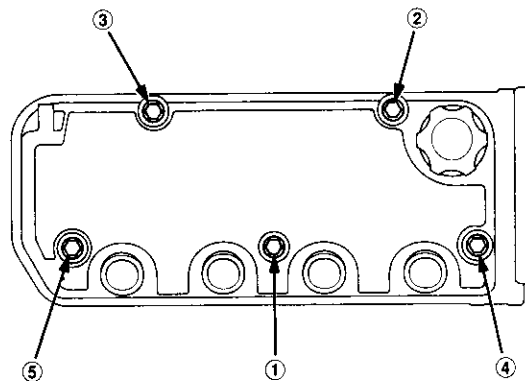

13. After installation, check that all tubes, hoses and connectors are installed correctly.

Cylinder Head/Valve Train B16A2 engine

Special Tools	6-50	Rocker Arms	
VTEC Control System		Removal	6-71
Troubleshooting Flowchart	6-51	Disassembly/Reassembly	6-72
VTEC Solenoid Valve		Rocker Arms and Lost Motion Assemblies	
Inspection	6-54	Inspection	6-73
VTEC Rocker Arms		Rocker Arms and Shafts	
Manual Inspection	6-54	Clearance Inspection	6-74
Inspection Using Special Tools	6-55	Camshafts	
Valve Clearance		Inspection	6-75
Adjustment	6-57	Valves, Valve Springs and Valve Seals	
Crankshaft Pulley and Pulley Bolt		Removal	6-77
Replacement	6-59	Valve Seats	
Timing Belt		Reconditioning	6-78
Illustrated Index	6-60	Valve Guides	
Inspection	6-61	Valve Movement	6-79
Tension Adjustment	6-61	Replacement	6-80
Removal	6-62	Reaming	6-81
Installation	6-63	Valves	
Cylinder Head		Installation	6-82
Illustrated Index	6-65	Rocker Arms	
Removal	6-67	Installation	6-83
Warpage	6-79		
Installation	6-84		



Special Tools

Ref. No.	Tool Number	Description	Qty	Page Reference
①	07HAH - PJ7010B	Valve Guide Reamer, 5.5 mm	1	6-81
②	07JAA - 001020A	Socket, 19 mm	1	6-59
③	07JAB - 001020A	Holder Handle	1	6-59
④	07JAB - 001040A	Pulley Holder Attachment, 50 mm	1	6-59
⑤	07LAJ - PR3020A	Air Stopper	1	6-55
⑥	07MAA - PR70100	Tappet Adjuster	1	6-57
⑦	07MAA - PR70120	Tappet Locknut Wrench	1	6-57
⑧	07MAF - PR9010A	Valve Spring Compressor Attachment Extension	1	6-77
⑨	07742 - 0010100	Valve Guide Driver, 5.5 mm	1	6-80, 81
⑩	07757 - PJ1010A	Valve Spring Compressor Attachment	1	6-77

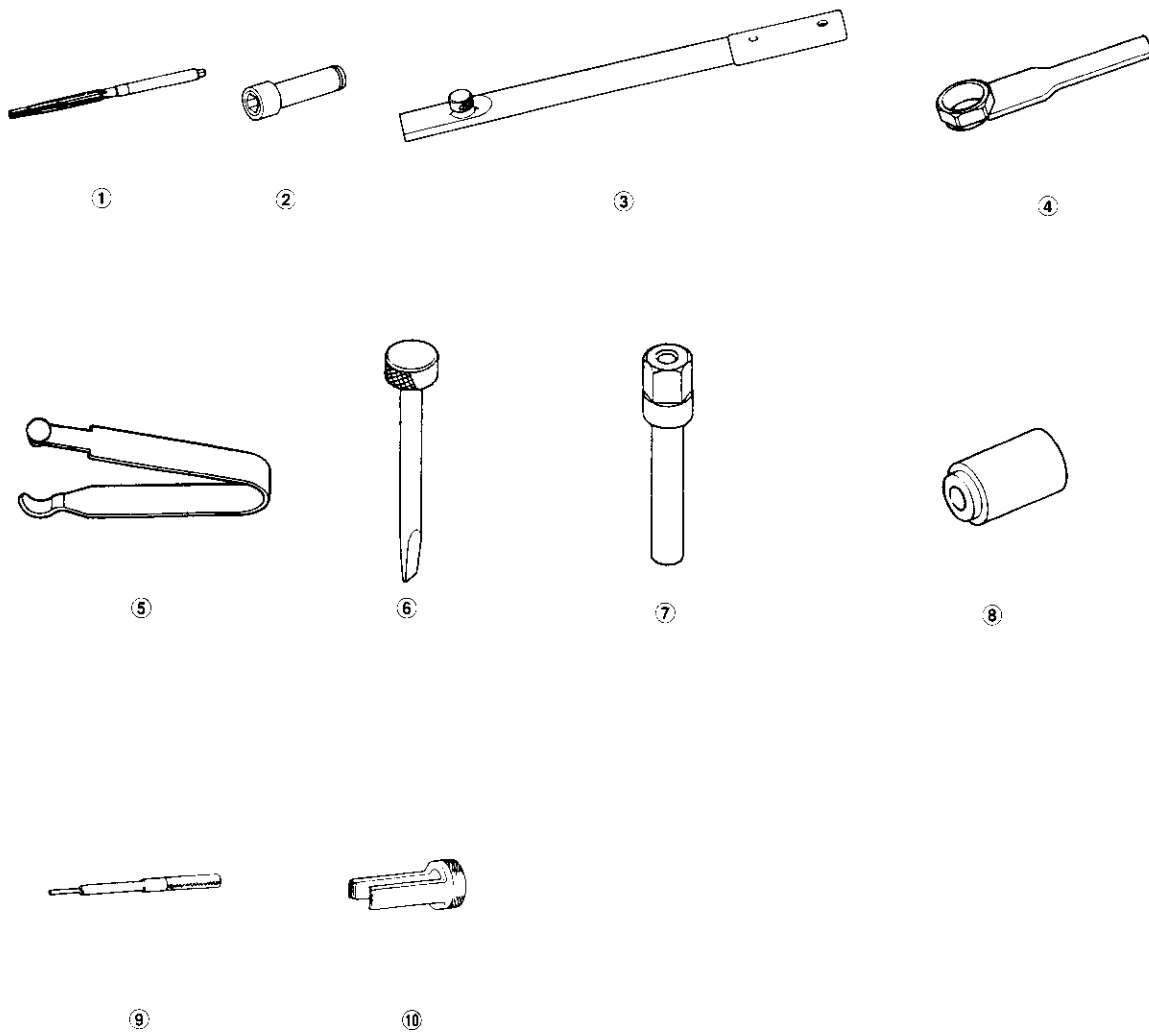



VTEC Control System

Troubleshooting Flowchart

P1259 The scan tool indicates Diagnostic Trouble Code (DTC) P1259: A problem in the VTEC Pressure Switch circuit or VTEC Solenoid Valve circuit.

Refer to page 11-38 through 11-55 before troubleshooting.

— The MIL has been reported on.
— DTC P1259 is stored.

Check the VTEC Control System:
1. Do the engine control module (ECM) Reset Procedure (see section 11).
2. Start the engine.
3. Warm up the engine to normal operating temperature (cooling fan comes on).
4. Do the Road Test.*

* Road Test:
Accelerate in 1st gear to an engine speed over 6,000 rpm. Hold that engine speed for at least two seconds. If the DTC P1259 is not repeated during the first road test, repeat this test two more times.

Is DTC P1259 indicated?

NO
Intermittent failure, system is OK at this time. Check for poor connections or loose wires at VTEC pressure switch, VTEC solenoid valve and ECM.

YES

Test the VTEC Pressure Switch:
1. Turn the ignition switch OFF.
2. Disconnect the VTEC Pressure switch 2P connector.
3. Check for continuity between VTEC pressure switch 2P connector terminal No. 1 and No. 2.

Is there continuity?

NO
Replace the VTEC pressure switch.

YES

Test the VTEC Pressure Switch Wire:
1. Turn the ignition switch ON (II).
2. Measure the voltage between VTEC pressure switch 2P connector No. 1 and body ground.

Is there battery voltage?

NO
Inspect for an open or short to ground in the wire between the VTEC pressure switch and ECM (C10). If the wire is OK, substitute a known-good ECM and recheck.

YES

(To page 6-52)

VTEC PRESSURE SWITCH 2P CONNECTOR

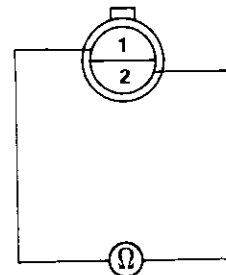

Terminal side of male terminals

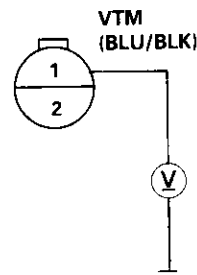

Wire side of female terminals

(cont'd)

VTEC Control System

Troubleshooting Flowchart (cont'd)

(From page 6-51)

Test the VTEC Pressure Switch Wire:
Measure voltage across the VTEC pressure switch 2P connector.

Is there battery voltage?

NO
Repair open in the wire between VTEC pressure switch and G101. If the wire is OK, substitute a known-good ECM and recheck.

YES

Test the VTEC Solenoid Valve:
1. Turn the ignition switch OFF.
2. Disconnect the VTEC solenoid valve 1P connector.
3. Check for continuity between the VTEC solenoid valve 1P connector terminal No. 1 and body ground.

Is there 14 – 30 Ω?

NO
Replace VTEC solenoid valve.

YES

Test the VTEC Solenoid Valve:
1. Remove the VTEC pressure switch and install the special tool as shown, then reinstall the VTEC pressure switch.
2. Reconnect the VTEC solenoid valve 1P connector and VTEC pressure switch 2P connector.
3. Connect the tachometer (see section 11).
4. Start the engine.
5. Warm up engine to normal operating temperature (cooling fan comes on).
6. Check oil pressure at engine speed of 1,000, 3,000 and 5,000 rpm.

Is pressure below 49 kPa (0.5 kgf/cm², 7 psi)?

NO
Inspect the VTEC solenoid valve (see page 6-54).

YES

(To page 6-53)

VTEC PRESSURE SWITCH 2P CONNECTOR

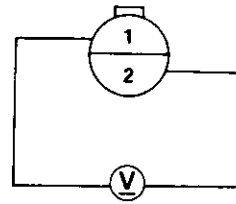

Wire side of female terminals

VTEC SOLENOID VALVE 1P CONNECTOR

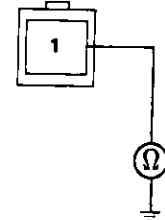

Terminal side of male terminal

OIL PRESSURE GAUGE (Commercially available)

GAUGE JOINT ADAPTER SNAP-ON MT26-17
10 x 1.0 mm
• Use new washer when installing the sealing bolt.

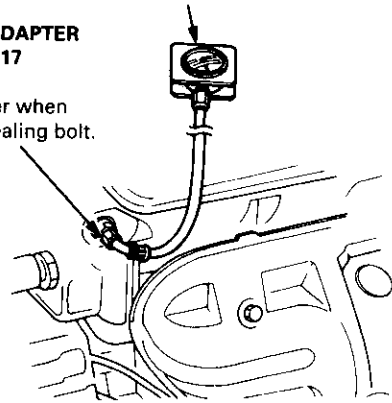

NOTE: Keep measuring time as short as possible because engine is running with no load (less than one minute).



(From page 6-52)

Test the VTEC Solenoid Valve:
 1. Turn the ignition switch OFF.
 2. Disconnect the VTEC solenoid valve 1P connector.
 3. Attach the battery positive terminal to the VTEC solenoid valve terminal.
 4. Start the engine and check the oil pressure at engine speed of 5,000 rpm.

Is the pressure above 390 kPa (4.0 kgf/cm², 57 psi)?

NO → Inspect the VTEC solenoid valve (see page 6-54).

YES

Test the VTEC Pressure Switch:
 With the battery positive terminal connected to the VTEC solenoid valve, measure voltage between the ECM connector terminal C10 and body ground.

Is there battery voltage above 5,000 rpm?

NO → Replace the VTEC pressure switch.

YES

Test the VTEC Solenoid Valve Wire:
 1. Turn the ignition switch OFF.
 2. Check for continuity between the VTEC solenoid valve 1P connector terminal and the ECM connector terminal B12.

Is there continuity?

NO → Repair open in the wire between the ECM (B12) and VTEC solenoid valve connector.

YES

Test the VTEC Solenoid Valve Wire:
 Check for continuity between the VTEC solenoid valve 1P connector terminal and body ground.

Is there continuity?

YES → Repair short in the wire between the ECM (B12) and VTEC solenoid valve connector.

NO

Substitute a known-good ECM and recheck. If symptom/indication goes away, replace the original ECM.

VTEC SOLENOID VALVE 1P CONNECTOR

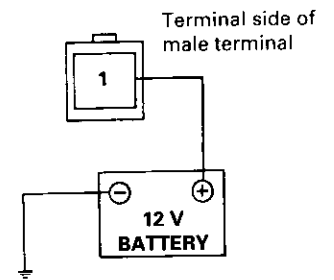

ECM CONNECTOR C (31P)

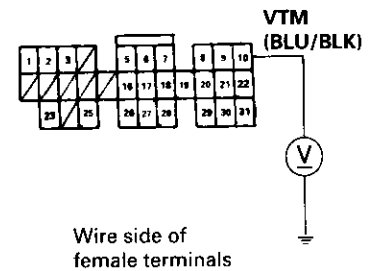

VTEC SOLENOID VALVE 1P CONNECTOR

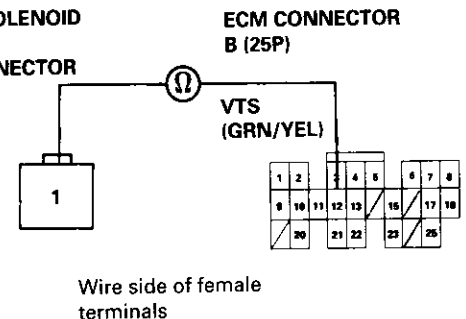

VTEC SOLENOID VALVE 1P CONNECTOR

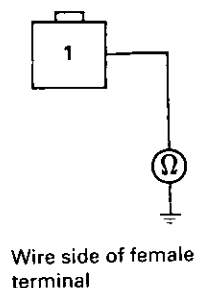

VTEC Solenoid Valve

VTEC Rocker Arms

Inspection

1. Remove the VTEC solenoid valve assembly from the cylinder head, and check the VTEC solenoid valve filter for clogging.
 - If there is clogging, replace the engine oil filter and engine oil.

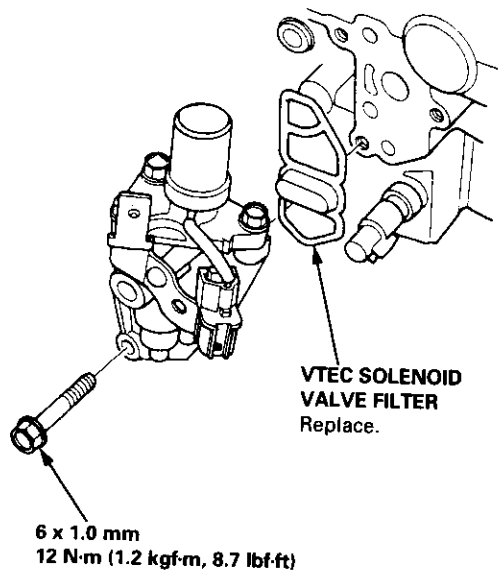

2. If the filter is not clogged, push the VTEC solenoid valve with your finger and check its movement.
 - If the VTEC solenoid valve is normal, check the engine oil pressure.

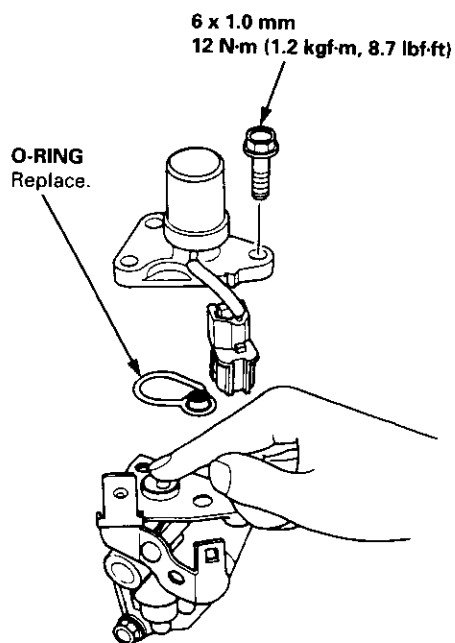

Manual Inspection

1. Set the No. 1 piston at TDC.
2. Remove the ignition wire cover and the wires.
3. Remove the ignition clamps while pulling up on the lock.





4. Remove the cylinder head cover.

NOTE: Refer to page 6-88 when installing the cylinder head cover.

5. Push the mid rocker arm on the No. 1 cylinder manually.
6. Check that the mid rocker arm moves independently of the primary and secondary rocker arms.

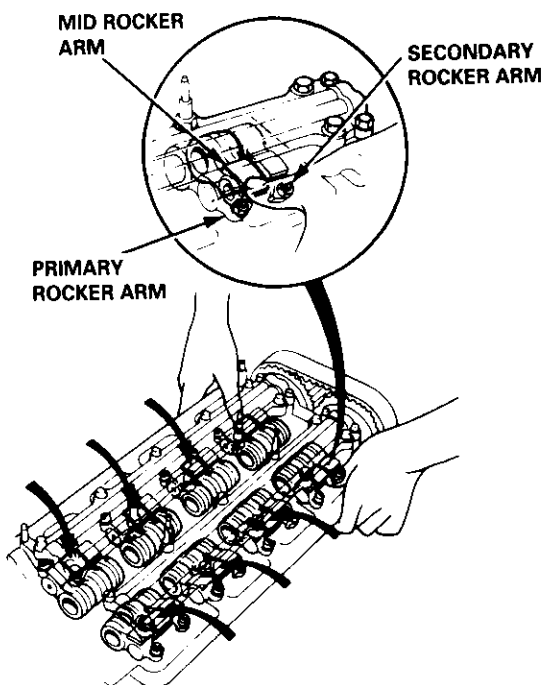

7. Check the mid rocker arm of each cylinder at TDC.

- If the mid rocker arm does not move, remove the mid, primary and secondary rocker arms as an assembly and check that the pistons in the mid and primary rocker arms move smoothly.
- If any rocker arm needs replacing, replace the primary, mid, and secondary rocker arms as an assembly.

Inspection Using Special Tools

CAUTION:

- Before using the valve inspection tool, make sure that the air pressure gauge on the air compressor indicates over 400 kPa (4 kgf/cm², 57 psi)
- Inspect the valve clearance before rocker arm inspection.
- Cover the timing belt with a shop towel to prevent getting oil on the belt.
- Check the mid rocker arm of each cylinder at TDC.

1. Remove the cylinder head cover.

NOTE: Refer to page 6-86 when installing the cylinder head cover.

2. Plug the relief hole with the special tool (Air Stopper).

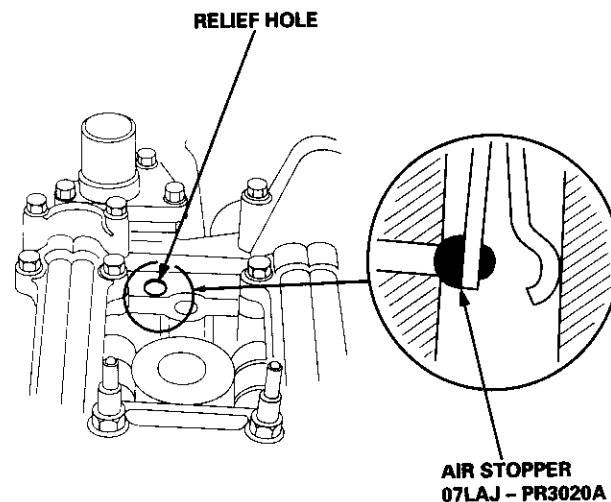

3. Remove the bolt and washer from the inspection hole and connect the an air pressure regulator with a 0 - 100 psi gauge.

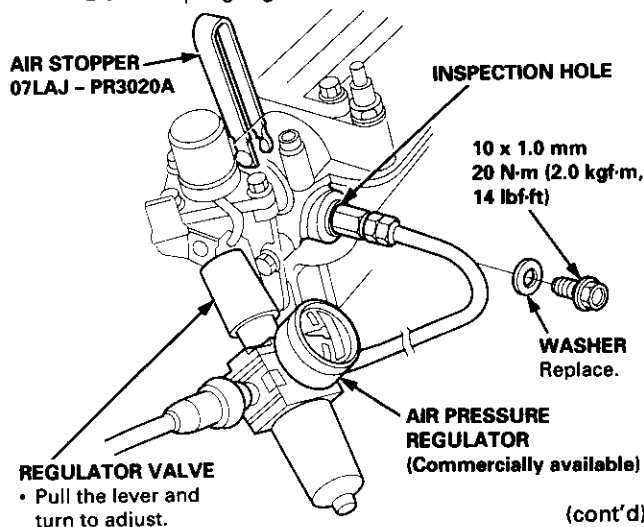

(cont'd)

VTEC Rocker Arms

Inspection Using Special Tools (cont'd)

4. Loosen the valve on the regulator and apply the specified air pressure.

Specified Air Pressure:

250 kPa (2.5 kgf/cm², 36 psi)

— 490 kPa (5.0 kgf/cm², 71 psi)

5. Make sure that the primary and secondary rocker arms are mechanically connected by the pistons and that the mid rocker arms do not move when pushed manually.

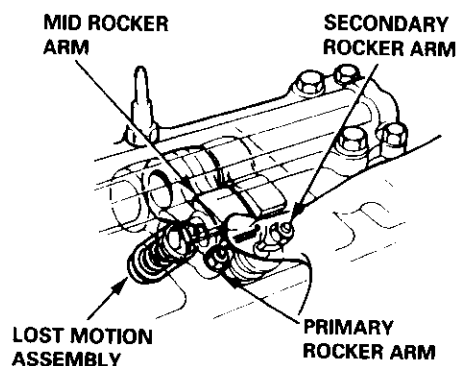

- If any mid rocker arm moves independently of the primary and secondary rocker arms, replace the rocker arms as a set.
6. Remove the tools.
 7. Check the operation of the lost motion assembly by pushing on the mid rocker arm. The lost motion assembly should compress fully and operate smoothly through its full stroke. Replace the assembly if it does not work smoothly.
 8. After inspection, check that the Malfunction Indicator Lamp (MIL) does not come on.



Valve Clearance

Adjustment

NOTE:

- Valves should be adjusted only when the cylinder head temperature is less than 100°F (38°C).
- After adjusting, retorque the crankshaft pulley bolt to 177 N·m (18.0 kgf·m, 130 lbf·ft)

1. Remove the cylinder head cover.

NOTE: Refer to page 6-86 when installing the cylinder head cover.

2. Set No. 1 piston at TDC. The "UP" mark on the pulley should be at the top, and TDC grooves on the pulley should align with the pointer on the back cover. TDC grooves (white paint) on the crankshaft pulley should align with the pointer on the timing belt lower cover.

Number 1 piston at TDC:

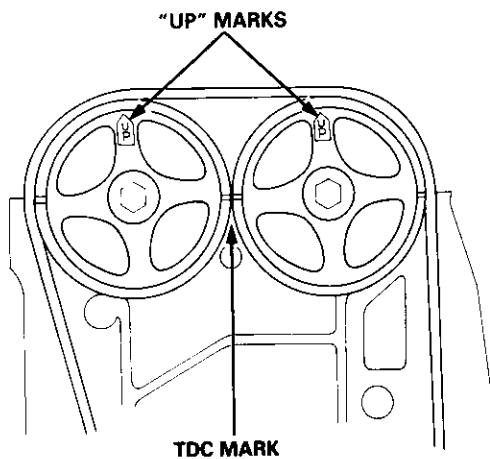

3. Adjust valves on No. 1 cylinder.
Intake: 0.15 – 0.19 mm (0.006 – 0.007 in)
Exhaust: 0.17 – 0.21 mm (0.007 – 0.008 in)

4. Loosen the locknut, and turn the adjusting screw until the feeler gauge slides back and forth with a slight amount of drag.

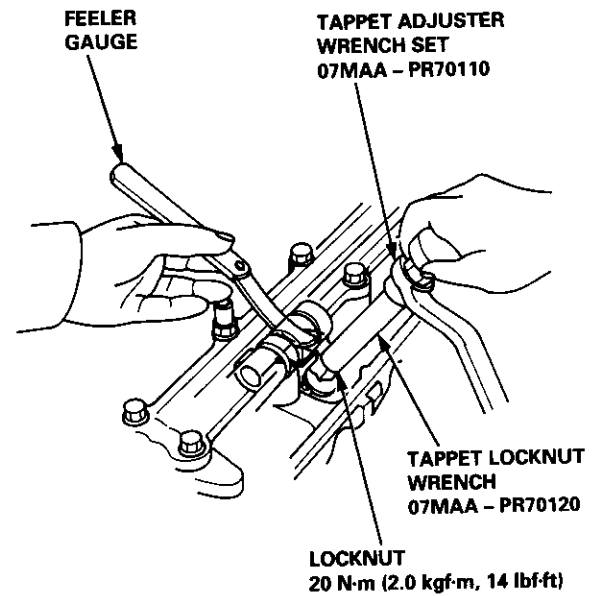

Adjusting screw location:

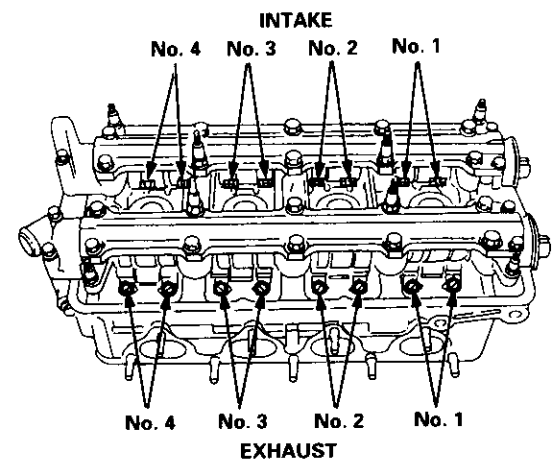

(cont'd)

Valve Clearance

Adjustment (cont'd)

5. Tighten the locknut and recheck clearance. Repeat adjustment if necessary.

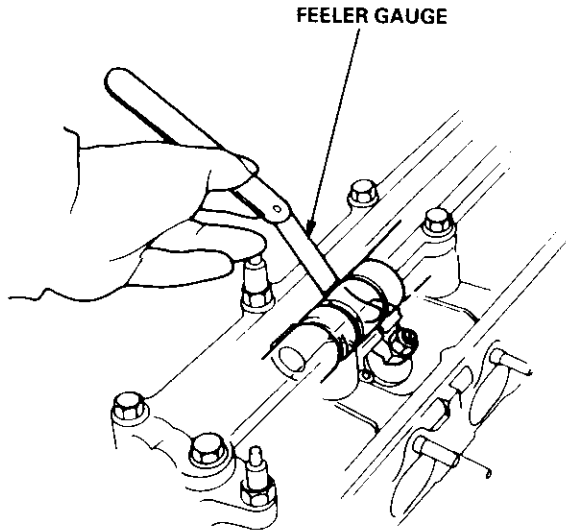

6. Rotate the crankshaft 180° counterclockwise (camshaft pulley turns 90°). The "UP" mark should be on the exhaust side. Adjust valves on No. 3 cylinder.

Number 3 piston at TDC:

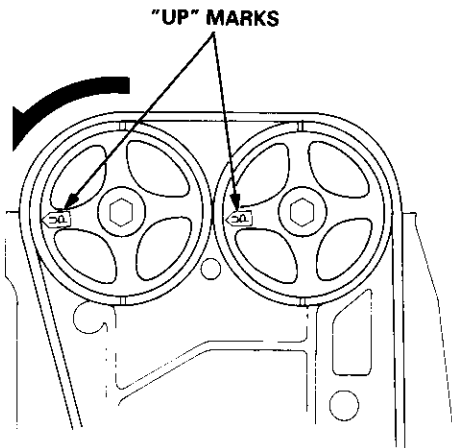

7. Rotate the crankshaft 180° counterclockwise to bring No. 4 piston to TDC. The "UP" mark should be pointing straight down. Adjust valves on No. 4 cylinder.

Number 4 piston at TDC:

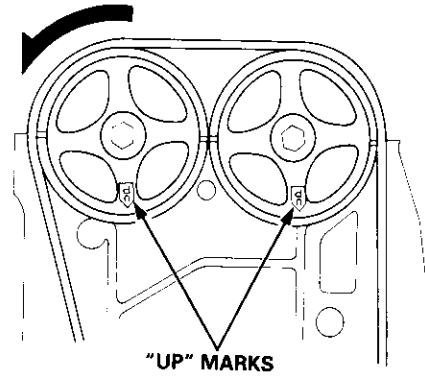

8. Rotate the crankshaft 180° counterclockwise to bring No. 2 piston to TDC. The "UP" marks should be on the intake side. Adjust valves on No. 2 cylinder.

Number 2 piston at TDC:

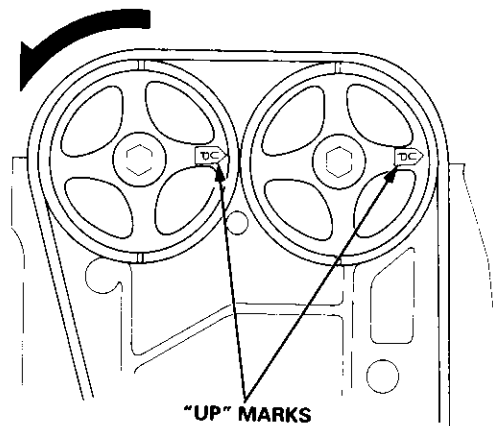



Crankshaft Pulley and Pulley Bolt

Replacement

When installing and tightening the pulley, follow the procedure below.

Clean, remove any oil, and lubricate points shown below.

- : Clean
- ×: Remove any oil
- : Lubricate

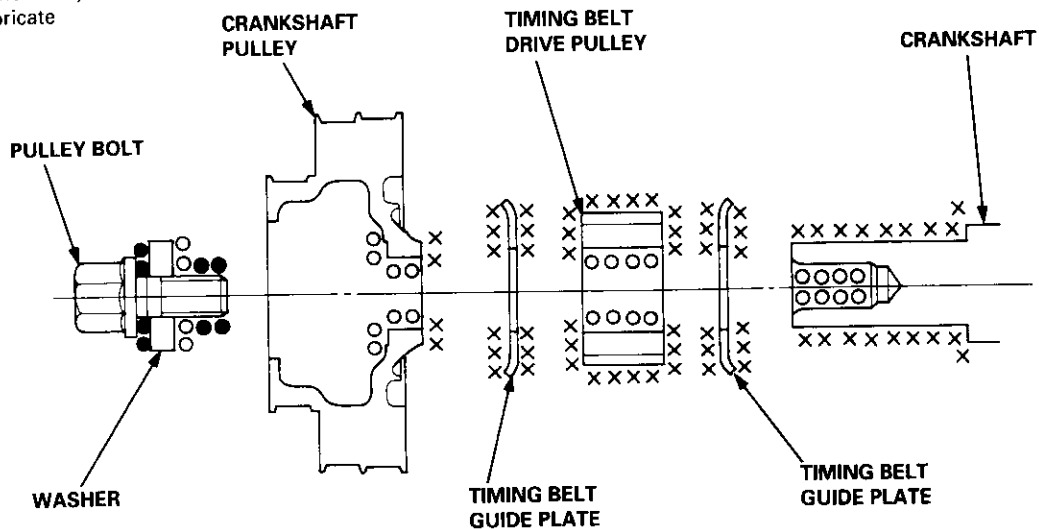

Crankshaft pulley bolt size and torque value:
14 x 1.25 mm
177 N-m (18.0 kgf-m, 130 lbf-ft)

NOTE: Do not use an impact wrench when installing.

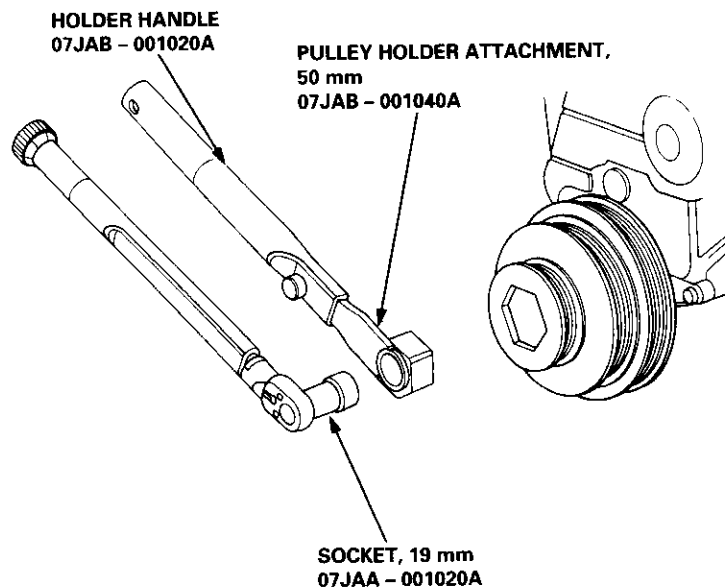

Timing Belt

Illustrated Index

NOTE:

- Refer to page 6-59 for positioning crankshaft and pulley before installing belt.
- Mark the direction of rotation on the belt before removing.
- Do not use the middle cover and lower cover for storing removed items.
- Clean the middle cover and lower cover before installation.

WASHER

Replace when damaged or deteriorated.

CAP NUT

6 x 1.0 mm
9.8 N-m (1.0 kgf-m, 7.2 lbf-ft)

RUBBER SEAL

Replace when damaged or deteriorated.

CYLINDER HEAD COVER

Refer to page 6-86 when installing.

HEAD COVER GASKET

Replace when leaking, damaged or deteriorated. Apply liquid gasket at the four corners of the recesses.

BACK COVER

KEYS

TIMING BELT

Inspection, page 6-61
Adjustment, page 6-61
Replacement, page 6-62

MIDDLE COVER

6 x 1.0 mm
9.8 N-m (1.0 kgf-m, 7.2 lbf-ft)

Clean.

6 x 1.0 mm
9.8 N-m (1.0 kgf-m, 7.2 lbf-ft)

8 x 1.25 mm
56 N-m (5.7 kgf-m, 41 lbf-ft)

6 x 1.0 mm
9.8 N-m (1.0 kgf-m, 7.2 lbf-ft)

Install with concave surface facing in.
Clean.

ADJUSTING BOLT
10 x 1.25 mm
54 N-m (5.5 kgf-m, 40 lbf-ft)

Install with concave surface facing out.
Remove any oil and clean.

TIMING BELT DRIVE PULLEY

Replacement, page 6-59

LOWER COVER

PULLEY BOLT

14 x 1.25 mm
177 N-m (18.0 kgf-m, 130 lbf-ft)
Replacement, page 6-59
Do not use an impact wrench when installing.

CRANKSHAFT PULLEY

Replacement, page 6-59



Inspection

1. Remove the cylinder head cover.

NOTE: Refer to page 6-86 when installing the cylinder head cover.

2. Inspect the timing belt for cracks and oil or coolant soaking.

NOTE:

- Replace the belt if oil or coolant soaked.
- Remove any oil or solvent that gets on the belt.

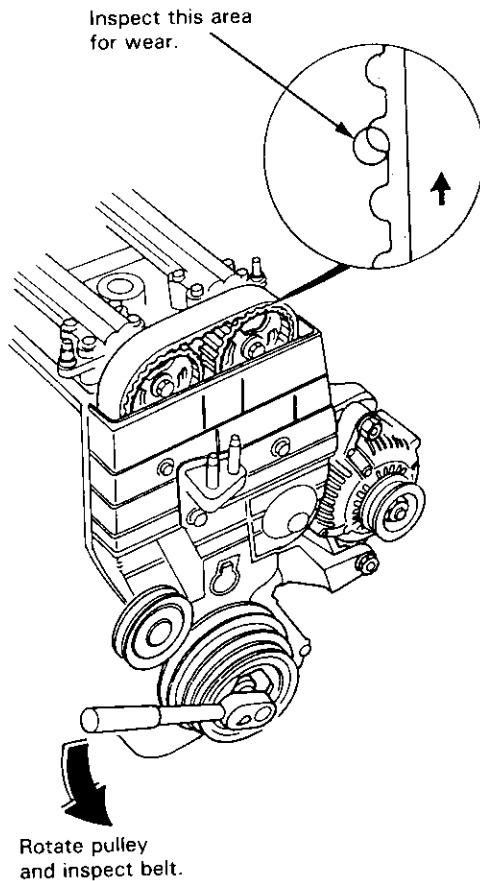

4. After inspecting, retorque the crankshaft pulley bolt to 177 N·m (18.0 kgf·m, 130 lbf·ft).

Tension Adjustment

CAUTION: Always adjust timing belt tension with the engine cold.

NOTE:

- The tensioner is spring-loaded to apply proper tension to the belt automatically after making the following adjustment.
- Always rotate the crankshaft counterclockwise when viewed from the pulley side. Rotating it clockwise may result in improper adjustment of the belt tension.

1. Remove the cylinder head cover.

NOTE: Refer to page 6-86 when installing the cylinder head cover.

2. Set the No. 1 piston at TDC (see page 6-64).
3. Rotate the crankshaft five or six revolutions to set the belt.
4. Set the No. 1 piston at TDC.

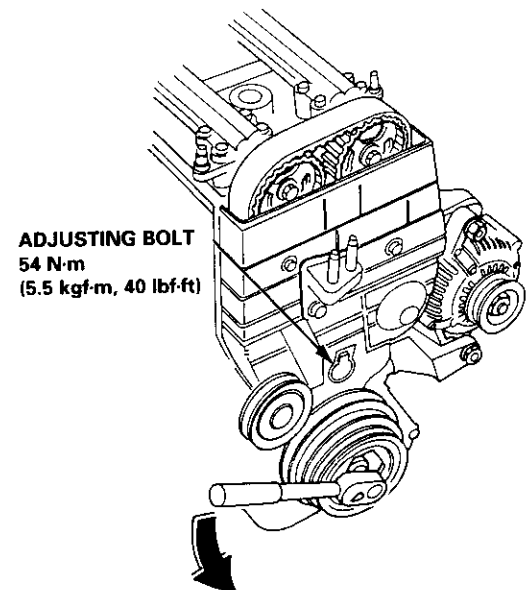

5. Loosen the adjusting bolt 180°.
6. Rotate the crankshaft counterclockwise three teeth on the camshaft pulley.
7. Tighten the adjusting bolt.
8. After adjusting, retorque the crankshaft pulley bolt to 177 N·m (18.0 kgf·m, 130 lbf·ft).

Timing Belt

Removal

NOTE:

- Replace the timing belt at 105,000 miles (168,000 km) according to the maintenance schedule (normal conditions/severe conditions).

If the vehicle is regularly driven in one or more of the following conditions, replace the timing belt at 60,000 miles (U.S.A.) 100,000 km (Canada).

- In very high temperatures (over 110°F, 43°C).
- In very low temperatures (under -20°F, -29°C).
- Turn the crankshaft pulley so the No. 1 piston is at top dead center (TDC) before removing the belt (see page 6-57).
- Inspect the water pump before installing the timing belt (see page 10-14).

1. Remove the splash shield (see page 5-9).
2. Remove the adjusting bolt and mounting bolts, then remove the power steering (P/S) pump belt and pump.

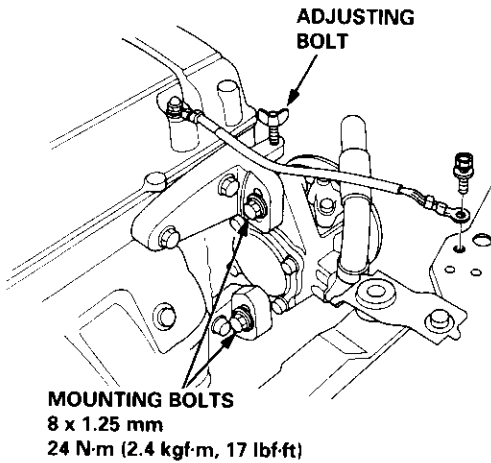

3. Loosen the idler pulley bracket bolt and adjusting bolt, then remove the air conditioning (A/C) compressor belt.

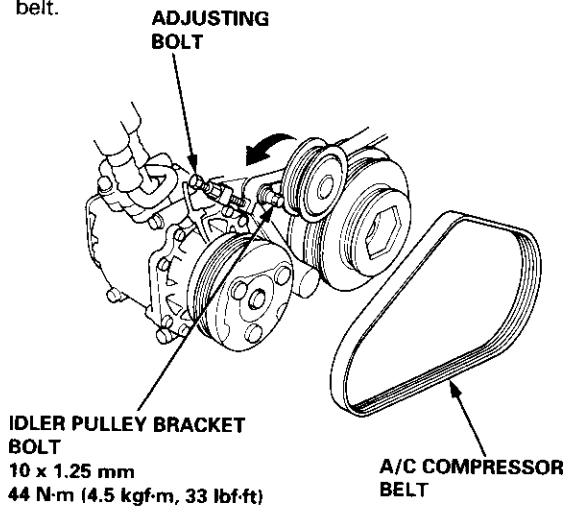

4. Loosen the mounting nut and lock bolt, then remove the alternator belt.

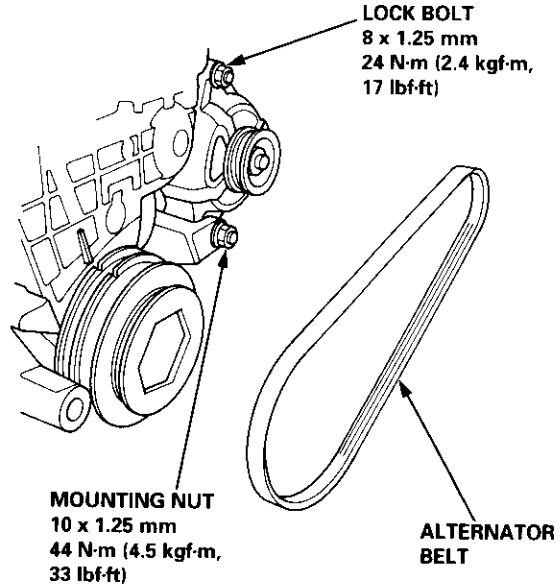

5. Remove the upper bracket (see page 6-69).

NOTE:

- Use a jack to support the engine before removing the upper bracket.
- Place a cushion between the oil pan and the jack.

6. Remove the P/S pump lower bracket.

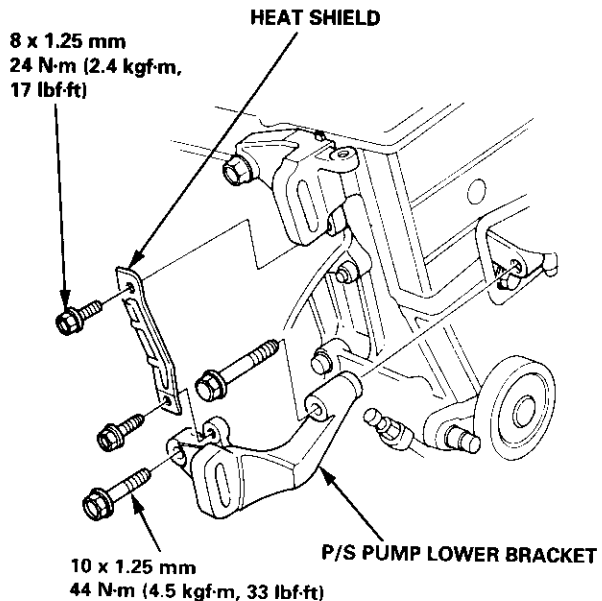



7. Remove the crankshaft pulley (see page 6-59).
8. Remove the cylinder head cover.

NOTE: Refer to page 6-86 when installing the cylinder head cover.

9. Remove the middle cover and lower cover.

NOTE: Do not use the middle and lower covers for storing removed items.

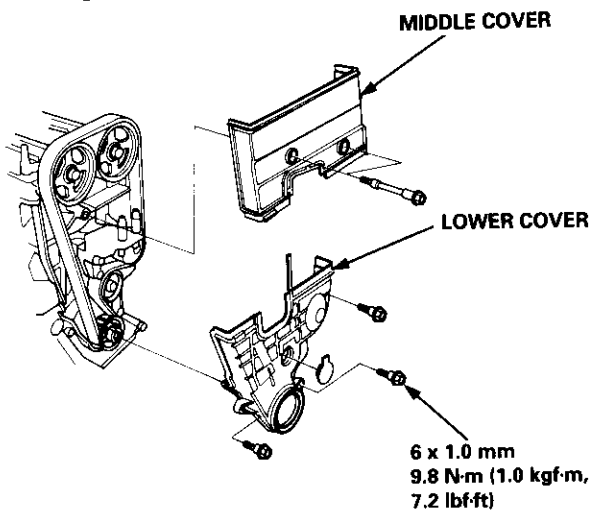

10. Loosen the adjusting bolt 180°. Push the tensioner to remove tension from the timing belt, then retighten the adjusting bolt.

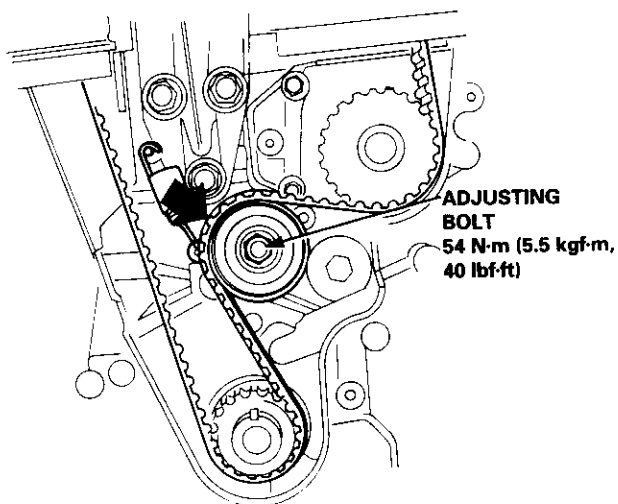

11. Remove the timing belt.

Installation

Install the timing belt in the reverse order of removal; Only key points are described here.

1. Set the timing belt drive pulley so that the No. 1 piston is at top dead center (TDC). Align the groove on the timing belt drive pulley to the ∇ pointer on the oil pump.

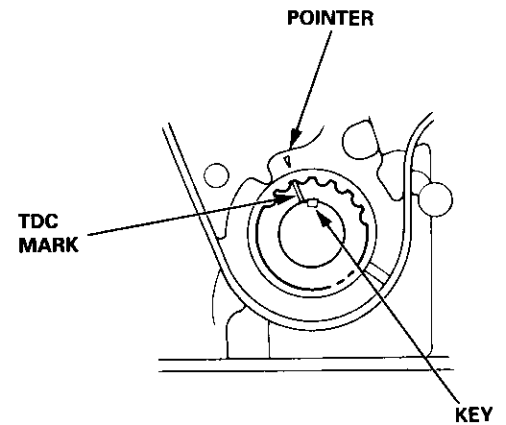

2. Set the camshaft pulleys so that the No. 1 piston is at TDC. Align the TDC marks on the intake and exhaust camshaft pulleys.

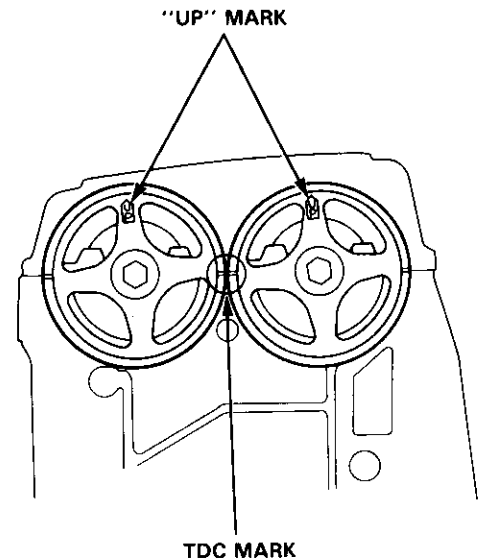

(cont'd)

Timing Belt

Installation (cont'd)

3. Install the timing belt tightly in the sequence shown.
① Timing belt drive pulley (crankshaft) → ② Adjusting pulley → ③ Water pump pulley → ④ Intake camshaft pulley → ⑤ Exhaust camshaft pulley.

NOTE: Make sure the timing belt drive pulley and camshaft pulleys are at TDC.

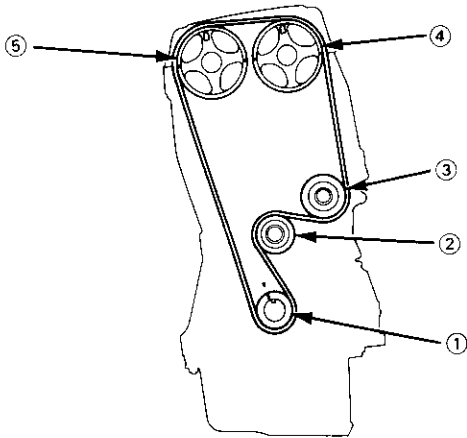

4. Loosen and retighten the adjusting bolt to tension the timing belt.
5. Install the lower cover and middle cover.

NOTE: Clean the middle and lower covers before installing.

6. Install the crankshaft pulley, then tighten the pulley bolt (see page 6-59).
7. Rotate the crankshaft pulley about five or six turns counterclockwise so that the timing belt positions on the pulleys.
8. Adjust the timing belt tension (see page 6-61).

9. Check that the crankshaft pulley and camshaft pulleys are both at TDC.

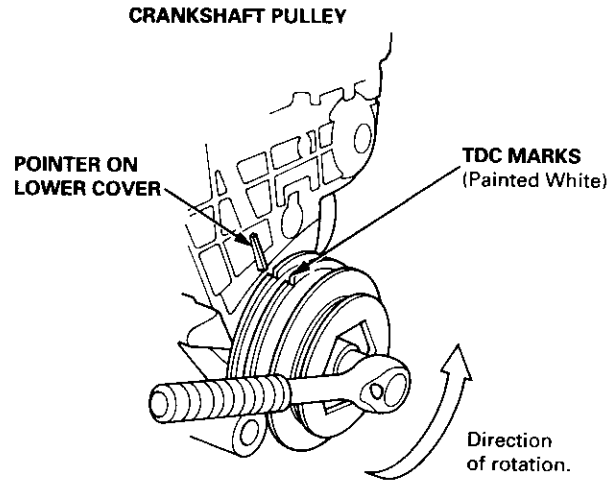

CAMSHAFT PULLEY:

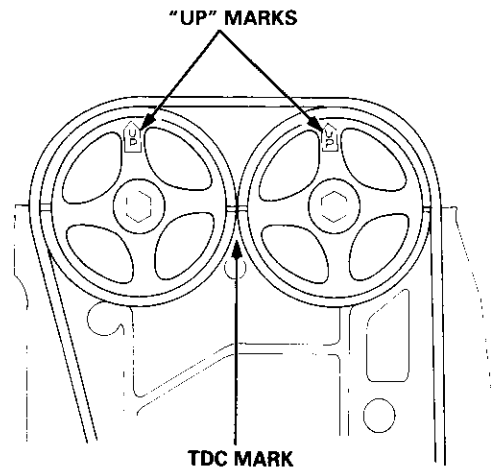

10. If the camshaft and crankshaft pulleys are not positioned at TDC, remove the timing belt, adjust the position following the procedure on page 6-63, then reinstall the timing belt.

11. After installation, adjust the tension of each belt.
- See section 23 for alternator belt tension adjustment.
 - See section 22 for A/C compressor belt tension adjustment.
 - See section 17 for P/S pump belt tension adjustment.



Cylinder Head

Illustrated Index

CAUTION:

- To avoid damaging the cylinder head, wait until the engine coolant temperature drops below 100°F (38°C) before removing it.
- When handling a metal gasket, take care not to fold the gasket or damage the contact surface of the gasket.

NOTE: Use new O-rings and gaskets when reassembling.

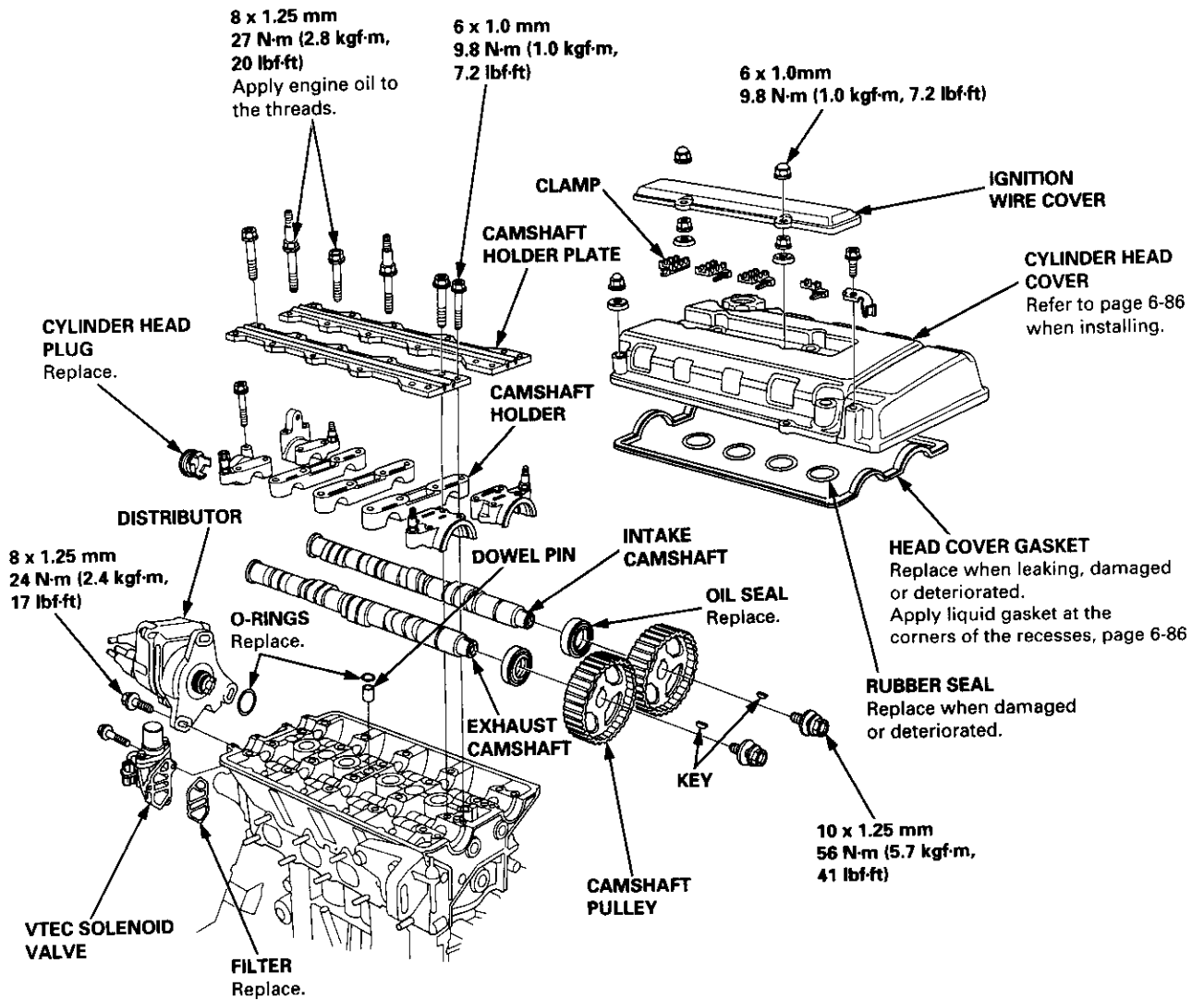

(cont'd)

Cylinder Head

Illustrated Index (cont'd)

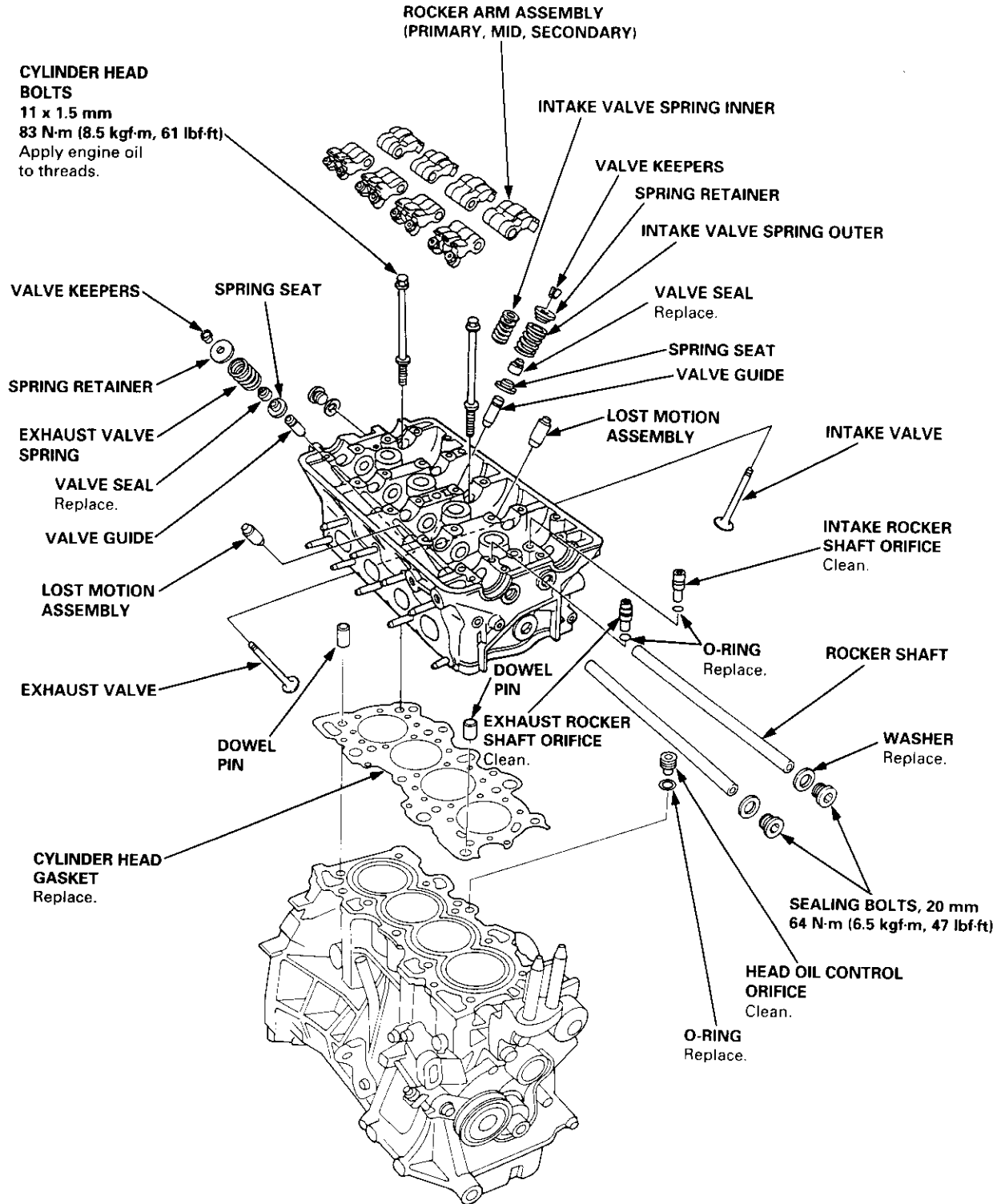



Removal

Engine removal is not required for this procedure.

▲ WARNING Make sure jacks and safety stands are placed properly and hoist brackets are attached to correct position on the engine.

CAUTION:

- Use fender covers to avoid damaging painted surfaces.
- To avoid damage, unplug the wiring connectors carefully while holding the connector portion.
- To avoid damaging the cylinder head, wait until the engine coolant temperature drops below 100°F (38°C) before loosening the retaining bolt.

NOTE:

- Unspecified items are common.
- Mark all wiring and hoses to avoid misconnection. Also, be sure that they do not contact other wiring or hoses or interfere with other parts.
- Inspect the timing belt before removing the cylinder head.
- Turn the crankshaft pulley so that the No. 1 piston is at top dead center (see page 6-64).

1. Disconnect the negative terminal from the battery.
2. Drain the engine coolant (see page 10-7).
 - Remove the radiator cap to speed draining.
3. Remove the strut brace (see page 5-2).
4. Remove the intake air duct and air cleaner housing (see page 5-3).
5. Remove the adjusting bolt and mounting bolt, then remove the power steering (P/S) pump belt and pump (see page 5-5).

6. Loosen the idler pulley bracket bolt and adjusting bolt, then remove the air conditioning (A/C) compressor belt.

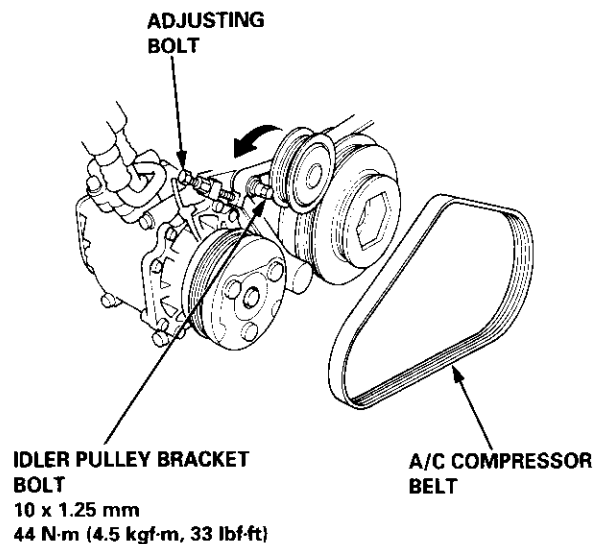

7. Loosen the mounting nut and lock bolt, then remove the alternator belt.

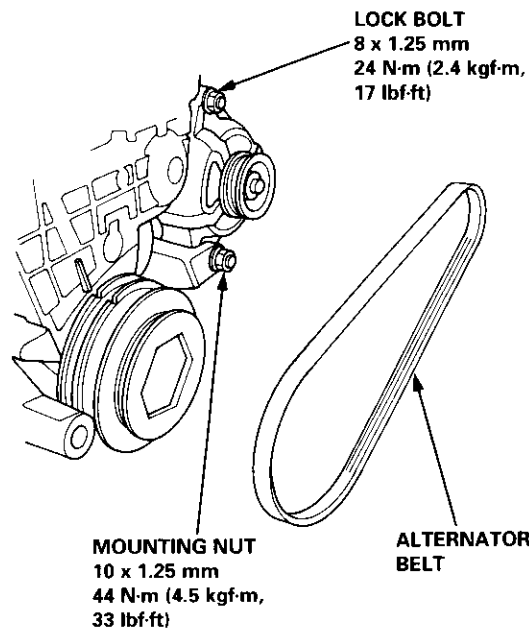

(cont'd)

Cylinder Head

Removal (cont'd)

8. Remove the P/S pump lower bracket.

8 x 1.25 mm
24 N-m (2.4 kgf-m,
17 lbf-ft)

HEAT SHIELD

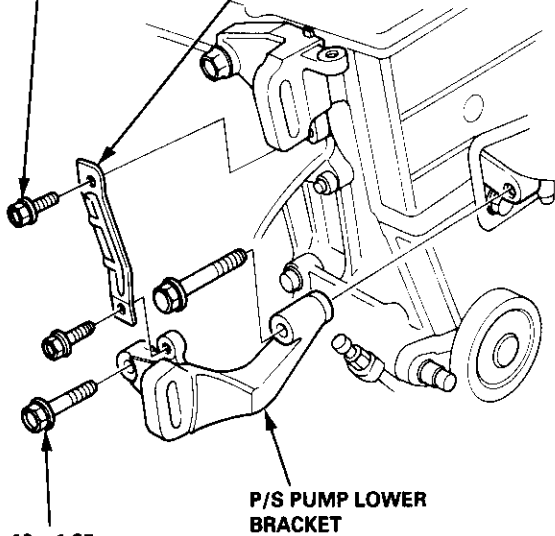

10 x 1.25 mm
44 N-m (4.5 kgf-m,
33 lbf-ft)

9. Relieve fuel pressure (see section 11).

WARNING Do not smoke while working on fuel system, keep open flame or spark away from work area. Drain fuel only into an approved container.

10. Remove the evaporative emission (EVAP) control canister hose, fuel feed hose and breather hose.

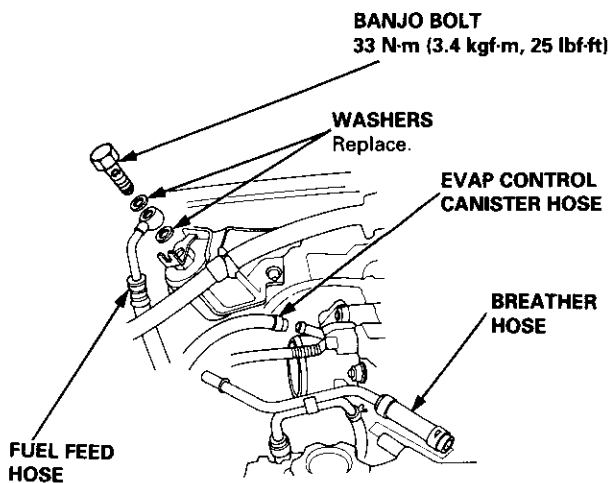

11. Remove the brake booster vacuum hose, fuel return hose and vacuum hose (see page 5-4).

12. Remove the water bypass hose and positive crankcase ventilation (PCV) hose.

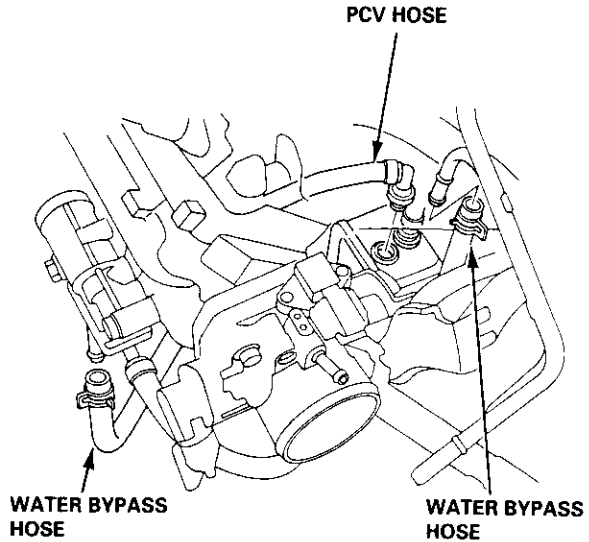

13. Remove the throttle cable and throttle control cable by loosening the locknut, then slip the cable end out of the throttle linkage.

NOTE:

- Take care not to bend the cables when removing them. Always replace any kinked cable with a new one.
- Adjust the throttle cable when installing (see section 11).
- Adjust the throttle control cable when installing (see section 14).

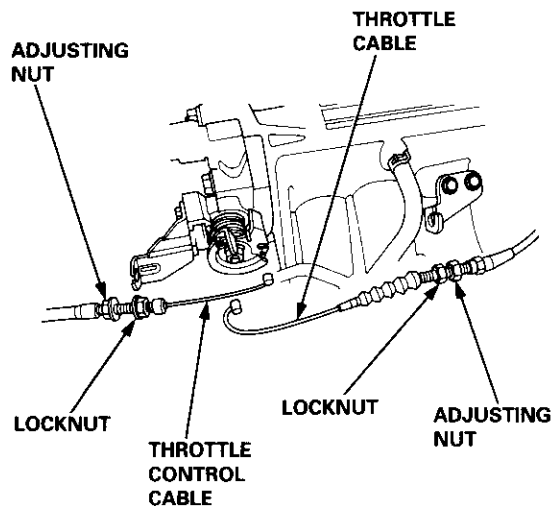



14. Remove the upper radiator hose, heater hose and water bypass hose.

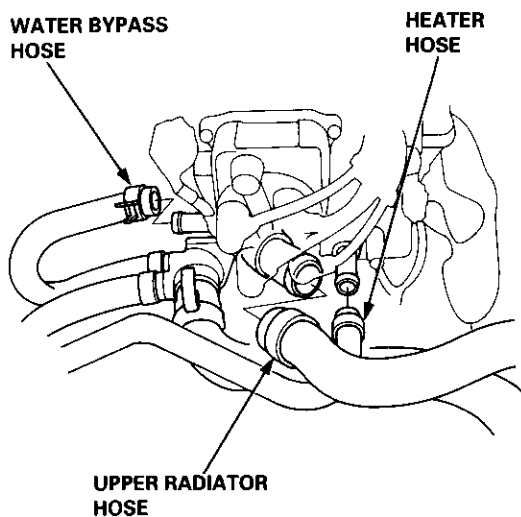

15. Remove the engine wire harness connectors and wire harness clamps from the cylinder head and the intake manifold.

- Four fuel injector connector
- Engine coolant temperature (ECT) sensor connector
- ECT gauge sending unit connector
- ECT switch connector
- Idle air control (IAC) valve connector
- Manifold absolute pressure (MAP) sensor connector
- Throttle position sensor connector
- Primary Heated oxygen sensor (Primary HO2S) connector
- VTEC solenoid valve connector

16. Remove the spark plug caps and distributor from the cylinder head.

17. Remove the upper bracket.

NOTE:

- Use a jack to support the engine before removing the upper bracket is removed.
- Place a cushion between the oil pan and the jack.

12 x 1.25 mm
74 N·m (7.5 kgf·m,
54 lbf·ft)

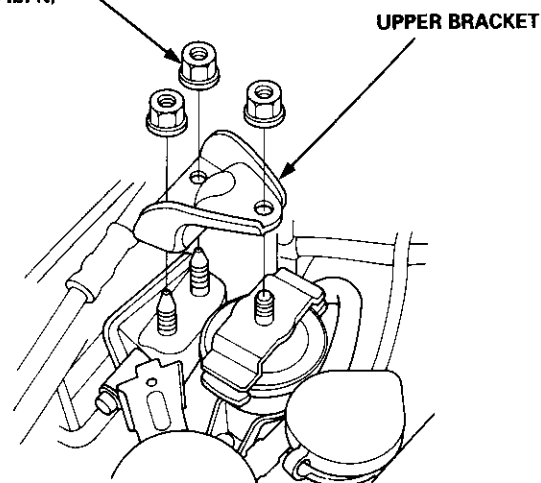

18. Remove the cylinder head cover.

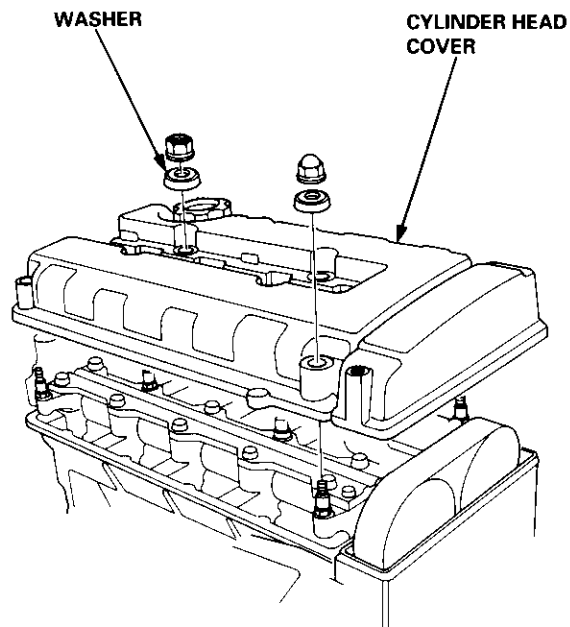

(cont'd)

Cylinder Head

Removal (cont'd)

19. Remove the timing belt (see page 6-62).
20. Remove the back cover and camshaft pulleys.

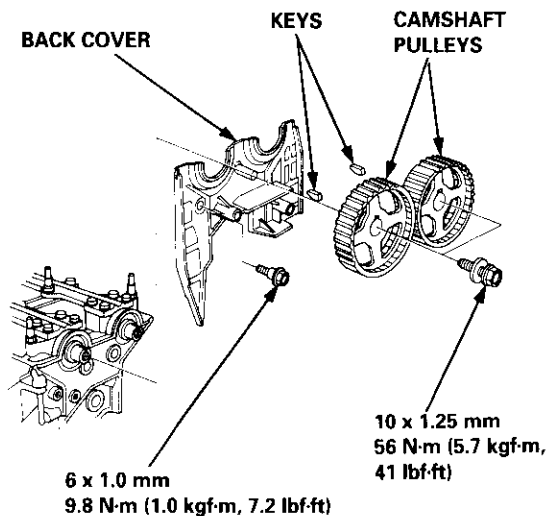

21. Remove the exhaust manifold (see page 9-8).
22. Remove the intake manifold (see page 9-5).
23. Loosen the adjusting screws.

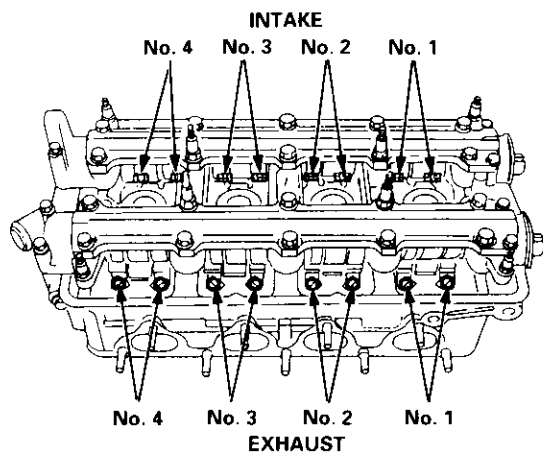

24. Remove the camshaft holder plates, camshaft holders and camshafts.

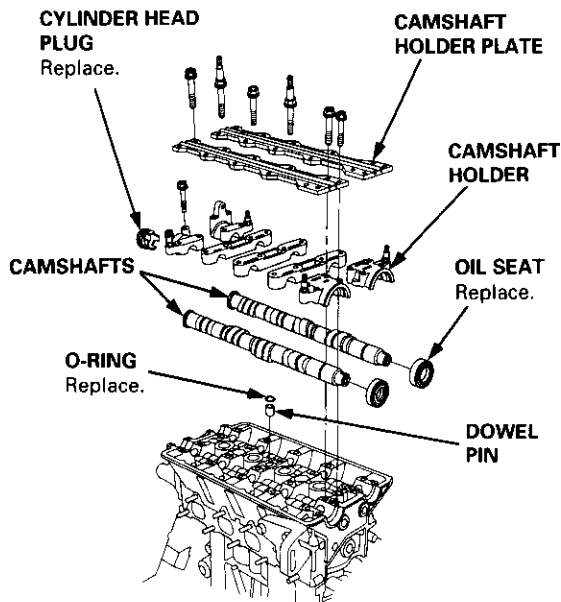

25. Remove the cylinder head bolts, then remove the cylinder head.

CAUTION: To prevent warpage, unscrew the bolts in sequence 1/3 turn at a time; repeat the sequence until all bolts are loosened.

CYLINDER HEAD BOLTS LOOSENING SEQUENCE:

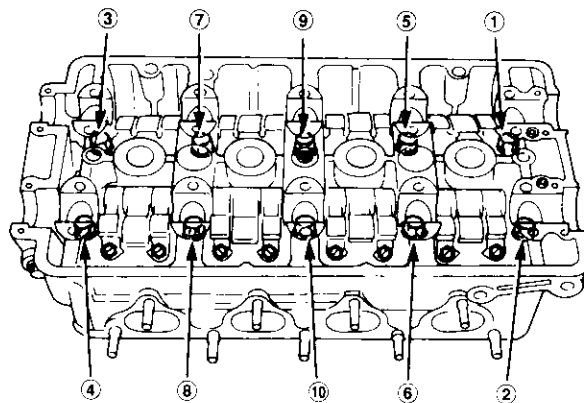

Rocker Arms



Removal

1. Hold the rocker arms together with a rubber band to prevent them from separating.

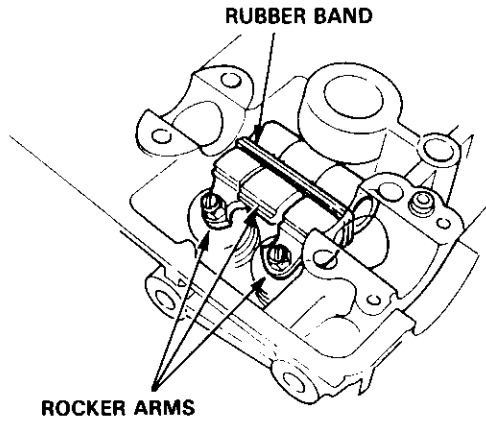

2. Remove the intake and exhaust rocker shaft oil control orifices, then remove the VTEC solenoid valve and the sealing bolts.

NOTE: The shapes of the intake and exhaust oil control orifices are different. Identify the parts as they are removed to ensure reinstallation in the original locations.

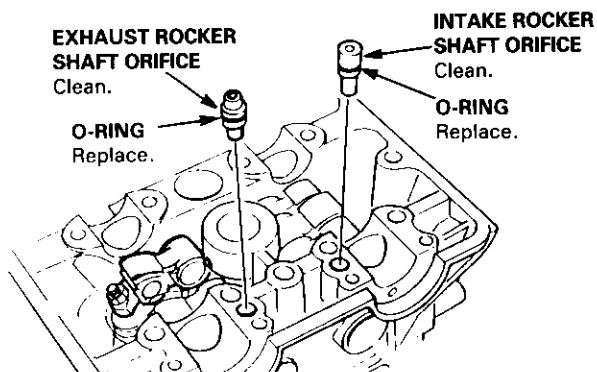

3. Screw 12 mm bolts into the rocker arm shafts. Remove each rocker arm set while slowly pulling out the intake and exhaust rocker arm shafts.

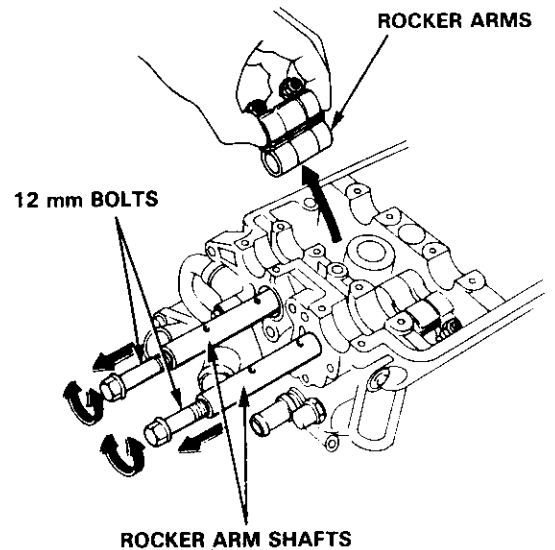

Rocker Arms

Disassembly/Reassembly

CAUTION: After installing the rocker shaft orifice, make sure that the orifice is correctly installed in the hole of rocker shaft by trying to turn the rocker shaft. If the orifice is in place, it should not turn.

NOTE:

- Identify parts as they are removed to ensure reinstallation in original locations.
- Inspect rocker shafts and rocker arms (see page 6-73).
- Rocker arms must be installed in the same position if reused.
- Clean the rocker shaft orifices when installing.

 Prior to reinstalling, clean all the parts in solvent, dry them, and apply lubricant to any contact surfaces.

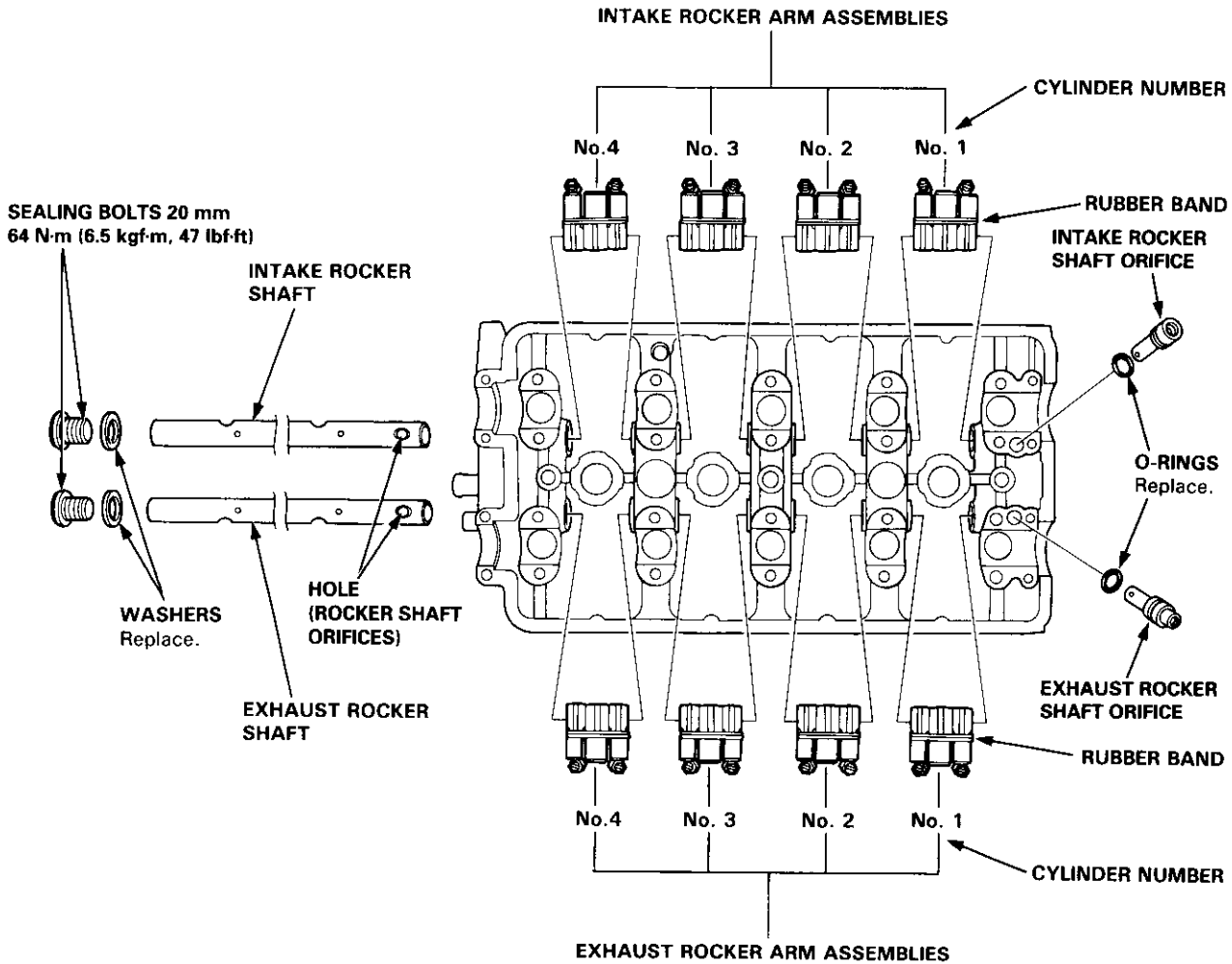

Rocker Arms and Lost Motion Assemblies



Inspection

NOTE: When reassembling the primary rocker arm, carefully apply air pressure to the oil passage of the rocker arm.

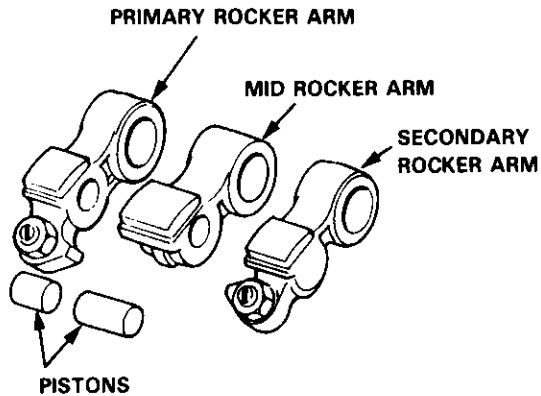

1. Inspect each rocker arm piston. Push it manually.

— If it does not move smoothly, replace the rocker arm assembly.

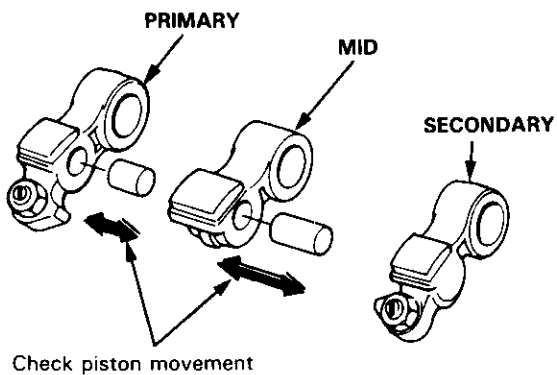

NOTE:

- Apply oil to the pistons when reassembling.
- Bundle the rocker arms with a rubber band to keep them together as a set.

2. Remove the lost motion assembly from the cylinder head and inspect it. Test it by pushing the plunger with your finger.

— If the lost motion assembly does not move smoothly, replace it.

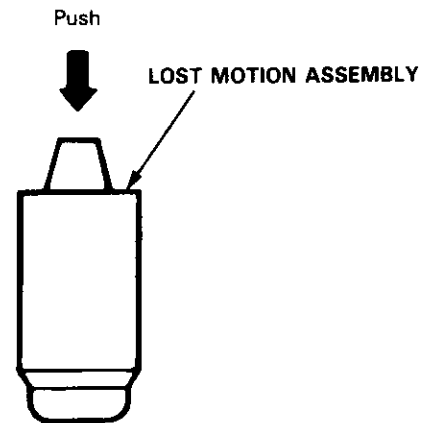

Rocker Arms and Shafts

Clearance Inspection

Measure both the intake rocker shaft and exhaust rocker shaft.

1. Measure diameter of shaft at the first rocker location.

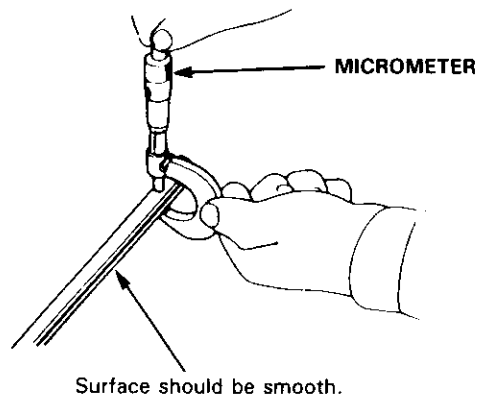

2. Zero gauge to shaft diameter.

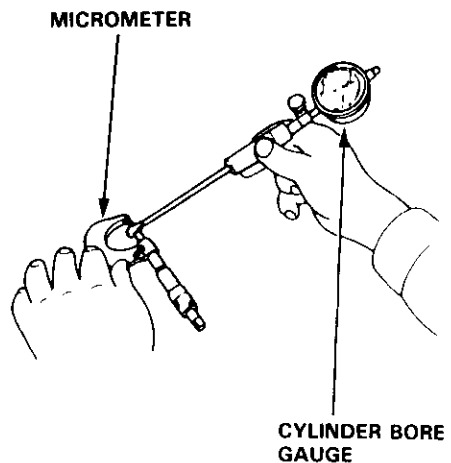

3. Measure the inside diameter of each rocker arm and check for out-of-round condition.

Rocker Arm-to-Shaft Clearance:

Intake and Exhaust

Standard (New): 0.025 – 0.052 mm
(0.0010 – 0.0020 in)

Service Limit: 0.08 mm (0.003 in)

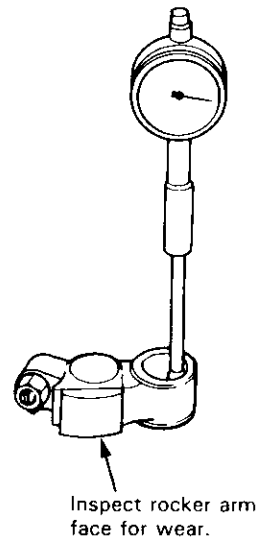

Repeat for all rockers.

— If over limit, replace rocker shaft and all overtolerance rocker arms.

NOTE: If any rocker arm needs replacement, replace all three rocker arms in that set (primary, mid, and secondary).



Inspection

NOTE:

- Do not rotate the camshaft during inspection.
- Remove the rocker arms and rocker shafts.

1. Put the camshafts and camshaft holders on the cylinder head, and then tighten the bolts to the specified torque.

Specified Torque:

- ① - ⑩: 8 mm bolts 27 N·m (2.8 kgf·m, 20 lbf·ft)
Apply engine oil to the threads.
- ⑪ - ⑫: 6 mm bolts 9.8 N·m (1.0 kgf·m, 7.2 lbf·ft)

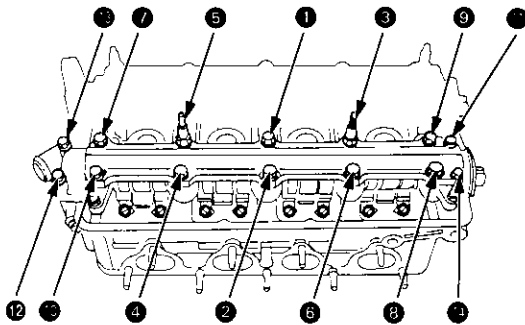
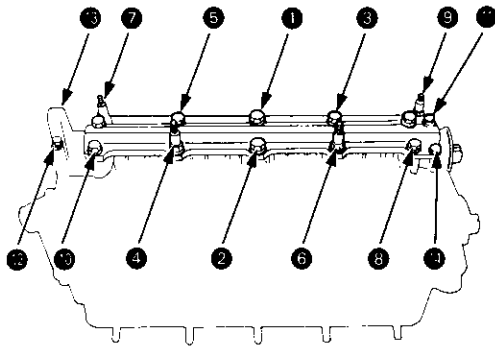

2. Seat the camshaft by pushing it toward the distributor end of the cylinder head.
3. Zero the dial indicator against the end of the distributor drive, then push the camshaft back and forth and read the end play.

Camshaft End Play:

- Standard (New): 0.05 - 0.15 mm
(0.002 - 0.006 in)
- Service limit: 0.5 mm (0.02 in)

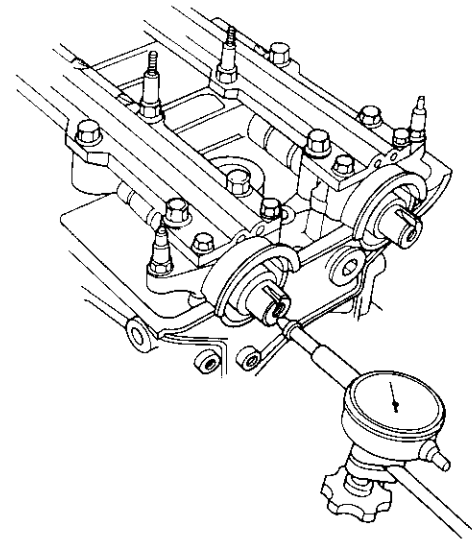

4. Remove the bolts, then remove the camshaft holders from the cylinder head.
 - Lift the camshaft out of the cylinder head, wipe clean, then inspect the lift ramps. Replace the camshaft if lobes are pitted, scored, or excessively worn.
 - Clean the camshaft bearing surfaces in the cylinder head, then set the camshaft back in place.
 - Insert a plastigage strip across each journal.
5. Put the camshaft on the cylinder head, then install the camshaft holders, and then tighten the bolts to the specified torque as shown in the left column on this page.
6. Remove the camshaft holders, then measure the widest portion of the plastigage on each journal.

- Camshaft-to-Holder Oil Clearance:**
- Standard (New): 0.050 - 0.089 mm
(0.002 - 0.004 in)
- Service Limit: 0.15 mm (0.006 in)

PLASTIGAGE STRIP

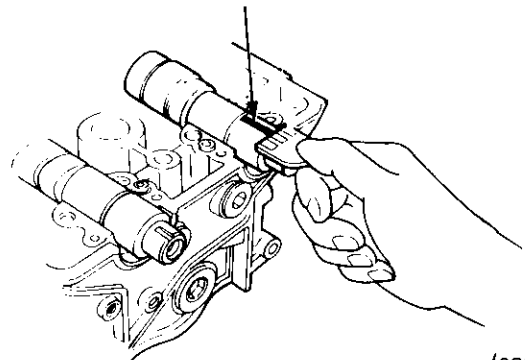

(cont'd)

Camshafts

Inspection (cont'd)

7. If the camshaft-to-holder oil clearance is out of tolerance:

- And the camshaft has already been replaced, you must replace the cylinder head.
- If the camshaft has not been replaced, first check the total runout with the camshaft supported on V-blocks.

Camshaft Total Runout:

Standard (New): 0.03 mm (0.001 in) max.

Service Limit: 0.04 mm (0.002 in)

Rotate camshaft while measuring

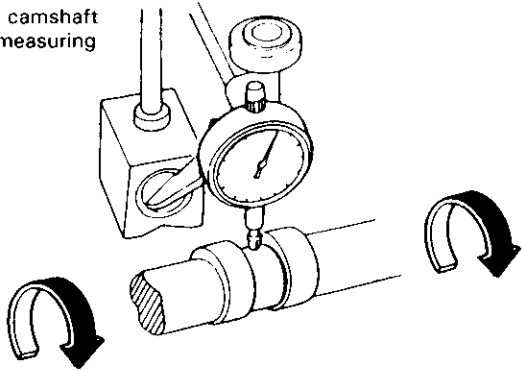

- If the total runout of the camshaft is within tolerance, replace the cylinder head.
- If the total runout is out of tolerance, replace the camshaft and recheck the camshaft-to-holder oil clearance. If the oil clearance is still out of tolerance, replace the cylinder head.

8. Check the cam lobe height.

Cam lobe height standard (New):

	INTAKE	EXHAUST
PRIMARY	33.088 mm (1.3027 in)	32.785 mm (1.2907 in)
MID	36.267 mm (1.4278 in)	35.720 mm (1.4063 in)
SECONDARY	34.978 mm (1.3771 in)	34.691 mm (1.3658 in)

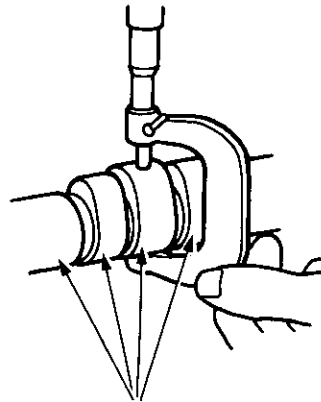

Check this area for wear.

Cam Position

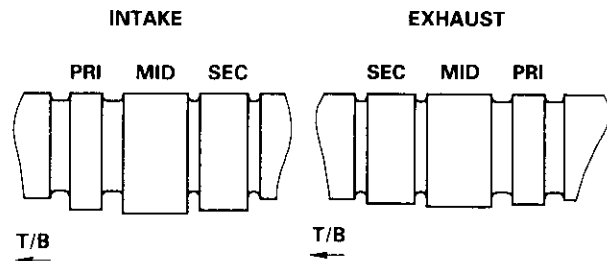

T/B: TIMING BELT
 PRI: PRIMARY
 MID: MID
 SEC: SECONDARY

Valves, Valve Springs and Valve Seals



Removal

NOTE: Identify valves and valve springs as they are removed so that each item can be reinstalled in its original position.

1. Using an appropriate-sized socket and plastic mallet, lightly tap the valve retainer to loosen the valve keepers.

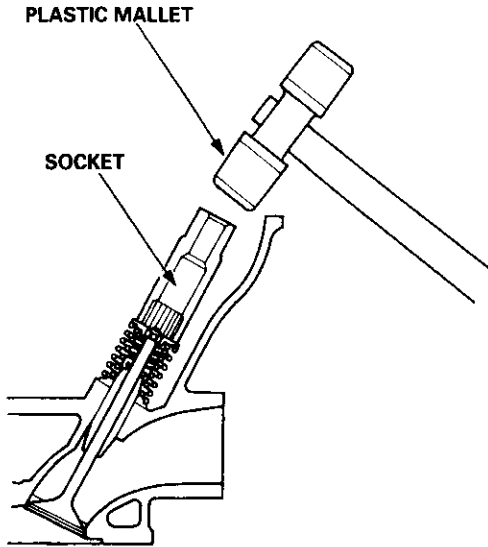

2. Install the valve spring compressor. Compress the spring and remove the valve keepers.

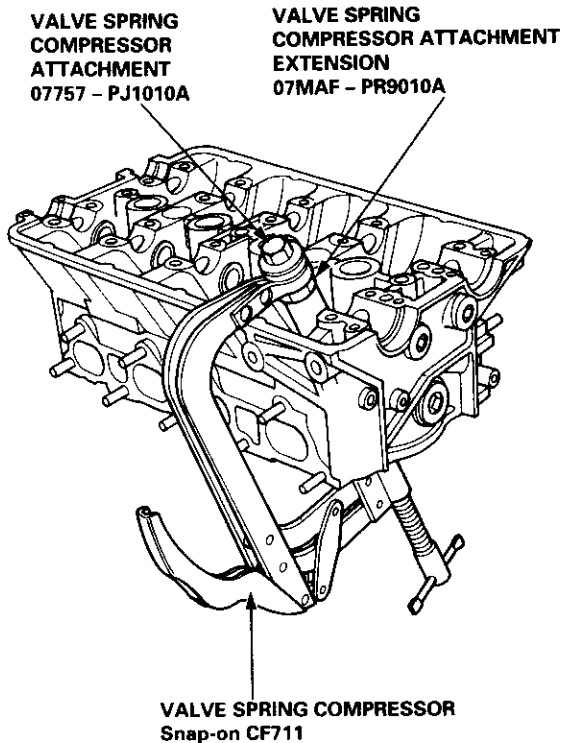

3. Install the valve guide seal remover.

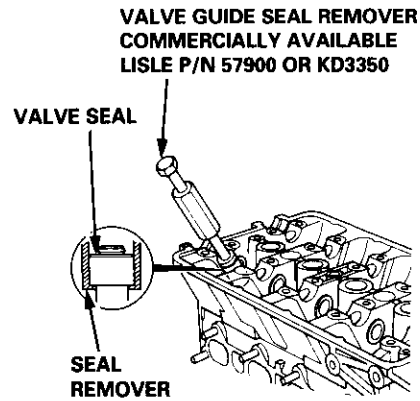

4. Remove the valve guide seal.

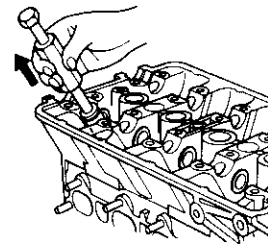

Valve Dimensions

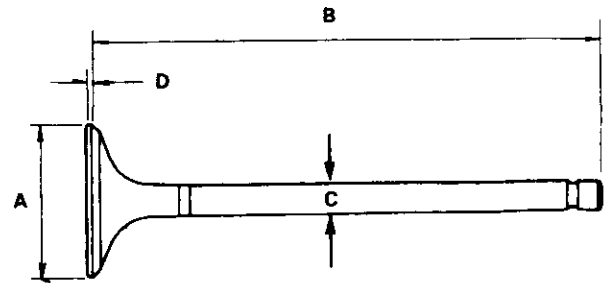

Intake Valve

- A Standard (New): 32.90 - 33.10 mm (1.295 - 1.303 in)
 B Standard (New): 101.00 - 101.30 mm (3.976 - 3.988 in)
 C Standard (New): 5.475 - 5.485 mm (0.2156 - 0.2159 in)
 C Service Limit: 5.445 (0.2144 in)
 D Standard (New): 1.05 - 1.35 mm (0.041 - 0.053 in)
 D Service Limit: 0.85 mm (0.033 in)

Exhaust Valve

- A Standard (New): 27.90 - 28.10 mm (1.098 - 1.106 in)
 B Standard (New): 100.60 - 100.90 mm (3.961 - 3.972 in)
 C Standard (New): 5.450 - 5.460 mm (0.2146 - 0.2150 in)
 C Service Limit: 5.420 (0.2134 in)
 D Standard (New): 1.65 - 1.95 mm (0.065 - 0.077 in)
 D Service Limit: 1.45 mm (0.057 in)

Valve Seats

Reconditioning

1. Renew the valve seats in the cylinder head with a valve seat cutter.

NOTE: If any guides are worn (see page 6-79), replace them (see page 6-80) before cutting the valve seats.

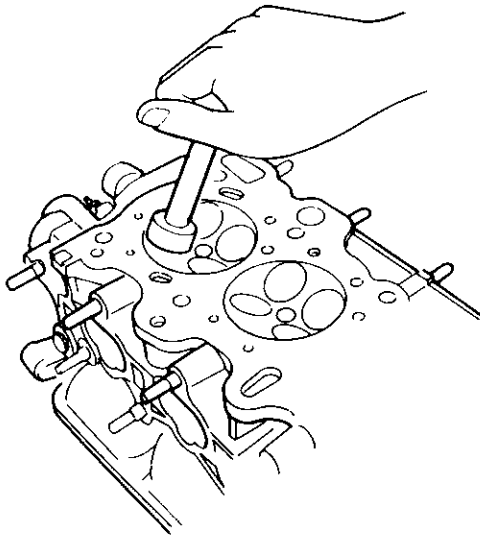

2. Carefully cut a 45° seat, removing only enough material to ensure a smooth and concentric seat.
3. Bevel the upper edge of the seat with the 30° cutter and the lower edge of the seat with the 60° cutter. Check width of seat and adjust accordingly.
4. Make one more very light pass with the 45° cutter to remove any possible burrs caused by the other cutters.

Valve Seat Width:

Standard (New): 1.25 – 1.55 mm (0.049 – 0.061 in)

Service Limit: 2.0 mm (0.08 in)

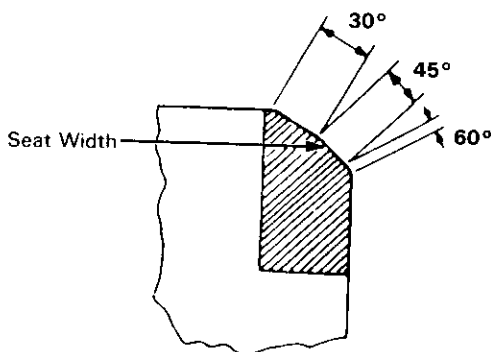

5. After resurfacing the seat, inspect for even valve seating: Apply Prussian Blue Compound to the valve face, and insert the valve in its original location in the head, then lift it and snap it closed against the seat several times.

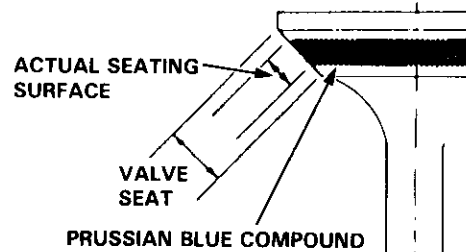

6. The actual valve seating surface, as shown by the blue compound, should be centered on the seat.
 - If it is too high (closer to the valve stem), you must make a second cut with the 60° cutter to move it down, then one more cut with the 45° cutter to restore seat width.
 - If it is too low (closer to the valve edge), you must make a second cut with the 30° cutter to move it up, then one more cut with the 45° cutter to restore seat width.

NOTE: The final cut should always be made with the 45° cutter.

7. Insert the intake and exhaust valves in the head and measure valve stem installed height.

Intake Valve Stem Installed Height:

Standard (New): 37.465 – 37.935 mm

(1.4750 – 1.4935 in)

Service Limit: 38.185 mm (1.5033 in)

Exhaust Valve Stem Installed Height:

Standard (New): 37.165 – 37.635 mm

(1.4632 – 1.4817 in)

Service Limit: 37.885 (1.4915 in)

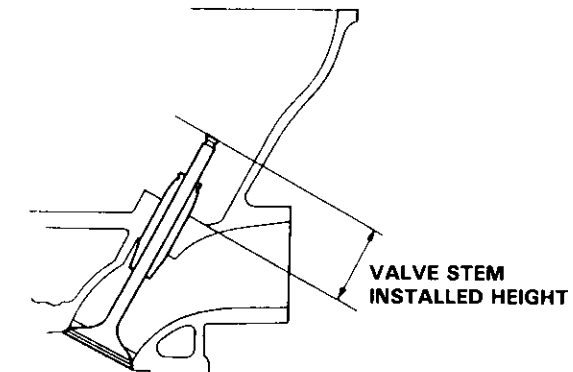

8. If valve stem installed height is over the service limit, replace the valve and recheck. If it is still over the service limit, replace the cylinder head; the valve seat in the head is too deep.



Warpage

NOTE: If camshaft-to-holder oil clearances (see page 6-75) are not within specification, the head cannot be resurfaced.

If camshaft-to-holder oil clearances are within specifications, check the head for warpage.

- If warpage is less than 0.05 mm (0.002 in) cylinder head resurfacing is not required.
- If warpage is between 0.05 mm (0.002 in) and 0.2 mm (0.008 in), resurface cylinder head.
- Maximum resurface limit is 0.2 mm (0.008 in) based on a height of 142 mm (5.59 in).

PRECISION STRAIGHT EDGE

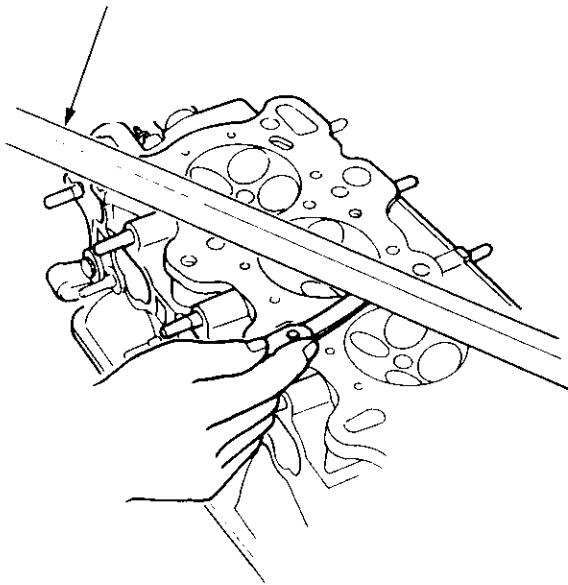

Measure along edges, and three ways across center.

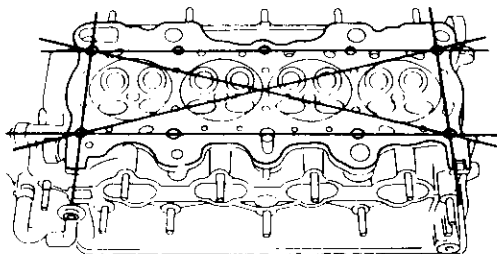

Cylinder Head Height:
Standard (New): 141.95 – 142.05 mm
 (5.589 – 5.593 in)

Valve Movement

Measure the guide-to-stem clearance with a dial indicator while rocking the stem in the direction of normal thrust (wobble method).

Intake Valve Stem-to-Guide Clearance:

Standard (New): 0.05 – 0.11 mm
 (0.0020 – 0.0043 in)

Service Limit: 0.15 mm (0.0059 in)

Exhaust Valve Stem-to-Guide Clearance:

Standard (New): 0.10 – 0.16 mm
 (0.0039 – 0.0063 in)

Service Limit: 0.24 (0.0094 in)

Valve extended 10 mm out from seat.

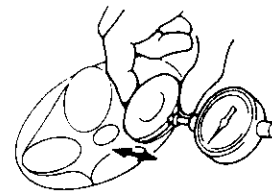

- If the measurement exceeds the service limit, recheck using a new valve.
- If the measurement is now within the service limit, reassemble using the new valve.
- If the measurement still exceeds the limit, recheck using the alternate method below, then replace the valve and guide, if necessary.

NOTE: An alternate method of checking guide to stem clearance is to subtract the O.D. of the valve stem, measured with a micrometer, from the I.D. of the valve guide, measured with an inside micrometer or ball gauge.

Take the measurements in three places along the valve stem and three places inside the valve guide.

The difference between the largest guide measurement and the smallest stem measurement should not exceed the service limit.

Intake Valve Stem-to-Guide Clearance:

Standard (New): 0.025 – 0.055 mm
 (0.0010 – 0.0022 in)

Service Limit: 0.08 mm (0.003 in)

Exhaust Valve Stem-to Guide Clearance:

Standard (New): 0.050 – 0.080 mm
 (0.0020 – 0.0031 in)

Service Limit: 0.11 mm (0.004 in)

Valve Guides

Replacement

1. As illustrated below, use a commercially available air-impact valve guide driver attachment modified to fit the diameter of the valve guides. In most cases, the same procedure can be done using the special tool and a conventional hammer.

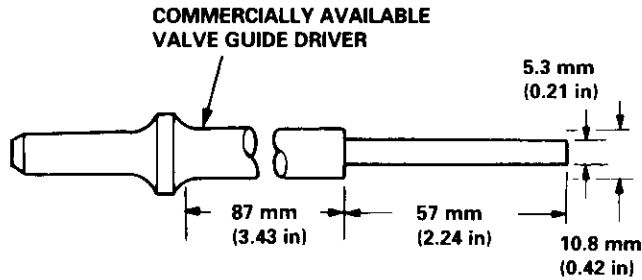

or
VALVE GUIDE DRIVER,
5.5 mm
07742 - 0010100

2. Select the proper replacement guides and chill them in the freezer section of a refrigerator for about an hour.
3. Use a hot plate or oven to evenly heat the cylinder head to 300°F (150°C). Monitor the temperature with a cooking thermometer.

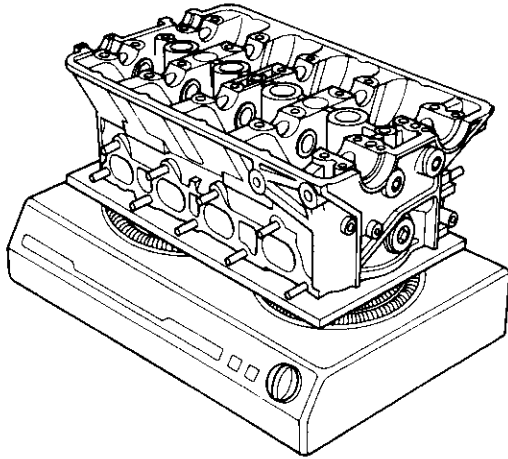

CAUTION:

- Do not use a torch; it may warp the head.
- Do not get the head hotter than 300°F (150°C); excessive heat may loosen the valve seats.
- To avoid burns, use heavy gloves when handling the heated cylinder head.

4. Working from the camshaft side, use the driver and an air hammer to drive the guide about 2 mm (0.1 in) towards the combustion chamber. This will knock off some of the carbon and make removal easier.

CAUTION:

- Always wear safety goggles or a face shield when driving valve guides.
- Hold the air hammer directly in line with the valve guide to prevent damaging the driver.

5. Turn the head over and drive the guide out toward the camshaft side of the head.

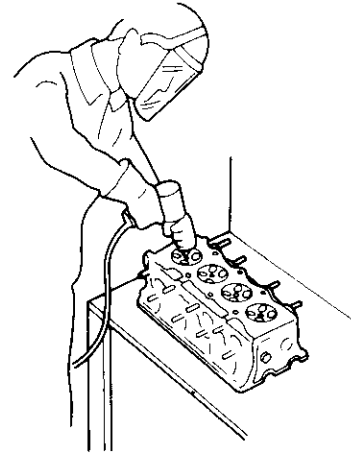

VALVE GUIDE DRIVER,
5.5 mm
07742 - 0010100

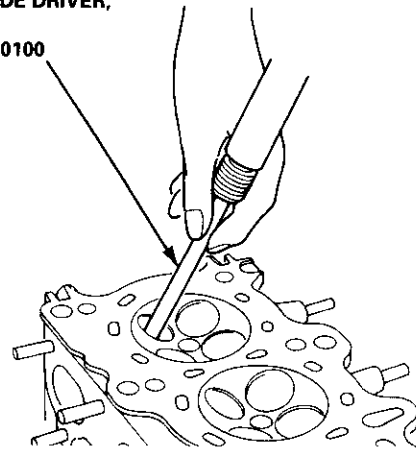

If a valve guide still won't move, drill it out with a 8.0 mm (5/16 in) bit, then try again.

CAUTION: Drill guides only in extreme cases; you could damage the cylinder head if the guide breaks.

6. Remove the new guide(s) from the freezer, one at a time, as you need them.



7. Apply a thin coat of clean engine oil to the outside of the new valve guide. Install the guide from the camshaft side of the head; use the special tool to drive the guide in to the specified installed height. If you have all 16 guides to do, you may have to reheat the head.

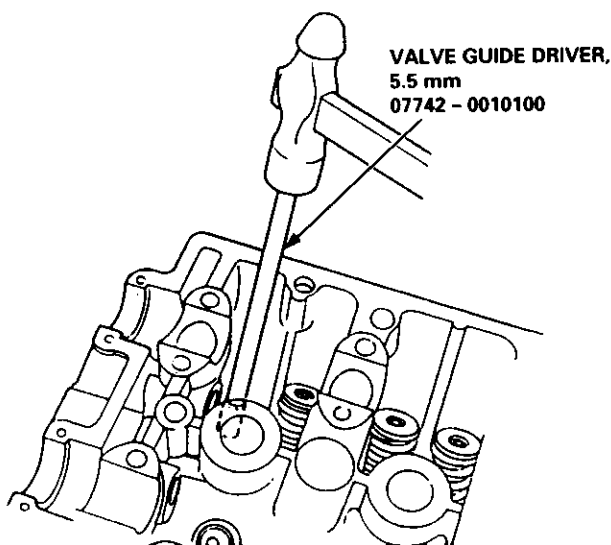

Valve Guide Installed Height:

Intake: 12.55 - 13.05 mm (0.494 - 0.514 in)

Exhaust: 12.55 - 13.05 mm (0.494 - 0.514 in)

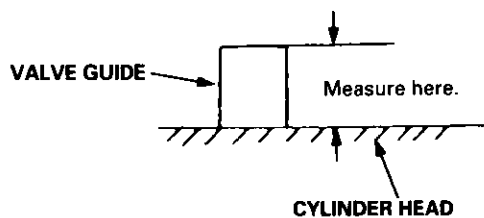

Reaming

NOTE: For new valve guides only.

1. Coat both reamer and valve guide with cutting oil.
 2. Rotate the reamer clockwise the full length of the valve guide bore.
 3. Continue to rotate the reamer clockwise while removing it from the bore.
 4. Thoroughly wash the guide in detergent and water to remove any cutting residue.
 5. Check clearance with a valve (see page 6-73).
- Verify that the valve slides in the intake and exhaust valve guides without exerting pressure.

REAMER HANDLE

Turn reamer in clockwise direction only.

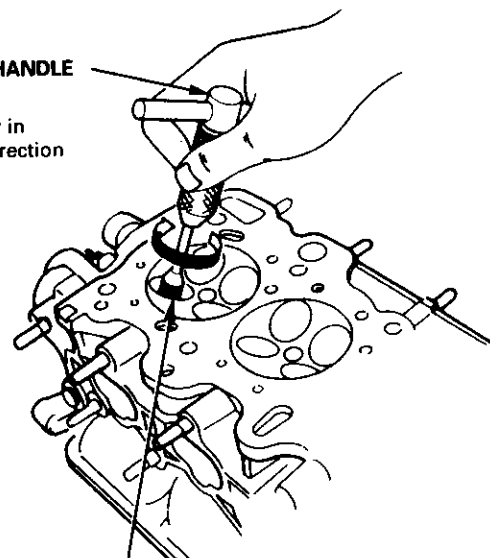

**VALVE GUIDE REAMER, 5.5 mm
07HAH - PJ7010B**

Valves

Installation

1. Coat the valve stems with oil. Insert the valves into the valve guides.

NOTE: Check that the valves move up and down smoothly.

2. Install the spring seats on the cylinder head.
3. Install the valve seals using the special tool.

NOTE: Exhaust and intake valve seals are not interchangeable.

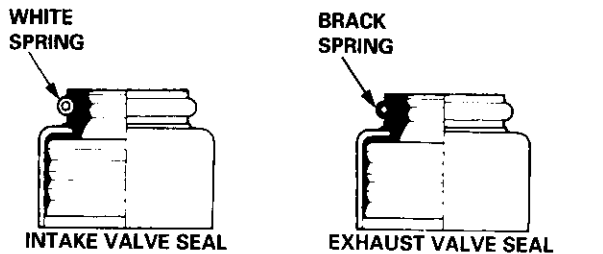

VALVE GUIDE SEAL INSTALLER
KD-2899 (Commercially available)
NOTE: Use small ID
end of tool.

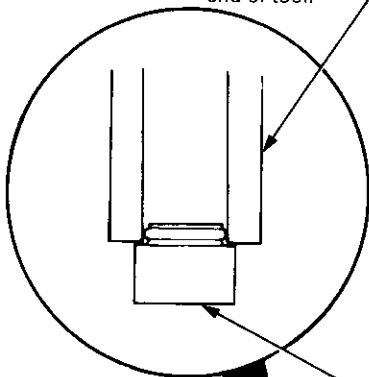

VALVE SEAL
Replace.

VALVE GUIDE SEAL INSTALLER
KD-2899
NOTE: Use small ID
end of tool.

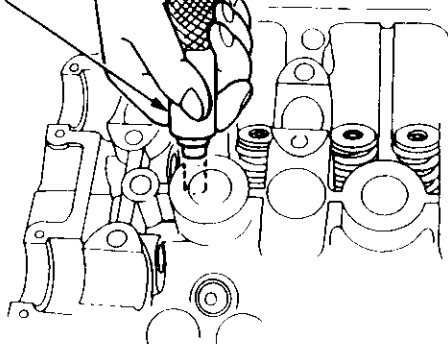

4. Install the valve spring and valve retainer, then install the valve spring compressor. Compress the spring, and install the valve keepers.

NOTE: Place the end of the valve spring with closely wound coils toward the cylinder head.

VALVE SPRING
COMPRESSOR
ATTACHMENT
07757 - PJ1010A

VALVE SPRING
COMPRESSOR ATTACHMENT
EXTENSION
07MAF - PR9010A

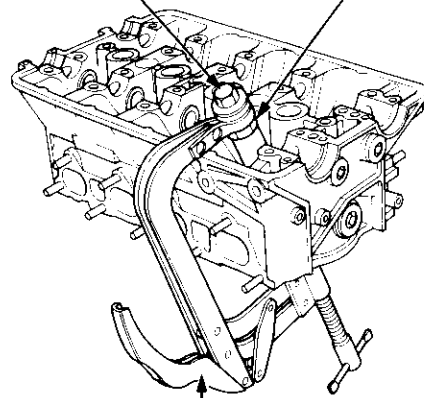

VALVE SPRING COMPRESSOR
(Commercially available)
Snap-on CF711 or KD-383
with #32JAWS

5. Lightly tap the end of each valve stem two or three times with the wooden handle of a hammer to ensure proper seating of the valve and valve keepers.

NOTE: Tap the valve stem only along its axis so you do not bend the stem.

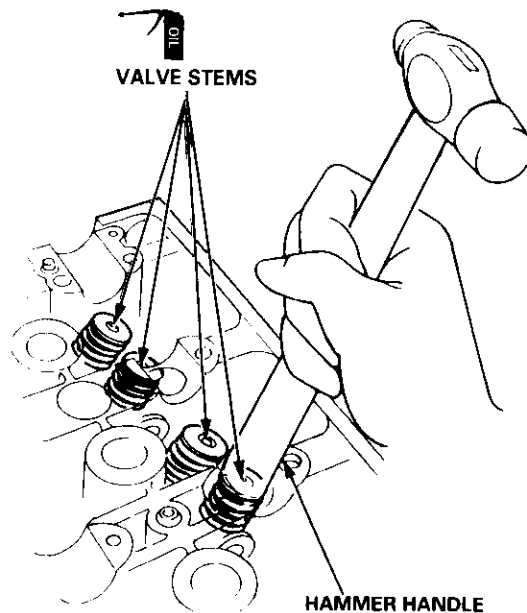



Rocker Arms

Installation

1. Install the rocker arms in the reverse order of removal:
 - Valve adjusting locknuts should be loosened and the adjusting screw, backed off before installation.
 - The component parts must be reinstalled in the original locations.
2. Install the lost motion assemblies.
3. Install the rocker arms while inserting the rocker arm shaft into the cylinder head.

NOTE: Remove the rubber band after installing the rocker arms.

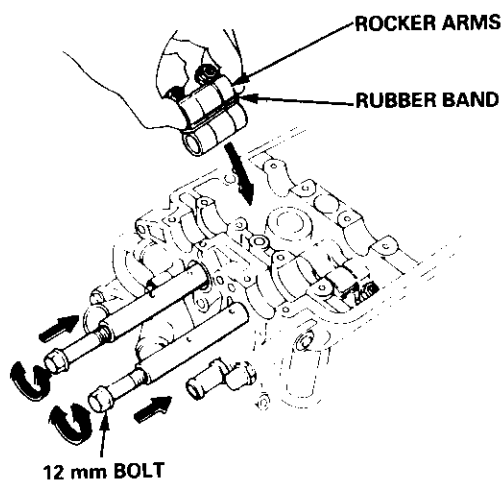

4. Clean and install the rocker shaft orifices with new O-rings. If the holes in the rocker arm shaft and cylinder head are not in line with each other, screw a 12 mm bolt into the rocker arm shaft and rotate the shaft.

NOTE: The shapes of the rocker shaft orifices for the intake and exhaust are different. The orifice must be installed in the proper locations.

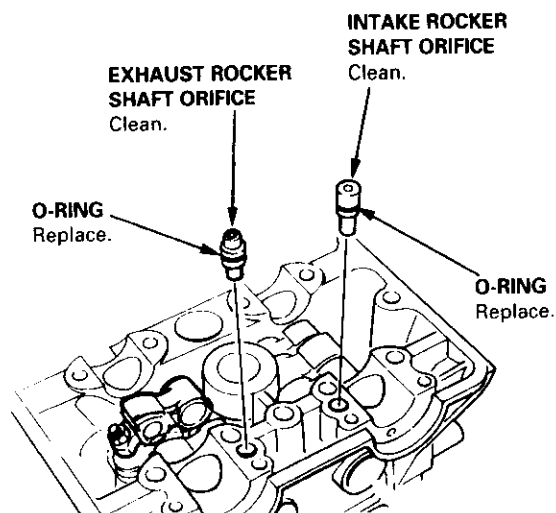

Cylinder Head

Installation

Install the cylinder head in the reverse order of removal:

NOTE:

- Always use a new head and manifold gasket.
- The cylinder head gasket is a metal gasket. Take care not to bend it.
- Rotate the crankshaft, set the No. 1 piston at TDC (see page 6-63).
- Do not use the middle cover and lower cover for storing removed items.
- Clean the middle cover and lower cover before installation.
- Replace any washers that are damaged or deteriorated.

1. Install the cylinder head gasket, dowel pins and the head oil control orifice on the cylinder head.

NOTE: Clean the oil control orifice when installing.

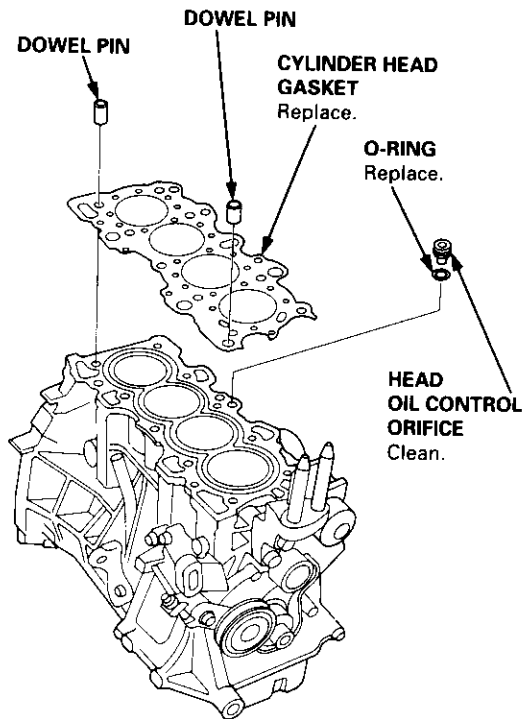

2. Tighten the cylinder head bolts in two steps. In the first step, tighten all bolts in sequence to about 29 N·m (3.0 kgf·m, 22 lbf·ft). In the final step, tighten in the same sequence to 83 N·m (8.5 kgf·m, 61 lbf·ft).

NOTE:

- Apply clean engine oil to the bolt threads and under the bolt head.
- We recommend using a beam-type torque wrench. When using a preset-type torque wrench, be sure to tighten slowly and not to overtighten.
- If a bolt makes any noise while you are torquing it, loosen the bolt, and retighten it from the 1st step.

CYLINDER HEAD BOLT TORQUE SEQUENCE

11 x 1.5 mm
83 N·m (8.5 kgf·m, 61 lbf·ft)

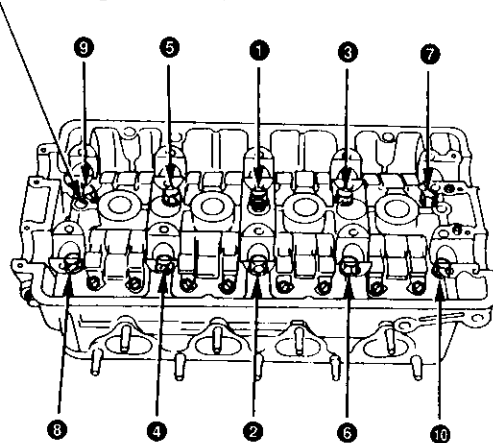

3. Install the intake manifold and tighten the nuts in a crisscross pattern in two or three steps, beginning with the inner nuts.
 - Always use a new intake manifold gasket.
4. Install the exhaust manifold and tighten the new self-locking nuts in a crisscross pattern in two or three steps, beginning with the inner nuts.
 - Always use a new exhaust manifold gasket.



5. Install the camshafts and camshaft oil seals.

NOTE:

- Install the camshafts with the keyway facing up.
- Install the oil seal with the spring side facing in.
- The oil seal housing surface should be dry.
- Set the O-ring and dowel pin in the oil passage of the No. 3 camshaft holder.

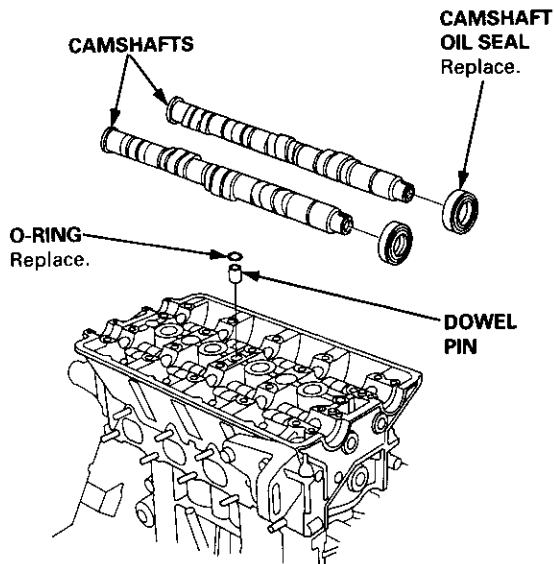

6. Apply liquid gasket (P/N 08718 - 0001 or 08718 - 0003) to the head mating surfaces of the No. 1 and No. 5 camshaft holders on both the intake and exhaust side.

NOTE: Clean and dry the cylinder head mating surfaces before applying liquid gasket.

— Apply liquid gasket to the shaded areas.

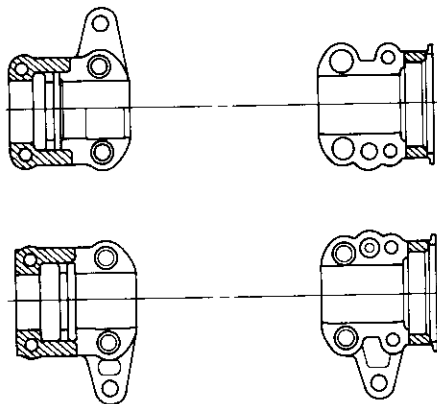

No. 5

No. 1

7. Install the camshaft holders and camshaft holder plate.

NOTE: The arrows marked on the camshaft holders should point to the timing belt.

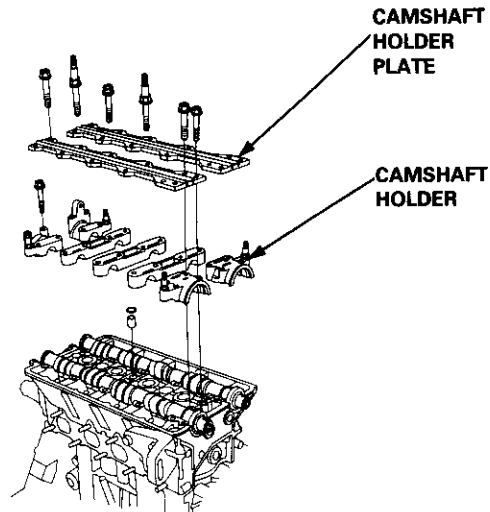

8. Tighten each bolt two turns at a time in the sequence shown below.

NOTE: Wipe off the excess liquid gasket from the No. 1 and No. 5 camshaft holders with a shop towel.

① - ⑩: 8 x 1.25 mm 27 N·m (2.8 kgf·m, 20 lbf·ft)

Apply engine oil to the threads.

⑪ - ⑬: 6 x 1.0 mm 9.8 N·m (1.0 kgf·m, 7.2 lbf·ft)

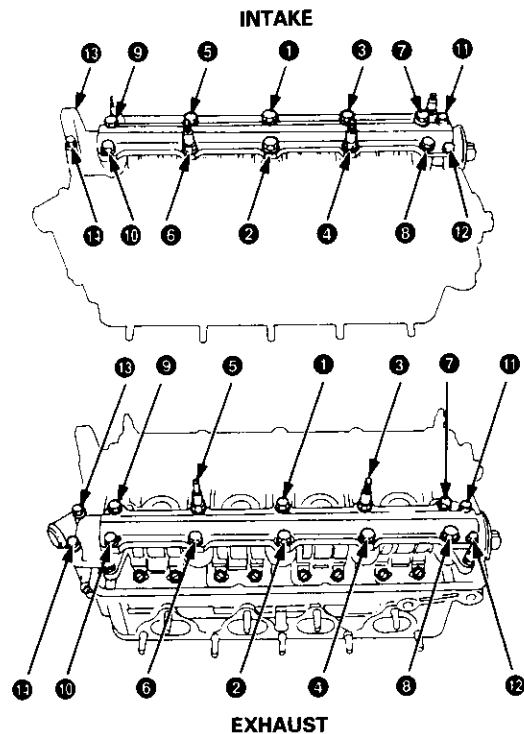

9. Install the back cover and camshaft pulleys.

(cont'd)

Cylinder Head

Installation (cont'd)

10. Align the marks on the cylinder head plug to the cylinder head upper surface, then install the cylinder head plug in the cylinder head.

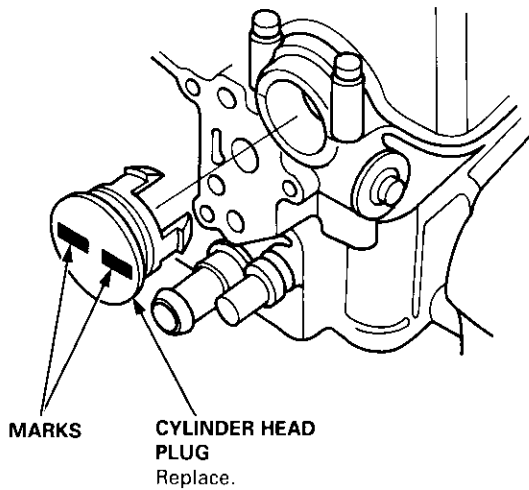

11. Install the timing belt (see page 6-63).
12. Adjust the valve clearance (see page 6-61).
13. Install the head cover gasket in the groove of the cylinder head cover. Seat the recesses for the camshaft first, then work it into the groove around the outside edges.

NOTE:

- Before installing the head cover gasket, thoroughly clean the head cover gasket and the groove.
- When installing, make sure the head cover gasket is seated securely in the corners of the recesses with no gap.

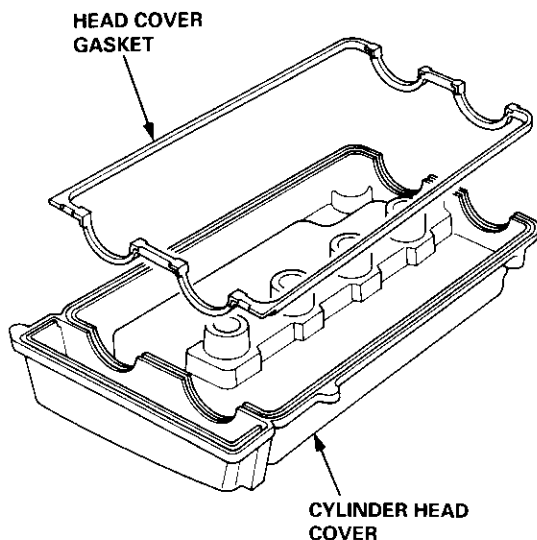

14. Apply liquid gasket to the head cover gasket at the eight corners of the recesses.

NOTE:

- Use liquid gasket, Part No. 08718 - 0001 or 08718 - 0003.
- Check that the mating surfaces are clean and dry before applying liquid gasket.
- Do not install the parts if five minutes or more have elapsed since applying liquid gasket. Instead, reapply liquid gasket after removing old residue.
- After assembly, wait at least 30 minutes before filling the engine with oil.

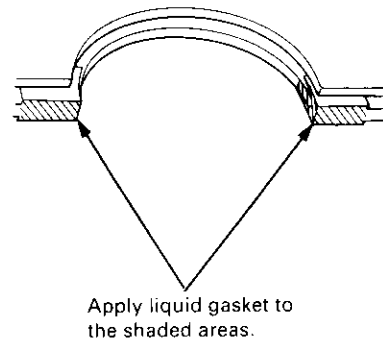



15. When installing the cylinder head cover, hold the head cover gasket in the groove by placing your fingers on the camshaft holder contacting surfaces (top of the semicircles). Once the cylinder head cover is on the cylinder head, slide the cover slightly back and forth to seat the head cover gasket.

NOTE:

- Before installing the cylinder head cover, clean the cylinder head contacting surfaces using a shop towel.
- Do not touch the parts where liquid gasket was applied.
- Replace any washer that is damaged or deteriorated.

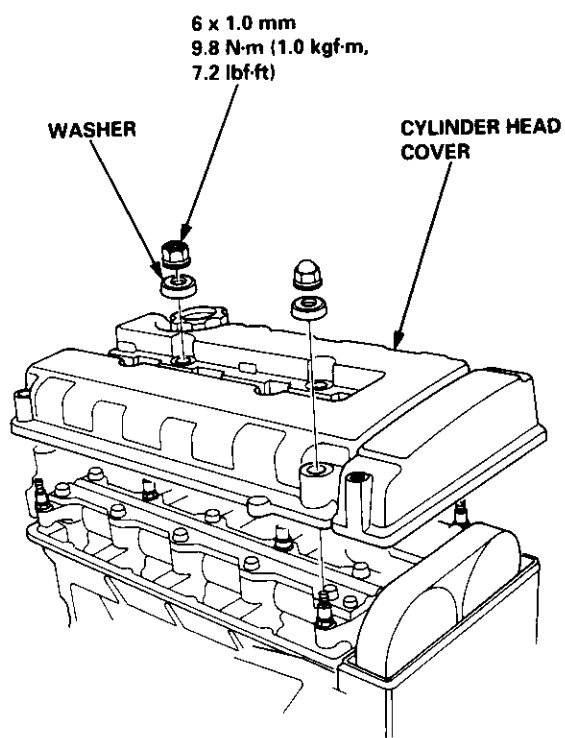

16. Tighten the nuts in two or three steps. In the final step, tighten all nuts, in sequence, to 9.8 N·m (1.0 kgf·m, 7.2 lbf·ft).

NOTE: After assembly, wait at least 30 minutes before filling the engine with oil.

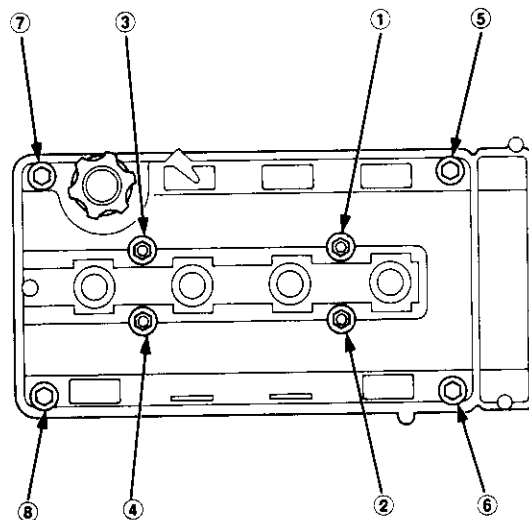

17. After installing, check that all tubes, hoses and connectors are installed correctly.

Engine Block

Special Tools	7-2
Illustrated Index	7-3
Flywheel and Drive Plate	
Replacement	7-7
Connecting Rod and Crankshaft	
End Play	7-8
Main Bearings	
Clearance	7-9
Selection	7-10
Connecting Rod Bearings	
Clearance	7-11
Selection	7-11
Pistons and Crankshaft	
Removal	7-12
Crankshaft	
Inspection	7-14
Pistons	
Inspection	7-15
Installation	7-23

Cylinder Block	
Inspection	7-16
Bore Honing	7-17
Piston Pins	
Removal	7-17
Installation	7-18
Inspection	7-19
Connecting Rods	
Selection	7-18
Piston Rings	
End Gap	7-20
Replacement	7-20
Ring-to-Groove Clearance	7-21
Alignment	7-21
Crankshaft Oil Seal	
Installation	7-22
Crankshaft	
Installation	7-23
Oil Pan	
Installation	7-26
Oil Seals	
Installation	7-29



Special Tools

Ref. No.	Tool Number	Description	Qty	Page Reference
①	07LAB - PV00100	Ring Gear Holder	1	7-7
②	07749 - 0010000	Driver	1	7-22, 29
③	07947 - SB00200	Seal Driver	1	7-29
④	07948 - SB00101	Driver Attachment	1	7-22, 29
⑤	07973 - PE00200	Pilot Collar	1	7-17, 18
⑥	07973 - PE00310	Piston Pin Driver Shaft	1	7-17, 18
⑦	07973 - PE00320	Piston Pin Driver Head	1	7-17, 18
⑧	07973 - PE00400	Piston Pin Base Insert	1	7-17, 18
⑨	07973 - SB00100	Piston Base Head	1	7-17, 18
⑩	07973 - 6570500	Piston Base	1	7-17, 18
⑪	07973 - 6570600	Piston Base Spring	1	7-17, 18

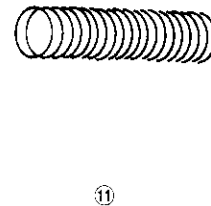
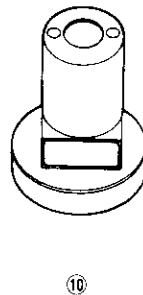
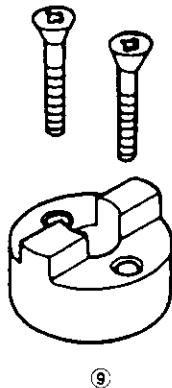
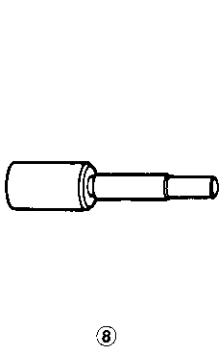
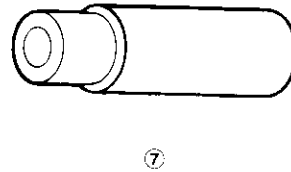
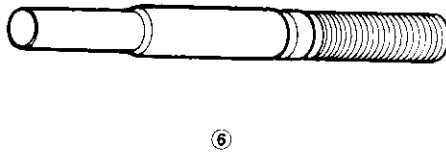
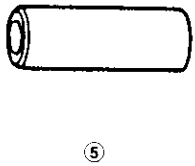
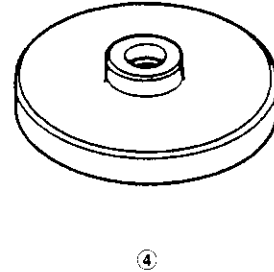
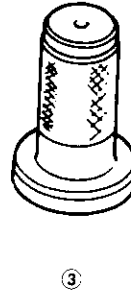
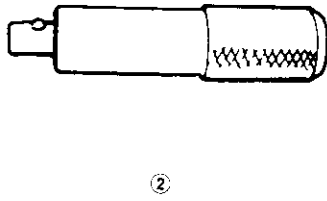
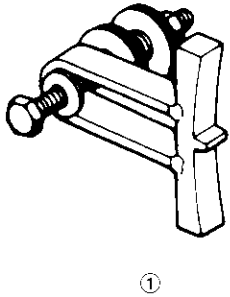

Illustrated Index



 Lubricate all internal parts with engine oil during reassembly.

NOTE:

- Apply liquid gasket to the mating surfaces of the right side cover and oil pump case before installing them.
- Use liquid gasket, part No. 08718 - 0001 or 08718 - 0003.
- Clean the oil pan gasket mating surfaces before installing the oil pan.

B16A2 engine:

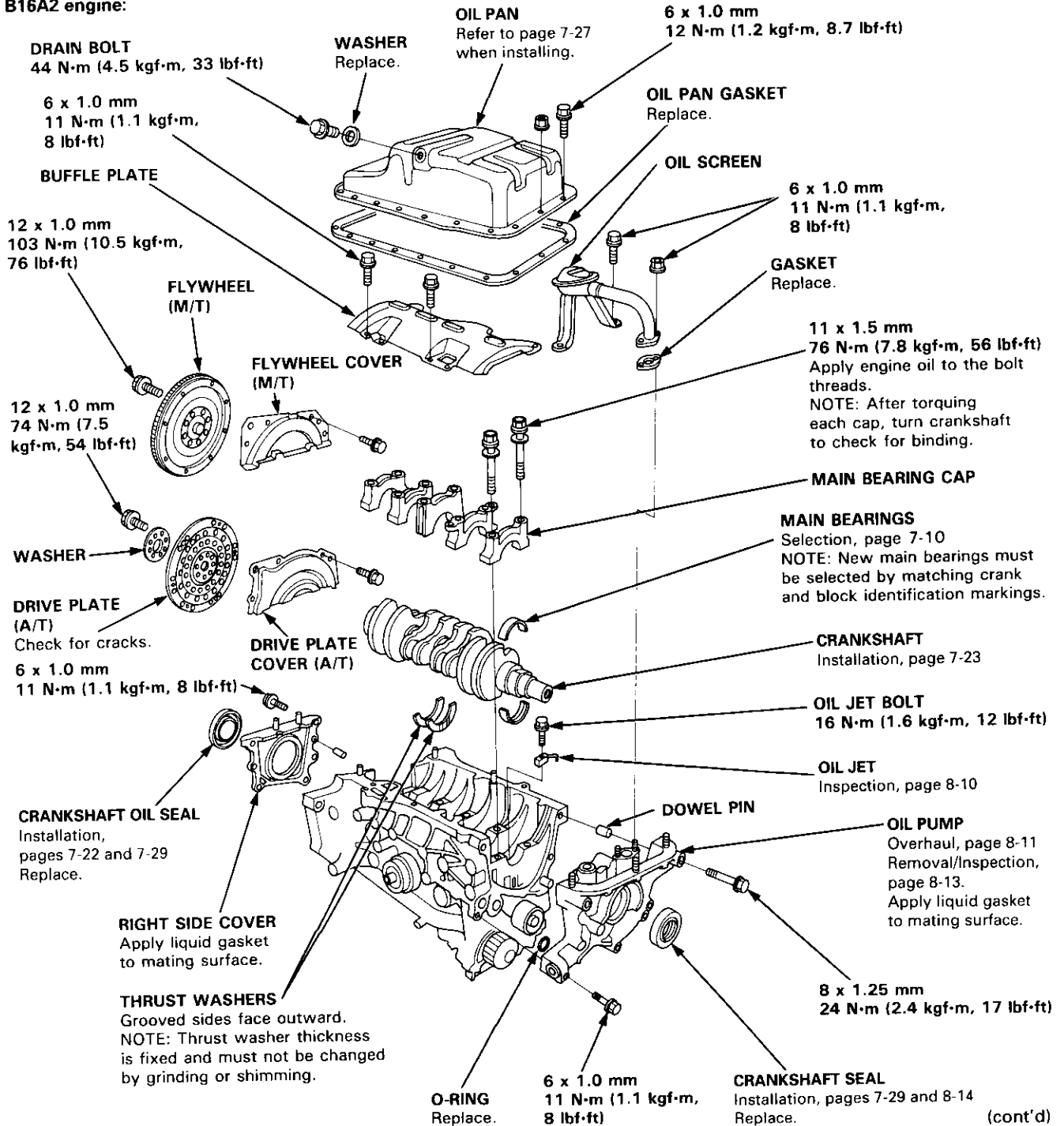

(cont'd)



D16Y5, D16Y8 engines:

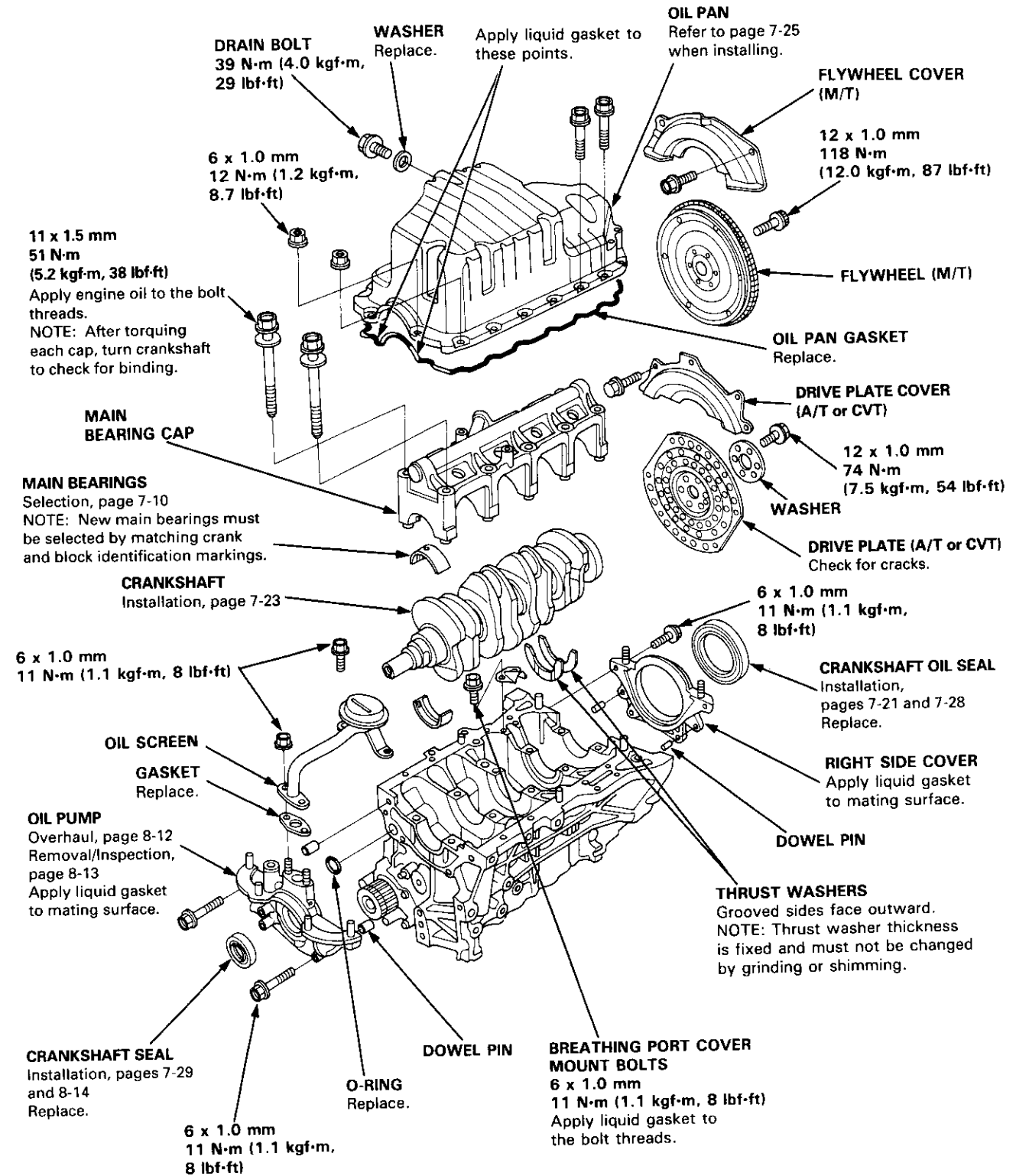

(cont'd)

Illustrated Index

(cont'd)

NOTE: New rod bearings must be selected by matching connecting rod assembly and crankshaft identification markings (see page 7-11).

 Lubricate all internal parts with engine oil during reassembly.

PISTON INSTALLATION DIRECTION:

EXHAUST

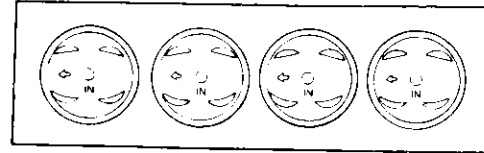

INTAKE

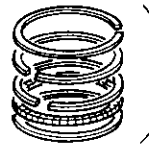

PISTON RINGS

Replacement, page 7-20
Measurement, pages 7-20 and 7-21
Alignment, page 7-21

PISTON PIN

Removal, page 7-17
Installation, page 7-18
Inspection, page 7-19



PISTON

Inspection, page 7-15
NOTE: Before removing the piston, inspect the top of the cylinder bore for carbon build-up or ridge. Remove ridge if necessary, page 7-13

CONNECTING ROD

End play, page 7-8
Selection, page 7-18



ENGINE BLOCK

Cylinder bore inspection, page 7-16
Warping inspection, page 7-16
Cylinder bore honing, page 7-17

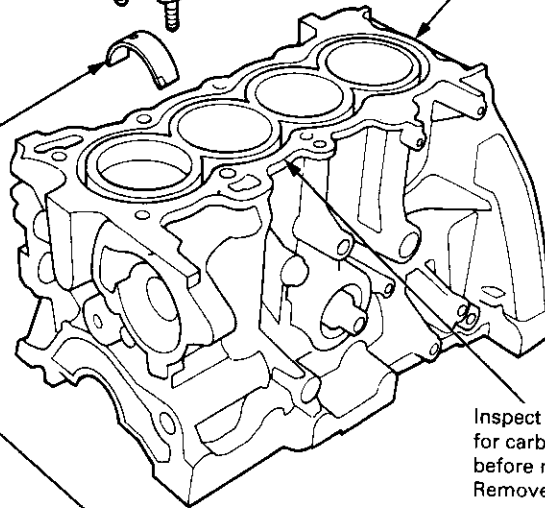

CONNECTING ROD BEARINGS

Clearance, page 7-11
Selection, page 7-11

Inspect top of each cylinder bore for carbon build-up or ridge before removing piston.
Remove ridge if necessary, page 7-13

CONNECTING ROD BEARING CAP

Installation, page 7-23
NOTE: Install caps so the bearing recess is on the same side as the recess in the rod.



CONNECTING ROD CAP NUT

B16A2 engine:

9 x 0.75 mm

40 N-m (4.1 kgf-m, 30 lbf-ft)

D16Y5, D16Y7, D16Y8 engines:

8 x 0.75 mm

31 N-m (3.2 kgf-m,
23 lbf-ft)

Apply engine oil to the bolt threads.

NOTE: After torquing each bearing cap, rotate crankshaft to check for binding.



Flywheel and Drive Plate

Replacement

Manual Transmission:

B16A2 engine:

Remove the eight flywheel bolts, then separate the flywheel from the crankshaft flange. After installation, tighten the bolts in the sequence shown.

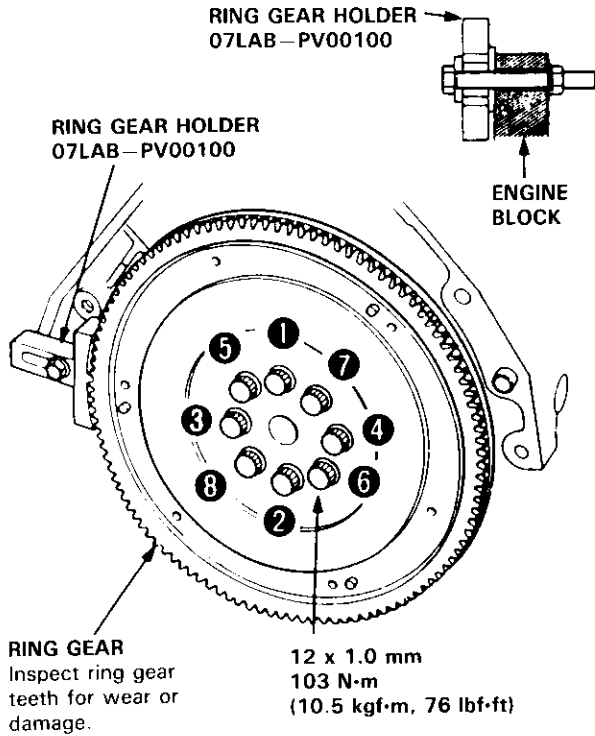

D16Y5, D16Y7, D16Y8 engines:

Remove the six flywheel bolts, then separate the flywheel from the crankshaft flange. After installation, tighten the bolts in a crisscross pattern.

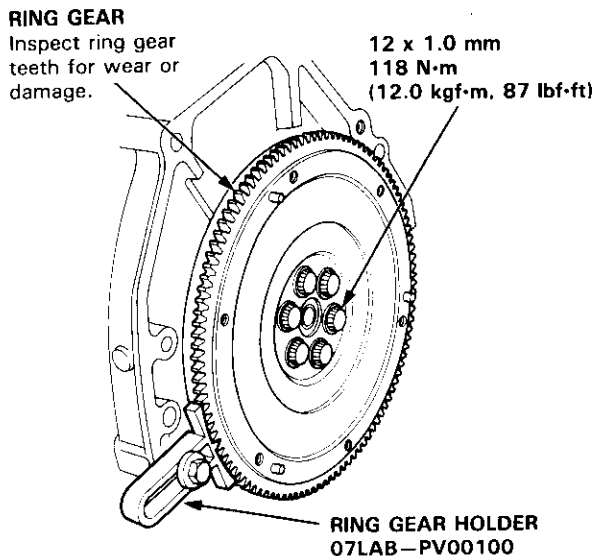

Automatic Transmission:

Remove the six drive plate bolts, then separate the drive plate from the crankshaft flange. After installation, tighten the bolts in a crisscross pattern.

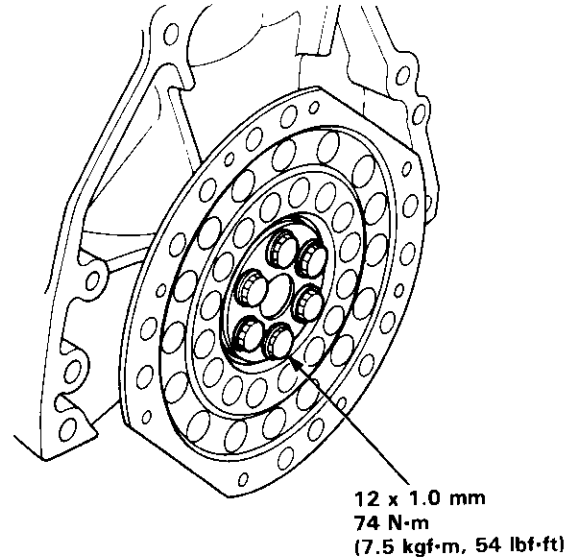

Connecting Rod and Crankshaft

End Play

Connecting Rod End Play:

Standard (New): 0.15 – 0.30 mm
(0.006 – 0.012 in)

Service Limit: 0.40 mm (0.016 in)

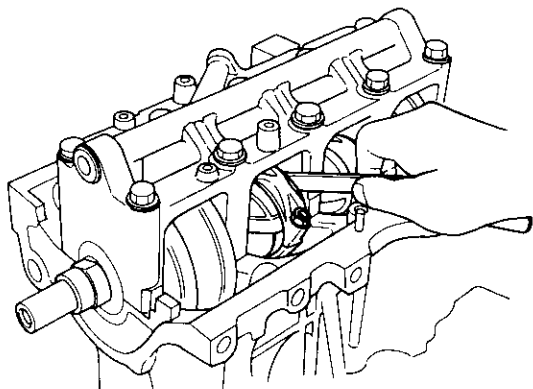

- If out-of-tolerance, install a new connecting rod.
- If still out-of-tolerance, replace the crankshaft (see pages 7-12 and 7-23).

Push the crankshaft firmly away from the dial indicator, and zero the dial against the end of the crankshaft. Then pull the crankshaft firmly back toward the indicator; dial reading should not exceed service limit.

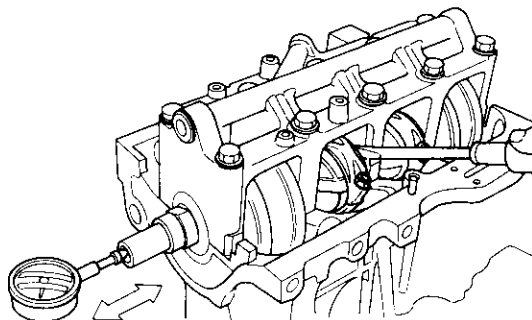

Crankshaft End Play:

Standard (New): 0.10 – 0.35 mm
(0.004 – 0.014 in)

Service Limit: 0.45 mm (0.018 in)

- If end play is excessive, inspect the thrust washers and thrust surface on the crankshaft. Replace parts as necessary.

NOTE: Thrust washer thickness is fixed and must not be changed either by grinding or shimming. Thrust washers are installed with grooved sides facing outward.

Main Bearings



Clearance

1. To check main bearing-to-journal oil clearance, remove the main caps and bearing halves.
2. Clean each main journal and bearing half with a clean shop towel.
3. Place one strip of plastigage across each main journal.

NOTE: If the engine is still in the car when you bolt the main cap down to check clearance, the weight of the crankshaft and flywheel will flatten the plastigage further than just the torque on the cap bolt, and give you an incorrect reading. For an accurate reading, support the crank with a jack under the counterweights and check only one bearing at a time.

4. Reinstall the bearings and caps, then torque the bolts.

1st step: 25 N·m (2.5 kgf·m, 18 lbf·ft)

Final step:

B16A2 engine:

76 N·m (7.8 kgf·m, 56 lbf·ft)

D16Y5, D16Y7, D16Y8 engines:

51 N·m (5.2 kgf·m, 38 lbf·ft)

NOTE: Do not rotate the crankshaft during inspection.

5. Remove the cap and bearing again, and measure the widest part of the plastigage.

Main Bearing-to-Journal Oil Clearance:

B16A2 engine:

Standard (New):

No. 1, 2, 4, 5 Journals:

0.024 – 0.042 mm (0.0009 – 0.0017 in)

No. 3 Journals:

0.030 – 0.048 mm (0.0012 – 0.0019 in)

Service Limit: 0.06 mm (0.002 in)

D16Y5, D16Y7, D16Y8 engines:

Standard (New):

No. 1, 5 Journals:

0.018 – 0.036 mm (0.0007 – 0.0014 in)

No. 2, 3, 4 Journals:

0.024 – 0.042 mm (0.0009 – 0.0017 in)

Service Limit: 0.05 mm (0.002 in)

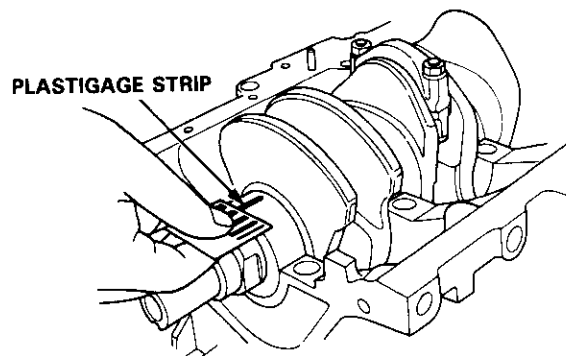

6. If the plastigage measures too wide or too narrow, (remove the engine if it's still in the car), remove the crankshaft, and remove the upper half of the bearing. Install a new, complete bearing with the same color code (select the color as shown on the next page), and recheck the clearance.

CAUTION: Do not file, shim, or scrape the bearings or the caps to adjust clearance.

7. If the plastigage shows the clearance is still incorrect, try the next larger or smaller bearing (the color listed above or below that one), and check again.

NOTE: If the proper clearance cannot be obtained by using the appropriate larger or smaller bearings, replace the crankshaft and start over.

Main Bearing

Selection

CAUTION: If the codes are indecipherable because of an accumulation of dirt and dust, do not scrub them with a wire brush or scraper. Clean them only with solvent or detergent.

Crankshaft Bore Code Location

B16A2 engine:

Letters have been stamped on the end of the block as a code for the size of each of the 5 main journal bores. Use them, and the numbers or bars stamped on the crank (codes for main journal size), to choose the correct bearings.

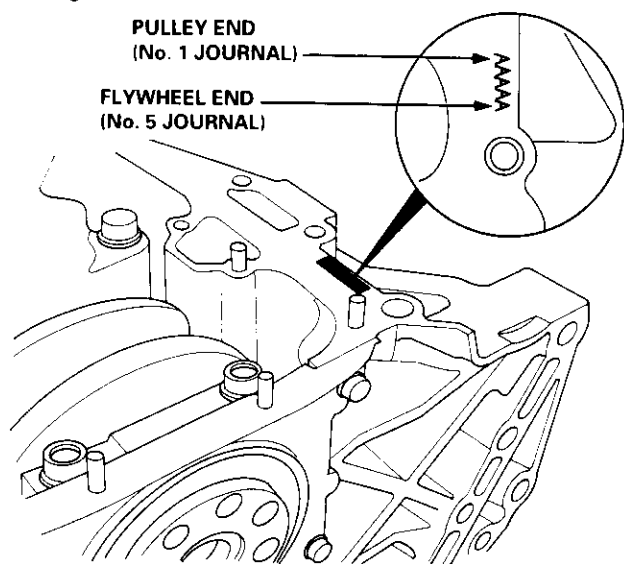

Main Journal Code Locations (Numbers or Bars)

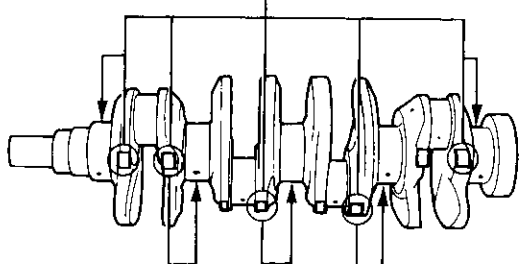

Bearing Identification

Color code is on the edge of the bearing.

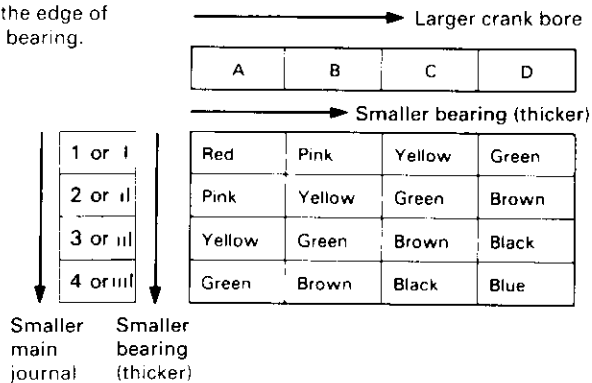

D16Y5, D16Y7, D16Y8 engines:

Letters have been stamped on the end of the block as a code for the size of each of the 5 main journal bores. Use them, and the numbers stamped on the crankshaft (codes for main journal size), to choose the correct bearings.

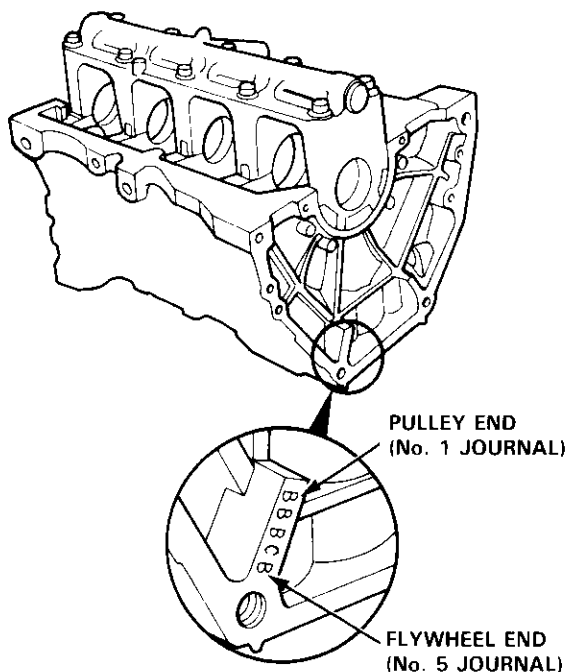

Main Journal Code Location (Numbers)

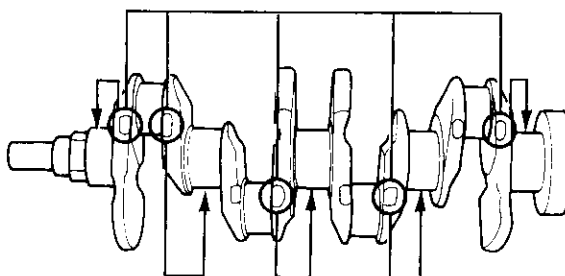

Bearing Identification

Color code is on the edge of the bearing.

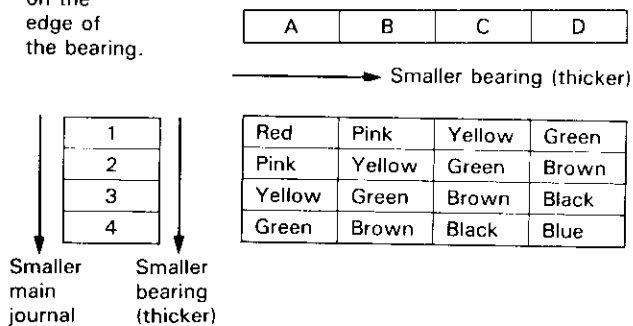

Connecting Rod Bearings



Clearance

1. Remove the connecting rod cap and bearing half.
2. Clean the crankshaft rod journal and bearing half with a clean shop towel.
3. Place plastigage across the rod journal.
4. Reinstall the bearing half and cap, and torque the nuts.

Torque

B16A2 engine:

40 N·m (4.1 kgf·m, 30 lbf·ft)

D16Y5, D16Y7, D16Y8 engines:

31 N·m (3.2 kgf·m, 23 lbf·ft)

NOTE: Do not rotate the crankshaft during inspection.

5. Remove the rod cap and bearing half and measure the widest part of the plastigage.

Connecting Rod Bearing-to-Journal Oil Clearance:

B16A2 engine:

Standard (New): 0.032 – 0.050 mm
(0.0013 – 0.0020 in)

Service Limit: 0.06 mm (0.002 in)

D16Y5, D16Y7, D16Y8 engines:

Standard (New): 0.020 – 0.038 mm
(0.0008 – 0.0015 in)

Service Limit: 0.05 mm (0.002 in)

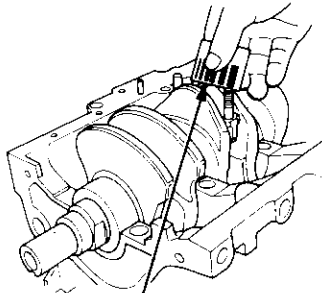

PLASTIGAGE STRIP

6. If the plastigage measures too wide or too narrow, remove the upper half of the bearing, install a new, complete bearing with the same color code (select the color as shown in the right column), and recheck the clearance.

CAUTION: Do not file, shim, or scrape the bearings or the caps to adjust clearance.

7. If the plastigage shows the clearance is still incorrect, try the next larger or smaller bearing (the color listed above or below that one), and check clearance again.

NOTE: If the proper clearance cannot be obtained by using the appropriate larger or smaller bearings, replace the crankshaft and start over.

Selection

CAUTION: If the codes are indecipherable because of an accumulation of dirt and dust, do not scrub them with a wire brush or scraper. Clean them only with solvent or detergent.

Connecting Rod Code Location

Numbers have been stamped on the side of each connecting rod as a code for the size of the big end. Use them, and the letters stamped on the crankshaft (codes for rod journal size), to choose the correct bearings.

Half of number is stamped on bearing cap and the other half is stamped on rod.

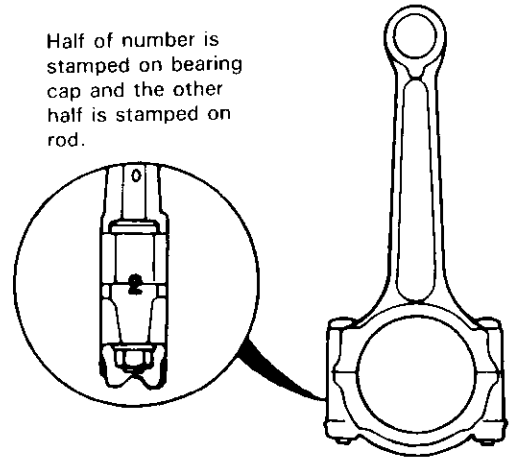

Connecting Rod Journal Code Locations (Letters)

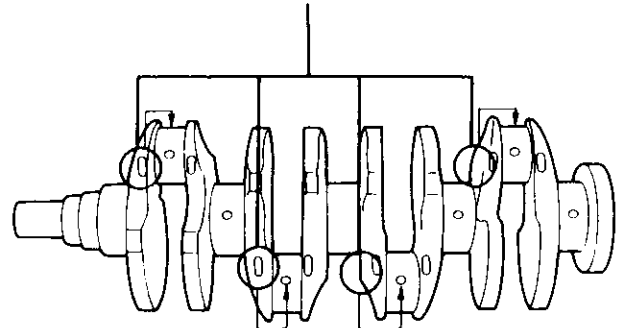

Bearing Identification

Color code is on the _____ → Larger big end bore edge of the bearing.

1	2	3	4
---	---	---	---

_____ → Smaller bearing (thicker)

A or I			
B or II			
C or III			
D or IIII			
Smaller rod journal	Smaller bearing (thicker)		
Red	Pink	Yellow	Green
Pink	Yellow	Green	Brown
Yellow	Green	Brown	Black
Green	Brown	Black	Blue

Pistons and Crankshaft

Removal

1. Remove the oil pan assembly.
2. Remove the right side cover.

B16A2 engine

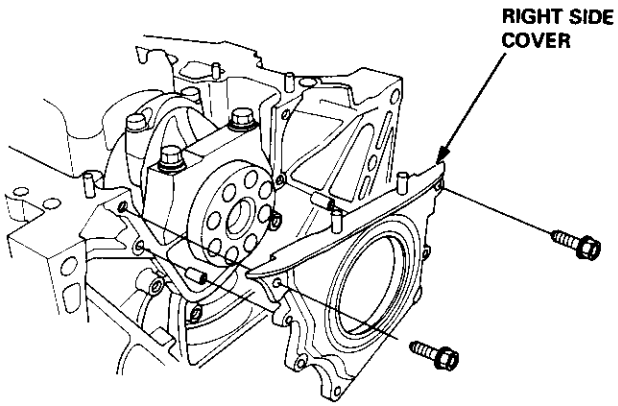

D16Y5, D16Y7, D16Y8 engines

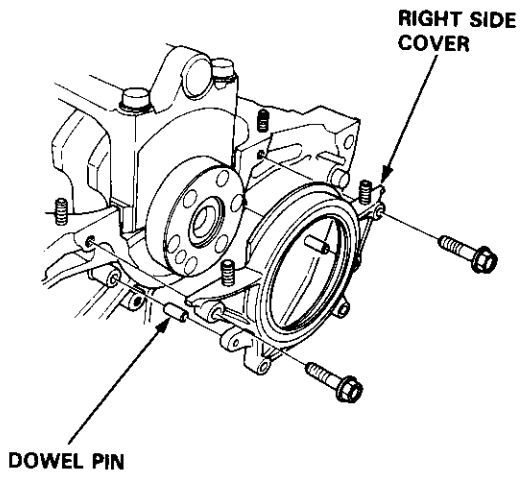

3. Remove the oil screen.
4. Remove the oil pump.

B16A2 engine

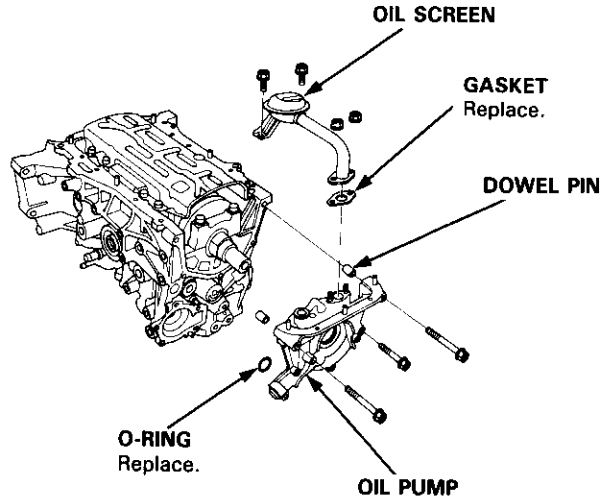

D16Y5, D16Y7, D16Y8 engines

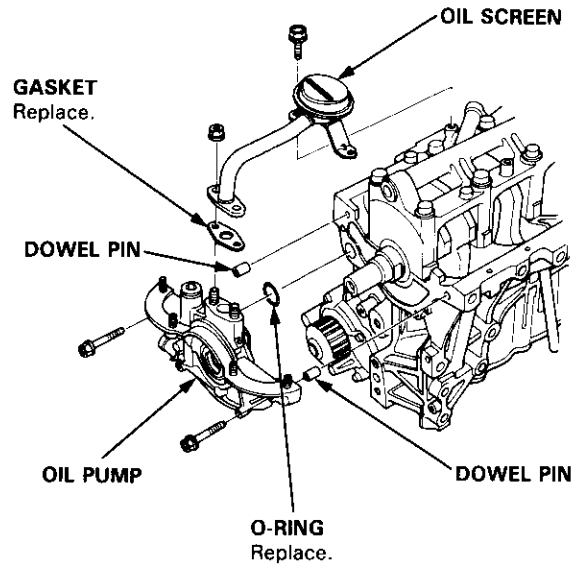

5. Remove the baffle plate (B16A2 engine).



6. Remove the bolts and the bearing caps.

CAUTION: To prevent warpage unscrew the bolts in sequence 1/3 turn at a time, repeat the sequence until all bolts are loosened.

MAIN BEARING CAP BOLTS LOOSENING SEQUENCE

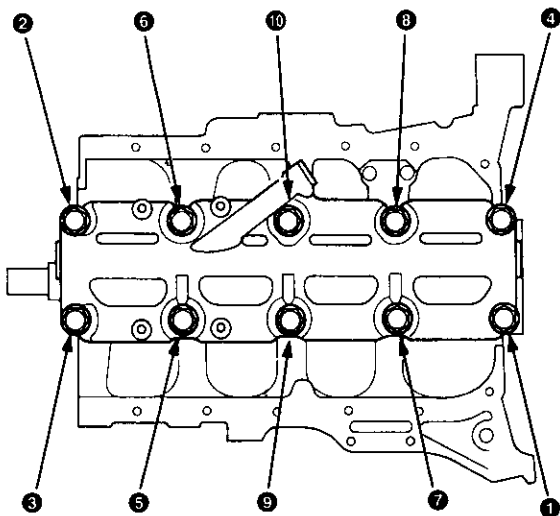

7. Remove the rod caps/bearings and main caps/bearings. Keep all caps/bearing in order.
8. Lift the crankshaft out of the engine, being careful not to damage journals.

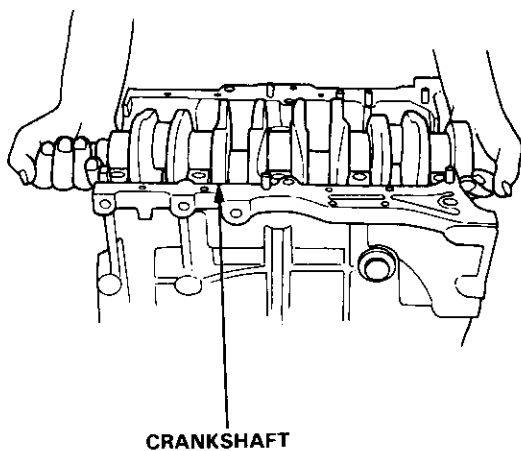

9. Remove the upper bearing halves from the connecting rods and set them aside with their respective caps.
10. Reinstall the main caps and bearings on the engine in proper order.
11. If you can feel ridge of metal or hard carbon around the top of each cylinder, remove it with a ridge reamer. Follow the reamer manufacturer's instructions.

CAUTION: If the ridge is not removed, it may damage the pistons as they are pushed out.

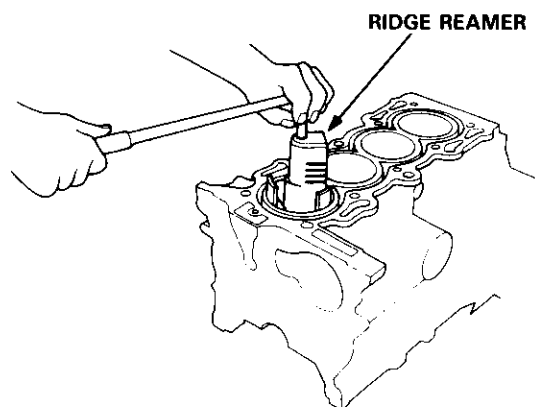

12. Use the wooden handle of a hammer to drive the pistons out.

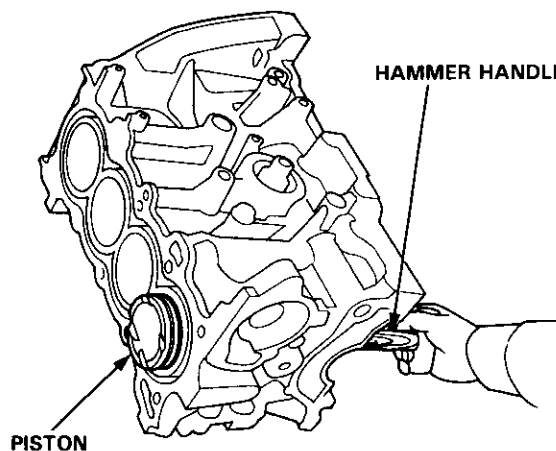

13. Reinstall the connecting rod bearings and caps after removing each piston/connecting rod assembly.
14. Mark each piston/connecting rod assembly with its cylinder number to avoid mixup on reassembly.

NOTE: The existing number on the connecting rod does not indicate its position in the engine, it indicates the rod bore size.

Crankshaft

Inspection

- Clean the crankshaft oil passages with pipe cleaners or a suitable brush.
- Check the keyway and threads.

Alignment

- Measure runout on all main journals to make sure the crank is not bent.
- The difference between measurements on each journal must not be more than the service limit.

Crankshaft Total Indicated Runout:

B16A2 engine:

Standard (New): 0.020 mm (0.0008 in) max.

Service Limit: 0.030 mm (0.0012 in)

D16Y5, D16Y7, D16Y8 engines:

Standard (New): 0.03 mm (0.001 in) max.

Service Limit: 0.04 mm (0.002 in)

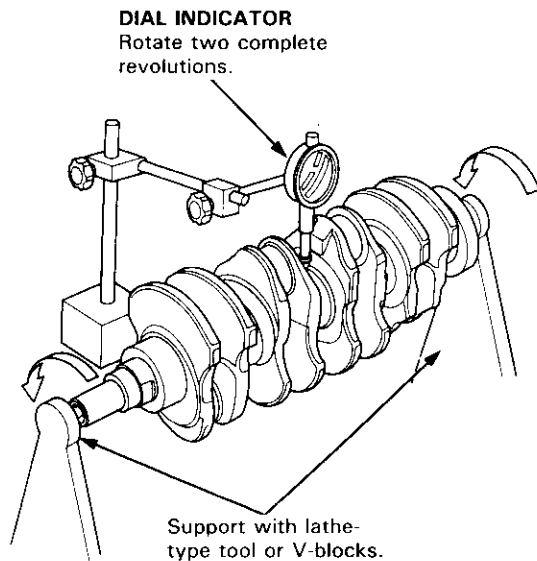

Out-of-Round and Taper

- Measure out-of-round at the middle of each rod and main journal in two places.
- The difference between measurements on each journal must not be more than the service limit.

Journal Out-of-Round:

B16A2 engine:

Standard (New): 0.0004 mm (0.0002 in) max.

Service Limit: 0.006 mm (0.0002 in)

D16Y5, D16Y7, D16Y8 engines:

Standard (New): 0.0025 mm (0.0001 in) max.

Service Limit: 0.005 mm (0.0002 in)

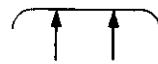
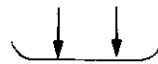
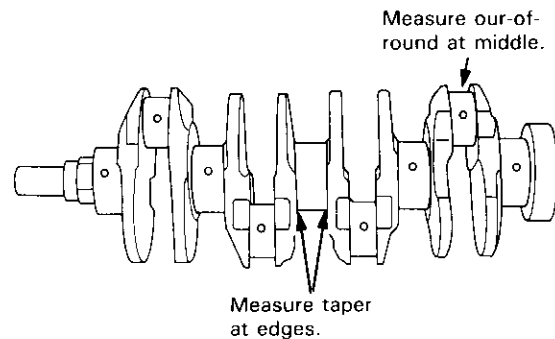
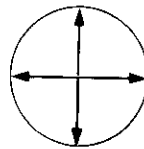

- Measure taper at the edges of each rod and main journal.
- The difference between measurements on each journal must not be more than the service limit.

Journal Taper:

B16A2 engine:

Standard (New): 0.005 mm (0.0002 in) max.

Service Limit: 0.010 mm (0.004 in)

D16Y5, D16Y7, D16Y8 engines:

Standard (New): 0.0025 mm (0.0001 in) max.

Service Limit: 0.005 mm (0.0002 in)



Inspection

1. Check the piston for distortion or cracks.

NOTE: If a cylinder is bored, an oversized piston must be used.

2. Measure the piston diameter at a distance A from bottom of the skirt.

B16A2 engine:

A: 15 mm (0.6 in)

D16Y5, D16Y7, D16Y8 engines:

A: 5 mm (0.2 in)

Piston Diameter:

B16A2 engine:

Standard (New): 80.980 – 80.990 mm
(3.1882 – 3.1886 in)

Service Limit: 80.970 mm (3.1878 in)

D16Y5, D16Y7, D16Y8 engines:

Standard (New): 74.980 – 74.990 mm
(2.9520 – 2.9524 in)

Service Limit: 74.970 mm (2.9516 in)

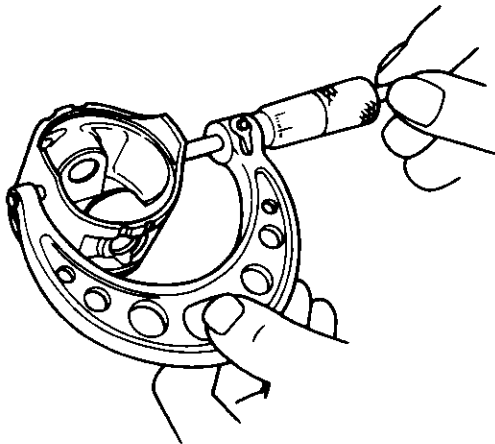
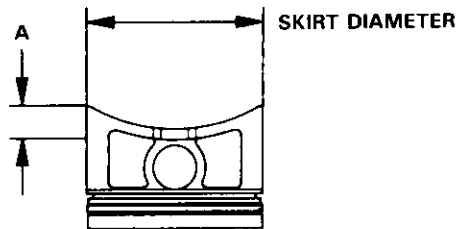

3. Calculate the difference between the cylinder bore diameter (see page 7-16) and the piston diameter.

Piston-to-Cylinder Clearance

Standard (New): 0.010 – 0.040 mm
(0.0004 – 0.0016 in)

Service Limit: 0.05 mm (0.002 in)

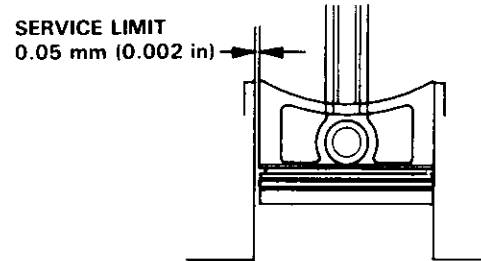

If the clearance is near or exceeds the service limit, inspect the piston and cylinder block for excessive wear.

Oversize Piston Diameter

B16A2 engine:

0.25: 81.23 – 81.24 mm (3.1980 – 3.1984 in)

D16Y5, D16Y7, D16Y8 engines:

0.25: 75.23 – 75.24 mm (2.9618 – 2.9622 in)

0.50: 75.48 – 75.49 mm (2.9716 – 2.9720 in)

Cylinder Block

Inspection

1. Measure wear and taper in directions X and Y at three levels in each cylinder as shown.

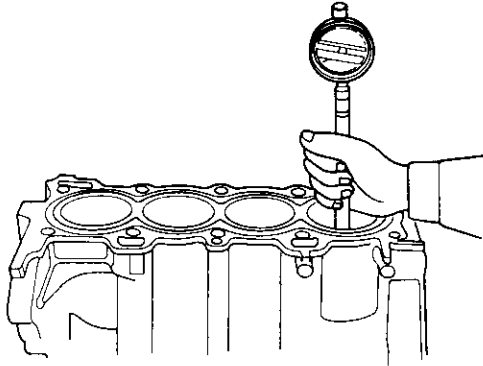
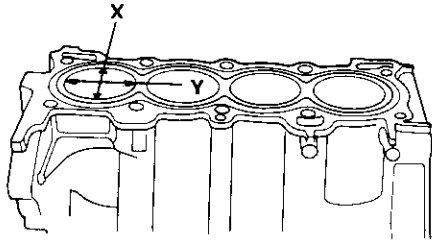
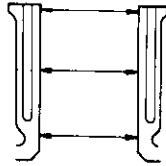

Cylinder Bore Size

B16A2 engine:

Standard (New): 81.00 – 81.02 mm
(3.183 – 3.190 in)

Service Limit: 81.07 mm (3.192 in)

D16Y5, D16Y7, D16Y8 engines:

Standard (New): 75.00 – 75.02 mm
(2.953 – 2.954 in)

Service Limit: 75.07 mm (2.956 in)

Oversize

B16A2 engine:

0.25: 81.25 – 81.27 mm (3.199 – 3.200 in)

D16Y5, D16Y7, D16Y8 engines:

0.25: 75.25 – 75.27 mm (2.9626 – 2.9634 in)

0.50: 75.50 – 75.52 mm (2.9724 – 2.9732 in)

Bore Taper

Limit: (Difference between first and third measurement) 0.05 mm (0.002 in)

- If the measurements in any cylinder are beyond the Oversize Bore Service Limit, replace the block.
- If the block is to be rebored, refer to Piston Clearance Inspection (see page 7-15) after reboring.

NOTE: Scored or scratched cylinder bores must be honed.

Reboring Limit:

B16A2 engine:

0.25 mm (0.01 in)

D16Y5, D16Y7, D16Y8 engines:

0.50 mm (0.02 in)

2. Check the top of the block for warpage. Measure along the edges and across the center as shown.

SURFACES TO BE MEASURED

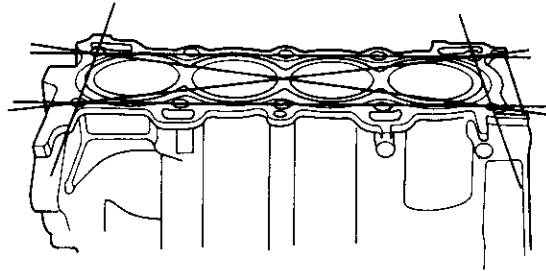

Engine Block Warpage:

B16A2 engine:

Standard (New): 0.05 mm (0.002 in) max.

Service Limit: 0.08 mm (0.003 in)

D16Y5, D16Y7, D16Y8 engines:

Standard (New): 0.07 mm (0.003 in) max.

Service Limit: 0.10 mm (0.004 in)

PRECISION STRAIGHT EDGE

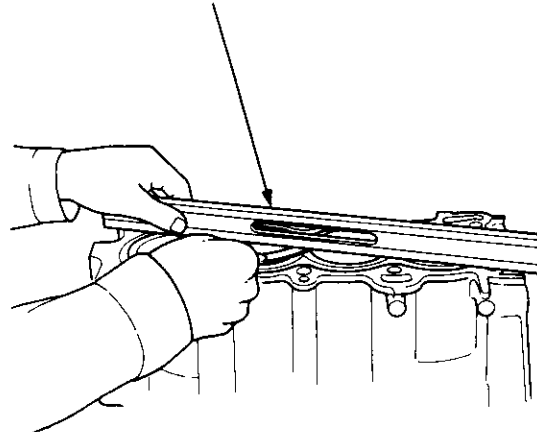



Bore Honing

1. Measure cylinder bores as shown on page 7-16. If the block is to be reused, hone the cylinders and remeasure the bores.
2. Hone cylinder bores with honing oil and a fine (400 grit) stone in a 60 degree cross-hatch pattern.

NOTE:

- Use only a rigid hone with 400 grit or finer stone such as Sunnen, Ammco, or equivalent.
- Do not use stones that are worn or broken.

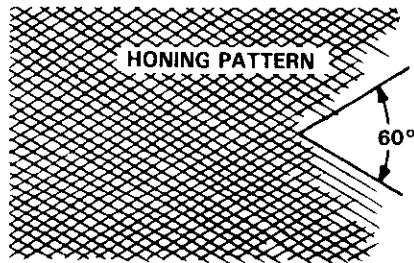

3. When honing is complete, thoroughly clean the engine block of all metal particles. Wash the cylinder bores with hot soapy water, then dry and oil immediately to prevent rusting.

NOTE: Never use solvent, it will only redistribute the grit on the cylinder walls.

4. If scoring or scratches are still present in cylinder bores after honing to the service limit, rebore the cylinder block.

NOTE: Some light vertical scoring and scratching is acceptable if it is not deep enough to catch your fingernail and does not run the full length of the bore.

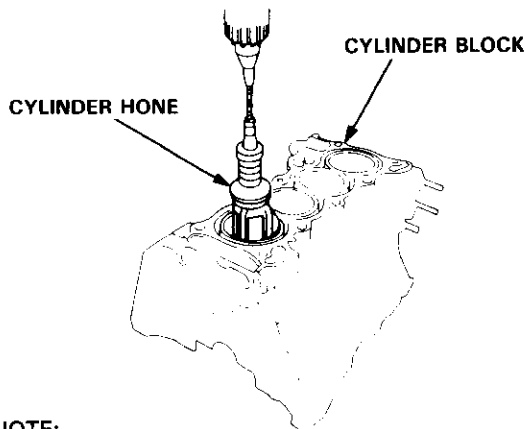

NOTE:

- After honing, clean the cylinder thoroughly with soapy water.
- Only a scored or scratched cylinder bore must be honed.

Removal

1. Assemble the special tool as shown.

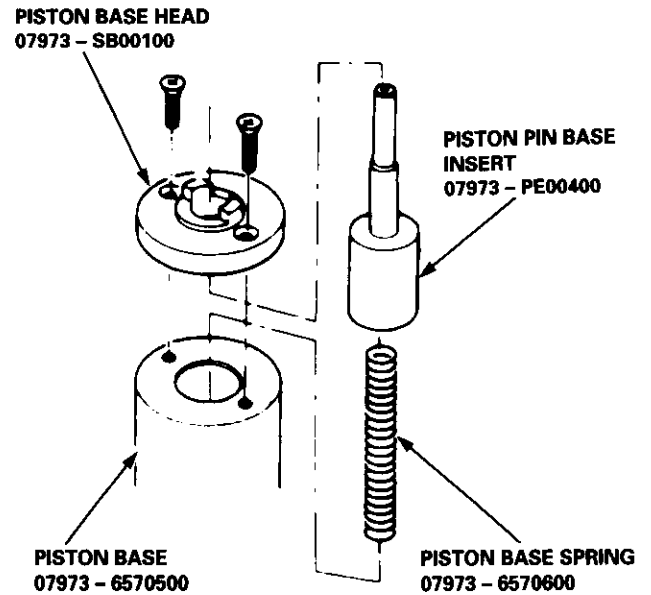

2. Assemble and adjust the length of the piston pin driver and shaft to 53 mm (2.1 in) as shown.

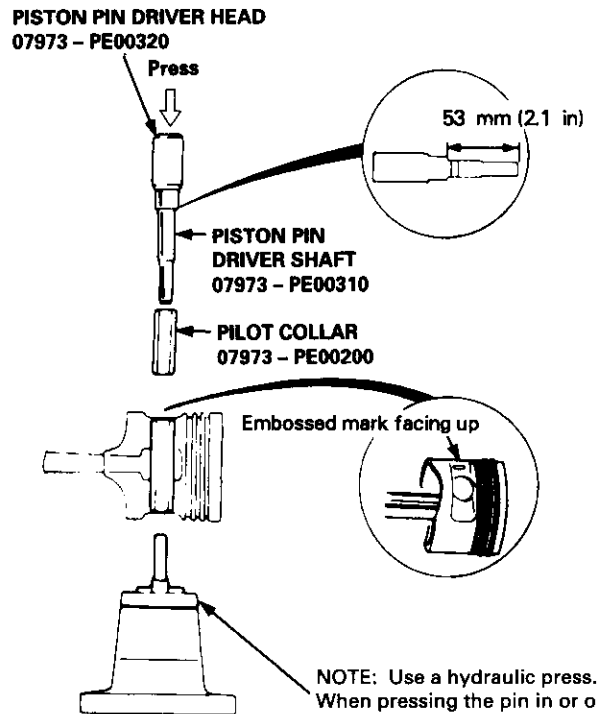

3. Place the piston on the special tool and press the pin out with the special tools and a hydraulic press.

Connecting Rods

Piston Pins

Selection

Each rod falls into one of four tolerance ranges (from 0 to + 0.024 mm (0 to + 0.0009 in), in 0.006 mm (0.0002 in) increments) depending on the size of its big end bore. It's then stamped with a number (1, 2, 3, or 4) indicating the range. You may find any combination of 1, 2, 3, or 4 in any engine.

Normal Bore Size: 48.0 mm (1.89 in)

NOTE:

- Reference numbers are for big end bore size and do NOT indicate the position of the rod in the engine.
- Inspect connecting rod for cracks and heat damage.

CONNECTING ROD BORE REFERENCE NUMBER

Half of number is stamped on bearing cap, the other half on connecting rod.

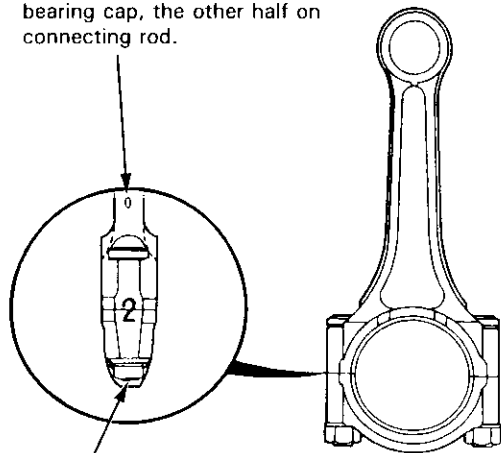

Inspect bolts and nuts for stress cracks.

Installation

1. Use a hydraulic press for installation.

- When pressing the pin in or out, be sure you position the recessed flat on the piston against the lugs on the base attachment.

B16A2 engine

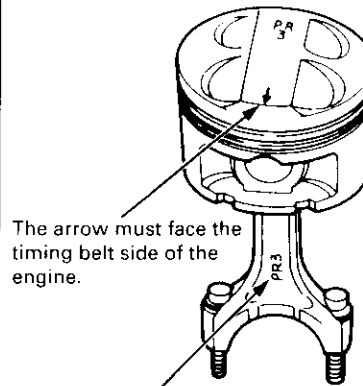

The arrow must face the timing belt side of the engine.

The mark must face the timing belt side of the engine.

D16Y5, D16Y7, D16Y8 engines

The arrow must face the timing belt side of the engine and the connecting rod oil hole must face the rear of the engine.

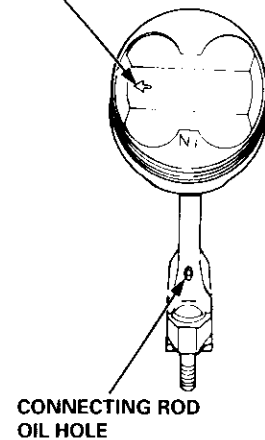

CONNECTING ROD OIL HOLE

PISTON PIN DRIVER HEAD 07973-PE00320

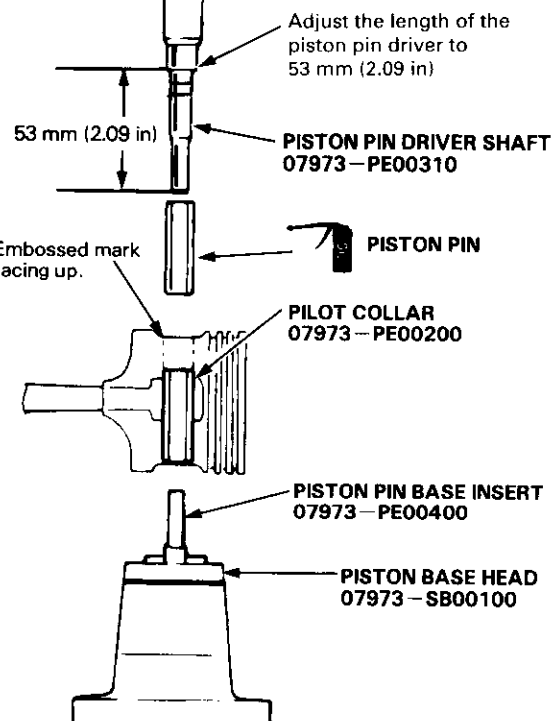

Adjust the length of the piston pin driver to 53 mm (2.09 in)

53 mm (2.09 in)

PISTON PIN DRIVER SHAFT 07973-PE00310

Embossed mark facing up.

PISTON PIN

PILOT COLLAR 07973-PE00200

PISTON PIN BASE INSERT 07973-PE00400

PISTON BASE HEAD 07973-SB00100



Inspection

1. Measure the diameter of the piston pin.

Piston Pin Diameter:

B16A2 engine:

Standard (New): 20.994 – 21.000 mm
(0.8265 – 0.8268 in)

Oversize: 20.997 – 21.003
(0.8267 – 0.8269 in)

D16Y5, D16Y7, D16Y8 engines:

Standard (New): 18.994 – 19.000 mm
(0.7478 – 0.7480 in)

Oversize: 18.997 – 19.003
(0.7479 – 0.7481 in)

NOTE: All replacement piston pins are oversize.

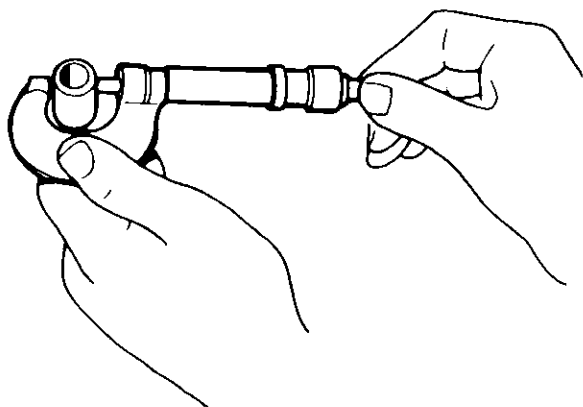

2. Zero the dial indicator to the piston pin diameter.

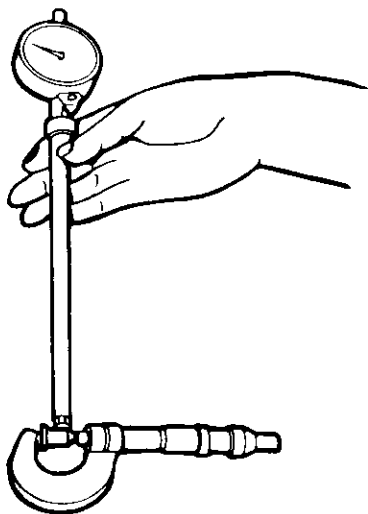

3. Measure the piston pin-to-piston clearance.

NOTE: Check the piston for distortion or cracks.

If the piston pin clearance is greater than 0.024 mm (0.0009 in), remeasure using an oversized piston pin.

Piston Pin-to-Piston Clearance:

Standard (New): 0.010 – 0.022 mm
(0.0004 – 0.0009 in)

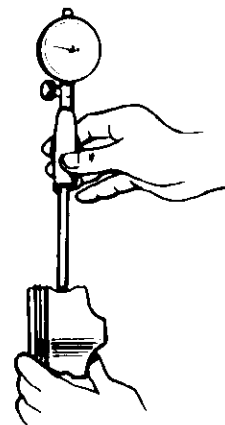

4. Check the difference between the piston pin diameter and the connecting rod small end diameter.

Piston Pin-to-Connecting Rod Interference:

B16A2 engine:

Standard (New): 0.013 – 0.032 mm
(0.0005 – 0.0013 in)

D16Y5, D16Y7, D16Y8 engines:

Standard (New): 0.014 – 0.040 mm
(0.0006 – 0.0016 in)

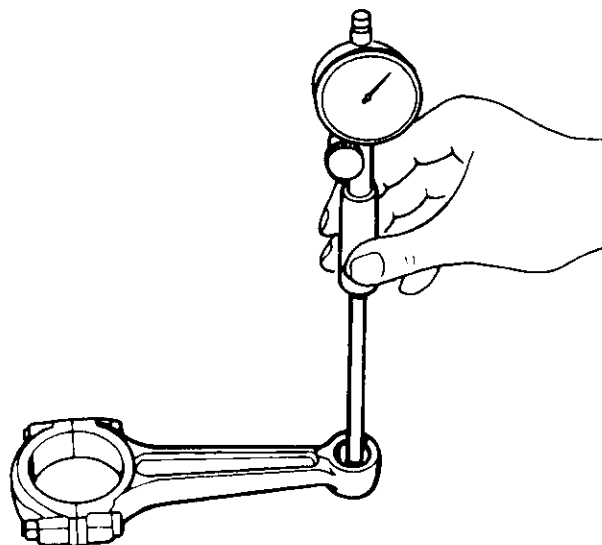

Piston Rings

End Gap

1. Using a piston, push a new ring into the cylinder bore 15 – 20 mm (0.6 – 0.8 in) from the bottom.
2. Measure the piston ring end-gap with a feeler gauge:
 - If the gap is too small, check to see if you have the proper rings for your engine.
 - If the gap is too large, recheck the cylinder bore diameter against the wear limits on page 7-16. If the bore is over the service limit, the cylinder block must be rebored.

Piston Ring End-Gap:

Top Ring

B16A2 engine

Standard (New): 0.20 – 0.35 mm
(0.008 – 0.014 in)

Service Limit: 0.60 mm (0.024 in)

D16Y5, D16Y7, D16Y8 engines

Standard (New): 0.15 – 0.30 mm
(0.006 – 0.012 in)

Service Limit: 0.60 mm (0.024 in)

Second Ring

B16A2 engine

Standard (New): 0.40 – 0.55 mm
(0.016 – 0.022 in)

Service Limit: 0.70 mm (0.028 in)

D16Y5, D16Y7, D16Y8 engines

Standard (New): 0.30 – 0.45 mm
(0.012 – 0.018 in)

Service Limit: 0.70 mm (0.028 in)

Oil Ring

B16A2 engine

Standard (New): 0.20 – 0.50 mm
(0.008 – 0.020 in)

Service Limit: 0.70 mm (0.028 in)

D16Y5, D16Y7, D16Y8 engines

Standard (New): 0.20 – 0.70 mm
(0.008 – 0.028 in)

Service Limit: 0.80 mm (0.031 in)

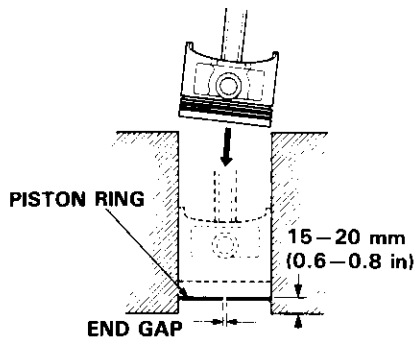

Replacement

1. Using a ring expander, remove the old piston rings.
2. Clean all ring grooves thoroughly.

NOTE:

- Use a squared-off broken ring or ring groove cleaner with blade to fit piston grooves.
- Top ring groove is 1.0 mm (0.039 in) wide.
- Second ring groove is 1.2 mm (0.047 in) wide.
- Oil ring groove is 2.8 mm (0.11 in) wide.
- File down the blade if necessary.

CAUTION: Do not use a wire brush to clean ring lands, or cut ring lands deeper with cleaning tool.

NOTE: If the piston is to be separated from the connecting rod, do not install new rings yet.

3. Install new rings in the proper sequence and position (see page 7-22).

NOTE: Do not reuse old piston rings.

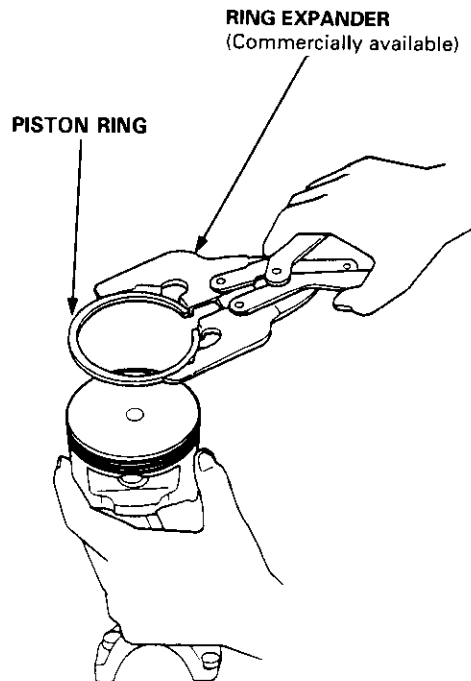



Ring-to-Groove Clearance

After installing a new set of rings, measure ring-to-groove clearances:

Top Ring Clearance

Standard (New):

B16A2 engine:

0.045 – 0.070 mm (0.0018 – 0.0028 in)

D16Y5, D16Y7, D16Y8 engines:

0.035 – 0.060 mm (0.0014 – 0.0024 in)

Service Limit: 0.13 mm (0.005 in)

Second Ring Clearance

Standard (New):

B16A2 engine:

0.040 – 0.065 mm (0.0016 – 0.0026 in)

D16Y5, D16Y7, D16Y8 engines:

0.030 – 0.055 mm (0.0012 – 0.0022 in)

Service Limit: 0.13 mm (0.005 in)

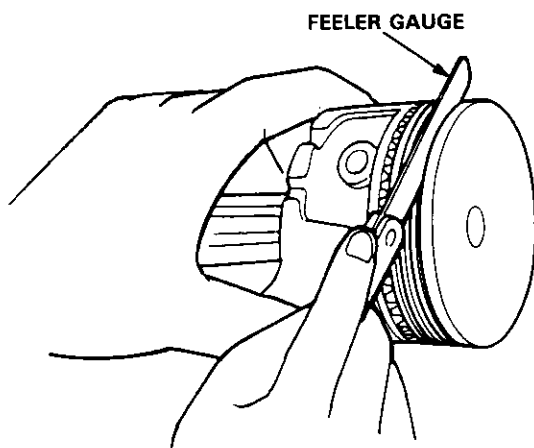

Alignment

1. Install the rings as shown.

NOTE: The manufacturing marks must be facing upward.

TOP RING (Chrome)

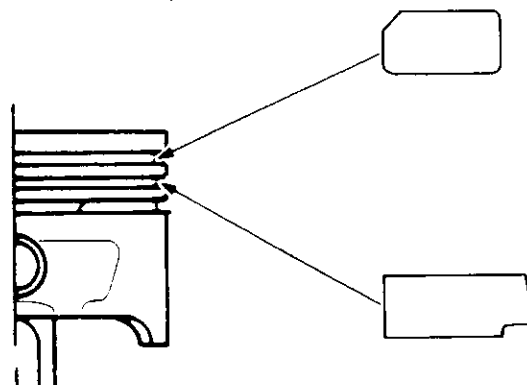

SECOND RING (Dark)

Piston Ring Dimensions:

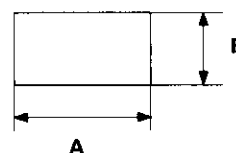

Top Ring (Standard)

Unit mm (in)

	A	B
B16A2 engine	3.1 (0.12)	1.0 (0.04)
D16Y5, D16Y7, D16Y8 engines	2.6 (0.10)	1.0 (0.04)

Second Ring (Standard)

Unit mm (in)

	A	B
B16A2 engine	3.3 (0.13)	1.2 (0.05)
D16Y5, D16Y7, D16Y8 engines	3.0 (0.12)	1.2 (0.05)

(cont'd)

Piston Rings

Crankshaft Oil Seal

Alignment (cont'd)

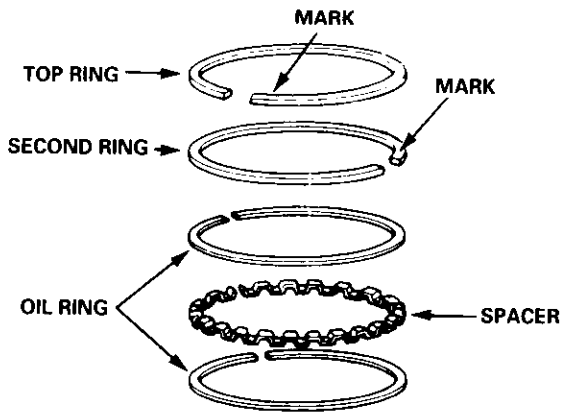

2. Rotate the rings in their grooves to make sure they do not bind.
3. Position the ring end gaps as shown:

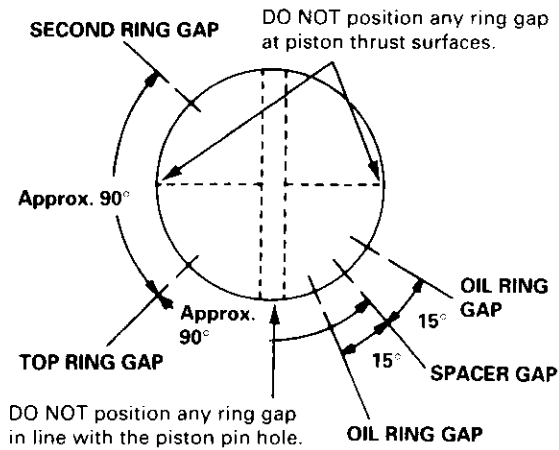

Installation

 The seal surface on the block should be dry. Apply a light coat of oil to the crankshaft and to the lip of the seal.

1. Drive the crankshaft oil seal squarely into the right side cover using the special tools.

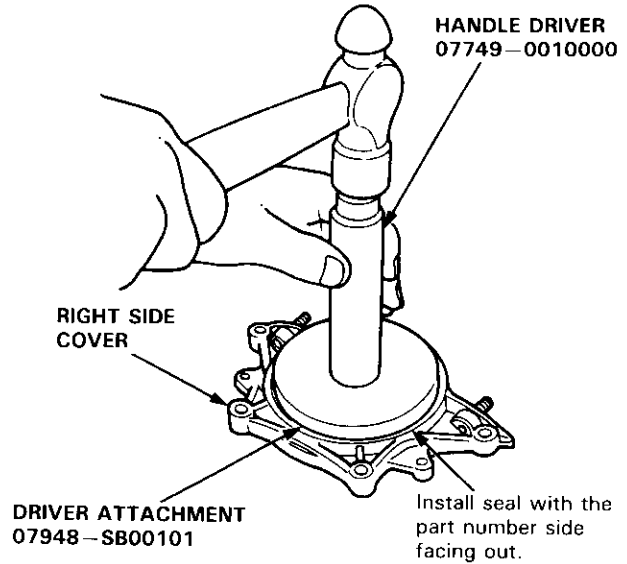

2. Confirm that the clearance is equal all the way around with a feeler gauge.

Clearance: 0.5 - 0.8 mm (0.02 - 0.03 in)

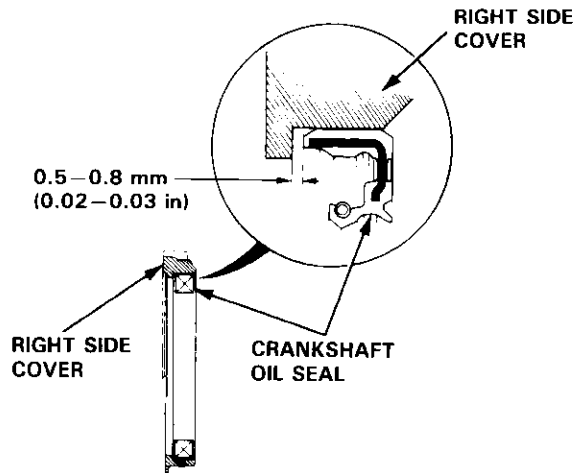

NOTE: Refer to page 8-14 for installation of the oil pump side crankshaft oil seal.



Installation

 Before installing the pistons, apply a coat of engine oil to the ring grooves and cylinder bores.

- If the crankshaft is already installed:
 - Set the crankshaft to BDC for each cylinder.
 - Remove the connecting rod caps, and slip short sections of rubber hose over the threaded ends of the connecting rod bolts.
 - Install the ring compressor, check that the bearing is securely in place, then position the piston in the cylinder, and tap it in using the wooden handle of a hammer.
 - Stop after the ring compressor pops free, and check the connecting rod-to-crank journal alignment before pushing the piston into place.
 - Apply engine oil to the bolt threads. Install the rod caps with bearings, and torque the nuts to:
 - B16A2 engine:**
40 N·m (4.1 kgf·m, 30 lbf·ft)
 - D16Y5, D16Y7, D16Y8 engines:**
31 N·m (3.2 kgf·m, 23 lbf·ft)

- If the crankshaft is not installed:
 - Remove the rod caps and bearings, install the ring compressor, then position the piston in the cylinder, and tap it in using the wooden handle of a hammer.
 - Position all pistons at top dead center.

The arrow must face the timing belt side of the engine.

CONNECTING ROD OIL HOLE (D16Y5, D16Y7, D16Y8 engines)

RUBBER HOSES

NOTE: Maintain downward force on the ring compressor to prevent the rings from expanding before entering the cylinder bore.

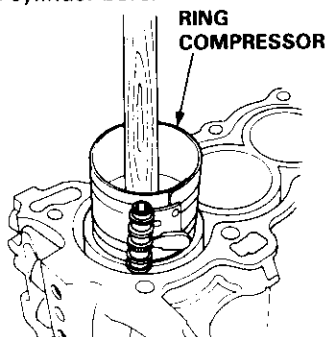

Installation

 Before installing the crankshaft, apply a coat of engine oil to the main bearings and rod bearings.

- Insert the bearing halves into the cylinder block and connecting rods.
- Hold the crankshaft so the rod journals for cylinders No. 2 and No. 3 are straight down.
- Lower the crankshaft into the block, seating the rod journals into connecting rods No. 2 and No. 3, and install the rod caps and nuts finger-tight.

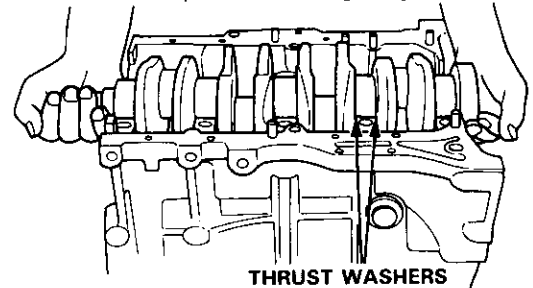

- Rotate the crankshaft clockwise, seat journals into connecting rods No. 1 and No. 4, and install the rod caps and nuts finger-tight.

NOTE: Install caps so the bearing recess is on the same side as the recess in the rod.

- Check rod bearing clearance with plastigage (see page 7-11), then torque the capnuts. Apply engine oil to the bolt threads.

Torque:

B16A2 engine:
40 N·m (4.1 kgf·m, 30 lbf·ft)
D16Y5, D16Y7, D16Y8 engines:
31 N·m (3.2 kgf·m, 23 lbf·ft)

NOTE: Reference numbers on connecting rod are for big-end bore tolerance and do not indicate the position of piston in the engine.

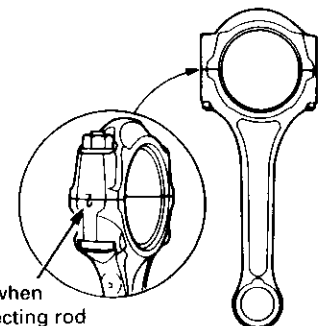

- Install the thrust washers on the No. 4 journal. Oil the thrust washer surfaces.

Crankshaft

Installation (cont'd)

7. Install the main bearing caps.
Check clearance with plastigage (see page 7-9), then tighten the bearing cap bolts in 2 steps.

First step: 25 N·m (2.5 kgf·m, 18 lbf·ft)

Second step:

B16A2 engine:

76 N·m (7.8 kgf·m, 56 lbf·ft)

D16Y5, D16Y7, D16Y8 engines:

51 N·m (5.2 kgf·m, 38 lbf·ft)

NOTE: Coat the thrust washer surfaces and bolt threads with oil.

MAIN BEARING CAP BOLTS TIGHTENING SEQUENCE

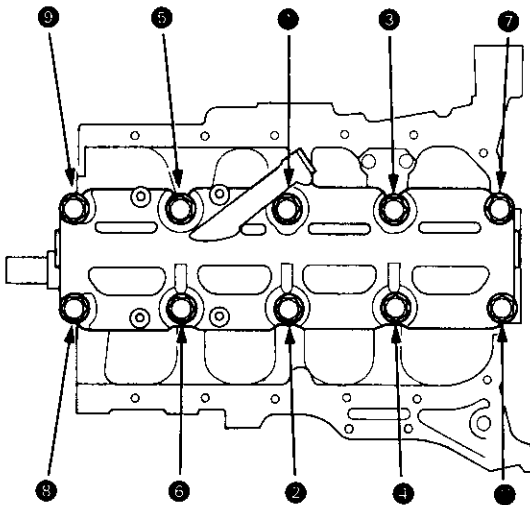

CAUTION: Whenever any crankshaft or connecting rod bearing is replaced, it is necessary after reassembly to run the engine at idling speed until it reaches normal operating temperature, then continue to run it for approximately 15 minutes.

NOTE:

- Use liquid gasket, part No. 08718 - 0001 or 08718 - 0003.
 - Check that the mating surfaces are clean and dry before applying liquid gasket.
 - Apply liquid gasket evenly, being careful to cover all the mating surface.
 - To prevent oil leakage, apply liquid gasket to the inner threads of the bolt holes.
 - Do not install the parts if five minutes or more have elapsed since applying the liquid gasket. Instead reapply liquid gasket after removing the old residue.
 - After assembly, wait at least 30 minutes before filling the engine with oil.
8. Apply liquid gasket to the block mating surface of the right side cover, then install it on the cylinder block.

B16A2 engine:

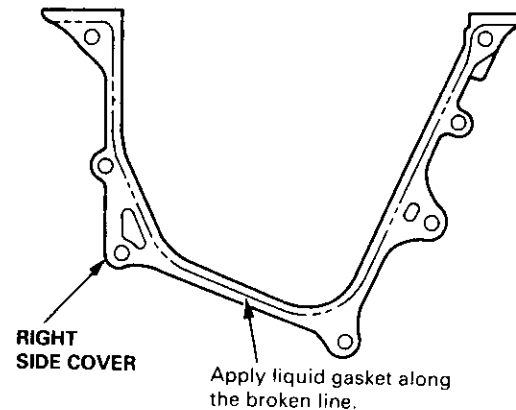

D16Y5, D16Y7, D16Y8 engines:

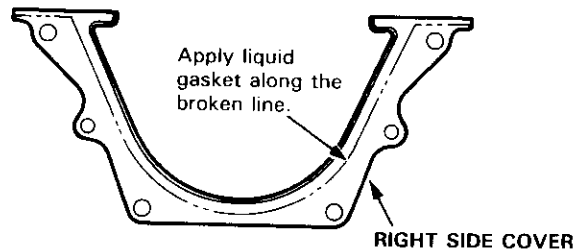



B16A2 engine:

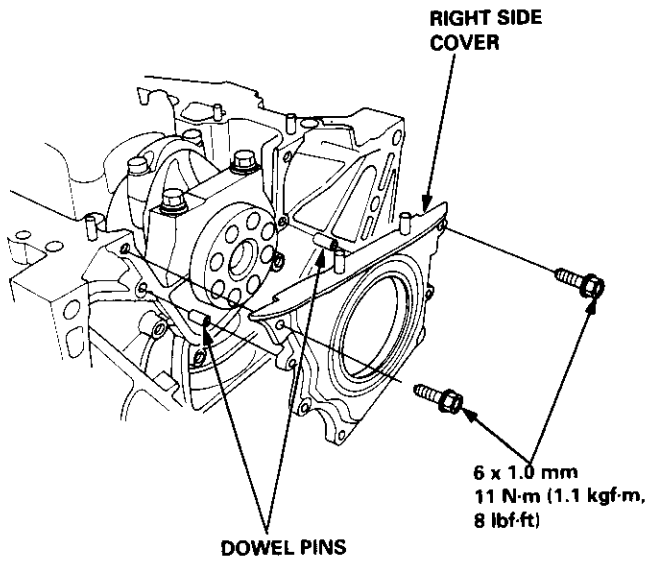

D16Y5, D16Y7, D16Y8 engines:

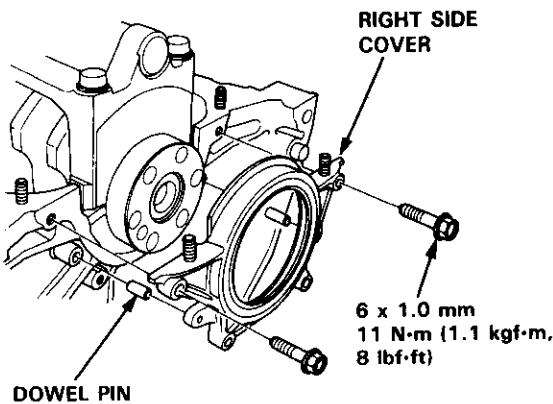

9. Apply liquid gasket to the oil pump mating surface of the block, then install the oil pump on the cylinder block.

Apply grease to the lips of the oil seals. Then, align the inner rotor with the crankshaft and install the oil pump. When the pump is in place, clean any excess grease off the crankshaft. Check that the oil seal lips are not distorted.

B16A2 engine:

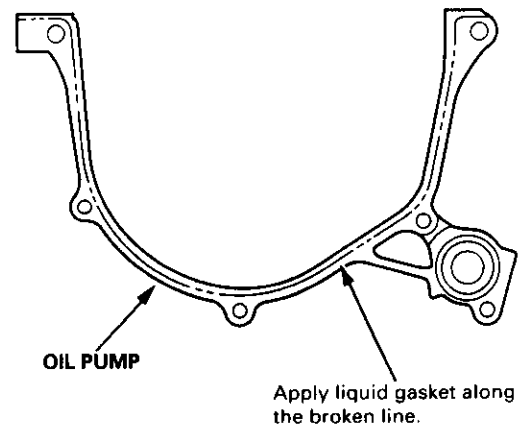

D16Y5, D16Y7, D16Y8 engines:

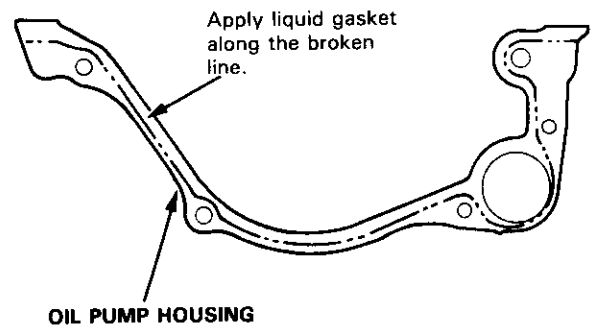

(cont'd)

Installation (cont'd)

NOTE:

- Apply a light coat of oil to the crankshaft and to the lip of seal.
- Use new O-rings and apply oil when installing them.

10. Install the oil screen.

B16A2 engine:

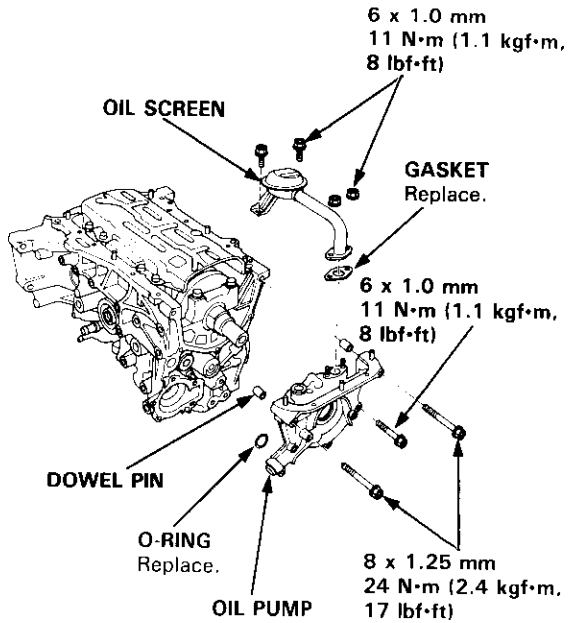

D16Y5, D16Y7, D16Y8 engines:

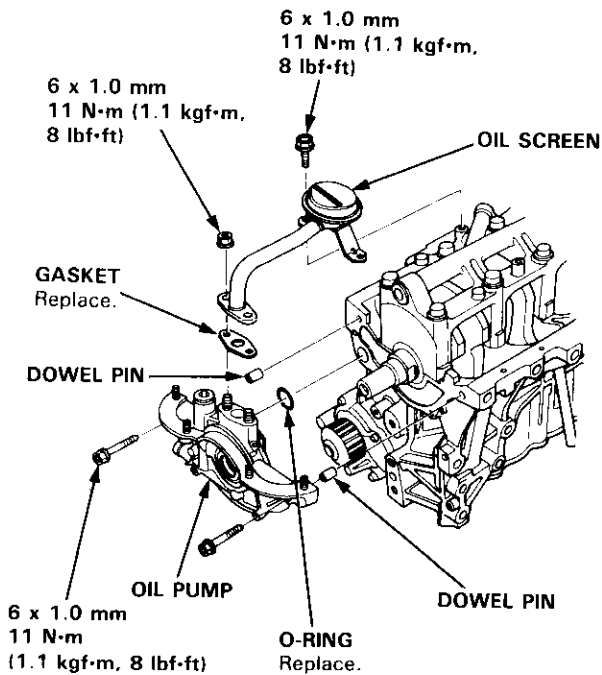

Installation

D16Y5, D16Y8 engines:

1. Install the oil pan gasket on the oil pan.

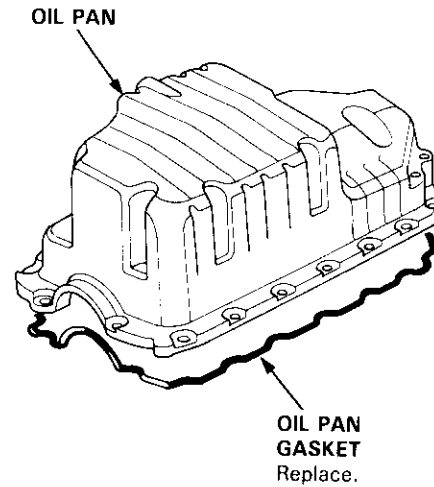



2. Apply liquid gasket to the block mating surfaces of the oil pan, then install it. Apply liquid gasket to the shaded areas.

NOTE:

- Use liquid gasket part No. 08718 - 0001 or 08718 - 0003.
- Check that the mating surfaces are clean and dry before applying liquid gasket.
- Apply liquid gasket as an even bead, centered between the edges of the mating surface.
- To prevent leakage of oil, apply liquid gasket to the inner threads of the bolt holes.
- Do not install the parts if five minutes or more have elapsed since applying the liquid gasket. Instead, reapply liquid gasket after removing the old residue.
- After assembly, wait at least 30 minutes before filling the engine with oil.

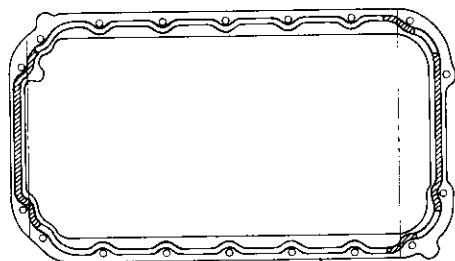

OIL PAN

3. Tighten nuts finger-tight at six points as shown below.

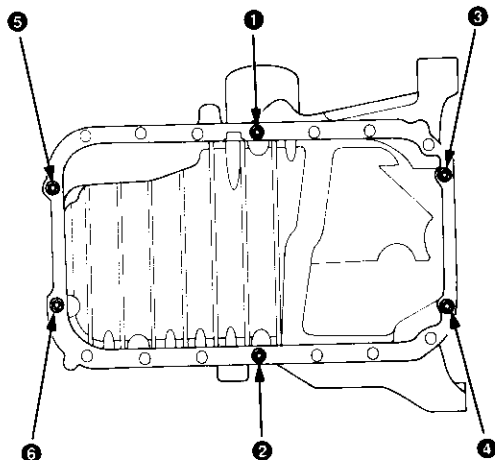

4. Tighten all bolts and nuts, starting from nut ①, clockwise in three steps.

NOTE: Excessive tightening can cause distortion of the oil pan gasket and oil leakage.

Torque: 12 N·m (1.2 kgf·m, 8.7 lbf·ft)

B16A2, D16Y7 engines:

1. Apply liquid gasket on the oil pump and right side cover mating areas as shown below.

NOTE:

- Use liquid gasket, part No. 08718 - 0001 or 08718 - 0003.
- Check that the mating surfaces are clean and dry before applying liquid gasket.
- Apply liquid gasket as an even bead, centered between the edges of the mating surface.
- To prevent oil leakage, apply liquid gasket to the inner threads of the bolt holes.
- Do not install the parts if five minutes or more have elapsed since applying the liquid gasket. Instead, reapply liquid gasket after removing the old residue.
- After assembly, wait at least 30 minutes before filling the engine with oil.

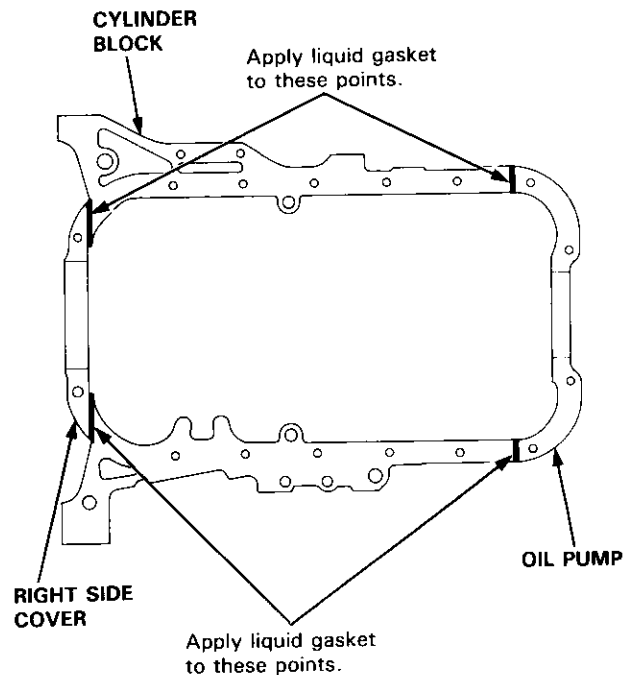

(cont'd)

Oil Pan

Installation (cont'd)

2. Install the oil pan gasket and oil pan.

NOTE:

- Use a new oil pan gasket.
- Install the oil pan no more than five minutes after applying liquid gasket.

B16A2 engine:

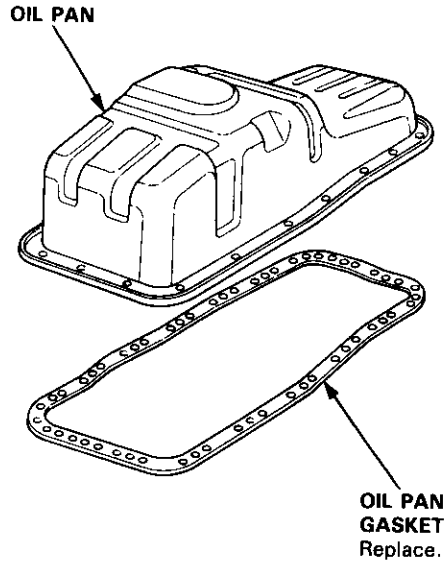

D16Y7 engine:

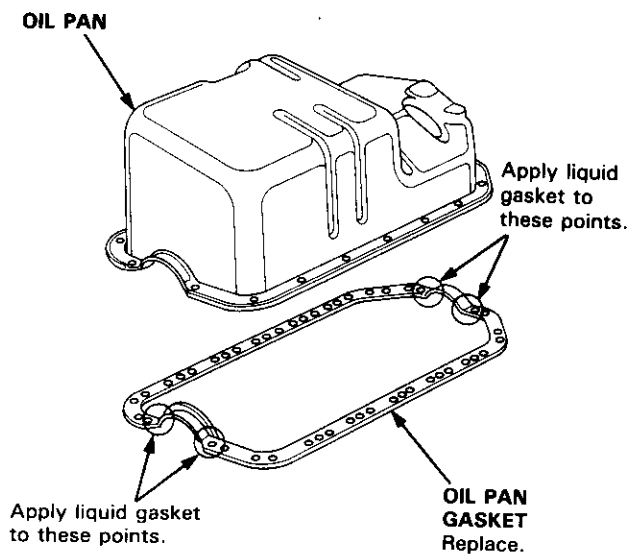

3. Tighten the bolts and nuts finger tight at six points as shown below.

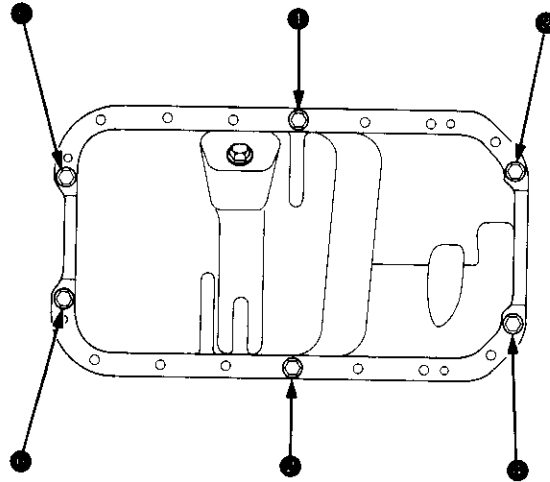

4. Tighten all bolts and nuts, starting from nut ①, clock wise in three steps.

NOTE: Excessive tightening can cause distortion of the oil pan gasket and oil leakage.

Torque: 12 N·m (1.2 kgf·m, 8.7 lbf·ft)



Installation

NOTE:

- Engine removal is not required.
- The crankshaft oil seal housing should be dry.
Apply a light coat of grease to the crankshaft and to the lips of the seals.

1. Using the special tool, drive in the timing pulley-end seal until the driver bottoms against the oil pump.
When the seal is in place, clean any excess grease off the crankshaft and check that the oil seal lip is not distorted.

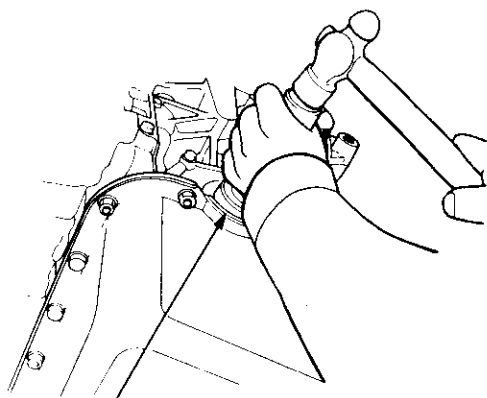

SEAL DRIVER
07947-SB00200
Install seal with the
part number side
facing out.

2. Measure the flywheel-end seal thickness and the oil seal housing depth. Using the special tool, drive the flywheel-end seal into the rear cover to the point where the clearance between the bottom of the oil seal and the right side cover is 0.5 – 0.8 mm (0.02 – 0.03 in) (see page 7-23).

NOTE: Align the hole in the driver attachment with the pin on the crankshaft.

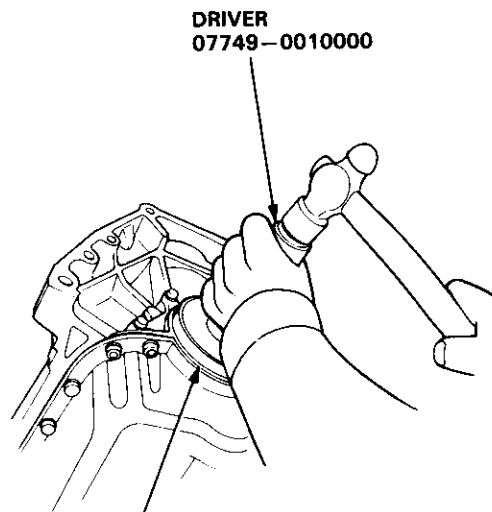

DRIVER
07749-0010000

DRIVER ATTACHMENT
07948-SB00101
Install seal with the
part number side
facing out.

Engine Lubrication

Special Tools	8-2
Illustrated Index	8-3
Engine Oil	
Inspection	8-6
Replacement.....	8-7
Oil Filter	
Replacement.....	8-8
Oil Pressure	
Testing	8-9
Oil Jet (B16A2 engine)	
Inspection	8-10
Oil Pump	
Overhaul.....	8-11
Removal/Inspection/Installation	8-13



Special Tools

Ref. No.	Tool Number	Description	Qty	Page Reference
①	07746 - 0010400	Attachment, 52 x 55 mm	1	8-14
②	07749 - 0010000	Driver	1	8-14
③	07912 - 6110001	Oil Filter Wrench	1	8-8



①



②

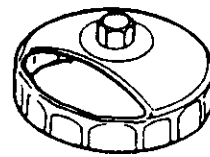

③

Illustrated Index



NOTE:

- Use new O-rings when reassembling.
- Apply oil to O-rings before installation.
- Use liquid gasket, Part No. 08718 - 0001 or 08718 - 0003.
- Clean the oil pan gasket mating surfaces before installing.

CAUTION: Do not overtighten the drain bolt.

B16A2 engine:

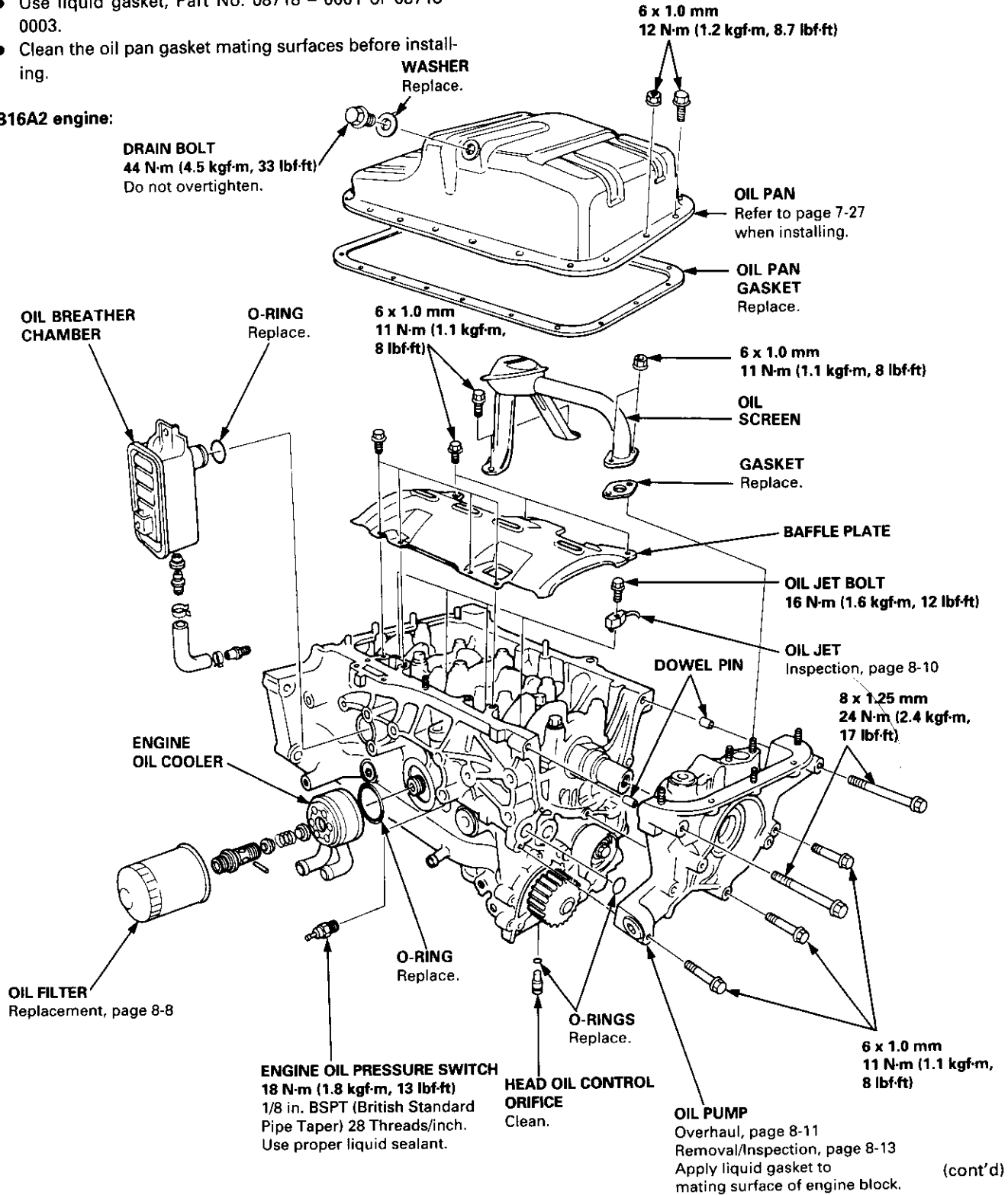

(cont'd)

Illustrated Index

(cont'd)

NOTE:

- Use new O-rings when reassembling.
- Apply oil to O-rings before installation.
- Use liquid gasket, Part No. 08718 - 0001 or 08718 - 0003.
- Clean the oil pan gasket mating surfaces before installing.
- Apply liquid gasket to the recesses of the oil pan gasket (see page 7-27).

CAUTION: Do not overtighten the drain bolt.

ENGINE OIL PRESSURE SWITCH

18 N·m (1.8 kgf·m, 13 lbf·ft)
 1/8 in. BSPT (British Standard Pipe Taper)
 28 threads/inch. Use proper liquid sealant.

D16Y7 engine:

OIL PUMP

Overhaul, page 8-12
 Inspection, page 8-13
 Apply liquid gasket to the mating surface of the block.

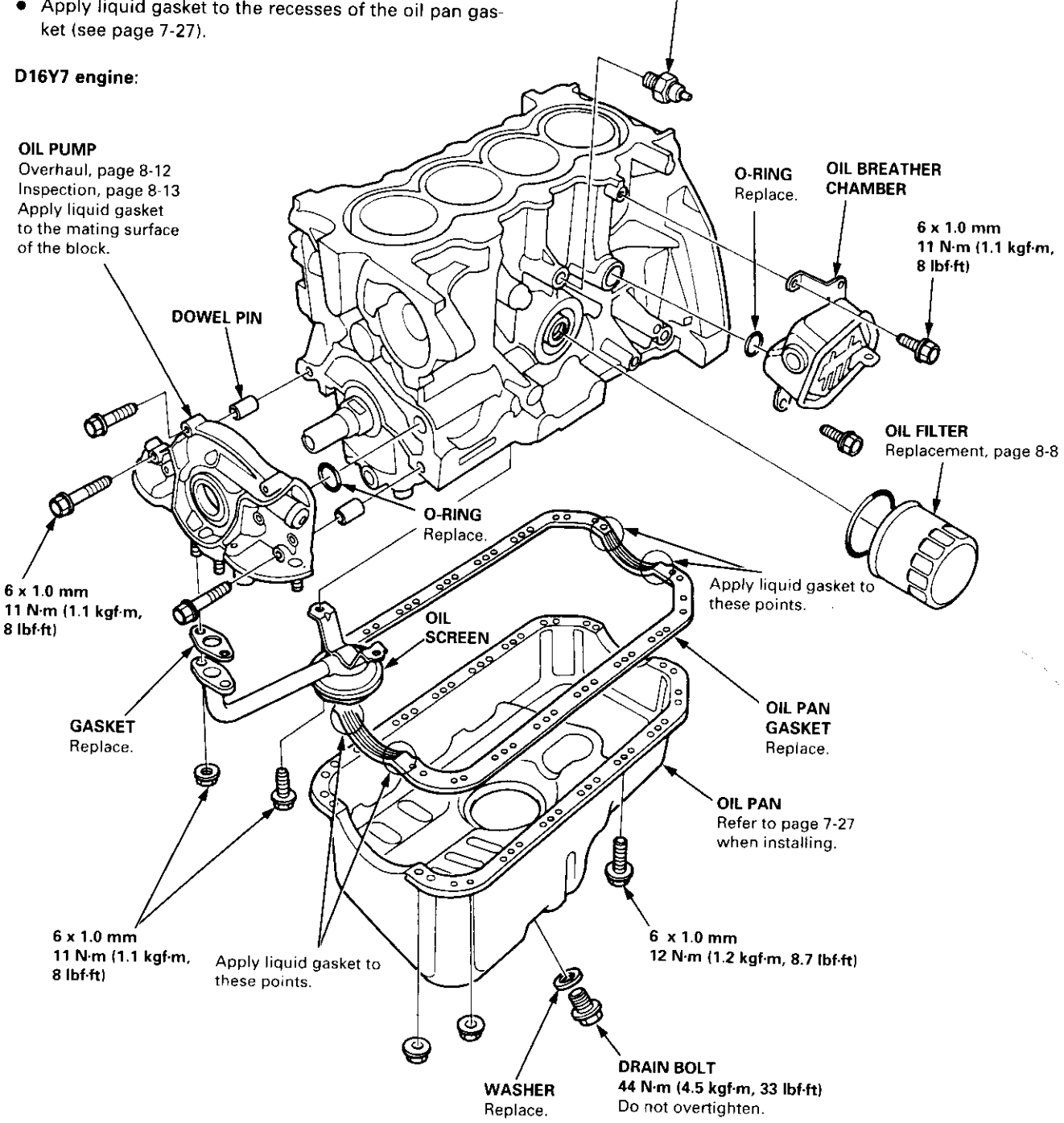

DOWEL PIN

O-RING
Replace.

OIL BREATHER CHAMBER

6 x 1.0 mm
 11 N·m (1.1 kgf·m, 8 lbf·ft)

OIL FILTER
 Replacement, page 8-8

6 x 1.0 mm
 11 N·m (1.1 kgf·m, 8 lbf·ft)

O-RING
Replace.

Apply liquid gasket to these points.

GASKET
Replace.

OIL SCREEN

OIL PAN GASKET
Replace.

OIL PAN
 Refer to page 7-27 when installing.

6 x 1.0 mm
 11 N·m (1.1 kgf·m, 8 lbf·ft)

Apply liquid gasket to these points.

6 x 1.0 mm
 12 N·m (1.2 kgf·m, 8.7 lbf·ft)

WASHER
Replace.

DRAIN BOLT
 44 N·m (4.5 kgf·m, 33 lbf·ft)
 Do not overtighten.



NOTE:

- Use new O-rings when reassembling.
- Apply oil to O-rings before installation.
- Use liquid gasket, Part No. 08718 - 0001 or 08718 - 0003.
- Clean the oil pan gasket mating surfaces before installing.

CAUTION: Do not overtighten the drain bolt.

D16Y5, D16Y8 engines:

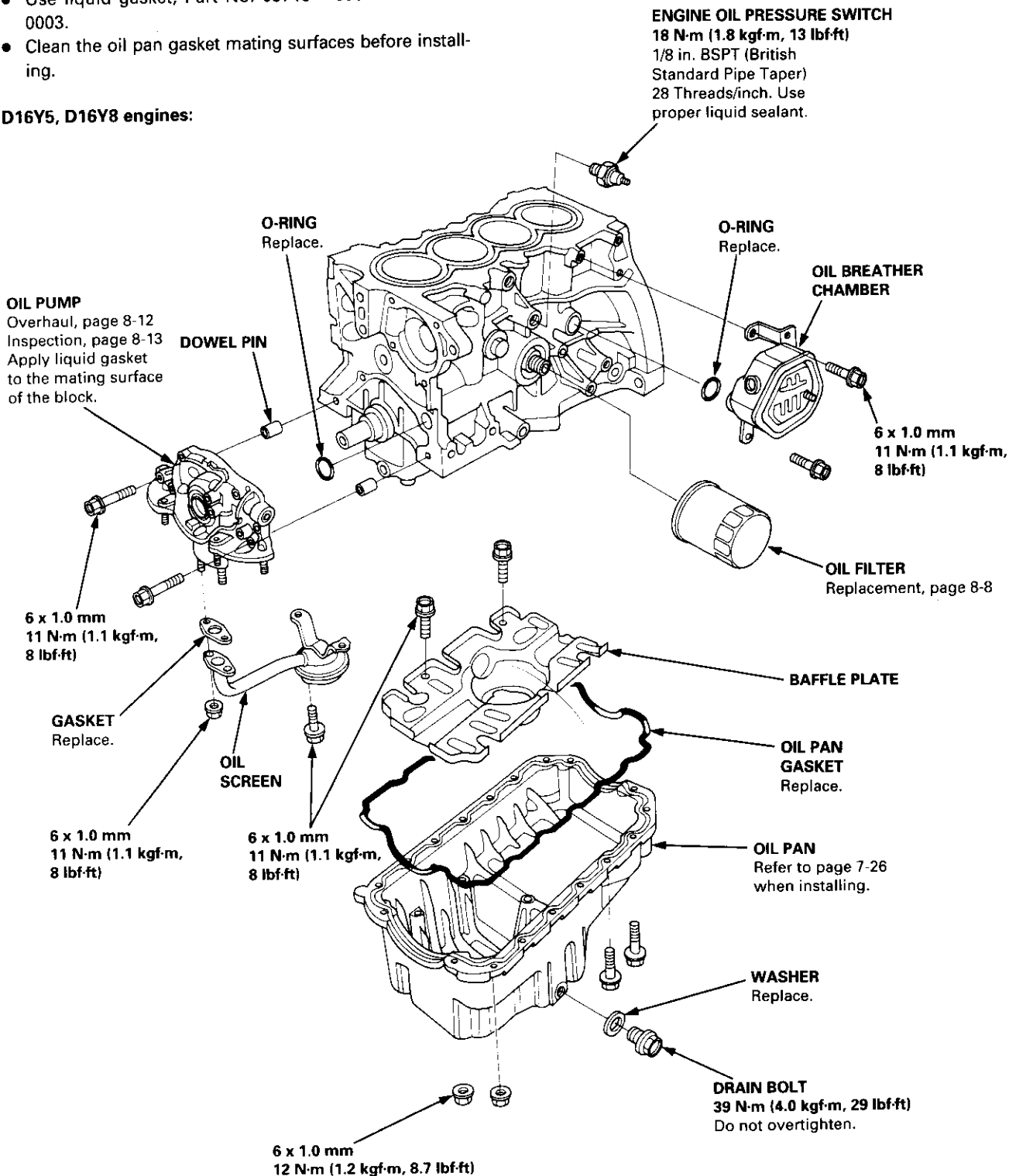

Engine Oil

Inspection

1. Park the vehicle on level ground, and turn off the engine. Allow the oil a few minutes to drain back into the oil pan so the dipstick will show the actual level.
2. Make certain that the oil level indicated on the dipstick is between the upper and lower marks.
3. If the level has dropped close to the lower mark, add oil until it reaches the upper mark.

CAUTION: Insert the dipstick carefully to avoid bending it.

B16A2 engine:

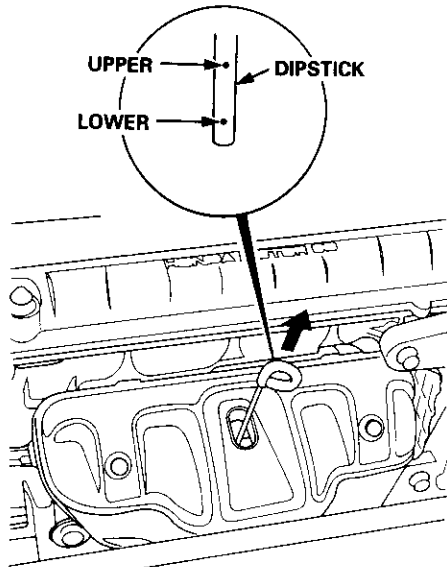

D16Y5, D16Y7, D16Y8 engines:

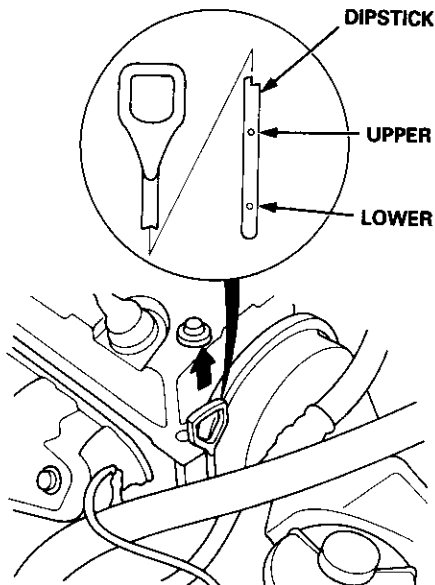

Replacement

CAUTION: Remove the drain bolt carefully while the engine is hot; the hot oil may cause scalding.

1. Warm up the engine.
2. Drain the engine oil.

B16A2, D16Y7 engines:

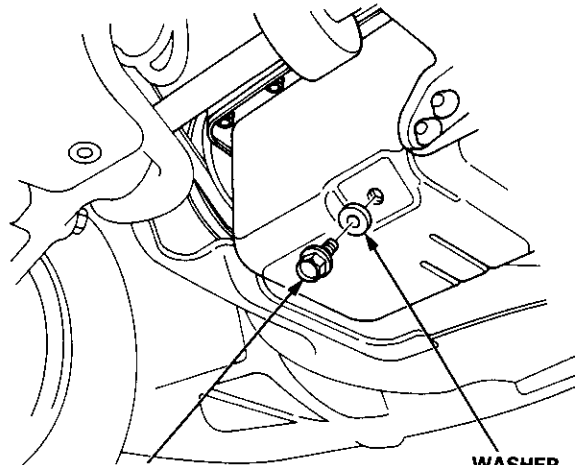

DRAIN BOLT
44 N·m (4.5 kgf·m, 33 lbf·ft)
Do not overtighten.

WASHER
Replace.

D16Y5, D16Y8 engines:

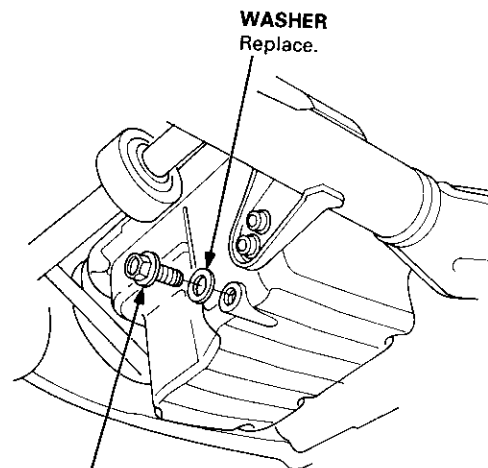

DRAIN BOLT
39 N·m (4.0 kgf·m, 29 lbf·ft)
Do not overtighten.



- Reinstall the drain bolt with a new washer, and refill the engine with the recommended oil.

Requirement	API Service Grade: Use an "Energy Conserving" SJ grade oil or an "Energy Conserving II" SH grade oil, SAE 5W - 30 preferred. You can also use an oil that bears the API CERTIFICATION mark.
Capacity	B16A2 engine: 3.7 l (3.9 US qt, 3.3 Imp qt) at oil change. 4.0 l (4.2 US qt, 3.5 Imp qt) at oil change, including filter. 4.8 l (5.1 US qt, 4.2 Imp qt) after engine overhaul. D16Y7 engine: 3.6 l (3.8 US qt, 3.2 Imp qt) at change, including filter. 3.3 l (3.5 US qt, 2.9 Imp qt) at change, without filter. 4.3 l (4.5 US qt, 3.8 Imp qt) after engine overhaul. D16Y5, D16Y8 engines: 3.3 l (3.5 US qt, 2.9 Imp qt) at change, including filter. 3.0 l (3.2 US qt, 2.6 Imp qt) at change, without filter. 3.7 l (3.9 US qt, 3.3 Imp qt) after engine overhaul.
Change	Every 7,500 miles (12,000 km) or 12 months (Normal Conditions). Every 3,750 miles (6,000 km) or 6 months (Severe Conditions).

NOTE: Under normal conditions, the oil filter should be replaced at every other oil change. Under severe conditions, the oil filter should be replaced at each oil change. The numbers in the middle of the API Service label tell you the oil's SAE viscosity or weight. Select the oil for your car according to this chart:

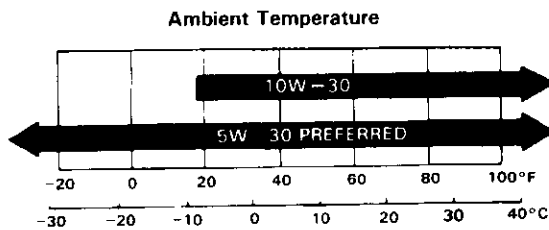

An oil with a viscosity of 5W - 30 is preferred for improved fuel economy and year-round protection in the car. You may use a 10W - 30 oil if the climate in your area is limited to the temperature range shown on the chart.



API CERTIFICATION MARK

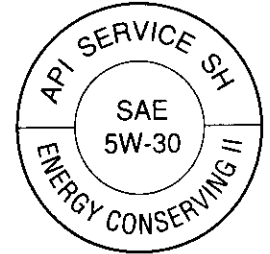
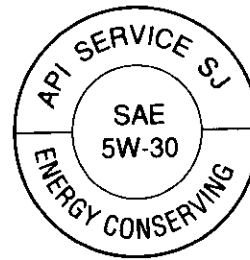

API SERVICE LABEL

- Run the engine for more than three minutes, then check for oil leakage.

Oil Filter

Replacement

⚠ WARNING

- After the engine has been run, the exhaust pipe will be hot; be careful when working around the exhaust pipe.
- Be careful when loosening the drain bolt while the engine is hot. Burns can result because the oil temperature is very high.

1. Remove the oil filter with the oil filter wrench.
2. Inspect the threads and rubber seal on the new filter. Wipe off the seat on the engine block, then apply a light coat of oil to the new filter's rubber seal.

NOTE: Use only filters with a built-in bypass system.

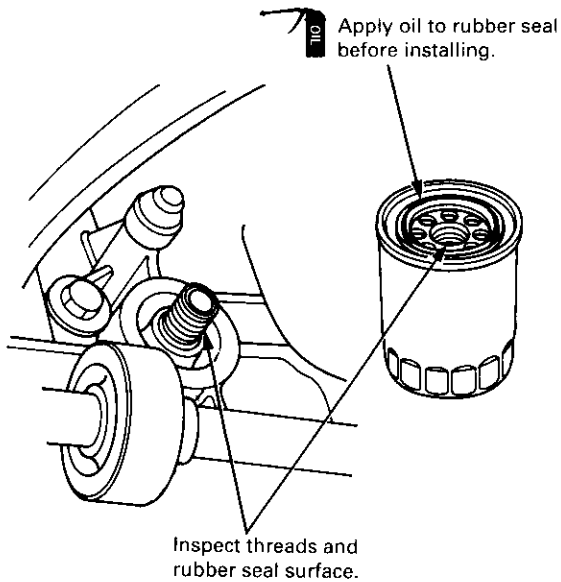

3. Install the oil filter by hand.
4. After the rubber seal seats, tighten the oil filter clockwise with the oil filter wrench.

Tighten: 7/8 turn clockwise.

Tightening torque: 22 N·m (2.2 kgf·m, 16 lbf·ft)

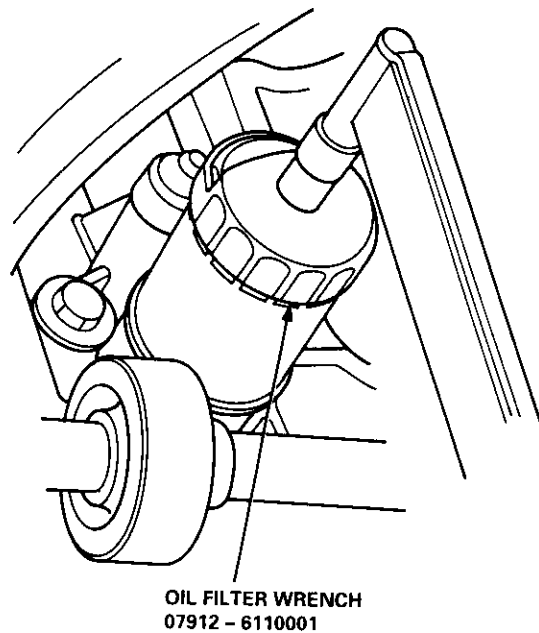



Use this procedure to tighten the filter if eight numbers (1 to 8) are printed on the surface of the filter.

- 1) Make a mark on the oil filter base under the number that shows at the bottom of the filter when the rubber seal is seated.
- 2) Tighten the filter by turning it clockwise seven numbers from the marked point. For example, if a mark is made under the number 2 when the rubber seal is seated, the filter should be tightened until the number 1 comes up to the marked point.

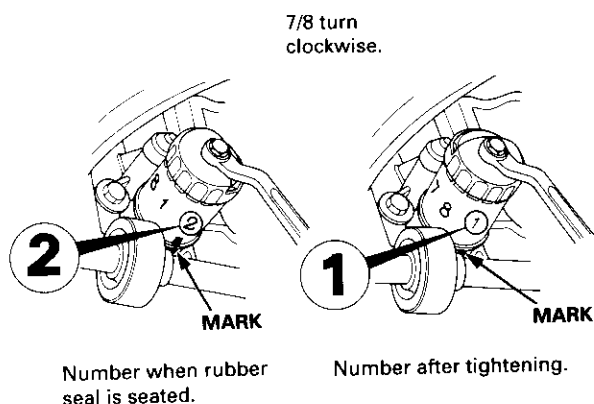

Number when rubber seal is seated	1	2	3	4	5	6	7	8
Number after tightening	8	1	2	3	4	5	6	7

CAUTION: Using any procedure other than those shown could result in serious engine damage due to oil leakage.

5. After installation, fill the engine with oil up to the specified level, run the engine for more than three minutes, then check for oil leakage.

Testing

If the oil pressure warning light stays on with the engine running, check the engine oil level. If the oil level is correct:

1. Connect a tachometer.
2. Remove the engine oil pressure switch, and install an oil pressure gauge.

ENGINE OIL PRESSURE SWITCH MOUNTING HOLE

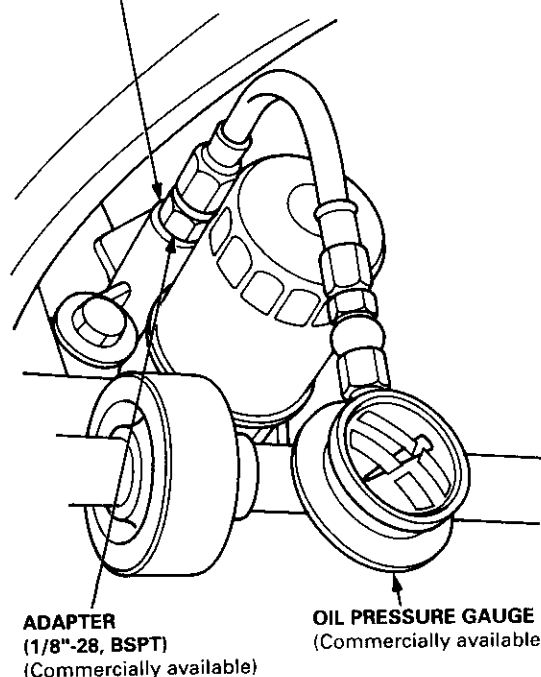

3. Start the engine. Shut it off immediately if the gauge registers no oil pressure. Repair the problem before continuing.
4. Allow the engine to reach operating temperature (fan comes on at least twice). The pressure should be:

Engine Oil Temperature: 176°F (80°C)

Engine Oil Pressure:

At Idle: 69 kPa (0.7 kgf/cm², 10 psi) minimum

At 3,000 rpm: 340 kPa (3.5 kgf/cm², 50 psi) minimum

- If the oil pressure is within specifications, replace the oil pressure switch and recheck.
- If the oil pressure is NOT within specifications, inspect the oil pump (see page 8-10).

Oil Jet (B16A2 engine)

Inspection

1. Remove the oil jet (see page 8-3) and inspect it as follows.
 - Make sure that a 1.1 mm (0.04 in) diameter drill will go through the nozzle hole (1.2 mm (0.05 in) diameter).
 - Insert the other end of the same 1.1 mm (0.04 in) drill into the oil intake (1.2 mm (0.05 in) diameter).
 - Make sure the check ball moves smoothly and has a stroke of approximately 4.0 mm (0.16 in).
 - Check the oil jet operation with an air nozzle. It should take at least 200 kPa (2.0 kgf/cm², 28 psi) to unseat the check ball.

NOTE: Replace the oil jet assembly if the nozzle is damaged or bent.

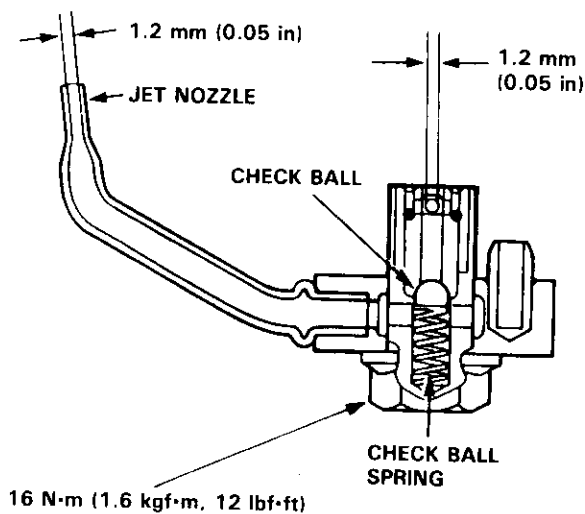

2. Mounting torque is critical. Be very precise when installing.

Torque: 16 N·m (1.6 kgf·m, 12 lbf·ft)



Oil Pump

Overhaul

NOTE:

- Use new O-rings when reassembling.
- Apply oil to O-rings before installation.
- Use liquid gasket, Part No. 08718 - 0001 or 08718 - 0003.
- The rotors must be installed to the same direction in order.
- After reassembly, check that the rotors move without binding.

B16A2 engine:

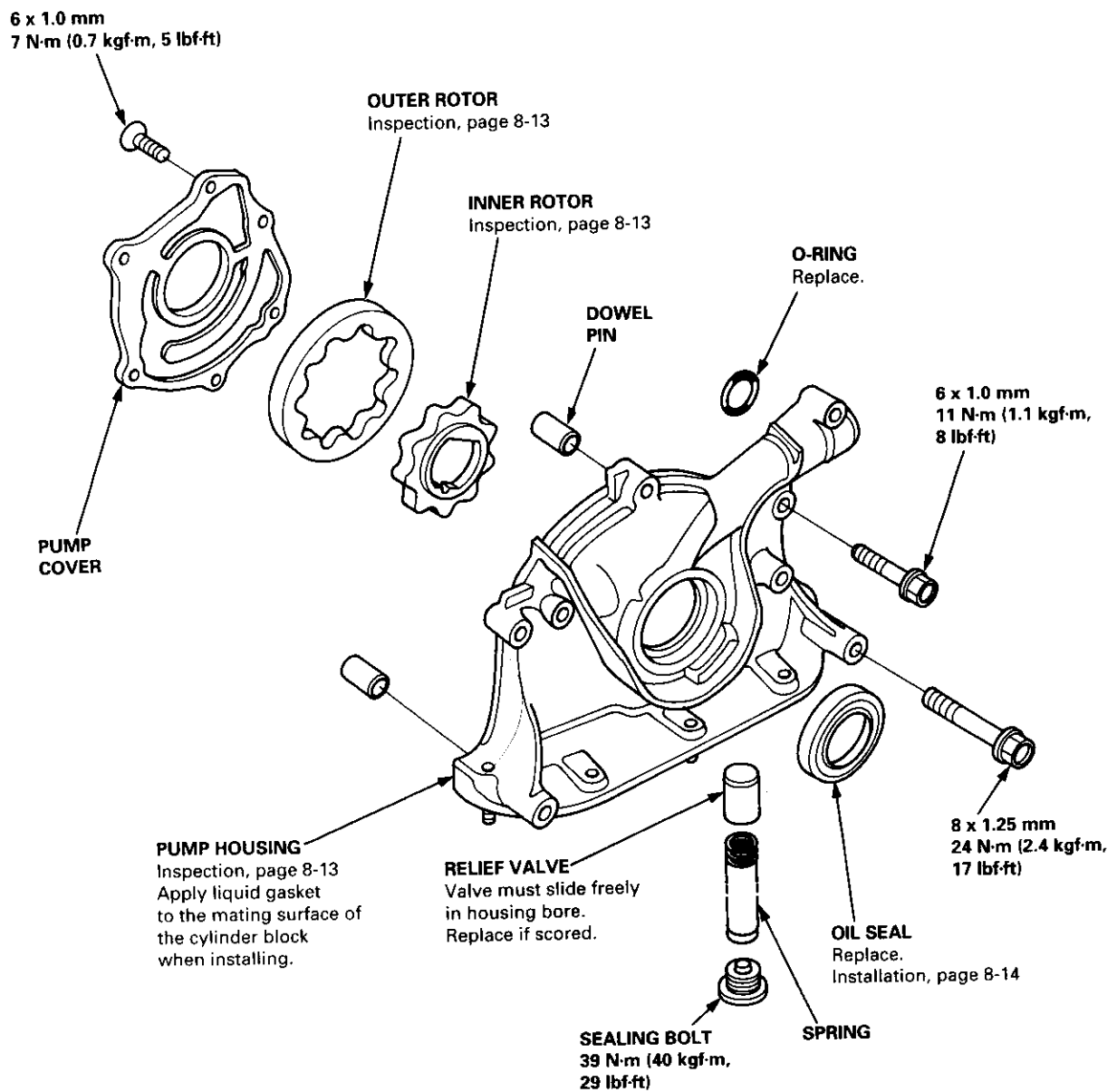

(cont'd)

Oil Pump

Overhaul (cont'd)

NOTE:

- Use new O-rings when reassembling.
- Apply oil to O-rings before installation.
- Use liquid gasket, Part No. 08718 - 0001 or 08718 - 0003.
- The rotors must be installed to the same direction.
- After reassembly, check that the rotors move without binding.

D16Y5, D16Y7, D16Y8 engines:

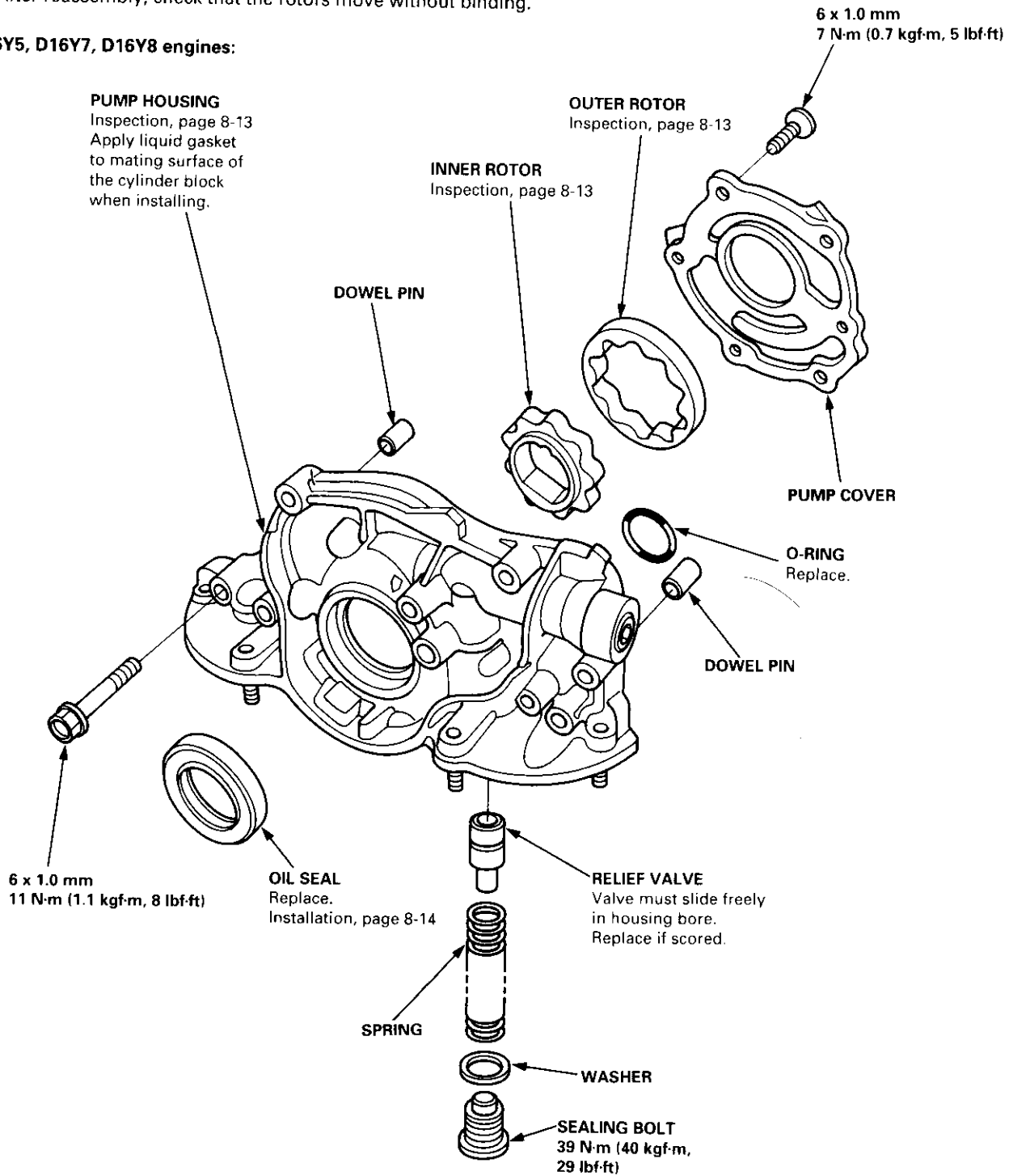



Removal/Inspection/Installation

1. Drain the engine oil.
2. Turn the crankshaft and align the white groove on the crankshaft pulley with the pointer on the lower cover.
3. Remove the cylinder head cover and upper cover.
4. Remove the power steering pump belt, air conditioner belt and the alternator belt.
5. Remove the crankshaft pulley and remove the lower cover.
6. Remove the timing belt.
7. Remove the drive pulley.
8. Remove the oil pan and oil screen.

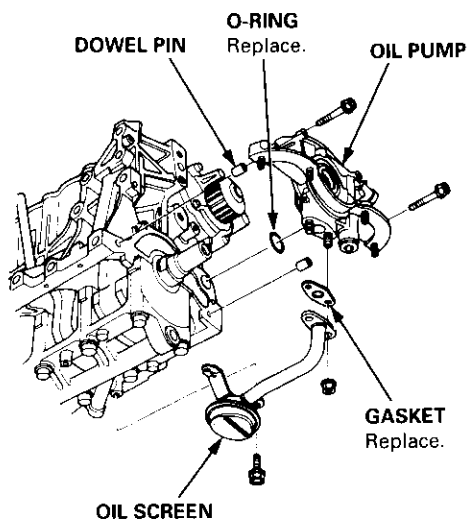

9. Remove the oil pump.

10. Remove the screws from the pump housing, then separate the housing and cover.
11. Check the inner-to-outer rotor radial clearance on the pump rotor. If the inner-to-outer rotor clearance exceeds the service limit, replace the inner and outer rotors.

Inner Rotor-to-Outer Rotor Radial Clearance

Standard (New): B16A2 engine 0.04 – 0.16 mm
(0.002 – 0.006 in)

D16Y5, D16Y7, D16Y8 engines

0.02 – 0.14 mm (0.001 – 0.006 in)

Service Limit: 0.20 mm (0.008 in)

OUTER ROTOR

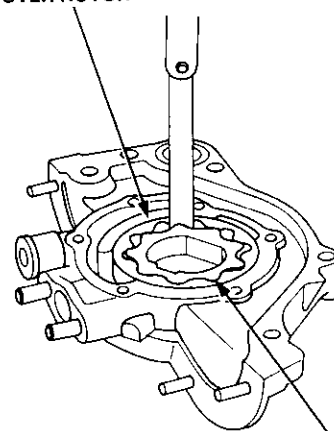

INNER ROTOR

12. Check the housing-to-rotor axial clearance on the pump rotor. If the housing-to-rotor axial clearance exceeds the service limit, replace the set of inner and outer rotors and/or the pump housing.

Housing-to-Rotor Axial Clearance

Standard (New): B16A2 engine 0.02 – 0.07 mm
(0.001 – 0.003 in)

D16Y5, D16Y7, D16Y8 engines

0.03 – 0.08 mm (0.001 – 0.003 in)

Service Limit: 0.15 mm (0.006 in)

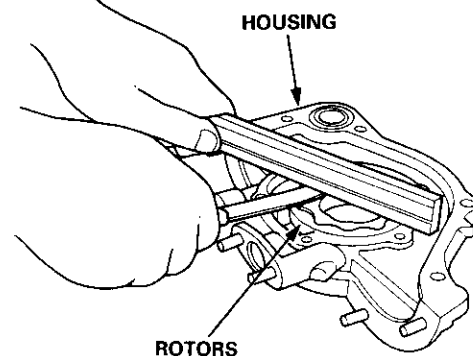

ROTORS

(cont'd)

Oil Pump

Removal/Inspection/Installation (cont'd)

13. Check the housing-to-outer rotor radial clearance. If the housing-to-outer rotor radial clearance exceeds the service limit, replace the set of inner and outer rotors and/or the pump housing.

Housing-to-Outer Rotor Radial Clearance:

Standard (New): B16A2 engine 0.10 – 0.19 mm
(0.004 – 0.007 in)
D16Y5, D16Y7, D16Y8 engines
0.10 – 0.18 mm (0.004 – 0.007 in)
Service Limit: 0.20 mm (0.008 in)

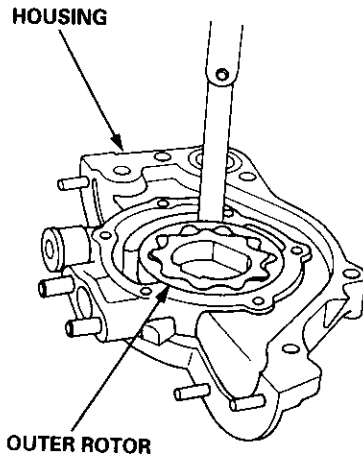

14. Inspect both rotors and pump housing for scoring or other damage. Replace parts if necessary.
15. Remove the old oil seal from the oil pump.
16. Using the special tool, gently tap in the new oil seal until the driver bottoms against the pump.

NOTE: The oil seal alone can be replaced without removing the oil pump.

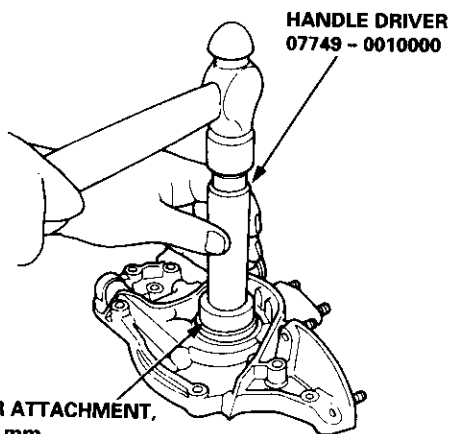

17. Reassemble the oil pump, applying thread lock to the pump housing screws.
18. Check that the oil pump turns freely.
19. Apply a light coat of oil to the seal lip.
20. Install the two dowel pins and new O-ring on the oil pump.
21. Apply liquid gasket to the cylinder block mating surface of the oil pump.

NOTE:

- Use liquid gasket, Part No. 08718 - 0001 or 08718 - 0003.
- Check that the mating surfaces are clean and dry before applying liquid gasket.
- Apply liquid gasket evenly, in a narrow bead centered on the mating surface.
- To prevent leakage of oil, apply liquid gasket to the inner threads of the bolt holes.
- Do not install the parts if five minutes or more have elapsed since applying liquid gasket. Instead, reapply liquid gasket after removing the old residue.
- After assembly, wait at least 30 minutes before filling the engine with oil.

B16A2 engine:

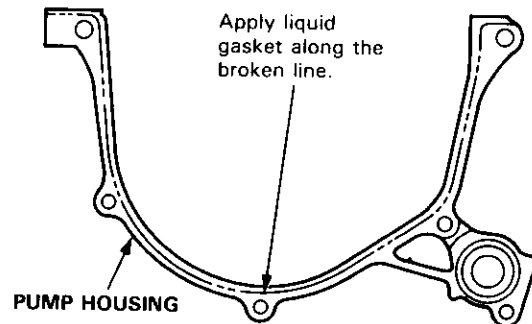

D16Y5, D16Y7, D16Y8 engines:

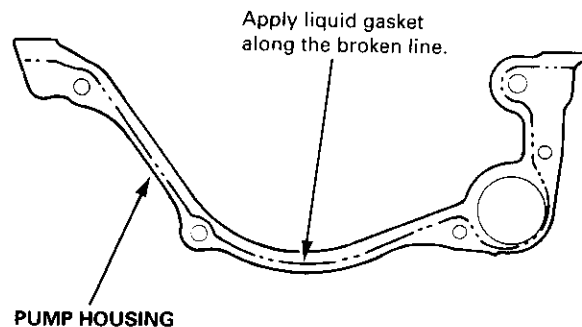



22. Install the oil pump on the cylinder block. Apply grease to the lip of the oil pump seal. Then, install the oil pump onto the crankshaft. When the pump is in place, clean any excess grease off the crankshaft and check that the oil seal lip is not distorted.

B16A2 engine:

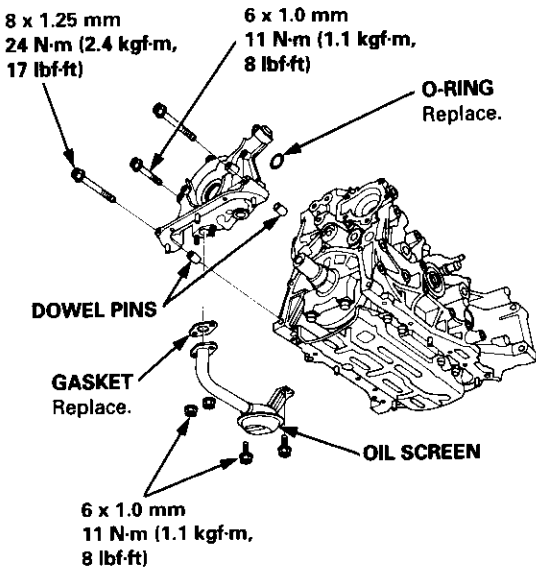

D16Y5, D16Y7, D16Y8 engines:

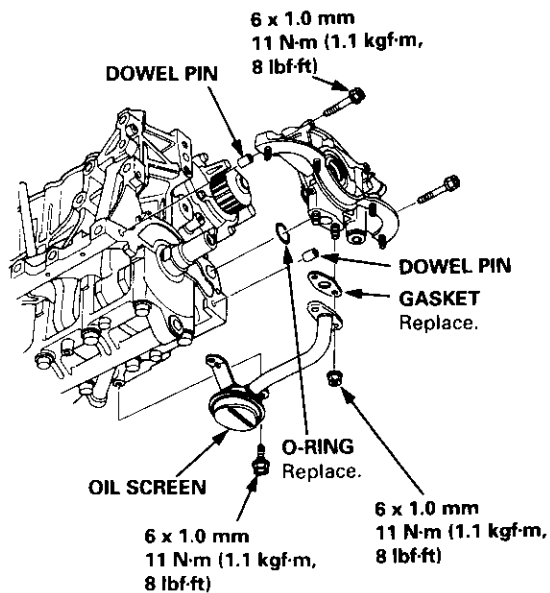

23. Install the oil screen.

24. Install the oil pan (see pages 7-26 or 7-27).

NOTE: Clean the oil pan gasket mating surfaces.

Intake Manifold/Exhaust System

Intake Manifold

Replacement 9-2

Exhaust Manifold

Replacement 9-6

Exhaust Pipe and Muffler

Replacement 9-9

Three Way Catalytic Converter (TWC)

Inspection 9-12

Heated Oxygen Sensor (HO2S)

Replacement 9-12



Intake Manifold

Replacement

NOTE: Use new O-rings and gaskets when reassembling.

CAUTION:

- Check for folds or scratches on the surface of the gasket.
- Replace with a new gasket if damaged.

D16Y7 engine:

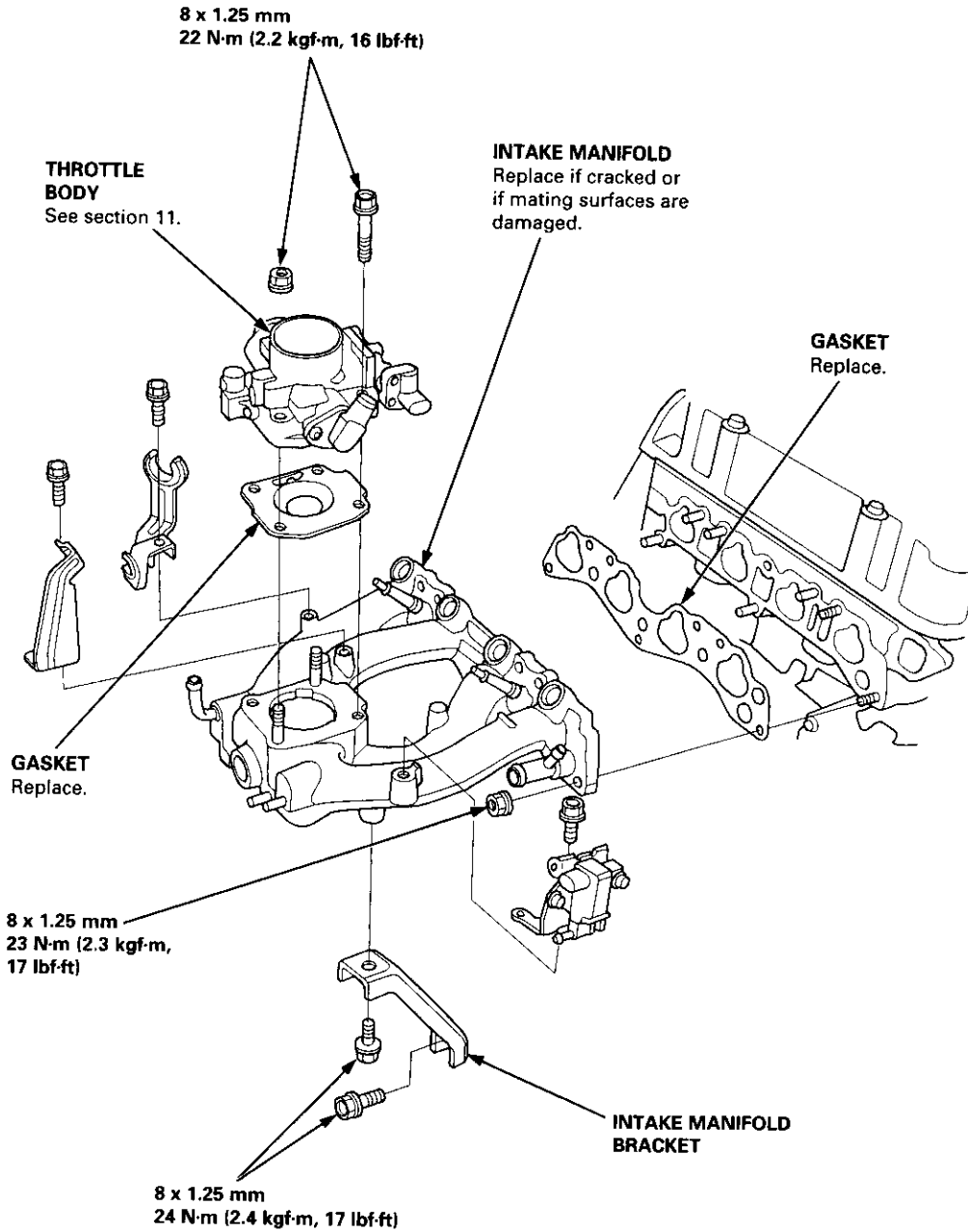



D16Y5 engine:

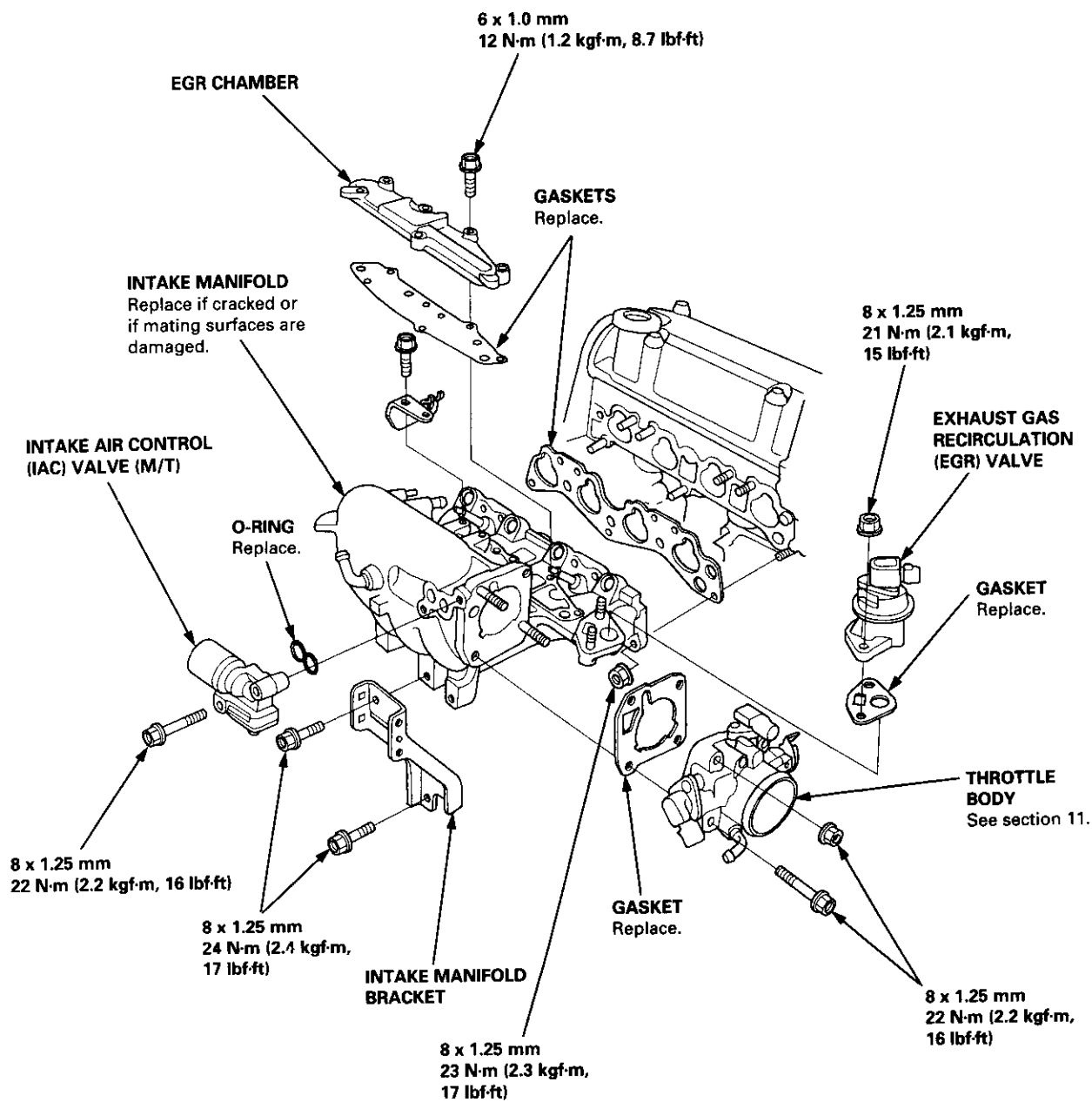

(cont'd)

Intake Manifold

Replacement (cont'd)

NOTE: Use new O-rings and gaskets when reassembling.

CAUTION:

- Check for folds or scratches on the surface of the gasket.
- Replace with a new gasket if damaged.

D16V8 engine:

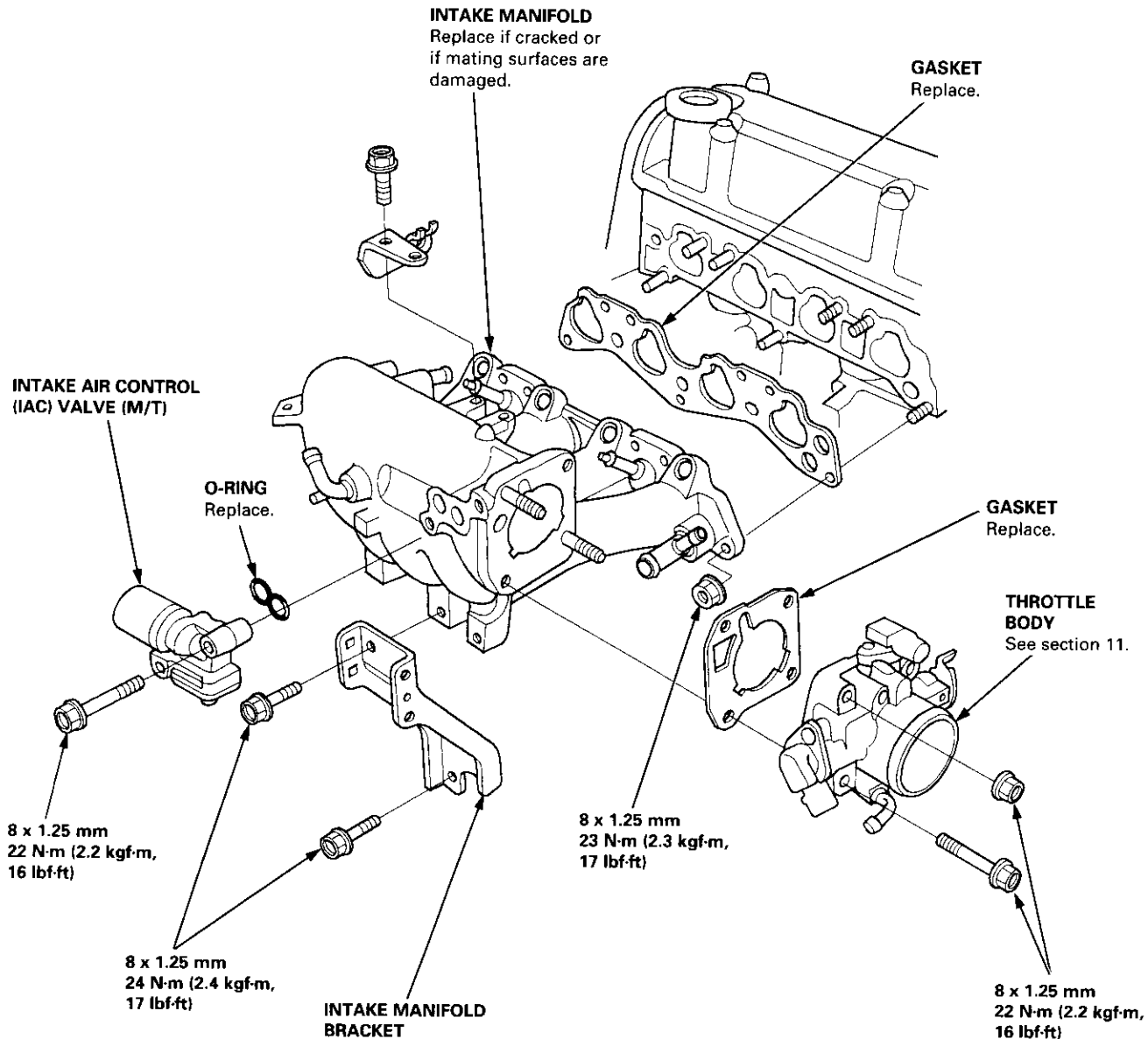



B16A2 engine:

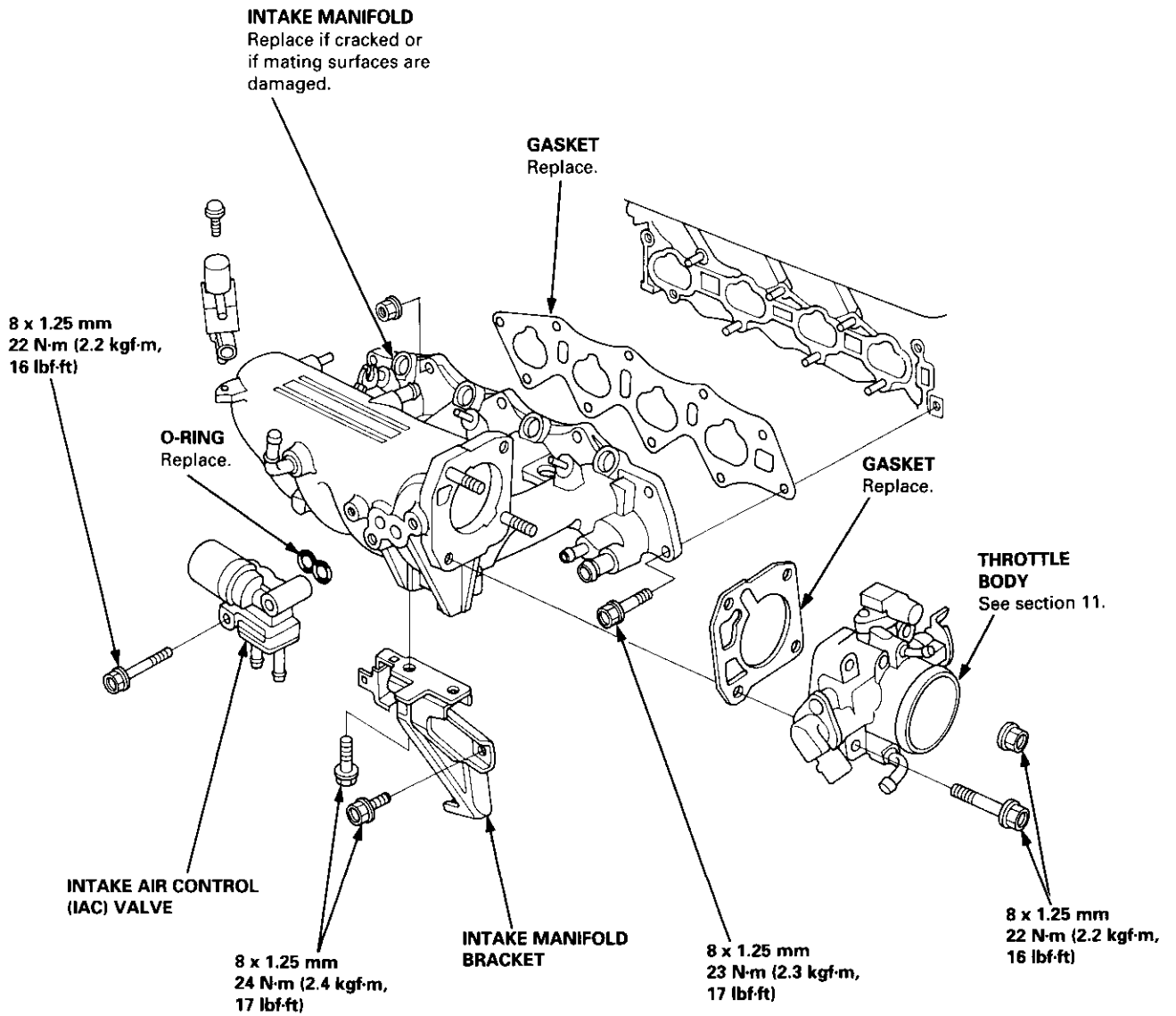

Exhaust Manifold

Replacement

NOTE: Use new gaskets and self-locking nuts when reassembling.

CAUTION:

- Check for folds or scratches on the surface of the gasket.
- Replace with a new gasket if damaged.

D16Y5, D16Y7 engines:

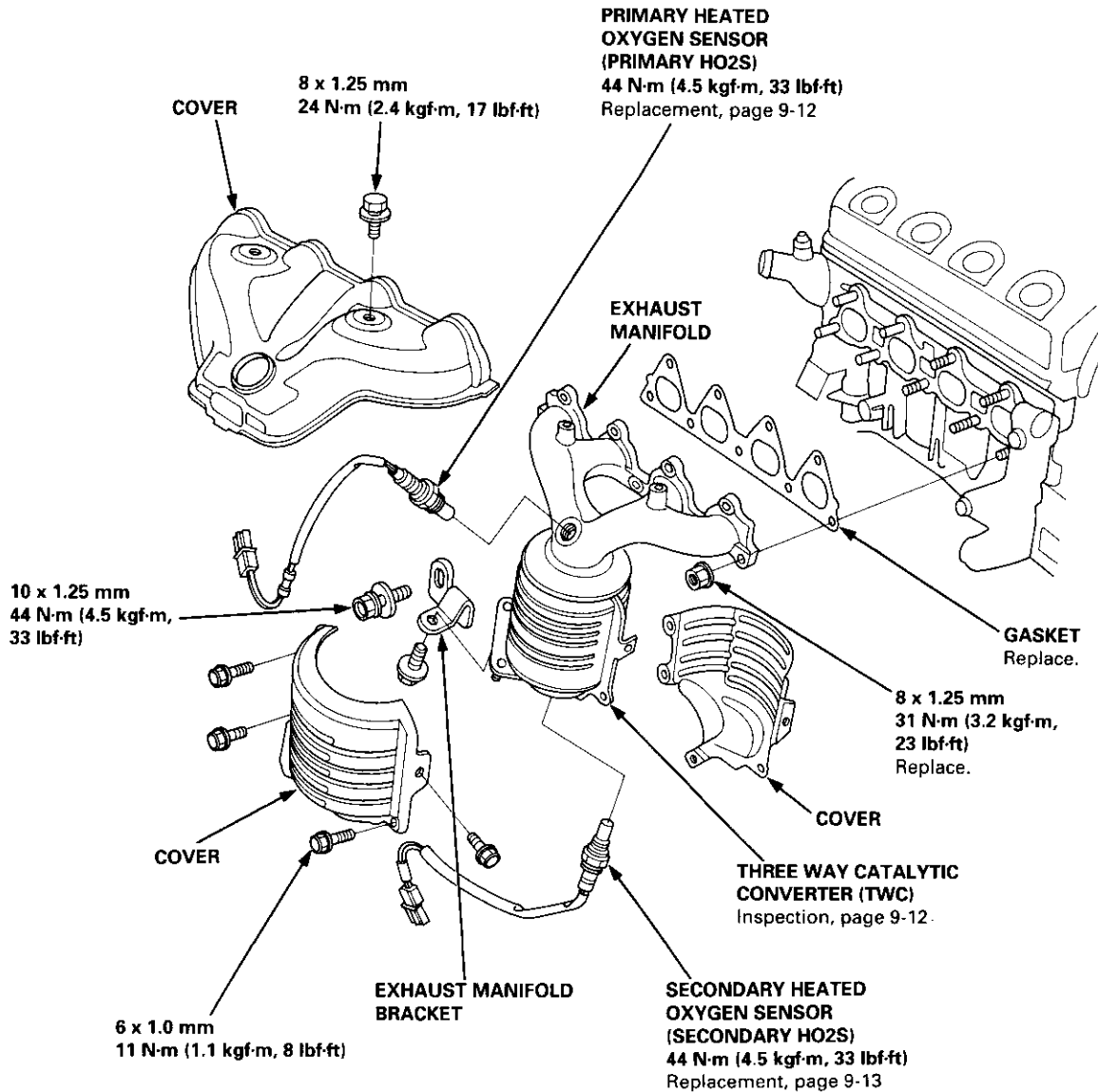



D16Y8 engine:

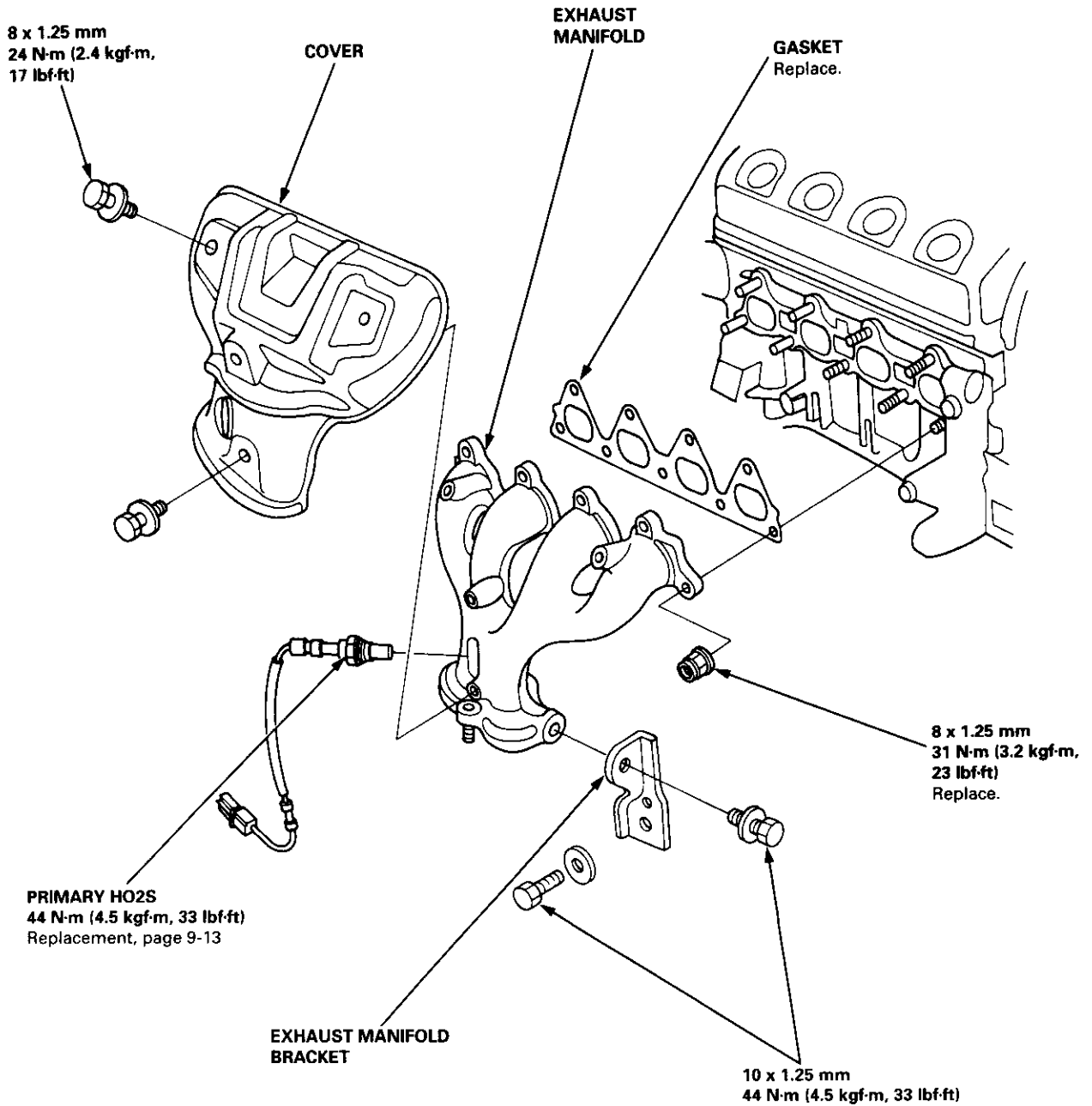

(cont'd)

Exhaust Manifold

Replacement (cont'd)

NOTE: Use new gaskets and self-locking nuts when reassembling.

CAUTION:

- Check for folds or scratches on the surface of the gasket.
- Replace with a new gasket if damaged.

B16A2 engine:

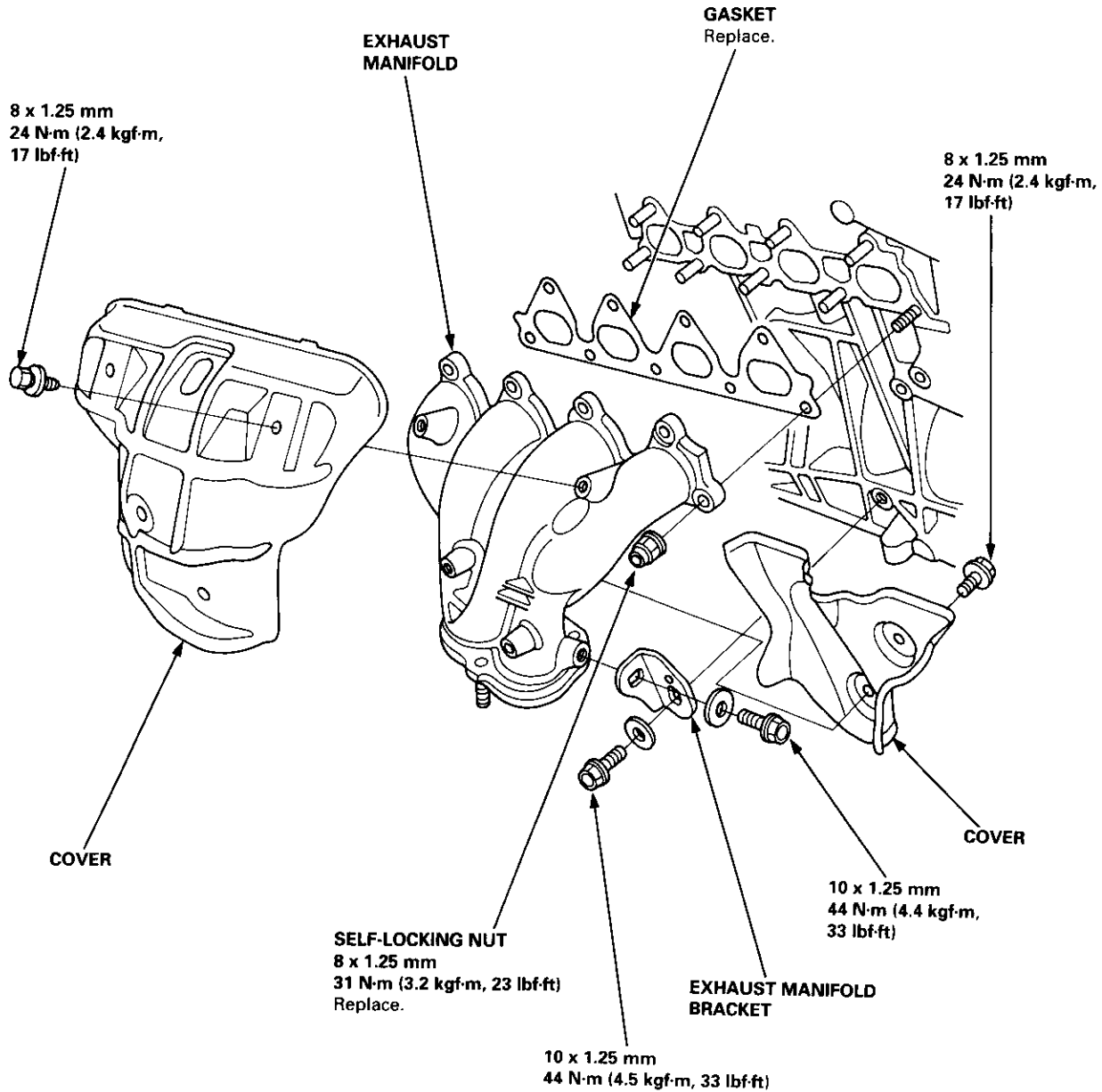



Exhaust Pipe and Muffler

Replacement

NOTE: Use new gaskets and self-locking nuts when reassembling.

D16Y5, D16Y7 engines:

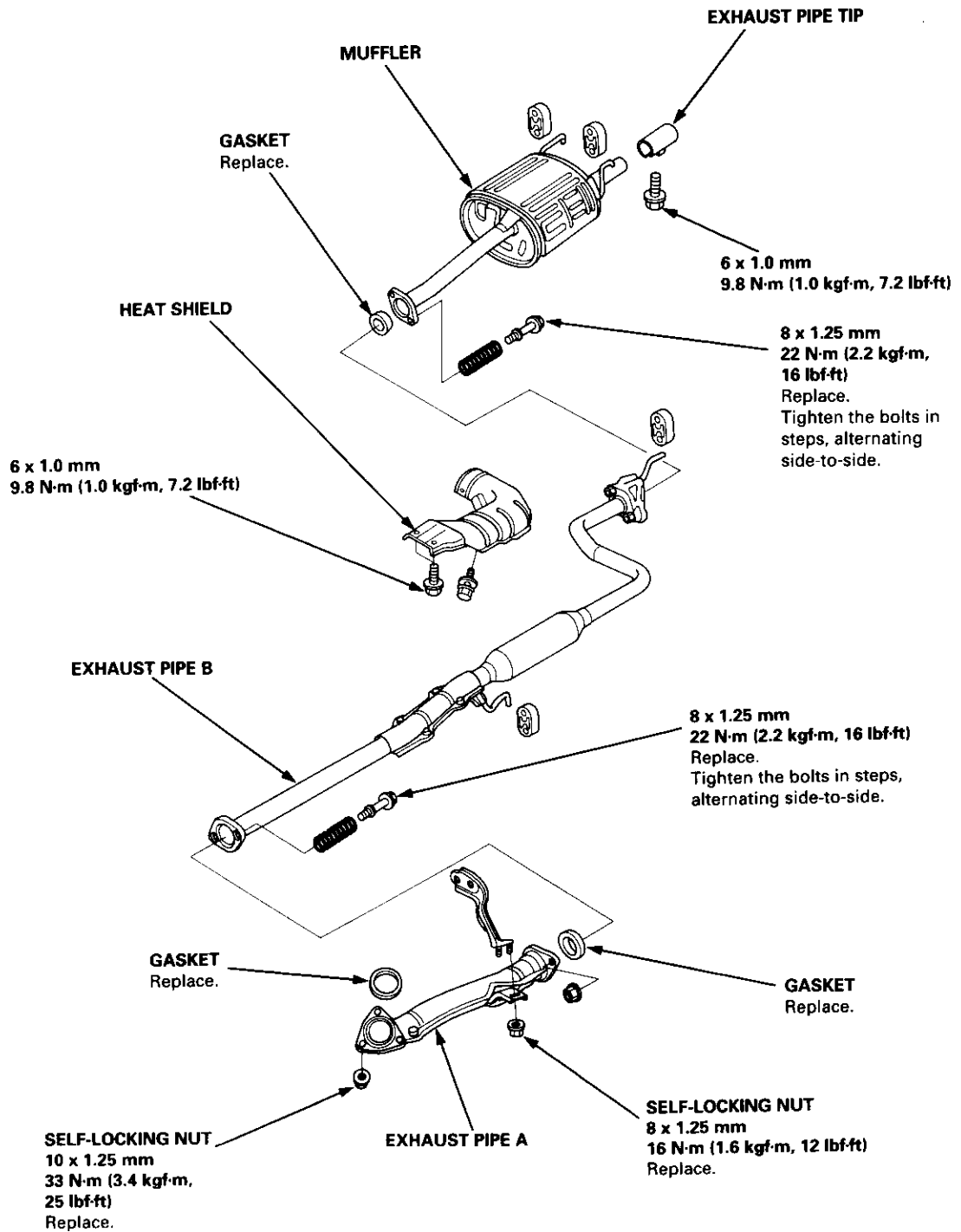

(cont'd)

Exhaust Pipe and Muffler

Replacement (cont'd)

NOTE: Use new gaskets and self-locking nuts when reassembling.

D16Y8 engine:

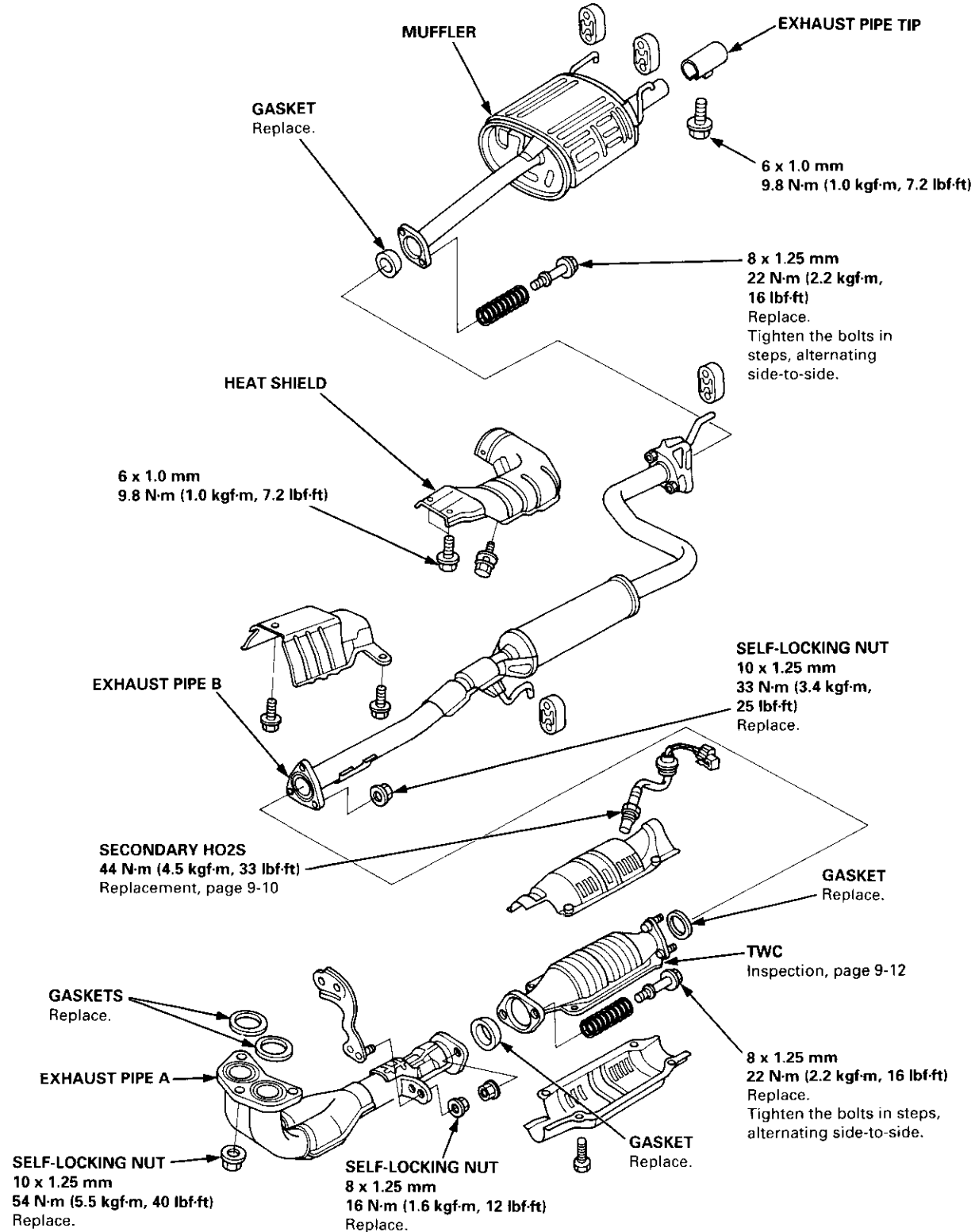



B16A2 engine:

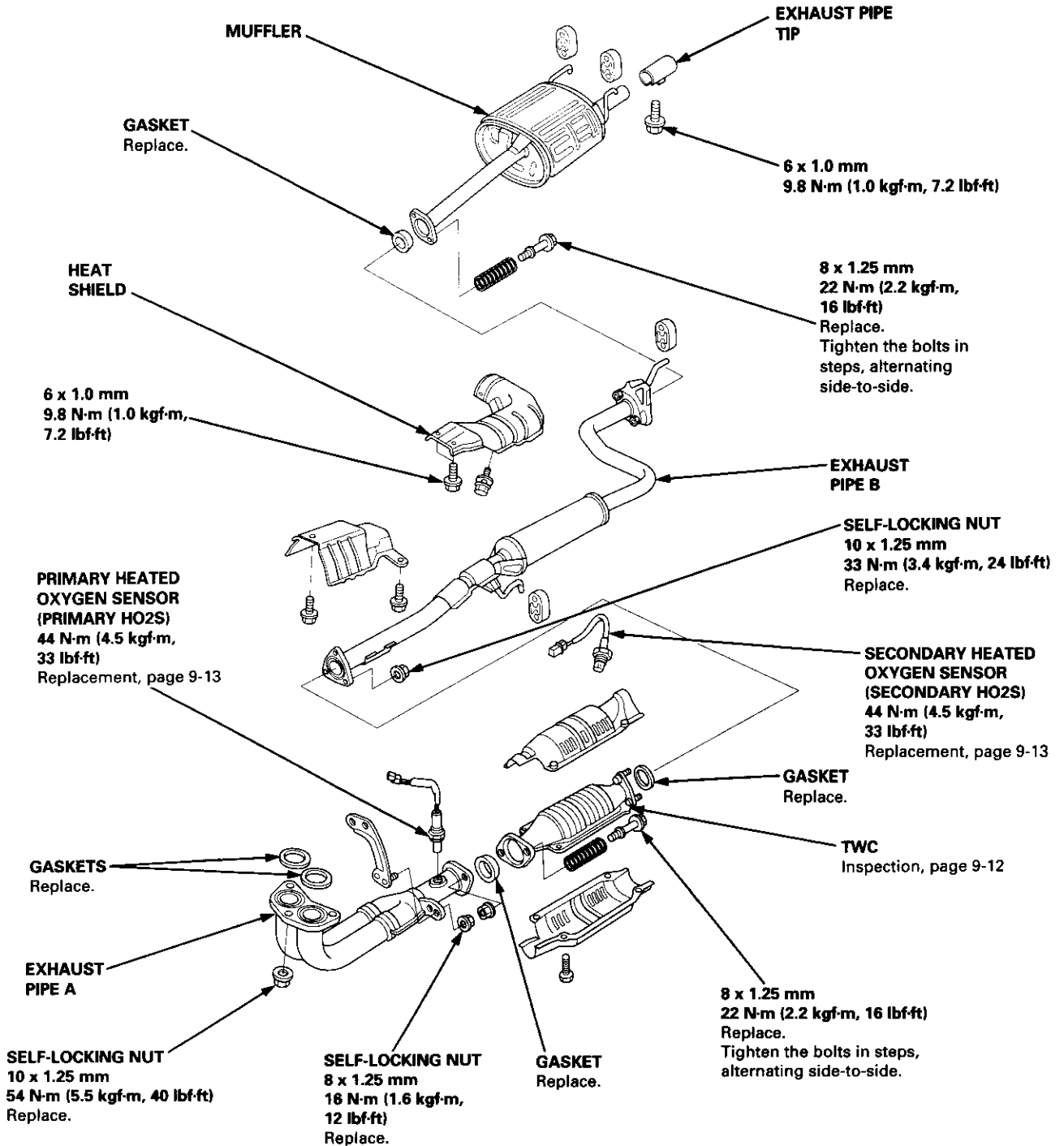

Inspection

- Using a flashlight, make a visual check for plugging, melting and cracking of the catalyst.

D16Y5, D16Y7 engines:

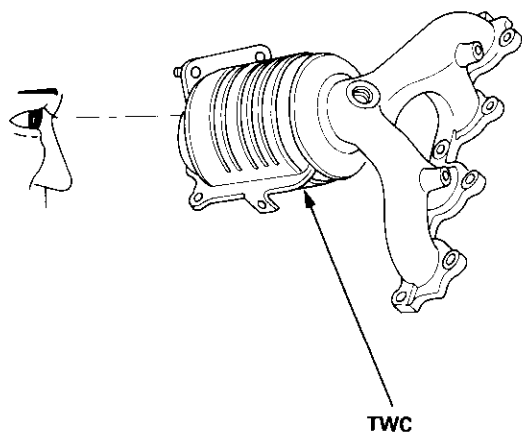

B16A2, D16Y8 engines:

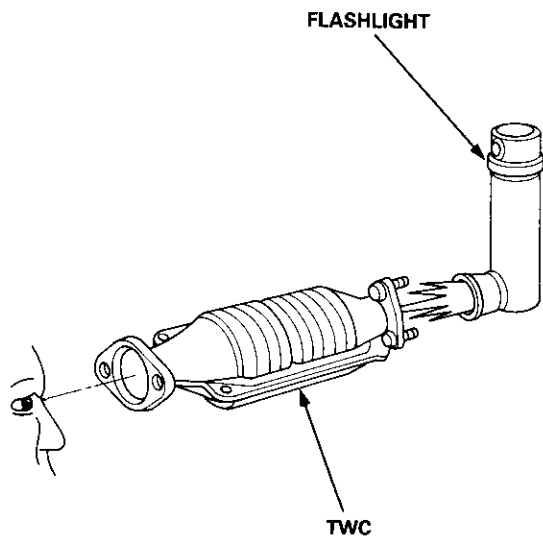

Replacement

Primary HO2S:

- Remove the primary HO2S.

D16Y5, D16Y7 engines:

- Disconnect the primary HO2S connector, then remove the cover.

8 x 1.25 mm
24 N·m (2.4 kgf·m,
17 lbf·ft)

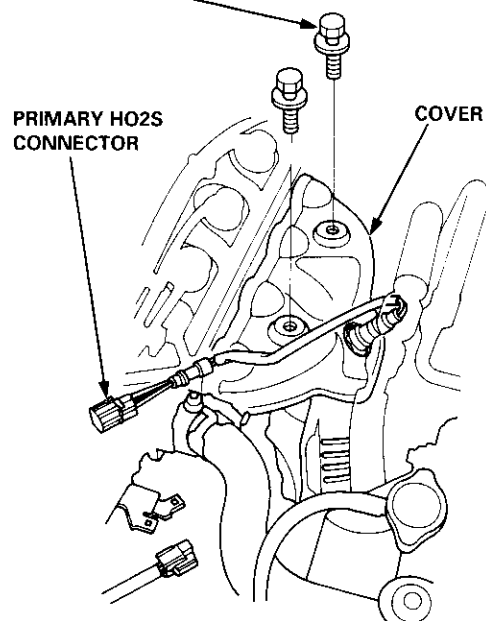

- Remove the primary HO2S.

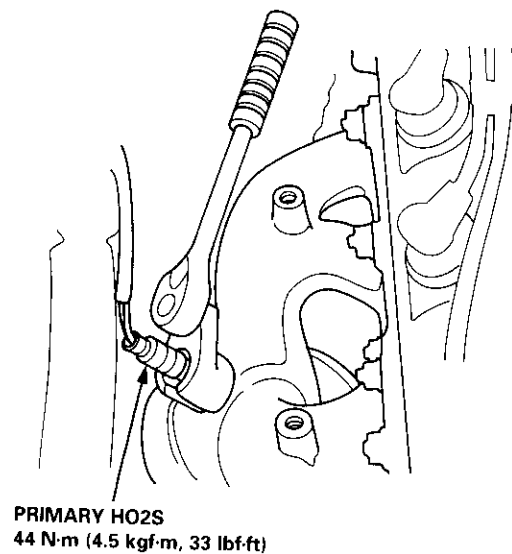



B16A2, D16Y8 engines:

- a. Disconnect the primary HO2S connector then remove the primary HO2S.

B16A2 engine

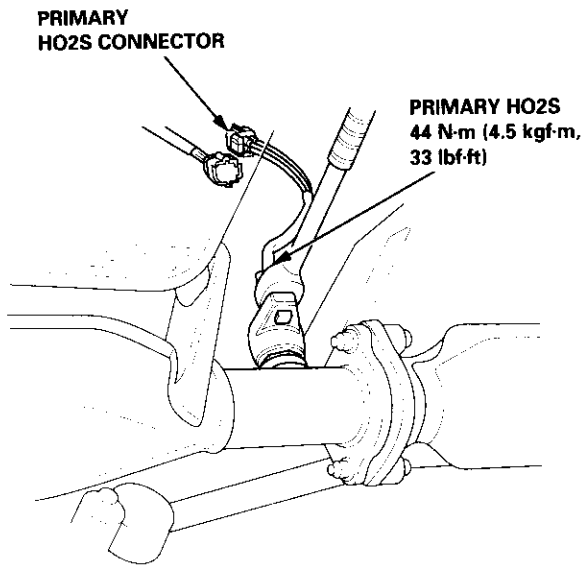

D16Y8 engine

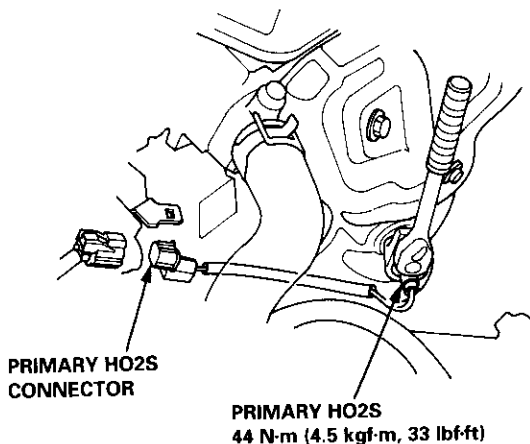

- 2. Install the primary HO2S in reverse order of removal.

Secondary HO2S:

- 1. Remove the secondary HO2S.

D16Y5, D16Y7 engines:

- a. Disconnect the secondary HO2S connector, then remove the secondary HO2S.

**O2 SENSOR
WRENCH**
(Commercially available)

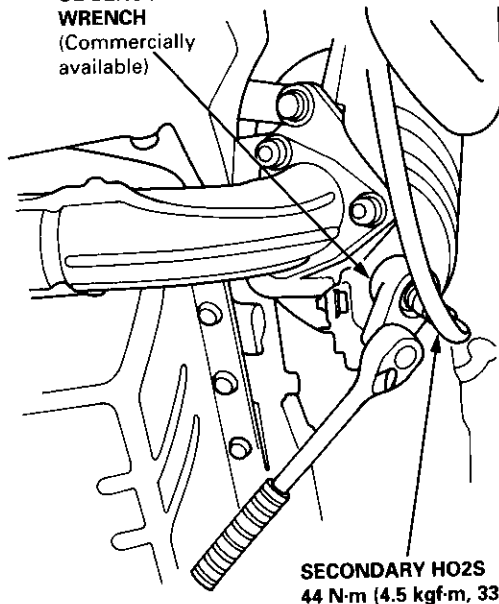

B16A2, D16Y8 engines:

- a. Remove the grommet, and pull out the secondary HO2S connector, then disconnect the secondary HO2S connector.

**SECONDARY HO2S
CONNECTOR**

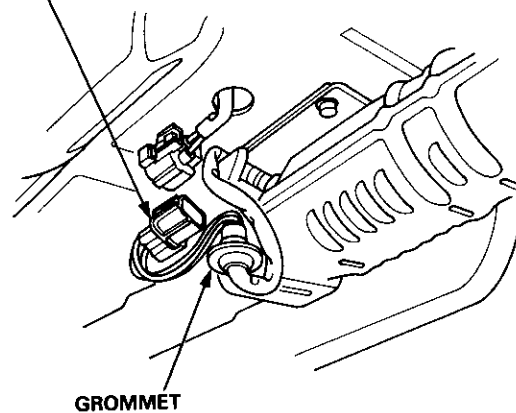

(cont'd)

HO2S

Replacement (cont'd)

- b. Remove the secondary HO2S.

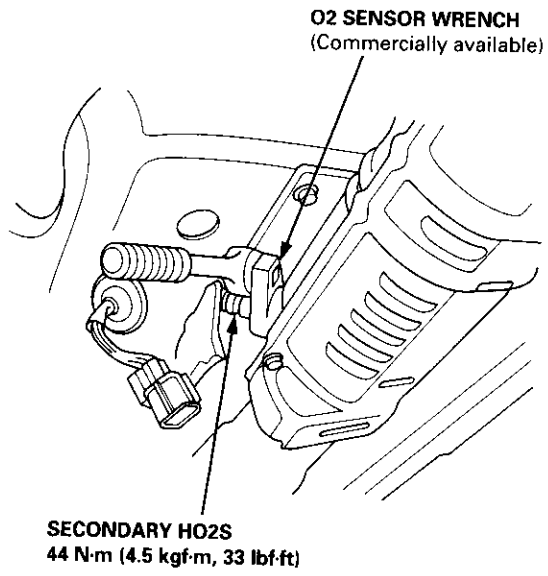

2. Install the secondary HO2S in reverse order of removal.

Cooling

Illustrated Index	10-2
Radiator	
Replacement	10-6
Engine Coolant Refilling and Bleeding	10-7
Cap Testing	10-9
Testing	10-9
Thermostat	
Replacement	10-10
Testing	10-10
Engine Coolant Temperature (ECT) Switch	
Testing	10-11
Water Pump	
Illustrated Index	10-12
Inspection	10-14
Replacement	10-14



Illustrated Index

WARNING System is under high pressure when the engine is hot. To avoid danger of releasing scalding engine coolant, remove the cap only when the engine is cool.

Total Cooling System Capacity (Including heater and reservoir (0.4 l (0.42 US qt, 0.35 Imp qt))):

M/T	4.2 l (4.4 US qt, 3.7 Imp qt)* ¹ 5.0 l (5.3 US qt, 4.4 Imp qt)* ²
A/T	4.1 l (4.3 US qt, 3.6 Imp qt)* ³ 4.3 l (4.5 US qt, 3.8 Imp qt)* ⁴
CVT	4.3 l (4.5 US qt, 3.8 Imp qt)

*1: D16Y5, D16Y7, D16Y8 engines

*2: B16A2 engine

*3: D16Y7 engine

*4: D16Y8 engine

CAUTION: If any engine coolant spills on painted portions of the body, rinse it off immediately.

NOTE:

- Check all cooling system hoses for damage, leaks or deterioration and replace if necessary.
- Check all hose clamps and retighten if necessary.
- Use new O-rings when reassembling.

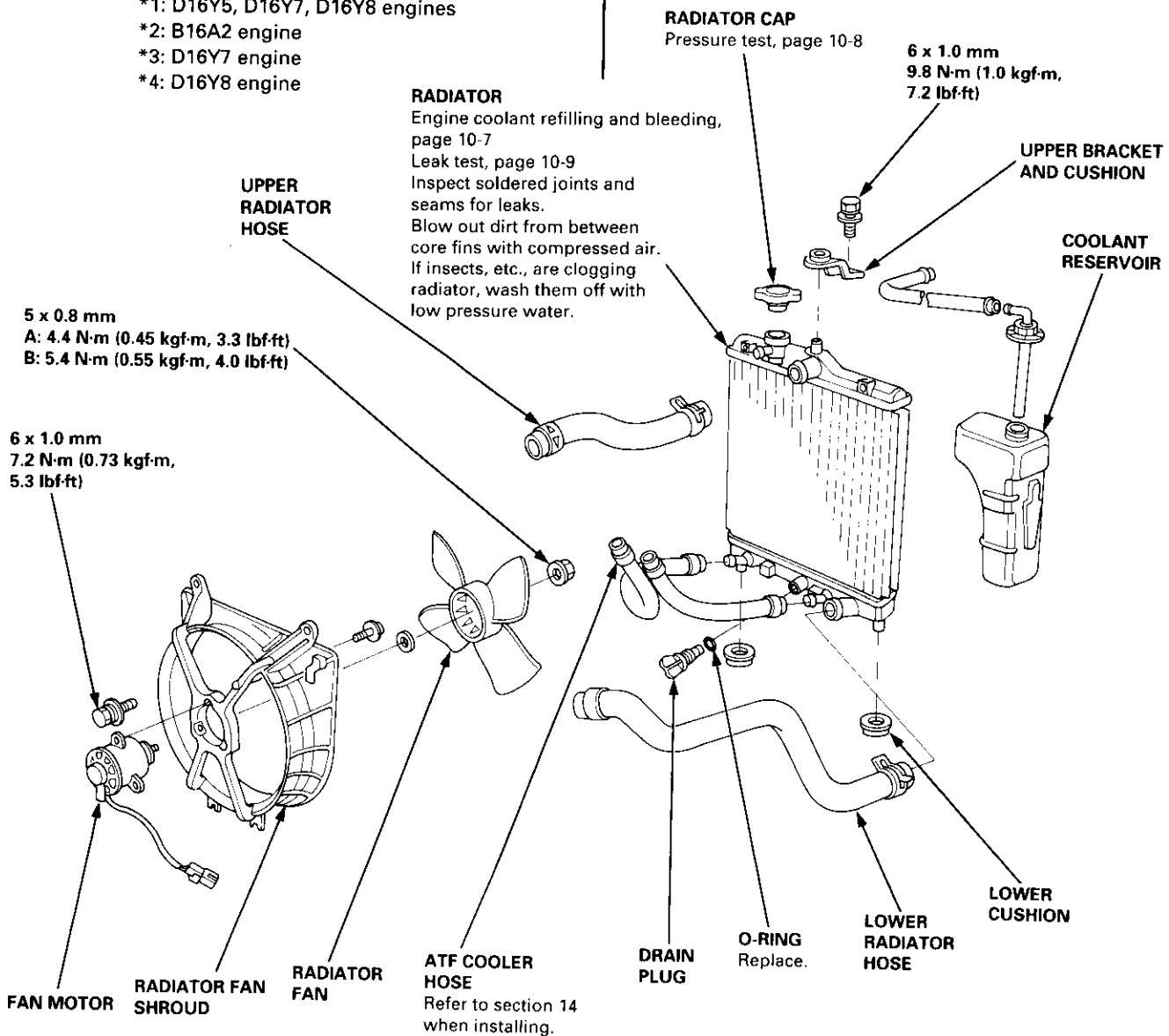

A: TOYO RADIATOR manufactured radiator
B: NIPPONDENSO manufactured radiator



**Engine Hose Connections:
D16Y7 engine:**

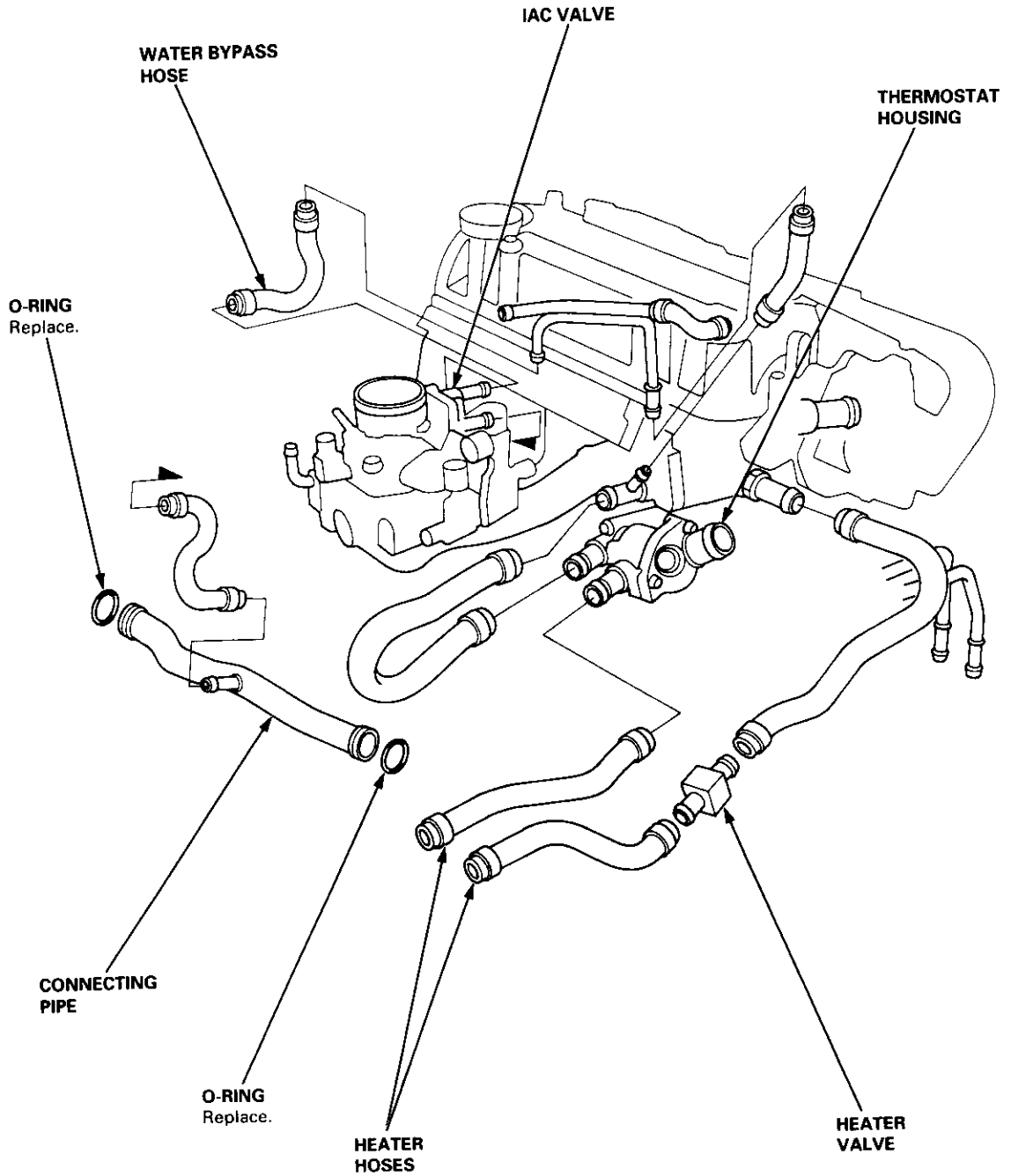

(cont'd)

Illustrated Index

(cont'd)

Engine Hose Connections:

D16Y5, D16Y8 engines:

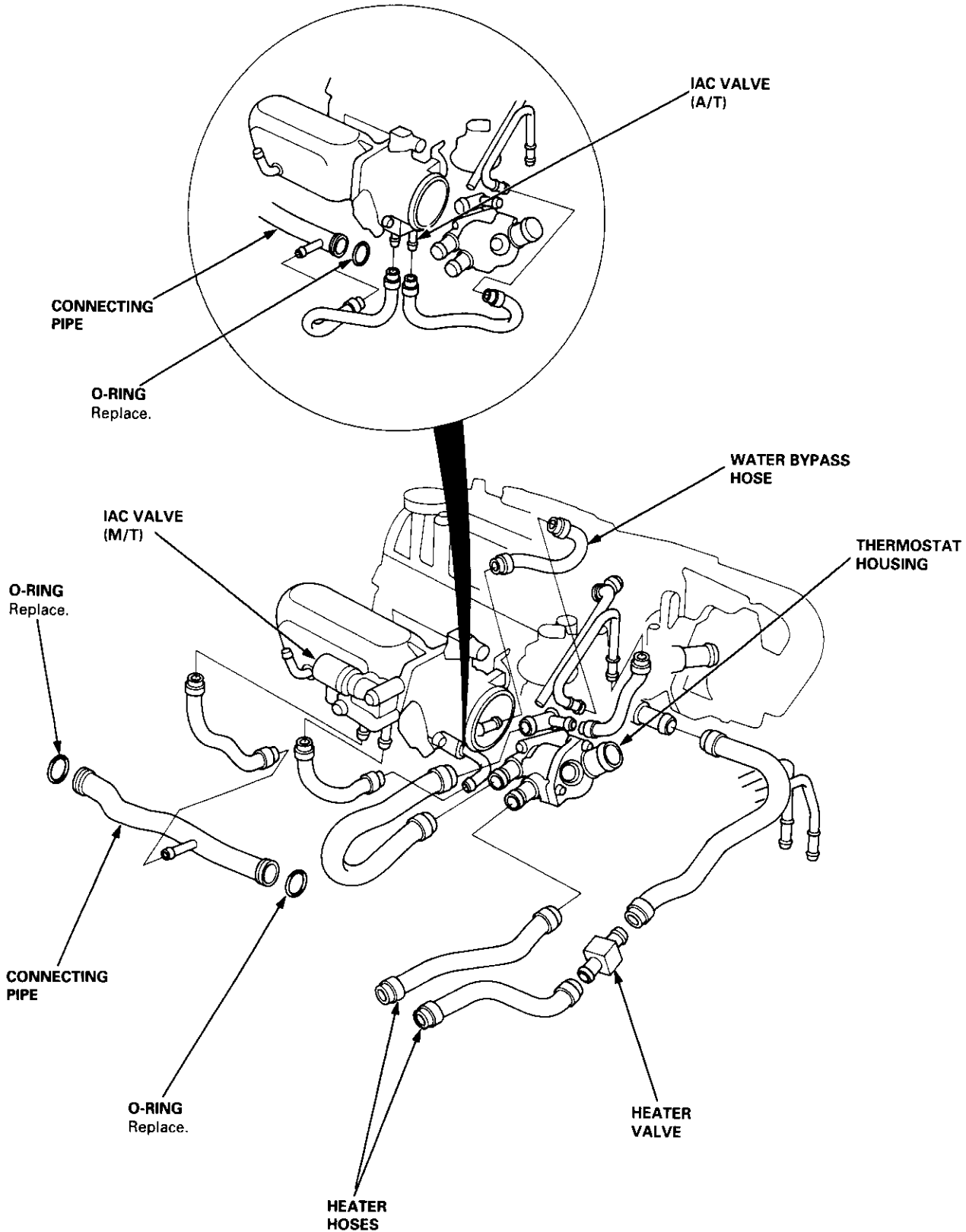



**Engine Hose Connections:
B16A2 engine:**

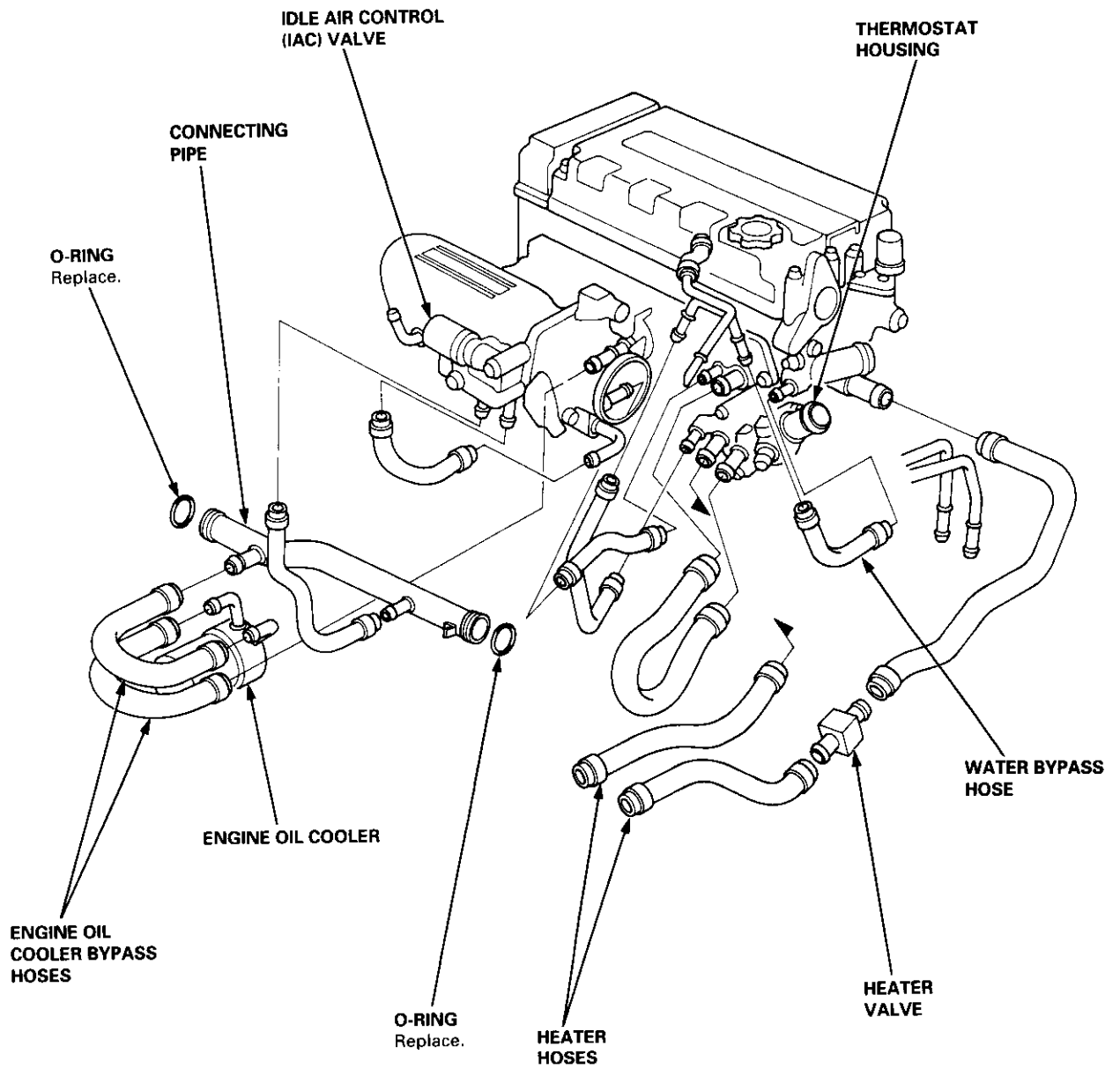

Radiator

Replacement

1. Drain the engine coolant.
2. Remove the upper and lower radiator hoses, and ATF cooler hoses.
3. Disconnect the fan motor connector.
4. Remove the radiator upper bracket, then pull up the radiator.

5. Remove the fan shroud assemblies and other parts from the radiator.

Install the radiator in the reverse order of removal:

NOTE:

- Set the upper and lower cushions securely.
- Fill the radiator with engine coolant and bleed the air.

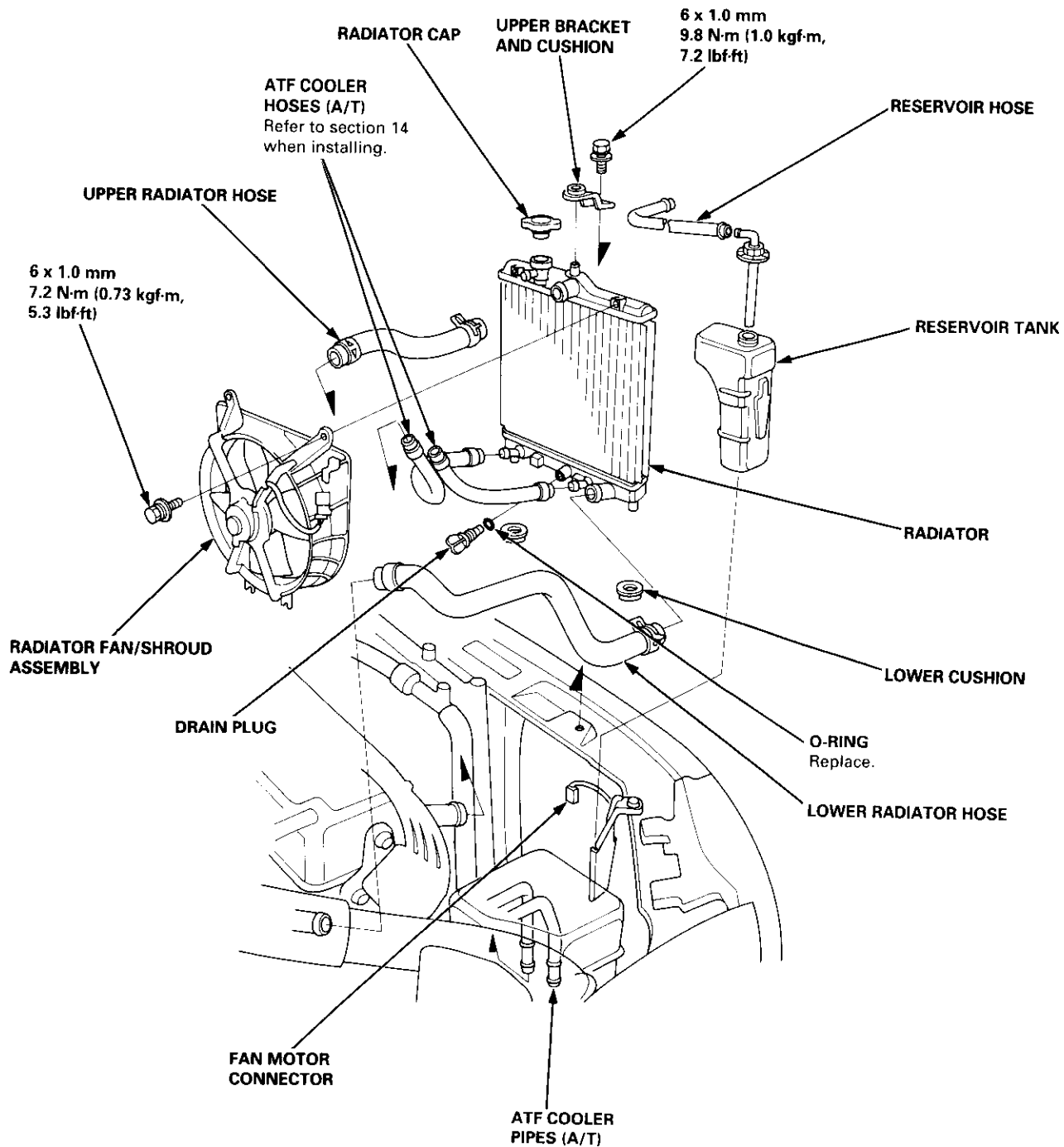



Engine Coolant Refilling and Bleeding

CAUTION: When pouring engine coolant, be sure to shut the relay box lid and not to let coolant spill on the electrical parts or the paint. If any coolant spills, rinse it off immediately.

1. Slide the heater temperature control lever to maximum heat. Make sure the engine and radiator are cool to the touch.
2. Remove the radiator cap.
3. Loosen the drain plug, and drain the coolant.

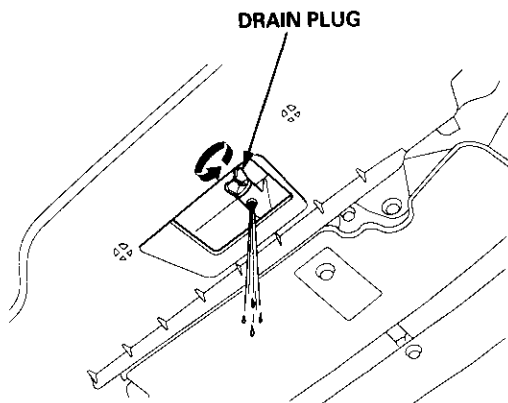

4. Remove the drain bolt from the cylinder block.

D16Y5, D16Y7, D16Y8 engines:

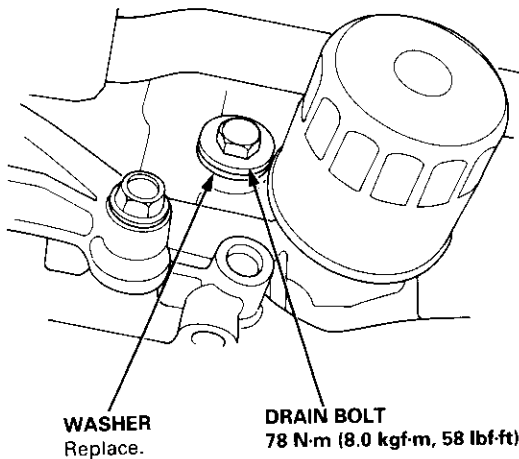

B16A2 engine:

WASHER
Replace.

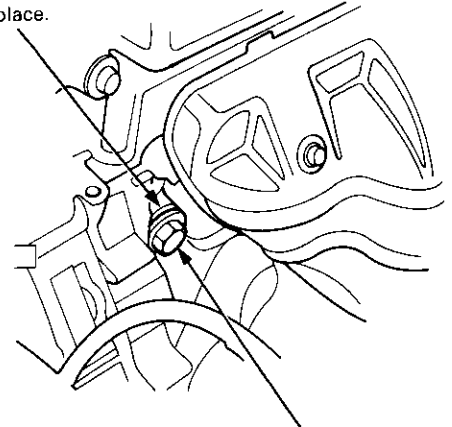

DRAIN BOLT
78 N-m (8.0 kgf-m, 58 lbf-ft)

5. Apply liquid gasket to the drain bolt threads, then reinstall the bolt with a new washer and tighten it securely.
6. Tighten the radiator drain plug securely.
7. Remove, drain and reinstall the reservoir. Fill the tank halfway to the MAX mark with water, then up to the MAX mark with antifreeze.

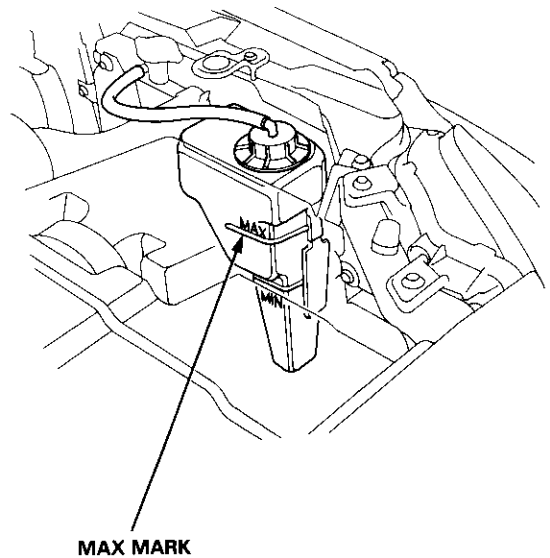

(cont'd)

Radiator

Engine Coolant Refilling and Bleeding (cont'd)

- Mix the recommended antifreeze with an equal amount of water in a clean container.

NOTE:

- Use only genuine Honda antifreeze/coolant.
- For best corrosion protection, the coolant concentration must be maintained year-round at 50% minimum. Coolant concentrations less than 50% may not provide sufficient protection against corrosion or freezing.
- Coolant concentrations greater than 60% will impair cooling efficiency and are not recommended.

CAUTION:

- Do not mix different brands of antifreeze/coolants.
- Do not use additional rust inhibitors or anti-rust products; they may not be compatible with the coolant.

Engine Coolant Refill Capacity [including reservoir (0.4 l (0.42 US qt, 0.35 Imp qt))]:

M/T	3.8 l (4.0 US qt, 3.3 Imp qt)* ¹ 4.5 l (4.8 US qt, 4.0 Imp qt)* ²
A/T	3.7 l (3.9 US qt, 3.3 Imp qt)* ³ 3.9 l (4.1 US qt, 3.4 Imp qt)* ⁴
CVT	3.9 l (4.1 US qt, 3.4 Imp qt)

*1: D16Y5, D16Y7, D16Y8 engines

*2: B16A2 engine

*3: D16Y7 engine

*4: D16Y8 engine

- Pour coolant into the radiator up to the base of the filler neck, and install the radiator cap loosely.

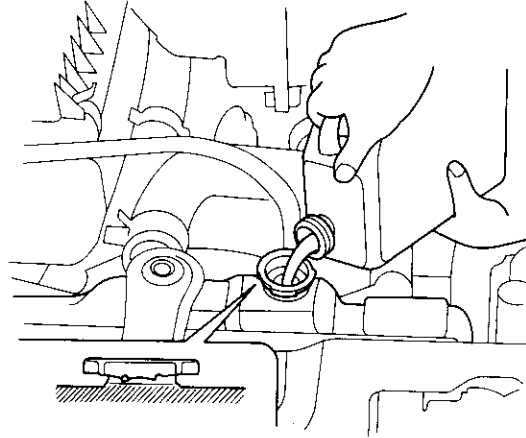

- Start the engine and let it run until it warms up (the radiator fan comes on at least twice).
- Turn off the engine. Check the level in the radiator, add coolant if needed.
- Put the radiator cap on tightly, then run the engine again and check for leaks.



Cap Testing

1. Remove the radiator cap, wet its seal with engine coolant, then install it on the pressure tester.

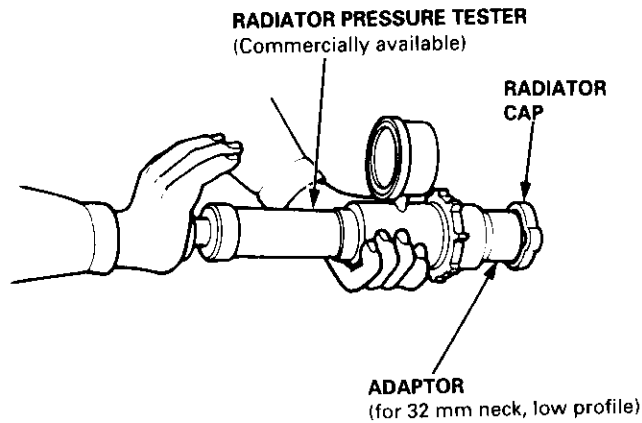

2. Apply a pressure of 93 – 123 kPa (0.95 – 1.25 kgf/cm², 14 – 18 psi).
3. Check for a drop in pressure.
4. If the pressure drops, replace the cap.

Testing

1. Wait until the engine is cool, then carefully remove the radiator cap and fill the radiator with engine coolant to the top of the filler neck.
2. Attach the pressure tester to the radiator and apply a pressure of 93 – 123 kPa (0.95 – 1.25 kgf/cm², 14 – 18 psi).

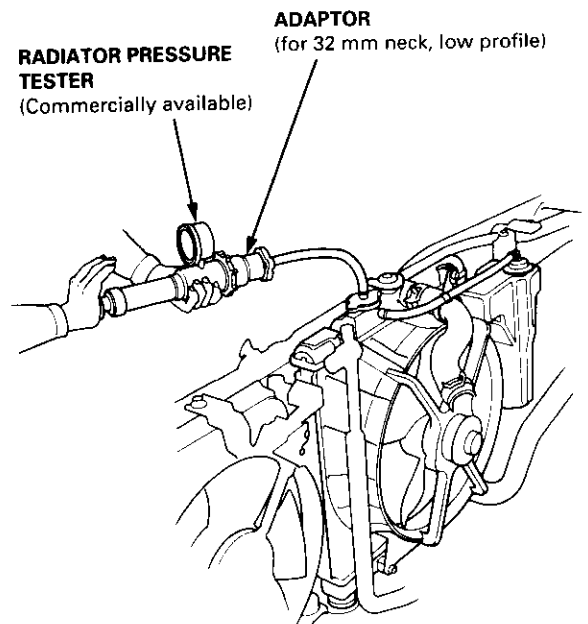

3. Inspect for engine coolant leaks and a drop in pressure.
4. Remove the tester and reinstall the radiator cap.

NOTE: Check for engine oil in the coolant and/or coolant in the engine oil.

Thermostat

Replacement

NOTE: Use a new O-ring when reassembling.

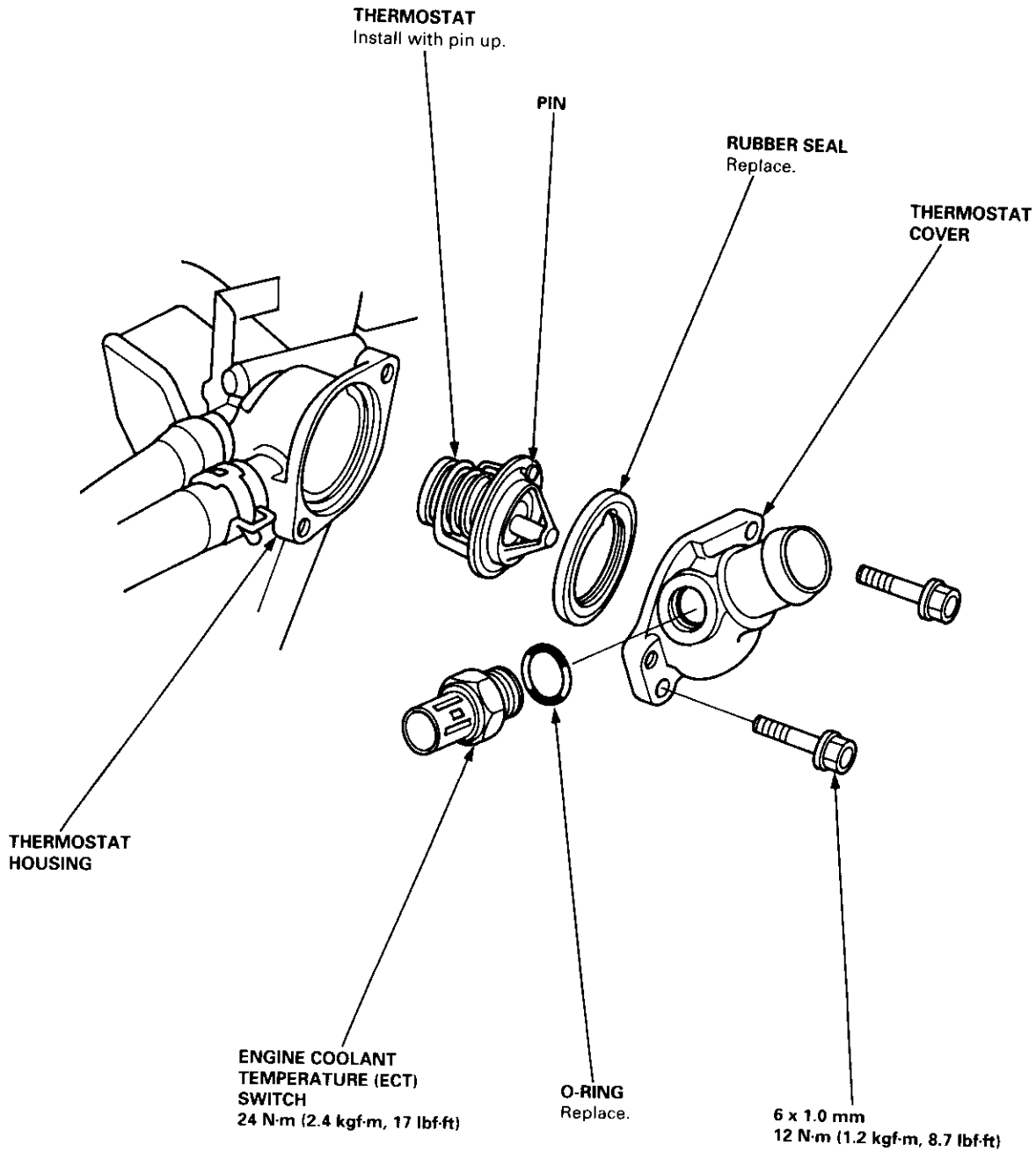



Testing

Replace the thermostat if it is open at room temperature.

To test a closed thermostat:

1. Suspend the thermostat in a container of water as shown.

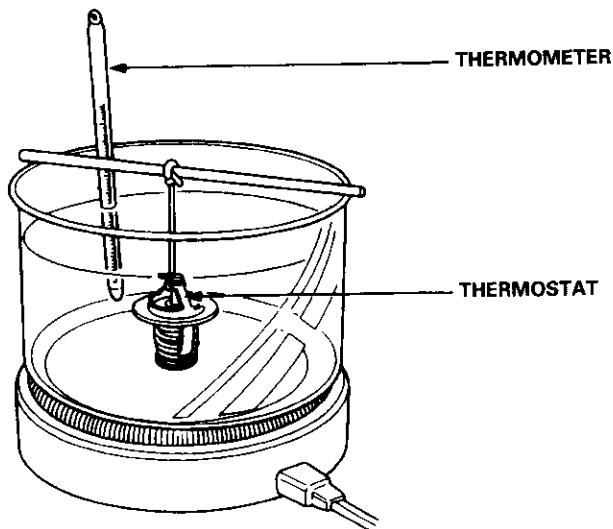

2. Heat the water, and check the temperature with a thermometer. Check the temperature at which the thermostat first opens, and at which it is fully open.

CAUTION: Do not let the thermometer touch the bottom of the hot container.

3. Measure lift height of the thermostat when fully open.

STANDARD THERMOSTAT

Lift height: above 8.0 mm (0.31 in)
 Starts opening: 169° - 176°F (76° - 80°C)
 Fully open: 194°F (90°C)

Testing

⚠ WARNING Removing the ECT switch while the engine is hot can cause the coolant to spray out, seriously scalding you. Always let the engine and radiator cool down before removing the ECT switch.

NOTE: Bleed air from the cooling system after installing the ECT switch (see page 10-7).

1. Remove the ECT switch from the thermostat housing (see page 10-10).
2. Suspend the ECT switch in a container of water as shown.

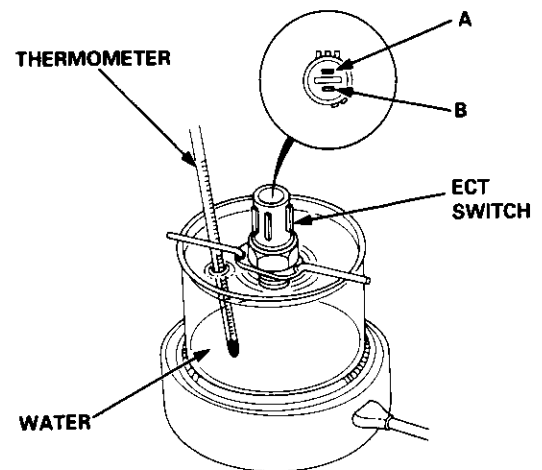

3. Heat the water, and check the temperature with a thermometer.

CAUTION: Do not let the thermometer touch the bottom of the hot container.

4. Measure the resistance between the A and B terminals according to the table.

Operation		Temperature	Terminal	
			A	B
SWITCH	ON	196° - 203°F (91° - 95°C)	○	○
	OFF	5° - 15°F (3° - 8°C) lower than the temperature when it goes on		



B16A2 engine:

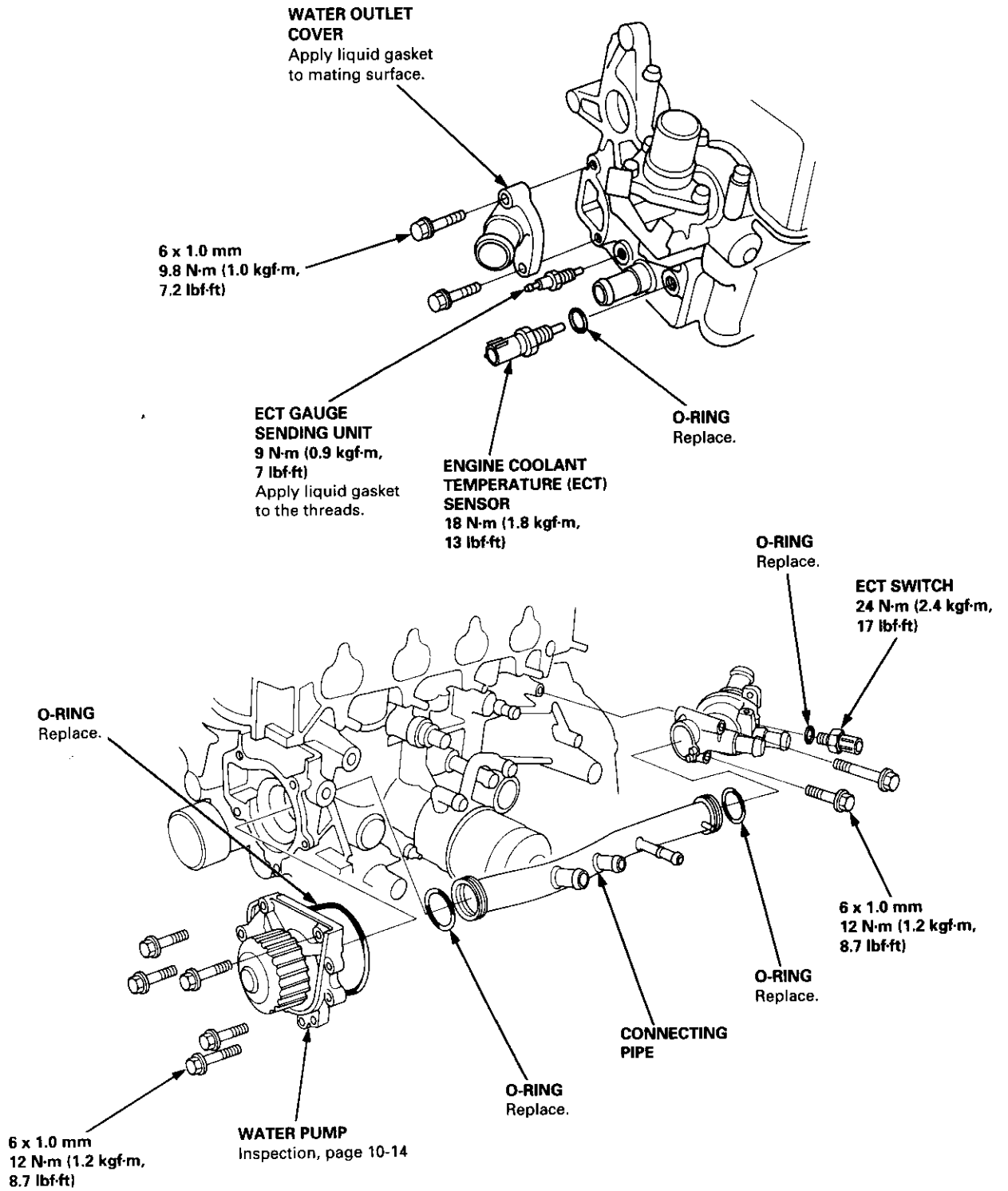

Water Pump

Inspection

1. Remove the timing belt (see section 6).
2. Turn the water pump pulley counterclockwise. Check that it turns freely.
3. Check for signs of seal leakage.

NOTE: A small amount of "weeping" from the bleed hole is normal.

D16Y5, D16Y7, D16Y8 engines:

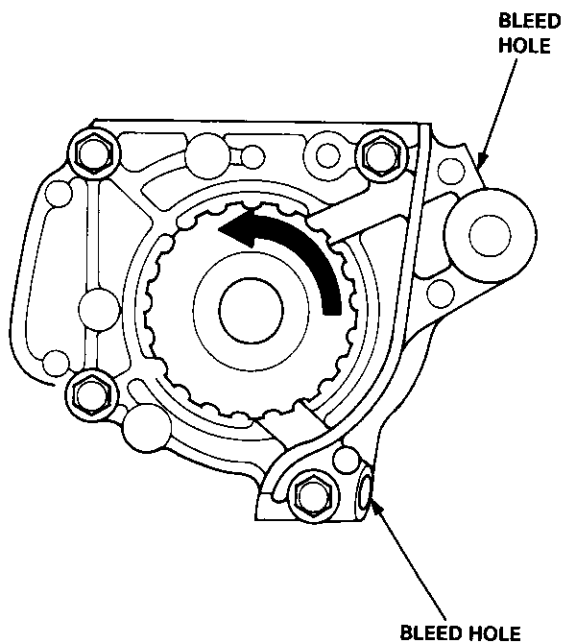

B16A2 engine:

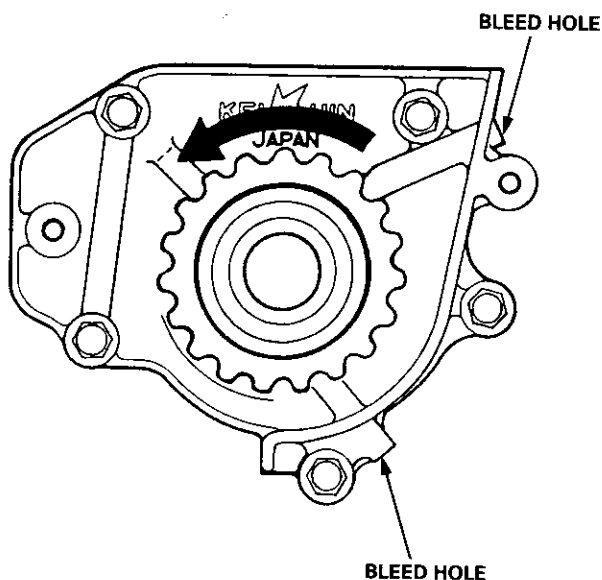

Replacement

1. Remove the timing belt (see section 6).
2. Remove the water pump by removing five bolts.

NOTE: Inspect, repair and clean the O-ring groove and mating surface with the cylinder block.

D16Y5, D16Y7, D16Y8 engines:

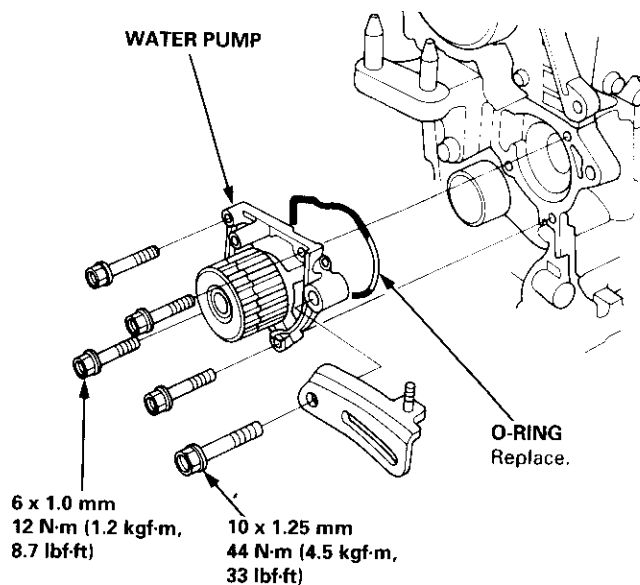

B16A2 engine:

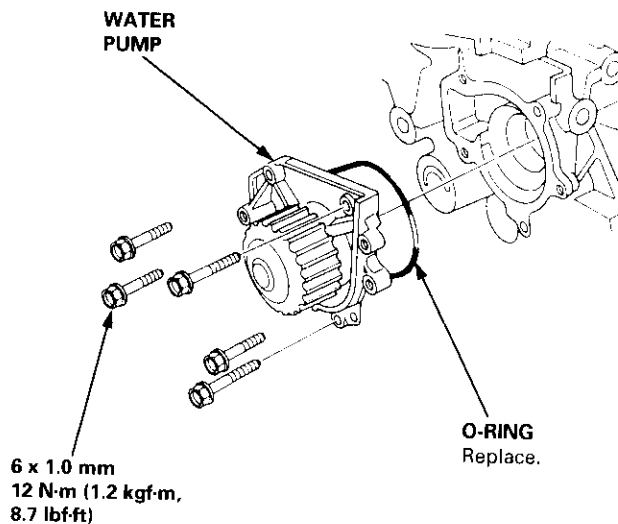

3. Install the water pump in the reverse order of removal.

NOTE:

- Keep the O-ring in position when installing.
- Clean the spilled engine coolant.