

Mitchell TechAdvisor™

Ford Bronco 2021

Diagramas de cableado / DIAGRAMAS DE CABLEADO OEM

SISTEMA DE AUDIO

Fig. 1: Diagramas de cableado del sistema de audio (1 de 14)

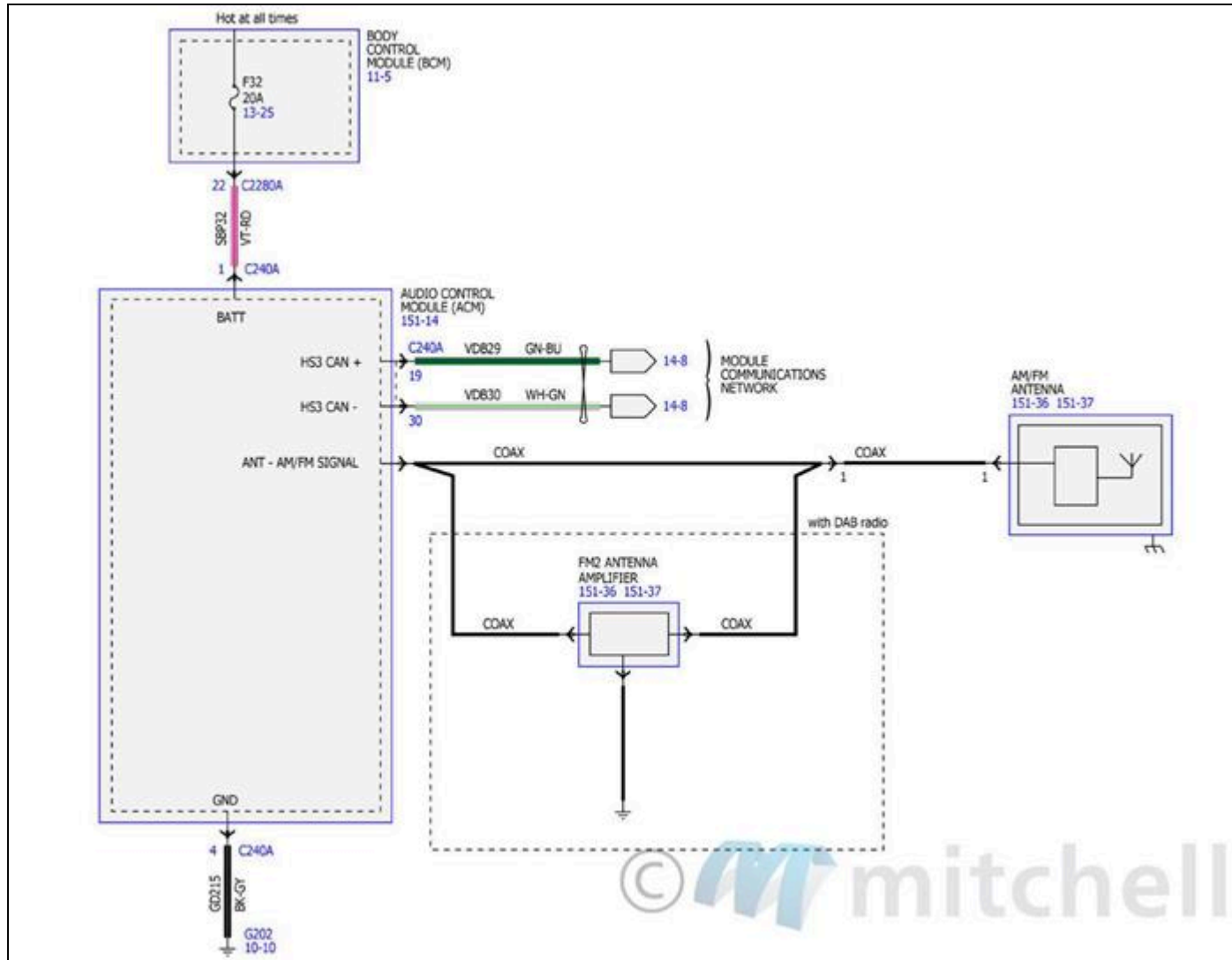

Fig. 2: Diagramas de cableado del sistema de audio (2 de 14)

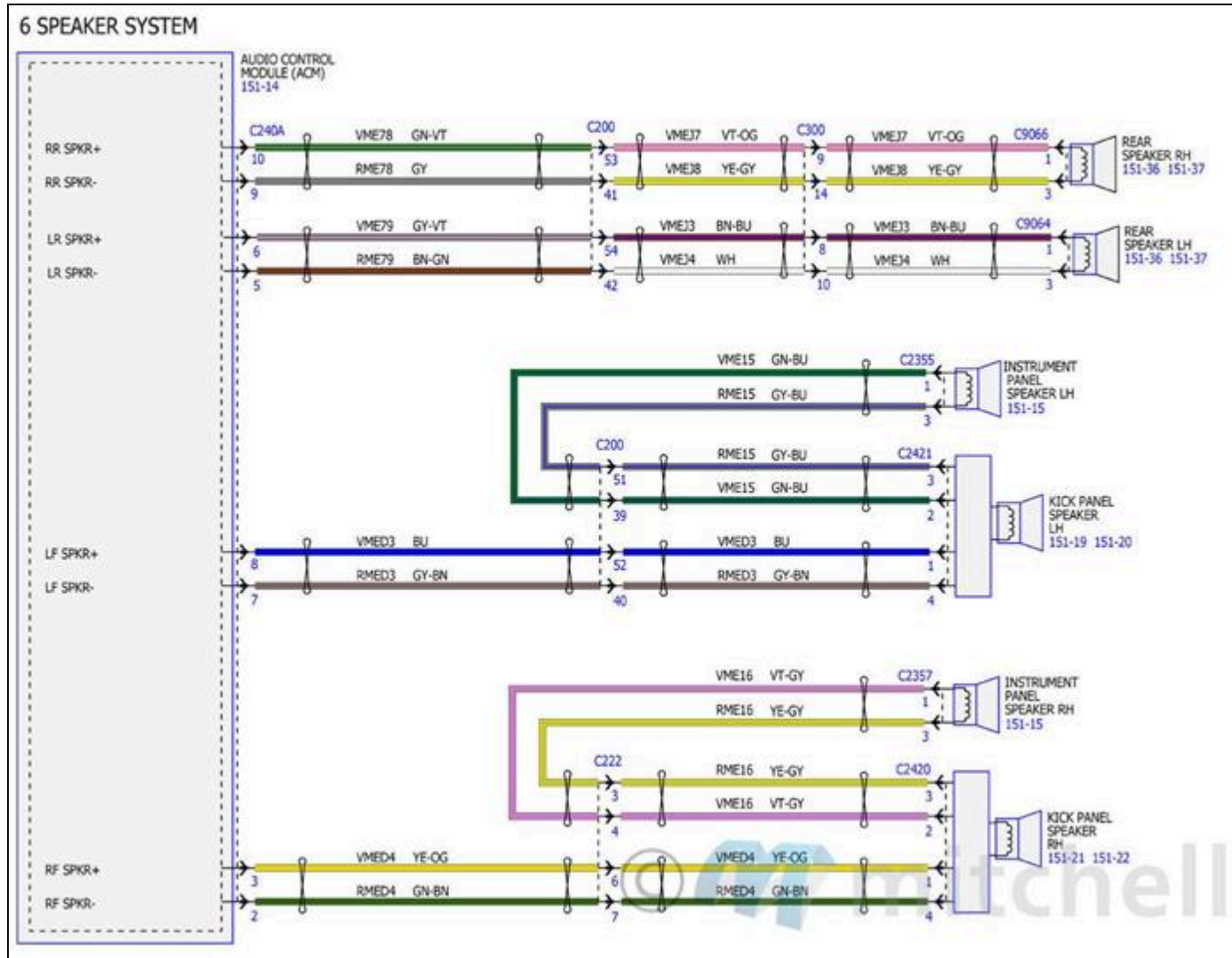

Fig. 3: Diagramas de cableado del sistema de audio (3 de 14)

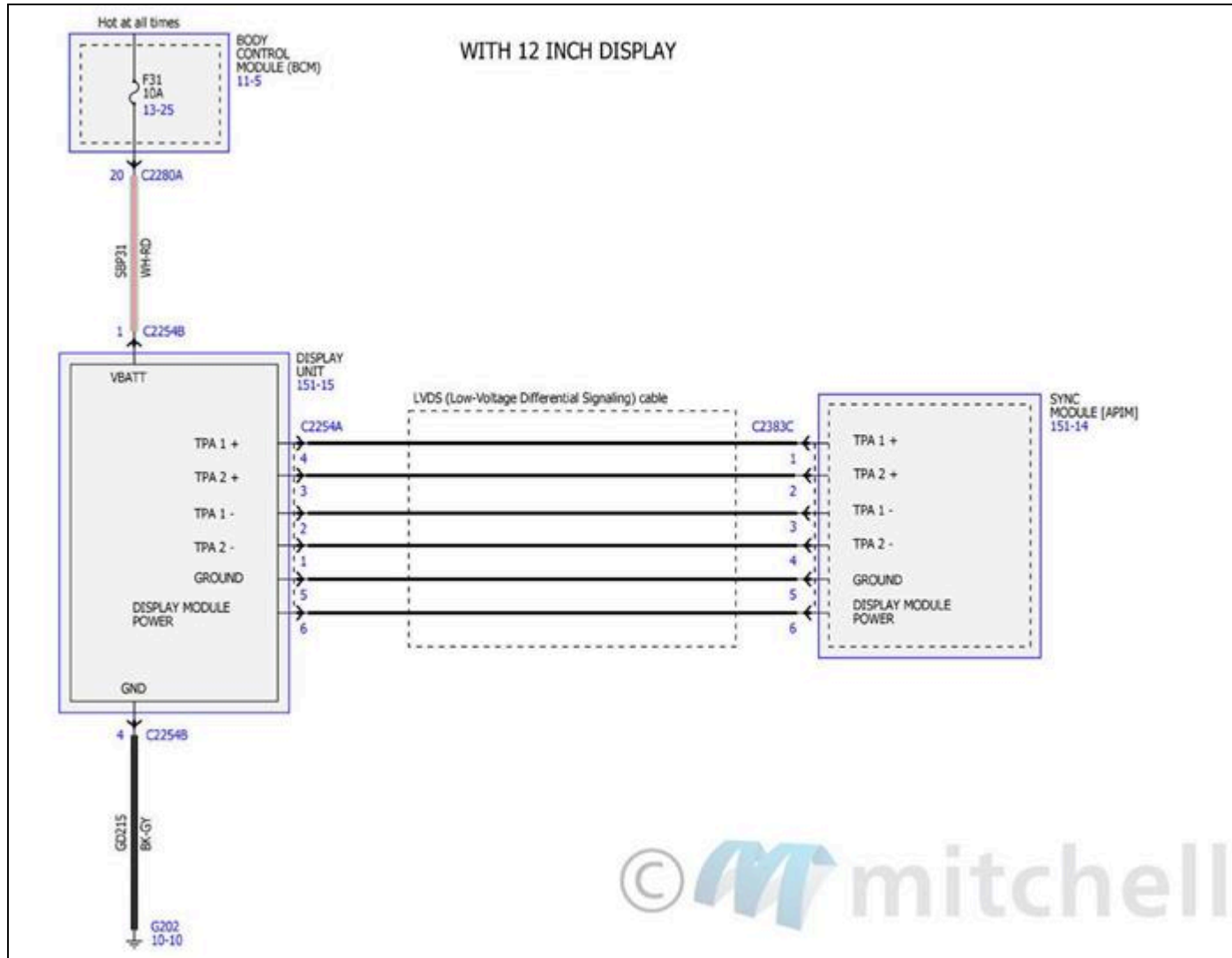

Fig. 4: Diagramas de cableado del sistema de audio (4 de 14)

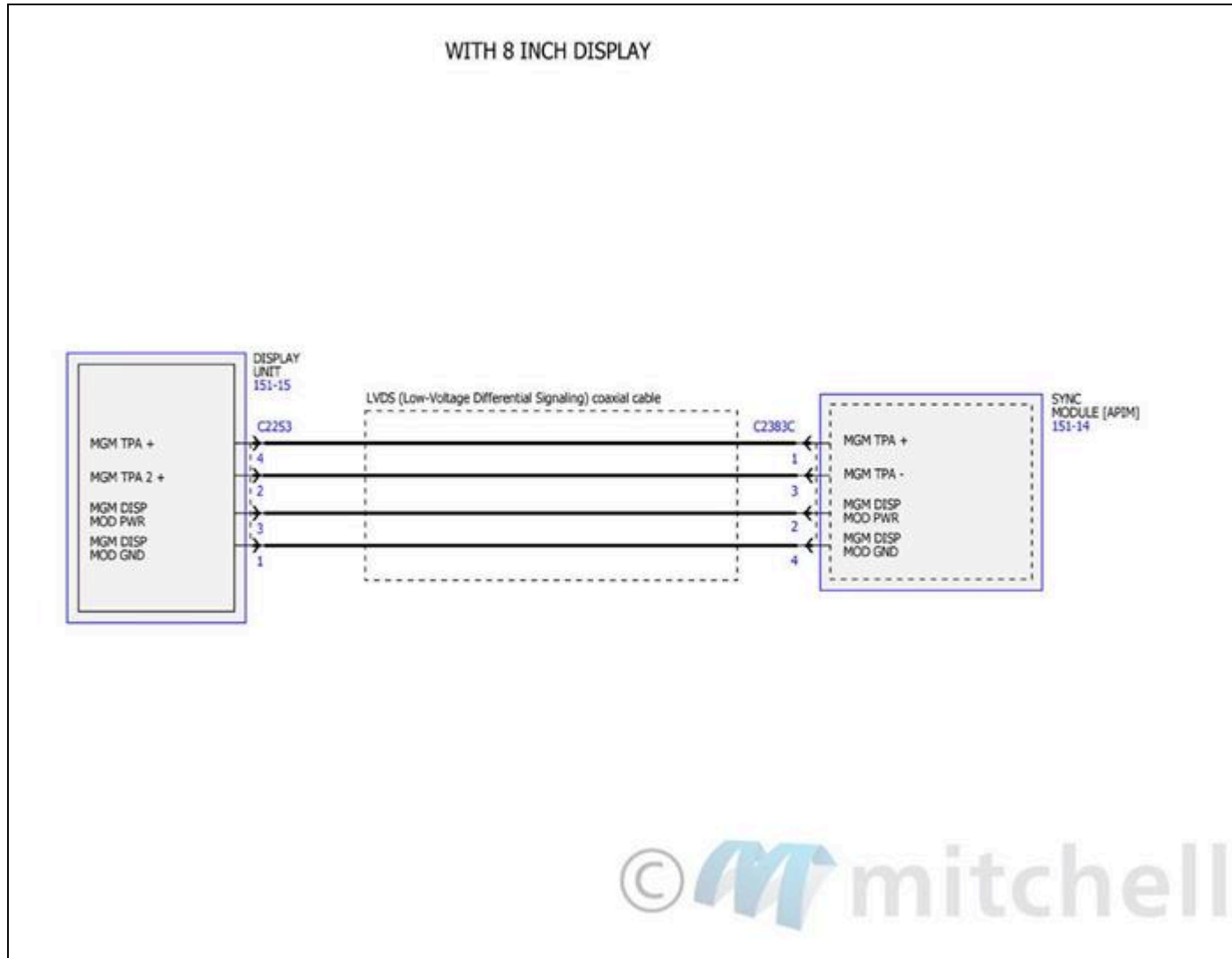

Fig. 5: Diagramas de cableado del sistema de audio (5 de 14)

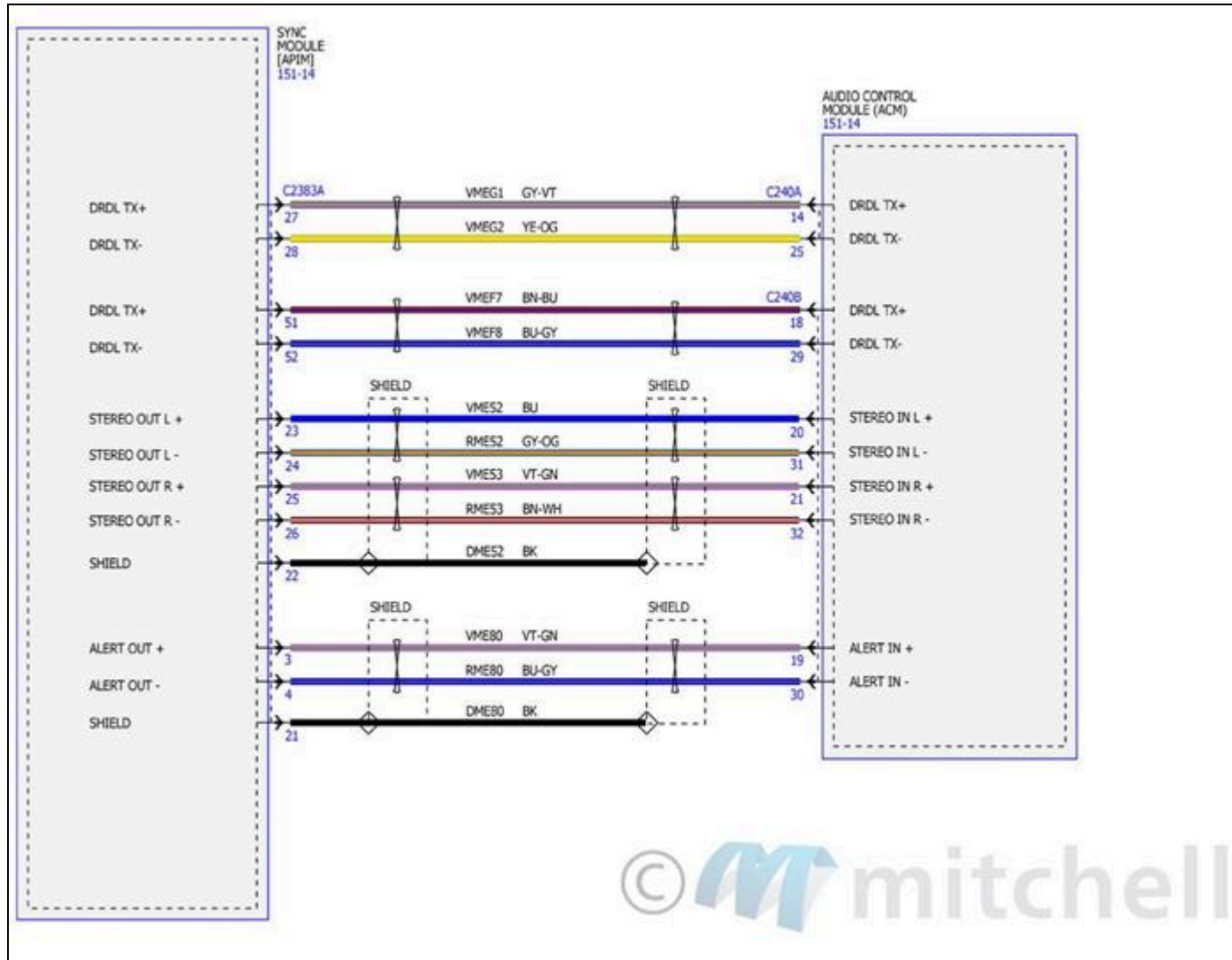

Fig. 6: Diagramas de cableado del sistema de audio (6 de 14)

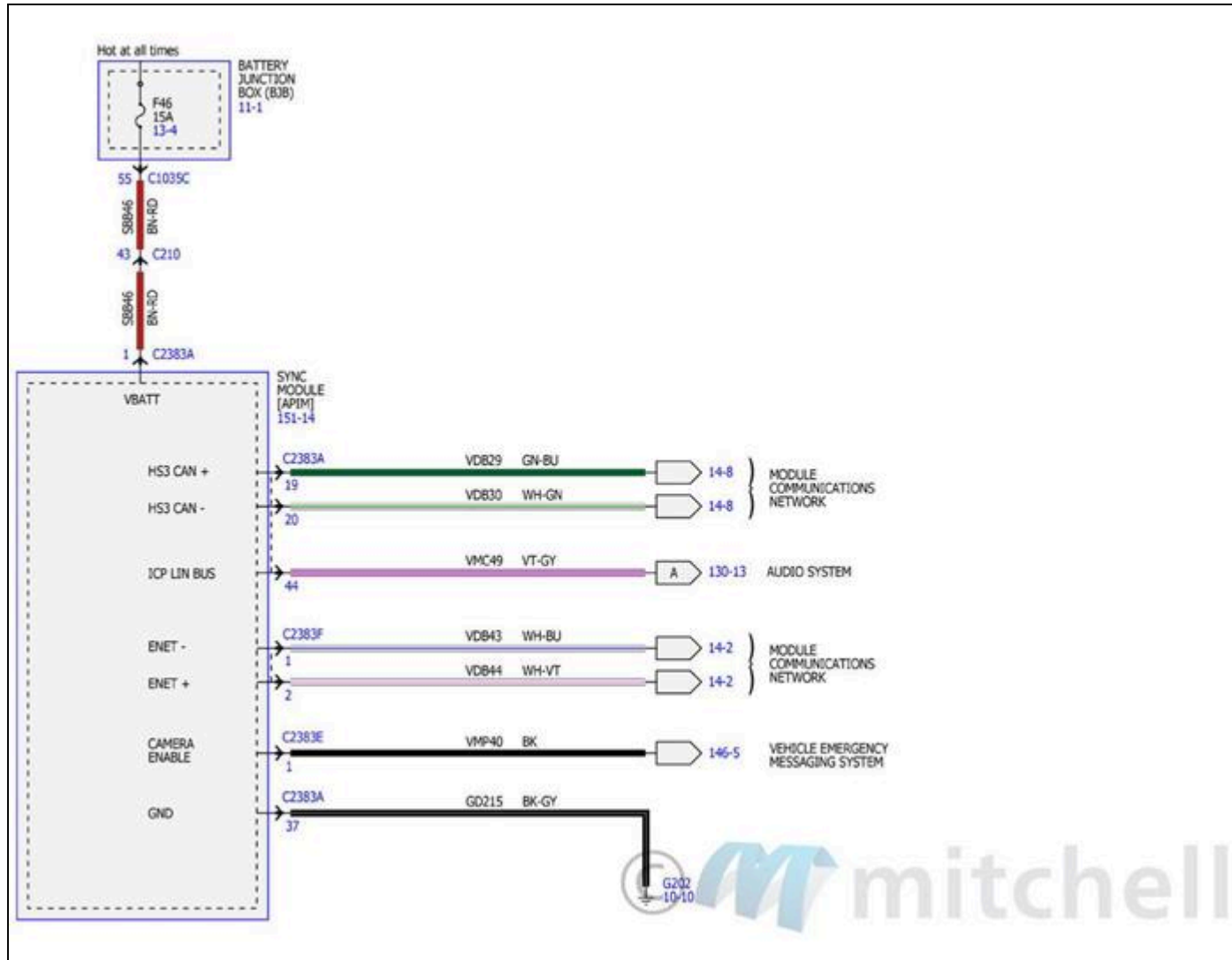

Fig. 7: Diagramas de cableado del sistema de audio (7 de 14)

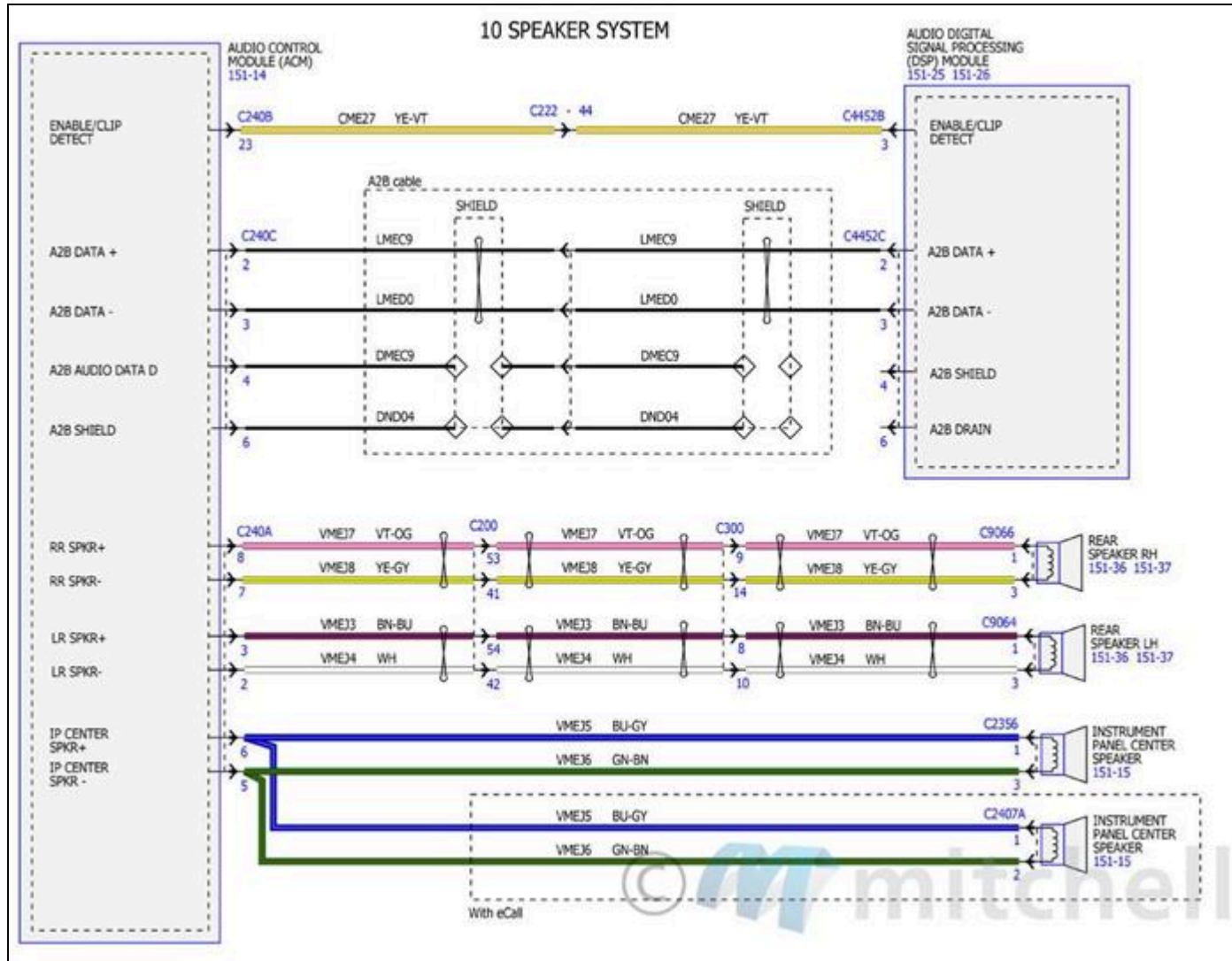

Fig. 8: Diagramas de cableado del sistema de audio (8 de 14)

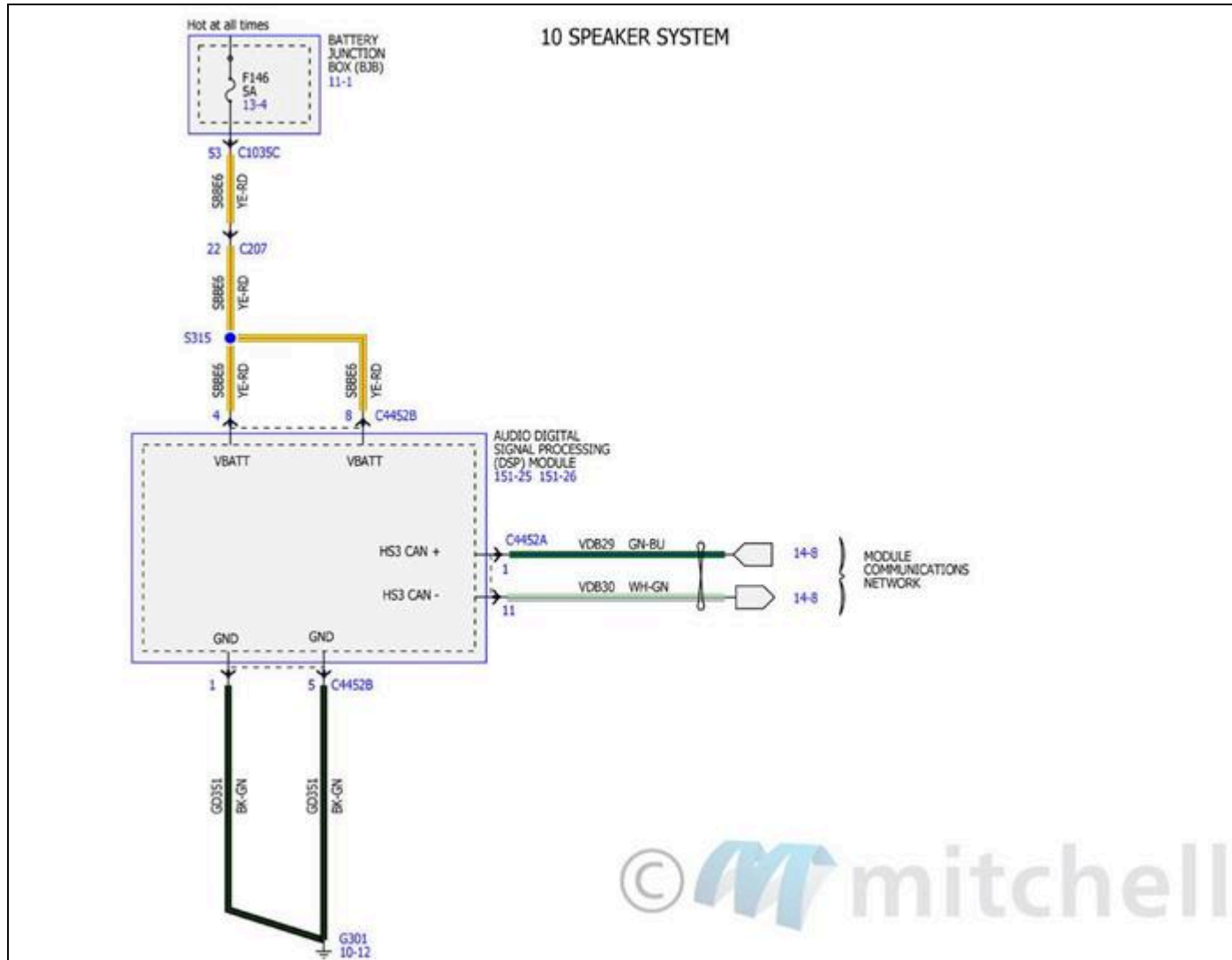

Fig. 9: Diagramas de cableado del sistema de audio (9 de 14)

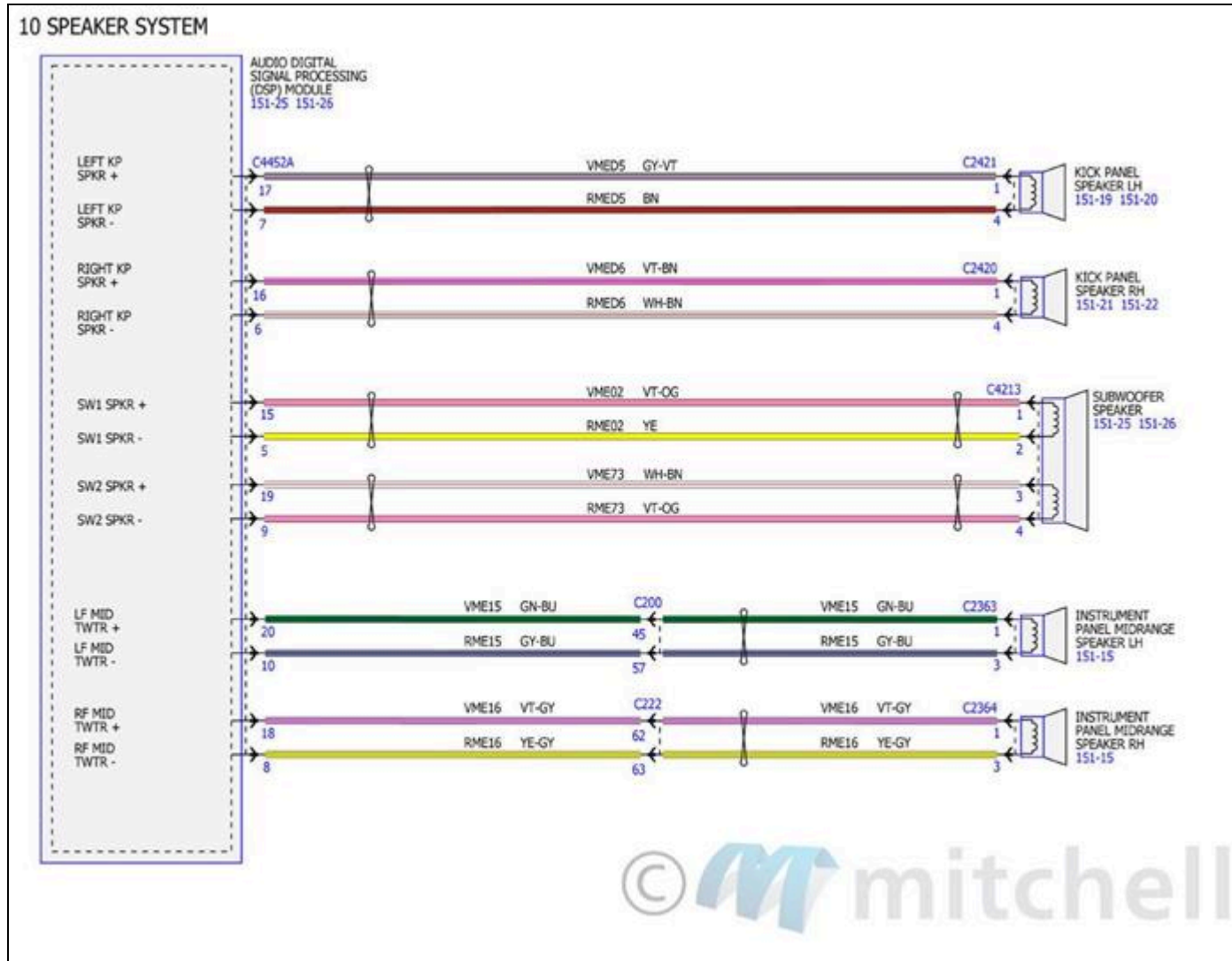

Fig. 10: Diagramas de cableado del sistema de audio (10 de 14)

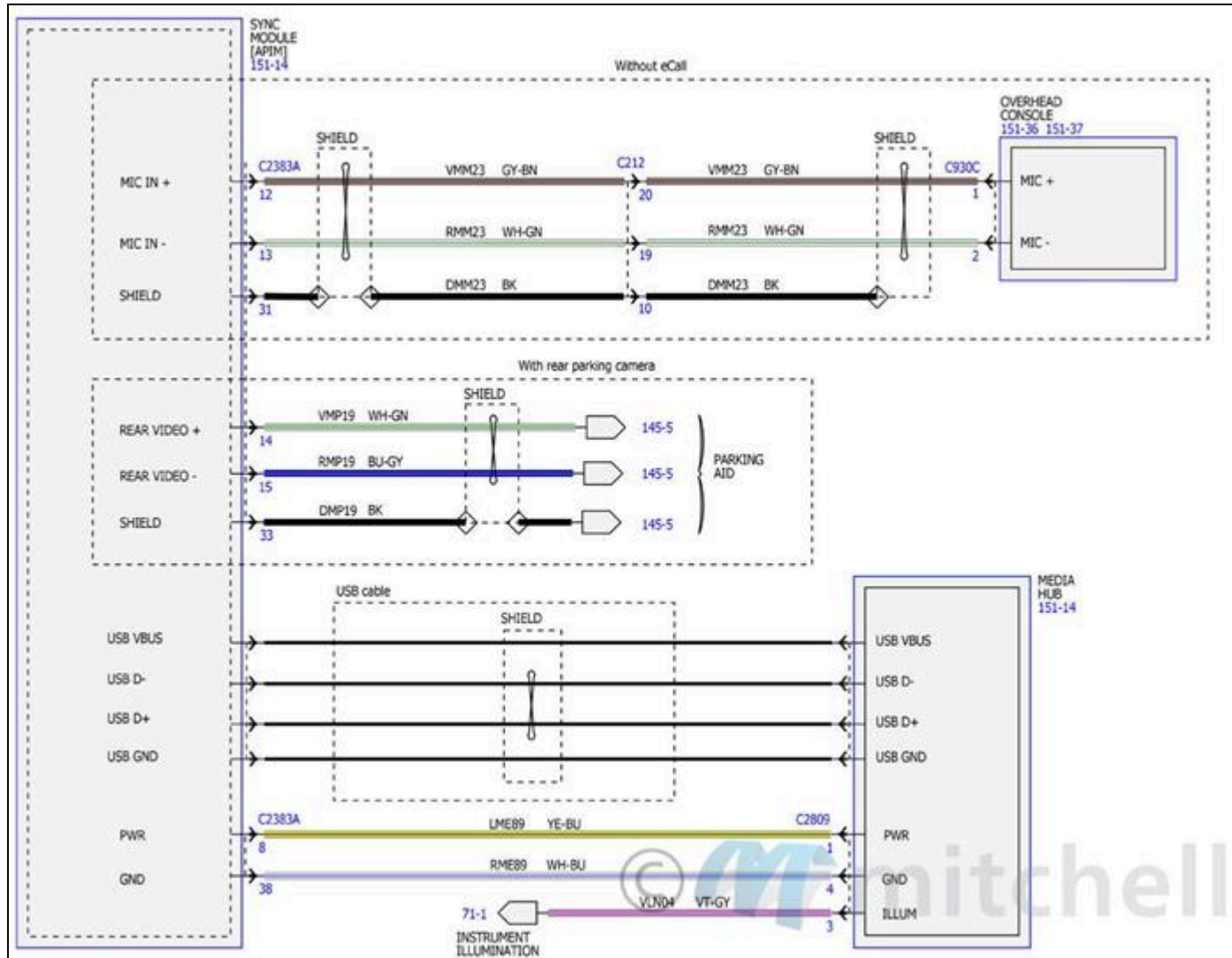

Fig. 11: Diagramas de cableado del sistema de audio (11 de 14)

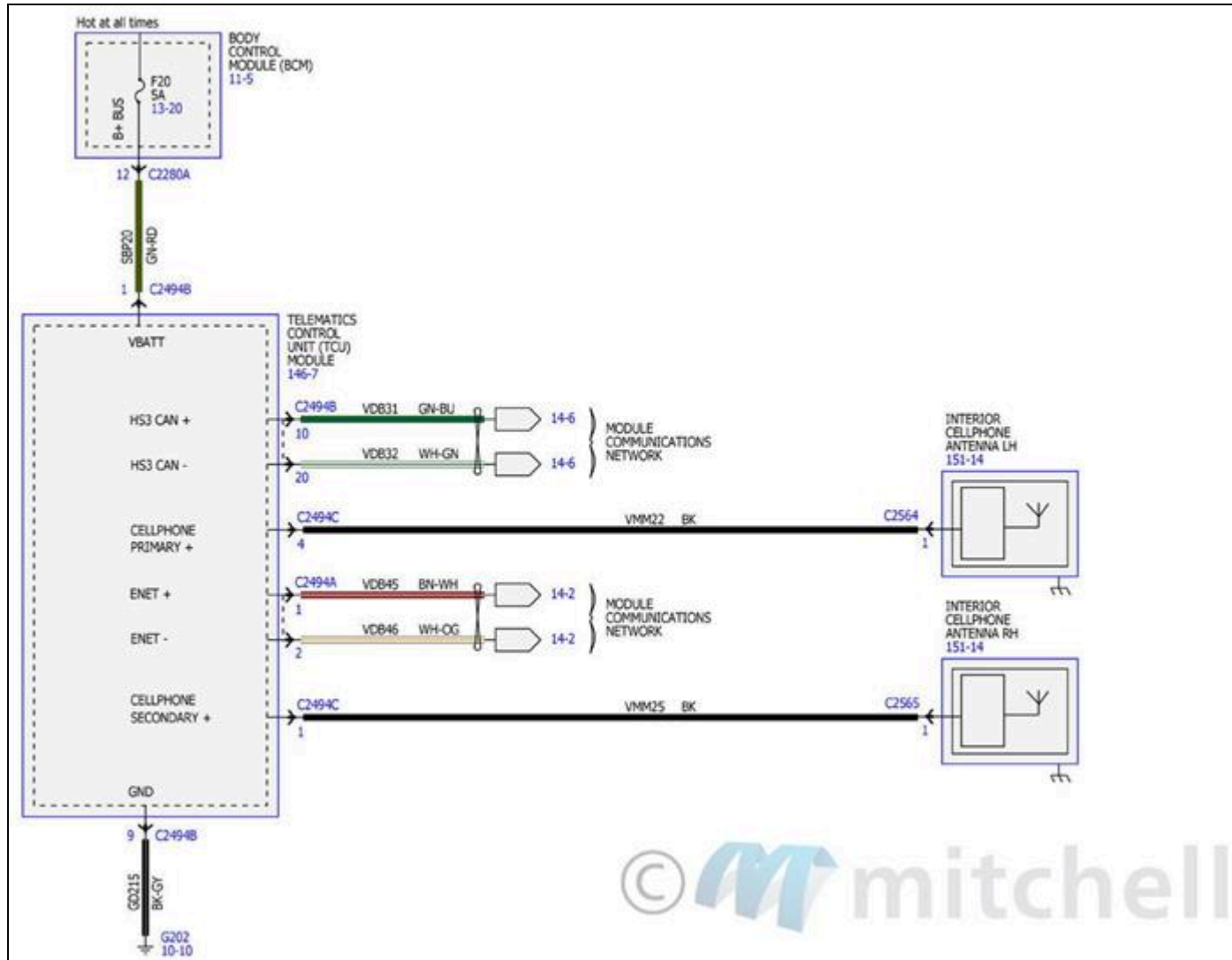

Fig. 12: Diagramas de cableado del sistema de audio (12 de 14)

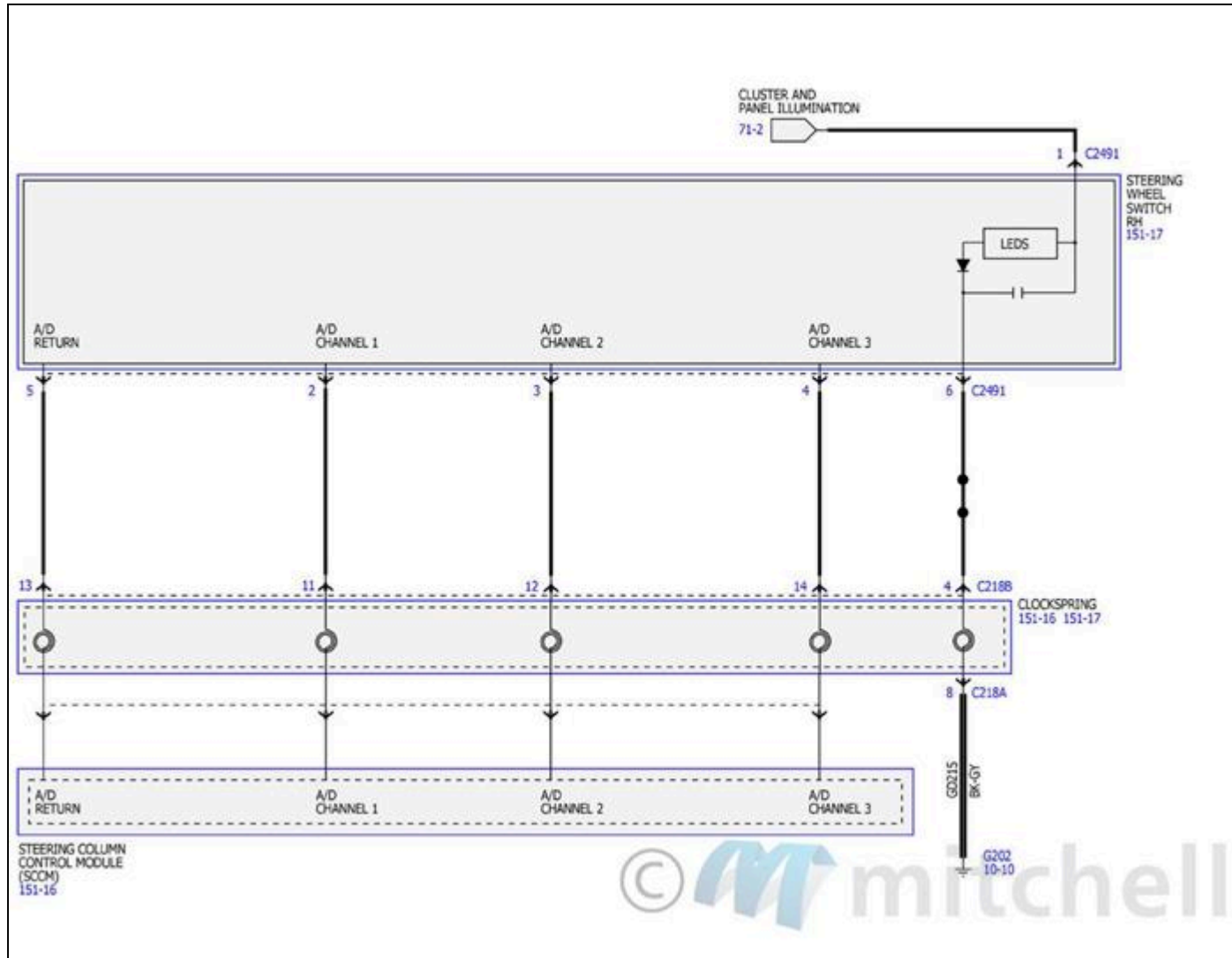

Fig. 13: Diagramas de cableado del sistema de audio (13 de 14)

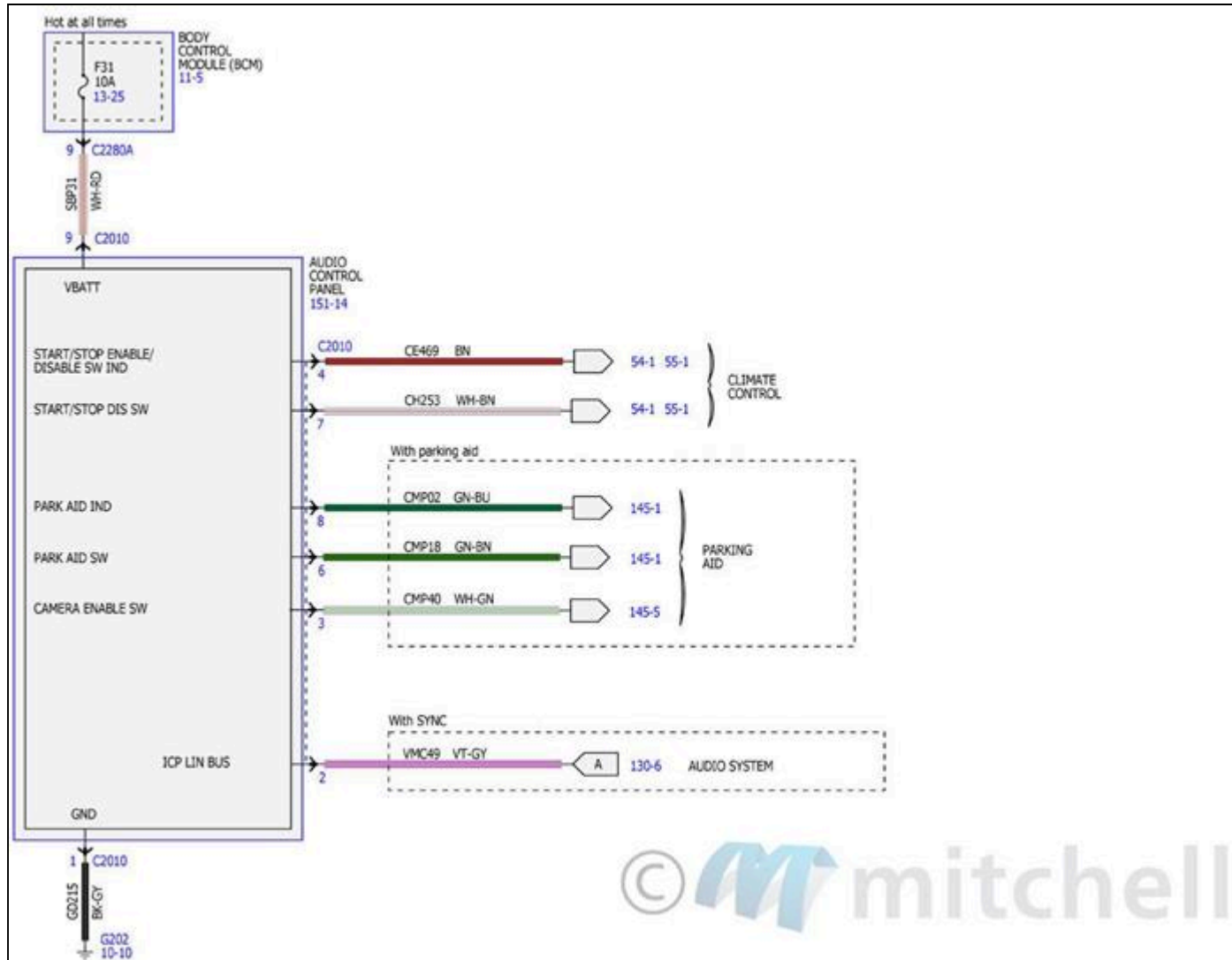
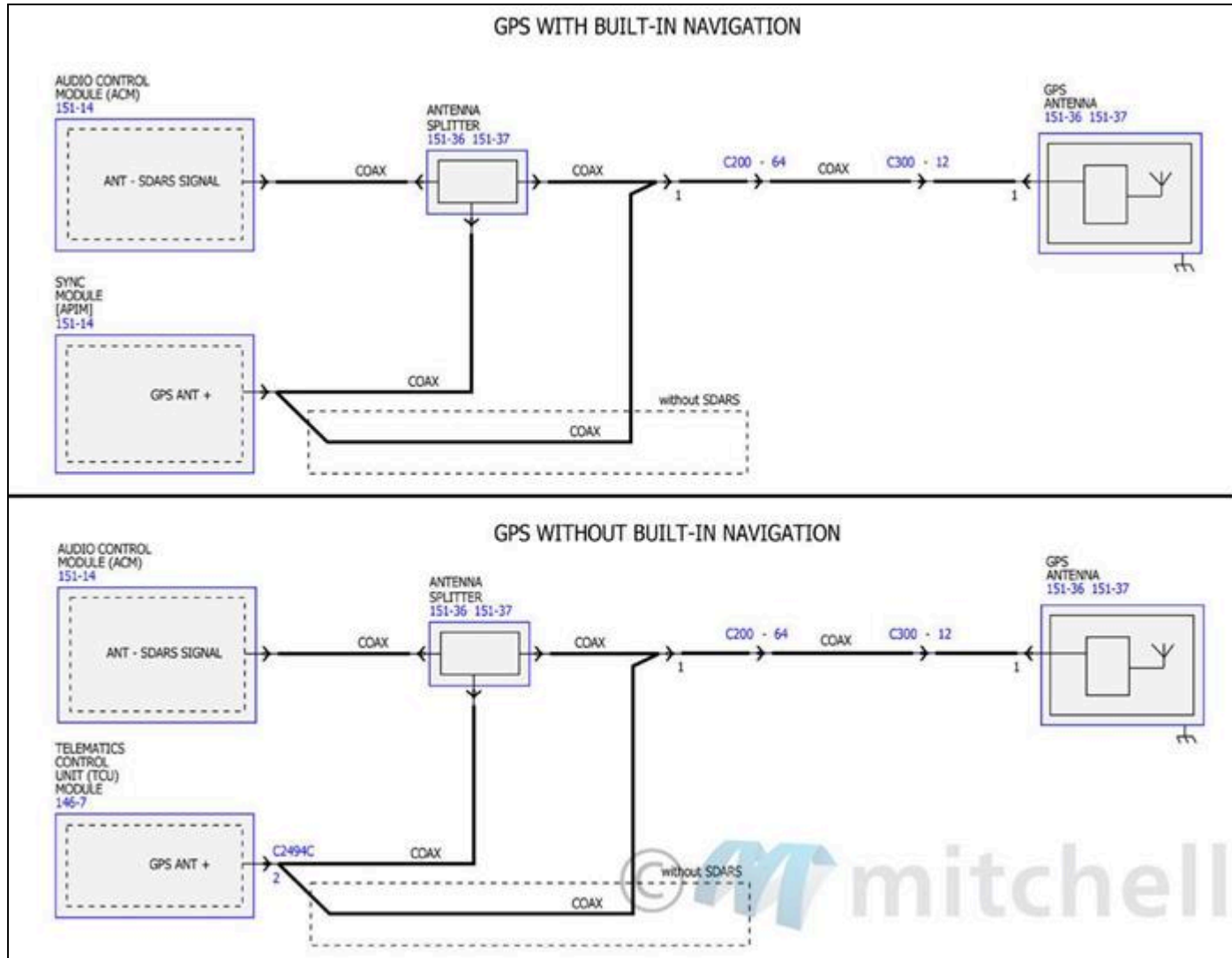

Fig. 14: Diagramas de cableado del sistema de audio (14 de 14)



SISTEMA DE CONTROL DE CLIMA AUTOMÁTICO

Fig. 15: Diagramas de cableado del sistema de control de clima automático (1 de 7)

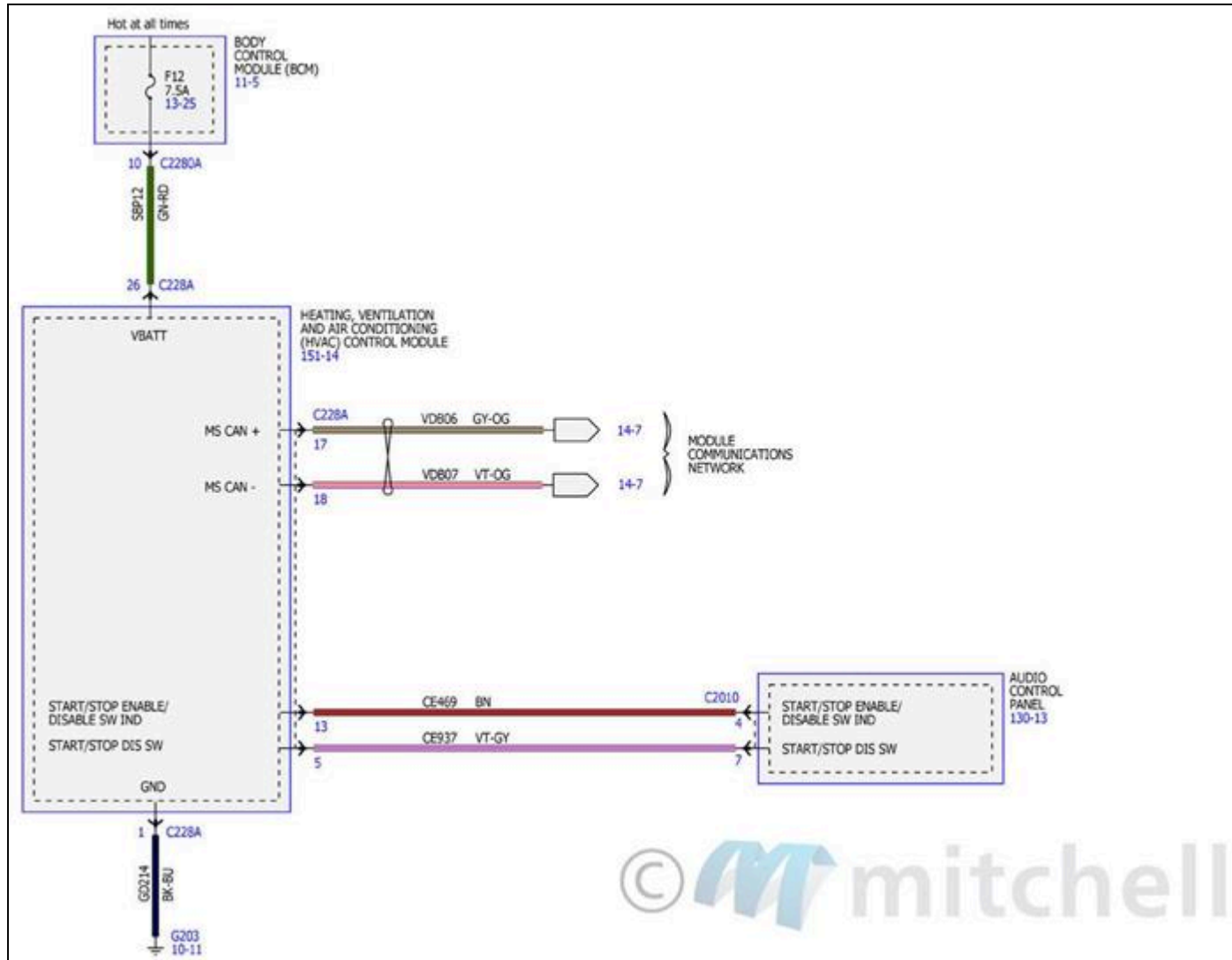

Fig. 16: Diagramas de cableado del sistema de control de clima automático (2 de 7)

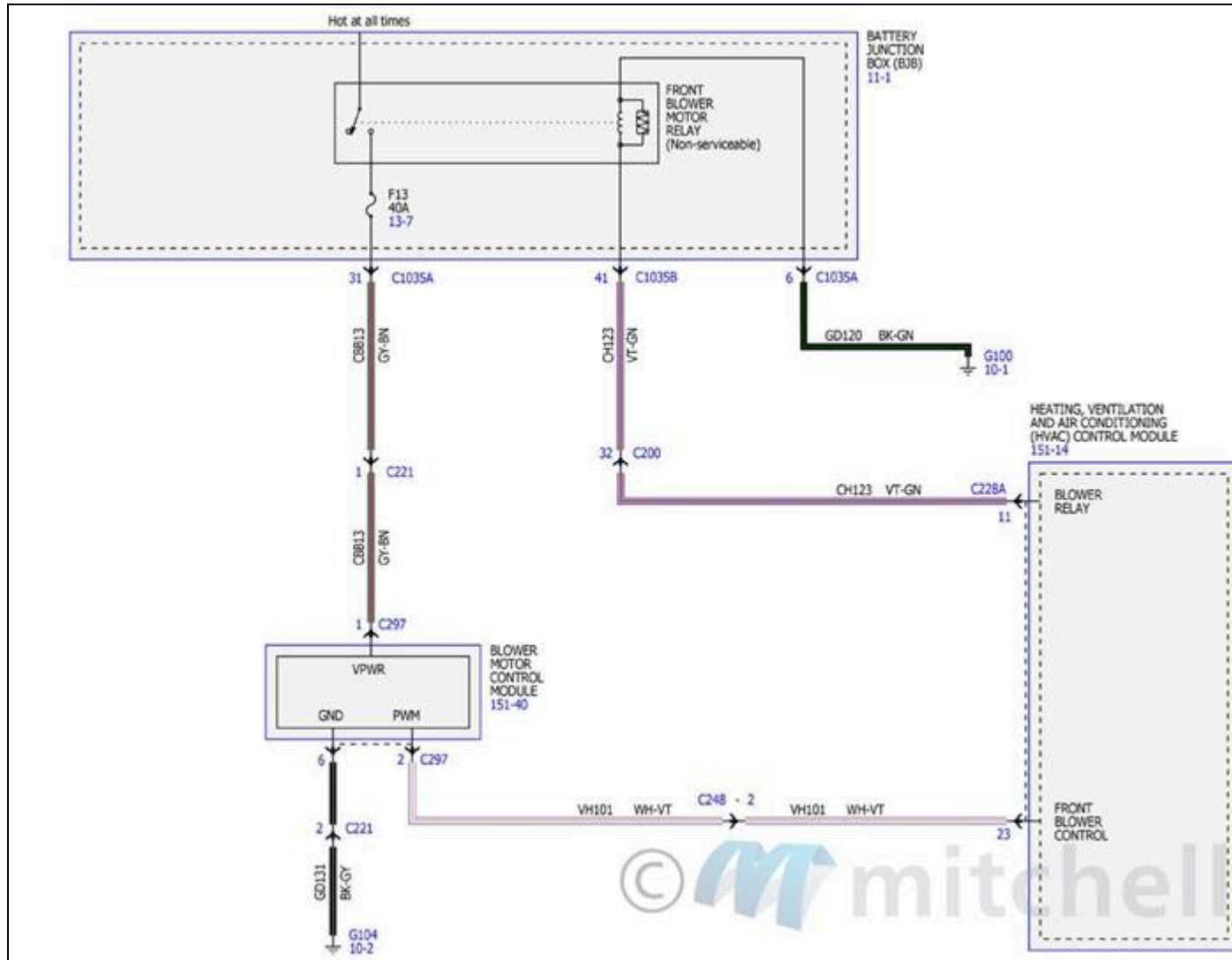

Fig. 17: Diagramas de cableado del sistema de control de clima automático (3 de 7)

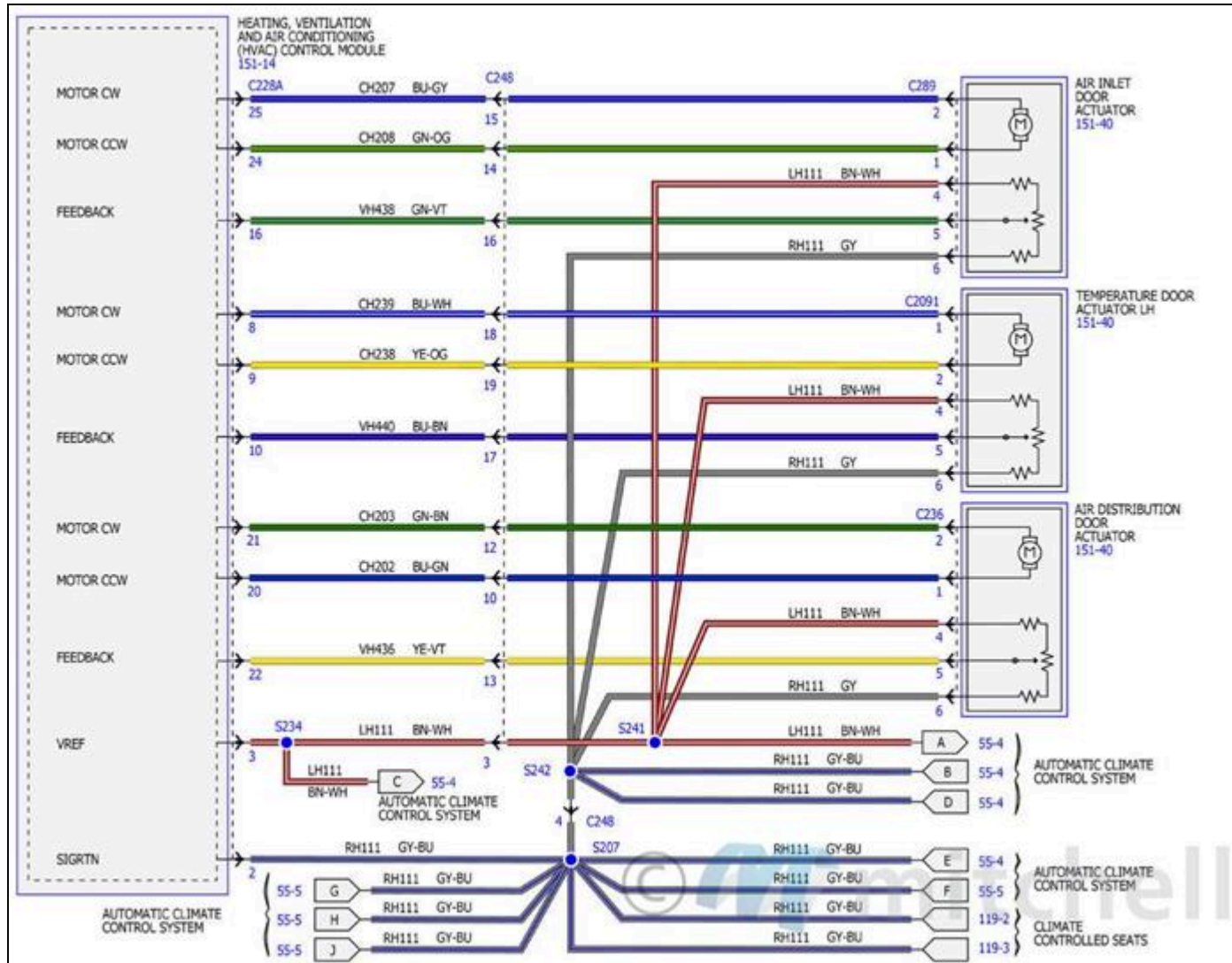

Fig. 18: Diagramas de cableado del sistema de control de clima automático (4 de 7)

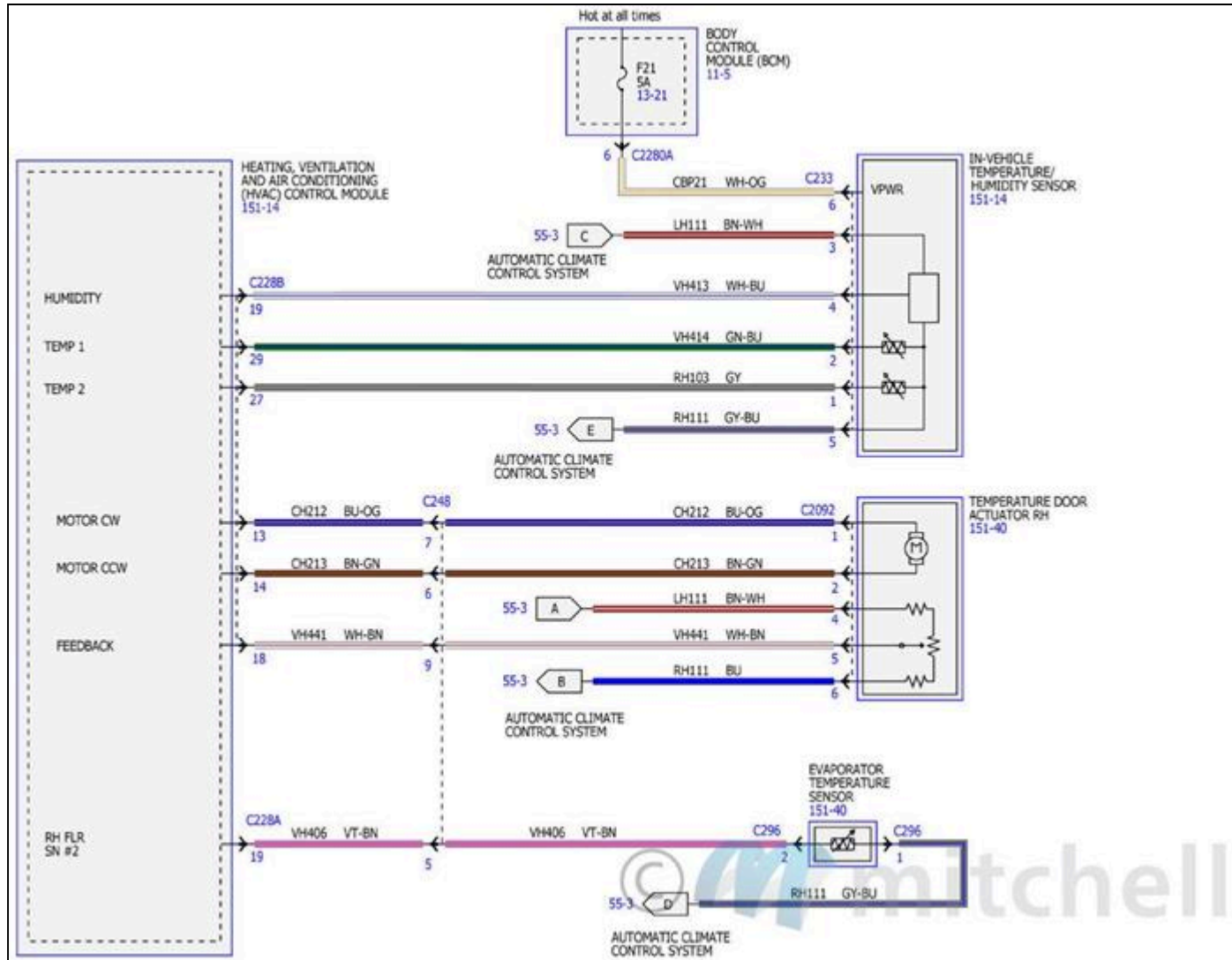

Fig. 19: Diagramas de cableado del sistema de control de clima automático (5 de 7)

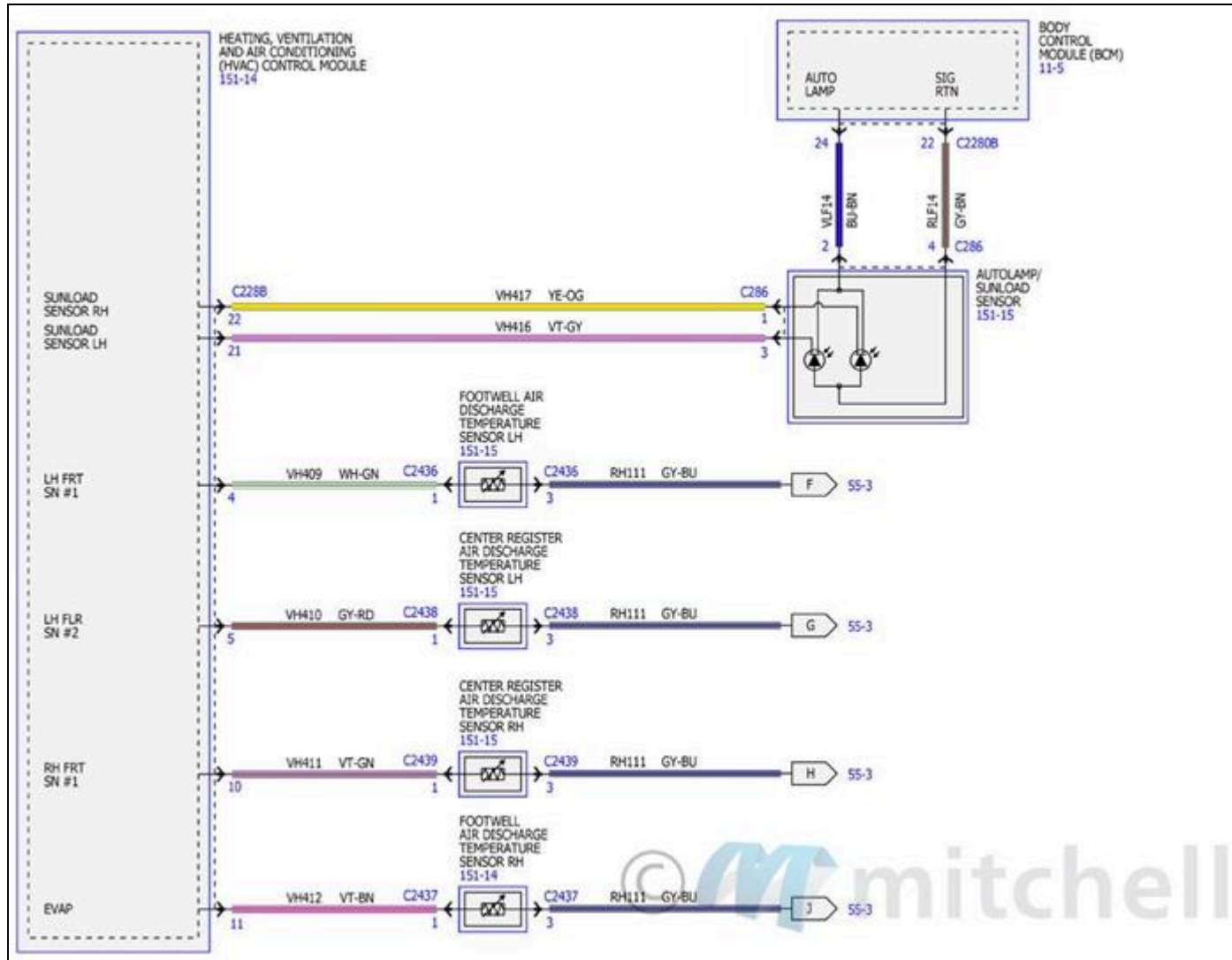

Fig. 20: Diagramas de cableado del sistema de control de clima automático (6 de 7)

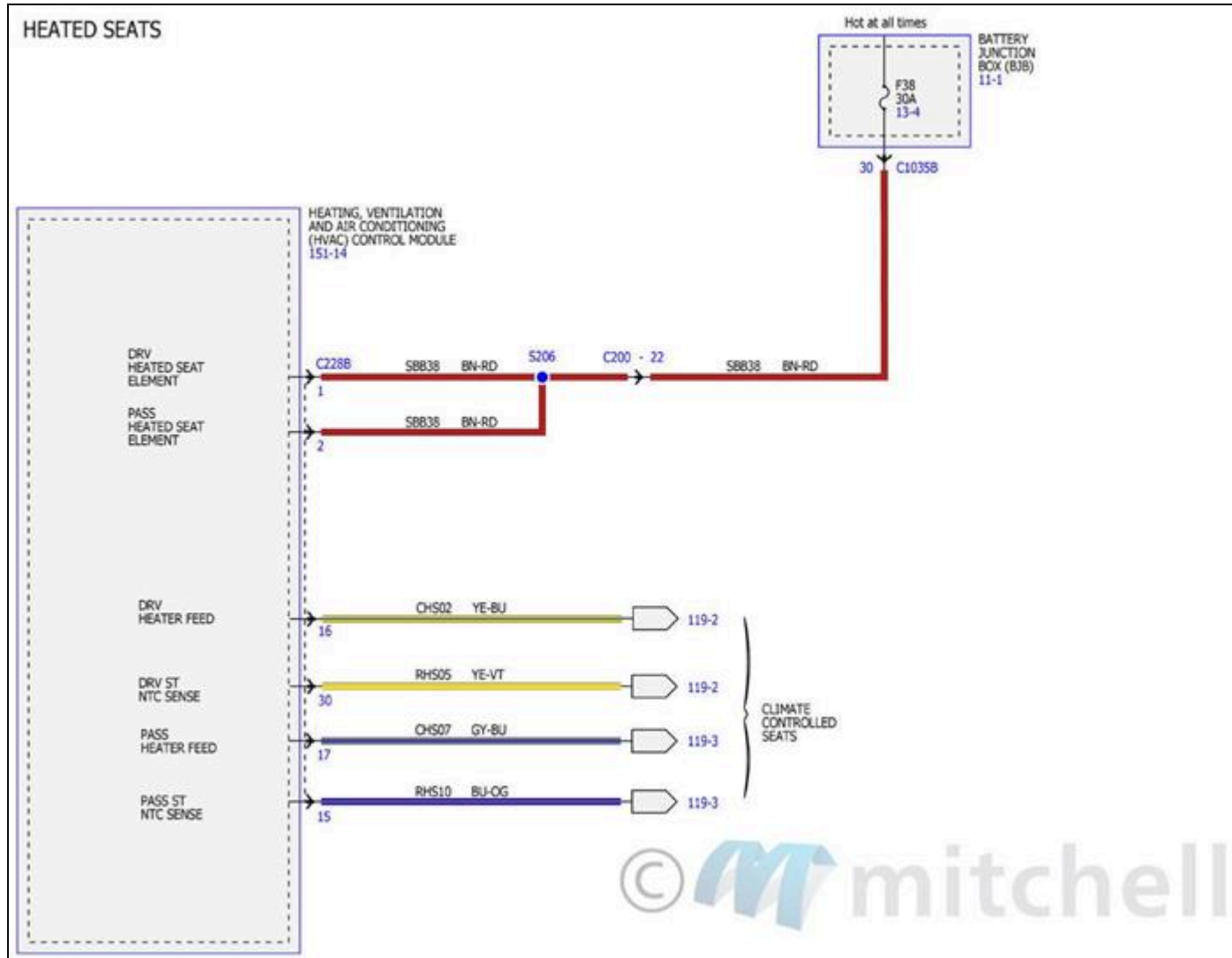
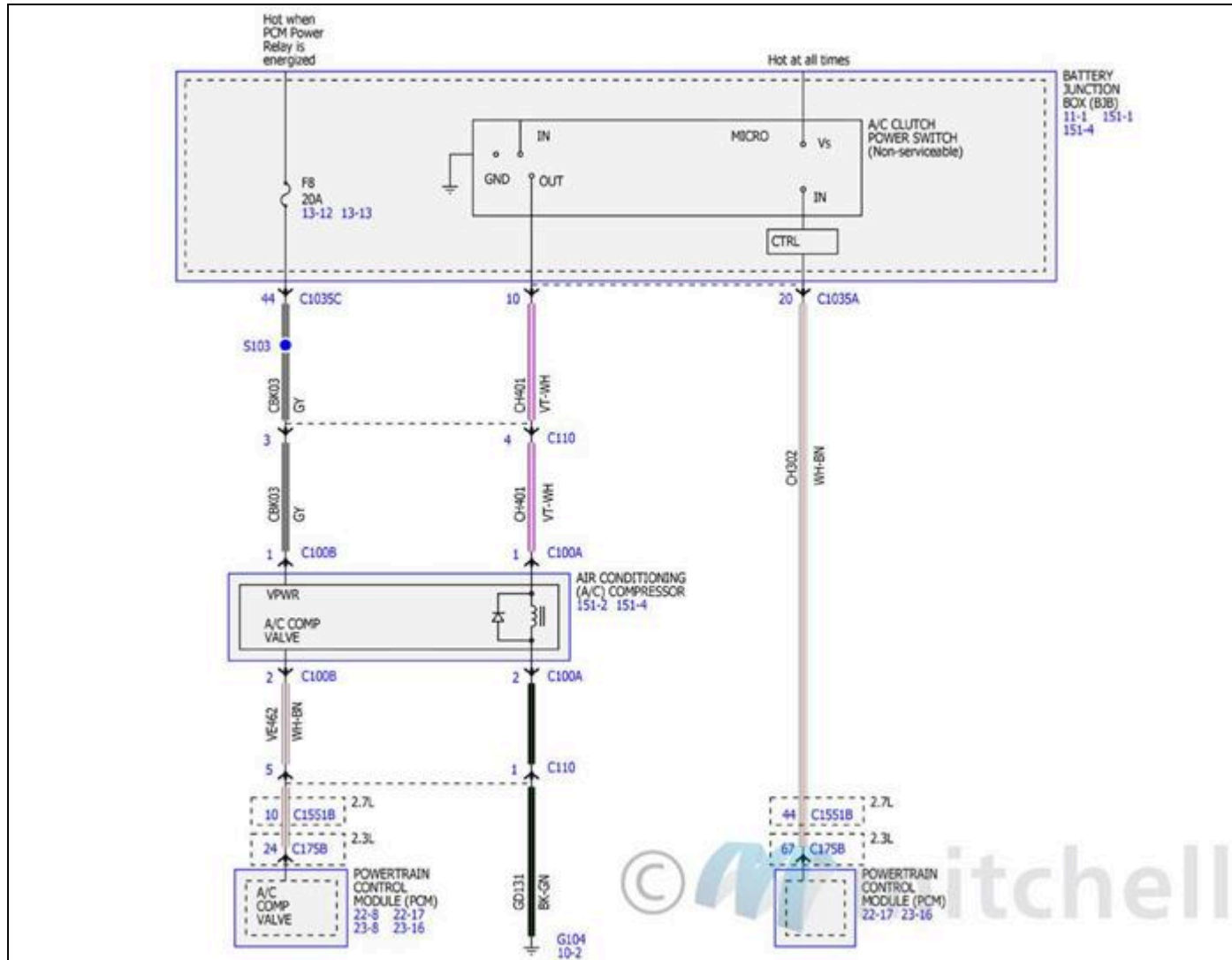
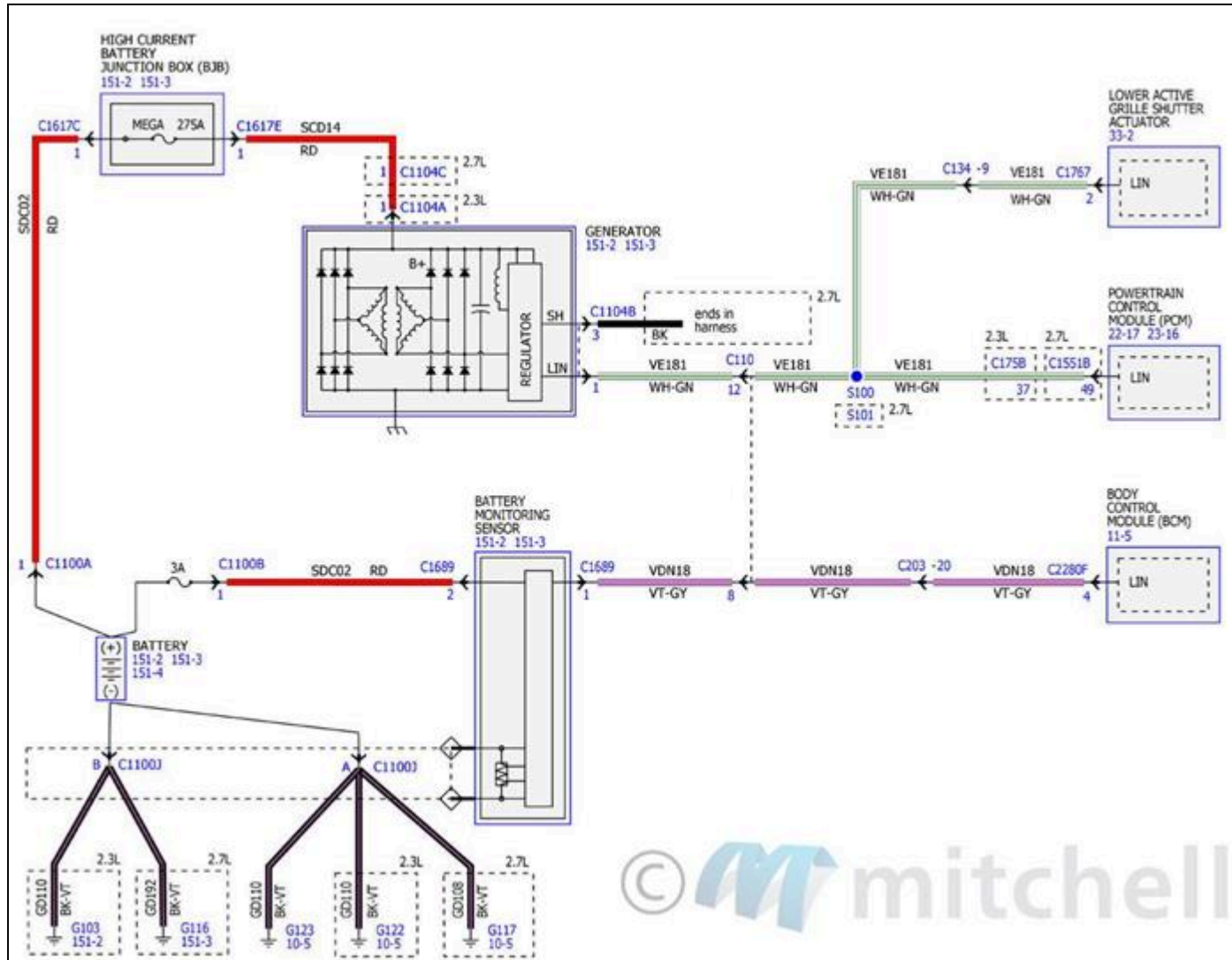

Fig. 21: Diagramas de cableado del sistema de control de clima automático (7 de 7)



SISTEMA DE CARGA

Fig. 22: Diagrama de cableado del sistema de carga



ASIENTOS CON CLIMA CONTROLADO

Fig. 23: Diagramas de cableado de asientos con control de clima (1 de 4)

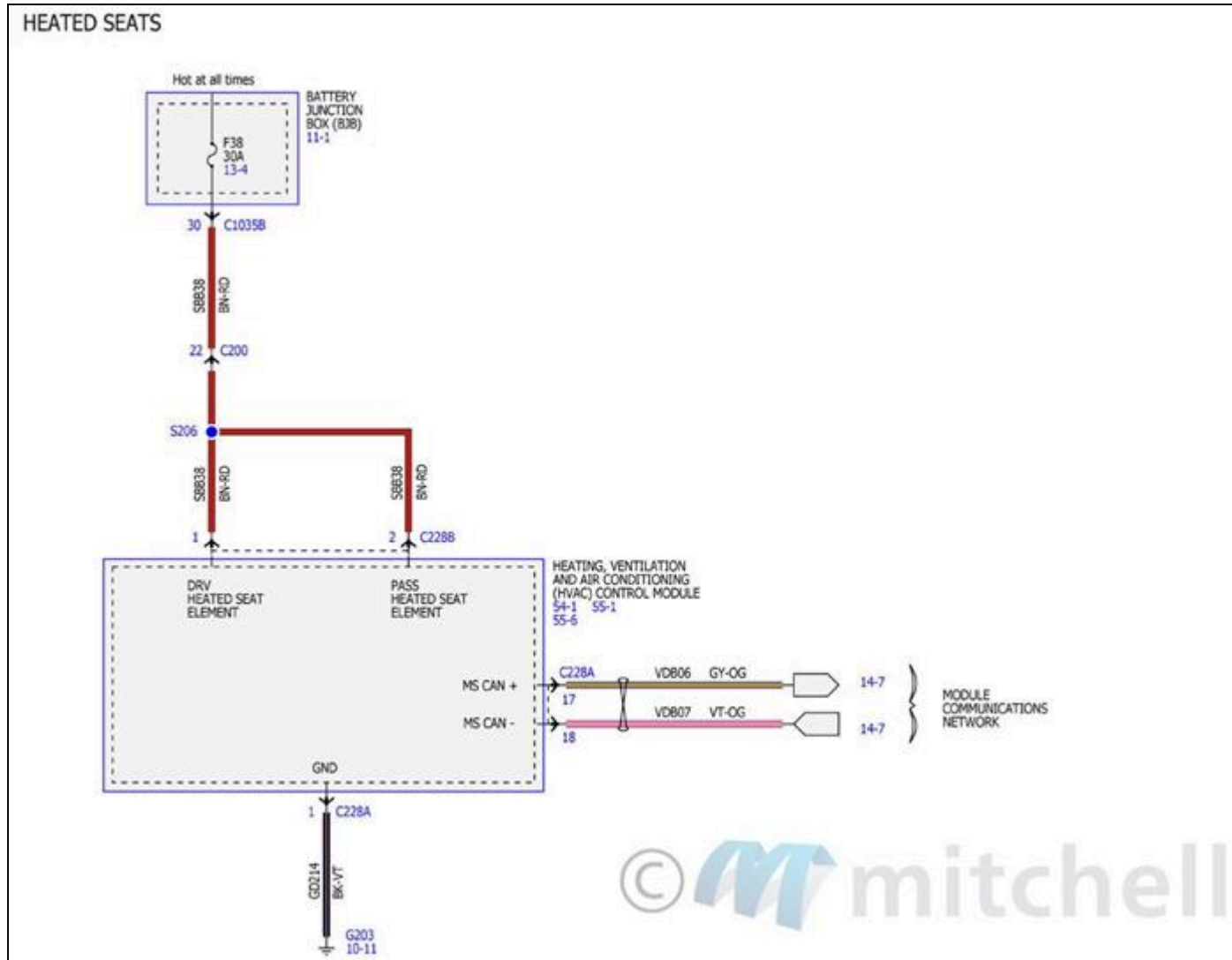

Fig. 24: Diagramas de cableado de asientos con control de clima (2 de 4)

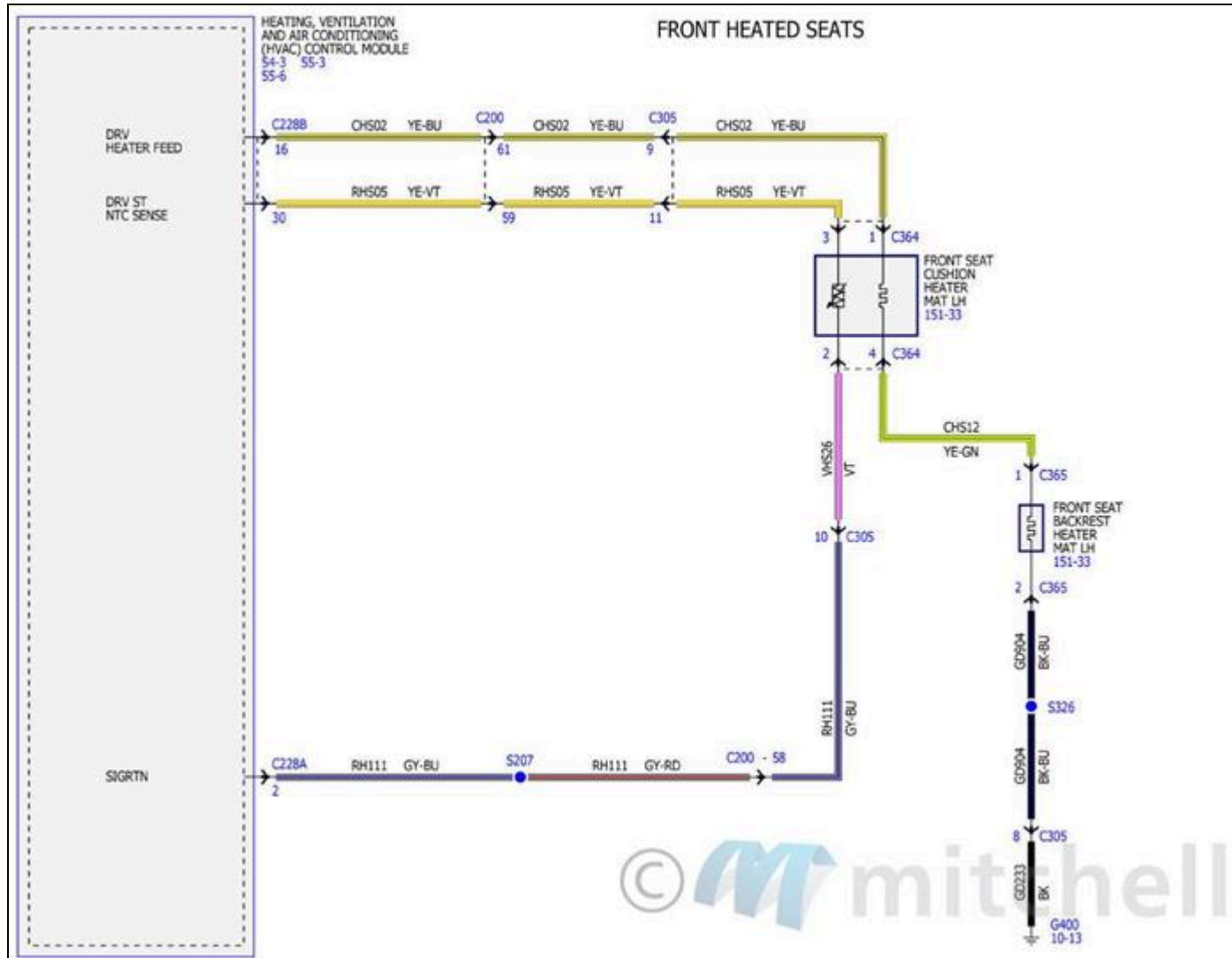

Fig. 25: Diagramas de cableado de asientos con control de clima (3 de 4)

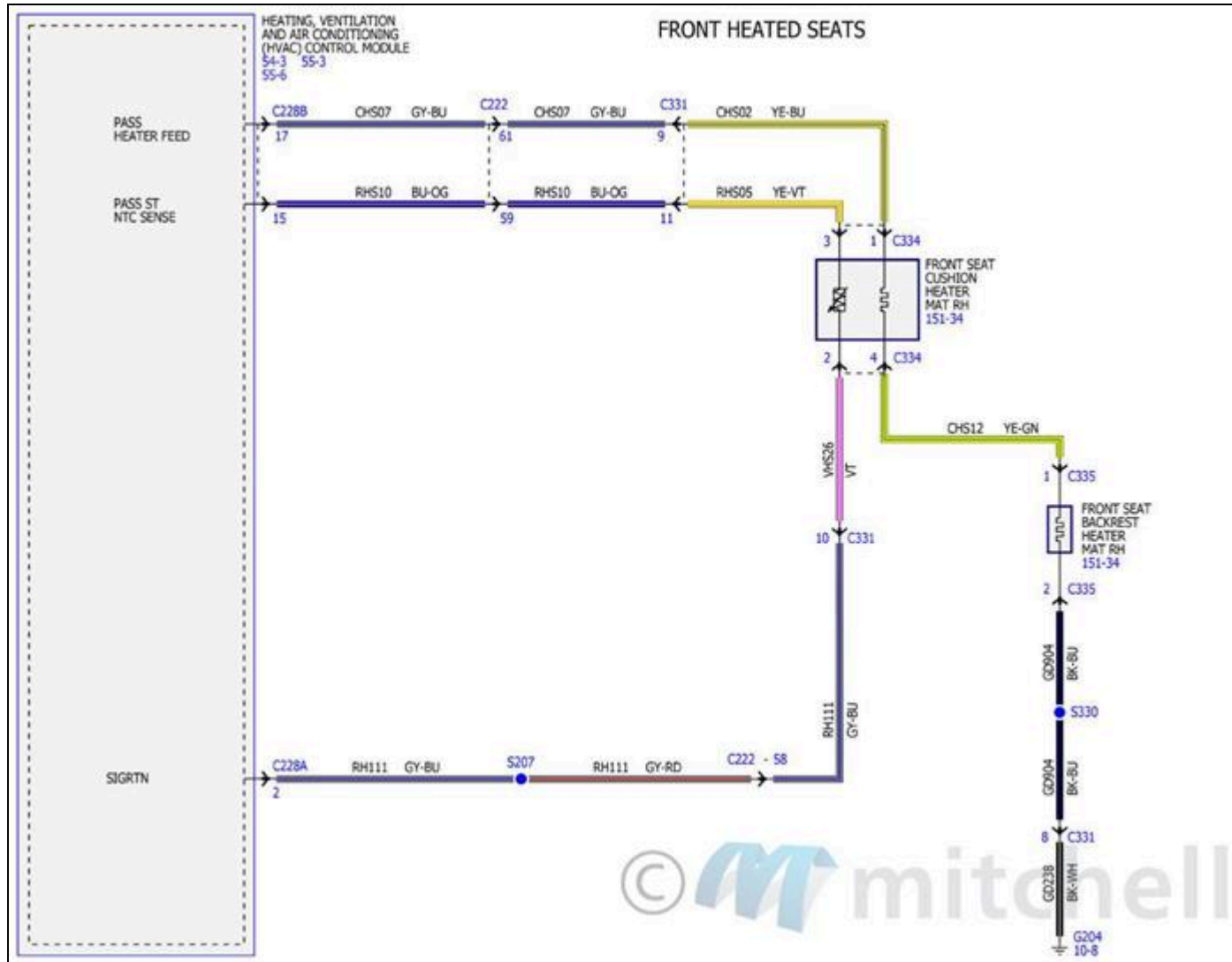
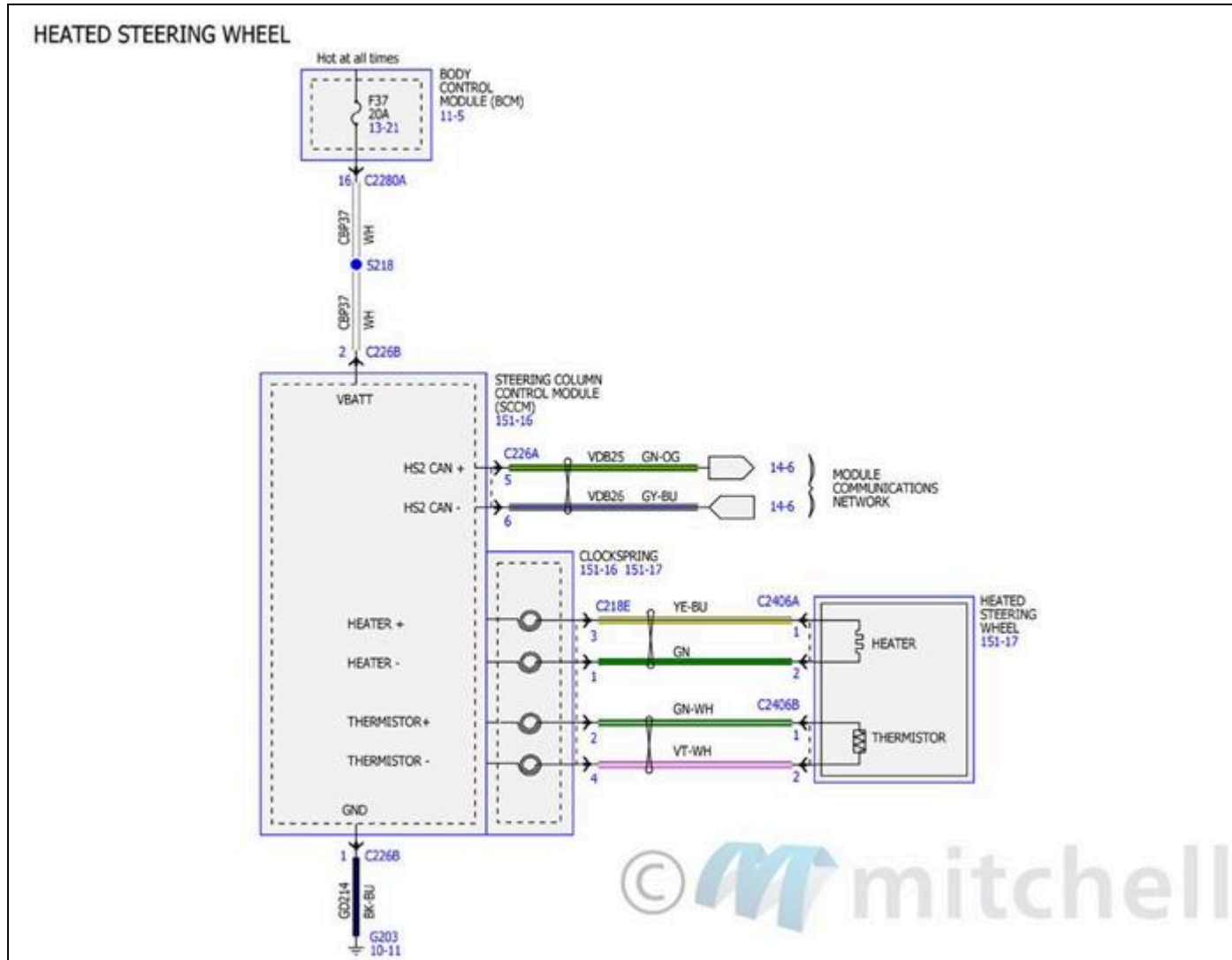

Fig. 26: Diagramas de cableado de asientos con control de clima (4 de 4)



ILUMINACIÓN DE PANELES Y GRUPOS

Fig. 27: Diagramas de cableado de iluminación de grupos y paneles (1 de 3)

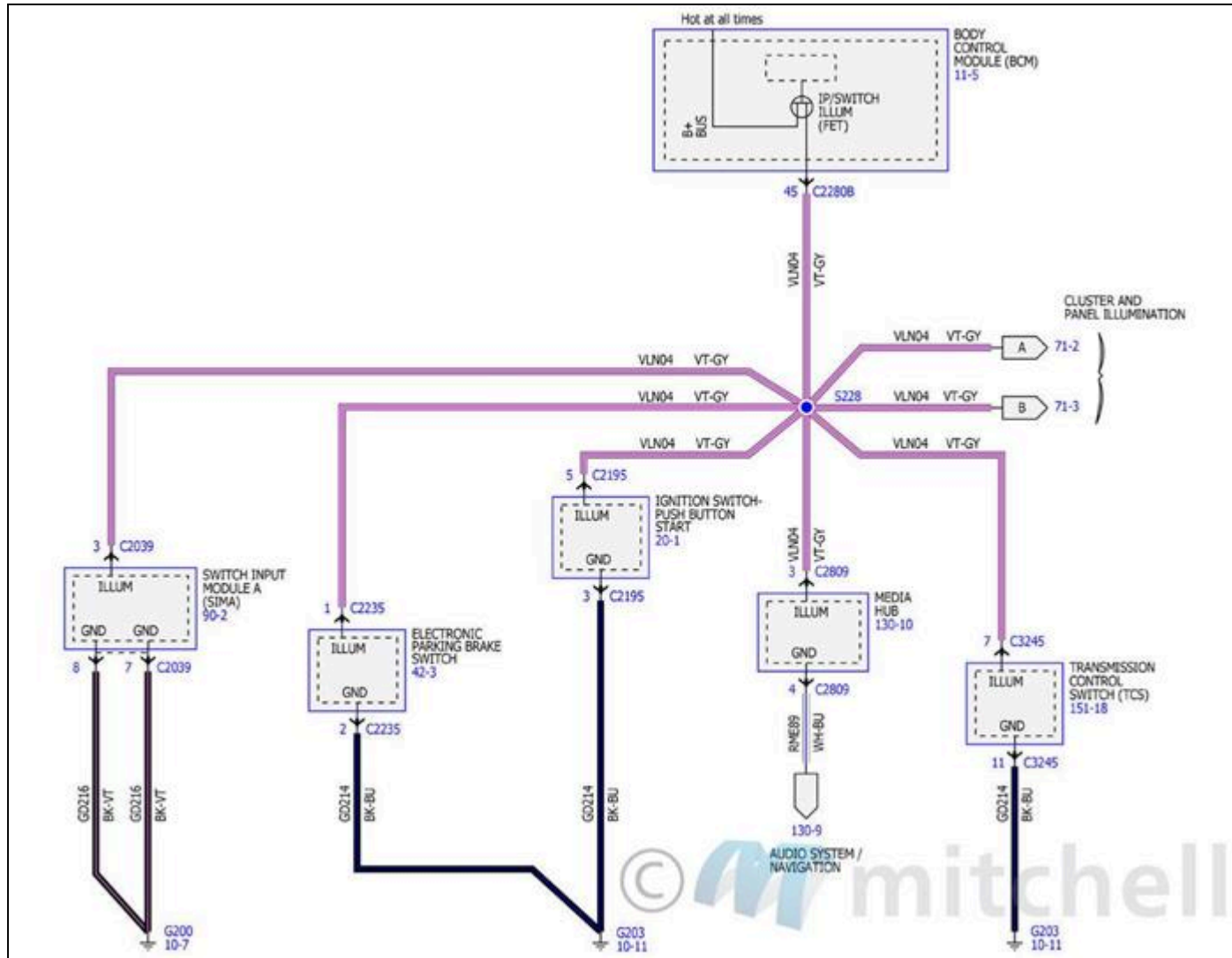

Fig. 28: Diagramas de cableado de iluminación de grupos y paneles (2 de 3)

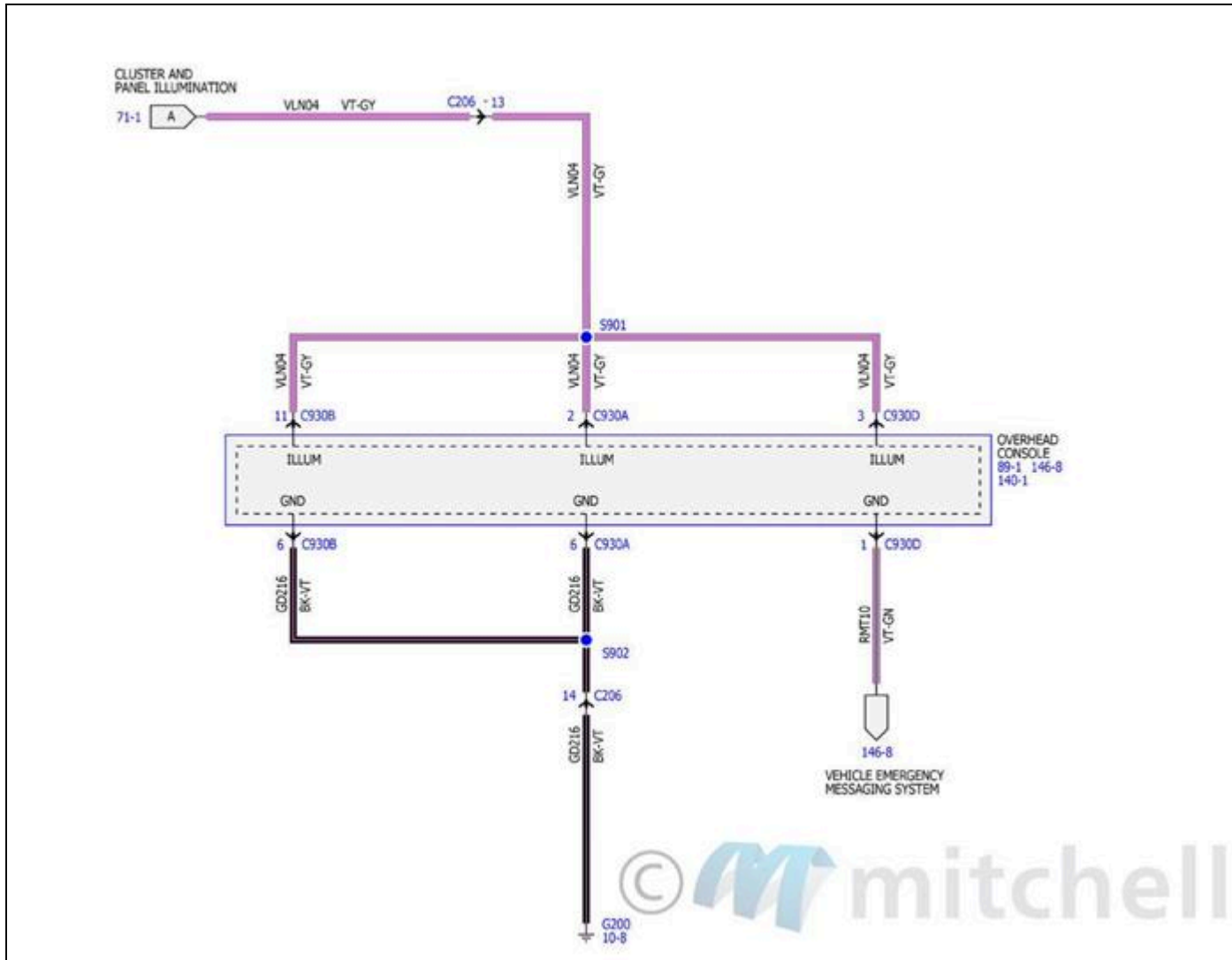
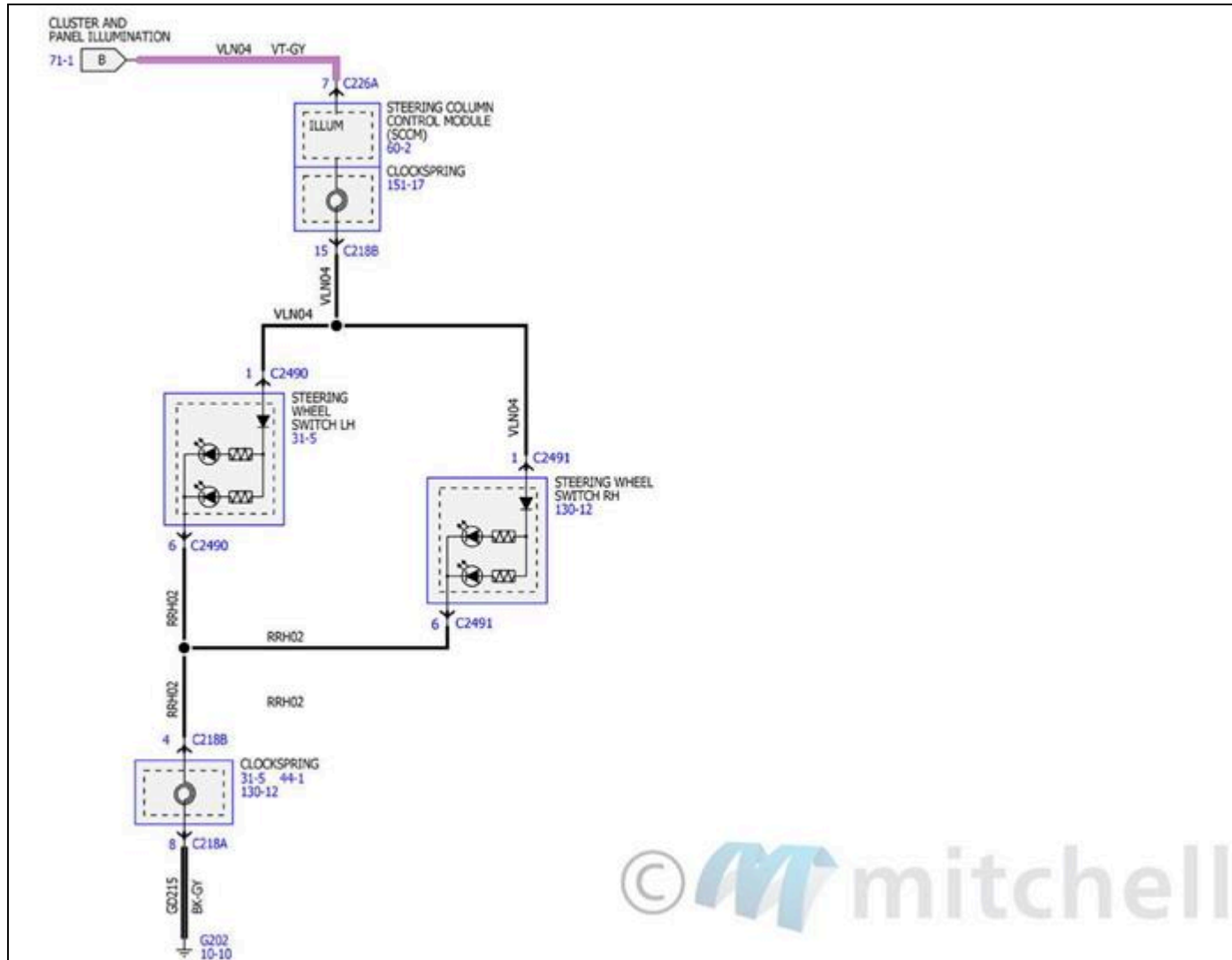

Fig. 29: Diagramas de cableado de iluminación de grupos y paneles (3 de 3)



VENTILADOR DE ENFRIAMIENTO

Fig. 30: Diagramas de cableado del ventilador de enfriamiento (1 de 2)

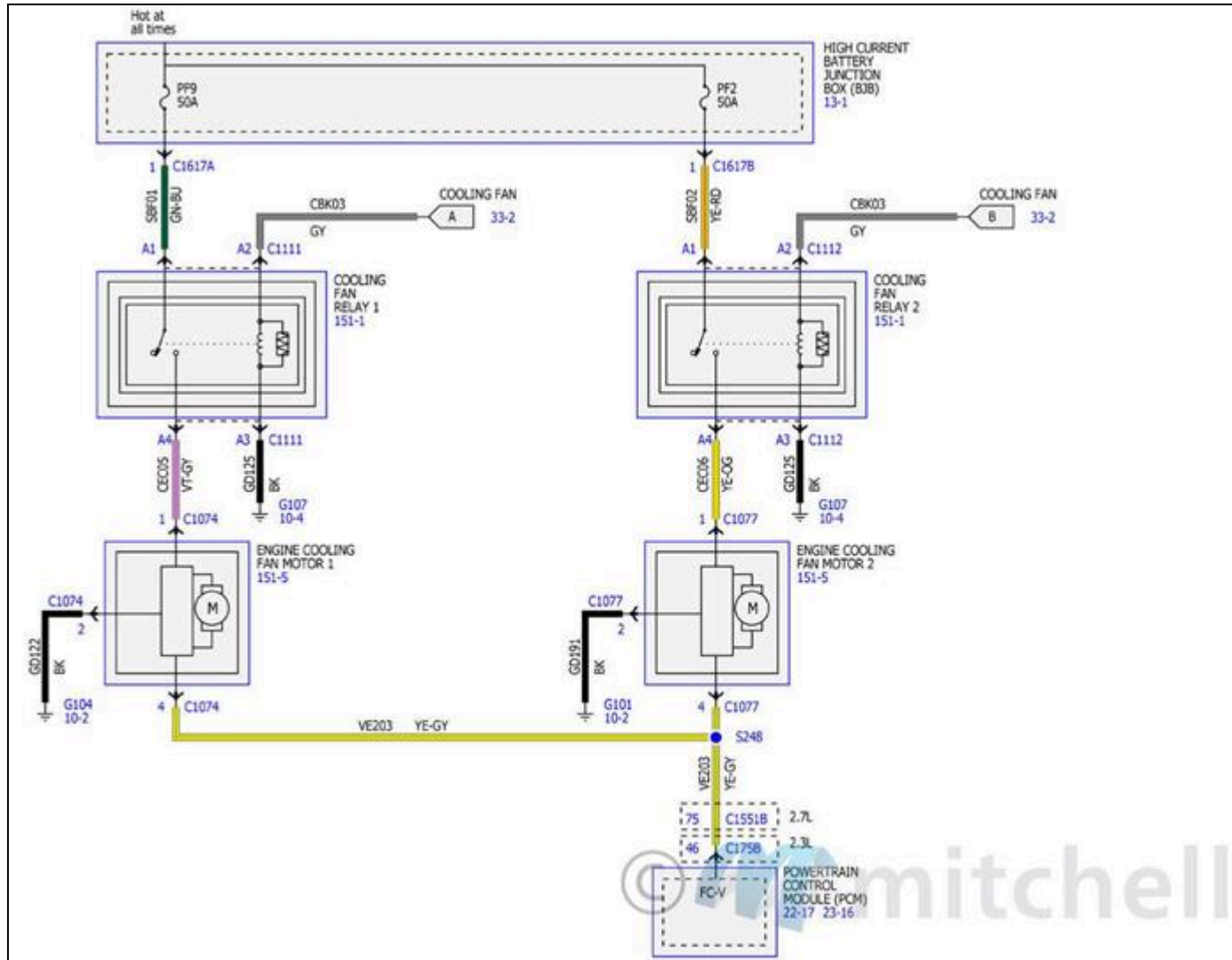
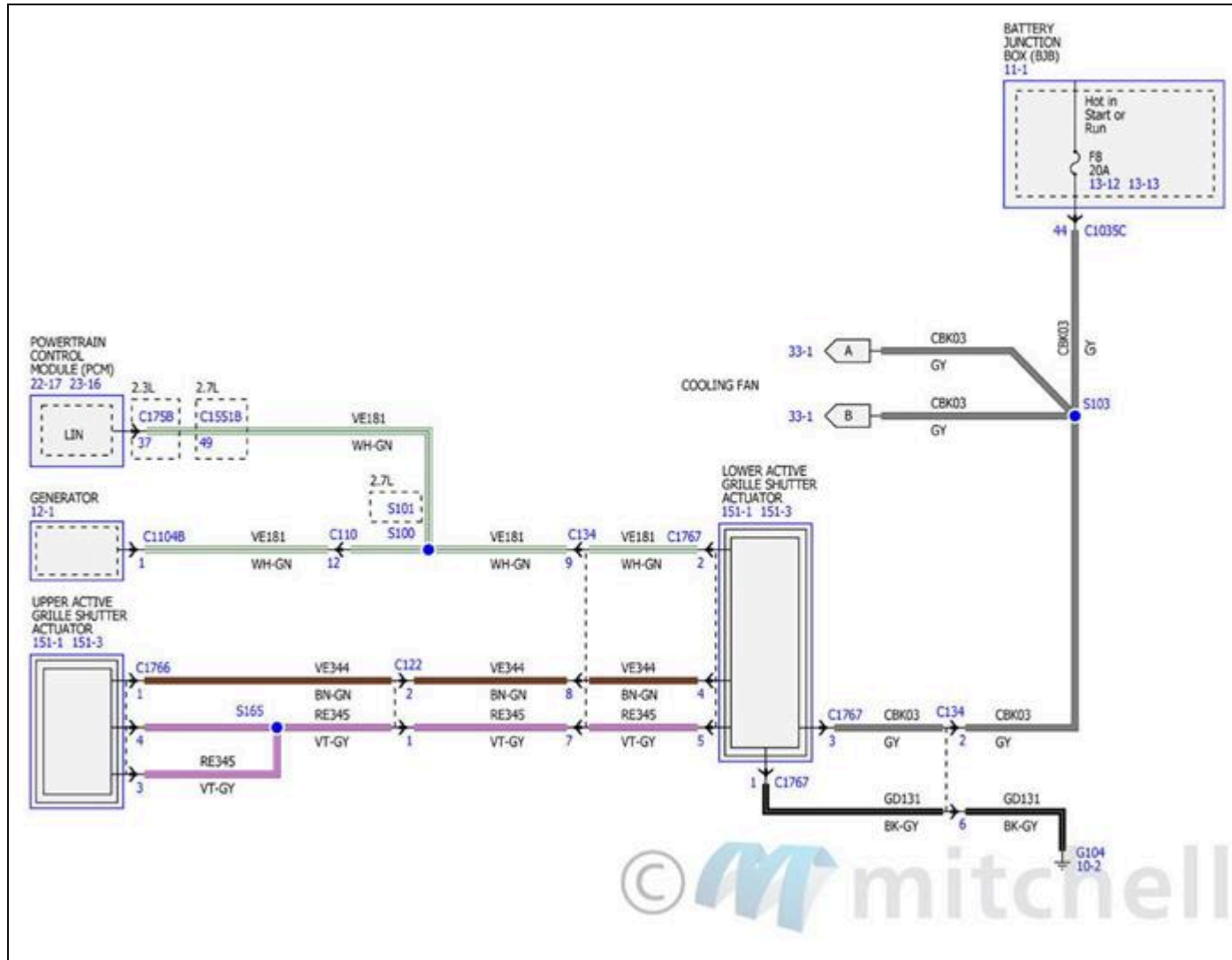

Fig. 31: Diagramas de cableado del ventilador de enfriamiento (2 de 2)



CONTROL DE CRUCERO

Fig. 32: Diagramas de cableado del control de crucero (1 de 7)

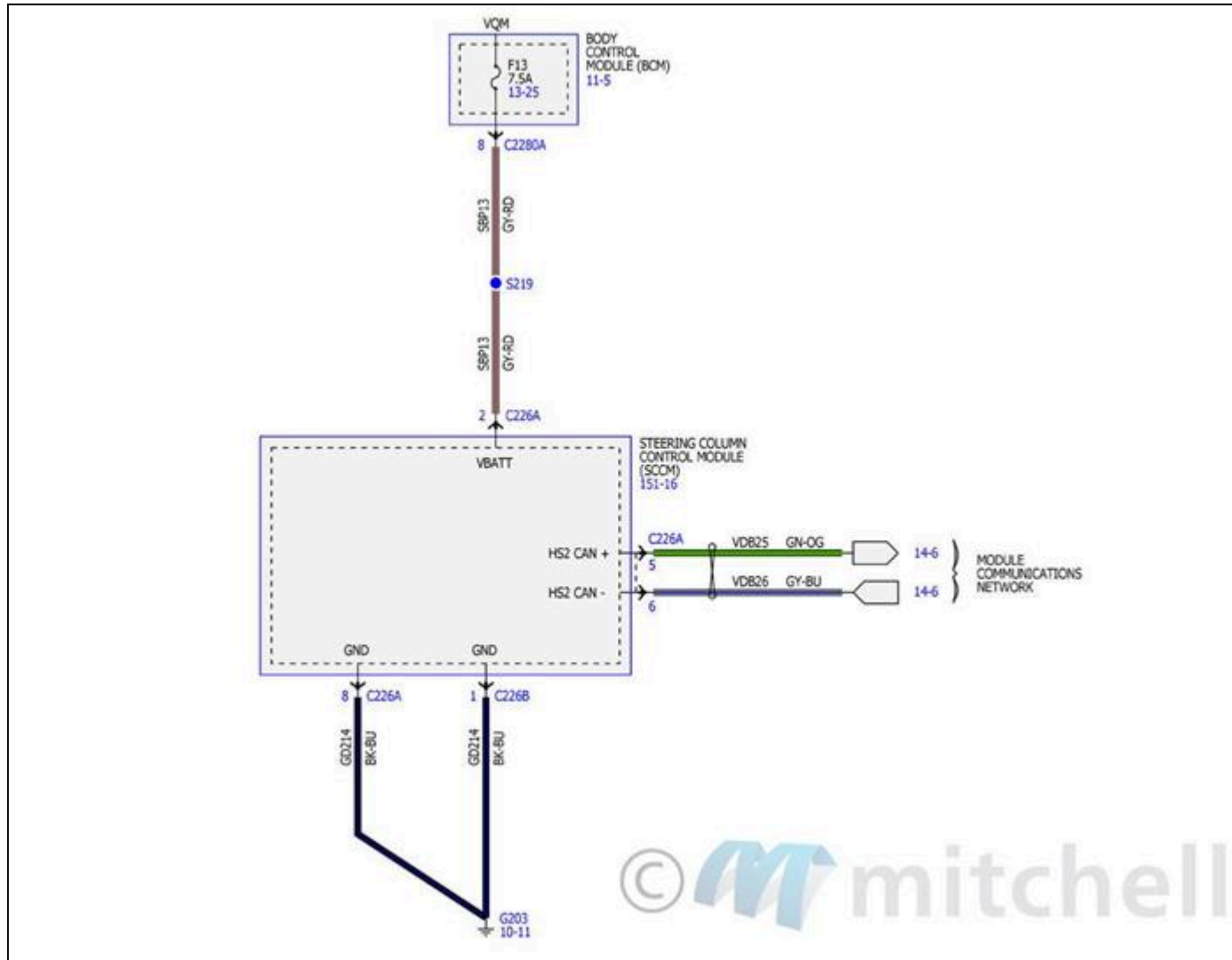

Fig. 33: Diagramas de cableado del control de crucero (2 de 7)

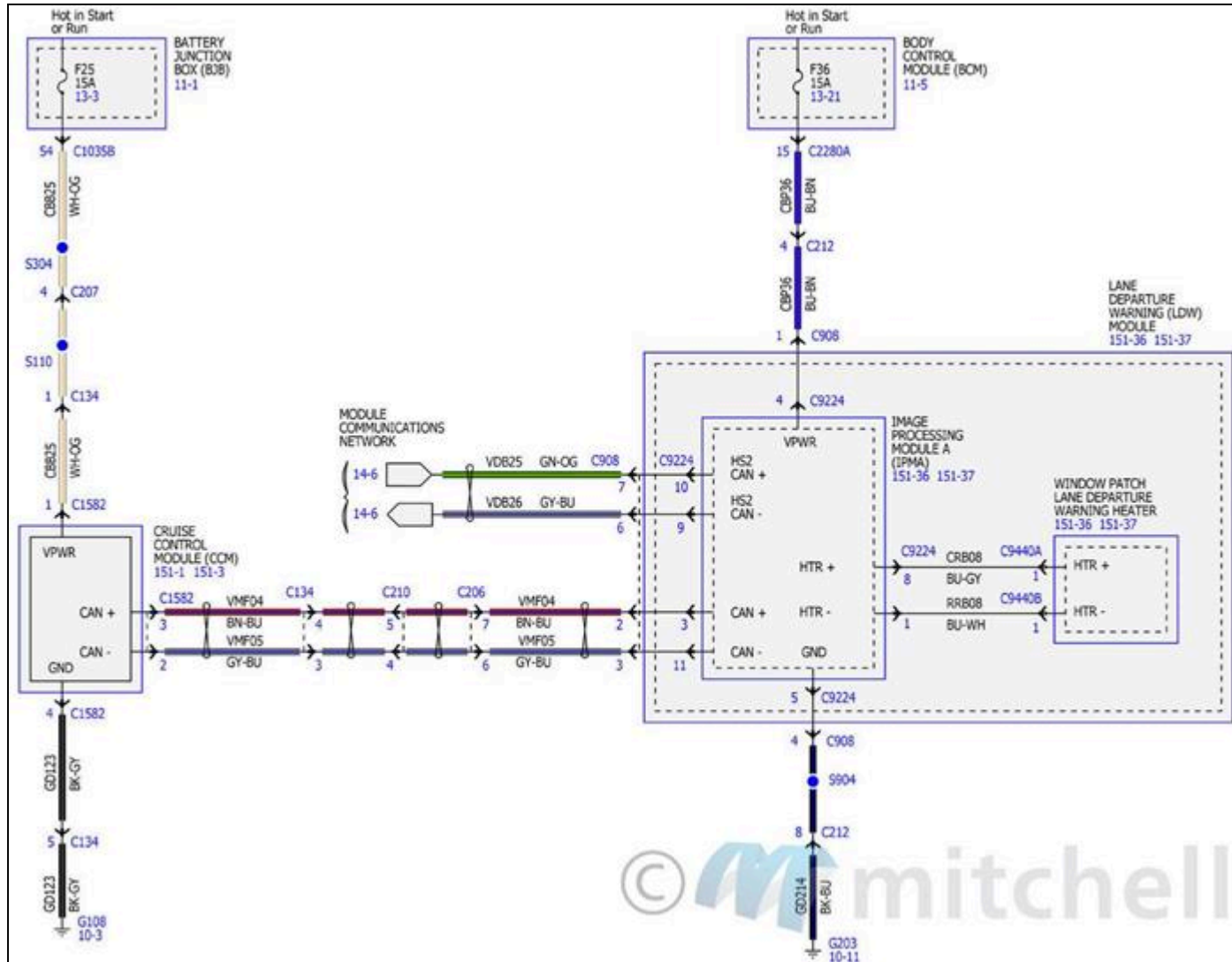

Fig. 34: Diagramas de cableado del control de cruceo (3 de 7)

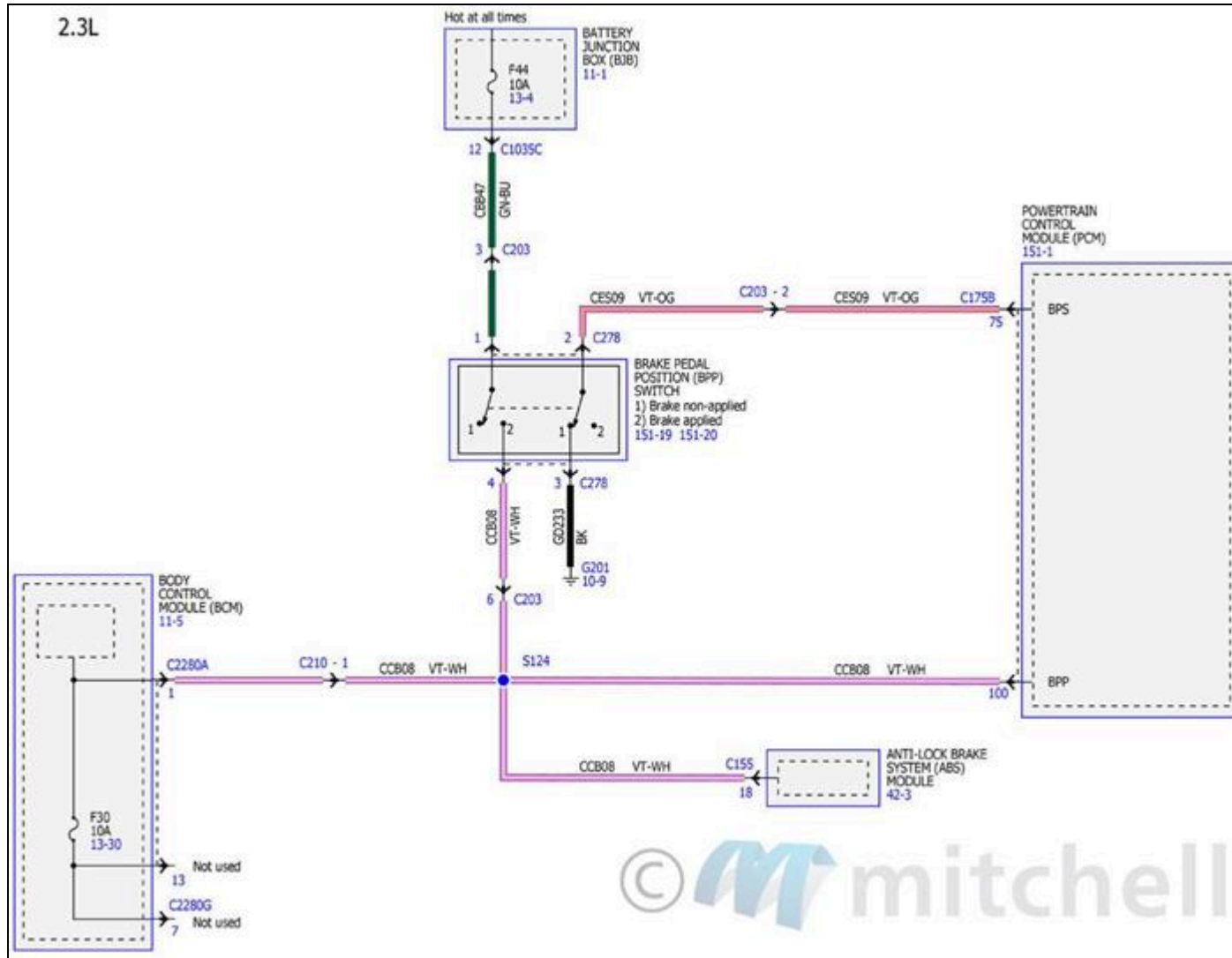

Fig. 35: Diagramas de cableado del control de crucero (4 de 7)

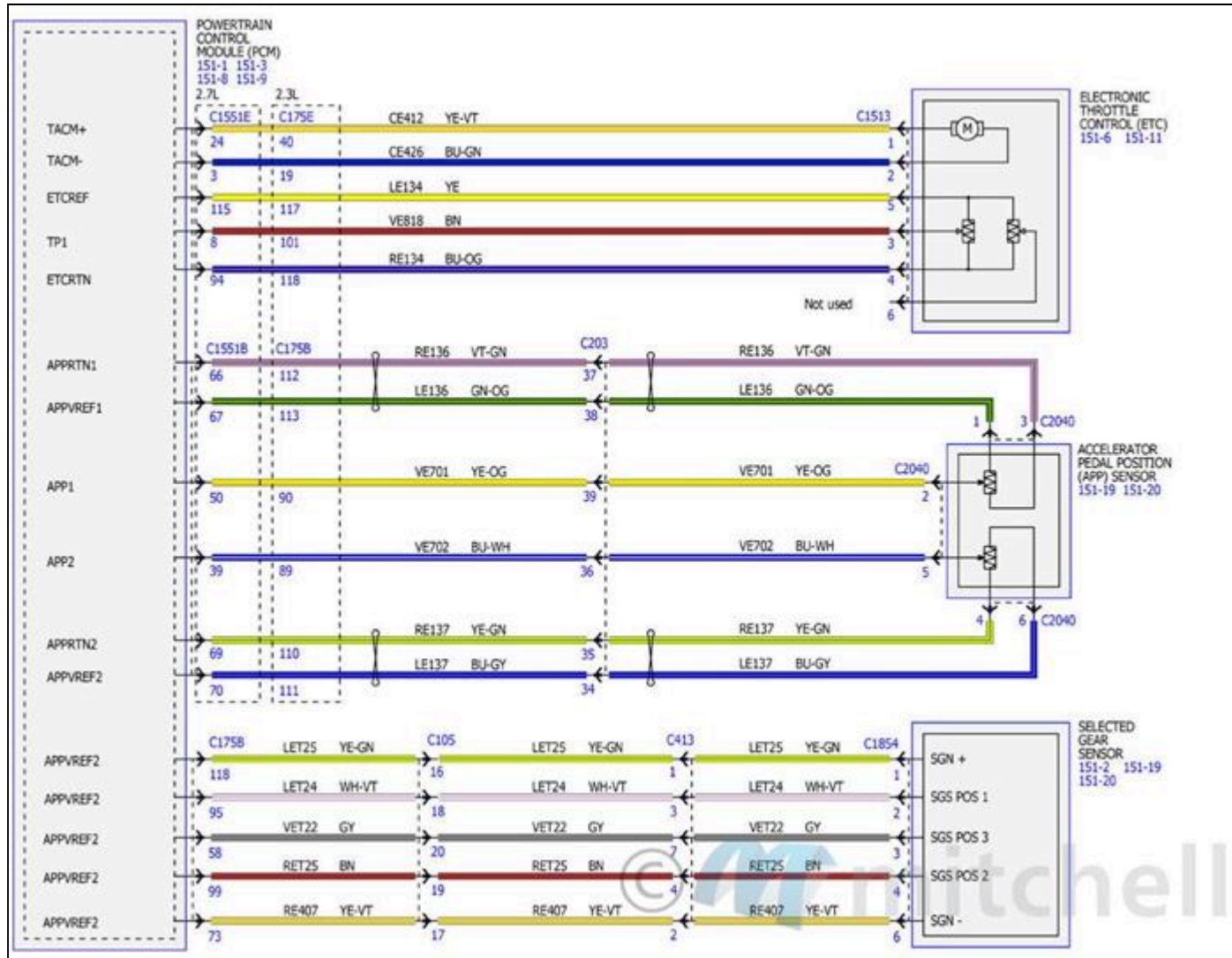

Fig. 36: Diagramas de cableado del control de cruceo (5 de 7)

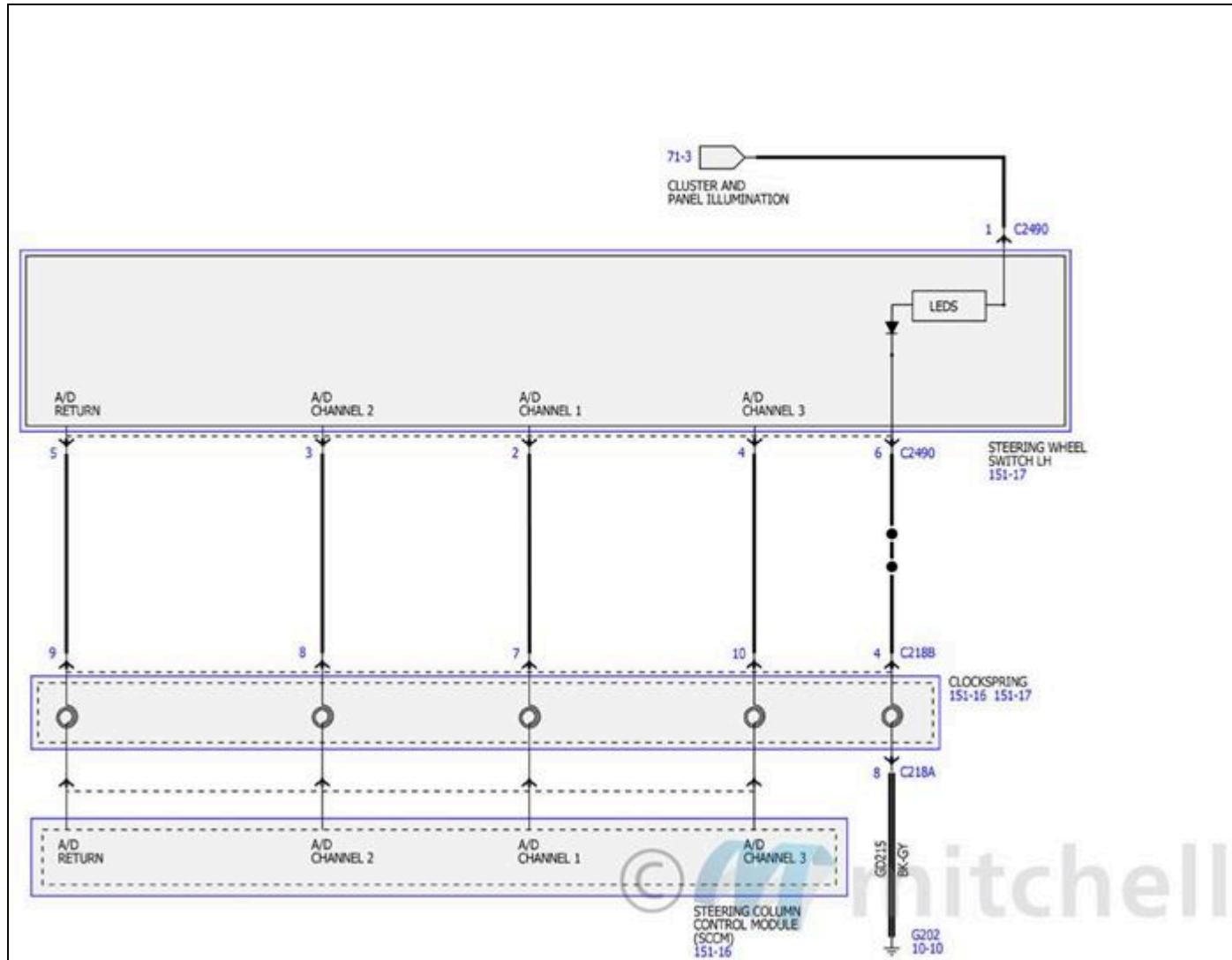

Fig. 37: Diagramas de cableado del control de crucero (6 de 7)

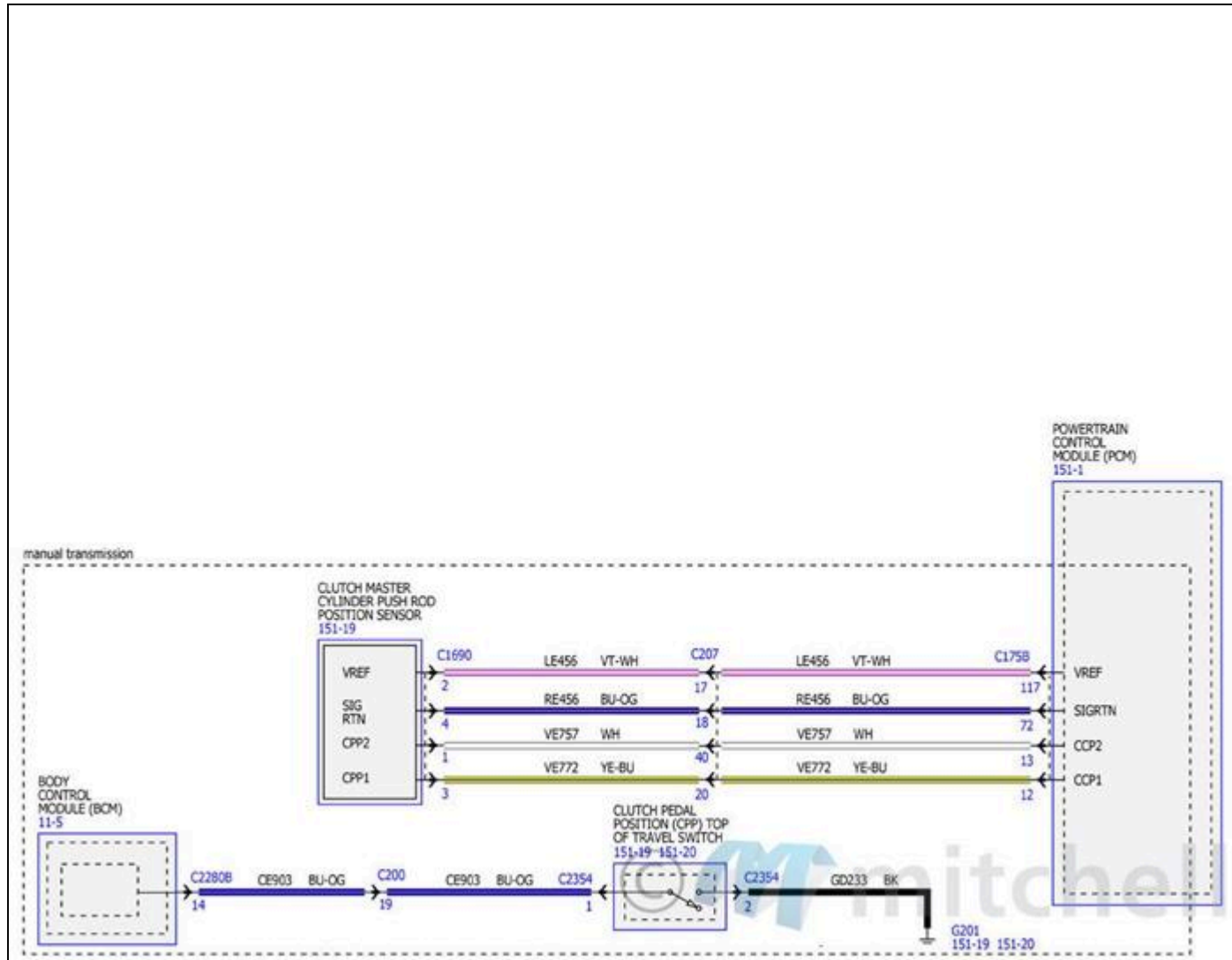
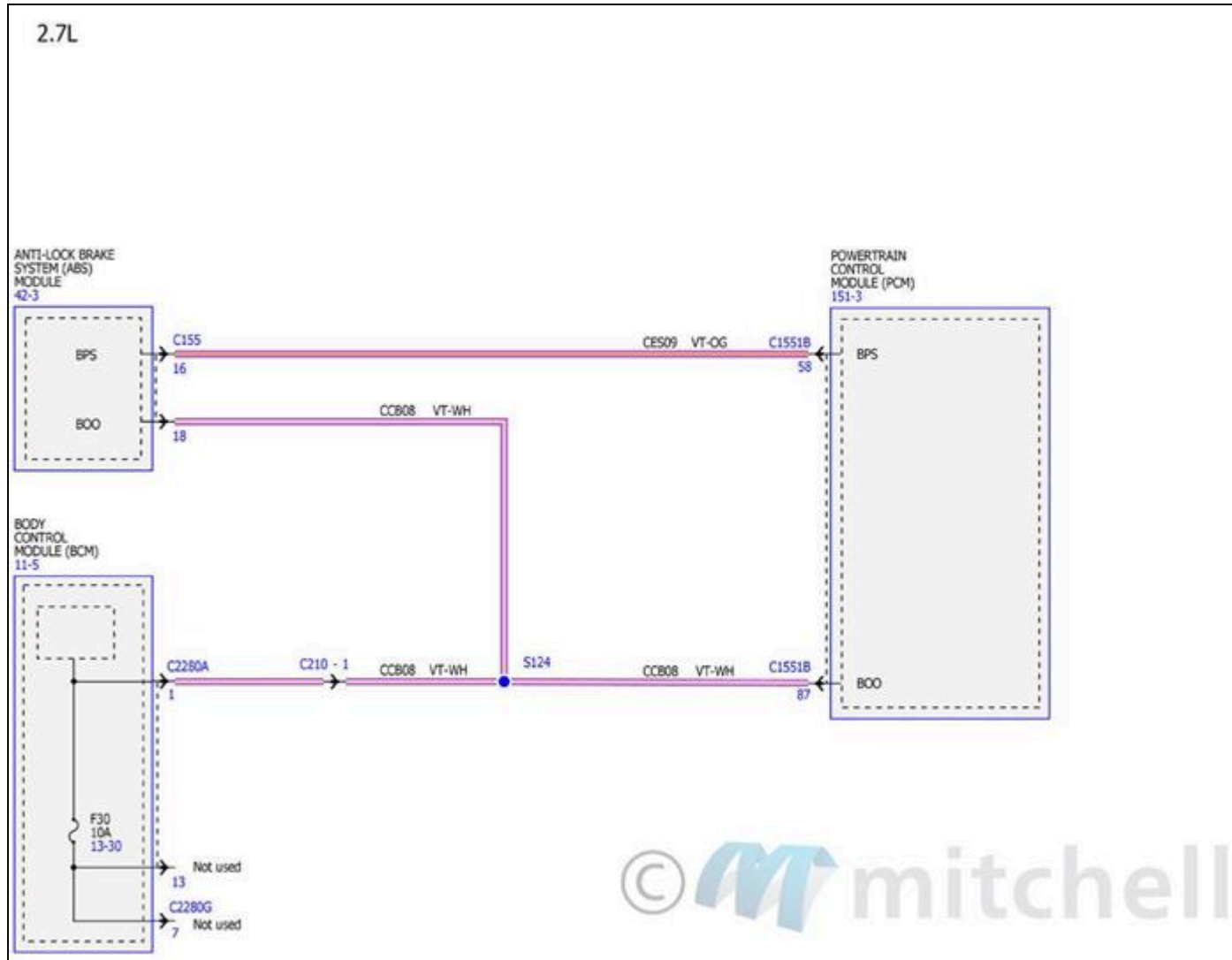

Fig. 38: Diagramas de cableado del control de crucero (7 de 7)



ACCESO DE CLIENTES

Fig. 39: Diagramas de cableado de acceso del cliente (1 de 4)

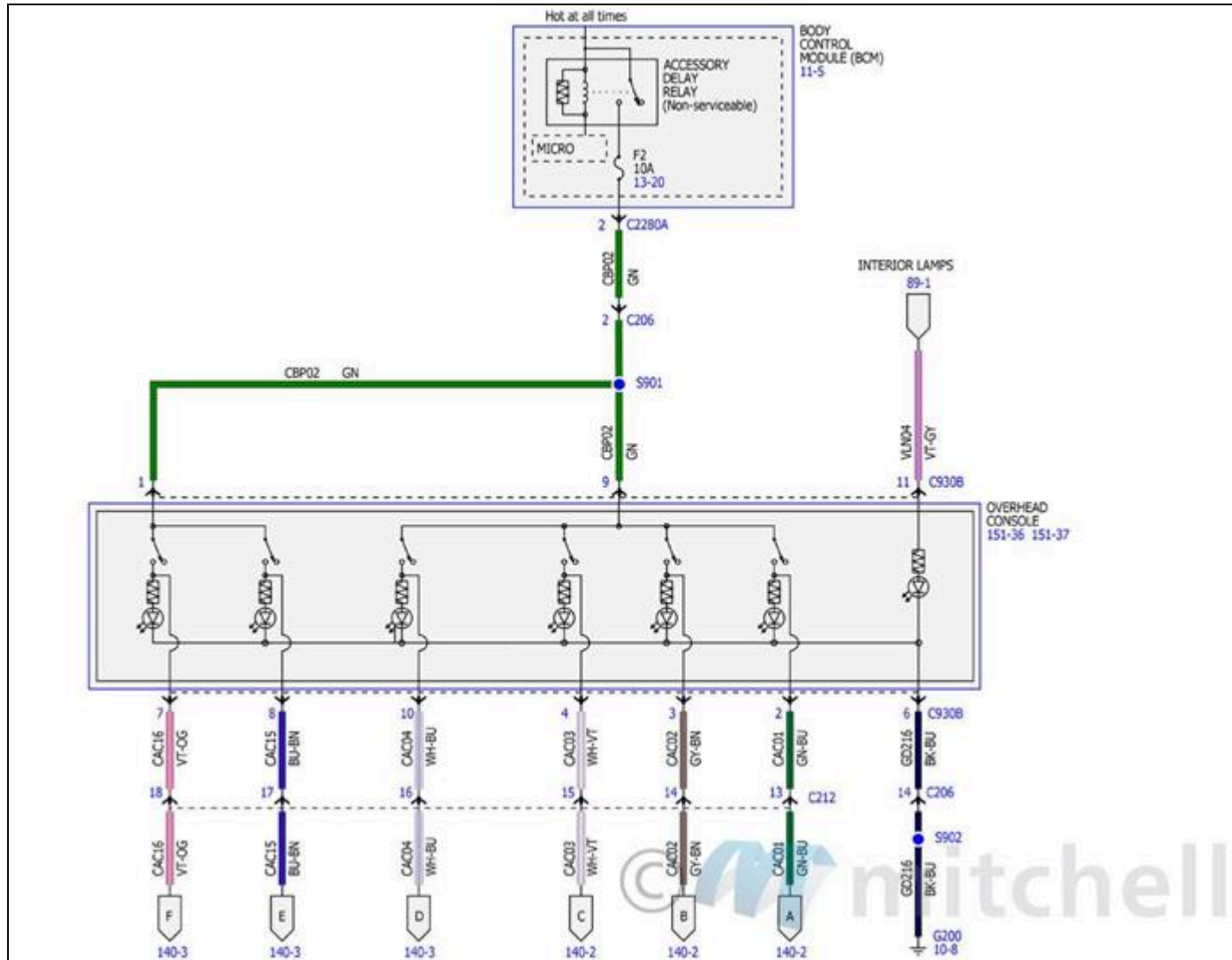

Fig. 40: Diagramas de cableado de acceso del cliente (2 de 4)

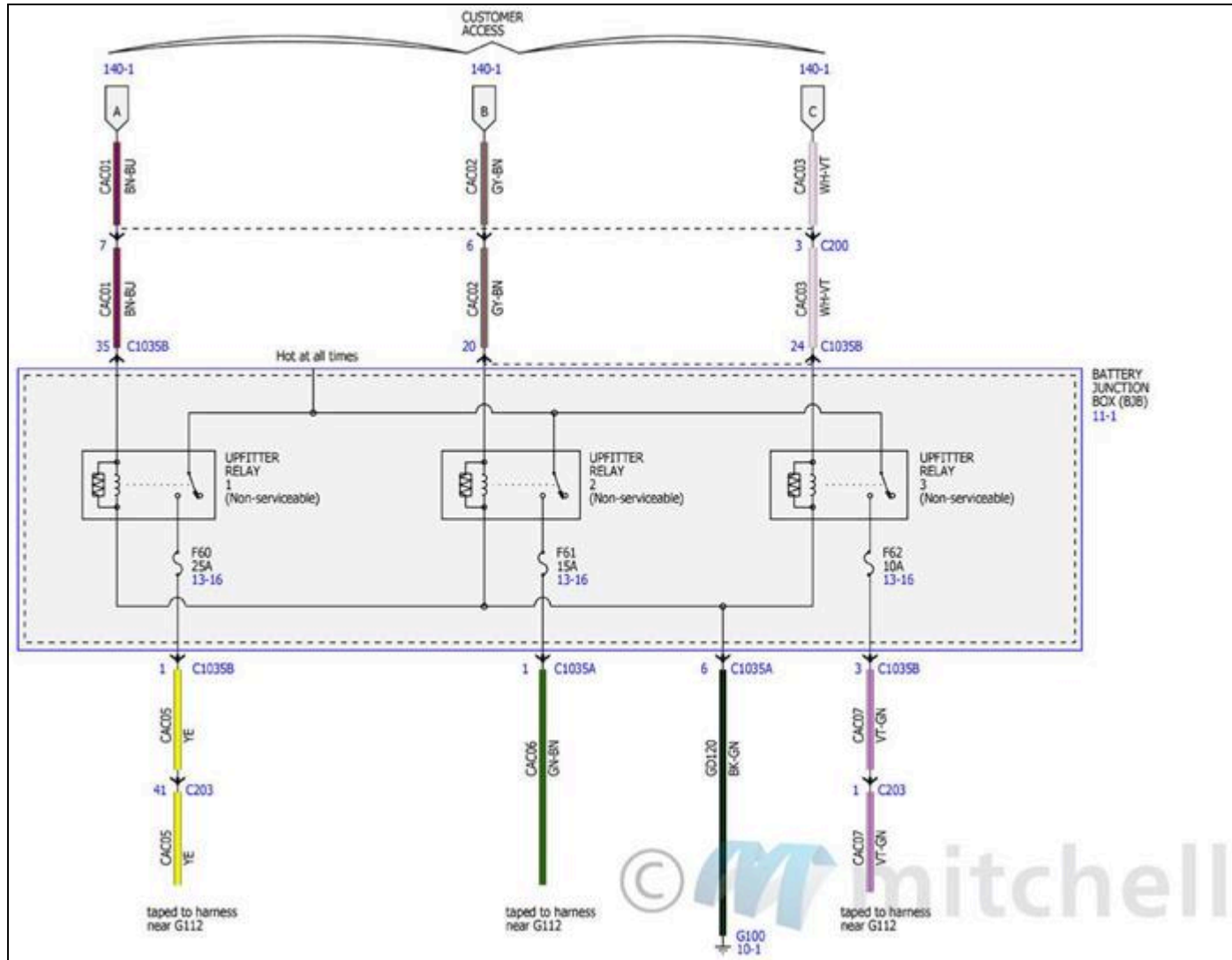

Fig. 41: Diagramas de cableado de acceso del cliente (3 de 4)

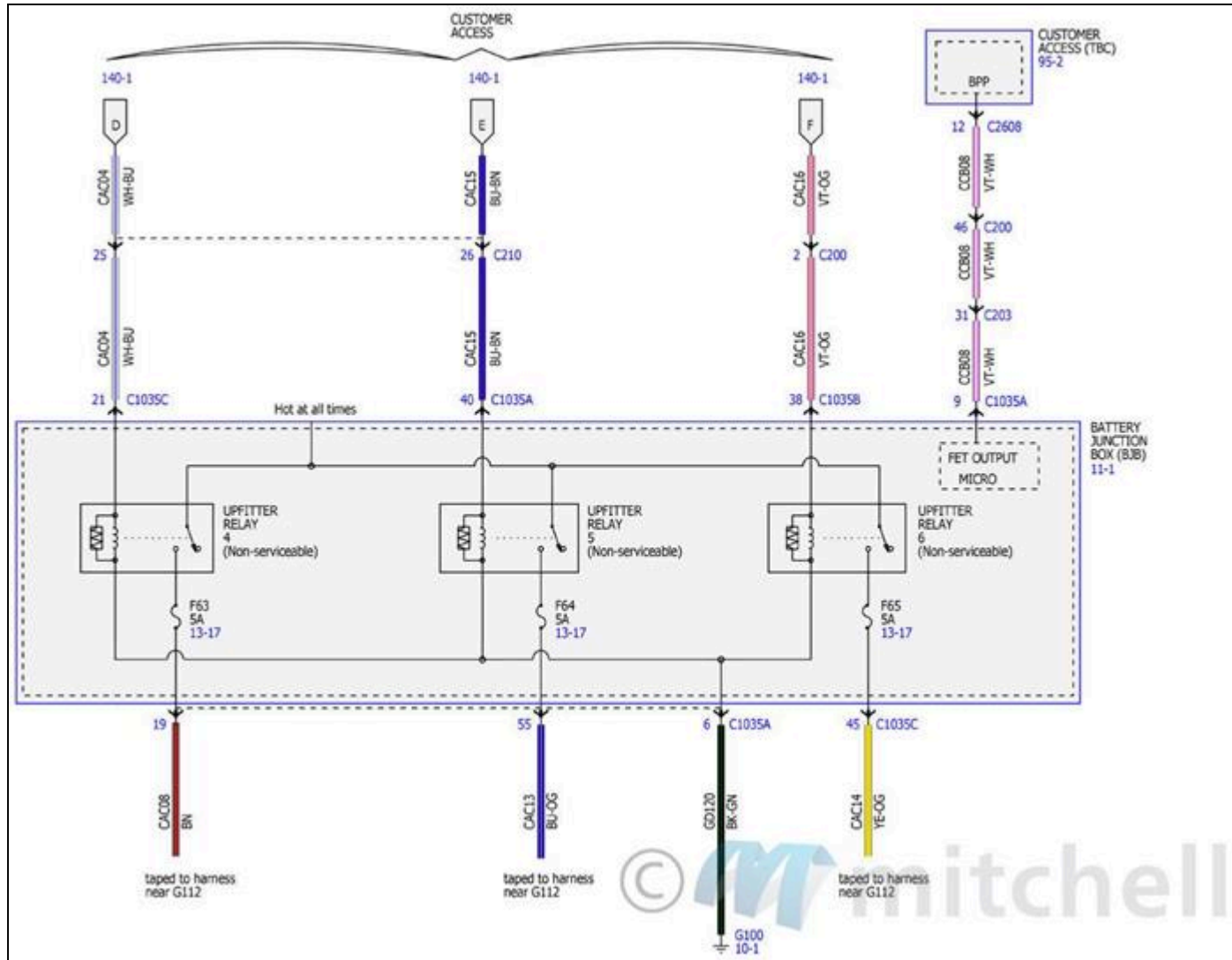
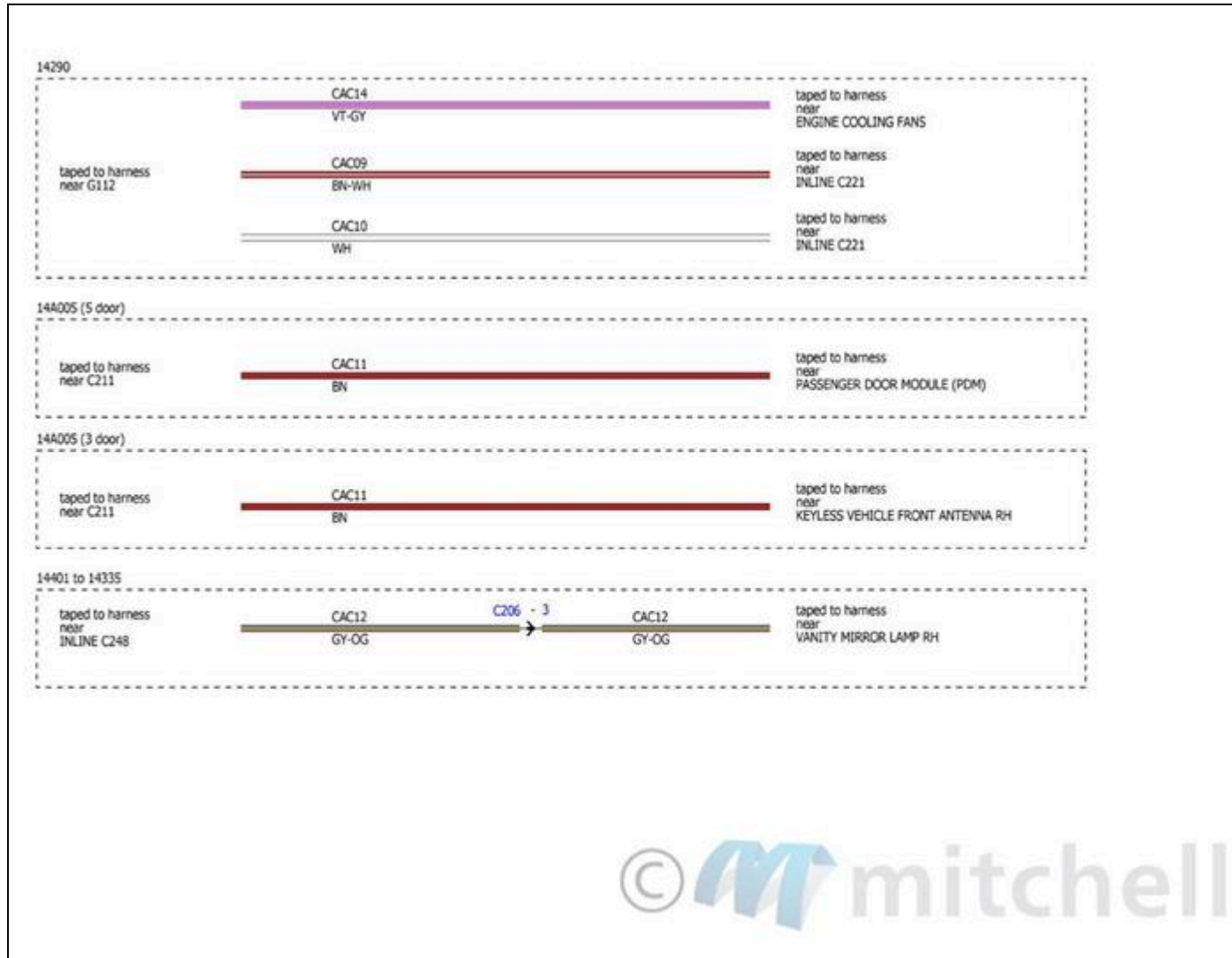

Fig. 42: Diagramas de cableado de acceso del cliente (4 de 4)



CONTROLES ELECTRÓNICOS DEL MOTOR - 2.3L

Fig. 43: Diagramas de cableado de los controles electrónicos del motor - 2.3L (1 de 17)

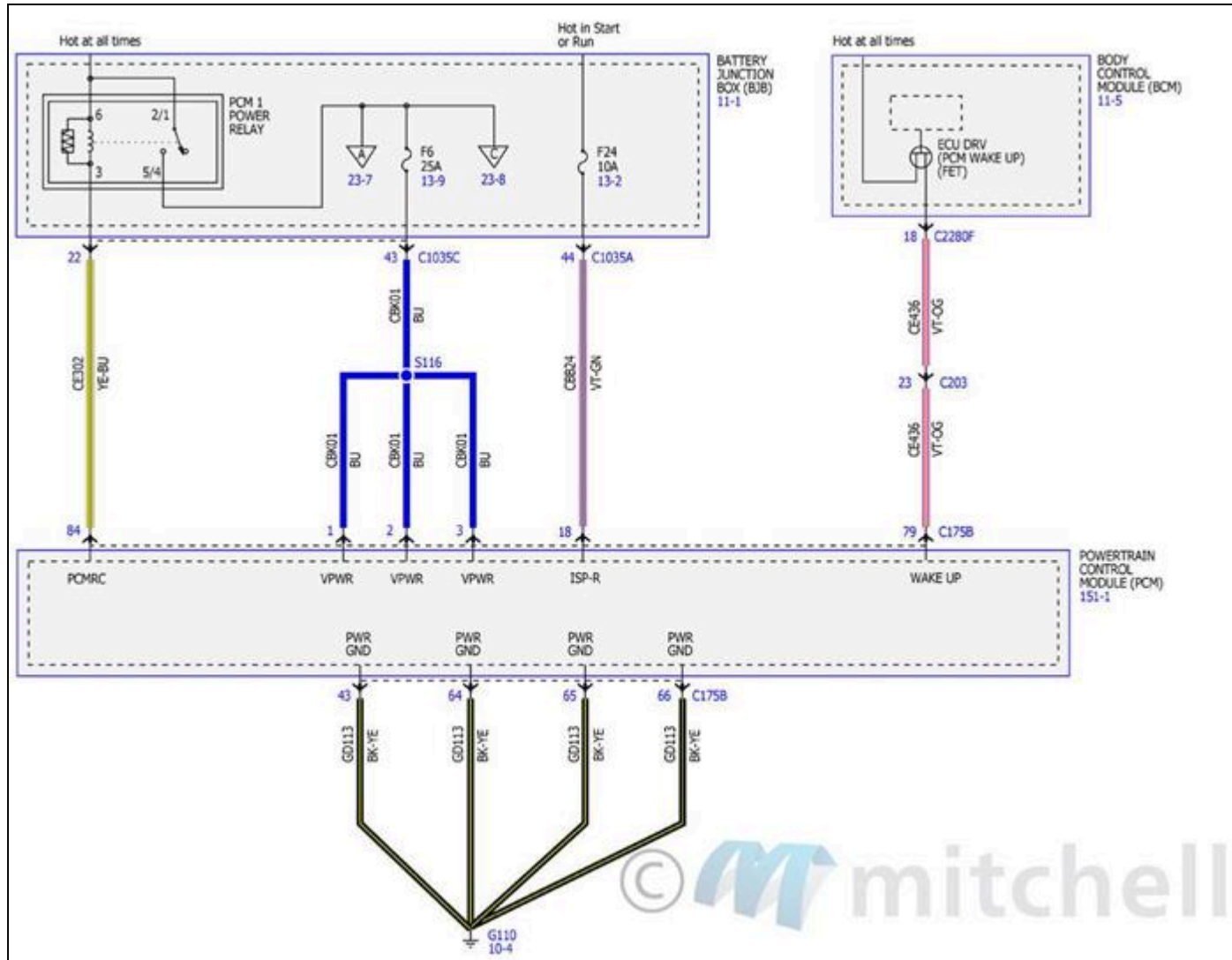

Fig. 44: Diagramas de cableado de los controles electrónicos del motor - 2.3L (2 de 17)

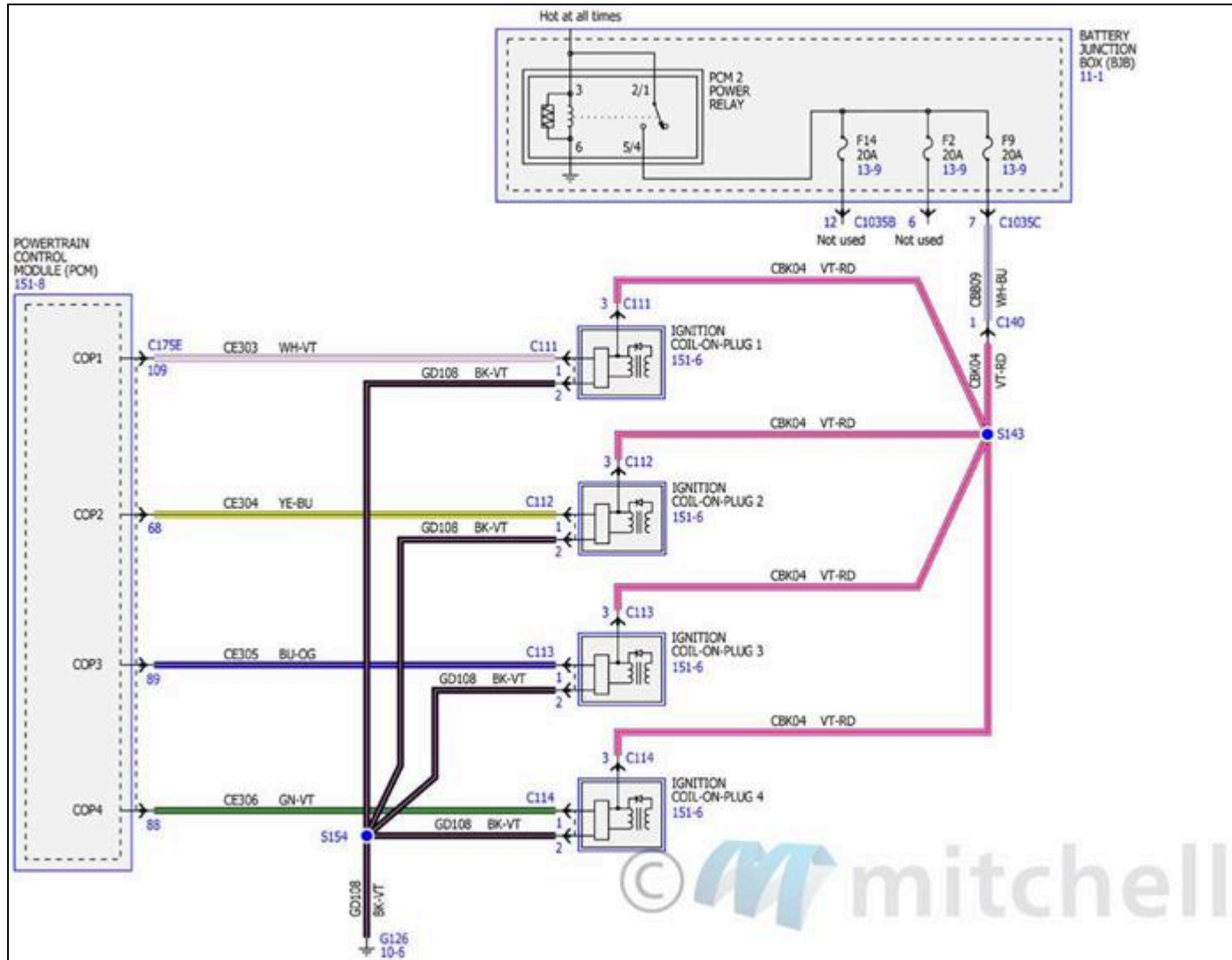

Fig. 45: Diagramas de cableado de los controles electrónicos del motor - 2.3L (3 de 17)

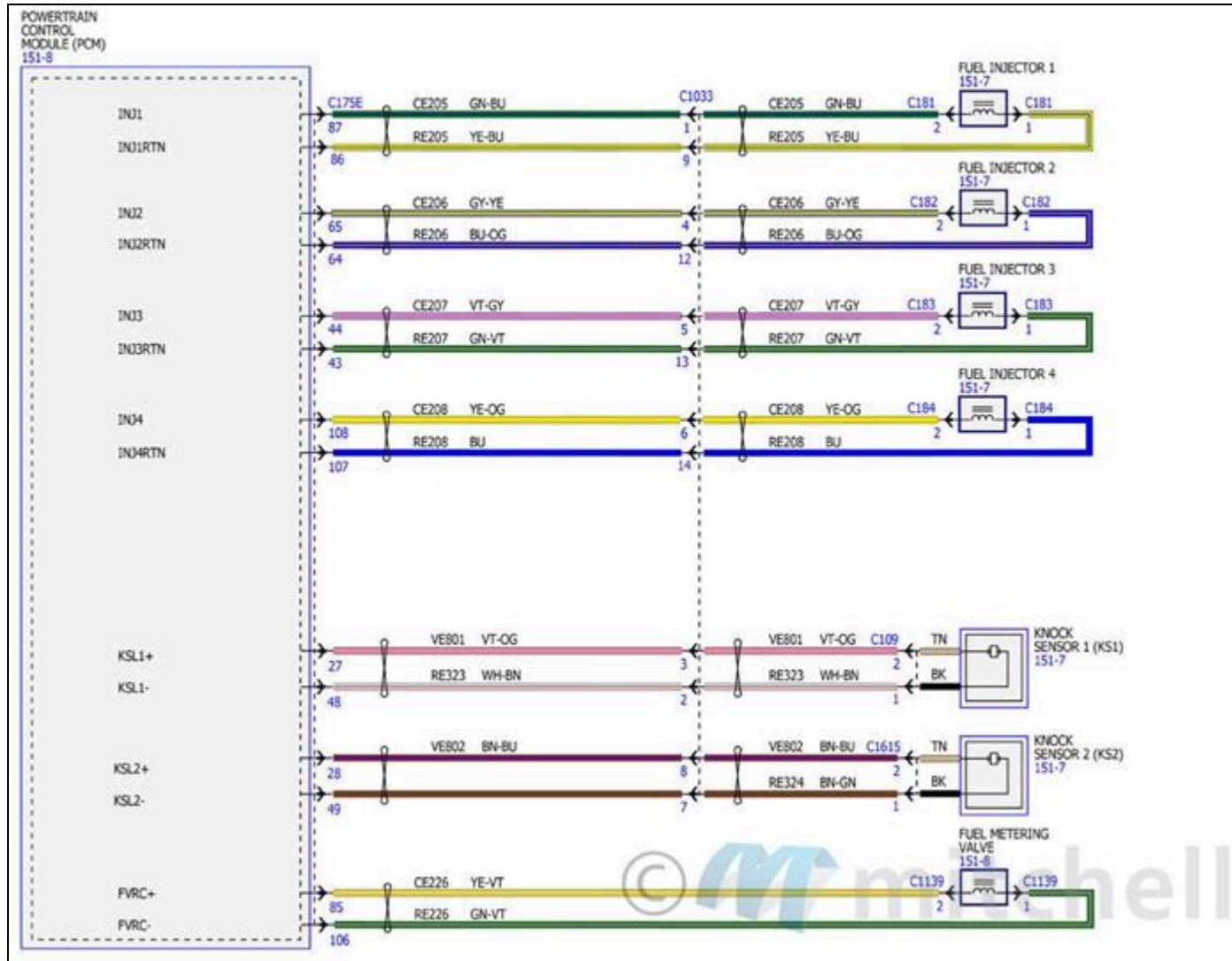

Fig. 46: Diagramas de cableado de los controles electrónicos del motor - 2.3L (4 de 17)

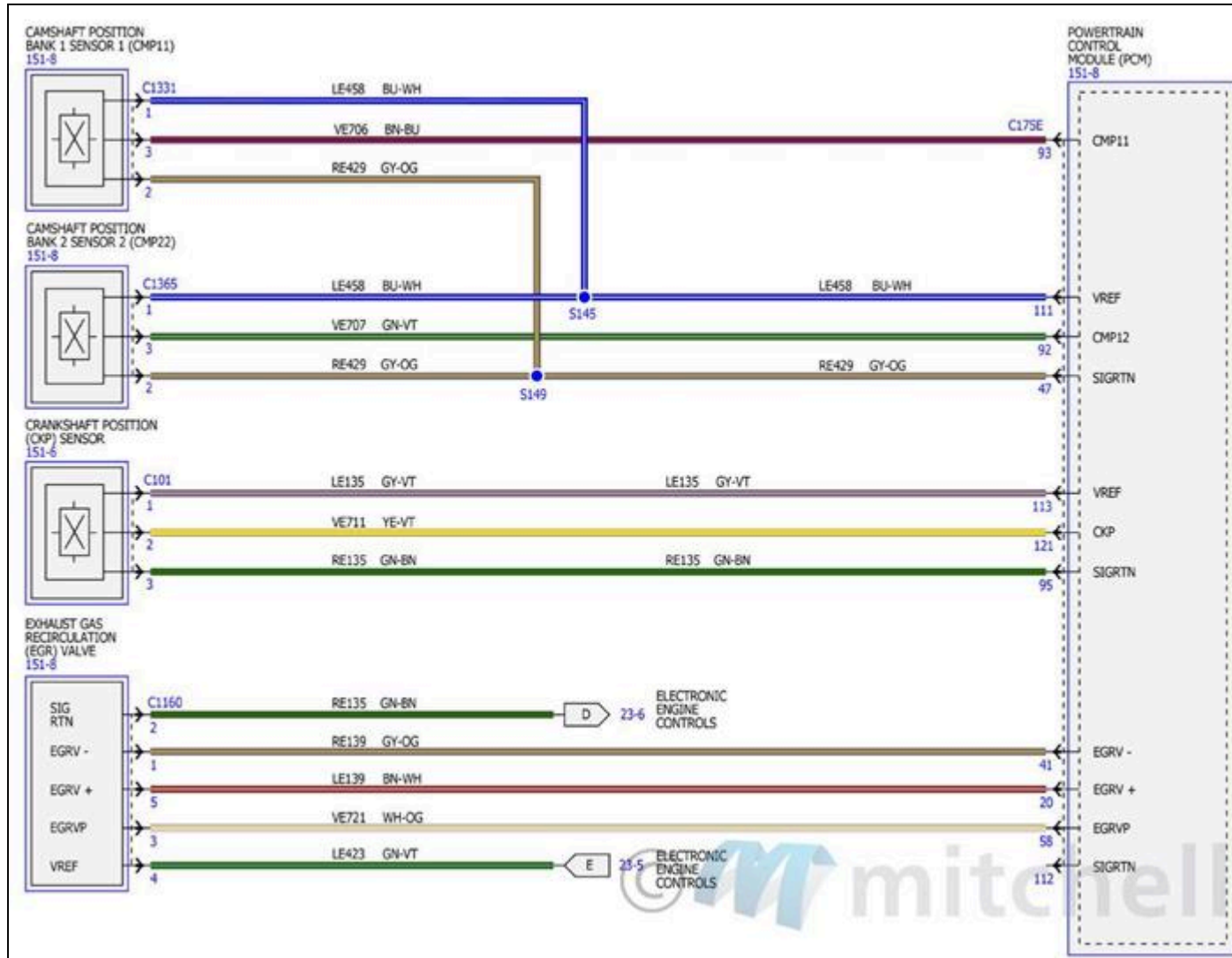

Fig. 47: Diagramas de cableado de los controles electrónicos del motor - 2.3L (5 de 17)

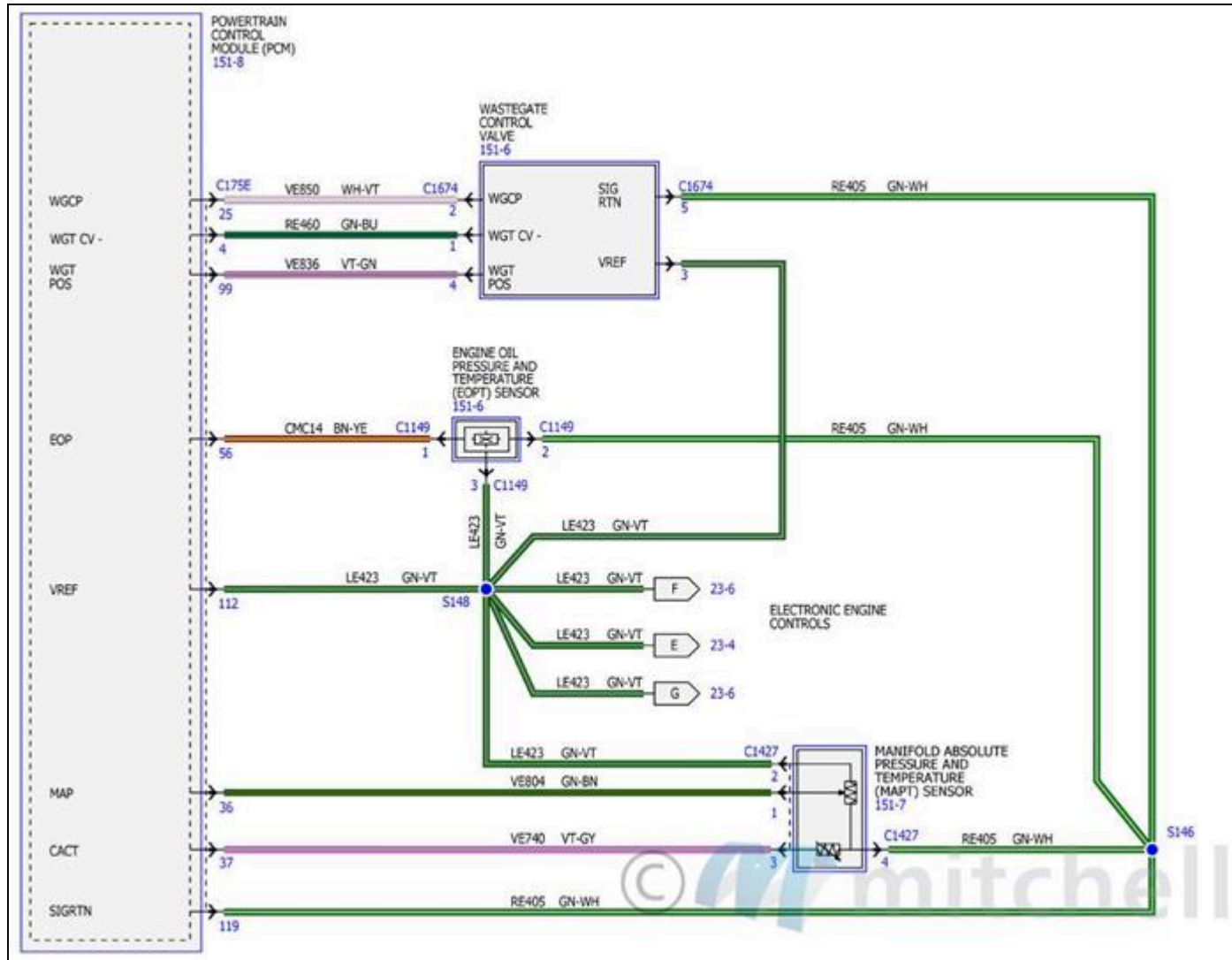

Fig. 48: Diagramas de cableado de los controles electrónicos del motor - 2.3L (6 de 17)

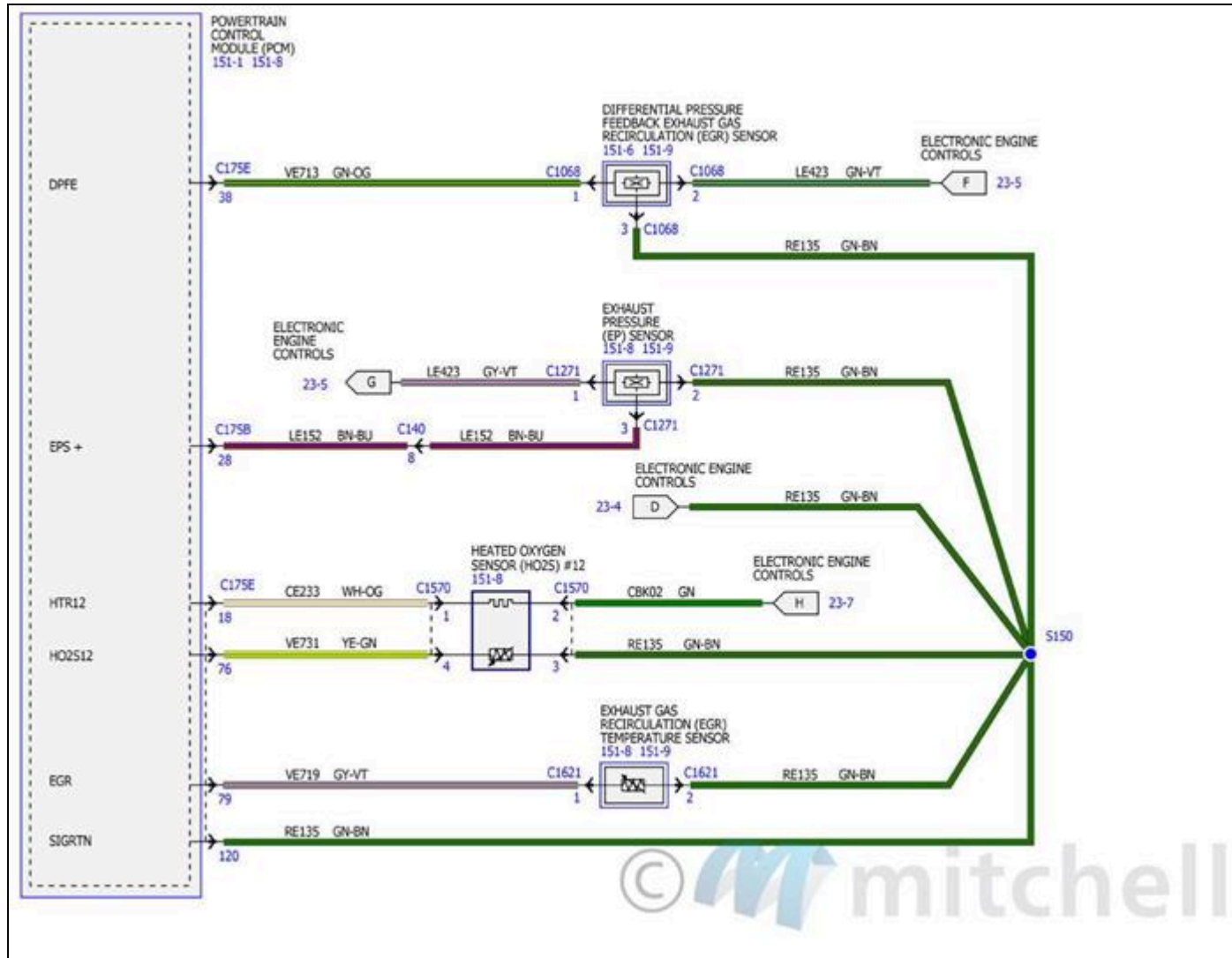

Fig. 49: Electronic Engine Controls Wiring Diagrams - 2.3L (7 Of 17)

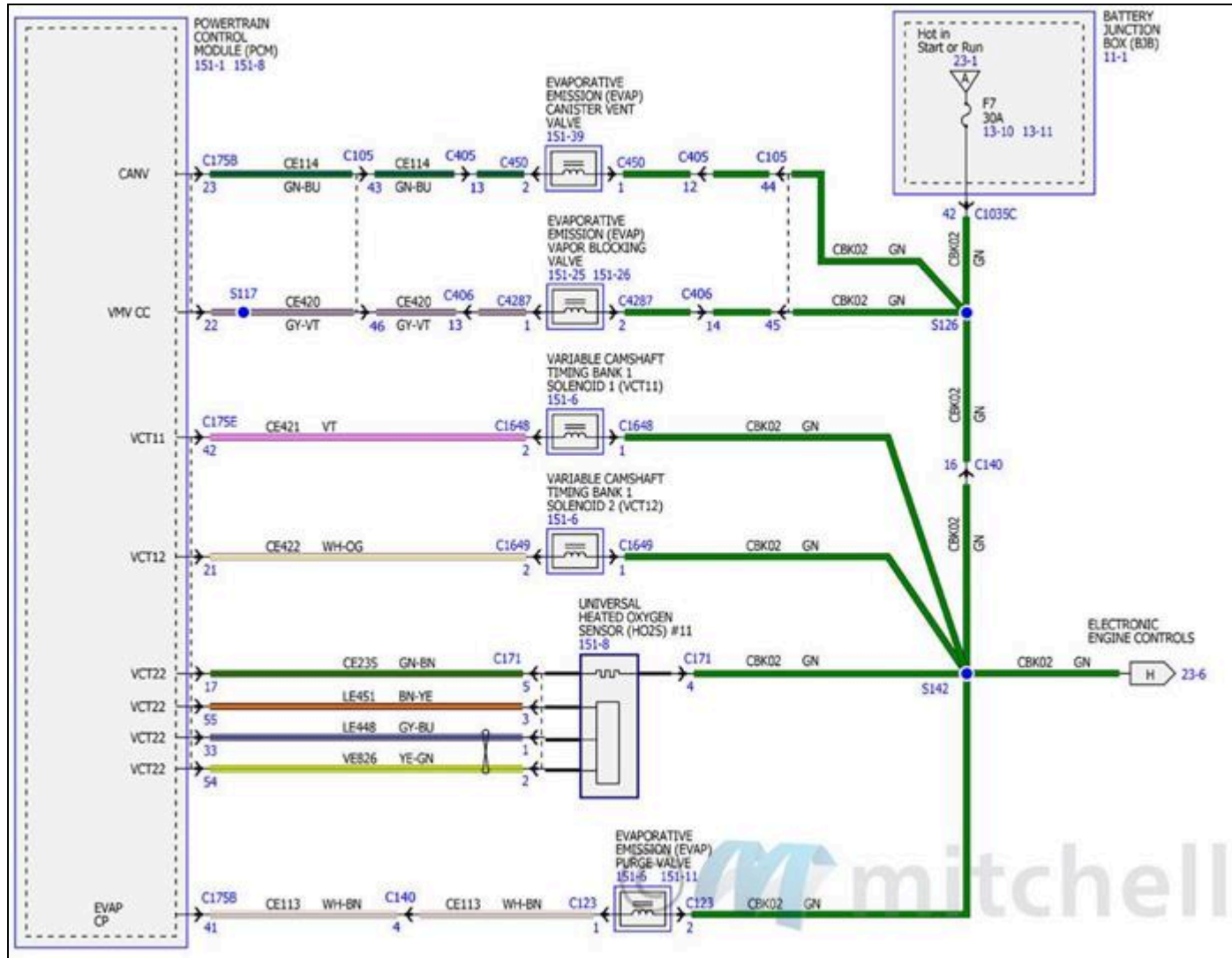

Fig. 50: Electronic Engine Controls Wiring Diagrams - 2.3L (8 Of 17)

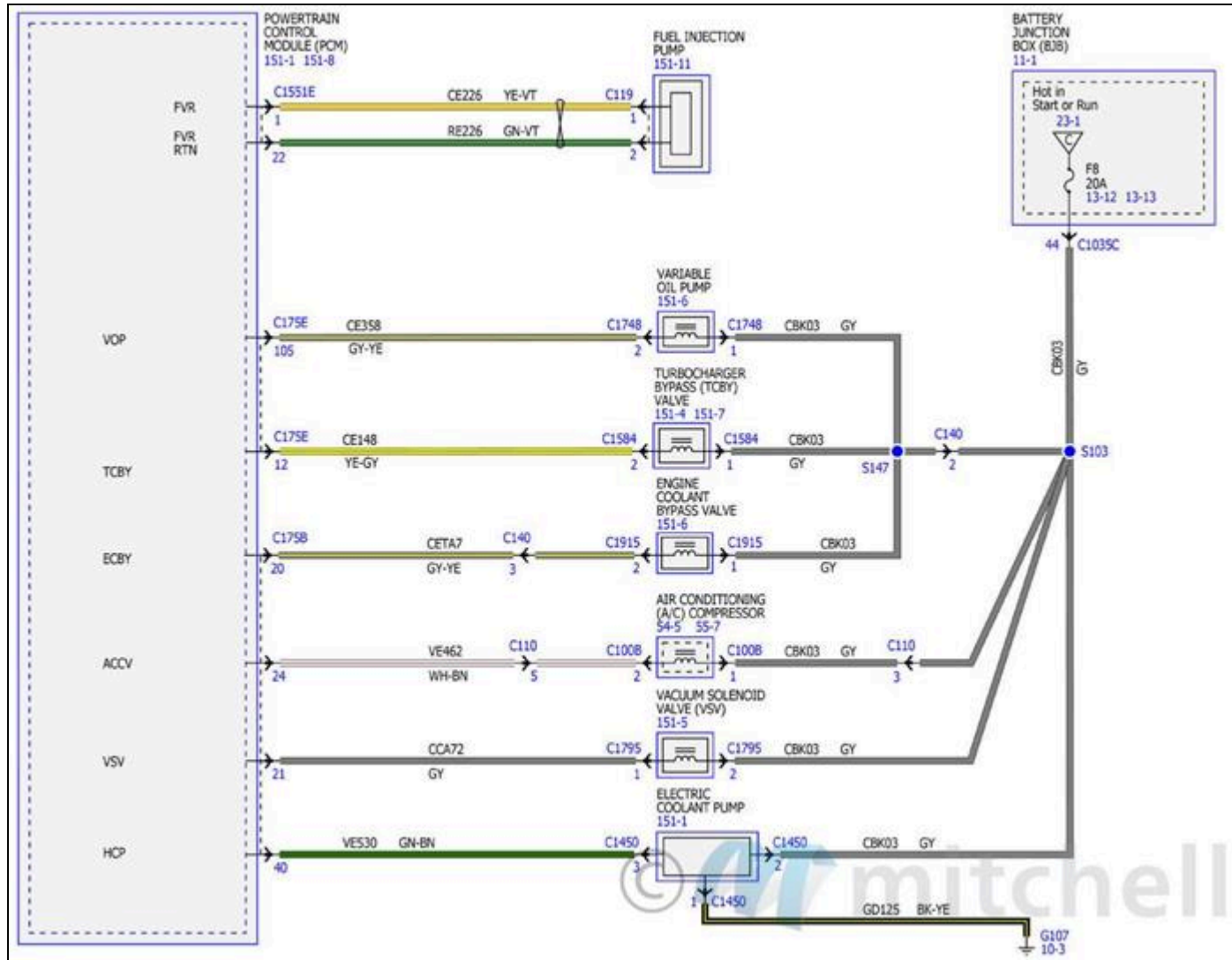

Fig. 51: Electronic Engine Controls Wiring Diagrams - 2.3L (9 Of 17)

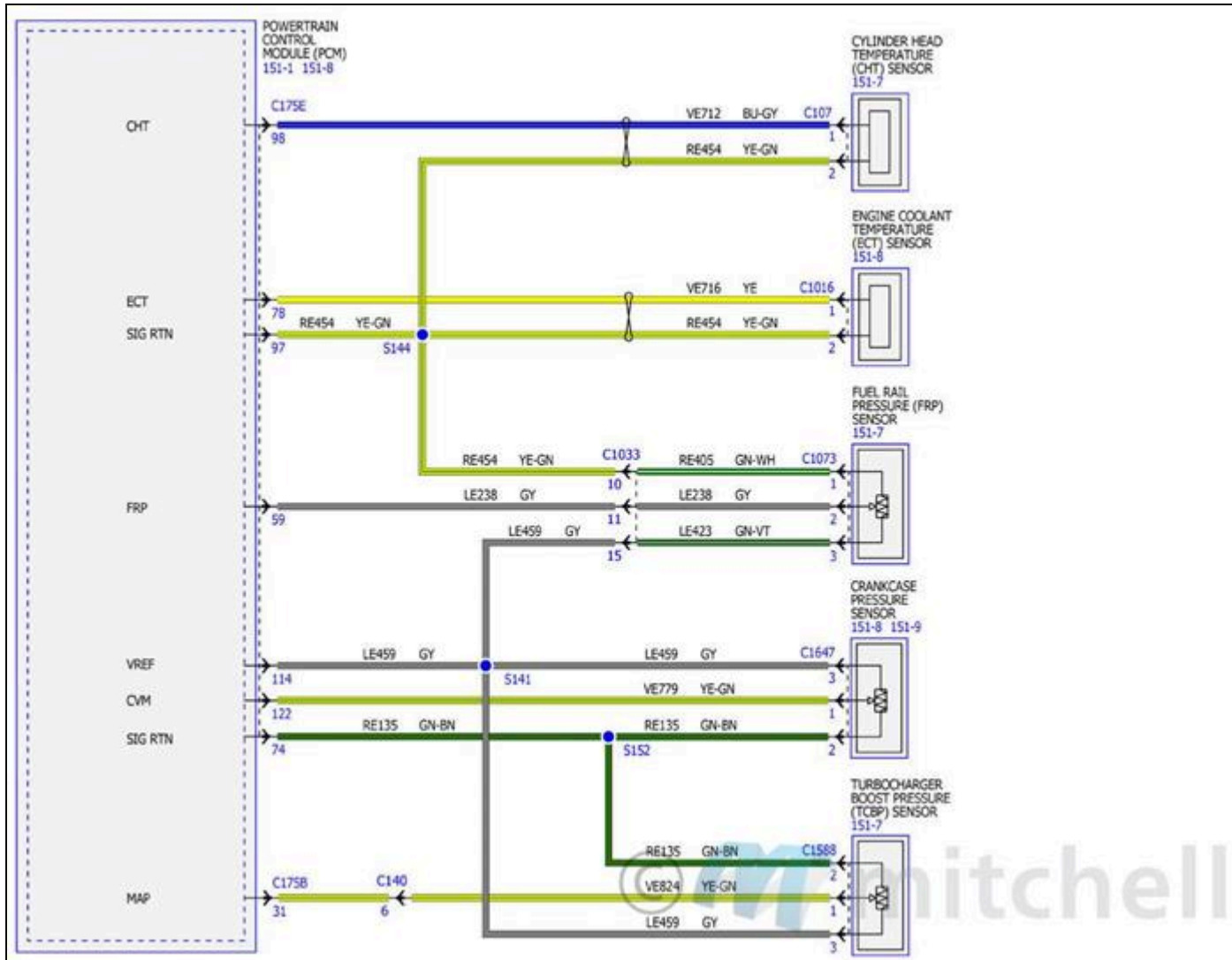

Fig. 52: Electronic Engine Controls Wiring Diagrams - 2.3L (10 Of 17)

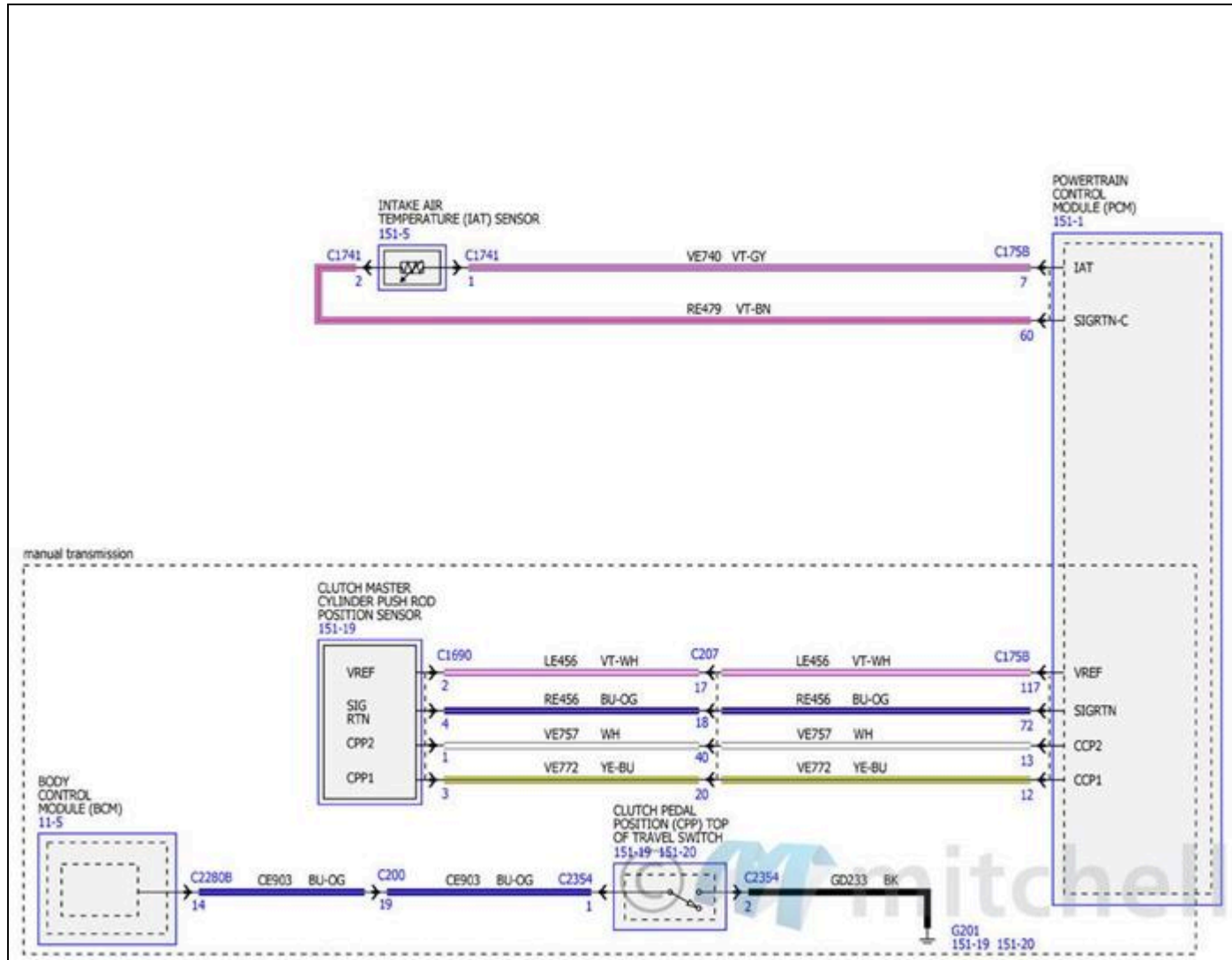

Fig. 53: Electronic Engine Controls Wiring Diagrams - 2.3L (11 Of 17)

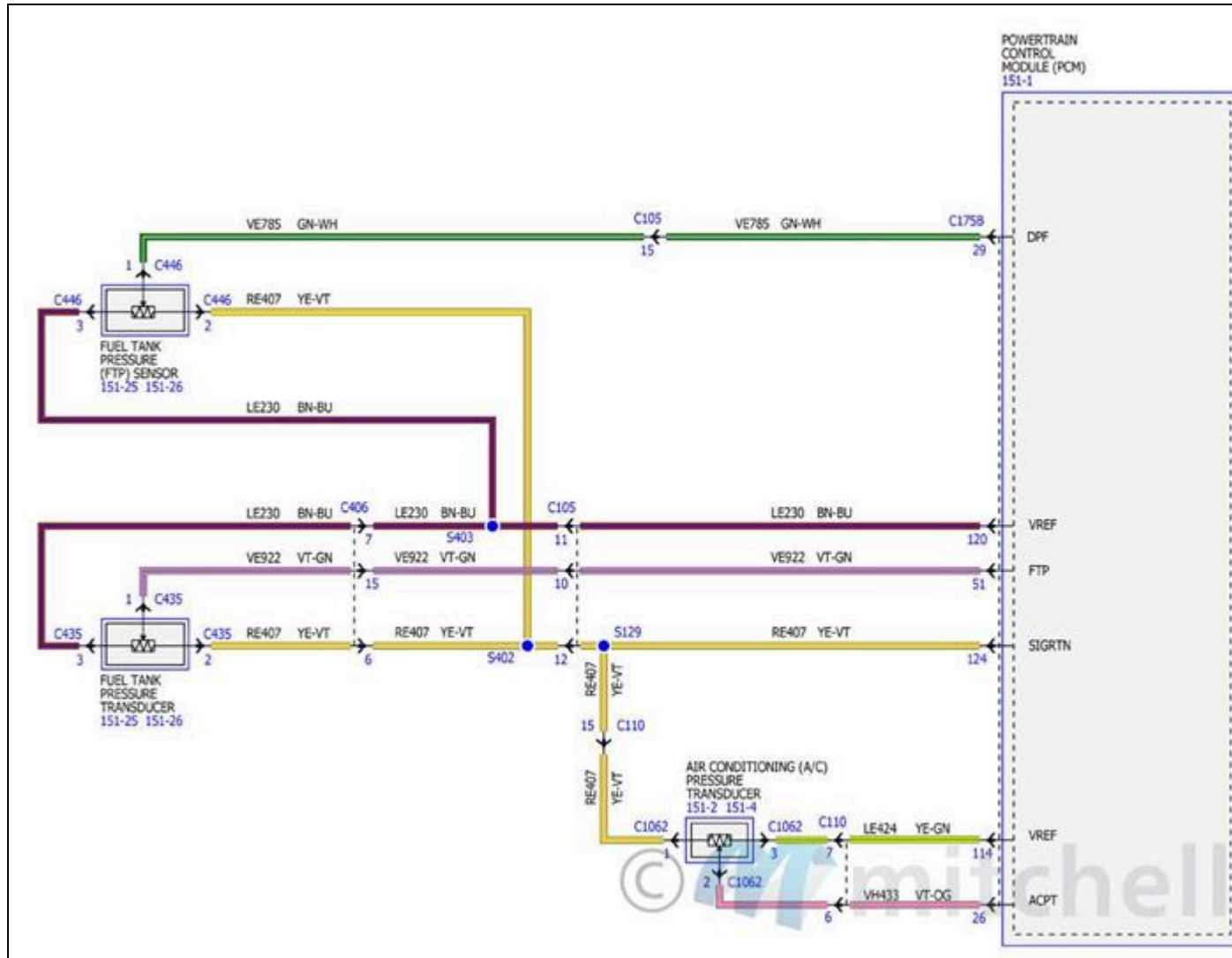

Fig. 54: Electronic Engine Controls Wiring Diagrams - 2.3L (12 Of 17)

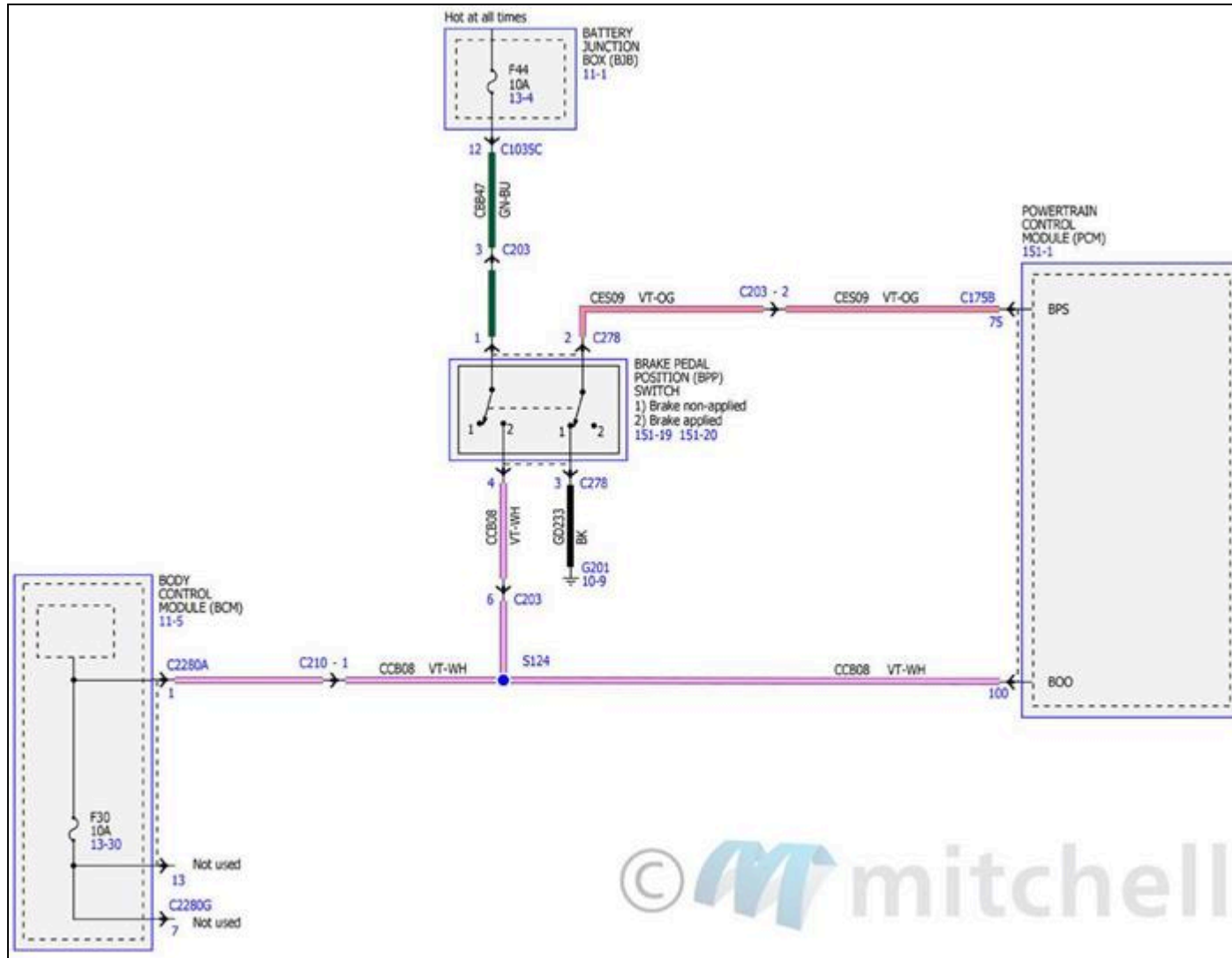

Fig. 55: Electronic Engine Controls Wiring Diagrams - 2.3L (13 Of 17)

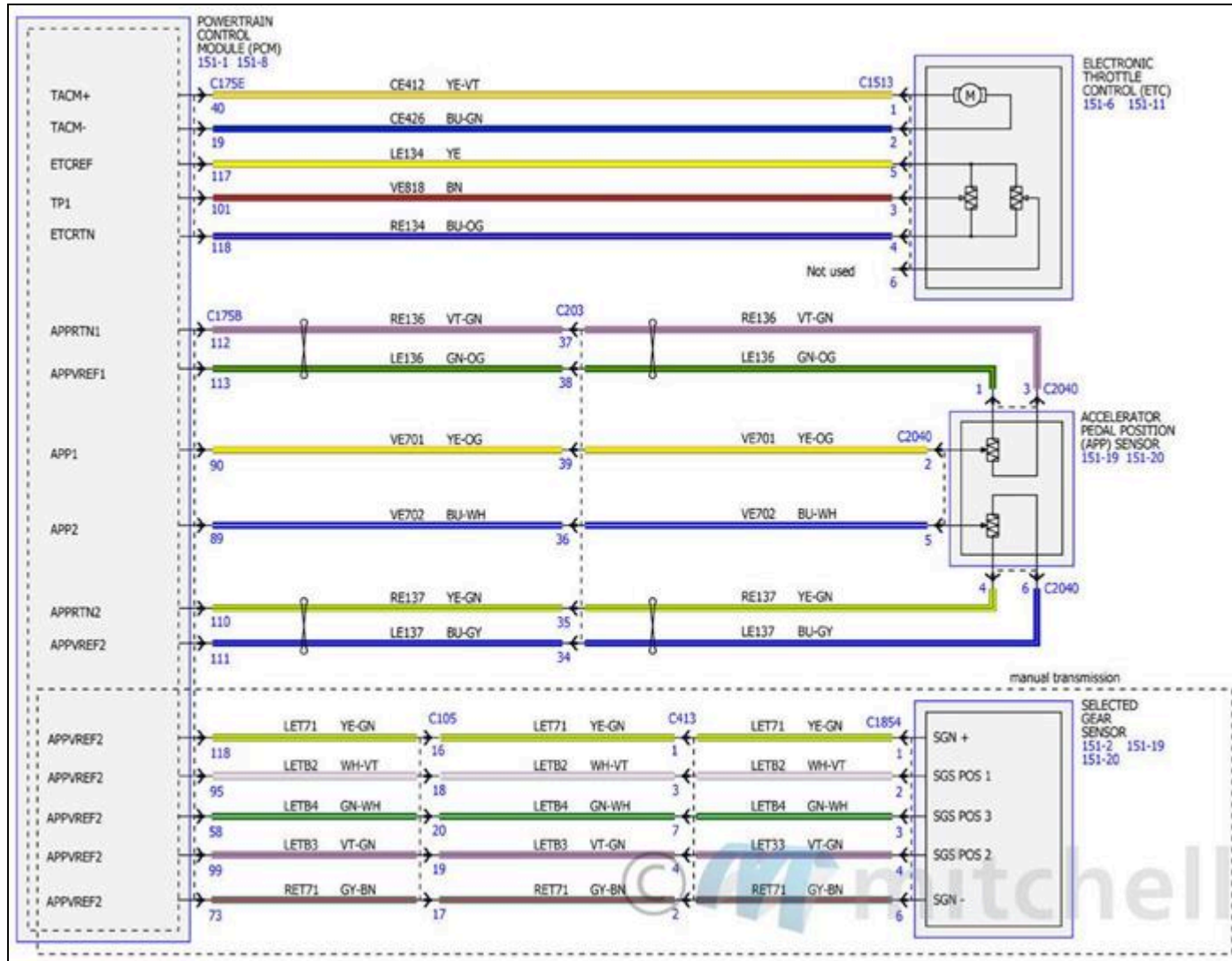

Fig. 56: Electronic Engine Controls Wiring Diagrams - 2.3L (14 Of 17)

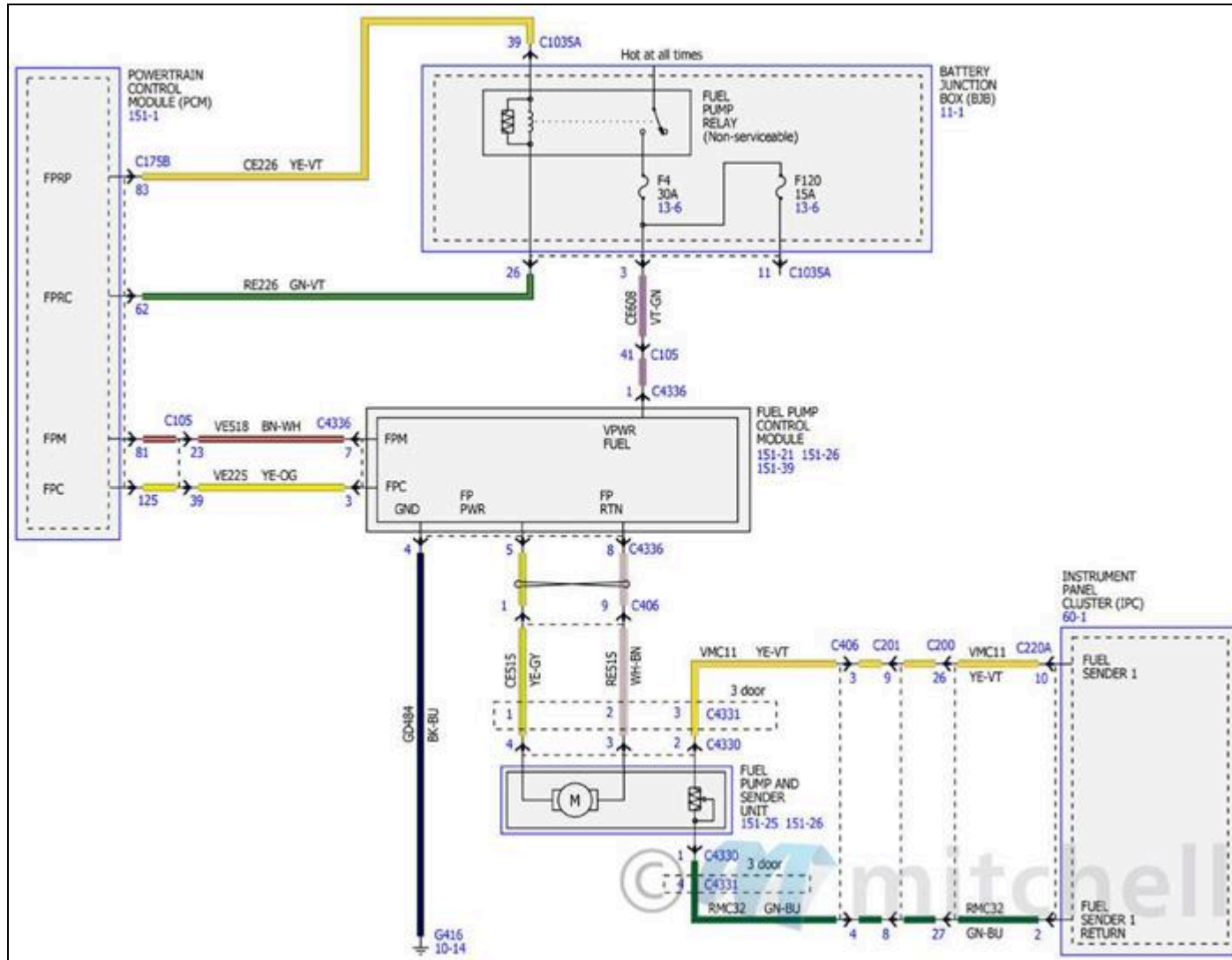

Fig. 57: Electronic Engine Controls Wiring Diagrams - 2.3L (15 Of 17)

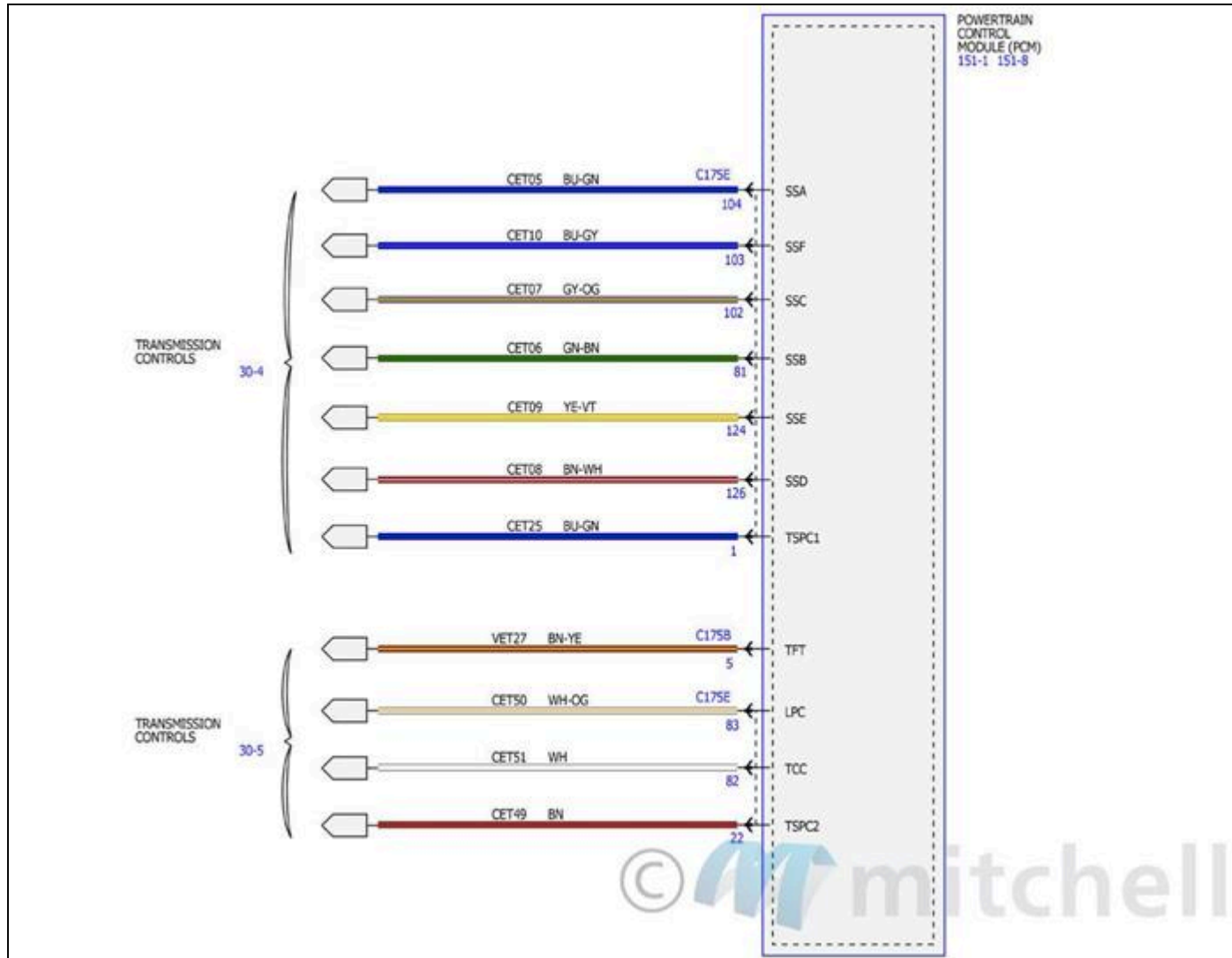

Fig. 58: Electronic Engine Controls Wiring Diagrams - 2.3L (16 Of 17)

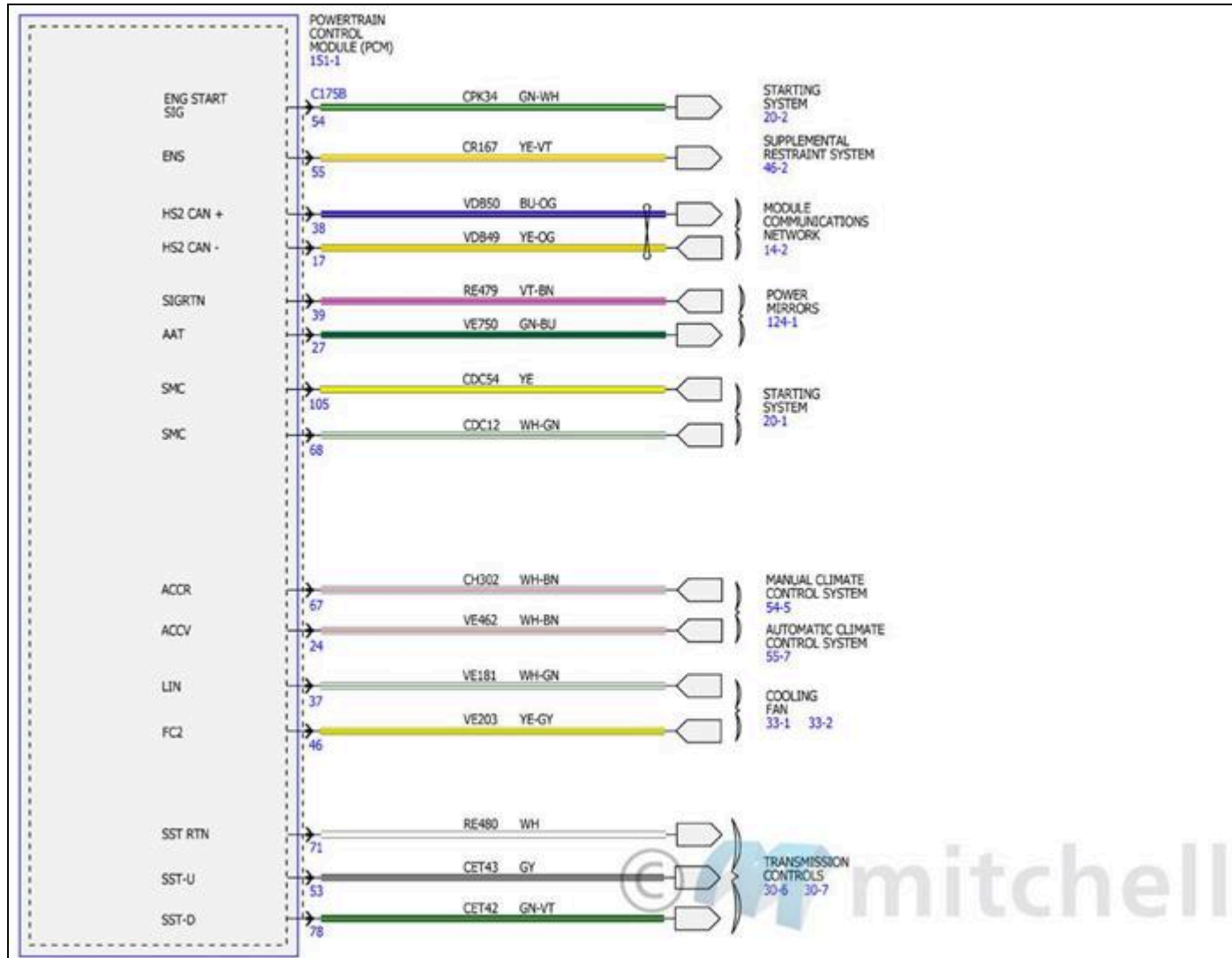
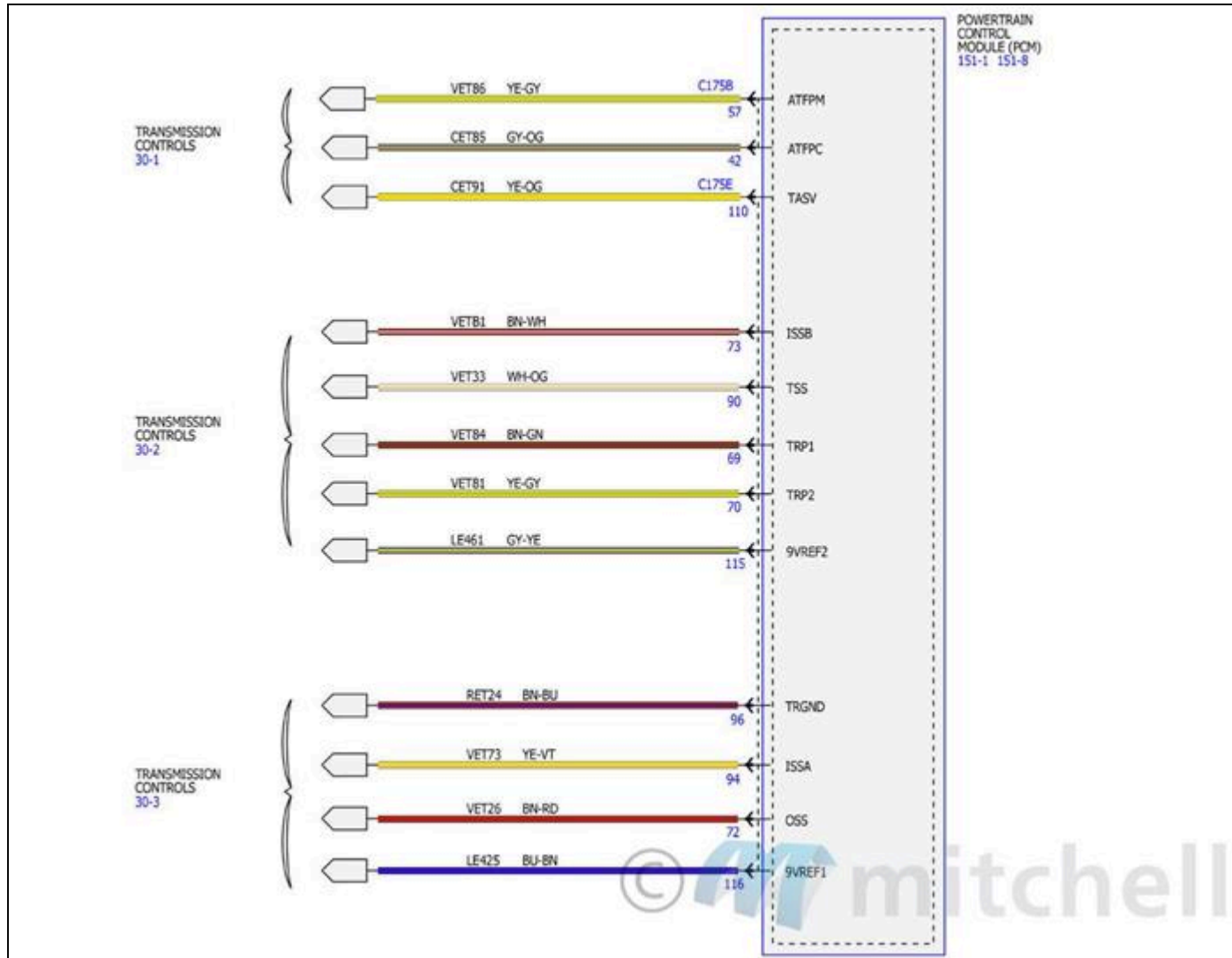

Fig. 59: Electronic Engine Controls Wiring Diagrams - 2.3L (17 Of 17)



ELECTRONIC ENGINE CONTROLS - 2.7L

Fig. 60: Electronic Engine Controls Wiring Diagrams - 2.7L (1 Of 18)

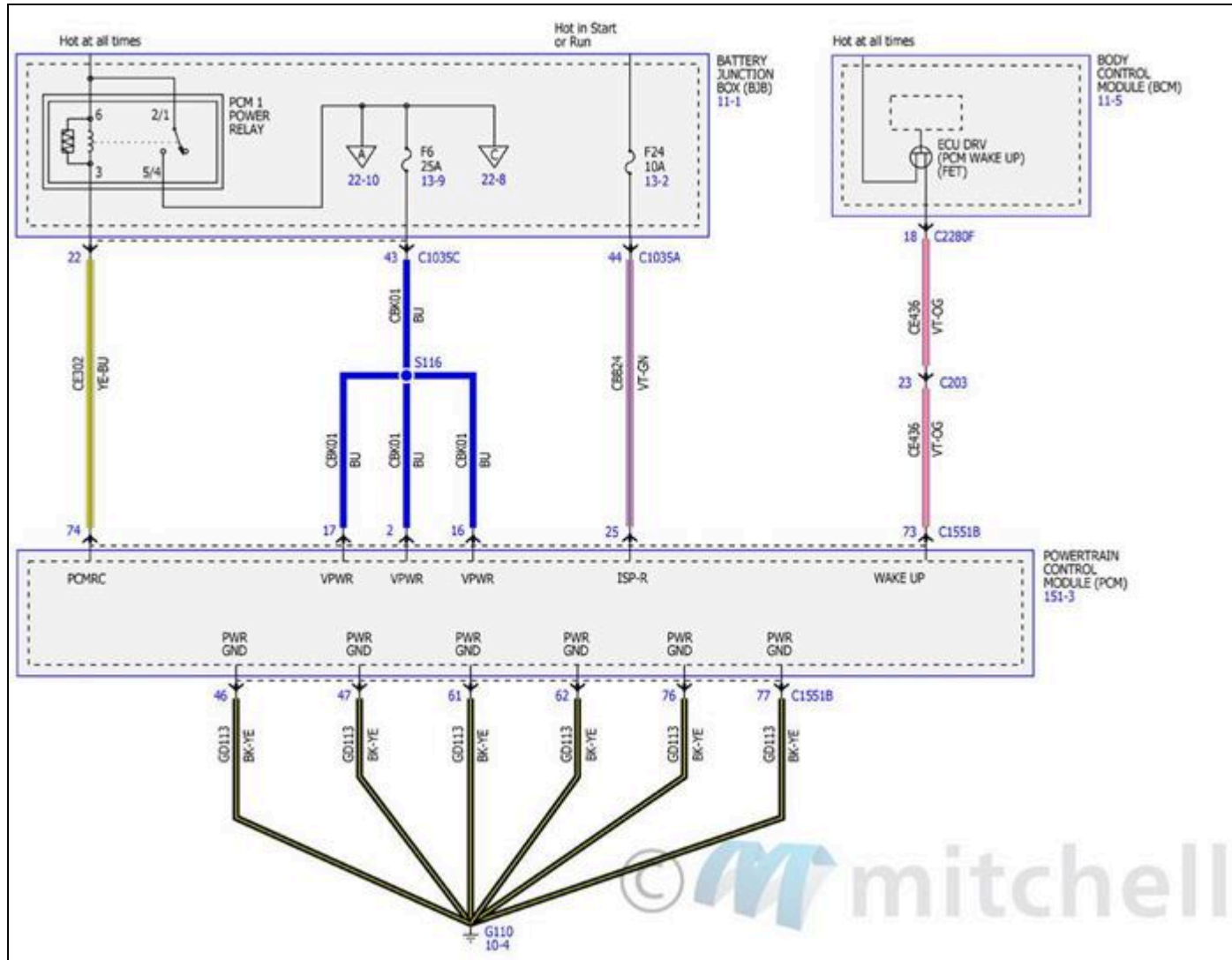

Fig. 61: Electronic Engine Controls Wiring Diagrams - 2.7L (2 Of 18)

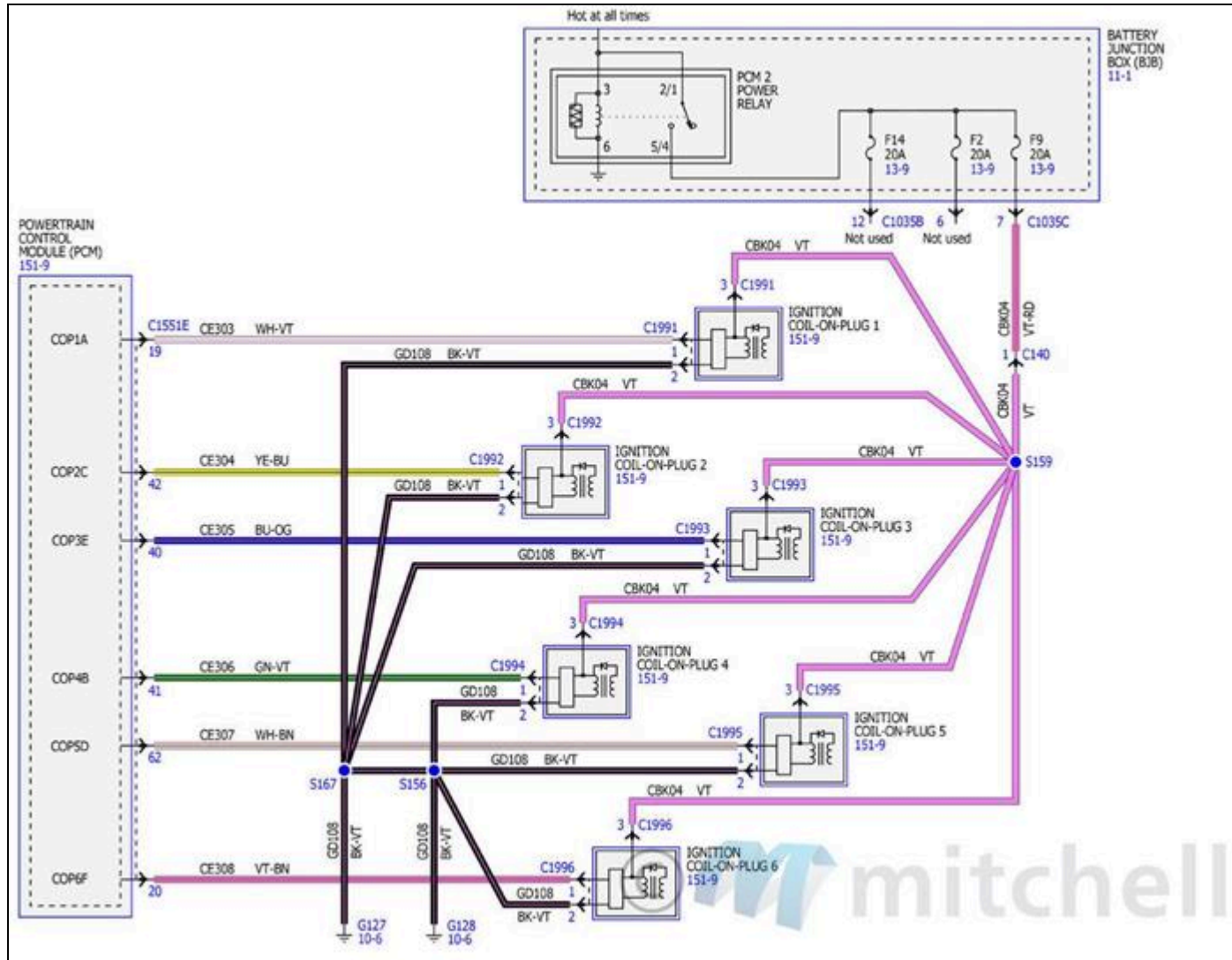

Fig. 62: Electronic Engine Controls Wiring Diagrams - 2.7L (3 Of 18)

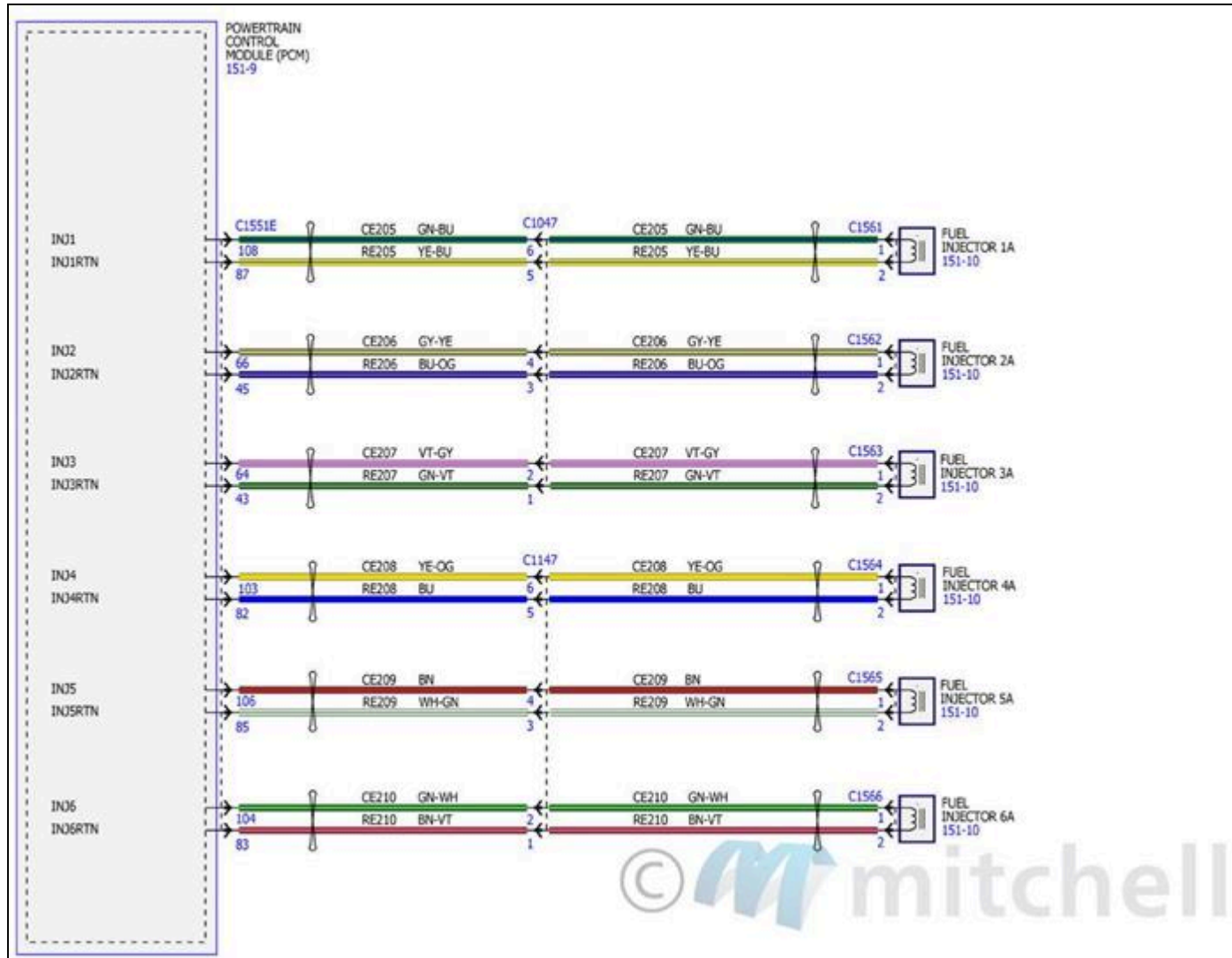

Fig. 63: Electronic Engine Controls Wiring Diagrams - 2.7L (4 Of 18)

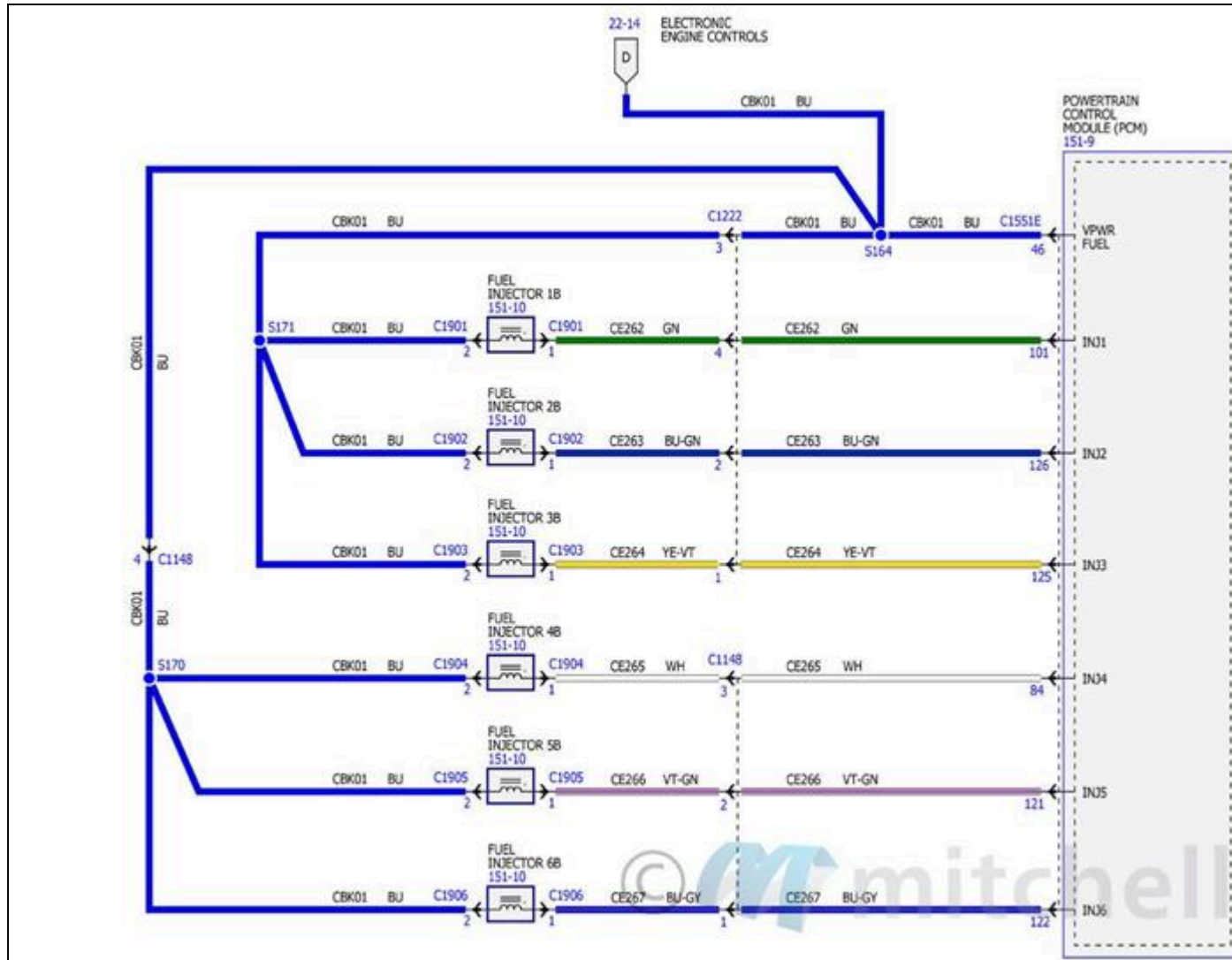

Fig. 64: Electronic Engine Controls Wiring Diagrams - 2.7L (5 Of 18)

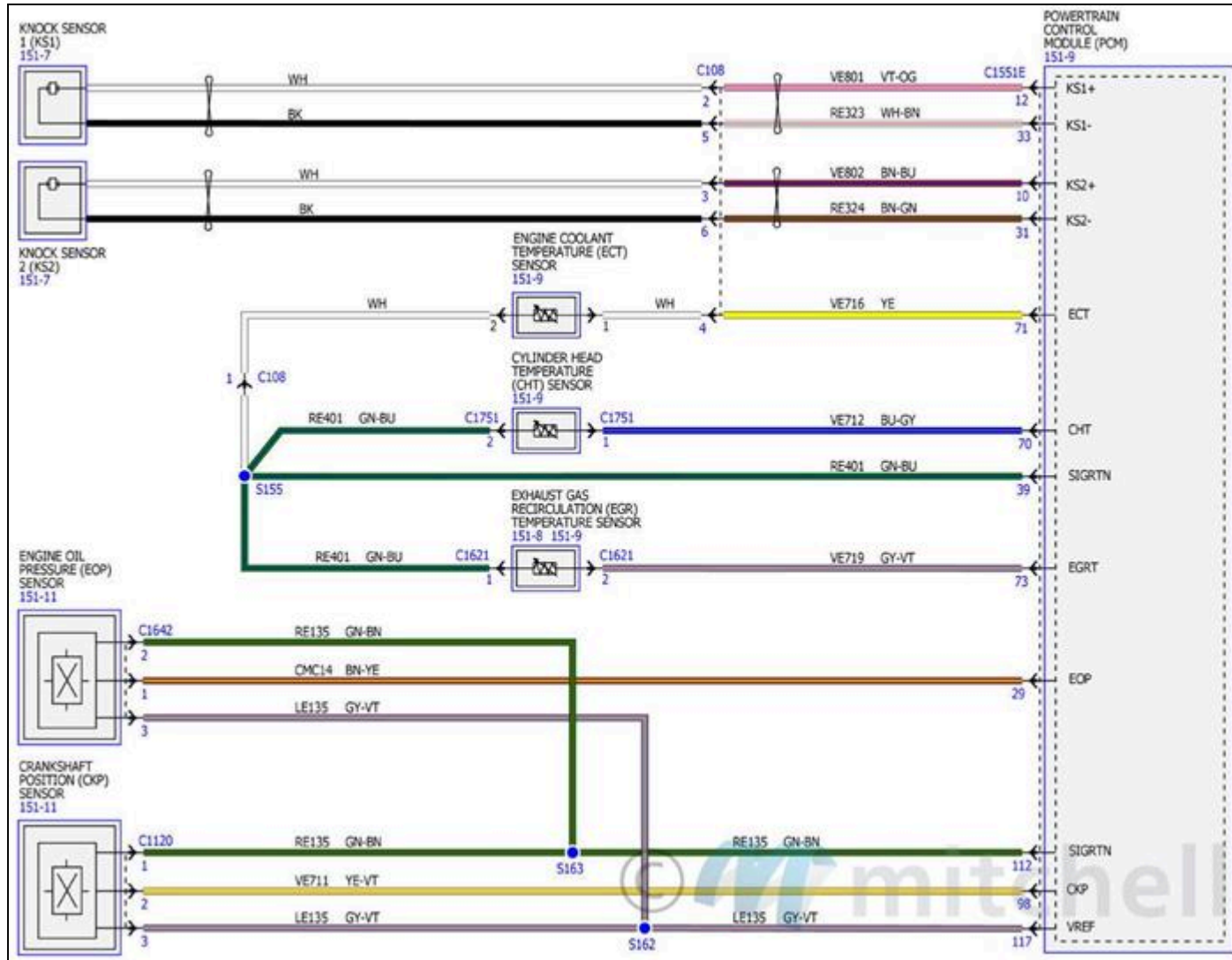

Fig. 65: Electronic Engine Controls Wiring Diagrams - 2.7L (6 Of 18)

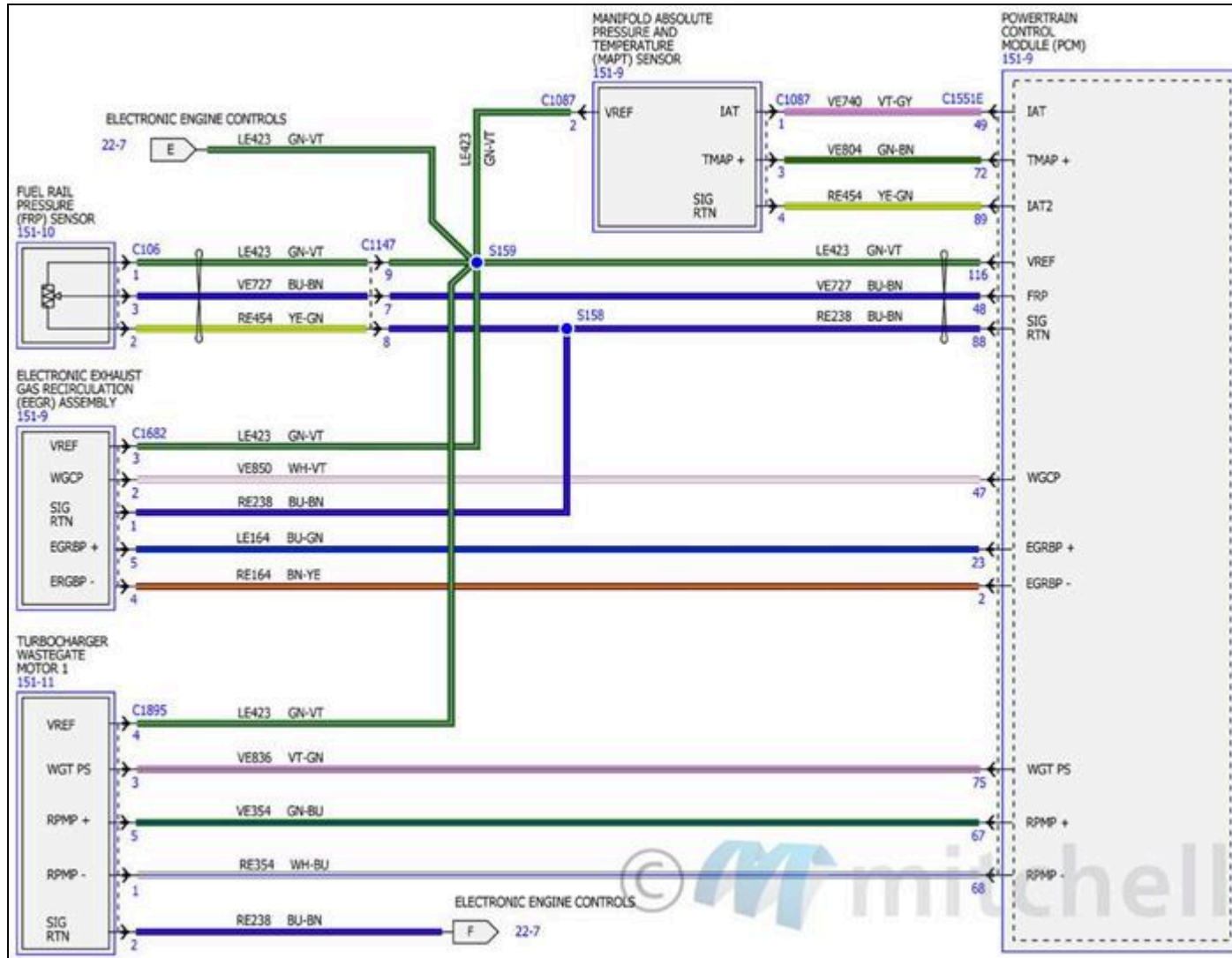

Fig. 66: Electronic Engine Controls Wiring Diagrams - 2.7L (7 Of 18)

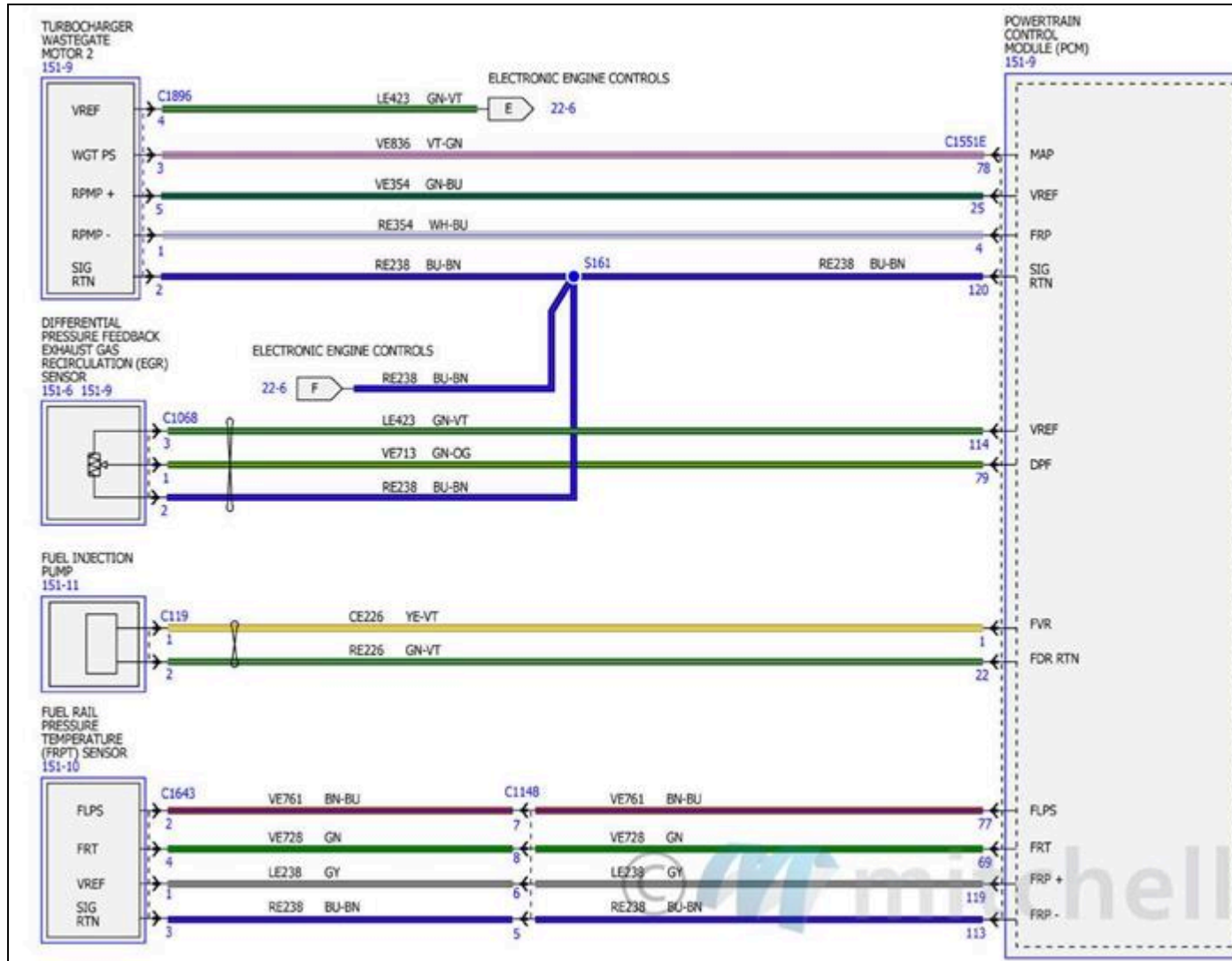

Fig. 67: Electronic Engine Controls Wiring Diagrams - 2.7L (8 Of 18)

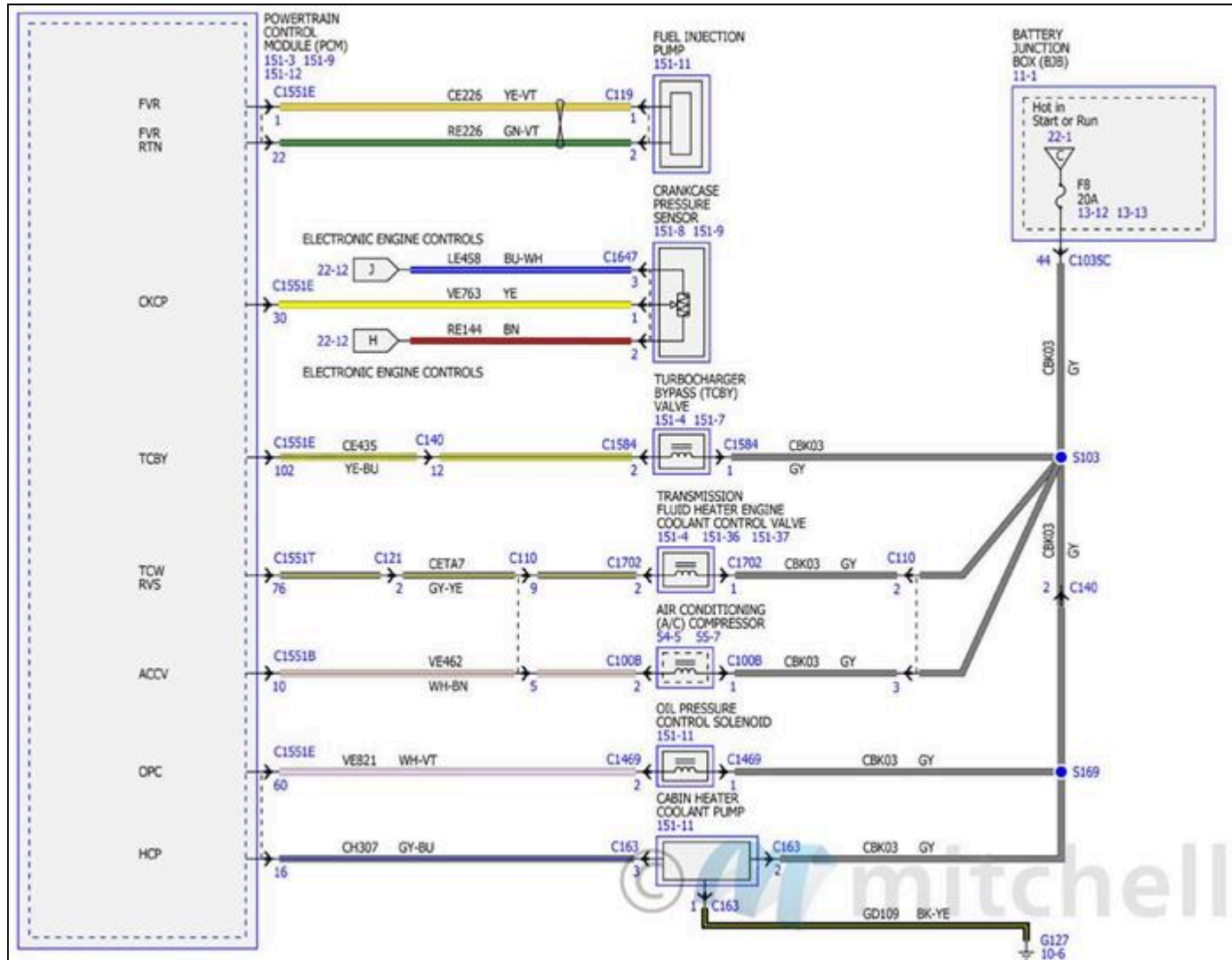

Fig. 68: Electronic Engine Controls Wiring Diagrams - 2.7L (9 Of 18)

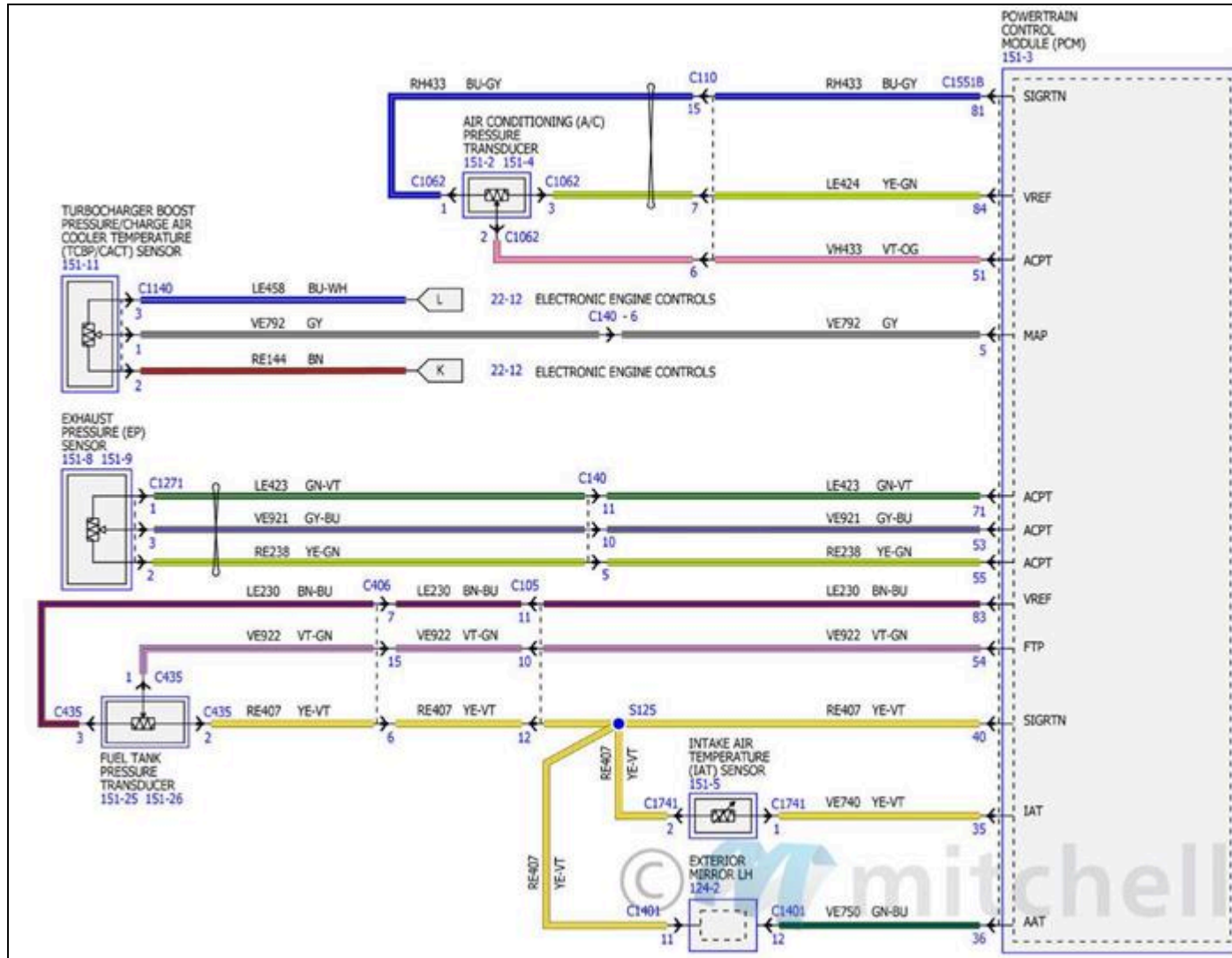

Fig. 69: Electronic Engine Controls Wiring Diagrams - 2.7L (10 Of 18)

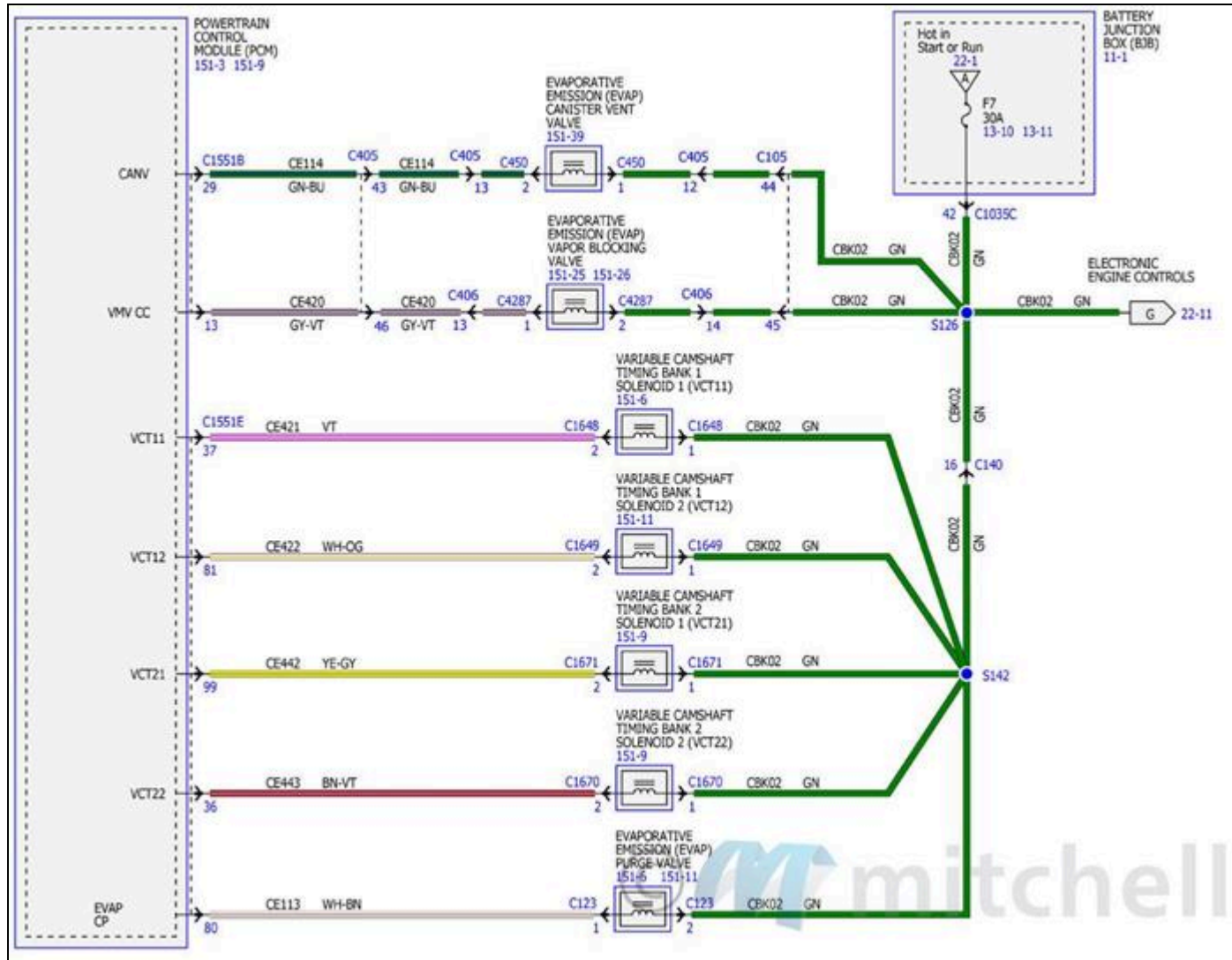

Fig. 70: Electronic Engine Controls Wiring Diagrams - 2.7L (11 Of 18)

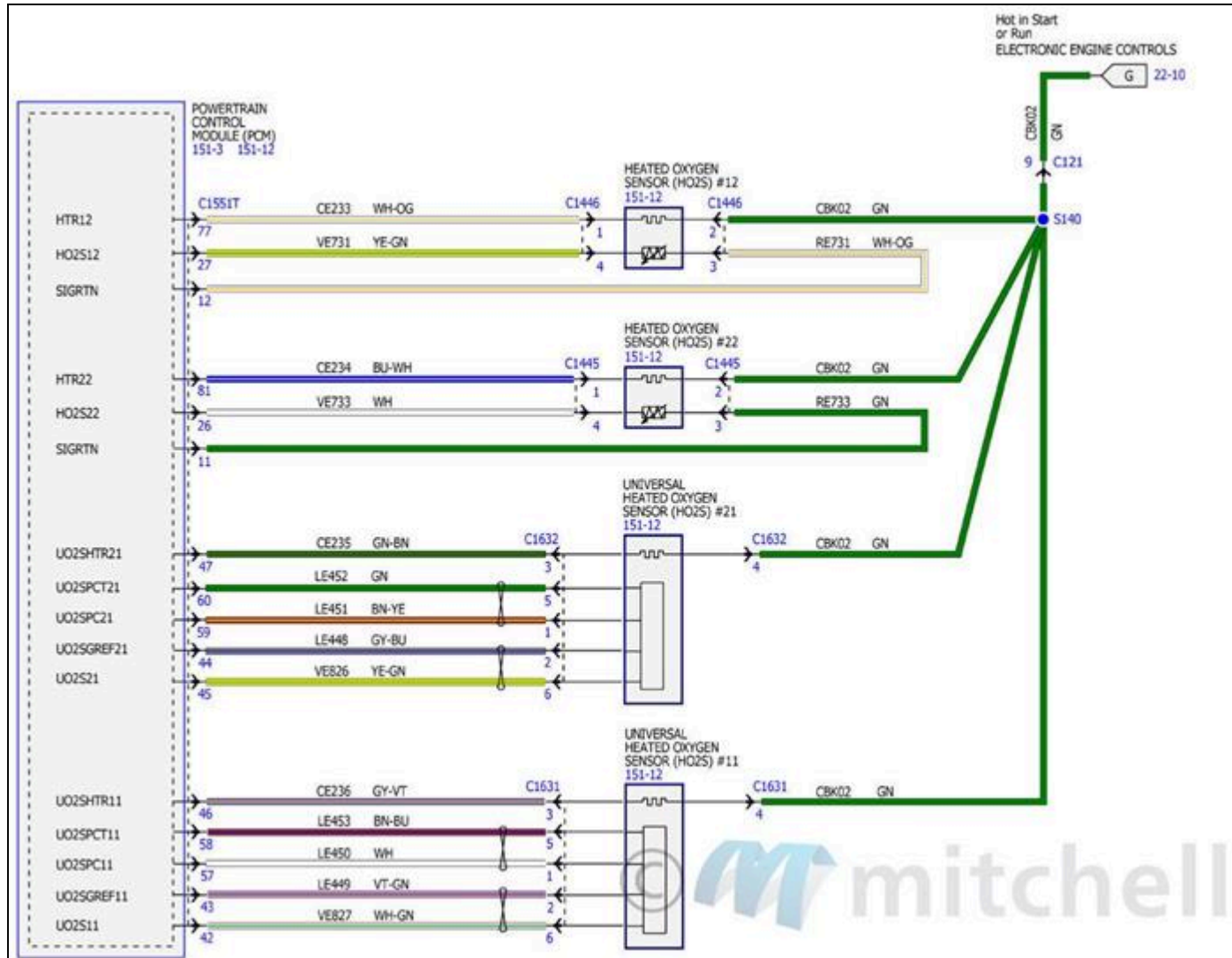

Fig. 71: Electronic Engine Controls Wiring Diagrams - 2.7L (12 Of 18)

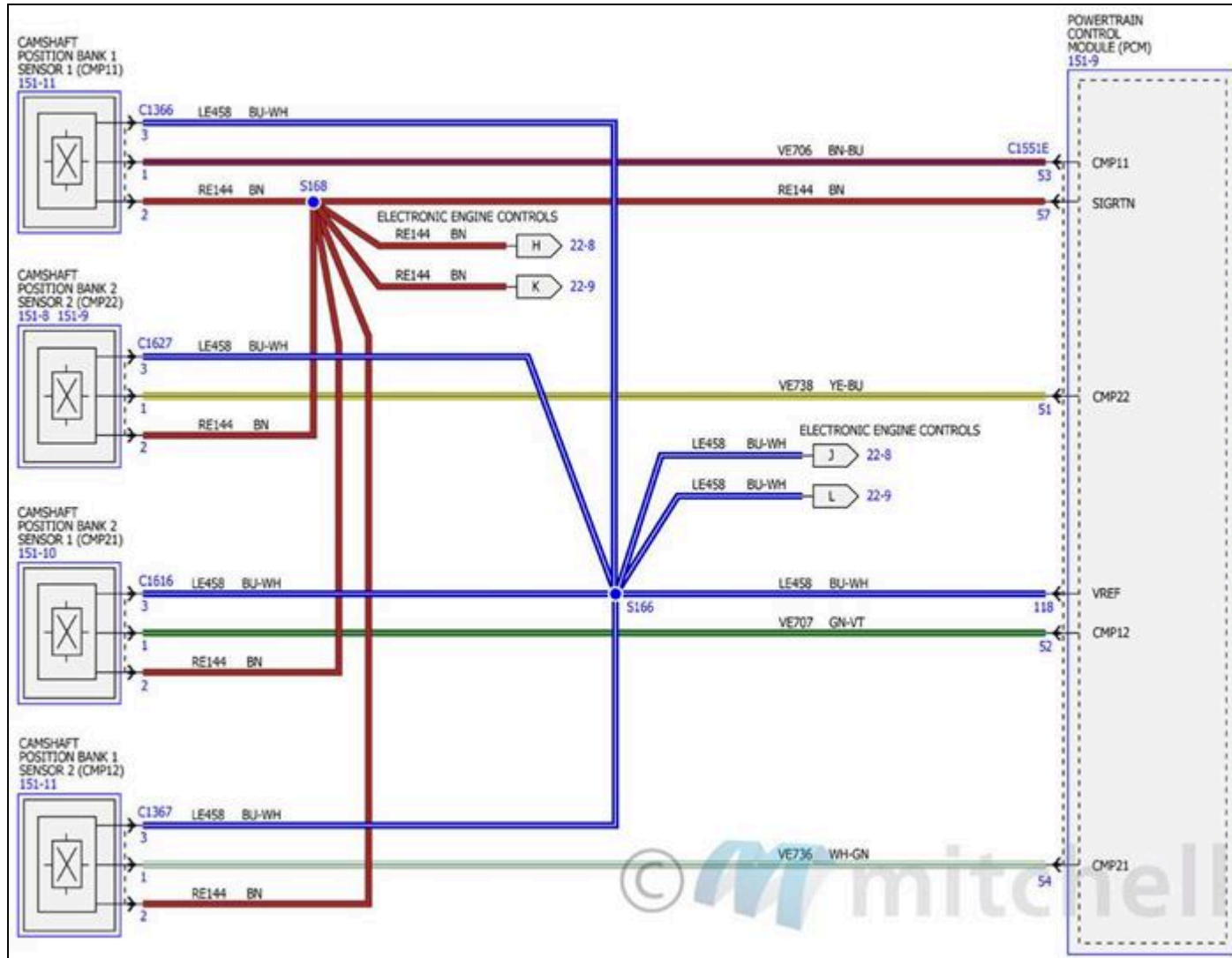

Fig. 72: Electronic Engine Controls Wiring Diagrams - 2.7L (13 Of 18)

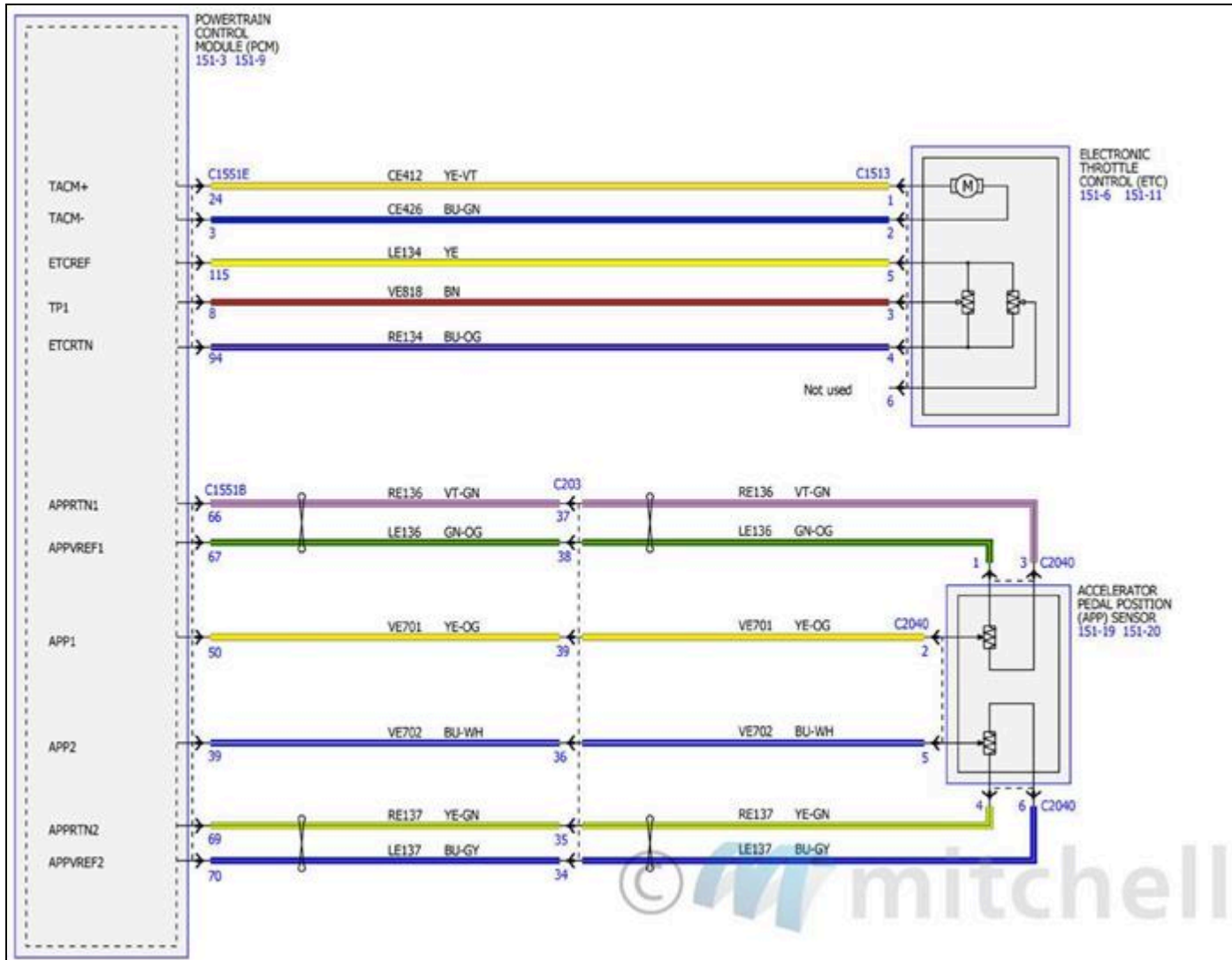

Fig. 73: Electronic Engine Controls Wiring Diagrams - 2.7L (14 Of 18)

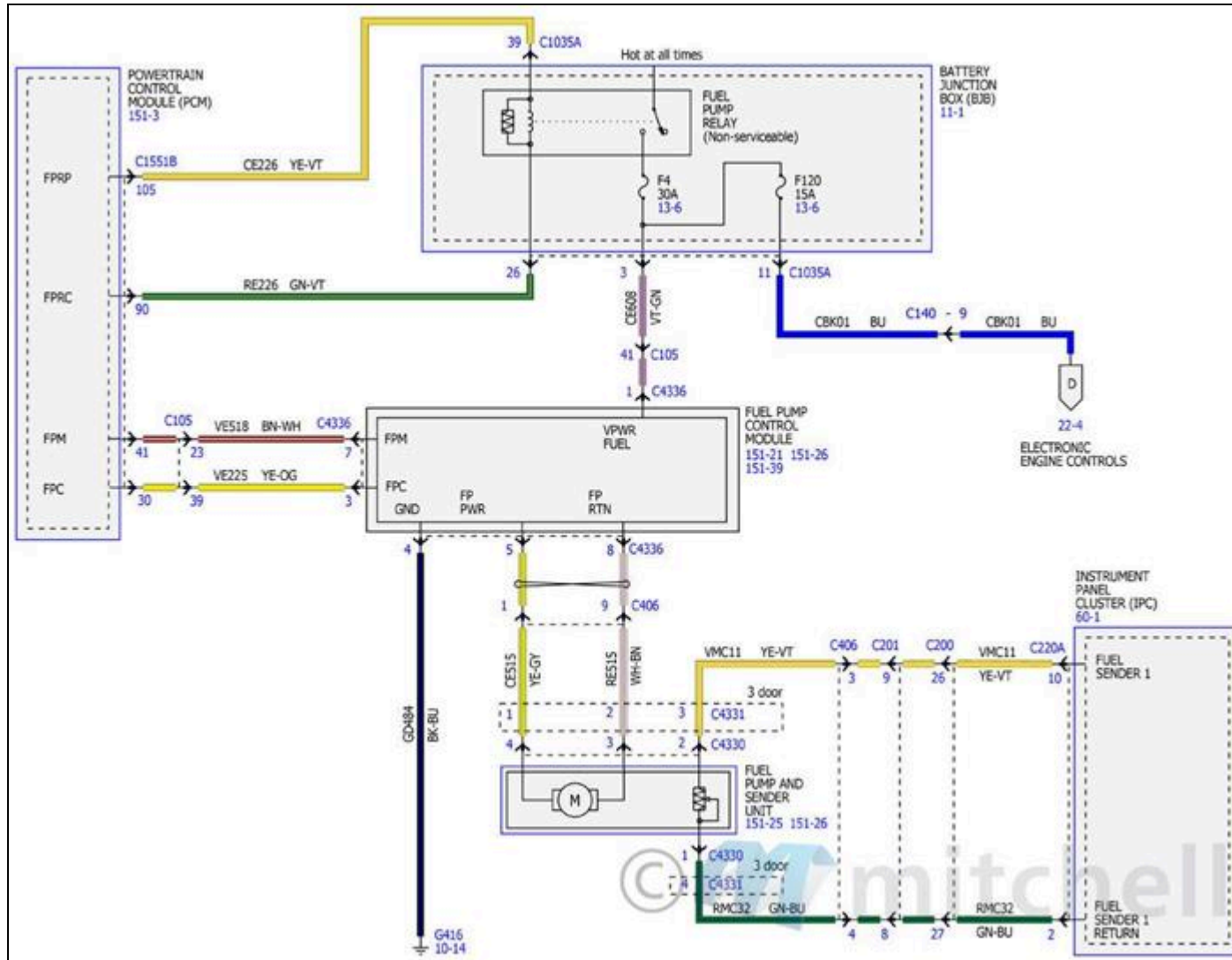

Fig. 74: Electronic Engine Controls Wiring Diagrams - 2.7L (15 Of 18)

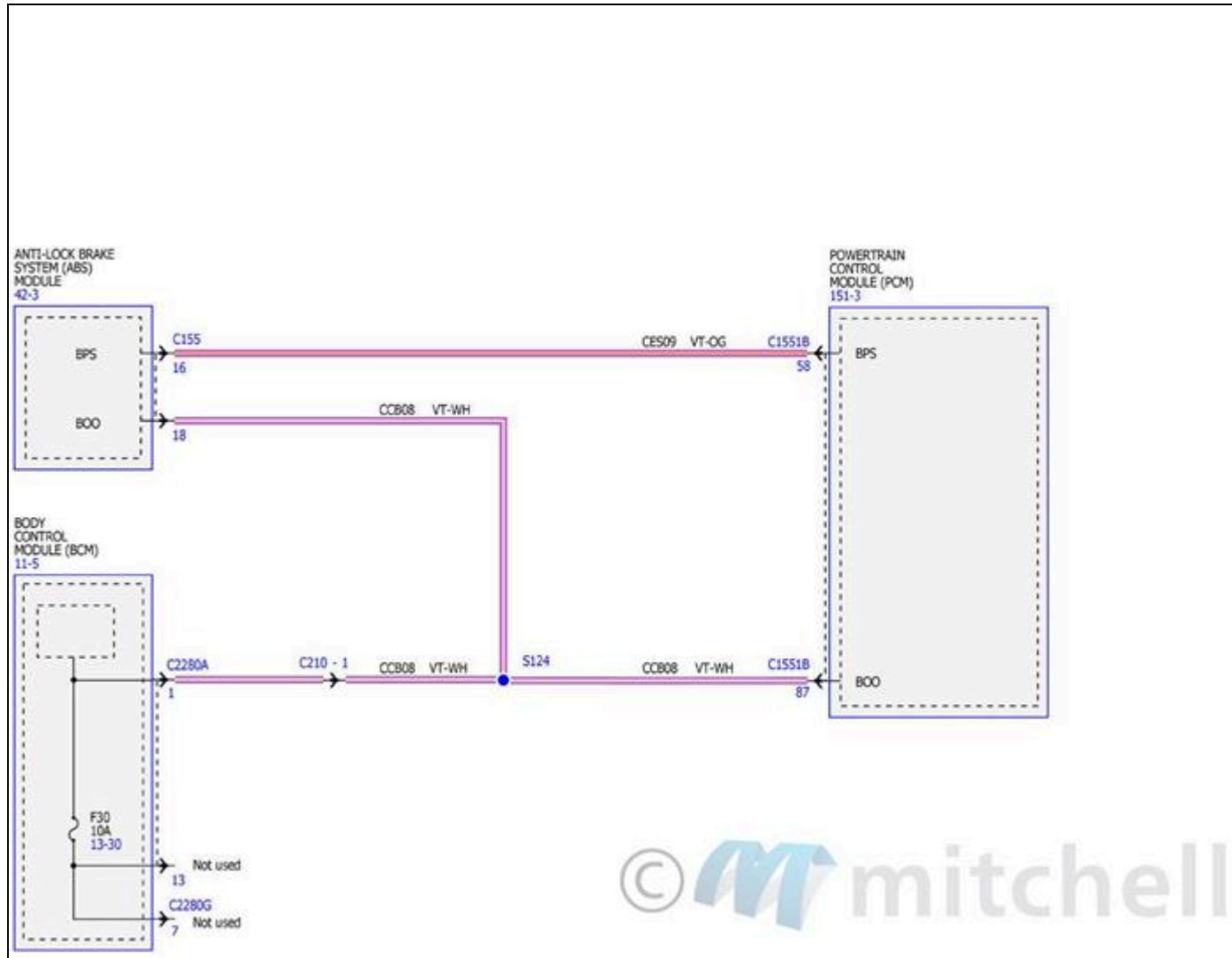

Fig. 75: Electronic Engine Controls Wiring Diagrams - 2.7L (16 Of 18)

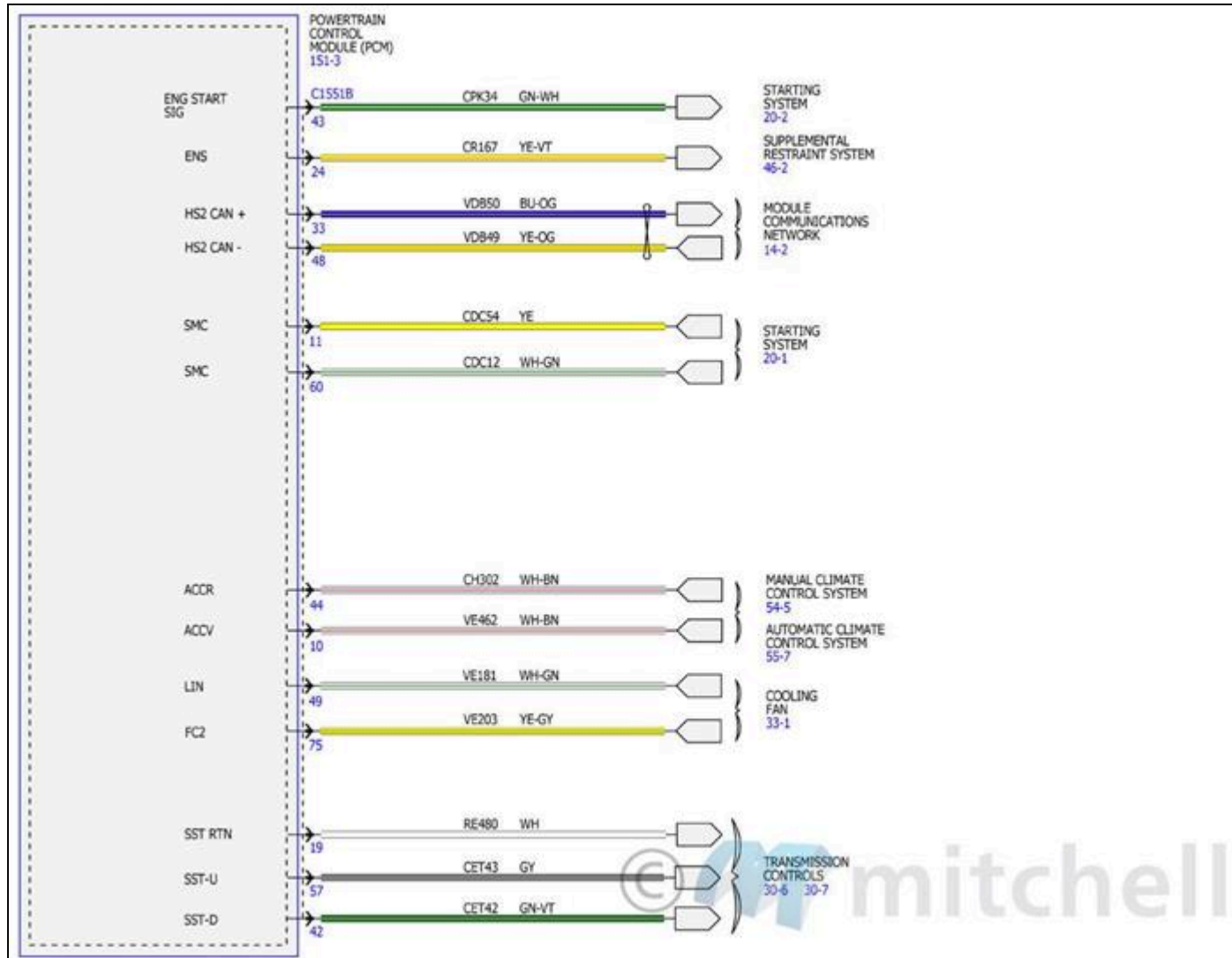

Fig. 76: Electronic Engine Controls Wiring Diagrams - 2.7L (17 Of 18)

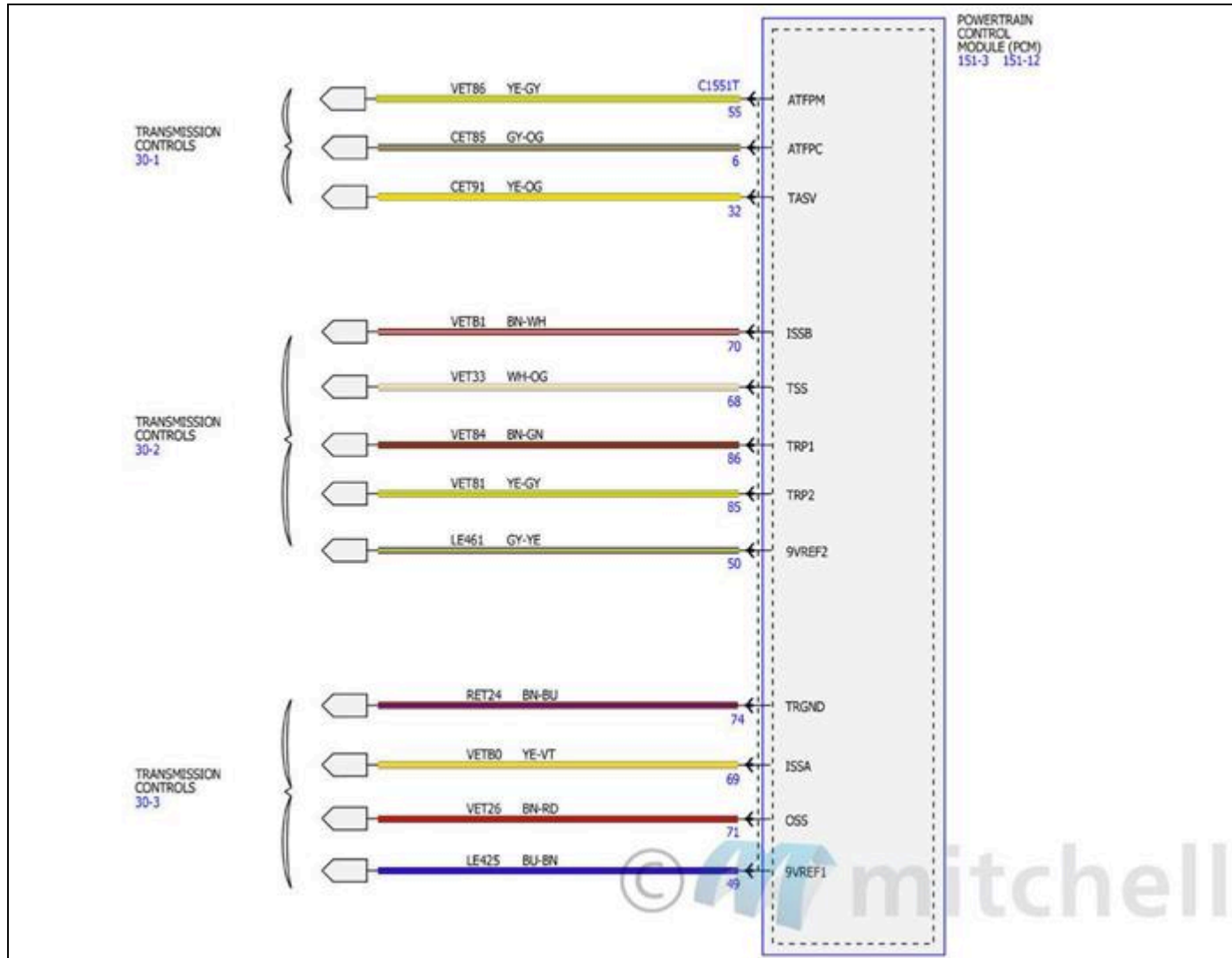
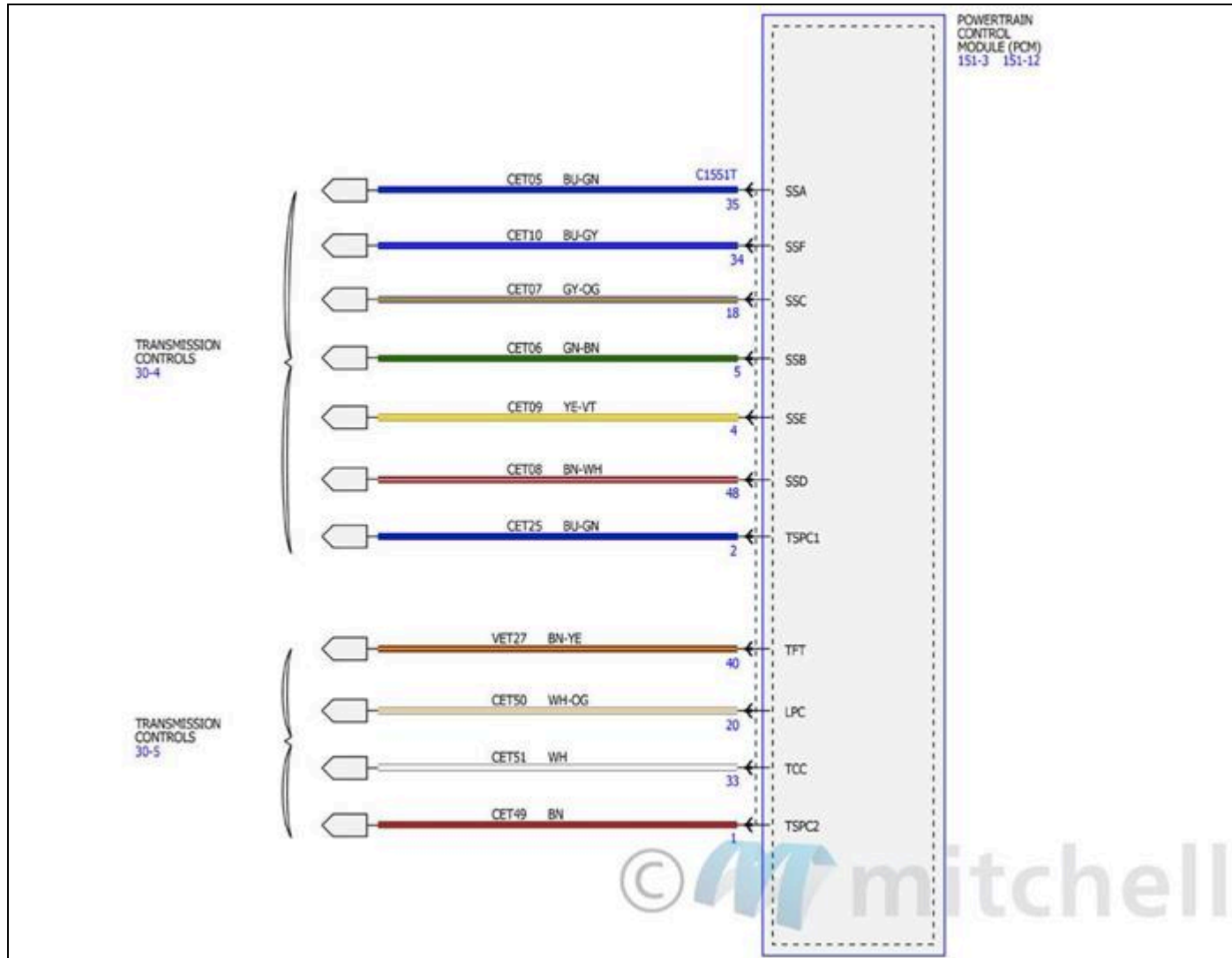

Fig. 77: Electronic Engine Controls Wiring Diagrams - 2.7L (18 Of 18)



FOG LAMPS

Fig. 78: Fog Lamps Wiring Diagrams (1 Of 2)

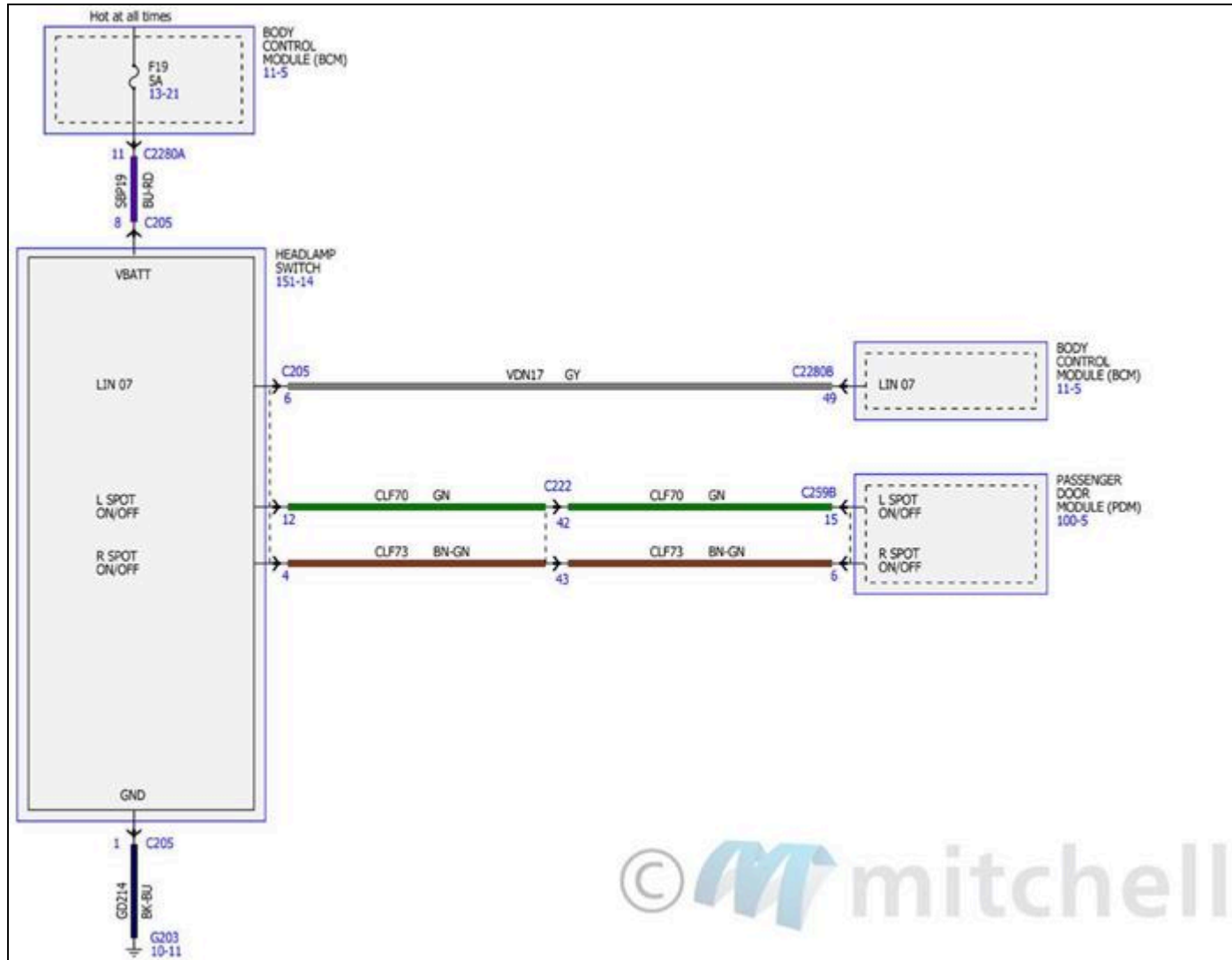
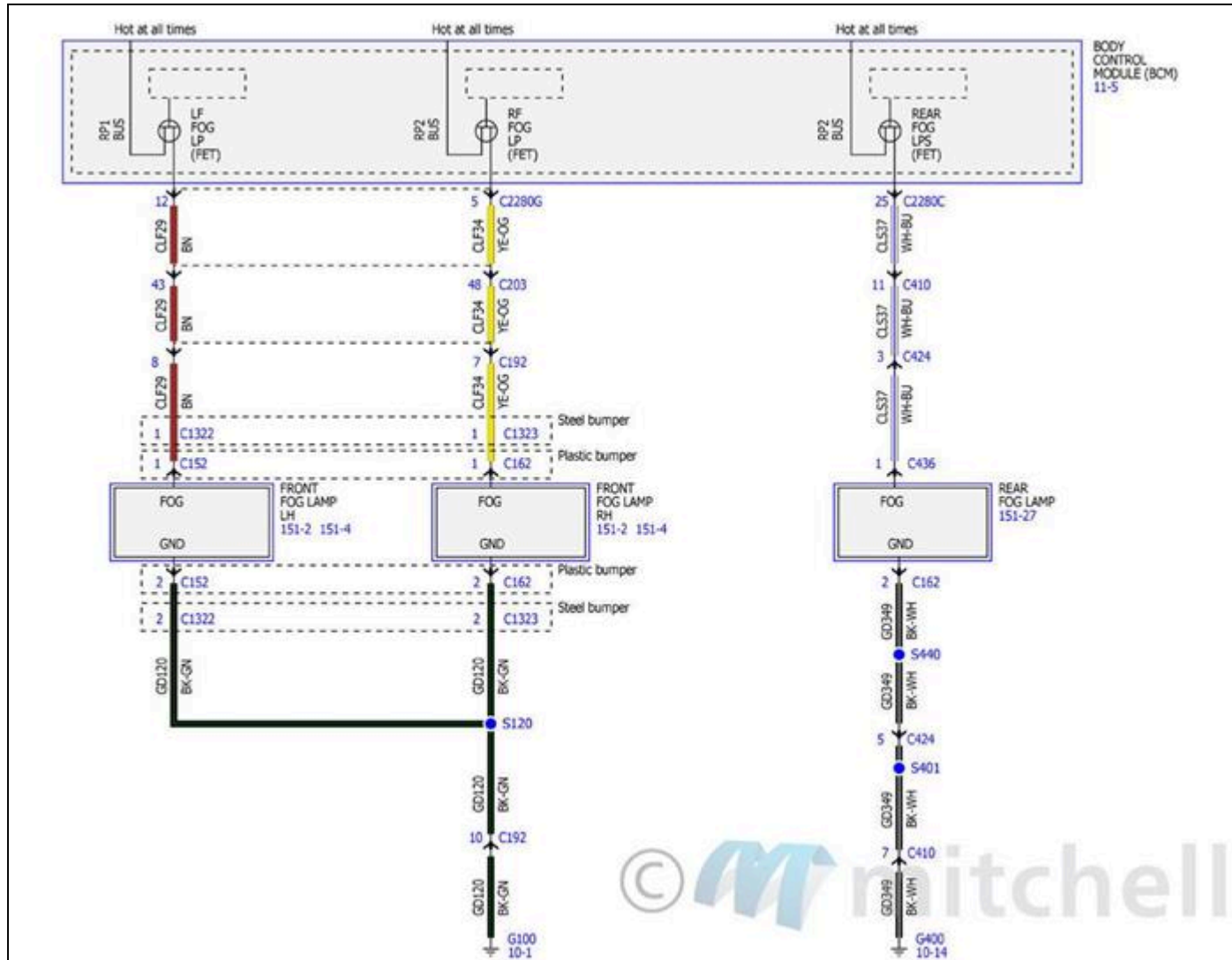

Fig. 79: Fog Lamps Wiring Diagrams (2 Of 2)



FOUR WHEEL DRIVE SYSTEMS

Fig. 80: Four Wheel Drive Systems Wiring Diagrams (1 Of 4)

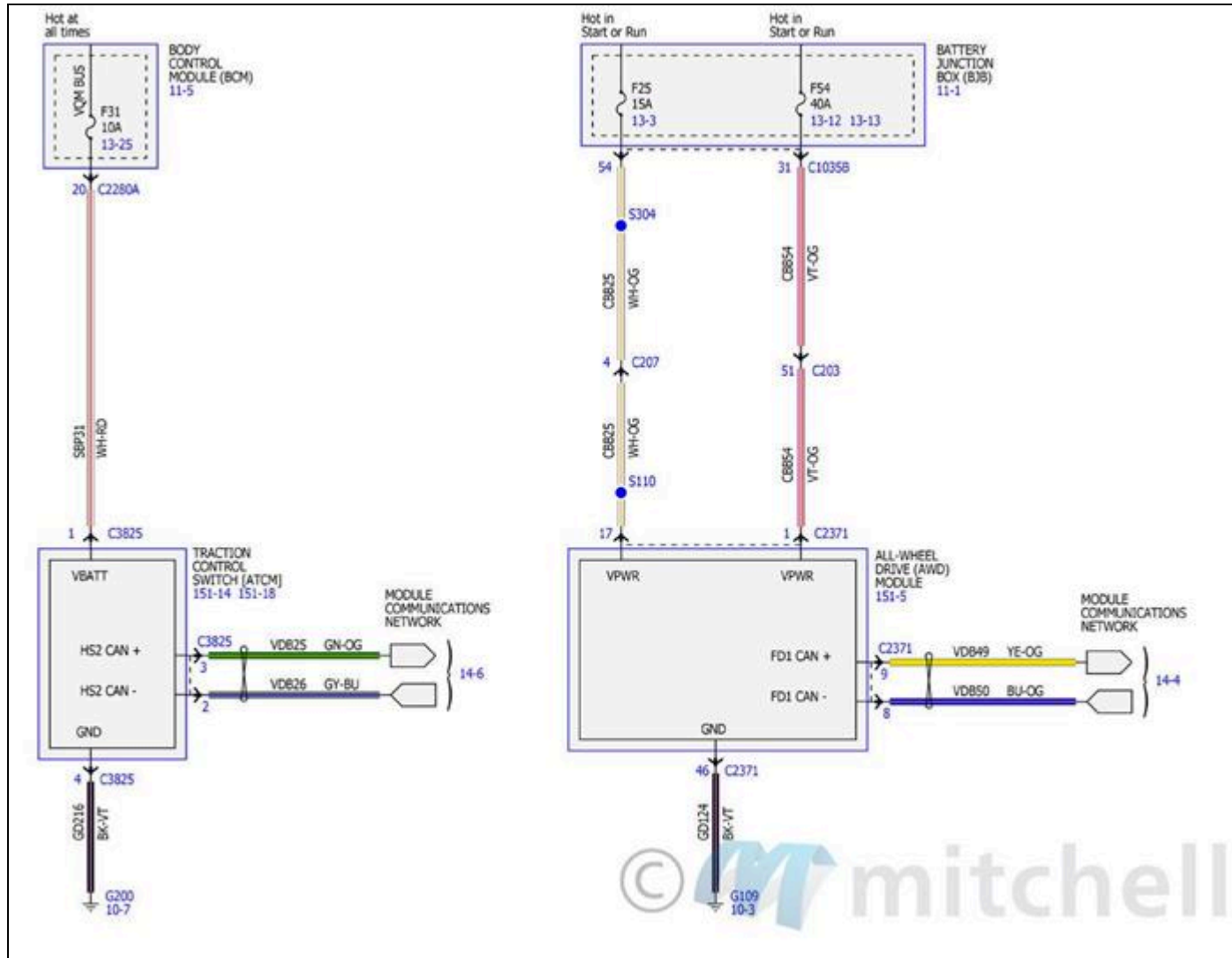

Fig. 81: Four Wheel Drive Systems Wiring Diagrams (2 Of 4)

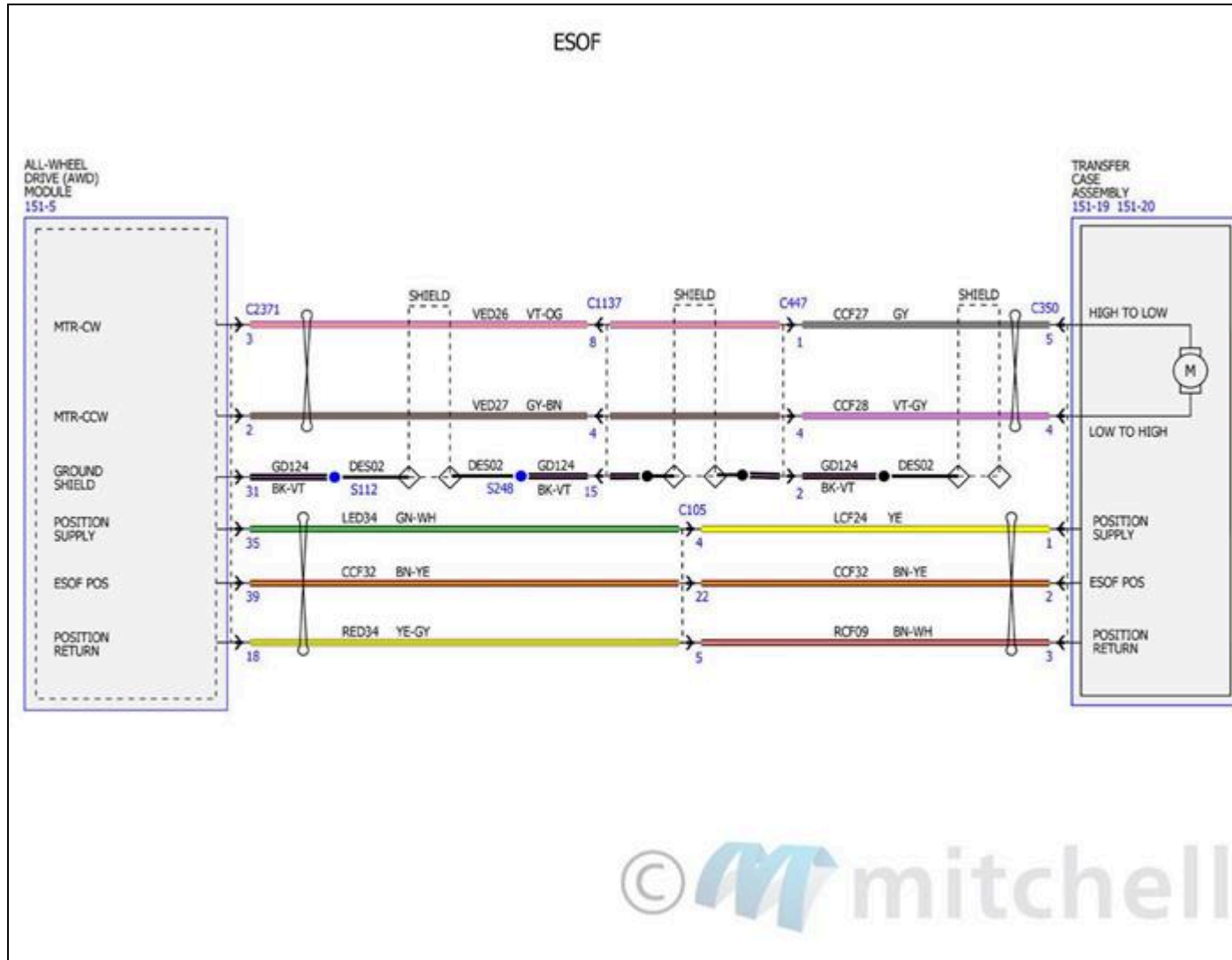

Fig. 82: Four Wheel Drive Systems Wiring Diagrams (3 Of 4)

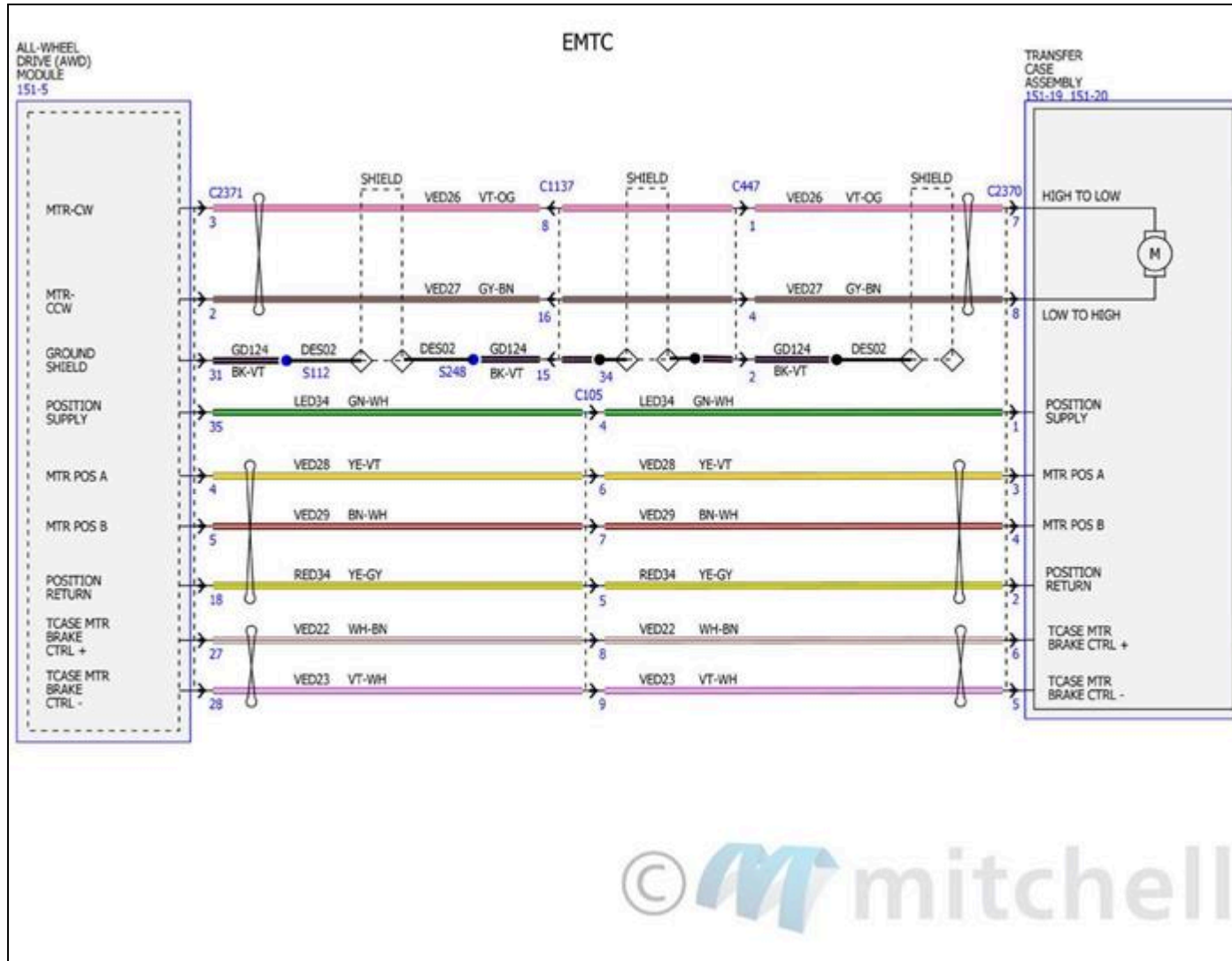
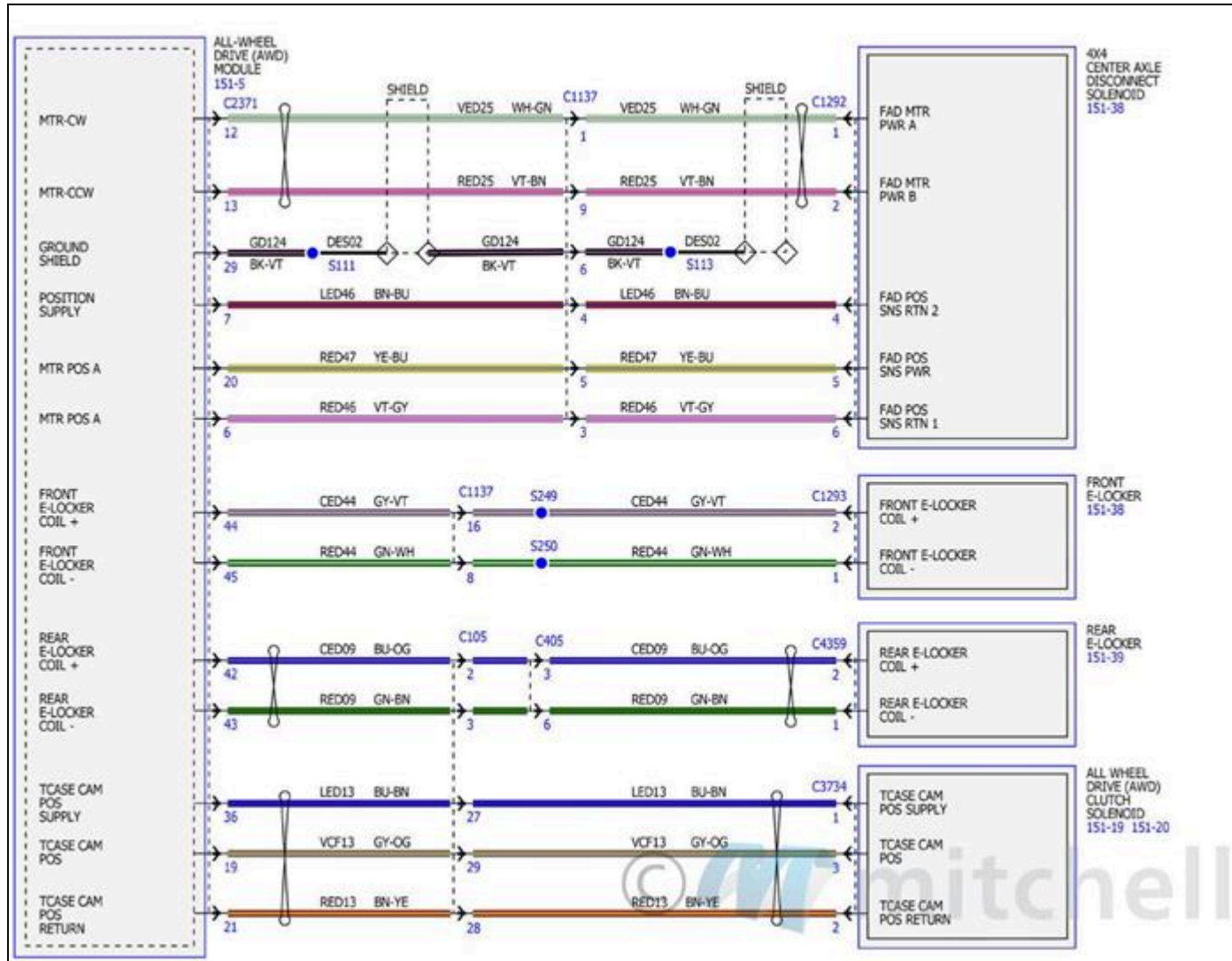

Fig. 83: Four Wheel Drive Systems Wiring Diagrams (4 Of 4)



HEADLAMPS/AUTOLAMPS

Fig. 84: Headlamps/Autolamps Wiring Diagrams (1 Of 4)

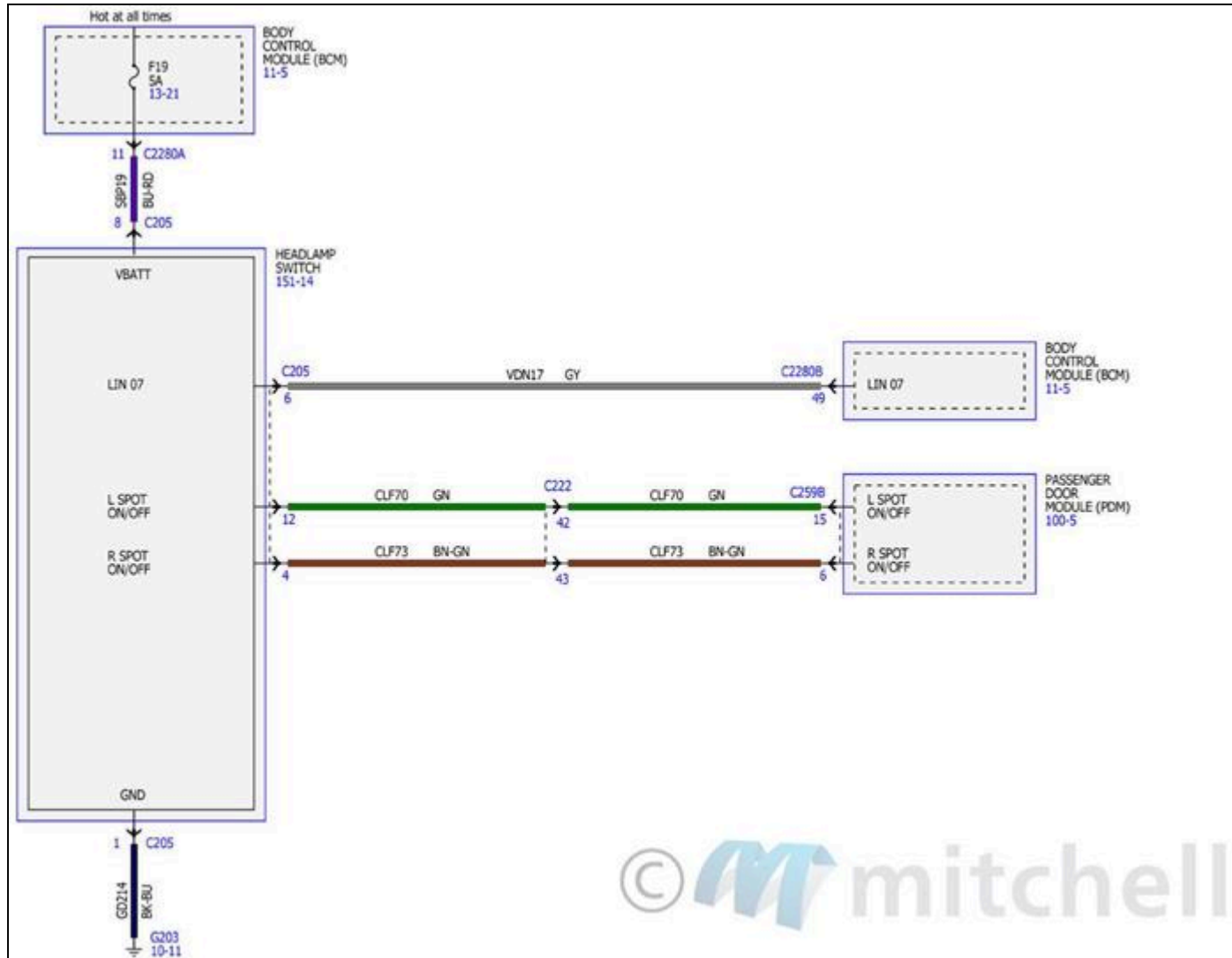

Fig. 85: Headlamps/Autolamps Wiring Diagrams (2 Of 4)

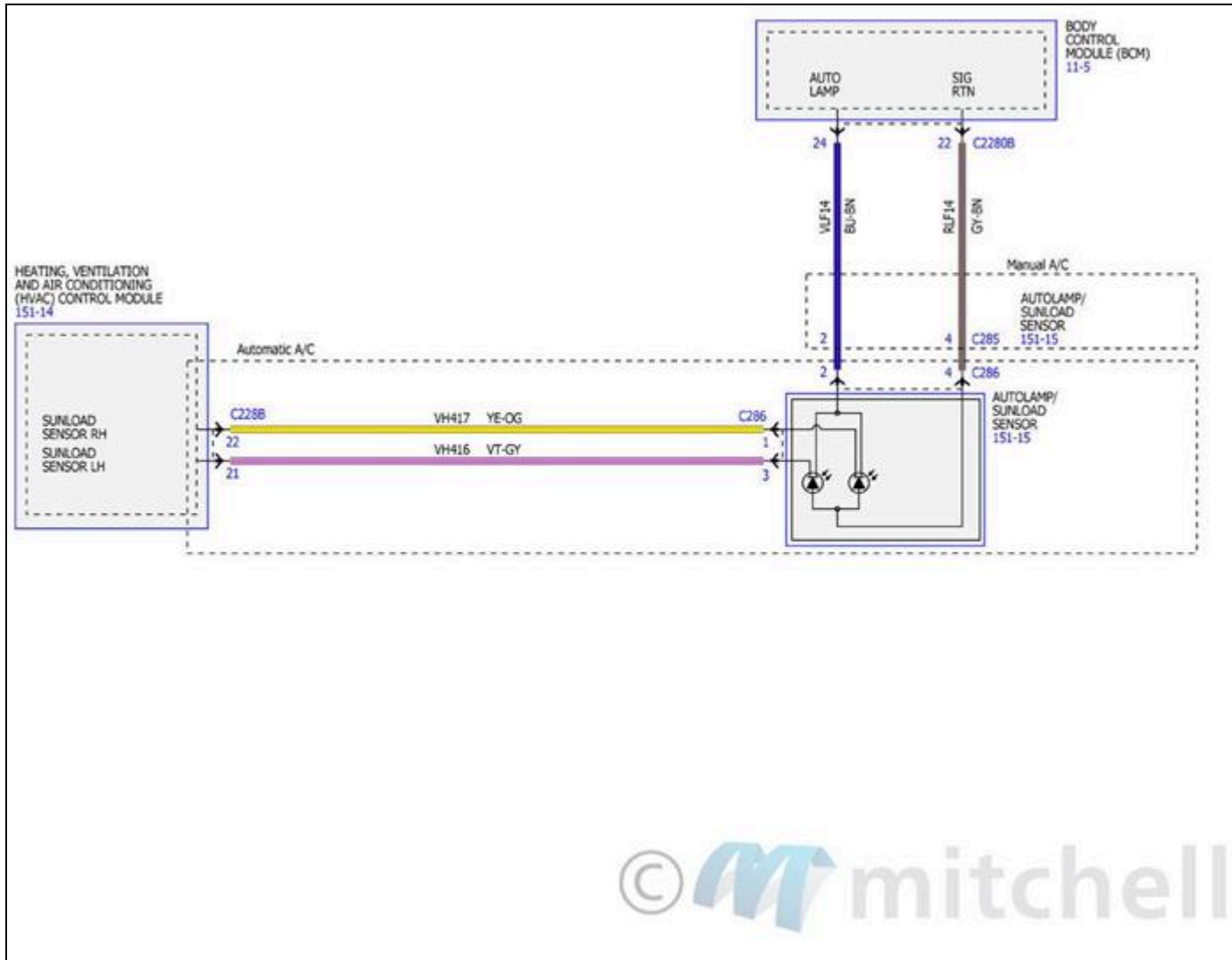

Fig. 86: Headlamps/Autolamps Wiring Diagrams (3 Of 4)

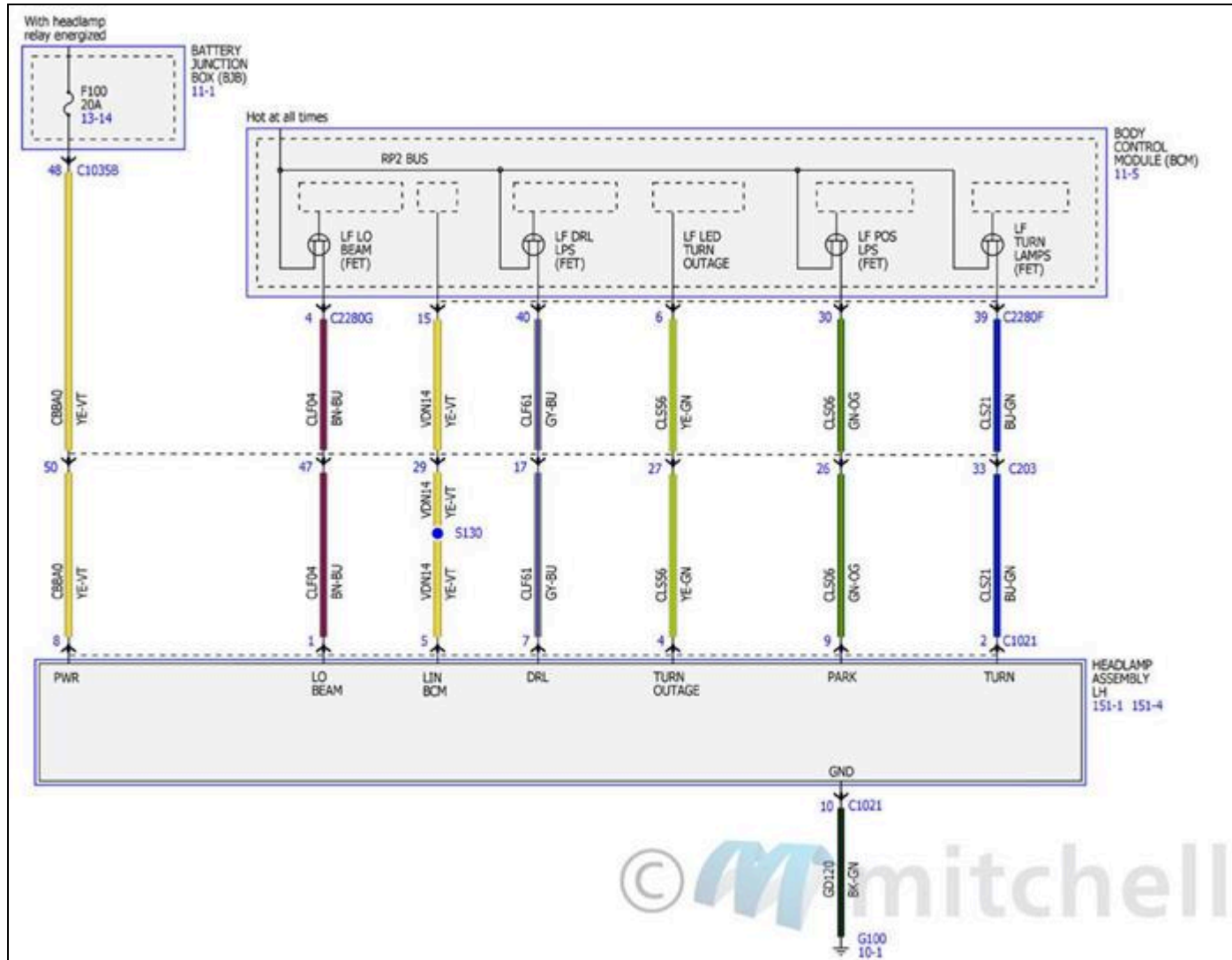
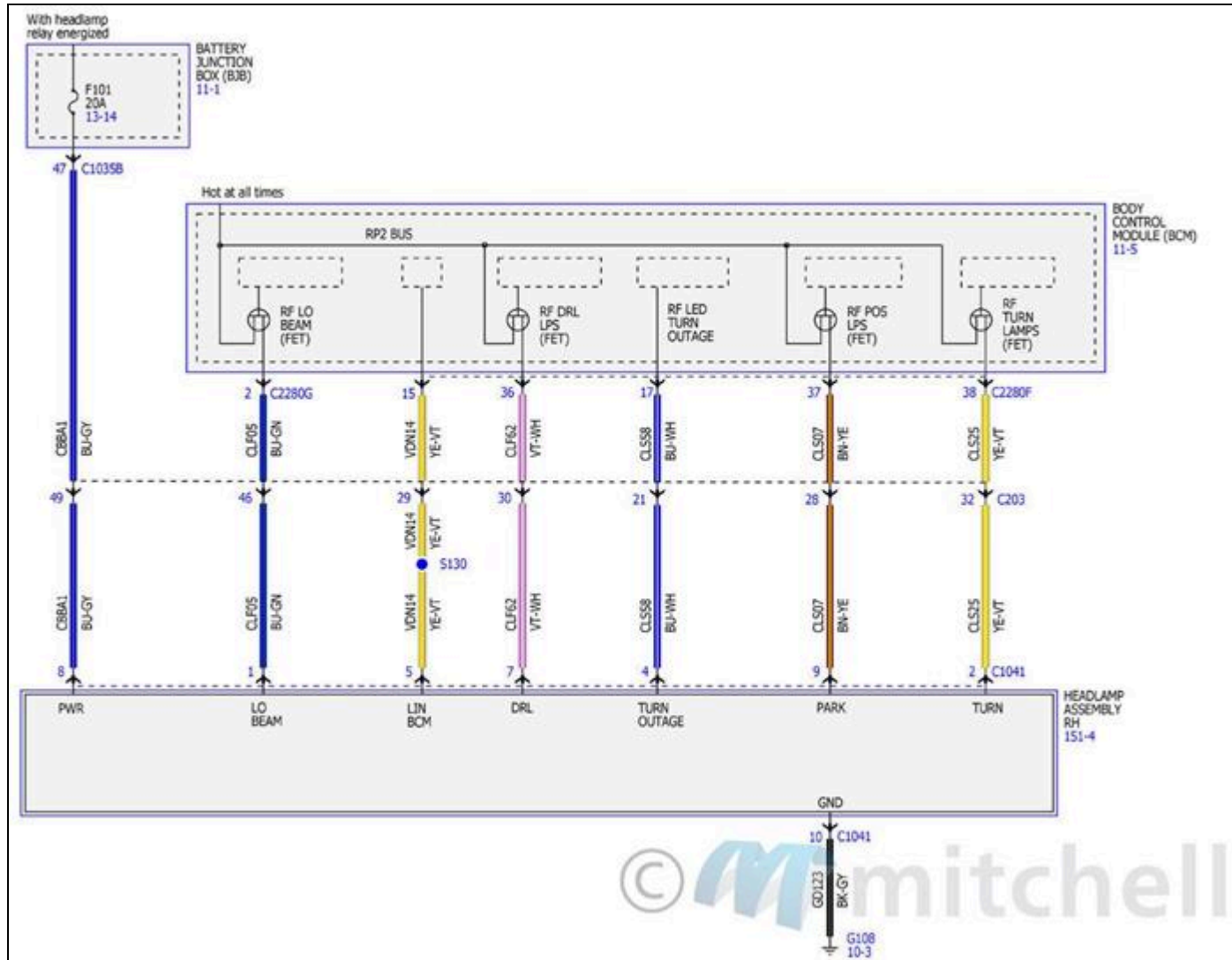
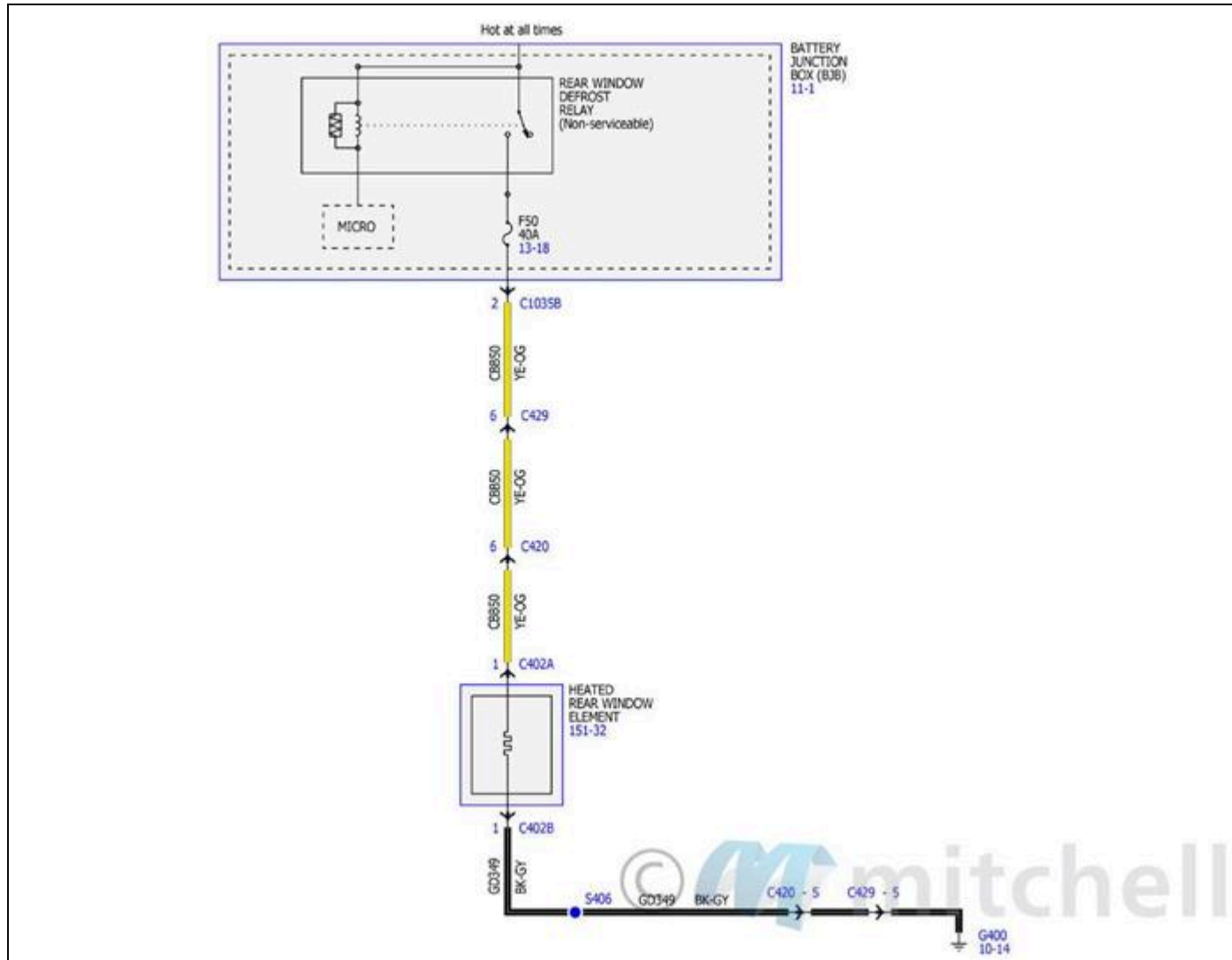

Fig. 87: Headlamps/Autolamps Wiring Diagrams (4 Of 4)



HEATED WINDOW

Fig. 88: Heated Window Wiring Diagram



HORN/CIGAR LIGHTER

Fig. 89: Horn/Cigar Lighter Wiring Diagrams (1 Of 5)

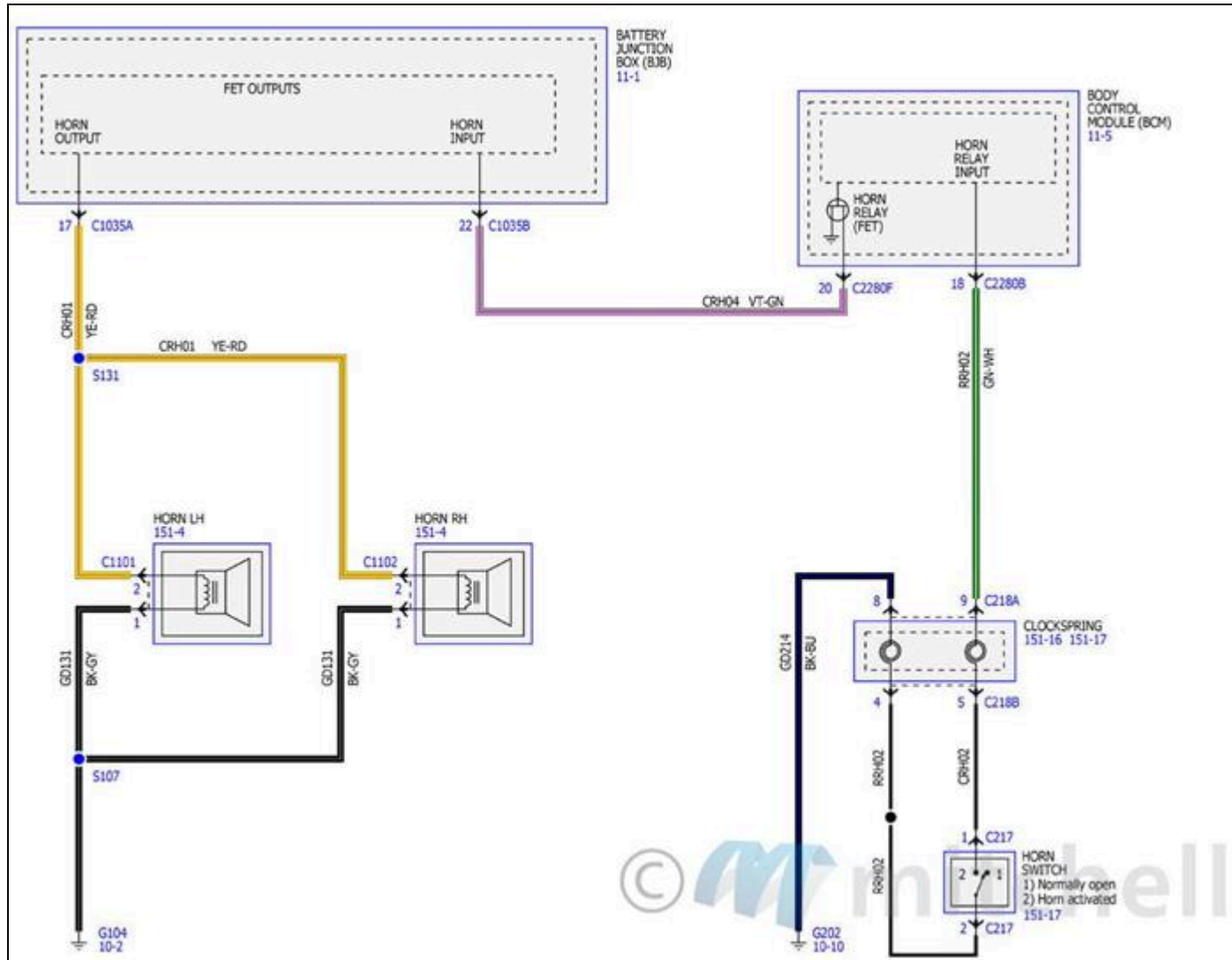

Fig. 90: Horn/Cigar Lighter Wiring Diagrams (2 Of 5)

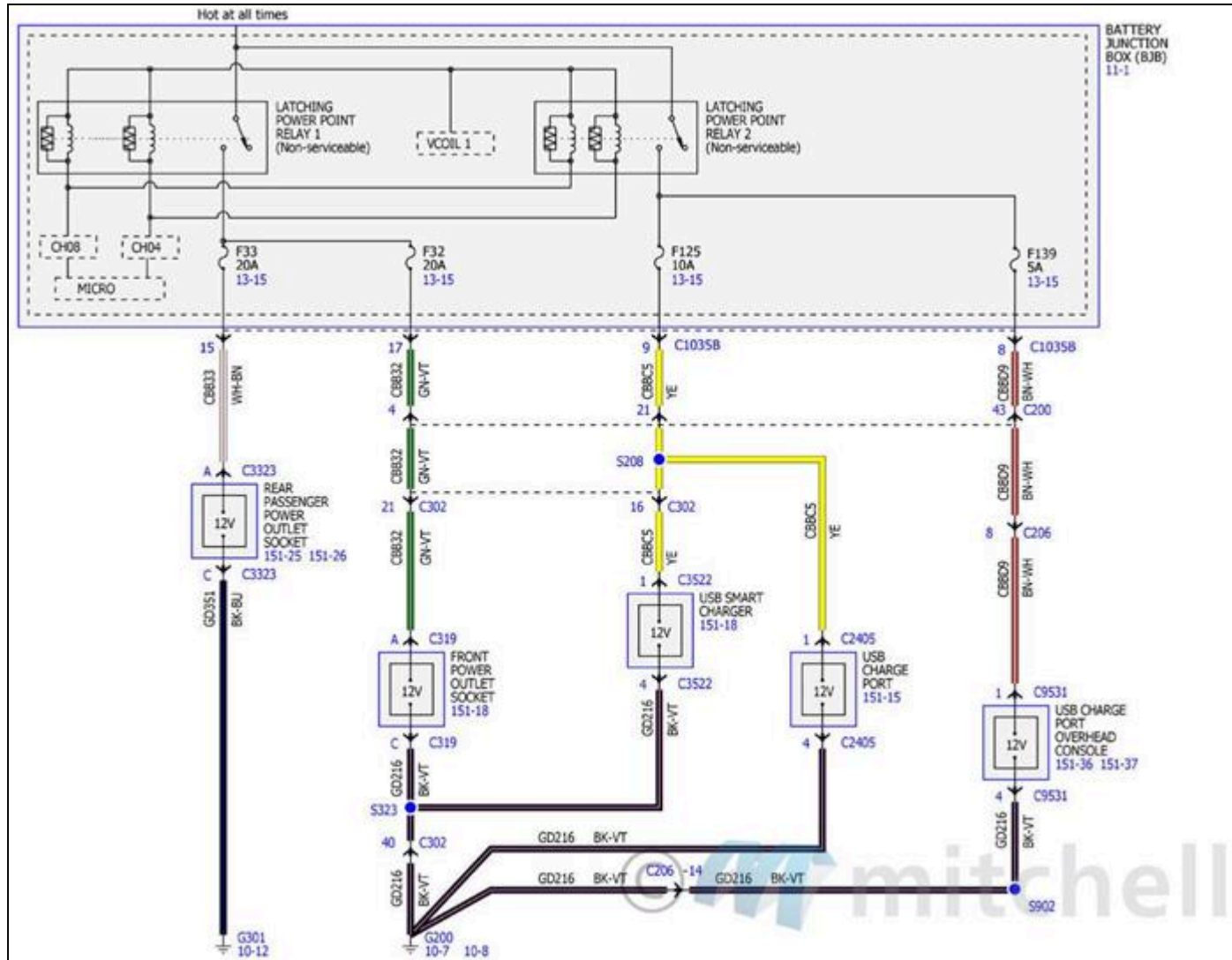

Fig. 91: Horn/Cigar Lighter Wiring Diagrams (3 Of 5)

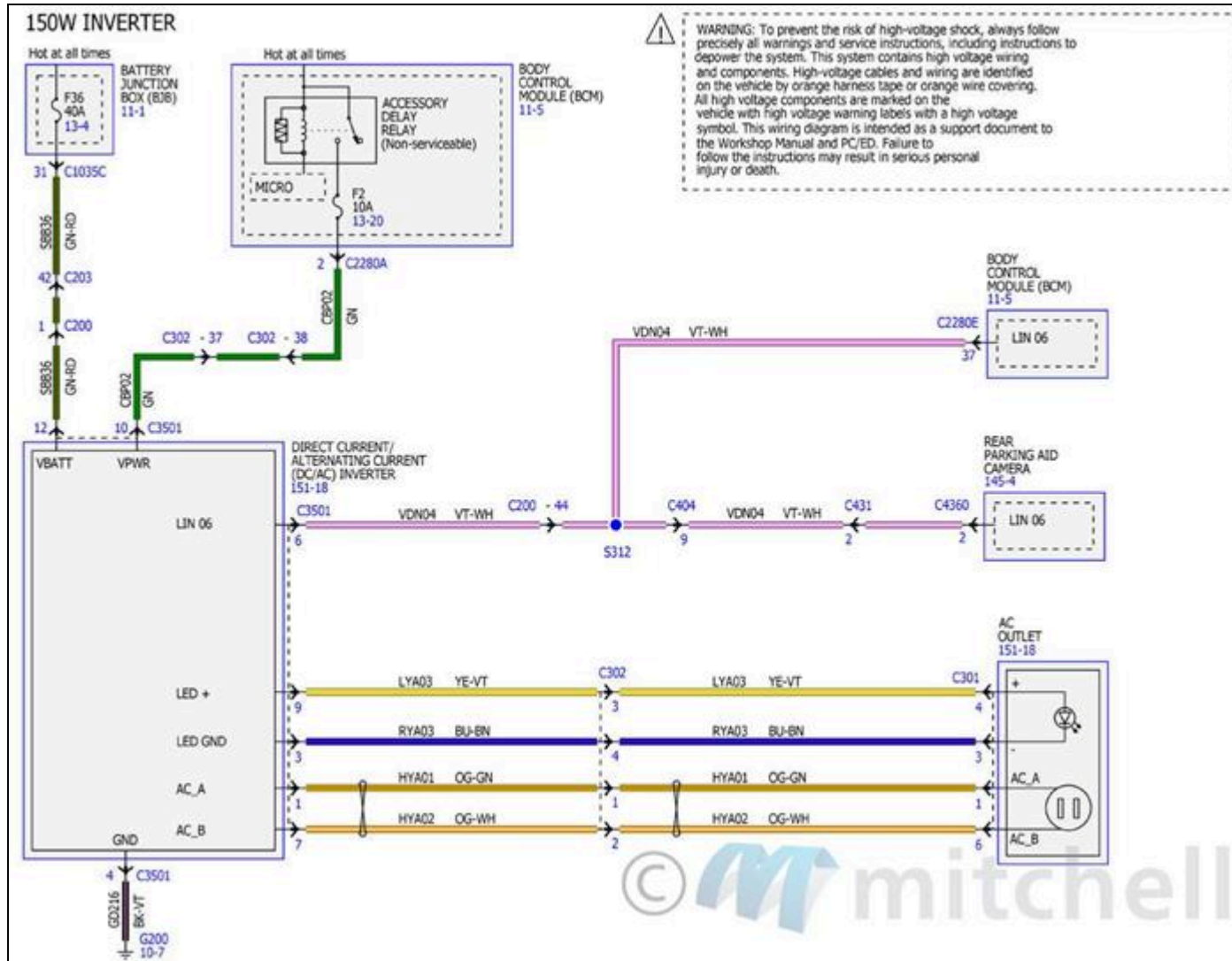

Fig. 92: Horn/Cigar Lighter Wiring Diagrams (4 Of 5)

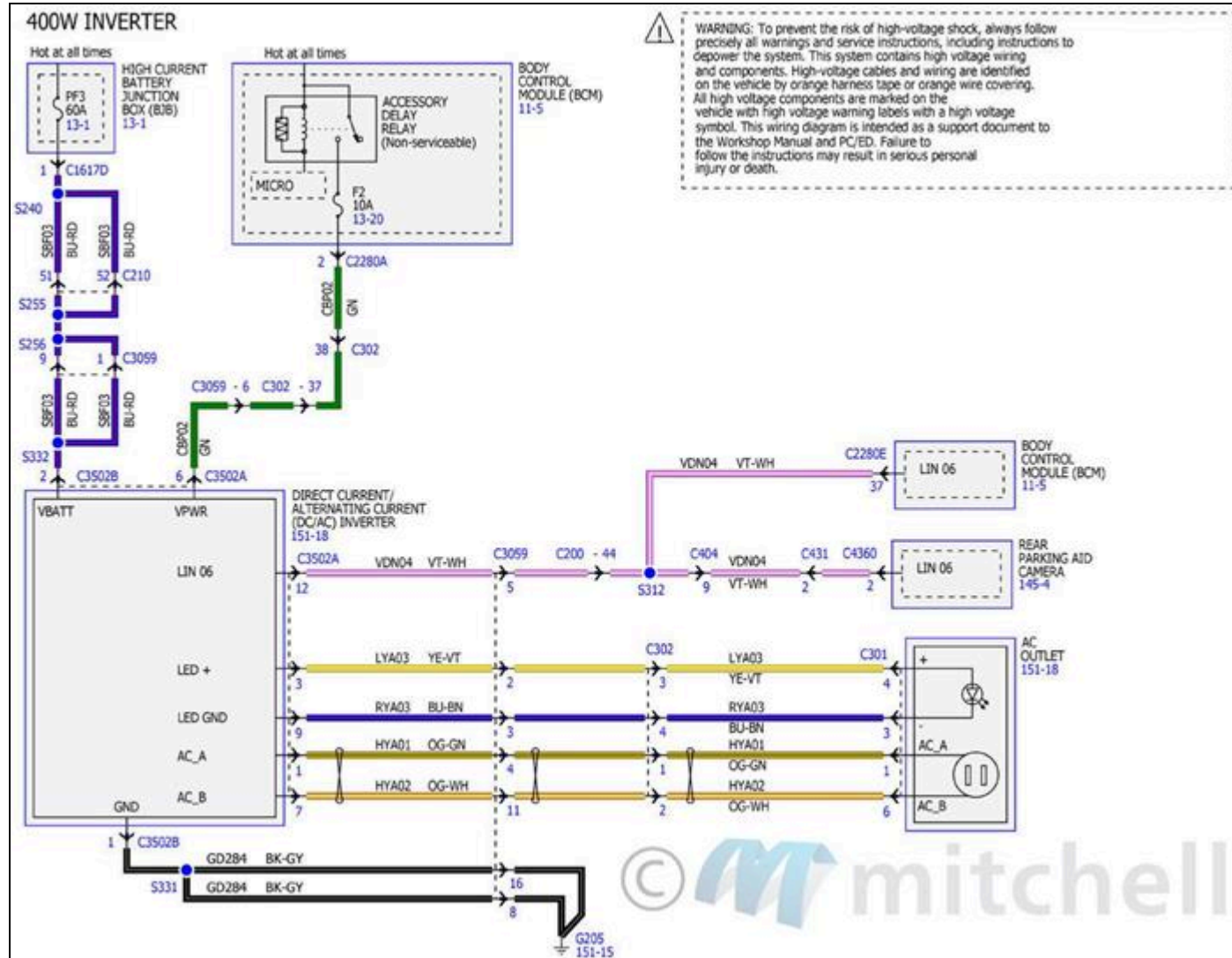
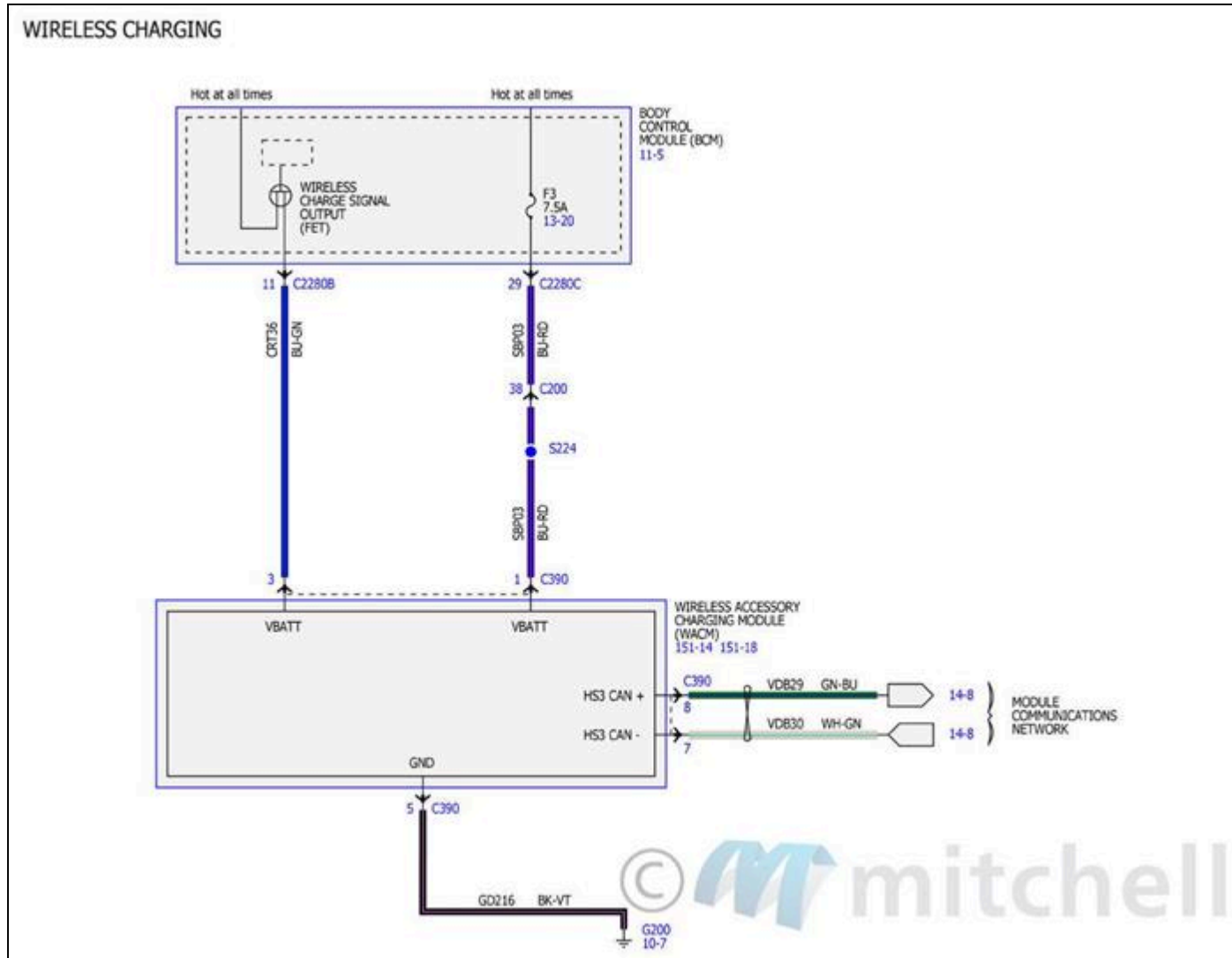

Fig. 93: Horn/Cigar Lighter Wiring Diagrams (5 Of 5)



INSTRUMENT CLUSTER

Fig. 94: Instrument Cluster Wiring Diagrams (1 Of 4)

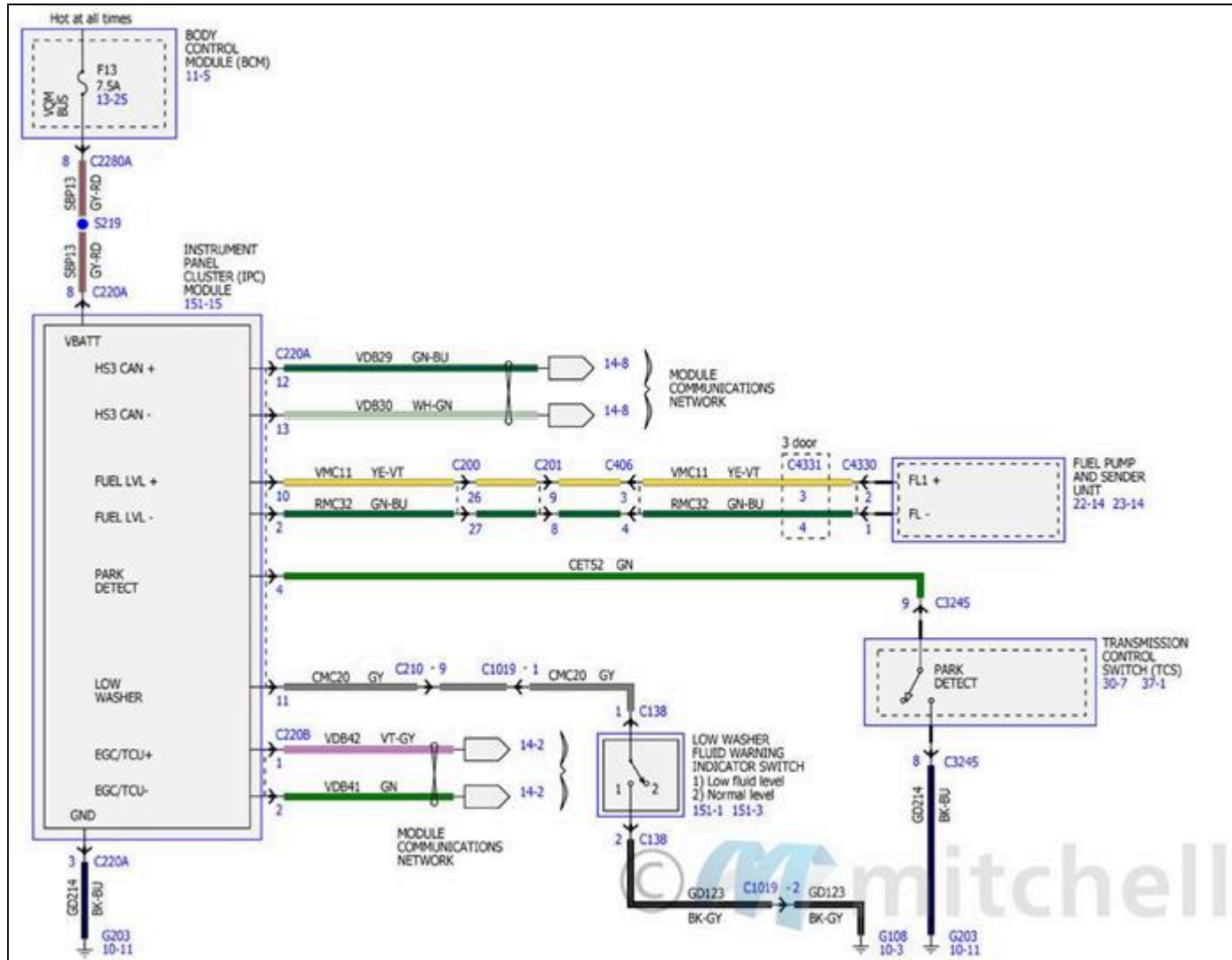

Fig. 95: Instrument Cluster Wiring Diagrams (2 Of 4)

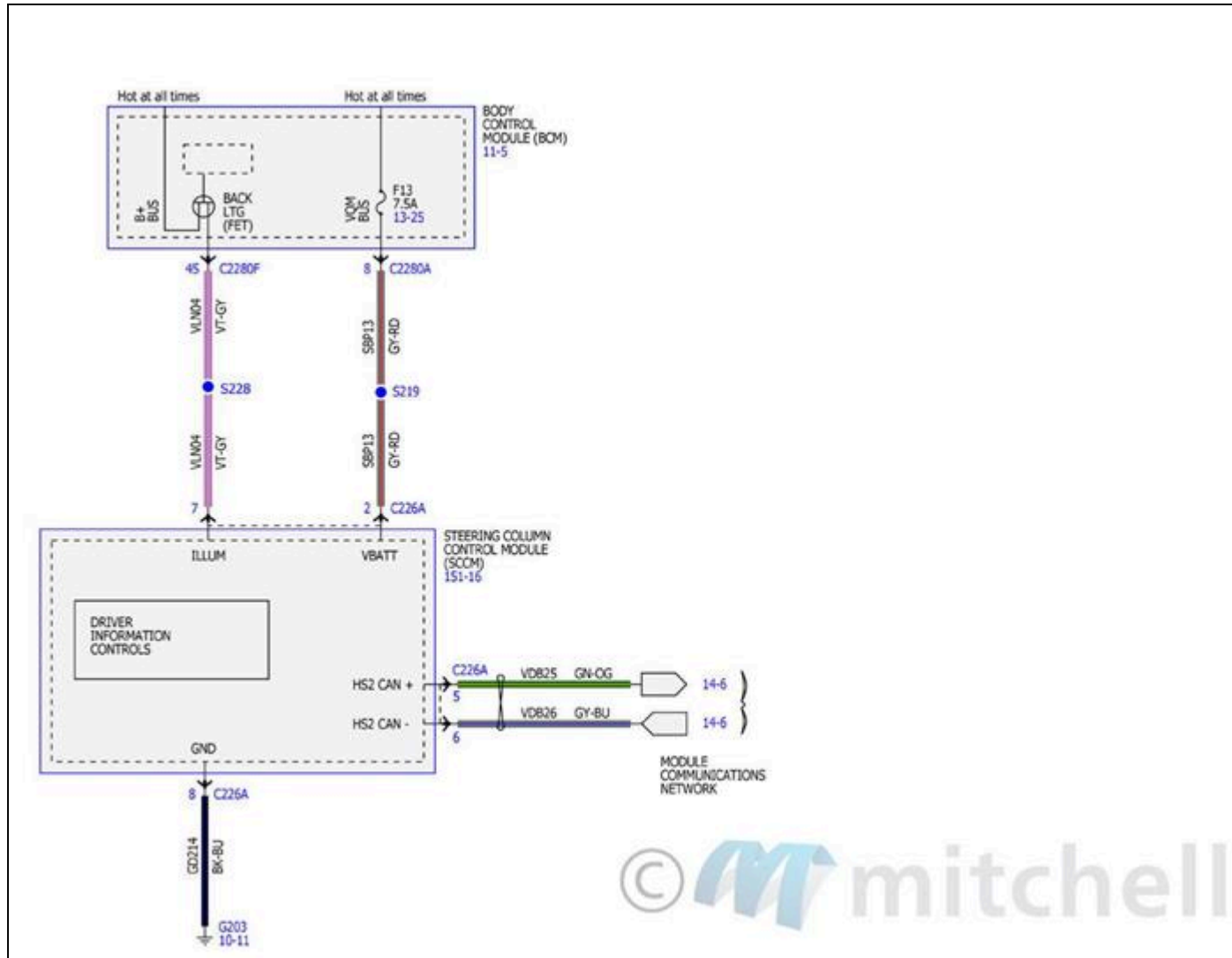

Fig. 96: Instrument Cluster Wiring Diagrams (3 Of 4)

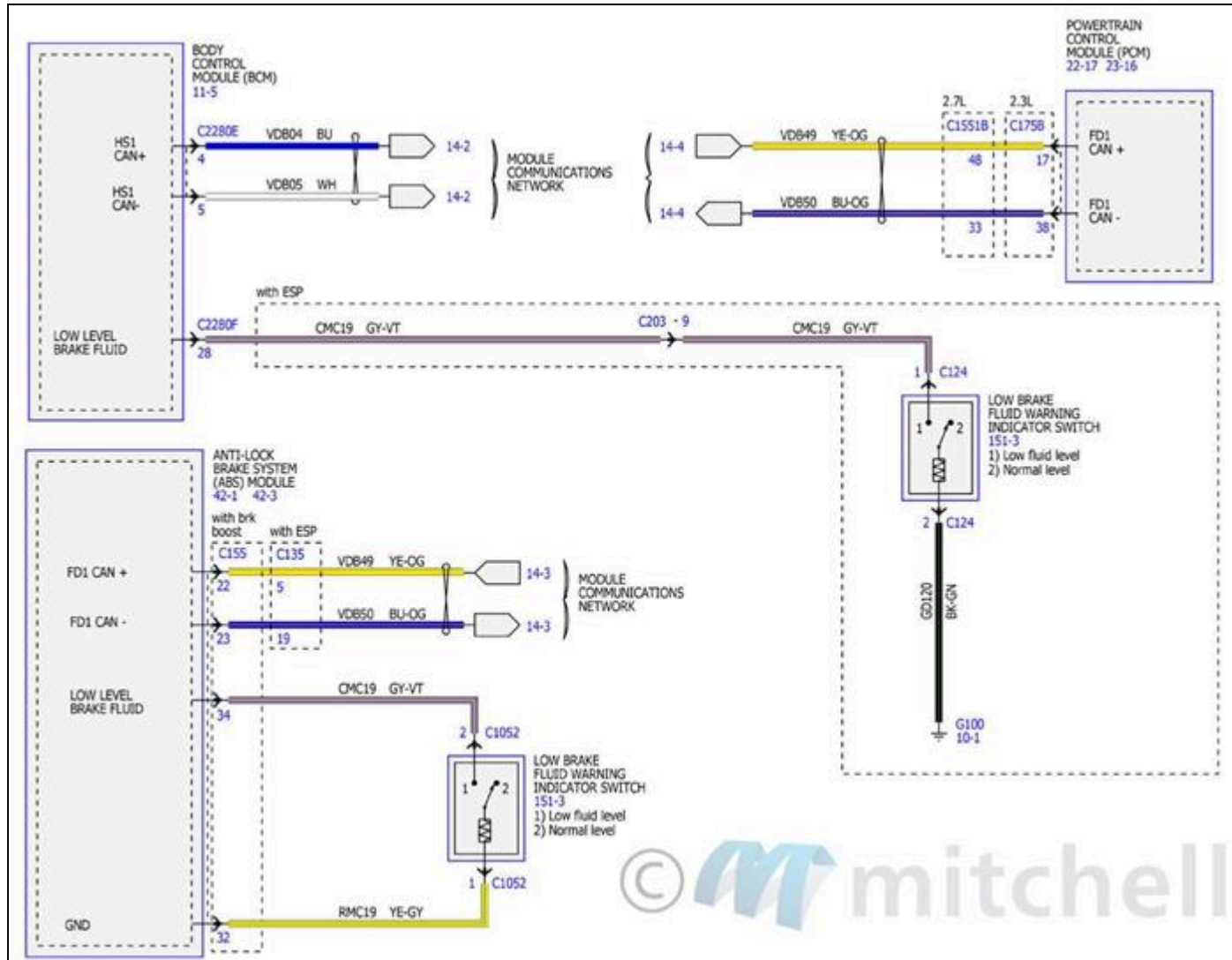
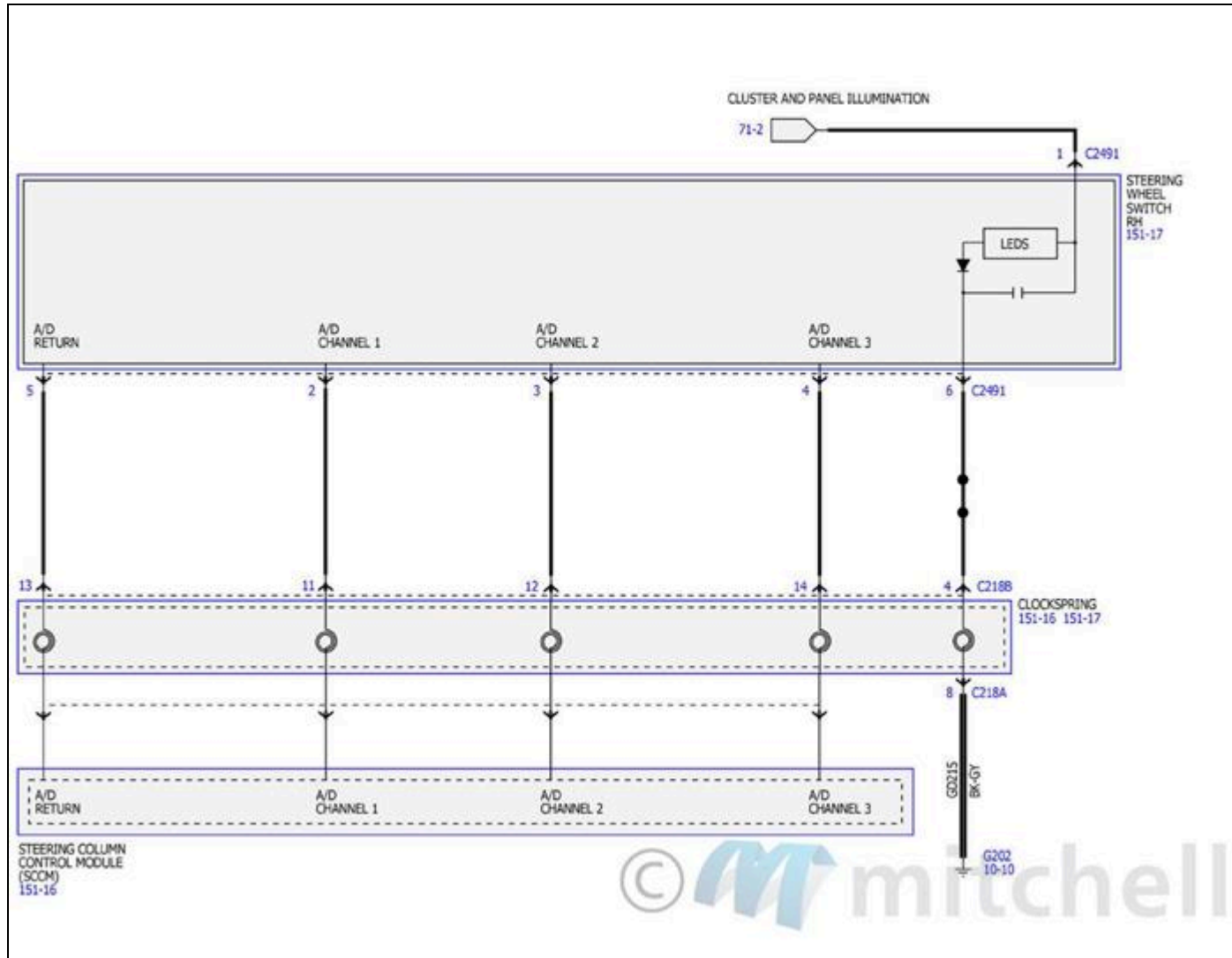

Fig. 97: Instrument Cluster Wiring Diagrams (4 Of 4)



INTERIOR LAMPS

Fig. 98: Interior Lamps Wiring Diagrams (1 Of 4)

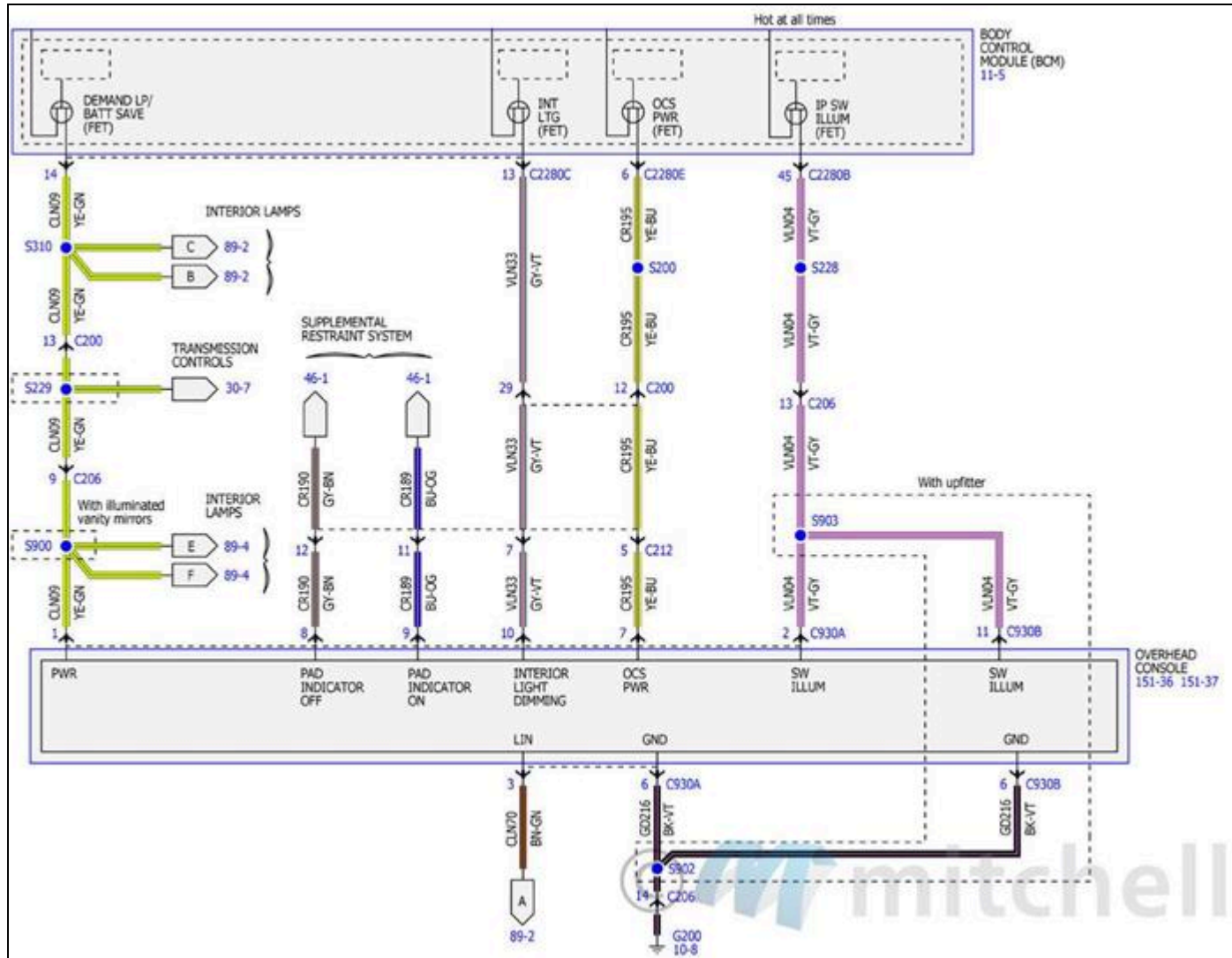

Fig. 99: Interior Lamps Wiring Diagrams (2 Of 4)

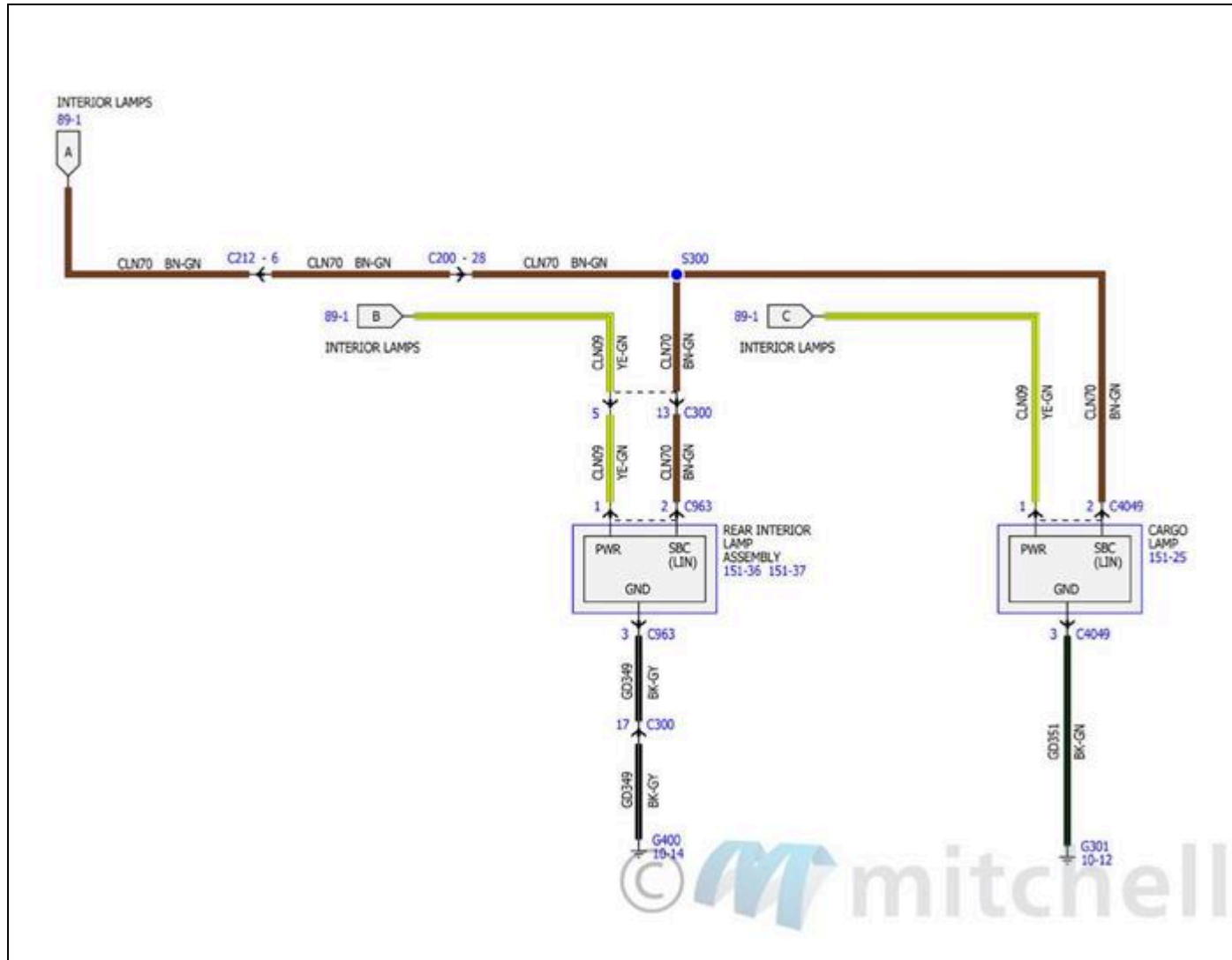

Fig. 100: Interior Lamps Wiring Diagrams (3 Of 4)

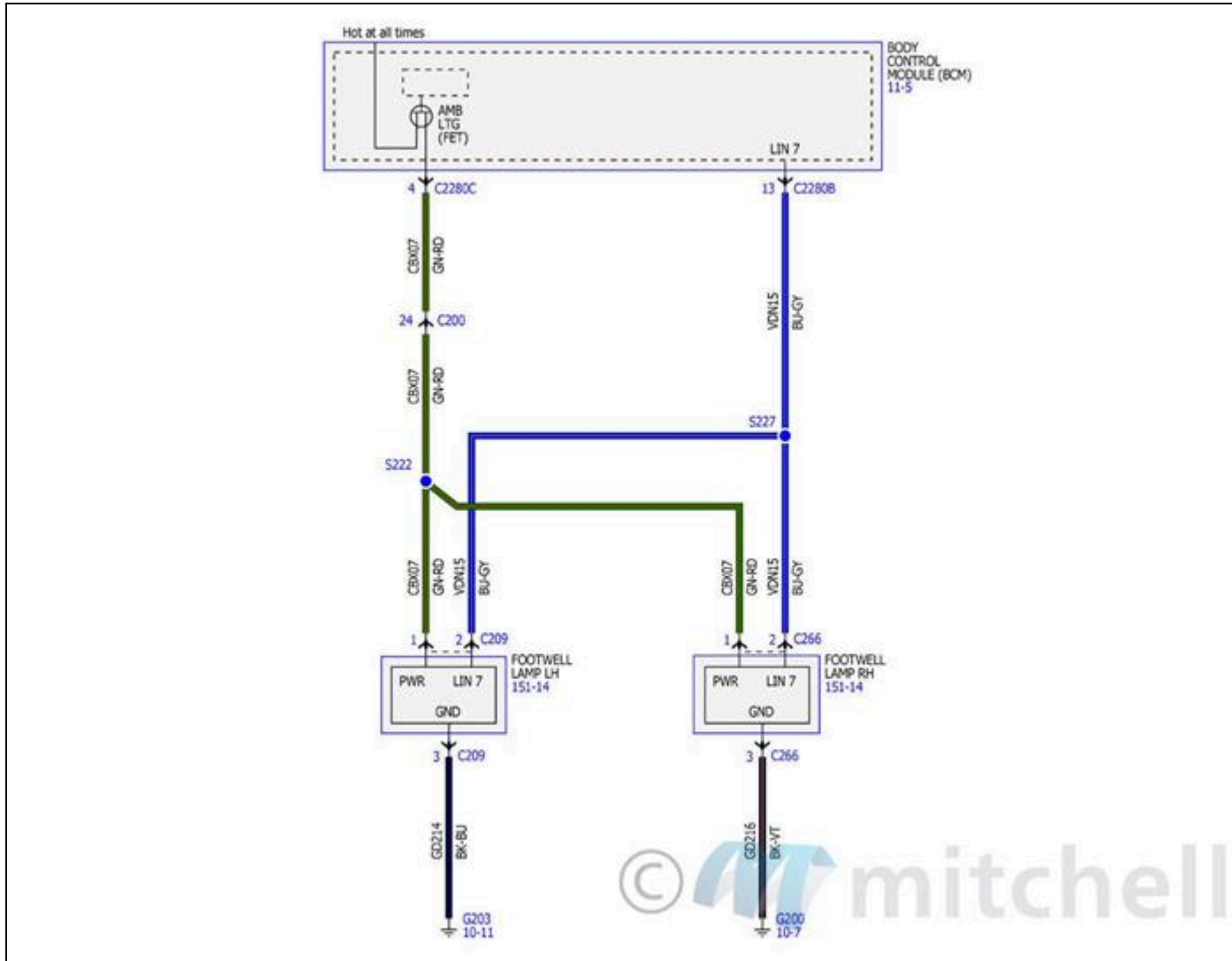
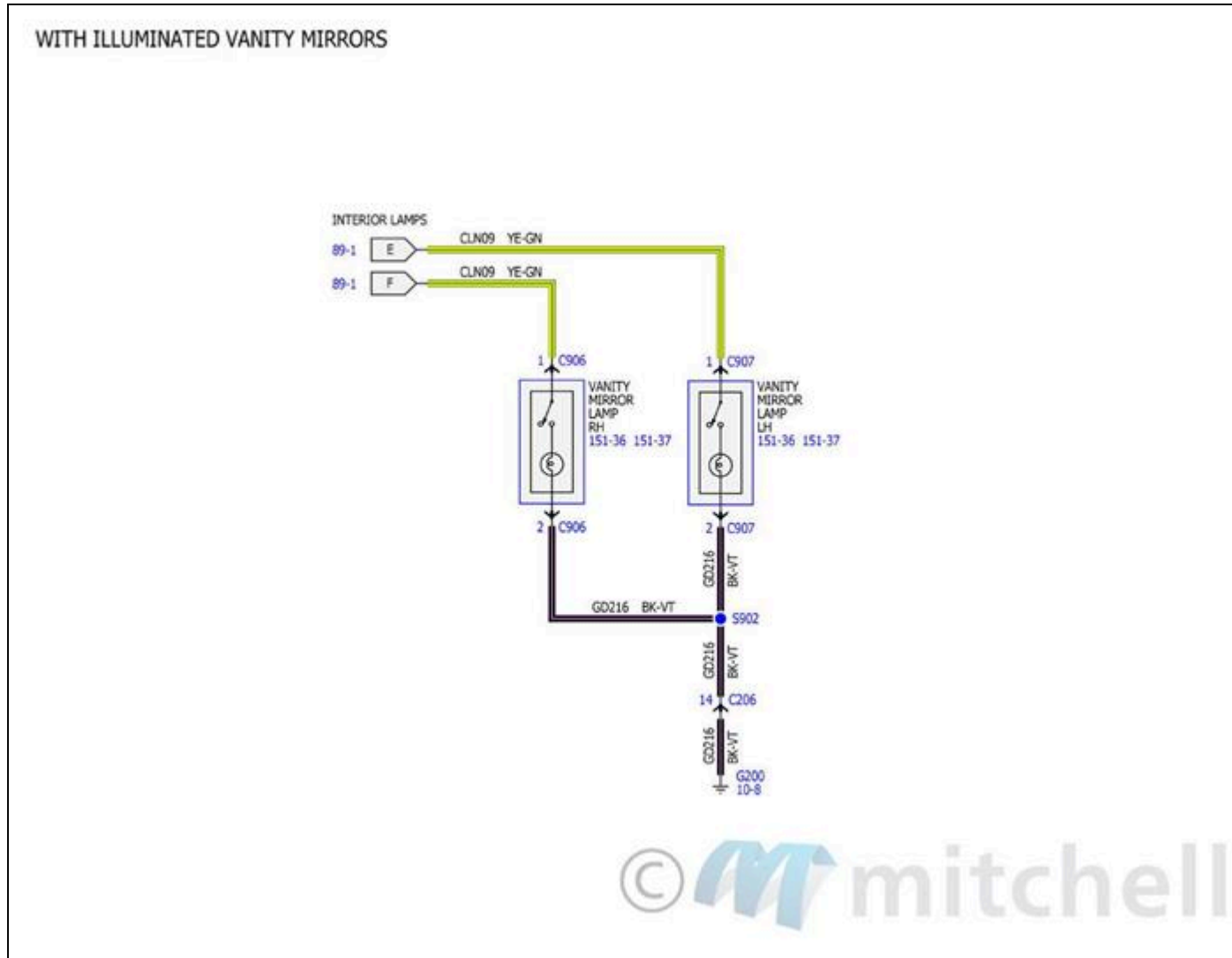

Fig. 101: Interior Lamps Wiring Diagrams (4 Of 4)



MANUAL CLIMATE CONTROL SYSTEM

Fig. 102: Manual Climate Control System Wiring Diagrams (1 Of 5)

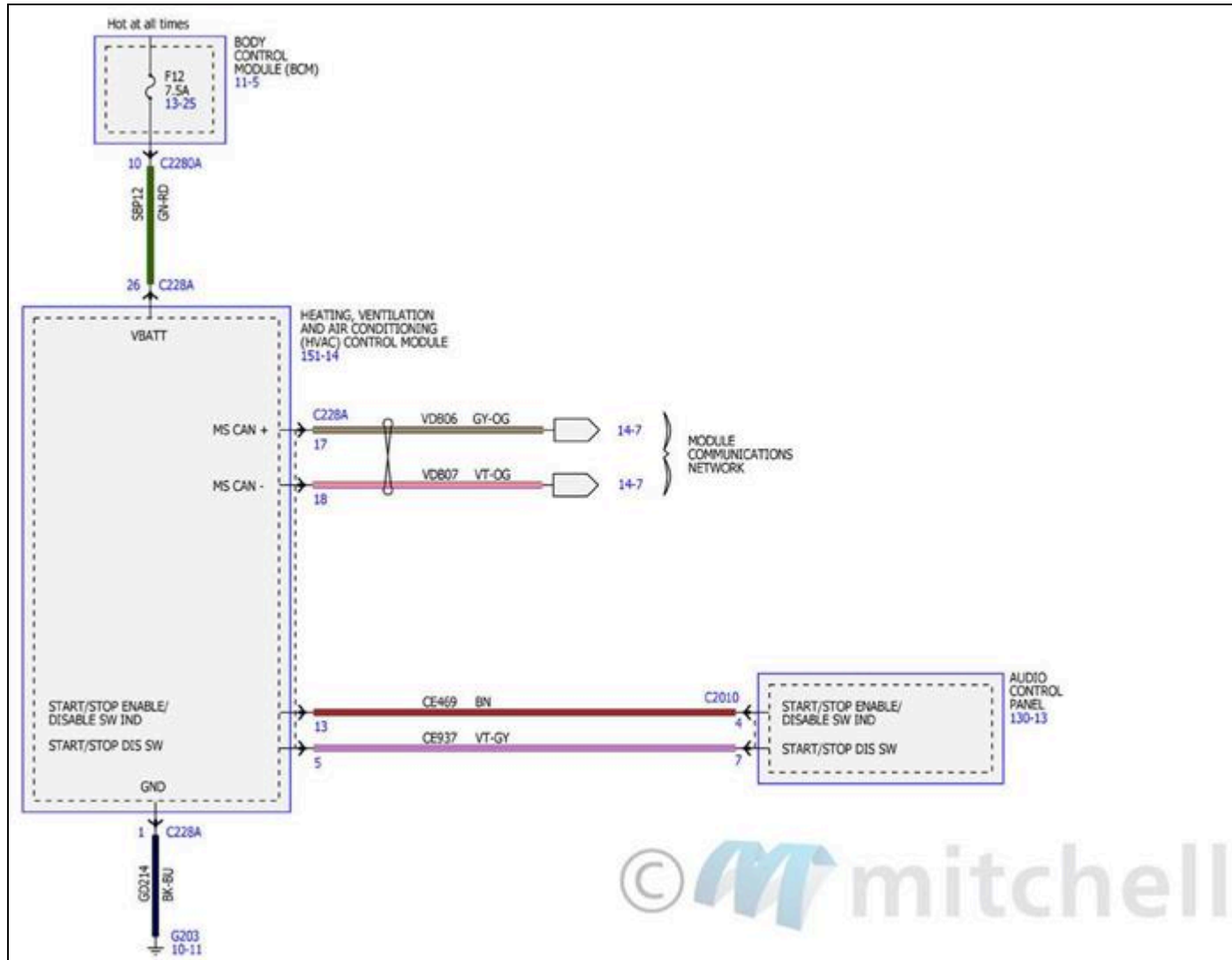

Fig. 103: Manual Climate Control System Wiring Diagrams (2 Of 5)

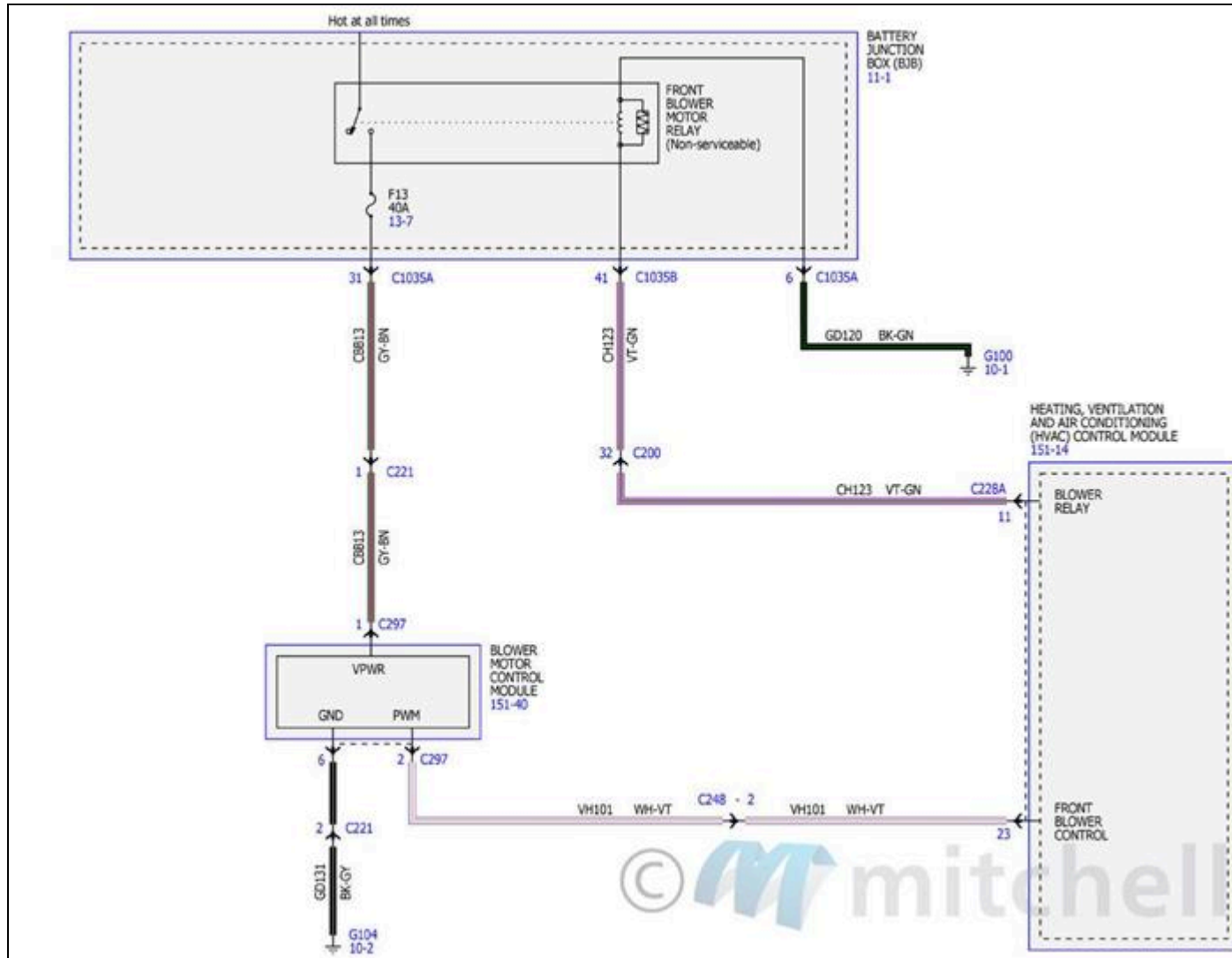

Fig. 104: Manual Climate Control System Wiring Diagrams (3 Of 5)

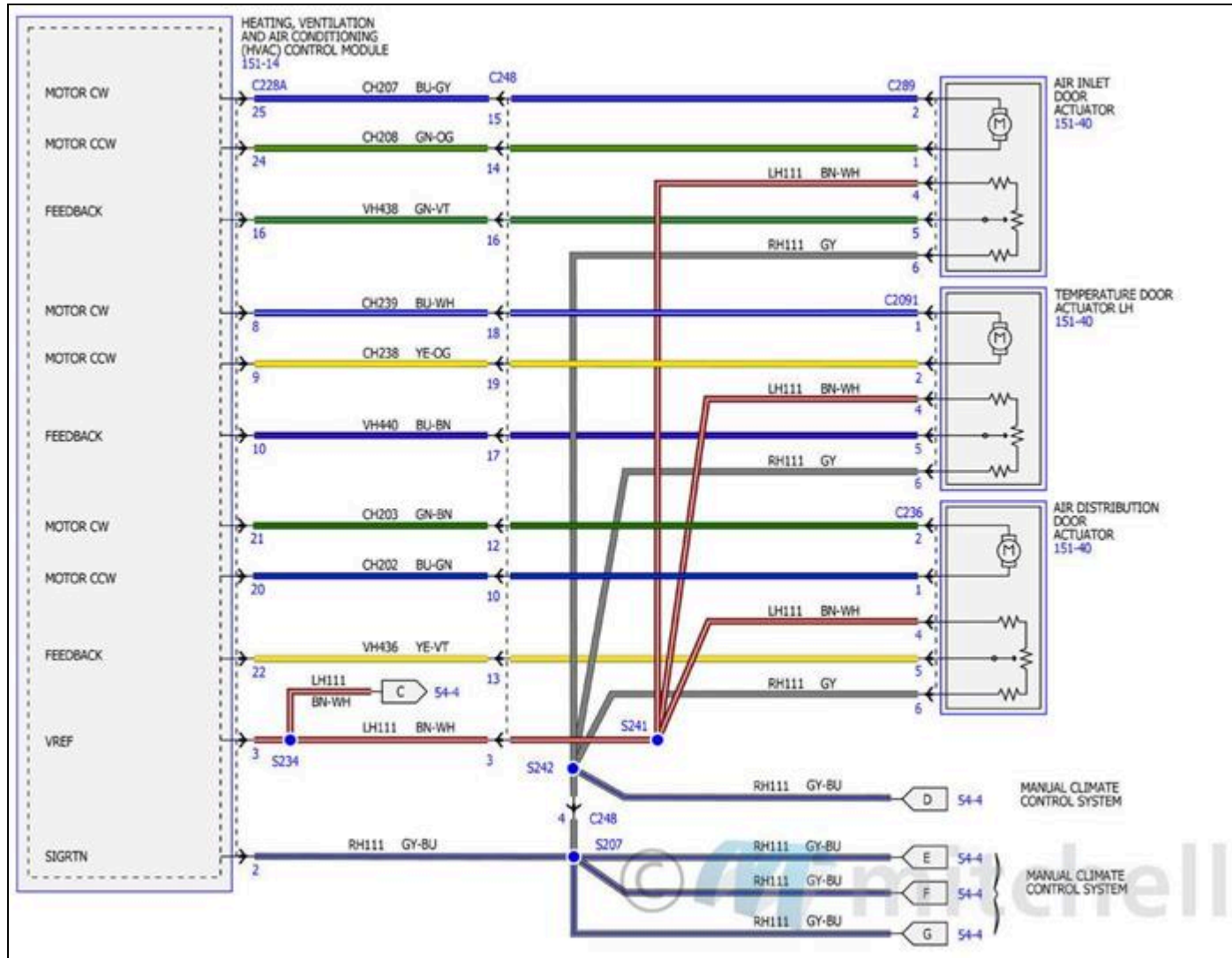

Fig. 105: Manual Climate Control System Wiring Diagrams (4 Of 5)

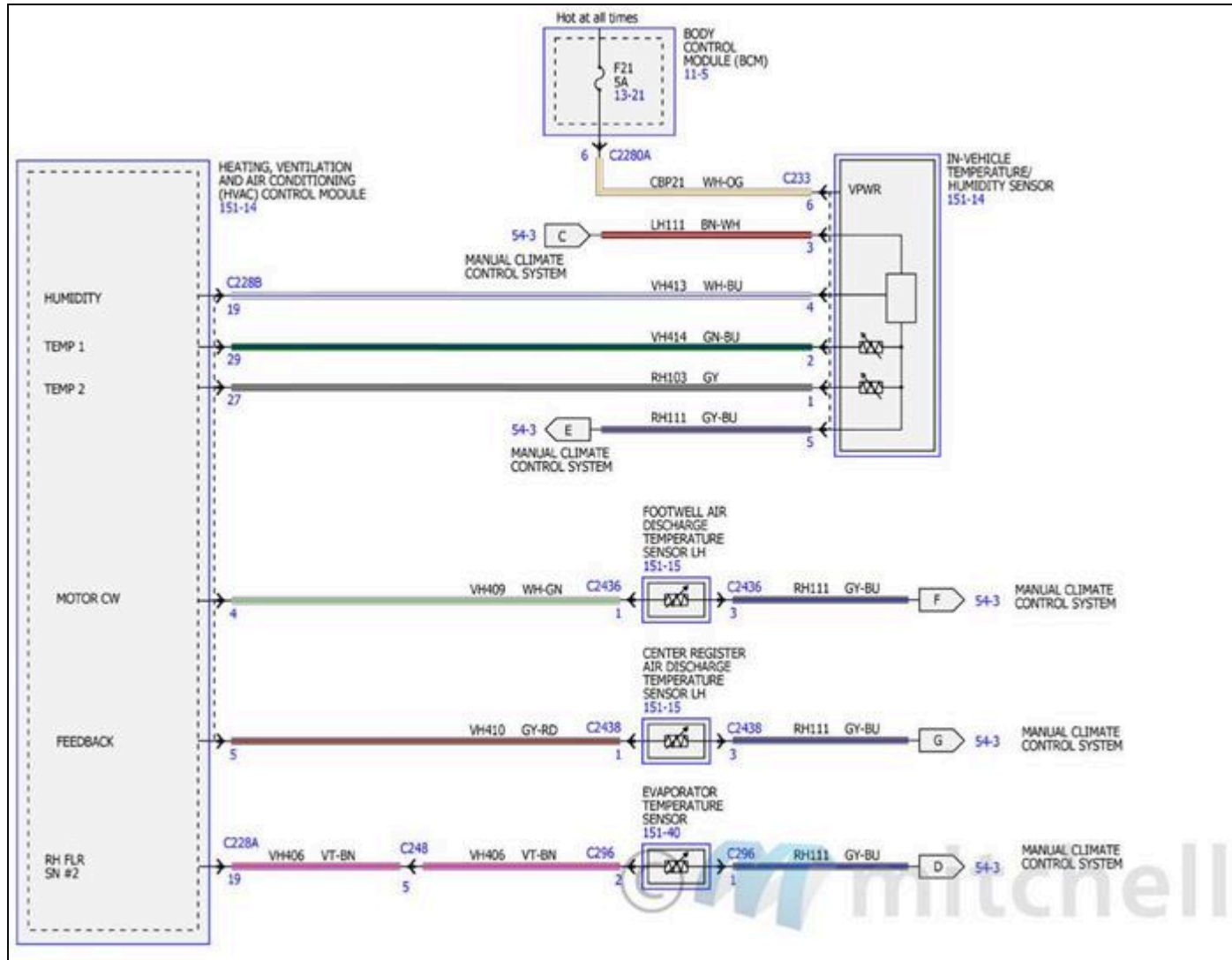
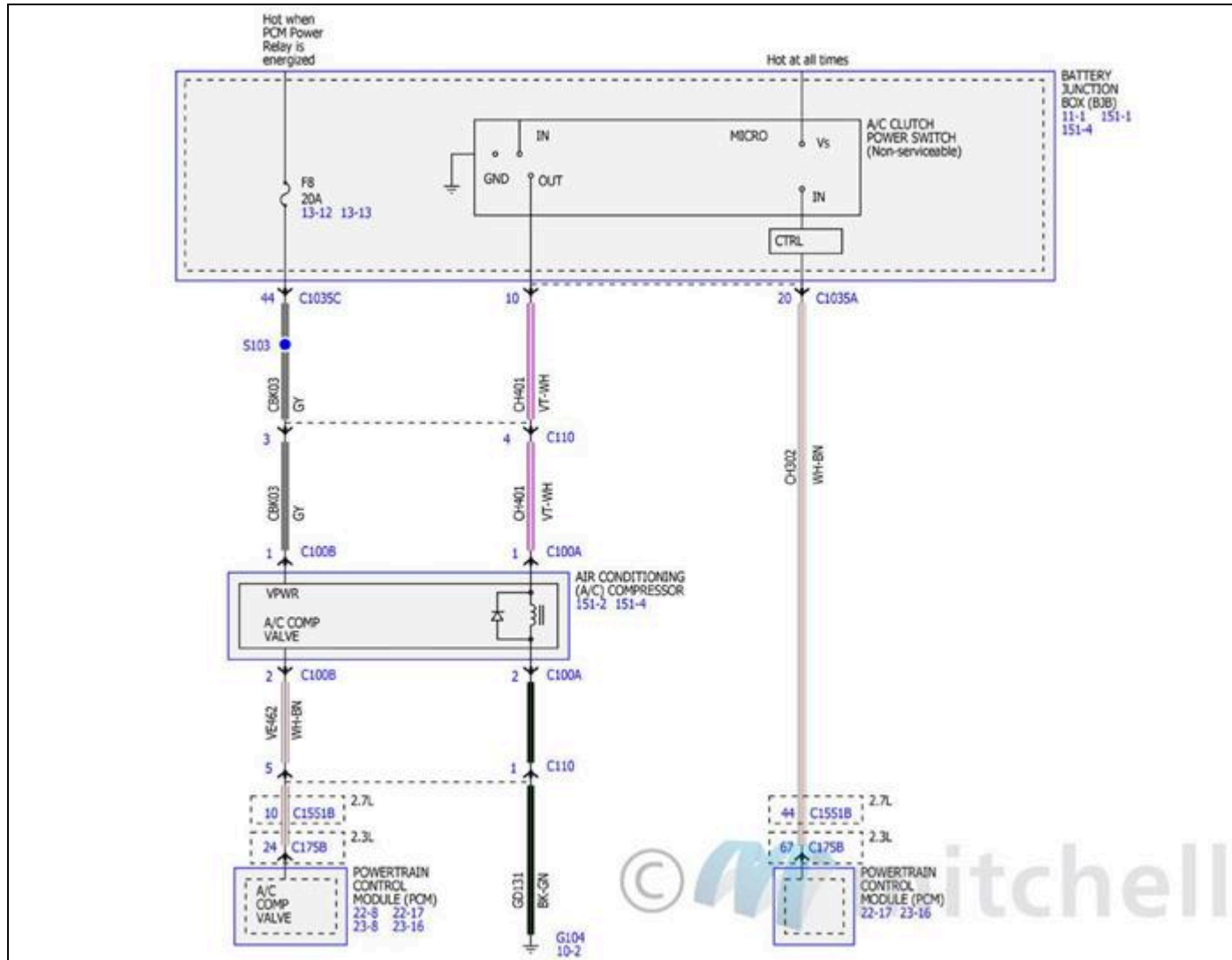

Fig. 106: Manual Climate Control System Wiring Diagrams (5 Of 5)



MODULE COMMUNICATIONS NETWORK

Fig. 107: Module Communications Network Wiring Diagrams (1 Of 8)

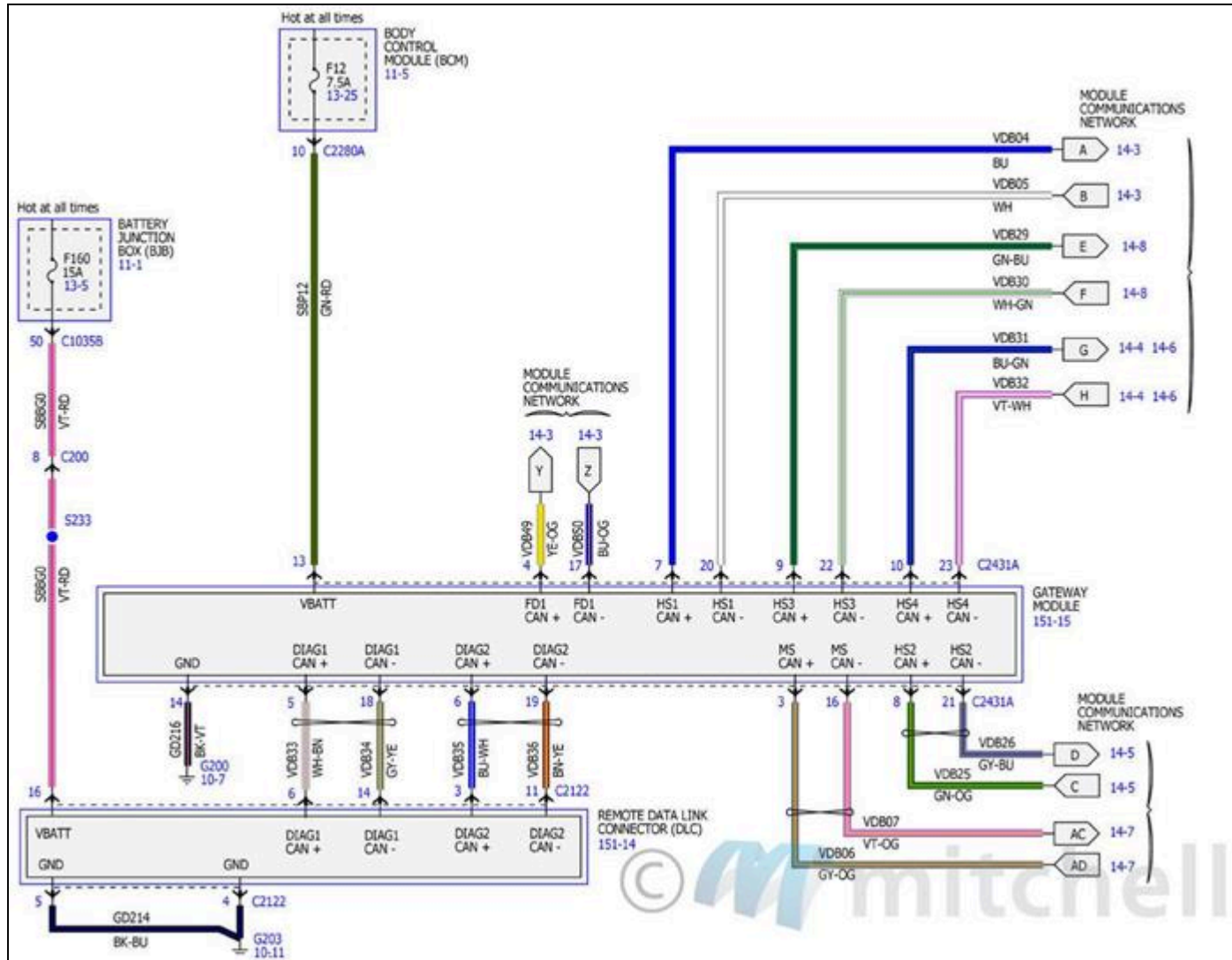

Fig. 108: Module Communications Network Wiring Diagrams (2 Of 8)

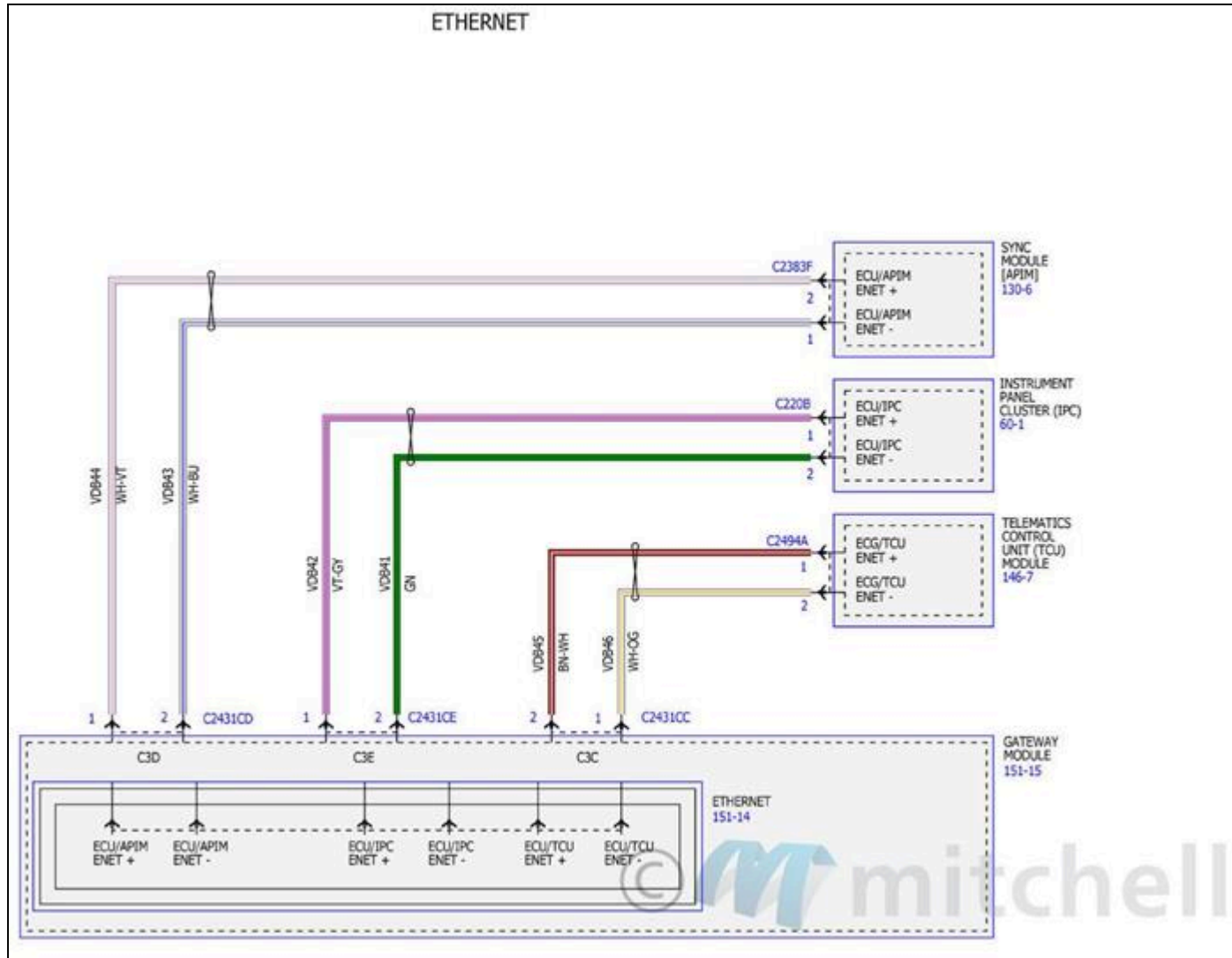

Fig. 109: Module Communications Network Wiring Diagrams (3 Of 8)

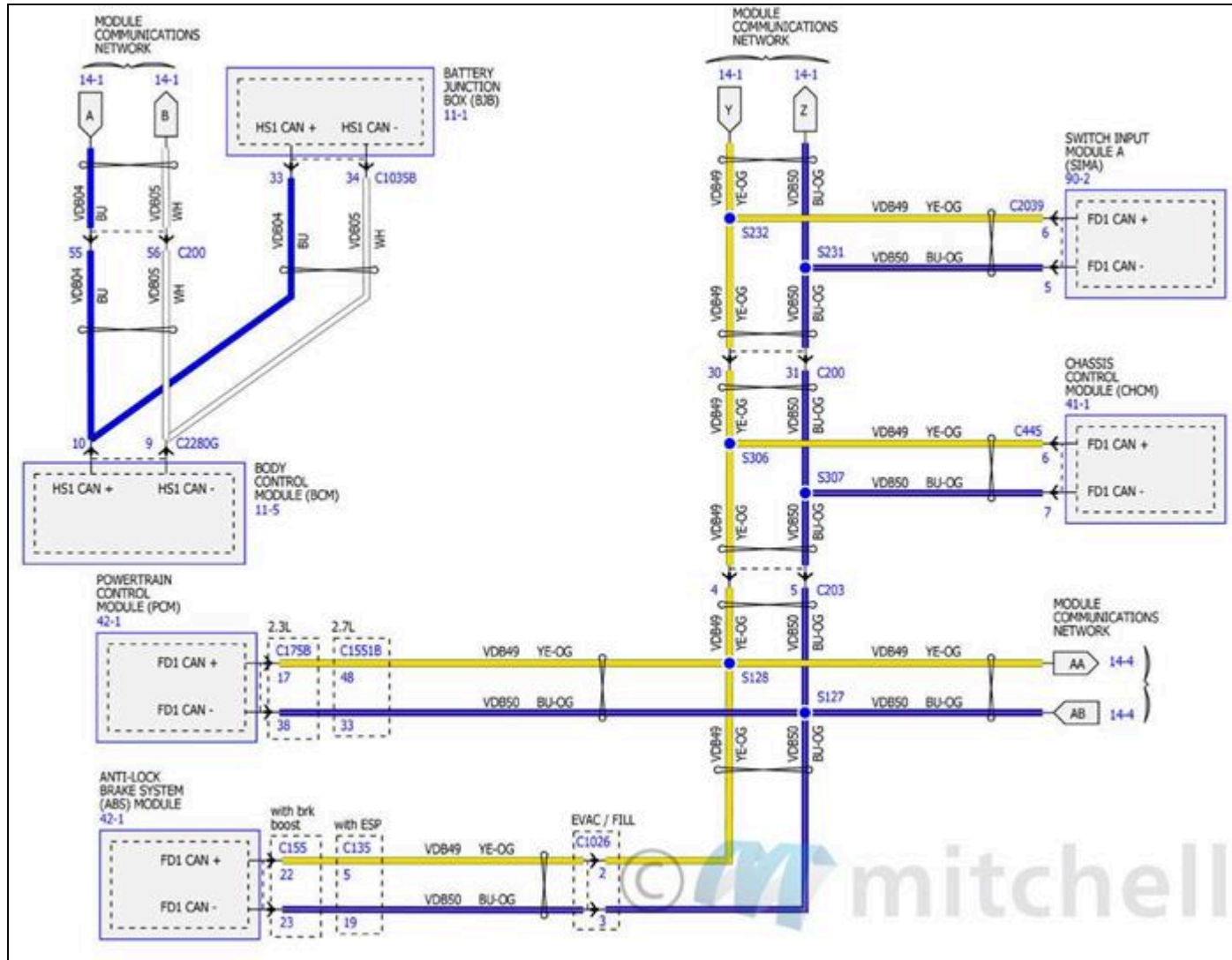

Fig. 110: Module Communications Network Wiring Diagrams (4 Of 8)

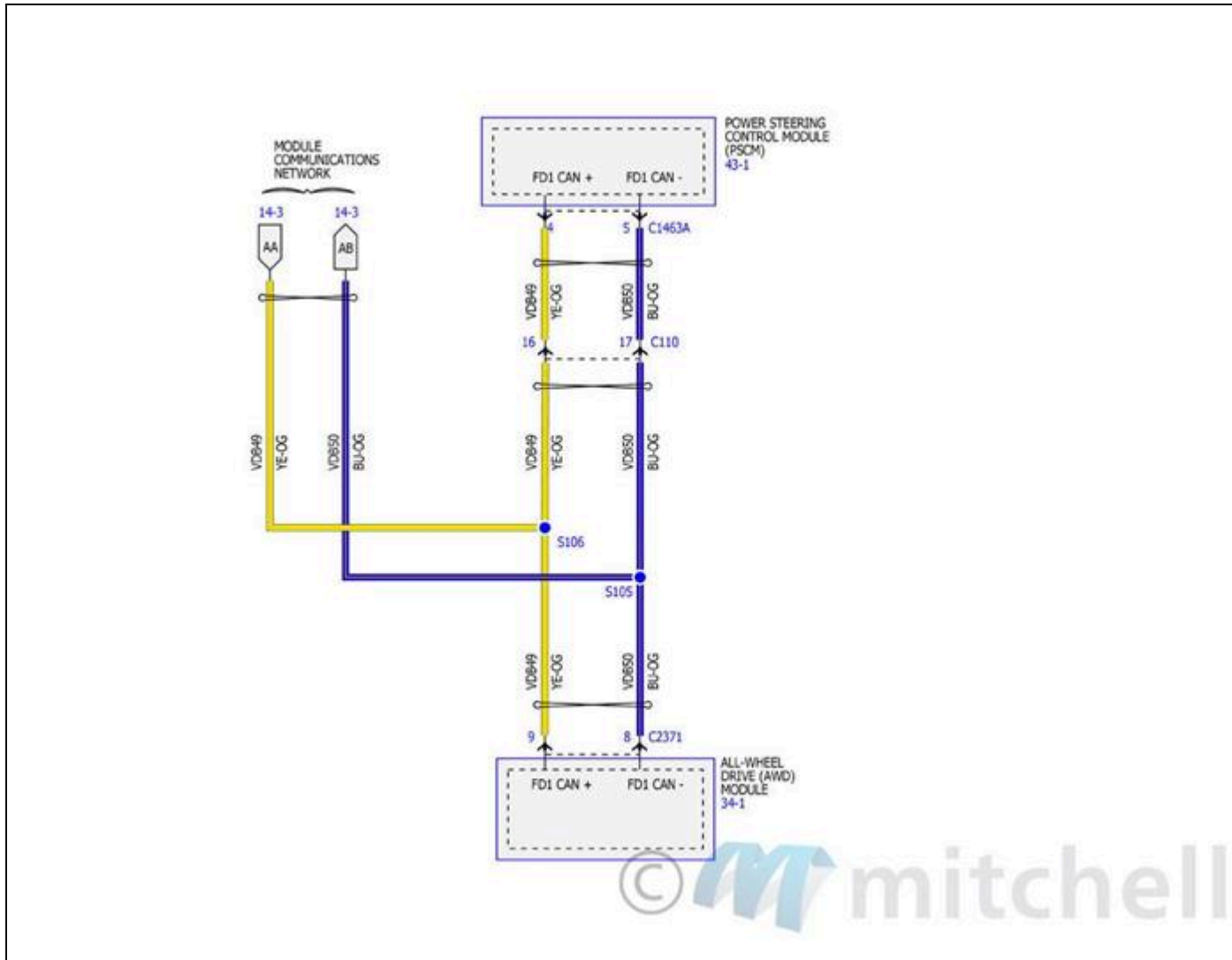

Fig. 111: Module Communications Network Wiring Diagrams (5 Of 8)

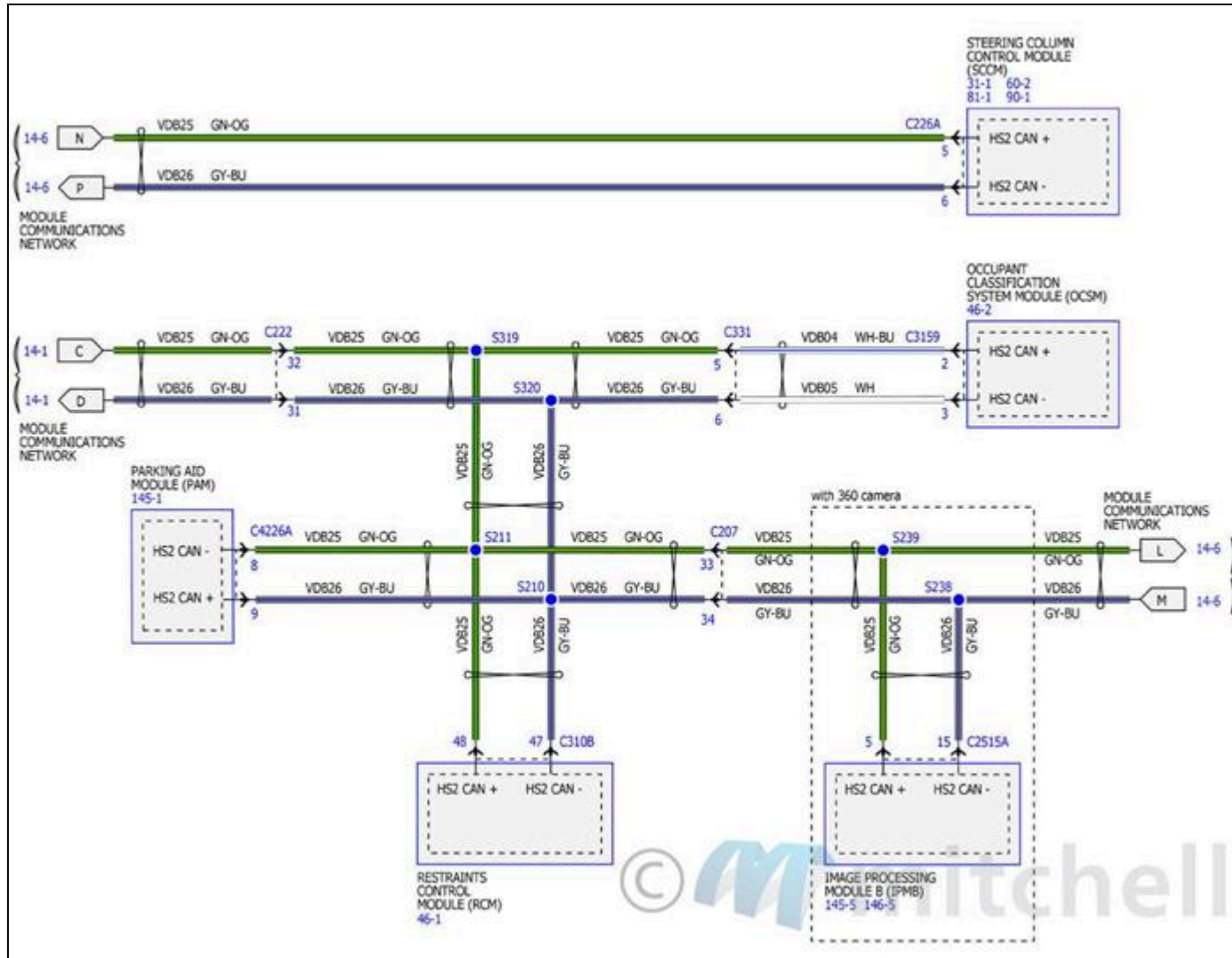

Fig. 112: Module Communications Network Wiring Diagrams (6 Of 8)

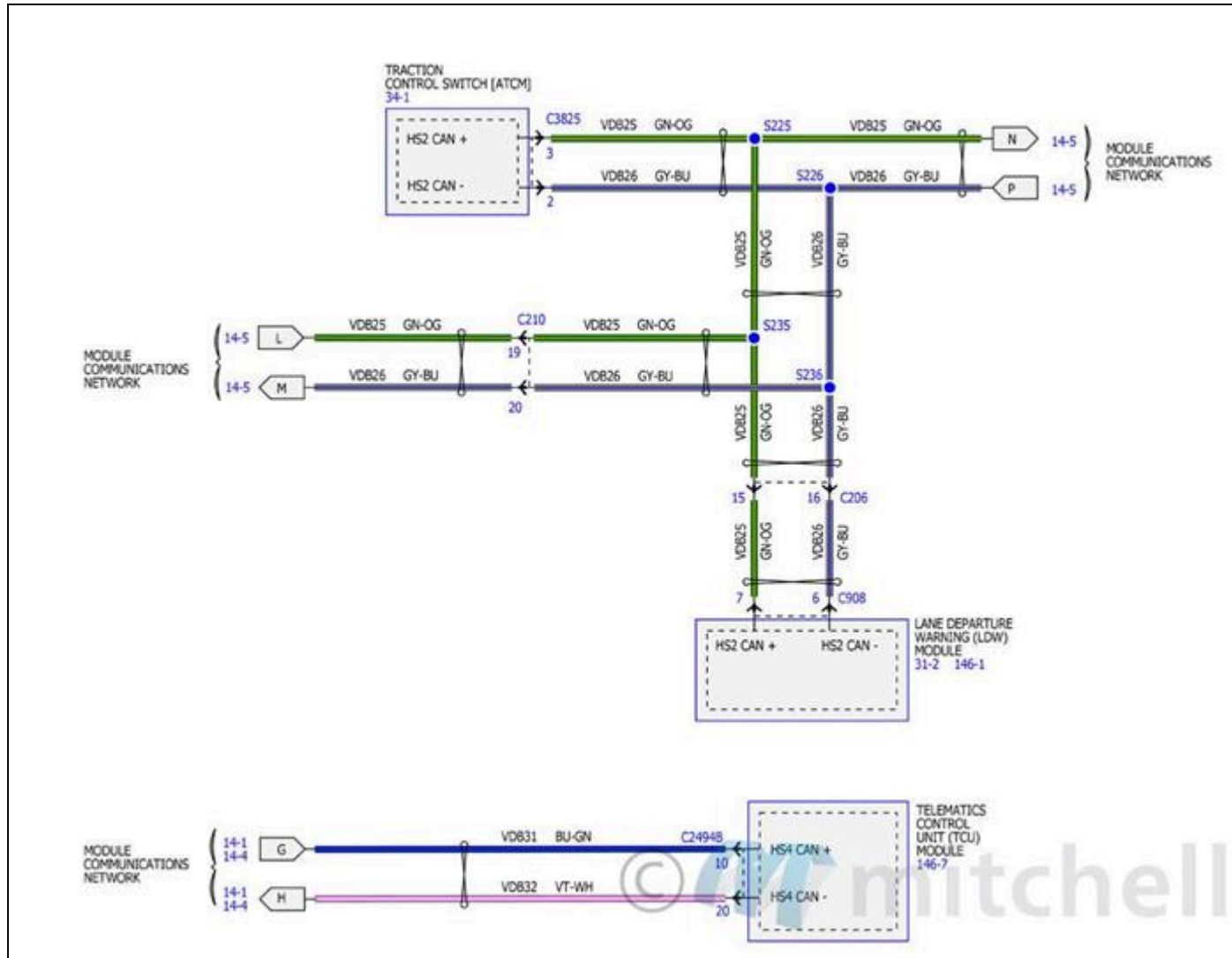

Fig. 113: Module Communications Network Wiring Diagrams (7 Of 8)

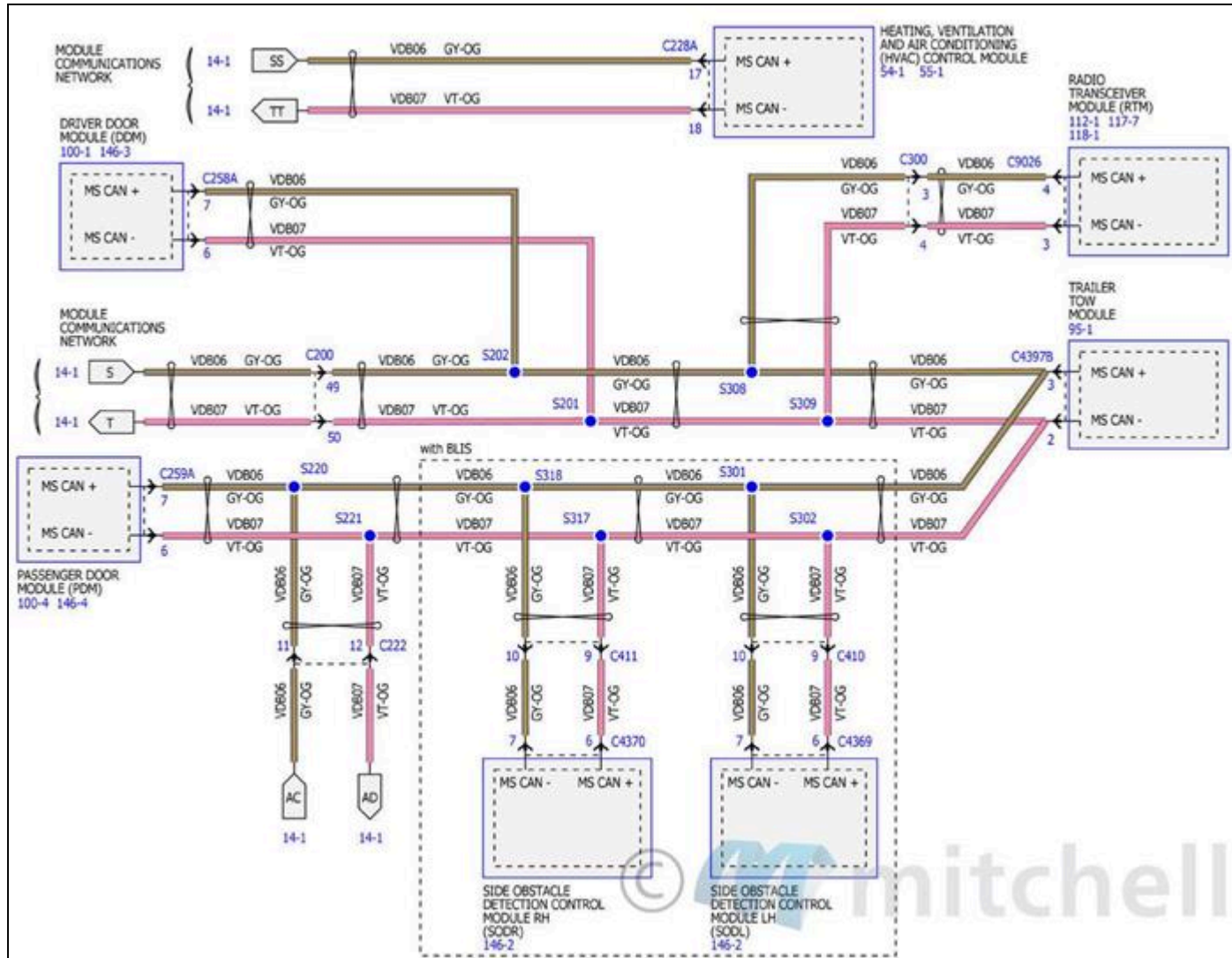
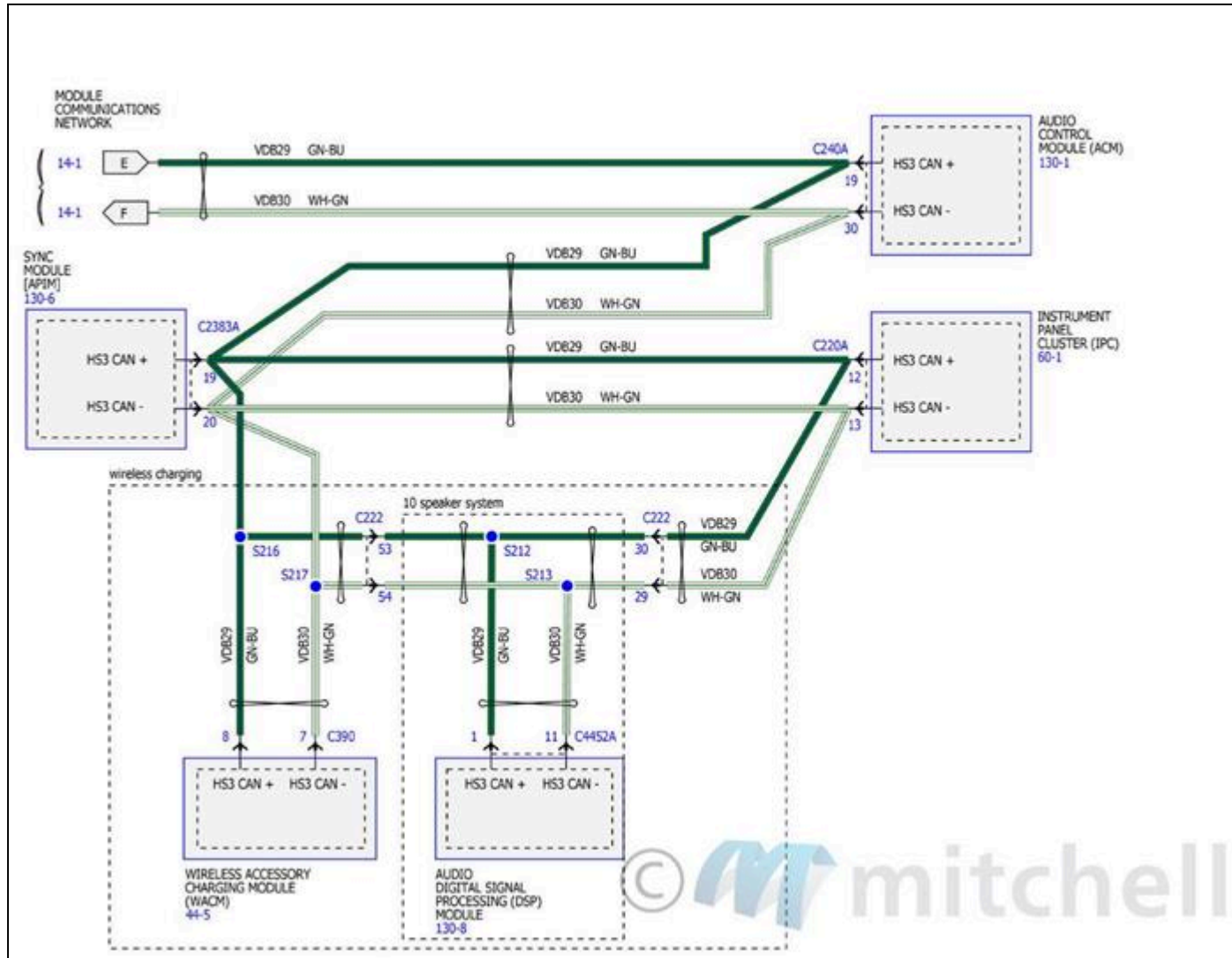

Fig. 114: Module Communications Network Wiring Diagrams (8 Of 8)



PARKING AID

Fig. 115: Parking Aid Wiring Diagrams (1 Of 6)

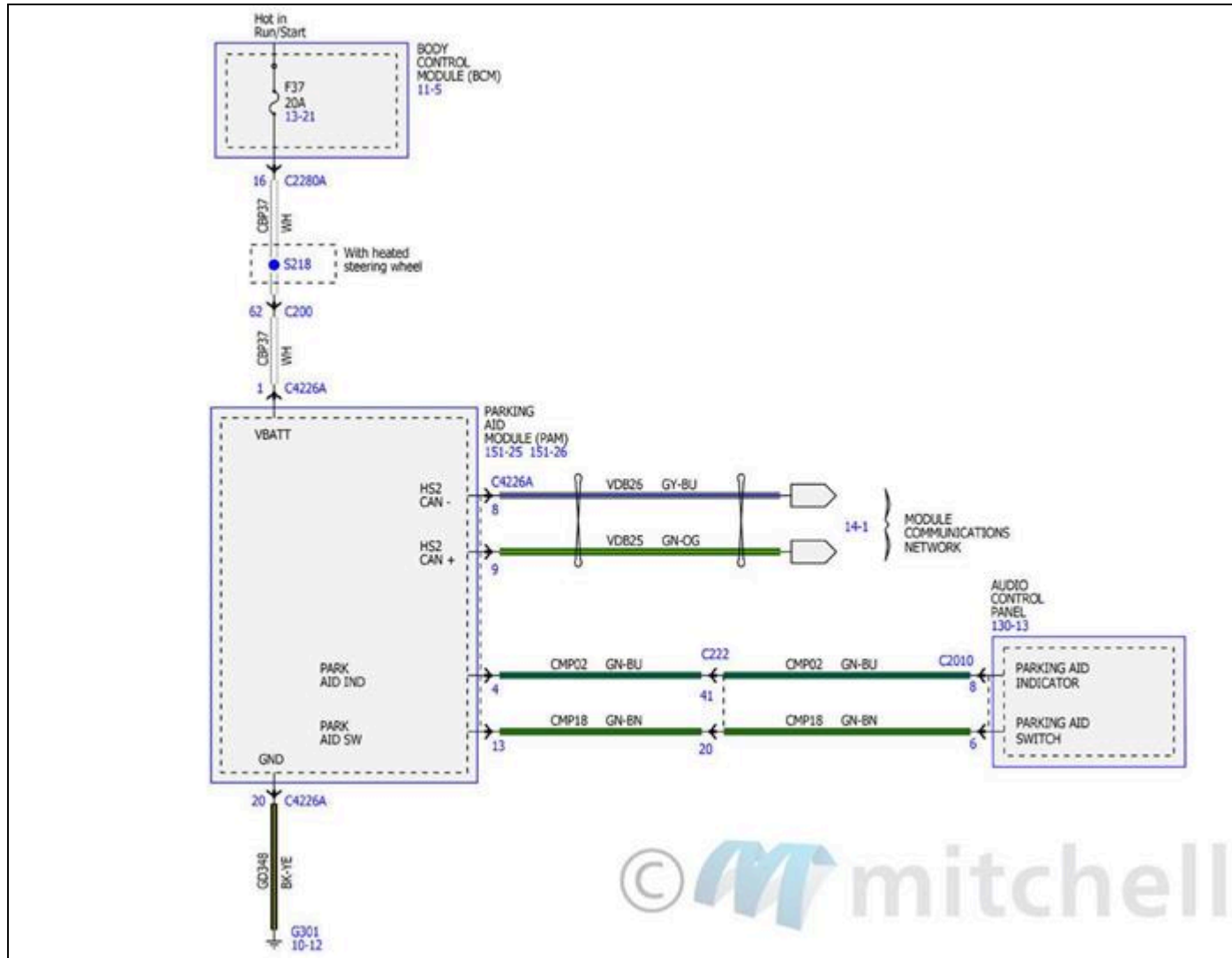

Fig. 116: Parking Aid Wiring Diagrams (2 Of 6)

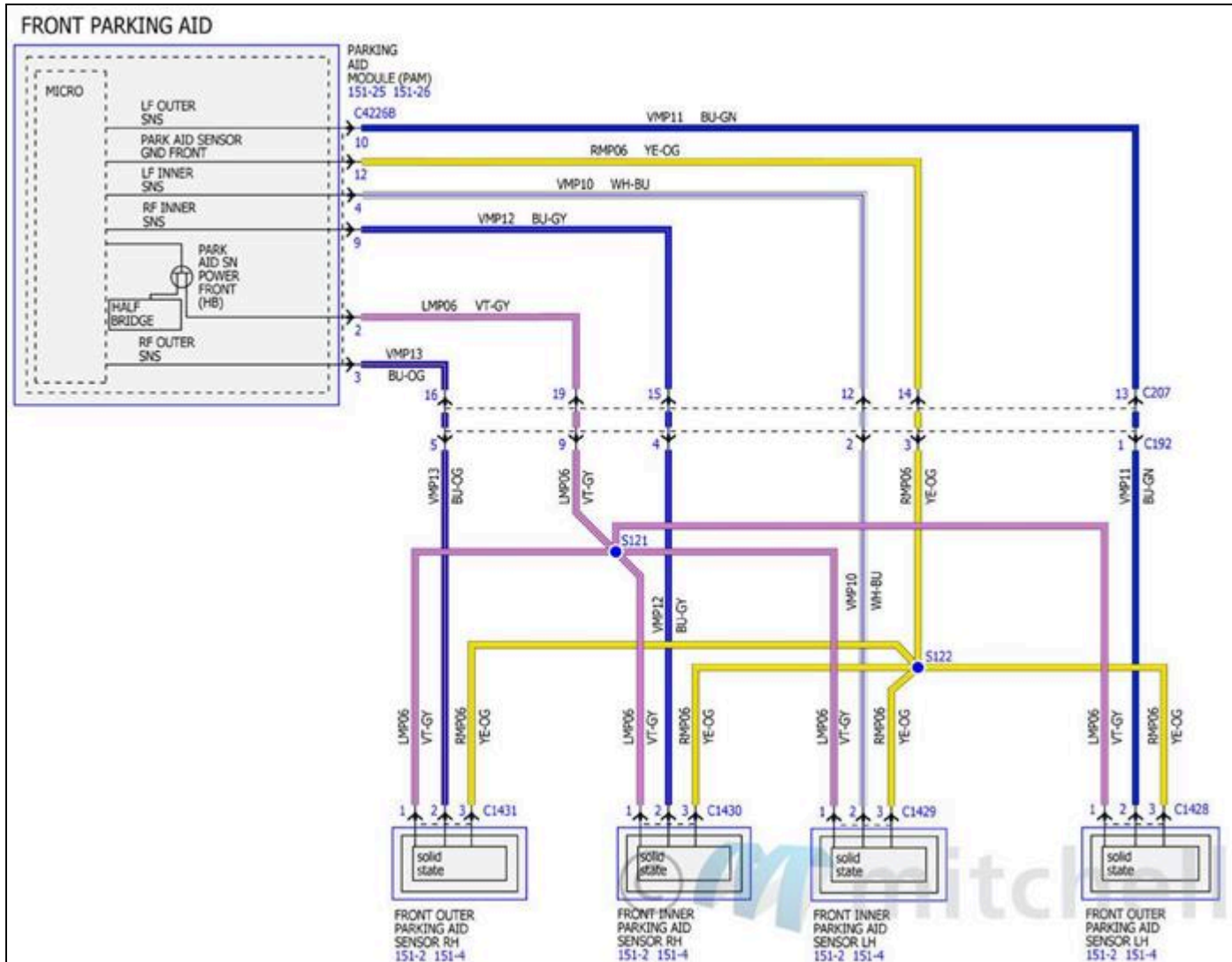

Fig. 117: Parking Aid Wiring Diagrams (3 Of 6)

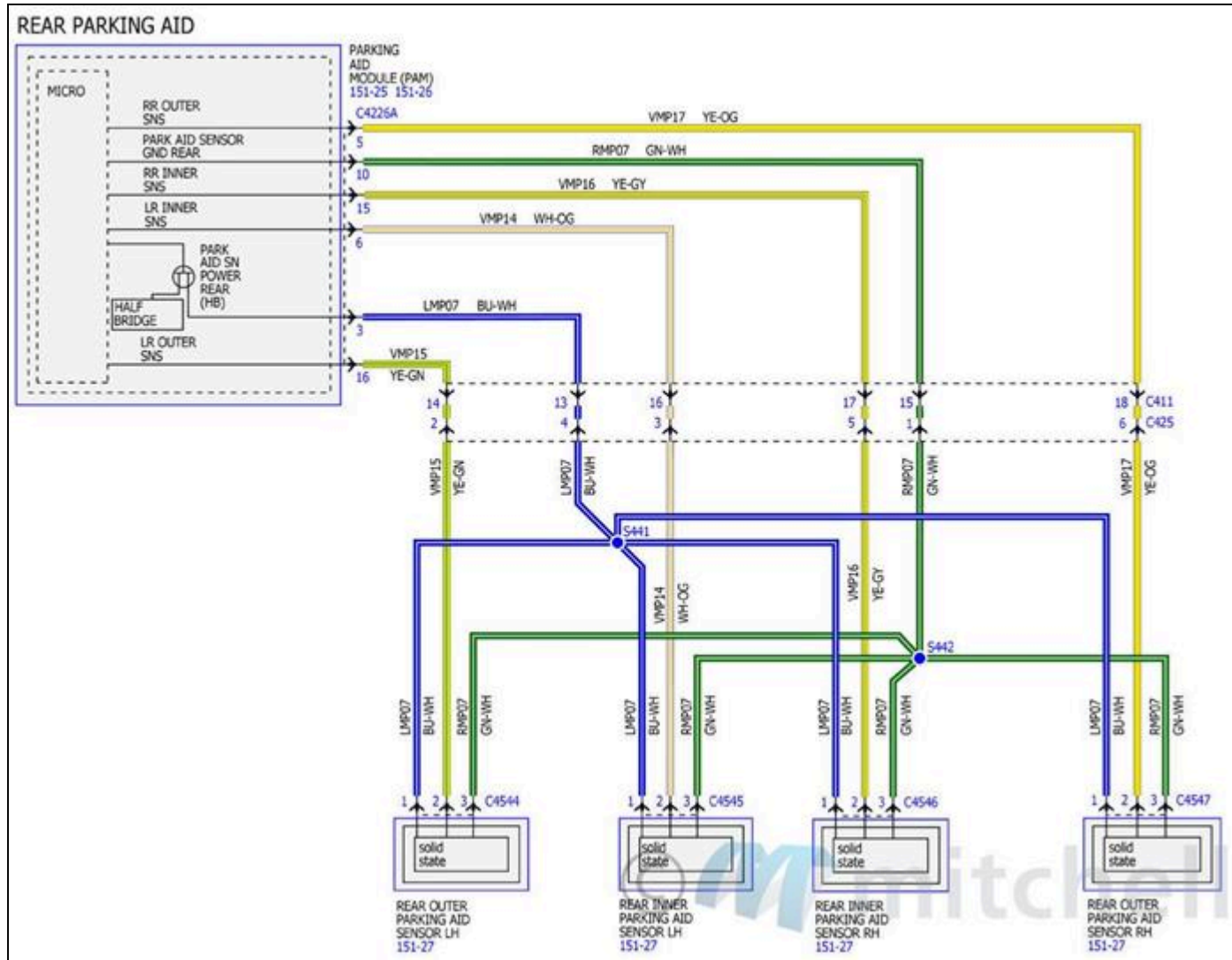

Fig. 118: Parking Aid Wiring Diagrams (4 Of 6)

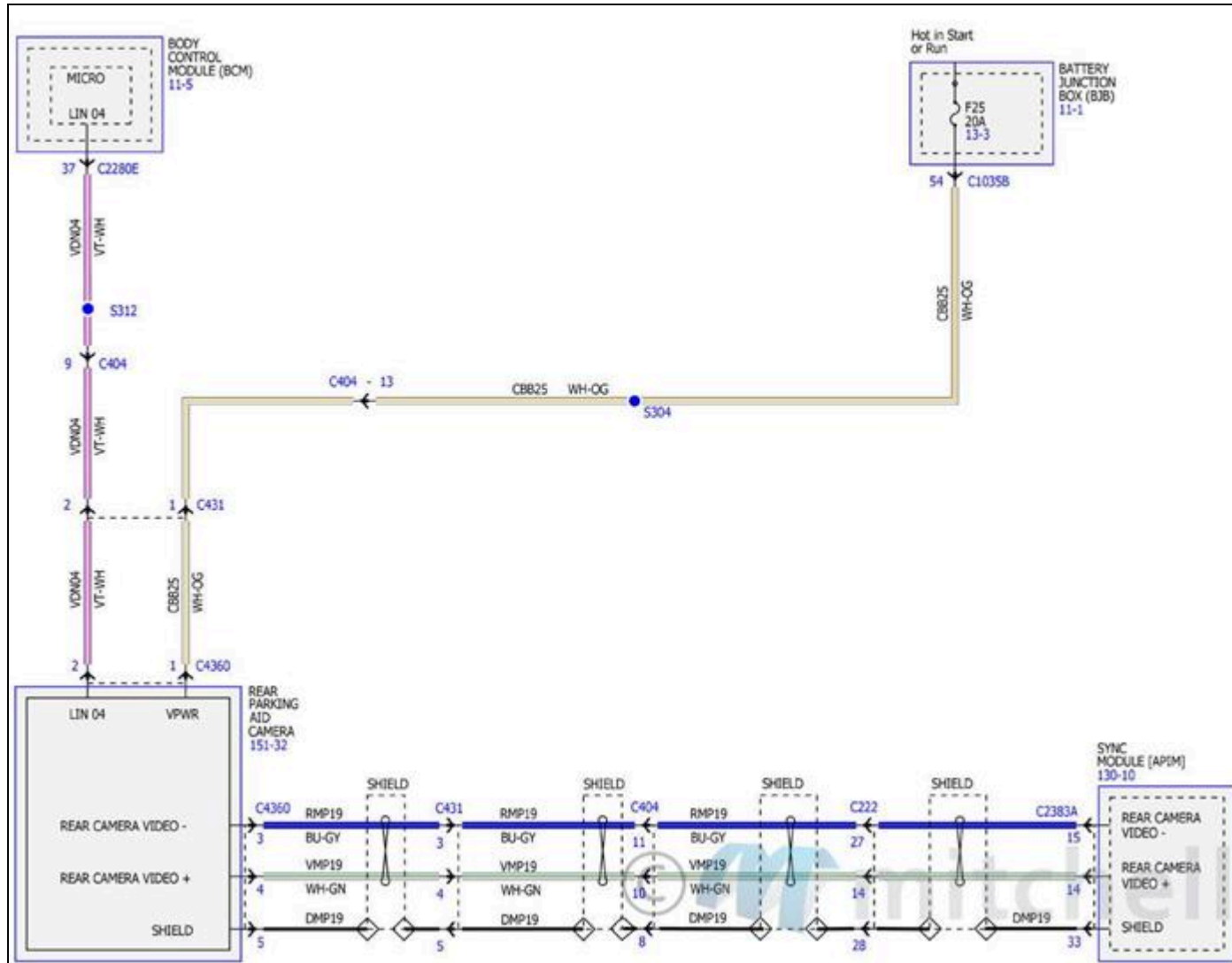

Fig. 119: Parking Aid Wiring Diagrams (5 Of 6)

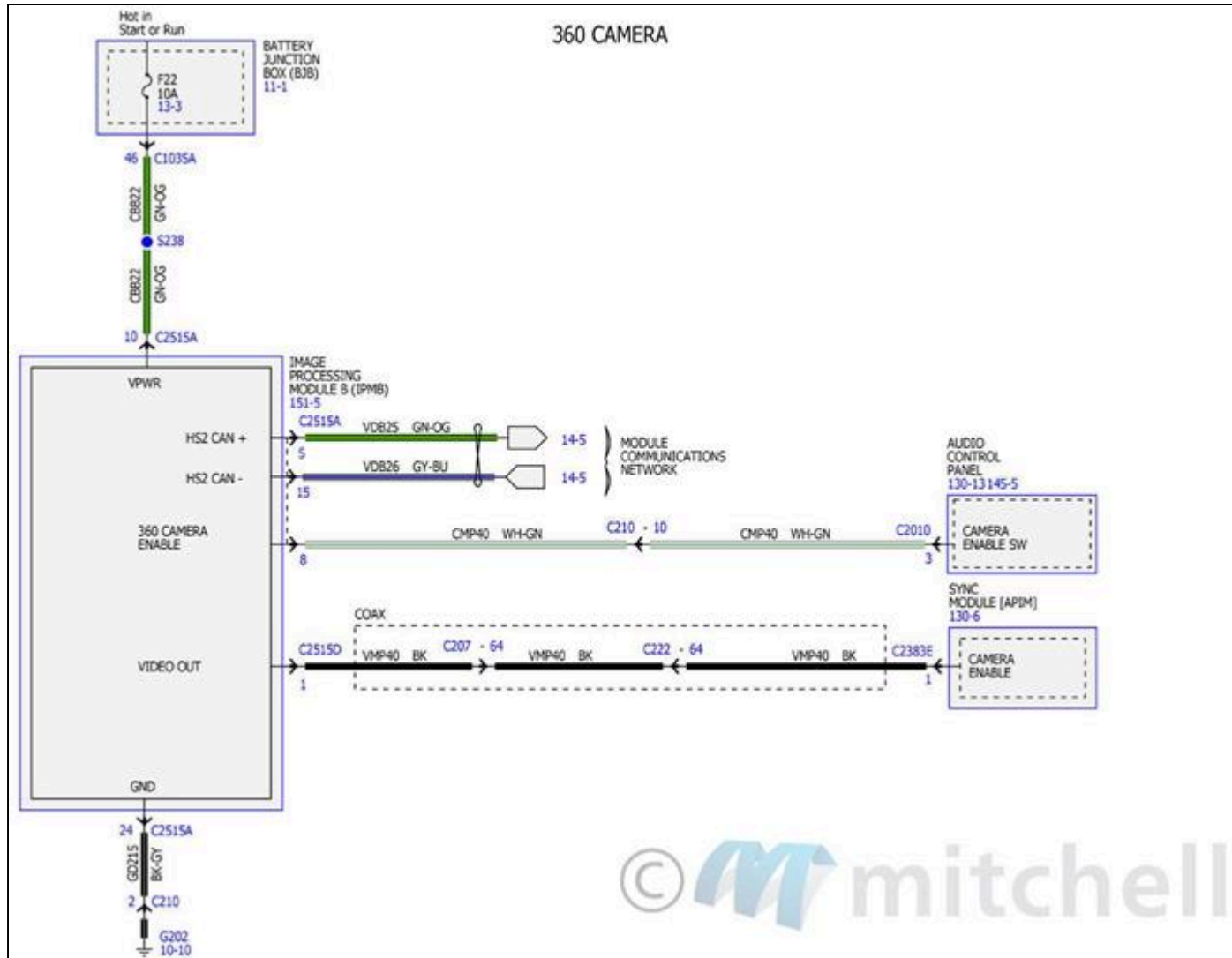
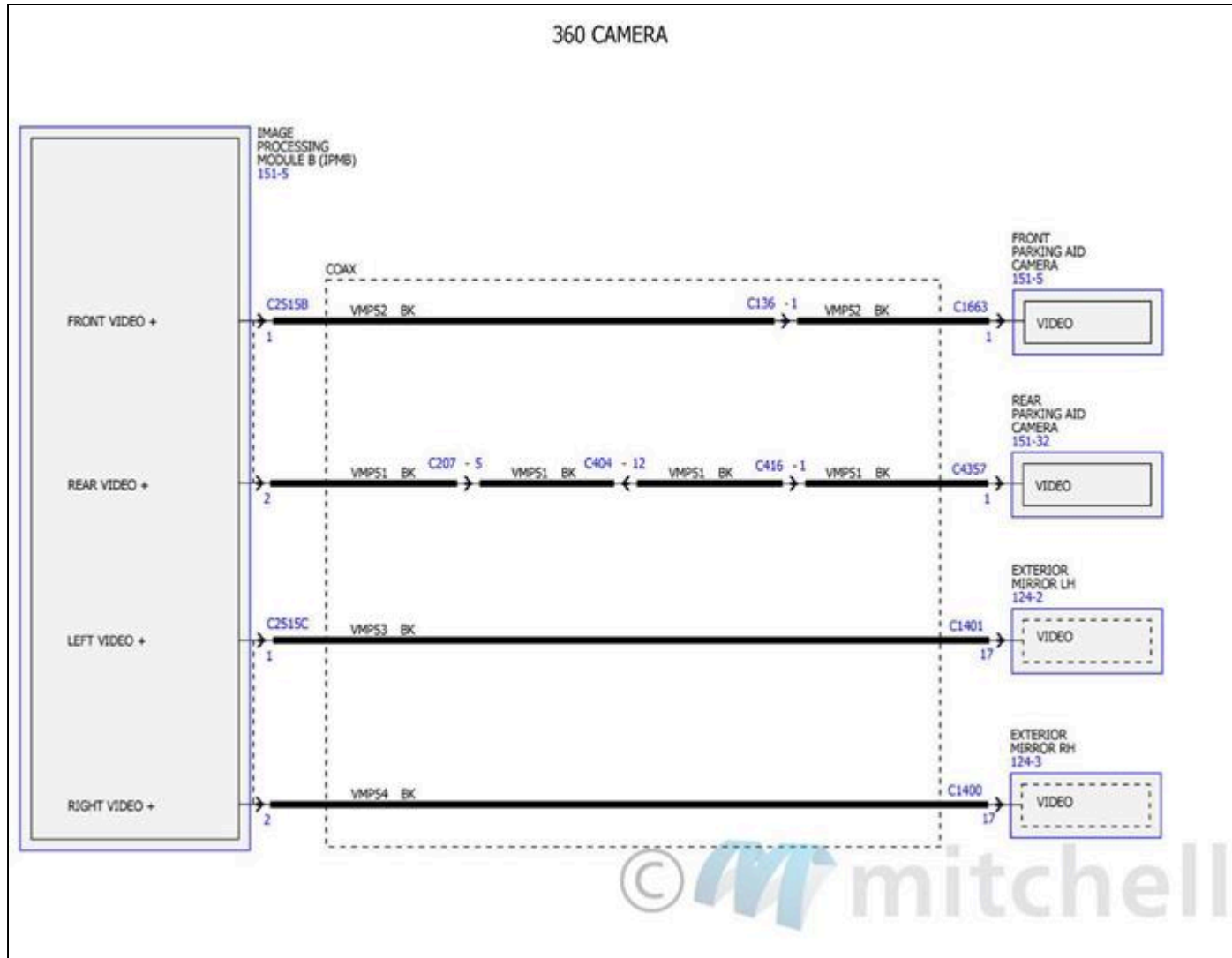

Fig. 120: Parking Aid Wiring Diagrams (6 Of 6)



PARKING, REAR AND LICENSE LAMPS

Fig. 121: Parking, Rear and License Lamps Wiring Diagrams (1 Of 6)

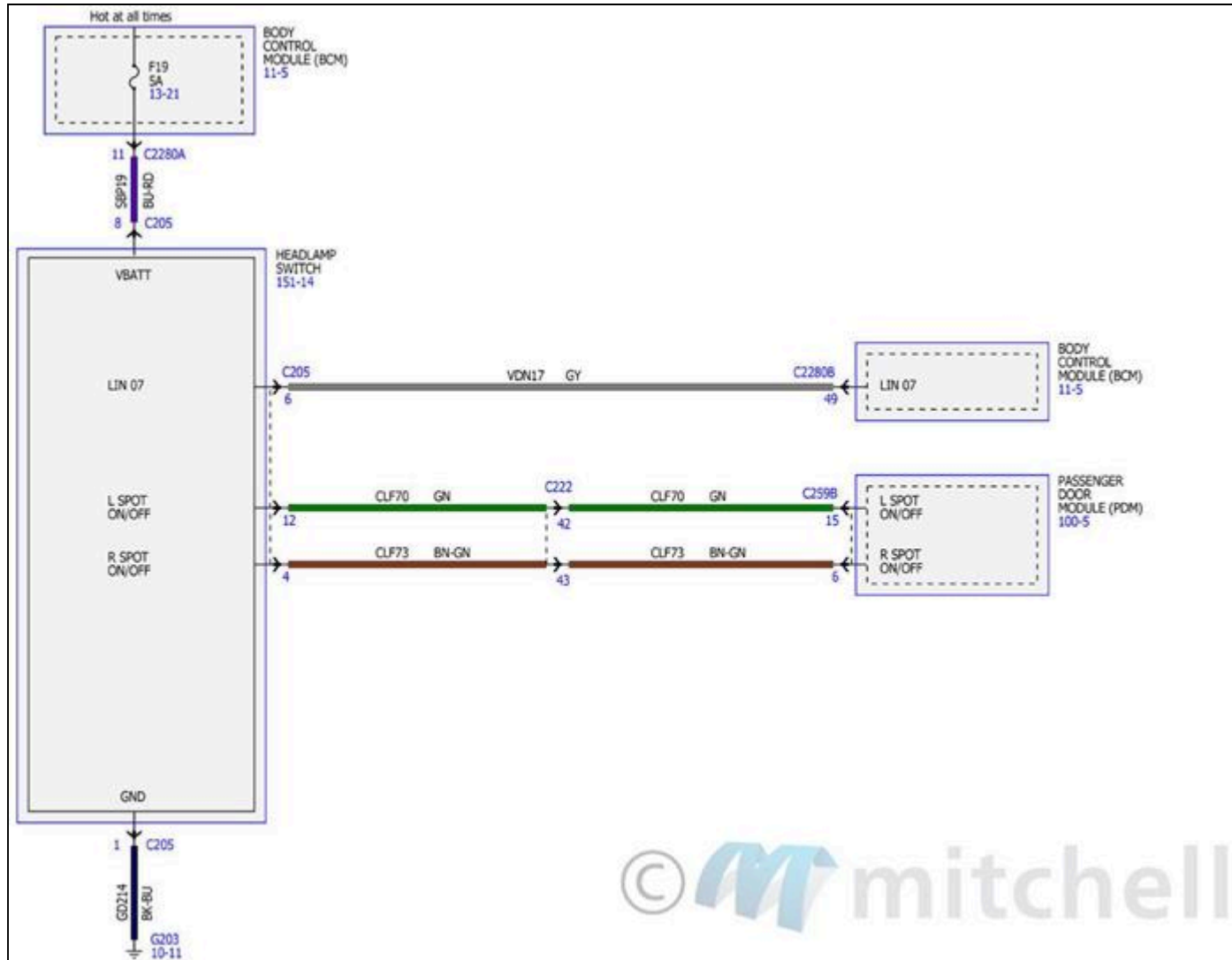

Fig. 122: Parking, Rear and License Lamps Wiring Diagrams (2 Of 6)

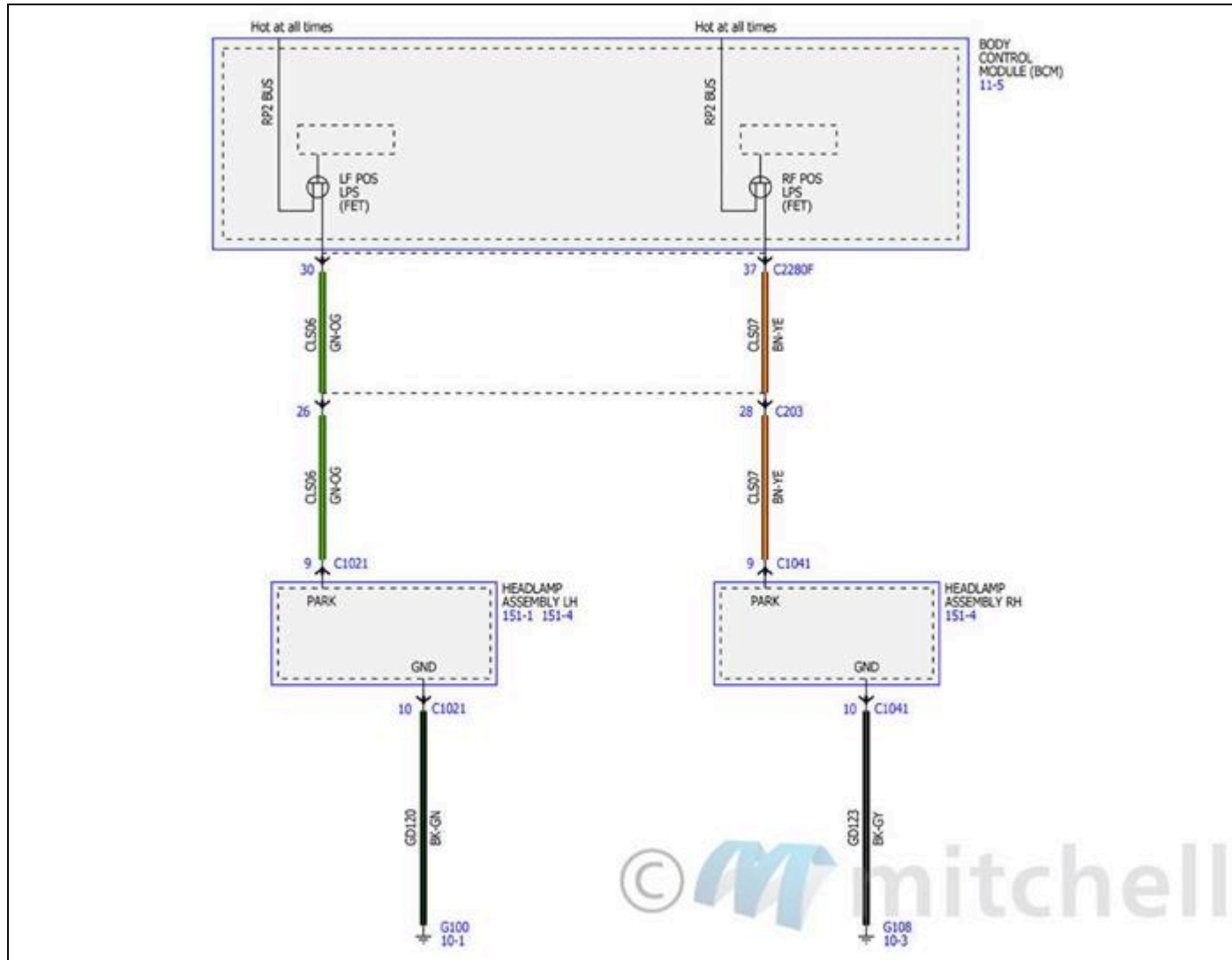

Fig. 123: Parking, Rear and License Lamps Wiring Diagrams (3 Of 6)

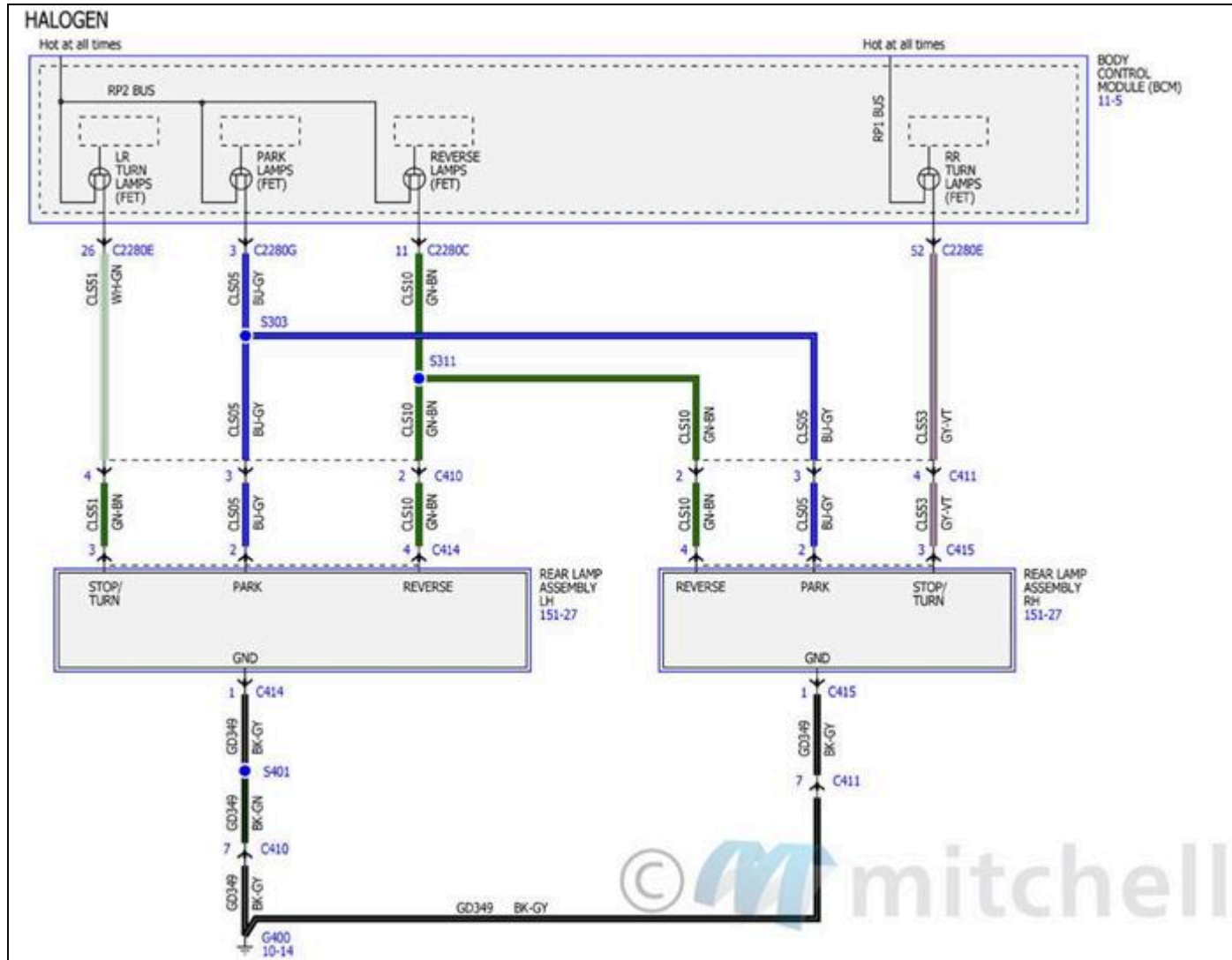

Fig. 124: Parking, Rear and License Lamps Wiring Diagrams (4 Of 6)

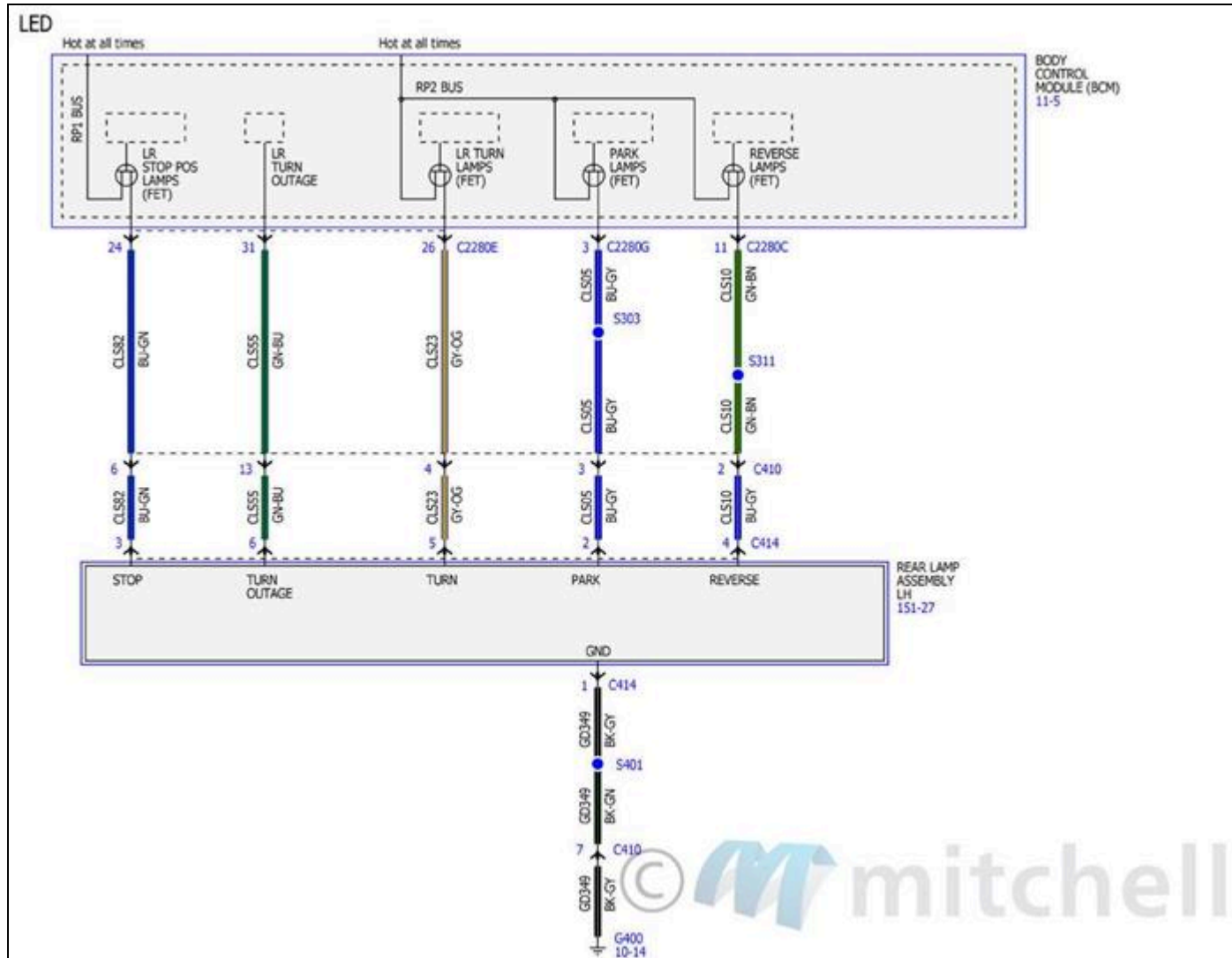

Fig. 125: Parking, Rear and License Lamps Wiring Diagrams (5 Of 6)

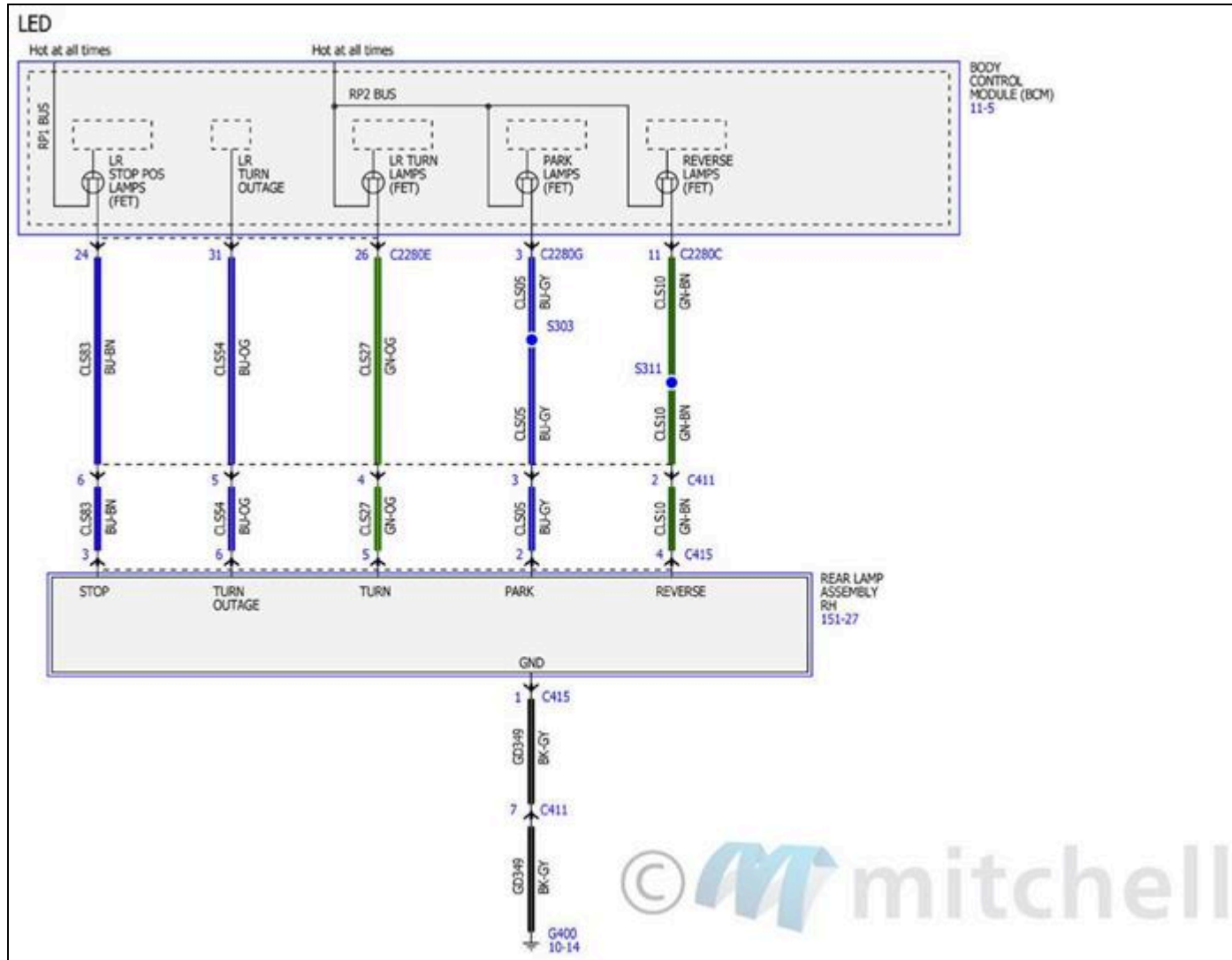
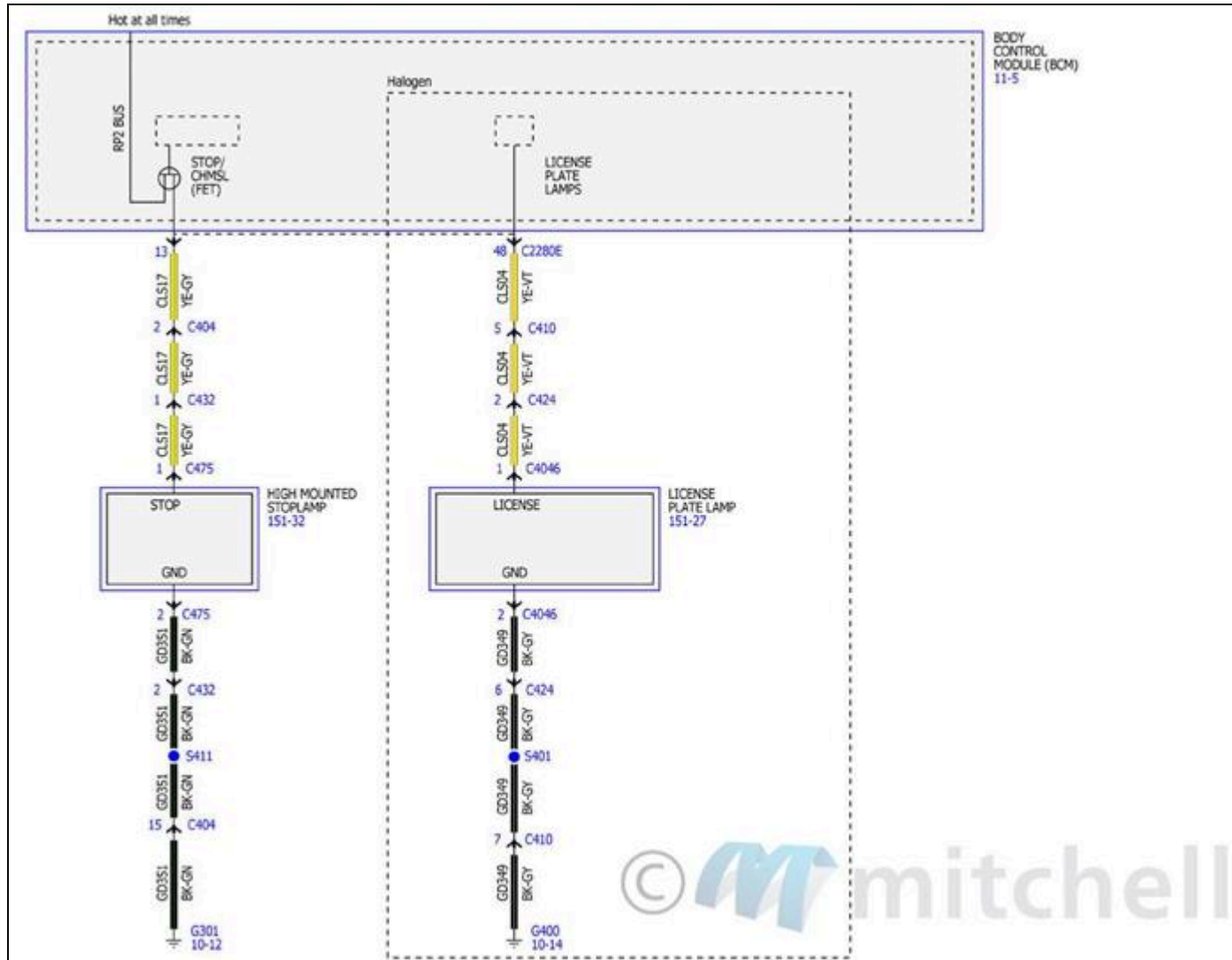

Fig. 126: Parking, Rear and License Lamps Wiring Diagrams (6 Of 6)



PASSIVE ANTI-THEFT SYSTEM

Fig. 128: Passive Anti-Theft System Wiring Diagrams (2 Of 3)

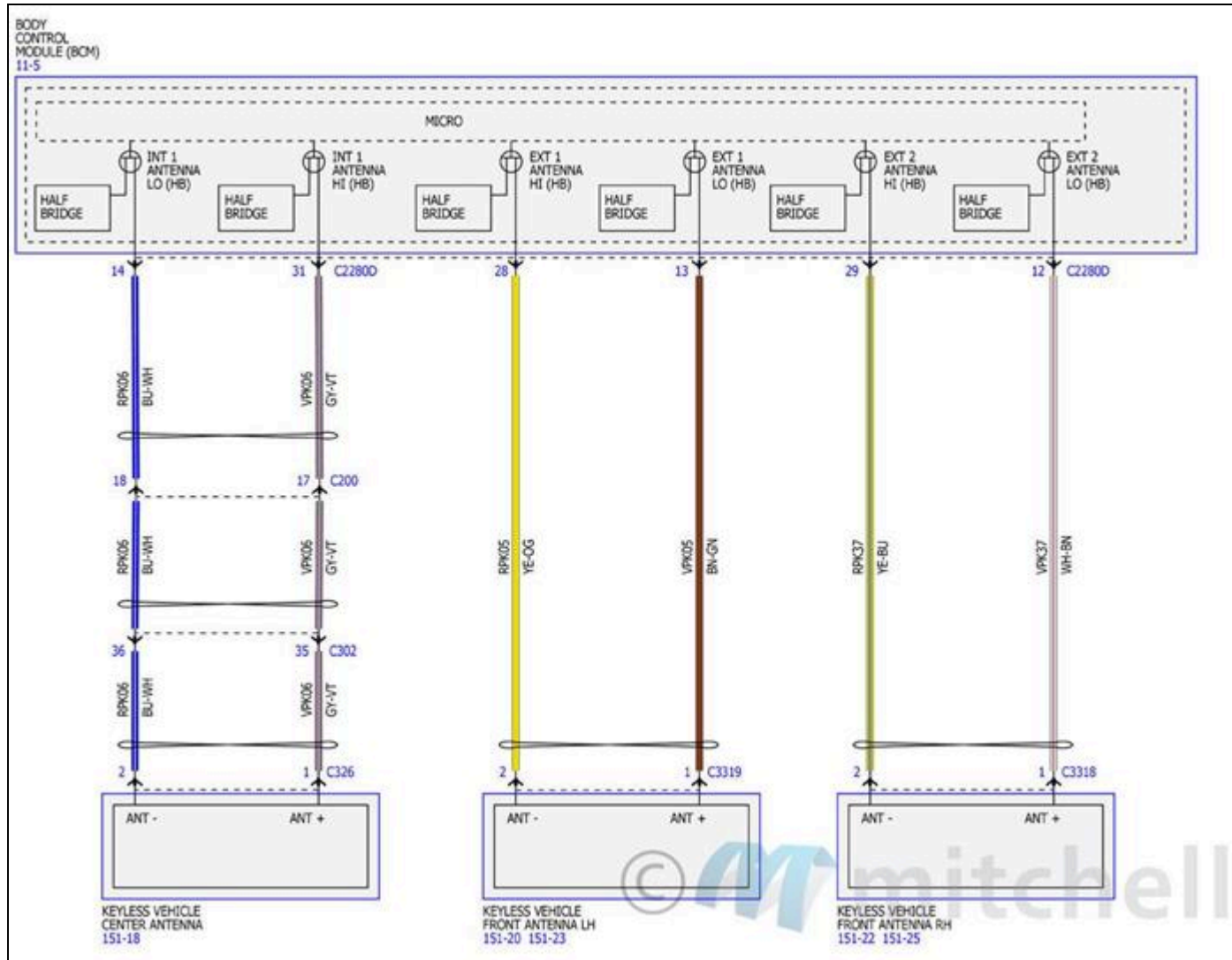
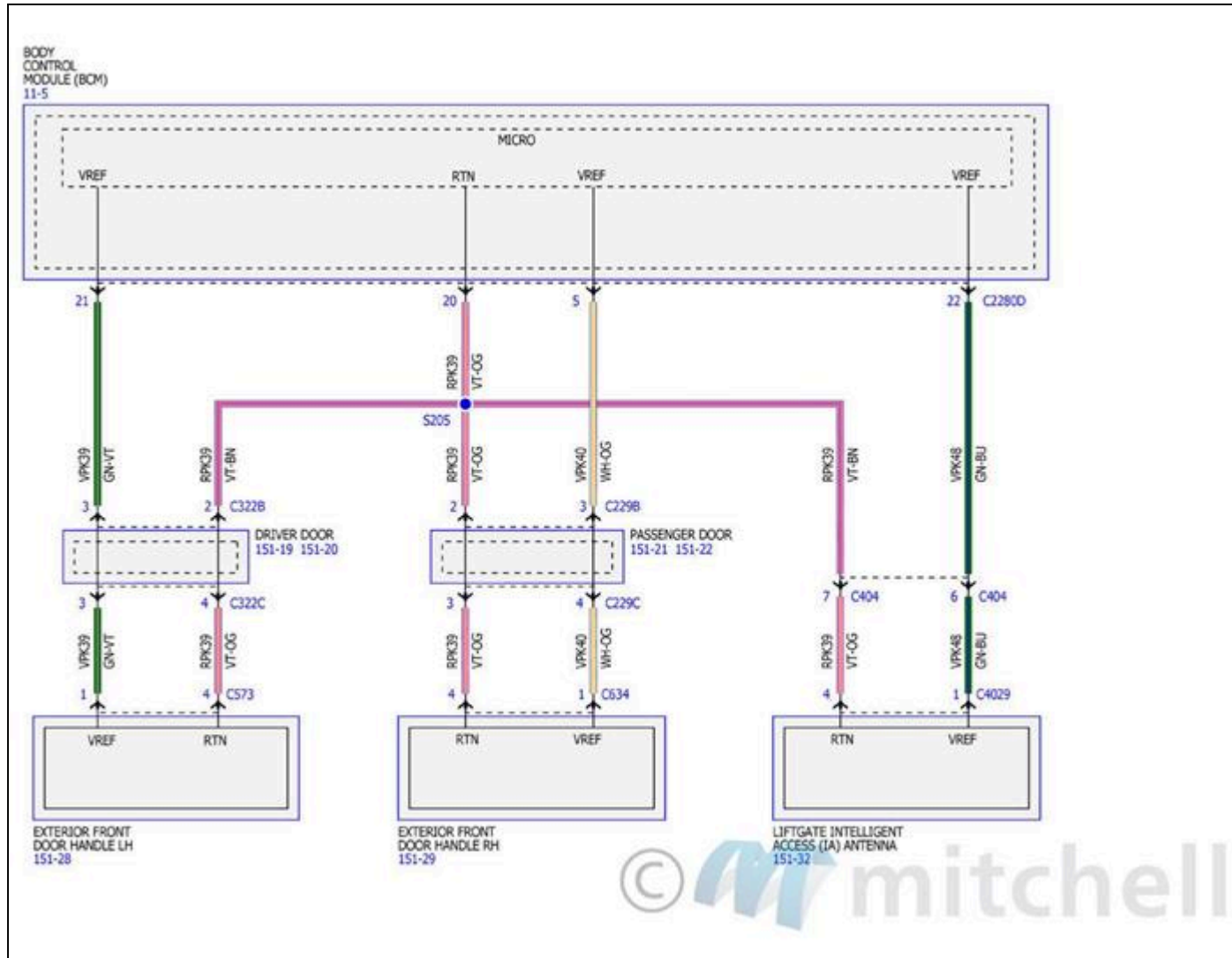

Fig. 129: Passive Anti-Theft System Wiring Diagrams (3 Of 3)



POWER DISTRIBUTION/BCM

Fig. 131: Power Distribution/BCM Wiring Diagrams (2 Of 34)

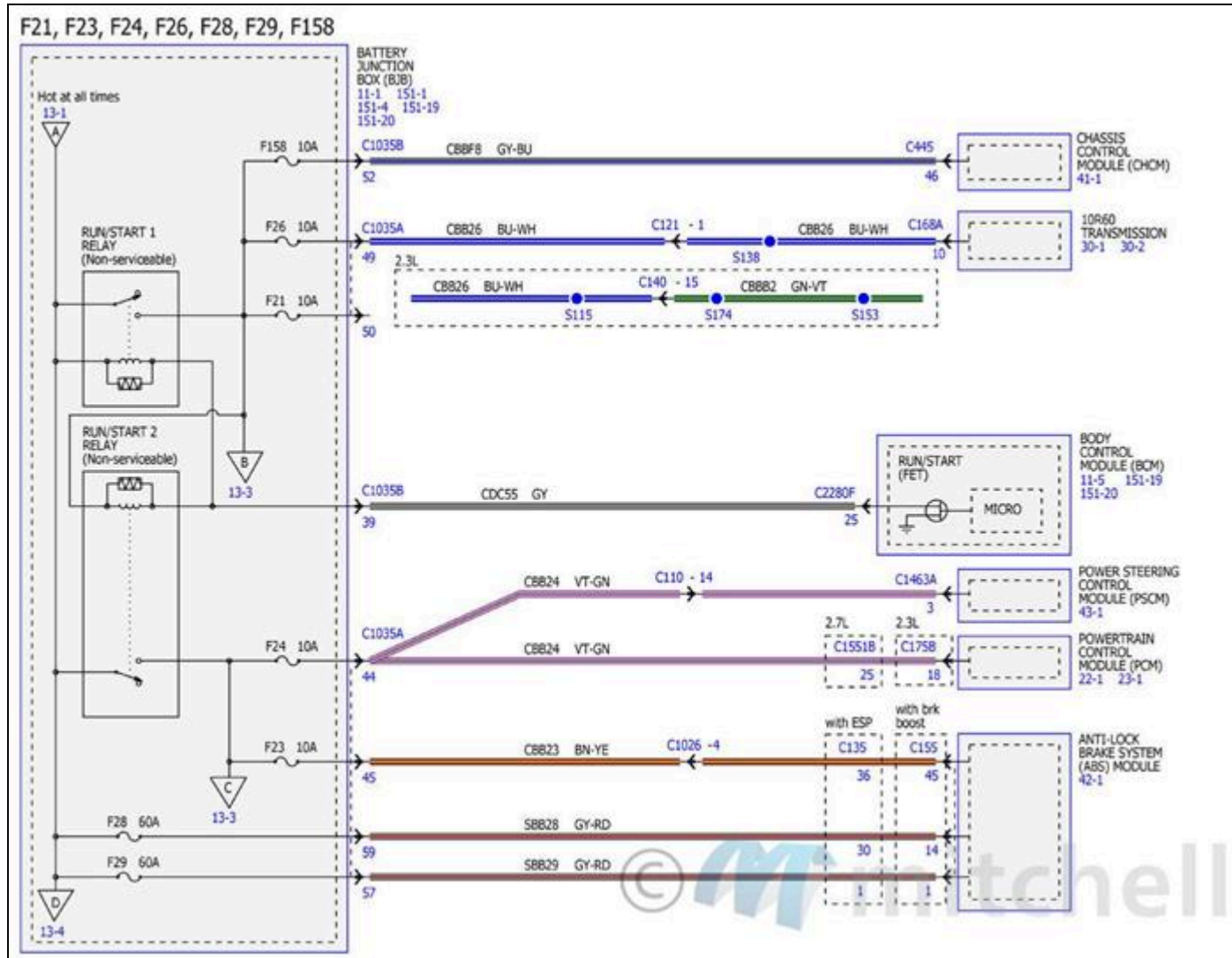

Fig. 132: Power Distribution/BCM Wiring Diagrams (3 Of 34)

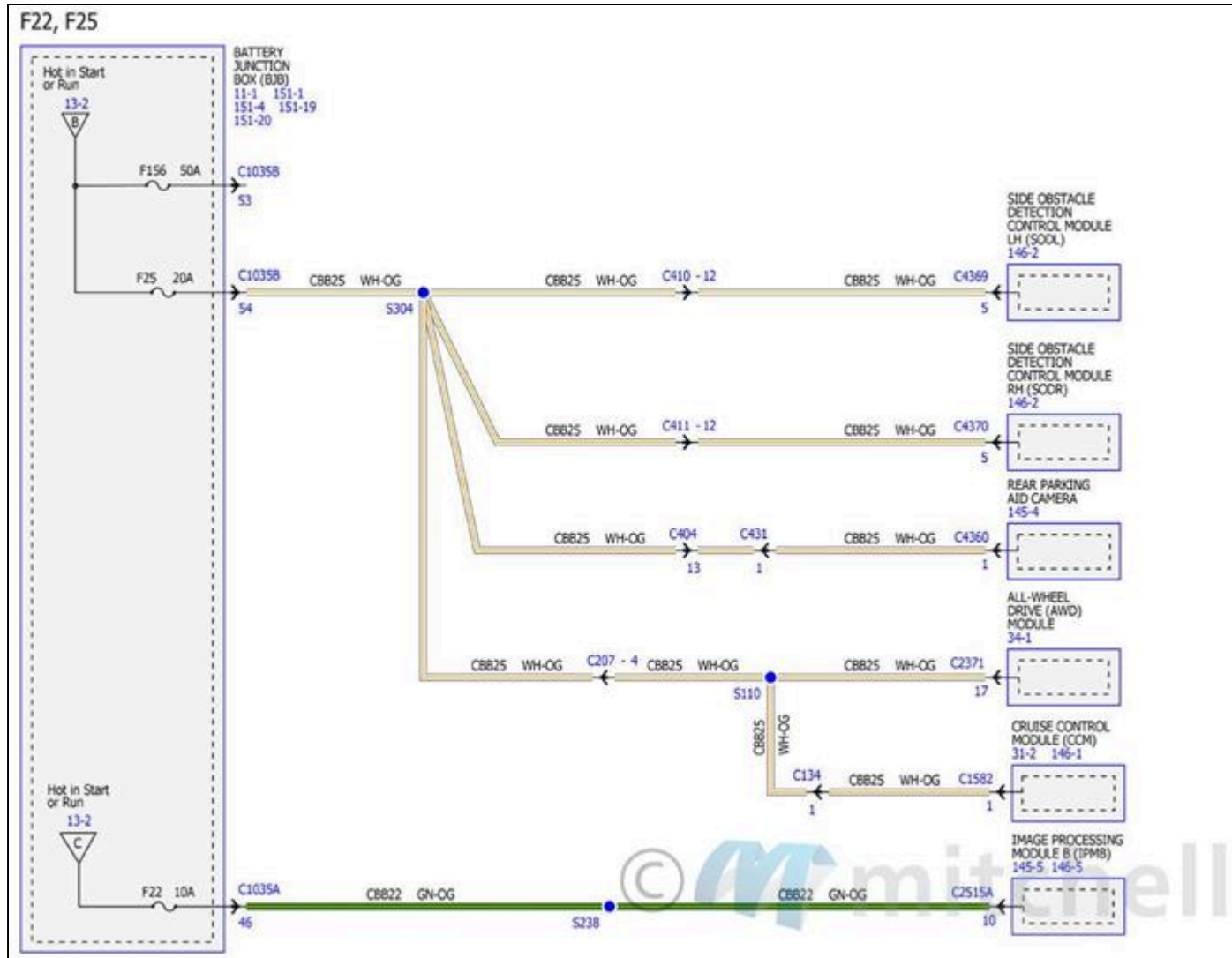

Fig. 133: Power Distribution/BCM Wiring Diagrams (4 Of 34)

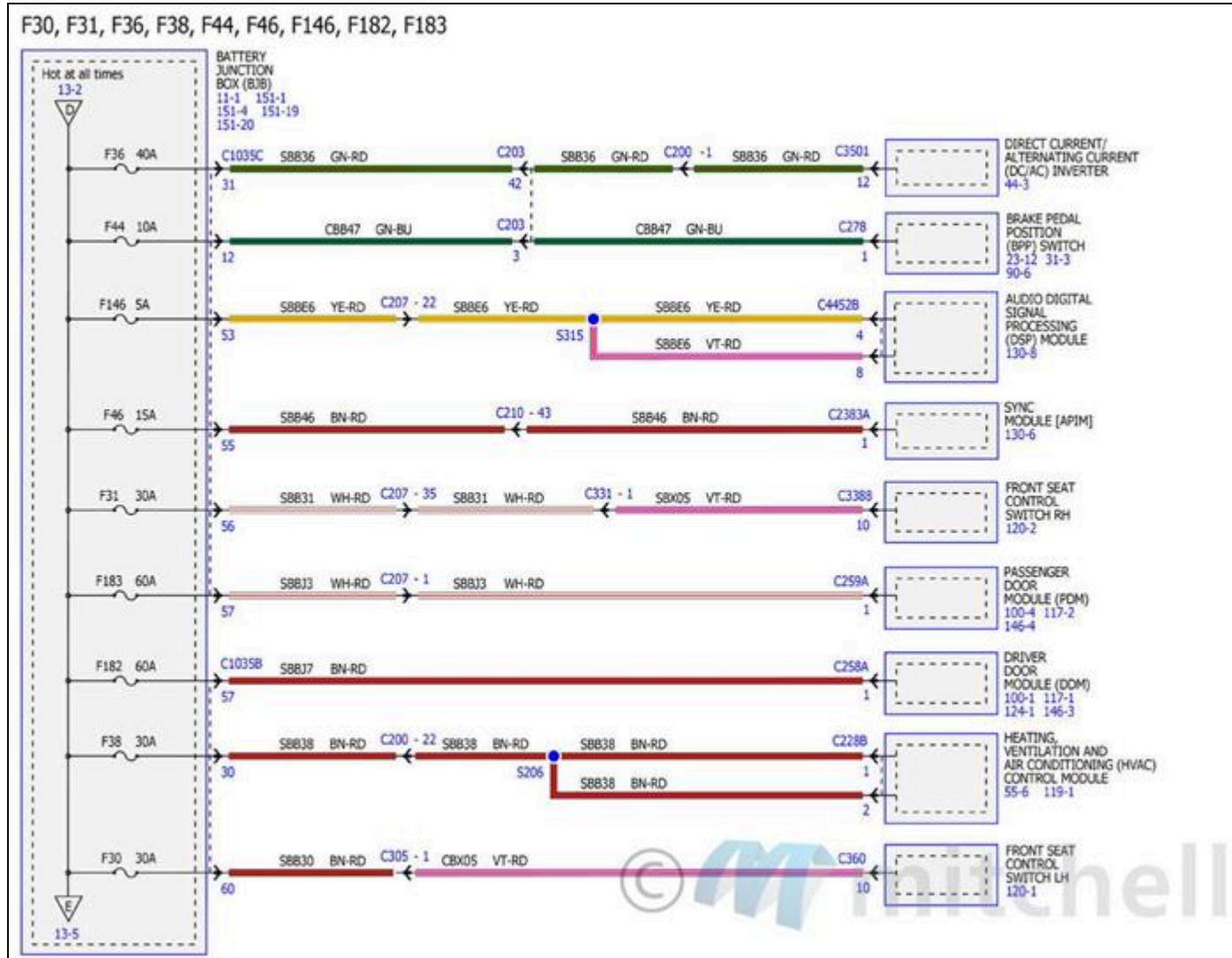

Fig. 134: Power Distribution/BCM Wiring Diagrams (5 Of 34)

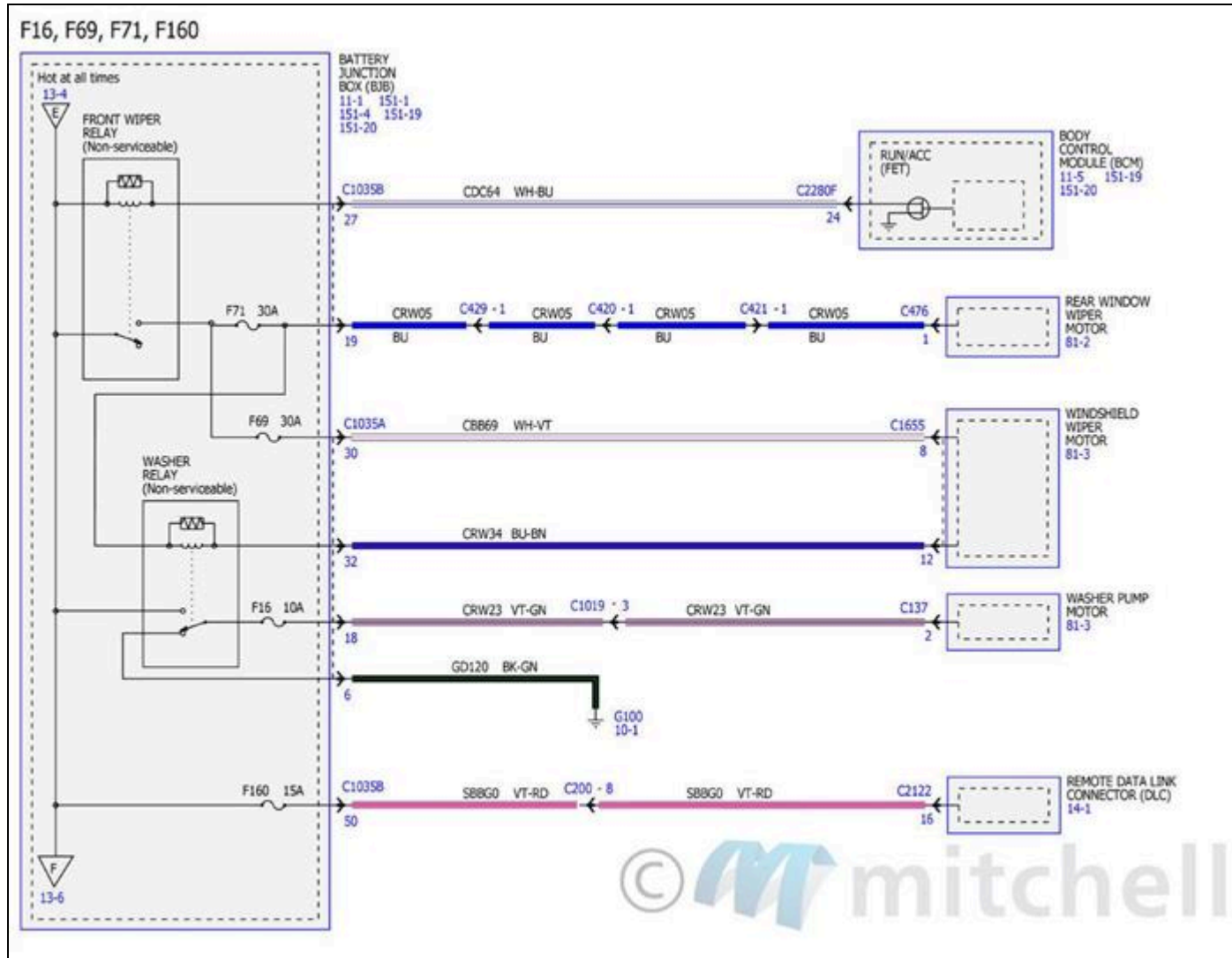

Fig. 135: Power Distribution/BCM Wiring Diagrams (6 Of 34)

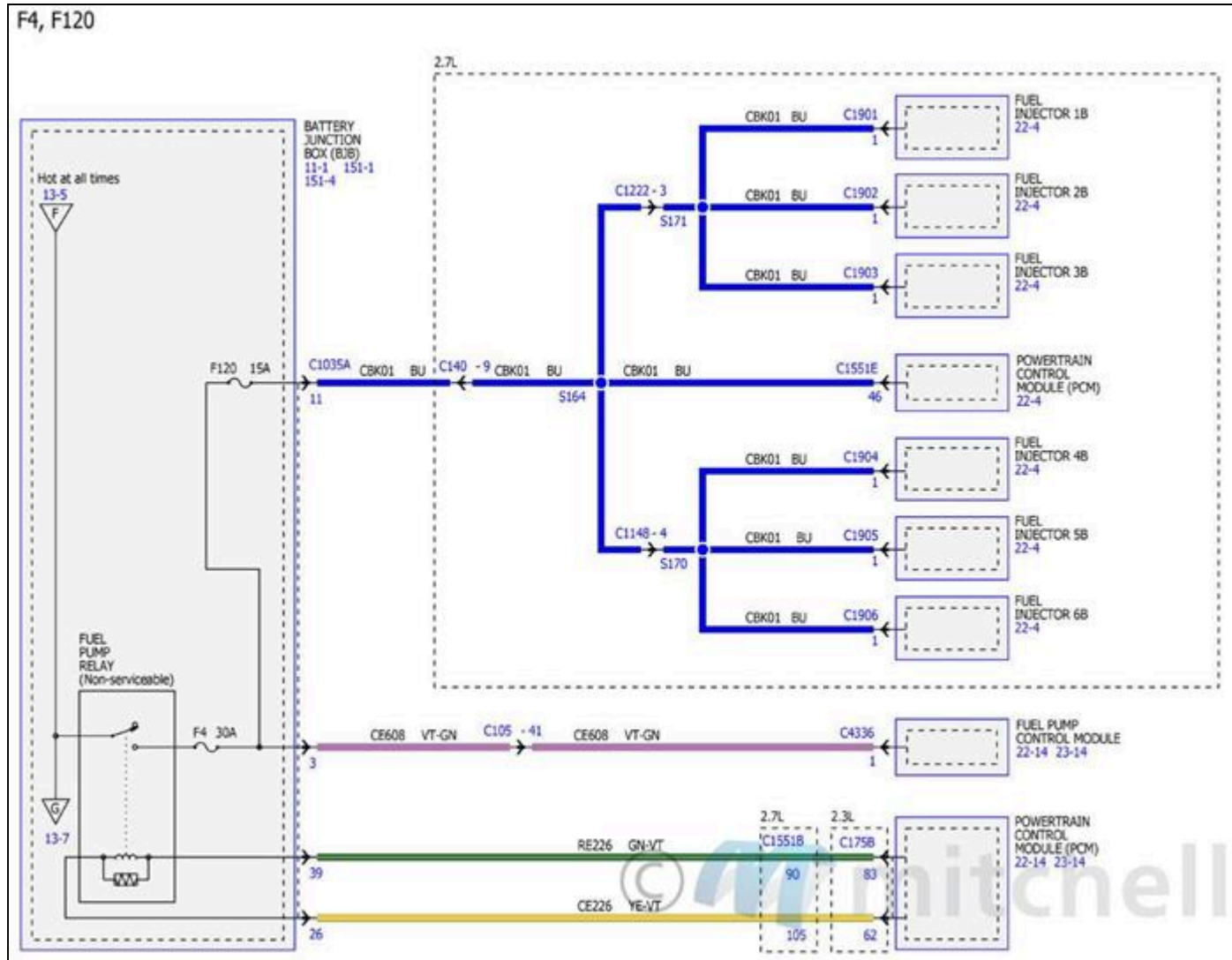

Fig. 136: Power Distribution/BCM Wiring Diagrams (7 Of 34)

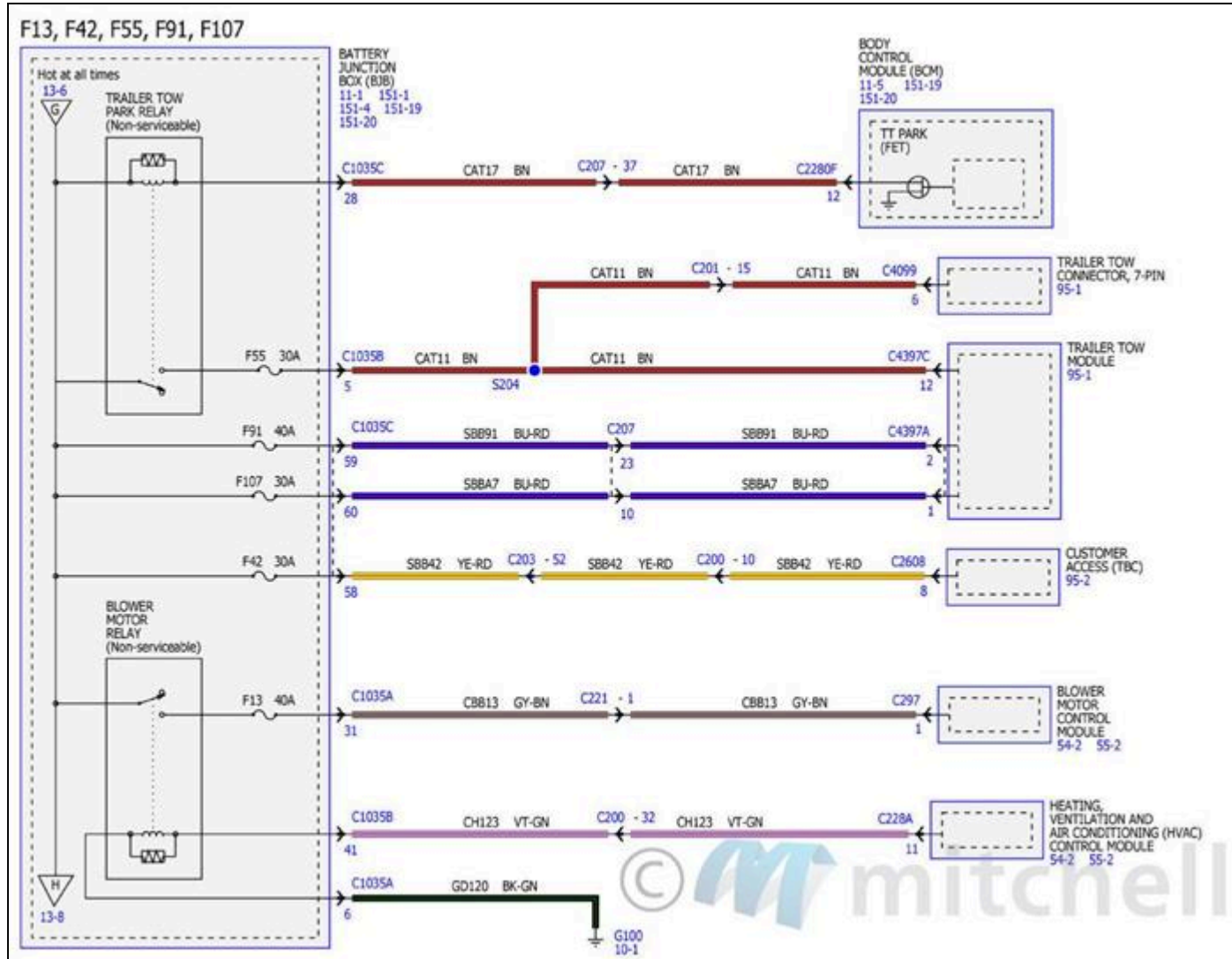

Fig. 137: Power Distribution/BCM Wiring Diagrams (8 Of 34)

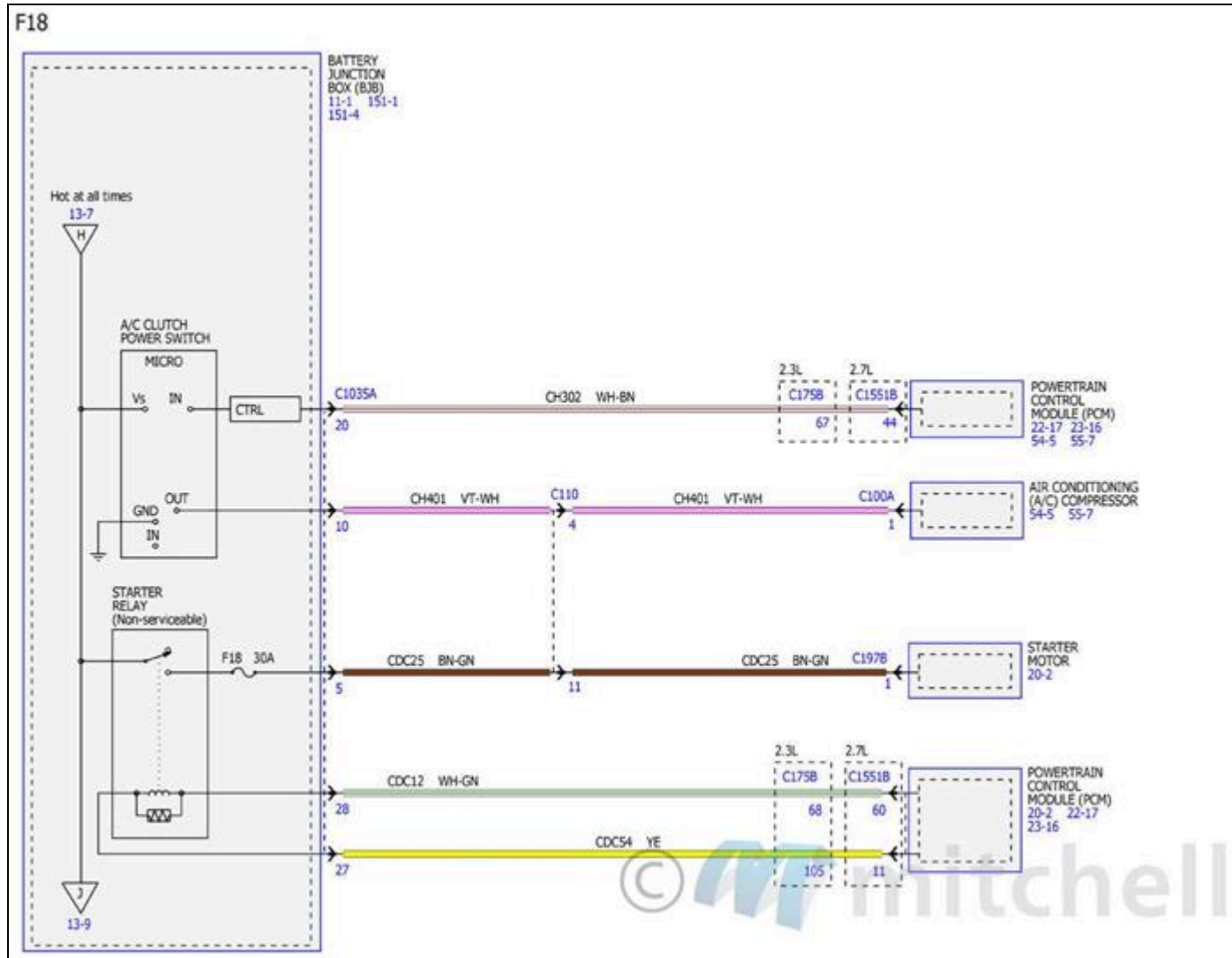

Fig. 138: Power Distribution/BCM Wiring Diagrams (9 Of 34)

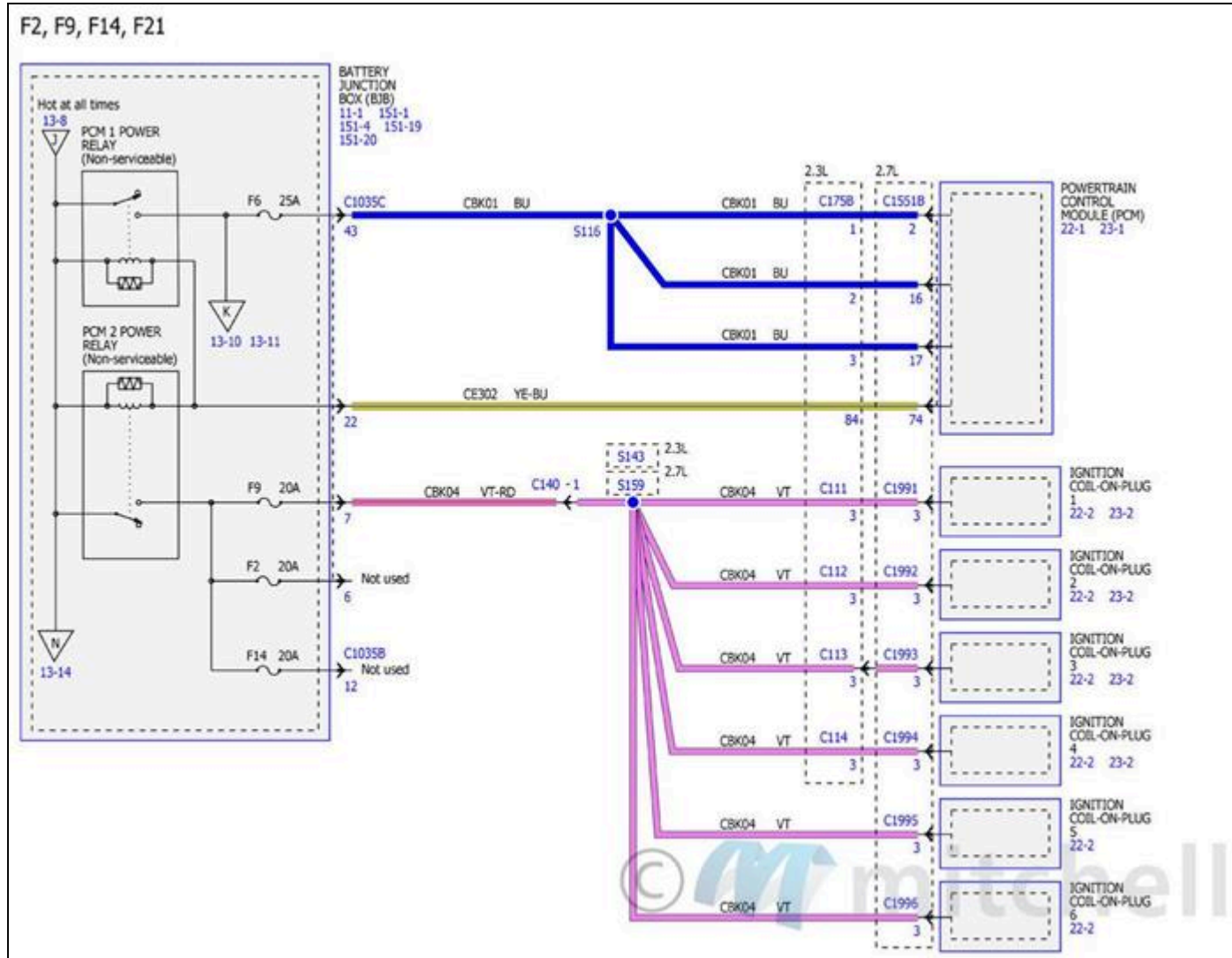

Fig. 139: Power Distribution/BCM Wiring Diagrams (10 Of 34)

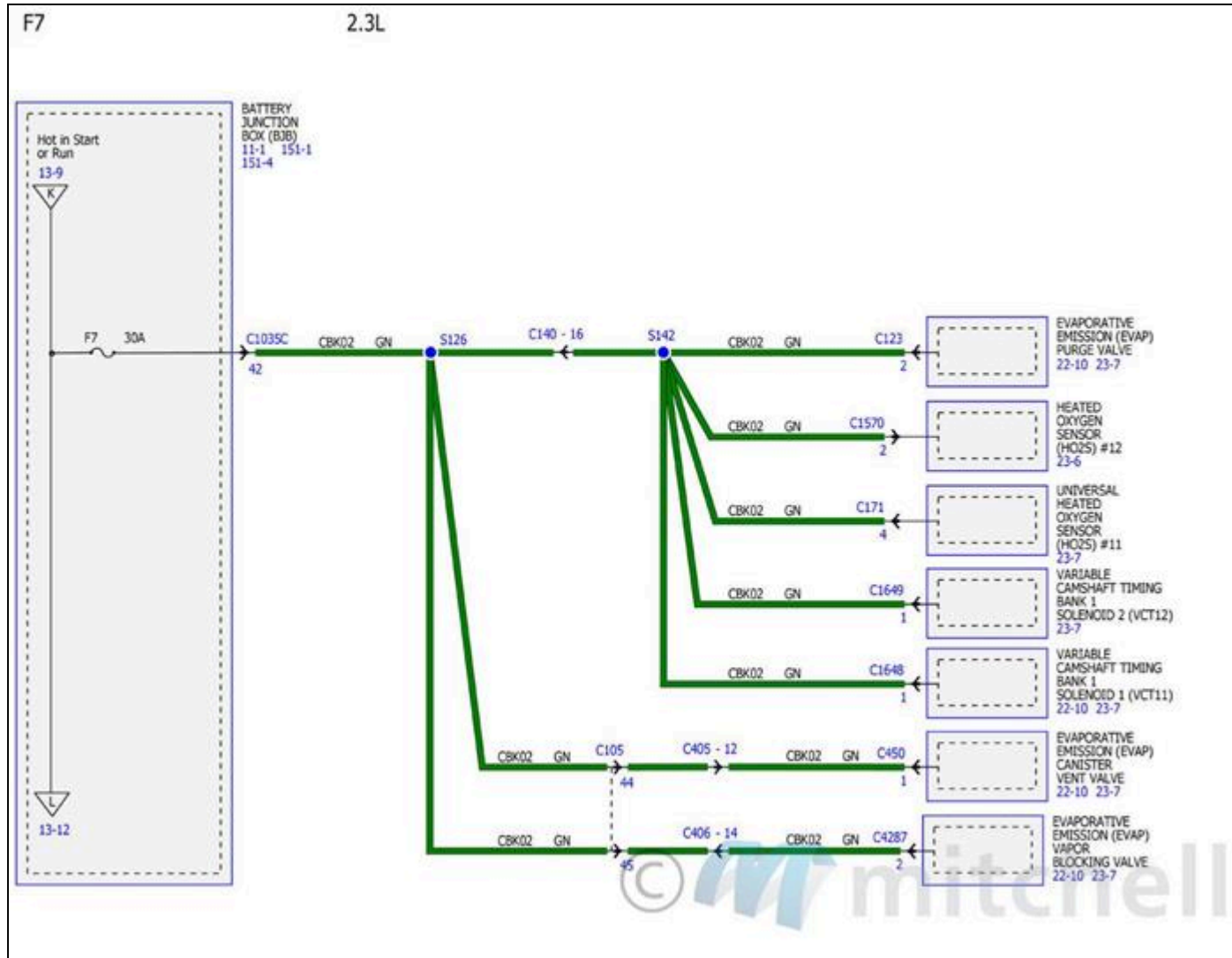

Fig. 140: Power Distribution/BCM Wiring Diagrams (11 Of 34)

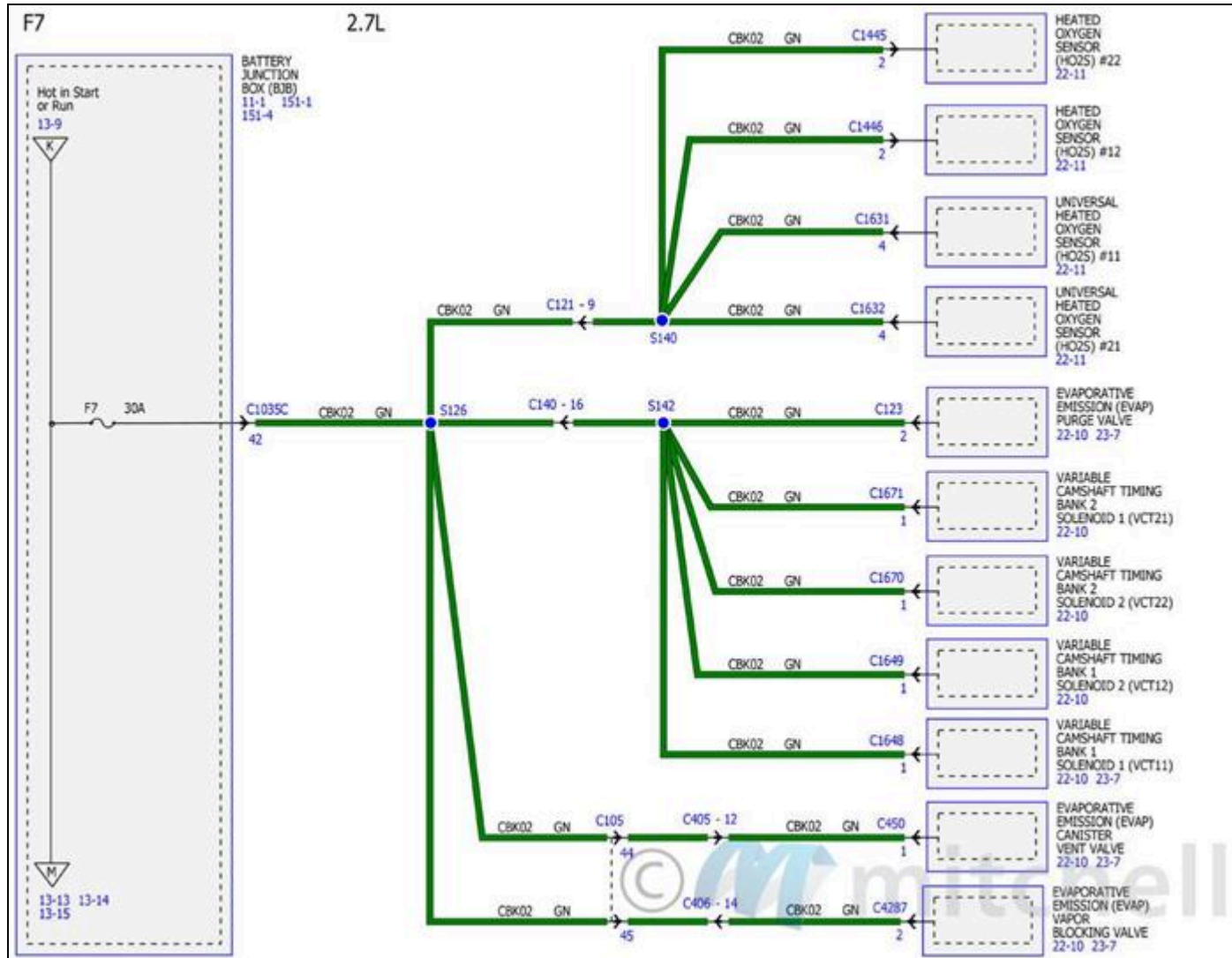

Fig. 141: Power Distribution/BCM Wiring Diagrams (12 Of 34)

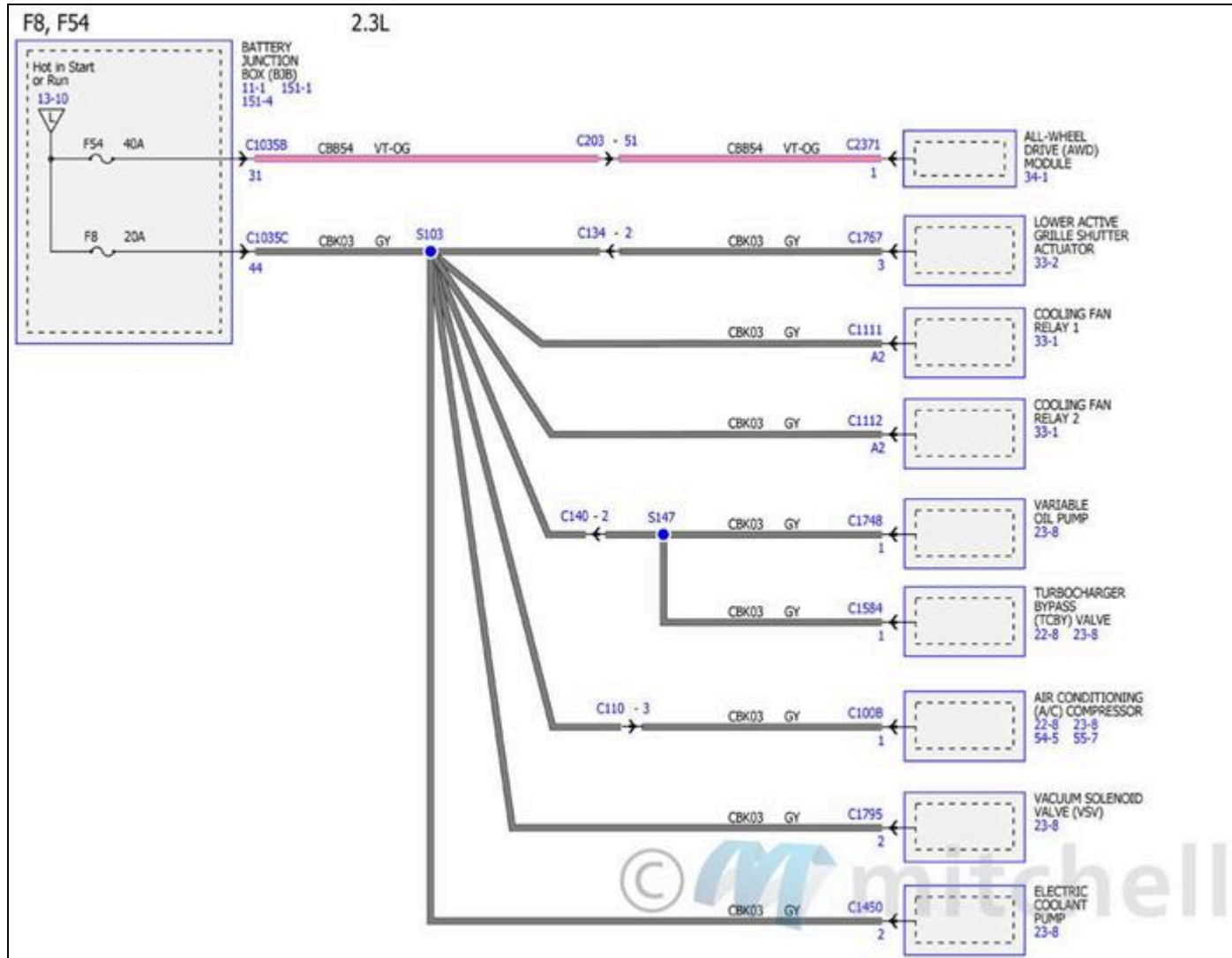

Fig. 142: Power Distribution/BCM Wiring Diagrams (13 Of 34)

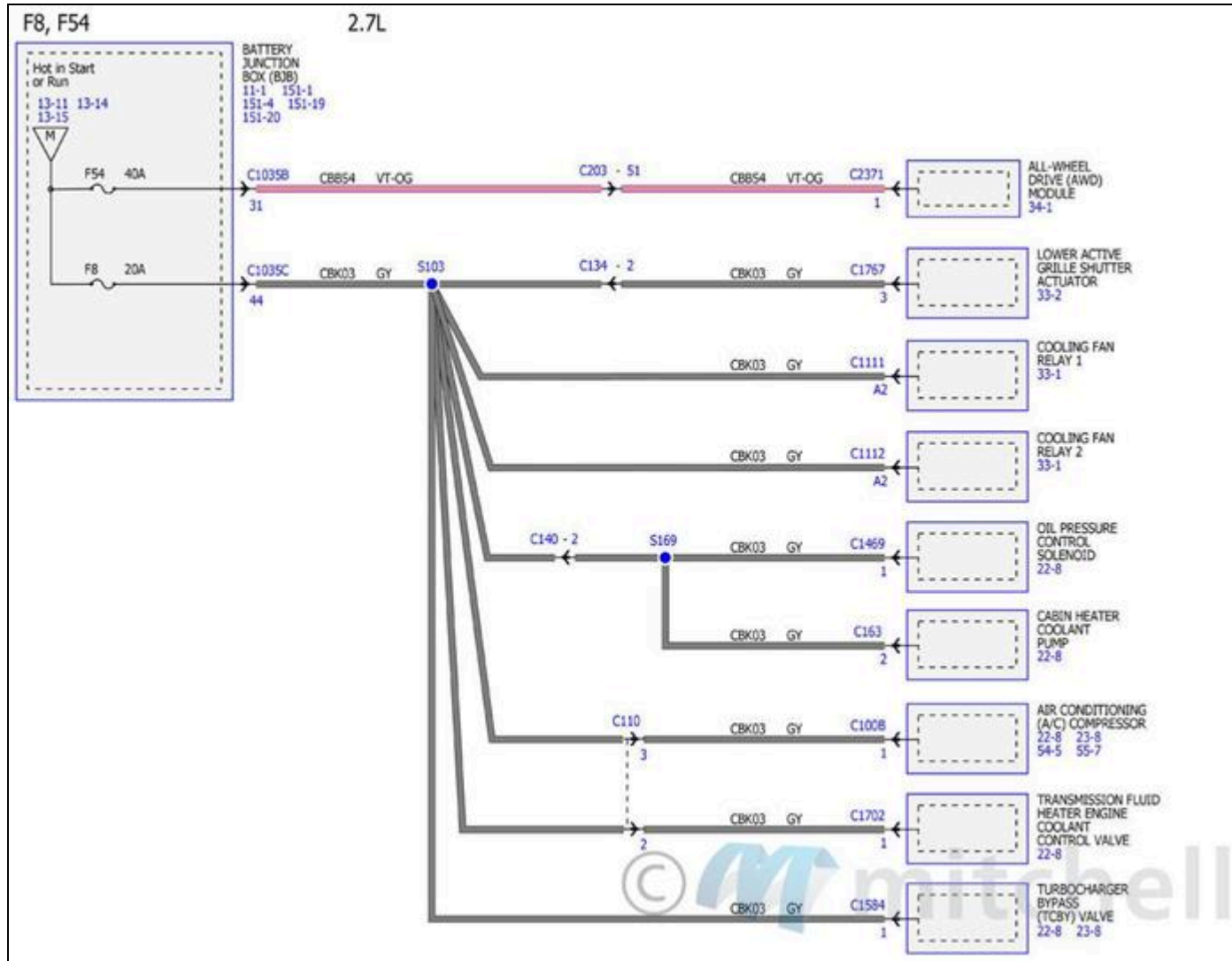

Fig. 143: Power Distribution/BCM Wiring Diagrams (14 Of 34)

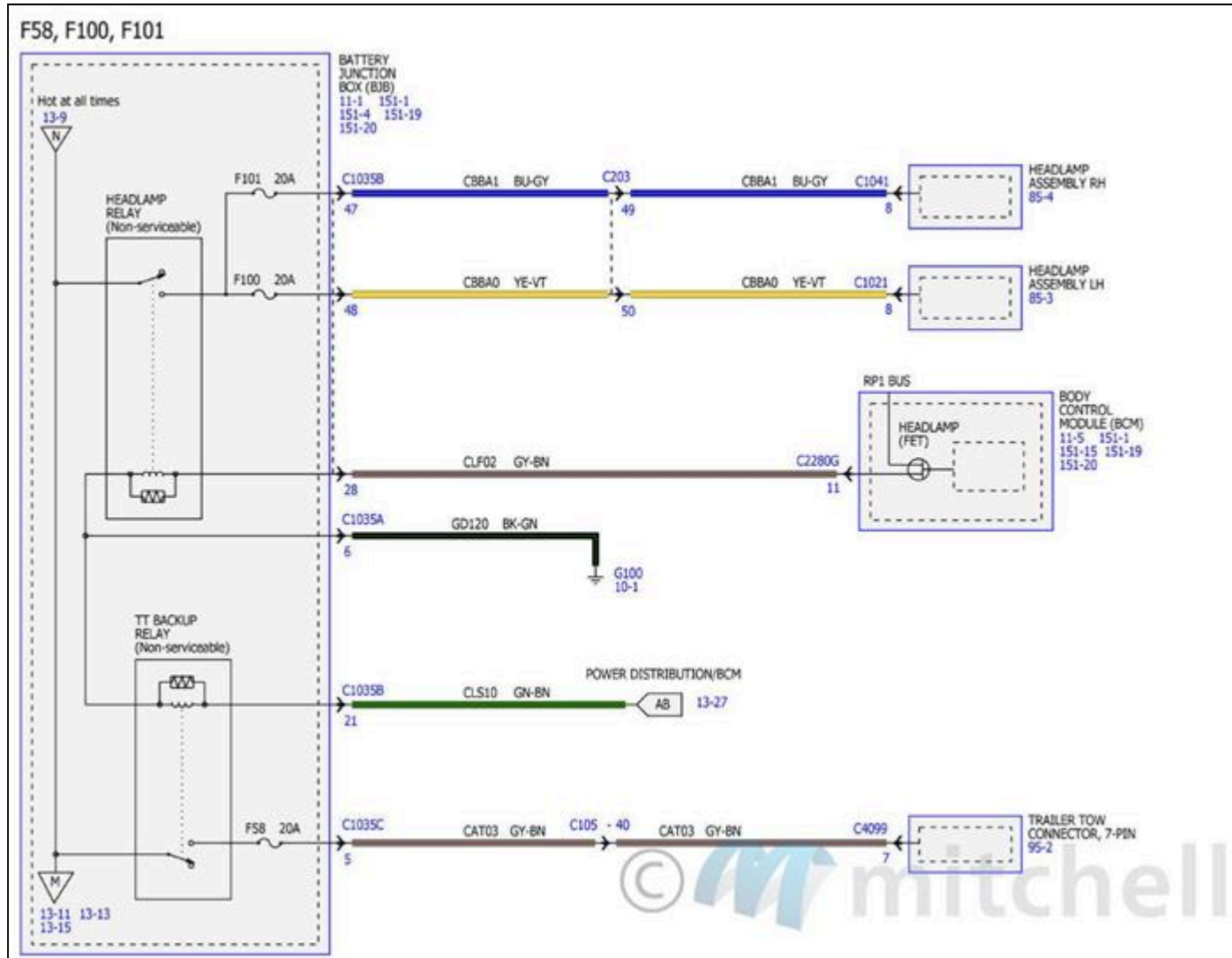

Fig. 145: Power Distribution/BCM Wiring Diagrams (16 Of 34)

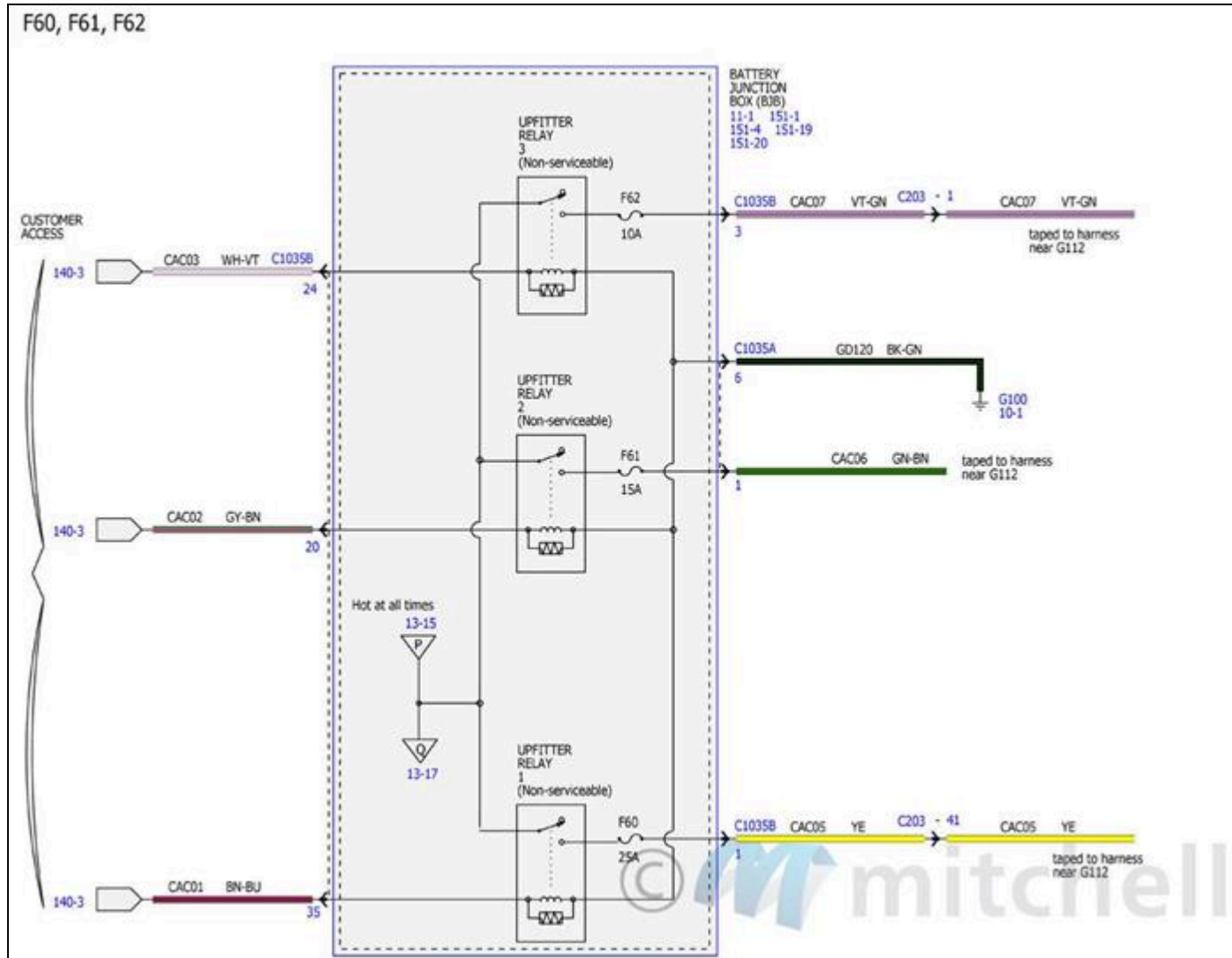

Fig. 146: Power Distribution/BCM Wiring Diagrams (17 Of 34)

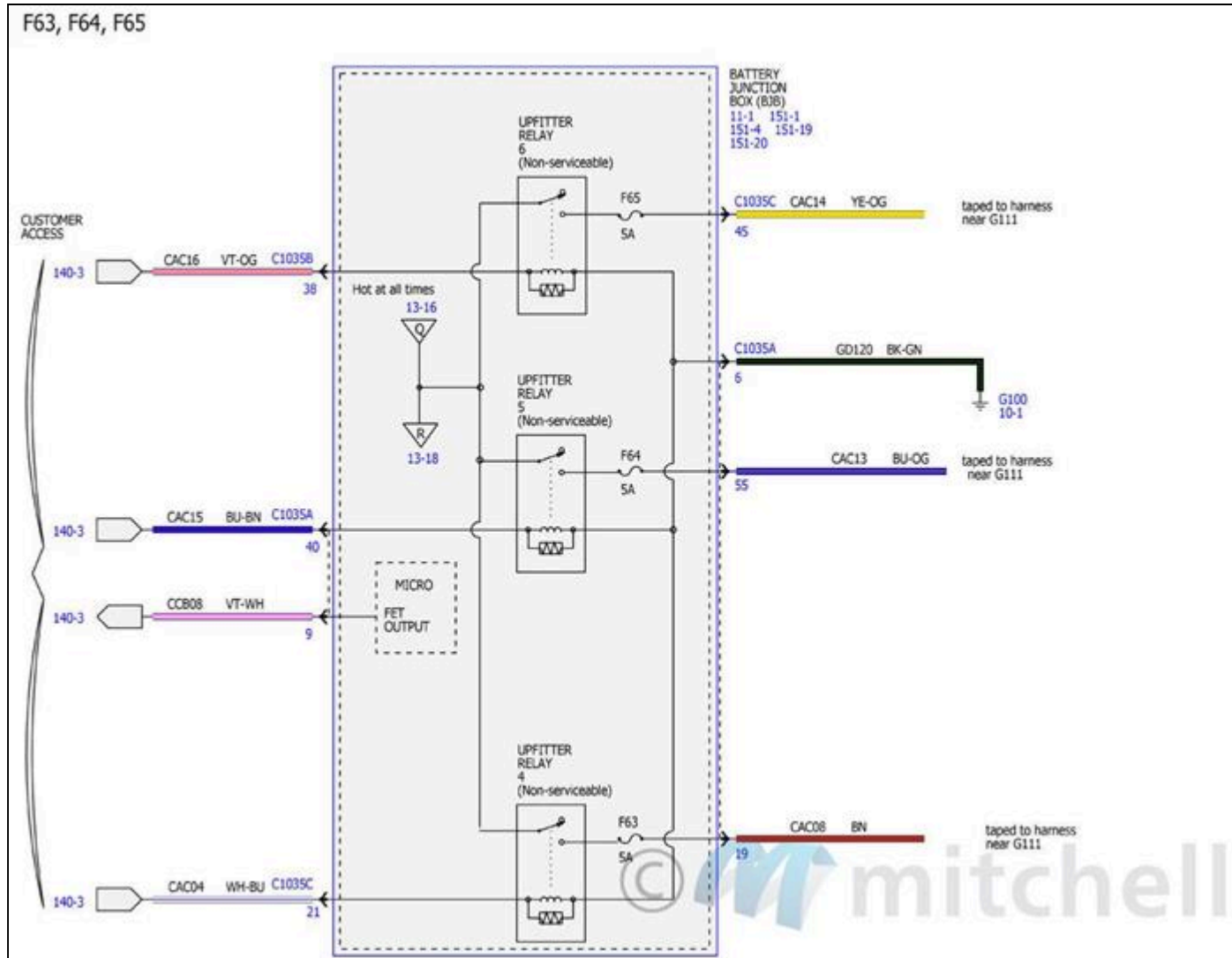

Fig. 147: Power Distribution/BCM Wiring Diagrams (18 Of 34)

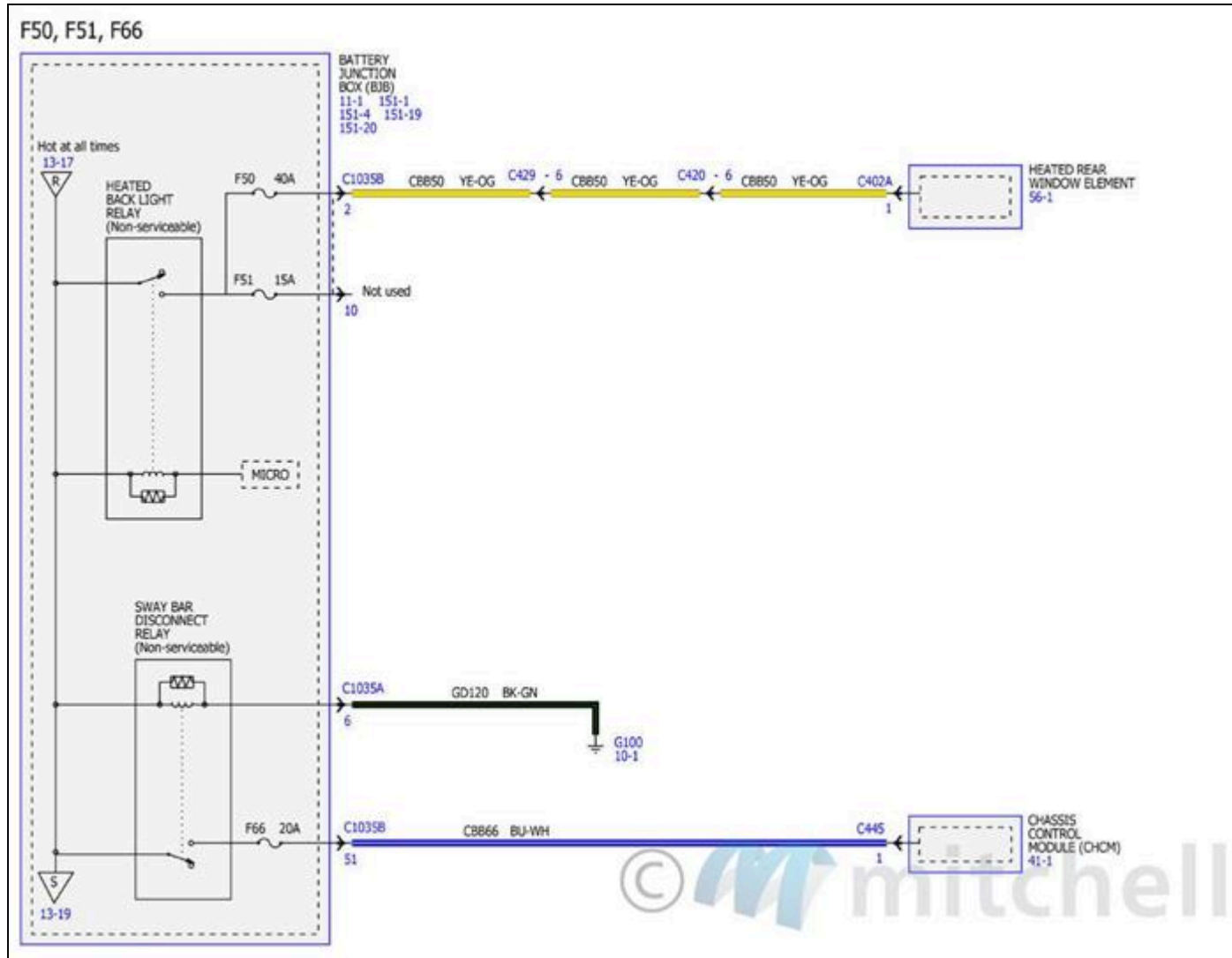

Fig. 148: Power Distribution/BCM Wiring Diagrams (19 Of 34)

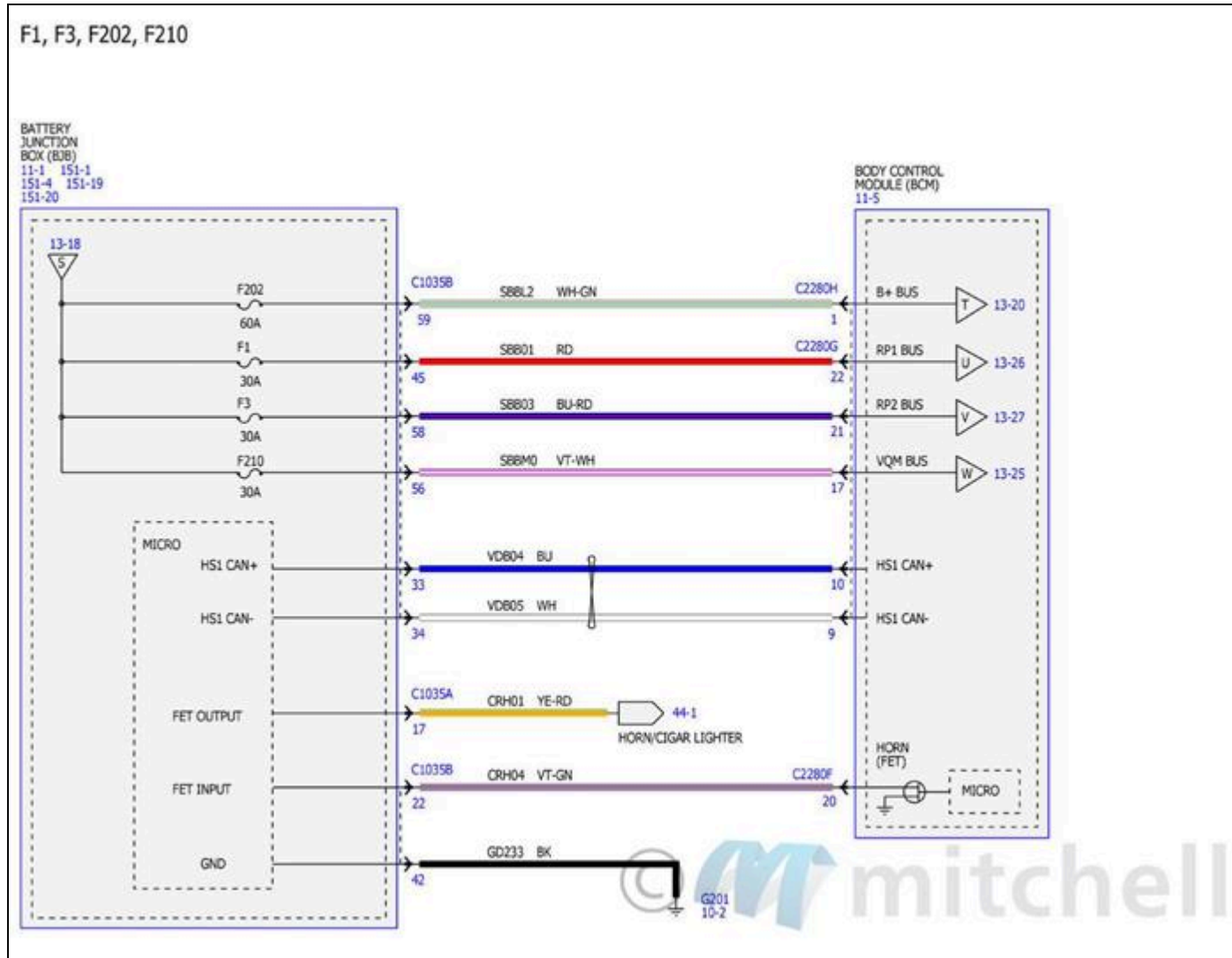

Fig. 149: Power Distribution/BCM Wiring Diagrams (20 Of 34)

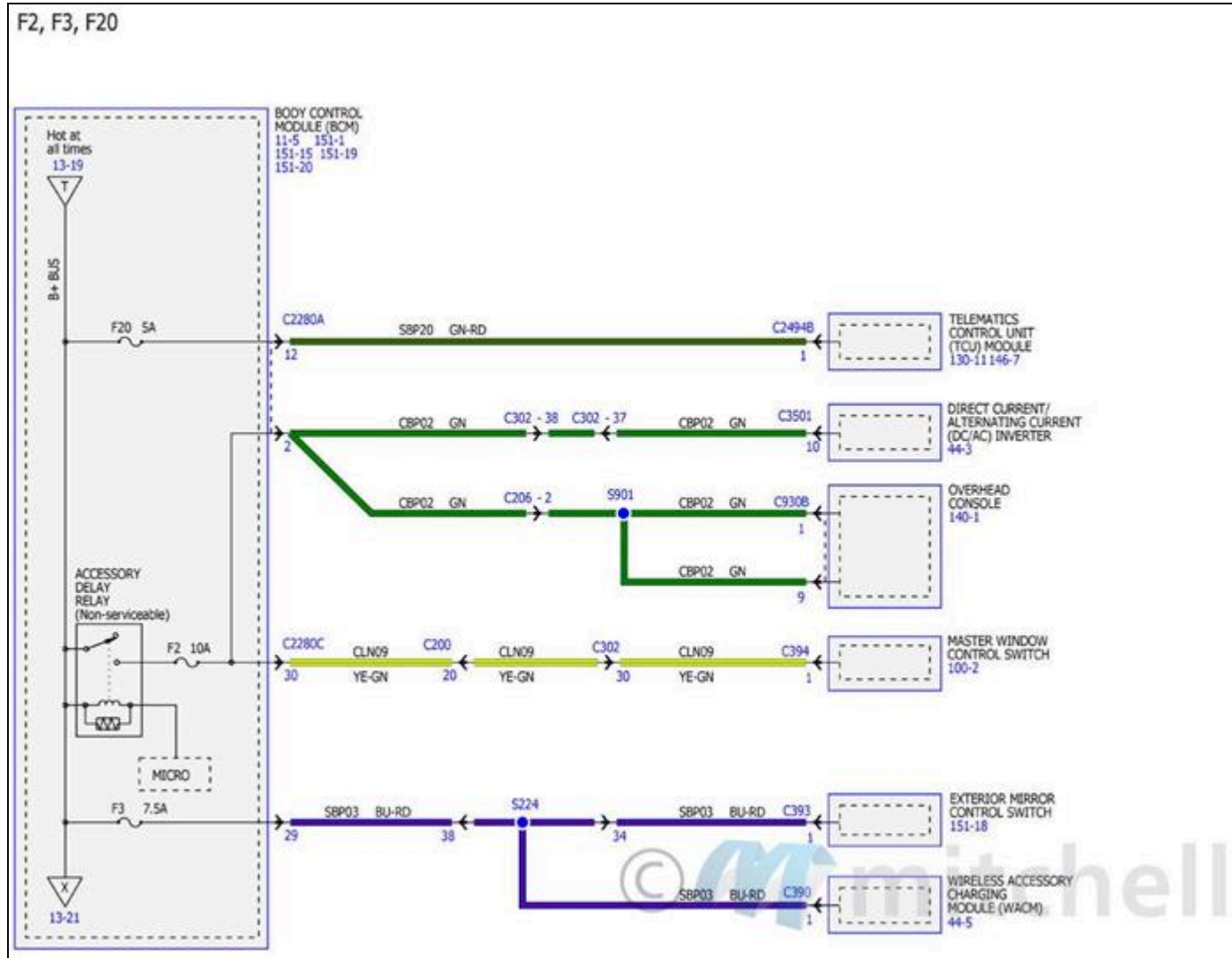

Fig. 150: Power Distribution/BCM Wiring Diagrams (21 Of 34)

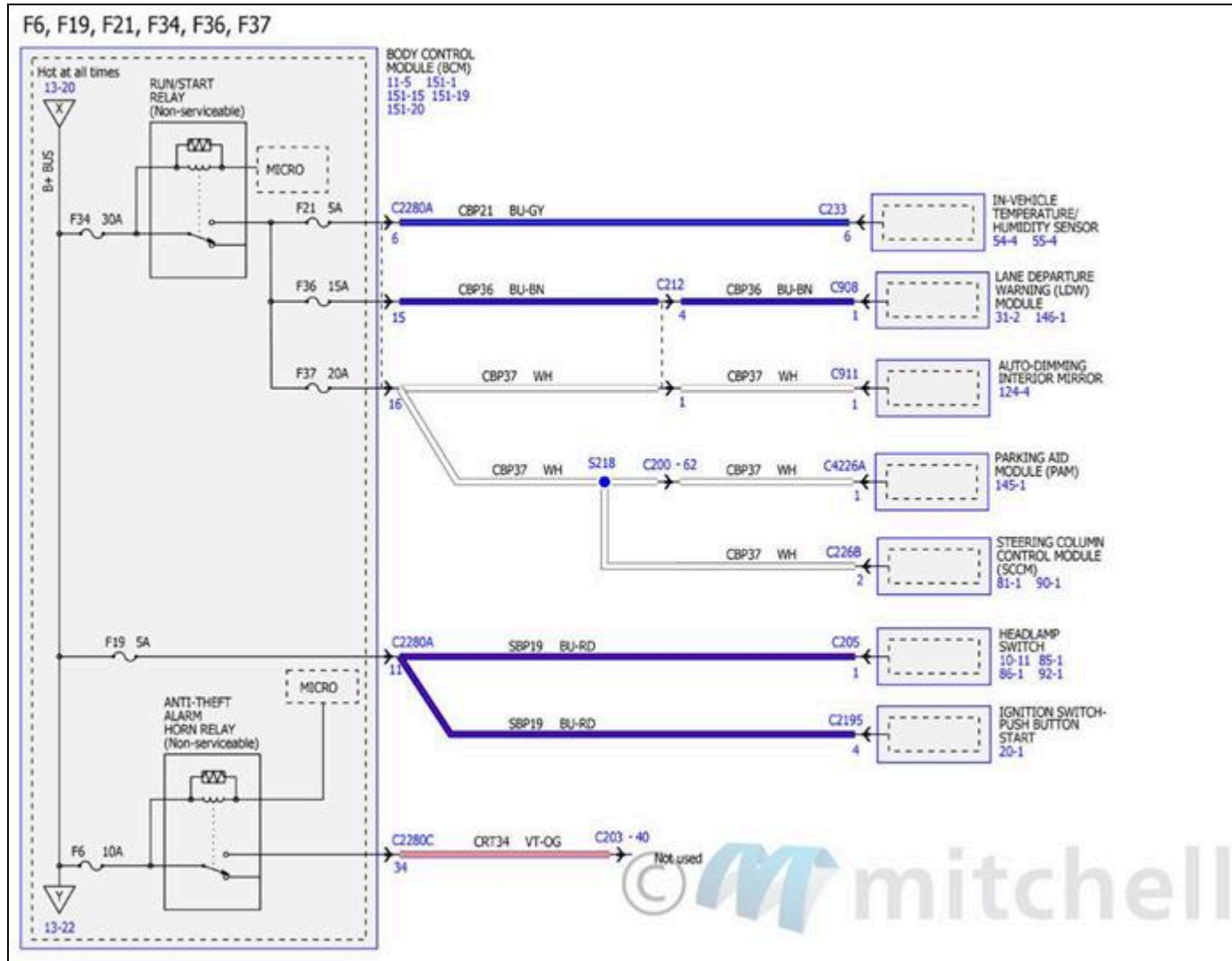

Fig. 151: Power Distribution/BCM Wiring Diagrams (22 Of 34)

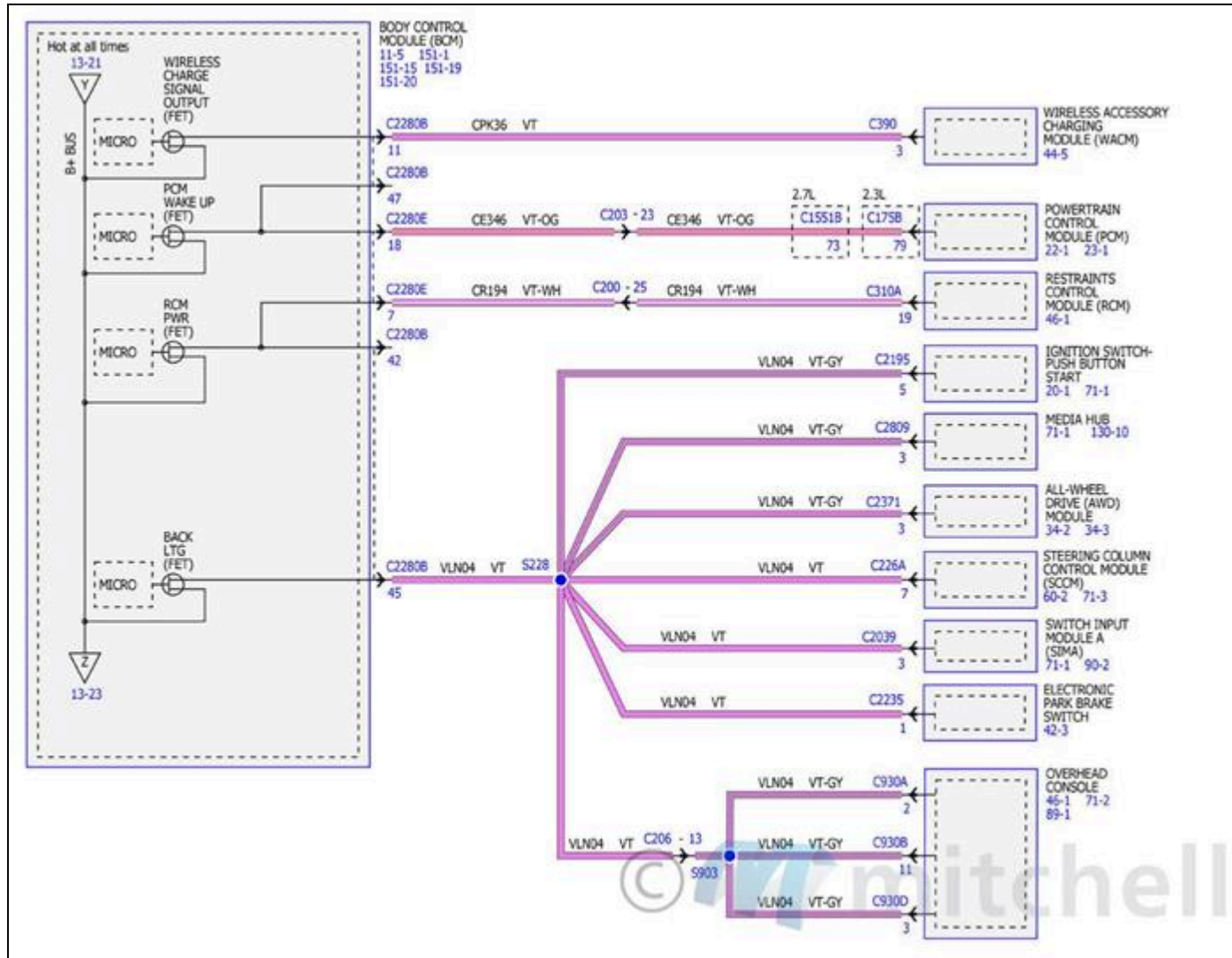

Fig. 152: Power Distribution/BCM Wiring Diagrams (23 Of 34)

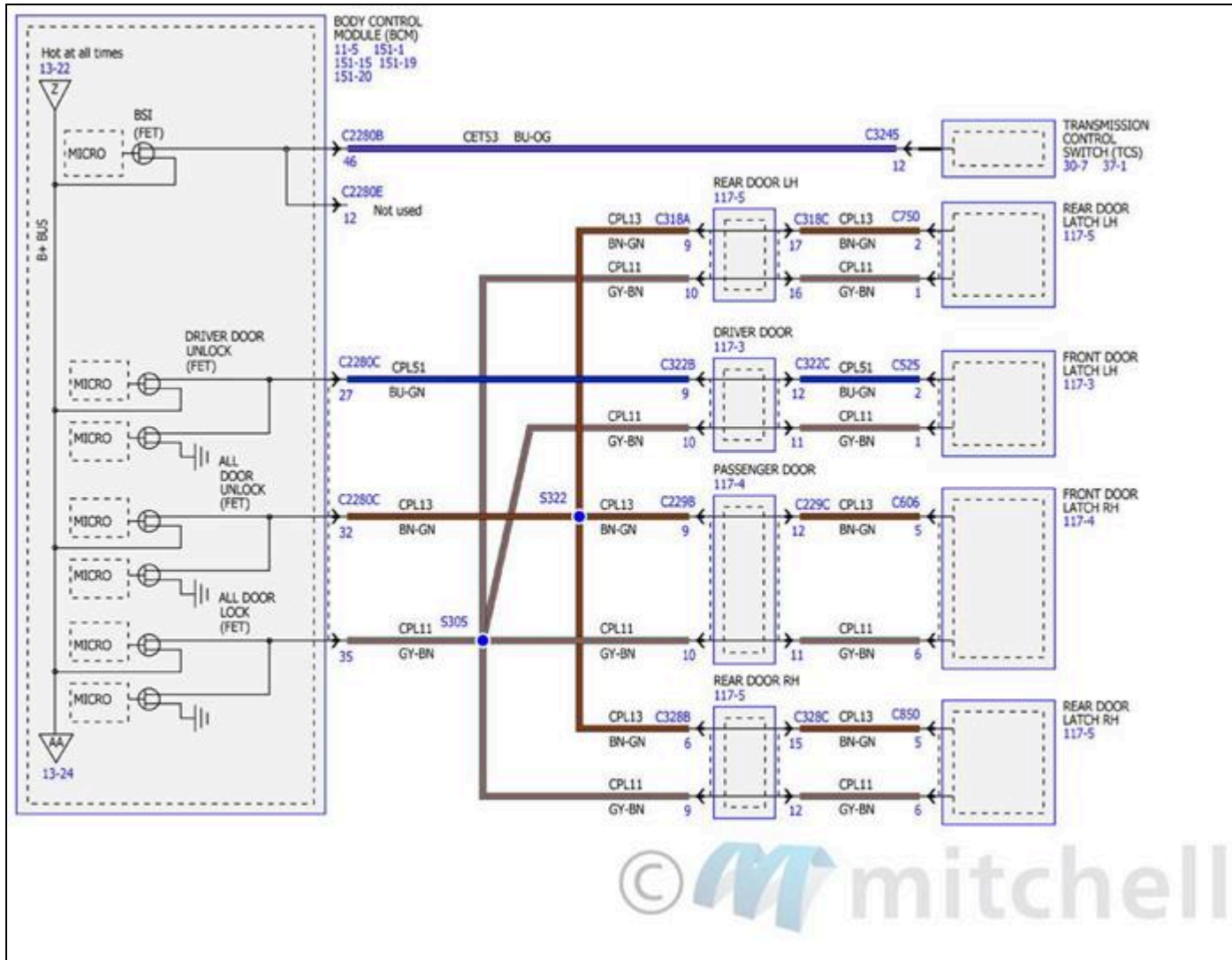

Fig. 153: Power Distribution/BCM Wiring Diagrams (24 Of 34)

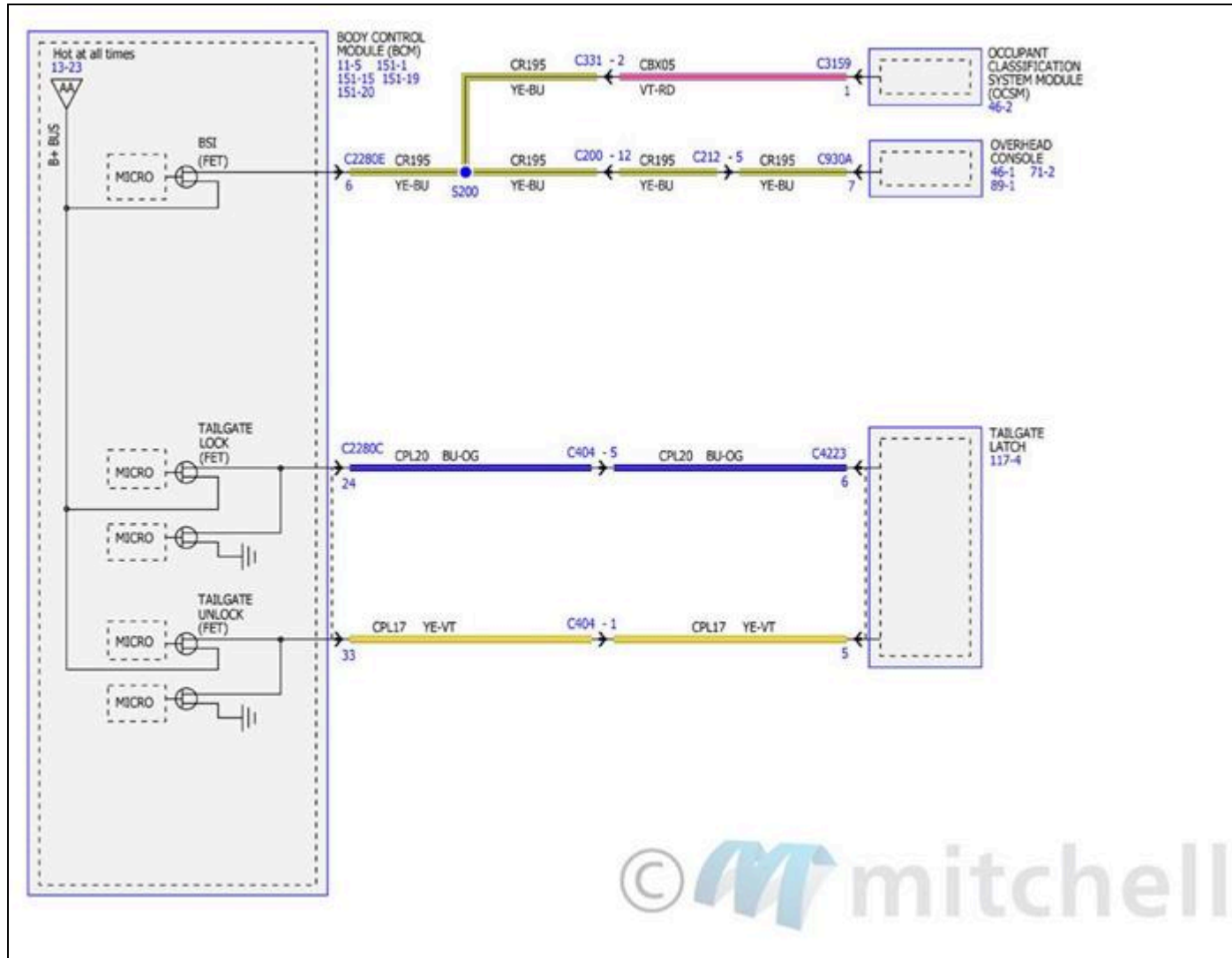

Fig. 154: Power Distribution/BCM Wiring Diagrams (25 Of 34)

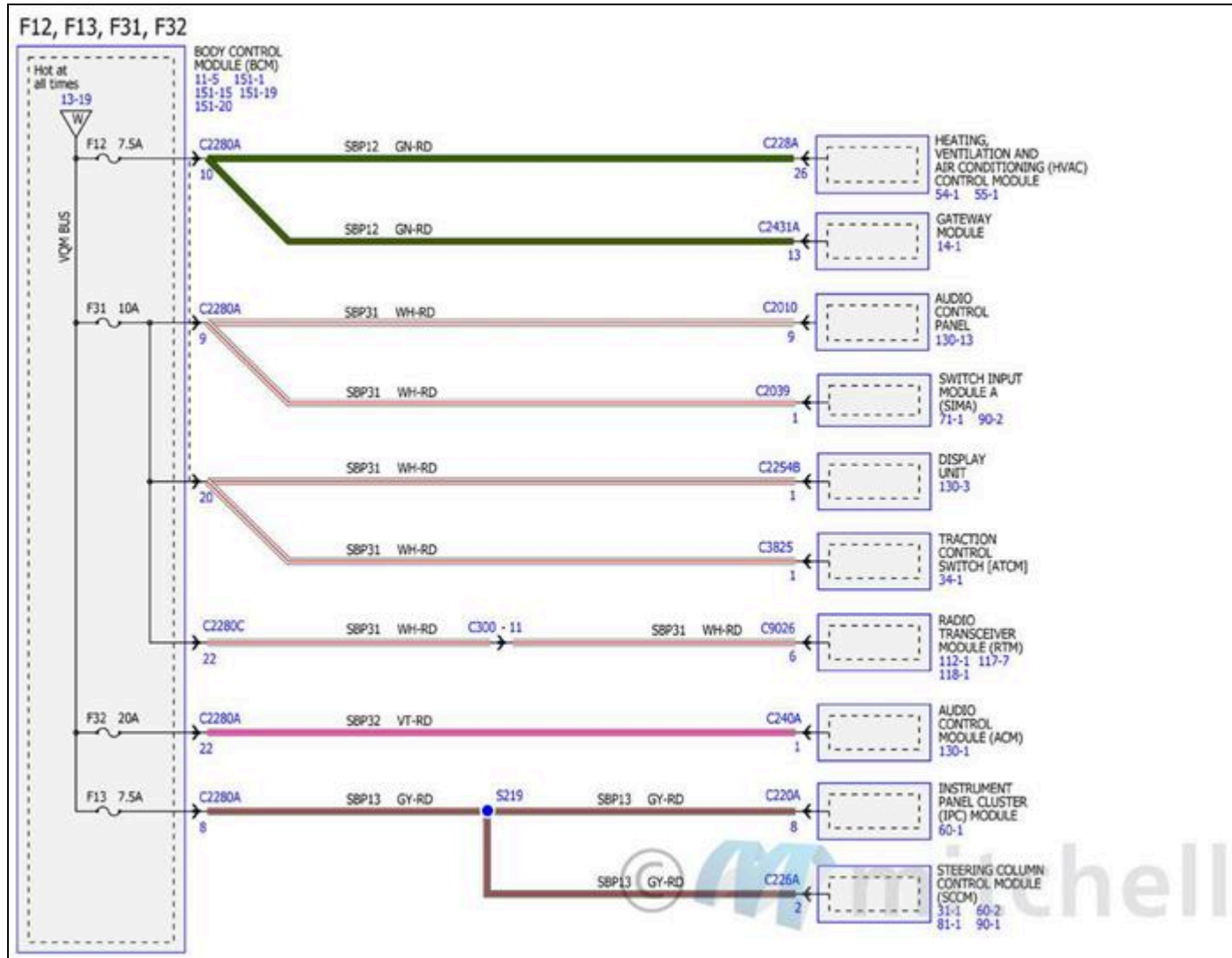

Fig. 155: Power Distribution/BCM Wiring Diagrams (26 Of 34)

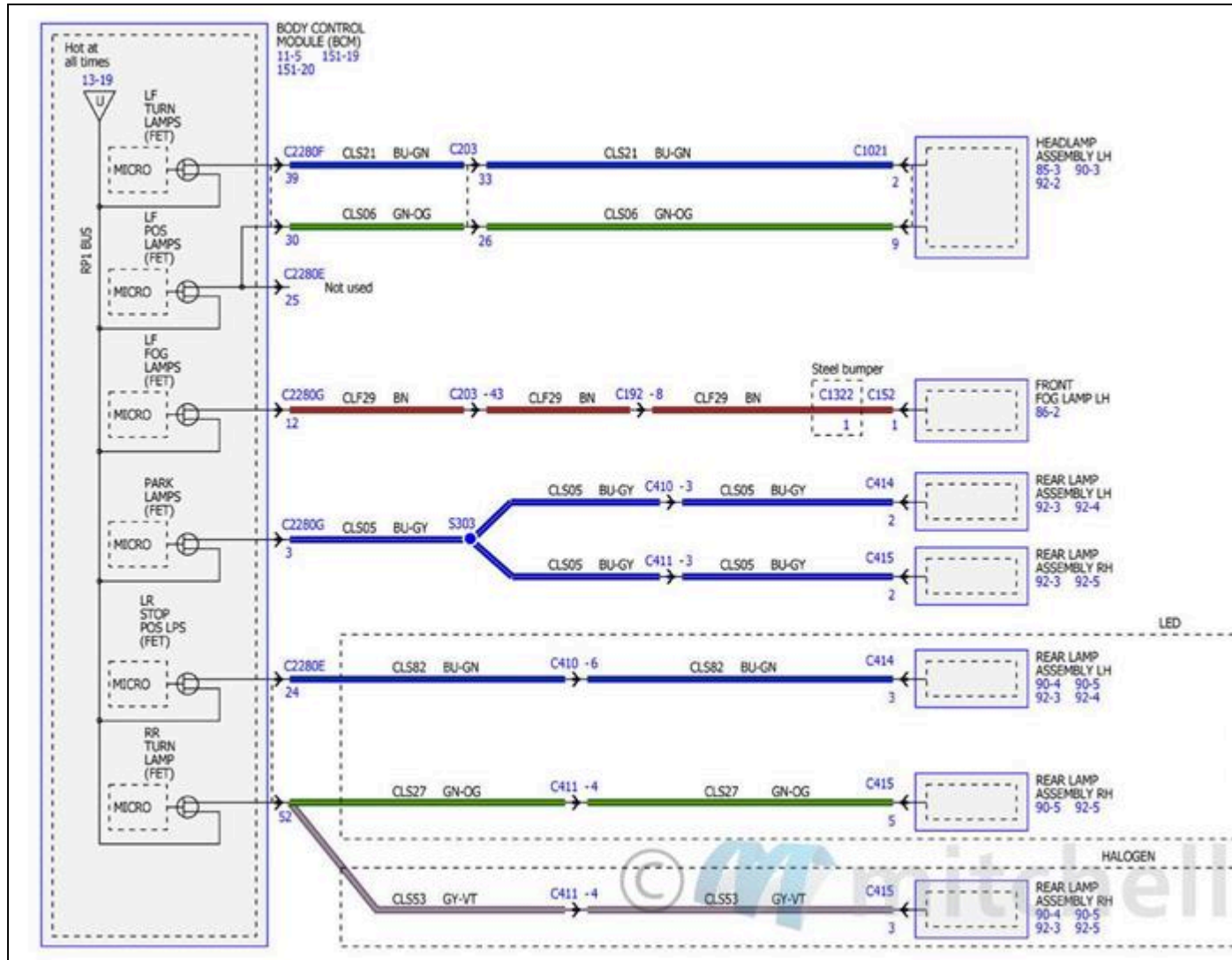

Fig. 156: Power Distribution/BCM Wiring Diagrams (27 Of 34)

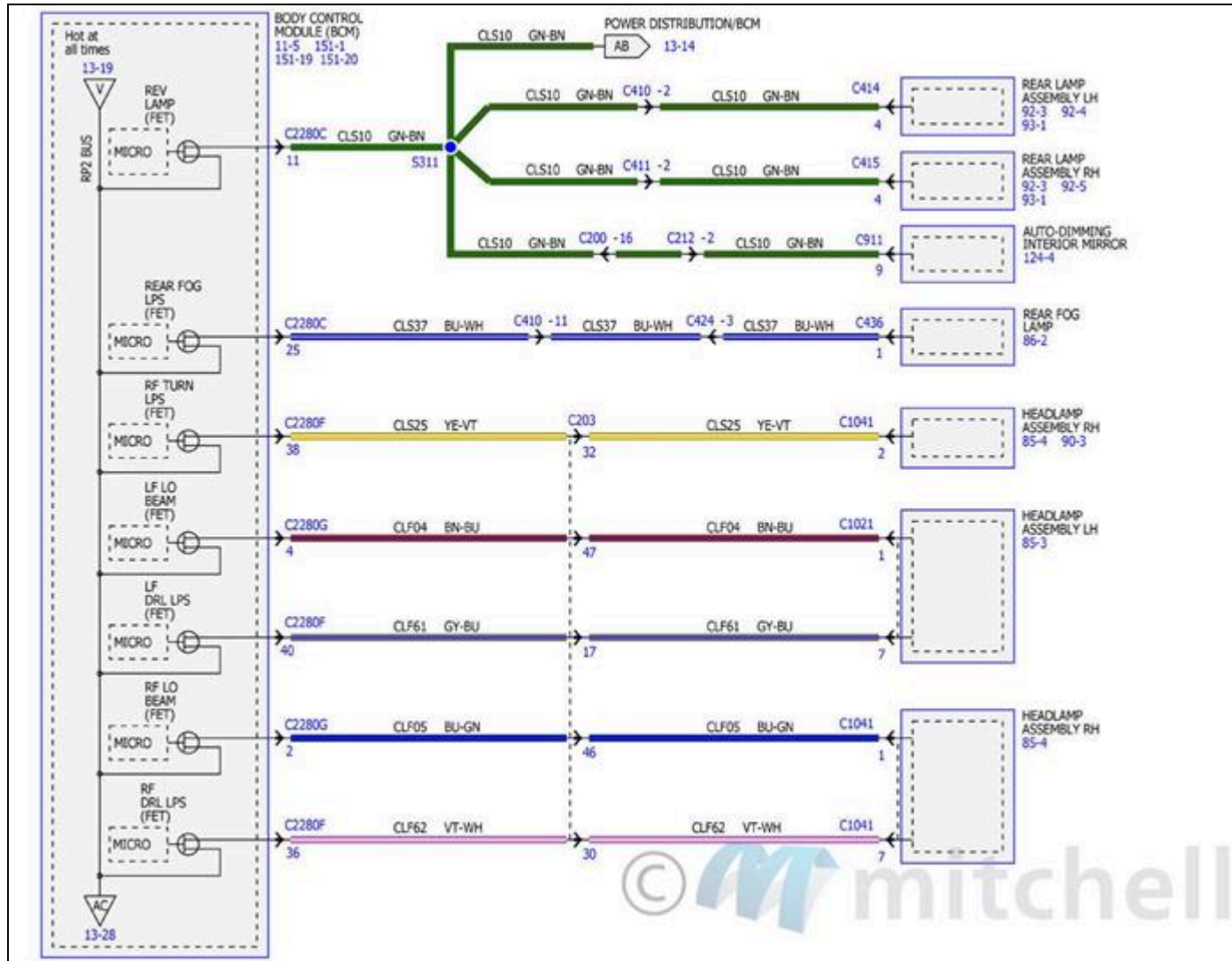

Fig. 157: Power Distribution/BCM Wiring Diagrams (28 Of 34)

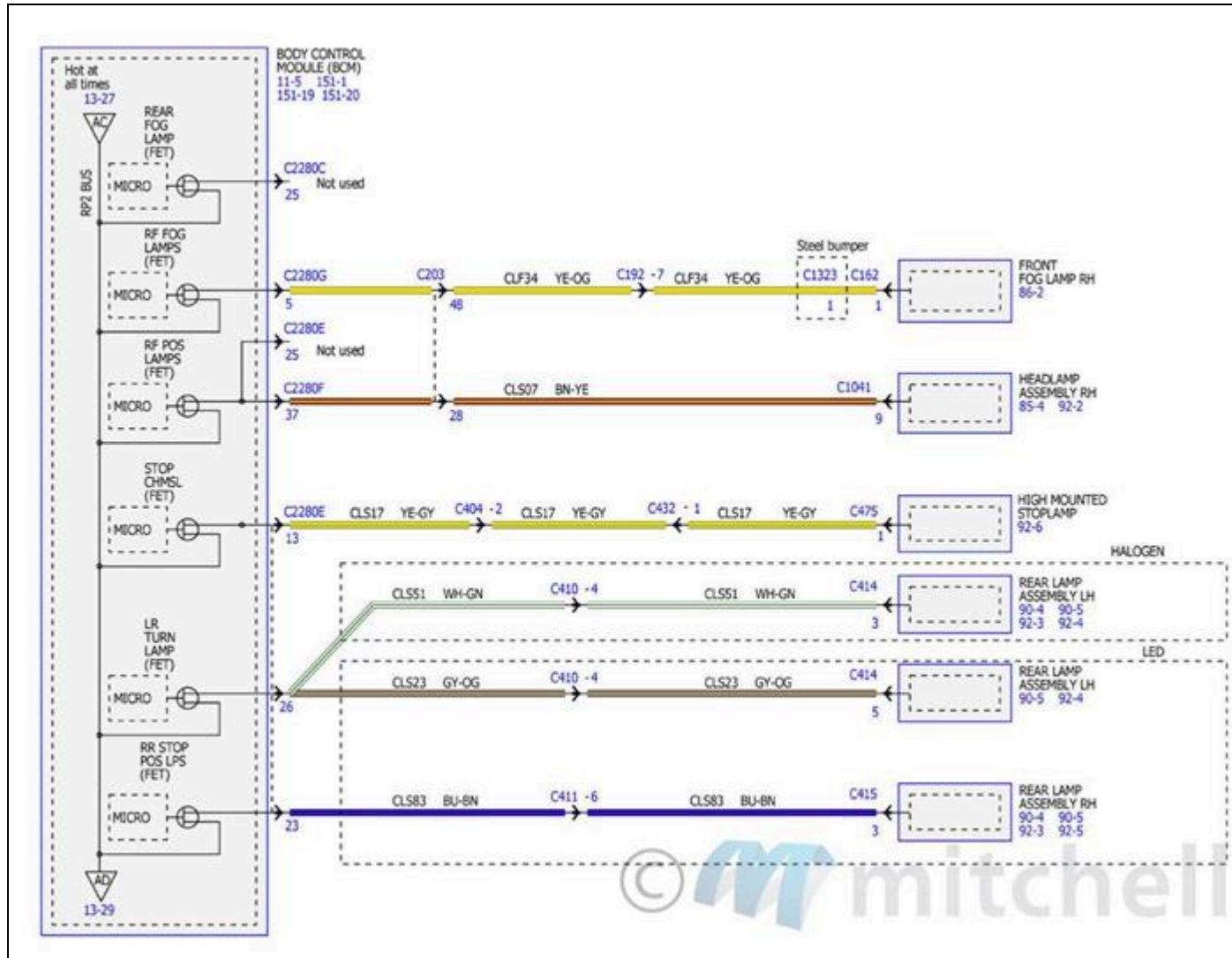

Fig. 158: Power Distribution/BCM Wiring Diagrams (29 Of 34)

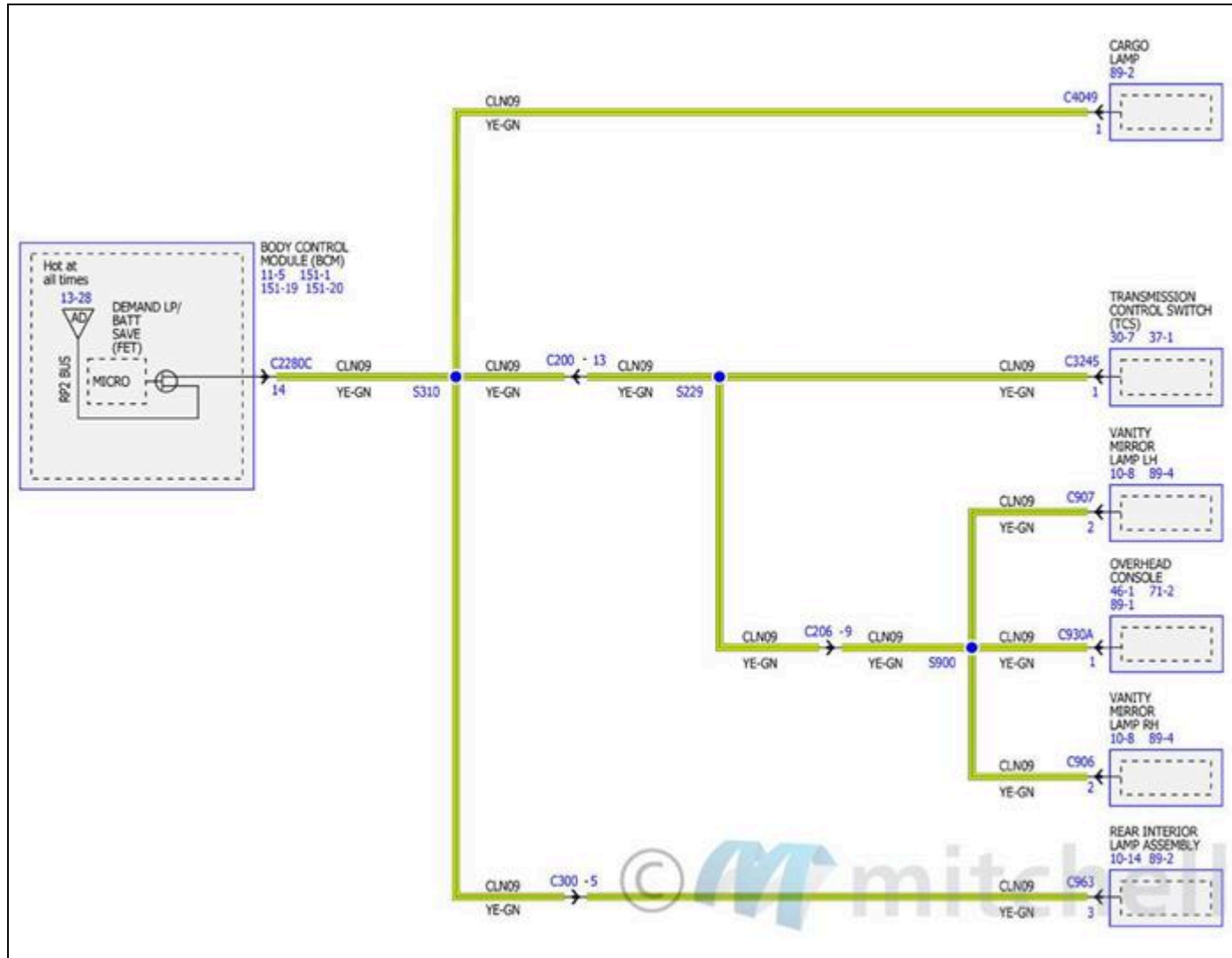

Fig. 159: Power Distribution/BCM Wiring Diagrams (30 Of 34)

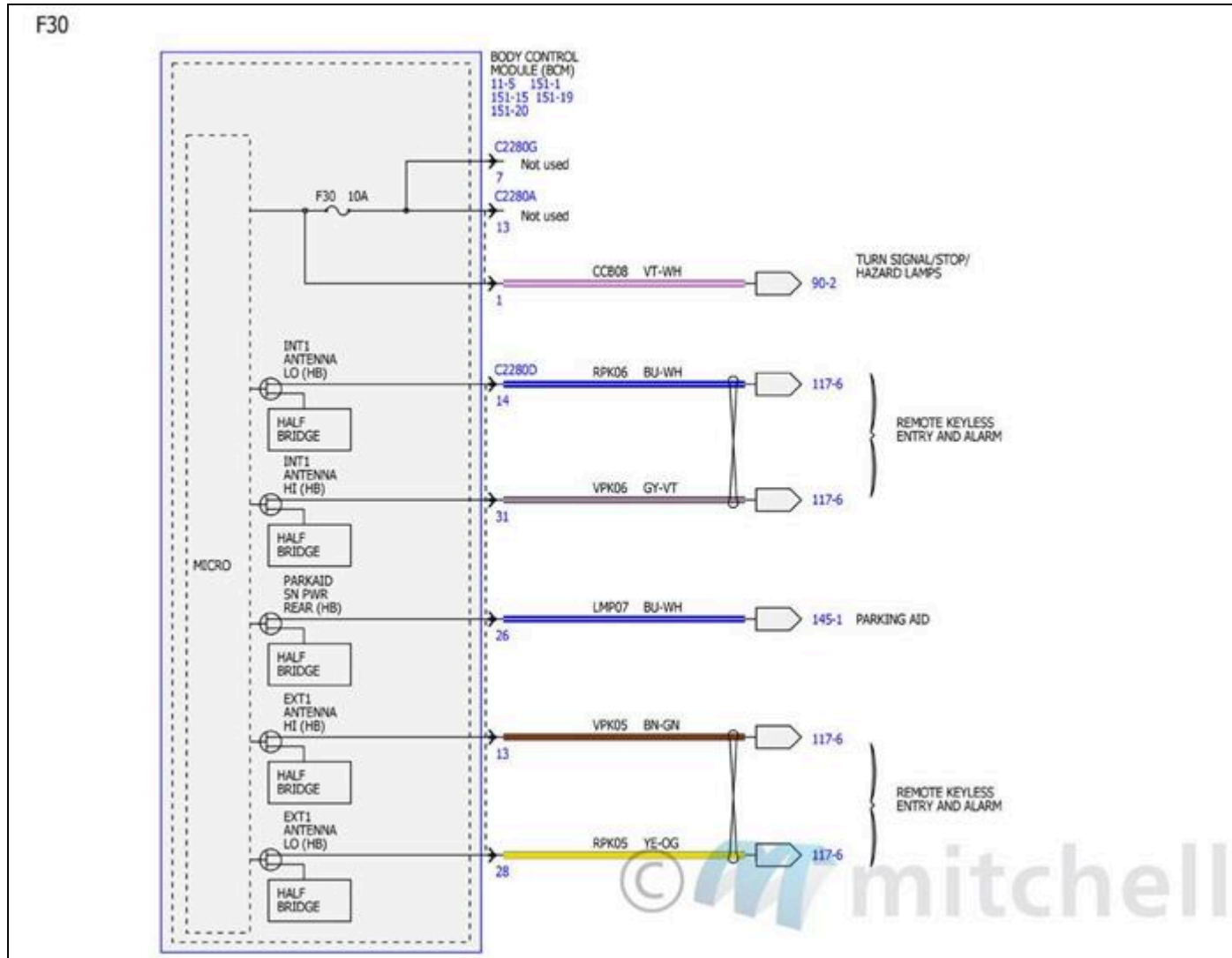

Fig. 160: Power Distribution/BCM Wiring Diagrams (31 Of 34)

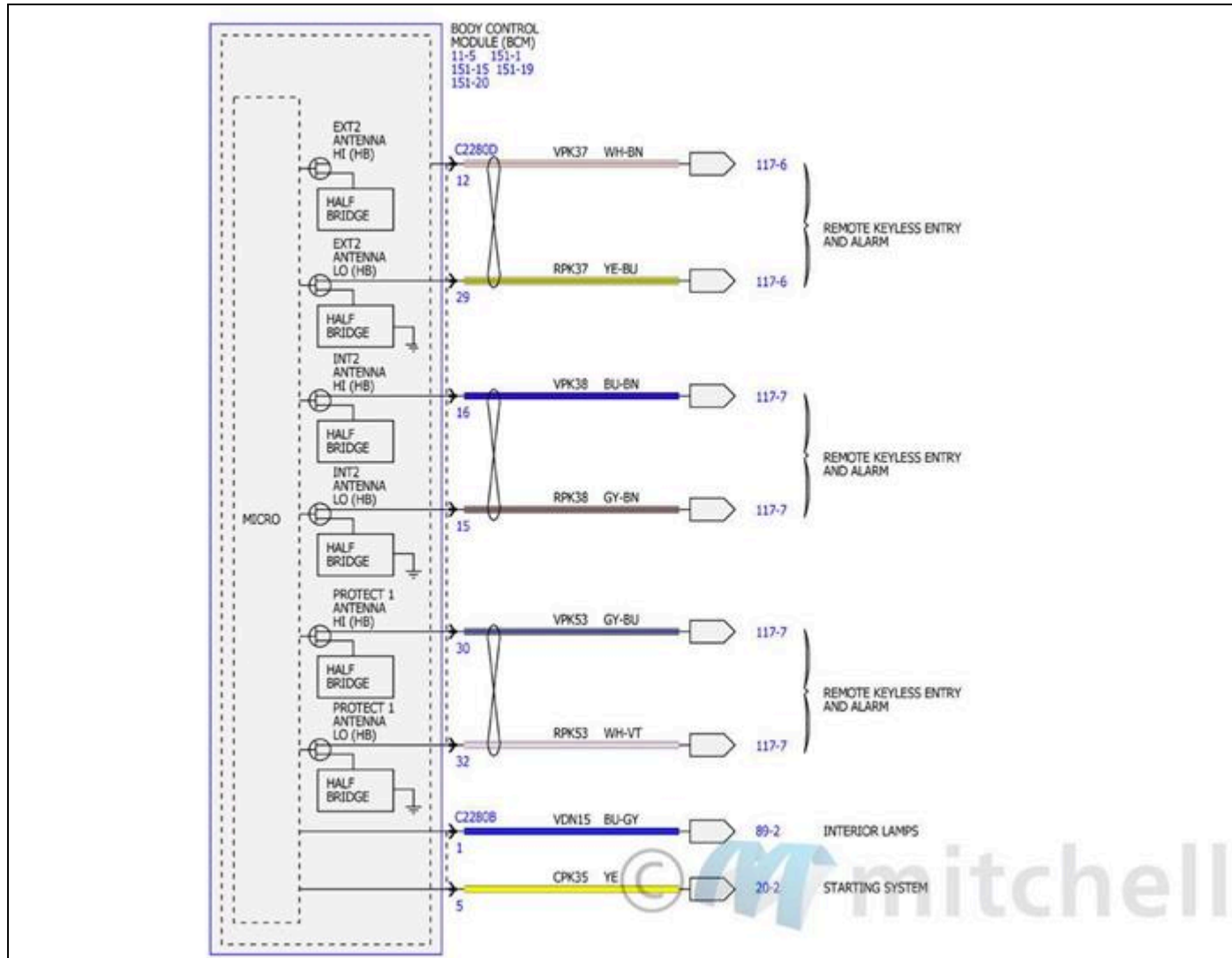

Fig. 161: Power Distribution/BCM Wiring Diagrams (32 Of 34)

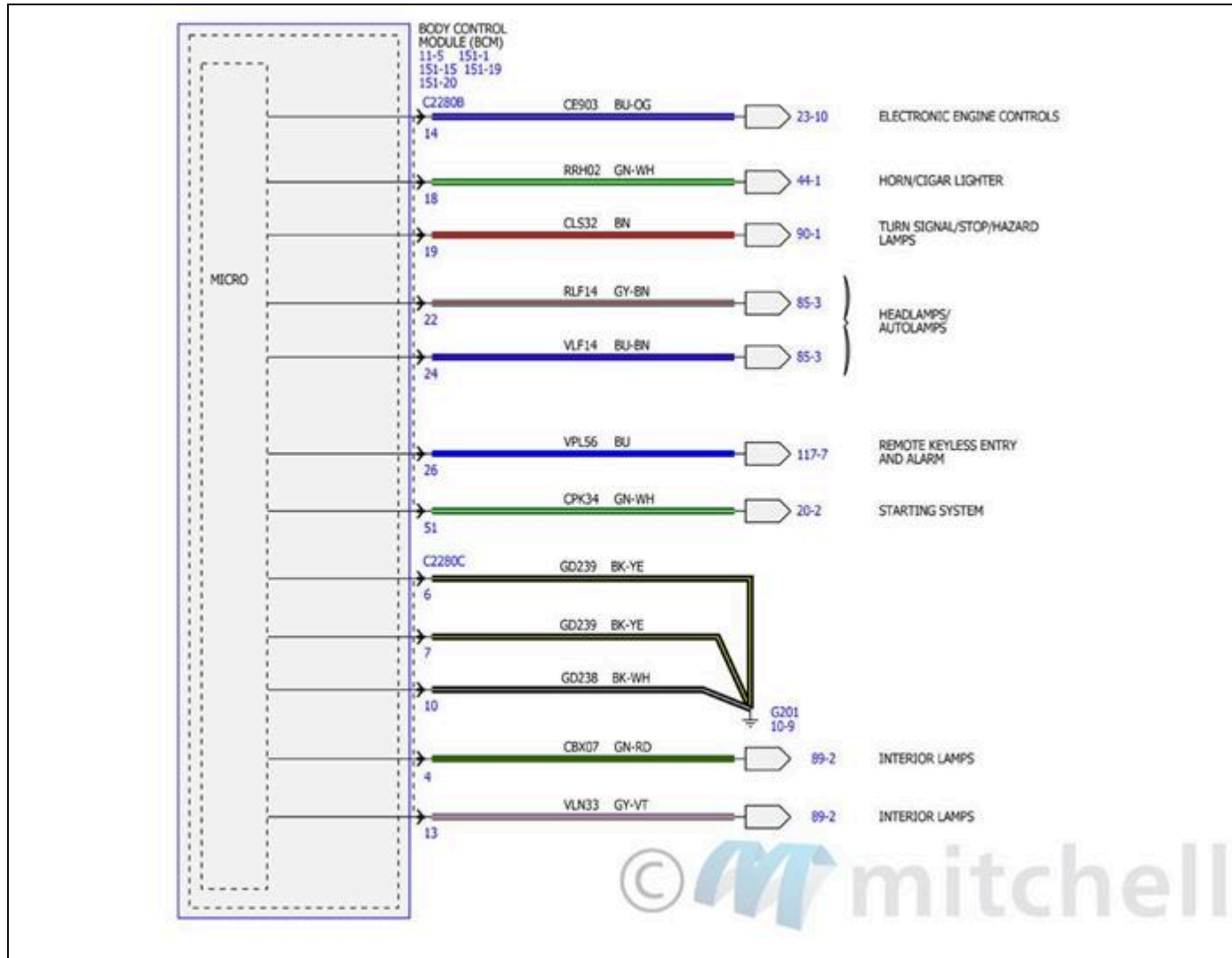

Fig. 162: Power Distribution/BCM Wiring Diagrams (33 Of 34)

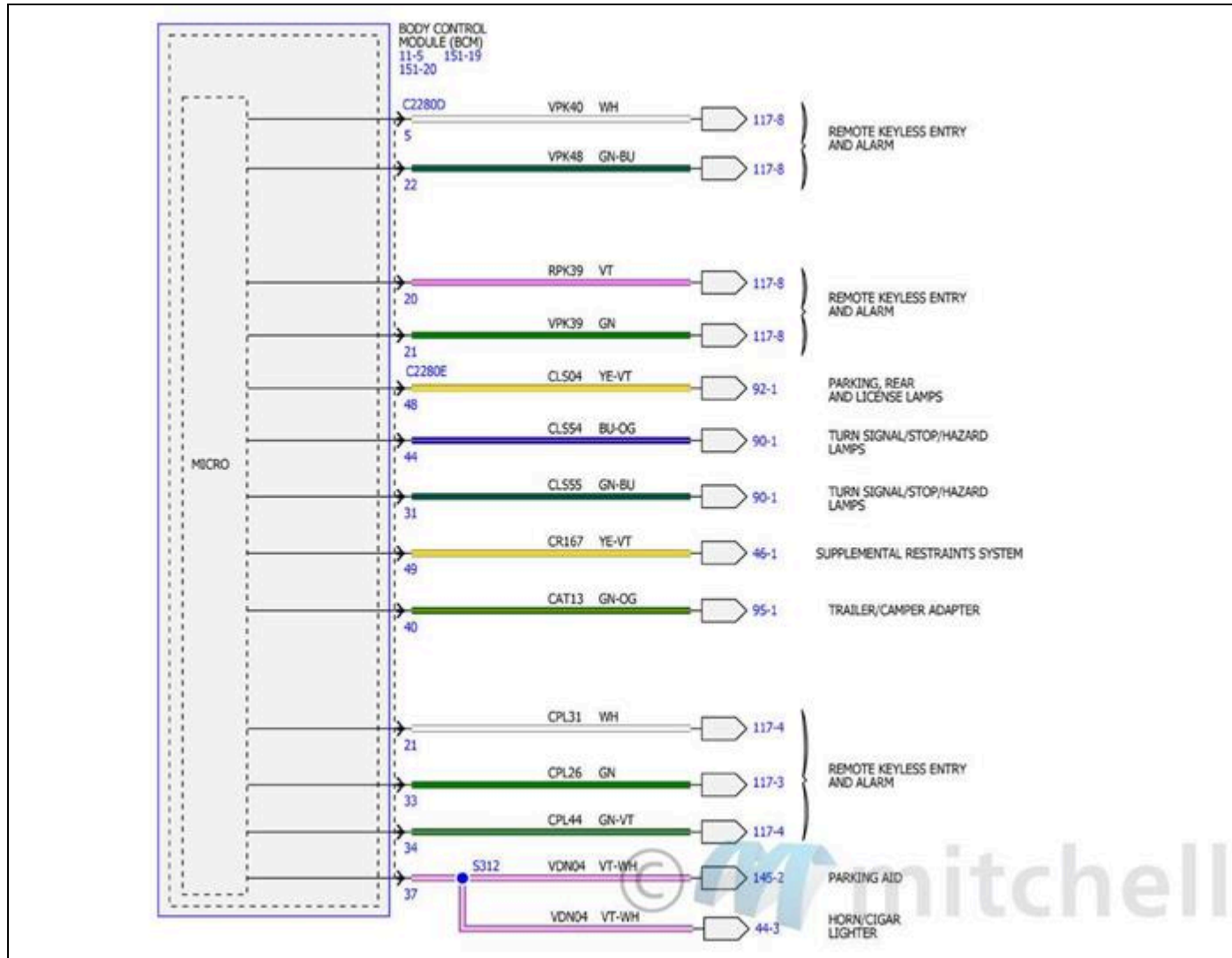
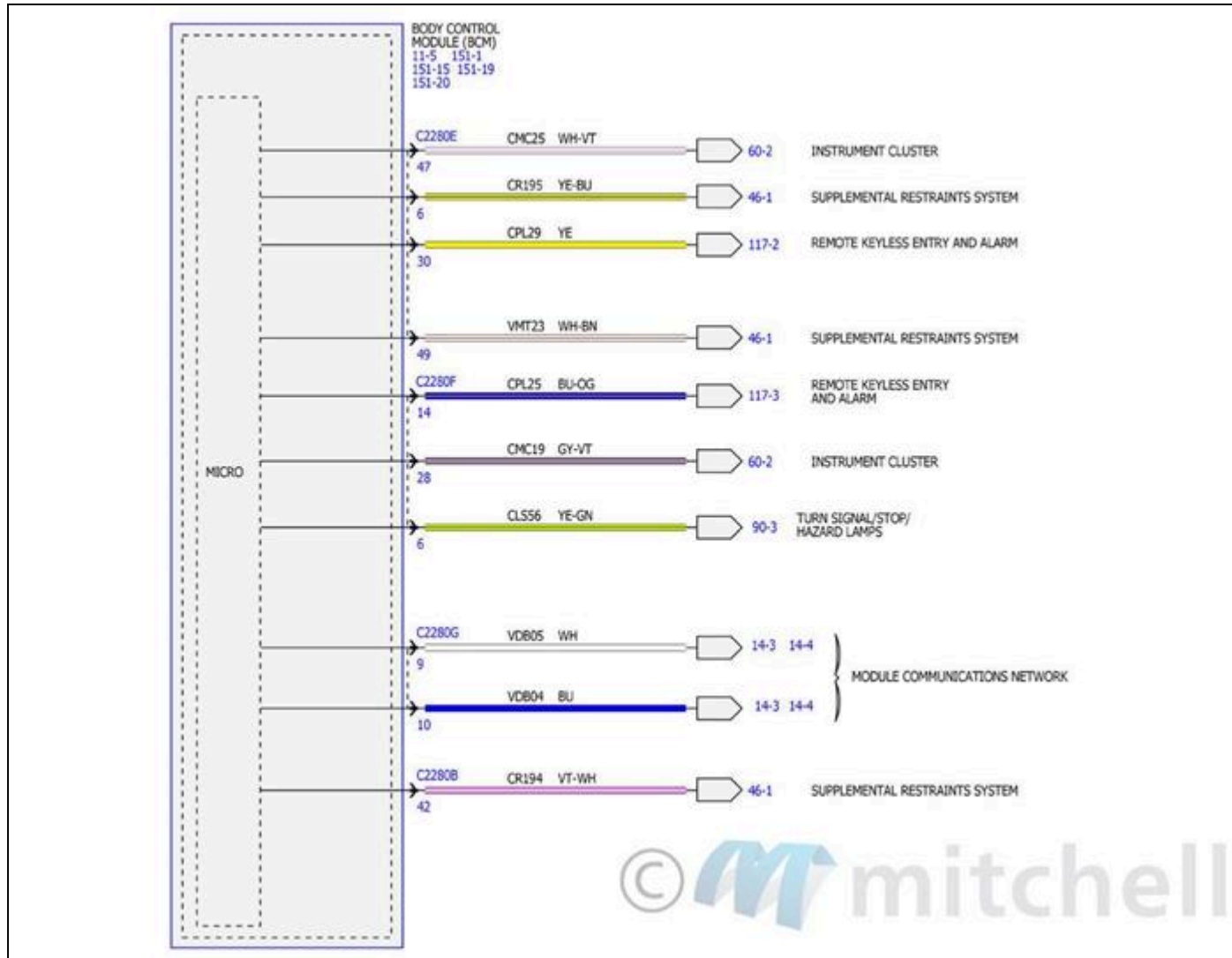

Fig. 163: Power Distribution/BCM Wiring Diagrams (34 Of 34)



POWER MIRRORS

Fig. 164: Power Mirrors Wiring Diagrams (1 Of 4)

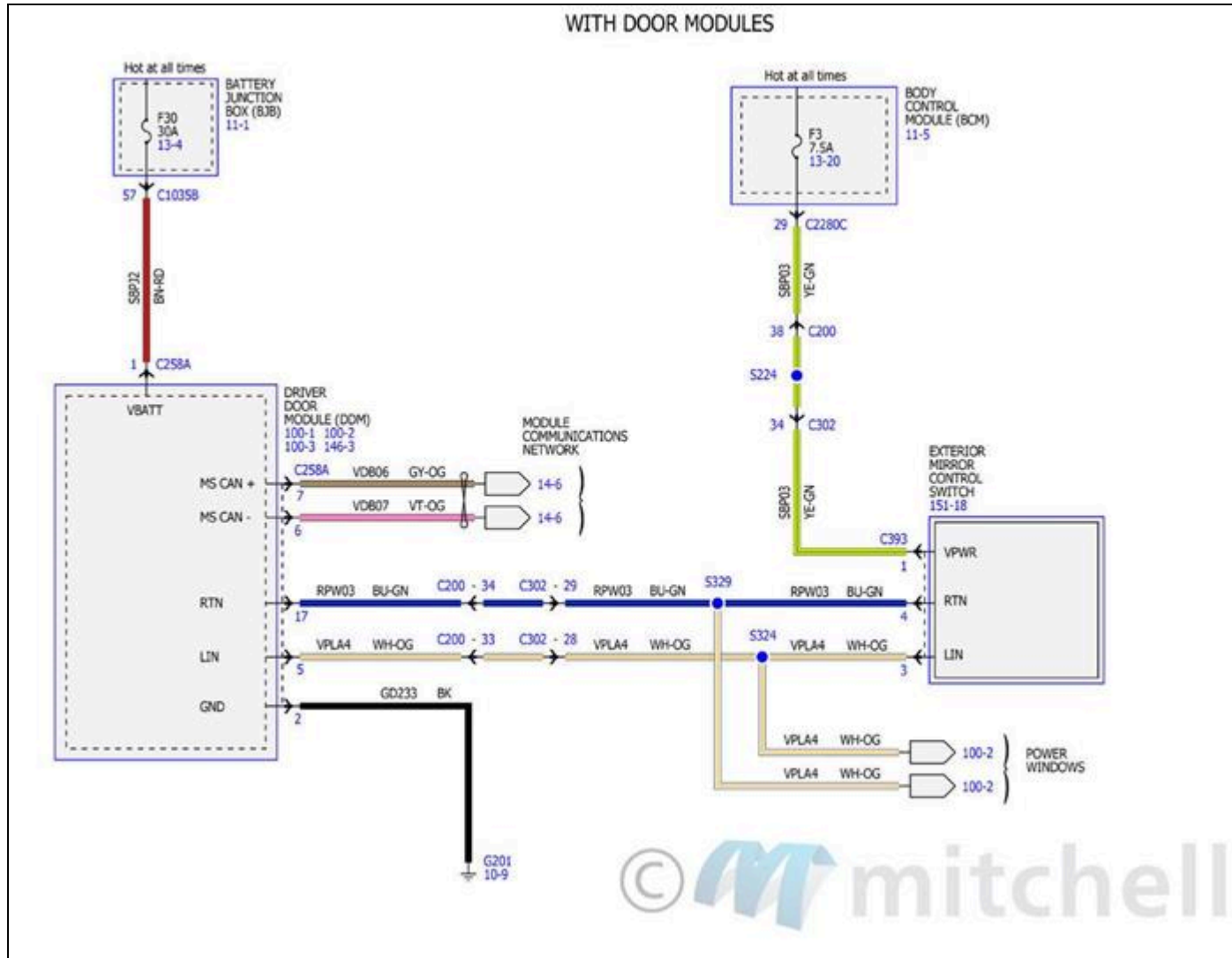

Fig. 165: Power Mirrors Wiring Diagrams (2 Of 4)

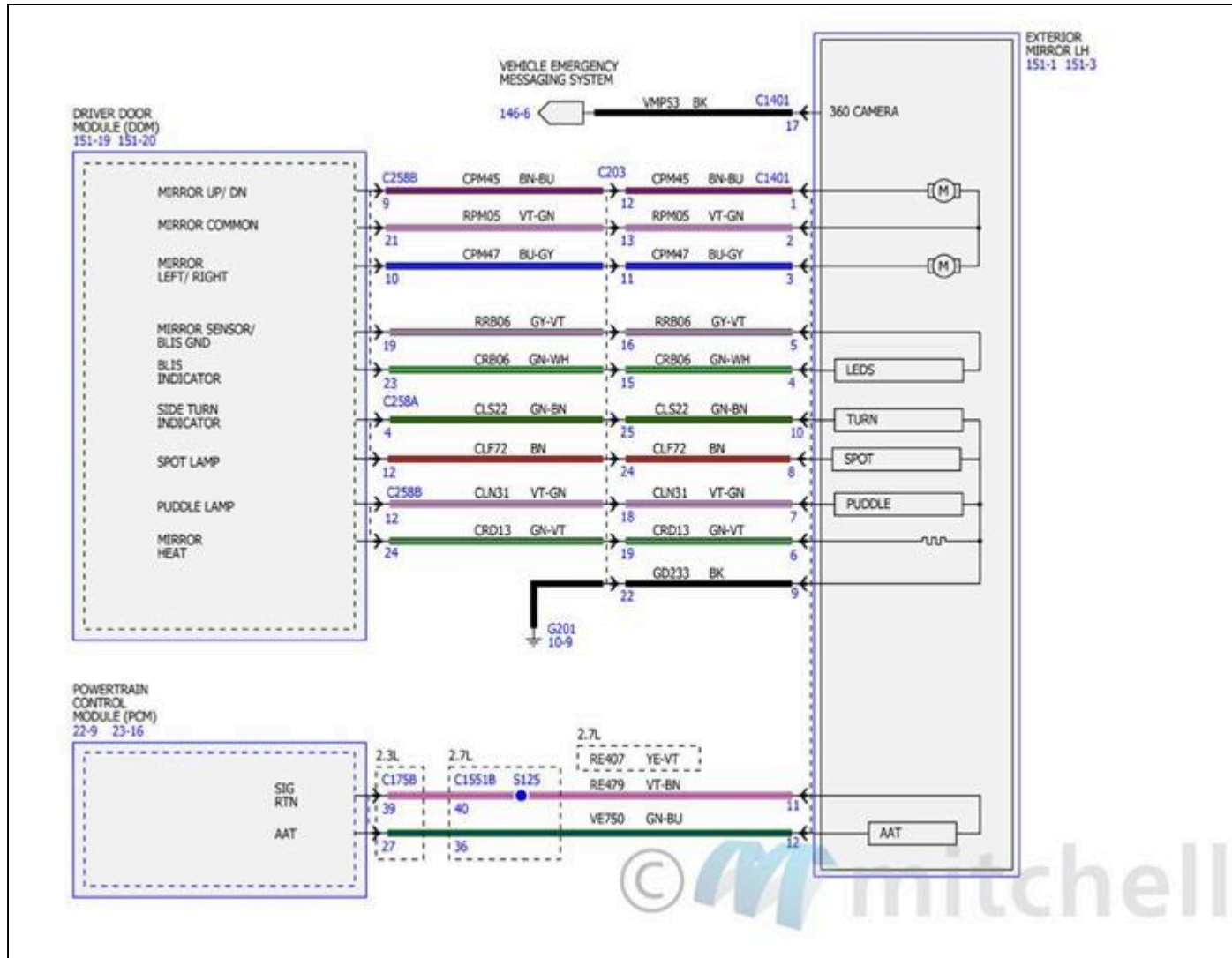

Fig. 166: Power Mirrors Wiring Diagrams (3 Of 4)

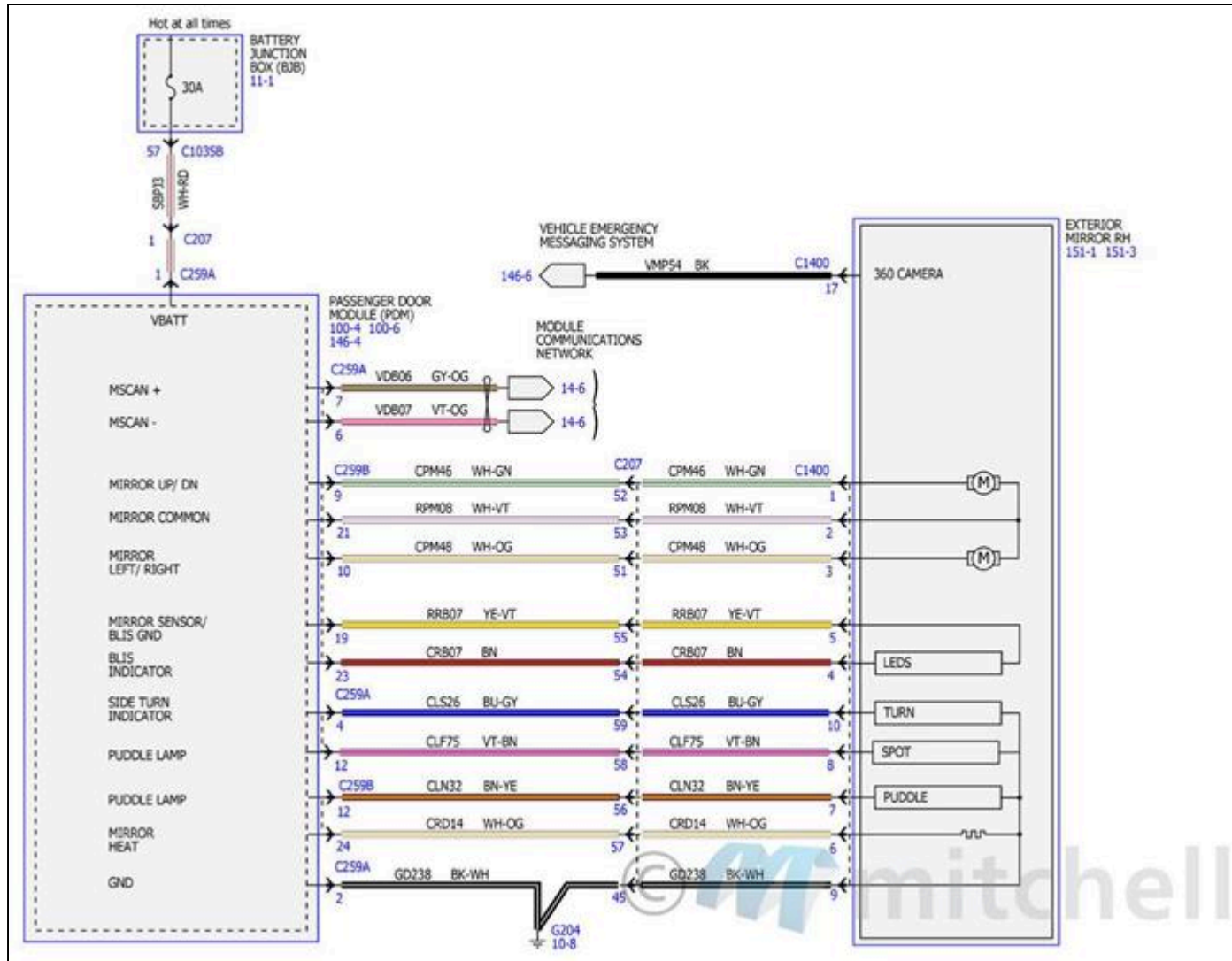
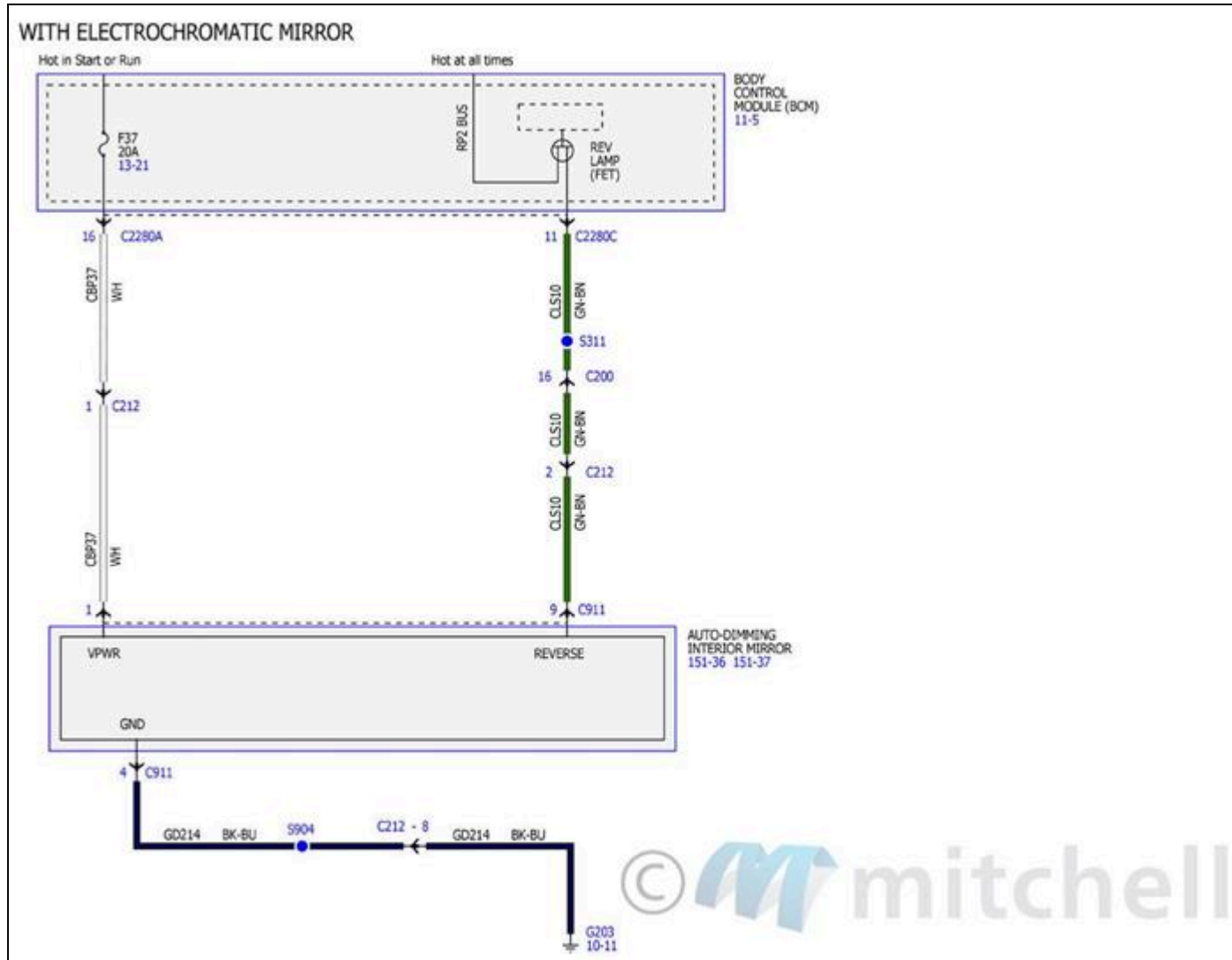

Fig. 167: Power Mirrors Wiring Diagrams (4 Of 4)



POWER SEATS

Fig. 168: Power Seats Wiring Diagrams (1 Of 2)

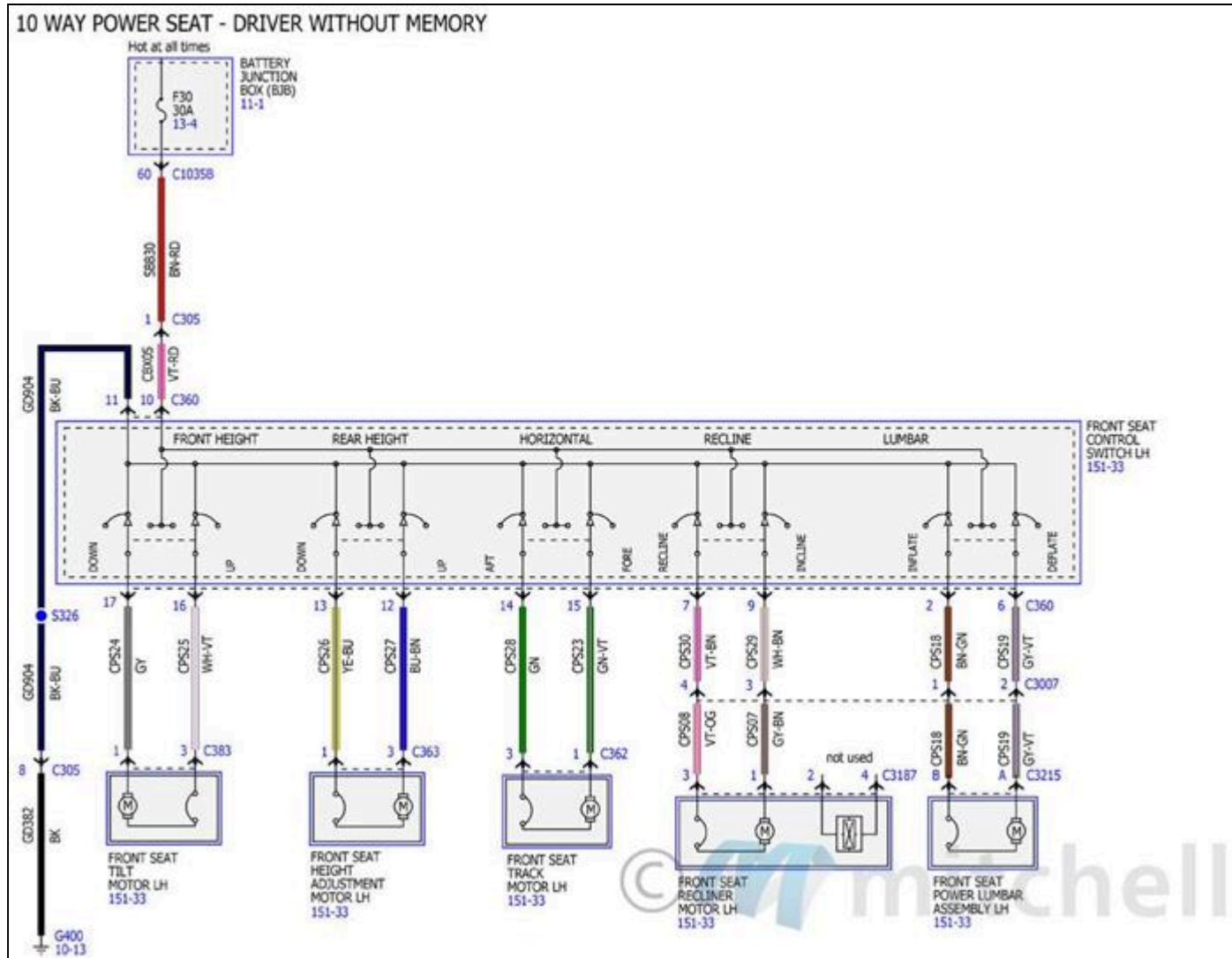
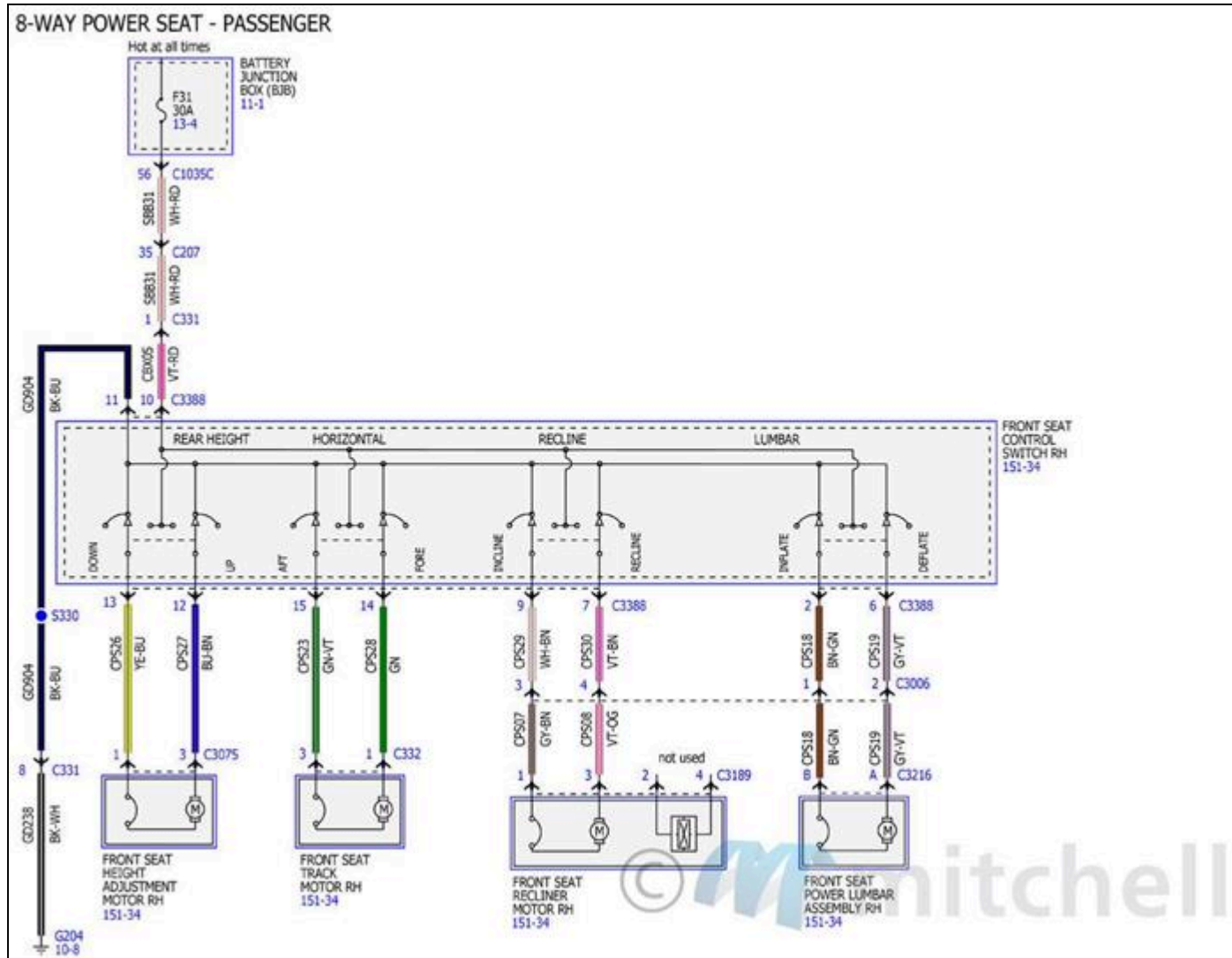
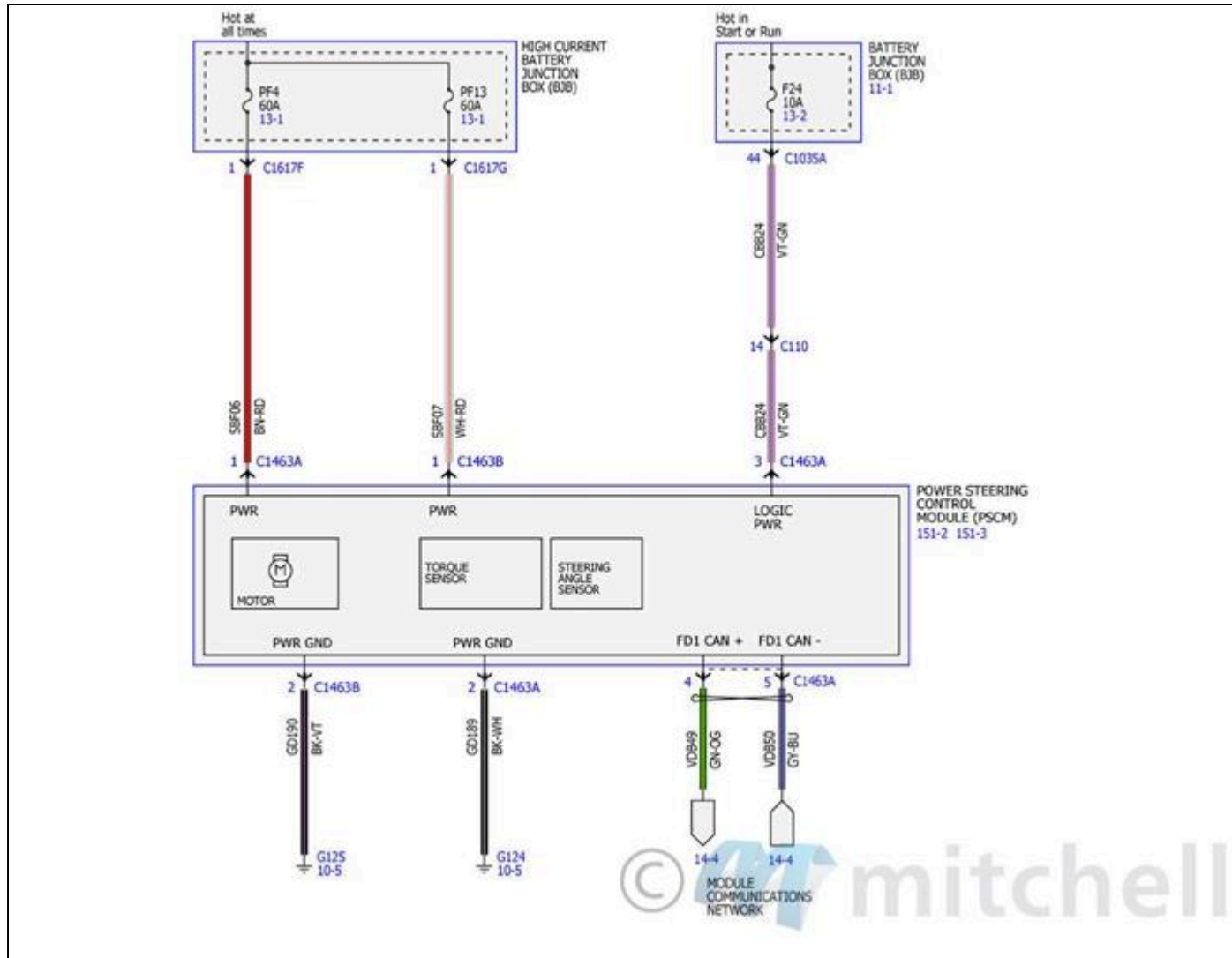

Fig. 169: Power Seats Wiring Diagrams (2 Of 2)



POWER STEERING CONTROLS

Fig. 170: Power Steering Controls Wiring Diagrams



POWER WINDOWS

Fig. 171: Power Windows Wiring Diagrams (1 Of 6)

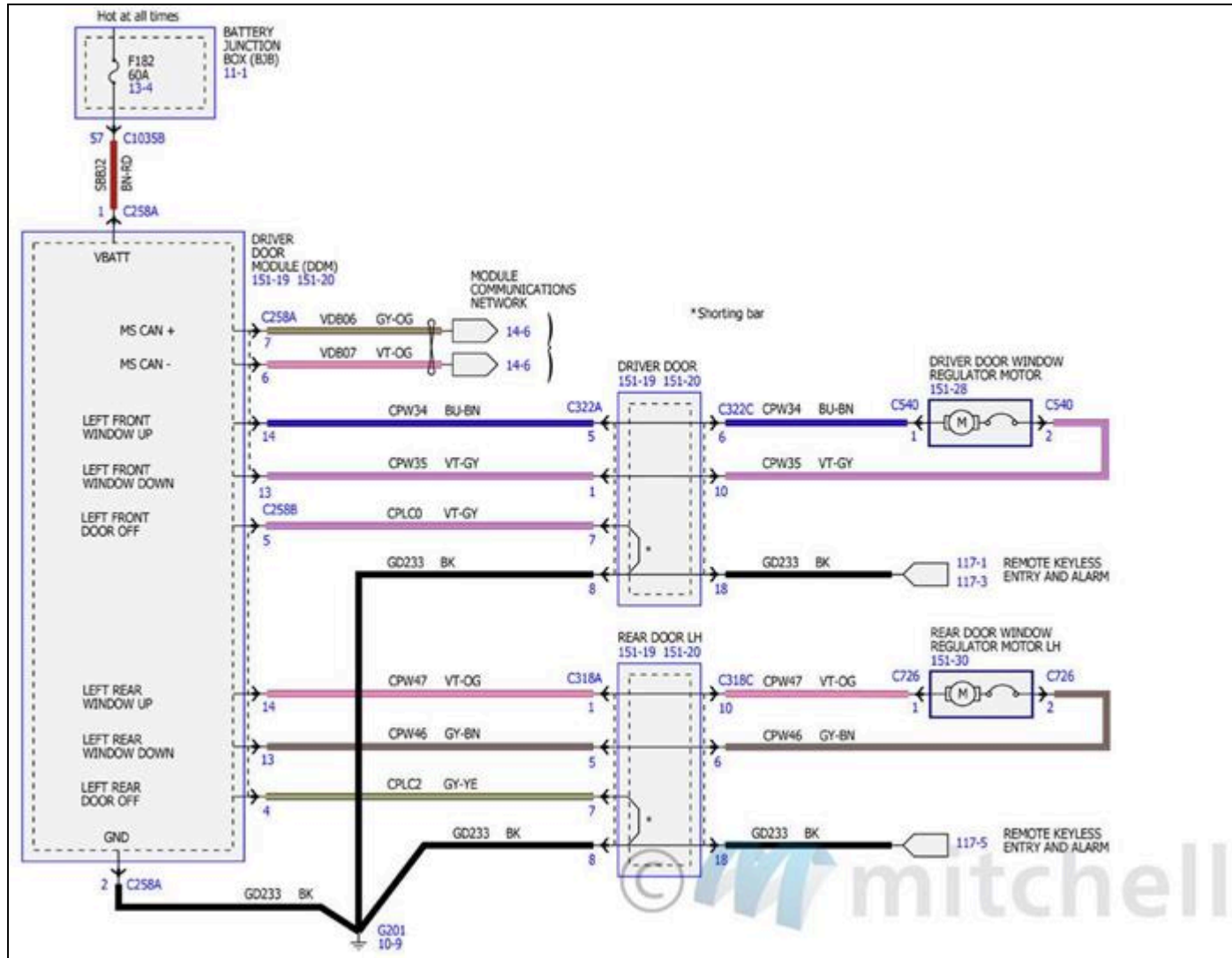

Fig. 172: Power Windows Wiring Diagrams (2 Of 6)

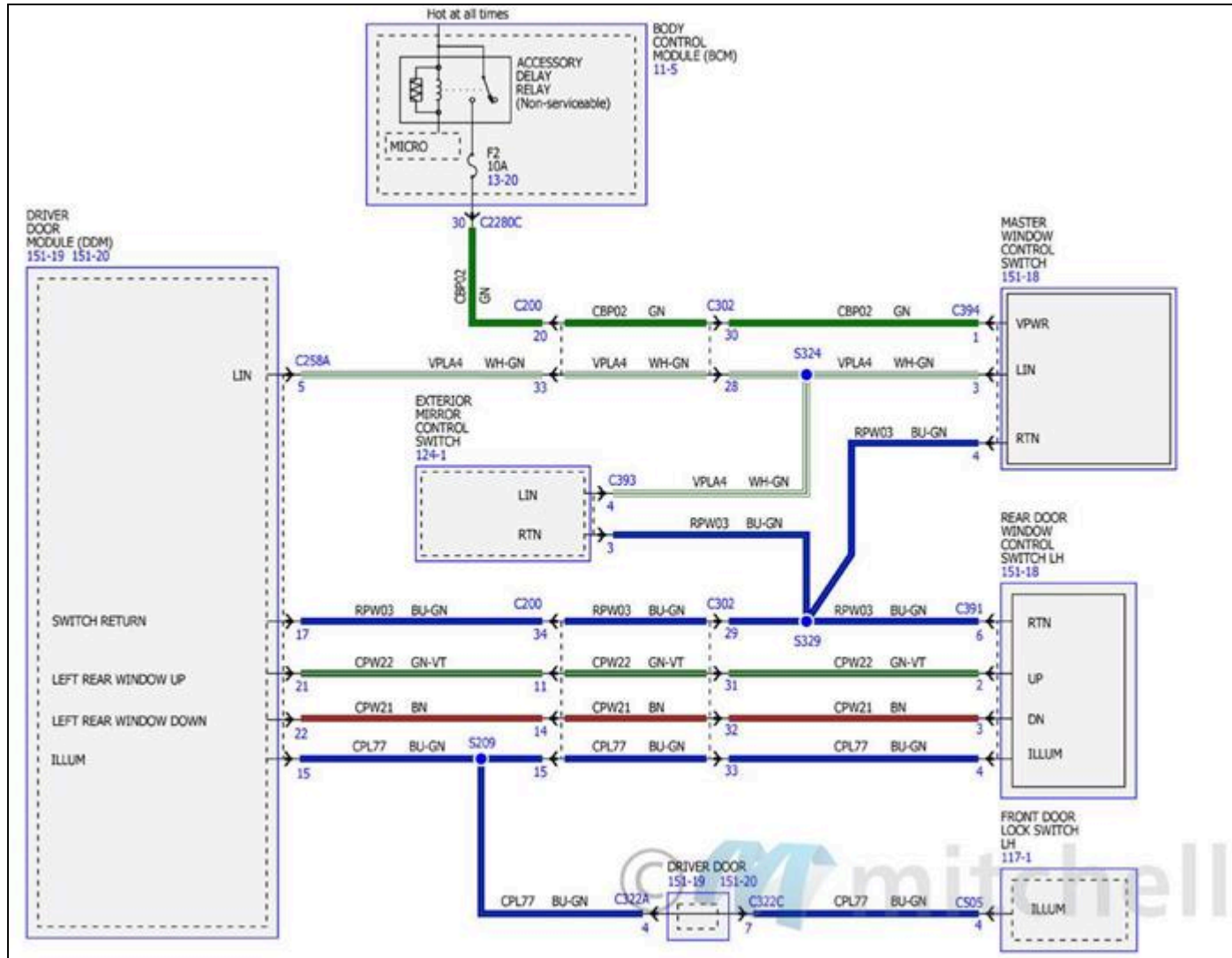

Fig. 173: Power Windows Wiring Diagrams (3 Of 6)

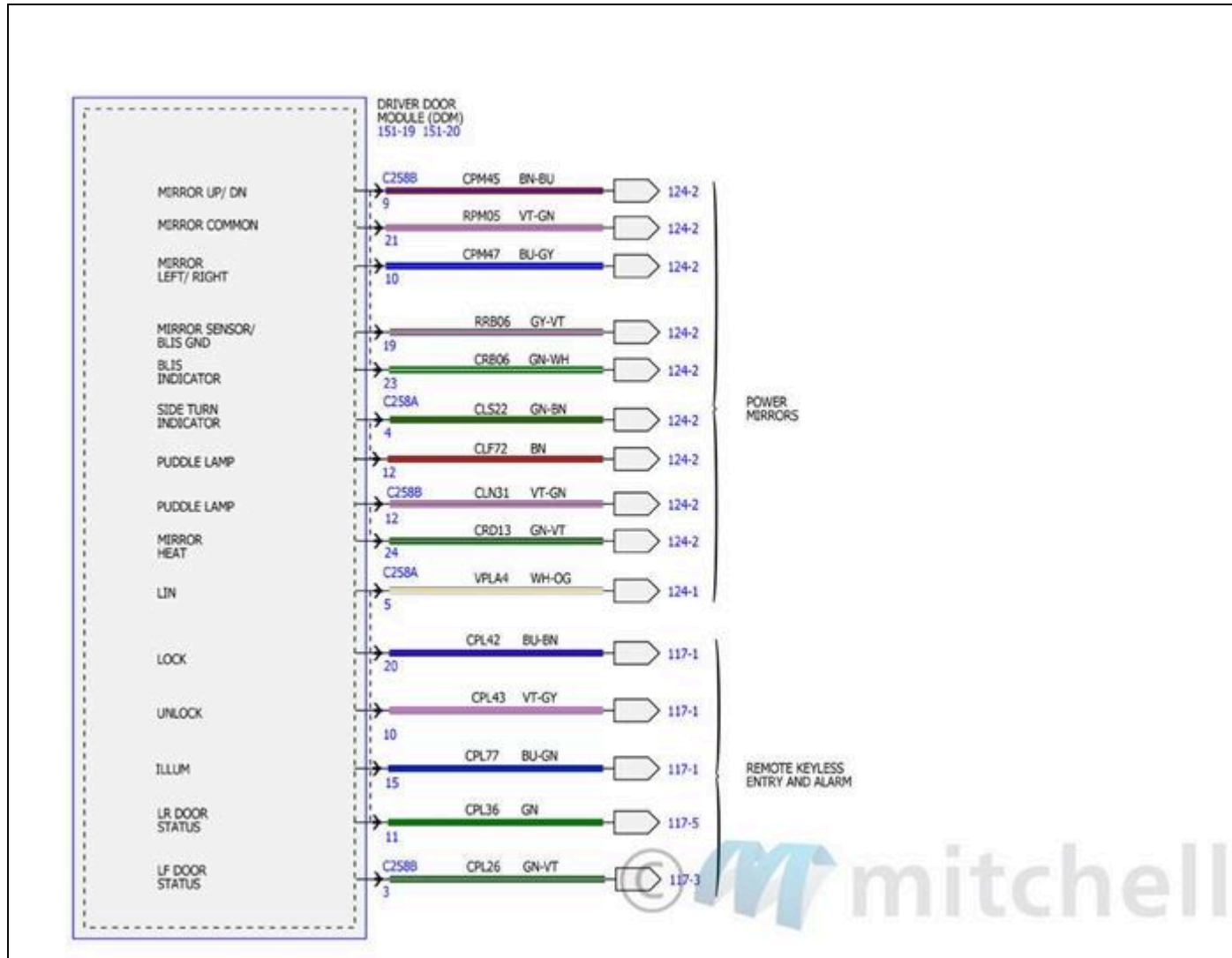

Fig. 174: Power Windows Wiring Diagrams (4 Of 6)

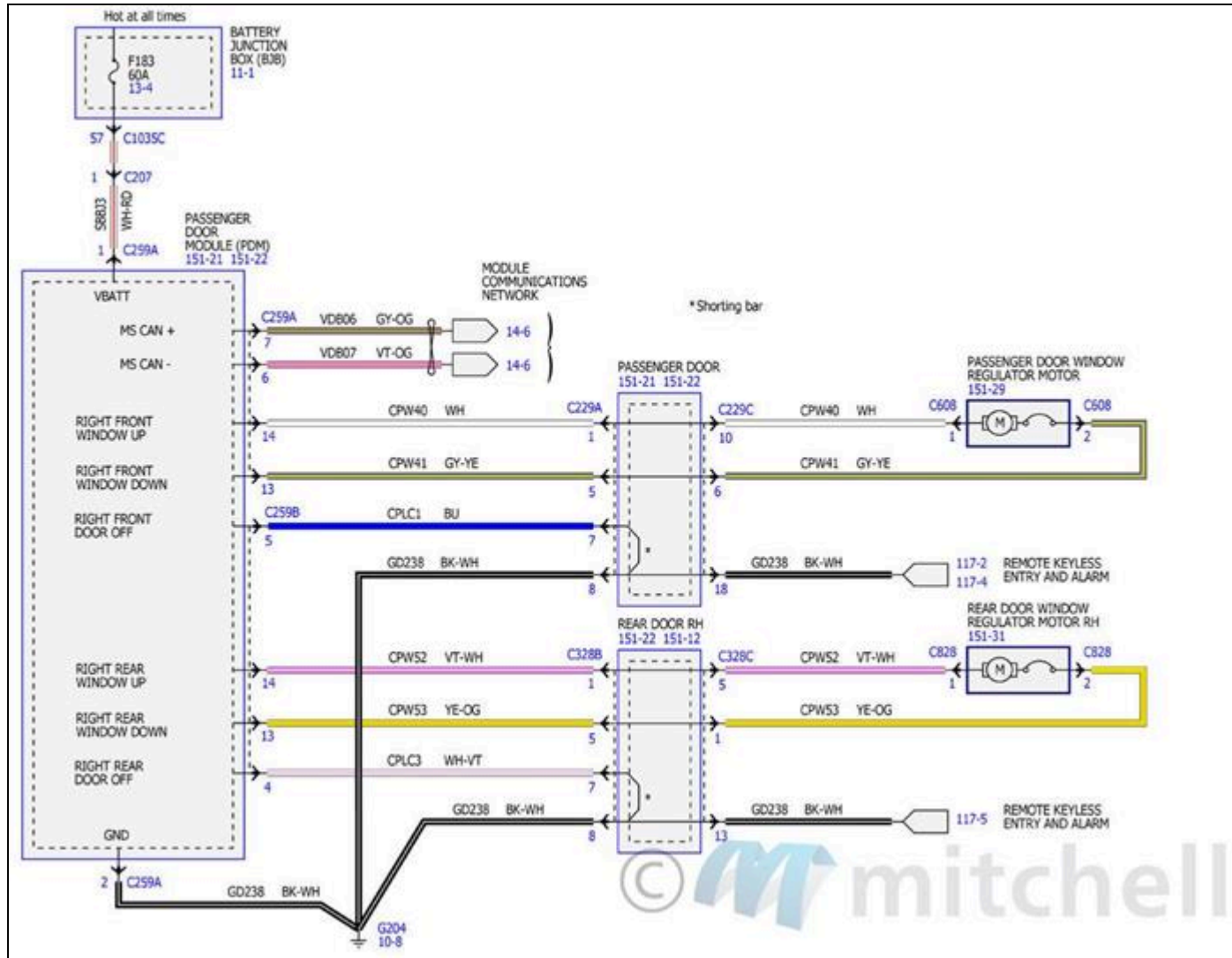

Fig. 175: Power Windows Wiring Diagrams (5 Of 6)

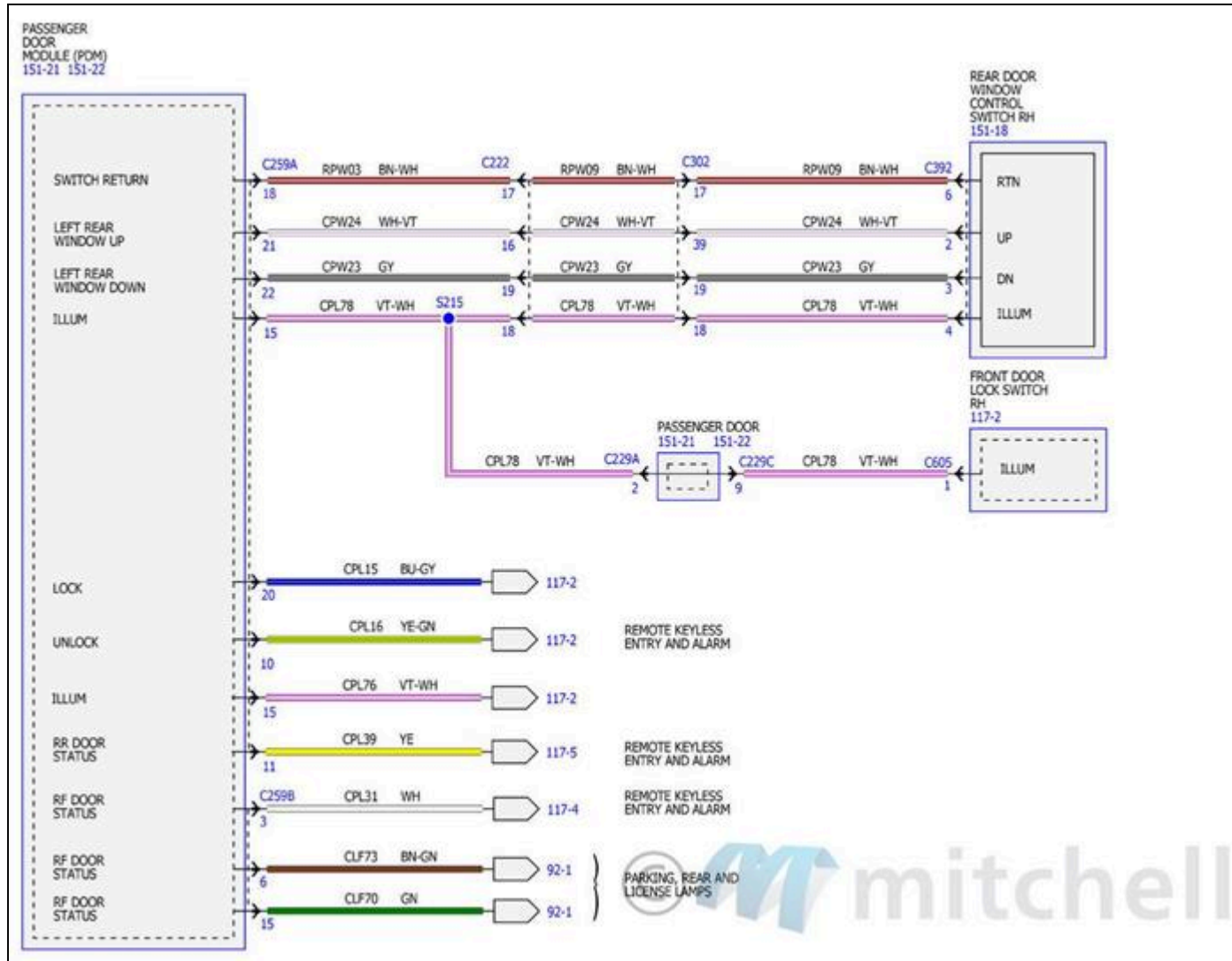
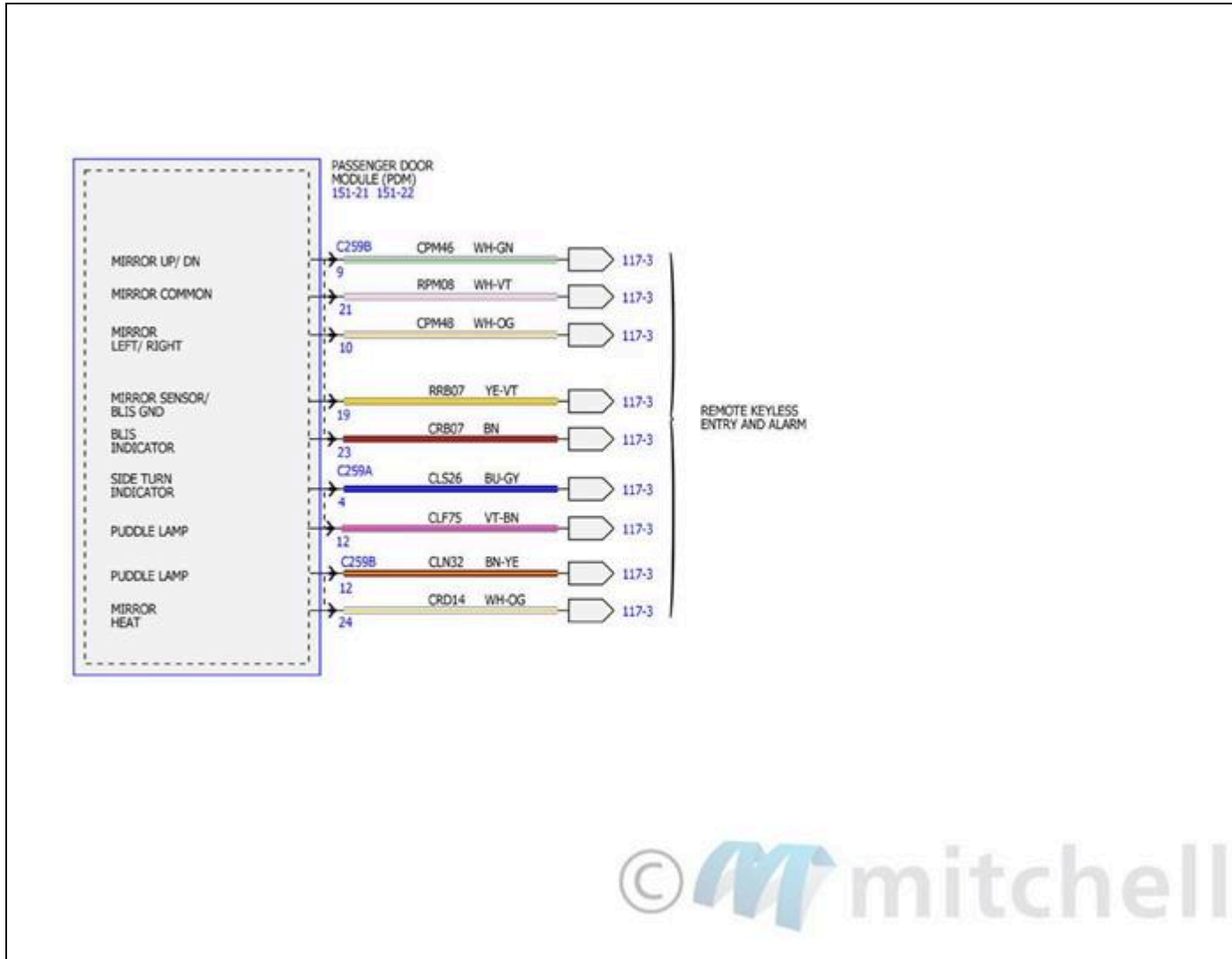

Fig. 176: Power Windows Wiring Diagrams (6 Of 6)



REMOTE KEYLESS ENTRY AND ALARM

Fig. 177: Remote Keyless Entry and Alarm Wiring Diagrams (1 Of 8)

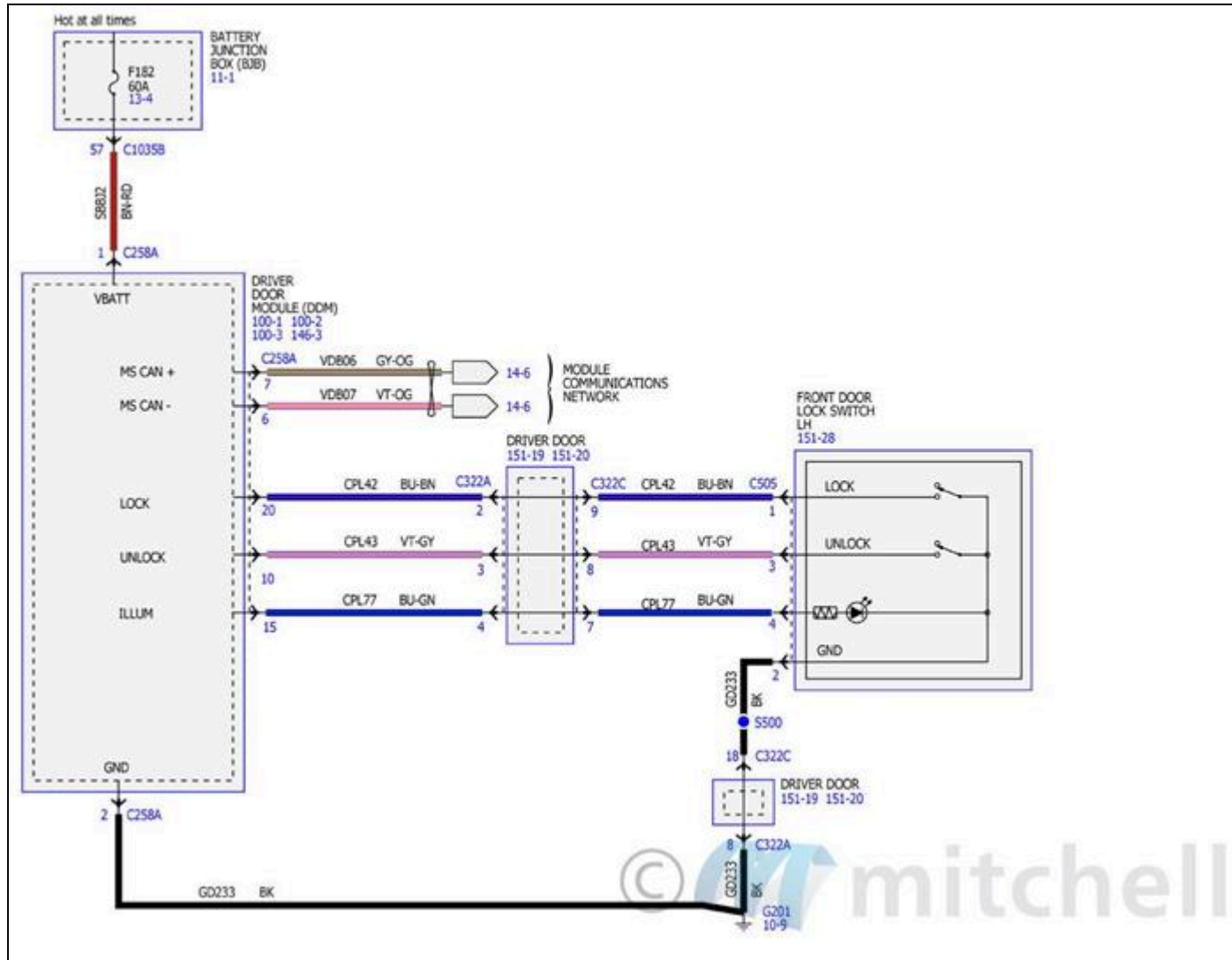

Fig. 178: Remote Keyless Entry and Alarm Wiring Diagrams (2 Of 8)

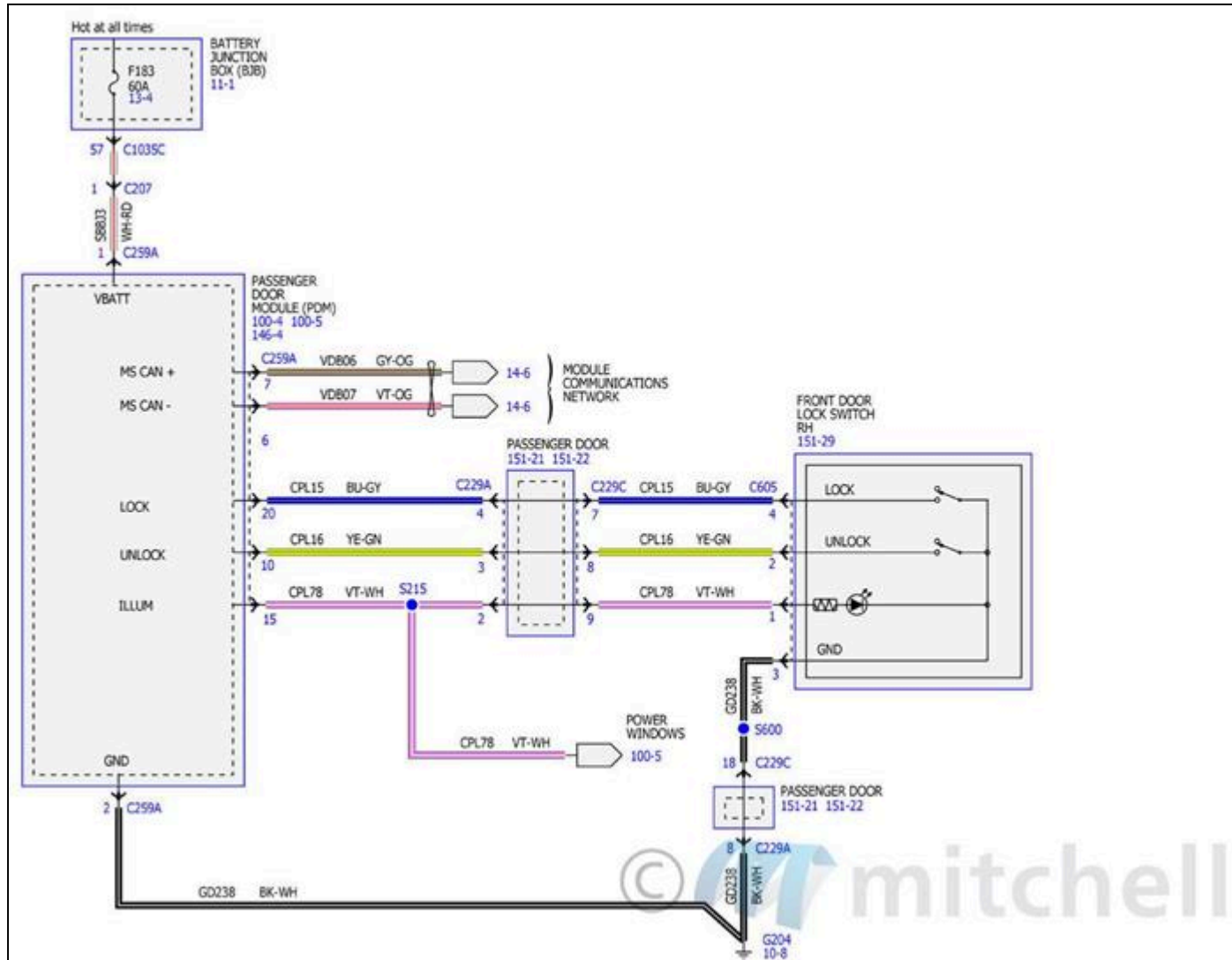

Fig. 180: Remote Keyless Entry and Alarm Wiring Diagrams (4 Of 8)

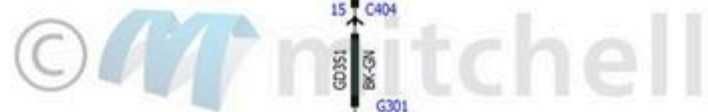
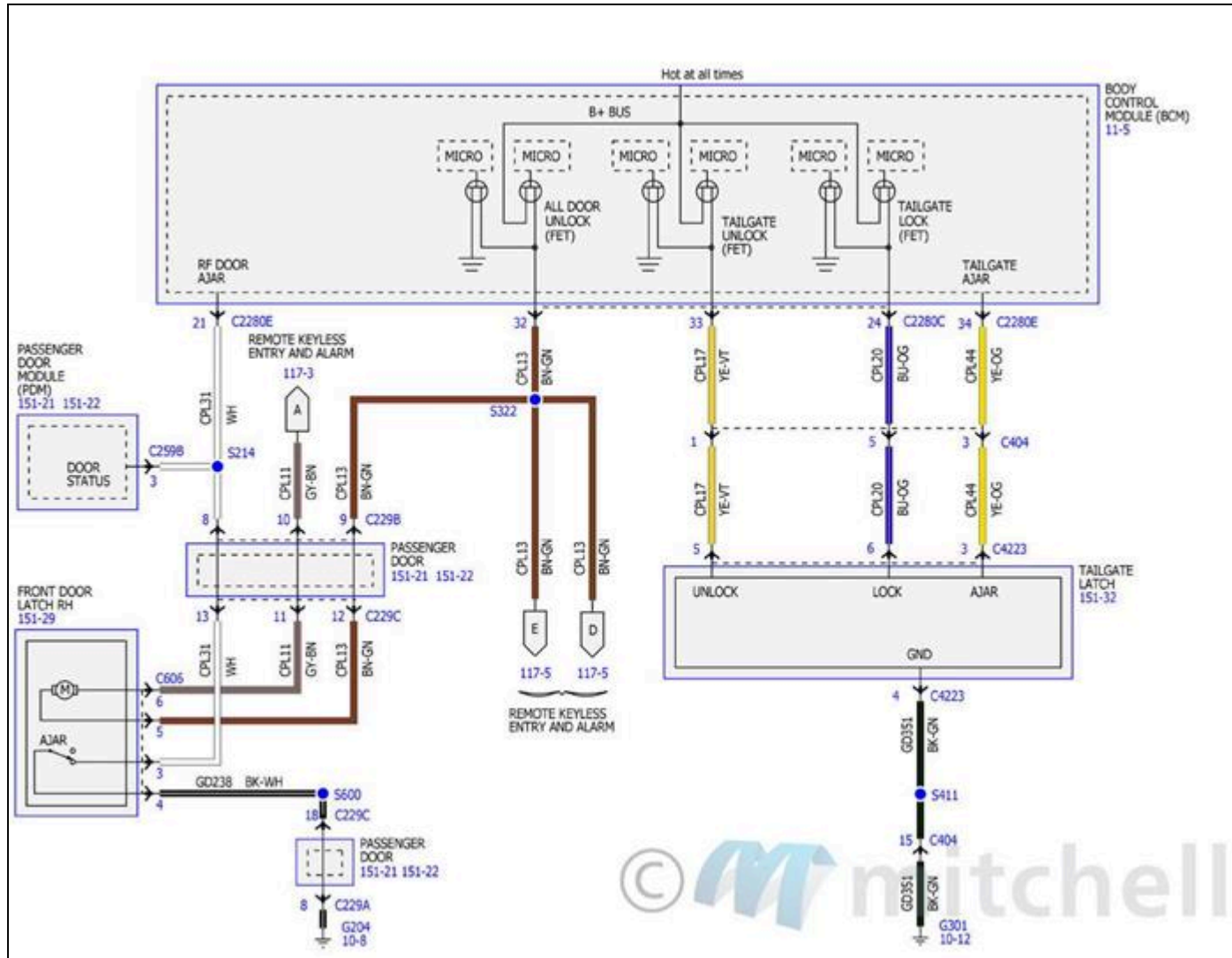

Fig. 182: Remote Keyless Entry and Alarm Wiring Diagrams (6 Of 8)

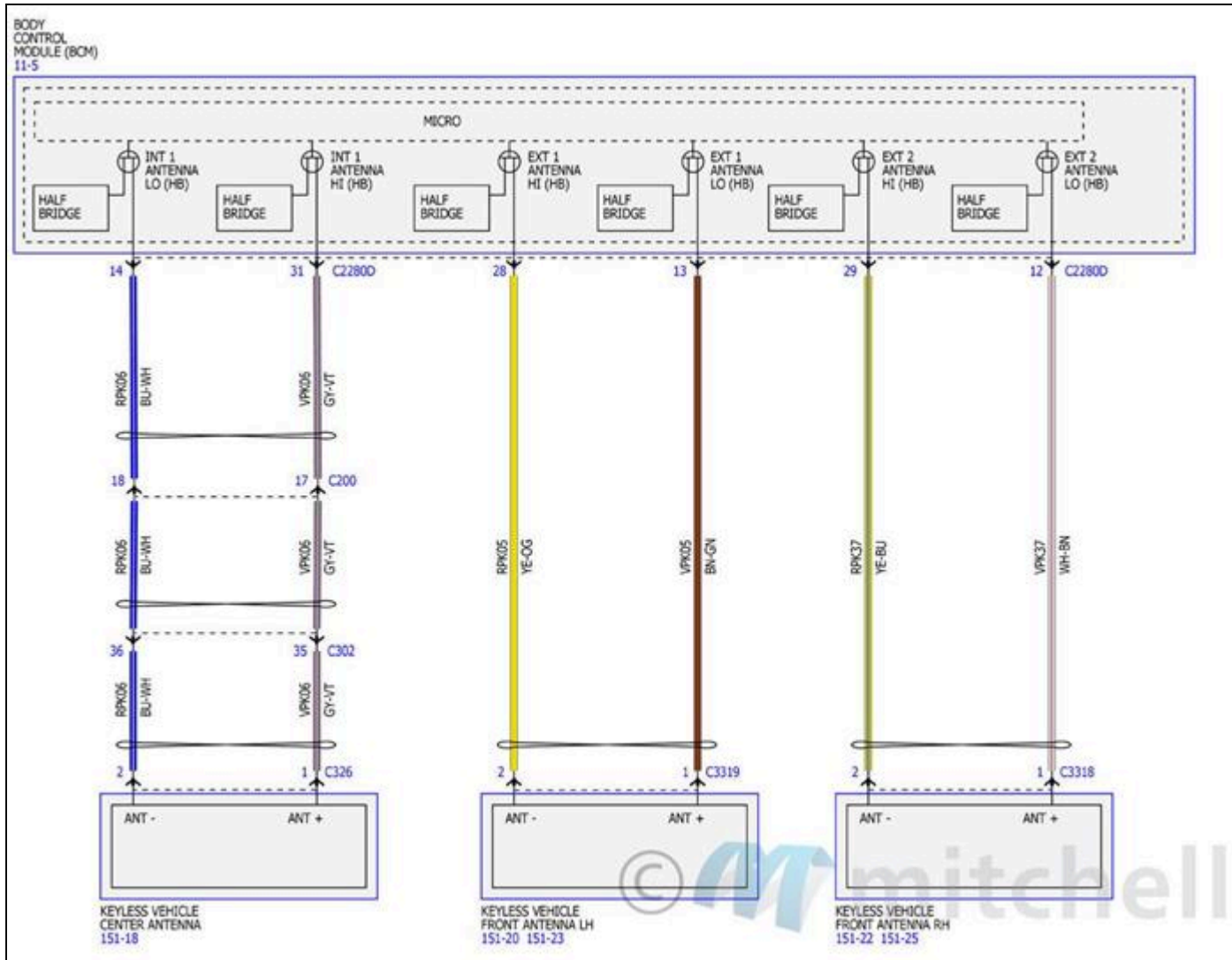

Fig. 183: Remote Keyless Entry and Alarm Wiring Diagrams (7 Of 8)

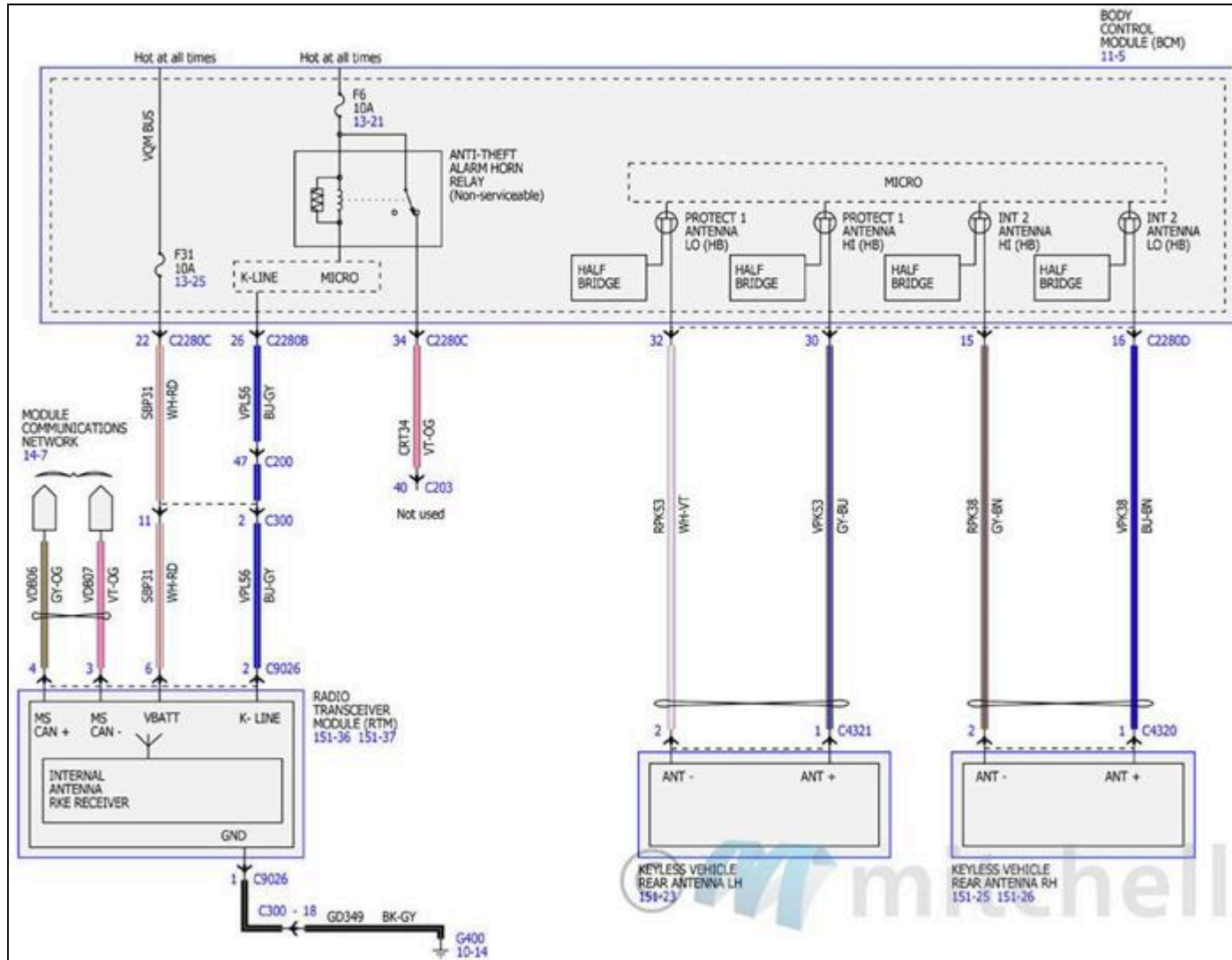
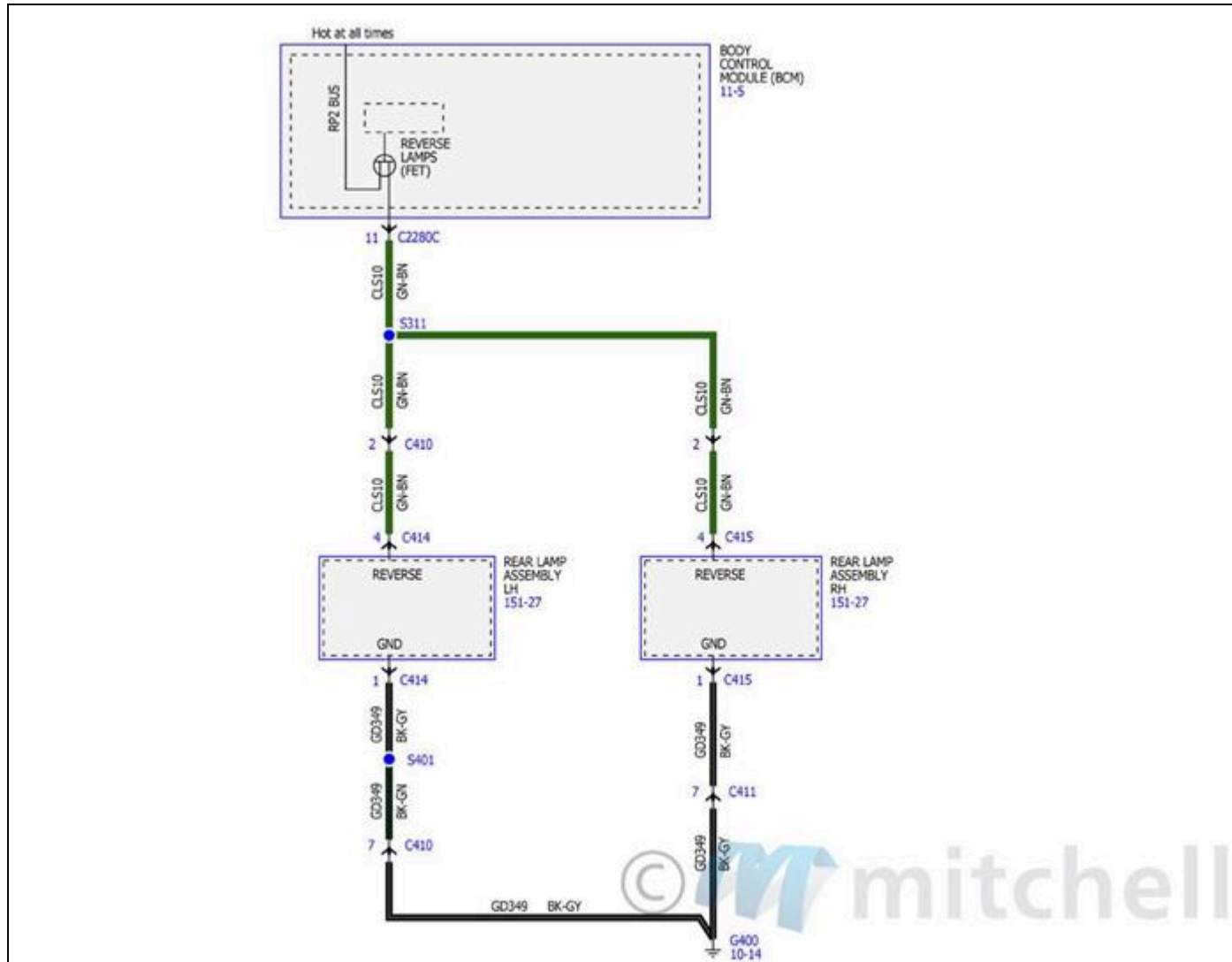
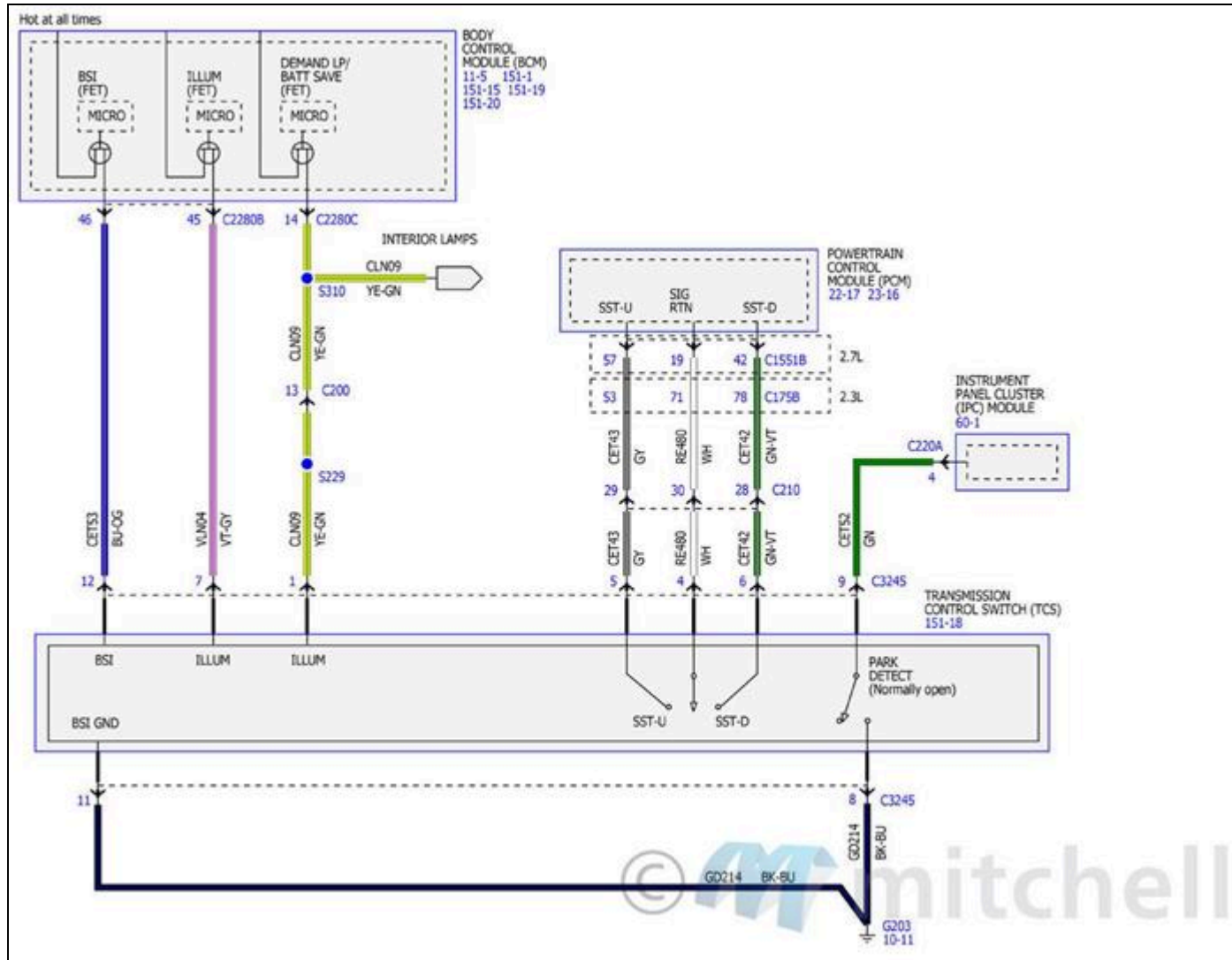

Fig. 185: Reversing Lamps Wiring Diagram



SHIFT INTERLOCK

Fig. 186: Shift Interlock Wiring Diagram



STARTING SYSTEM

Fig. 187: Starting System Wiring Diagrams (1 Of 2)

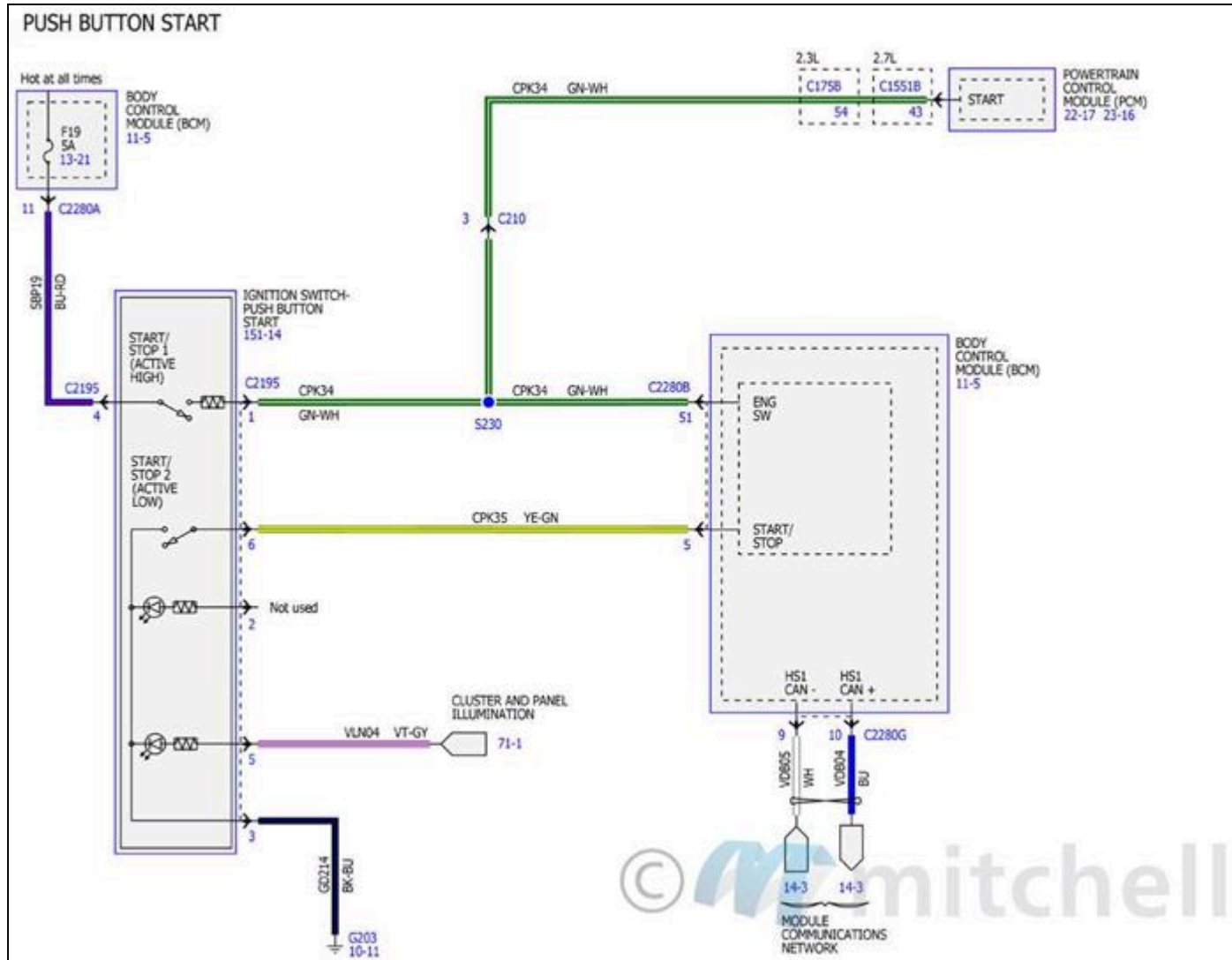
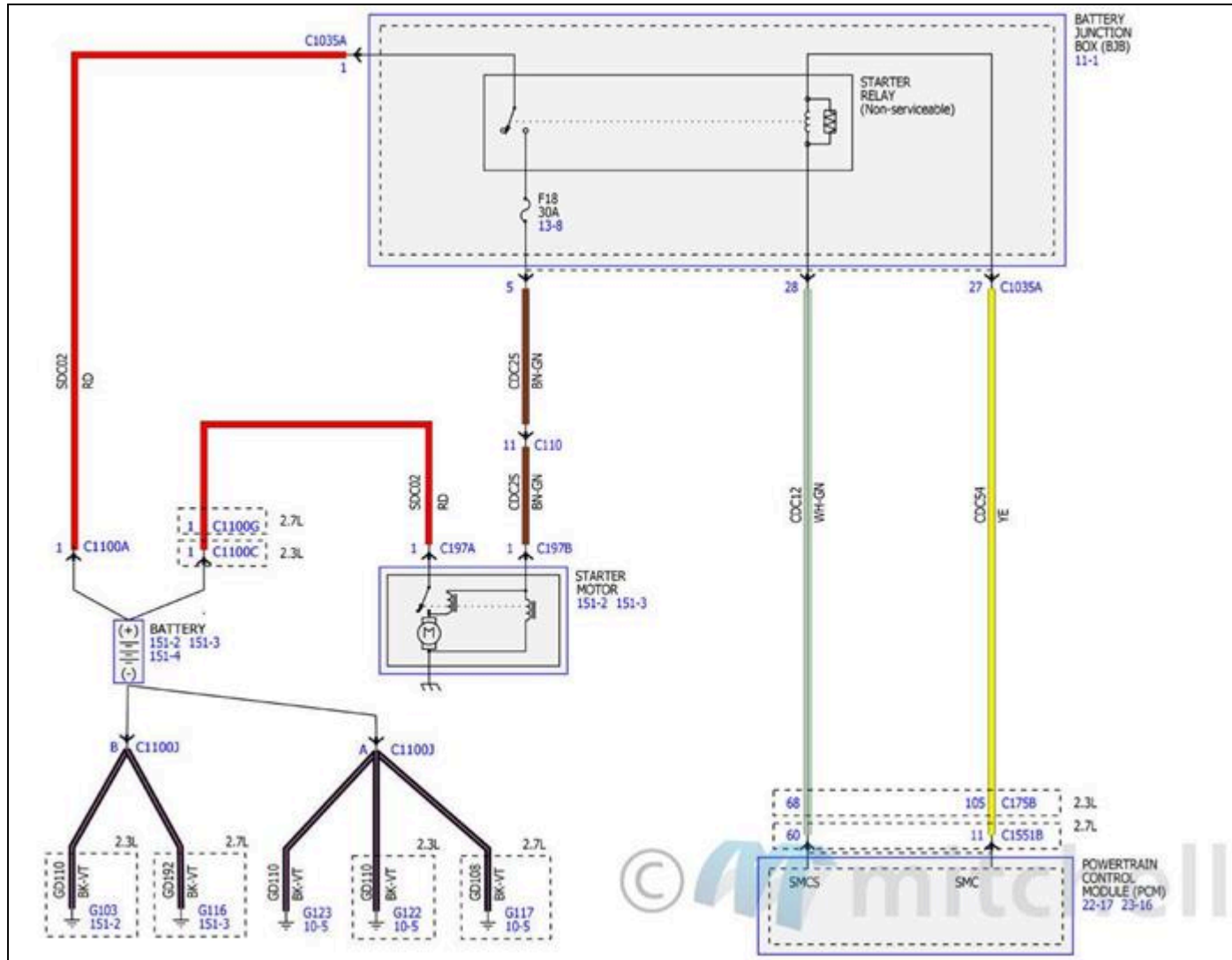

Fig. 188: Starting System Wiring Diagrams (2 Of 2)



SUPPLEMENTAL RESTRAINT SYSTEM

Fig. 189: Supplemental Restraint System Wiring Diagrams (1 Of 8)

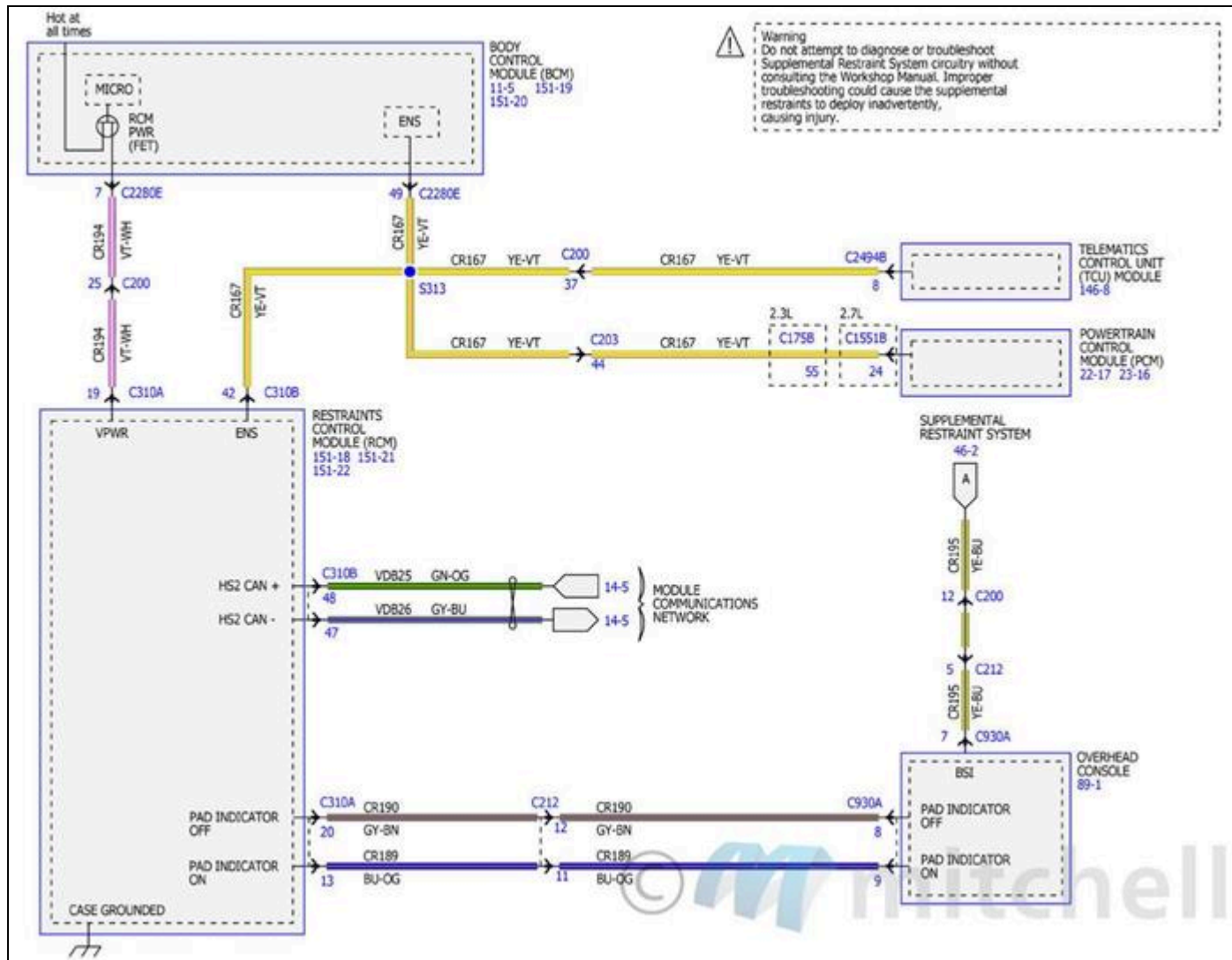

Fig. 190: Supplemental Restraint System Wiring Diagrams (2 Of 8)

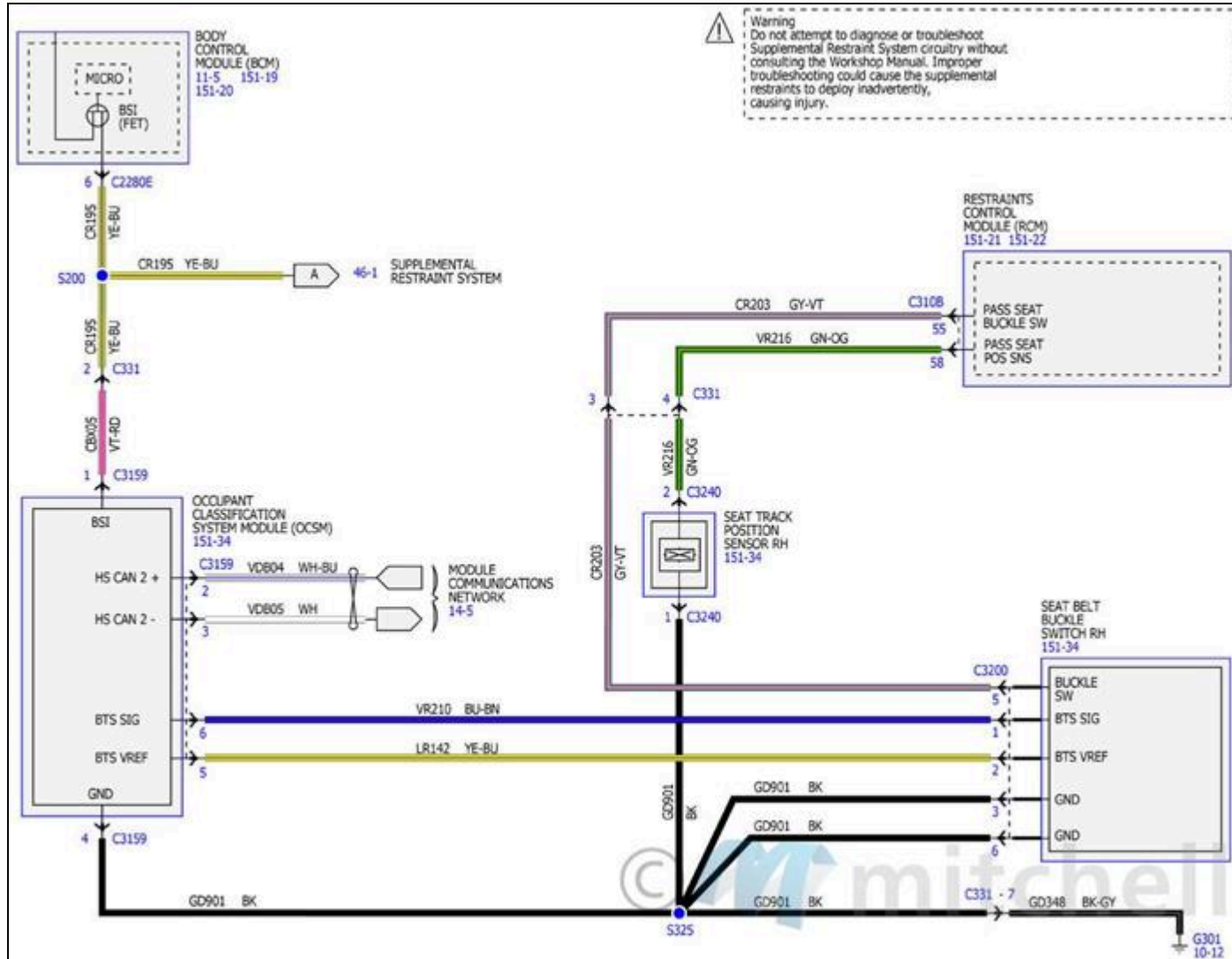

Fig. 191: Diagramas de cableado del sistema de retención suplementario (3 de 8)

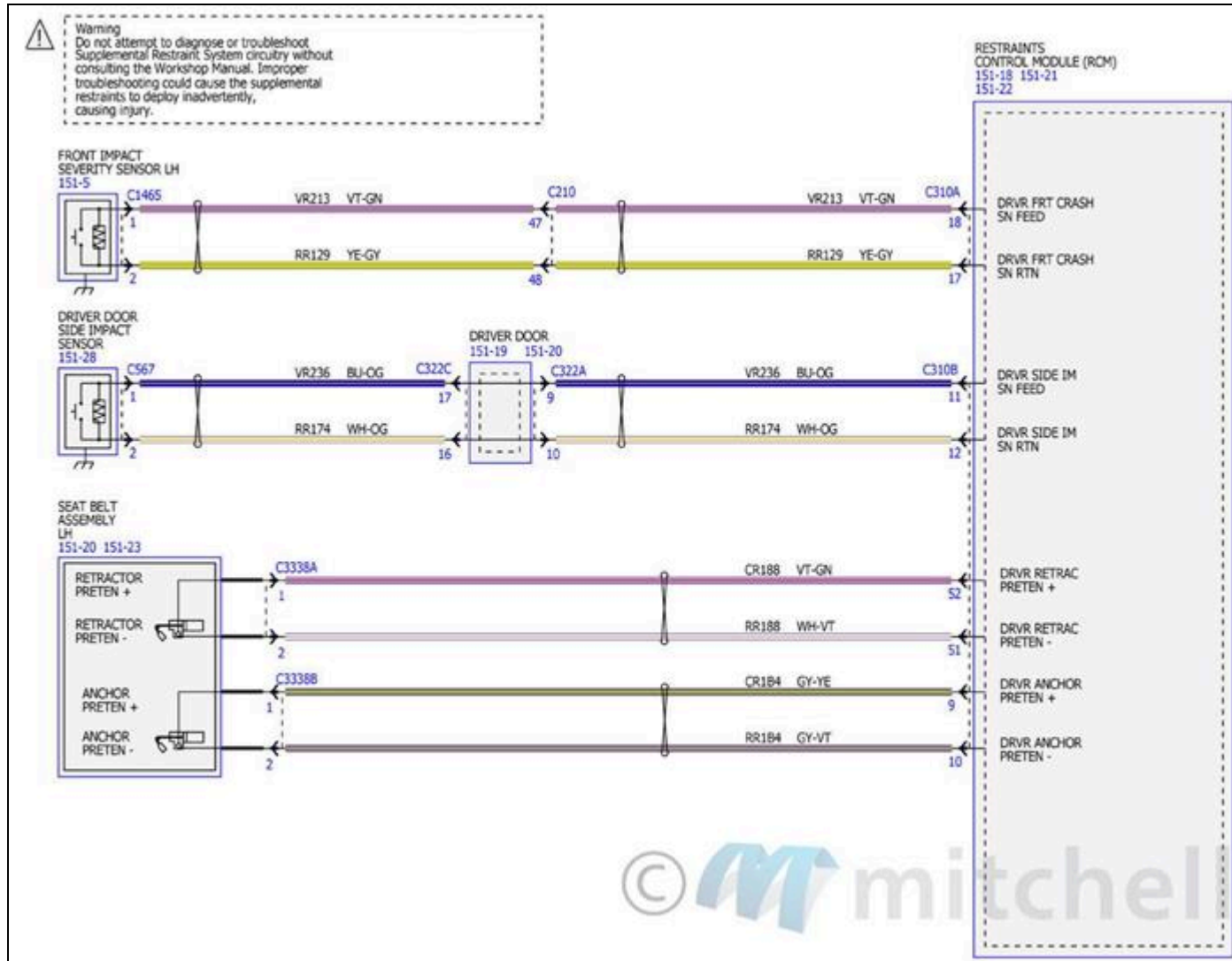

Fig. 192: Diagramas de cableado del sistema de retención suplementario (4 de 8)

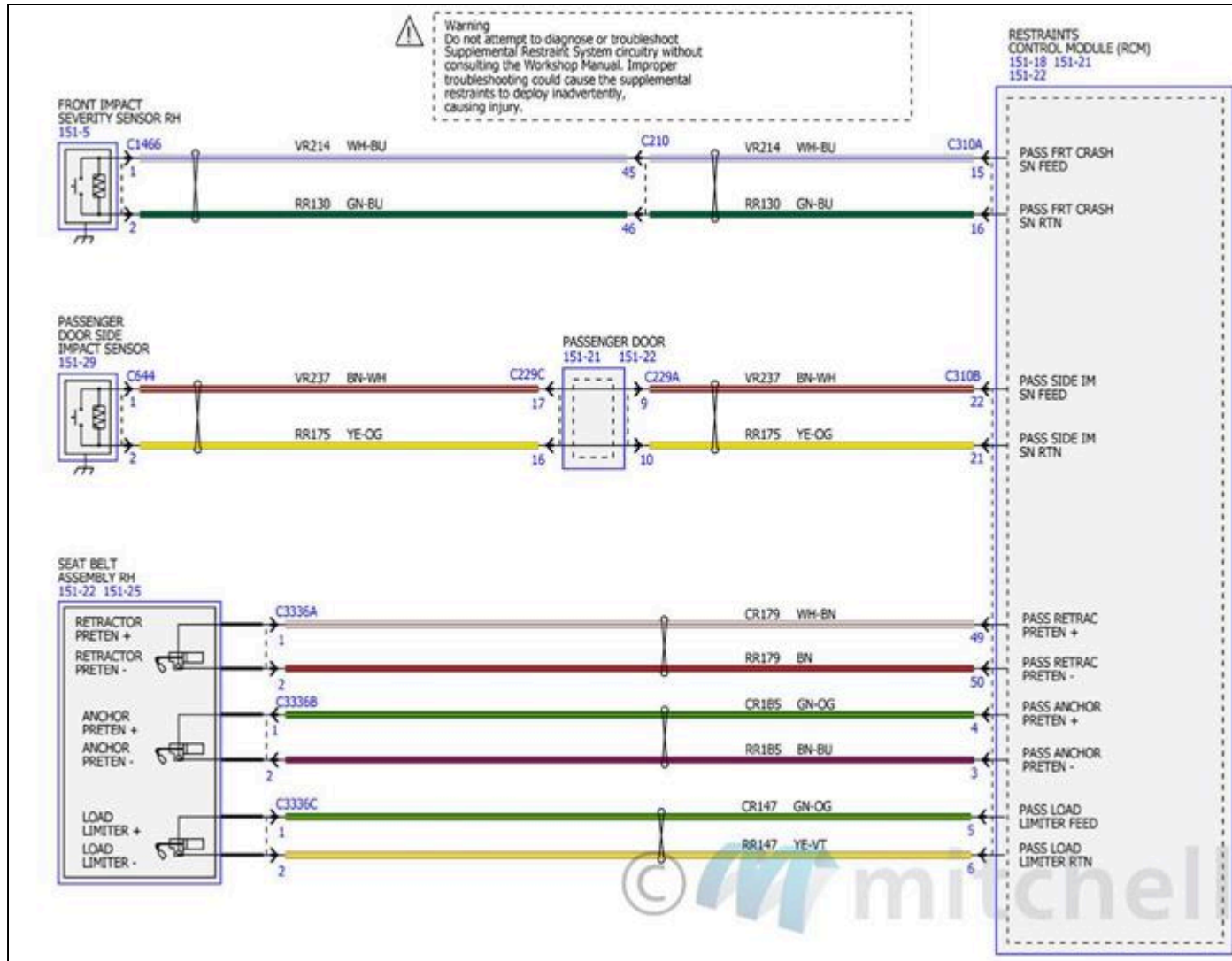

Fig. 193: Diagramas de cableado del sistema de retención suplementario (5 de 8)

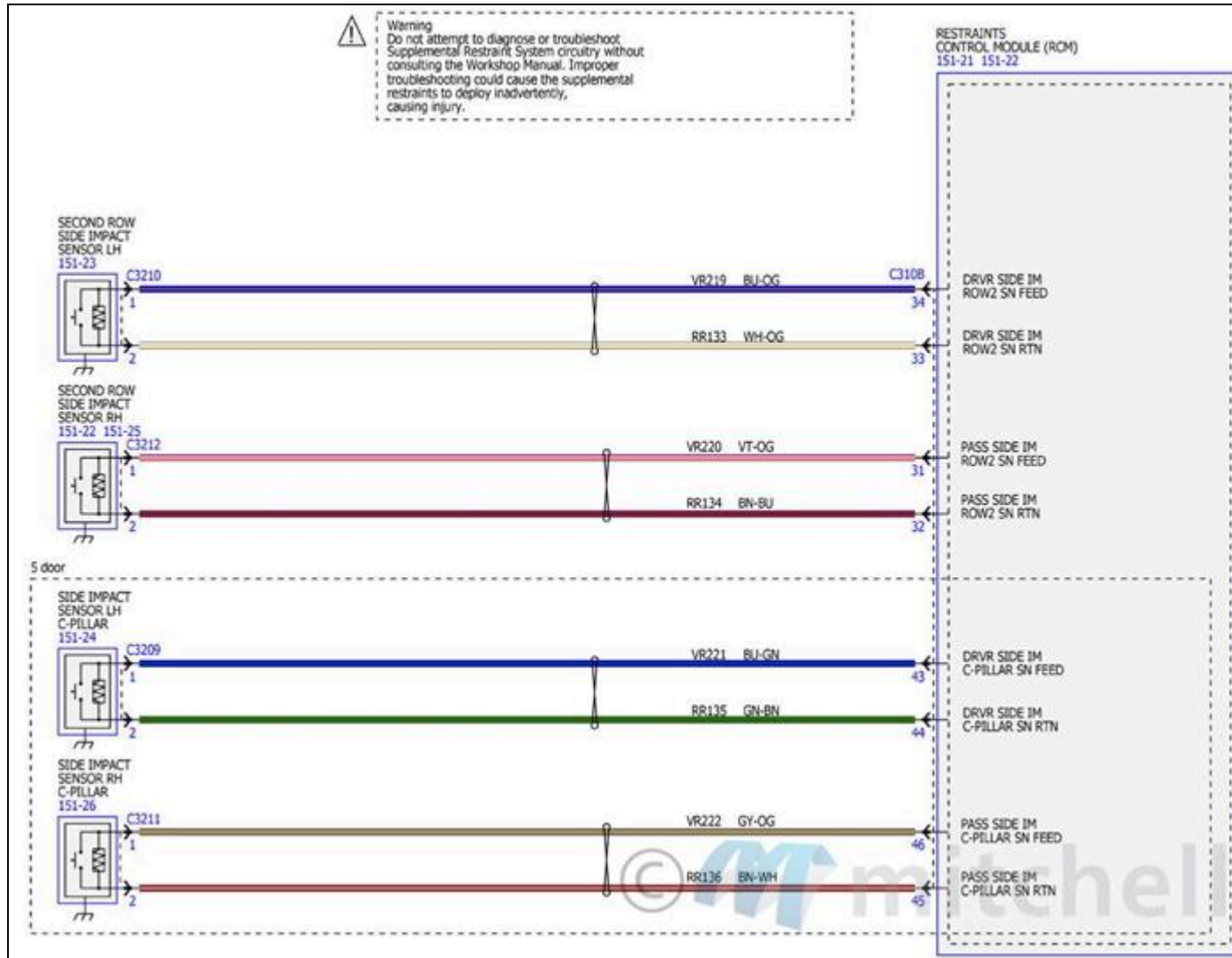

Fig. 194: Diagramas de cableado del sistema de retención suplementario (6 de 8)

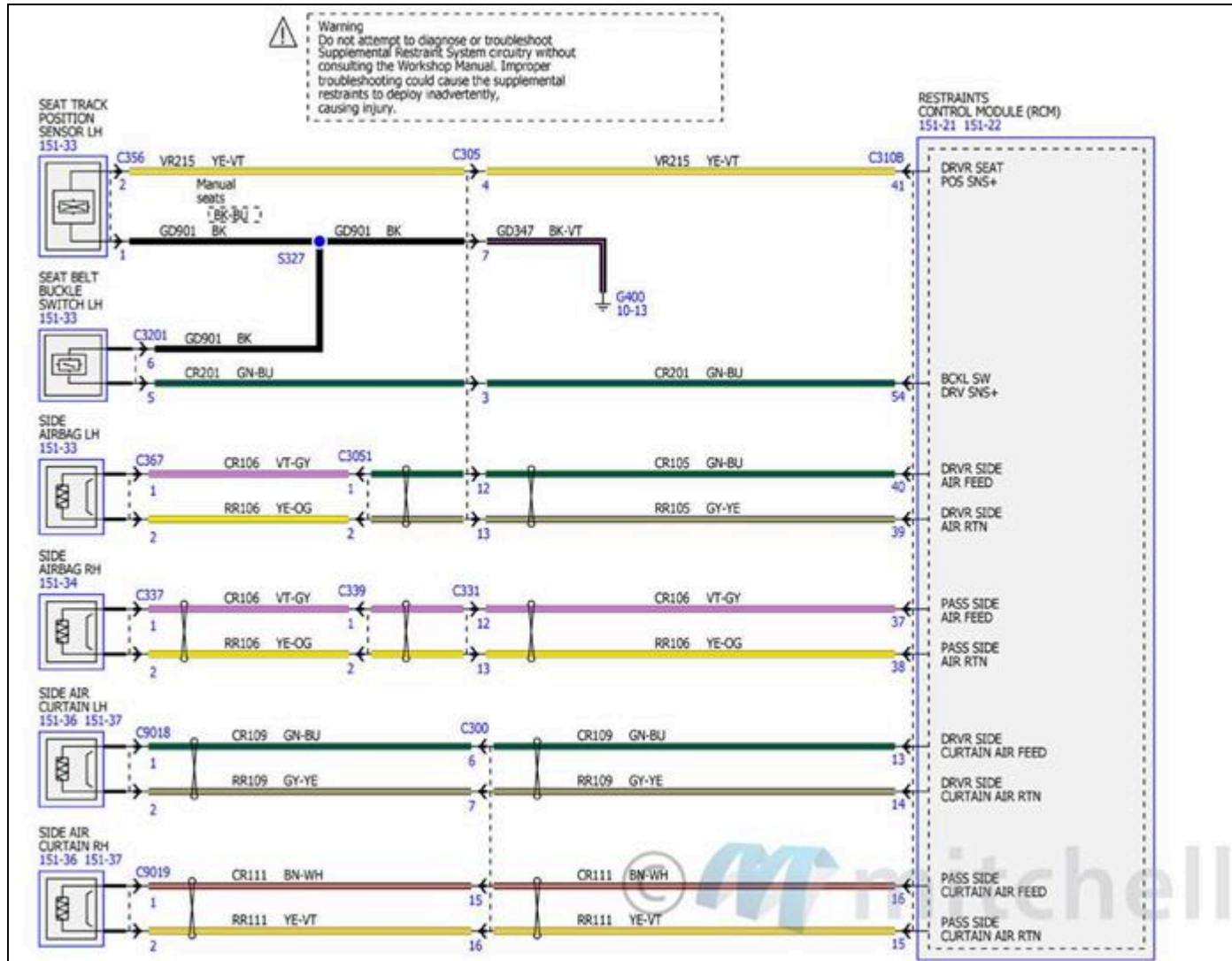

Fig. 195: Diagramas de cableado del sistema de retención suplementario (7 de 8)

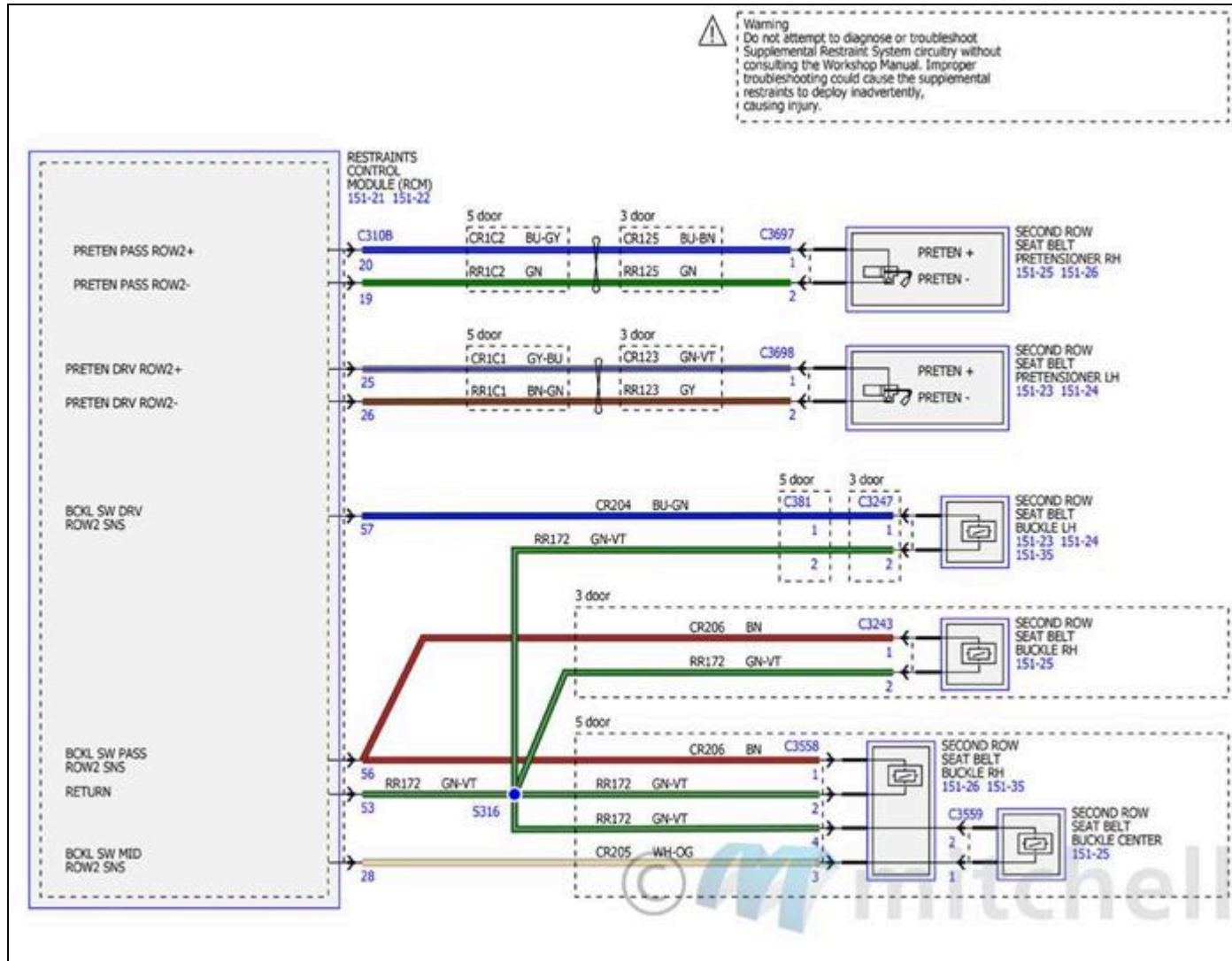
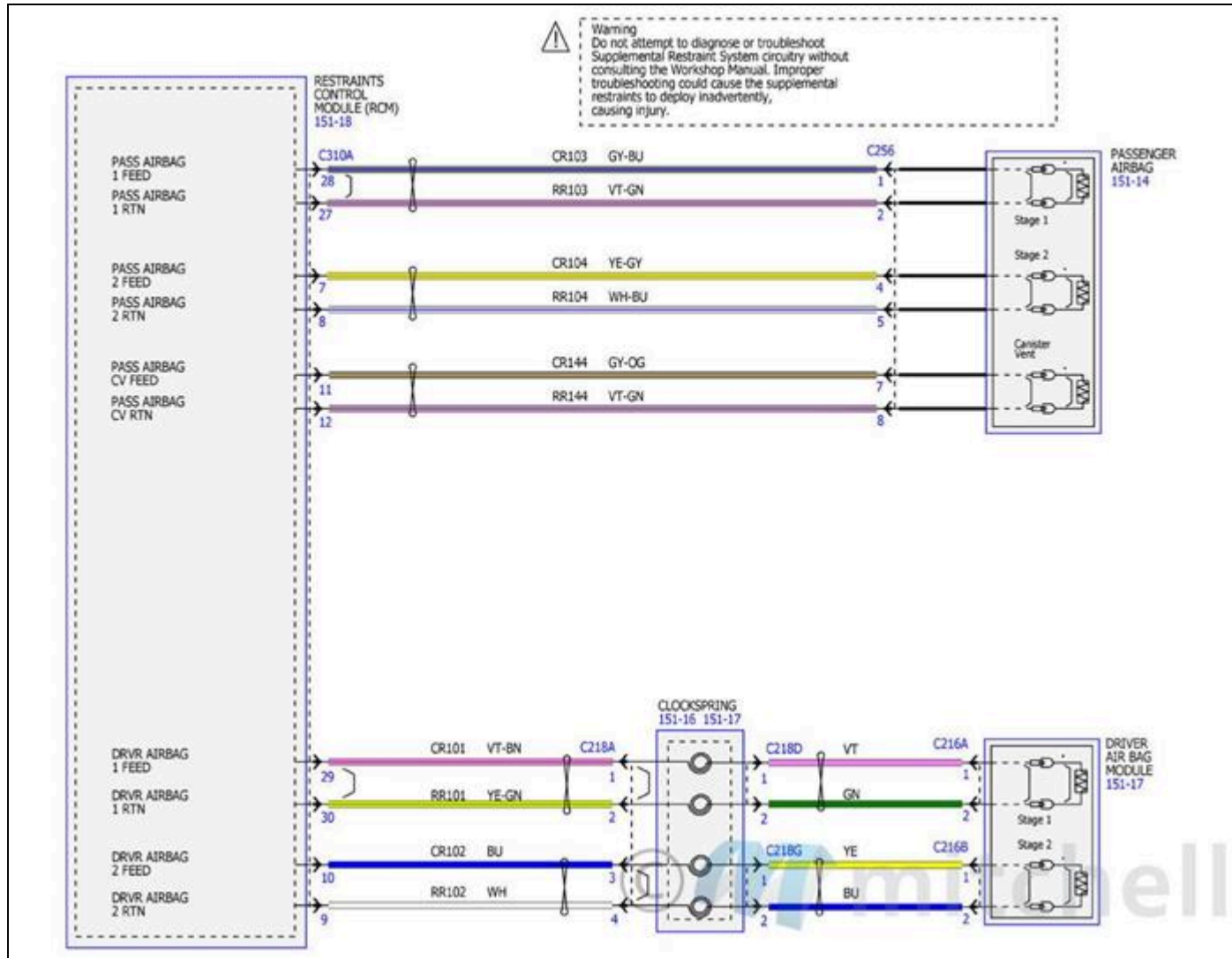
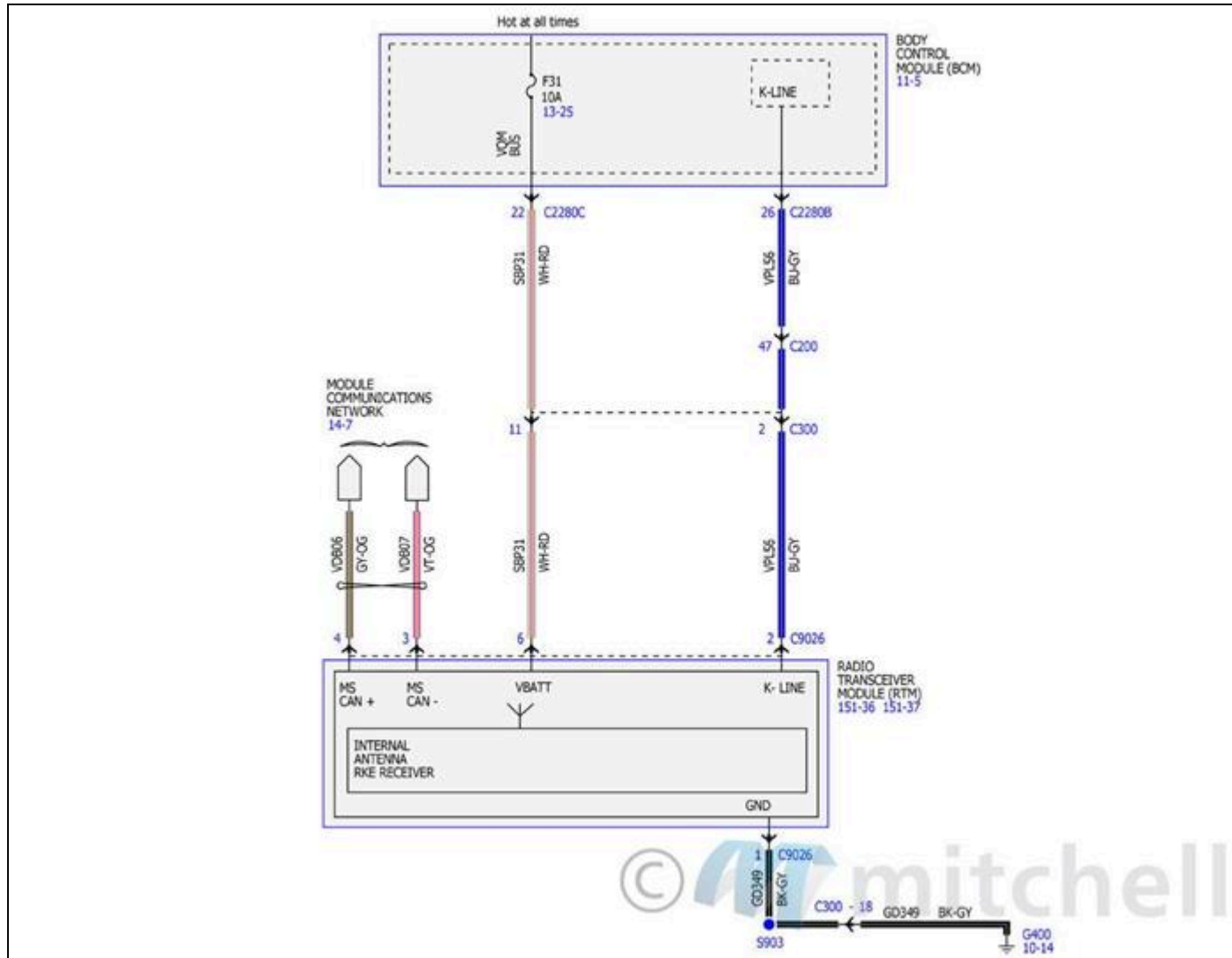

Fig. 196: Diagramas de cableado del sistema de retención suplementario (8 de 8)



SISTEMA DE MONITOREO DE PRESIÓN DE NEUMÁTICOS

Fig. 197: Diagrama de cableado del sistema de control de presión de neumáticos



ADAPTADOR PARA REMOLQUE/CARAVANAS

Fig. 199: Diagramas de cableado del adaptador de remolque/casa rodante (2 de 2)

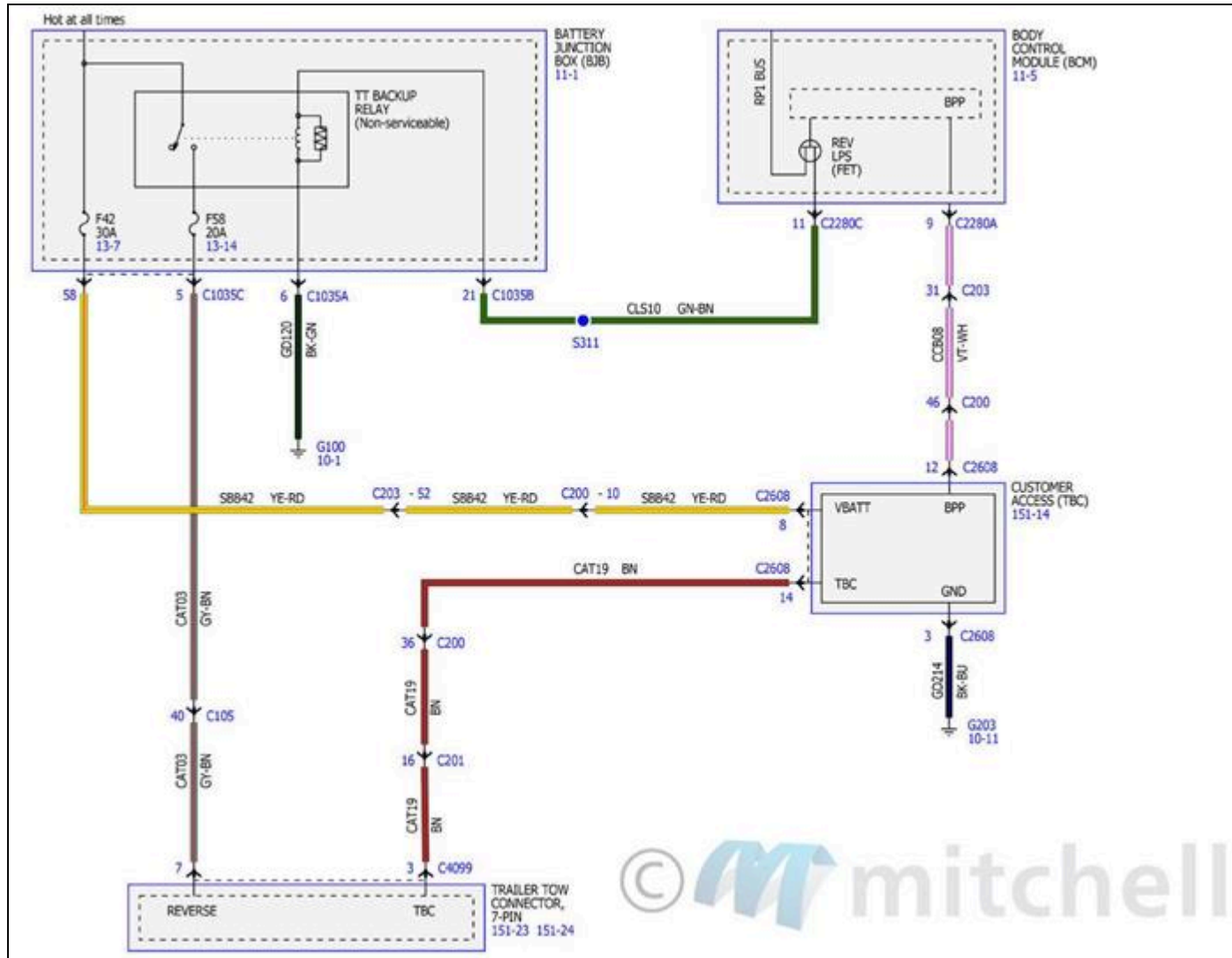

CONTROLES DE TRANSMISIÓN - 10R60

Fig. 200: Diagramas de cableado de los controles de transmisión - 10R60 (1 de 7)

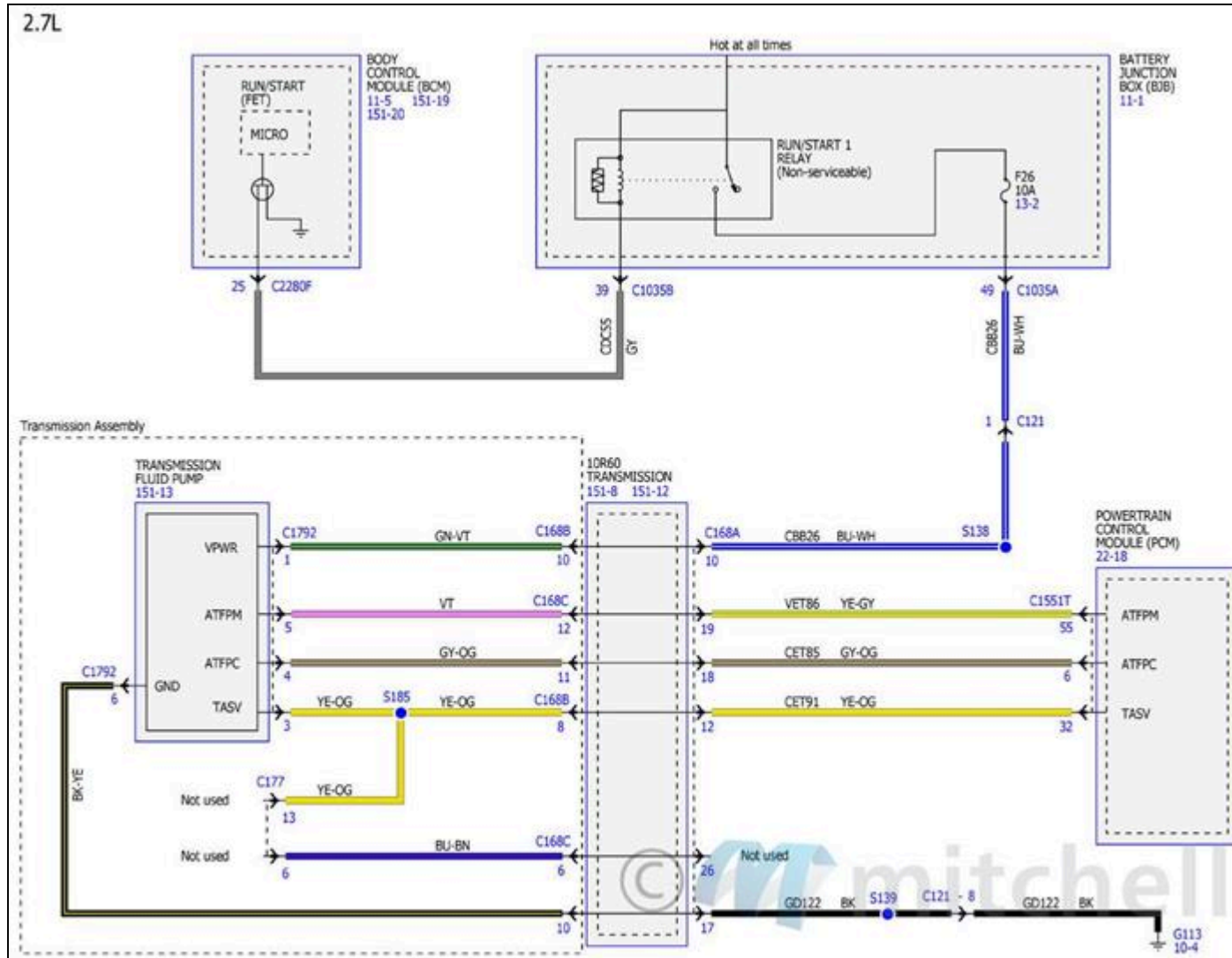

Fig. 201: Diagramas de cableado de los controles de transmisión - 10R60 (2 de 7)

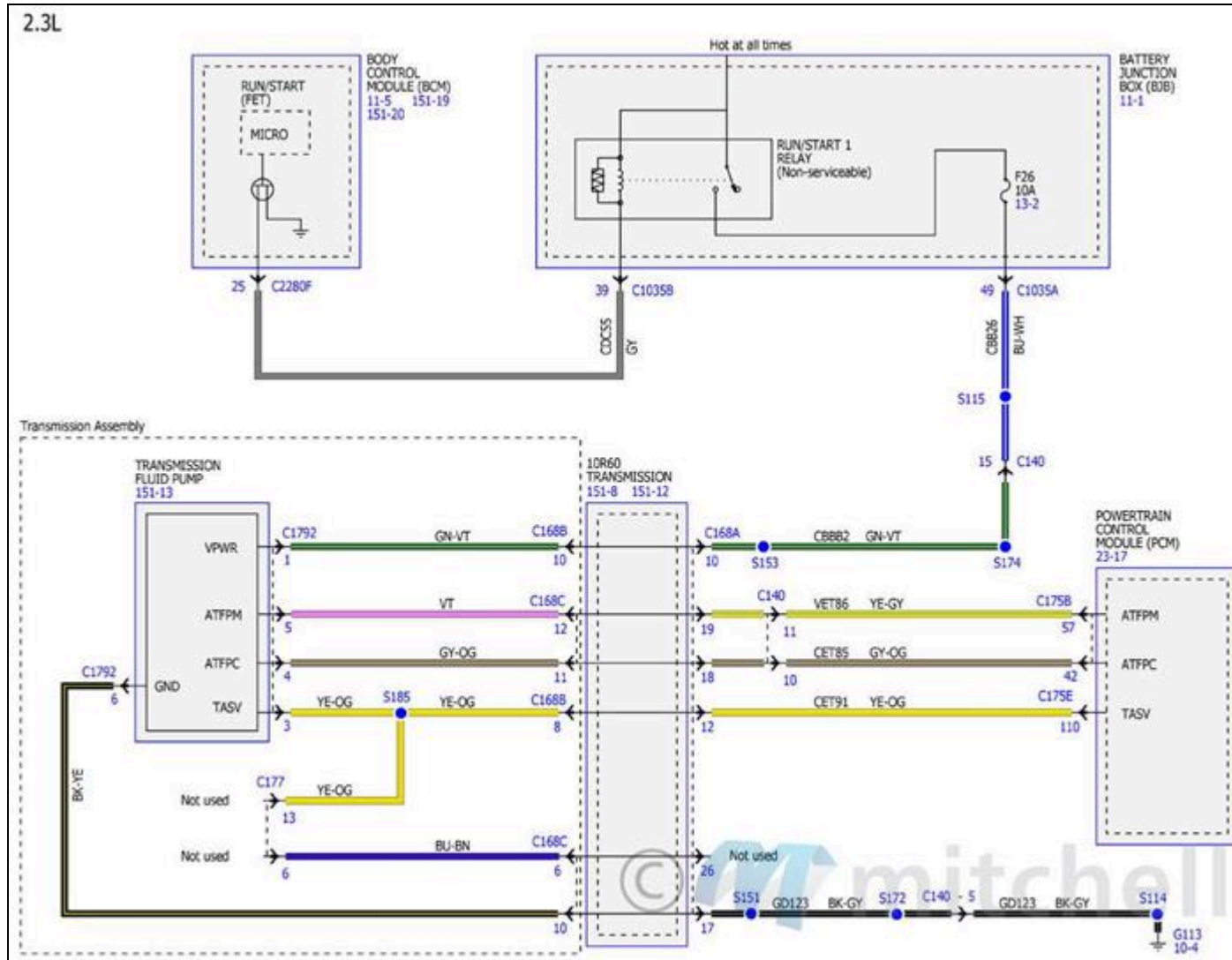

Fig. 202: Diagramas de cableado de los controles de transmisión - 10R60 (3 de 7)

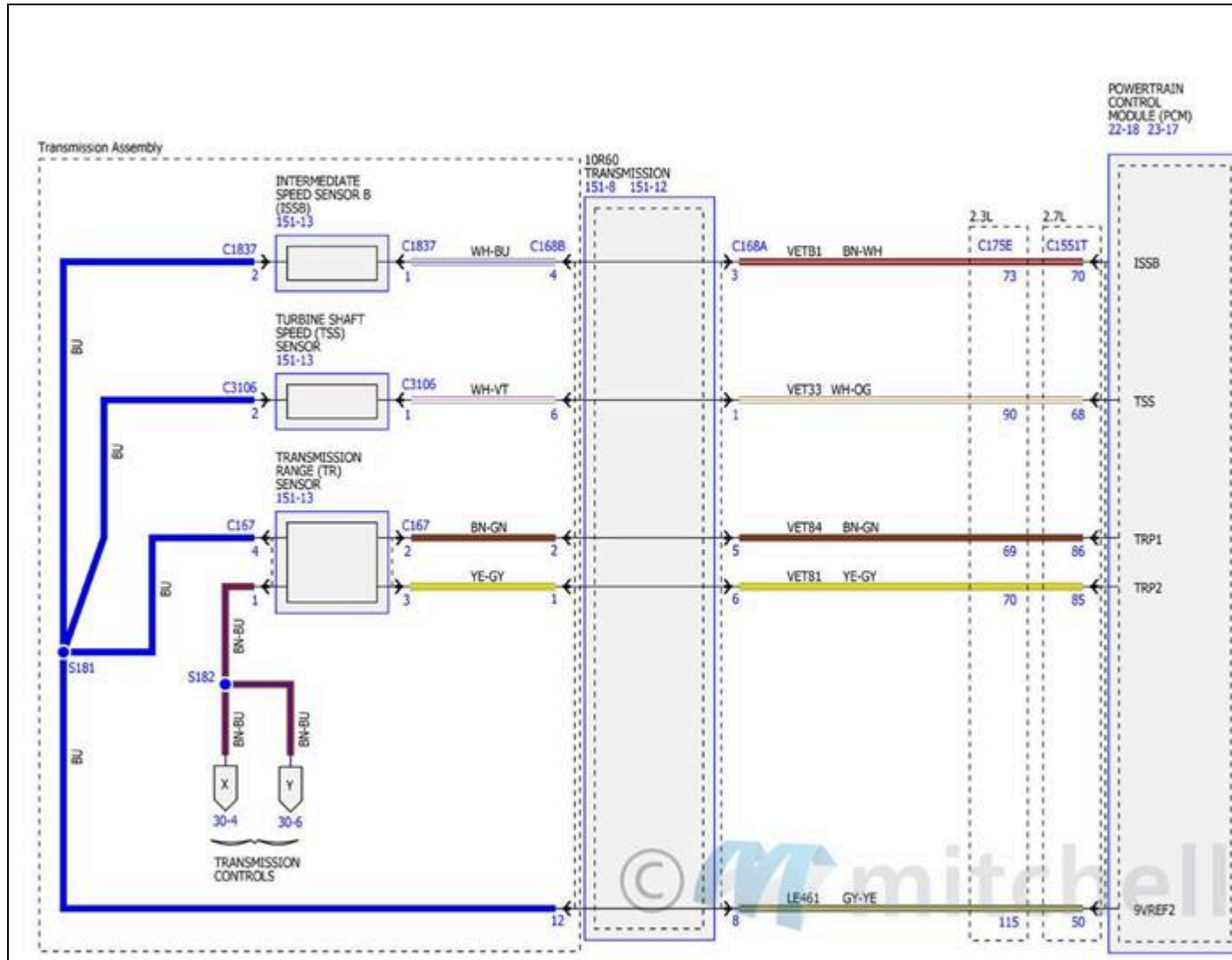

Fig. 203: Diagramas de cableado de los controles de transmisión - 10R60 (4 de 7)

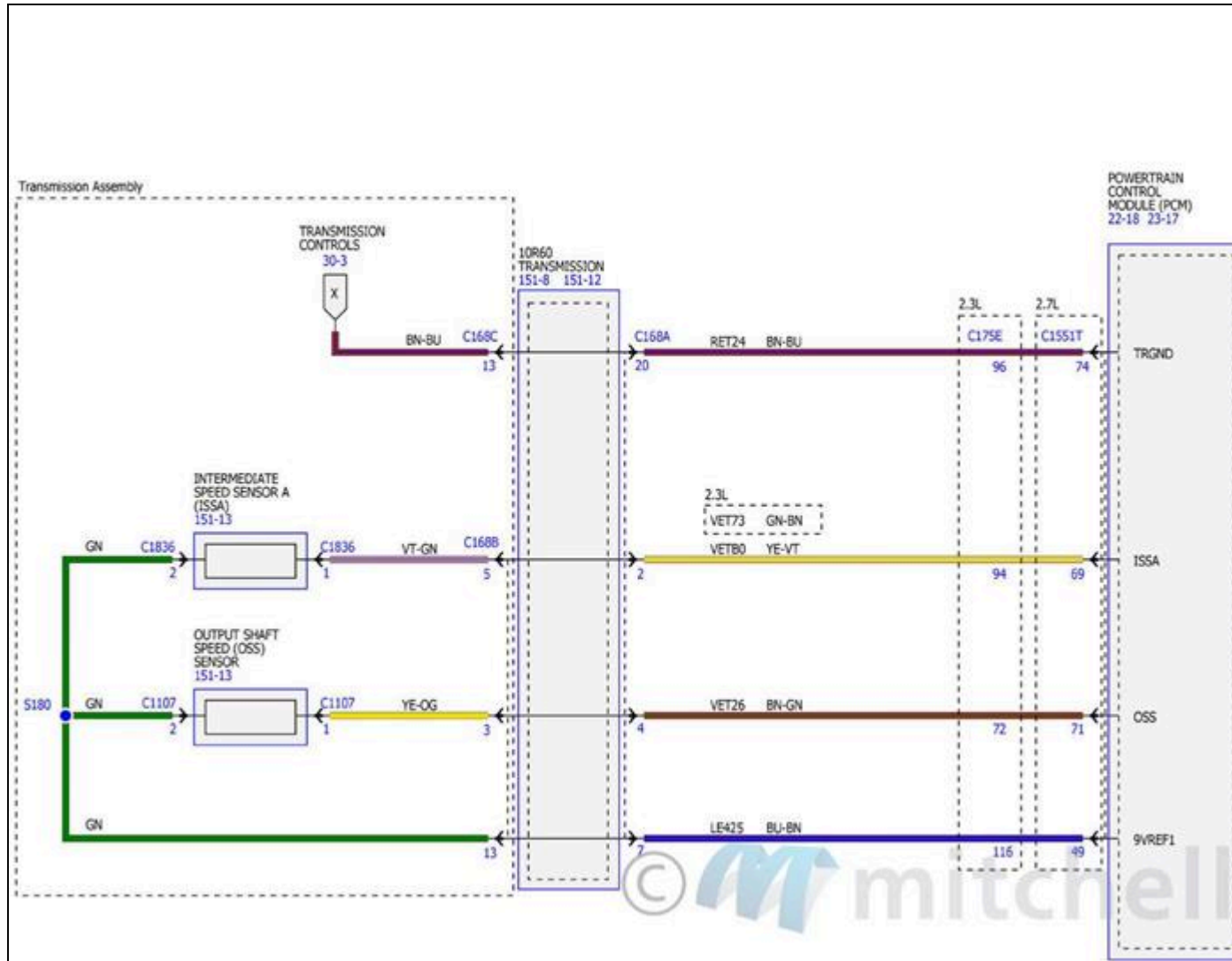

Fig. 204: Diagramas de cableado de los controles de transmisión - 10R60 (5 de 7)

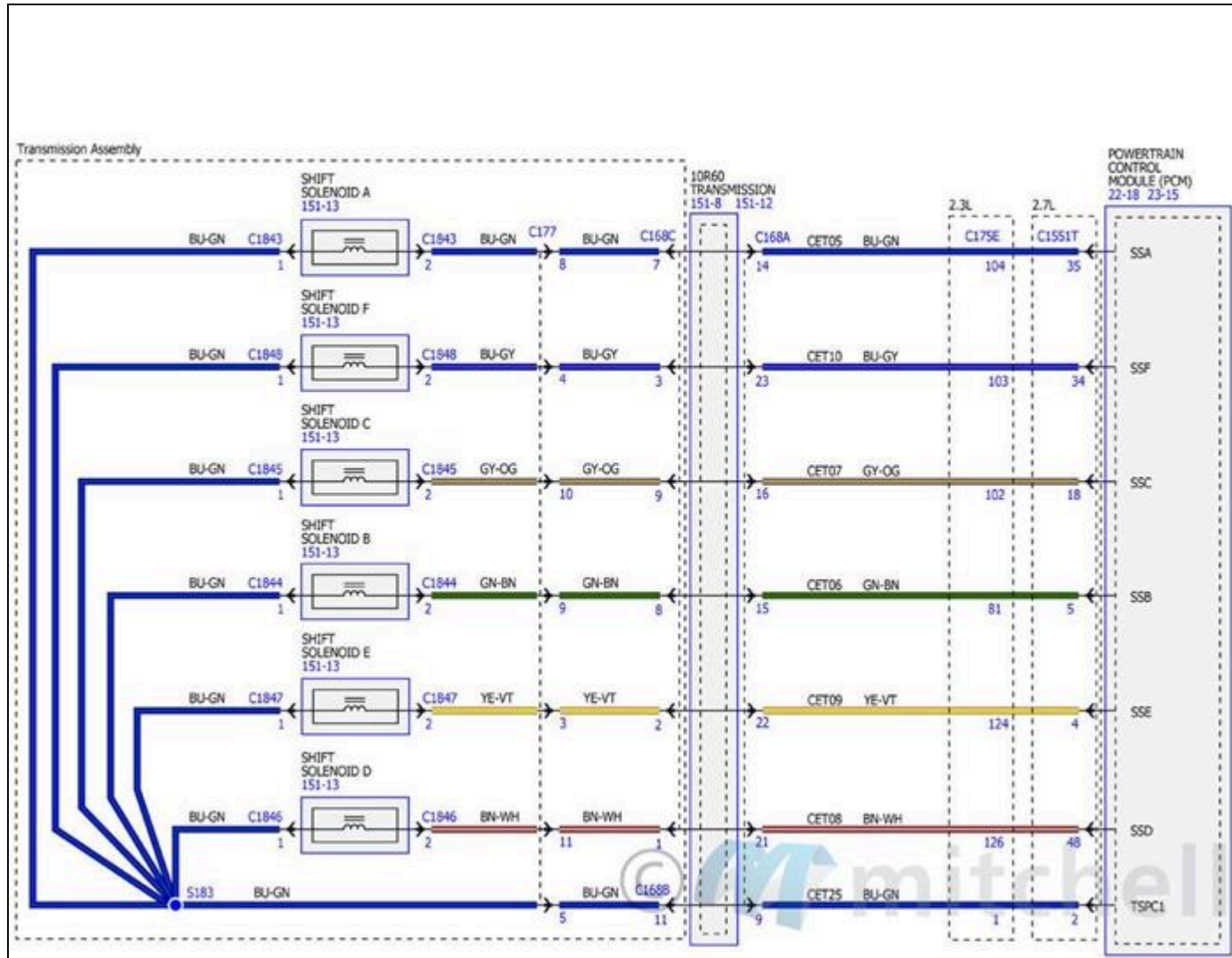

Fig. 205: Diagramas de cableado de los controles de transmisión - 10R60 (6 de 7)

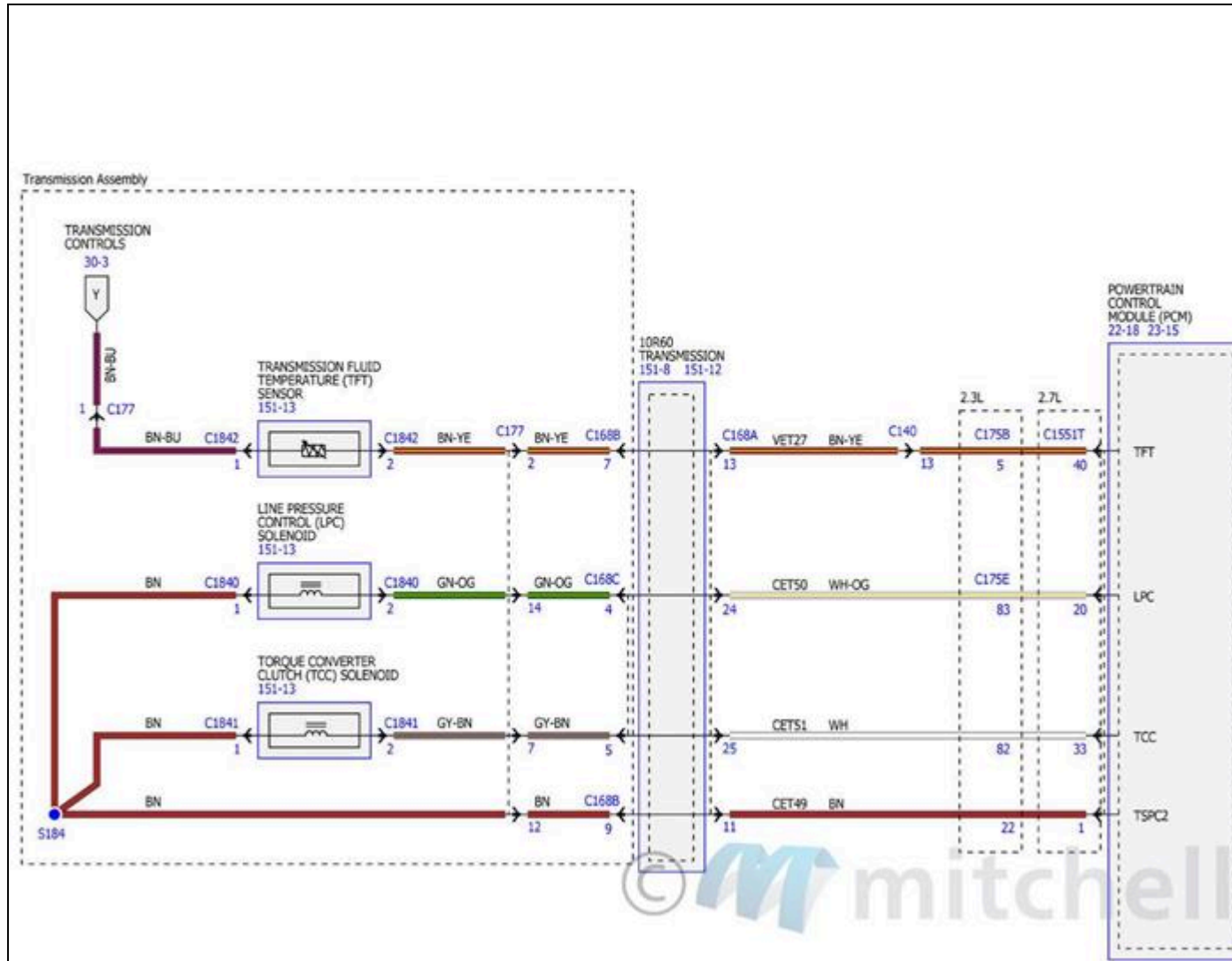
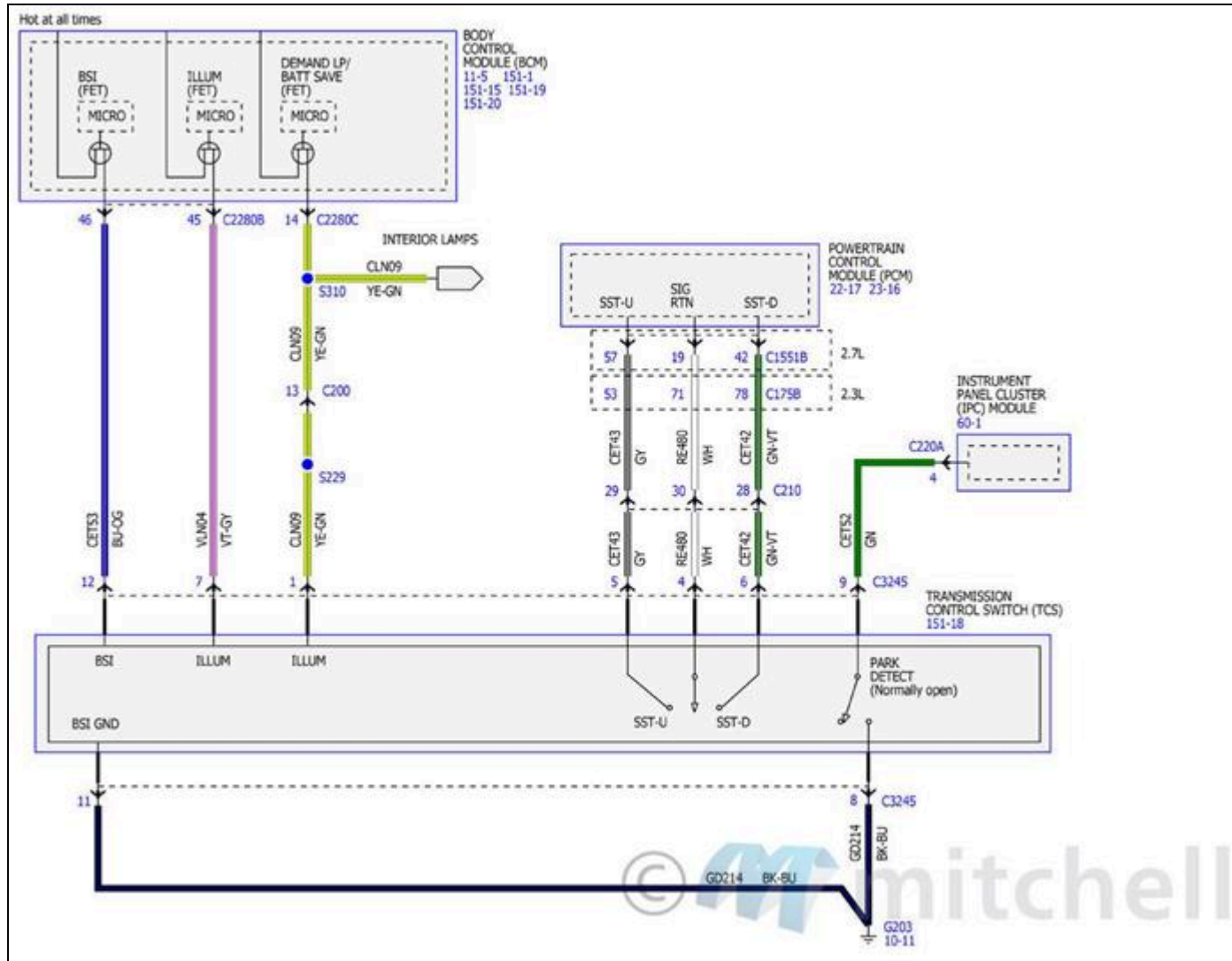

Fig. 206: Diagramas de cableado de los controles de transmisión - 10R60 (7 de 7)



LUCES DE SEÑAL DE GIRO/PARADA/PELIGRO

Fig. 207: Diagramas de cableado de luces de señal de giro, de freno y de emergencia (1 de 6)

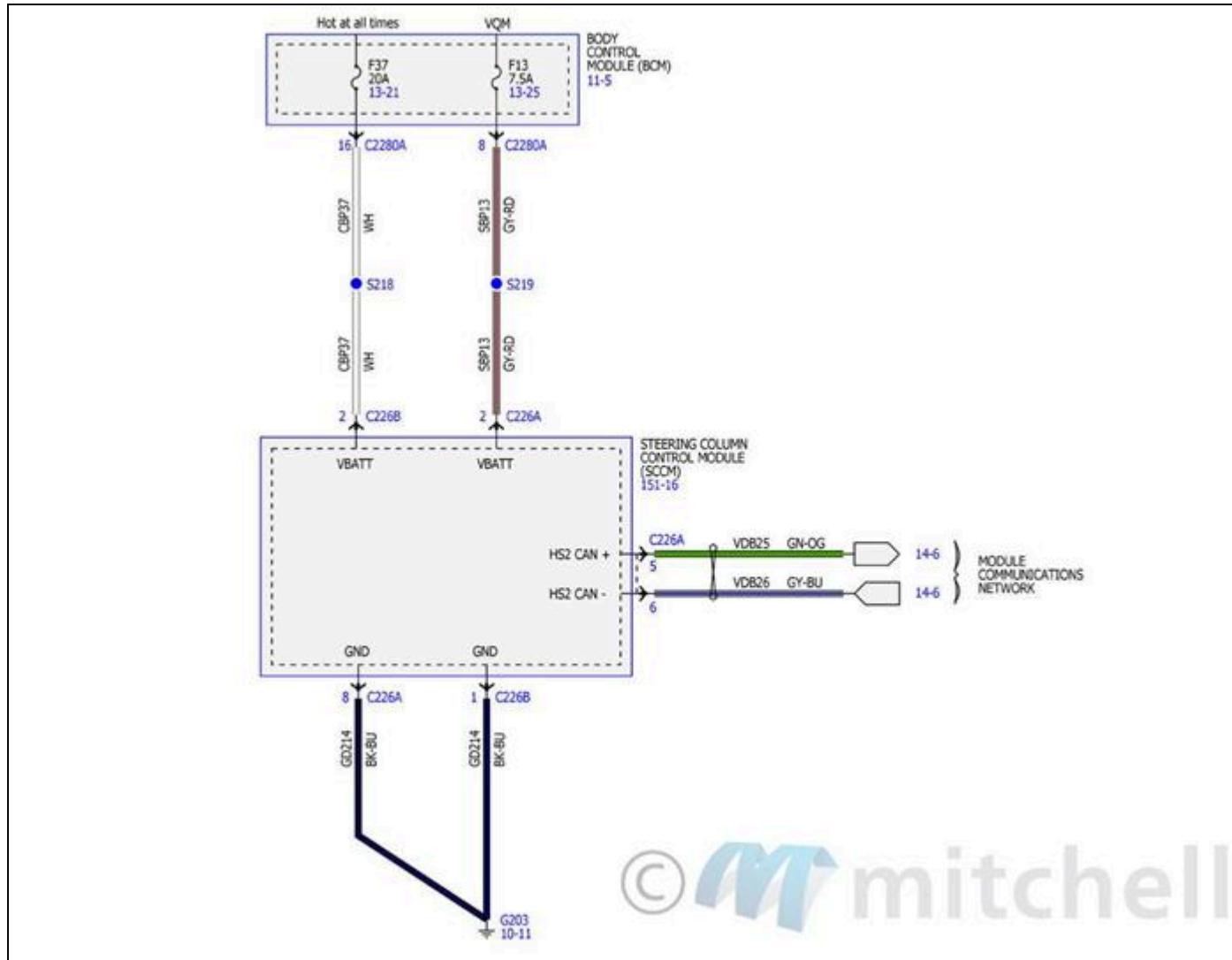

Fig. 208: Diagramas de cableado de luces de señal de giro, de freno y de emergencia (2 de 6)

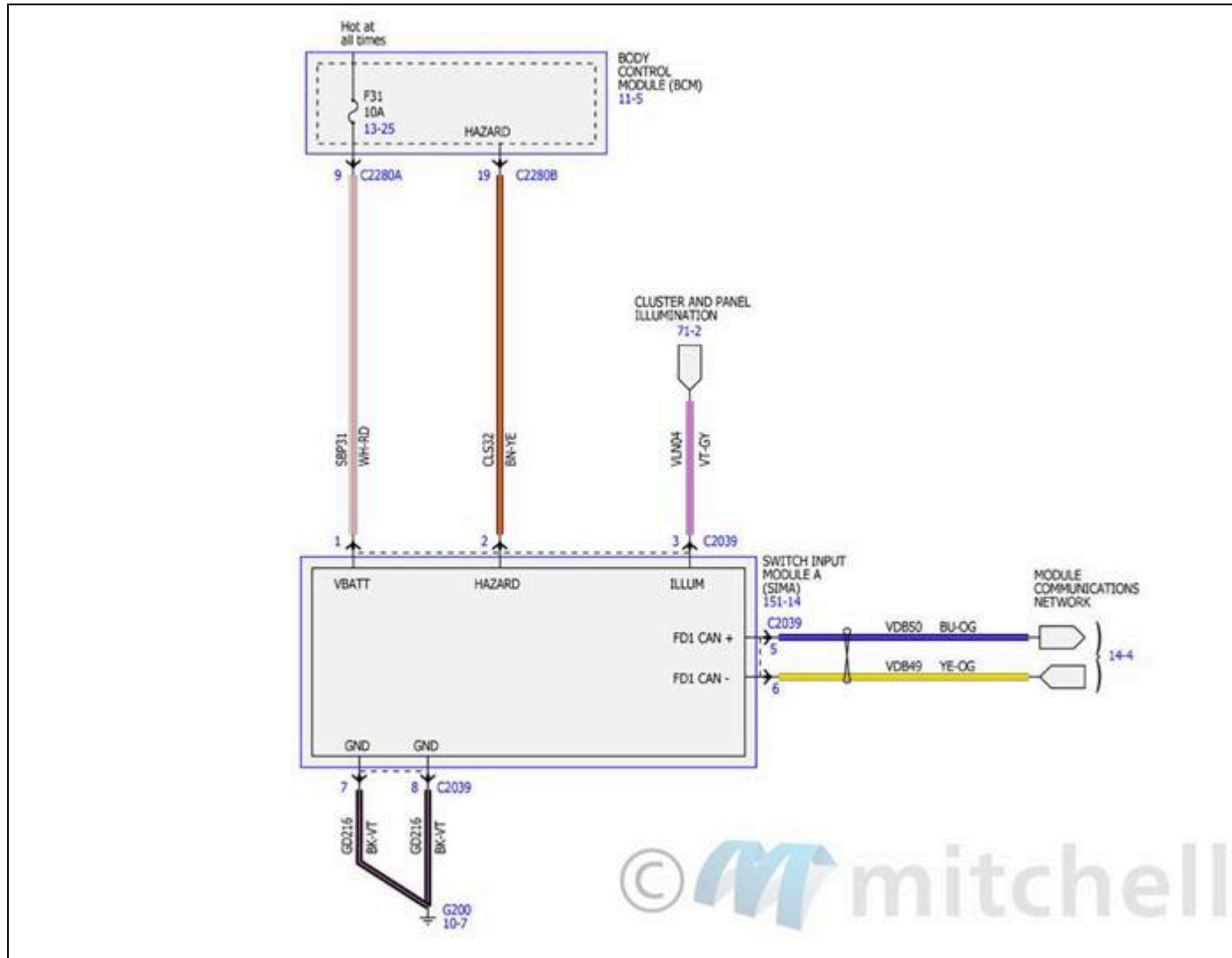

Fig. 209: Diagramas de cableado de luces de señal de giro, de freno y de emergencia (3 de 6)

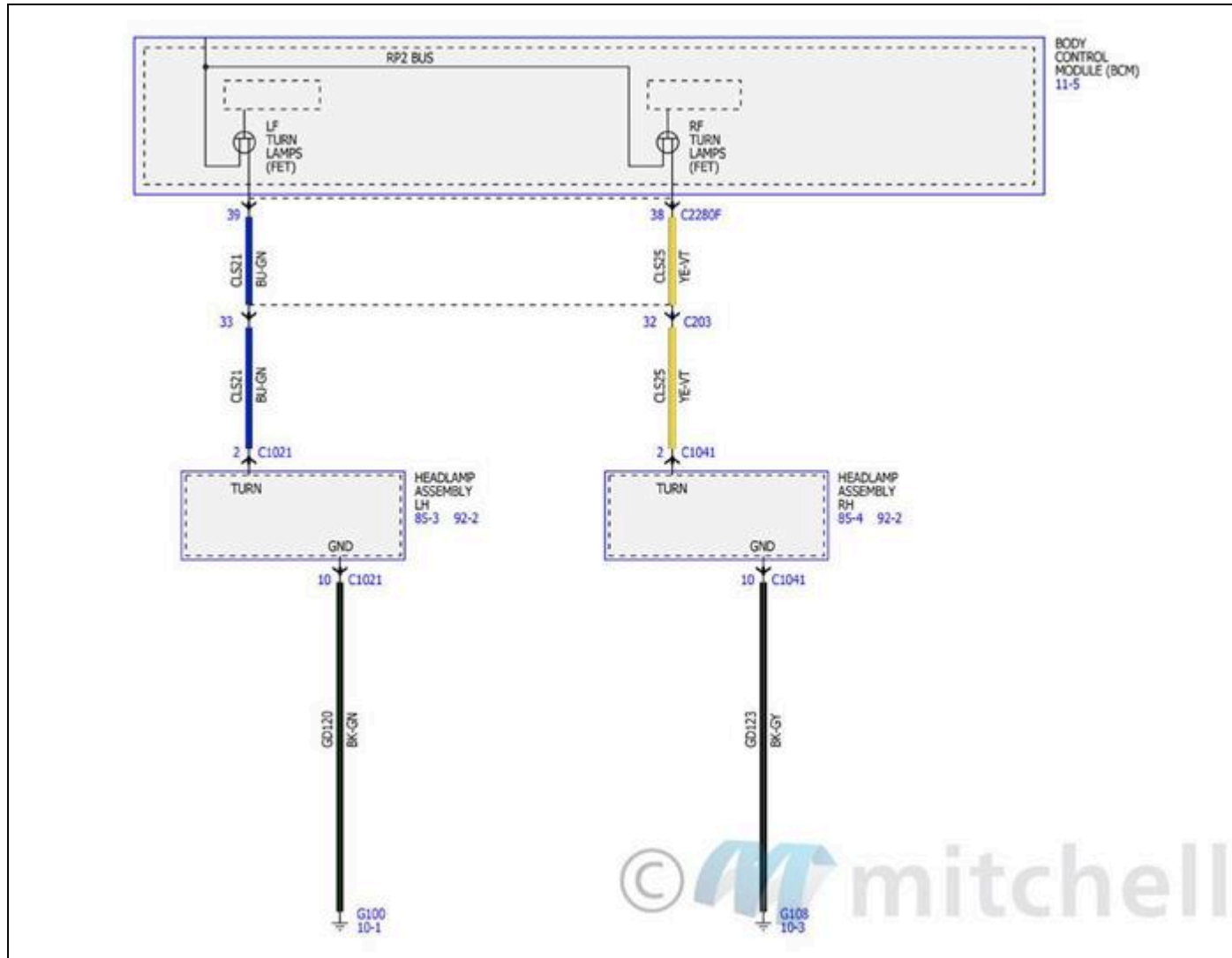

Fig. 210: Diagramas de cableado de luces de giro, de freno y de emergencia (4 de 6)

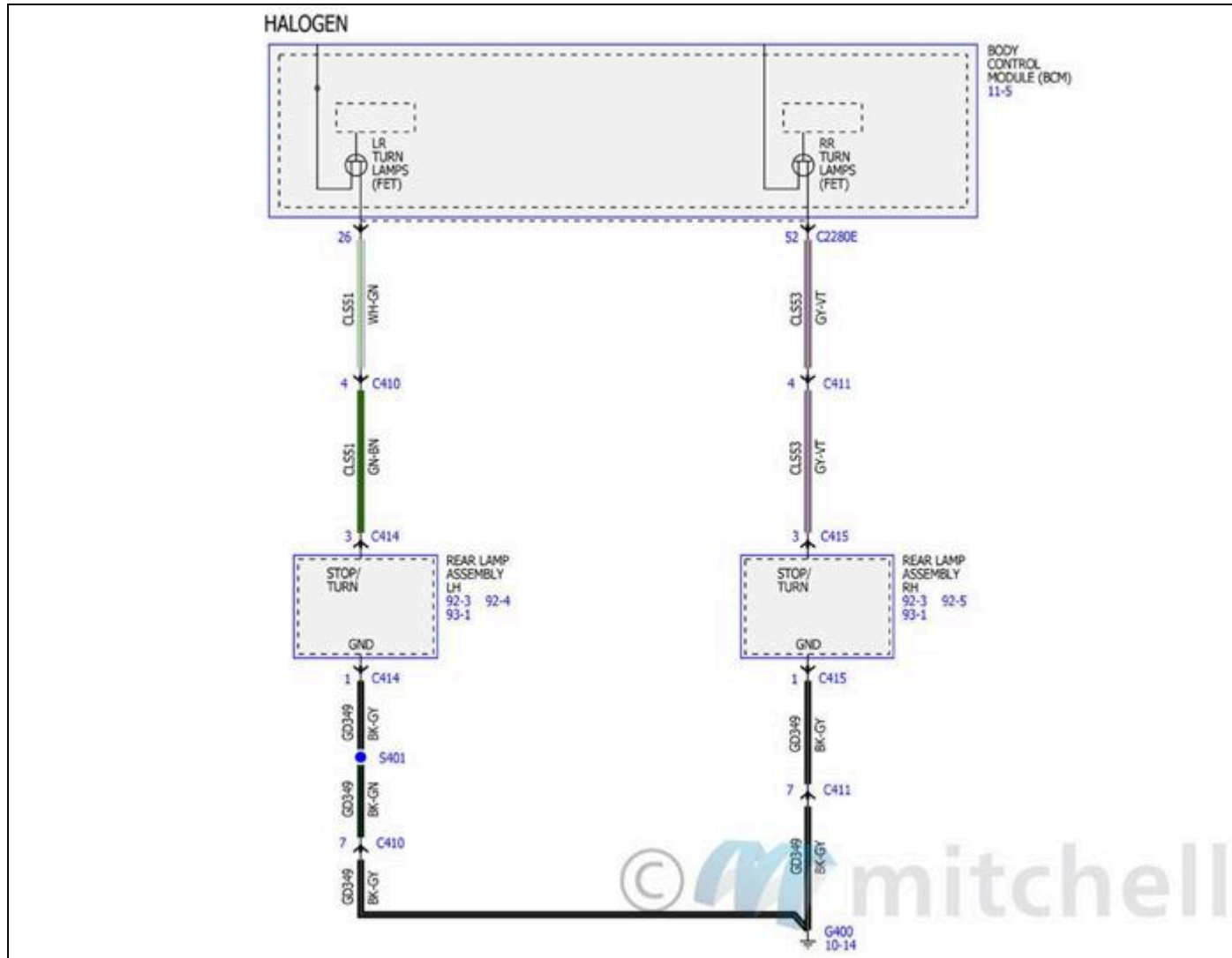

Fig. 211: Diagramas de cableado de luces de señal de giro, de freno y de emergencia (5 de 6)

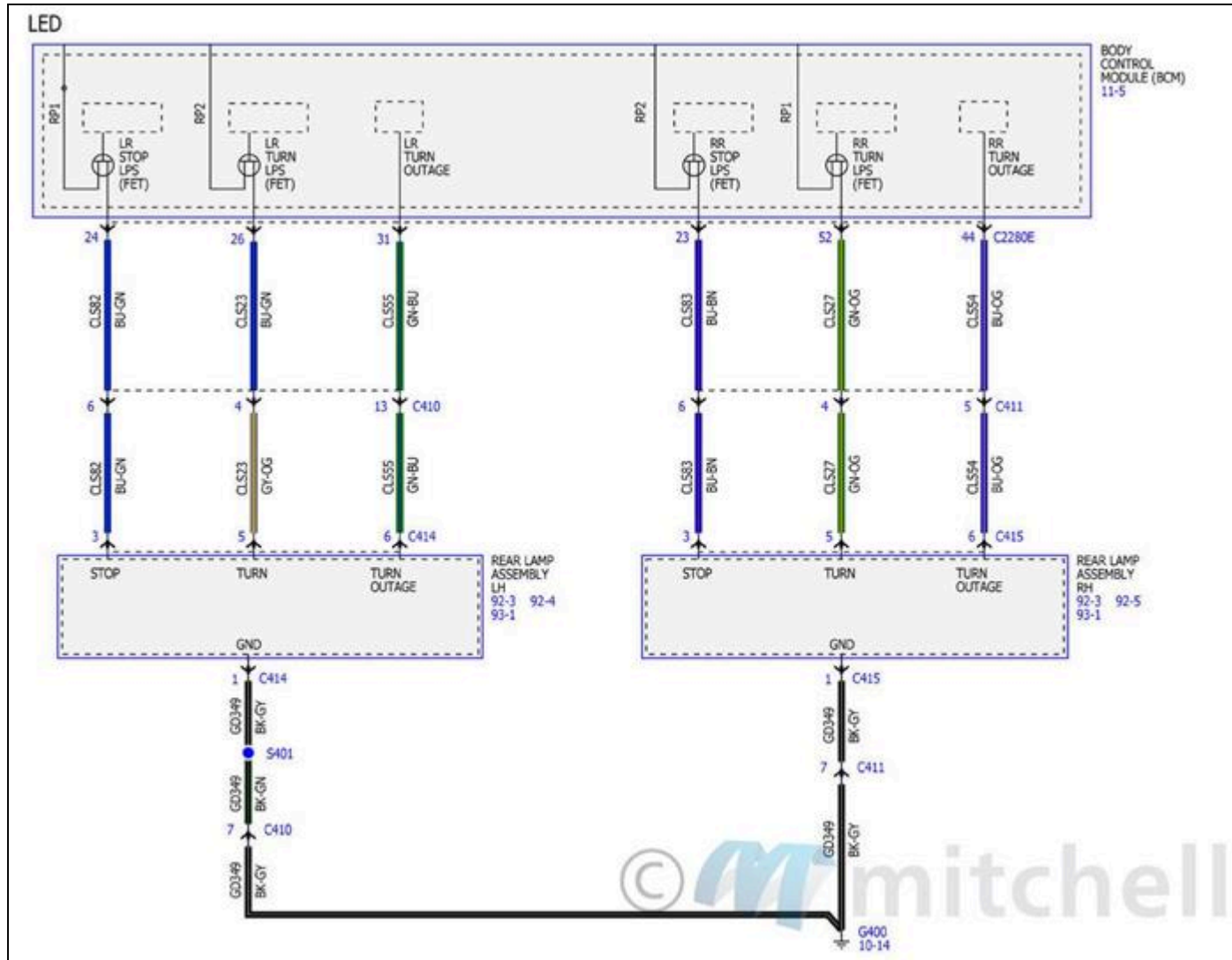
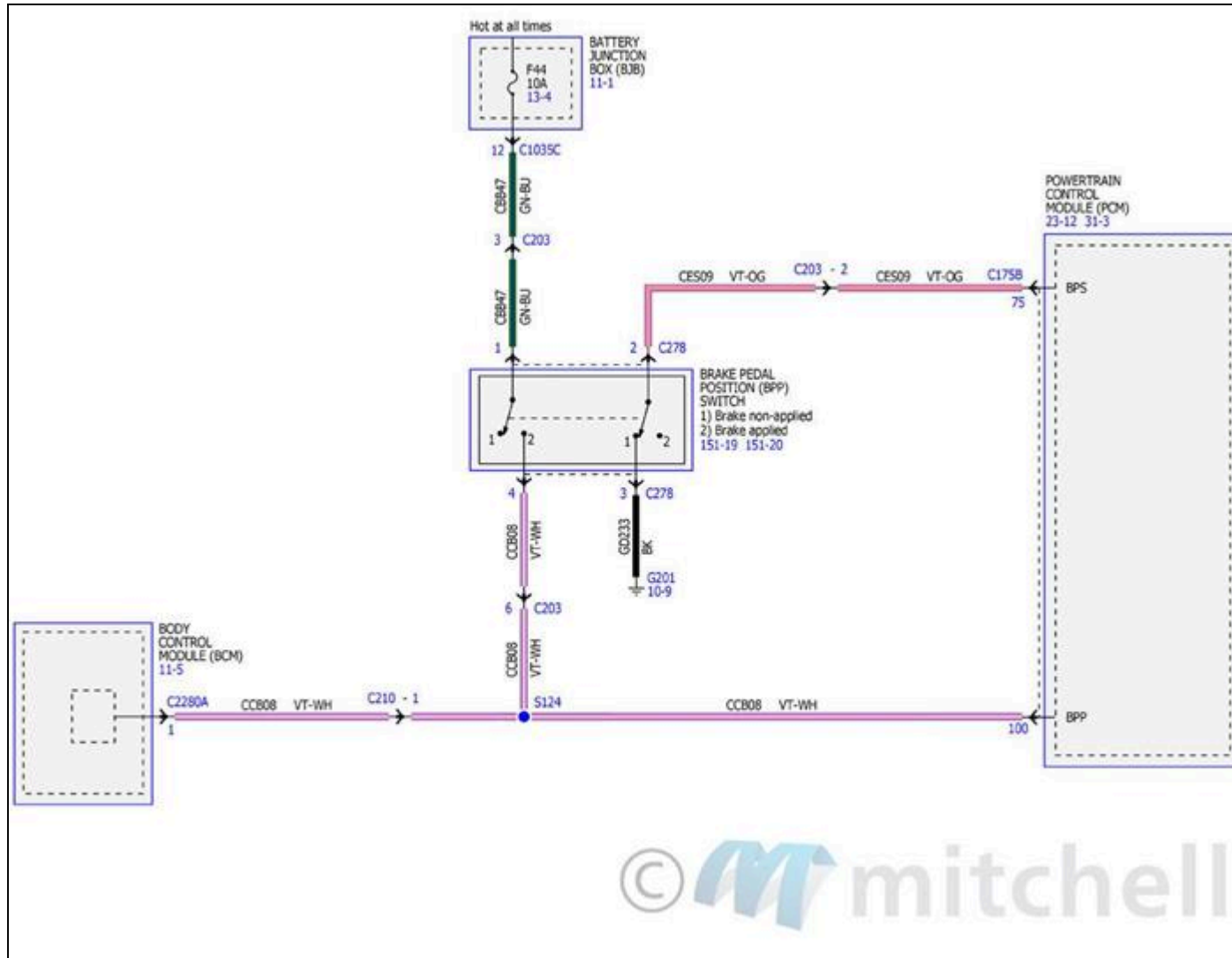

Fig. 212: Diagramas de cableado de luces de señal de giro, de freno y de emergencia (6 de 6)



SUSPENSIÓN DINÁMICA DEL VEHÍCULO

Fig. 213: Diagramas de cableado de la suspensión dinámica del vehículo (1 de 2)

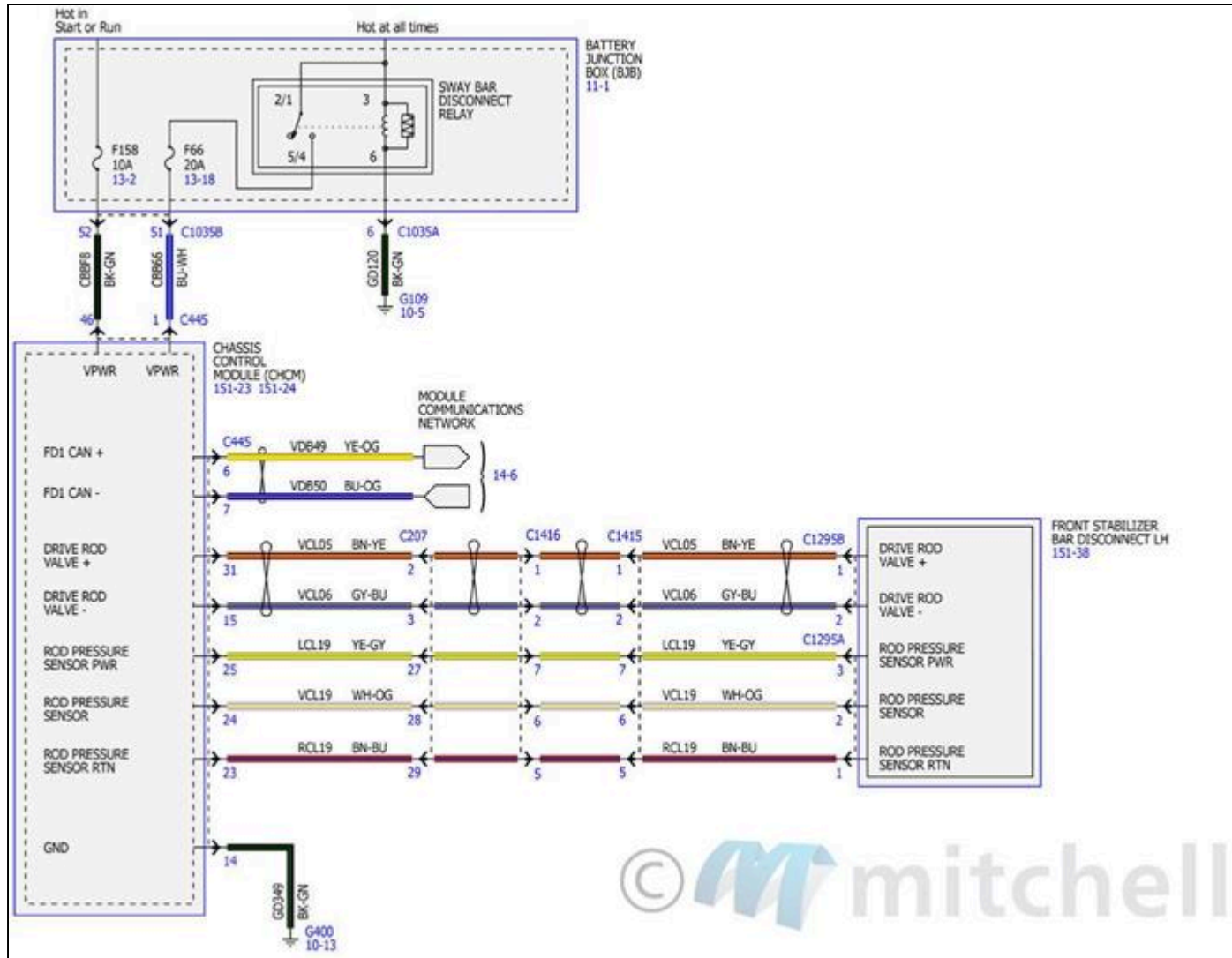
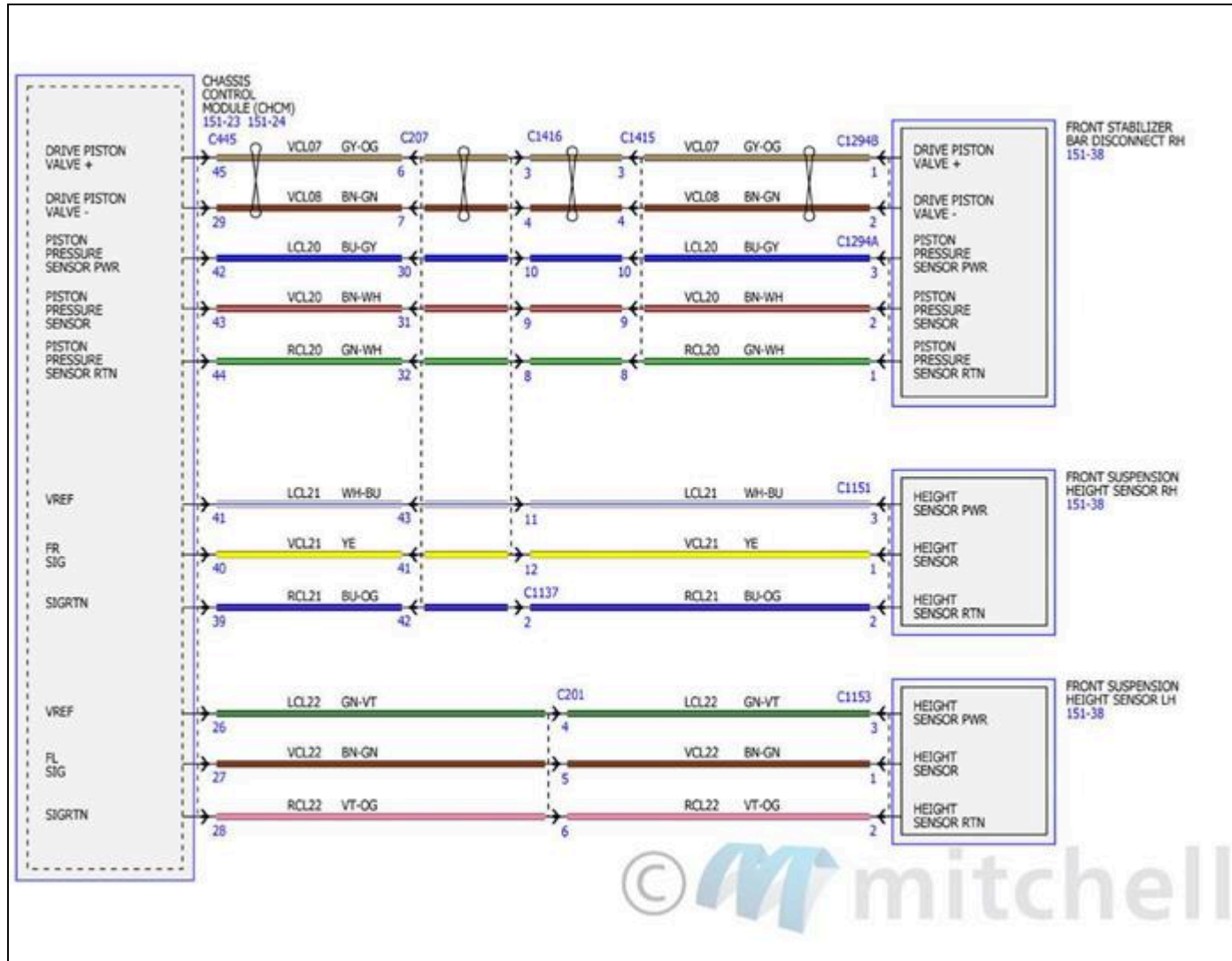

Fig. 214: Diagramas de cableado de la suspensión dinámica del vehículo (2 de 2)



SISTEMAS DINÁMICOS DEL VEHÍCULO

Fig. 215: Diagramas de cableado de los sistemas dinámicos del vehículo (1 de 3)

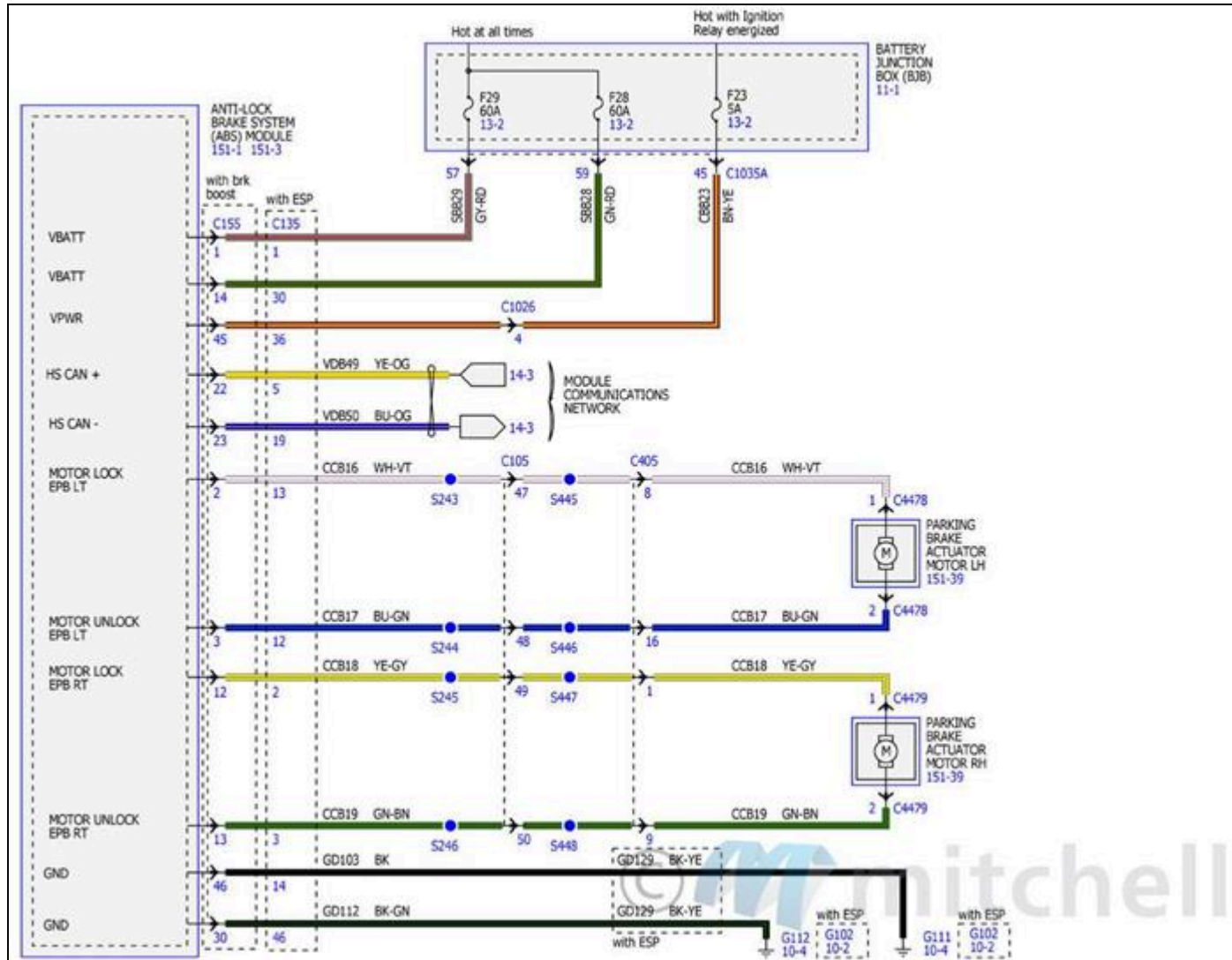

Fig. 216: Diagramas de cableado de los sistemas dinámicos del vehículo (2 de 3)

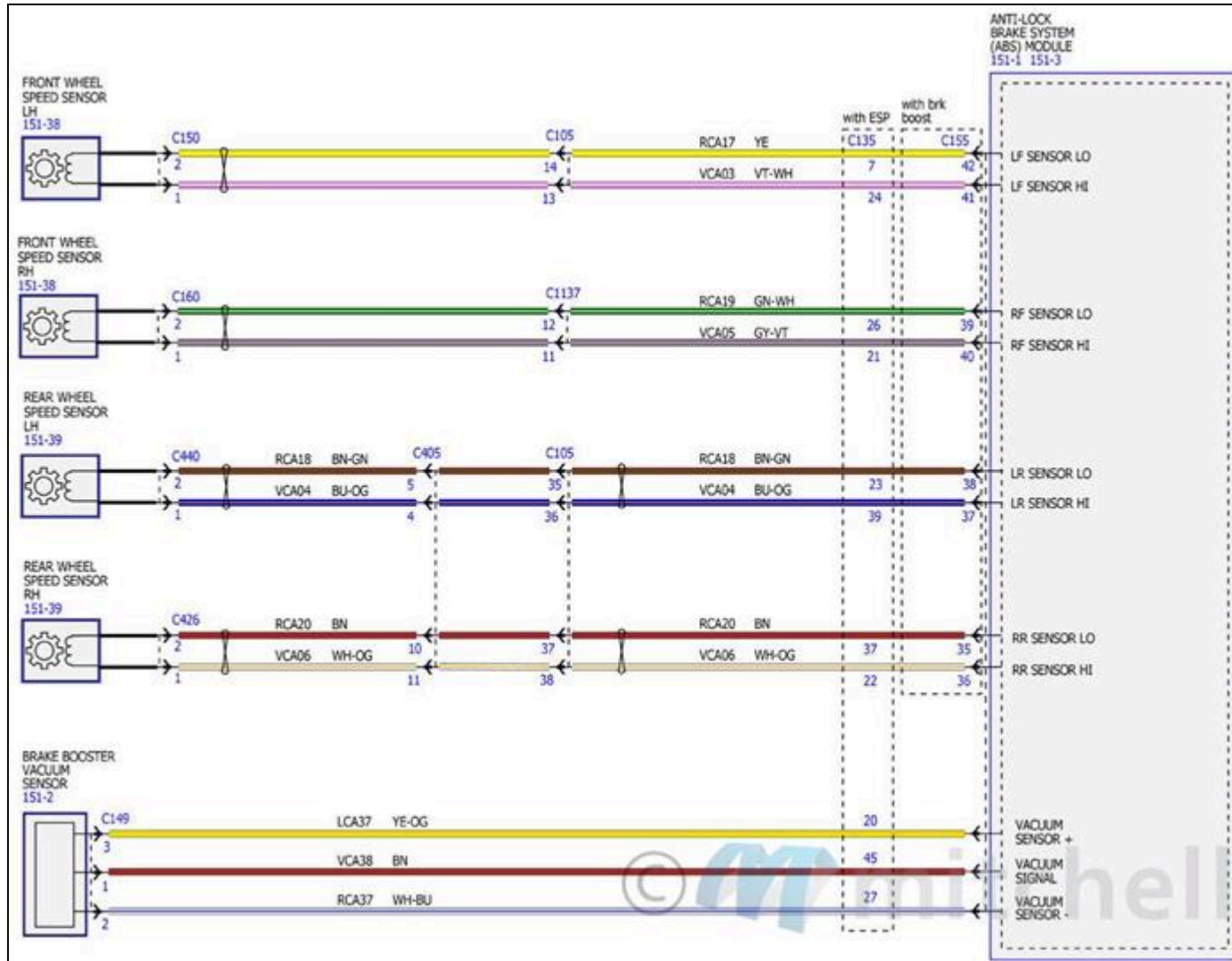
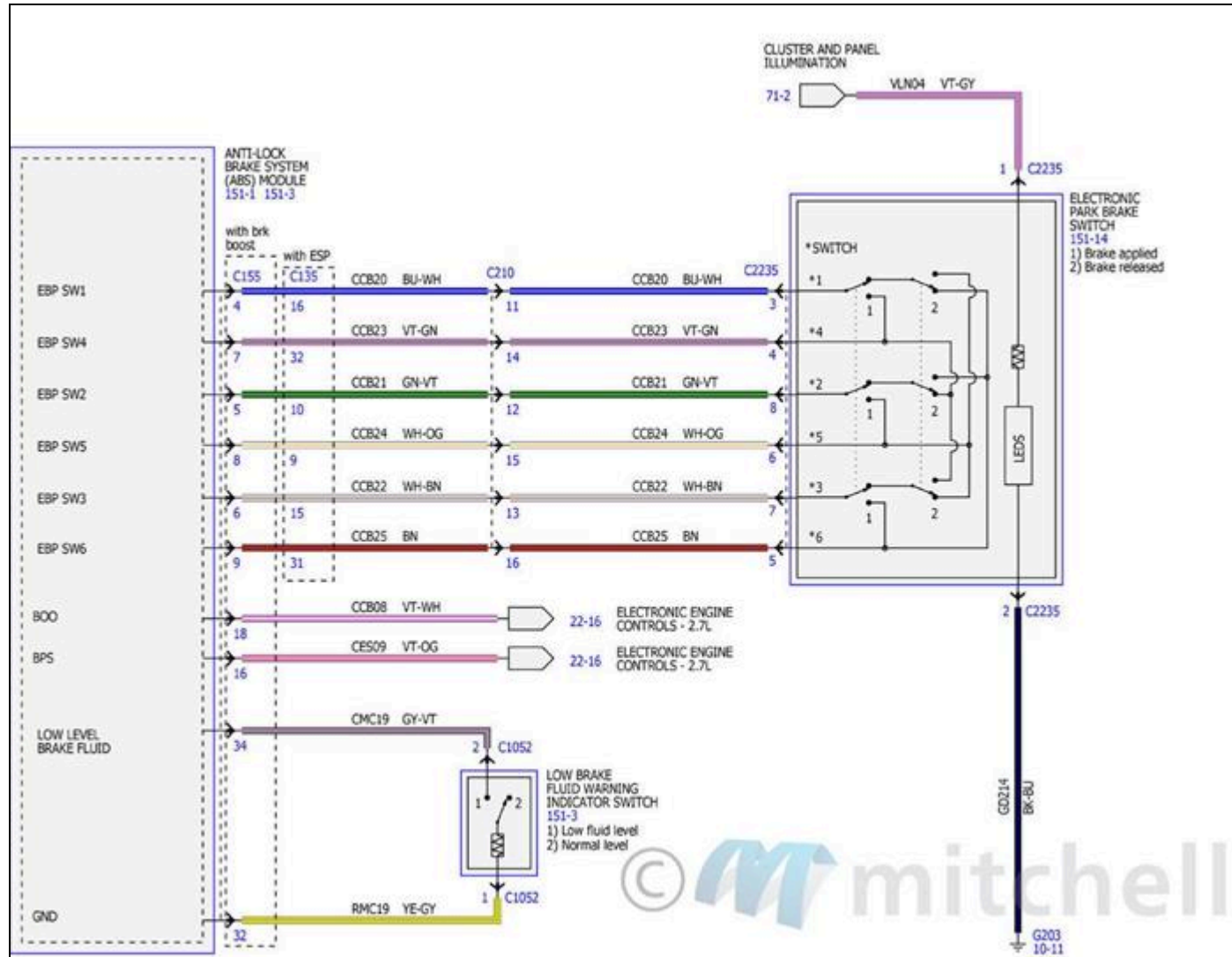

Fig. 217: Diagramas de cableado de sistemas dinámicos del vehículo (3 de 3)



SISTEMA DE MENSAJERÍA DE EMERGENCIA PARA VEHÍCULOS

Fig. 218: Diagramas de cableado del sistema de mensajería de emergencia del vehículo (1 de 8)

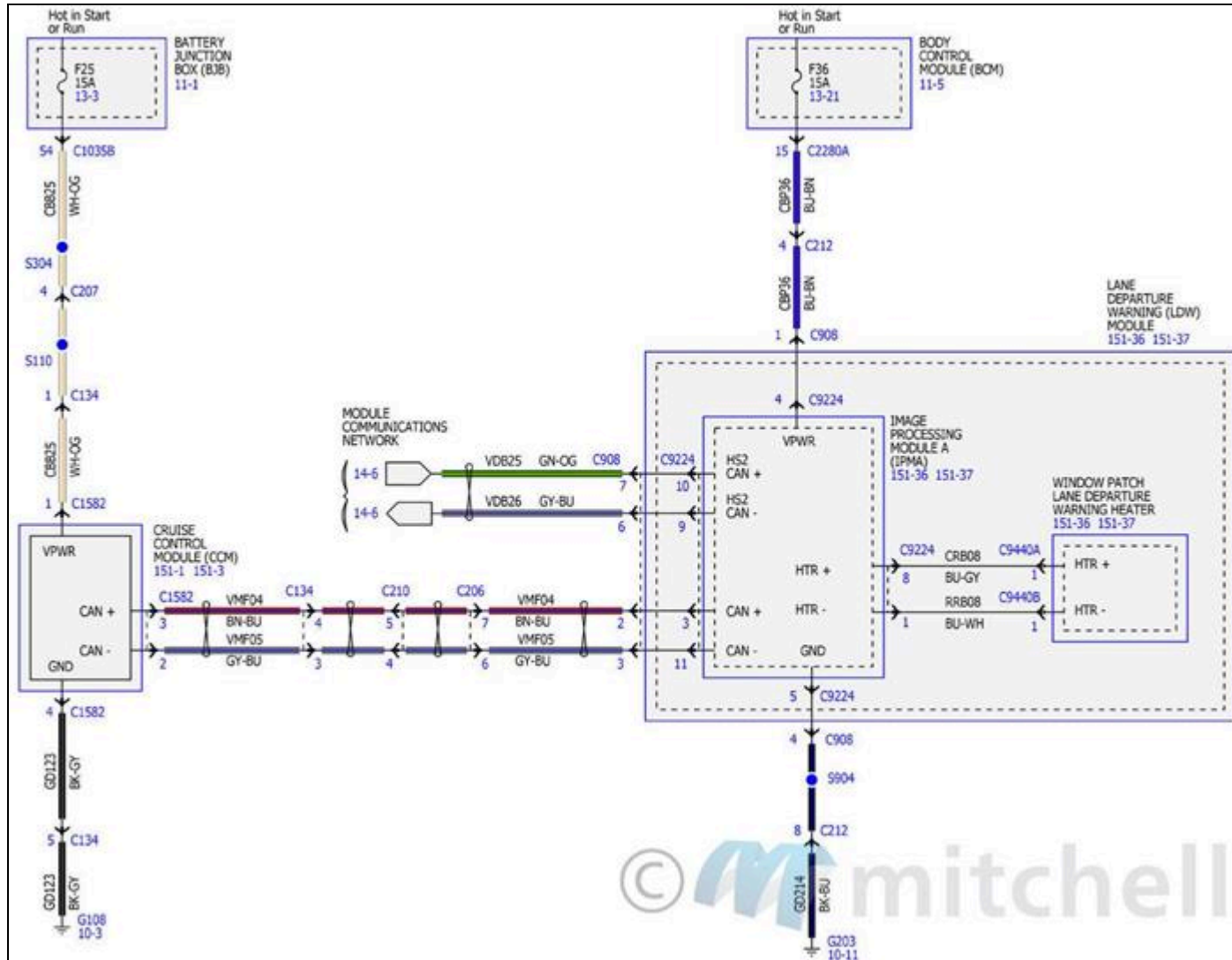

Fig. 219: Diagramas de cableado del sistema de mensajería de emergencia del vehículo (2 de 8)

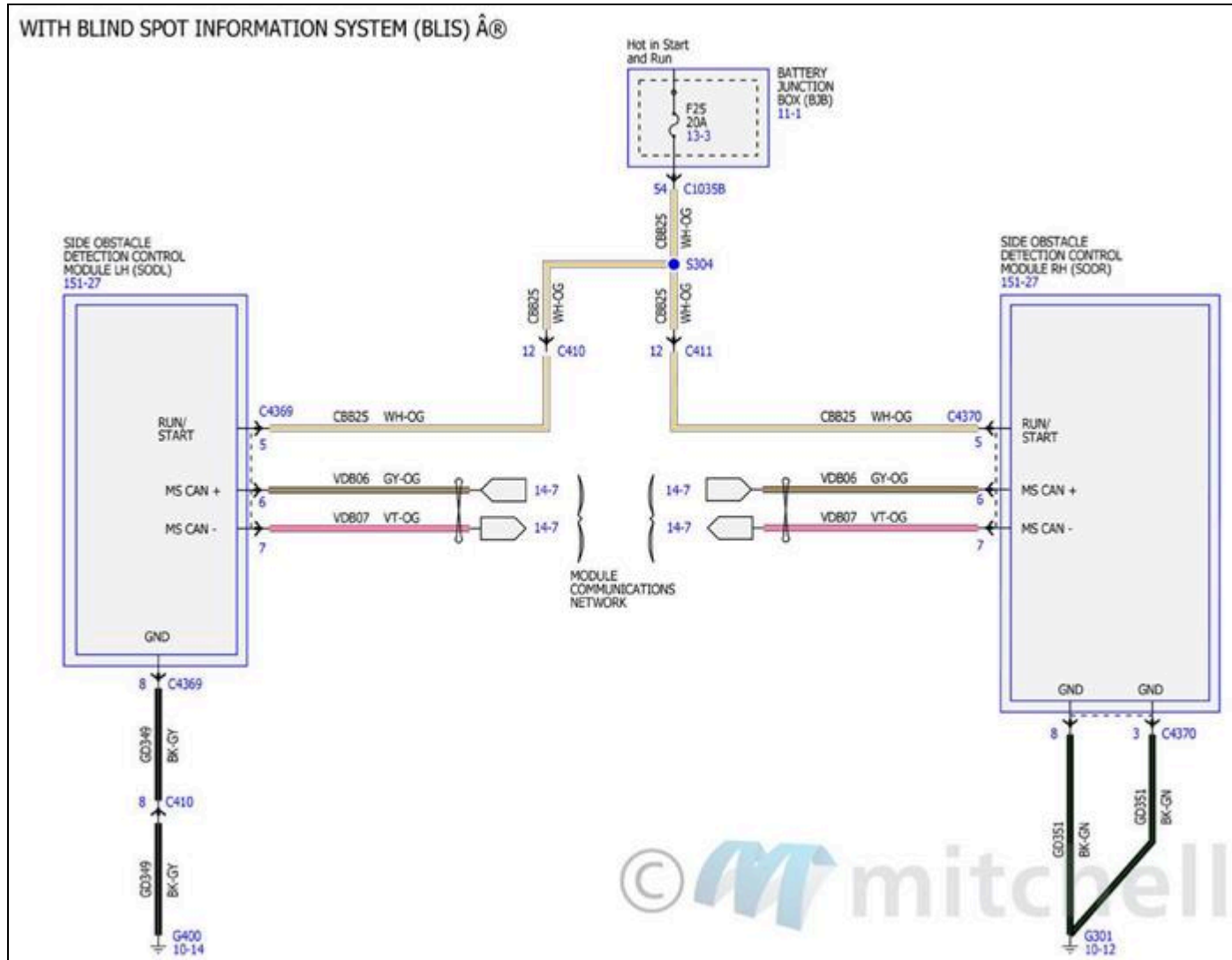

Fig. 220: Diagramas de cableado del sistema de mensajería de emergencia del vehículo (3 de 8)

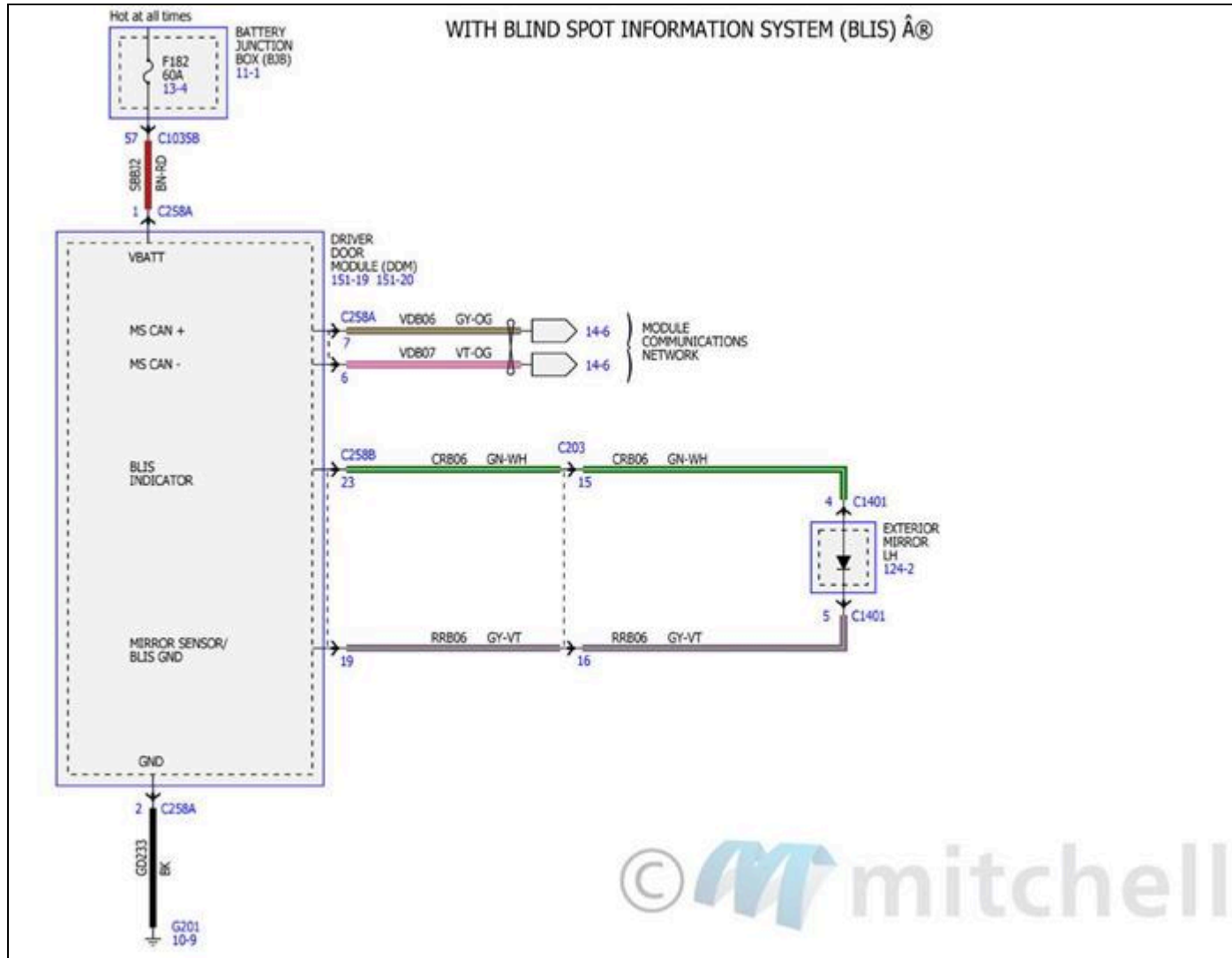

Fig. 221: Diagramas de cableado del sistema de mensajería de emergencia del vehículo (4 de 8)

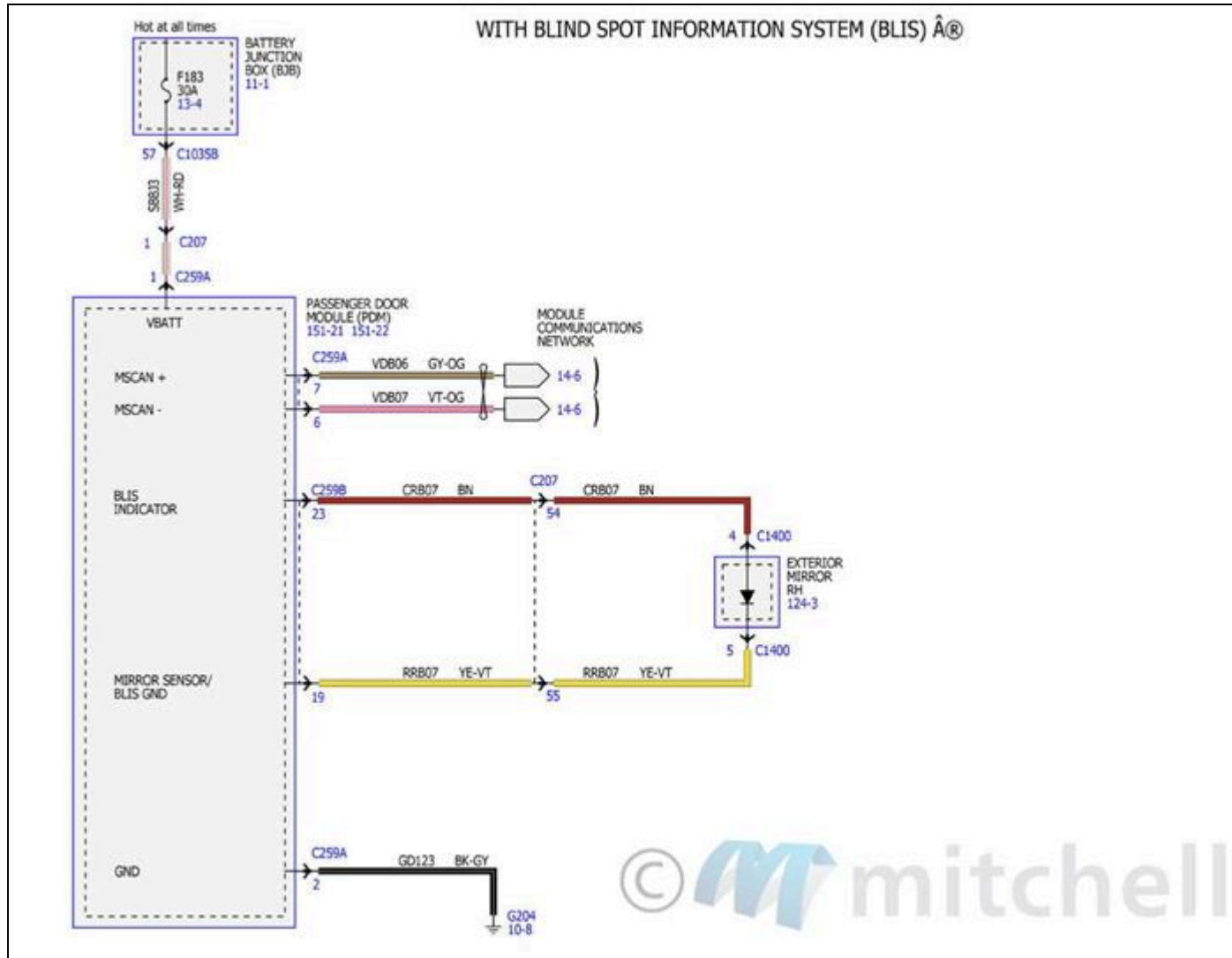

Fig. 222: Diagramas de cableado del sistema de mensajería de emergencia del vehículo (5 de 8)

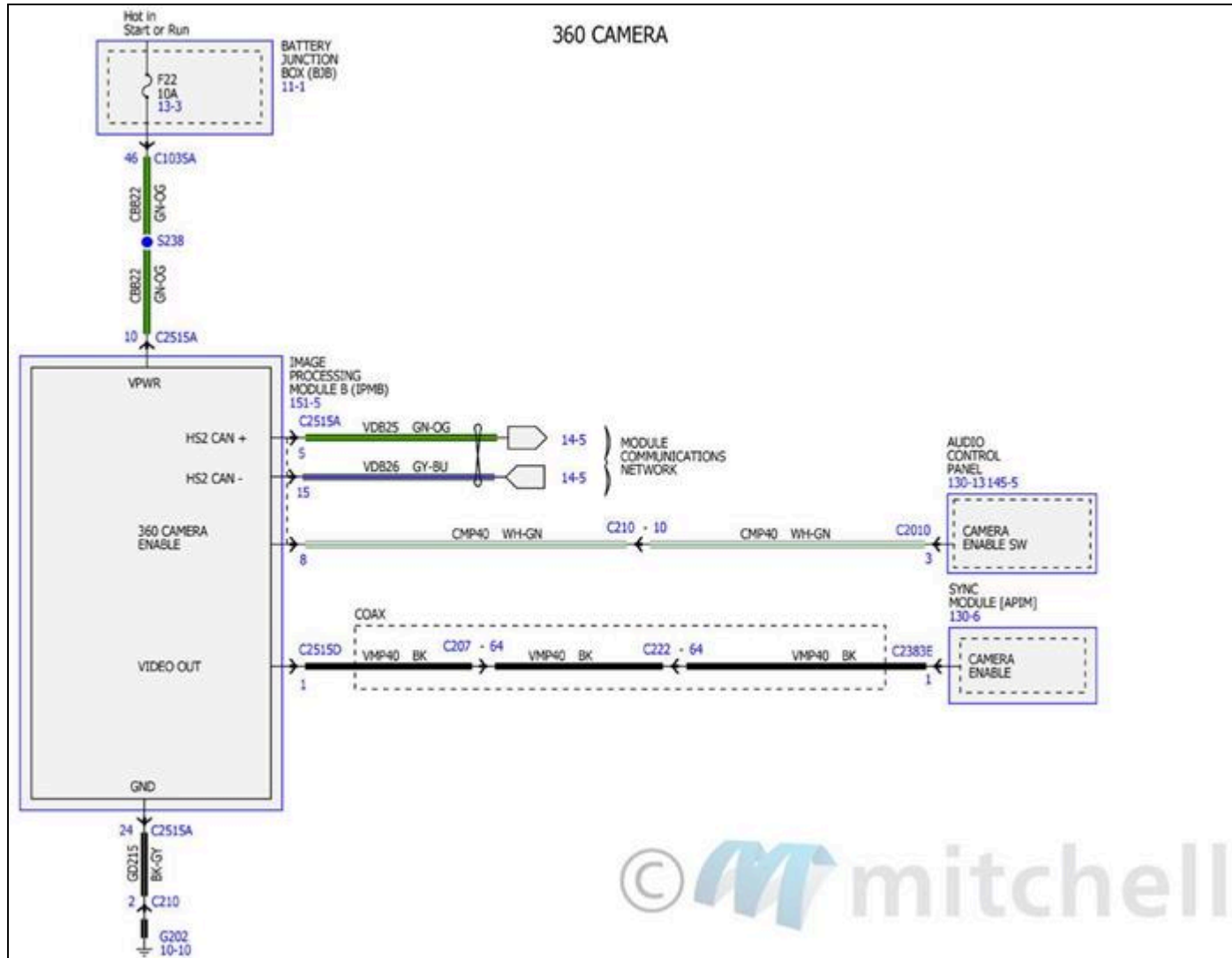

Fig. 223: Diagramas de cableado del sistema de mensajería de emergencia del vehículo (6 de 8)

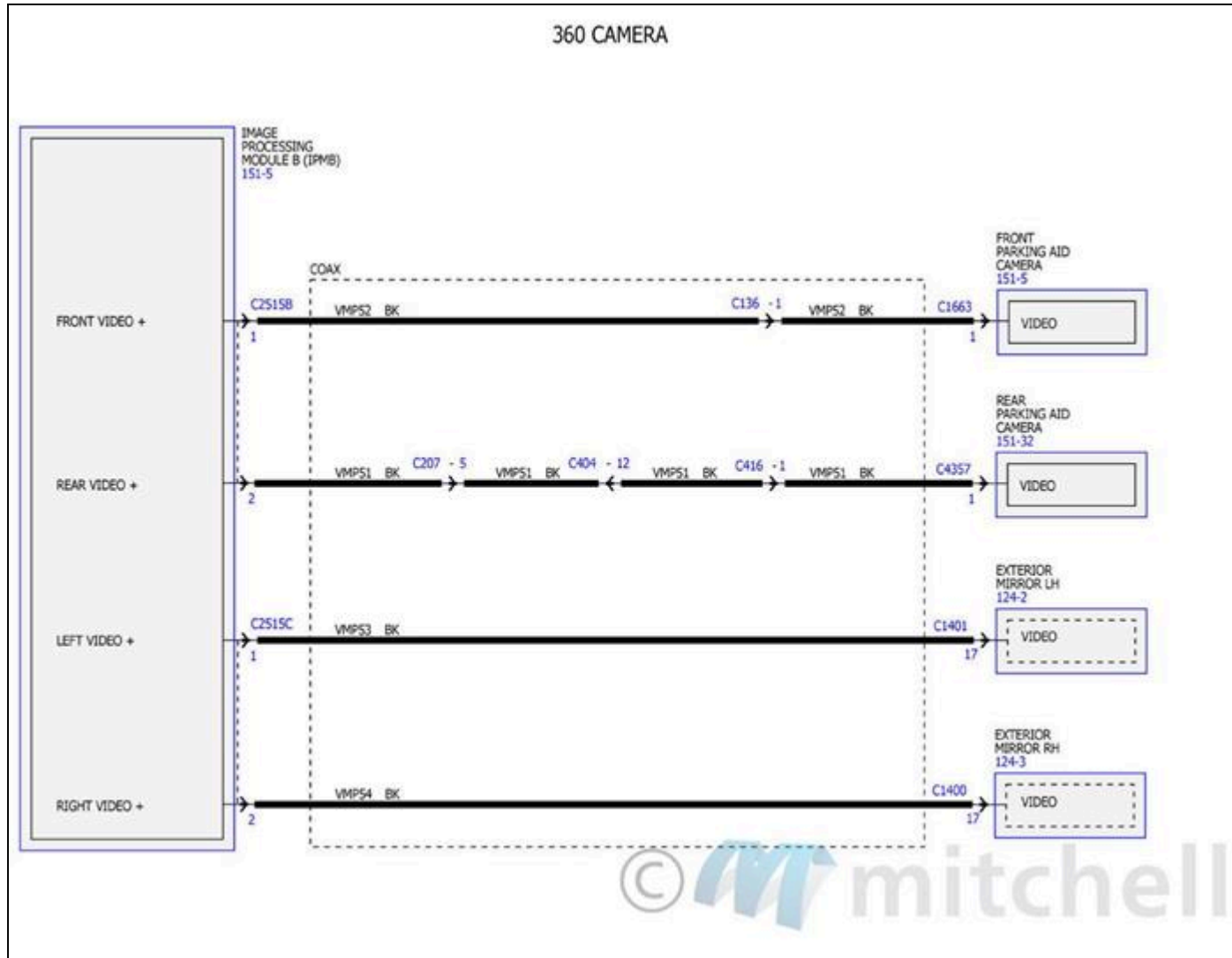

Fig. 224: Diagramas de cableado del sistema de mensajería de emergencia del vehículo (7 de 8)

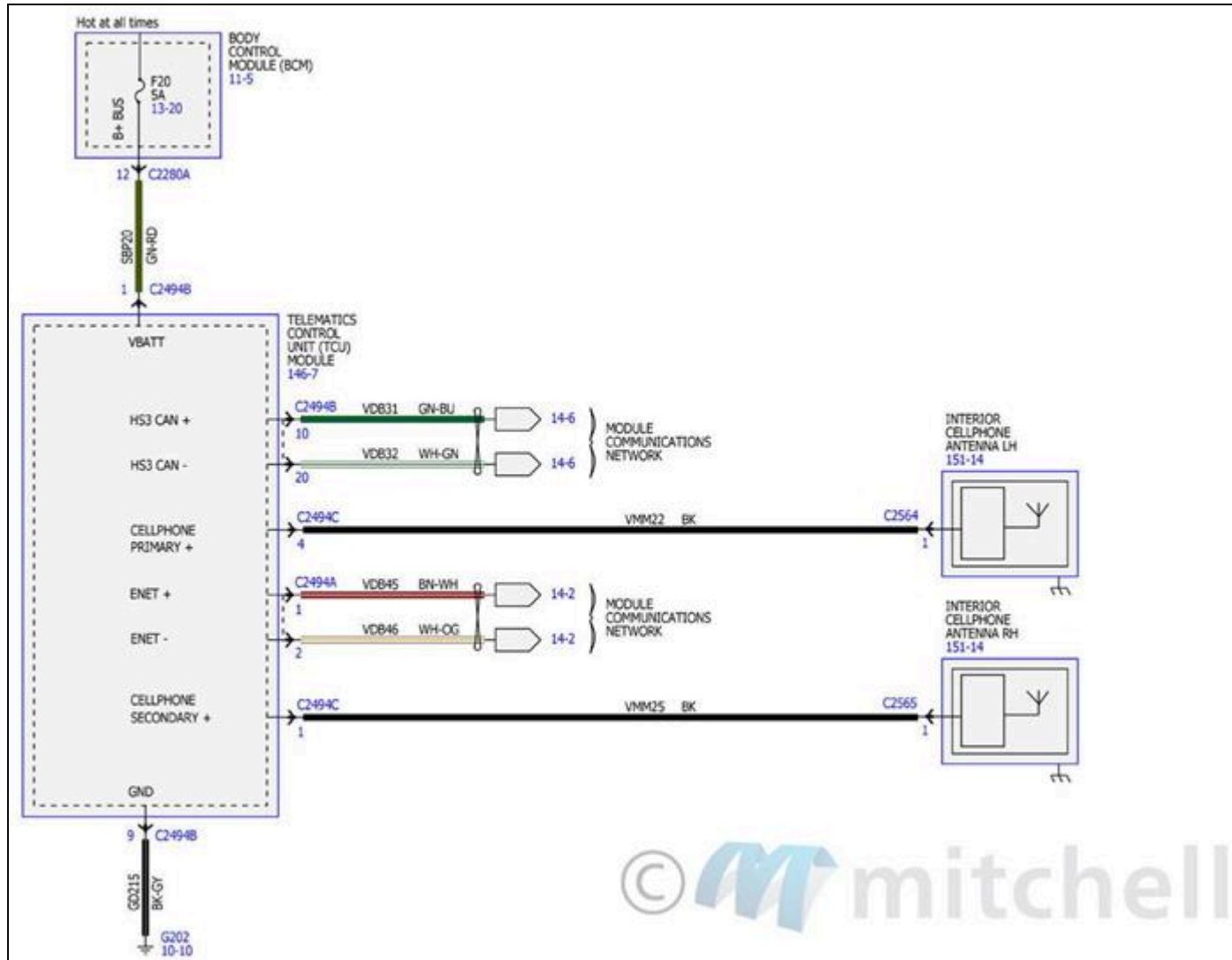
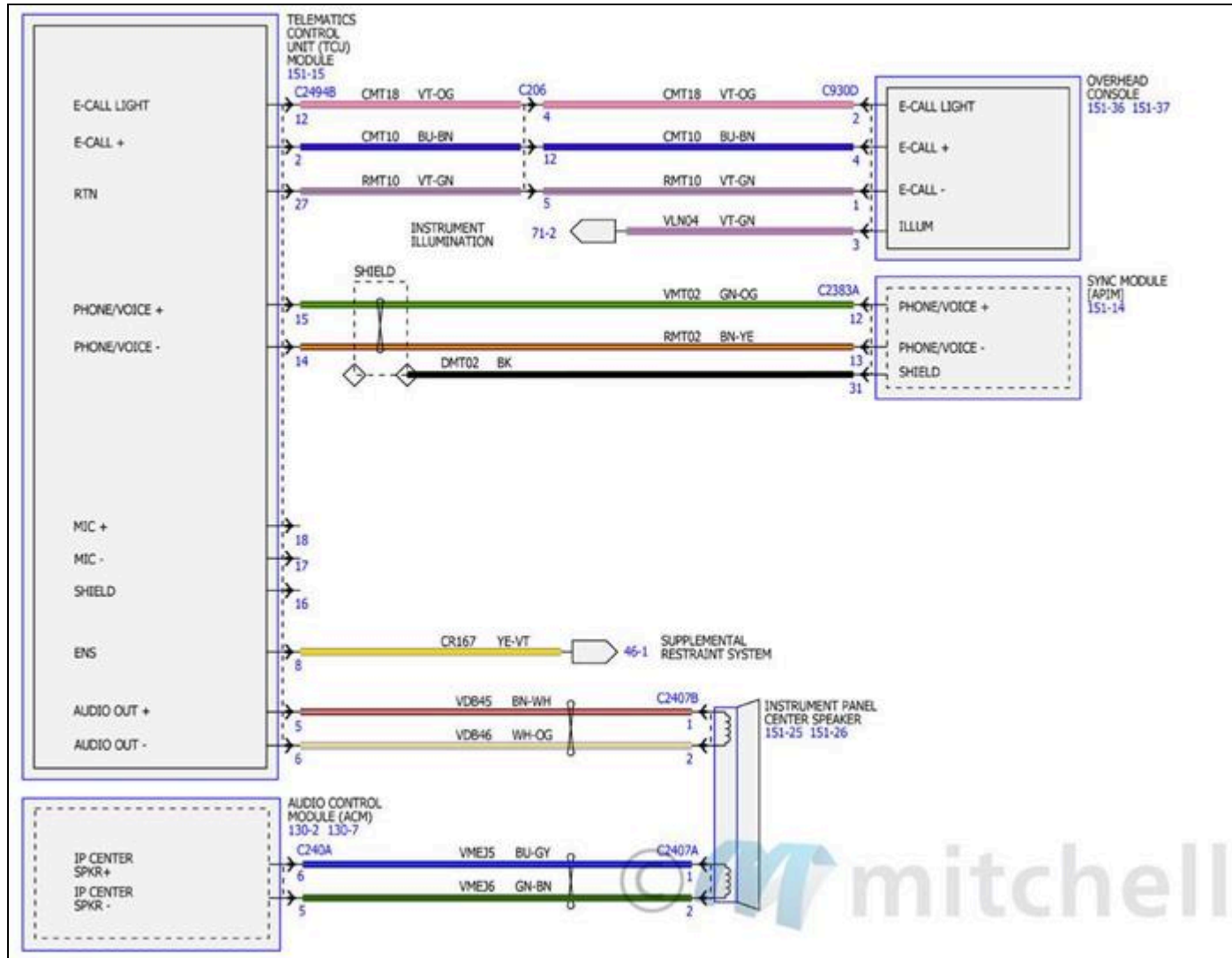

Fig. 225: Diagramas de cableado del sistema de mensajería de emergencia del vehículo (8 de 8)



LIMPIAPARABRISAS Y LAVAPARABRISAS

Fig. 226: Diagramas de cableado de limpiaparabrisas y lavaparabrisas (1 de 3)

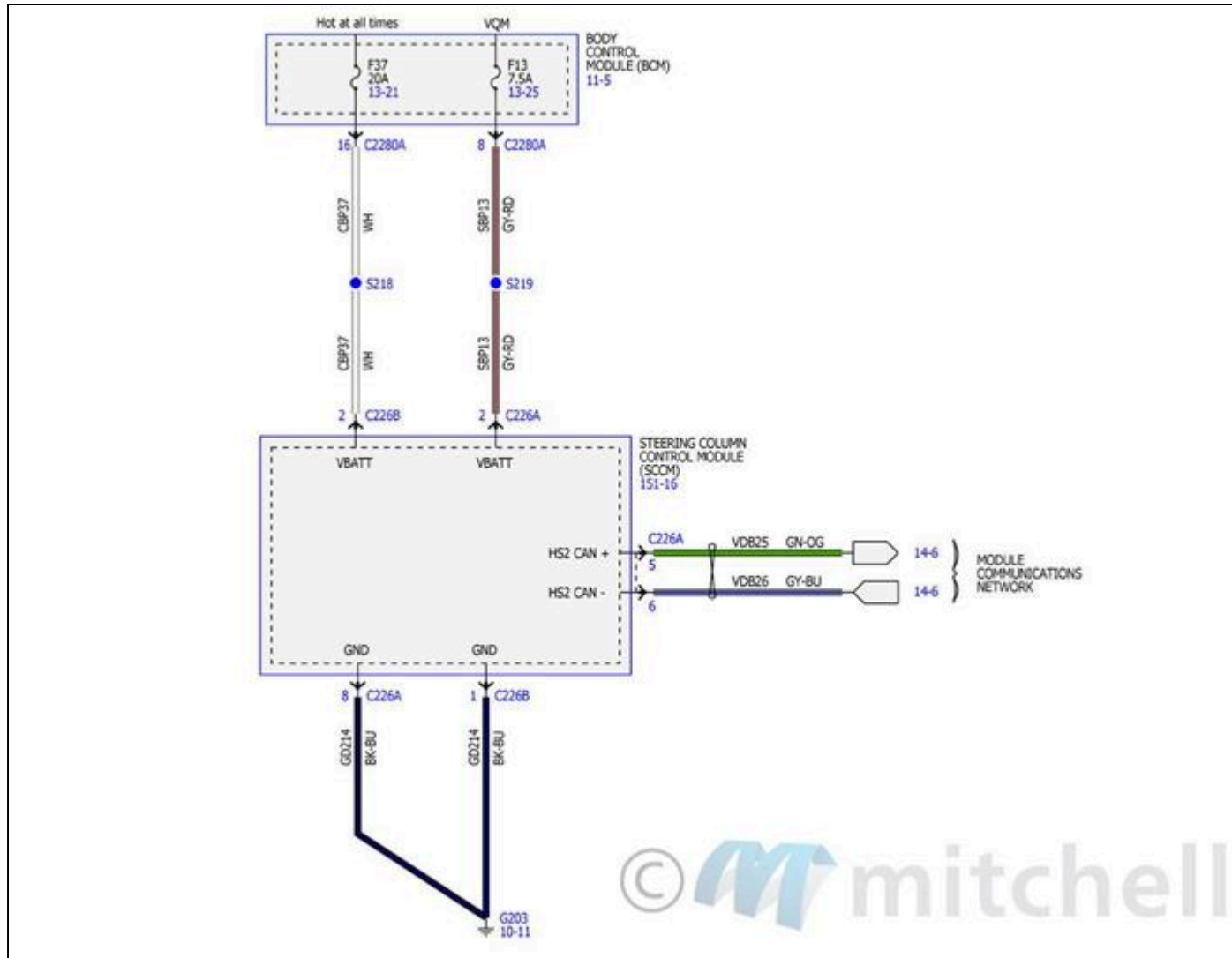

Fig. 227: Diagramas de cableado de limpiaparabrisas y lavaparabrisas (2 de 3)

