

**2008 Hyundai Sonata Limited**

2008 ENGINE Engine (G6DB-GSL 3.3) - Sonata

**2008 ENGINE**

**Engine (G6DB-GSL 3.3) - Sonata**

**GENERAL**

**SPECIFICATION**

**GENERAL SPECIFICATION**

Description		Specifications		Limit
<b>General</b>				
Type		V-type, DOHC		
Number of cylinders		6		
Bore		92 mm (3.6220 in)		
Stroke		83.8 mm (3.2992 in)		
Total displacement		3,342 cc (203.86 cu. in)		
Compression ratio		10.4		
Firing order		1-2-3-4-5-6		
<b>Valve timing</b>				
Intake	Opens (ATDC)	14°		
	Closes (ABDC)	62°		
Exhaust	Opens (BBDC)	42°		
	Closes (ATDC)	6°		
<b>Cylinder head</b>				
Flatness of gasket surface		Less than 0.05 mm (0.0019 in) [Less than 0.02 mm (0.0008 in) / 150 x 150]		
Flatness of manifold mounting	Intake	Less than 0.1 mm (0.0039 in) [Less than 0.03 mm (0.001 in)/110 x 110]		
	Exhaust	Less than 0.1 mm (0.0039 in) [Less than 0.03 mm (0.001 in)/110 x 110]		
<b>Camshaft</b>				
Cam height	LH Camshaft	Intake	46.3 mm	
		Exhaust	45.8 mm	
	RH Camshaft	Intake	46.3 mm	
		Exhaust	45.8 mm	
Journal outer diameter	LH.RH camshaft	Intake	No. 1: 27.964 ~ 27.980 mm (1.1009 ~ 1.1016 in) No. 2,3,4: 23.954 ~ 23.970 mm (0.9430 ~ 0.9437 in)	
		Exhaust	No. 1: 27.964 ~ 27.980 mm	

## 2008 Hyundai Sonata Limited

2008 ENGINE Engine (G6DB-GSL 3.3) - Sonata

			(1.1009 ~ 1.1016 in) No. 2,3,4: 23.954 ~ 23.970 mm (0.9430 ~ 0.9437 in)	
Bearing oil clearance	LH, RH camshaft	Intake	No. 1: 0.020 ~ 0.057 mm (0.0008 ~ 0.0022 in) No. 2,3,4: 0.030 ~ 0.067 mm (0.0012 ~ 0.0026 in)	
		Exhaust	No. 1: 0.020 ~ 0.057 mm (0.0008 ~ 0.0022 in) No. 2,3,4: 0.030 ~ 0.067mm (0.0012 ~ 0.0026 in)	
End play			0.056 ~ 0.064 mm (0.0022 ~ 0.0025 in)	
<b>Valve</b>				
Valve length	Intake		105.27 mm (4.1445 in)	
	Exhaust		105.50 mm (4.1535 in)	
Stem outer diameter	Intake		5.465 ~ 5.480 mm (0.2151 ~ 0.2157 in)	
	Exhaust		5.458 ~ 5.470 mm (0.2149 ~ 0.2153 in)	
Face angle			45.25° ~ 45.75°	
Thickness of valvehead (margin)	Intake		1.56 ~ 1.86 mm (0.06142 ~ 0.07323 in)	
	Exhaust		1.73 ~ 2.03 mm (0.06811 ~ 0.07992 in)	
Valve stem to valve guide clearance	Intake		0.020 ~ 0.047 mm (0.00078 ~ 0.00185 in)	0.07mm (0.00275 in)
	Exhaust		0.030 ~ 0.054 mm (0.00118 ~ 0.00212 in)	0.09 mm (0.00354 in)
<b>Valve guide</b>				
Inner diameter	Intake		5.500 ~ 5.512 mm (0.2165 ~ 0.2170 in)	
	Exhaust		5.500 ~ 5.512 mm (0.2165 ~ 0.2170 in)	
Length	Intake		41.8 ~ 42.2 mm (1.6457 ~ 1.6614 in)	
	Exhaust		41.8 ~ 42.2 mm (1.6457 ~ 1.6614 in)	
<b>Valve seat</b>				
Width of seat contact	Intake		1.15 ~ 1.45 mm (0.05118 ~ 0.05709 in)	
	Exhaust		1.35 ~ 1.65 mm (0.05315 ~ 0.06496 in)	
Seat angle	Intake		44.75° ~ 45.10°	
	Exhaust		44.75° ~ 45.10°	
<b>Valve spring</b>				

## 2008 Hyundai Sonata Limited

2008 ENGINE Engine (G6DB-GSL 3.3) - Sonata

Free length		43.86 mm (1.7267 in)	
Load		19.3 ± 0.8 kg/34.0 mm (42.7 ± 1.8 lb/1.3386 in)	
		42.3 ± 1.3kg/24.2 mm (93.3 ± 2.9 lb/0.9527 in)	
Out of squareness		Less than 1.5°	
<b>MLA</b>			
MLA outer diameter	Intake	34.964 ~ 34.980 mm (1.3765 ~ 1.3772 in)	
	Exhaust	34.964 ~ 34.980 mm (1.3765 ~ 1.3772 in)	
Cylinder head tappet bore inner diameter	Intake	35.000 ~ 35.025 mm (1.3779 ~ 1.3789 in)	
	Exhaust	35.000 ~ 35.025 mm (1.3779 ~ 1.3789 in)	
MLA to tappet bore clearance	Intake	0.020 ~ 0.061 mm (0.0008 ~ 0.0024 in)	0.07mm (0.0027 in)
	Exhaust	0.020 ~ 0.061 mm (0.0008 ~ 0.0024 in)	0.07mm (0.0027 in)
<b>Valve clearance</b>			
Intake		0.17 ~ 0.23 mm (0.0067 ~ 0.0090 in)	0.10 ~ 0.30mm (0.0039-0.0118 in)
Exhaust		0.27 ~ 0.33 mm (0.0106 ~ 0.0129 in)	0.20 ~ 0.40mm (0.0078~0.0157 in)
<b>Cylinder block</b>			
Cylinder bore		92.00 ~ 92.03 mm (3.6220 ~ 3.6232 in)	
Flatness of gasket surface		Less than 0.05 mm (0.0019 in) [Less than 0.02 mm (0.0008 in)/150 x 150]	
<b>Piston</b>			
Piston outer diameter		91.97 ~ 92.00 mm (3.6209 ~ 3.6220 in)	
Piston to cylinder clearance		0.02 ~ 0.04 mm (0.0008 ~ 0.0016 in)	
Ring groove width	No. 1 ring groove	1.23 ~ 1.25 mm (0.0484 ~ 0.0492 in)	1.26 mm (0.0496 in)
	No. 2 ring groove	1.22 ~ 1.24 mm (0.0480 ~ 0.0488 in)	1.26 mm (0.0496 in)
	Oil ring groove	2.01 ~ 2.03 mm (0.0791 ~ 0.0799 in)	2.05 mm (0.0807 in)
<b>Piston ring</b>			
Side clearance	No. 1 ring	0.04 ~ 0.078 mm (0.0016 ~ 0.0031 in)	0.1 mm (0.004 in)
	No. 2 ring	0.03 ~ 0.07 mm (0.0012 ~ 0.0027 in)	0.1 mm (0.004 in)
	Oil ring	0.06 ~ 0.15mm (0.0024 ~ 0.0059 in)	0.2mm (0.008 in)
End gap	No. 1 ring	0.17 ~ 0.32 mm (0.0067 ~ 0.0126 in)	0.6 mm (0.0236 in)

## 2008 Hyundai Sonata Limited

2008 ENGINE Engine (G6DB-GSL 3.3) - Sonata

	No. 2 ring	0.32 ~ 0.47 mm (0.0126 ~ 0.0185 in)	0.7 mm (0.0275 in)
	Oil ring	0.20 ~ 0.70 mm (0.0078 ~ 0.0275 in)	0.8 mm (0.0315 in)
<b>Piston pin</b>			
	Piston pin outer diameter	23.001 ~ 23.006 mm (0.9055 ~ 0.9057 in)	
	Piston pin hole inner diameter	23.016 ~ 23.021 mm (0.9061 ~ 0.9063 in)	
	Piston pin hole clearance	0.01 ~ 0.02 mm (0.0039 ~ 0.0078 in)	
	Connecting rod small end inner diameter	22.974 ~ 22.985 mm (0.9045 ~ 0.9049 in)	
	Connecting rod small end hole clearance	0.016 ~ 0.032 mm (0.0006 ~ 0.0012 in)	
<b>Connecting rod</b>			
	Connecting rod big end inner diameter	58.000 ~ 58.018 mm (2.2834 ~ 2.2842 in)	
	Connecting rod bearing oil clearance	0.030 ~ 0.048 mm (0.0012 ~ 0.0019 in)	
	Side clearance	0.1 ~ 0.25 mm (0.0039 ~ 0.0098 in)	
<b>Crankshaft</b>			
	Main journal outer diameter	68.942 ~ 68.960 mm (2.7142 ~ 2.7149 in)	
	Pin journal outer diameter	54.954 ~ 54.972 mm (2.1635 ~ 2.1642 in)	
	Main bearing oil clearance	0.022 ~ 0.040 mm (0.0008 ~ 0.0016 in)	
	End play	0.10 ~ 0.28 mm (0.0039 ~ 0.0110 in)	
<b>Oil pump</b>			
	Relief valve opening pressure	450 ~ 550 kPa (4.59 ~ 5.61 kgf/cm <sup>2</sup> , 65.28 ~ 79.79 psi)	
<b>Engine oil</b>			
	Oil quantity (Total)	5.9L (6.23 U.S. qts, 5.19 Imp.qts)	
	Oil quantity (Oil pan)	5.5L (5.81 U.S. qts, 4.84 Imp.qts)	
	Oil quantity (Oil filter)	0.4L (0.42 U.S. qts, 0.35 Imp.qts)	
	Oil quality	Above SJ or SL	
	Oil pressure	130 kPa (1.32 kgf/cm <sup>2</sup> , 18.77 psi) [at 1000 rpm, 110°C (230°F)]	
<b>Cooling system</b>			
	Cooling method	Forced circulation with electrical fan	
	Coolant quantity	8.9L (9.40 U.S. qts, 7.83 Imp.qts)	
Thermostat	Type	Wax pellet type	
	Opening temperature	82 ± 2°C (179.6 ± 35.6°F)	
	Fully opened temperature	95°C (203°F)	

## 2008 Hyundai Sonata Limited

2008 ENGINE Engine (G6DB-GSL 3.3) - Sonata

	Full lift	10 mm (0.3937 in)	
Radiator cap	Main valve opening pressure	93.16 ~ 122.58 kpa (0.95 ~ 1.25 kg/cm <sup>2</sup> , 13.51 ~ 17.78 psi)	
	Vacuum valve opening pressure	0.98 ~ 4.90 kpa (0.01 ~ 0.05 kg/cm <sup>2</sup> , 0.14 ~ 0.71 psi)	
<b>Water temperature sensor</b>			
Type		Thermister type	
Resistance	20°C (68°F)	2.31 ~ 2.59 Kohms	
	80°C (176°F)	0.3222 Kohms	

### TIGHTENING TORQUE

#### TIGHTENING TORQUE SPECIFICATION

Item	Quantity	Nm	kgf.m	lbf.ft
Crankshaft pulley bolt	1	284.2 ~ 303.8	29.0~31.0	209.76 ~ 224.22
Timing chain cover bolt B	17	18.62~21.56	1.9 ~2.2	13.74~ 15.91
Timing chain cover bolt C	4	9.80~ 11.76	1.0 ~ 1.2	7.23 ~ 8.68
Timing chain cover bolt D	1	58.80 ~ 68.80	6.0 ~ 7.0	43.40 ~ 50.63
Timing chain cover bolt E	1	58.80 ~ 68.80	6.0 ~ 7.0	43.40 ~ 50.63
Timing chain cover bolt F	2	24.50 ~ 26.46	2.5 ~ 2.7	18.08~ 19.53
Timing chain cover bolt G	4	21.56~23.52	2.2 ~ 2.4	15.91 ~ 17.36
Timing chain cover bolt H	1	9.80~ 11.76	1.0~1.2	7.23 ~ 8.68
Timing chain cover bolt I	1	9.80 ~ 11.76	1.0~1.2	7.23 ~ 8.68
Timing chain cover bolt J	1	9.80~ 11.76	1.0 ~ 1.2	7.23 ~ 8.68
Cam to cam guide bolt	4	9.80~ 11.76	1.0~ 1.2	7.23 ~ 8.68
Timing chain auto tensioner bolt	2	9.80 ~ 11.76	1.0~1.2	7.23 ~ 8.68
Timing chain auto tensioner nut	2	9.80~11.76	1.0~1.2	7.23 ~ 8.68
Timing chain tensioner arm bolt	2	18.62~21.56	1.9~2.2	13.74~ 15.91
Timing chain guide bolt	4	19.60~24.50	2.0 ~ 2.5	14.17~ 18.08

## 2008 Hyundai Sonata Limited

2008 ENGINE Engine (G6DB-GSL 3.3) - Sonata

Oil pump chain cover bolt	3	9.80 ~ 11.76	1.0~1.2	7.23 ~ 8.68
Oil pump chain tensioner bolt	1	9.80~ 11.76	1.0 ~ 1.2	7.23 ~ 8.68
Oil pump chain guide bolt	2	9.80~ 11.76	1.0~ 1.2	7.23 ~ 8.68
Oil pump chain sprocket bolt	1	18.62~21.56	1.9 ~2.2	13.74~ 15.91
Lower oil pan bolt	13	9.80~ 11.76	1.0 ~ 1.2	7.23 ~ 8.68
Drive belt auto tensioner bolt(M12)	1	96.04 ~ 99.96	9.8 ~ 10.2	70.88 ~ 73.78
Drive belt auto tensioner bolt(M8)	1	17.64~21.56	1.8~2.2	13.02~15.91
Drive belt idler bolt	1	53.90 ~ 57.82	5.5 ~ 5.9	39.78 ~ 42.67
OCV(oil control valve) bolt	2	9.80~ 11.76	1.0~ 1.2	7.23 ~ 8.68
Cylinder head bolt	16	39.2+ 120°+ 90°	4.0+ 120°+ 90°	28.93+120°+ 90°
Cylinder head bolt	1	18.62~23.52	1.9 ~2.4	13.74~ 17.36
CVVT & exhaust cam sprocket bolt	4	64.68 ~ 76.44	6.6 ~ 7.8	47.74 ~ 56.42
Camshaft bearing cap bolt	32	9.80~ 11.76	1.0 ~ 1.2	7.23 ~ 8.68
Cylinder head cover bolt	38	9.80 ~ 11.76	1.0 ~ 1.2	7.23 ~ 8.68
Connecting rod bearing bolt	12	19.60 + 90°	2.0 + 90°	14.46 + 90°
Main bearing cap bolt	8	49.00 + 90°	5.0 + 90°	36.16 + 90°
Main bearing cap bolt	8	19.60 + 120°	2.0 + 120°	14.46 + 120°
Main bearing cap bolt	6	29.40~31.36	3.0 ~ 3.2	21.70~23.14
Oil drain cover bolt	6	9.80 ~ 11.76	1.0~1.2	7.23 ~ 8.68
Rear oil seal case bolt	6	9.80~ 11.76	1.0~ 1.2	7.23 ~ 8.68
Baffle plate bolt	12	9.80~ 11.76	1.0~1.2	7.23 ~ 8.68
Upper oil pan bolt	16	9.80~ 11.76	1.0 ~ 1.2	7.23 ~ 8.68
Knock sensor bolt	2	15.68~23.52	1.6 ~2.4	11.57~ 17.36
Drive plate bolt	8	71.54~75.46	7.3 ~ 7.7	52.80 ~ 55.69
Oil filter		24.50	2.5	18.08
Oil drain bolt	1	34.30~44.10	3.5 ~ 4.5	25.31 ~ 32.55
Oil pump bolt	3	19.60~23.52	2.0 ~ 2.4	14.47~17.36
Oil filter body bolt	10	9.80~ 11.76	1.0~ 1.2	7.23 ~ 8.68

**2008 Hyundai Sonata Limited**

2008 ENGINE Engine (G6DB-GSL 3.3) - Sonata

Oil filter body cover bolt	11	9.80~ 11.76	1.0~ 1.2	7.23 ~ 8.68
Water vent hose bolt	2	9.80~ 11.76	1.0~ 1.2	7.23 ~ 8.68
Water pump bolt	6	21.56~23.52	2.2 ~ 2.4	15.91 ~ 17.36
Water pump bolt	6	9.80~ 11.76	1.0 ~ 1.2	7.23 ~ 8.68
Water pump pulley bolt	4	7.84 ~ 9.80	0.8~ 1.0	5.78 ~ 7.23
Water temp, control nut	6	18.62~23.52	1.9~2.4	13.74~ 17.36
Water inlet pipe bolt	3	16.66~19.60	1.7~2.0	12.30~ 14.47
Air vent pipe bolt	2	9.80~ 11.76	1.0 ~ 1.2	7.23 ~ 8.68
Intake manifold bolt	6	18.62~23.52	1.9 ~2.4	13.74~17.36
Intake manifold nut	2	18.62~23.52	1.9~2.4	13.74~17.36
Surge tank bolt	5	9.80~ 11.76	1.0~ 1.2	7.23 ~ 8.68
Surge tank nut	2	9.80~ 11.76	1.0 ~ 1.2	7.23 ~ 8.68
Breather pipe bolt	2	9.80 ~ 11.76	1.0 ~ 1.2	7.23 ~ 8.68
Surge tank bracket bolt	2	27.44~31.36	2.8 ~ 3.2	20.25 ~ 23.14
ETC bracket bolt	2	15.68~25.48	1.6 ~ 2.6	11.57~18.80
Exhaust manifold nut	16	39.20~44.10	4.0 ~ 4.5	28.93 ~ 32.55
Heat proctor bolt	8	16.66~21.56	1.7 ~2.2	12.30~ 15.91
Front muffler	2	39.20 ~ 58.80	4.0 ~ 6.0	28.93 ~ 43.40

**COMPRESSION**

**NOTE:** If the there is lack of power, excessive oil consumption or poor fuel economy, measure the compression pressure.

1. Warm up and stop engine.

Allow the engine to warm up to normal operating temperature.

2. Remove ignition coils. (See **IGNITION** )
3. Remove spark plugs.

Using a 16 mm plug wrench, remove the 6 spark plugs.

4. Check cylinder compression pressure.
  - a. Insert a compression gauge into the spark plug hole.
  - b. Fully open the throttle.
  - c. While cranking the engine, measure the compression pressure.

**NOTE:** Always use a fully charged battery to obtain engine speed of 200 rpm or more.

- d. Repeat steps (a) through (c) for each cylinder.

**NOTE:** This measurement must be done in as short a time as possible.

Compression pressure: 1,283 kPa (13.0 kgf/cm<sup>2</sup> , 185 psi)

Minimum pressure: 1,135 kPa (11.5 kgf/cm<sup>2</sup> , 164 psi)

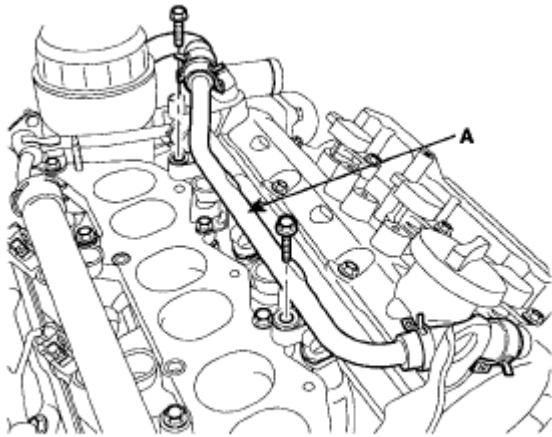
Difference between each cylinder: 100 kPa (1.0 kgf/cm<sup>2</sup> , 15 psi) or less

- e. If the cylinder compression in 1 or more cylinders is low, pour a small amount of engine oil into the cylinder through the spark plug hole and repeat steps (a) through (c) for cylinders with low compression.
- If adding oil helps the compression, it is likely that the piston rings and/or cylinder bore are worn or damaged.
  - If pressure stays low, a valve may be sticking or seating is improper, or there may be leakage past the gasket.
5. Reinstall spark plugs.
6. Install ignition coils. (See **IGNITION** )

## VALVE CLEARANCE INSPECTION AND ADJUSTMENT

**NOTE:** Inspect and adjust the valve clearance when the engine is cold (Engine coolant temperature: 20°C) and cylinder head is installed on the cylinder block.

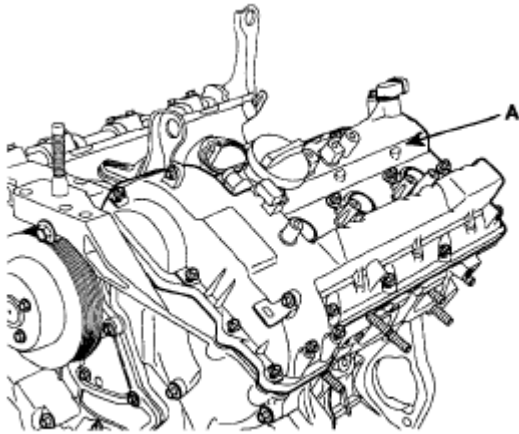
1. Remove the engine cover.
2. Remove air cleaner assembly. (See **REMOVAL**)
3. Remove the surge tank. (See **REMOVAL**)
4. Remove the cylinder head cover.
  - a. Disconnect the ignition coil connector and remove the ignition coil.
  - b. Disconnect the breather hose (A) from the cylinder head cover.



KDRF180A

**Fig. 1: Identifying Breather Hose**  
Courtesy of HYUNDAI MOTOR CO.

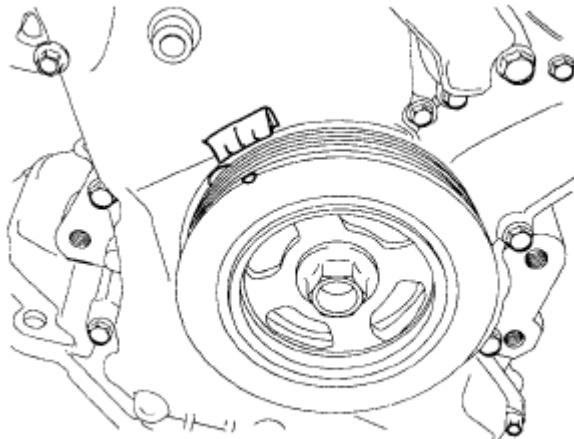
- c. Loosen the cylinder head cover bolts and then remove the cover (A) and gasket.



KDRF112A

**Fig. 2: Identifying Cylinder Head Cover**  
Courtesy of HYUNDAI MOTOR CO.

5. Set No.1 cylinder to TDC/compression.
  - a. Turn the crankshaft pulley and align its groove with the timing mark "T" of the lower timing chain cover.

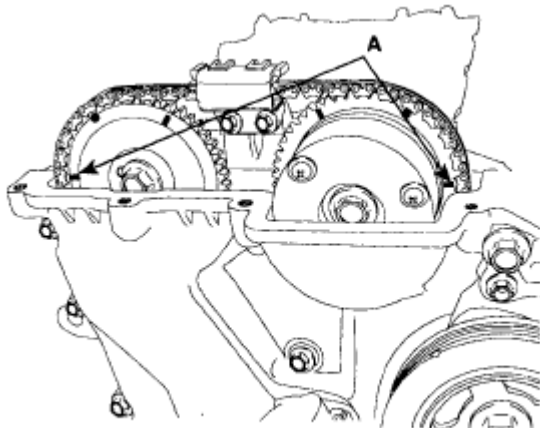


KDRF108A

**Fig. 3: Aligning Groove With Timing Mark "T" Of Lower Timing Chain Cover**  
Courtesy of HYUNDAI MOTOR CO.

- b. Check that the mark (A) of the camshaft timing sprockets are in straight line on the cylinder head surface as shown in the illustration. If not, turn the crankshaft one revolution (360°)

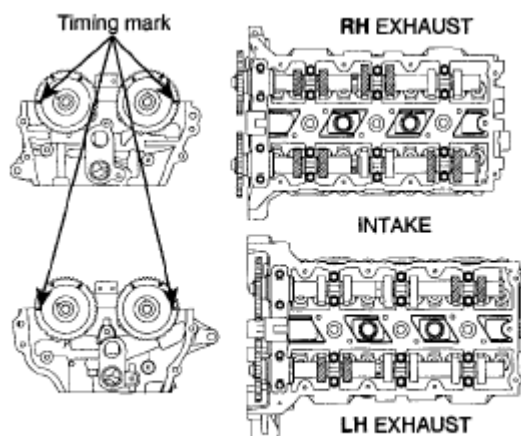
**NOTE: Do not rotate engine counterclockwise**



KDRF113A

**Fig. 4: Identifying Mark On Camshaft Sprockets**  
Courtesy of HYUNDAI MOTOR CO.

6. Inspect the valve clearance.
  - a. Check only the valve indicated as shown. [No. 1 cylinder: TDC/Compression] measure the valve clearance.



EDRF021A

**Fig. 5: Measuring Valve Clearance (No. 1 Cylinder)**  
 Courtesy of HYUNDAI MOTOR CO.

- Using a thickness gauge, measure the clearance between the tappet and the base circle of camshaft.
- Record the out-of-specification valve clearance measurements. They will be used later to determine the required replacement adjusting tappet.

Valve clearance

Specification

Engine coolant temperature: 20°C [68°F]

Limit

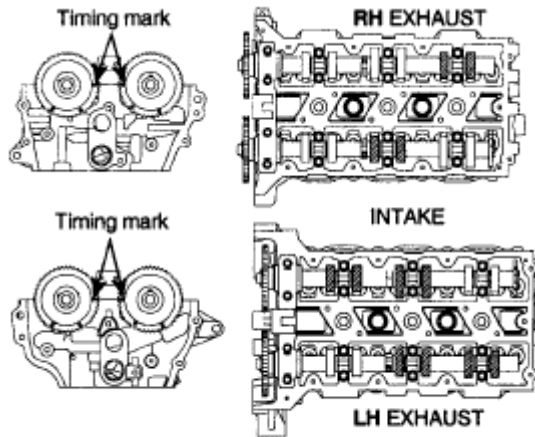
Intake: 0.10 ~ 0.30 mm (0.0039 ~ 0.0118 in)

Exhaust: 0.20 ~ 0.40 mm (0.0079 ~ 0.0157 in)

- Turn the crankshaft pulley one revolution (360°) and align the groove with timing mark "T" of the lower timing chain cover.

**NOTE:** Do not rotate engine counterclockwise

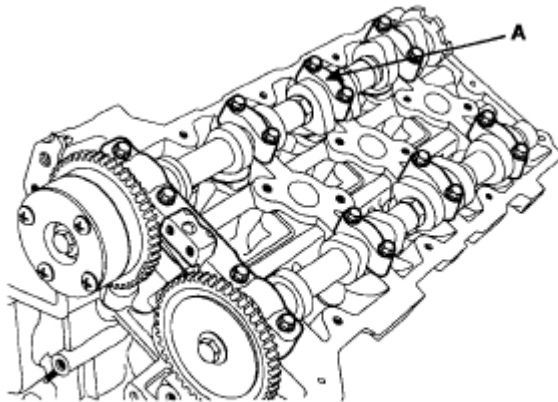
- Check only valves indicated as shown. [NO. 4 cylinder: TDC/compression]. Measure the valve clearance.



EDRF022A

**Fig. 6: Measuring Valve Clearance (No. 4 Cylinder)**  
 Courtesy of HYUNDAI MOTOR CO.

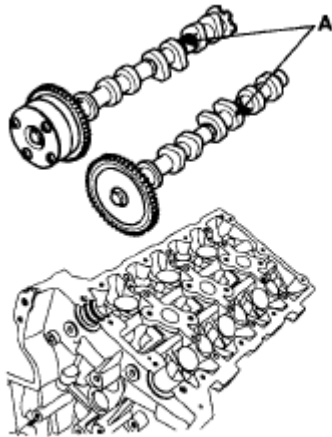
7. Adjust the intake and exhaust valve clearance.
  - a. Set the No.1 cylinder to the TDC/compression. (See VALVE CLEARANCE INSPECTION AND ADJUSTMENT)
  - b. Remove the timing chain. (See REMOVAL)
  - c. Remove the camshaft bearing caps (A).



KDRF196A

**Fig. 7: Identifying Camshaft Bearing Caps**  
 Courtesy of HYUNDAI MOTOR CO.

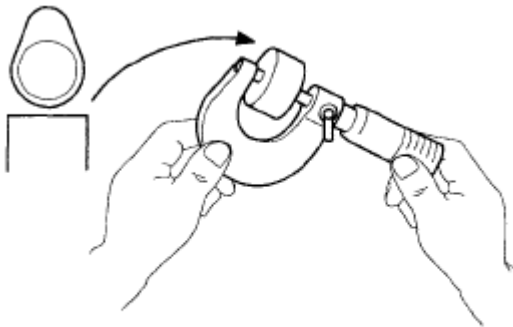
- d. Remove the camshaft assembly (A).



KDRF197A

**Fig. 8: Identifying Camshaft Assembly**  
Courtesy of HYUNDAI MOTOR CO.

- e. Remove MLAs.
- f. Measure the thickness of the removed tappet using a micrometer.



EDKE889D

**Fig. 9: Measuring Thickness Of Tappet**  
Courtesy of HYUNDAI MOTOR CO.

- g. Calculate the thickness of a new tappet so that the valve clearance comes within the specified value.

Valve clearance (Engine coolant temperature: 20°C [68°F])

T: Thickness of removed tappet

A: Measured valve clearance

N: Thickness of new tappet

Intake:  $N = T + [A - 0.20 \text{ mm (0.0079 in)}]$

Exhaust:  $N = T + [A - 0.30 \text{ mm (0.0118 in)}]$

- h. Select a new tappet with a thickness as close as possible to the calculated value.

**NOTE:** Shims are available in 41 size increments of 0.015 mm (0.0006 in) from 3.00 mm (0.118 in) to 3.600 mm (0.1417 in)

- i. Place a new tappet on the cylinder head.

**NOTE:** Applying engine oil at the selected tappet on the periphery and top surface.

- j. Install the intake and exhaust camshaft. (See **INSTALLATION**)
- k. Install the bearing caps. (See **INSTALLATION**)
- l. Install the timing chain. (See **INSTALLATION**)
- m. Turn the crankshaft two turns in the operating direction (clockwise) and realign crankshaft sprocket and camshaft sprocket timing marks.
- n. Recheck the valve clearance.

Valve clearance (Engine coolant temperature: 20°C [68°F]) [Specification]

Intake: 0.17 ~ 0.23 mm (0.0067 ~ 0.0090 in)

Exhaust: 0.27 ~ 0.33 mm (0.0106 ~ 0.0129 in)

**TROUBLESHOOTING**

**TROUBLESHOOTING CHART**

Symptom	Suspect area	Remedy
Engine misfire with abnormal internal lower engine noises.	Worn crankshaft bearings. Loose or improperly engine drive plate	Replace the crankshaft and bearings as required. Repair or replace the drive plate as required.
	Worn piston rings. (Oil consumption may or may not cause the engine to misfire.)	Inspect the cylinder for a loss of compression. Repair or replace as required.
	Worn crankshaft thrust bearings	Replace the crankshaft and bearings as required.
Engine misfire with abnormal valve train noise.	Stuck valves. (Carbon buildup on the valve stem)	Repair or replace as required.
	Excessive worn or mis-aligned timing chain.	Replace the timing chain and sprocket as required.

## 2008 Hyundai Sonata Limited

2008 ENGINE Engine (G6DB-GSL 3.3) - Sonata

	Worn camshaft lobes.	Replace the camshaft and valve lifters.
Engine misfire with coolant consumption.	<ul style="list-style-type: none"> <li>Faulty cylinder head gasket and/or cranking or other damage to the cylinder head and engine block cooling system.</li> <li>Coolant consumption may or may not cause the engine to overheat.</li> </ul>	<ul style="list-style-type: none"> <li>Inspect the cylinder head and engine block for damage to the coolant passages and/or a faulty head gasket.</li> <li>Repair or replace as required.</li> </ul>
Engine misfire with excessive oil consumption.	Worn valves, guides and/or valve stem oil seals.	Repair or replace as required.
	Worn piston rings. (Oil consumption may or may not cause the engine to misfire)	<ul style="list-style-type: none"> <li>Inspect the cylinder for a loss of compression.</li> <li>Repair or replace as required.</li> </ul>
Engine noise on start-up, but only lasting a few seconds.	Incorrect oil viscosity.	<ul style="list-style-type: none"> <li>Drain the oil.</li> <li>Install the correct viscosity oil.</li> </ul>
	Worn crankshaft thrust bearing.	<ul style="list-style-type: none"> <li>Inspect the thrust bearing and crankshaft.</li> <li>Repair or replace as required.</li> </ul>
Upper engine noise, regardless of engine speed.	Low oil pressure.	Repair or replace as required.
	Broken valve spring.	Replace the valve spring.
	Worn or dirty valve lifters.	Replace the valve lifters.
	Stretched or broken timing chain and/or damaged sprocket teeth.	Replace the timing chain and sprockets.
	Worn timing chain tensioner, if applicable.	Replace the timing chain tensioner as required.
	Worn camshaft lobes.	<ul style="list-style-type: none"> <li>Inspect the camshaft lobes.</li> <li>Replace the timing camshaft and valve lifters as required.</li> </ul>
	Worn valve guides or valve stems.	Inspect the valves and valve guides, then repair as required.
	Stuck valves. (Carbon on the valve stem or valve seat may cause the valve to stay open.	Inspect the valves and valve guides, then repair as required.
Lower engine noise, regardless of engine speed.	Worn drive belt, idler, tensioner and bearing.	Replace as required.
	Low oil pressure.	Repair or required.
	Loose or damaged drive plate.	Repair or replace the drive plate.

## 2008 Hyundai Sonata Limited

2008 ENGINE Engine (G6DB-GSL 3.3) - Sonata

	Damaged oil pan, contacting the oil pump screen.	<ul style="list-style-type: none"> <li>• Inspect the oil pan.</li> <li>• Inspect the oil pump screen.</li> <li>• Repair or replace as required.</li> </ul>
	Oil pump screen loose, damaged or restricted.	<ul style="list-style-type: none"> <li>• Inspect the oil pump screen.</li> <li>• Repair or replace as required.</li> </ul>
	Excessive piston-to-cylinder bore clearance.	<ul style="list-style-type: none"> <li>• Inspect the piston, piston pin and cylinder bore.</li> <li>• Repair as required.</li> </ul>
	Excessive piston pin-to-piston clearance.	<ul style="list-style-type: none"> <li>• Inspect the piston, piston pin and the connecting rod.</li> <li>• Repair or replace as required.</li> </ul>
	Excessive connecting rod bearing clearance	<p>Inspect the following components and repair as required.</p> <ul style="list-style-type: none"> <li>• The connecting rod bearings.</li> <li>• The connecting rods.</li> <li>• The crankshaft pin journals.</li> </ul>
	Excessive crankshaft bearing clearance.	<p>Inspect the following components, and repair as required.</p> <ul style="list-style-type: none"> <li>• The crankshaft bearings.</li> <li>• The crankshaft main journals.</li> <li>• The cylinder block.</li> </ul>
	Incorrect piston, piston pin and connecting rod installation	<ul style="list-style-type: none"> <li>• Verify the piston pins and connecting rods are installed correctly.</li> <li>• Repair as required.</li> </ul>
Engine noise under load.	Low oil pressure	Repair or replace as required.
	Excessive connecting rod bearing clearance.	<p>Inspect the following components and repair as required:</p> <ul style="list-style-type: none"> <li>• The connecting rod bearings.</li> <li>• The connecting rods.</li> <li>• The crankshaft.</li> </ul>
	Excessive crankshaft bearing	Inspect the following components,

## 2008 Hyundai Sonata Limited

2008 ENGINE Engine (G6DB-GSL 3.3) - Sonata

	clearance.	and repair as required. <ul style="list-style-type: none"> <li>• The crankshaft bearings.</li> <li>• The crankshaft main journals.</li> <li>• The cylinder block.</li> </ul>
Engine will not crank-crankshaft will not rotate	Hydraulically locked cylinder. <ul style="list-style-type: none"> <li>• Coolant/antifreeze in cylinder.</li> <li>• Oil in cylinder.</li> <li>• Fuel in cylinder.</li> </ul>	<ul style="list-style-type: none"> <li>• Remove spark plugs and check for fluid.</li> <li>• Inspect for broken head gasket.</li> <li>• Inspect for cracked engine block or cylinder head.</li> <li>• Inspect for a sticking fuel injector and/or leaking fuel regulator.</li> </ul>
	Broken timing chain and/or timing chain and/or timing chain gears.	<ul style="list-style-type: none"> <li>• Inspect timing chain and gears.</li> <li>• Repair as required.</li> </ul>
	Material in cylinder. <ul style="list-style-type: none"> <li>• Broken valve</li> <li>• Piston material</li> <li>• Foreign material</li> </ul>	<ul style="list-style-type: none"> <li>• Inspect cylinder for damaged components and/or foreign materials.</li> <li>• Repair or replace as required.</li> </ul>
	Seized crankshaft or connecting rod bearings.	<ol style="list-style-type: none"> <li>1. Inspect crankshaft and connecting rod bearing.</li> <li>2. Repair as required.</li> </ol>
	Bent or broken connecting rod.	<ol style="list-style-type: none"> <li>1. Inspect connecting rods.</li> <li>2. Repair as required.</li> </ol>
	Broken crankshaft.	<ol style="list-style-type: none"> <li>1. Inspect crankshaft.</li> <li>2. Repair as required.</li> </ol>

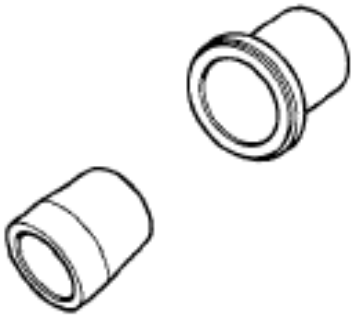
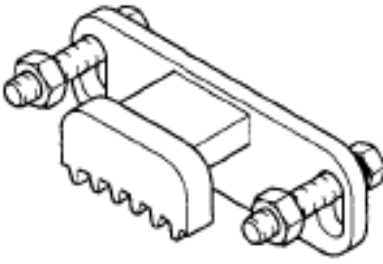
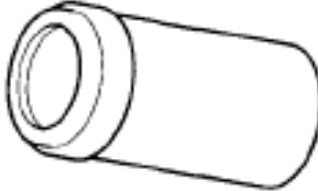
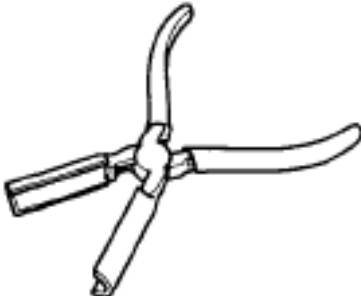
### SPECIAL TOOLS

### SPECIAL TOOLS REFERENCE

Tool (Number and name)	Illustration	Use
Crankshaft front oil seal installer (09231-3C100)		Installation of the front oil seal

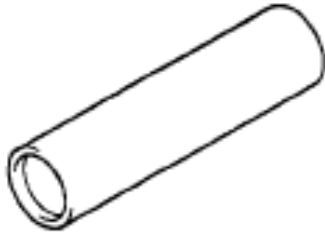
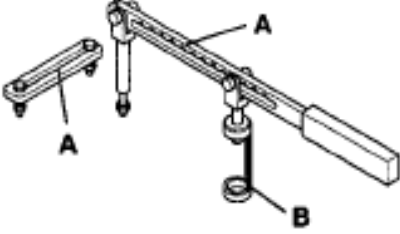
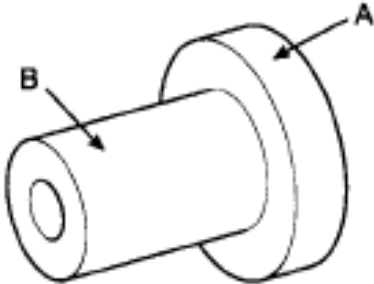

2008 Hyundai Sonata Limited

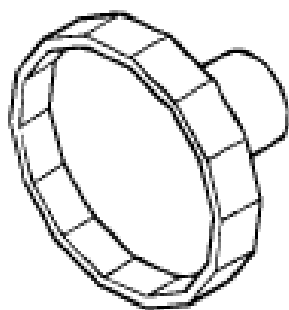
2008 ENGINE Engine (G6DB-GSL 3.3) - Sonata

	 <p>KDRF233A</p>	
<p>Flywheel stopper (09231-3C300)</p>	 <p>KCRF030D</p>	<p>Removal and installation of the flywheel and crankshaft pulley.</p>
<p>Torque angle adapter (09221-4A000)</p>	 <p>EDKA010A</p>	<p>Installation of bolts &amp; nuts needing an angular method</p>
<p>Valve stem seal remover (09222-29000)</p>	 <p>KDRF232A</p>	<p>Remover of the valve stem seal</p>
<p>Valve stem seal installer (09222-3C100)</p>		<p>Installation of the valve stem seal</p>

2008 Hyundai Sonata Limited

2008 ENGINE Engine (G6DB-GSL 3.3) - Sonata

	 <p style="text-align: right;">LCAC0300</p>	
<p>Valve spring compressor &amp; holder (09222-3K000) (09222-3C300)</p>	 <p style="text-align: right;">ECRF003A</p>	<p>Removal and installation of the intake or exhaust valve A: 09222-3K000 B: 09222-3C300 (holder)</p>
<p>Crankshaft rear oil seal installer (09231-3C200) (09231-H1100)</p>	 <p style="text-align: right;">ACRF003A</p>	<p>Installation of the crankshaft rear oil seal A: 09231-3C200 B: 09231-H1100</p>
<p>Oil pan remover (09215-3C000)</p>	 <p style="text-align: right;">KDRF219A</p>	<p>Removal of oil pan</p>
<p>Oil filter wrench (09263-3C100)</p>		<p>Removal and installation of the oil filter</p>



B6327000

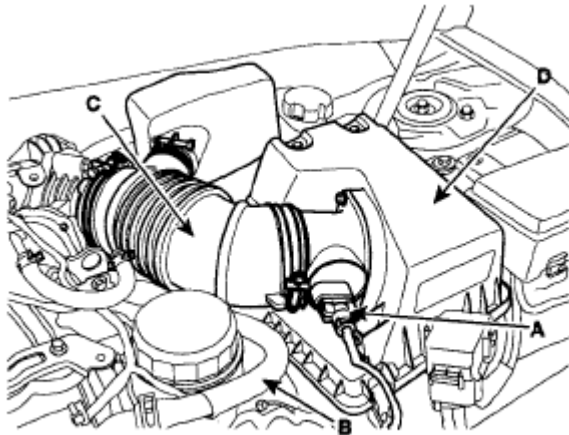
## ENGINE AND TRANSAXLE ASSEMBLY

### REMOVAL

- CAUTION:**
- Use fender covers to avoid damaging painted surfaces.
  - To avoid damage, unplug the wiring connectors carefully while holding the connector portion.

**NOTE:** Mark all wiring and hoses to avoid misconnection.  
Turn the crankshaft pulley so that the No. 1 piston is at top dead center. (See VALVE CLEARANCE INSPECTION AND ADJUSTMENT)

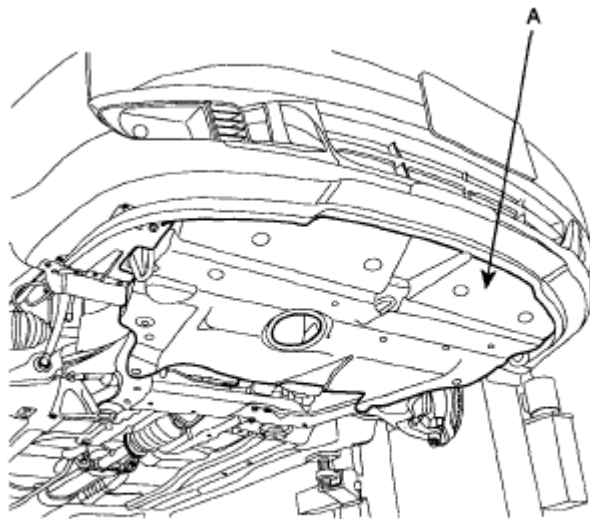
1. Disconnect the negative terminal from the battery.
  2. Remove the engine cover.
  3. Remove the air duct.
  4. Remove the intake air hose and air cleaner assembly.
- 
1. Disconnect the AFS connector (A).
  2. Disconnect the breather hose (B) from air cleaner hose.
  3. Disconnect the ECM(PCM) connector. (See COMPONENT LOCATION ).
  4. Remove the intake air hose (C) and air cleaner (D).



KDRF173A

**Fig. 10: Identifying AFS Connector And Intake Air Hose With Air Cleaner**  
Courtesy of HYUNDAI MOTOR CO.

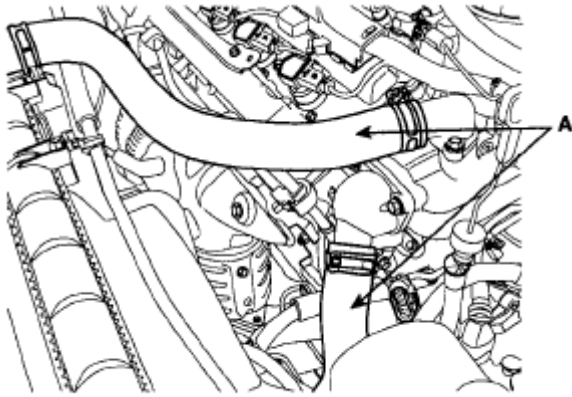
5. Remove front wheels.
6. Remove under cover (A).



KMRE009H

**Fig. 11: Identifying Under Cover**  
Courtesy of HYUNDAI MOTOR CO.

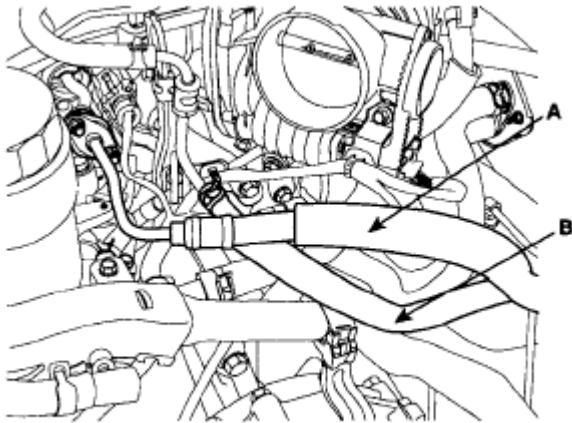
7. Drain the engine coolant.  
Remove the radiator cap to speed draining.
8. Remove the upper radiator hose and lower radiator hose (A).



KDRF148A

**Fig. 12: Identifying Upper And Lower Radiator Hose**  
Courtesy of HYUNDAI MOTOR CO.

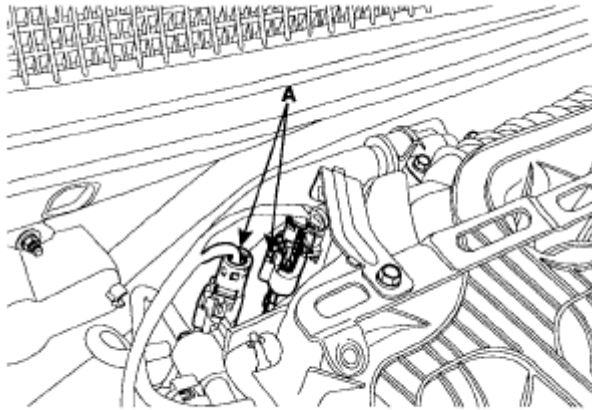
9. Remove transaxle oil cooler hose.
10. Remove fuel hose (A) and PCSV (B) hose.



KDRF149A

**Fig. 13: Identifying Fuel Hose And PCSV Hose**  
Courtesy of HYUNDAI MOTOR CO.

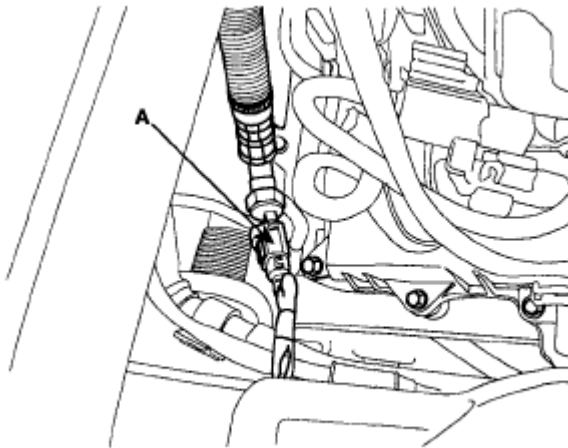
11. Remove engine wiring.
  1. Disconnect RH oxygen sensor connector (A).



KDRF151A

**Fig. 14: Identifying RH Oxygen Sensor Connector**  
Courtesy of HYUNDAI MOTOR CO.

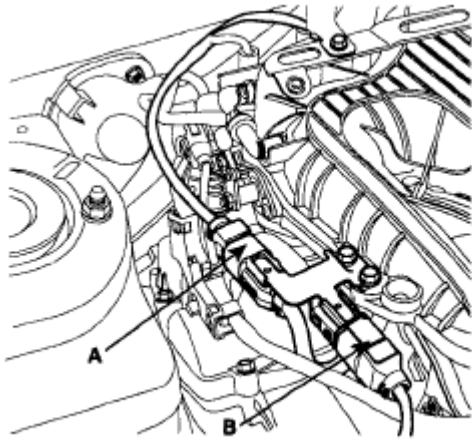
2. Disconnect power steering oil pressure sensor connector (A).



KDRF152A

**Fig. 15: Identifying Power Steering Oil Pressure Sensor Connector**  
Courtesy of HYUNDAI MOTOR CO.

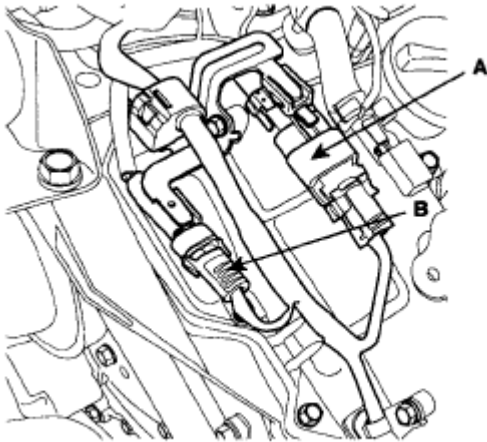
3. Disconnect RH injector connector (A) and ignition coil connector (B).



KDRF153A

**Fig. 16: Identifying RH Injector Connector And Ignition Coil Connector**  
Courtesy of HYUNDAI MOTOR CO.

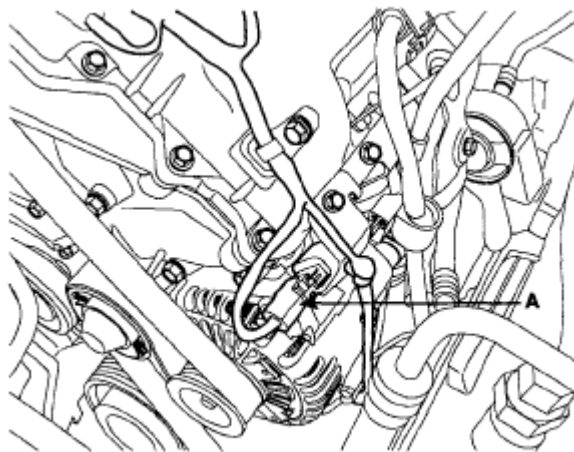
4. Disconnect OCV connector (A) and knock sensor connector (B).



KDRF155A

**Fig. 17: Identifying OCV Connector And Knock Sensor Connector**  
Courtesy of HYUNDAI MOTOR CO.

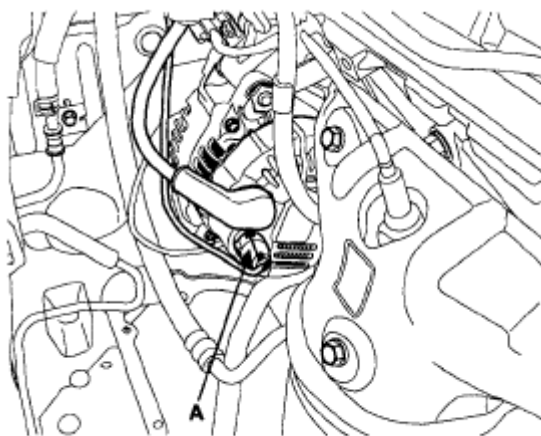
5. Disconnect LH front oxygen sensor connector (A).



KDRF156A

**Fig. 18: Identifying LH Front Oxygen Sensor Connector**  
Courtesy of HYUNDAI MOTOR CO.

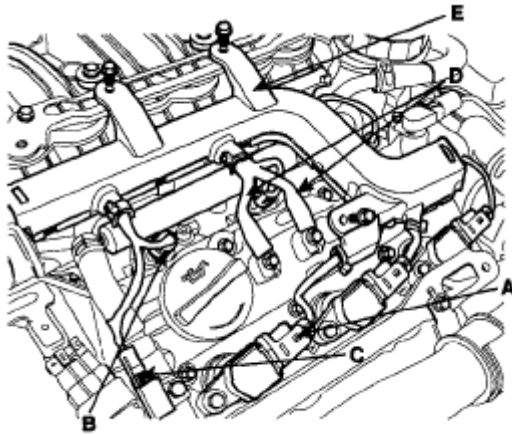
6. Disconnect alternator connector (A).



KDRF157A

**Fig. 19: Identifying Alternator Connector**  
Courtesy of HYUNDAI MOTOR CO.

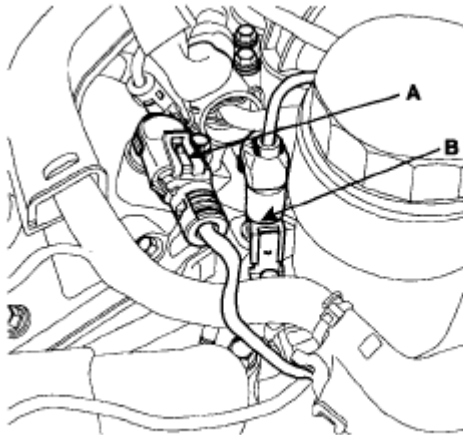
7. Disconnect LH ignition coil connector (A), injector connector (B), condenser connector (C) and ground (D), and remove wiring harness protector (E).



KDRF158A

**Fig. 20: Identifying LH Ignition Coil Connector, Injector Connector And Condenser Connector**  
Courtesy of HYUNDAI MOTOR CO.

8. Disconnect LH CMPS (A) and oil pressure switch connector (B).



KDRF159A

**Fig. 21: Identifying LH CMPS And Oil Pressure Switch Connector**  
Courtesy of HYUNDAI MOTOR CO.

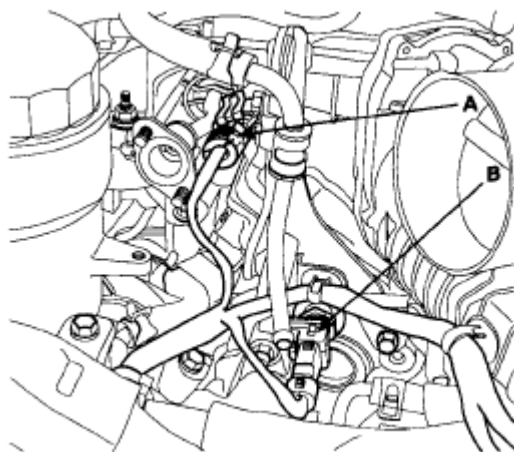
9. Disconnect PCSV connector (A) and MAP sensor connector (B).



KDRF160A

**Fig. 22: Identifying PCSV Connector And MAP Sensor Connector**  
Courtesy of HYUNDAI MOTOR CO.

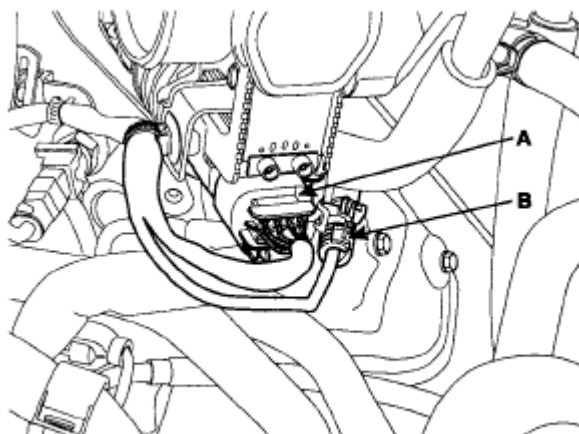
10. Disconnect RH CMPS (A) and OTS connector (B).



KDRF161A

**Fig. 23: Identifying RH CMPS And OTS Connector**  
Courtesy of HYUNDAI MOTOR CO.

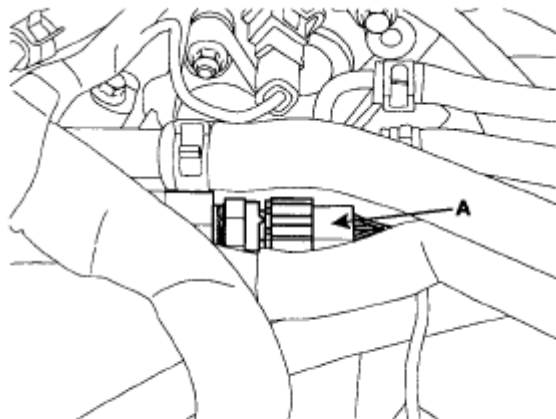
11. Disconnect ETC connector (A) and knock sensor connector (B).



KDRF162A

**Fig. 24: Identifying ETC Connector And Knock Sensor Connector**  
Courtesy of HYUNDAI MOTOR CO.

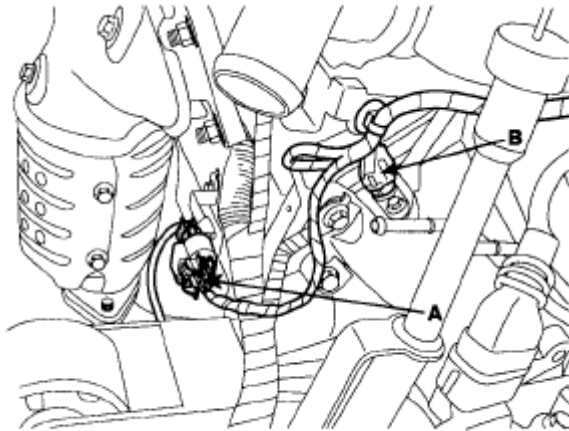
12. Disconnect WTS connector (A).



KDRF163A

**Fig. 25: Identifying WTS Connector**  
Courtesy of HYUNDAI MOTOR CO.

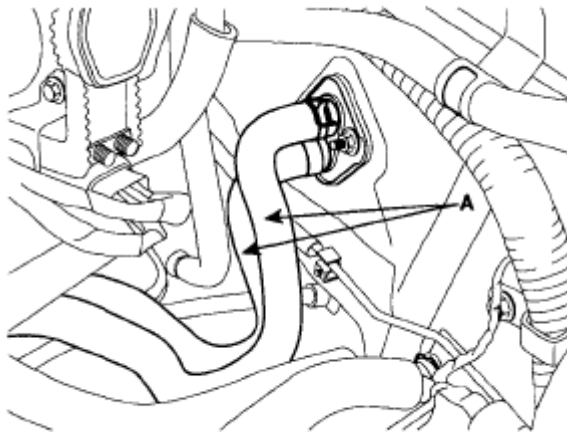
13. Disconnect LH rear oxygen sensor connector (A) and CPS connector (B).



KDRF184A

**Fig. 26: Identifying LH Rear Oxygen Sensor Connector And CPS Connector**  
Courtesy of HYUNDAI MOTOR CO.

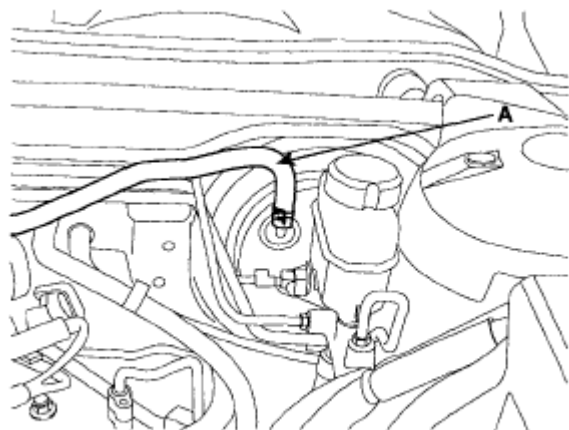
12. Disconnect the transaxle wire harness connector and remove the transaxle control cable. (See, **AUTOMATIC TRANSAXLE (A5HF1)** or **AUTOMATIC TRANSAXLE (F4A42)** ).
13. Disconnect EPS connector.
14. Remove heater hose (A).



KDRF185A

**Fig. 27: Identifying Heater Hose**  
Courtesy of HYUNDAI MOTOR CO.

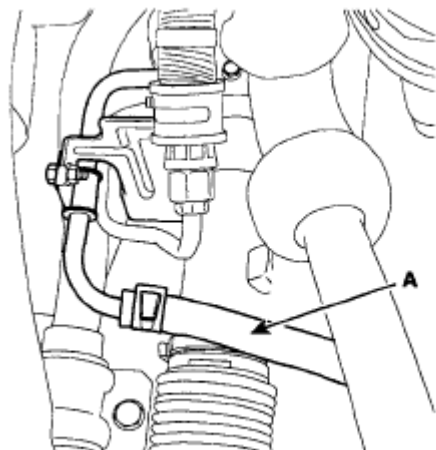
15. Remove brake vacuum hose (A).



KDRF166A

**Fig. 28: Identifying Brake Vacuum Hose**  
 Courtesy of HYUNDAI MOTOR CO.

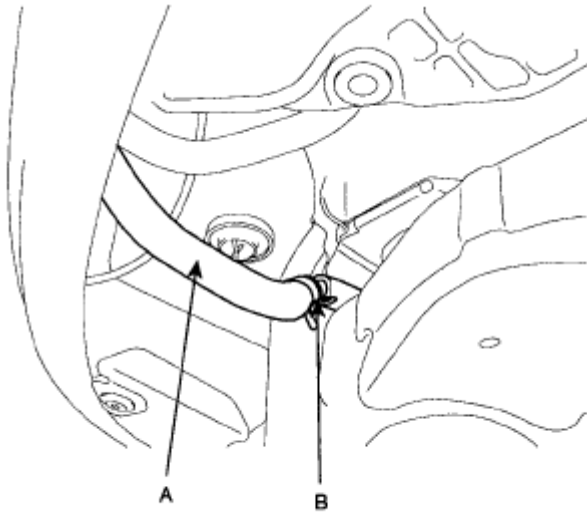
16. Remove power steering pump hose (A).



KDRF175A

**Fig. 29: Identifying Power Steering Pump Hose**  
 Courtesy of HYUNDAI MOTOR CO.

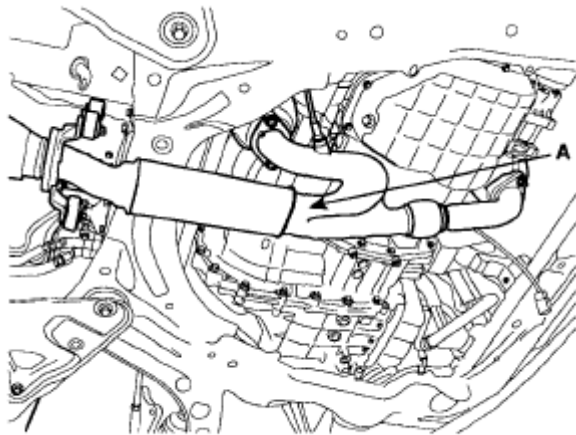
17. Remove A/C compressor hose.
18. Drain transaxle oil.
19. Remove lower arm ball joint. (See **FRONT AXLE** )
20. Remove tile rod end ball joint. (See **FRONT AXLE** )
21. Remove stabilizer link. (See **FRONT STABILIZER BAR** )
22. After removing a split pin and nut from the steering bar tie rod, disconnect it. (See **STEERING COLUMN AND SHAFT** )
23. Remove power steering return hose (A) and drain power steering oil.



KMRE009J

**Fig. 30: Identifying Power Steering Return Hose**  
 Courtesy of HYUNDAI MOTOR CO.

24. Remove front roll stopper mounting bolt.
25. Remove rear roll stopper mounting bolt.
26. Remove steering u-joint mounting (See **STEERING COLUMN AND SHAFT** )
27. Remove front exhaust pipe (A).



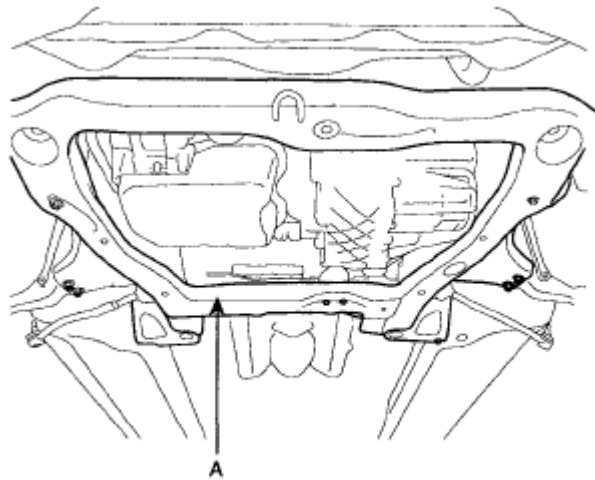
KDRF170A

**Fig. 31: Identifying Front Exhaust Pipe**  
 Courtesy of HYUNDAI MOTOR CO.

28. Supporting the cross member (A) with a jack, remove the stay with the mounting bolts.

Tightening torque:

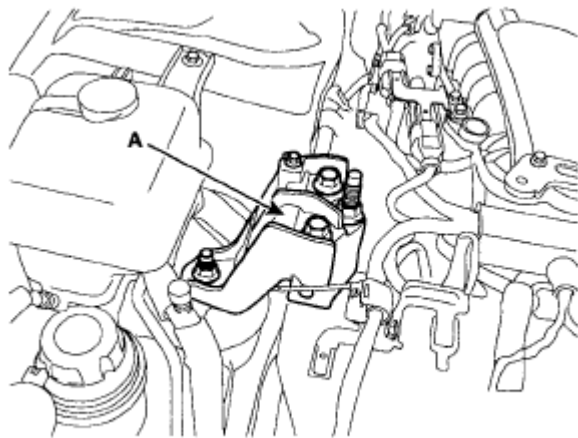
137.3~156.9 Nm (14.0~16.0 kgf.m, 101.3~115.7 lb~ft)



KMRE009R

**Fig. 32: Identifying Cross Member**  
Courtesy of HYUNDAI MOTOR CO.

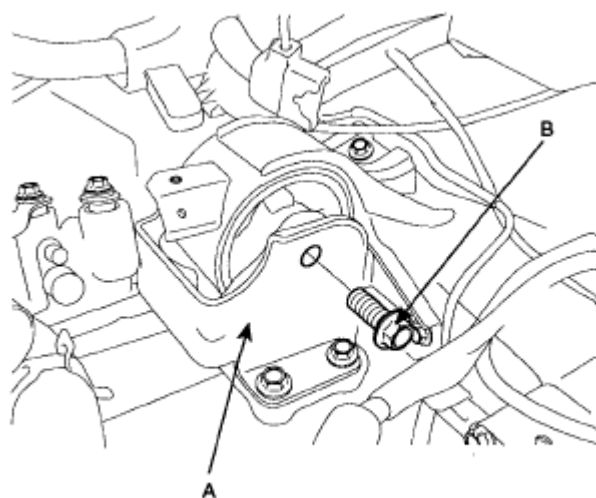
29. Remove drive shaft from transaxle. (See **DRIVESHAFT** )
30. Install jack for supporting engine and transaxle assembly.
31. Remove the engine mounting bracket (A).



KDRF172A

**Fig. 33: Identifying Engine Mounting Bracket**  
Courtesy of HYUNDAI MOTOR CO.

32. Remove the transaxle mounting bracket (A).



KMRE009T

**Fig. 34: Identifying Transaxle Mounting Bracket With Screw**  
 Courtesy of HYUNDAI MOTOR CO.

33. Jack up the vehicle.

## INSTALLATION

Installation is in the reverse order of removal.

Perform the following:

- Adjust the shift cable.
- Refill the engine with engine oil.
- Refill the transaxle with fluid.
- Refill the radiator with engine coolant.
- Bleed air from the cooling system with the heater valve open.
- Clean the battery posts and cable terminals with sandpaper assemble them, then apply grease to prevent corrosion.
- Inspect for fuel leakage.

After assembling the fuel line, turn on the ignition switch (do not operate the starter) so that the fuel pump runs for approximately two seconds and fuel line pressurizes.

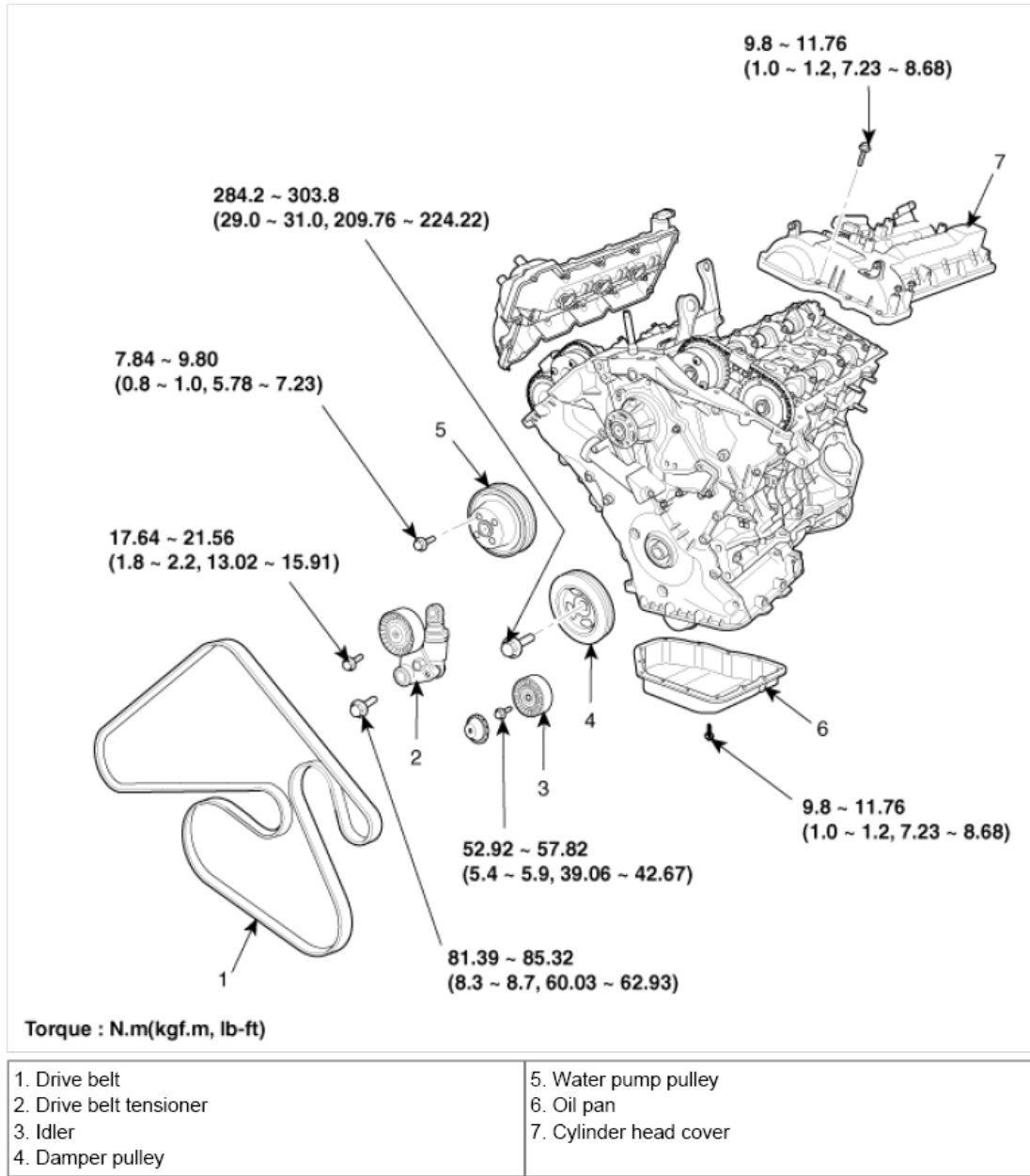
Repeat this operation two or three times, then check for fuel leakage at any point in the fuel line.

## TIMING SYSTEM

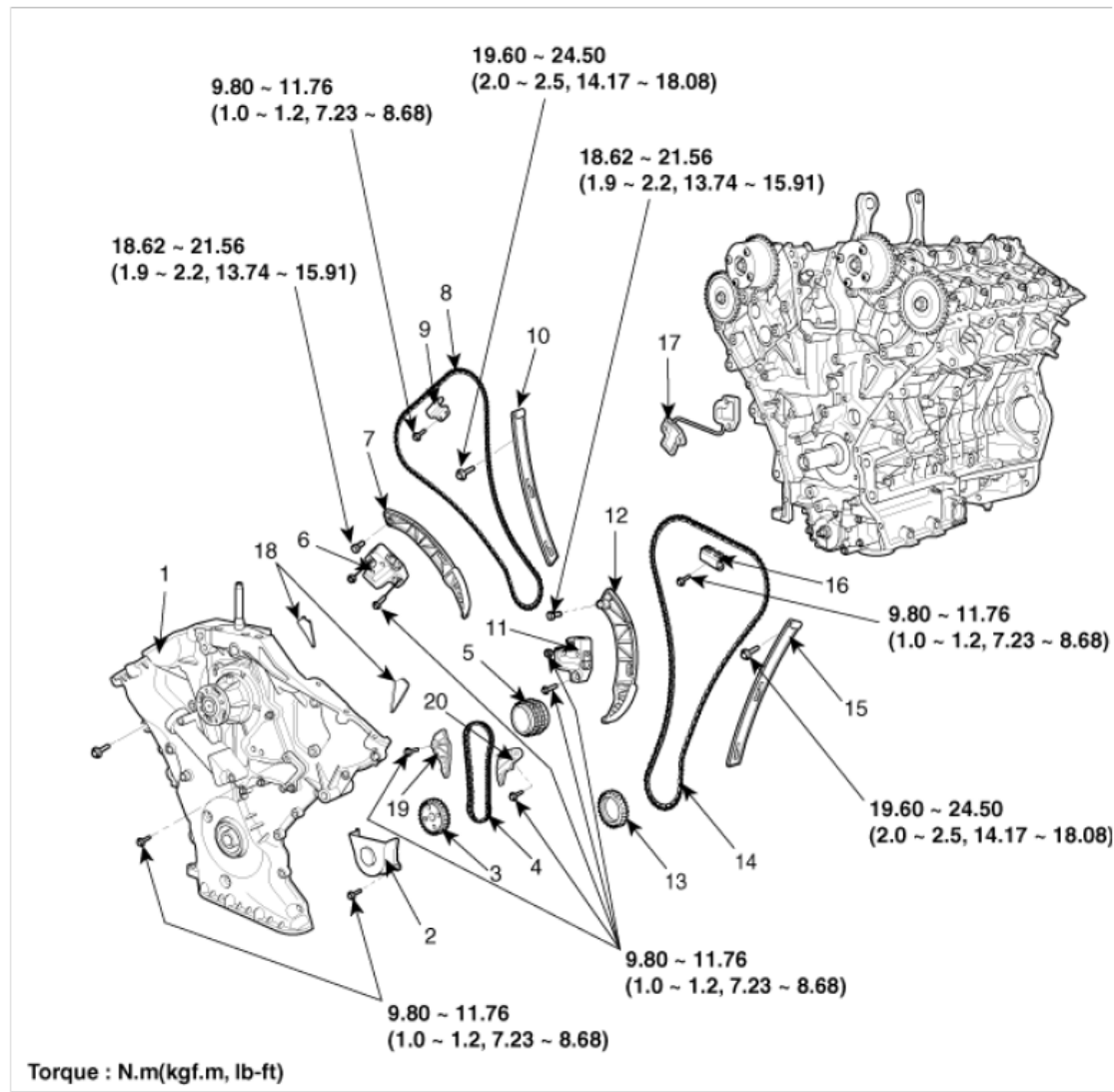
### TIMING CHAIN

Components and Components Location

Components



**Fig. 35: Exploded View Of Timing Chain System With Torque Specification (1 Of 2)**



1. Timing chain cover	8. Timing chain	15. Timing chain guide
2. Oil pump chain cover	9. Cam to cam guide	16. Cam to cam guide
3. Oil pump sprocket	10. Timing chain guide	17. Tensioner adapter
4. Oil pump chain	11. Timing chain auto tensioner	18. Gasket
5. Crankshaft sprocket	12. Timing chain tensioner arm	19. Oil pump chain guide
6. Timing chain auto tensioner	13. Crankshaft sprocket	20. Oil pump tensioner assembly
7. Timing chain tensioner arm	14. Timing chain	

**Fig. 36: Exploded View Of Timing Chain System With Torque Specification (2 Of 2)**

**Repair procedures**

**Removal**

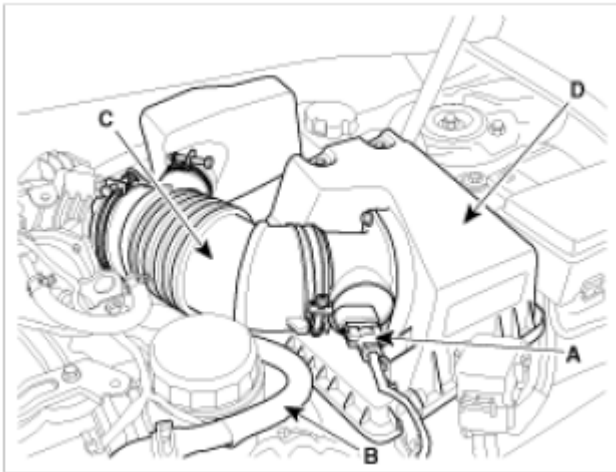
**CAUTION:**

- Use fender covers to avoid damaging painted surfaces.
- To avoid damage, unplug the wiring connectors carefully while holding the connector portion.

**NOTE:**

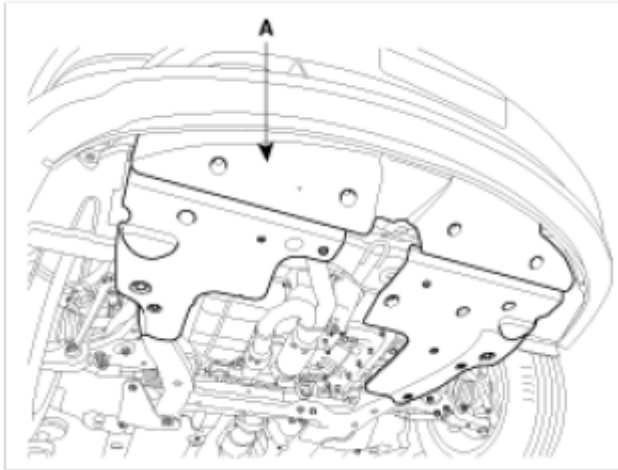
- **Mark all wiring and hoses to avoid misconnection.**
- **Turn the crankshaft pulley so that the No. 1 piston is at top dead center.**

1. Disconnect the negative terminal from the battery.
2. Remove the engine cover.
3. Remove the air duct.
4. Remove the intake air hose and air cleaner assembly.
  1. Disconnect the AFS connector (A).
  2. Disconnect the breather hose (B) from air cleaner hose.
  3. Disconnect the ECM connector.
  4. Remove the intake air hose (C) and air cleaner (D).



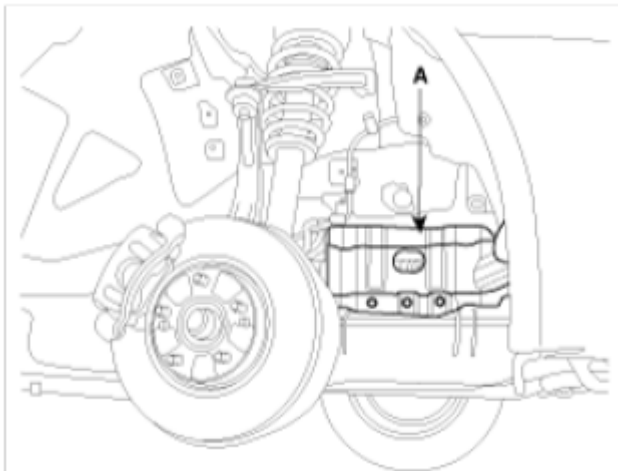
**Fig. 37: Identifying AFS Connector, Breather Hose, Intake Air Hose And Air Cleaner**

5. Remove the front wheels.
6. Remove the under cover (A).



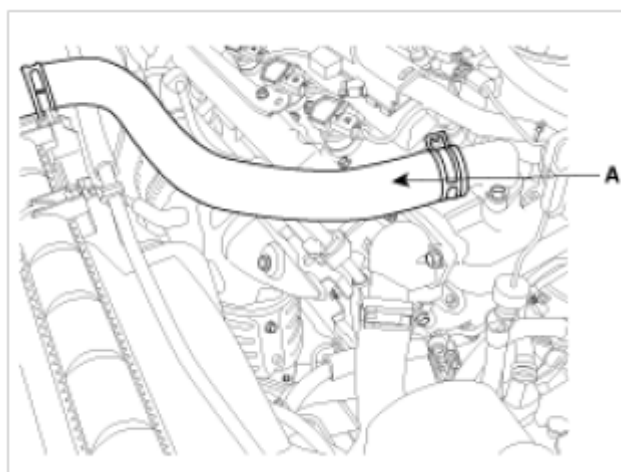
**Fig. 38: Identifying Under Cover**

7. Remove the side cover (A).



**Fig. 39: Identifying Side Cover**

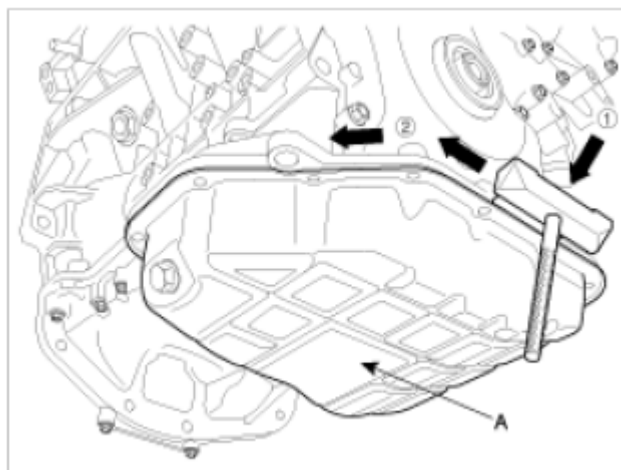
8. Drain the engine coolant.  
Remove the radiator cap to speed draining.
9. Remove the upper radiator hose (A).



**Fig. 40: Identifying Upper Radiator Hose**

10. Drain the engine oil.
11. Remove the lower oil pan (A).

Insert the blade of SST (09215-3C000) between the upper oil pan and lower oil pan, and cut off applied sealer and removed lower oil pan.



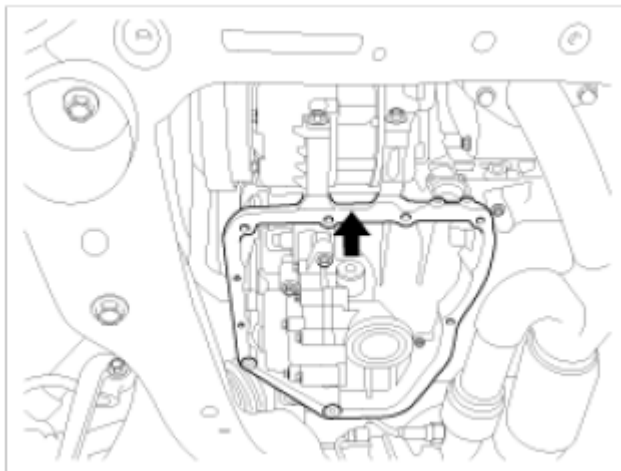
**Fig. 41: Inserting Blade Of SST (09215-3C000) Between Upper Oil Pan And Lower Oil Pan**

**NOTE:**

- Insert the SST between the oil pan and the ladder frame by tapping it with a plastic hammer in the direction of arrow.
- After tapping the SST with a plastic hammer along the direction of arrow around more than 2/3 edge of the oil pan, remove it from the ladder frame.
- Do not turn over the SST abruptly without tapping. It be result in damage of the SST.

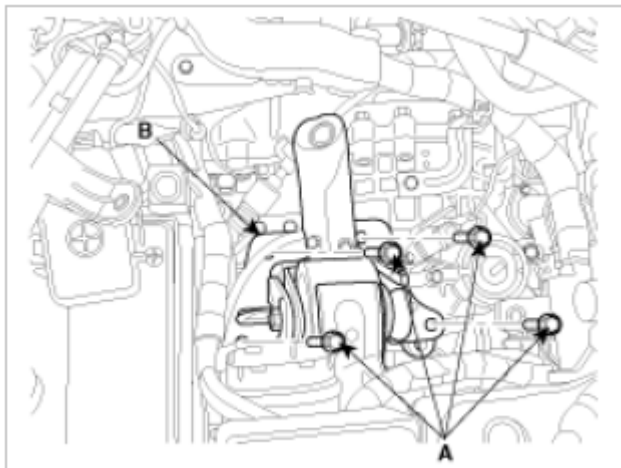
- Be careful not to damage the contact surfaces of Upper oil pan and lower oil pan.

12. Install the jack to the upper oil pan.



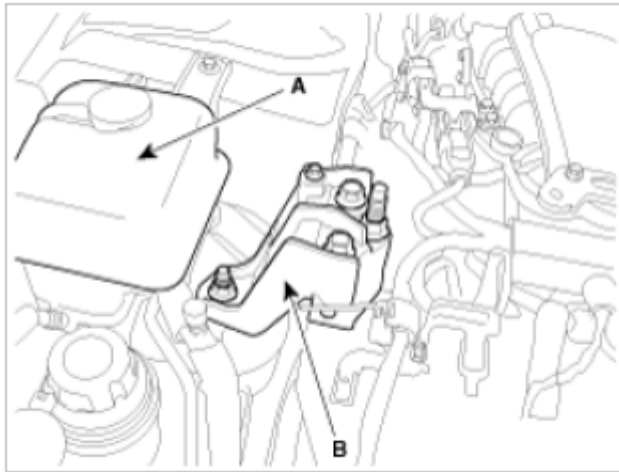
**Fig. 42: Locating Upper Oil Pan**

13. Just loosen the transaxle mounting bolts (A) without removing the transaxle mounting (B).



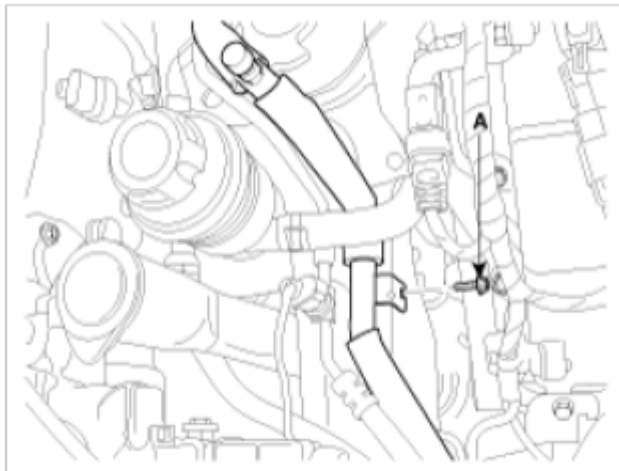
**Fig. 43: Identifying Transaxle Mounting And Mounting Bolts**

14. Remove the engine coolant reservoir tank (A).
15. Remove the engine mounting bracket (B).



**Fig. 44: Identifying Engine Coolant Reservoir Tank And Engine Mounting Bracket**

16. Loosen the A/C pipe bracket mounting bolt (A).



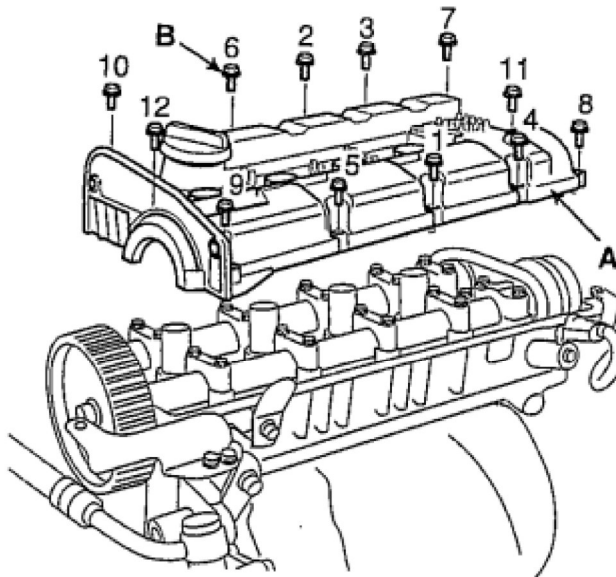
**Fig. 45: Identifying A/C Pipe Bracket Mounting Bolt**

17. Remove the no.1 engine mounting (A) through the lower position of A/C pipe line.



**Fig. 46: Identifying No.1 Engine Mounting**

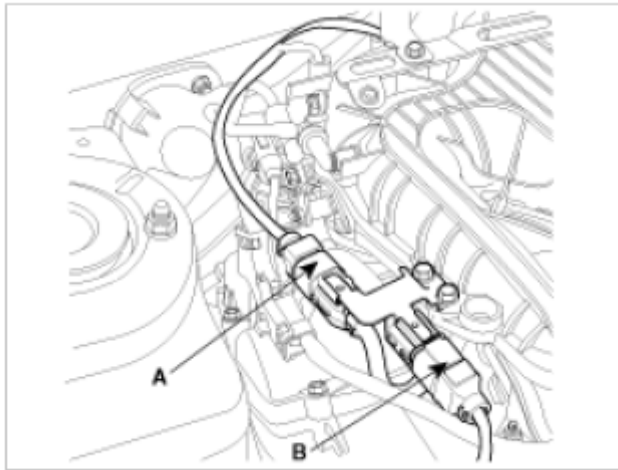
18. Remove the surge tank.
  1. Disconnect the RH oxygen sensor connector (A).



ADIE003A

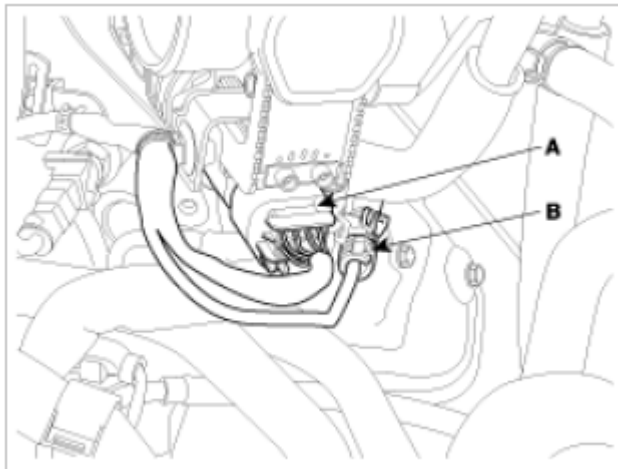
**Fig. 47: Identifying RH Oxygen Sensor Connector**

2. Disconnect the RH injector connector (A) and the ignition coil connector (B).



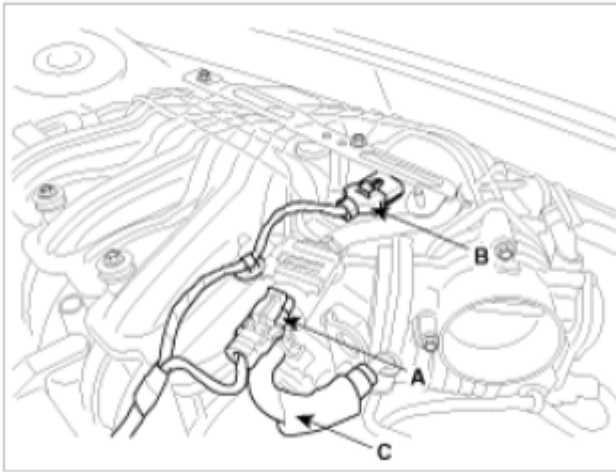
**Fig. 48: Identifying RH Injector Connector And Ignition Coil Connector**

3. Disconnect the ETC connector (A) and the knock sensor connector (B).



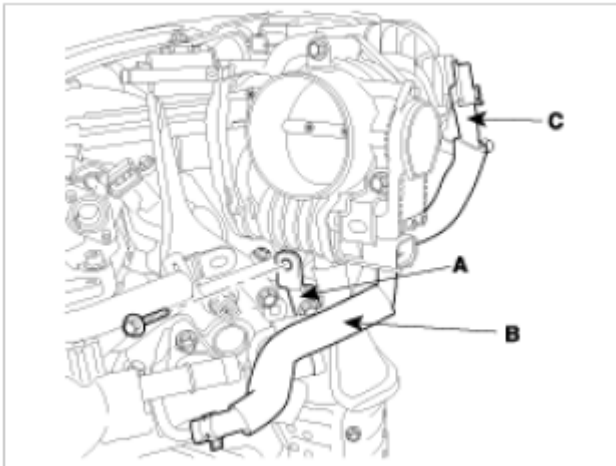
**Fig. 49: Identifying ETC Connector And Knock Sensor Connector**

4. Disconnect the PCSV connector (A), the MAP sensor connector (B) and the PCSV hose (C).



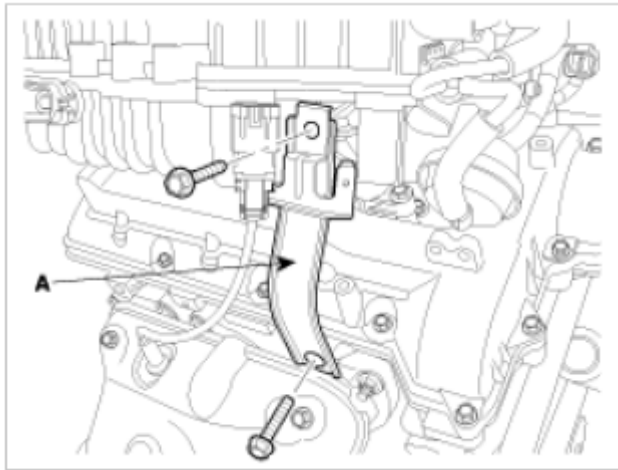
**Fig. 50: Identifying PCSV Connector, Map Sensor Connector And PCSV Hose**

5. Remove the ETC bracket (A).
6. Disconnect the water hoses (B) from the ETC.
7. Disconnect the PCV (C) hose.



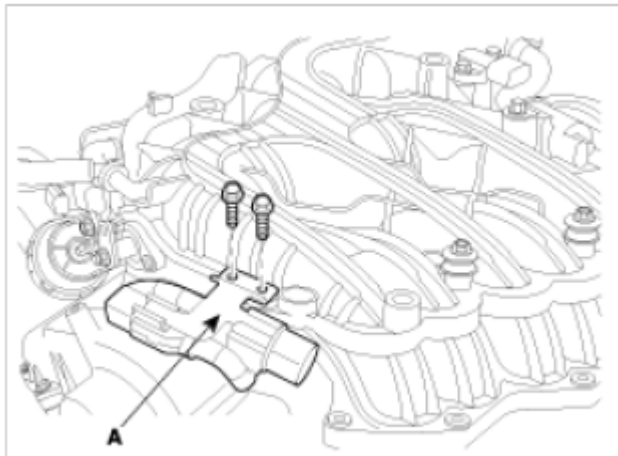
**Fig. 51: Identifying ETC Bracket, Water Hoses And PCV Hose**

8. Disconnect the brake vacuum hose.
9. Remove the surge tank stay (A).



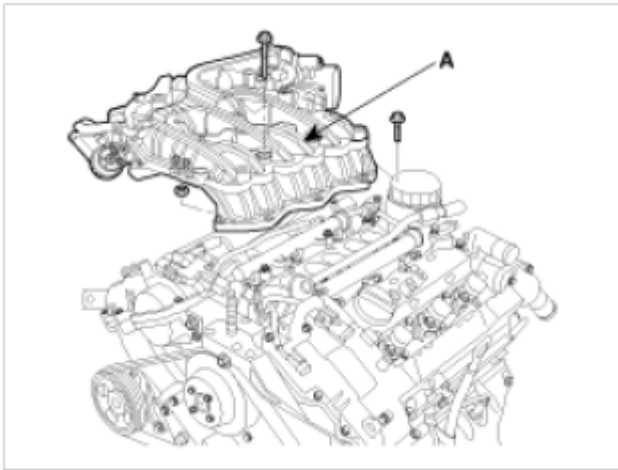
**Fig. 52: Identifying Surge Tank Stay With Mounting Bolts**

10. Remove the connector bracket (A) from the surge tank.



**Fig. 53: Identifying Surge Tank Connector Bracket With Mounting Bolts**

11. Remove the surge tank (A).



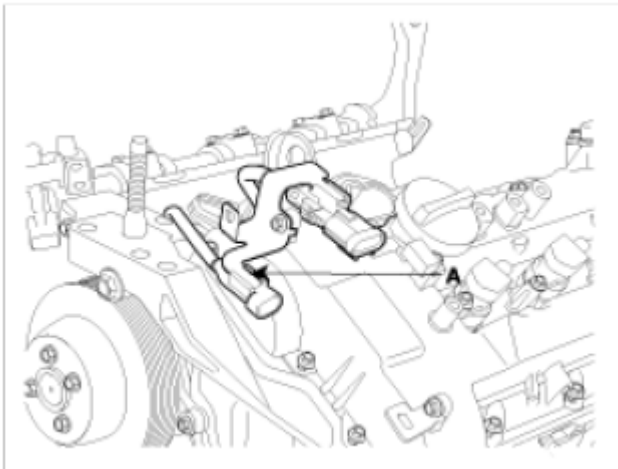
**Fig. 54: Identifying Surge Tank With Mounting Bolts**

**NOTE:**

- Cover the inlet of intake manifold with a clean woven stuff or vinyl cover to prevent foreign materials from entering.

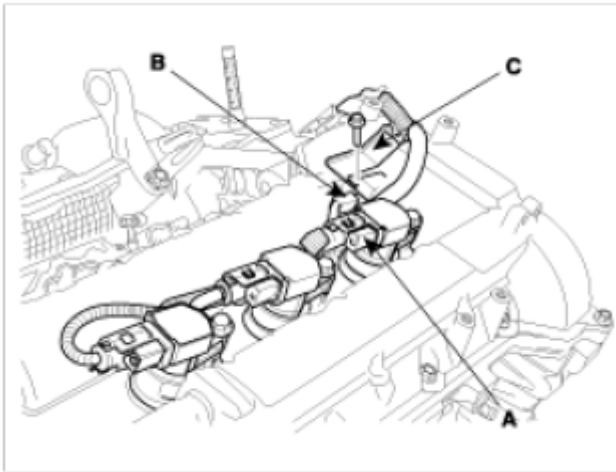
19. Remove the cylinder head cover.

1. Remove the connector bracket (A) from the LH cylinder head cover.



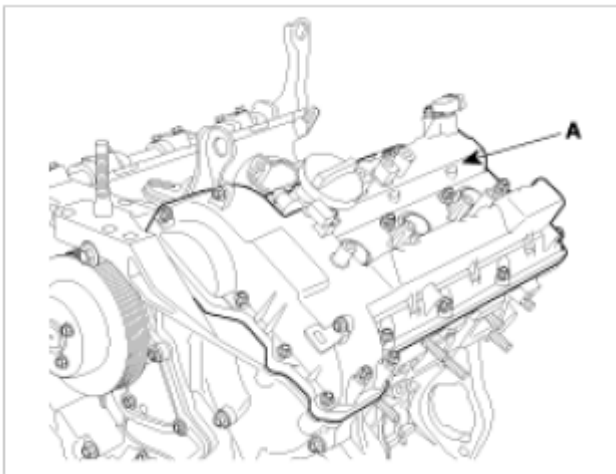
**Fig. 55: Identifying LH Cylinder Head Cover Connector Bracket**

2. Disconnect the RH ignition coil connector (A), the condenser connector (B) and remove the wiring bracket (C).



**Fig. 56: Identifying RH Ignition Coil Connector, Condenser Connector And Wiring Bracket**

3. Remove the LH, RH ignition coil.
4. Remove the LH, RH cylinder head cover (A).



**Fig. 57: Identifying LH And RH Cylinder Head Cover**

**NOTE:**

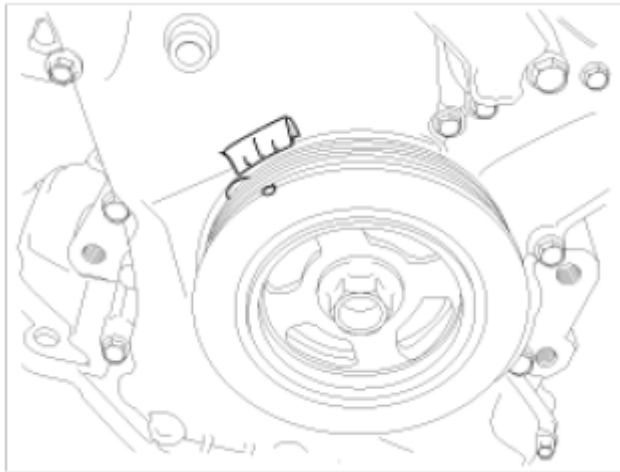
- Cover the upside of engine head with a clean woven stuff or vinyl cover to prevent foreign materials from entering.

20. Set No. 1 cylinder to TDC/compression.

1. Turn the crankshaft pulley and align its groove with the timing mark "T" of the lower timing chain cover.

**NOTE:**

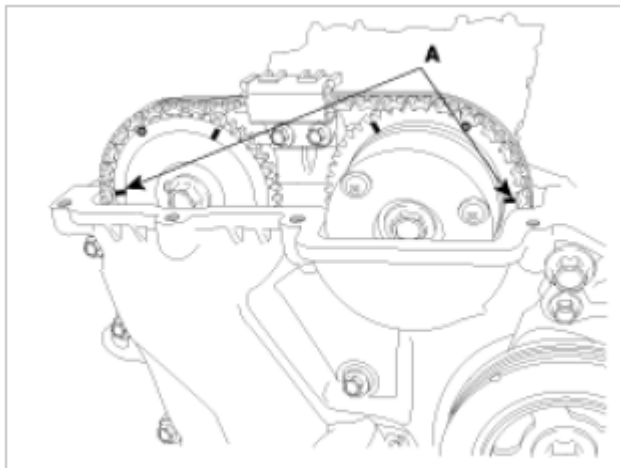
**Do not rotate engine counterclockwise.**



**Fig. 58: Identifying Timing Mark On Lower Timing Chain Cover**

2. Check that the mark (A) of the camshaft timing sprockets are in straight line on the cylinder head surface as shown in the illustration.

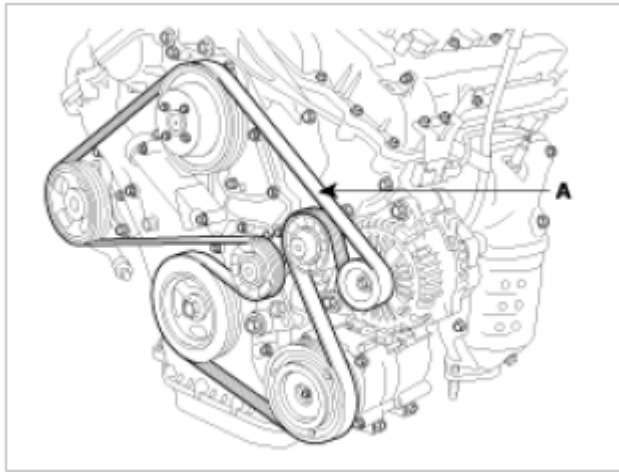
If not, turn the crankshaft one revolution (360°).



**Fig. 59: Identifying Mark On Camshaft Timing Sprockets**

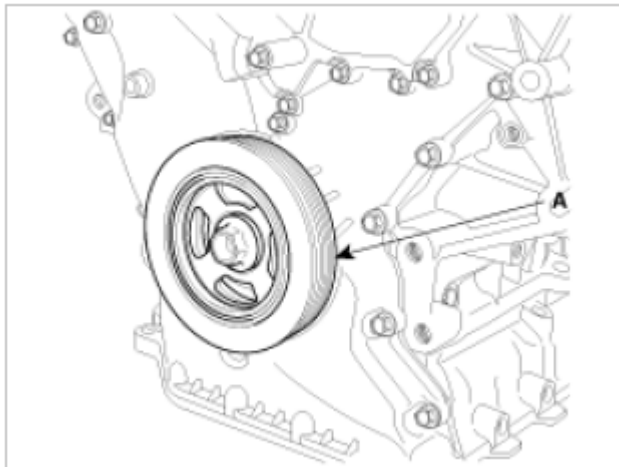
**NOTE:** Do not rotate engine counterclockwise.

21. Remove the drive belt (A).



**Fig. 60: Identifying Drive Belt**

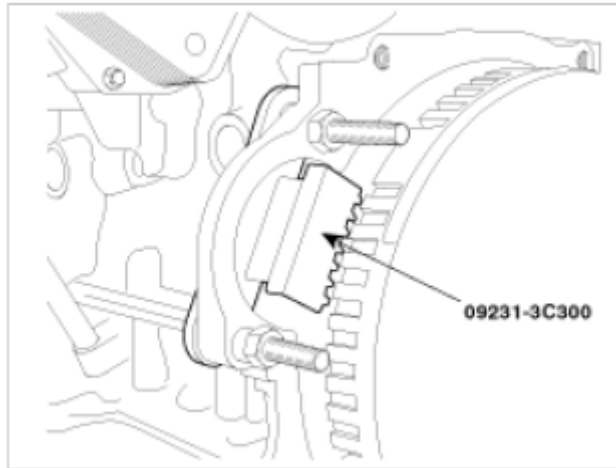
22. Remove the crankshaft damper pulley (A).



**Fig. 61: Identifying Crankshaft Damper Pulley**

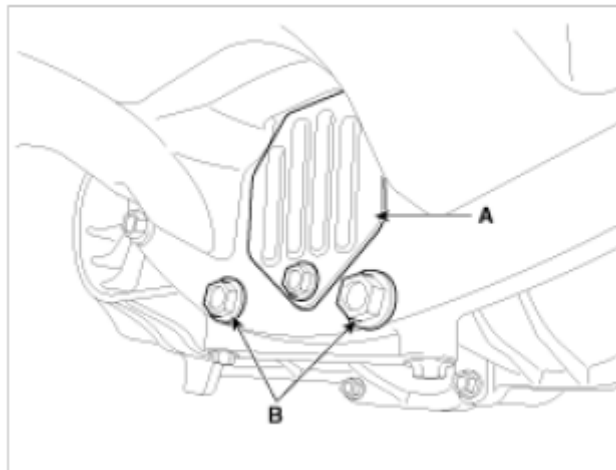
**NOTE:** There are two methods to hold the ring gear when installing or removing the crankshaft damper pulley.

- Install the SST (09231-3C300) to hold the ring gear after removing the starter.



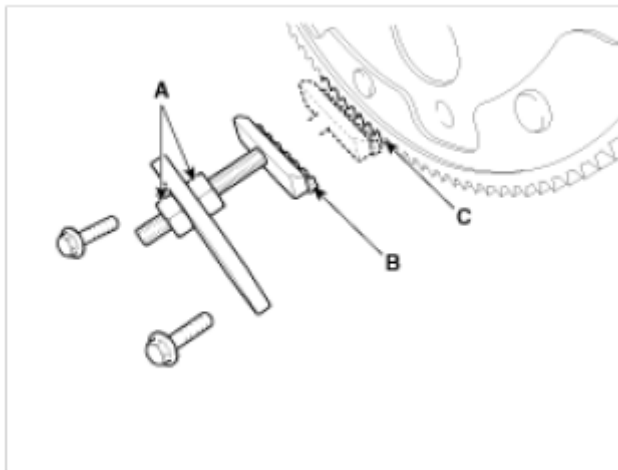
**Fig. 62: Installing Crankshaft Damper Pulley Using SST (09231-3C300)**

- Install the SST (09231-3D100) to hold the ring gear after removing the dust cover.
1. Remove the front muffler. (Refer to Intake And Exhaust system.)
  2. Remove the dust cover (A) on the bottom of the upper oil pan and unfasten the two transaxle mounting bolts (B).



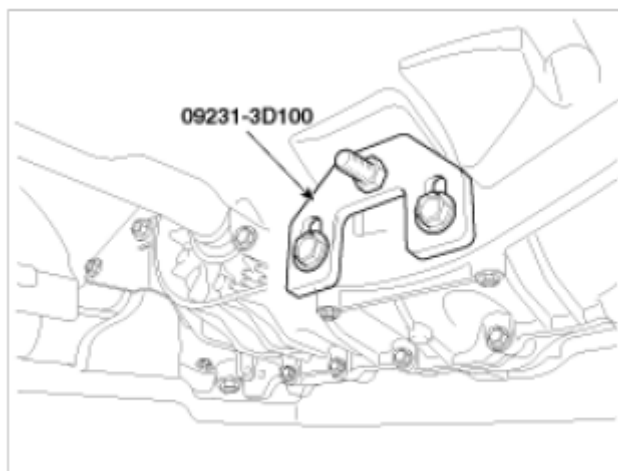
**Fig. 63: Identifying Dust Cover And Transaxle Mounting Bolts**

3. Adjust the length of the holder nuts (A) so that the front plate of the holder (B) puts in the ring gear (C) teeth.
4. Fasten the two transaxle mounting bolts in the original mounted holes.



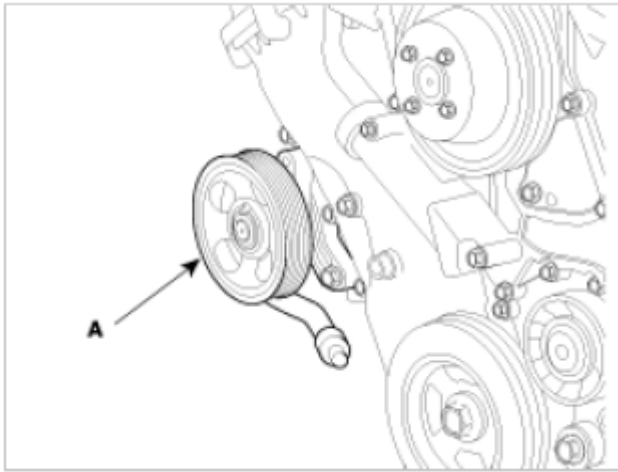
**Fig. 64: Identifying Holder Nuts, Holder And Ring Gear With Mounting Bolts**

5. Install the SST (09231-3D100) using the two mounting bolts. Tighten the bolts and nuts of the holder securely.



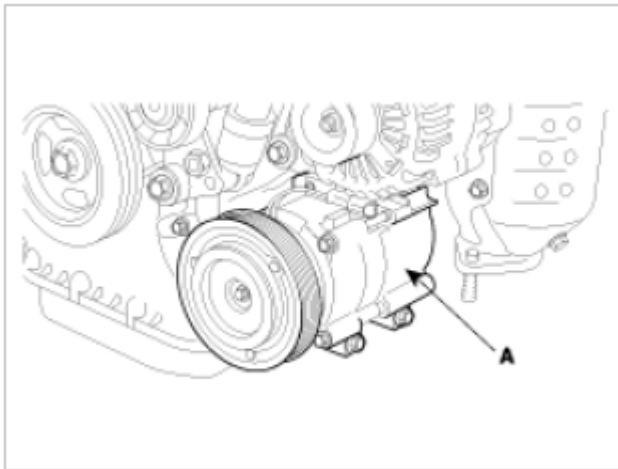
**Fig. 65: Installing SST (09231-3D100) Using Mounting Bolts**

23. Lift up the engine assembly by using the jack.
24. Remove the power steering pump (A).



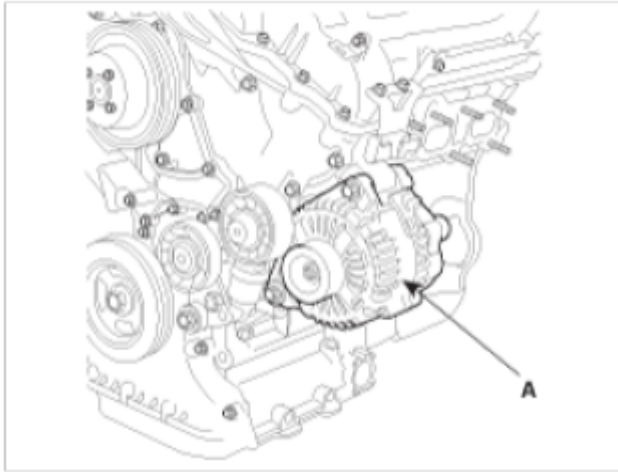
**Fig. 66: Identifying Power Steering Pump**

25. Remove the air conditioner compressor (A).



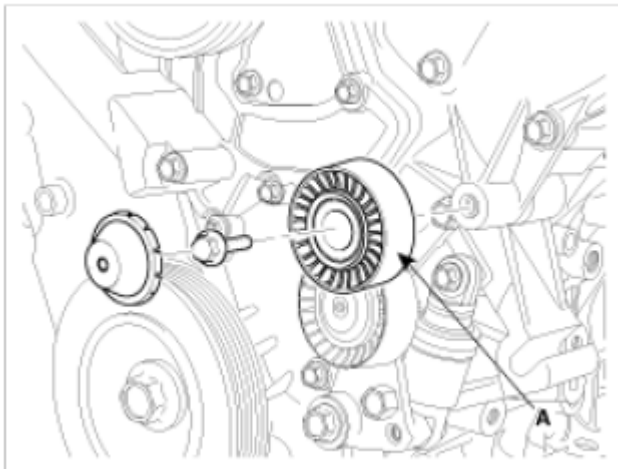
**Fig. 67: Identifying Air Conditioner Compressor**

26. Remove the alternator (A).



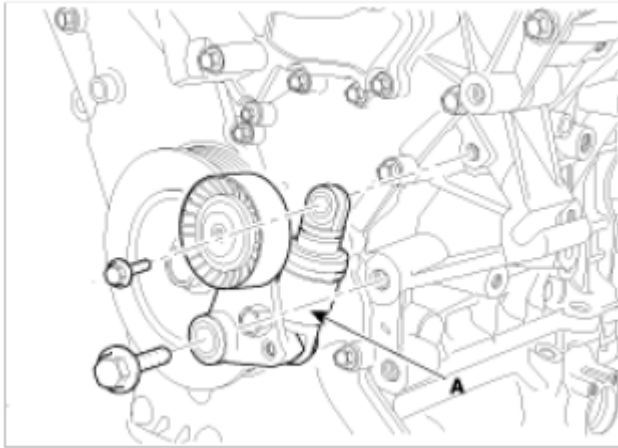
**Fig. 68: Identifying Alternator**

27. Remove the drive belt idler (A).



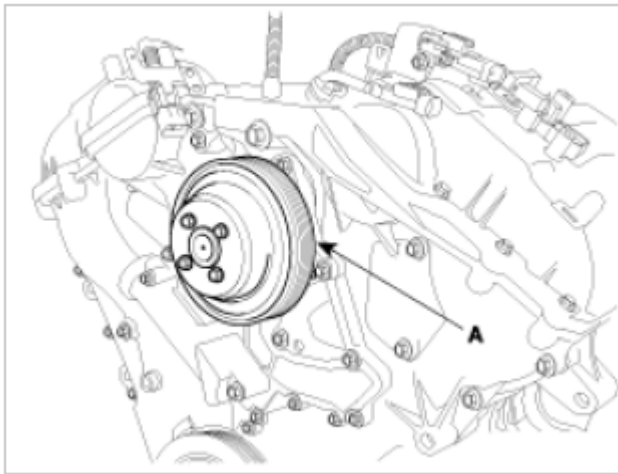
**Fig. 69: Identifying Drive Belt Idler With Mounting Bolt**

28. Remove the drive belt auto tensioner (A).



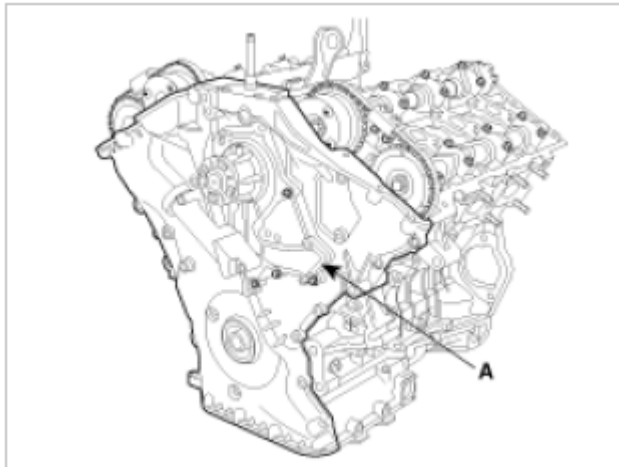
**Fig. 70: Identifying Drive Belt Auto Tensioner With Mounting Bolts**

29. Remove water pump pulley (A).



**Fig. 71: Identifying Water Pump Pulley**

30. Remove the timing chain cover (A).



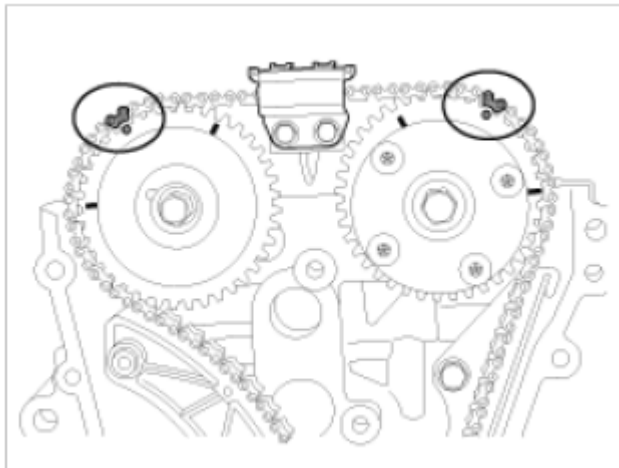
**Fig. 72: Identifying Timing Chain Cover**

**CAUTION:**

- Be careful not to damage the contact surfaces of cylinder block, cylinder head and timing chain cover.

**NOTE:**

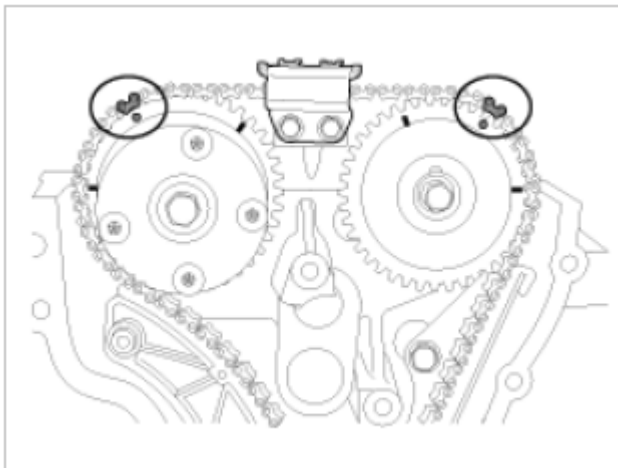
- Before removing the timing chain, mark the RH/LH timing chain with an identification based on the location of the sprocket because the identification mark on the chain for TDC (Top Dead Center) can be erased.



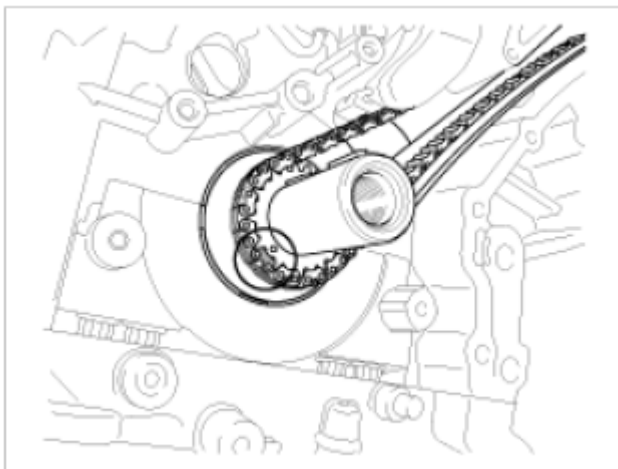
**Fig. 73: Identifying Timing Mark On Sprocket And Timing Chain (1 Of 3)**



**Fig. 74: Identifying Timing Mark On Sprocket And Timing Chain (2 Of 3)**



**Fig. 75: Identifying Timing Mark On Sprocket And Timing Chain (3 Of 3)**



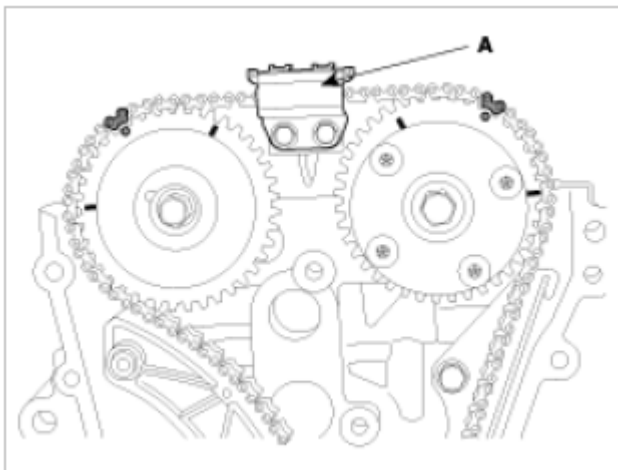
**Fig. 76: Identifying Timing Chain**

31. Install a set pin after compressing the RH timing chain tensioner.



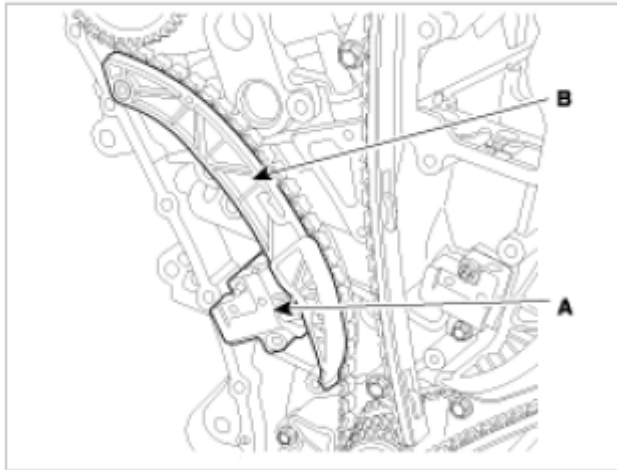
**Fig. 77: Installing Set Pin**

32. Remove the RH cam-to-cam guide (A).



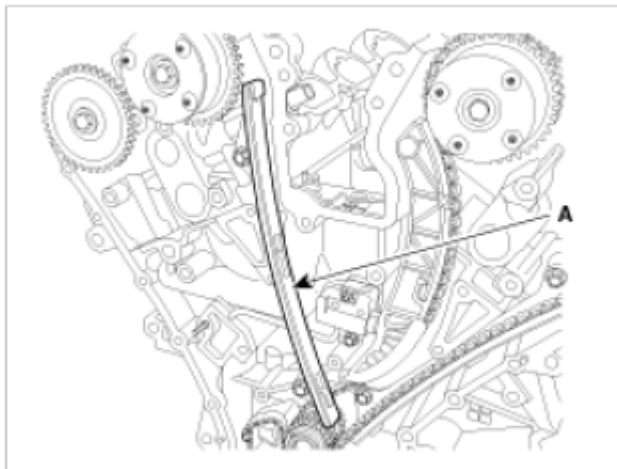
**Fig. 78: Identifying RH Cam-To-Cam Guide**

33. Remove the RH timing chain auto tensioner (A) and the RH timing chain tensioner arm (B).



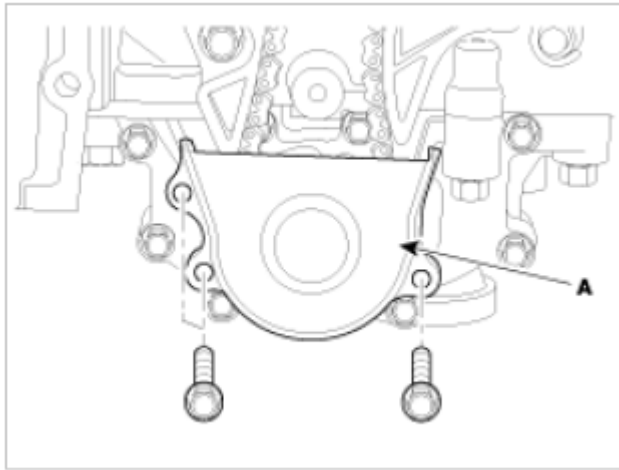
**Fig. 79: Identifying RH Timing Chain Auto Tensioner And RH Timing Chain Tensioner Arm**

- 34. Remove the RH timing chain.
- 35. Remove the RH timing chain guide (A).



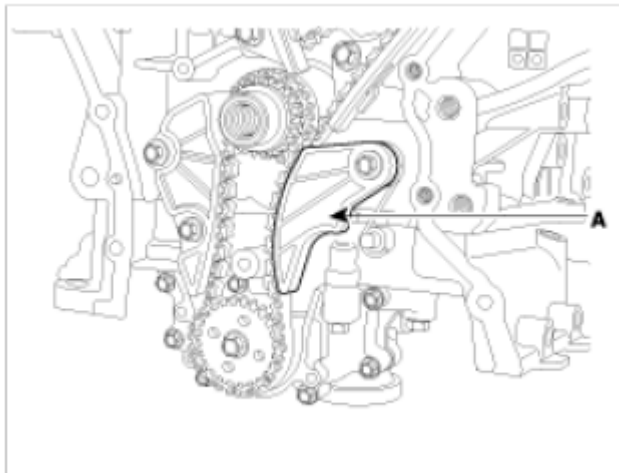
**Fig. 80: Identifying RH Timing Chain Guide**

- 36. Remove the oil pump chain cover (A).



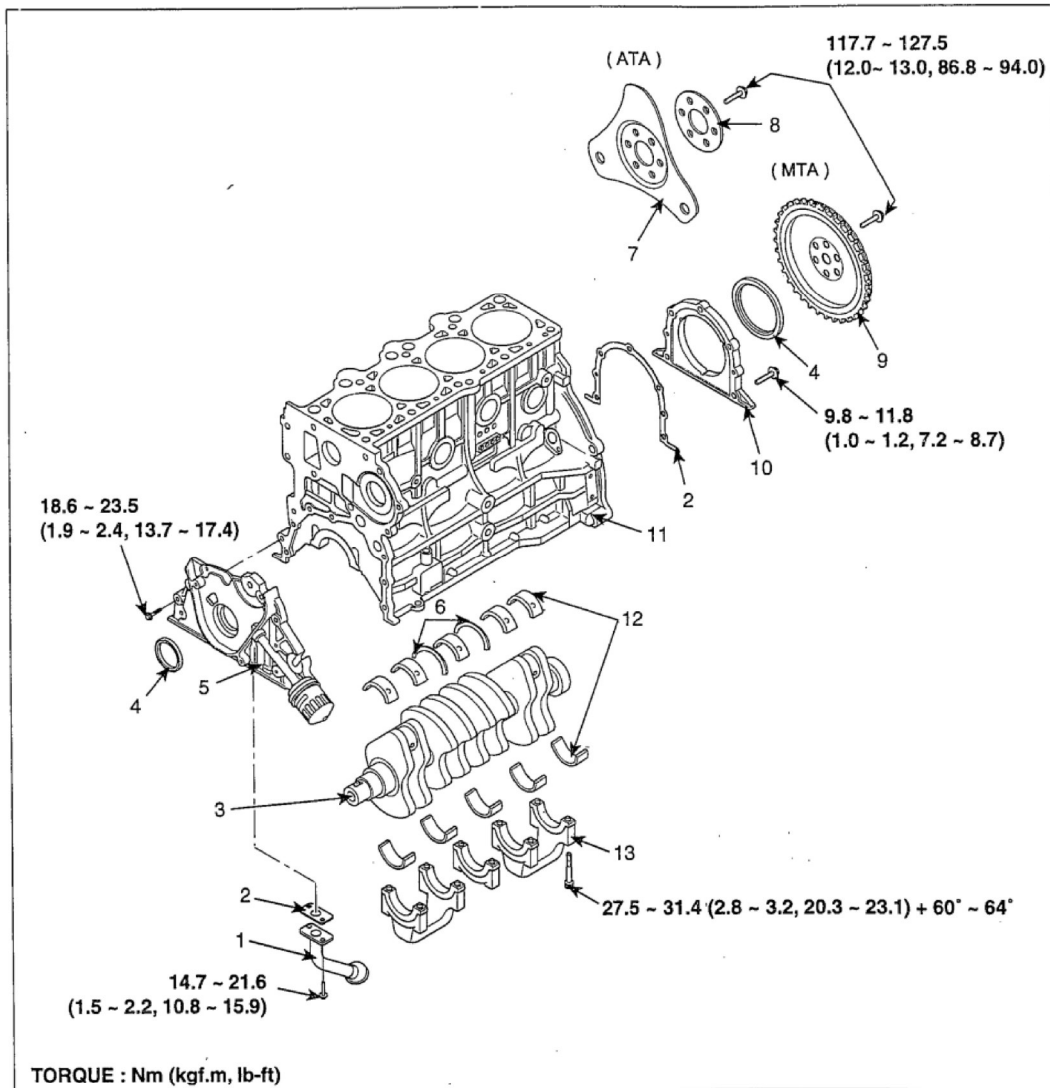
**Fig. 81: Identifying Oil Pump Chain Cover With Mounting Bolts**

37. Remove the oil pump chain tensioner assembly (A).



**Fig. 82: Identifying Oil Pump Chain Tensioner Assembly**

38. Remove the oil pump chain guide (A).

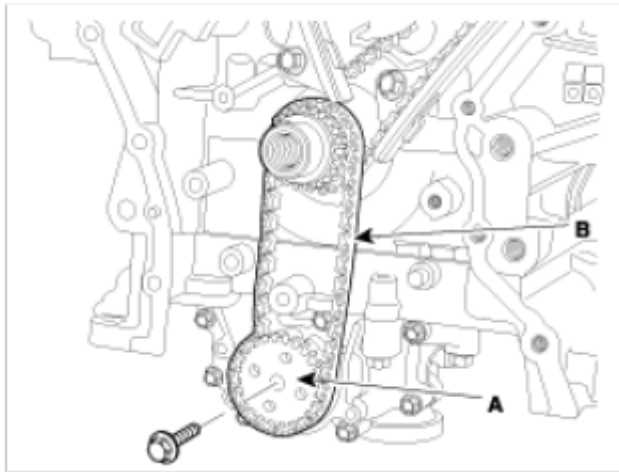


- |                   |                        |
|-------------------|------------------------|
| 1. Oil screen     | 8. Washer              |
| 2. Gasket         | 9. Adapter plate       |
| 3. Crankshaft     | 10. Rear oil seal case |
| 4. Oil seal       | 11. Cylinder block     |
| 5. Front case     | 12. Main bearing       |
| 6. Thrust bearing | 13. Main bearing cap   |
| 7. Drive plate    |                        |

SHDM16303L

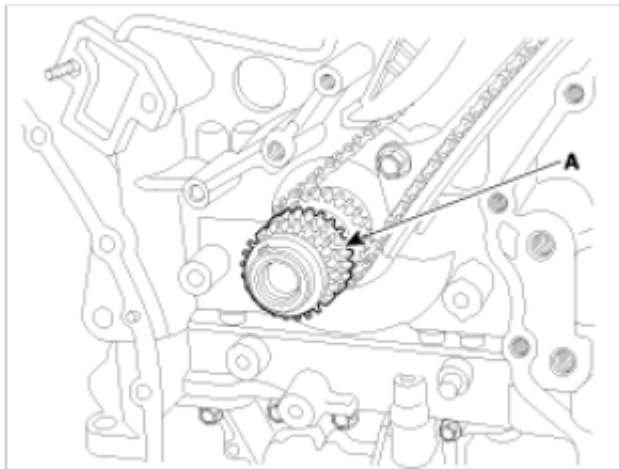
**Fig. 83: Identifying Oil Pump Chain Guide**

39. Remove the oil pump chain sprocket (A) and oil pump chain (B).



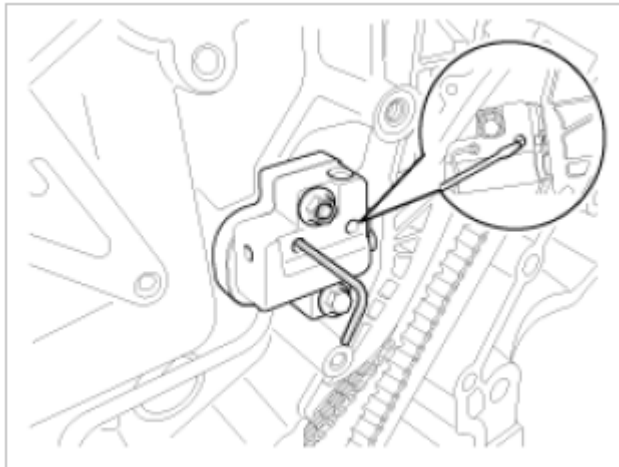
**Fig. 84: Identifying Oil Pump Chain Sprocket And Oil Pump Chain With Mounting Bolts**

40. Remove the crankshaft sprocket (A) (O/P & RH camshaft drive).



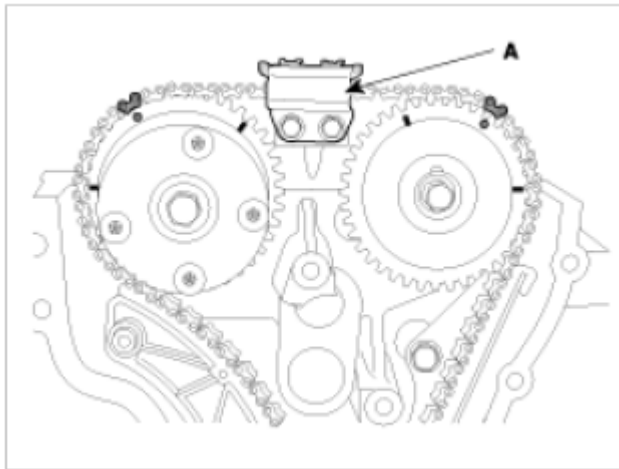
**Fig. 85: Identifying Crankshaft Sprocket (O/P & RH Camshaft Drive)**

41. Install a set pin after compressing the LH timing chain tensioner.



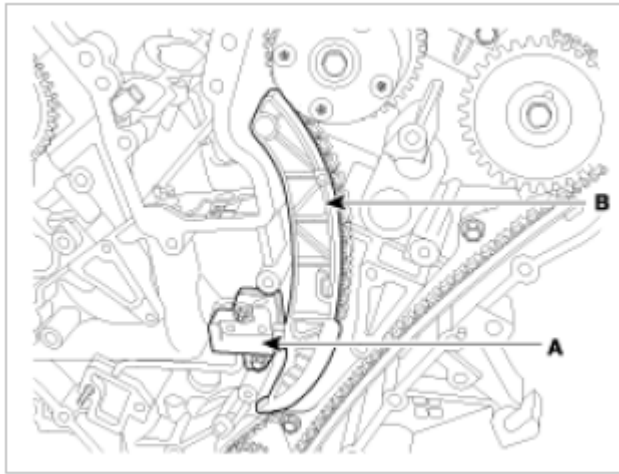
**Fig. 86: Installing Set Pin**

42. Remove the LH cam-to-cam guide (A).



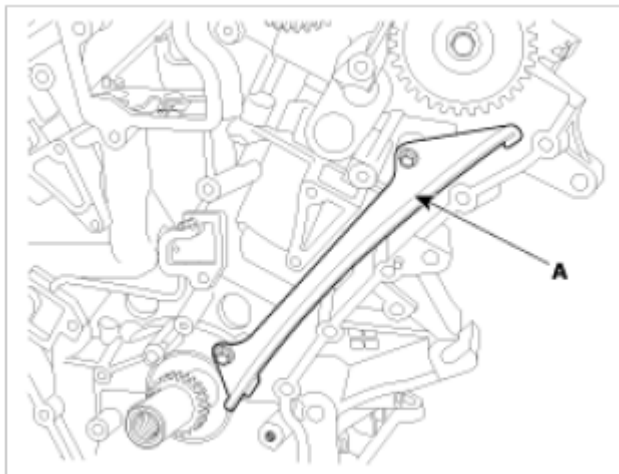
**Fig. 87: Identifying LH Cam-To-Cam Guide**

43. Remove the LH timing chain auto tensioner (A) and LH timing chain tensioner arm (B).



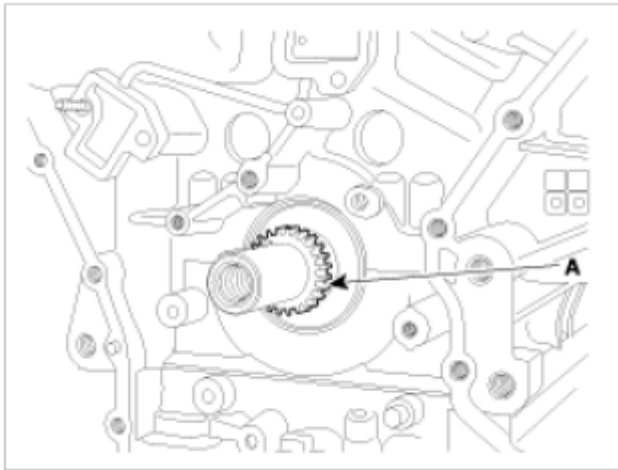
**Fig. 88: Identifying LH Timing Chain Auto Tensioner And LH Timing Chain Tensioner Arm**

- 44. Remove the LH timing chain.
- 45. Remove the LH timing chain guide (A).



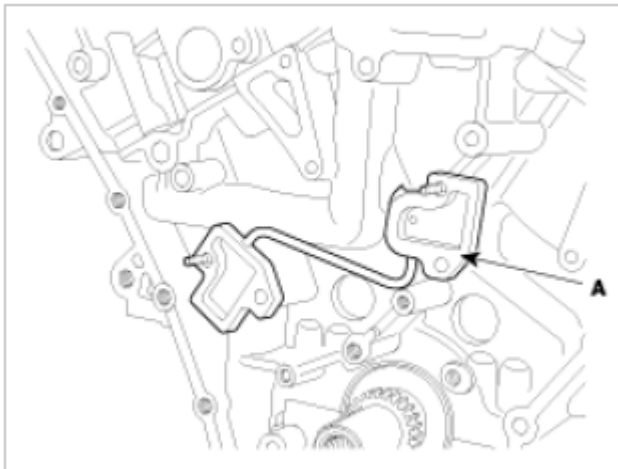
**Fig. 89: Identifying LH Timing Chain Guide**

- 46. Remove the crankshaft sprocket (A) (LH camshaft drive).



**Fig. 90: Identifying Crankshaft Sprocket (LH Camshaft Drive)**

47. Remove the tensioner adapter assembly (A).



**Fig. 91: Identifying Tensioner Adapter Assembly**

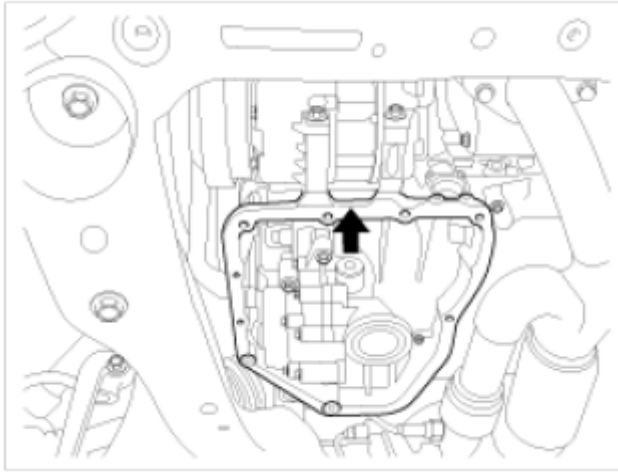
### Inspection

#### Sprockets, Chain Tensioner, Chain Guide, Chain Tensioner Arm

1. Check the camshaft sprocket and crankshaft sprocket for abnormal wear, cracks, or damage. Replace as necessary.
2. Inspect the tensioner arm and chain guide for abnormal wear, cracks, or damage. Replace as necessary.
3. Check that the tensioner piston moves smoothly when the ratchet pawl is released with thin rod.

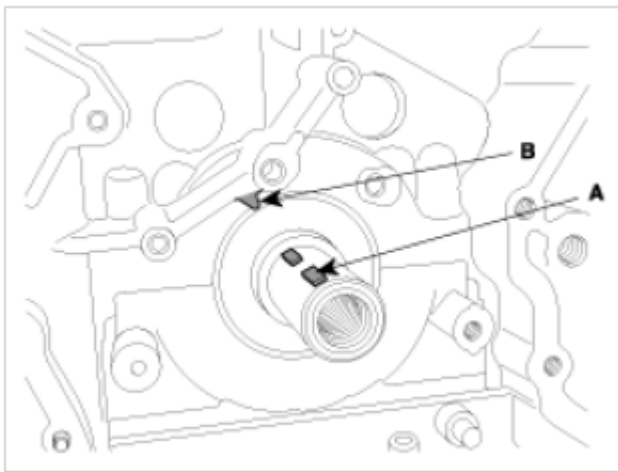
### Installation

1. Install the jack to the upper oil pan.



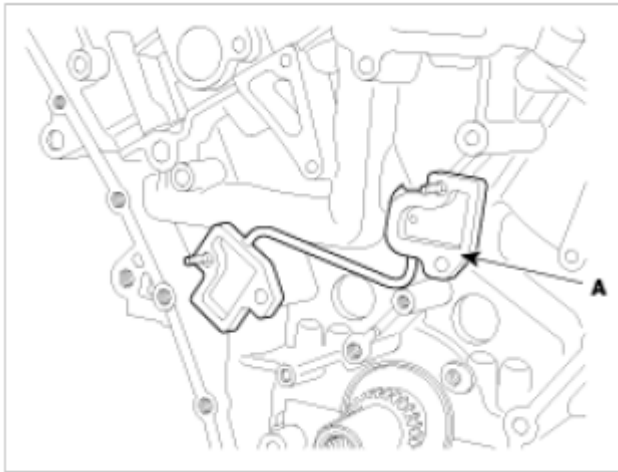
**Fig. 92: Locating Upper Oil Pan**

2. The key (A) of crankshaft should be aligned with the timing mark (B) of timing chain cover. As a result of this, the piston of No. 1 cylinder is placed at the top dead center on compression stroke.



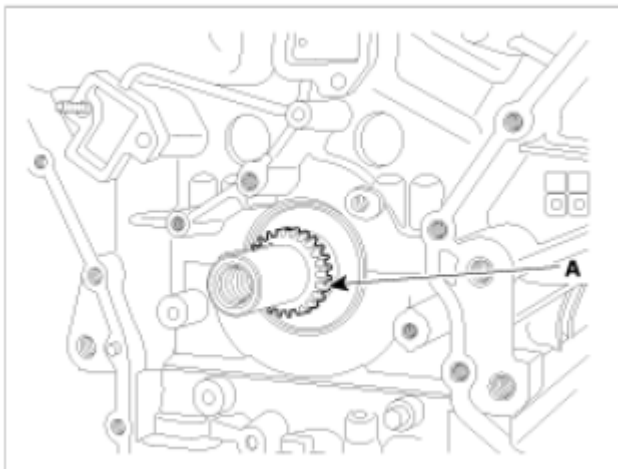
**Fig. 93: Identifying Key And Timing Mark On Timing Chain Cover**

3. Install the tensioner adapter assembly (A).



**Fig. 94: Identifying Tensioner Adapter Assembly**

4. Install the crankshaft sprocket (A) (LH camshaft drive).

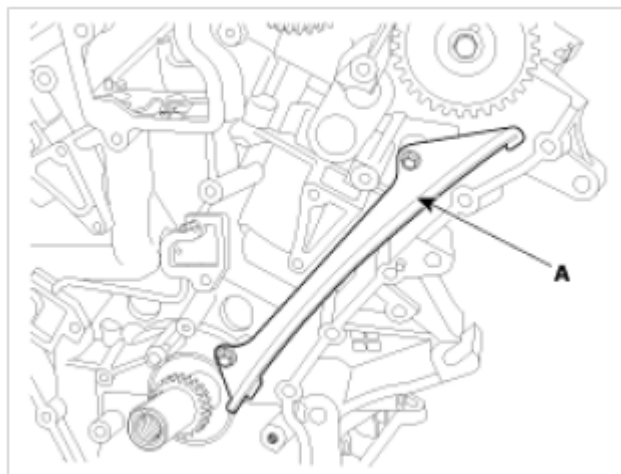


**Fig. 95: Identifying Crankshaft Sprocket (LH Camshaft Drive)**

5. Install the LH timing chain guide (A).

**Tightening torque**

19.60 ~ 24.50 N.m (2.0 ~ 2.5 kgf.m, 14.17 ~ 18.08 lb-ft)



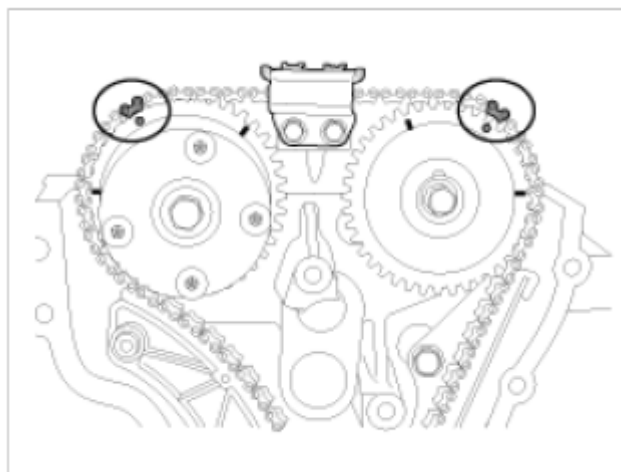
**Fig. 96: Identifying LH Timing Chain Guide**

6. Install the LH timing chain.

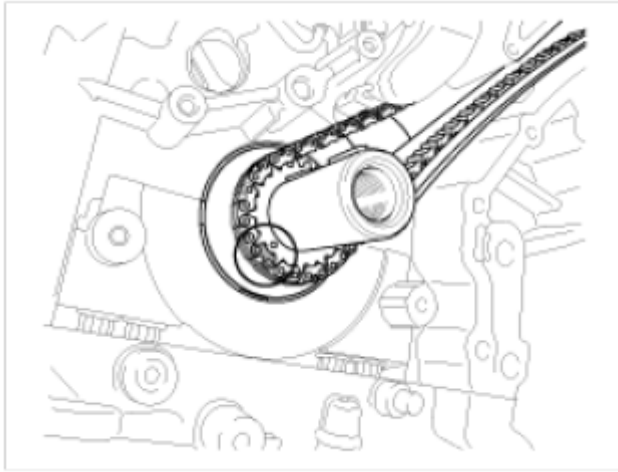
To install the timing chain with no slack between each shaft (cam, crank), follow the below procedure.

Crankshaft sprocket --> Timing chain guide --> Exhaust camshaft sprocket --> Intake camshaft sprocket.

The timing mark of each sprockets should be matched with timing mark (color link) of timing chain at installing timing chain.



**Fig. 97: Identifying Timing Mark On Exhaust Camshaft Sprocket And Intake Camshaft Sprocket**



**Fig. 98: Identifying LH Timing Chain**

7. Install the LH timing chain tensioner arm (B).

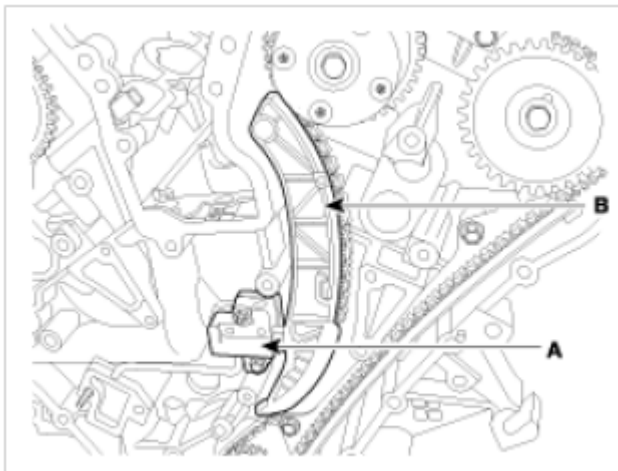
**Tightening torque**

18.62 ~ 21.56 N.m (1.9 ~ 2.2 kgf.m, 13.74 ~ 15.91 lb-ft)

8. Install the chain tensioner (A).

**Tightening torque**

9.80 ~ 11.76 N.m (1.0 ~ 1.2 kgf.m, 7.23 ~ 8.68 lb-ft)

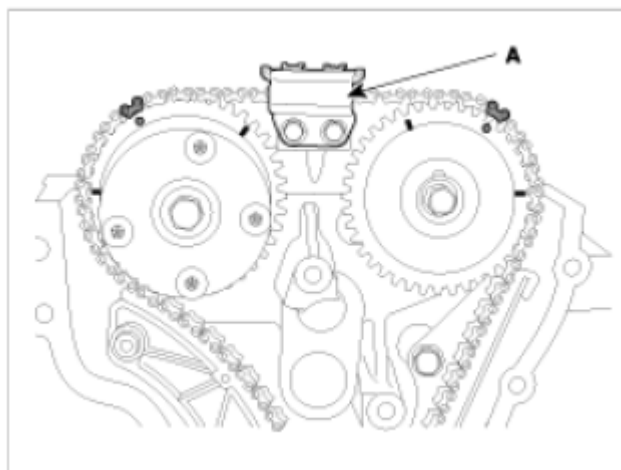


**Fig. 99: Identifying LH Timing Chain Tensioner Arm And Chain Tensioner**

9. Install the LH cam-to-cam guide (A).

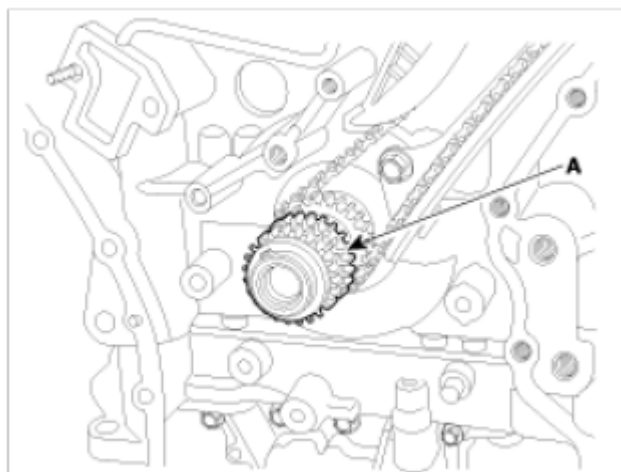
**Tightening torque**

9.80 ~ 11.76 N.m (1.0 ~ 1.2 kgf.m, 7.23 ~ 8.68 lb-ft)



**Fig. 100: Identifying LH Cam-To-Cam Guide**

10. Install the crankshaft sprocket (A) (O/P & RH camshaft drive).

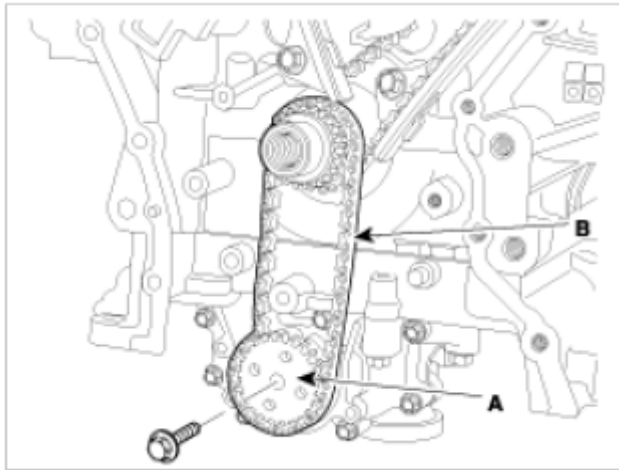


**Fig. 101: Identifying Crankshaft Sprocket (O/P & RH Camshaft Drive)**

11. Install the oil pump chain (B) and the oil pump sprocket (A).

**Tightening torque**

18.62 ~ 21.56 N.m (1.9 ~ 2.2 kgf.m, 13.74 ~ 15.91 lb-ft)

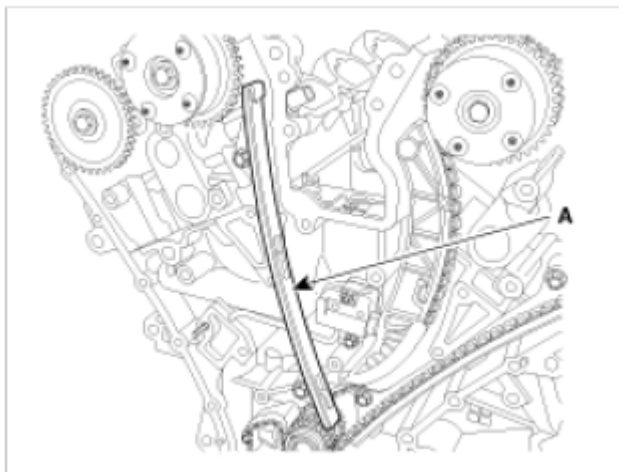


**Fig. 102: Identifying Oil Pump Chain And Oil Pump Sprocket With Mounting Bolt**

12. Install the RH timing chain guide (A).

**Tightening torque**

19.60 ~ 24.50 N.m (2.0 ~ 2.5 kgf.m, 14.17 ~ 18.08 lb-ft)



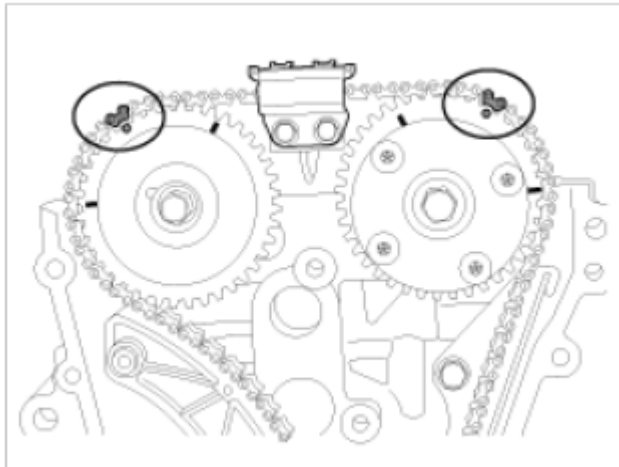
**Fig. 103: Identifying RH Timing Chain Guide**

13. Install the RH timing chain.

To install the timing chain with no slack between each shaft (cam, crank), follow the below procedure.

Crankshaft sprocket --> Intake camshaft sprocket --> Exhaust camshaft sprocket.

The timing mark of each sprockets should be matched with timing mark (color link) of timing chain at installing timing chain.



**Fig. 104: Identifying Timing Mark On Intake Camshaft Sprocket And Exhaust Camshaft Sprocket**



**Fig. 105: Identifying Timing Mark On Crankshaft Sprocket**

14. Install the RH timing chain tensioner arm (B).

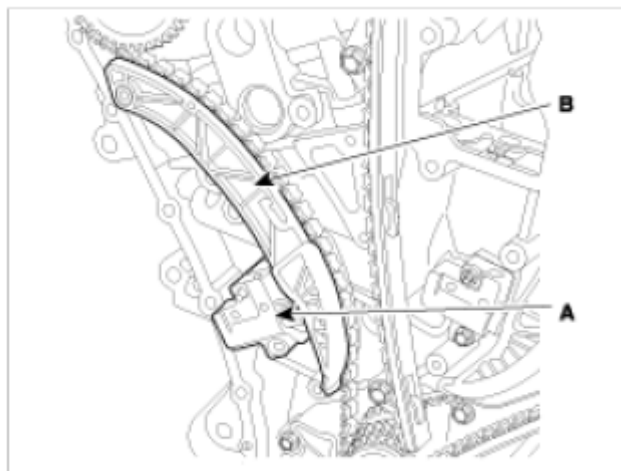
**Tightening torque**

18.62 ~ 21.56 N.m (1.9 ~ 2.2 kgf.m, 13.74 ~ 15.91 lb-ft)

15. Install the RH timing chain auto tensioner(A).

**Tightening torque**

9.80 ~ 11.76 N.m (1.0 ~ 1.2 kgf.m, 7.23 ~ 8.68 lb-ft)

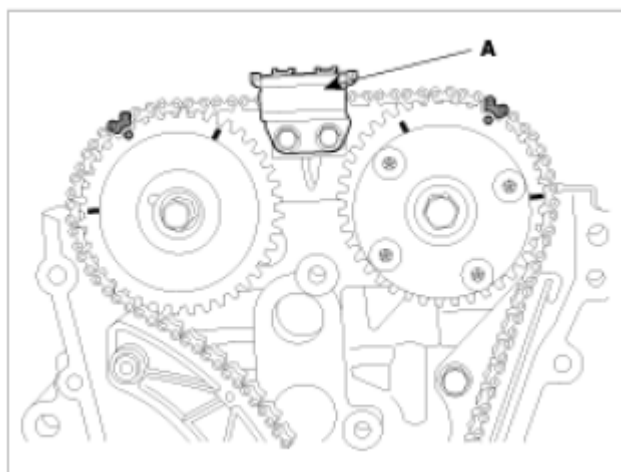


**Fig. 106: Identifying RH Timing Chain Auto Tensioner And RH Timing Chain Tensioner Arm**

16. Install the RH cam-to-cam guide (A).

**Tightening torque**

9.80 ~ 11.76 N.m (1.0 ~ 1.2 kgf.m, 7.23 ~ 8.68 lb-ft)

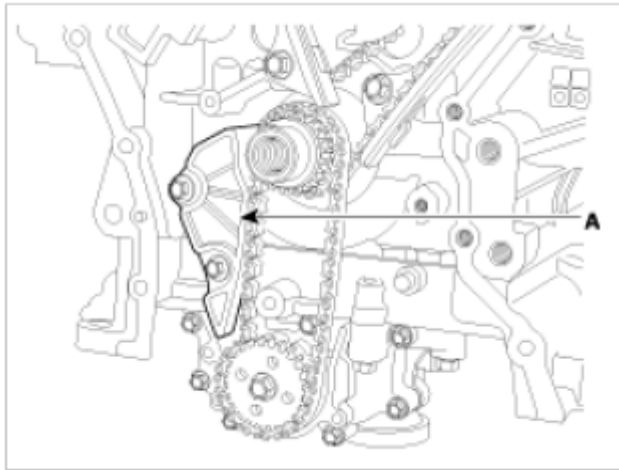


**Fig. 107: Identifying RH Cam-To-Cam Guide**

17. Install the oil pump chain guide (A).

**Tightening torque**

9.80 ~ 11.76 N.m (1.0 ~ 1.2 kgf.m, 7.23 ~ 8.68 lb-ft)

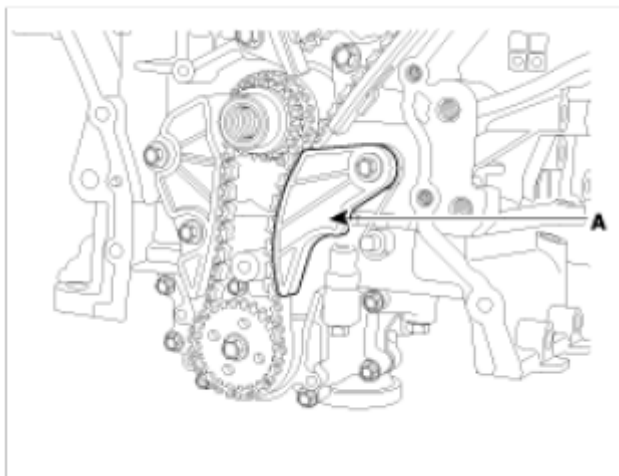


**Fig. 108: Identifying Oil Pump Chain Guide**

18. Install the oil pump chain tensioner assembly (A).

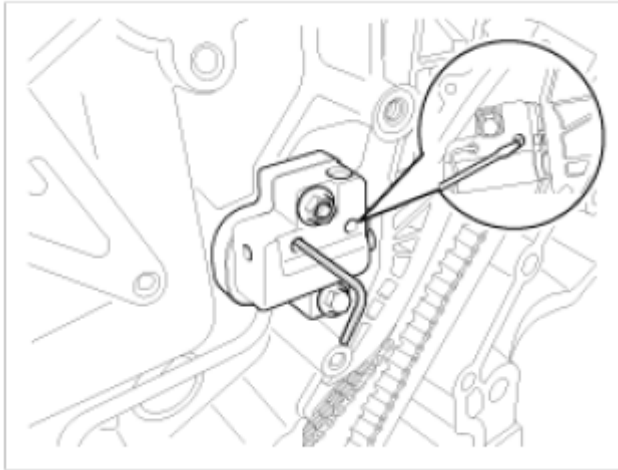
**Tightening torque**

9.80 ~ 11.76 N.m (1.0 ~ 1.2 kgf.m, 7.23 ~ 8.68 lb-ft)

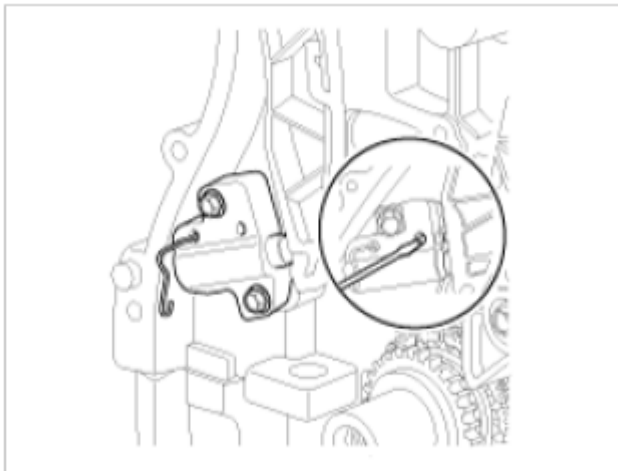


**Fig. 109: Identifying Oil Pump Chain Tensioner Assembly**

19. Pull out the pins of hydraulic tensioner (LH & RH).



**Fig. 110: Pulling Out Pins Of Hydraulic Tensioner (LH)**

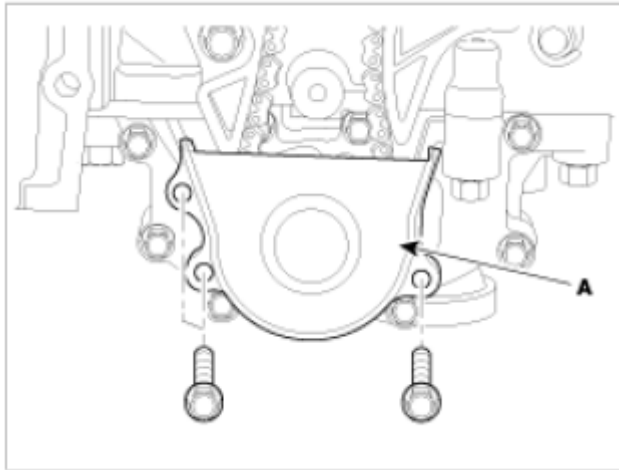


**Fig. 111: Pulling Out Pins Of Hydraulic Tensioner (RH)**

20. Install the oil pump chain cover (A).

**Tightening torque**

9.80 ~ 11.76 N.m (1.0 ~ 1.2 kgf.m, 7.23 ~ 8.68 lb-ft)



**Fig. 112: Identifying Oil Pump Chain Cover With Mounting Bolts**

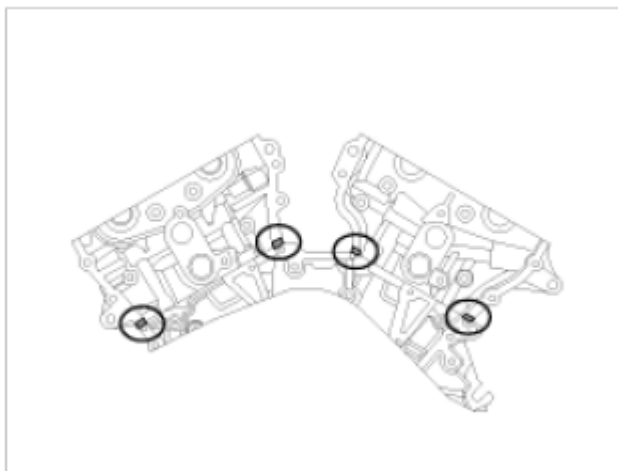
21. After rotating the crankshaft 2 revolutions in regular direction (clockwise viewed from front), confirm the timing mark.

**NOTE: Always turn the crankshaft clockwise.**

22. Install the timing chain cover.
1. The sealant locations on chain cover and on counter parts (cylinder head, cylinder block, and lower oil pan) must be free of engine oil and etc.
  2. Before assembling the timing chain cover, the liquid sealant TB 1217H should be applied on the gap between cylinder head and cylinder block.

The part must be assembled within 5 minutes after sealant was applied.

**Bead width:** 2.5 mm (0.1 in.)



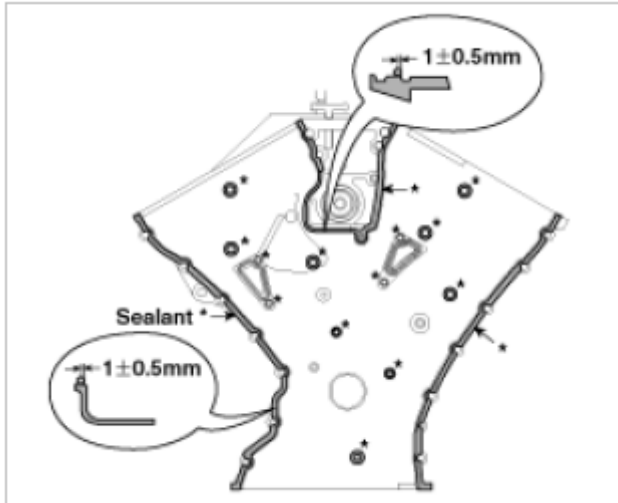
**Fig. 113: Identifying Timing Chain Cover**

3. After applying liquid sealant TB1217H on timing chain cover.

The part must be assembled within 5 minutes after sealant was applied.

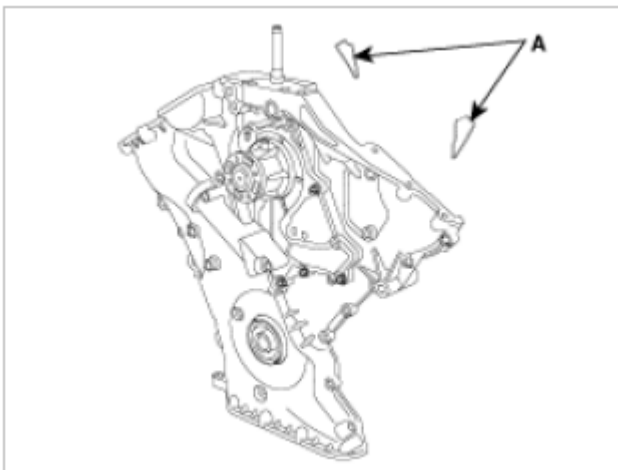
Sealant should be applied without discontinuity.

**Bead width: 2.5 mm (0.1 in.)**



**Fig. 114: Identifying Timing Chain Cover Liquid Sealant TB1217H Applying Dimensions**

4. Install the new gasket (A) to the timing chain cover.



**Fig. 115: Identifying Timing Chain Cover Gasket**

**NOTE:** During timing cover installation, care not to take off applied sealant on the timing cover by contact with other parts.

5. The dowel pins on the cylinder block and holes on the timing chain cover should be used as a reference in order to assemble the timing chain cover to be in exact position.

**Tightening torque**

B(17):

18.62 ~ 21.56 N.m (1.9 ~ 2.2 kgf.m, 13.74 ~ 15.91 lb-ft)

C(4):

9.80 ~ 11.76 N.m (1.0 ~ 1.2 kgf.m, 7.23 ~ 8.68 lb-ft)

D(1):

58.80 ~ 68.80 N.m (6.0 ~ 7.0 kgf.m, 43.40 ~ 50.63 lb-ft)

E(1):

58.80 ~ 68.80 N.m (6.0 ~ 7.0 kgf.m, 43.40 ~ 50.63 lb-ft)

F(2):

24.50 ~ 26.46 N.m (2.5 ~ 2.7 kgf.m, 18.08 ~ 19.53 lb-ft)

G(4):

21.56 ~ 23.52 N.m (2.2 ~ 2.4 kgf.m, 15.91 ~ 17.36 lb-ft)

H(1):

9.80 ~ 11.76 N.m (1.0 ~ 1.2 kgf.m, 7.23 ~ 8.68 lb-ft)

I(1):

9.80 ~ 11.76 N.m (1.0 ~ 1.2 kgf.m, 7.23 ~ 8.68 lb-ft)

J(1):

9.80 ~ 11.76 N.m (1.0 ~ 1.2 kgf.m, 7.23 ~ 8.68 lb-ft)

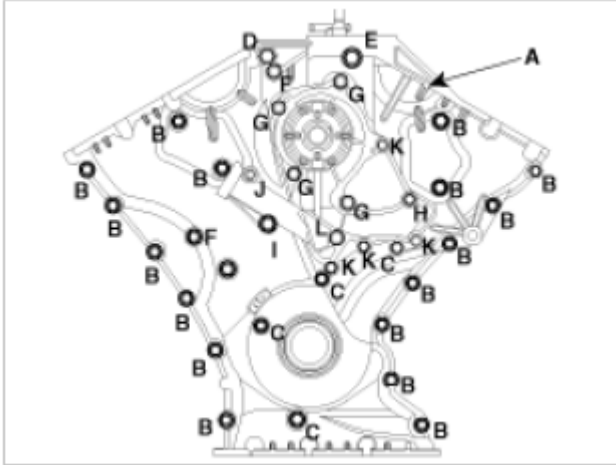
K(4):

9.80 ~ 11.76 N.m (1.0 ~ 1.2 kgf.m, 7.23 ~ 8.68 lb-ft)

L(1):

21.56 ~ 26.46 N.m (2.2 ~ 2.7 kgf.m, 15.91 ~ 19.53 lb-ft)

- New bolt

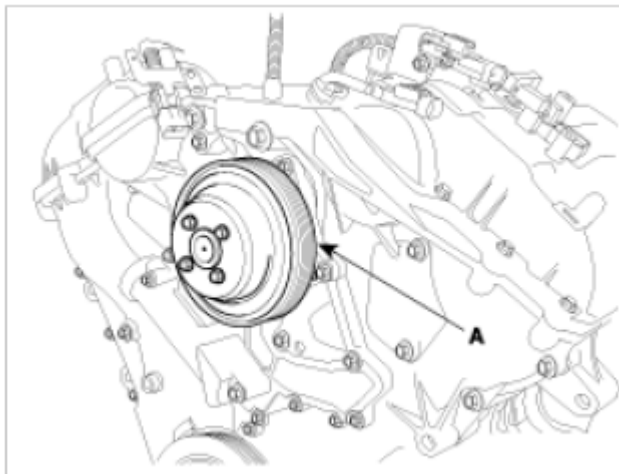


**Fig. 116: Identifying Cylinder Block Mounting Dowel Pins Tightening Sequence**

6. The firing and/or blow out test should not be performed within 30 minutes after the timing chain cover was assembled.
23. Install the water pump pulley (A).

**Tightening torque**

7.84 ~ 9.80 N.m (0.8 ~ 1.0 kgf.m, 5.78 ~ 7.23 lb-ft)



**Fig. 117: Identifying Water Pump Pulley**

24. Install the drive belt auto tensioner (A).

**Tightening torque**

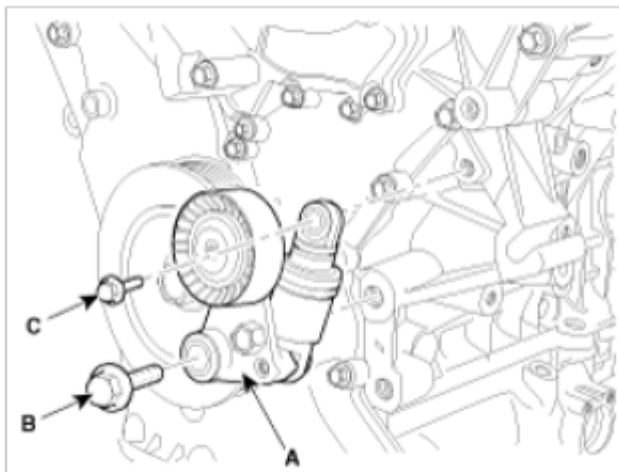
Bolt(B):

81.39 ~ 85.32 N.m (8.3 ~ 8.7 kgf.m, 60.03 ~ 62.93 lb-ft)

Bolt(C):

17.64 ~ 21.56 N.m (1.8 ~ 2.2 kgf.m, 13.02 ~ 15.91 lb-ft)

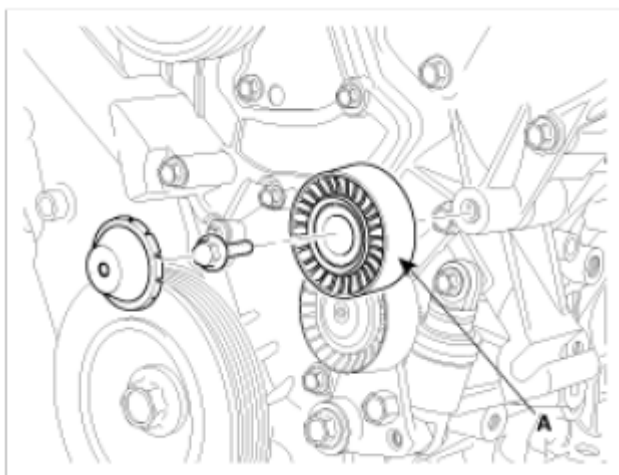
25. Install the drive belt idler (A).



**Fig. 118: Identifying Drive Belt Idler With Mounting Bolt**

**Tightening torque**

52.92 ~ 57.82 N.m (5.4 ~ 5.9 kgf.m, 39.06 ~ 42.67 lb-ft)

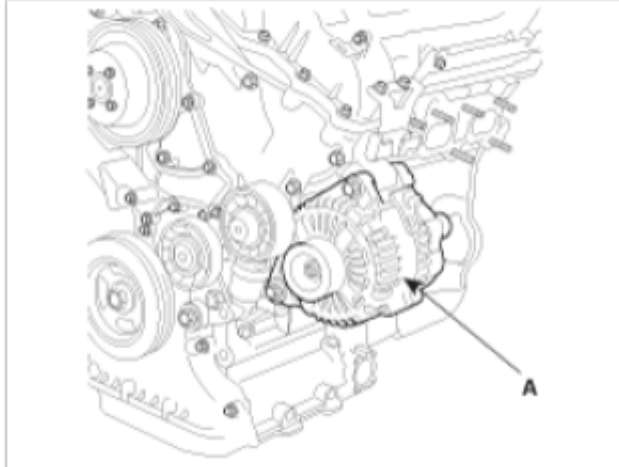


**Fig. 119: Identifying Drive Belt Idler With Mounting Bolt**

26. Install the alternator (A).

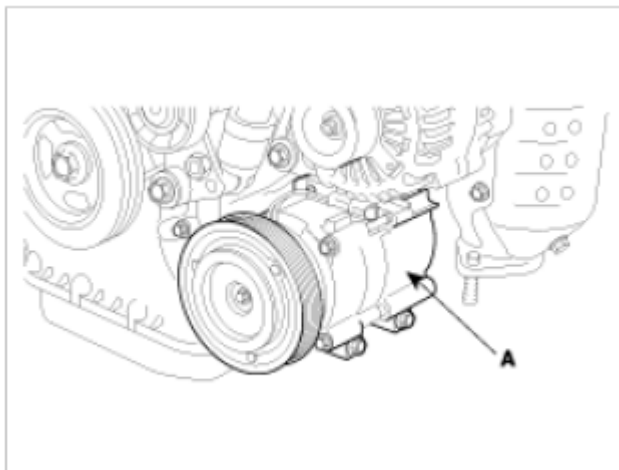
### Tightening torque

26.48 ~ 33.34 N.m (2.7 ~ 3.4 kgf.m, 19.53 ~ 24.59 lb-ft)



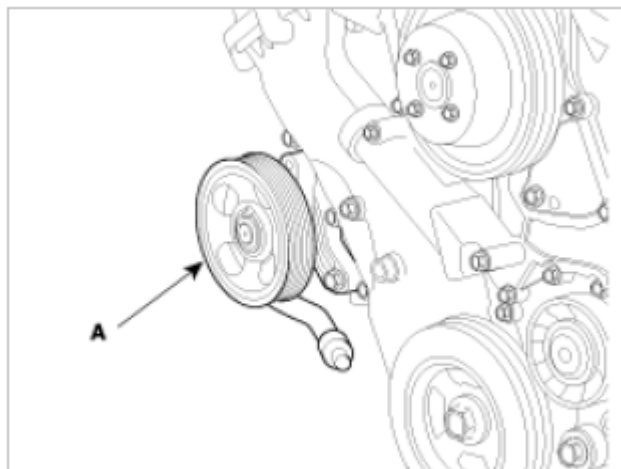
**Fig. 120: Identifying Alternator**

27. Install the air conditioner compressor (A). (Refer to HA group)



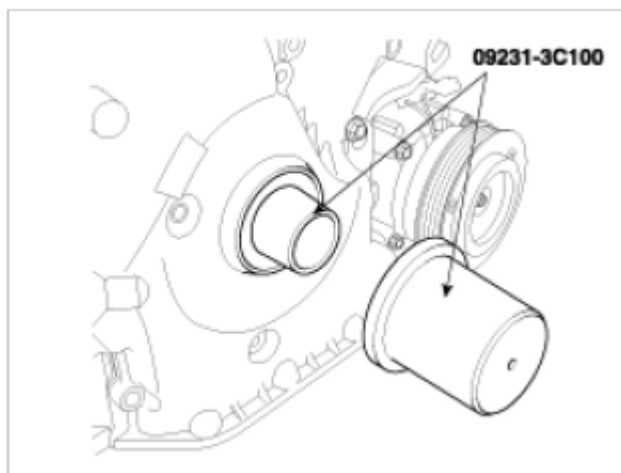
**Fig. 121: Identifying Air Conditioner Compressor**

28. Install the power steering pump (A). (Refer to ST group)



**Fig. 122: Identifying Power Steering Pump**

29. Lower the engine assembly by using the jack.
30. Using SST (09231-3C100), install timing chain cover oil seal.

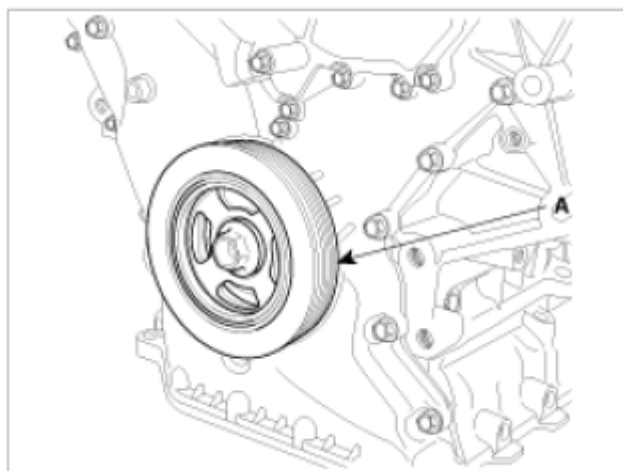


**Fig. 123: Installing Timing Chain Cover Oil Seal Using SST (09231-3C100)**

31. Install the crankshaft damper pulley (A).

**Tightening torque**

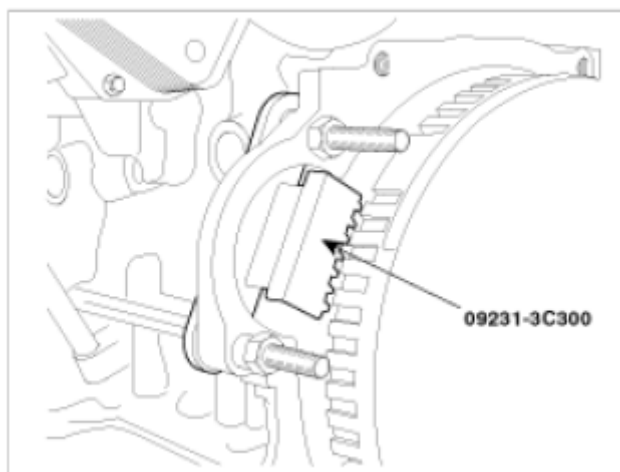
284.2~303.8 N.m (29.0~31.0 kgf.m, 209.76~224.22 lb-ft)



**Fig. 124: Identifying Crankshaft Damper Pulley**

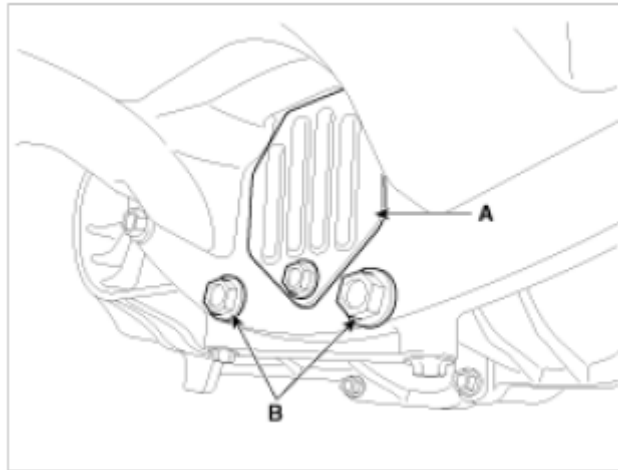
**NOTE:** There are two methods to hold the ring gear when installing or removing the crankshaft damper pulley.

- Install the SST (09231-3C300) to hold the ring gear after removing the starter.



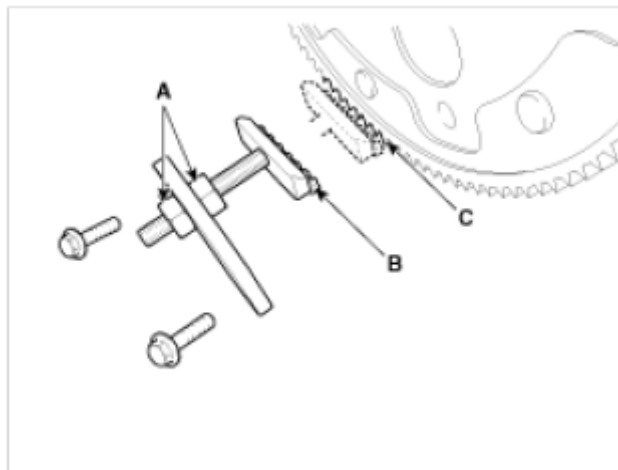
**Fig. 125: Installing Crankshaft Damper Pulley Using SST (09231-3C300)**

- Install the SST (09231-3D100) to hold the ring gear after removing the dust cover.
1. Remove the front muffler. (Refer to Intake And Exhaust system)
  2. Remove the dust cover (A) on the bottom of the upper oil pan and unfasten the two transaxle mounting bolts (B).



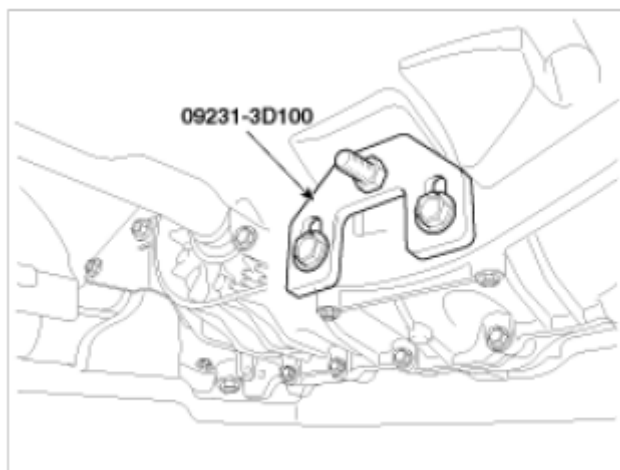
**Fig. 126: Identifying Dust Cover And Transaxle Mounting Bolts**

3. Adjust the length of the holder nuts (A) so that the front plate of the holder (B) puts in the ring gear (C) teeth.
4. Fasten the two transaxle mounting bolts in the original mounted holes.



**Fig. 127: Identifying Holder Nuts, Holder And Ring Gear With Mounting Bolts**

5. Install the SST (09231-3D100) using the two mounting bolts. Tighten the bolts and nuts of the holder securely.



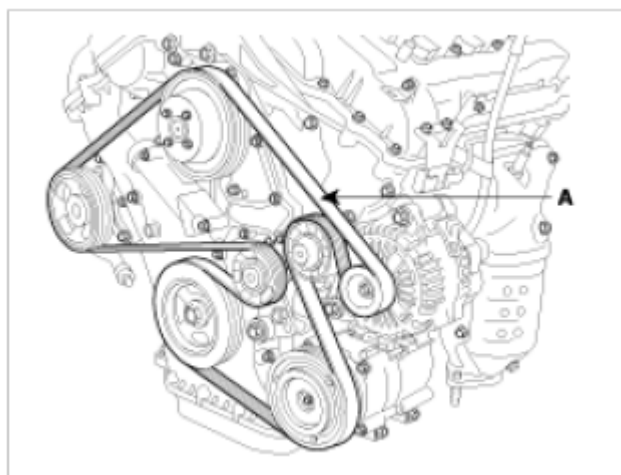
**Fig. 128: Installing SST (09231-3D100) Using Mounting Bolts**

32. Install the drive belt (A).

Crankshaft pulley --> A/C pulley --> idler pulley --> alternator pulley --> water pump pulley --> P/S pump pulley --> tensioner pulley.

Rotate auto tensioner arm in the counterclockwise moving auto tensioner pulley bolt with wrench.

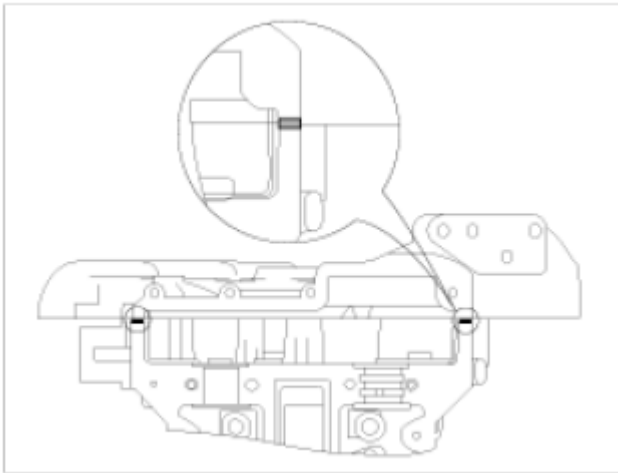
After putting belt on auto tensioner pulley, release the auto tensioner pulley slowly.



**Fig. 129: Identifying Drive Belt**

33. Install the cylinder head cover.
1. The hardening sealant located on the upper area between timing chain cover and cylinder head should be removed before assembling cylinder head cover.
  2. After applying sealant (TB1217H), it should be assembled within 5 minutes.

**Bead width: 2.5 mm (0.1 in.)**

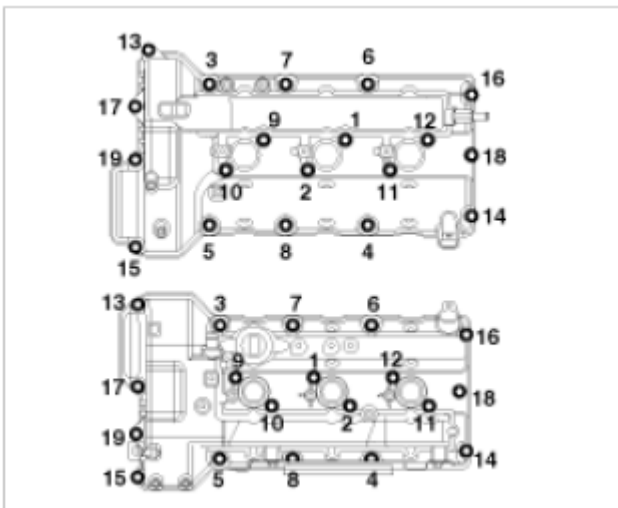


**Fig. 130: Identifying Cylinder Head Cover Sealant Applying Area**

3. The firing and/or blow out test should not be performed within 30 minutes after the cylinder head cover was assembled.
4. Install the cylinder head cover bolts as following method.

**Tightening torque**

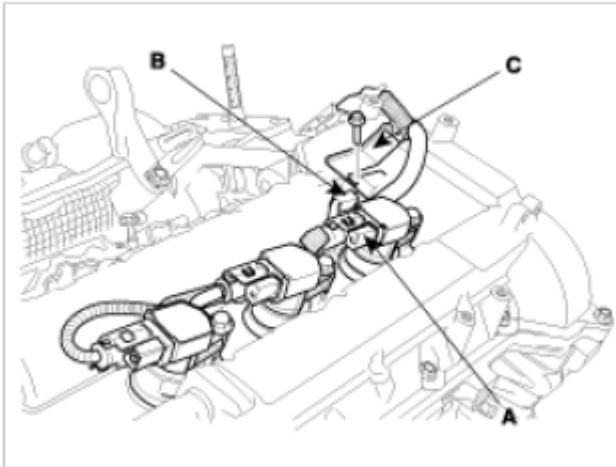
9.80 ~ 11.76 N.m (1.0 ~ 1.2 kgf.m, 7.23 ~ 8.68 lb-ft)



**Fig. 131: Identifying Cylinder Head Cover Bolts Tightening Sequence**

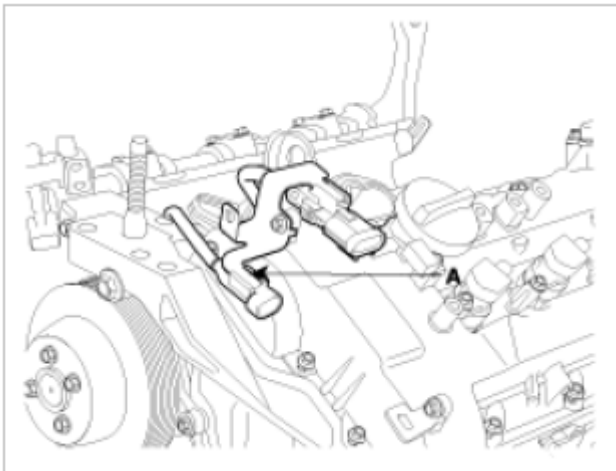
**CAUTION: Do not reuse cylinder head cover gasket.**

5. Install the ignition coil.
6. Connect the RH ignition coil connector (A), the condenser connector (B) and install the wiring bracket (C).



**Fig. 132: Identifying RH Ignition Coil Connector, Condenser Connector And Wiring Bracket**

7. Install the connector bracket (A) from the LH cylinder head cover.

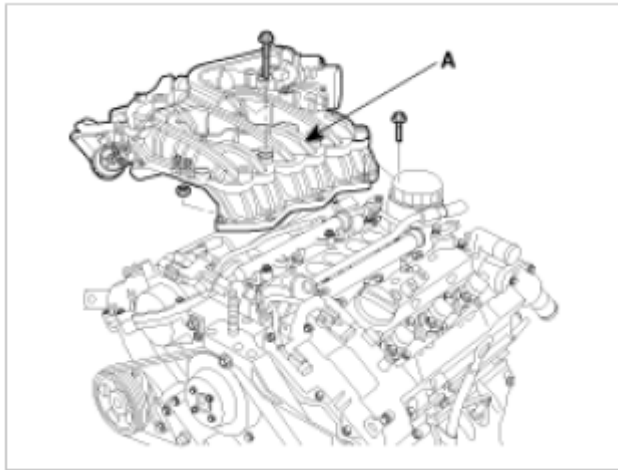


**Fig. 133: Identifying LH Cylinder Head Cover Connector Bracket**

34. Install the surge tank.
  1. Install the surge tank (A).

**Tightening torque**

9.80 ~ 11.76 N.m (1.0 ~ 1.2 kgf.m, 7.23 ~ 8.68 lb-ft)

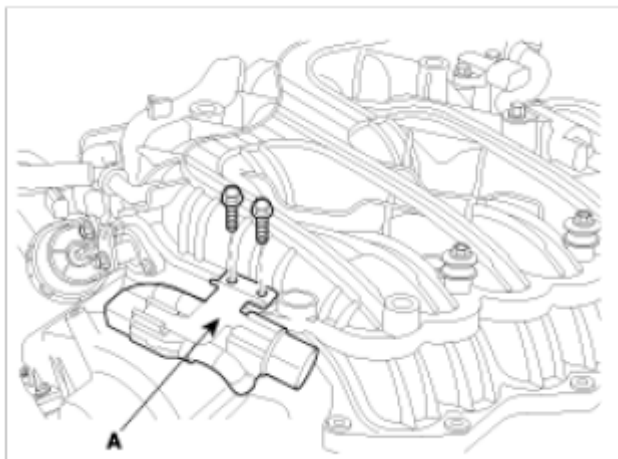


**Fig. 134: Identifying Surge Tank With Mounting Bolts**

2. Install the connector bracket(A) on the surge tank.

**Tightening torque**

6.86 ~ 10.78 N.m (0.7 ~ 1.1 kgf.m, 5.06 ~ 7.96 lb-ft)

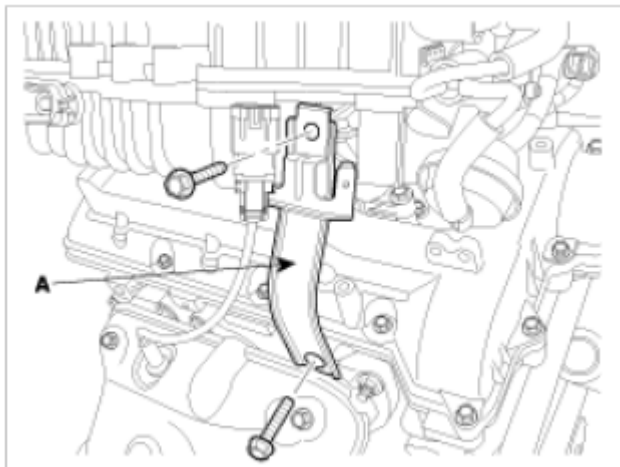


**Fig. 135: Identifying Surge Tank Connector Bracket With Mounting Bolts**

3. Install the surge tank stay.

**Tightening torque**

27.44 ~ 31.36 N.m (2.8 ~ 3.2 kgf.m, 20.25 ~ 23.14 lb-ft)

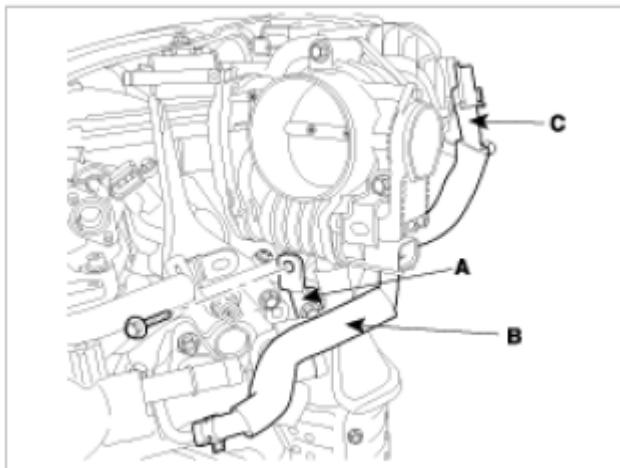


**Fig. 136: Identifying Surge Tank Stay With Mounting Bolts**

4. Connect the brake vacuum hose.
5. Connect the PCV hose (C).
6. Connect the water hoses (B) to the ETC.
7. Install the ETC bracket (A).

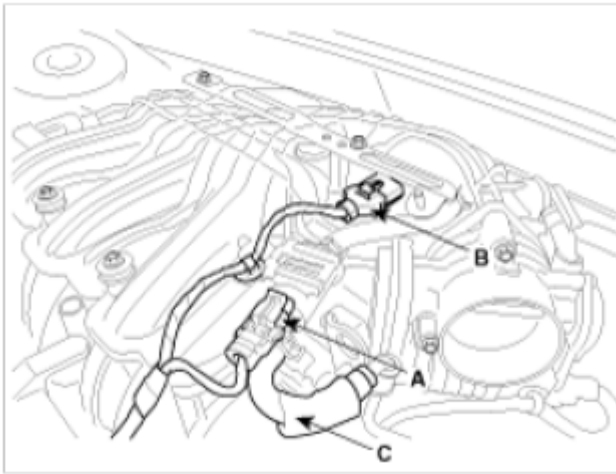
**Tightening torque**

15.68 ~ 25.48 N.m (1.6 ~ 2.6 kgf.m, 11.57 ~ 18.80 lb-ft)



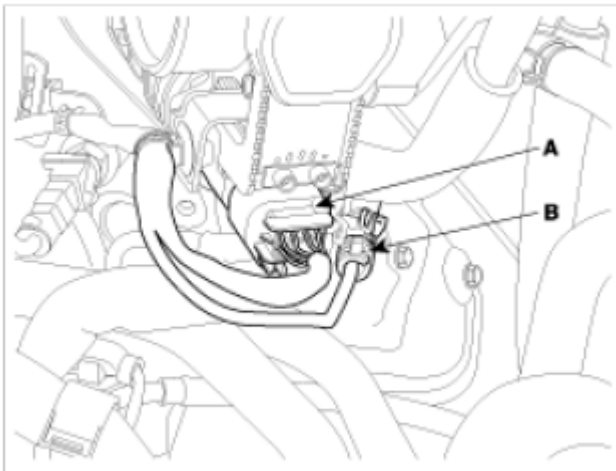
**Fig. 137: Identifying ETC Bracket, Water Hoses And PCV Hose**

8. Connect the PCSV connector (A), the MAP sensor connector (B) and the PCSV hose (C).



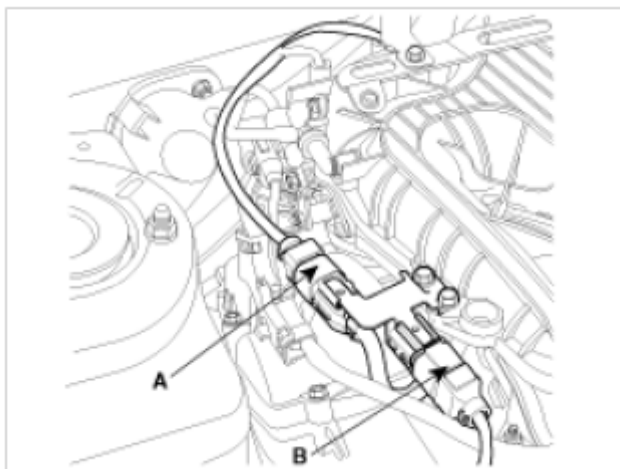
**Fig. 138: Identifying PCSV Connector, Map Sensor Connector And PCSV Hose**

9. Connect the ETC connector (A) and the knock sensor connector (B).



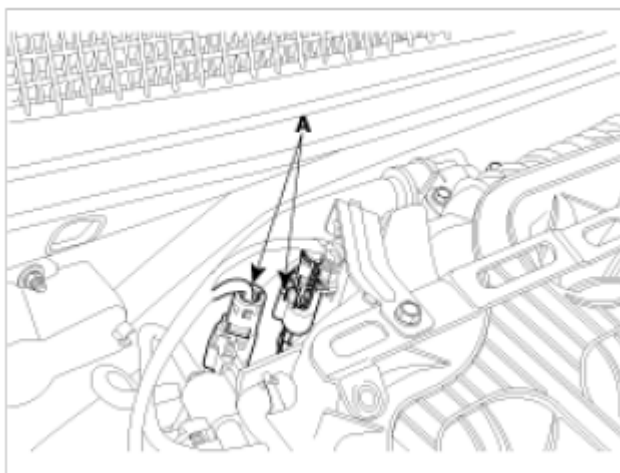
**Fig. 139: Identifying ETC Connector And Knock Sensor Connector**

10. Connect the RH injector connector (A) and the ignition coil connector (B).



**Fig. 140: Identifying RH Injector Connector And Ignition Coil Connector**

11. Connect the RH oxygen sensor connector (A).



**Fig. 141: Identifying RH Oxygen Sensor Connector**

35. Install the no.1 engine mounting (A) through the lower position of A/C pipe line.

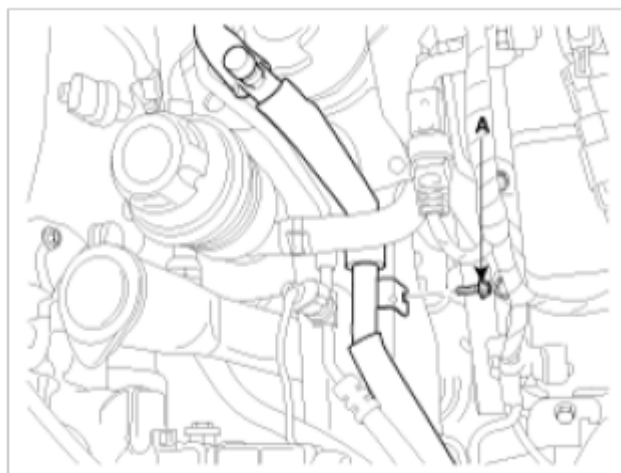
**Tightening torque**

49.03 ~ 63.74 N.m (5.0 ~ 6.5 kgf.m, 36.17 ~ 47.01 lb-ft)



**Fig. 142: Identifying No.1 Engine Mounting**

36. Install the A/C pipe bracket mounting bolt (A).

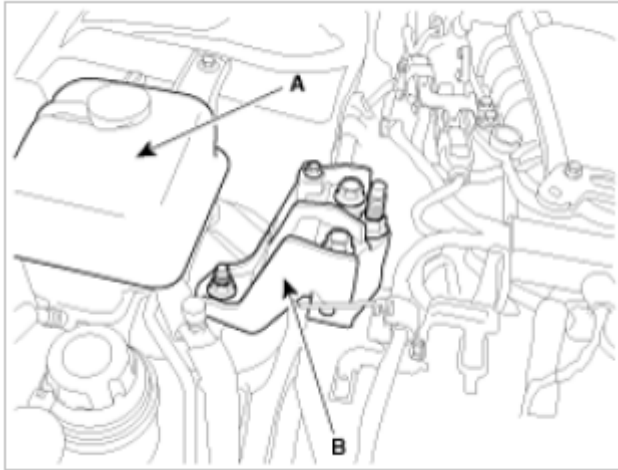


**Fig. 143: Identifying A/C Pipe Bracket Mounting Bolt**

37. Install the engine coolant reservoir tank (A).
38. Install the engine mounting bracket (B).

**Tightening torque**

63.74 ~ 83.36 N.m (6.5 ~ 8.5 kgf.m, 47.01 ~ 61.48 lb-ft)

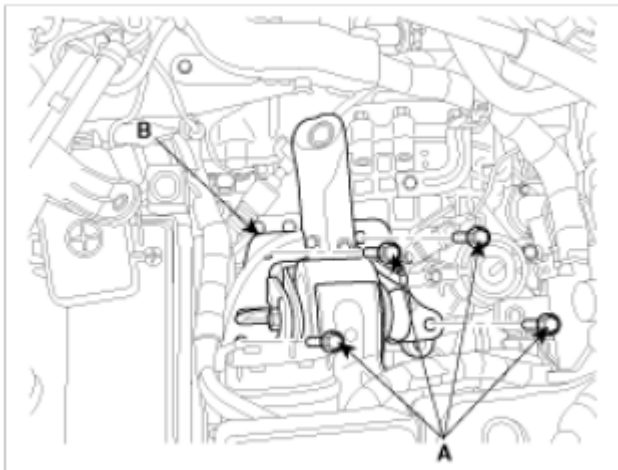


**Fig. 144: Identifying Engine Coolant Reservoir Tank And Engine Mounting Bracket**

39. Install the transaxle mounting bolts (A).

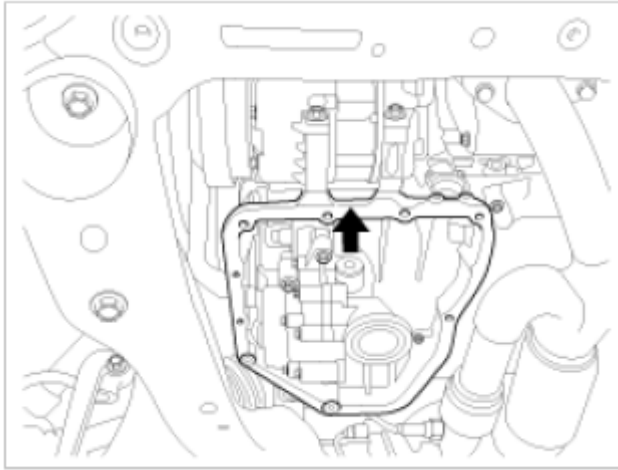
**Tightening torque**

49.03 ~ 63.74 N.m (5.0 ~ 6.5 kgf.m, 36.17 ~ 47.01 lb-ft)



**Fig. 145: Identifying Transaxle Mounting And Mounting Bolts**

40. Remove the jack from the upper oil pan.



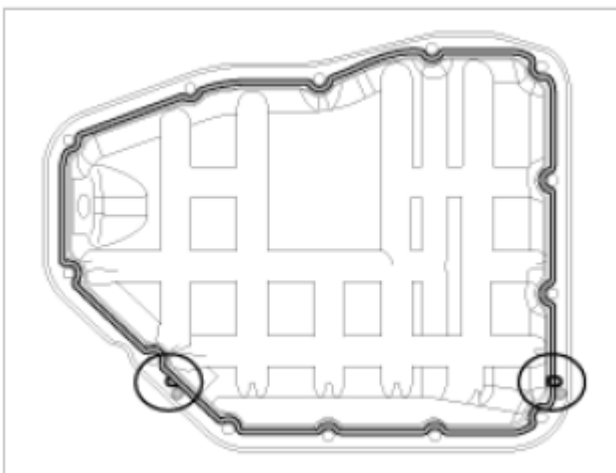
**Fig. 146: Locating Upper Oil Pan**

41. Install the lower oil pan.
  1. Using a gasket scraper, remove all the old packing material from the gasket surfaces.
  2. Before assembling the oil pan, the liquid sealant TB 1217H should be applied on oil pan.

The part must be assembled within 5 minutes after the sealant was applied.

**Bead width:** 2.5 mm (0.1 in.).

But marked area (\*) to be 5.0 mm (0.2 in.)



**Fig. 147: Identifying Lower Oil Pan Sealant Applying Area**

**CAUTION:**

- **Make clean the sealing face before assembling two parts.**
- **Remove harmful foreign matters on the sealing face before applying sealant.**

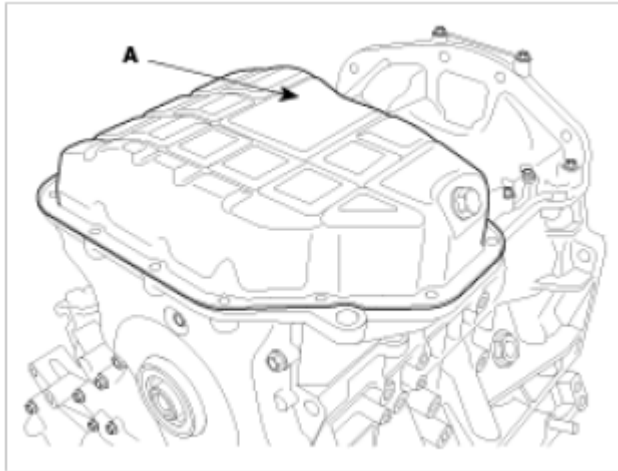
- When applying sealant gasket, sealant must not be protruded into the inside of oil pan.
- To prevent leakage of oil, apply sealant gasket to the inner threads of the bolt holes.

3. Install the oil pan (A).

Uniformly tighten the bolts in several passes.

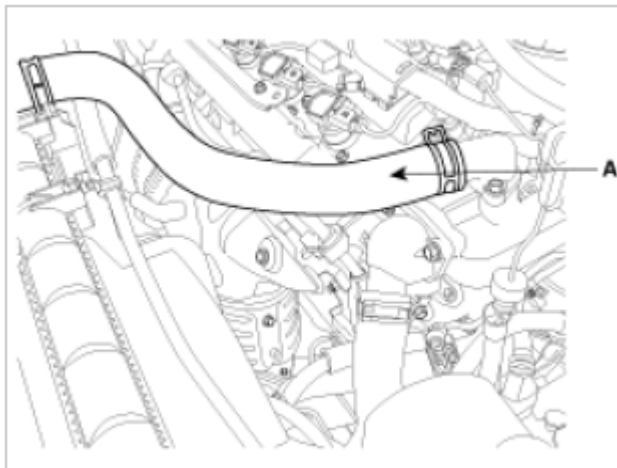
**Tightening torque**

9.80 ~ 11.76 N.m (1.0 ~ 1.2 kgf.m, 7.23 ~ 8.68 lb-ft)



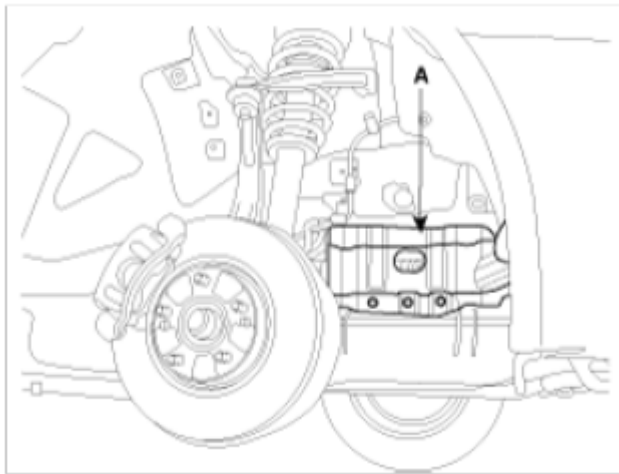
**Fig. 148: Identifying Oil Pan**

42. Install the upper radiator hose (A).



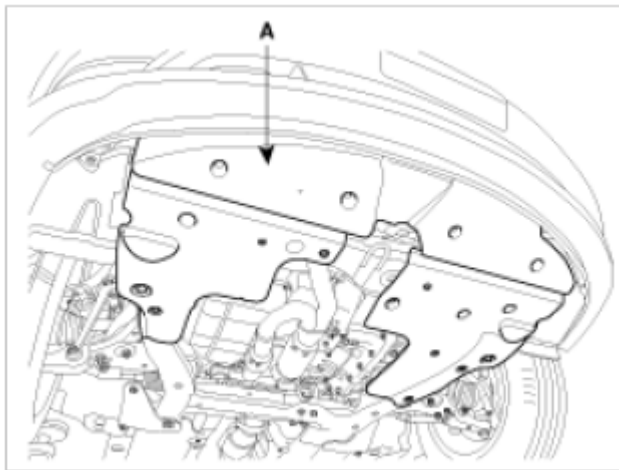
**Fig. 149: Identifying Upper Radiator Hose**

43. Install the side cover (A).



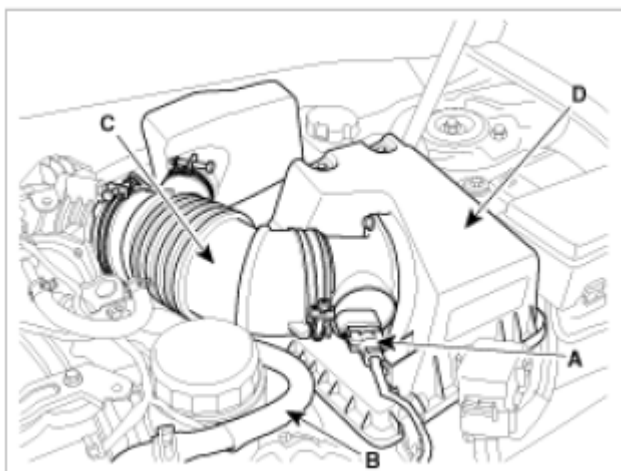
**Fig. 150: Identifying Side Cover**

44. Install the under cover (A).



**Fig. 151: Identifying Under Cover**

45. Install the front wheels.
46. Install the intake air hose and air cleaner assembly.
1. Install the intake air hose (C) and air cleaner (D).
  2. Connect the ECM connector.
  3. Connect the breather hose (B) from air cleaner hose.
  4. Connect the AFS connector (A).



**Fig. 152: Identifying AFS Connector, Breather Hose, Intake Air Hose And Air Cleaner**

47. Install the air duct.
48. Install the engine cover.
49. Connect the negative terminal from the battery.

**NOTE:**

- **Refill engine with engine oil.**
- **Refill radiator and reservoir tank with engine coolant.**
- **Bleed air from the cooling system.**
- **Start engine and let it run until it warms up. (until the radiator fan operates 3 or 4 times.)**
- **Turn Off the engine. Check the level in the radiator, add coolant if needed. This will allow trapped air to be removed from the cooling system.**
- **Put radiator cap on tightly, then run the engine again and check for leaks.**

## ACCESSORY DRIVE BELT

### INSPECTION

#### SPROCKETS, CHAIN TENSIONER, CHAIN GUIDE, CHAIN TENSIONER ARM

1. Check the camshaft sprocket and crankshaft sprocket for abnormal wear, cracks, or damage. Replace as necessary.
2. Inspect the tensioner arm and chain guide for abnormal wear, cracks, or damage. Replace as necessary.
3. Check that the tensioner piston moves smoothly when the ratchet pawl is released with thin rod.

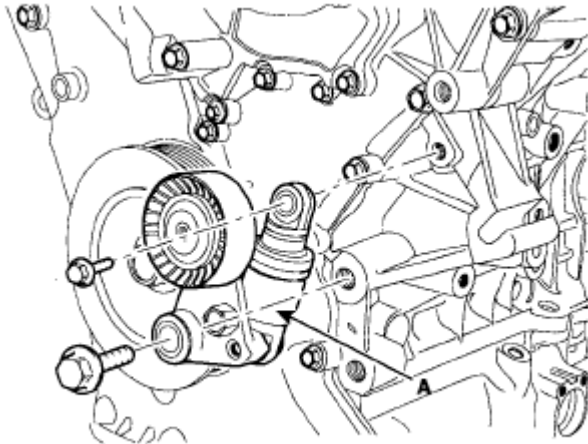
### INSTALLATION

1. Install drive belt auto tensioner (A).

**Tightening torque**

96.04 ~ 99.96 Nm (9.8 ~ 10.2 kgf.m, 70.85 ~ 73.74 lbf.ft)

17.64 ~ 21.56 Nm (1.8 ~ 2.2 kgf.m, 13.02 ~ 15.91 lbf.ft)



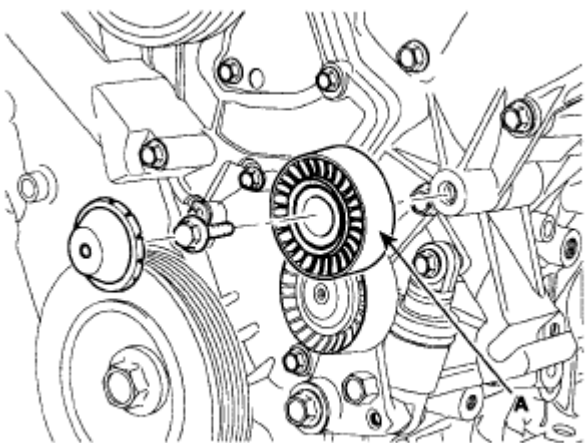
KDRF106A

**Fig. 153: Identifying Drive Belt Auto Tensioner**  
Courtesy of HYUNDAI MOTOR CO.

2. Install drive belt idler (A).

**Tightening torque**

52.92 ~ 57.82 Nm (5.4 ~ 5.9 kgf.m, 39.06 ~ 42.67 lbf.ft)



KDRF105A

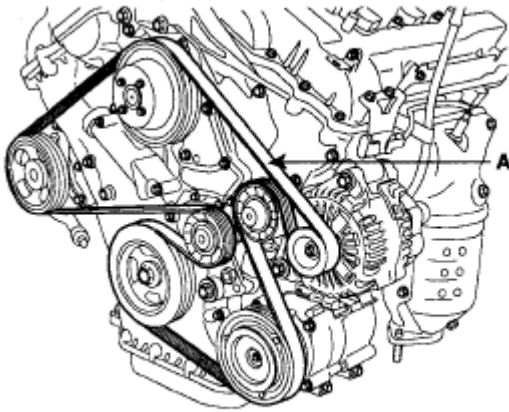
**Fig. 154: Identifying Drive Belt Idler**  
Courtesy of HYUNDAI MOTOR CO.

3. Install drive belt (A).

Crankshaft pulley --> A/C pulley --> idler pulley --> alternator pulley --> water pump pulley --> P/S pump pulley --> tensioner pulley.

Rotate auto tensioner arm in the counter-clockwise moving auto tensioner pulley bolt with wrench.

After putting belt on auto tensioner pulley, release the auto tensioner pulley slowly.

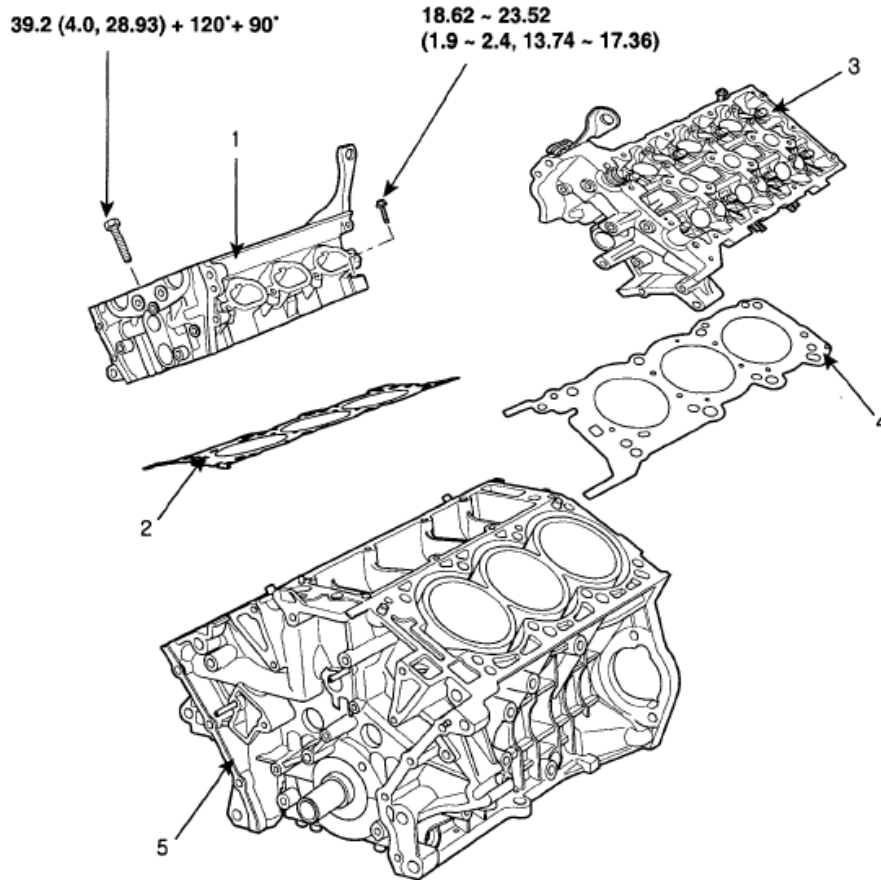


KDRF101A

**Fig. 155: Identifying Drive Belt**  
Courtesy of HYUNDAI MOTOR CO.

## CYLINDER HEAD ASSEMBLY

### COMPONENTS

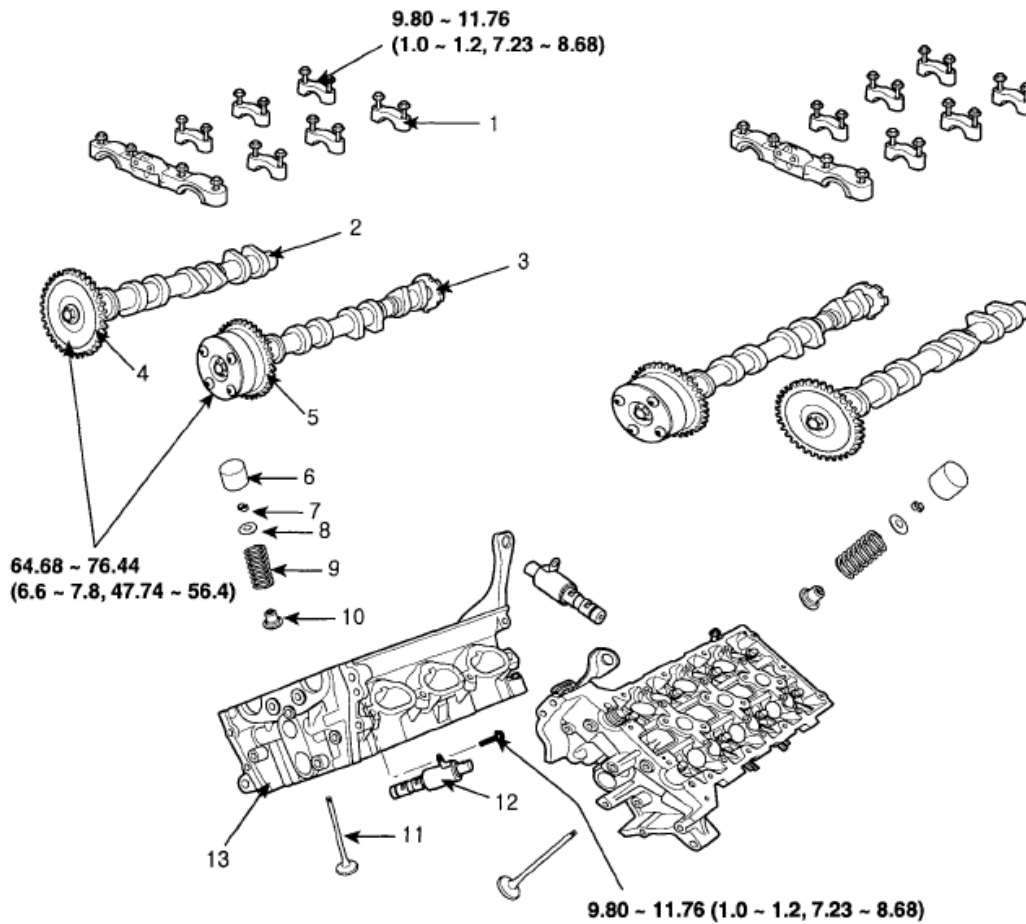


**TORQUE : N.m (kgf.m, lbf.ft)**

- 1. RH cylinder head
- 2. RH cylinder head gasket
- 3. LH cylinder head
- 4. LH cylinder head gasket
- 5. Cylinder block

EDRF003A

**Fig. 156: Exploded View Of Cylinder Head Assembly Components With Torque Specifications (1 Of 2)**  
Courtesy of HYUNDAI MOTOR CO.



**TORQUE : N.m (kgf.m, lbf.ft)**

- 1. Camshaft bearing cap
- 2. Exhaust camshaft
- 3. Intake camshaft
- 4. Exhaust camshaft sprocket
- 5. CVVT assembly

- 6. MLA
- 7. Retainer lock
- 8. Retainer
- 9. Valve spring
- 10. Valve stem seal

- 11. Valve
- 12. OCV
- 13. Cylinder head

EDRF004A

**Fig. 157: Exploded View Of Cylinder Head Assembly Components With Torque Specifications (2 Of 2)**  
 Courtesy of HYUNDAI MOTOR CO.

**REMOVAL**

**CAUTION:**

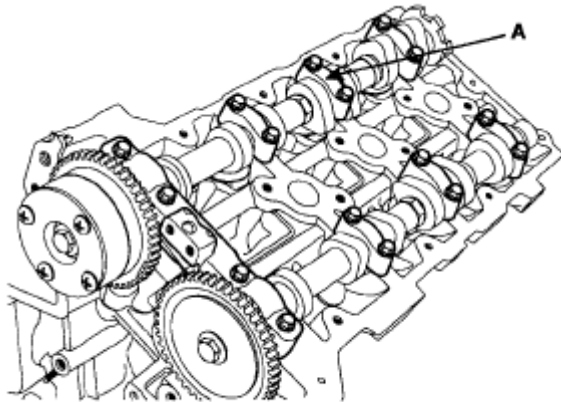
- Use fender covers to avoid damaging painted surfaces.
- To avoid damaging the cylinder head, wait until the engine coolant temperature drops below normal temperature before removing it.
- When handling a metal gasket, take care not to fold the gasket or damage the contact surface of the gasket.
- To avoid damage, unplug the wiring connectors carefully while holding the connector portion.

**NOTE:**

- Mark all wiring and hoses to avoid misconnection.
- Turn the crankshaft pulley so that the No. 1 piston is at top dead center. (See VALVE CLEARANCE INSPECTION AND ADJUSTMENT)

Engine removal is required for this procedure.

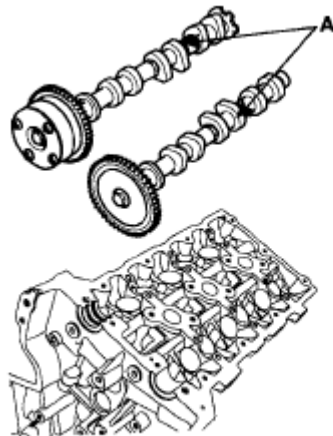
1. Remove exhaust manifold. (See EXHAUST MANIFOLD)
2. Remove intake manifold. (See REMOVAL)
3. Remove timing chain. (See REMOVAL)
4. Remove water temperature control assembly. (See WATER TEMPERATURE CONTROL ASSEMBLY)
5. Remove camshaft bearing cap (A).



KDRF196A

**Fig. 158: Identifying Camshaft Bearing Cap**  
Courtesy of HYUNDAI MOTOR CO.

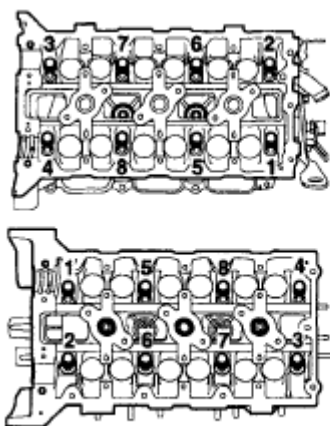
6. Remove camshaft assembly (A).



KDRF197A

**Fig. 159: Identifying Camshaft Assembly**  
Courtesy of HYUNDAI MOTOR CO.

7. Remove cylinder head bolts, then remove cylinder head.
  1. Uniformly loosen and remove the 16 cylinder head bolts, in several passes, in the sequence shown. Remove the 16 cylinder head bolts and plate washers.



KDRF199A

**Fig. 160: Identifying Cylinder Head Bolts Loosening Sequence**  
Courtesy of HYUNDAI MOTOR CO.

**CAUTION: Head warpage or cracking could result from removing bolts in an incorrect order.**

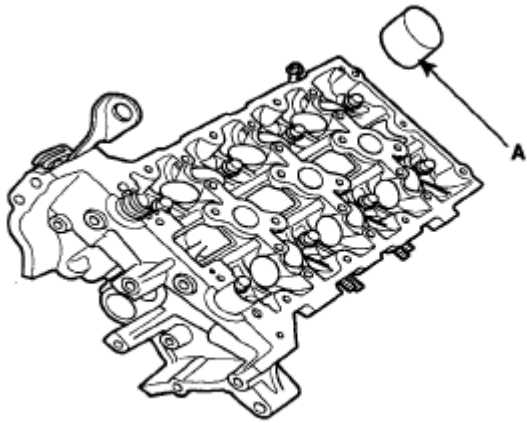
2. Lift the cylinder head from the dowels on the cylinder block and place the cylinder head on wooden blocks on a bench.

**CAUTION: Be careful not to damage the contact surfaces of the cylinder head and cylinder block.**

## DISASSEMBLY

**NOTE:** Identify MLA, valves and valve springs as they are removed so that each item can be reinstalled in its original position.

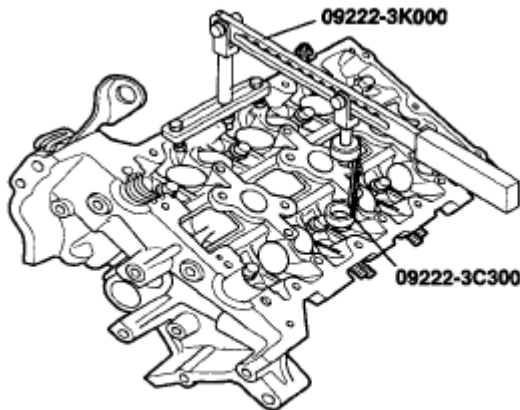
1. Remove MLAs (A).



KDRF200A

**Fig. 161: Identifying MLAs**  
Courtesy of HYUNDAI MOTOR CO.

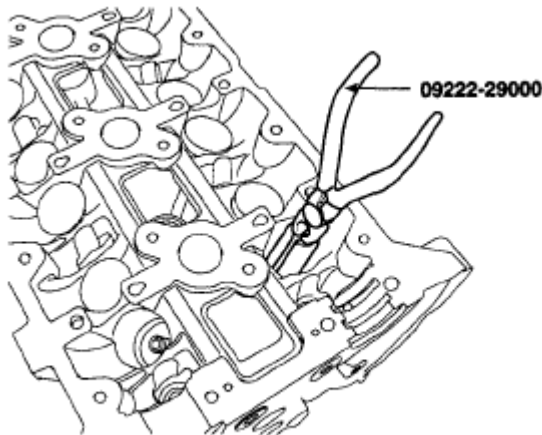
2. Remove valves.
  1. Using SST (09222-3K000, 09222-3C300), compress the valve spring and remove retainer lock.



KDRF201A

**Fig. 162: Compressing Valve Spring**  
Courtesy of HYUNDAI MOTOR CO.

2. Remove the spring retainer.
3. Remove the valve spring.
4. Remove the valve.
5. Using SST (09222-29000), remove the valve stem seal.

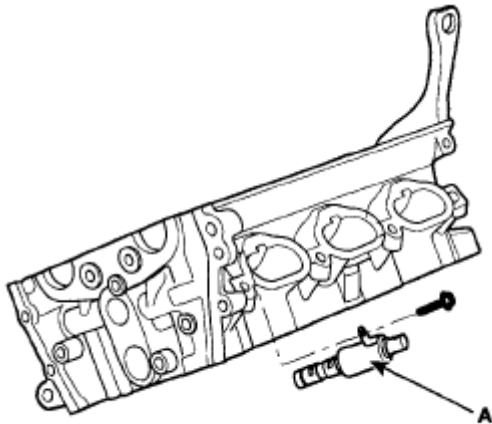


KDRF234A

**Fig. 163: Removing Valve Stem Seal Using Special Tool SST (09222-29000)**  
Courtesy of HYUNDAI MOTOR CO.

**NOTE:** Do not reuse old valve stem seals.

3. Remove OCV (A).



KDRF202A

**Fig. 164: Identifying OCV**  
Courtesy of HYUNDAI MOTOR CO.

## INSPECTION

### CYLINDER HEAD

1. Inspect for flatness.

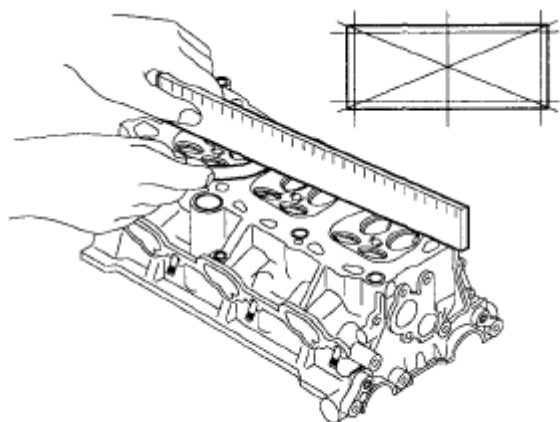
Using a precision straight edge and feeler gauge, measure the surface the contacting the cylinder block and the manifolds for warpage.

**Flatness of cylinder head gasket surface**

Standard: Less than 0.05 mm (0.002 in) [Less than 0.02 mm (0.0008 in)/150 x 150]

**Flatness of manifold gasket surface**

Standard: Less than 0.03 mm (0.001 in)/110 x 110



EDQF160A

**Fig. 165: Measuring Cylinder Head Surface**  
Courtesy of HYUNDAI MOTOR CO.

2. Inspect for cracks.

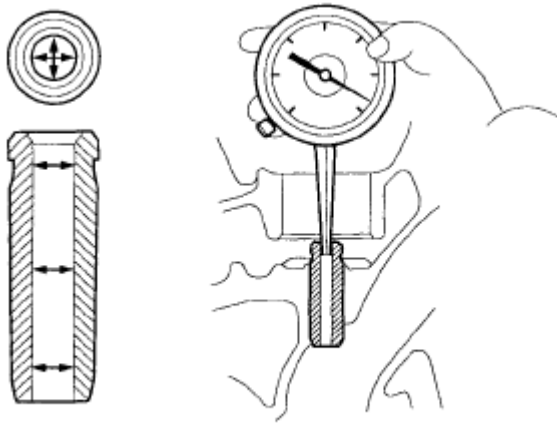
Check the combustion chamber, intake ports, exhaust ports and cylinder block surface for cracks. If cracked, replace the cylinder head.

**VALVE AND VALVE SPRING**

1. Inspect valve stems and valve guides.
  1. Using a caliper gauge, measure the inside diameter of the valve guide.

**Valve guide I.D.**

Intake / Exhaust: 5.500 ~ 5.512 mm (0.216 ~ 0.217 in)



KCRF203A

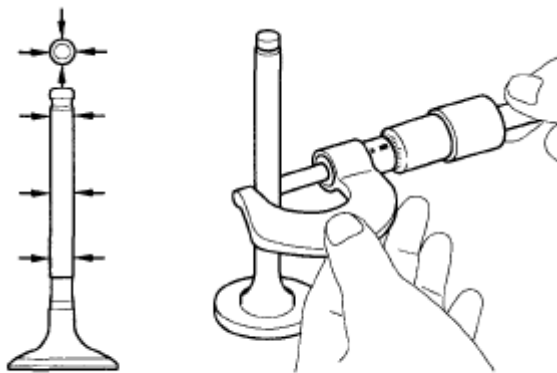
**Fig. 166: Measuring Inside Diameter Of Valve Guide**  
Courtesy of HYUNDAI MOTOR CO.

- Using a micrometer, measure the diameter of the valve stem.

**Valve stem O.D.**

Intake: 5.465 ~ 5.480 mm (0.2151 ~ 0.2157 in)

Exhaust: 5.458 ~ 5.470 mm (0.2149 ~ 0.2153 in)



KCRF227A

**Fig. 167: Measuring Diameter Of Valve Stem**  
Courtesy of HYUNDAI MOTOR CO.

- Subtract the valve stem diameter measurement from the valve guide inside diameter measurement.

**Valve stem-to-guide clearance**

[Standard]

Intake: 0.020 ~ 0.047 mm (0.0008 ~ 0.0018 in)

Exhaust: 0.030 ~ 0.054 mm (0.0012 ~ 0.0021 in)

[Limit]

Intake: 0.07 mm (0.0027 in)

Exhaust: 0.09 mm (0.0035 in)

2. Inspect valves.

1. Check the valve is ground to the correct valve face angle.
2. Check that the surface of the valve for wear. If the valve face is worn, replace the valve.
3. Check the valve head margin thickness.

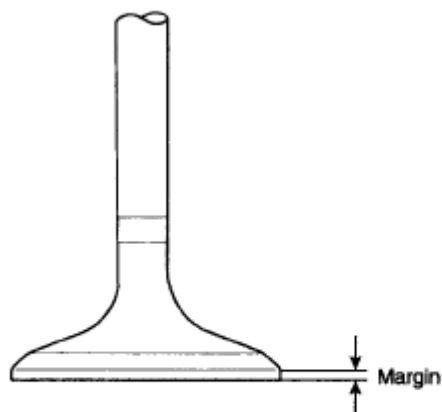
If the margin thickness is less than minimum, replace the valve.

**Margin**

[Standard]

Intake: 1.56 ~ 1.86 mm (0.06142 ~ 0.07323 in)

Exhaust: 1.73 ~ 2.03 mm (0.06811 ~ 0.07992 in)



ECK0221A

**Fig. 168: Identifying Valve Head Margin Thickness**  
Courtesy of HYUNDAI MOTOR CO.

4. Check the valve length.

**Length**

Intake: 105.27 mm (4.1445 in)

Exhaust: 105.50 mm (4.1535 in)

5. Check the surface of the valve stem tip for wear. If the valve stem tip is worn, replace the valve.
3. Inspect valve seats

Check the valve seat for evidence of overheating and improper contact with the valve face.

If the valve seat is worn, replace cylinder head.

Before reconditioning the seat, check the valve guide for wear. If the valve guide is worn, replace cylinder head. Recondition the valve seat with a valve seat grinder or cutter. The valve seat contact width should be within specifications and centered on the valve face.

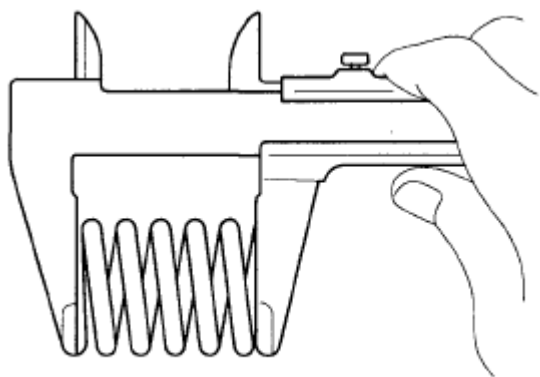
4. Inspect valve springs.
  1. Using a steel square, measure the out-of-square of the valve spring.
  2. Using a vernier calipers, measure the free length of the valve spring.

### Valve spring

[Standard]

Free height: 43.86 mm (1.7267 in)

Out-of-square: 1.5°



KCRF205A

**Fig. 169: Measuring Free Length Of Valve Spring**  
Courtesy of HYUNDAI MOTOR CO.

### MLA

1. Inspect MLA.

Using a micrometer, measure the MLA outside diameter.

**MLA O.D.**

Intake/Exhaust: 34.964 ~ 34.980 mm (1.3765 ~ 1.3771 in)

2. Using a caliper gauge, measure MLA tappet bore inner diameter of cylinder head.

**Tappet bore I.D.**

Intake/Exhaust: 35.000 ~ 35.025 mm (1.3779 ~ 1.3789 in)

3. Subtract MLA outside diameter measurement from tappet bore inside diameter measurement.

**MLA to tappet bore clearance**

[Standard]

Intake/Exhaust: 0.020 ~ 0.061 mm (0.0008 ~ 0.0024 in)

[Limit]

Intake/Exhaust: 0.07 mm (0.0027 in)

**CAMSHAFT**

1. Inspect cam lobes.

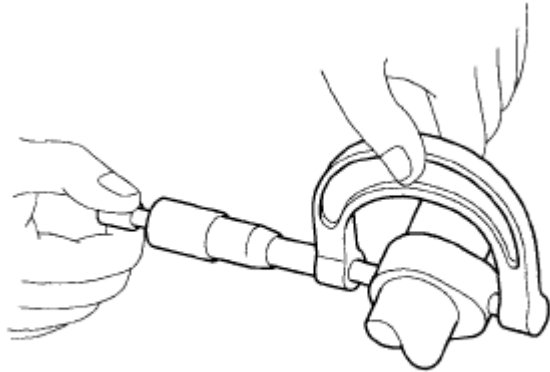
Using a micrometer, measure the cam lobe height.

**Cam height**

[Standard value]

Intake: 46.3 mm (1.8228 in)

Exhaust: 45.8 mm (1.8031 in)

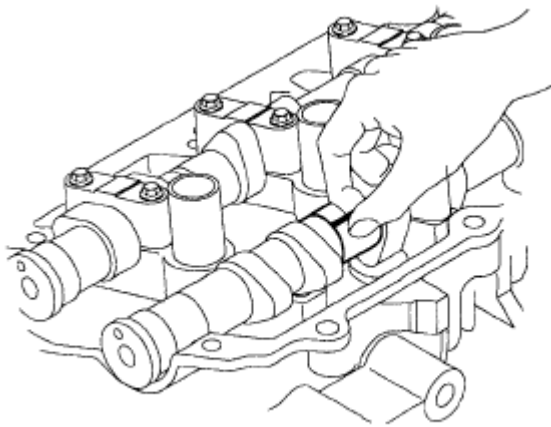


KCRF206A

**Fig. 170: Measuring Cam Lobe Height**  
 Courtesy of HYUNDAI MOTOR CO.

If the cam lobe height is less than standard, replace the camshaft.

2. Inspect camshaft journal clearance.
  1. Clean the bearing caps and camshaft journals.
  2. Place the camshafts on the cylinder head.
  3. Lay a strip of plastigage across each of the camshaft journal.



KCRF207A

**Fig. 171: Laying Strip Of Plastigage Of Camshaft Journal**  
 Courtesy of HYUNDAI MOTOR CO.

4. Install the bearing caps. (See **INSTALLATION**)

**CAUTION: Do not turn the camshaft.**

5. Remove the bearing caps.

6. Measure the plastigage at its widest point.

**Bearing oil clearance**

[Standard value]

Intake

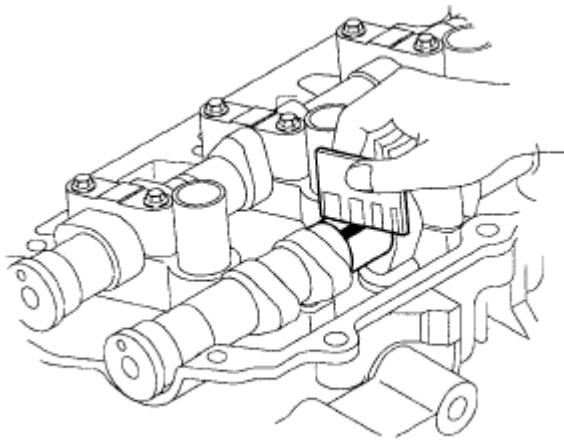
No. 1 journal: 0.020 ~ 0.057 mm (0.0008 ~ 0.0022 in)

No. 2,3,4 journal: 0.030 ~ 0.067 mm (0.0012 ~ 0.0026 in)

Exhaust

No. 1 journal: 0.020 ~ 0.057 mm (0.0008 ~ 0.0022 in)

No. 2,3,4,, journal: 0.030 ~ 0.067 mm (0.0012 ~ 0.0026 in)



KCRF208A

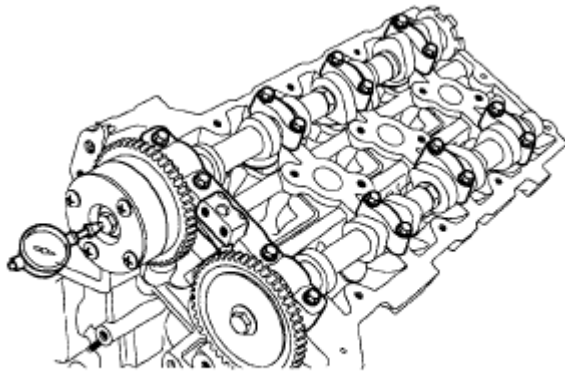
**Fig. 172: Measuring Plastigage Widest Point**  
Courtesy of HYUNDAI MOTOR CO.

If the oil clearance is greater than maximum, replace the camshaft. If necessary, replace cylinder head.

7. Completely remove the plastigage.
8. Remove the camshafts.
3. Inspect camshaft end play.
  1. Install the camshafts. (See **INSTALLATION**)
  2. Using a dial indicator, measure the end play while moving the camshaft back and forth.

**Camshaft end play**

[Standard value]: 0.056 ~ 0.064 mm (0.0022 ~ 0.0025 in)



KDRF196B

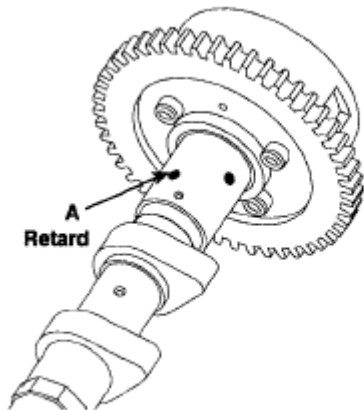
**Fig. 173: Measuring Camshaft End Play**  
 Courtesy of HYUNDAI MOTOR CO.

If the end play is greater than maximum, replace the camshaft. If necessary, replace cylinder head.

3. Remove the camshafts.

**CVVT ASSEMBLY**

1. Inspect CVVT assembly.
  1. Check that the CVVT assembly will not turn.
  2. Apply vinyl tape to the retard hole except the one indicated by the arrow in the illustration.



ECRF015A

**Fig. 174: Identifying Retard Hole**  
 Courtesy of HYUNDAI MOTOR CO.

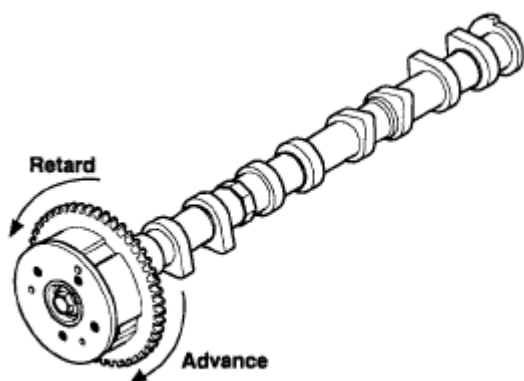
3. Wind tape around the tip of the air gun and apply air of approx. 150 kpa (1.5 kgf/cm<sup>2</sup> , 21 psi) to the port of the camshaft.

(Perform this order to release the lock pin for the maximum delay angle locking.)

**NOTE:** When the oil splashes, wipe it off with a shop rag.

4. Under the condition of (3), turn the CVVT assembly to the advance angle side (the arrow marked direction in the illustration) with your hand.

Depending on the air pressure, the CVVT assembly will turn to the advance side without applying force by hand. Also, under the condition that the pressure can be hardly applied because of the air leakage from the port, there may be the case that the lock pin could be hardly released.



ECRF016A

**Fig. 175: Turning CVVT Assembly**  
Courtesy of HYUNDAI MOTOR CO.

5. Except the position where the lock pin meets at the maximum delay angle, let the CVVT assembly turn back and forth and check the movable range and that there is no disturbance.

Standard: Movable smoothly in the range about 22.5°

6. Turn the CVVT assembly with your hand and lock it at the maximum delay angle position (counter clockwise).

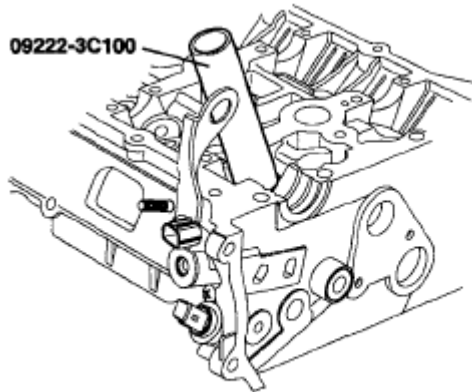
## REASSEMBLY

**NOTE:** Thoroughly clean all parts to be assembled.  
Before installing the parts, apply fresh engine oil to all sliding and rotating surfaces.  
Replace oil seals with new ones.

1. Install valves.
  1. Using SST (09222-3C100), push in a new oil seal.

**NOTE:** Do not reuse old valve stem seals.

**Incorrect installation of the seal could result in oil leakage past the valve guides.**



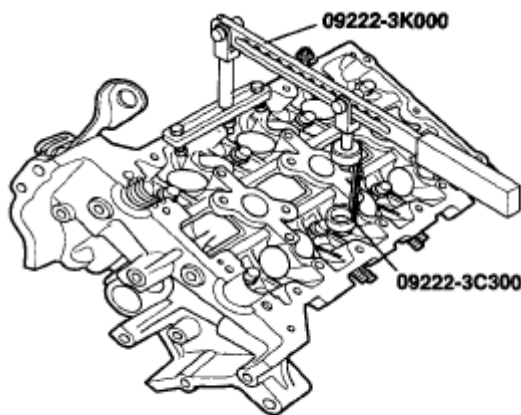
KCRF120B

**Fig. 176: Identifying SST (09222-3C100) On Oil Seal**  
 Courtesy of HYUNDAI MOTOR CO.

2. Install the valve, valve spring and spring retainer.

**NOTE:** Place valve springs so that the side coated with enamel faces toward the valve spring retainer and then installs the retainer.

3. Using the SST (09222-3K000, 09222-3C300), compress the spring and install the retainer locks. After installing the valves, ensure that the retainer locks are correctly in place before releasing the valve spring compressor.



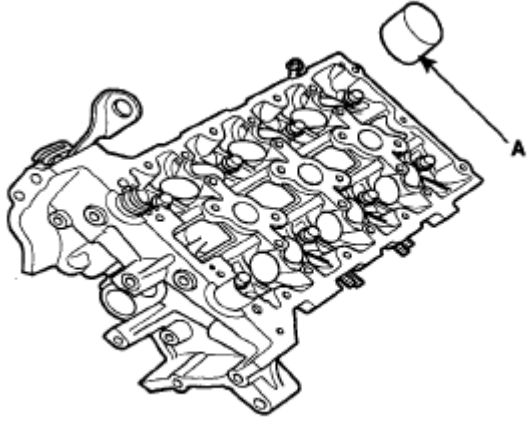
KDRF201A

**Fig. 177: Compressing Valve Spring Using Special Tool SST (09222-3K000, 09222-3C300)**  
 Courtesy of HYUNDAI MOTOR CO.

4. Lightly tap the end of each valve stem two or three times with the wooden handle of a hammer to ensure proper seating of the valve and retainer lock.

2. Install MLAs.

Check that the MLA rotates smoothly by hand.



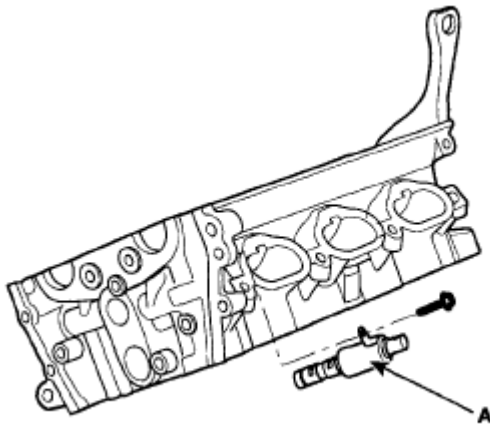
KDRF200A

**Fig. 178: Identifying MLAs**  
 Courtesy of HYUNDAI MOTOR CO.

**NOTE:** MLA can be reinstalled in its original position.

3. Install OCV (A).

**Tightening torque** 9.80 ~ 11.76 Nm (1.0 ~ 1.2 kgf.m, 7.23 ~ 8.68 lbf.ft)



KDRF202A

**Fig. 179: Identifying OCV**  
 Courtesy of HYUNDAI MOTOR CO.

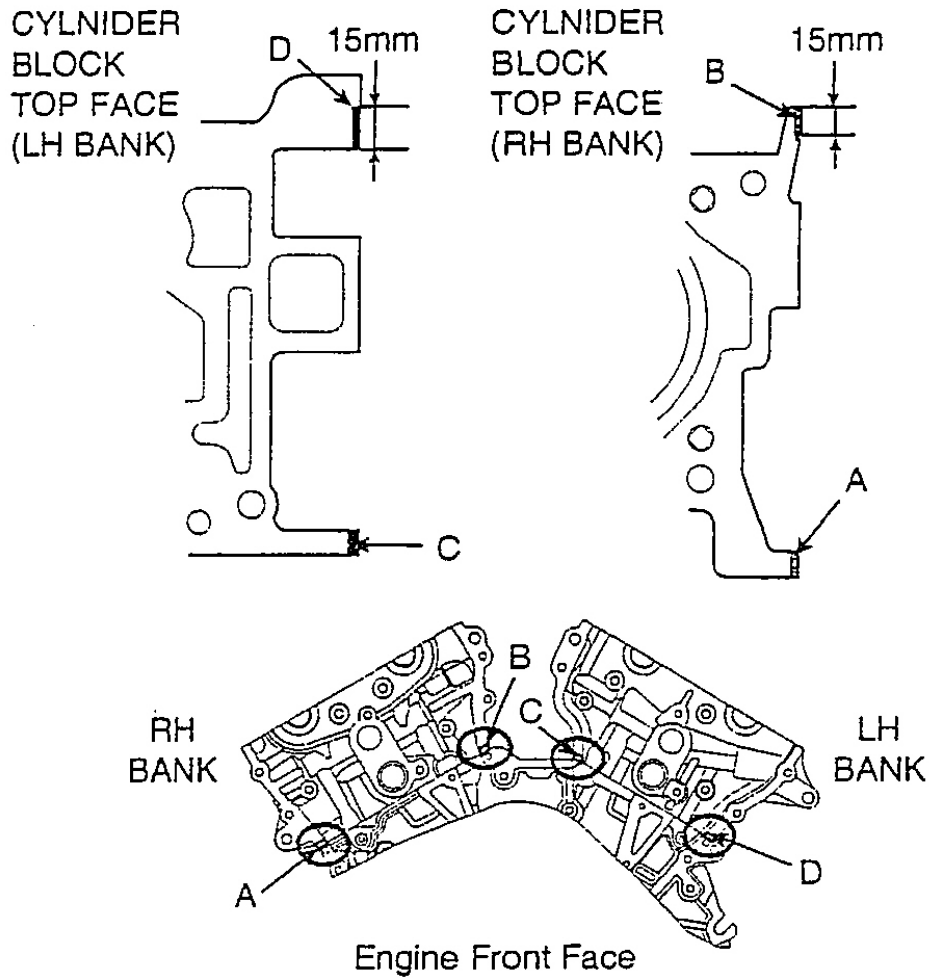
**NOTE:**

- To install OCV with gray colored connector into RH bank.
- To install OCV with black colored connector into LH bank.

- CAUTION:**
- Do not reuse the OCV when dropped.
  - Keep clean the OCV.
  - Do not hold the OCV sleeve during servicing.
  - When the OCV is installed on the engine, do not move the engine with holding the OCV yoke.

## INSTALLATION

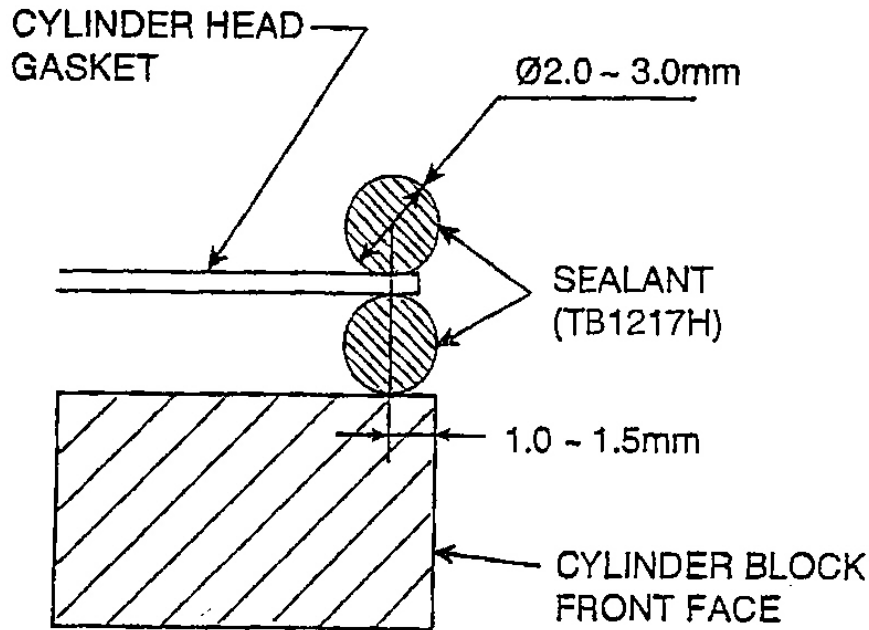
- NOTE:**
- Thoroughly clean all parts to be assembled.
  - Always use a new head and manifold gasket.
  - The cylinder head gasket is a metal gasket. Take care not to bend it.
  - Rotate the crankshaft, set the No. 1 piston at TDC. (See VALVE CLEARANCE INSPECTION AND ADJUSTMENT)
1. Install the cylinder head gasket on the cylinder block.
    - a. The sealant locations on cylinder head and cylinder block must be free of engine oil and ETC.
    - b. Apply sealant on cylinder block top face before assembling cylinder head gaskets. The part must be assembled within 5 minutes after sealant was applied.



ECBF017A

**Fig. 180: Identifying Sealant Locations On Cylinder Head And Cylinder Block**  
 Courtesy of HYUNDAI MOTOR CO.

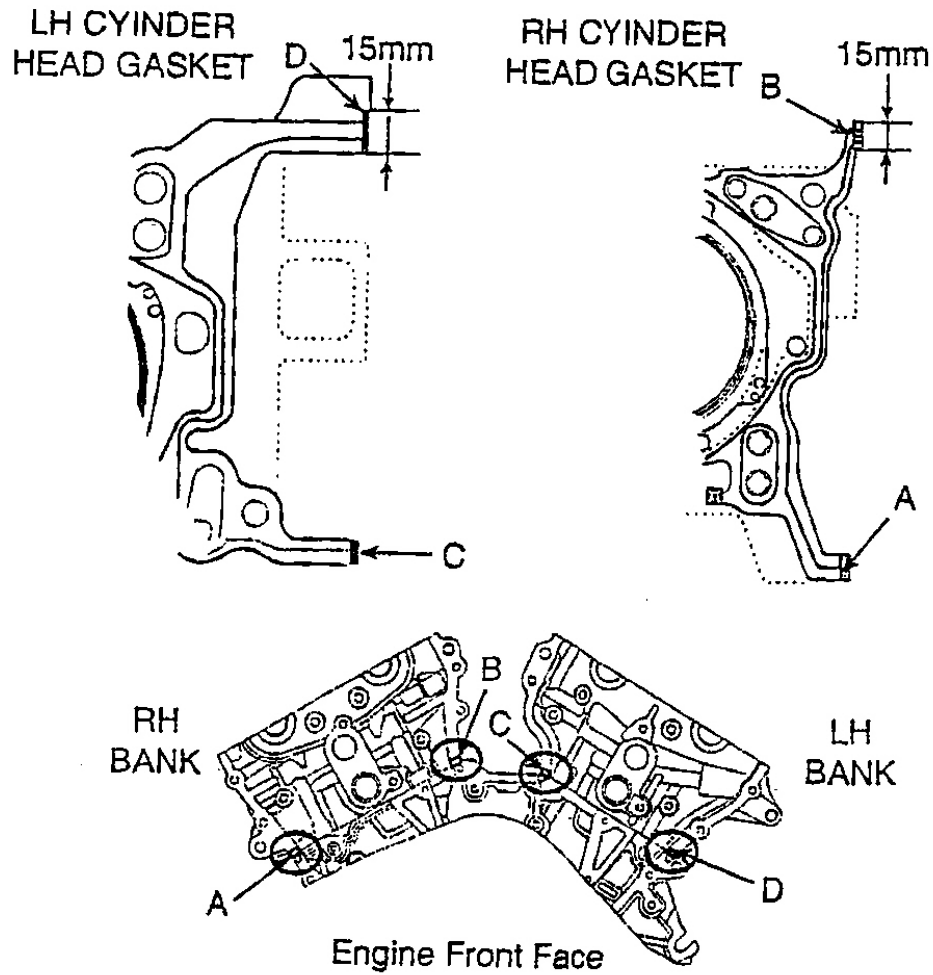
- NOTE:**
- Refer to below illustration to apply the sealant.
  - Bead width : 2.0-3.0 mm.
  - Sealant locations: 1.0-1.5 mm from block surface.
  - Recommended sealant: Liquid sealant TB1217H.



ECBF018A

**Fig. 181: Identifying Sealant Locations On Cylinder Head Gaskets & Cylinder Block**  
Courtesy of HYUNDAI MOTOR CO.

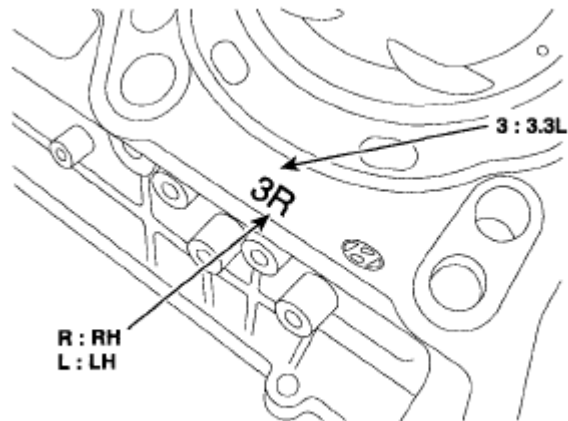
- c. Apply sealant on cylinder head gaskets after assembling cylinder head gaskets on cylinder block. The part must be assembled within 5 minutes after sealant was applied.



ECBF019A

**Fig. 182: Applying Sealant On Cylinder Head Gaskets**  
Courtesy of HYUNDAI MOTOR CO.

**NOTE:** Be careful of the installation direction.

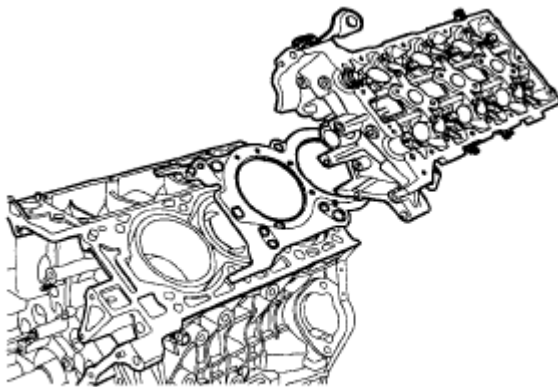


EDRF023A

**Fig. 183: Identifying Cylinder Head Marking 3R (RH Shown)  
Courtesy of HYUNDAI MOTOR CO.**

- d. Install the cylinder head

**NOTE:** Remove the extruded sealant after assembling cylinder heads



KDRF198A

**Fig. 184: Identifying Cylinder Head Gasket On Cylinder Block  
Courtesy of HYUNDAI MOTOR CO.**

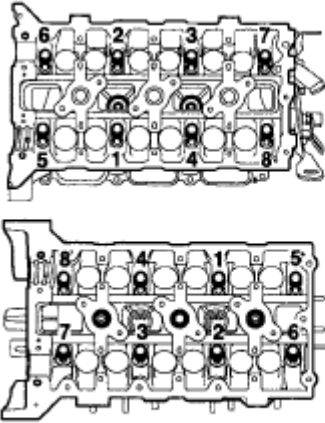
- 2. Place the cylinder head carefully in order not to damage the gasket with the bottom part of the end.
- 3. Install cylinder head bolts.
  - 1. Do not apply engine oil on the threads and under the heads of the cylinder head bolts.
  - 2. Using SST (09221-4A000), install and tighten the cylinder head bolts and plate washers, in several passes, in the sequence shown.

**Tightening torque**

39.2 Nm (4.0 kgf.m, 28.93 lbf.ft) + 120° + 90°

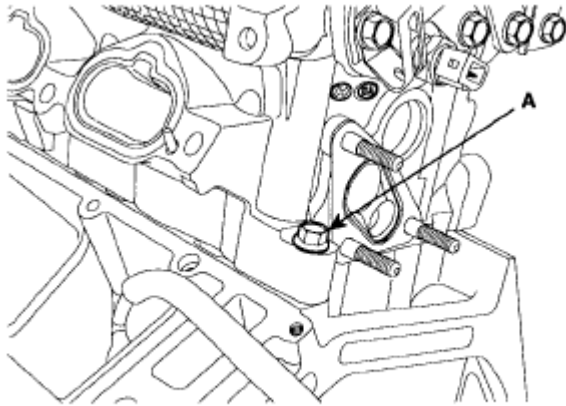
18.62 ~ 23.52 Nm (1.9 ~ 2.4 kgf.m, 13.74 ~ 17.36 lbf.ft) (A)

**NOTE:** Always use new cylinder head bolt.



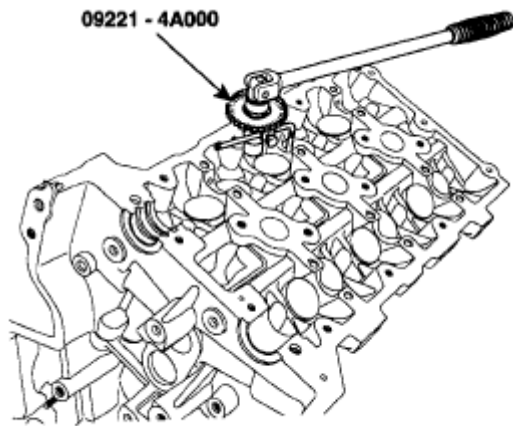
KDRF199B

**Fig. 185: Identifying Tightening Sequence Of Cylinder Head Bolts**  
Courtesy of HYUNDAI MOTOR CO.



KDRF204A

**Fig. 186: Identifying Cylinder Head Bolt**  
Courtesy of HYUNDAI MOTOR CO.



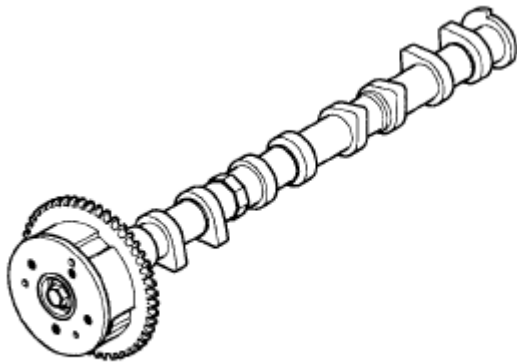
KDRF223A

**Fig. 187: Installing Cylinder Head Using Special Tool SST (09221-4A000)**  
Courtesy of HYUNDAI MOTOR CO.

4. Install the CVVT and camshaft sprocket.

**Tightening torque**

64.68 ~ 76.44 Nm (6.6 ~ 7.8 kgf.m, 47.74 ~ 56.4 lbf.ft)



KCRF122A

**Fig. 188: Identifying CVVT And Camshaft Sprocket**  
Courtesy of HYUNDAI MOTOR CO.

**NOTE:**

- Install camshaft-inlet to dowel pin of CVVT assembly.

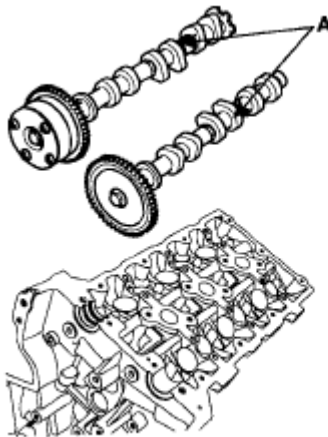
At this time, attend not to be installed to oil hole of camshaft-inlet.

- Hold the hexagonal head wrench portion of the camshaft with a vise, and install the bolt and CVVT assembly.
- Do not rotate CVVT assembly when camshaft is installed to dowel pin of CVVT assembly.

5. Install camshafts (A).

**NOTE:**

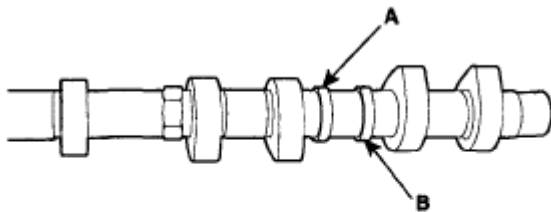
- Apply a light coat of engine oil on camshaft journals.
- Assemble the key groove of camshaft rear side to the same level of head top surface.
- Be careful the right, left bank, intake, exhaust side before assembling.



KDRF197A

**Fig. 189: Identifying Camshafts**  
 Courtesy of HYUNDAI MOTOR CO.

**Intake Camshaft**



KDRF226A

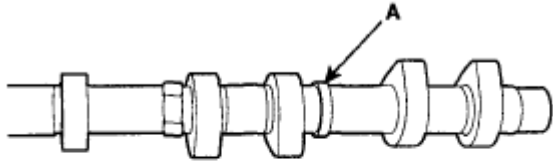
**Fig. 190: Identifying Intake Camshaft**  
 Courtesy of HYUNDAI MOTOR CO.

**INTAKE CAMSHAFT DIAMETER SPECIFICATIONS**

	LH	RH
3.3L	A: 27mm (1.0630 in)	A: 30 mm (1.1811 in)

	B: 27 mm (1.0630 in)	B: 30 mm (1.1811 in)
--	----------------------	----------------------

**Exhaust Camshaft**



KDRF227A

**Fig. 191: Identifying Exhaust Camshaft**  
Courtesy of HYUNDAI MOTOR CO.

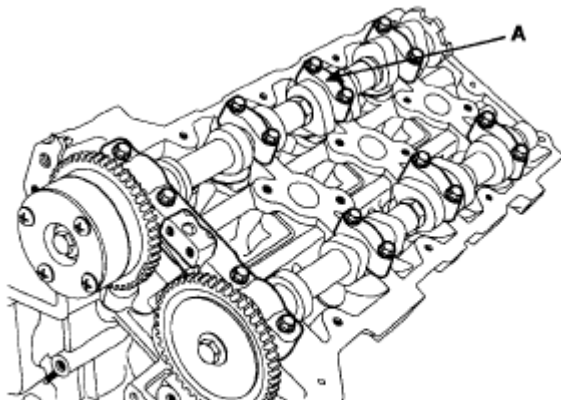
**EXHAUST CAMSHAFT DIAMETER SPECIFICATIONS**

	LH	RH
3.3L	A: 27 mm (1.0630 in)	A: 30 mm (1.1811 in)

- 6. Install camshaft bearing caps.

**Tightening torque**

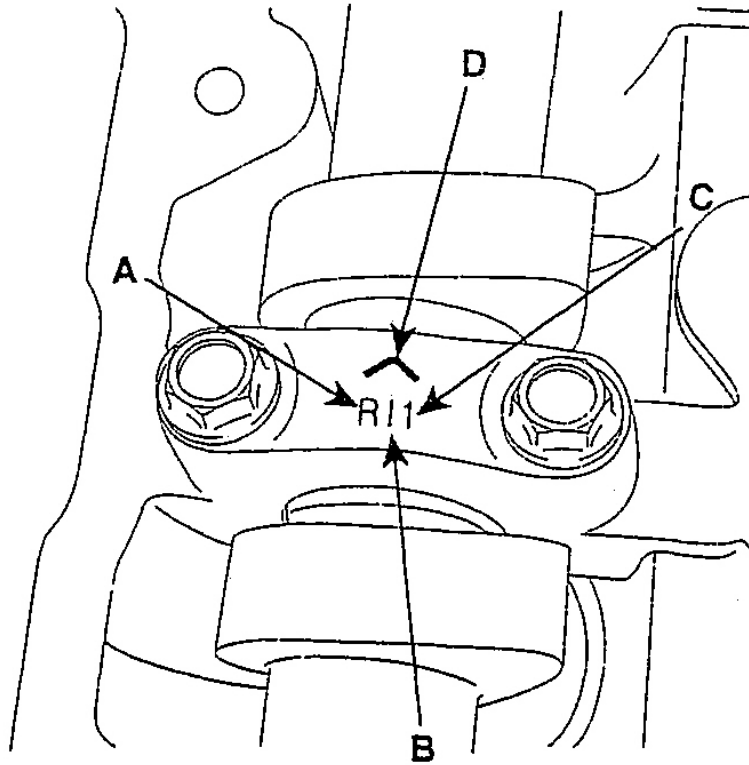
9.80 ~ 11.76 Nm (1.0 ~ 1.2 kgf.m, 7.23 ~ 8.68 lbf.ft)



KDRF196A

**Fig. 192: Identifying Camshaft Bearing Caps**  
Courtesy of HYUNDAI MOTOR CO.

**NOTE:** Be careful the right, left bank, intake, exhaust side before assembling.



ECBF036A

**Fig. 193: Identifying Mark On Camshaft Bearing Caps**  
Courtesy of HYUNDAI MOTOR CO.

A: L (LH), R (RH)

B: (Intake), None (Exhaust)

C: Journal number

D: Front mark

**CAUTION:** Rotate the crankshaft not to contact the valves to the pistons by making the pistons below 10mm (0.3937 in) from the top of cylinder block.

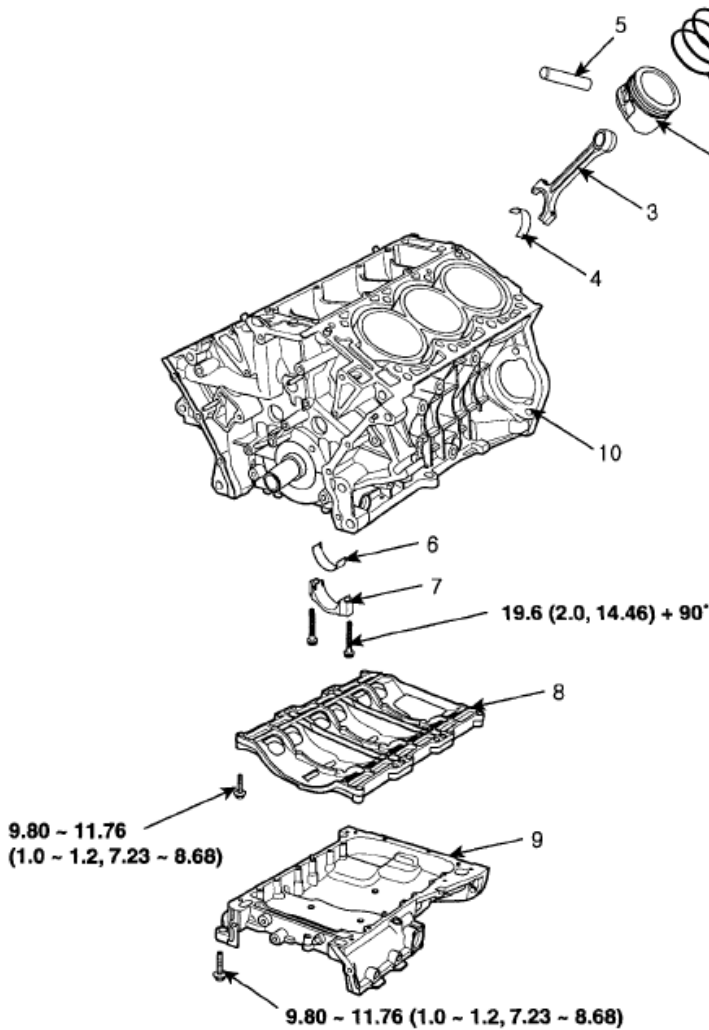
7. Install water temperature control assembly. (See WATER TEMPERATURE CONTROL)

**ASSEMBLY)**

8. Install timing chain (See **INSTALLATION**)
9. Check and adjust valve clearance. (See **VALVE CLEARANCE INSPECTION AND ADJUSTMENT**)
10. Install the exhaust manifold. (See **EXHAUST MANIFOLD**)
11. Install the intake manifold. (See **INTAKE MANIFOLD**)

**ENGINE BLOCK**

**COMPONENTS**



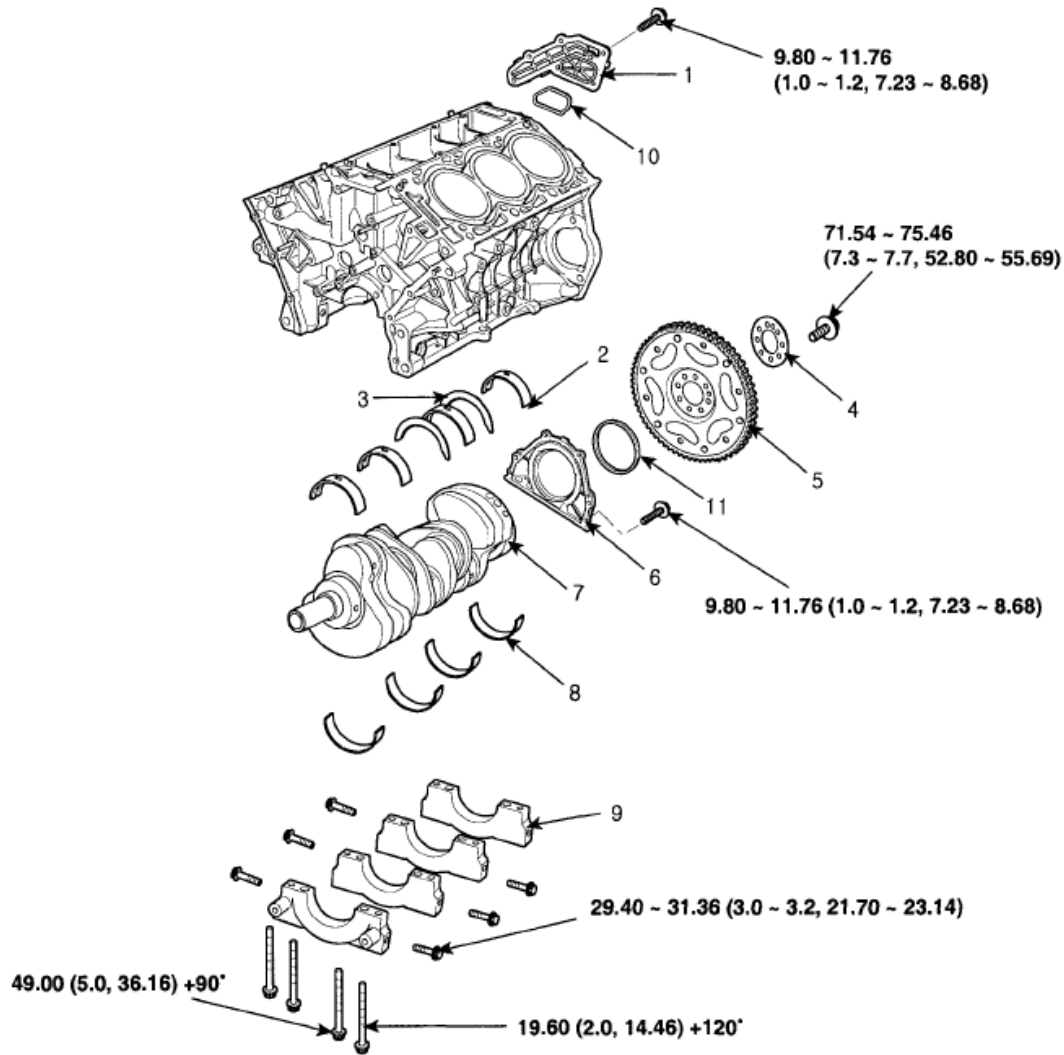
**TORQUE : N.m (kgf.m, lbf.ft)**

- |                                 |                                 |
|---------------------------------|---------------------------------|
| 1. Piston ring                  | 6. Connecting rod lower bearing |
| 2. Piston                       | 7. Connecting rod bearing cap   |
| 3. Connecting rod               | 8. Baffle plate                 |
| 4. Connecting rod upper bearing | 9. Upper oil pan                |
| 5. Piston pin                   | 10. Cylinder block              |

EDRF005A

**Fig. 194: Exploded View Of Engine Block Components With Torque Specifications (1 Of 2)**

Courtesy of HYUNDAI MOTOR CO.



**TORQUE : N.m (kgf.m, lbf.ft)**

- |                             |                             |
|-----------------------------|-----------------------------|
| 1. Oil drain cover          | 6. Rear oil seal case       |
| 2. Crankshaft upper bearing | 7. Crankshaft               |
| 3. Thrust bearing           | 8. Crankshaft lower bearing |
| 4. Plate adapter            | 9. Main bearing cap         |
| 5. Drive plate              | 10. Oil drain cover gasket  |
|                             | 11. Rear oil seal           |

EDRF006A

**Fig. 195: Exploded View Of Engine Block Components With Torque Specifications (2 Of 2)**  
 Courtesy of HYUNDAI MOTOR CO.

**REMOVAL**

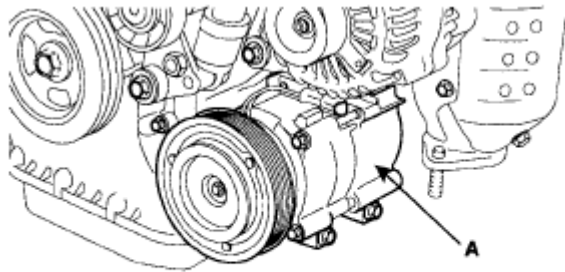
- CAUTION:**
- Use fender covers to avoid damaging painted surfaces.
  - To avoid damage, unplug the wiring connectors carefully while

holding the connector portion.

**NOTE:**

- Mark all wiring and hoses to avoid misconnection.
- Inspection the timing belt before removing the cylinder head.
- Turn the crankshaft pulley so that the No. 1 piston is at top dead center. (See VALVE CLEARANCE INSPECTION AND ADJUSTMENT)

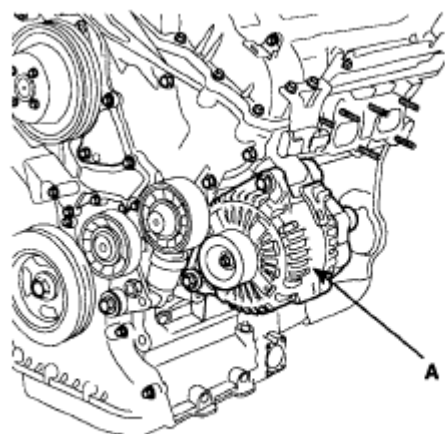
1. Remove exhaust manifold. (See EXHAUST MANIFOLD)
2. Remove intake manifold. (See REMOVAL)
3. Remove timing chain. (See REMOVAL)
4. Remove water temperature control assembly. (See WATER TEMPERATURE CONTROL ASSEMBLY)
5. Remove cylinder head. (See REMOVAL)
6. Remove oil pump. (See REMOVAL)
7. Remove oil filter assembly. (See OIL FILTER ASSEMBLY)
8. Remove A/C compressor (A) from engine.



KDRF103A

**Fig. 196: Identifying A/C Compressor**  
Courtesy of HYUNDAI MOTOR CO.

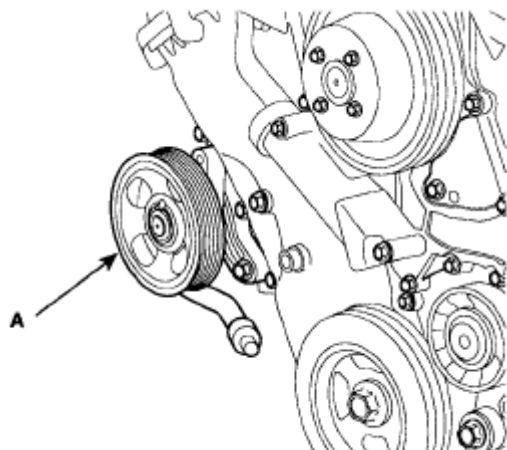
9. Remove alternator (A) from engine.



KDRF104A

**Fig. 197: Identifying Alternator**  
Courtesy of HYUNDAI MOTOR CO.

10. Remove power steering pump (A) from engine.

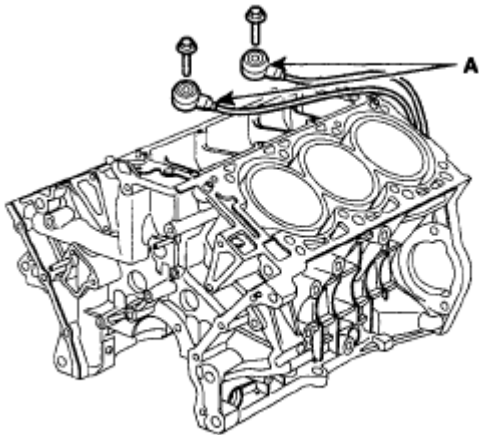


KDRF102A

**Fig. 198: Identifying Power Steering Pump**  
Courtesy of HYUNDAI MOTOR CO.

## DISASSEMBLY

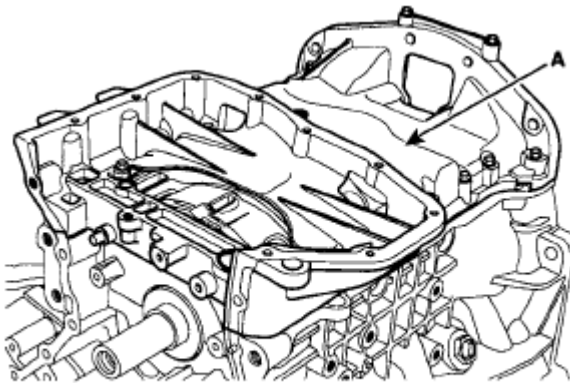
1. Remove drive plate.
2. Remove knock sensor (A).



KDRF205A

**Fig. 199: Identifying Knock Sensor**  
Courtesy of HYUNDAI MOTOR CO.

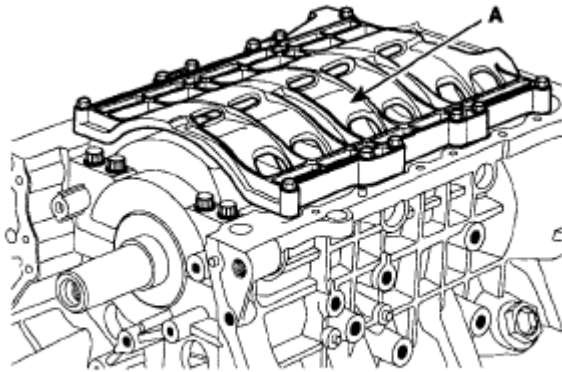
3. Remove upper oil pan (A).



KDRF206A

**Fig. 200: Identifying Upper Oil Pan**  
Courtesy of HYUNDAI MOTOR CO.

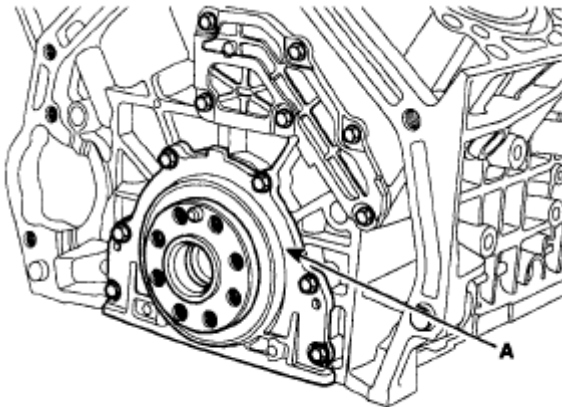
4. Remove baffle plate (A).



KDRF207A

**Fig. 201: Identifying Baffle Plate**  
Courtesy of HYUNDAI MOTOR CO.

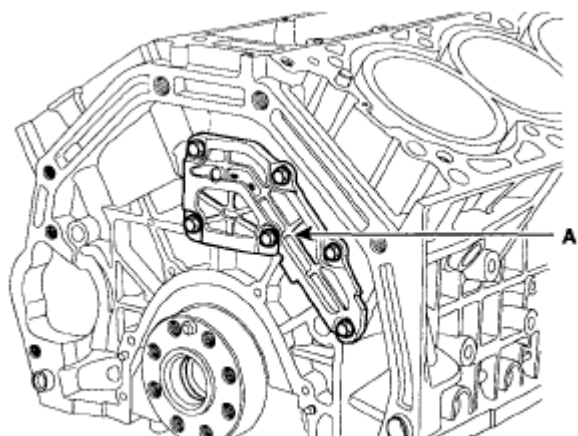
5. Remove rear oil seal case (A).



KDRF208A

**Fig. 202: Identifying Rear Oil Seal Case**  
Courtesy of HYUNDAI MOTOR CO.

6. Remove oil drain cover (A).



KDRF209A

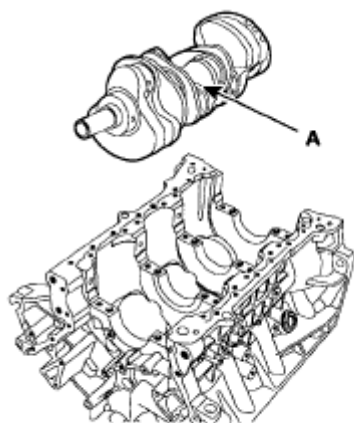
**Fig. 203: Identifying Oil Drain Cover**  
 Courtesy of HYUNDAI MOTOR CO.

7. Check the connecting rod end play. (See CONNECTING ROD AND CRANKSHAFT)
8. Check the connecting rod oil clearance. (See CONNECTING ROD AND CRANKSHAFT)
9. Remove piston and connecting rod assemblies.
  1. Using a ridge reamer, remove all the carbon from the top of the cylinder.
  2. Push the piston, connecting rod assembly and upper bearing through the top of the cylinder block.

**NOTE:**

- Keep the bearings, connecting rod and cap together.
- Arrange the piston and connecting rod assemblies in the correct order.

10. Remove crankshaft main bearing cap and check oil clearance. (See CONNECTING ROD AND CRANKSHAFT)
11. Check the crankshaft end play. (See CONNECTING ROD AND CRANKSHAFT)
12. Lift the crankshaft (A) out of engine, being careful not to damage journals.



KDRF210A

**Fig. 204: Identifying Crankshaft**  
 Courtesy of HYUNDAI MOTOR CO.

**NOTE:** Arrange the main bearings and thrust bearings in the correct order.

13. Check fit between piston and piston pin.

Try to move the piston back and forth on the piston pin. If any movement is felt, replace piston and piston pin as a set.

14. Remove piston rings.
1. Using a piston ring expander, remove the 2 compression rings.
  2. Remove 2 side rails and the spacer by hand.

**NOTE:** Arrange the piston rings in the correct order only.

15. Disconnect connecting rod from piston.

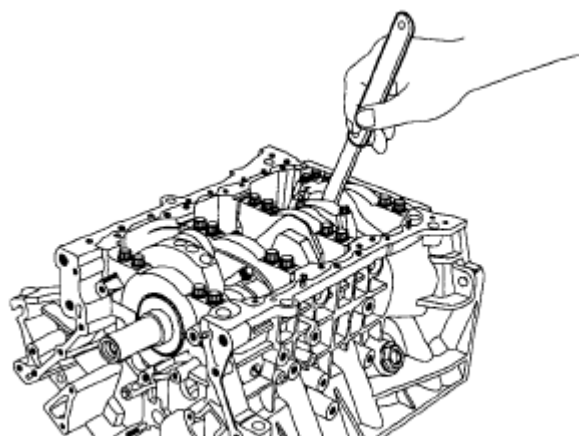
## INSPECTION

### CONNECTING ROD AND CRANKSHAFT

1. Check the connecting rod end play.

Using a feeler gauge, measure the end play while moving the connecting rod back and forth.

Standard end play: 0.1~ 0.25 mm (0.004 ~ 0.010 in)



KDRF211A

**Fig. 205: Measuring Connecting Rod End Play**  
Courtesy of HYUNDAI MOTOR CO.

- If out-of-tolerance, install a new connecting rod.
  - If still out-of-tolerance, replace the crankshaft.
2. Check the connecting rod bearing oil clearance.
    1. Check the matchmarks on the connecting rod and cap are aligned to ensure correct reassembly.
    2. Remove 2 connecting rod cap bolts.
    3. Remove the connecting rod cap and bearing half.
    4. Clean the crank pin and bearing.
    5. Place plastigage across the crank pin.
    6. Reinstall the bearing half and cap, and torque the bolts.

**Tightening torque**

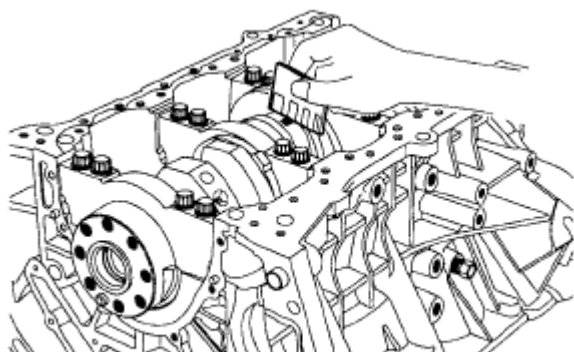
19.6 Nm (2.0 kgf.m, 14.46 lbf.ft) + 90°

**NOTE: Do not turn the crankshaft.**

7. Remove 2 bolts, connecting rod cap and bearing-half.
8. Measure the plastigage at its widest point.

**Standard oil clearance**

0.030 ~ 0.048 mm (0.0012 ~ 0.0019 in)



KDRF212A

**Fig. 206: Measuring Plastigage Widest Point**  
Courtesy of HYUNDAI MOTOR CO.

9. If the plastigage measures too wide or too narrow, remove the upper half of the bearing, install a new, complete bearing with the same color mark (select the color as shown in the next column), and recheck the clearance.

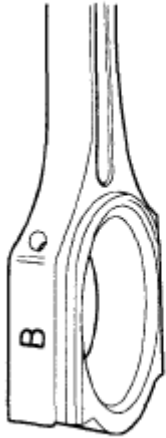
**CAUTION: Do not file, shim, or scrape the bearings or the caps to adjust clearance.**

10. If the plastigage shows the clearance is still incorrect, try the next larger or smaller bearing (the color listed above or below that one), and check clearance again.

**NOTE: If the proper clearance cannot be obtained by using the appropriate larger or smaller bearings, replace the crankshaft and start over.**

**CAUTION: If the marks are indecipherable because of an accumulation of dirt and dust, do not scrub them with a wire brush or scraper. Clean them only with solvent or detergent.**

#### CONNECTING ROD MARK LOCATION



EDQF196A

**Fig. 207: Identifying Connecting Rod Mark Location**  
 Courtesy of HYUNDAI MOTOR CO.

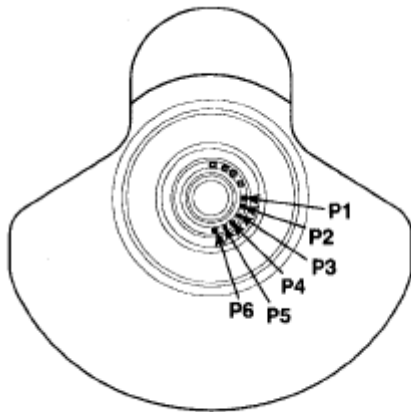
**DISCRIMINATION OF CONNECTING ROD**

**CONNECTING ROD INSIDE DIAMETER SPECIFICATIONS**

CLASS	MARK	INSIDE DIAMETER
0	a	58.000 ~ 58.006 mm (2.2834 ~ 2.2837 in)
1	b	58.006 ~ 58.012 mm (2.2837 ~ 2.2839 in)
2	c	58.012 ~ 58.018 mm (2.2839 ~ 2.2842 in)

**CRANKSHAFT PIN MARK LOCATION**

**DISCRIMINATION OF CRANKSHAFT**



ECBF037A

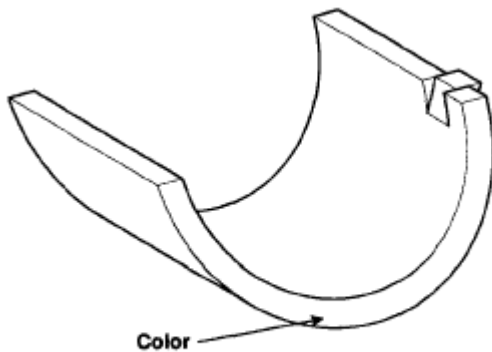
**Fig. 208: Identifying Crankshaft Pin Mark Locations**  
 Courtesy of HYUNDAI MOTOR CO.

**DISCRIMINATION OF CRANKSHAFT**

**CRANKSHAFT OUTSIDE DIAMETER OF PIN SPECIFICATIONS**

CLSASS	MARK	OUTSIDE DIAMETER OF PIN
I	A	54.966 ~ 54.972 mm (2.1640 ~ 2.1642 in)
II	B	54.960 ~ 54.966 mm (2.1638 ~ 2.1640 in)
III	C	54.954 ~ 54.960 mm (2.1635 ~ 2.1638 in)

**PLACE OF IDENTIFICATION MARK (CONNECTING ROD BEARING)**



ECRF021A

**Fig. 209: Identifying Connecting Rod Bearing Mark Location**  
 Courtesy of HYUNDAI MOTOR CO.

**DISCRIMINATION OF CONNECTING ROD BEARING**

**CONNECTING ROD BEARING THICKNESS SPECIFICATIONS**

CLASS	MARK	THICKNESS OF BEARING
E	BLUE	1.514 ~ 1.517 mm (0.0596 ~ 0.0597 in)
D	BLACK	1.511 ~ 1.514 mm (0.0595 ~ 0.0596 in)
C	NONE	1.508 ~ 1.511 mm (0.0594 ~ 0.0595 in)
B	GREEN	1.505 ~ 1.508 mm (0.0593 ~ 0.0594 in)
A	YELLOW	1.502 ~ 1.505 mm (0.0591 ~ 0.0593 in)

11. Selection

**CONNECTING ROD IDENTIFICATION MARK REFERENCE**

		CONNECTING ROD IDENTIFICATION MARK		
		0(a)	1(b)	2(c)
CRANKSHAFT IDENTIFICATION MARK	I (A)	A (YELLOW)	B (GREEN)	C (NONE)
	II (B)	B (GREEN)	C (NONE)	D (BLACK)
	III(C)	C (NONE)	D (BLACK)	E (BLUE)

3. Check the crankshaft bearing oil clearance.

1. To check main bearing-to-journal oil clearance, remove the main bearing caps and bearing halves.
2. Clean each main journal and bearing half with a clean shop towel.
3. Place one strip of plastigage across each main journal.
4. Reinstall the bearings and caps, then torque the bolts.

**Tightening torque**

49.00 Nm (5.0 kgf.m, 36.16 lbf.ft) + 90°

19.60 Nm (2.0 kgf.m, 14.46 lbf.ft) + 120°

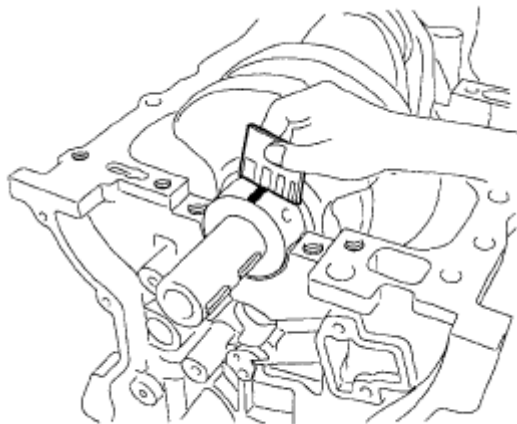
29.40 ~ 31.36 Nm (3.0 ~ 3.2 kgf.m, 21.70 ~ 23.14 lbf.ft)

**NOTE: Do not turn the crankshaft.**

- Remove the cap and bearing again, and measure the widest part of the plastigage.

Standard oil clearance

0.022 ~ 0.040 mm (0.0009 ~ 0.0016 in)



KCRF170A

**Fig. 210: Measuring Widest Part Of Plastigage**  
Courtesy of HYUNDAI MOTOR CO.

- If the plastigage measures too wide or too narrow, remove the upper half of the bearing, install a new, complete bearing with the same color mark (select the color as shown in the next column), and recheck the clearance.

**CAUTION: Do not file, shim, or scrape the bearings or the caps to adjust clearance.**

- If the plastigage shows the clearance is still incorrect, try the next larger or smaller bearing (the color listed above or below that one), and check clearance again.

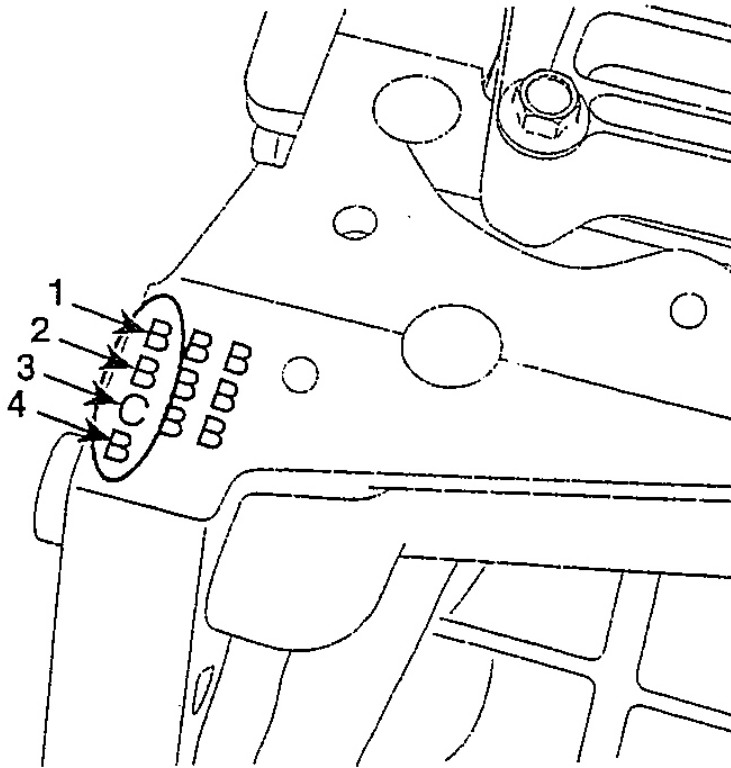
**NOTE:** If the proper clearance cannot be obtained by using the appropriate larger or smaller bearings, replace the crankshaft and start over.

**CAUTION: If the marks are indecipherable because of an accumulation of dirt and dust, do not scrub them with a wire brush or scraper. Clean them only with solvent or detergent.**

#### Crankshaft bore mark location

Letters have been stamped on the block as a mark for the size of each of the 5 main journal bores.

Use them, and the numbers or bar stamped on the crank (marks for main journal size), to choose the correct bearings.



ECBF038A

**Fig. 211: Identifying Crankshaft Bore Mark Location**  
 Courtesy of HYUNDAI MOTOR CO.

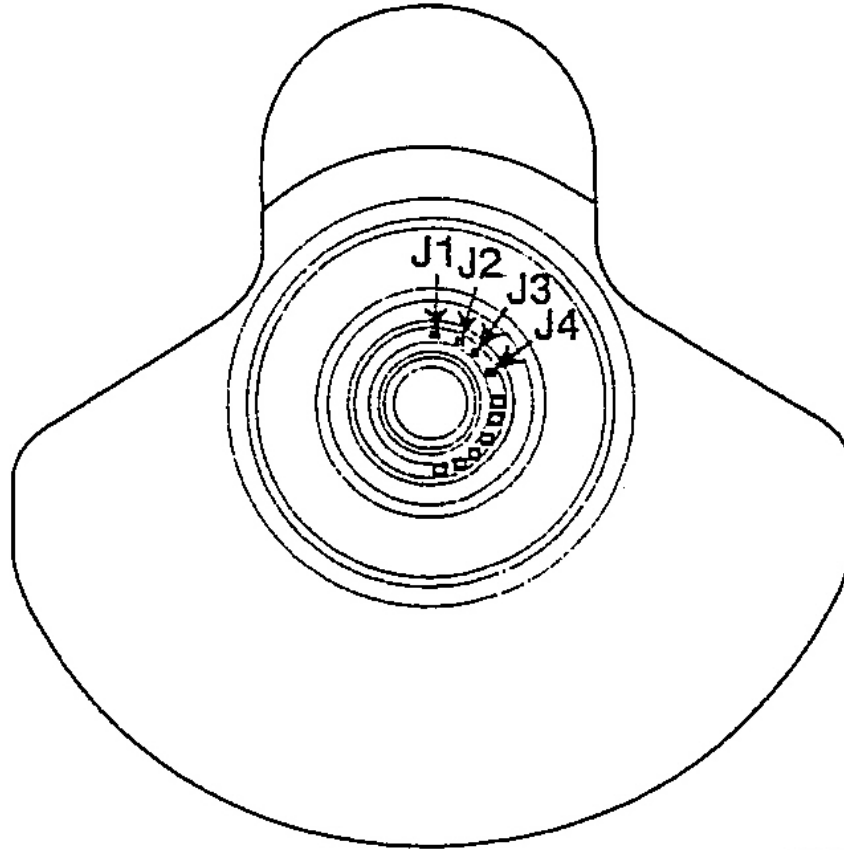
**DISCRIMINATION OF CYLINDER BLOCK**

**CYLINDER BLOCK INSIDE DIAMETER SPECIFICATIONS**

CALSS	MARK	INSIDE DIAMETER
a	A	73.500 ~ 73.506 mm (2.8937 ~ 2.8939 in)
b	B	73.506 ~ 73.512 mm (2.8939 ~ 2.8942 in)
c	C	73.512 ~ 73.518 mm (2.8942 ~ 2.8944 in)

**CRANKSHAFT JOURNAL MARK LOCATION**

**DISCRIMINATION OF CRANKSHAFT**



EC8F039A

**Fig. 212: Identifying Crankshaft Journal Mark Location**  
 Courtesy of HYUNDAI MOTOR CO.

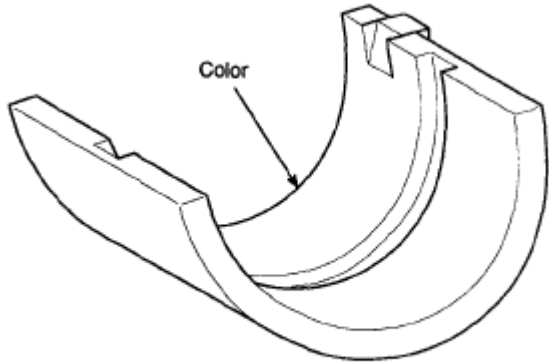
**DISCRIMINATION OF CRANKSHAFT**

**CRANKSHAFT OUTSIDE DIAMETER OF JOURNAL SPECIFICATIONS**

CLASS	MARK	OUTSIDE DIAMETER OF JOURNAL
I	A	68.954 ~ 68.960 mm (2.7147~2.7150 in)
II	B	68.948 ~ 68.954 mm (2.7145~2.7147 in)

III	C	68.942 ~ 68.948 mm (2.7142~2.7145 in)
-----	---	---

**PLACE OF IDENTIFICATION MARK (CRANKSHAFT BEARING)**



ECRF022A

**Fig. 213: Identifying Crankshaft Bearing Mark Location**  
Courtesy of HYUNDAI MOTOR CO.

**DISCRIMINATION OF CRANKSHAFT BEARING**

**CRANKSHAFT BEARING THICKNESS SPECIFICATIONS**

CLASS	MARK	THICKNESS OF BEARING
E	BLUE	2.277 ~ 2.280 mm (0.0896 ~ 0.0897 in)
D	BLACK	2.274 ~ 2.277 mm (0.0895 ~ 0.0896 in)
C	NONE	2.271 ~ 2.274 mm (0.0894 ~ 0.0895 in)
B	GREEN	2.268 ~ 2.271 mm (0.0893 ~ 0.0894 in)
A	YELLOW	2.265 ~ 2.268 mm (0.0892 ~ 0.0893 in)

**SELECTION**

**CRANKSHAFT BORE IDENTIFICATION MARK REFERENCE**

		CRANKSHAFT BORE IDENTIFICATION MARK		
		a(A)	b(B)	C(C)
CRANKSHAFT IDENTIFICATION	I (A)	A (YELLOW)	B (GREEN)	C (NONE)
	II (B)	B (GREEN)	C (NONE)	D (BLACK)

MARK

III(C)

C (NONE)

D (BLACK)

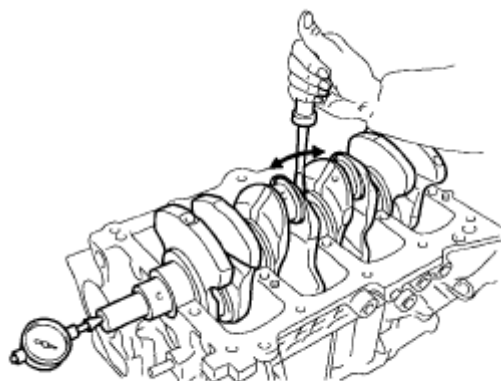
E (BLUE)

#### 4. Check crankshaft end play.

Using a dial Indicator, measure the thrust clearance while prying the crankshaft back and forth with a screwdriver.

Standard end play

0.10 ~ 0.28 mm (0.0039 ~ 0.0110 in)



ECKD001B

**Fig. 214: Measuring Crankshaft End Play**  
Courtesy of HYUNDAI MOTOR CO.

If the end play is greater than maximum, replace the thrust bearings as a set.

Thrust bearing thickness

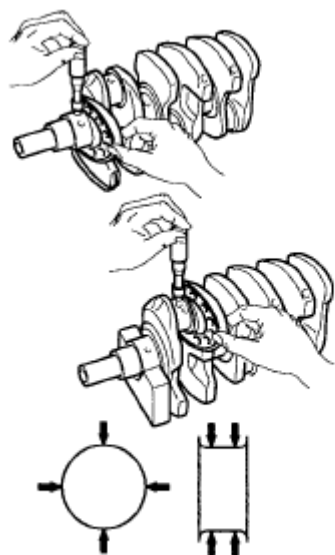
2.41 ~ 2.45 mm (0.0949 ~ 0.0964 in)

#### 5. Inspect main journals and crank pins

Using a micrometer, measure the diameter of each main journal and crank pin.

Main journal diameter: 68.942 ~ 68.960 mm (2.7142 ~ 2.7149 in)

Crank pin diameter: 54.954 ~ 54.972 mm (2.1635 ~ 2.1642 in)



ECKD001E

**Fig. 215: Measuring Diameter Of Main Journal And Crank Pin**  
 Courtesy of HYUNDAI MOTOR CO.

### CONNECTING RODS

1. When reinstalling, make sure that cylinder numbers put on the connecting rod and cap at disassembly match. When a new connecting rod is installed, make sure that the notches for holding the bearing in place are on the same side.
2. Replace the connecting rod if it is damaged on the thrust faces at either end. Also if step wear or a severely rough surface of the inside diameter of the small end is apparent, the rod must be replaced as well.
3. Using a connecting rod aligning tool, check the rod for bend and twist. If the measured value is close to the repair limit, correct the rod by a press. Any connecting rod that has been severely bent or distorted should be replaced.

Allowable bend of connecting rod:

0.05 mm / 100 mm (0.0020 in./3.94 in) or less

Allowable twist of connecting rod:

0.1 mm / 100 mm (0.0039 in./3.94 in) or less

### CYLINDER BLOCK

1. Remove gasket material.

Using a gasket scraper, remove all the gasket material from the top surface of the cylinder block.

2. Clean cylinder block

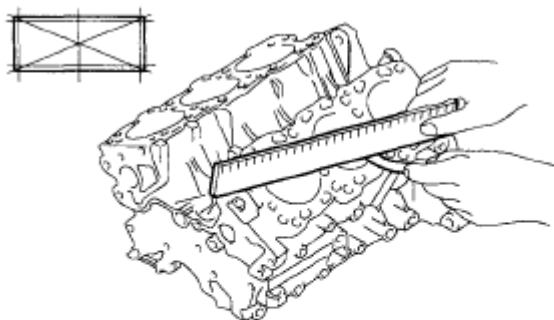
Using a soft brush and solvent, thoroughly clean the cylinder block.

3. Inspect top surface of cylinder block for flatness.

Using a precision straight edge and feeler gauge, measure the surface contacting the cylinder head gasket for warpage.

Flatness of cylinder block gasket surface

Standard: Less than 0.05 mm (0.0020 in), Less than 0.02 mm (0.0008 in) / 150 x 150



EDOF154A

**Fig. 216: Measuring Cylinder Block Gasket Surface Flatness**  
Courtesy of HYUNDAI MOTOR CO.

4. Inspect cylinder bore diameter

Visually check the cylinder for vertical scratches.

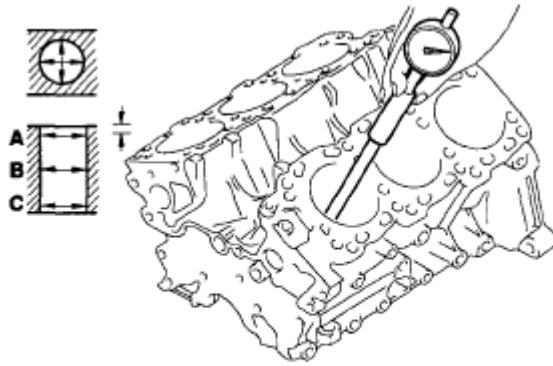
If deep scratches are present, replace the cylinder block.

5. Inspect cylinder bore diameter

Using a cylinder bore gauge, measure the cylinder bore diameter at position in the thrust and axial directions.

Standard diameter

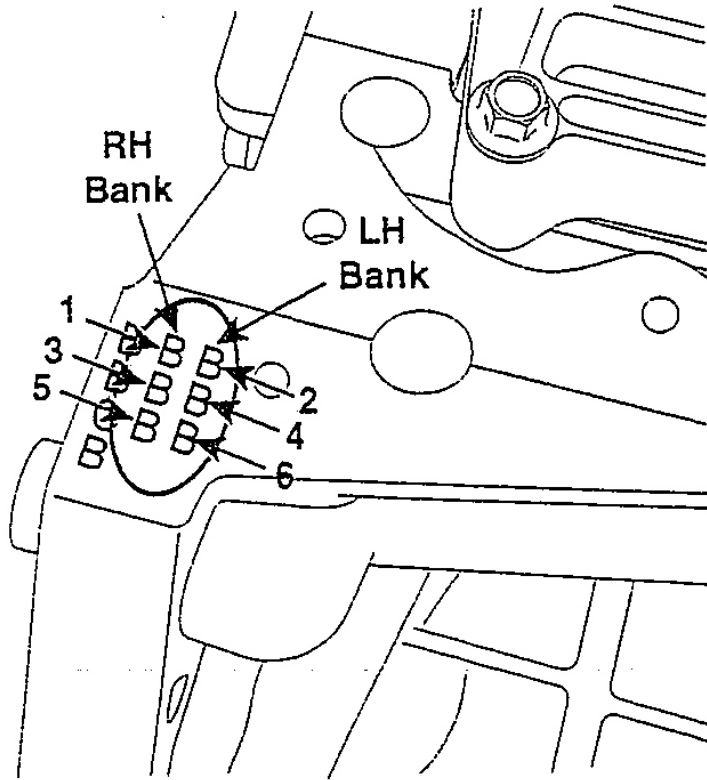
92.00 ~ 92.03 mm (3.6220 ~ 3.6232 in)



EDQF153A

**Fig. 217: Measuring Cylinder Bore Diameter**  
Courtesy of HYUNDAI MOTOR CO.

6. Check the cylinder bore size code on the cylinder block.



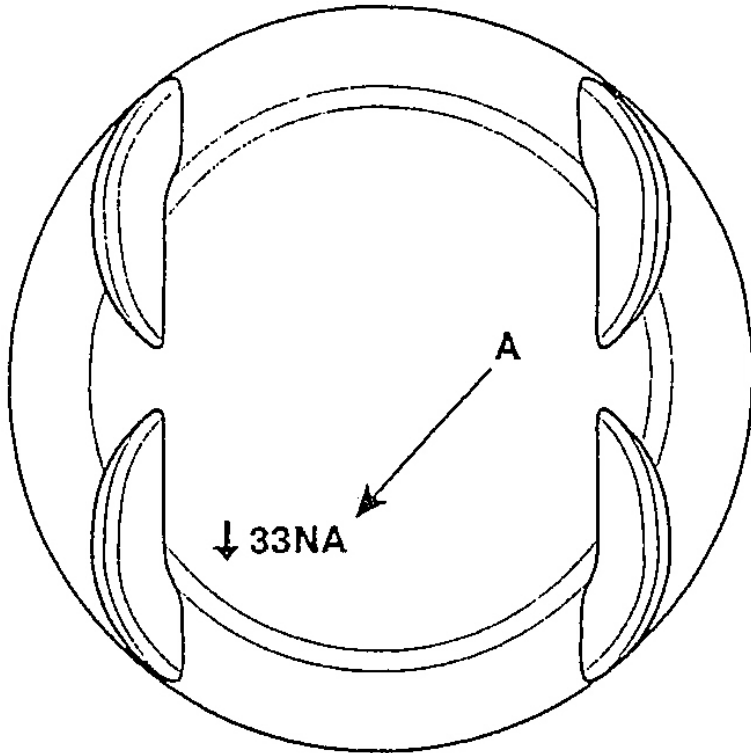
ECBF002A

**Fig. 218: Identifying Cylinder Bore Size Code On Cylinder Block**  
 Courtesy of HYUNDAI MOTOR CO.

**CYLINDER BORE INNER DIAMETER SPECIFICATIONS**

Class	Size code	Cylinder bore inner diameter
A	A	92.00~92.01 mm (3.6220 ~ 3.6224 in)
B	B	92.01 ~92.02 mm (3.6224 ~ 3.6228 in)
C	C	92.02~92.03 mm (3.6228 ~ 3.6232 in)

7. Check the piston size code on the piston top face.



UDRF001A

**Fig. 219: Identifying Piston Size Code On Piston Top Face**  
 Courtesy of HYUNDAI MOTOR CO.

**PISTON OUTER DIAMETER SPECIFICATIONS**

Class	Size code	Piston outer diameter
A	A	91.97~91.98 mm (3.6209~3.6212 in)
B	None	91.98~91.99 mm (3.6212~3.6216 in)
C	C	91.99~92.00 mm (3.6216 ~3.6220 in)

8. Select the piston related to cylinder bore class.

Clearance: 0.02 ~ 0.04 mm (0.0008 ~ 0.0016 in)

**PISTON AND RINGS**

## 1. Clean piston

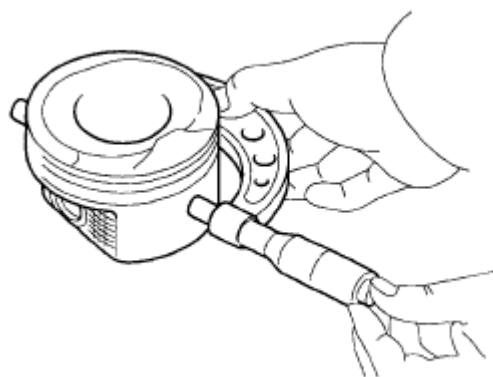
1. Using a gasket scraper, remove the carbon from the piston top.
2. Using a groove cleaning tool or broken ring, clean the piston ring grooves.
3. Using solvent and a brush, thoroughly clean the piston.

**NOTE: Do not use a wire brush.**

2. The standard measurement of the piston outside diameter is taken 14 mm (0.5512 in) from the bottom of the piston.

Standard diameter

91.97 ~ 92.00 mm (3.6209~3.6220 in)



ECKD001D

**Fig. 220: Measuring Piston Outside Diameter**  
 Courtesy of HYUNDAI MOTOR CO.

3. Calculate the difference between the cylinder bore diameter and the piston diameter.

Piston-to-cylinder clearance

0.02 ~ 0.04 mm (0.0008 ~ 0.0016 in)

4. Inspect the piston ring side clearance.

Using a feeler gauge, measure the clearance between new piston ring and the wall of the ring groove.

Piston ring side clearance

Standard

No. 1: 0.04 ~ 0.078 mm (0.0016 ~ 0.0031 in)

No. 2: 0.03 ~ 0.07 mm (0.0012 ~ 0.0027 in)

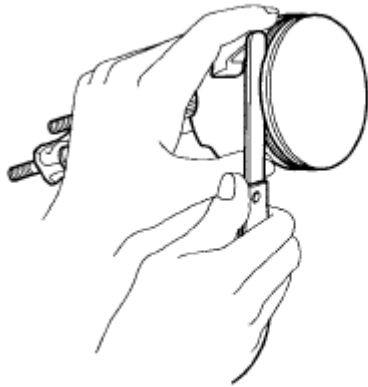
Oil ring: 0.06 ~ 0.15 mm (0.0024 ~ 0.0059 in)

Limit

No. 1: 0.1 mm (0.004 in)

No. 2: 0.1 mm (0.004 in)

Oil ring: 0.2 mm (0.008 in)



ECKD001G

**Fig. 221: Measuring Clearance Between Piston Ring And Wall Of Ring Groove**  
Courtesy of HYUNDAI MOTOR CO.

If the clearance is greater than maximum, replace the piston.

5. Inspect piston ring end gap.

To measure the piston ring end gap, insert a piston ring into the cylinder bore. Position the ring at right angles to the cylinder wall by gently pressing it down with a piston. Measure the gap with a feeler gauge. If the gap exceeds the service limit, replace the piston ring. If the gap is too large, recheck the cylinder bore diameter against the wear limits table. If the bore is over the service limit, the cylinder block must be replaced. (See **CYLINDER BLOCK**)

Piston ring end gap

Standard

No. 1: 0.17 ~ 0.32 mm (0.0067 ~ 0.0126 in)

No. 2: 0.32 ~ 0.47 mm (0.0126 ~ 0.0185 in)

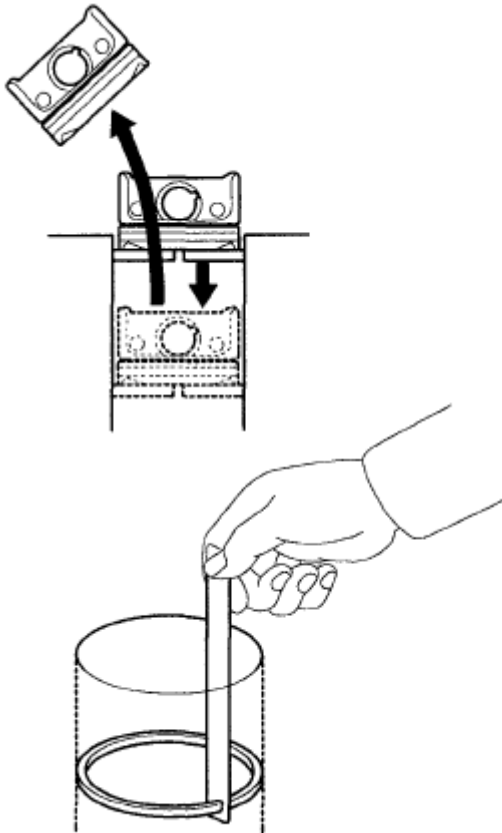
Oil ring: 0.20 ~ 0.70 mm (0.0079 ~ 0.0275 in)

Limit

No. 1: 0.6 mm (0.0236 in)

No. 2: 0.7 mm (0.0275 in)

Oil ring: 0.8 mm (0.0315 in)



ECKD001K

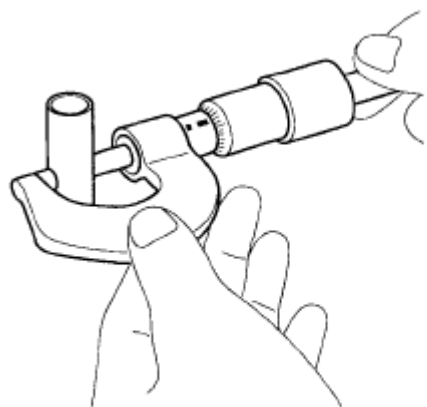
**Fig. 222: Checking Piston Ring End Gap**  
Courtesy of HYUNDAI MOTOR CO.

#### PISTON PINS

1. Measure the diameter of the piston pin.

Piston pin diameter

23.001 ~ 23.006 mm (0.9055 ~ 0.9057 in)



ECKD001Z

**Fig. 223: Measuring Diameter Of Piston Pin**  
 Courtesy of HYUNDAI MOTOR CO.

2. Measure the piston pin-to-piston clearance.

Piston pin-to-piston clearance

0.01 ~ 0.02 mm (0.0004 ~ 0.0008 in)

3. Check the difference between the piston pin diameter and the connecting rod small end diameter.

Piston pin-to-connecting rod interference

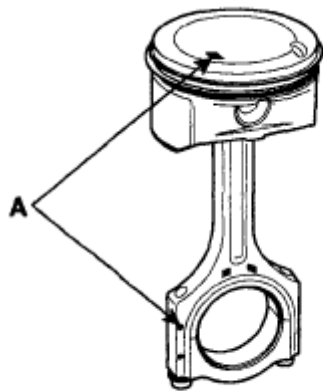
0.016 ~ 0.032 mm (0.00063 ~ 0.00126 in)

## REASSEMBLY

### NOTE:

- Thoroughly clean all parts to assembled.
- Before installing the parts, apply fresh engine oil to all sliding and rotating surfaces.
- Replace all gaskets, O-rings and oil seals with new parts.

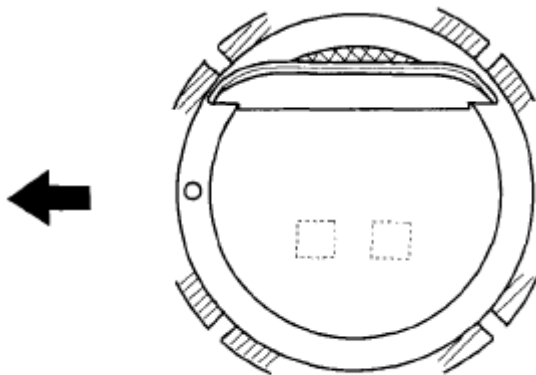
1. Assemble piston and connecting rod.
  1. Use a hydraulic press for installation.
  2. The piston front mark and the connecting rod front mark must face the timing belt side of the engine.



KCRF168A

**Fig. 224: Aligning Piston With Connecting Rod Mark**  
 Courtesy of HYUNDAI MOTOR CO.

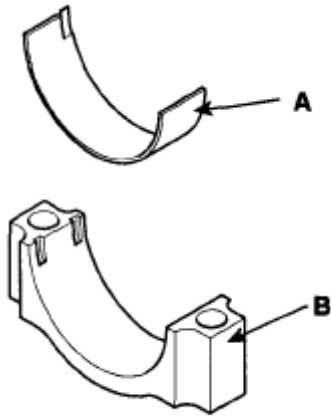
2. Install piston rings.
  1. Install the oil ring spacer and 2 side rails by hand.
  2. Using a piston ring expander, install the 2 compression rings with the code mark facing upward.
  3. Position the piston rings so that the ring ends are as shown.



ECKD321A

**Fig. 225: Identifying Piston Rings Installation Positions**  
 Courtesy of HYUNDAI MOTOR CO.

3. Install connecting rod bearings.
  1. Align the bearing claw with the groove of the connecting rod or connecting rod cap.
  2. Install the bearings (A) in the connecting rod and connecting rod cap (B).



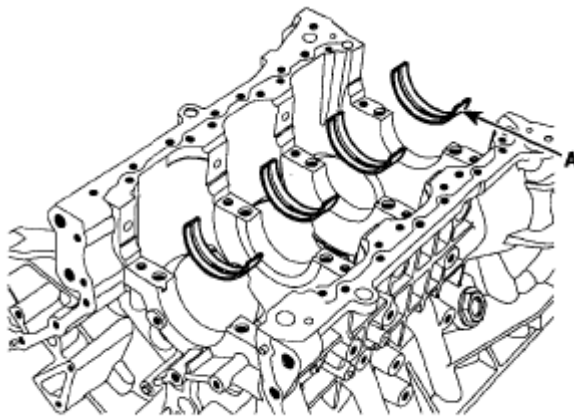
KCRF118B

**Fig. 226: Identifying Bearings And Connecting Rod Cap**  
Courtesy of HYUNDAI MOTOR CO.

4. Install main bearings.

**NOTE:** Upper bearings have an oil groove of oil holes; Lower bearings do not.

1. Align the bearing claw with the claw groove of the cylinder block, push in the 4 upper bearings (A).

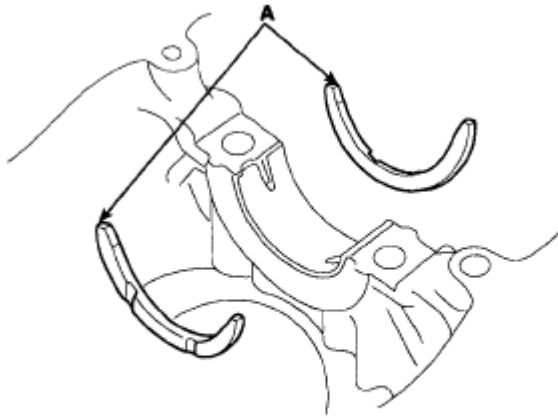


KDRF216A

**Fig. 227: Aligning Bearing Claw With Claw Groove Of Cylinder Block**  
Courtesy of HYUNDAI MOTOR CO.

2. Align the bearing claw with the claw groove of the main bearing cap, and push in the 4 lower bearings.
5. Install thrust bearings.

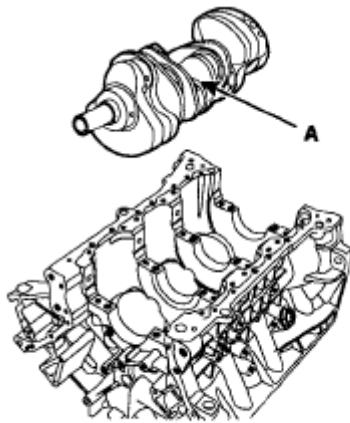
Install the 2 thrust bearings (A) under the No. 3 journal position of the cylinder block with the oil grooves facing outward.



ECKD324A

**Fig. 228: Identifying Thrust Bearings**  
Courtesy of HYUNDAI MOTOR CO.

6. Place crankshaft on the cylinder block.



KDRF210A

**Fig. 229: View Of Crankshaft And Cylinder Block**  
Courtesy of HYUNDAI MOTOR CO.

7. Place main bearing caps on cylinder block.
8. Install main bearing cap bolts.
  1. Install and uniformly tighten the bearing cap bolts, in several passes, in the sequence shown.

**Tightening torque**

Main bearing cap bolt

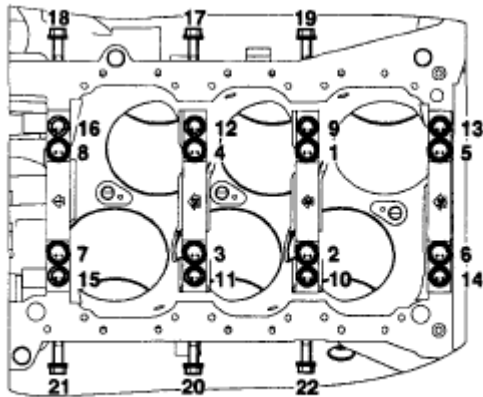
49.00 Nm (5.0 kgf.m, 36.16 lbf.ft) + 90°

19.60 Nm (2.0 kgf.m, 14.46 lbf.ft)+ 120°

29.40 ~ 31.36 Nm (3.0 ~ 3.2 kgf.m, 21.70 ~ 23.14 lbf.ft)

**NOTE:**

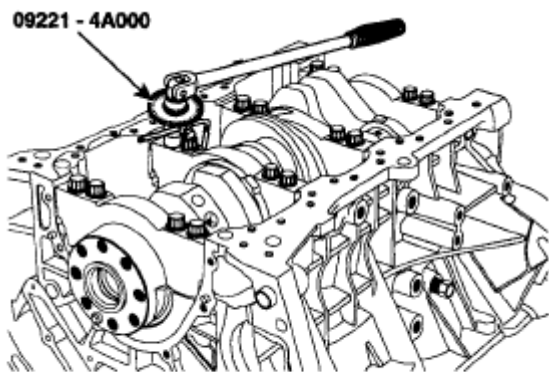
- Always use new main bearing cap bolt.
- If any of the bearing cap bolts in broken or deformed, replace it.



KDRF140A

**Fig. 230: Identifying Bearing Cap Bolts Tightening Sequence**  
 Courtesy of HYUNDAI MOTOR CO.

Use SST ( 09221-4A000 ), install main bearing cap bolts.



KDRF224A

**Fig. 231: Tightening Bearing Cap Bolts**  
 Courtesy of HYUNDAI MOTOR CO.

2. Check that the crankshaft turns smoothly.
9. Check crankshaft end play. (See **CONNECTING ROD AND CRANKSHAFT**)
10. Install piston and connecting rod assemblies.

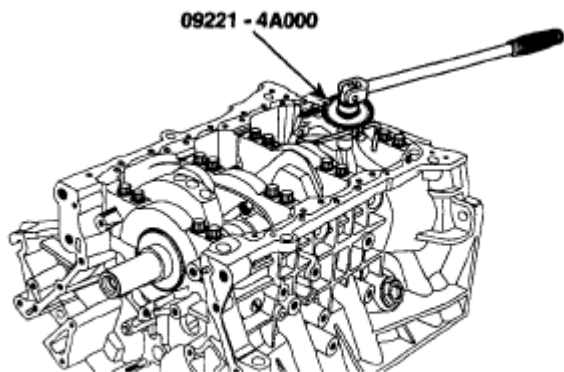
**NOTE:** Before installing the pistons, apply a coat of engine oil to the ring grooves and cylinder bores.

1. Install the ring compressor, check that the bearing is securely in place, then position the piston in the cylinder, and tap it in using the wooden handle of a hammer.
2. Stop after the ring compressor pops free, and check the connecting rod-to-check journal alignment before pushing the piston into place.
3. Apply engine oil to the bolt threads. Install the rod caps with bearings, and torque the bolts.

### Tightening torque

19.6 Nm (2.0 kgf.m, 14.46 lbf.ft) + 90°

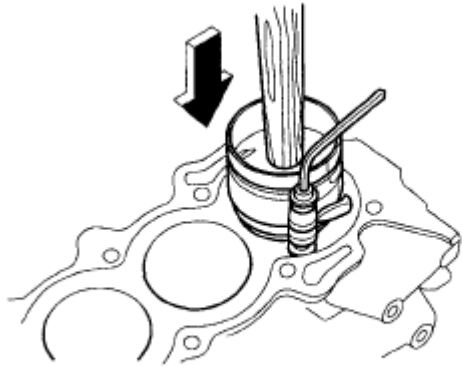
Use SST ( 09221-4A000 ), install connecting rod bearing cap bolts.



KDRF225A

**Fig. 232: Tightening Connecting Rod Bearing Cap Bolts**  
Courtesy of HYUNDAI MOTOR CO.

- NOTE:**
- Always use new connecting rod bearing cap bolt.
  - Maintain downward force on the ring compressor to prevent the rings from expanding before entering the cylinder bore.



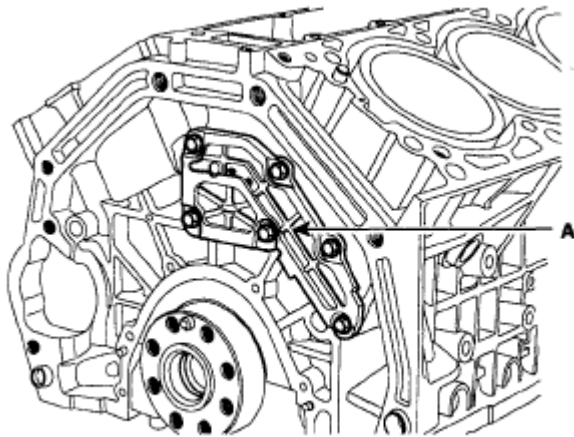
ECKD001F

**Fig. 233: Pressing Ring Compressor Into Cylinder Bore**  
 Courtesy of HYUNDAI MOTOR CO.

11. Check the connecting rod end play. (See **CONNECTING ROD AND CRANKSHAFT**)
12. Install oil drain cover.

**Tightening torque**

9.80 ~ 11.76 Nm (1.0~1.2 kgf.m, 7.23 ~ 8.67 lbf.ft)



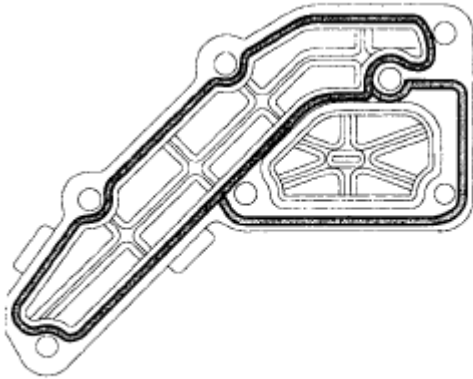
KDRF209A

**Fig. 234: Identifying Oil Drain Cover**  
 Courtesy of HYUNDAI MOTOR CO.

**NOTE:**

- Make clean the sealing face before assembling two parts.
- Remove harmful foreign matters on the sealing face before applying sealant
- Be assembling oil drain cover, the liquid sealant TB1217H should be applied oil drain cover.

- The part must be assembled within 5 minutes after sealant was applied.
- Apply sealant to the inner threads of the bolt holes.



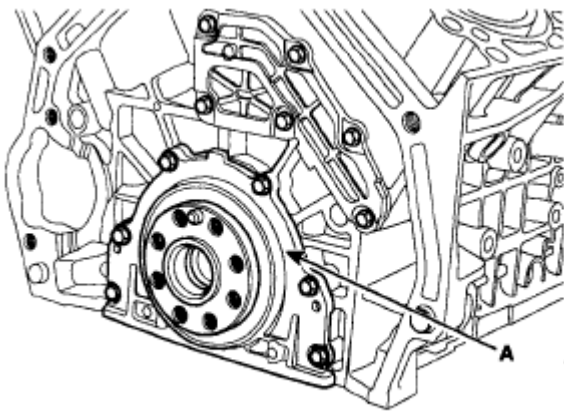
ECBF003A

**Fig. 235: Identifying Sealant Area On Oil Drain Cover**  
Courtesy of HYUNDAI MOTOR CO.

13. Install rear oil seal case.

**Tightening torque**

9.80 ~ 11.76 Nm (1.0 ~ 1.2 kgf.m, 7.23 ~ 8.67 lbf.ft)



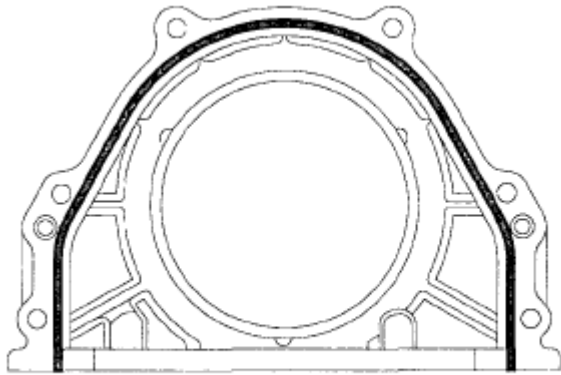
KDRF208A

**Fig. 236: Identifying Rear Oil Seal Case Cover**  
Courtesy of HYUNDAI MOTOR CO.

**NOTE:**

- Make clean the sealing face before assembling two parts.
- Remove harmful foreign matters on the sealing face before applying sealant

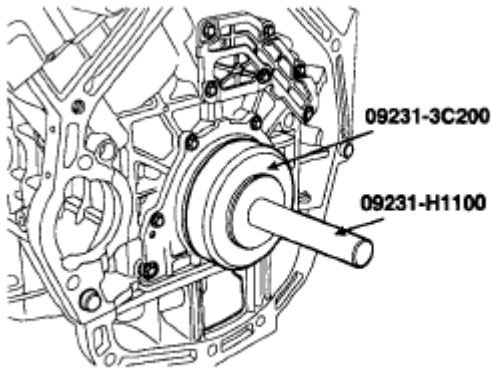
- Be assembling rear oil seal case, the liquid sealant TB1217H should be applied rear oil seal case.
- The part must be assembled within 5 minutes after sealant was applied.
- Apply sealant to the inner threads of the bolt holes.



KDRF218A

**Fig. 237: Applying Sealant To Inner Threads Of Bolt Holes**  
 Courtesy of HYUNDAI MOTOR CO.

- Using SST (09231-3C200, 09231-H1100), install rear oil seal.



KDRF237A

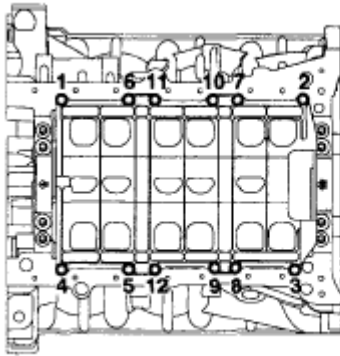
**Fig. 238: Identifying SST (09231-3C200, 09231-H1100) On Rear Oil Seal**  
 Courtesy of HYUNDAI MOTOR CO.

- Install baffle plate.

Install and uniformly tighten the baffle plate bolts, in several passes, in the sequence shown.

**Tightening torque**

9.80 ~ 11.76 Nm (1.0 ~ 1.2 kgf.m, 7.23 ~ 8.68 lbf.ft)

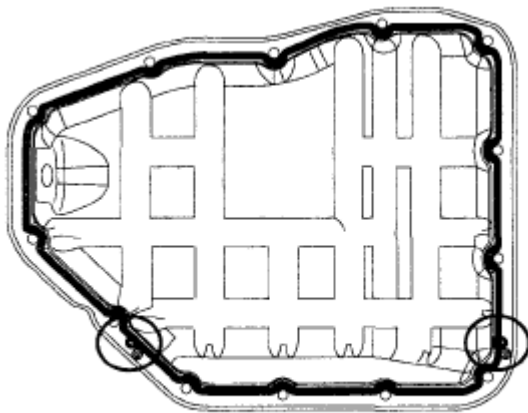


KDRF135A

**Fig. 239: Identifying Tightening Sequence Of Baffle Plate Bolts**  
 Courtesy of HYUNDAI MOTOR CO.

16. Install upper oil pan.
  - a. Using a gasket scraper, remove all the old packing material from the gasket surfaces.
  - b. Before assembling the oil pan, the liquid sealant TB1217H should be applied on upper oil pan. The part must be assembled within 5 minutes after the sealant was applied.

Bead width: 2.5 mm (0.1 in)



KDRF136A

**Fig. 240: Applying Liquid Sealant On Oil Pan**  
 Courtesy of HYUNDAI MOTOR CO.

**NOTE:**

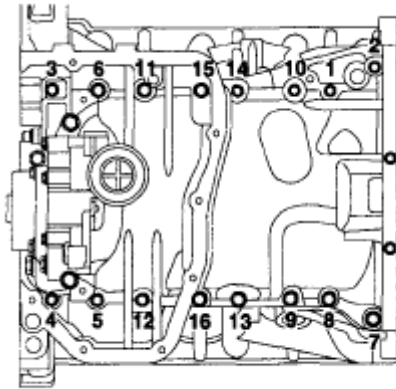
- Make clean the sealing face before assembling two parts.
- Remove harmful foreign matters on the sealing face before applying sealant
- When applying sealant gasket, sealant must not be protruded into the inside of oil pan.
- To prevent leakage of oil, apply sealant gasket to the inner threads of the bolt holes.

- c. Install oil pan.

Uniformly tighten the bolts in several passes.

**Tightening torque**

9.80 ~ 11.76 Nm (1.0 ~ 1.2 kgf.m, 7.23 ~ 8.68 lbf.ft)



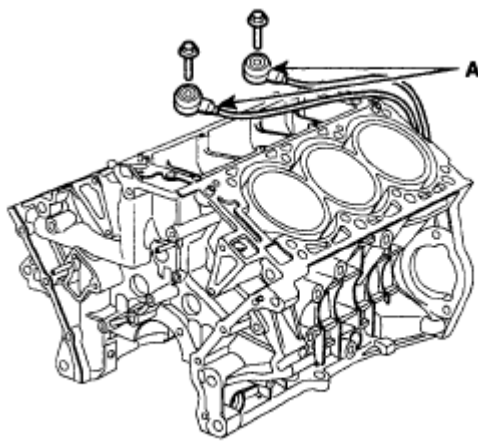
KDRF131A

**Fig. 241: Identifying Tightening Sequence Of Oil Pan Bolts**  
Courtesy of HYUNDAI MOTOR CO.

- d. After assembly, wait at least 30 minutes before filling the engine with oil.
17. Install knock sensor.

**Tightening torque**

15.68 ~ 23.52 Nm (1.6 ~ 2.4 kgf.m, 11.57 ~ 17.36 lbf.ft)



KDRF205A

**Fig. 242: Identifying Knock Sensor**  
Courtesy of HYUNDAI MOTOR CO.

18. Install drive plate.

**Tightening torque**

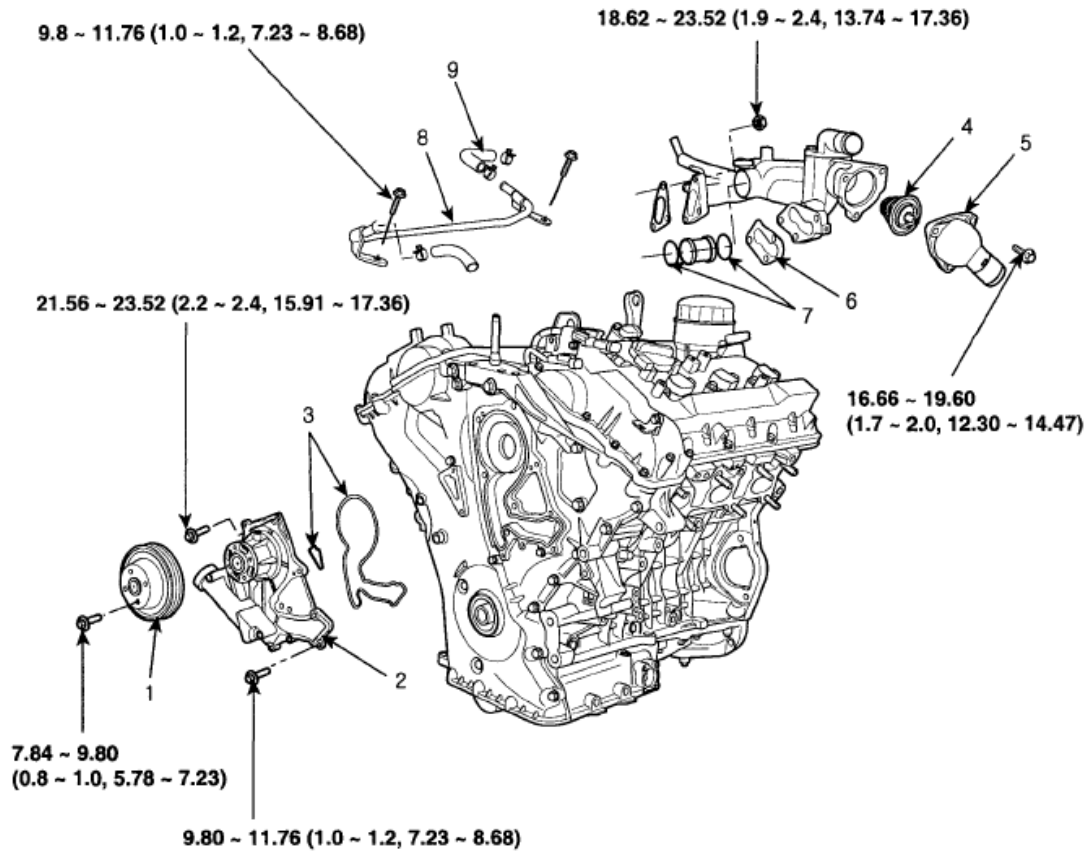
71.54 ~ 75.46 Nm (7.3 ~ 7.7 kgf.m, 52.80 ~ 55.69 lbf.ft)

**INSTALLATION**

1. Install power steering pump.
2. Install alternator.
3. Install air compressor
4. Install oil filter assembly. (See OIL FILTER ASSEMBLY)
5. Install oil pump. (See OIL PUMP)
6. Install cylinder head. (See INSTALLATION)
7. Install water temperature control assembly. (See WATER TEMPERATURE CONTROL ASSEMBLY)
8. Install timing chain. (See INSTALLATION)
9. Install intake manifold. (See INTAKE MANIFOLD)
10. Install exhaust manifold. (See EXHAUST MANIFOLD)

**COOLING SYSTEM**

**COMPONENT**



**TORQUE : N.m (kgf.m, lbf.ft)**

- |                      |                     |
|----------------------|---------------------|
| 1. Water pump pulley | 5. Water inlet pipe |
| 2. Water pump        | 6. Gasket           |
| 3. Water pump gasket | 7. O - ring         |
| 4. Thermostat        | 8. Air vent pipe    |
|                      | 9. Hose             |

EDRF007A

**Fig. 243: Identifying Cooling System Components With Torque Specifications**  
 Courtesy of HYUNDAI MOTOR CO.

**ENGINE COOLANT REFILLING AND BLEEDING**

**WARNING:** Never remove the radiator cap when the engine is hot. Serious scalding could be caused by hot fluid under high pressure escaping from the radiator.

**CAUTION:** When pouring engine coolant, be sure to shut the relay box lid and not to let coolant spill on the electrical parts or the paint. If any coolant spills, rinse it off immediately.

1. Make sure the engine and radiator are cool to the touch.

2. Remove radiator cap.
3. Loosen the drain plug, and drain the coolant.
4. Tighten the radiator drain plug securely.
5. Remove, drain and reinstall the reservoir. Fill the tank halfway to the MAX mark with water, then up to the MAX mark with antifreeze.
6. Fill fluid mixture with coolant and water (4:6) slowly through the radiator cap. Push the upper/lower hoses of the radiator so as bleed air easily.

**NOTE:**

- **Use only genuine antifreeze/coolant.**
- **For best corrosion protection, the coolant concentration must be maintained year-round at 50% minimum.**

**Coolant concentrations less than 50% may not provide sufficient protection against corrosion or freezing.**

- **Coolant concentrations greater than 60% will impair cooling efficiency and are not recommended.**

**CAUTION:**

- **Do not mix different brands of antifreeze/coolants.**
- **Do not use additional rust inhibitors or antirust products; they may not be compatible with the coolant.**

7. Start the engine and run coolant circulates.

When the cooling fan operates and coolant circulates, refill coolant through the radiator cap.

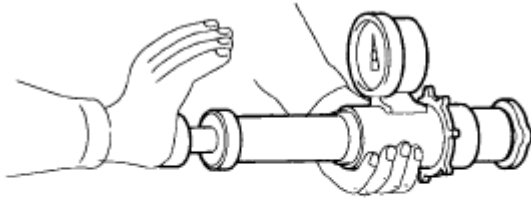
8. Repeat 7 until the cooling fan 3 ~ 5 times and bleed air sufficiently out of the cooling system.
9. Install the radiator cap and fill the reservoir tank to the "MAX" line with coolant.
10. Run the vehicle under idle until the cooling fan operates 2~3 times.
11. Stop the engine and wait coolant gets cool.
12. Repeat 6 to 11 until the coolant level doesn't fall any more, bleed air out of the cooling system.

**NOTE:**

**As it is to bleed air out to the cooling system and refill coolant when coolant gets cool completely, recheck the coolant level in the reservoir tank for 2 ~ 3 days after replacing coolant.**

**CAP TESTING**

1. Remove the radiator cap, wet its seal with engine coolant, then install it no pressure tester.



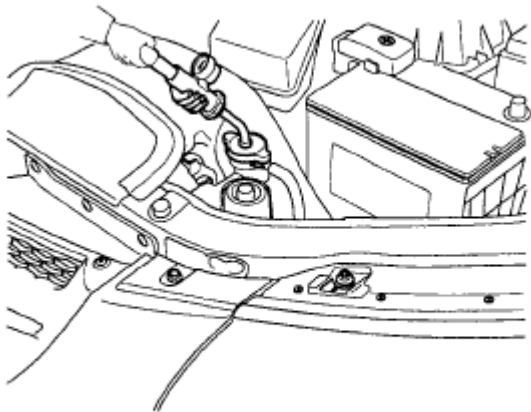
ECKD501X

**Fig. 244: Applying Pressure To Radiator Cap**  
 Courtesy of HYUNDAI MOTOR CO.

2. Apply a pressure of 93 ~ 123 kPa (0.95 ~ 1.25 kgf/cm<sup>2</sup> , 14 ~ 19 psi)
3. Check for a drop in pressure.
4. If the pressure drops, replace the cap.

**TESTING**

1. Wait until engine is cool, then carefully remove the radiator cap and fill the radiator with engine coolant, then install it on the pressure tester.



KCRF184A

**Fig. 245: Applying Pressure Tester To Radiator**  
 Courtesy of HYUNDAI MOTOR CO.

2. Apply a pressure tester to the radiator and apply a pressure of 93 ~ 123 kPa (0.95 ~ 1.25 kgf/cm<sup>2</sup> 14 ~18 psi).
3. Inspect for engine coolant leaks and a drop in pressure.
4. Remove the tester and reinstall the radiator cap.

**NOTE:** Check for engine oil in the coolant and/or coolant in the engine oil.

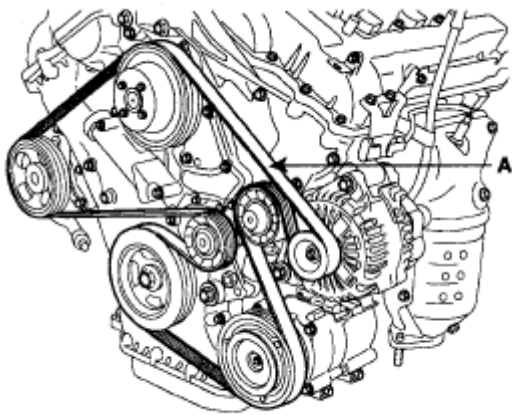
## REMOVAL

### WATER PUMP

1. Drain the engine coolant.

**WARNING:** System is under high pressure when the engine is hot. To avoid danger of releasing scalding engine coolant, remove the cap only when the engine is cool.

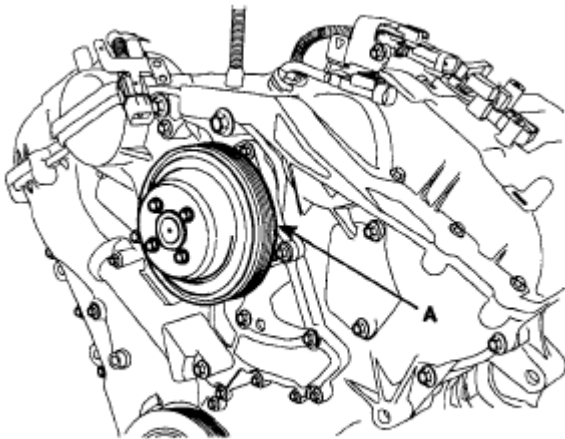
2. Remove drive belt (A).



KDRF101A

**Fig. 246: Identifying Drive Belt**  
Courtesy of HYUNDAI MOTOR CO.

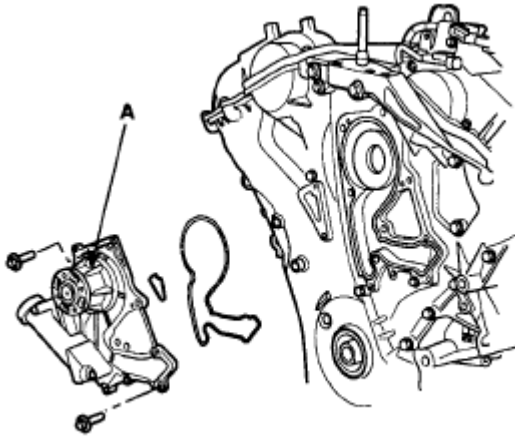
3. Remove the 4 bolts and pump pulley (A).



KDRF107A

**Fig. 247: Identifying Pump Pulley With Bolts**  
Courtesy of HYUNDAI MOTOR CO.

4. Remove the water pump (A) and gasket.

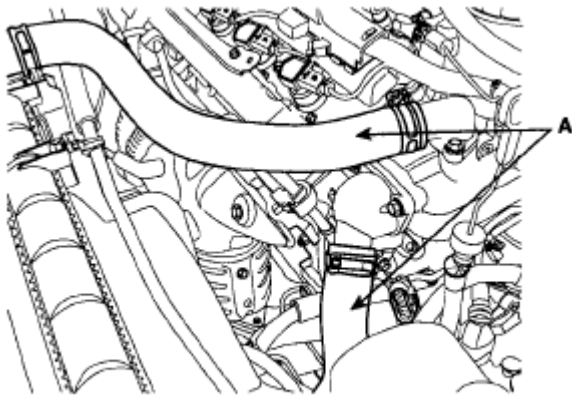


KDRF221A

**Fig. 248: Identifying Water Pump And Gasket**  
Courtesy of HYUNDAI MOTOR CO.

**WATER TEMPERATURE CONTROL ASSEMBLY**

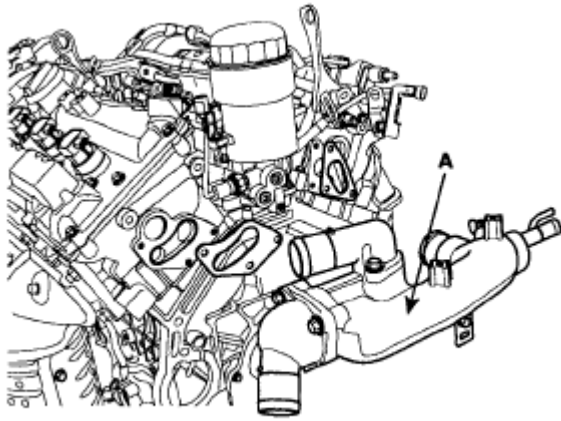
1. Drain the engine coolant.
2. Remove air cleaner assembly. (See **REMOVAL**)
3. Disconnect radiator upper and lower hose (A).



KDRF148A

**Fig. 249: Identifying Radiator Upper And Lower Hose**  
Courtesy of HYUNDAI MOTOR CO.

4. Disconnect WTS connector. (See **REMOVAL**)
5. Disconnect heater hose, water vent hose and water hose from water temperature control assembly.
6. Remove wiring protector.
7. Remove water temperature control assembly (A).



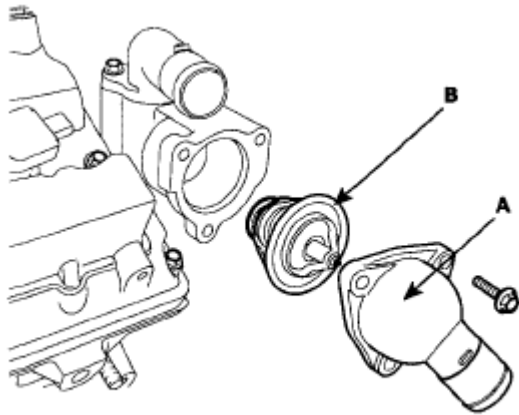
KDRF194A

**Fig. 250: Identifying Water Temperature Control Assembly**  
Courtesy of HYUNDAI MOTOR CO.

### THERMOSTAT

**NOTE:** Removal of the thermostat would have an adverse effect, causing a lowering of cooling efficiency. Do not remove the thermostat, even if the engine tends to overheat.

1. Drain engine coolant so its level is below thermostat.
2. Remove water inlet (A) and thermostat (B).

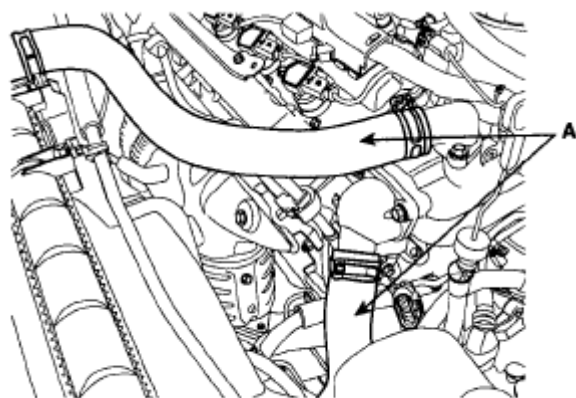


KDRF195A

**Fig. 251: Identifying Water Inlet And Thermostat**  
Courtesy of HYUNDAI MOTOR CO.

### RADIATOR

1. Drain the engine coolant.
2. Disconnect radiator upper and lower hoses (A).



KDRF148A

**Fig. 252: Identifying Radiator Upper And Lower Hoses**  
Courtesy of HYUNDAI MOTOR CO.

3. Disconnect transaxle oil cooler hoses. (See, AUTOMATIC TRANSAXLE (A5HF1) or AUTOMATIC TRANSAXLE (F4A42) ).
4. Remove radiator bracket.
5. Remove radiator assembly.

## INSPECTION

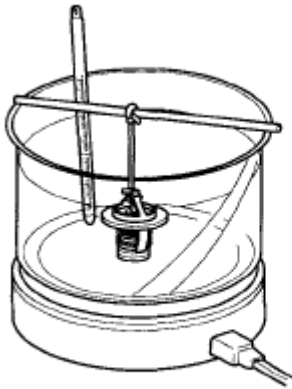
### WATER PUMP

1. Check each part for cracks, damage or wear, and replace the coolant pump assembly if necessary.
2. Check the bearing for damage, abnormal noise and sluggish rotation, and replace the coolant pump assembly if necessary.
3. Check for coolant leakage. If coolant leaks from hole, the seal is defective. Replace the coolant pump assembly.

**NOTE:** A small amount of "weeping" from the bleed hole is normal.

### THERMOSTAT

1. Immerse the thermostat in water and gradually heat the water.



ECKD503B

**Fig. 253: Heating Thermostat Valve**  
Courtesy of HYUNDAI MOTOR CO.

2. Check the valve opening temperature.

Valve opening temperature: 82°C (177°F)

Full opening temperature: 95°C (205°F)

If the valve opening temperature is not as specified, replace the thermostat.

3. Check the valve lift.

Valve lift: Min. 10 mm (0.4 in) at 95°C (205°F)

If the valve lift is not as specified, replace the thermostat.

## INSTALLATION

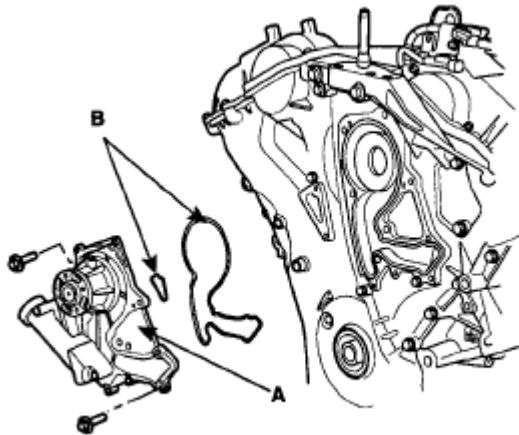
### WATER PUMP

1. Install the water pump (A) and a new gasket (B) with 12 bolts.

#### **Tightening torque**

21.56 ~ 23.52 Nm (2.2 ~ 2.4 kgf.m, 15.91 ~ 17.36 lbf.ft)

9.80 ~ 11.76 Nm (1.0 ~ 1.2 kgf.m, 7.23 ~ 8.68 lbf.ft)



KDRF221B

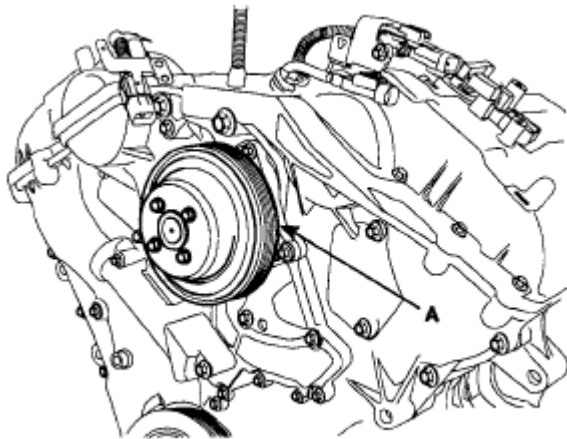
**Fig. 254: Identifying Water Pump And Gasket With Bolts**  
Courtesy of HYUNDAI MOTOR CO.

**NOTE:** Make clean the contact face before assembly.

2. Install the 4 bolts and pump pulley (A).

**Tightening torque**

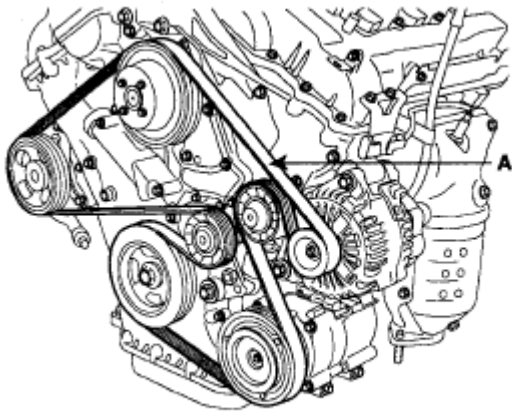
7.84 ~ 9.80 Nm (0.8 ~ 1.0 kgf.m, 5.78 ~ 7.23 lbf.ft)



KDRF107A

**Fig. 255: Identifying Pump Pulley With Bolts**  
Courtesy of HYUNDAI MOTOR CO.

3. Install drive belt (A).



KDRF101A

**Fig. 256: Identifying Drive Belt**  
Courtesy of HYUNDAI MOTOR CO.

4. Fill with engine coolant.
5. Start engine and check for leaks.
6. Recheck engine coolant level.

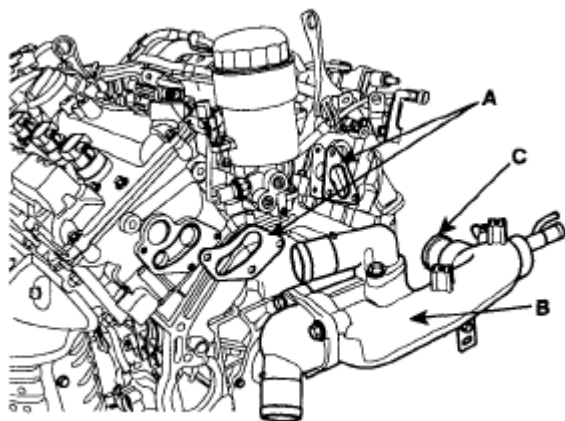
**WATER TEMPERATURE CONTROL ASSEMBLY**

**NOTE: Make clean the contact face before assembly.**

1. Install water temperature control assembly (A) and new gasket (B).

**Tightening torque**

18.62 ~ 23.52 Nm (1.9 ~ 2.4 kgf.m, 13.74 ~ 17.36 lbf.ft)

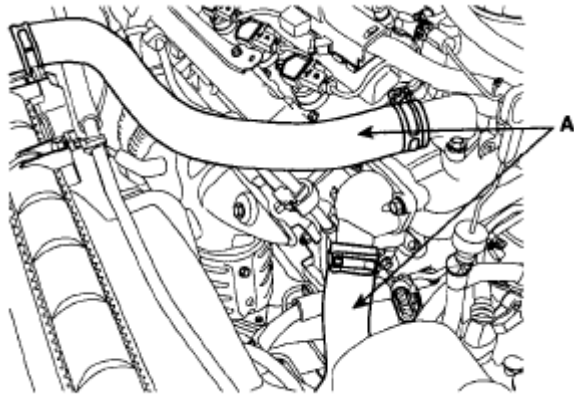


KDRF194B

**Fig. 257: Identifying Water Temperature Control Assembly And Gasket**  
Courtesy of HYUNDAI MOTOR CO.

**NOTE:** Use new O-rings (C) when reassembling.

2. Connect water hoses to the water temperature control assembly.
3. Install wiring protector.
4. Connect WTS connector.
5. Connect radiator upper and lower hose (A).



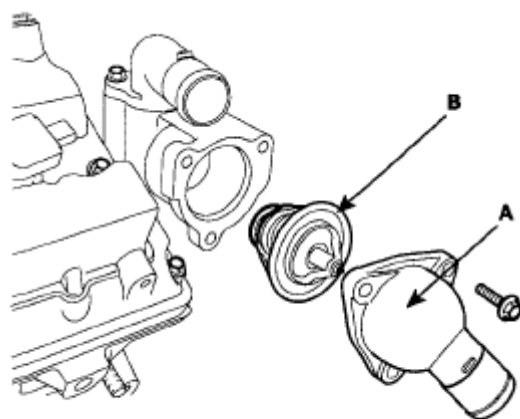
KDRF148A

**Fig. 258: Identifying Radiator Upper And Lower Hose**  
Courtesy of HYUNDAI MOTOR CO.

6. Install air cleaner assembly.
7. Fill with engine coolant.
8. Start engine and check for leaks.
9. Recheck engine coolant level.

#### THERMOSTAT

1. Place thermostat in thermostat housing.
  1. Install the thermostat with the jiggle valve upward.
  2. Install a new thermostat (B).



KDRF195A

**Fig. 259: Identifying Thermostat With Jiggle Valve**  
 Courtesy of HYUNDAI MOTOR CO.

2. Install water inlet (A).

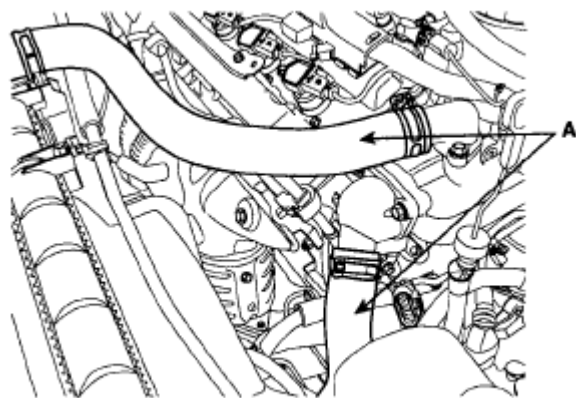
**Tightening torque**

16.66 ~ 19.60 Nm (1.7 ~ 2.0 kgf.m, 12.30 ~ 14.47 lbf.ft)

3. Fill with engine coolant.
4. Start engine and check for leaks.

**RADIATOR**

1. Install radiator assembly.
2. Install radiator upper bracket.
3. Connect transaxle oil cooler hoses (See, **AUTOMATIC TRANSAXLE (A5HF1)** or **AUTOMATIC TRANSAXLE (F4A42)** ).
4. Connect radiator upper and lower hoses (A).



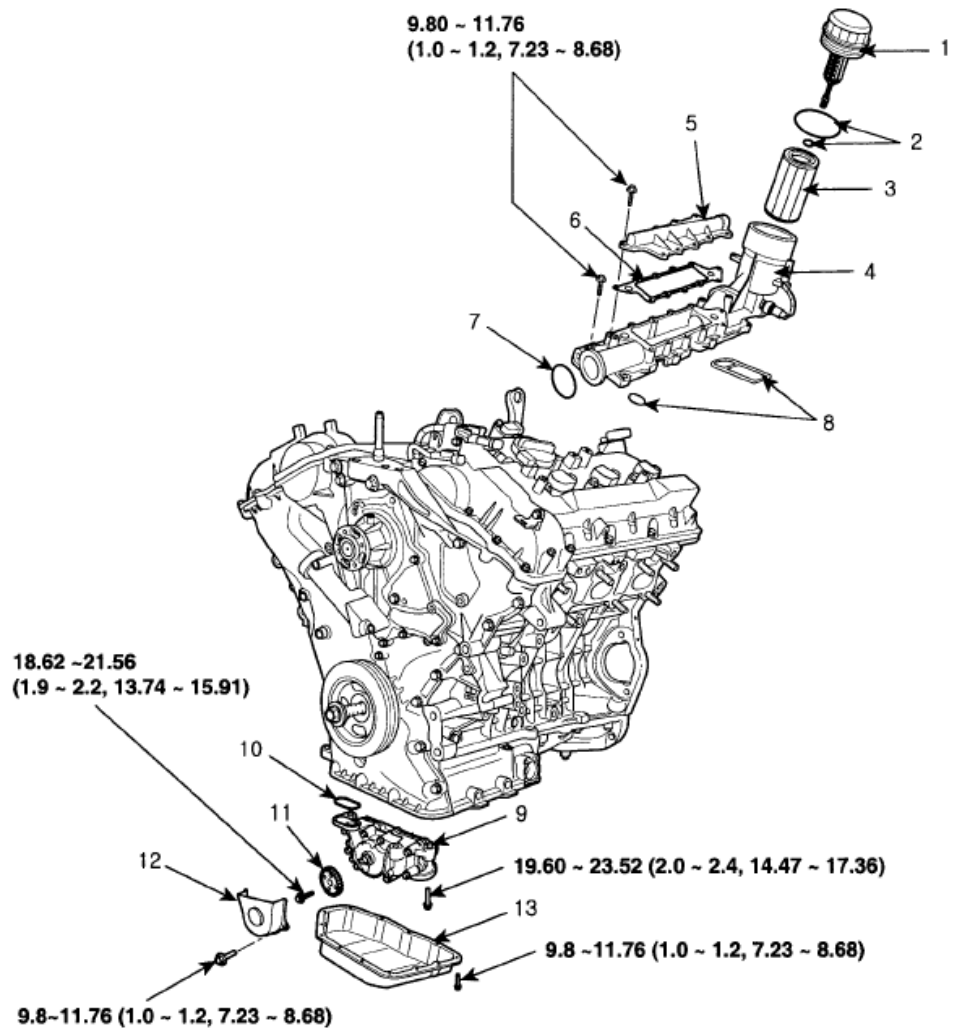
KDRF148A

**Fig. 260: Identifying Radiator Upper And Lower Hoses**  
 Courtesy of HYUNDAI MOTOR CO.

5. Fill with engine coolant.
6. Start engine and check for leaks.
7. Recheck engine coolant level.

## LUBRICATION SYSTEM

### COMPONENT



**TORQUE : N.m (kgf.m, lbf.ft)**

- |                          |             |                          |
|--------------------------|-------------|--------------------------|
| 1. Oil filter cap        | 6. Gasket   | 11. Oil pump sprocket    |
| 2. O - ring              | 7. O - ring | 12. Oil pump chain cover |
| 3. Oil filter element    | 8. Gasket   | 13. Lower oil paon       |
| 4. Oil filter body       | 9. Oil pump |                          |
| 5. Oil filter body cover | 10. Gasket  |                          |

EDRF008A

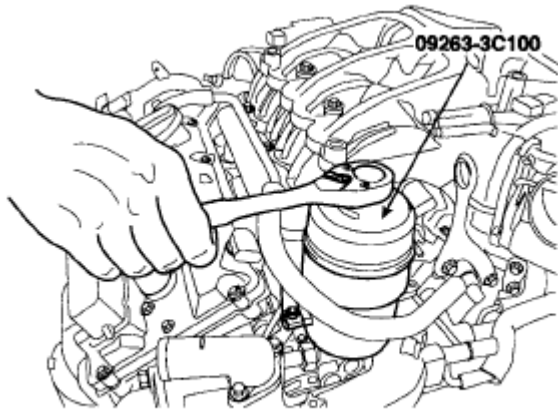
**Fig. 261: Identifying Lubrication System Components With Torque Specifications**  
Courtesy of HYUNDAI MOTOR CO.

## OIL AND FILTER

### CAUTION:

- Prolonged and repeated contact with mineral oil will result in the removal of natural fats from the skin, leading to dryness, irritation and dermatitis. In addition, used engine oil contains potentially harmful contaminants which may cause skin cancer.
- Exercise caution in order to minimize the length and frequency of contact of your skin to used oil. Wear protective clothing and gloves. Wash your skin thoroughly with soap and water, or use water-less hand cleaner, to remove any used engine oil. Do not use gasoline, thinners, or solvents.
- In order to preserve the environment, used oil and used oil filter must be disposed of only at designated disposal sites.

1. Park car on level ground. Start engine and let it warm up.
2. Turn engine off. Open hood and remove engine cover.
3. Wait for 5 minutes after loosening the oil filler cap by turning it counterclockwise (with SST 09263-3C100) to drain well the oil in the oil filter.

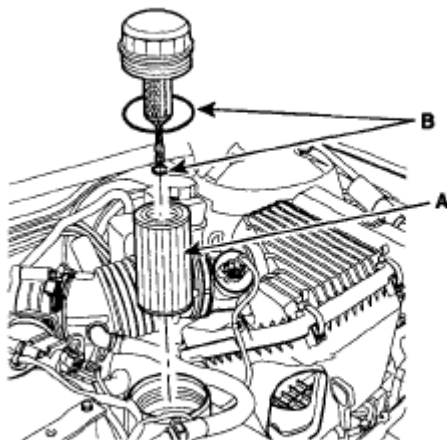


ECRF051A

**Fig. 262: Identifying Oil Filter Cap**  
Courtesy of HYUNDAI MOTOR CO.

4. Drain the engine oil:
  - a. Remove the oil filler cap.
  - b. After lifting car, remove oil drain plug and drain the oil into a container.
5. Replace oil filter.
  - a. Disconnect the oil filter cap from oil filter body.
  - b. Remove the oil filter element.

- c. Check and clean the oil filter installation surface.
- d. Check the part number of the new oil filter is as same as old one.
- e. Install new oil filter element (A) and two O-rings (B).



KDRF188A

**Fig. 263: Identifying Oil Filter Element And O-Rings**  
 Courtesy of HYUNDAI MOTOR CO.

- f. Apply clean engine oil to the new o-rings. Lightly screw the oil filter cap into place, and tighten it until the O-ring contacts the seat.
- g. Finally, tighten oil filter cap to specified torque.

**Tightening torque**

24.50 Nm (2.5 kgf.m, 18.08 lbf.ft)

- 6. Refill with engine oil.
  - a. Clean and install the oil drain plug with a new gasket.

**Tightening torque**

34.3 ~ 44.1 Nm (3.5 ~ 4.5 kgf.m, 25.3 ~ 32.5 lbf.ft)

- b. Fill with fresh engine oil

**Capacity**

Drain and refill

W/Oil filter change: 5.9L (6.23 U.S.qts, 5.19 Imp.qts)

W/O Oil filter change: 5.5L (5.81 U.S.qts, 4.84 Imp.qts)

Oil filter: 0.4L (0.42 U.S.qts, 0.35 Imp.qts)

- c. Install the oil filter cap.
7. Start engine and check for oil leaks.
8. Recheck engine oil level.

**INSPECTION**

1. Check engine oil quality.

Check the oil for deterioration, entry of water, discoloring or thinning.

If the quality is visibly poor, replace the oil.

2. Check engine oil level.

After warming up the engine and then 5 minutes after the engine stop, oil level should be between the "L" and "F" marks on the dipstick.

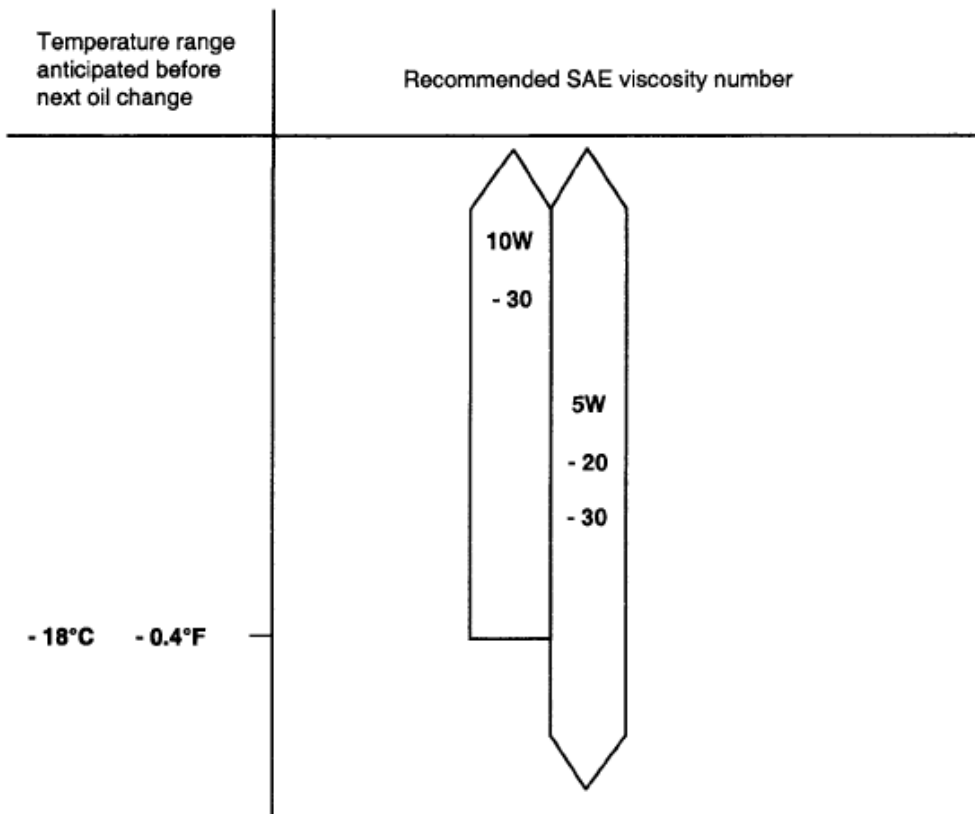
If low, check for leakage and add oil up to the "F" mark.

**NOTE: Do not fill with engine oil above the "F" mark.**

**SELECTION OF ENGINE OIL**

Recommended API classification: Above SJ or SL Recommended SAE viscosity grades: 5W-20

If 5W-20 engine oil is not available, 5W-30 or secondary recommended engine oil for corresponding temperature range can be used.



EDRF020A

**Fig. 264: Engine Oil Viscosity Chart**  
 Courtesy of HYUNDAI MOTOR CO.

**NOTE:** For best performance and maximum protection of all types of operation, select only those lubricants which

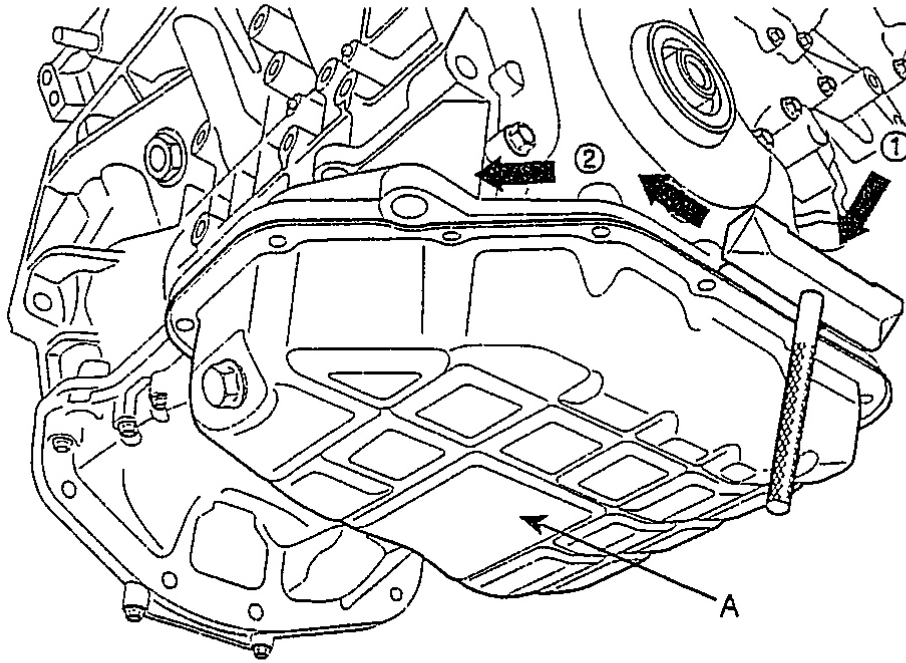
- Satisfy the requirement of the API classification.
- Have proper SAE grade number for expected ambient temperature range.

Lubricants that do not have both an SAE grade number and API service classification on the container should not be used.

**REMOVAL**

**OIL PUMP**

1. Drain engine oil.
2. Using SST (09215-3C000) remove lower oil pan (A).



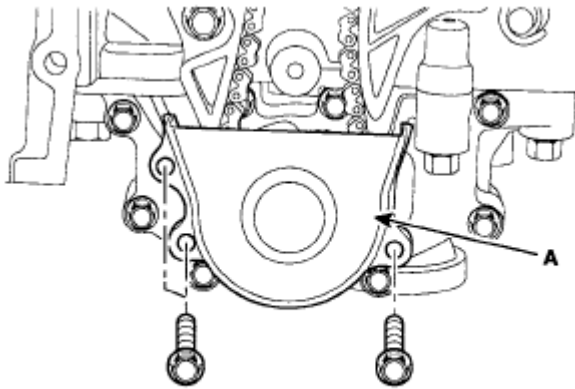
SNFM17001N

**Fig. 265: Removing Lower Oil Pan Using Special Tool**  
 Courtesy of HYUNDAI MOTOR CO.

**CAUTION:** Be careful not to damage the contact surfaces of Upper oil pan and lower oil pan.

- Insert the SST between the oil pan and the ladder frame by tapping it with a plastic hammer in the direction of (1) arrow.
- After tapping the SST with a plastic hammer along the direction of (2) arrow around more than 2/3 edge of the oil pan, remove it from the ladder frame.
- Do not turn over the SST abruptly without tap-ping. It be result in damage of the SST.

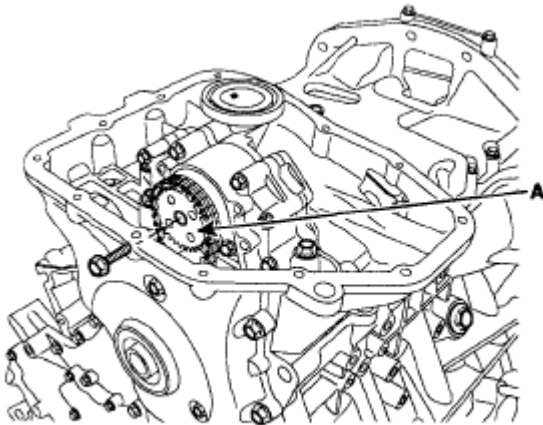
3. Remove oil pump chain cover (A).



KDRF185A

**Fig. 266: Identifying Oil Pump Chain Cover**  
Courtesy of HYUNDAI MOTOR CO.

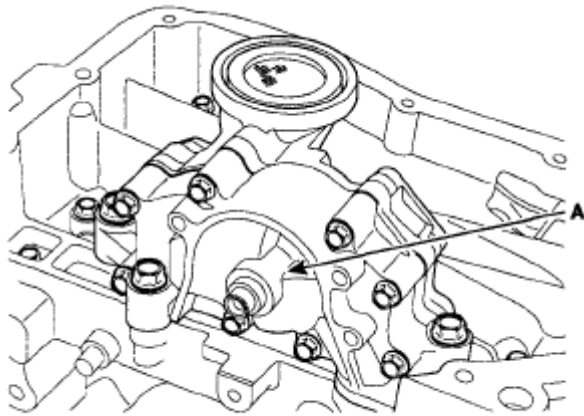
4. Remove oil pump chain sprocket (A).



KDRF189A

**Fig. 267: Identifying Oil Pump Chain Sprocket**  
Courtesy of HYUNDAI MOTOR CO.

5. Remove oil pump (A).

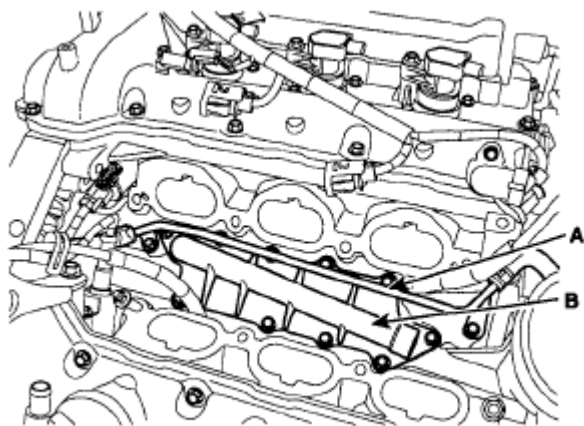


KDRF190A

**Fig. 268: Identifying Oil Pump**  
 Courtesy of HYUNDAI MOTOR CO.

**OIL FILTER ASSEMBLY**

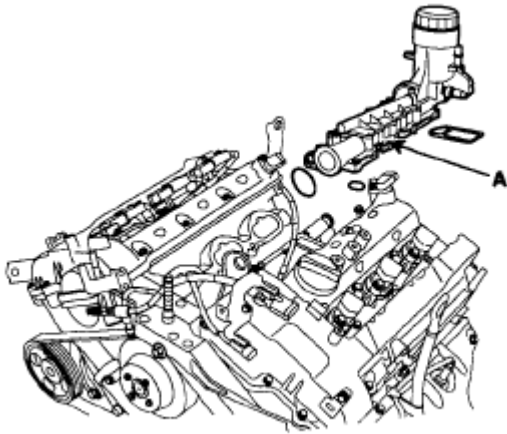
1. Loosen the oil filter cap by turning it counterclockwise to drain well the oil in the oil filter.
2. Remove surge tank and intake manifold. (See **REMOVAL**)
3. Disconnect oil pressure switch connector. (See **REMOVAL**)
4. Drain the engine coolant.
5. Disconnect water hoses from ETC.
6. Remove water temperature control assembly. (See **WATER TEMPERATURE CONTROL ASSEMBLY**)
7. Disconnect water vent hose (A).
8. Remove oil filter body cover (B).



KDRF191A

**Fig. 269: Identifying Water Vent Hose And Oil Filter Body Cover**  
 Courtesy of HYUNDAI MOTOR CO.

- Remove oil filter body (A).



KDRF192A

**Fig. 270: Identifying Oil Filter Body**  
 Courtesy of HYUNDAI MOTOR CO.

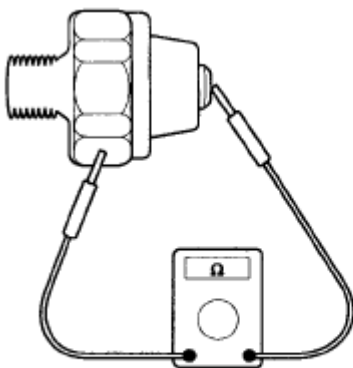
**NOTE:** Be careful of the knock sensor connector.

**INSPECTION**

**OIL PRESSURE SWITCH**

- Check the continuity between the terminal and the body with an ohmmeter.

If there is no continuity, replace the oil pressure switch.



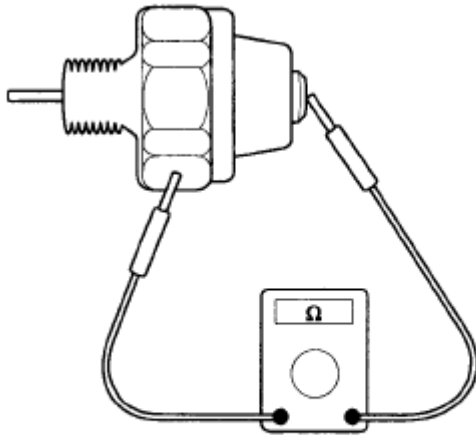
ECKD001W

**Fig. 271: Checking Continuity Between Oil Pressure Switch Terminal**  
 Courtesy of HYUNDAI MOTOR CO.

- Check the continuity between the terminal and the body when the fine wire is pushed. If there is continuity even when the fine wire is pushed, replace the switch.

3. If there is no continuity when a 50 kpa (7 psi) vacuum is applied through the oil hole, the switch is operating properly.

Check for air leakage. If air leaks, the diaphragm is broken. Replace it.



ECKD001Y

**Fig. 272: Checking Continuity Between Terminal And Body With Fine Wire Pushed**  
Courtesy of HYUNDAI MOTOR CO.

## INSTALLATION

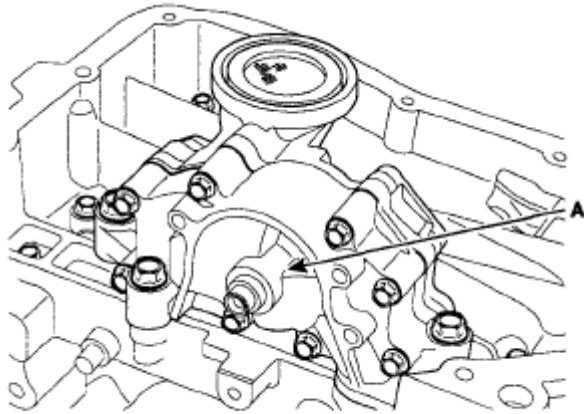
### OIL PUMP

1. Install oil pump (A).

#### Tightening torque

19.60 ~ 23.52 Nm (2.0 ~ 2.4 kgf.m, 14.47 ~ 17.36 lbf.ft)

**NOTE:** Always use a new O-ring.



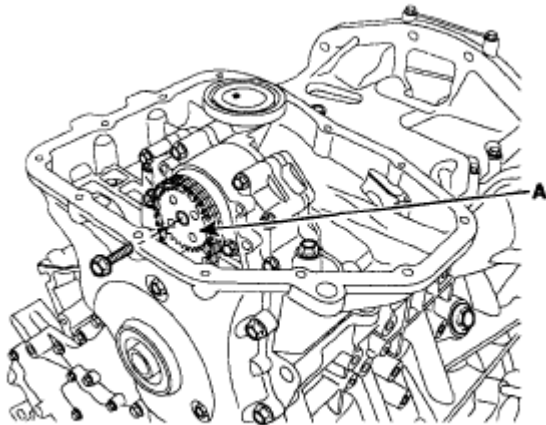
KDRF190A

**Fig. 273: Identifying Oil Pump**  
Courtesy of HYUNDAI MOTOR CO.

2. Install oil pump sprocket (A) and oil pump chain on the oil pump.

**Tightening torque**

18.62 ~ 21.56 Nm (1.9 ~ 2.2 kgf.m, 13.74 ~ 15.91 lbf.ft)



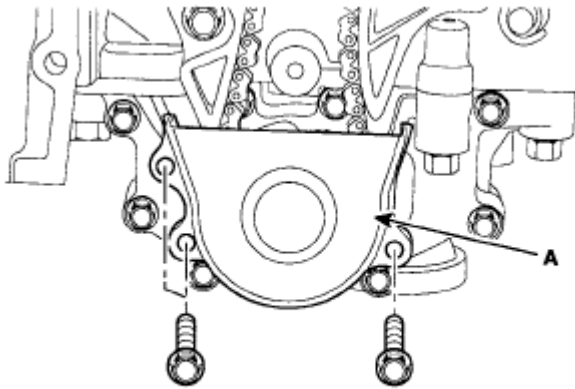
KDRF189A

**Fig. 274: Identifying Oil Pump Sprocket**  
Courtesy of HYUNDAI MOTOR CO.

3. Install oil pump chain cover (A).

**Tightening torque**

9.80 ~ 11.76 Nm (1.0 ~ 1.2 kgf.m, 7.23 ~ 8.68 lbf.ft)

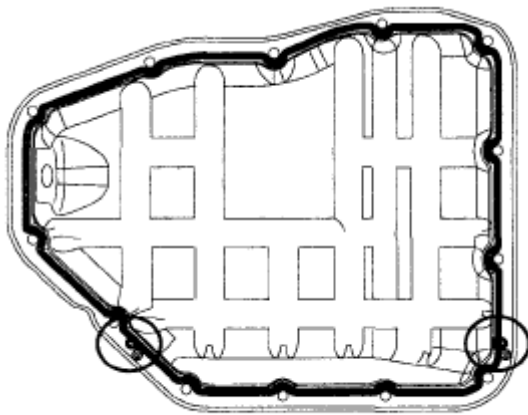


KDRF185A

**Fig. 275: Identifying Oil Pump Chain Cover**  
Courtesy of HYUNDAI MOTOR CO.

4. Install upper oil pan.
  - a. Using a gasket scraper, remove all the old packing material from the gasket surfaces.
  - b. Before assembling the oil pan, the liquid sealant TB1217H should be applied on upper oil pan. The part must be assembled within 5 minutes after the sealant was applied.

Bead width: 2.5mm (0.1 in)



KDRF136A

**Fig. 276: Applying Liquid Sealant On Upper Oil Pan**  
Courtesy of HYUNDAI MOTOR CO.

**CAUTION:**

- Make clean the sealing face before assembling two parts.
- Remove harmful foreign matters on the sealing face before applying sealant
- When applying sealant gasket, sealant must not be protruded into the inside of oil pan.

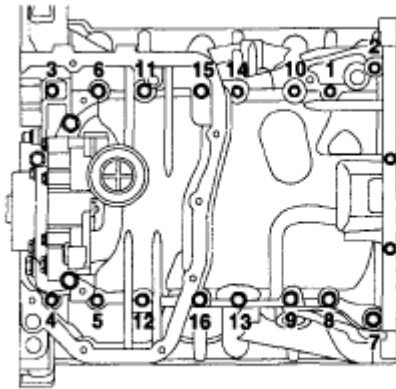
- To prevent leakage of oil, apply sealant gasket to the inner threads of the bolt holes.

c. Install upper oil pan.

Uniformly tighten the bolts in several passes.

**Tightening torque**

9.80 ~ 11.76 Nm (1.0~1.2 kgf.m, 7.23 ~ 8.68 lbf.ft)



KDRF131A

**Fig. 277: Identifying Tightening Sequence Of Oil Pan Bolts**  
Courtesy of HYUNDAI MOTOR CO.

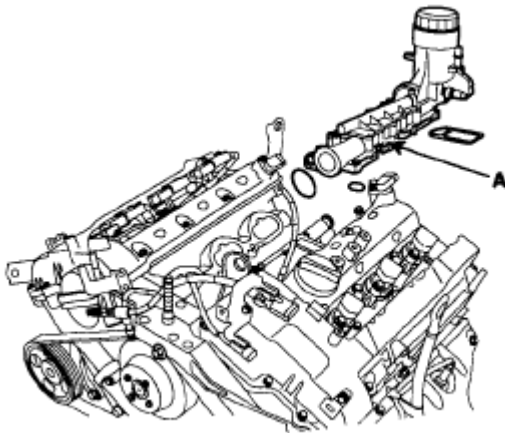
d. After assembly, wait at least 30 minutes before filling the engine with oil.

**OIL FILTER ASSEMBLY**

1. Install oil filter body (A) and new O-rings.

**Tightening torque**

9.80 ~ 11.76 Nm (1.0 ~ 1.2 kgf.m, 7.23 ~ 8.68 lbf.ft)



KDRF192A

**Fig. 278: Identifying Oil Filter Body**  
Courtesy of HYUNDAI MOTOR CO.

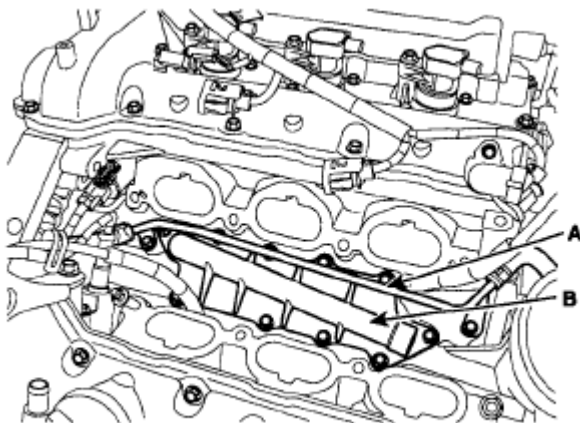
**NOTE:**

- All rubber gasket must be no damaged by assembling parts.
- Be careful of the knock sensor connector.
- Always use a new O-ring

2. Install oil filter body cover (A) and new gasket on the oil filter body.

**Tightening torque**

9.80 ~ 11.76 Nm (1.0 ~ 1.2 kgf.m, 7.23 ~ 8.68 lbf.ft)



KDRF191A

**Fig. 279: Identifying Oil Filter Body Cover And Gasket**  
Courtesy of HYUNDAI MOTOR CO.

3. Connect water vent hose (B)

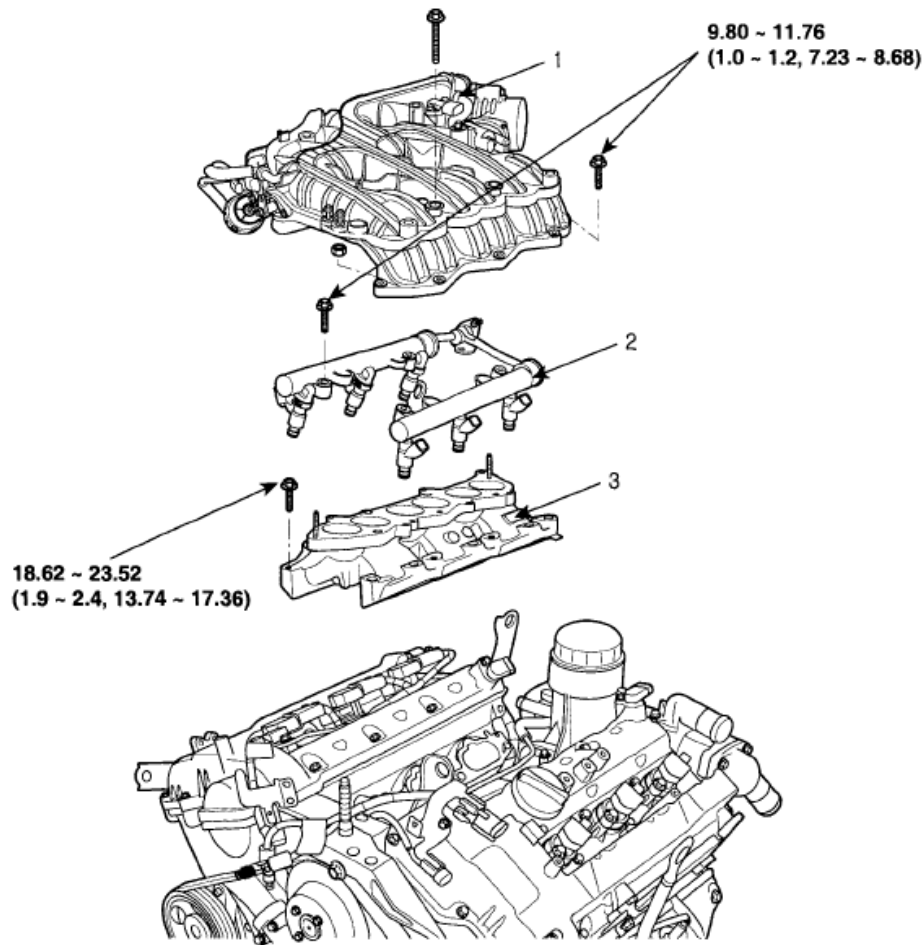
**Tightening torque**

9.80 ~ 11.76 Nm (1.0 ~ 1.2 kgf.m, 7.23 ~ 8.68 lbf.ft)

4. Install water temperature control assembly. (See **WATER TEMPERATURE CONTROL ASSEMBLY**)
5. Connect water hoses on the ETC.
6. Connect oil pressure switch connector. (See **REMOVAL**)
7. Install intake manifold and surge tank. (See **INTAKE MANIFOLD**)
8. Fill with engine coolant.
9. Start engine and check for leaks.
10. Recheck engine coolant level.

## **INTAKE AND EXHAUST SYSTEM**

### **COMPONENT**

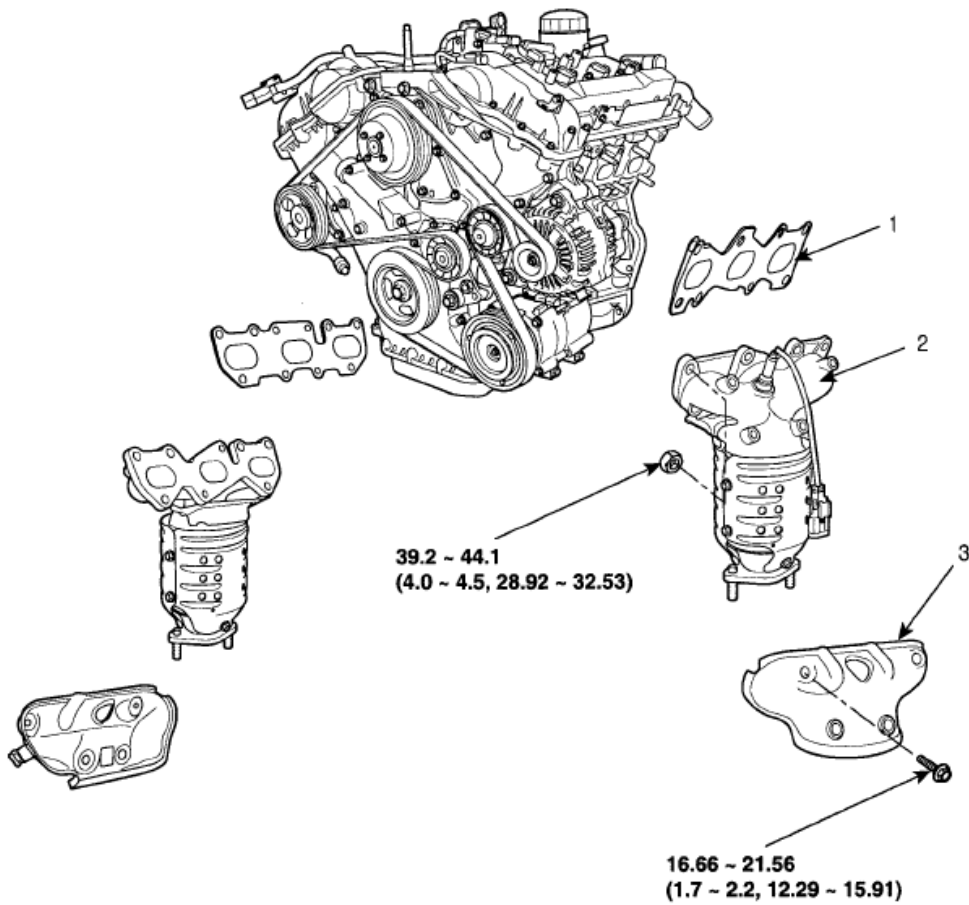


**TORQUE : N.m (kgf.m, lbf.ft)**

- 1. Surge tank
- 2. Delivery pipe
- 3. Intake manifold

EDRF009A

**Fig. 280: Identifying Intake System Components With Torque Specifications**  
Courtesy of HYUNDAI MOTOR CO.

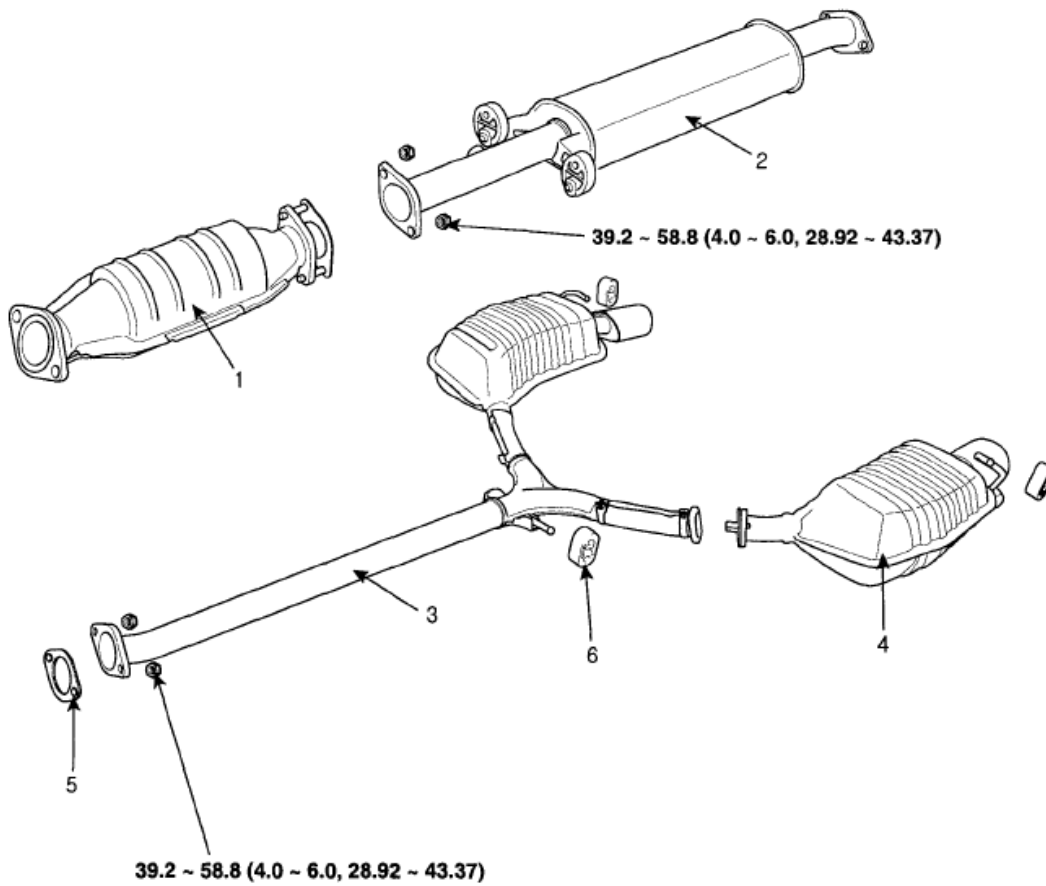


**TORQUE : N.m (kgf.m, lbf.ft)**

- 1. Gasket
- 2. Exhaust manifold
- 3. Heat protector

EDRF010A

**Fig. 281: Identifying Exhaust System Components With Torque Specifications (1 Of 2)**  
Courtesy of HYUNDAI MOTOR CO.



**TORQUE : N.m (kgf.m, lbf.ft)**

- |                        |                  |
|------------------------|------------------|
| 1. Catalytic converter | 4. LH muffler    |
| 2. Center muffler      | 5. Gasket        |
| 3. Main muffler        | 6. Rubber hanger |

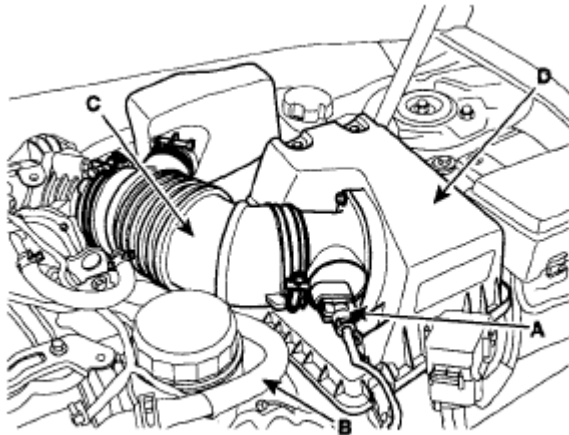
EDRF229A

**Fig. 282: Identifying Exhaust System Components With Torque Specifications (2 Of 2)**  
 Courtesy of HYUNDAI MOTOR CO.

**REMOVAL**

**INTAKE MANIFOLD**

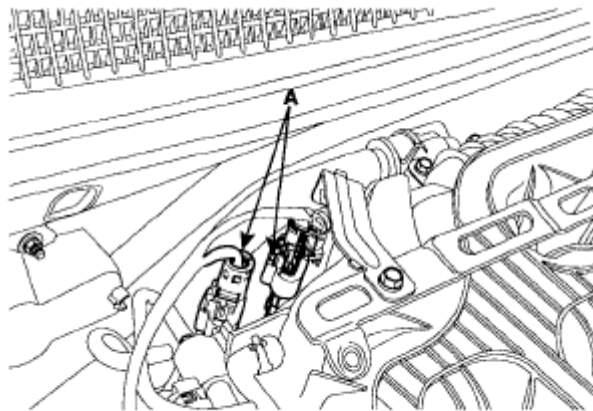
1. Disconnect AFS (A) and breather hose (B).
2. Remove air cleaner upper cover (D) and intake hose (C).



KDRF173A

**Fig. 283: Identifying Air Cleaner Upper Cover And Intake Hose With AFS**  
Courtesy of HYUNDAI MOTOR CO.

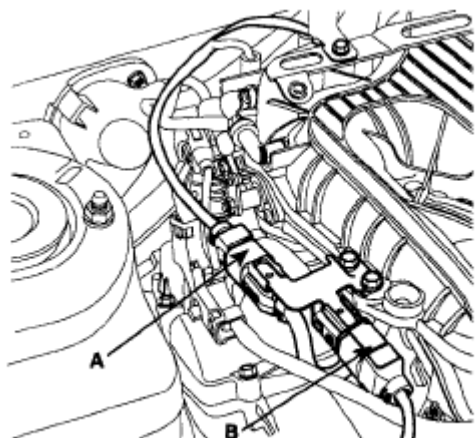
3. Disconnect RH oxygen sensor connector (A).



KDRF151A

**Fig. 284: Identifying RH Oxygen Sensor Connector**  
Courtesy of HYUNDAI MOTOR CO.

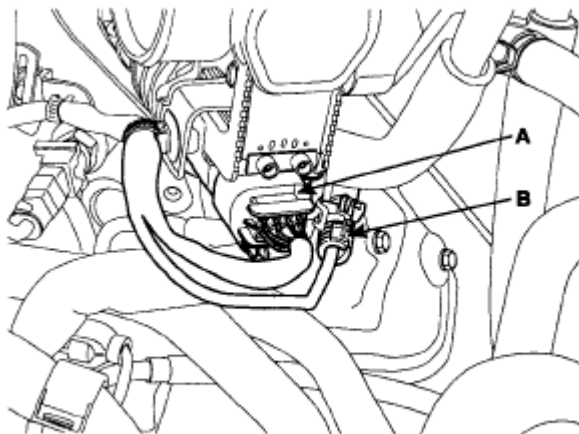
4. Disconnect RH injector connector (A) and ignition coil connector (B).



KDRF153A

**Fig. 285: Identifying RH Injector Connector And Ignition Coil Connector**  
Courtesy of HYUNDAI MOTOR CO.

5. Disconnect ETC connector (A) and knock sensor connector (B).



KDRF162A

**Fig. 286: Identifying ETC Connector And Knock Sensor Connector**  
Courtesy of HYUNDAI MOTOR CO.

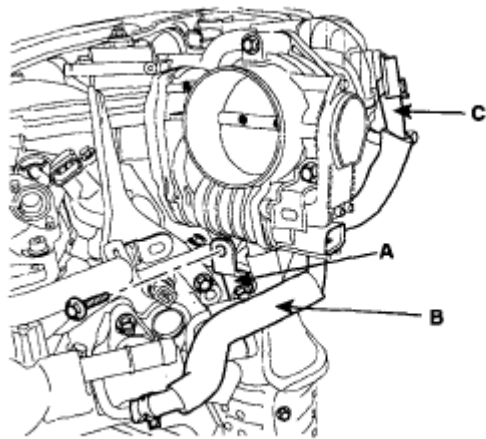
6. Disconnect PCSV connector (A), MAP sensor connector (A) and PCSV hose.



KDRF160A

**Fig. 287: Identifying PCSV Connector, MAP Sensor Connector And PCSV Hose**  
Courtesy of HYUNDAI MOTOR CO.

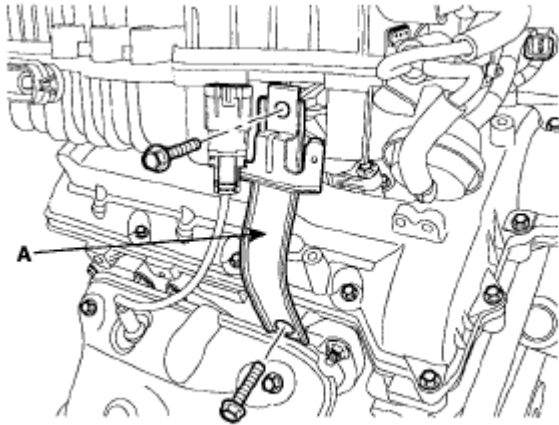
7. Remove ETC bracket (A).
8. Disconnect water hoses (B) from ETC.
9. Disconnect PCV (C) hose.



KDRF176A

**Fig. 288: Identifying ETC Bracket, Water Hoses And PCV Hose**  
Courtesy of HYUNDAI MOTOR CO.

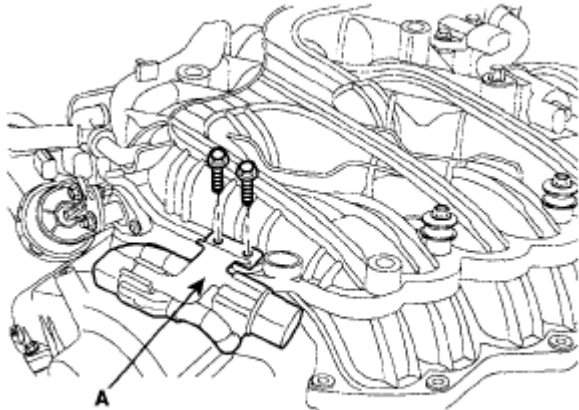
10. Disconnect brake vacuum hose.
11. Remove surge tank bracket (A).



KDRF177A

**Fig. 289: Identifying Surge Tank Bracket**  
Courtesy of HYUNDAI MOTOR CO.

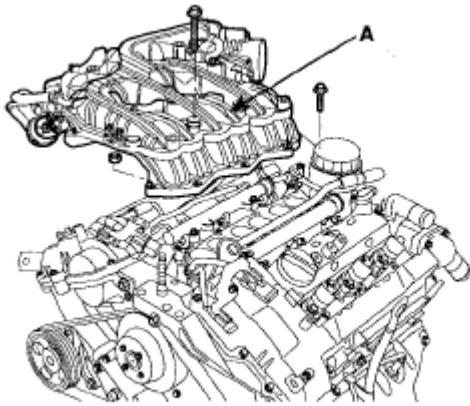
12. Remove connector bracket (A) from surge tank.



KDRF178A

**Fig. 290: Identifying Connector Bracket**  
Courtesy of HYUNDAI MOTOR CO.

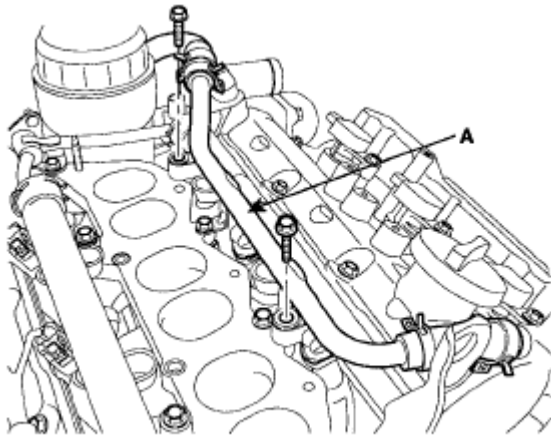
13. Remove surge tank (A).



KDRF179A

**Fig. 291: Identifying Surge Tank**  
Courtesy of HYUNDAI MOTOR CO.

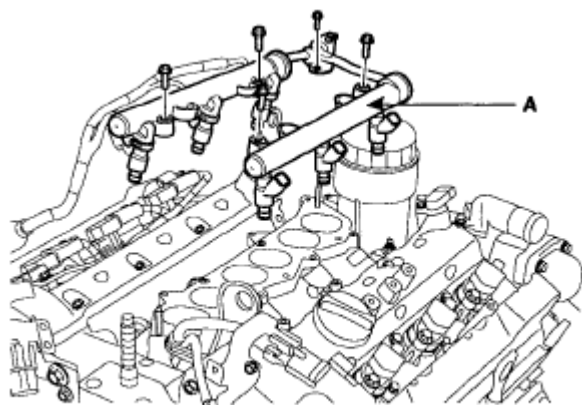
14. Disconnect breather hose (A).



KDRF180A

**Fig. 292: Identifying Breather Hose**  
Courtesy of HYUNDAI MOTOR CO.

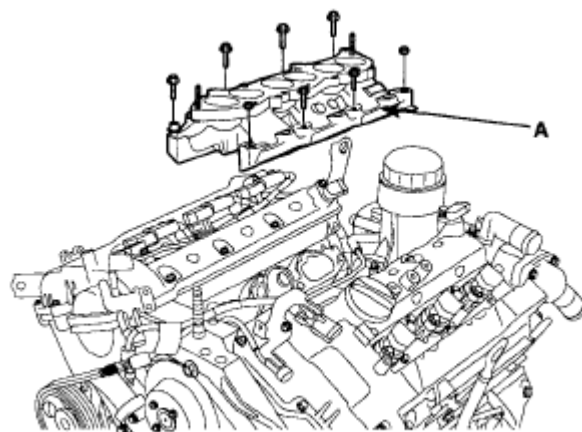
15. Disconnect LH injector connector.
16. Remove delivery pipe (A).



KDRF181A

**Fig. 293: Identifying Delivery Pipe**  
Courtesy of HYUNDAI MOTOR CO.

17. Remove intake manifold (A) and gasket.

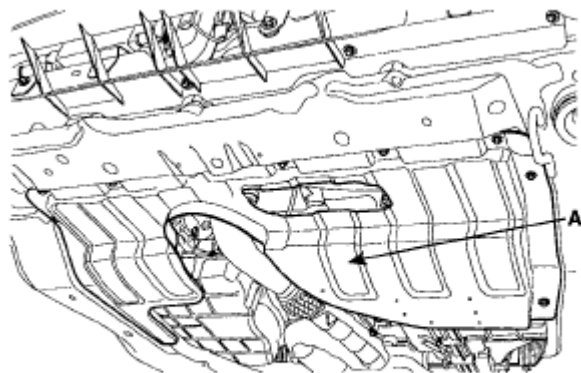


KDRF182A

**Fig. 294: Identifying Intake Manifold And Gasket**  
Courtesy of HYUNDAI MOTOR CO.

#### EXHAUST MANIFOLD

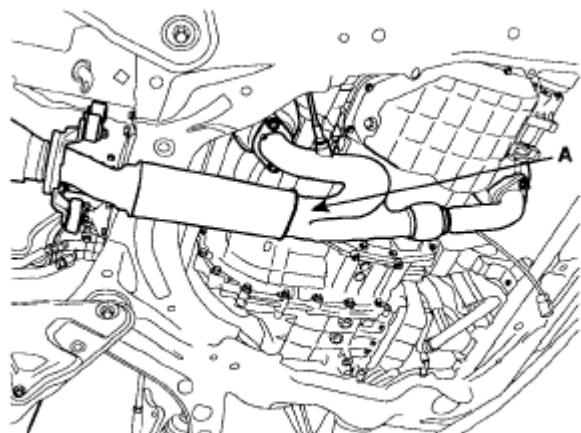
1. Remove under cover (A).



KDRF147A

**Fig. 295: Identifying Under Cover**  
Courtesy of HYUNDAI MOTOR CO.

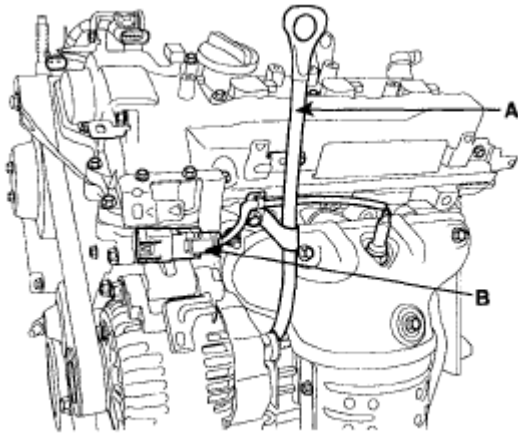
2. Disconnect LH.RH rear oxygen sensor connector from bracket.
3. Remove front muffler (A).



KDRF170A

**Fig. 296: Identifying Front Muffler**  
Courtesy of HYUNDAI MOTOR CO.

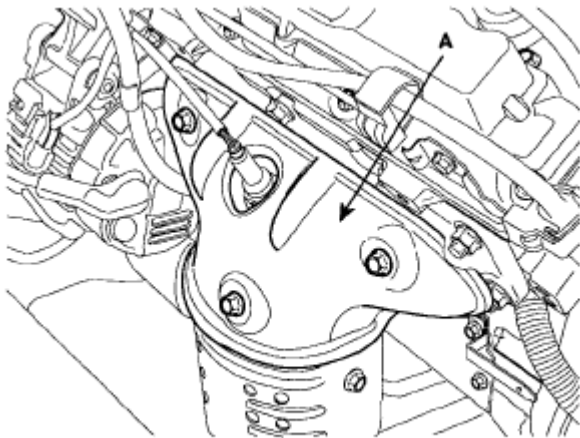
4. Remove oil level gauge (A).
5. Disconnect LH front oxygen sensor connector (B) from bracket.



KDRF1B3A

**Fig. 297: Identifying LH Front Oxygen Sensor Connector And Oil Level Gauge**  
Courtesy of HYUNDAI MOTOR CO.

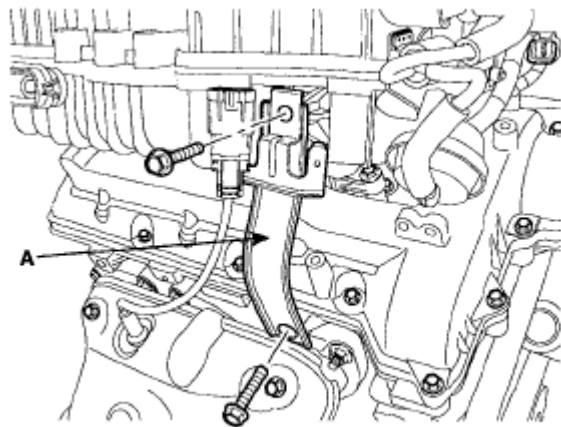
6. Remove LH heat protector.



KDRF1B4A

**Fig. 298: Identifying LH Heat Protector**  
Courtesy of HYUNDAI MOTOR CO.

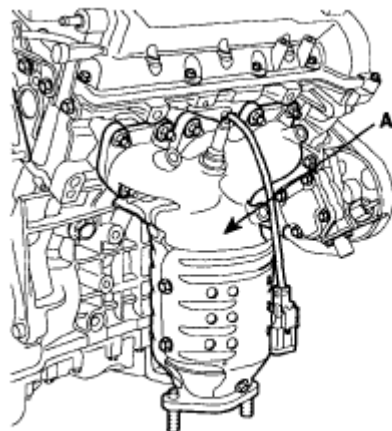
7. Remove LH exhaust manifold.
8. Disconnect RH front oxygen sensor connector from bracket.



KDRF177A

**Fig. 299: Identifying RH Front Oxygen Sensor Connector**  
Courtesy of HYUNDAI MOTOR CO.

9. Remove RH heat protector.
10. Remove RH exhaust manifold.



KDRF187A

**Fig. 300: Identifying RH Exhaust Manifold**  
Courtesy of HYUNDAI MOTOR CO.

## INSTALLATION

### INTAKE MANIFOLD

1. Install intake manifold and new gasket on the cylinder head.

#### **Tightening torque**

18.62 ~ 23.52 Nm (1.9 ~ 2.4 kgf.m, 13.74 ~ 17.36 lbf.ft)

**NOTE: Be careful of the installation direction.**

2. Install delivery pipe. (See **FUEL DELIVERY SYSTEM** )
3. Connect LH injector connector.
4. Connect breather hose.

**Tightening torque**

9.80 ~ 11.76 Nm (1.0~1.2 kgf.m, 7.23 ~ 8.68 lbf.ft)

5. Install surge tank.

**Tightening torque**

9.80 ~ 11.76 Nm (1.0 ~ 1.2 kgf.m, 7.23 ~ 8.68 lbf.ft)

6. Install connector bracket on the surge tank.

**Tightening torque**

6.86 ~ 10.78 Nm (0.7 ~ 1.1 kgf.m, 5.06 ~ 7.96 lbf.ft)

7. Install surge tank stay.

**Tightening torque**

27.44 ~ 31.36 Nm (2.8 ~ 3.2 kgf.m, 20.25 ~ 23.14 lbf.ft)

8. Connect brake vacuum hose.
9. Connect PCV hose.
10. Connect water hoses to ETC.
11. Install ETC bracket.

**Tightening torque**

15.68 ~ 25.48 Nm (1.6 ~ 2.6 kgf.m, 11.57 ~ 18.80 lbf.ft)

12. Connect ETC connector and knock sensor connector.
13. Connect PCSV connector, MAP sensor connector, and PCSV hose.
14. Connect RH injector connector and ignition coil connector.
15. Connect RH oxygen sensor connector.
16. Install air cleaner upper cover and intake hose.
17. Connect AFS (A) and breather hose.

**EXHAUST MANIFOLD**

1. Install new gasket and exhaust manifold.

**Tightening torque**

39.2 ~ 44.1 Nm (4.0 ~ 4.5 kgf.m, 28.92 ~ 32.53 lbf.ft)

2. Install heat protector.

**Tightening torque**

16.66 ~ 21.56 Nm (1.7 ~ 2.2 kgf.m, 12.30 ~ 15.91 lbf.ft)

3. Install front muffler.

**Tightening torque**

39.2 ~ 58.8 N.m (4.0 ~ 6.0 kgf.m, 28.92 ~ 43.37 lbf.ft)

4. Connect oxygen sensor connector.
5. Install under cover.