

2001 Chevrolet S10 Pickup

2000-01 SUSPENSION Front - 4WD Torsion Bar - "T" Series

2000-01 SUSPENSION

Front - 4WD Torsion Bar - "T" Series

DESCRIPTION

Independent front suspension consists of upper and lower control arms with steering knuckle mounted between ball joints. See **Fig. 1**. Shock absorbers fit between lower control arm and frame. A stabilizer bar is mounted to frame side rails and connected to lower control arms.

Torsion bars are used in place of coil springs. Front of torsion bar attaches to lower control arm. Rear of torsion bar attaches to adjustable arm at torsion bar support crossmember. Adjustments to trim height are made here.

2001 Chevrolet S10 Pickup

2000-01 SUSPENSION Front - 4WD Torsion Bar - "T" Series

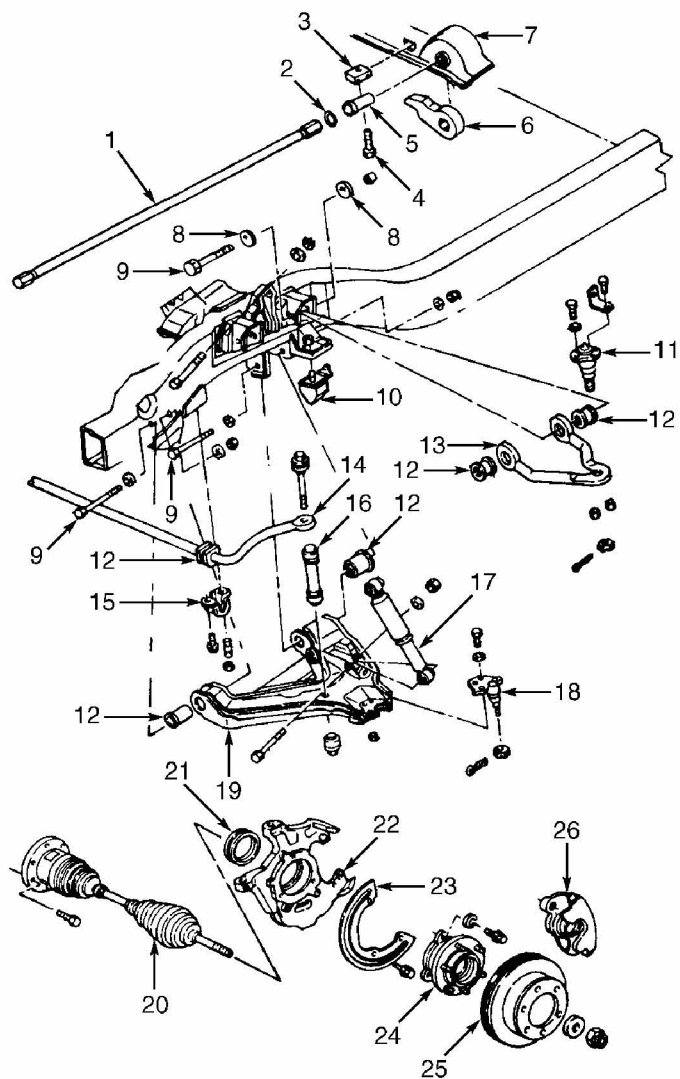

- | | |
|-----------------------------|----------------------------|
| 1. Torsion Bar | 14. Stabilizer Bar |
| 2. Seal | 15. Clamp |
| 3. Adjusting Nut | 16. Spacer |
| 4. Adjusting Bolt | 17. Shock Absorber |
| 5. Anchor Adapter | 18. Lower Ball Joint |
| 6. Adjusting Arm | 19. Lower Control Arm |
| 7. Support | 20. Drive Axle |
| 8. Alignment Adjustment Cam | 21. Grease Seal |
| 9. Pivot Bolt | 22. Steering Knuckle |
| 10. Bumper | 23. Splash Shield |
| 11. Upper Ball Joint | 24. Hub & Bearing Assembly |
| 12. Bushing | 25. Rotor |
| 13. Upper Control Arm | 26. Brake Caliper |

G92H21896

Fig. 1: Exploded View Of Front Suspension
Courtesy of GENERAL MOTORS CORP.

ADJUSTMENTS & INSPECTION

WHEEL ALIGNMENT

2001 Chevrolet S10 Pickup

2000-01 SUSPENSION Front - 4WD Torsion Bar - "T" Series

NOTE: See appropriate SPECIFICATIONS & PROCEDURES article in WHEEL ALIGNMENT.

FRONT WHEEL BEARINGS

Adjustment

1. Raise vehicle and support with safety stands. Remove dust cap from wheel hub. Remove cotter pin.
2. Tighten hub nut to 12 ft. lbs. (16 N.m) while rotating wheel by hand. This will help seat wheel bearings.
3. Loosen wheel hub nut no more than 1/2 flat, and retighten by hand. Back nut off until hole in spindle aligns with a slot in nut.
4. Install a NEW cotter pin. Ensure cotter pin ends do not interfere with dust cap. Measure hub end play. Correct endplay is 0.001-0.005" (0.03-0.13 mm).

RIDE HEIGHT

NOTE: See appropriate SPECIFICATIONS & PROCEDURES article in WHEEL ALIGNMENT.

UPPER BALL JOINT CHECKING

NOTE: Replace ball joint rubber grease seal if cut or damaged.

1. Raise and support vehicle with jackstand under lower control arm, near lower ball joint. Ensure upper control arm bumper does not contact frame. Place dial indicator against lower part of wheel rim. Push in on bottom of tire while pulling outward at top. Read dial indicator, then reverse push/pull procedure.
2. If lateral (horizontal) deflection exceeds .125" (3.18 mm), replace ball joint. With ball joint disconnected from steering knuckle, try to rotate ball joint by finger pressure. If ball joint can be rotated by finger pressure, replace ball joint.

LOWER BALL JOINT CHECKING

NOTE: Replace ball joint rubber grease seal if cut or damaged.

Raise and support vehicle with jackstand under lower control arm, near lower ball joint. Place a dial indicator on spindle hub. Pry wheel between lower control arm and outer race to measure vertical movement. Note dial indicator reading. If reading exceeds .125" (3.18 mm), replace loose ball joint.

REMOVAL & INSTALLATION

CAUTION: When battery is disconnected, vehicle computer and memory systems may lose memory data. Driveability problems may exist until computer systems have completed a relearn cycle. See **COMPUTER RELEARN PROCEDURES** article in **GENERAL INFORMATION** before disconnecting battery.

WHEEL HUB & BEARINGS

Removal

1. Raise and support vehicle. Unload tension on torsion bar. See **TORSION BAR**. Remove wheel and tire assembly. Apply brake pedal. Remove axle shaft nut and washer. Remove rotor. See **Fig. 1**. Using brass drift and hammer, disengage axle shaft from wheel hub and bearing.

NOTE: Darkened areas on bearing assembly are caused by heat treatment process and do not indicate a need for replacement.

2. Remove wheel speed sensor. Remove wheel hub and bearing from steering knuckle. Remove splash shield and bearing seal.

Installation

1. To install NEW wheel hub stud, lubricate hub bore and install stud. Place 4 washers onto stud and install stud nut with flat side to washers. Tighten stud nut to draw stud into hub bore. Remove nut and washers. Install hub and bearing assembly onto axle shaft.
2. To complete installation, reverse removal procedure. Tighten bolts and nuts to specification. See **TORQUE SPECIFICATIONS** . Depress brake pedal several times to extend caliper piston after installation.

STEERING KNUCKLE

Removal

1. Raise and support vehicle. Unload torsion bar tension. See **Fig. 2**. See **TORSION BAR**. Count exact number of tool turns for reassembly reference. Slide, but DO NOT remove, torsion bar forward.
2. Remove wheel and tire assembly. Remove wheel hub and bearing. Remove cotter pin and retaining nut from outer tie rod end. Using Ball Joint Separator (J-24319-B), remove outer tie rod end from steering knuckle.

2001 Chevrolet S10 Pickup

2000-01 SUSPENSION Front - 4WD Torsion Bar - "T" Series

3. Remove wheel speed sensor and brake hose bracket from upper control arm. Remove cotter pin and retaining nut from upper ball joint. Using a prybar, pry upper control arm upward. Using a hammer, strike steering knuckle around ball joint to remove ball joint. Remove upper ball joint from steering knuckle.
4. Remove cotter pin and retaining nut from lower ball joint. Using Ball Joint Separator (J-43631), disconnect lower ball joint from steering knuckle. Remove steering knuckle.

Installation

1. Install NEW steering knuckle grease seal into steering knuckle. Install spacer (if equipped). Install steering knuckle onto upper and lower ball joint studs.

CAUTION: When installing upper and lower ball joint stud nuts, tighten nut to align cotter pin hole. Do not tighten ball joint stud nuts more than an additional 1/6 turn to align cotter pin hole. Complete tightening of ball joint stud nuts with vehicle at proper ride height.

2. Install ball joint stud nuts and cotter pins. Install drive axle (if removed). Install tie rod end onto steering knuckle. Install tie rod end stud nut and cotter pin. Install hub and bearing assembly onto axle shaft and into steering knuckle.
3. To complete installation, reverse removal procedure. Tighten bolts and nuts to specification. See **TORQUE SPECIFICATIONS** . Lower vehicle. Check wheel alignment and adjust ride height. See appropriate **SPECIFICATIONS & PROCEDURES** article in **WHEEL ALIGNMENT**.

2001 Chevrolet S10 Pickup

2000-01 SUSPENSION Front - 4WD Torsion Bar - "T" Series

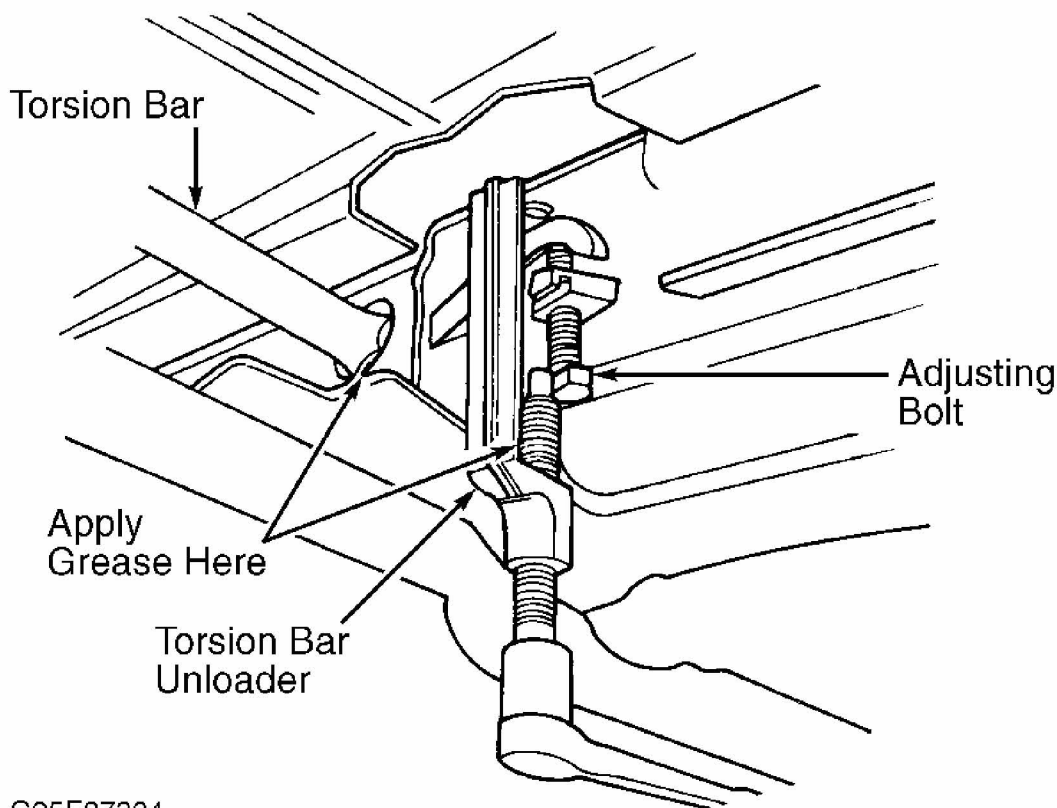

G95E27304

Fig. 2: Unloading Torsion Bar Tension
Courtesy of GENERAL MOTORS CORP.

SHOCK ABSORBERS

Removal

Raise and support vehicle. Remove wheel and tire assembly. Remove shock absorber retaining bolt and nut from lower control arm. Remove shock absorber retaining bolt and nut from frame. Remove shock absorber from vehicle.

Installation

To install, reverse removal procedure. Tighten bolts and nuts to specification. See **TORQUE SPECIFICATIONS**.

STABILIZER BAR

Removal

NOTE: Keep right and left side stabilizer bar components separate for installation in original locations.

2001 Chevrolet S10 Pickup

2000-01 SUSPENSION Front - 4WD Torsion Bar - "T" Series

Raise and support vehicle. Remove wheel and tire assembly. Remove fasteners and separate stabilizer bar from lower control arm. Remove stabilizer bar. Remove stabilizer bar bushings. Replace bushings if deformed or deteriorated. Replace stabilizer bar and clamps if excessive worn or damaged.

Installation

To install, reverse removal procedure. Ensure split in bushing faces toward front of vehicle. Tighten bolts and nuts to specification. See **TORQUE SPECIFICATIONS**. Lower vehicle. Adjust ride height and check wheel alignment. See appropriate SPECIFICATIONS & PROCEDURES article in WHEEL ALIGNMENT.

UPPER BALL JOINT

Removal

1. Raise and support vehicle under lower control arms. Remove wheel and tire assembly. Unload tension on torsion bar. See **TORSION BAR**. Disconnect wheel speed sensor and brake hose from upper control arm. Using a prybar, pry upper control arm upward. Using a hammer, strike steering knuckle around ball joint to remove ball joint. Remove upper ball joint from steering knuckle.
2. Drill a 1/8" (3.18 mm) diameter by 1/4" (6.35 mm) deep hole in ball joint retaining rivets. Drill off rivet heads with a 1/2" (12.7 mm) drill bit. Drive out rivets with a hammer and small punch. Remove ball joint.

Installation

CAUTION: When installing upper ball joint stud nut, tighten nut to align cotter pin hole. Do not tighten ball joint stud nut more than an additional 1/6 turn to align cotter pin hole. Complete tightening of upper ball joint stud nut with vehicle at proper riding height specification.

To install, reverse removal procedure. Use NEW nuts and bolts to install ball joint into upper control arm. Lubricate NEW ball joint. Tighten bolts and nuts to specification. See **TORQUE SPECIFICATIONS**. Lower vehicle. Check ride height and adjust wheel alignment. See appropriate SPECIFICATIONS & PROCEDURES article in WHEEL ALIGNMENT.

LOWER BALL JOINT

Removal

1. Raise and support vehicle under lower control arms. Remove wheel. Unload tension on torsion bar. See **TORSION BAR**. Remove wheel drive shaft.
2. Drill a 1/8" (3.18 mm) diameter by 1/4" (6.35 mm) deep hole in ball joint retaining

2001 Chevrolet S10 Pickup

2000-01 SUSPENSION Front - 4WD Torsion Bar - "T" Series

rivets. Drill off rivet heads with a 1/2" (12.7 mm) drill bit. Using a 5/16" (8 mm) drill bit, drill through 2/3 of the length of rivet shank. Drive out rivet with a 5/16" (8 mm) punch. Remove ball joint.

Installation

CAUTION: When installing lower ball joint stud nut, tighten nut to align cotter pin hole. Do not tighten ball joint stud nut more than an additional 1/6 turn to align cotter pin hole. Complete tightening of lower ball joint stud nut with vehicle at proper riding height specification.

To install, reverse removal procedure. Use NEW nuts and bolts to install ball joints into lower control arm. Lubricate NEW ball joint. Tighten bolts and nuts to specification. See **TORQUE SPECIFICATIONS** . Lower vehicle. Check wheel alignment and adjust ride height. See appropriate SPECIFICATIONS & PROCEDURES article in WHEEL ALIGNMENT.

UPPER CONTROL ARM

Removal

1. Raise and support vehicle under lower control arms. Remove wheel. Remove shock absorber. Using a prybar, pry upper control arm upward. Using a hammer, strike steering knuckle around ball joint to remove ball joint. Remove upper ball joint from steering knuckle.
2. Mark alignment adjustment cams for reassembly reference. Remove upper control arm pivot bolts, cams/washers and nuts. Remove upper control arm from vehicle. See **Fig. 3**. Replace bushings and/or bumper as necessary.

Installation

1. If upper control arm bumper is deteriorated or damaged, install NEW bumper. Mount upper control arm on vehicle. Install pivot bolts, alignment adjustment cams and NEW pivot bolt nuts.

CAUTION: When installing upper ball joint stud nut, tighten nut to align cotter pin hole. Do not tighten ball joint stud nut more than an additional 1/6 turn to align cotter pin hole. Complete tightening of upper ball joint stud nut with vehicle at proper riding height specification.

2. Ensure pivot bolt heads are facing inward. Connect steering knuckle to upper ball joint studs. To complete installation, reverse removal procedure. Tighten bolts and nuts to specification. See **TORQUE SPECIFICATIONS** .

- Lower vehicle. Check wheel alignment and adjust ride height. See appropriate SPECIFICATIONS & PROCEDURES article in WHEEL ALIGNMENT. Complete tightening of upper control arm pivot bolts and nuts with vehicle at proper ride height.

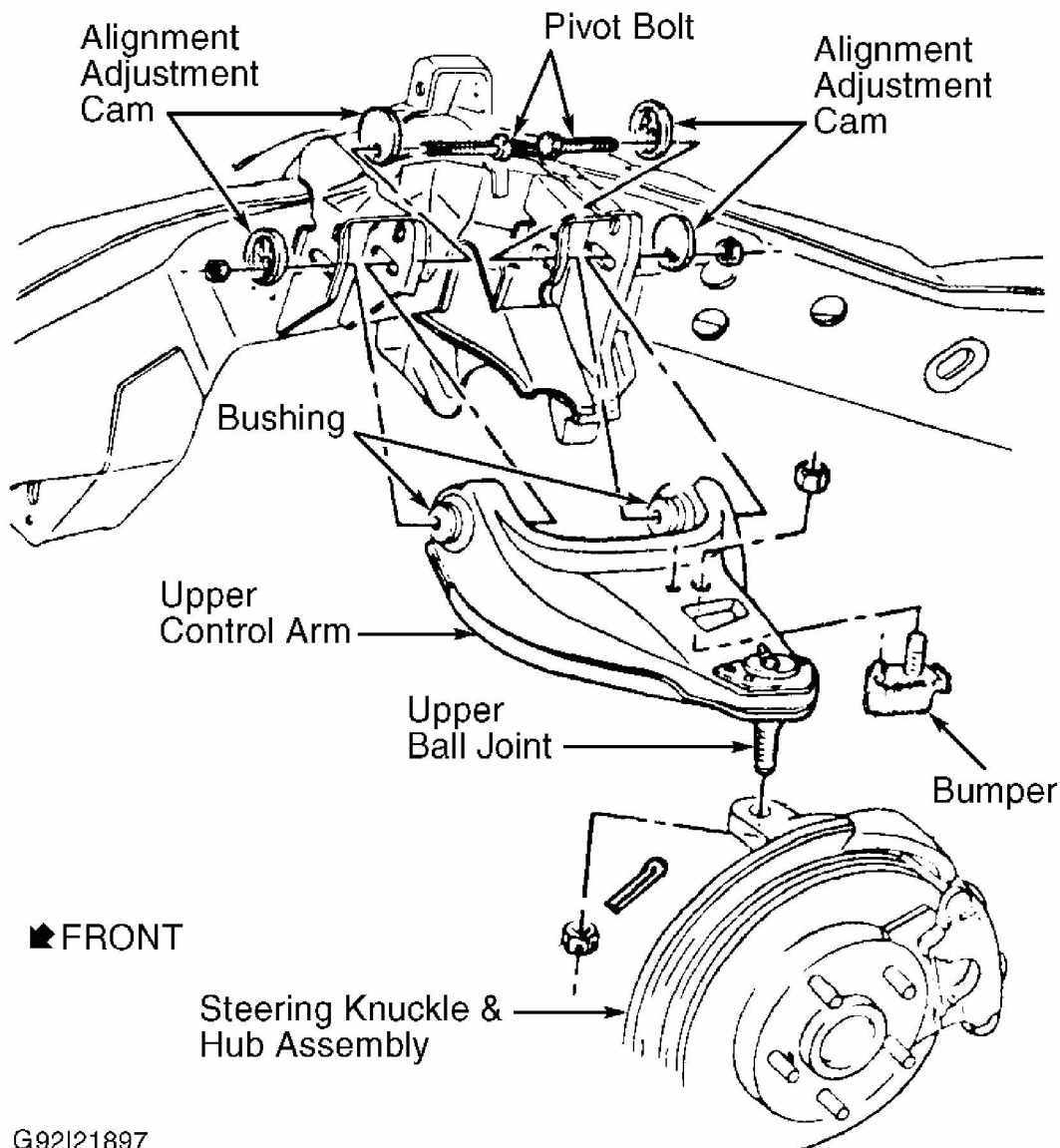

G92121897

Fig. 3: Exploded View Of Upper Control Arm
 Courtesy of GENERAL MOTORS CORP.

UPPER CONTROL ARM BUSHINGS

Bushing Replacement

- Remove upper control arm from vehicle. See UPPER CONTROL ARM. Place upper control arm in soft-jaw vise.

2. Using Control Arm Bushing Service Set (J-21474-01), press bushings out of upper control arm. See **Fig. 4**.
3. Install NEW bushings into upper control arm using control arm bushing service set.
4. Ensure bushings are properly seated in upper control arm. Install upper control arm. See **UPPER CONTROL ARM**.

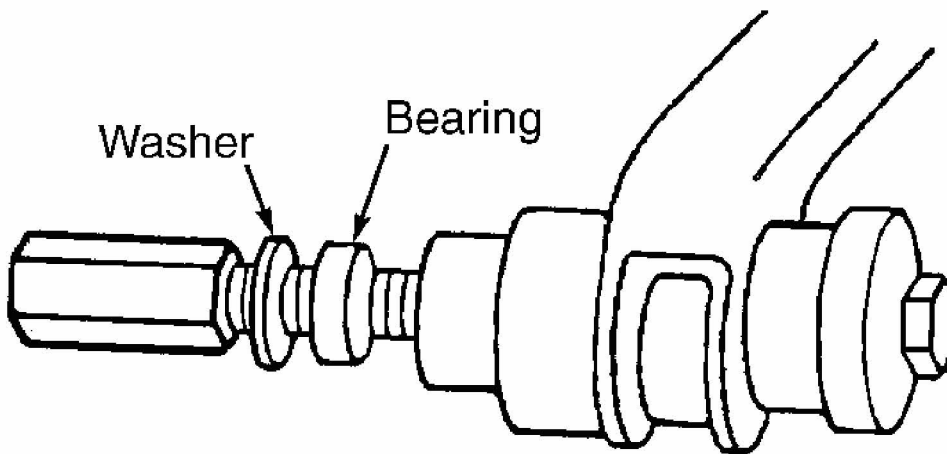

REMOVING UPPER-CONTROL ARM BUSHING

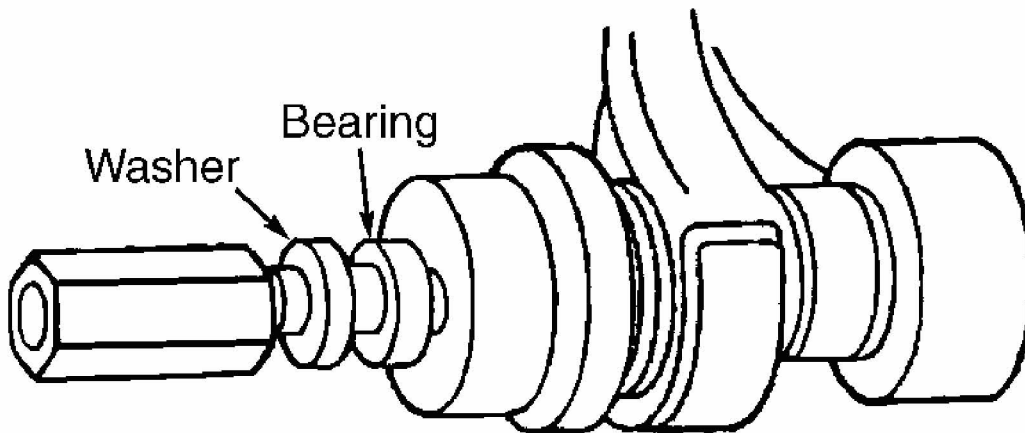

INSTALLING UPPER-CONTROL ARM BUSHING

G00030563

2001 Chevrolet S10 Pickup

2000-01 SUSPENSION Front - 4WD Torsion Bar - "T" Series

LOWER CONTROL ARM

Removal

1. Raise and support vehicle. Unload torsion bar tension. See **TORSION BAR**. See **Fig. 2**. Count exact number of tool turns for reassembly reference. Slide torsion bar forward to remove adjuster arm. Remove wheel and tire assembly.
2. Remove drive axle nut. Remove steering linkage shield. Remove stabilizer bar from vehicle. See **STABILIZER BAR**. Remove shock absorber from vehicle. See **SHOCK ABSORBERS**. Using brass drift and hammer, disengage axle shaft from hub and bearing. Remove rotor.
3. Remove wheel speed sensor electrical connector. Remove outer tie rod cotter pin and retaining nut. Using Tie Rod Puller (J-24319-B), remove outer tie rod from steering knuckle. Remove upper ball joint cotter pin and retaining nut. Using a prybar, pry upper control arm upward. Using a hammer, strike steering knuckle around ball joint to remove ball joint. Remove upper ball joint from steering knuckle. Remove lower ball joint cotter pin and retaining nut. Using Ball Joint Separator (J-43631), separate lower ball joint from steering knuckle. Remove steering knuckle.
4. Remove lower control arm pivot bolts, nuts and washers. Remove lower control arm from vehicle. See **Fig. 1**. Replace bushings and/or bumper as necessary.

Installation

1. To install, reverse removal procedure. Install front leg of lower control arm onto vehicle, then rear leg. Install lower control arm pivot bolts, washers and NEW nuts, with bolt heads facing rearward.

CAUTION: When installing upper ball joint stud nut, tighten nut to align cotter pin hole. Do not tighten ball joint stud nut more than an additional 1/6 turn to align cotter pin hole. Complete tightening of upper ball joint stud nut with vehicle at proper riding height specification.

2. Tighten bolts and nuts to specification. See **TORQUE SPECIFICATIONS**. Lower vehicle. Check wheel alignment and adjust ride height. See appropriate **SPECIFICATIONS & PROCEDURES** article in **WHEEL ALIGNMENT**. Complete tightening of lower control arm pivot bolts and nuts with vehicle at proper riding height specification.

LOWER CONTROL ARM BUSHINGS

Removal

Remove lower control arm. See **LOWER CONTROL ARM**. Place lower control arm in a soft-jawed vise. Press bushings out of lower control arm using a washer, bearing and Control

Arm Bushing Service Set (J-21474). See **Fig. 5**.

Installation

To install, reverse removal procedure. Press in bushings until properly seated. Install lower control arm. See **LOWER CONTROL ARM**.

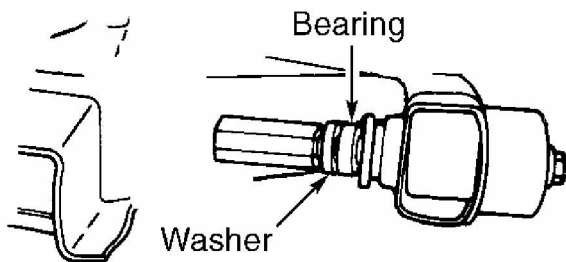

REMOVING LOWER FRONT BUSHING

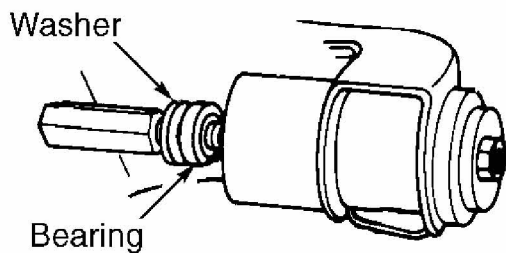

INSTALLING LOWER FRONT BUSHING

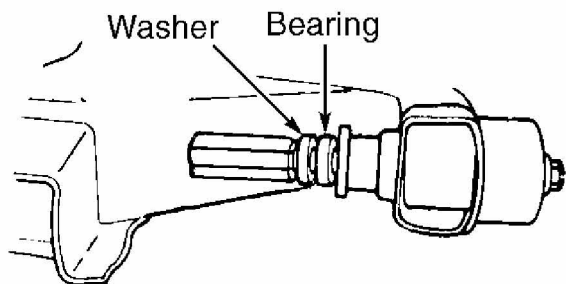

REMOVING LOWER REAR BUSHING

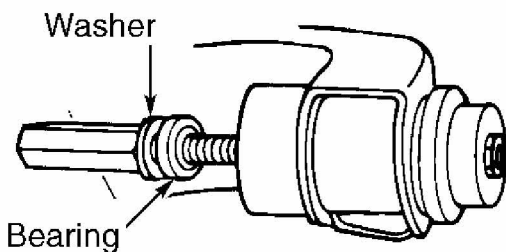

INSTALLING LOWER REAR BUSHING

Fig. 5: Replacing Lower Control Arm Bushings
Courtesy of GENERAL MOTORS CORP.

TORSION BARS & SUPPORT

Removal

1. Raise and support vehicle. Remove wheel and tire assembly. Unload torsion bar tension. See **Fig. 2**. Mark adjusting bolt setting. Using Torsion Bar Unloader (J-36202), increase tension on adjusting arm. Remove torsion bar adjusting bolt, counting number of turns for reassembly reference.
2. Remove torsion bar adjusting nut. Slowly relieve torsion bar tension. Remove unloading tool. Slide torsion bar forward. Remove torsion bar adjusting arm. Remove support mounting bolts, nuts and washers. Remove support retainer, spacer and rubber insulator. See **Fig. 6**.
3. Remove torsion bar support. Slide torsion bar rearward and remove from lower control arm.
4. Inspect torsion bars, adjusting arms, retainers, rubber insulators and support for bend, cracks, deterioration or damage. Check adjusting bolt and nut for damage or stripped threads, replace as necessary.

Installation

1. Install torsion bar rubber insulators, spacer and support retainer onto support. Install support assembly onto frame, slightly behind mounting holes.
2. Install adjusting arm and seal onto torsion bar. Slide torsion bar into lower control arm in original position. Slide torsion bar support forward, engaging rear of torsion bar in support. Install support mounting bolts, nuts and washers. Tighten bolts and nuts to specification. See **TORQUE SPECIFICATIONS** .
3. Install adjusting bolt and nut on each torsion bar. Add tension to torsion bar with Torsion Bar Unloader (J-36202). Ensure adjusting bolt is positioned to setting marked before removal. Release tension on unloading tool until tension is taken up by adjusting bolt. Remove unloading tool. Lower vehicle. Check wheel alignment and adjust ride height. See appropriate SPECIFICATIONS & PROCEDURES article in WHEEL ALIGNMENT.

2001 Chevrolet S10 Pickup

2000-01 SUSPENSION Front - 4WD Torsion Bar - "T" Series

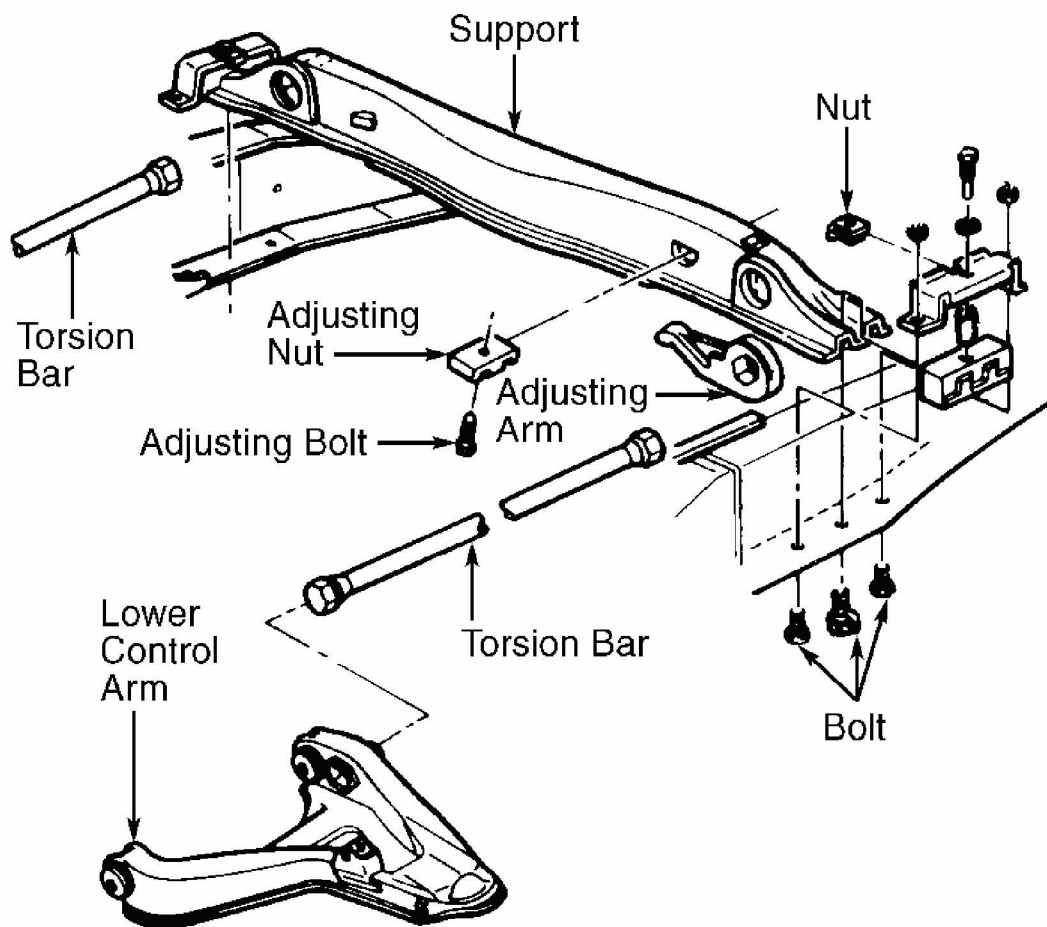

G90E04806

Fig. 6: Exploded View Of Torsion Bar & Support Assembly
 Courtesy of GENERAL MOTORS CORP.

TORQUE SPECIFICATIONS

TORQUE SPECIFICATIONS

Application	Ft. Lbs. (N.m)
Ball Joint-To-Control Arm Nut ⁽¹⁾	17 (23)
Ball Joint-To-Steering Knuckle Nut ^{(1) (2)}	
Lower	79 (107)
Upper	61 (83)
Drive Axle Shaft Nut	103 (140)
Hub & Bearing/Shield-To-Steering Knuckle Bolt	77 (104)
Lower Control Arm-To-Frame Pivot Bolt ^{(1) (3)}	81 (110)
	81 (110)

2001 Chevrolet S10 Pickup

2000-01 SUSPENSION Front - 4WD Torsion Bar - "T" Series

Lower Control Arm-To-Frame Pivot Bolt Nut ^{(1) (4) (3)}	
Shock Absorber Nut ⁽⁵⁾	54 (73)
Stabilizer Bar Clamp-To-Frame Bolt	48 (65)
Stabilizer Bar-To-Lower Control Arm Bolt	11 (15)
Tie Rod End-To-Steering Knuckle Nut	39 (53)
Torsion Bar Retainer-To-Support Link Nut	
Lower	37 (50)
Upper	48 (65)
Upper Control Arm-To-Frame Pivot Bolt Nut ⁽¹⁾	85 (115)
Upper Control Arm Bumper	20 (27)
Wheel Lug Nut	95 (129)

(1) Complete tightening of bolts and/or nuts with vehicle at proper riding height specification.

(2) Tighten nut to align cotter pin hole. DO NOT tighten nut more than an additional 1/6 turn to align cotter pin hole.

(3) Install upper/rear bolt with nut facing rear of vehicle. Install lower/front bolt with nut facing front of vehicle.

(4) Use NEW nuts during reassembly.

(5) Install both bolts with nuts facing rear of vehicle.