

2007 Ford Focus S

2007 ENGINE Engine - 2.0L and 2.3L - Focus

2007 ENGINE

Engine - 2.0L and 2.3L - Focus

SPECIFICATIONS

GENERAL SPECIFICATIONS

GENERAL SPECIFICATIONS

Item	Specification
Engine	
Displacement	2.0L
No. of cylinders	4
Bore/stroke	87.5/83.1
Firing order	1-3-4-2
Oil pressure (hot @ 2,000 RPM)	200-268 kPa (29-39 psi)
Belt tension	Refer to ACCESSORY DRIVE article.
Oil capacity	3.9L + 0.38L (4.1 qt + 0.4 qt) with filter
Cylinder Block	
Cylinder bore diameter	87.5-87.53 mm (3.444-3.445 in)
Cylinder bore maximum out-of-round	0.008 mm (0.0003 in)
Main bearing bore diameter	57.020-57.038 mm (2.244-2.245 in)
Head gasket surface flatness	0.1 mm/general 0.05 mm/200 x 200 (0.004 in/general) (0.0019 in/7.87 x 7.87)
Piston	
Diameter (1)	87.5-87.51 mm (3.444-3.445 in)
Diameter (2)	87.51-87.52 mm (3.4452-3.4456 in)
Diameter (3)	87.52-87.53 mm (3.444-3.446 in)
Piston-to-bore clearance	0.025-0.045 mm (0.0009-0.0017 in)
Ring groove width - top	1.203-1.205 mm (0.0473-0.0474 in)
Ring groove width - 2nd	1.17-1.19 mm (0.0460-0.0468 in)
Ring groove width - oil	2.501-2.503 mm (0.0984-0.0985 in)
Piston skirt coating thickness	0.008-0.020 mm (0.0003-0.0007 in)
Piston Pin	
Diameter	20.995-21.0 mm (0.8266-0.8268 in)
Length	59.6-60.4 mm (2.346-2.377 in)
Piston-to-pin clearance	0.008-0.016 mm (0.0003-0.0006 in)
Pin-to-rod clearance	Press fit
Cylinder Head	
Valve lift @ zero lash (exhaust)	7.7 mm (0.30 in)
Valve lift @ zero lash (intake)	8.8 mm (0.35 in)
Valve guide diameter	5.509-5.539 mm (0.216-0.218 in)

2007 Ford Focus S

2007 ENGINE Engine - 2.0L and 2.3L - Focus

Valve seat width - intake/exhaust	0.99-1.84 mm (0.038-0.072 in)
Valve seat angle	45 degrees
Valve seat runout	0.075 mm (0.0029 in)
Valve lash adjuster bore diameter	31.00-31.03 mm (1.220-1.221 in)
Cam bore diameter	25.015-25.040 mm (0.984-0.985 in)
Valve	
Valve head diameter - intake	34.85-35.15 mm (1.372-1.383 in)
Valve head diameter - exhaust	29.85-30.15 mm (1.175-1.187 in)
Valve stem diameter - intake	5.470-5.485 mm (0.2153-0.2159 in)
Valve stem diameter - exhaust	5.465-5.480 mm (0.2151-0.2157 in)
Valve stem-to-guide clearance - intake	0.0027 mm (0.0001 in)
Valve stem-to-guide clearance - exhaust	0.0029 mm (0.00011 in)
Valve face runout	0.05 mm (0.001 in)
Valve face angle	45 degrees
Valve Spring - Compression Pressure	
Intake and exhaust (installed)	17.5 kg (38.667 lbs)
Intake (valve open) 8.9 mm (0.35 in) of lift	44 kg (97.032 lbs)
Exhaust (valve open) 7.4 mm (0.29 in) of lift	42 kg (93.338 lbs)
Free length	44.92 mm (1.768 in)
Assembled height	37.9 mm (1.492 in)
Crankshaft	
Main bearing journal diameter	51.980-52.000 mm (2.046-2.047 in)
Production repair	51.730-51.750 mm (2.036-2.037 in)
Main bearing clearance	0.019-0.035 mm (0.0007-0.0013 in)
Connecting rod journal diameter	49.980-50.000 mm (1.967-1.968 in)
Production repair	49.730-49.750 mm (1.957-1.958 in)
End play	0.22-0.43 mm (0.008-0.016 in)
Rings	
Width - top	1.17-1.185 mm (0.0460-0.0466 in)
Width - 2nd	1.197-1.199 mm (0.0471-0.0472 in)
Width - oil	2.38-2.45 mm (0.093-0.096 in)
Ring gap (in bore) - top	0.16-0.31 mm (0.006-0.012 in)
Ring gap (in bore) - 2nd	0.33-0.48 mm (0.012-0.018 in)
Ring gap (in bore) - oil	0.2-0.7 mm (0.007-0.027 in)
Valve Tappet	
Diameter	30.97-30.98 mm (1.2192-1.2196 in)
Tappet-to-valve clearance - intake	0.22- 0.28 mm (0.008-0.011 in)
Tappet-to-valve clearance - exhaust	0.27-0.33 mm (0.010-0.013 in)
Tappet-to-bore clearance	0.02-0.06 mm (0.0007-0.0023 in)
Camshaft	

2007 Ford Focus S

2007 ENGINE Engine - 2.0L and 2.3L - Focus

Lobe lift - intake	8.24999 mm (0.324 in)
Lobe lift - exhaust	7.80007 mm (0.307 in)
Runout (1) ^a	0.03 mm (0.001 in)
Thrust clearance	0.09-0.24 mm (0.003-0.009 in)
Journal diameter	24.96-24.98 mm (0.982-0.983 in)
Journal-to-bore clearance	0.035-0.080 mm (0.001-0.003 in)
Connecting Rod	
Bearing clearance	0.027-0.052 mm (0.001-0.002 in)
Bearing thickness	1.496-1.520 mm (0.058-0.059 in)
Crank bore diameter	53.025-53.045 mm (2.087-2.088 in)
Pin bore diameter	20.965-20.985 mm (0.825-0.826 in)
Length (center to center)	154.8 mm (6.094 in)
Side clearance	1.95-3.05 mm (0.076-0.120 in)
Axial clearance	0.14-0.36 mm (0.005-0.014 in)

^a No. 3 Journal - Supported by No. 1 and No. 5 journals.

GENERAL SPECIFICATIONS**GENERAL SPECIFICATIONS**

Item	Specification
Engine	
Displacement	2.3L
No. of cylinders	4
Bore/stroke	87.5/94.0
Firing order	1-3-4-2
Oil pressure (hot @ 2,000 RPM)	200-268 kPa (29-39 psi)
Belt tension	Refer to <u>ACCESSORY DRIVE</u> article.
Oil capacity	3.9L + 0.38L (4.1 qt + 0.4 qt) with filter
Cylinder Block	
Cylinder bore diameter	87.5-87.53 mm (3.444-3.446 in)
Cylinder bore maximum out-of-round	0.008 mm (0.0003 in)
Main bearing bore diameter	57.020-57.038 mm (2.244-2.245 in)
Head gasket surface flatness	0.1 mm/general 0.05 mm/200 x 200 (0.003 in./general) (0.0019 in./7.87 x 7.87)
Piston	
Diameter (1)	87.5-87.51 mm (3.444-3.445 in)
Diameter (2)	87.51-87.52 mm (3.4452-3.4456 in)
Diameter (3)	87.52-87.53 mm (3.4456-3.4460 in)
Piston-to-bore clearance	0.025-0.045 mm (0.0009-0.0017 in)
Ring groove width - top	1.203-1.205 mm (0.0473-0.0474 in)

2007 Ford Focus S

2007 ENGINE Engine - 2.0L and 2.3L - Focus

Ring groove width - 2nd	1.17-1.19 mm (0.0460-0.0468 in)
Ring groove width - oil	2.501-2.503 mm (0.0984-0.0985 in)
Piston skirt coating thickness	0.008-0.020 mm (0.0003-0.0007 in)
Piston Pin	
Diameter	20.995-21.0 mm (0.8265-0.8267 in)
Length	59.6-60.4 mm (2.346-2.377 in)
Piston-to-pin clearance	0.008-0.016 mm (0.0003-0.0006 in)
Pin-to-rod clearance	Press fit
Cylinder Head	
Valve lift @ zero lash (exhaust)	7.4 mm (0.30 in)
Valve lift @ zero lash (intake)	7.9 mm (0.31 in)
Valve guide diameter	5.509-5.539 mm (0.216-0.218 in)
Valve seat width - intake/exhaust	0.99-1.84 mm (0.038-0.072 in)
Valve seat angle	45 degrees
Valve seat runout	0.075 mm (0.0029 in)
Valve lash adjuster bore diameter	31.00-31.03 mm (1.220-1.221 in)
Cam bore diameter	25.015-25.040 mm (0.984-0.985 in)
Valve	
Valve head diameter - intake	34.85-35.15 mm (1.372-1.383 in)
Valve head diameter - exhaust	29.85-30.15 mm (1.175-1.187 in)
Valve stem diameter - intake	5.470-5.485 mm (0.2153-0.2159 in)
Valve stem diameter - exhaust	5.465-5.480 mm (0.2151-0.2157 in)
Valve stem-to-guide clearance - intake	0.0027 mm (0.00010 in)
Valve stem-to-guide clearance - exhaust	0.0029 mm (0.00011 in)
Valve face runout	0.05 mm (0.0019 in)
Valve face angle	45 degrees
Valve Spring - Compression Pressure	
Intake and exhaust (installed)	17.5 kg (38.667 lb)
Intake (valve open) 8.9 mm (0.35 in) of lift	44 kg (97.032 lb)
Exhaust (valve open) 7.4 mm (0.29 in) of lift	42 kg (93.338 lb)
Free length	44.92 mm (1.768 in)
Assembled height	37.9 mm (1.492 in)
Crankshaft	
Main bearing journal diameter	51.980-52.000 mm (2.046-2.047 in)
Production repair	51.730-51.750 mm (2.036-2.037 in)
Main bearing clearance	0.019-0.035 mm (0.0007-0.0013 in)
Connecting rod journal diameter	49.980-50.000 mm (1.967-1.968 in)
Production repair	49.730-49.750 mm (1.957-1.958 in)
End play	0.22-0.43 mm (0.008-0.016 in)
Rings	
Width - top	1.17-1.185 mm (0.0460-0.0466 in)

2007 Ford Focus S

2007 ENGINE Engine - 2.0L and 2.3L - Focus

	1.197-1.199 mm (0.0471-0.0472 in)
Width - oil	2.38-2.45 mm (0.093-0.096 in)
Ring gap (in bore) - top	0.16-0.31 mm (0.006-0.012 in)
Ring gap (in bore) - 2nd	0.33-0.48 mm (0.012-0.018 in)
Ring gap (in bore) - oil	0.2-0.7 mm (0.007-0.027 in)
Valve Tappet	
Diameter	30.97-30.98 mm (1.2192-1.2196 in)
Tappet-to-valve clearance - intake	0.22- 0.28 mm (0.008-0.011 in)
Tappet-to-valve clearance - exhaust	0.27-0.33 mm (0.010-0.013 in)
Tappet-to-bore clearance	0.02-0.06 mm (0.0007-0.0023 in)
Camshaft	
Lobe lift - intake	8.24999 mm (0.324 in)
Lobe lift - exhaust	7.80007 mm (0.307 in)
Runout (1) ^a	0.03 mm (0.001 in)
Thrust clearance	0.09-0.24 mm (0.003-0.009 in)
Journal diameter	24.96-24.98 mm (0.982-0.983 in)
Journal-to-bore clearance	0.035-0.080 mm (0.001-0.003 in)
Connecting Rod	
Bearing clearance	0.027-0.052 mm (0.001-0.002 in)
Bearing thickness	1.496-1.520 mm (0.058-0.059 in)
Crank bore diameter	53.025-53.045 mm (2.087-2.088 in)
Pin bore diameter	20.965-20.985 mm (0.825-0.826 in)
Length (center to center)	154.8 mm (6.094 in)
Side clearance	1.95-3.05 mm (0.076-0.120 in)
Axial clearance	0.14-0.36 mm (0.005-0.014 in)

^a No. 3 Journal - Supported by No. 1 and No. 5 journals.

GENERAL SPECIFICATIONS

GENERAL SPECIFICATIONS

Item	Specification
Motorcraft Metal Surface Cleaner ZC-21	WSE-M5B392-A
Silicone Gasket Remover ZC-30	-
Motorcraft Metal Surface Prep ZC-31	-
Silicone Gasket and Sealant TA-30	WSE-M4G323-A4
Motorcraft SAE 5W-20 Premium Synthetic Blend Motor Oil XO-5W20-QSP (US); Motorcraft SAE 5W-20 Super Premium Motor Oil CXO-5W20-LSP12 (Canada); or equivalent	WSS-M2C930-A

2007 Ford Focus S

2007 ENGINE Engine - 2.0L and 2.3L - Focus

Motorcraft Premium Gold Engine Coolant with Bittering Agent (US only) VC-7-B (US); CVC-7-A (Canada); or equivalent (yellow color)	WSS-M97B51-A1
Multi-Purpose Grease XG-4 and/or XL-5	ESB-M1C93-B
Thread Sealant with PTFE TA-24	WSK-M2G350-A2
High Temperature 4x4 Front Axle and Wheel Bearing Grease E8TZ-19590-A	ESA-M1C198-A
Silicone Brake Caliper Grease and Dielectric Compound XG-3-A	ESE-M1C17-A

TORQUE SPECIFICATIONS

TORQUE SPECIFICATIONS

Description	Nm	lb-ft	lb-in
A/C compressor mounting bolts	25	18	-
A/C manifold tube bolt	21	15	-
Accelerator cable bracket	10	-	89
Accelerator control snow shield	10	-	89
Accessory drive belt idler bolt	25	18	-
Accessory drive belt tensioner bolt	25	18	-
Air cleaner outlet tube clamps	4	-	35
Bellhousing-to-engine bolts	48	35	-
Bellhousing-to-engine stud bolt	48	35	-
Block heater (if equipped)	21	15	-
Camshaft bearing caps ^a	-	-	-
Camshaft sprocket bolt	72	53	-
Catalytic converter heat shield bolts	11	8	-
Catalytic converter nuts	55	41	-
Catalytic converter support bracket	47	35	-
Catalytic converter support bracket bolts	47	35	-
Catalytic converter-to-cylinder head nuts ^a	-	-	-
Catalytic converter-to-exhaust system nuts	47	35	-
Catalytic converter-to-muffler assembly nuts	47	35	-
Coil-on-plug retaining bolt	10	-	89
Coolant expansion tank bolt	10	-	89
Coolant outlet bolts	10	-	89
Coolant pump bolts	10	-	89
Coolant pump pulley bolts	20	15	-
Crankcase ventilation cover assembly bolts	10	-	89
Crankshaft oil seal retainer bolts ^a	-	-	-
Crankshaft position (CKP) sensor ^a	-	-	-

2007 Ford Focus S

2007 ENGINE Engine - 2.0L and 2.3L - Focus

Crankshaft pulley bolt ^a	-	-	-
Cylinder head bolts ^a	-	-	-
Cylinder head temperature (CHT) sensor	12	9	-
EGR tube nut	55	41	-
Engine front cover bolts ^a	-	-	-
Engine front cover-to-oil pan bolts ^a	-	-	-
Engine ground cable bolt	48	35	-
Engine lifting eye bolts	45	33	-
Engine plug bolt	20	15	-
Engine-to-bellhousing bolts	48	35	-
Engine-to-bellhousing stud bolt	48	35	-
Exhaust gas recirculation (EGR) valve assembly bolts	20	15	-
Flexplate bolts ^a	-	-	-
Flywheel bolts ^a	-	-	-
Front brake caliper	28	21	-
Fuel rail bolt	25	18	-
Generator B+ cable	8	-	71
Generator B+ cable retainer	25	18	-
Generator heat shield	18	13	-
Generator mounting bolts	25	18	-
Heated oxygen sensor (HO2S) and catalyst monitor sensor wire connector bracket nuts	25	18	-
Intake manifold bolts	18	13	-
Intermediate shaft bracket-to-engine bolt	40	30	-
Intermediate shaft mounting bracket bolt	25	18	-
Knock sensor (KS)	20	15	-
Motor mount bracket bolts	48	35	-
Motor mount nuts	90	66	-
Oil drain plug	28	21	-
Oil filter adapter bolts	25	18	-
Oil level indicator tube bolt(s)	10	-	89
Oil pan bolts ^a	-	-	-
Oil pan-to-bellhousing bolts ^a	-	-	-
Oil pressure sensor	15	11	-
Oil pump drive chain guide bolts (early build)	10	-	89
Oil pump drive chain tensioner shoulder bolts	10	-	89
Oil pump screen and cover assembly	10	-	89
Oil pump sprocket bolt	25	18	-
Oil pump-to-engine block bolts ^a	-	-	-
PSP tube bracket nut	11	8	-

2007 Ford Focus S

2007 ENGINE Engine - 2.0L and 2.3L - Focus

Power distribution harness eyelet nut	10	-	89
Power steering pressure (PSP) tube nut	65	48	-
Power steering pump mounting bolts	25	18	-
Pressure plate bolts	27	20	-
Radio interference capacitor bracket	10	-	89
Radio interference capacitor ground	10	-	89
Rear transaxle mounting nut	133	98	-
Spark plugs	12	9	-
Stabilizer bar	55	41	-
Starter B+ cable	12	9	-
Starter motor mounting bolts	25	18	-
Starter relay	5	-	44
Suspension arm ball joint bolt	63	46	-
Thermostat housing assembly bolts	10	-	89
Tie-rod end nut	40	30	-
Timing chain guide bolts	10	-	89
Timing chain tensioner bolts	10	-	89
Torque converter-to-flexplate nuts	35	26	-
Transaxle roll-restrictor bolts	48	35	-
Upper strut mount nuts	30	22	-
Valve cover bolts ^a	-	-	-
Valve cover retainers	10	-	89

^a See procedure for specification.

DESCRIPTION AND OPERATION

ENGINE

The 2.0L and 2.3L engines are 4 valve-per-cylinder, dual overhead camshaft engines. The engines use a coil-on-plug ignition system. The cylinder blocks are made of aluminum and the bearing caps are integrated into the ladder assemblies. An aluminum oil pan bolts to the bottom of the lower cylinder block and to the transmission to provide greater strength. The camshafts are mounted in the cylinder heads and act against valve tappets to open and close the valves. The camshafts are driven off the front of the cylinder head by one timing chain. The chain is driven by a sprocket that is located on the crankshaft. The piston assembly is an aluminum piston with a powdered metal cast iron connecting rod. The oil pump is driven by the crankshaft via a dedicated chain that is driven by the same sprocket that drives the timing chain.

DIAGNOSTIC TESTS

ENGINE

Refer to **ENGINE SYSTEM - GENERAL INFORMATION** article for basic mechanical concerns or refer to

the [INTRODUCTION - GASOLINE ENGINES](#) article for driveability concerns.

GENERAL PROCEDURES

VALVE CLEARANCE CHECK

1. Remove the valve cover. For additional information, refer to [Valve Cover](#).

CAUTION: Turn the engine clockwise only, and use the crankshaft bolt only.

NOTE: Measure each valve's clearance at base circle, with the lobe pointed away from the tappet, before removing the camshafts. Failure to measure all clearances prior to removing the camshafts will necessitate repeated removal and installation and wasted labor time.

2. Use a feeler gauge to measure each valve's clearance and record its location.

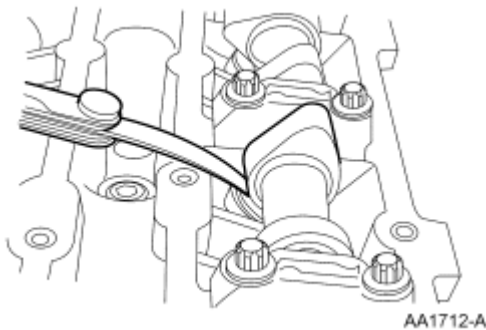

Fig. 1: Measuring Each Valve's Clearance Using A Feeler Gauge
Courtesy of FORD MOTOR CO.

NOTE: The number on the valve tappet only reflects the digits that follow the decimal. For example, a tappet with the number 0.650 has the thickness of 3.650 mm.

NOTE: The nominal desired mid-range clearance is:

- Intake: 0.25 mm (0.0095 in)
- Exhaust: 0.30 mm (0.0115 in)

Select tappets using this formula: tappet thickness = measured clearance + the base tappet thickness - most desirable thickness.

NOTE: The acceptable clearances after being fully installed are:

2007 Ford Focus S

2007 ENGINE Engine - 2.0L and 2.3L - Focus

- Intake: 0.22-0.28 mm (0.008-0.011 in)
- Exhaust: 0.27-0.33 mm (0.010-0.013 in)

3. Select the closest tappet size available and mark the installation location.
4. If any tappets do not measure within specifications, install new tappets in these locations. For additional information, refer to **Valve Train Components - Exploded View** and **Valve Tappets**.

BALANCE SHAFT BACKLASH

Special Tool(s)

SPECIAL TOOLS

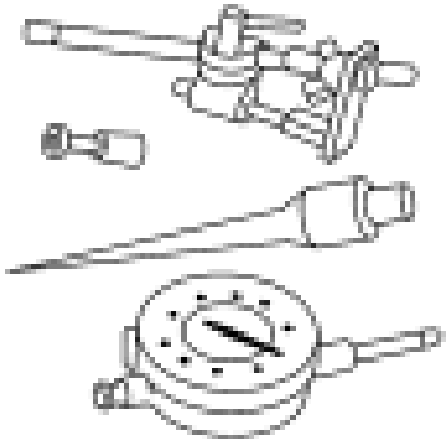
 <p>ST1214-A</p>	Dial Indicator Gauge with Holding Fixture 100-002 (TOOL-4201-C)
	Timing Peg, Crankshaft TDC 303-507



ST2638-A

1. Install the Crankshaft **TDC** Timing Peg and rotate the crankshaft slowly clockwise until the crankshaft balance weight is up against the Crankshaft **TDC** Timing Peg. The engine is now at Top Dead Center (TDC).

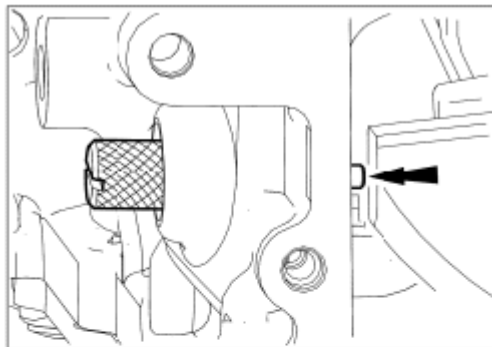

Fig. 2: Installing Crankshaft TDC Timing Peg

2. Mark the balancer unit and shafts on the top for reference that the balancer unit is at **TDC** .

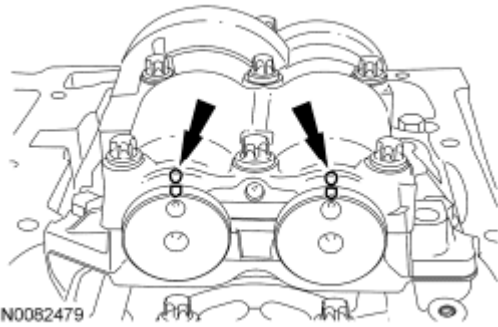

Fig. 3: Locating Balancer Unit And Shafts Mark

NOTE: Due to the precision interior construction of the balancer unit, it should not be disassembled.

3.

Remove the 4 bolts and the balancer unit.

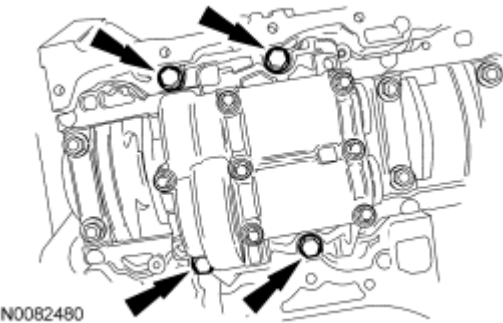

Fig. 4: Locating Balancer Unit Bolts

4. Remove the adjustment shims from the seat faces of the balancer unit.

NOTE: Visually inspect the balancer unit gear for damage and verify that the shaft turns smoothly. If there is any damage or malfunction, replace the balancer unit.

5.

Install the master adjustment shims (No. 50) on the seat faces of the balancer unit.

6. With the balancer unit shaft marks at the **TDC** position, slowly install the balancer unit to the cylinder block to avoid interference between the crankshaft drive gear and the balancer unit driven gear.

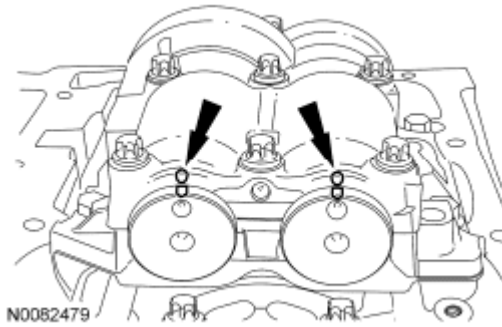

Fig. 5: Locating Balancer Unit And Shafts Reference Mark

7. Install the balancer unit bolts.
 - Tighten in the sequence shown in 2 stages.
 - Stage 1: Tighten to 25 Nm (18 lb-ft).
 - Stage 2: Tighten to 50 Nm (37 lb-ft).

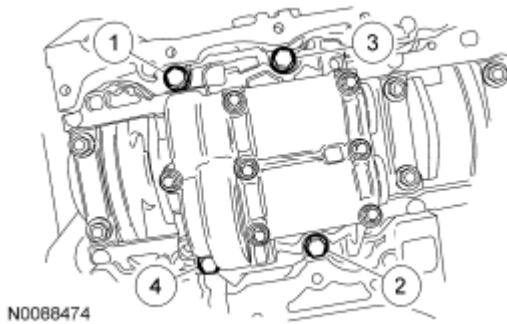

Fig. 6: Identifying Balancer Unit Bolts Tightening Sequence

8. Remove the Crankshaft TDC Timing Peg.
 - Rotate the crankshaft to confirm that there are no meshing problems between the balancer unit gear and the crankshaft gear.

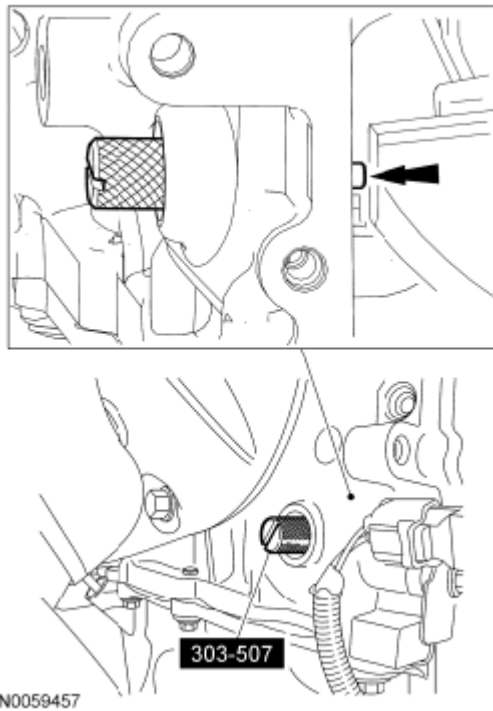

Fig. 7: Installing Crankshaft TDC Timing Peg

9. Install the Crankshaft **TDC** Timing Peg and rotate the crankshaft slowly clockwise until the crankshaft balance weight is up against the Crankshaft **TDC** Timing Peg.
 - Remove the Crankshaft **TDC** Timing Peg.

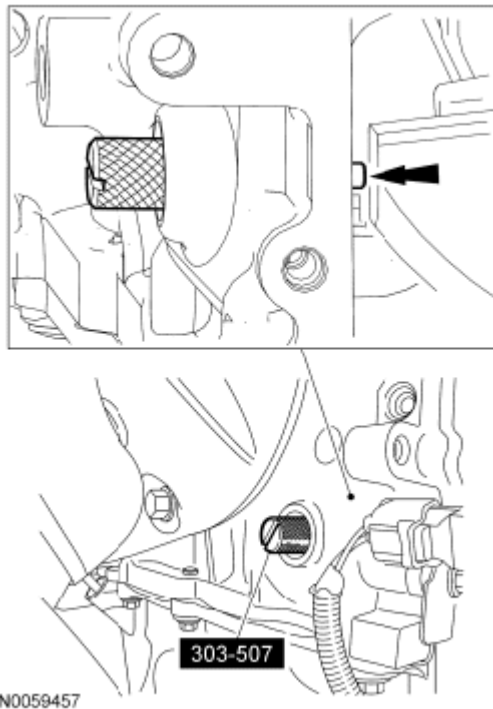

Fig. 8: Installing Crankshaft TDC Timing Peg

10. **NOTE:** Measure the backlash and verify that it is within specified range at all of the following 6 positions: 10 degrees, 30 degrees, 100 degrees, 190 degrees, 210 degrees and 280 degrees. It will be necessary to reset the measuring equipment between measurements.
- NOTE:** The measurement must be taken with the Dial Indicator Gauge with Holding Fixture, a 5-mm Allen wrench and worm clamp set up as shown. Mark the Allen wrench with a file 80 mm (3.149 in) above the driven gear shaft center. Make sure the worm clamp and Allen wrench are not touching the balance shaft housing.
- NOTE:** For an accurate measurement while measuring the gear backlash, insert a screwdriver as shown into the crankshaft No. 1 crankweight area and set both the rotation and the thrust direction with the screwdriver, using a prying action as shown.

Position the Dial Indicator Gauge with Holding Fixture as shown. Measure the gear backlash.

- Position the Dial Indicator Gauge with Holding Fixture (1) on the Allen wrench 80 mm (3.149 in) above the driven gear shaft center (2) on the balancer unit.
- Rotate the crankshaft clockwise and measure the backlash at all of the following 6 positions: 10 degrees, 30 degrees, 100 degrees, 190 degrees, 210 degrees and 280 degrees.

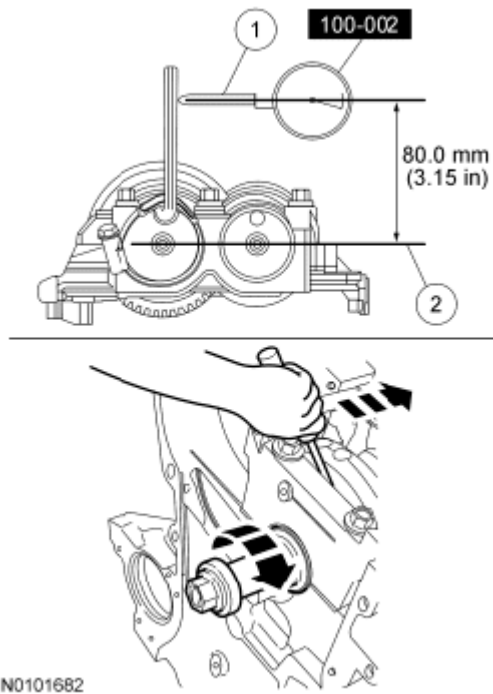

Fig. 9: Measuring Gear Backlash

- NOTE:** If maximum backlash exceeds 0.101 mm (0.003 in), install a new balancer unit.
- 11.

Using the backlash measurement, select the proper shims from the Adjustment Shim Selection Table.

- Remove the balancer unit from the cylinder block.
- Install the selected adjustment shims on the seat faces of the balancer unit.

2007 Ford Focus S

2007 ENGINE Engine - 2.0L and 2.3L - Focus

ADJUSTMENT SHIM SELECTION TABLE

Backlash mm (in)	Selection shim (No.)	Shim thickness mm (in)	Backlash mm (in)	Selection shim (No.)	Shim thickness mm (in)
0.516-0.528 (0.0203-0.0207)	15	1.15 (0.0452)	0.245-0.257 (0.0096-0.0101)	35	1.35 (0.0531)
0.502-0.514 (0.0197-0.0202)	16	1.16 (0.0456)	0.232-0.243 (0.0091-0.0095)	36	1.36 (0.535)
0.489-0.500 (0.0192-0.0196)	17	1.17 (0.0460)	0.218-0.230 (0.0085-0.0090)	37	1.37 (0.539)
0.475-0.487 (0.0137-0.0191)	18	1.18 (0.0464)	0.205-0.216 (0.0080-0.0085)	38	1.38 (0.0543)
0.452-0.473 (0.0131-0.0186)	19	1.19 (0.0468)	0.191-0.203 (0.0075-0.0079)	39	1.39 (0.0547)
0.448-0.460 (0.0176-0.0181)	20	1.20 (0.0472)	0.178-0.189 (0.0070-0.0074)	40	1.40 (0.0551)
0.435-0.446 (0.0171-0.0175)	21	1.21 (0.0476)	0.164-0.176 (0.0064-0.0069)	41	1.41 (0.0555)
0.421-0.433 (0.0165-0.0170)	22	1.22 (0.0480)	0.151-0.162 (0.0059-0.0063)	42	1.42 (0.0559)
0.408-0.419 (0.0160-0.0164)	23	1.23 (0.0484)	0.137-0.149 (0.0053-0.0058)	43	1.43 (0.0562)
0.394-0.406 (0.0155-0.0159)	24	1.24 (0.0488)	0.124-0.135 (0.0048-0.0053)	44	1.44 (0.0566)
0.331-0.392 (0.0130-0.0154)	25	1.25 (0.492)	0.110-0.122 (0.0043-0.0048)	45	1.45 (0.0570)
0.367-0.379 (0.0144-0.0149)	26	1.26 (0.0496)	0.097-0.108 (0.0038-0.0042)	46	1.46 (0.0574)
0.354-0.365 (0.0139-0.0143)	27	1.27 (0.0499)	0.083-0.095 (0.0032-0.0037)	47	1.47 (0.0578)
0.340-0.352 (0.0133-0.0138)	28	1.28 (0.0503)	0.070-0.081 (0.0027-0.0031)	48	1.48 (0.0582)
0.327-0.338 (0.0128-0.0133)	29	1.29 (0.0507)	0.056-0.068 (0.0022-0.0026)	49	1.49 (0.0586)
0.313-0.325 (0.0123-0.0127)	30	1.30 (0.0511)	0.043-0.054 (0.0016-0.0021)	50 (master)	1.50 (0.0590)
0.300-0.311 (0.0118-0.0122)	31	1.31 (0.0515)	0.029-0.041 (0.0011-0.0016)	51	1.51 (0.0594)
0.286-0.298 (0.0112-0.0117)	32	1.32 (0.0519)	0.015-0.027 (0.0005-0.0010)	52	1.52 (0.0598)
0.272-0.284 (0.0107-0.0111)	33	1.33 (0.0523)	0.002-0.014 (0.00007-0.0005)	53	1.53 (0.0602)
0.259-0.271 (0.0101-0.0106)	34	1.34 (0.0527)	0.000-0.000 (0.0000-0.0000)	54	1.54 (0.0606)

N0101731

Fig. 10: Adjustment Shim Selection Chart

- Install the Crankshaft **TDC** Timing Peg and rotate the crankshaft slowly clockwise until the crankshaft balance weight is up against the Crankshaft **TDC** Timing Peg. The engine is now at **TDC** .

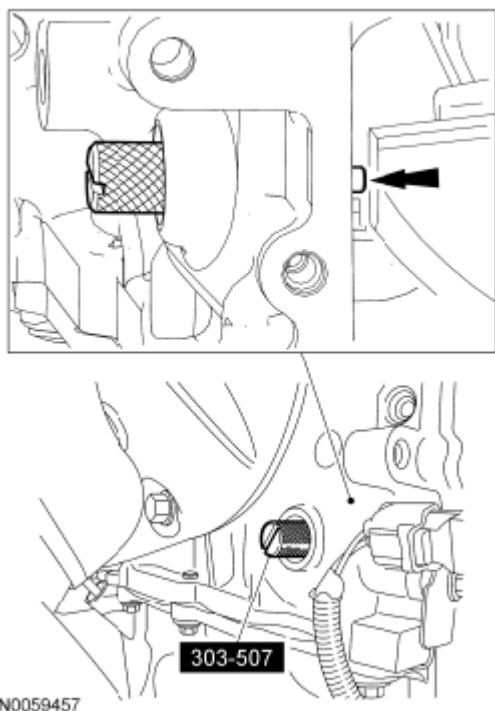

Fig. 11: Installing Crankshaft TDC Timing Peg

13. With the balancer unit shaft marks in the TDC position, slowly install the balancer unit to the cylinder block to avoid interference between the crankshaft drive gear and the balancer unit driven gear.

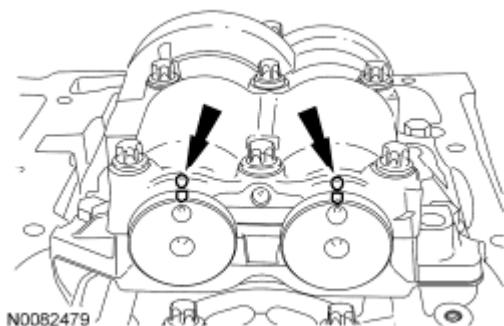

Fig. 12: Locating Balancer Unit And Shafts Reference Mark

14. Install the balancer unit bolts.
 - Tighten in the sequence shown in 2 stages.
 - Stage 1: Tighten to 25 Nm (18 lb-ft).
 - Stage 2: Tighten to 50 Nm (37 lb-ft).

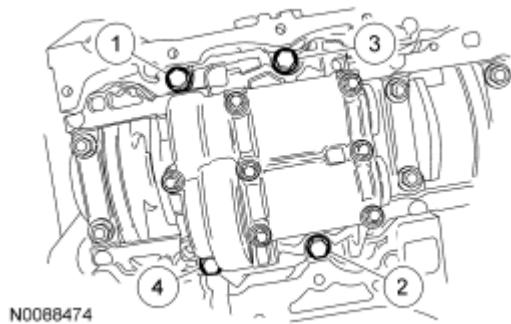

Fig. 13: Identifying Balancer Unit Bolts Tightening Sequence

15. **NOTE:** Remeasure the backlash and verify that it is within specified range at all of the following 6 positions: 10 degrees, 30 degrees, 100 degrees, 190 degrees, 210 degrees and 280 degrees. It will be necessary to reset the measuring equipment between measurements.

NOTE: The measurement must be taken with the Dial Indicator Gauge with Holding Fixture, a 5-mm Allen wrench and worm clamp set up as shown. Mark the Allen wrench with a file 80 mm (3.149 in) above the driven gear shaft center. Make sure the worm clamp and Allen wrench are not touching the balance shaft housing.

NOTE: For an accurate measurement while measuring the gear backlash, insert a screwdriver as shown into the crankshaft No. 1 crankweight area and set both the rotation and the thrust direction with the screwdriver, using a prying action as shown.

Position the Dial Indicator Gauge with Holding Fixture as shown. Measure the gear backlash.

- Position the Dial Indicator Gauge with Holding Fixture (1) on the Allen wrench 80 mm (3.149 in) above the driven gear shaft center (2) on the balancer unit.
- Rotate the crankshaft clockwise and measure the backlash at all of the following 6 positions: 10 degrees, 30 degrees, 100 degrees, 190 degrees, 210 degrees and 280 degrees.
- If the backlash exceeds the specified range of 0.005 to 0.101 mm (0.00019 to 0.0039 in), install a new balancer unit and repeat the procedure.

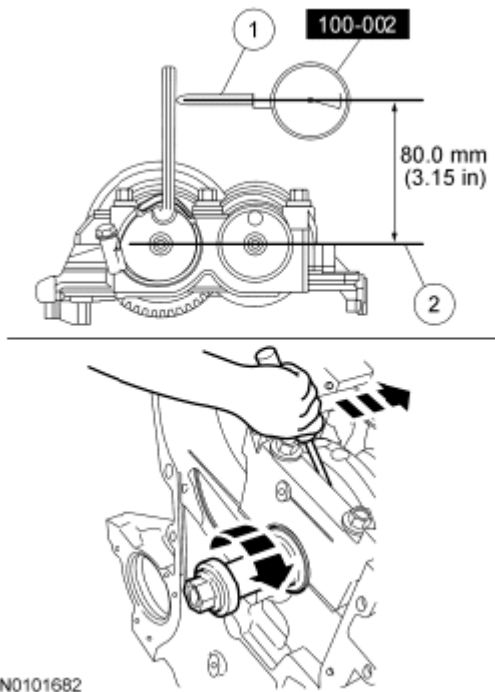

Fig. 14: Measuring Gear Backlash

IN-VEHICLE SERVICING

INTAKE MANIFOLD

Material

Item	Specification
Motorcraft SAE 5W-20 Premium Synthetic Blend Motor Oil XO-5W20-QSP (US); Motorcraft SAE 5W-20 Super Premium Motor Oil CXO-5W20-LSP12 (Canada); or equivalent	WSS-M2C930-A

2007 Ford Focus S

2007 ENGINE Engine - 2.0L and 2.3L - Focus

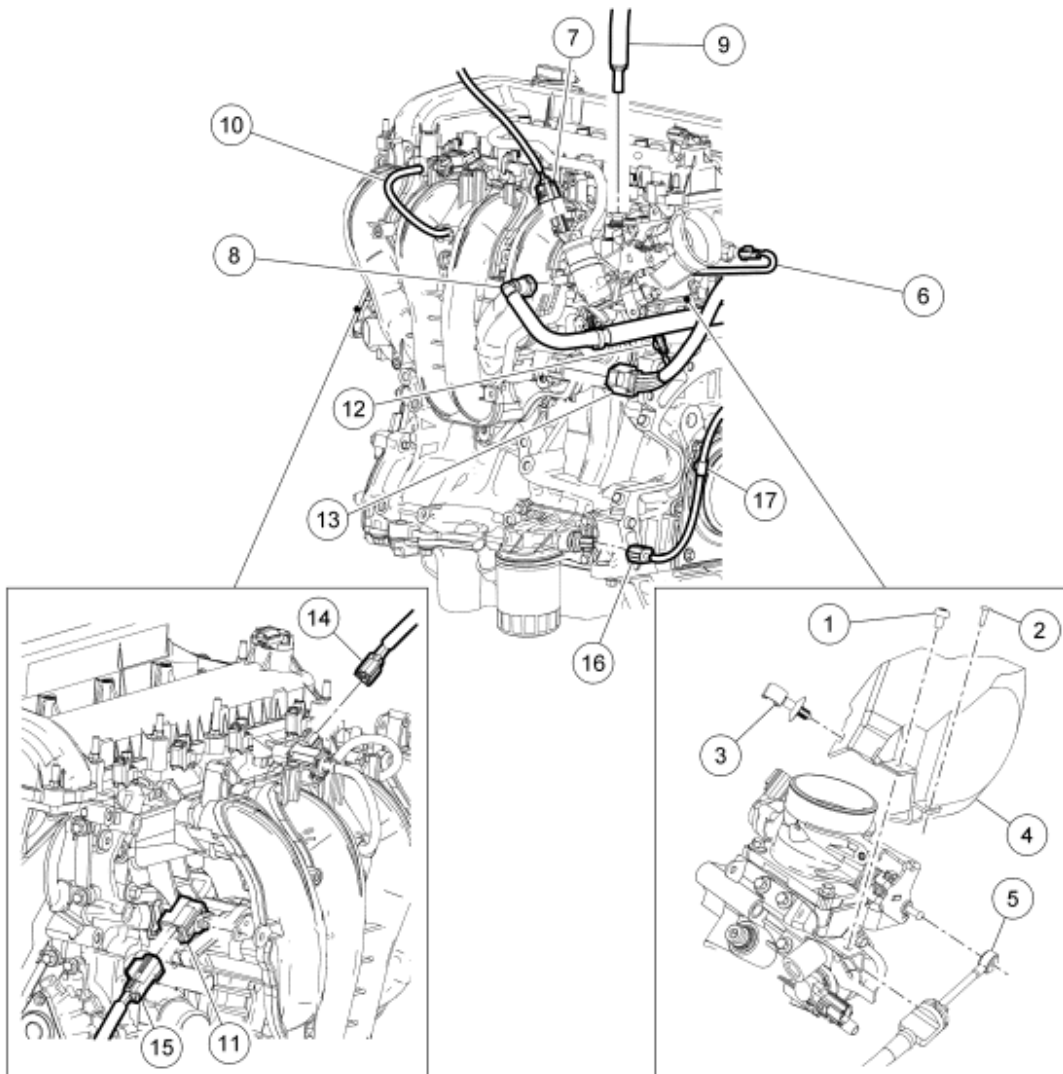

N0042245

Fig. 15: Identifying Intake Manifold Components (1 Of 2)
 Courtesy of FORD MOTOR CO.

Item	Part Number	Description
1	W504692	Snow shield mounting screw
2	W709419	Snow shield pushpin
3	-	Evaporative emissions hose pin-type retainer
4	9E766	Snow shield
5	9A758	Accelerator cable assembly
6	14A464	Throttle position (TP) sensor electrical connector
7	14A464	Idle air control (IAC) motor electrical connector (part of 12B637)

2007 Ford Focus S

2007 ENGINE Engine - 2.0L and 2.3L - Focus

8	9D289	Fuel vapor return hose
9	19D848	Power brake booster vacuum supply hose
10	9D430	Fuel rail pressure and temperature vacuum tube
11	14A464	Pin-type retainer (part of 12B637)
12	14A464	Intake manifold runner control (IMRC) electrical connector
13	14A464	Manifold absolute pressure (MAP) sensor electrical connector (part of 12B637)
14	14A464	Swirl control valve electrical connector (part of 12B637)
15	14A464	Knock sensor (KS) electrical connector (part of 12B637)
16	14A464	Oil pressure sender electrical connector (part of 12B637)
17	12B637	Engine control wiring harness retainer

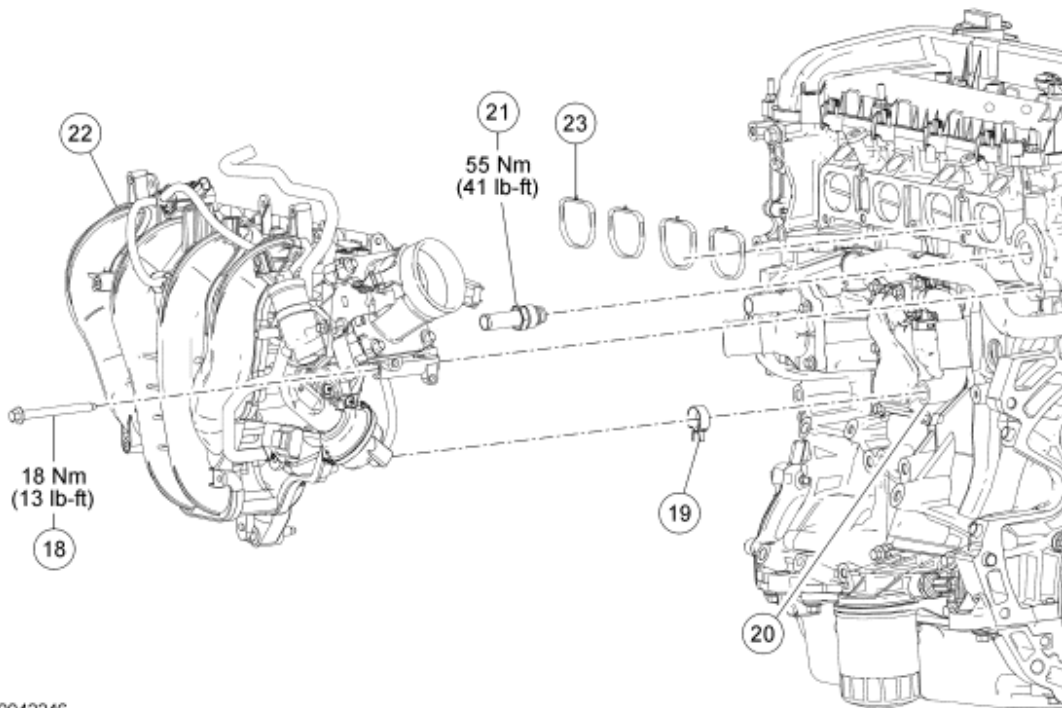

N0042246

Fig. 16: Identifying Intake Manifold Components (2 Of 2) (With Torque Specifications)
 Courtesy of FORD MOTOR CO.

Item	Part Number	Description
18	W500311	Intake manifold bolt (8 required)
19	-	Crankcase vent hose clamp (part of 6758)

20	6758	Positive crankcase ventilation (PCV) hose
21	9E470	Exhaust gas recirculation (EGR) tube
22	9424	Intake manifold
23	9461	Intake manifold gasket

REMOVAL

All engines

1. With vehicle in NEUTRAL, position it on a hoist. For additional information, refer to **JACKING AND LIFTING** article.
2. Remove the cooling fan motor and shroud assembly. For additional information, refer to **ENGINE COOLING** article.
3. Remove the lower intake manifold bolt.



Fig. 17: Locating Lower Intake Manifold Bolt
 Courtesy of FORD MOTOR CO.

4. Remove the air cleaner outlet pipe.
 - Loosen the clamps.
 - Disconnect the vent tube and remove the outlet pipe.

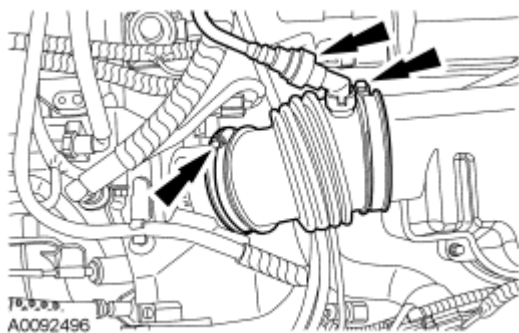

Fig. 18: Locating Vent Tube, Outlet Pipe And Clamp
 Courtesy of FORD MOTOR CO.

5. Remove the accelerator snow shield.
 - Detach the evaporative emissions hose pin-type retainer.
 - Remove the screw and pin-type retainer.
 - Remove the snow shield.

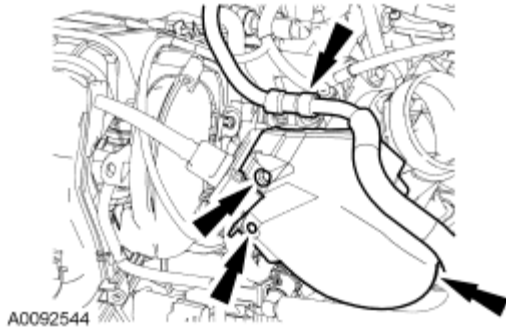

Fig. 19: Locating Accelerator Snow Shield, Screw And Pin-Type Retainers
 Courtesy of FORD MOTOR CO.

6. Disconnect the accelerator cable and speed control cable (if equipped).
 1. Disconnect the accelerator and speed control cable (if equipped) from the throttle body.
 2. Remove the 3 bolts and position the accelerator control cables and bracket aside.

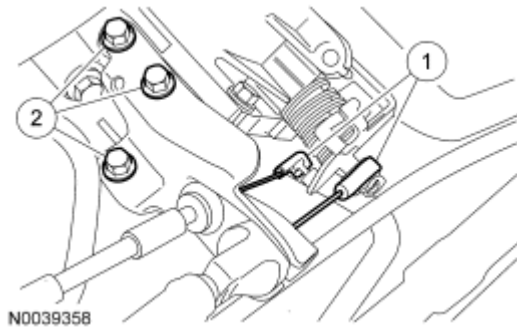

Fig. 20: Identifying Accelerator & Speed Control Cable And Bolts
 Courtesy of FORD MOTOR CO.

7. Disconnect the throttle position (TP) sensor electrical connector and wiring harness pin-type retainer.
8. Disconnect the idle air control (IAC) valve electrical connector and wiring harness pin-type retainer.
9. Disconnect the fuel vapor return hose.
10. Disconnect the power brake booster vacuum tube.
 - Depress the quick release locking ring.
 - Pull the vacuum tube out of the quick release fitting.

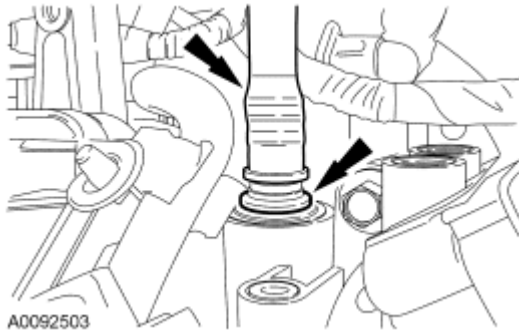

Fig. 21: Locating Power Brake Booster Vacuum Tube And Quick Release Locking Ring
Courtesy of FORD MOTOR CO.

11. Disconnect the fuel rail pressure and temperature sensor vacuum hose.

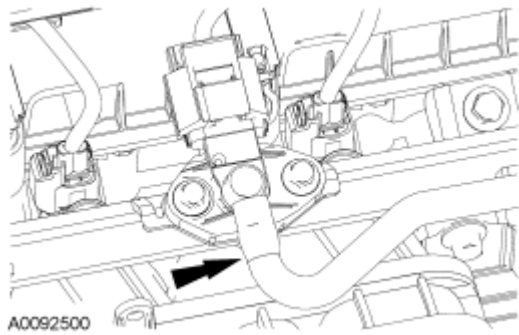

Fig. 22: Locating Fuel Rail Pressure And Temperature Sensor Vacuum Hose
Courtesy of FORD MOTOR CO.

12. Detach the wiring harness pin-type retainer.
13. Disconnect the intake manifold runner control (IMRC) actuator electrical connector.
14. Disconnect the manifold absolute pressure (MAP) sensor electrical connector.

2.0L engines

15. If equipped, disconnect the secondary air injection (AIR) vacuum supply hose.

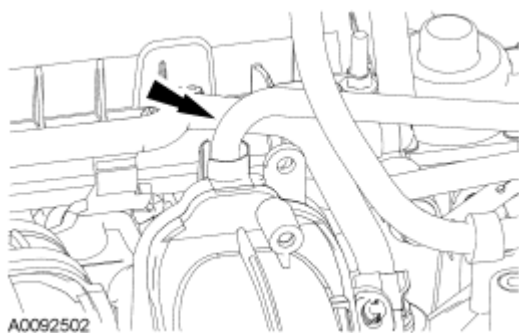

Fig. 23: Locating Secondary Air Injection Vacuum Supply Hose

Courtesy of FORD MOTOR CO.

16. Disconnect the swirl control valve electrical connector.

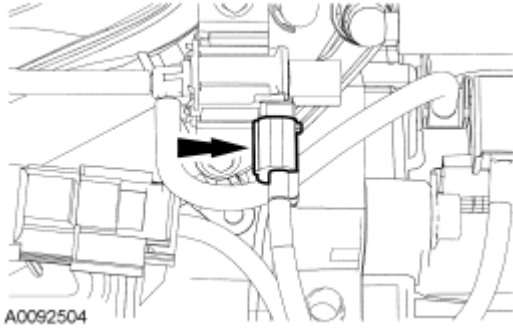

Fig. 24: Locating Swirl Control Valve Electrical Connector
Courtesy of FORD MOTOR CO.

17. Remove the bolt and the oil level indicator tube.

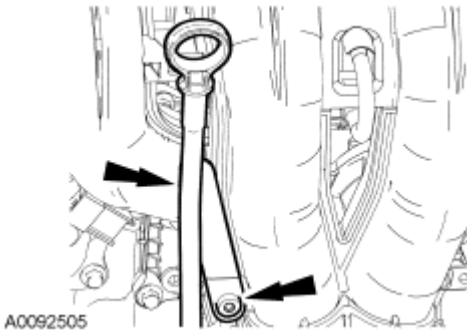

Fig. 25: Locating Bolt And Oil Level Indicator Tube
Courtesy of FORD MOTOR CO.

NOTE: There are 3 different size bolts used. Mark the location of the bolts to make sure installation is in the correct location.

18. Remove the 7 intake manifold bolts.

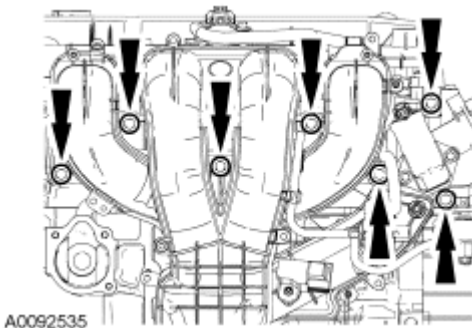

Fig. 26: Locating Intake Manifold Bolts
 Courtesy of FORD MOTOR CO.

2.3L engines

19. Disconnect the swirl valve electrical connectors and pin-type retainers.

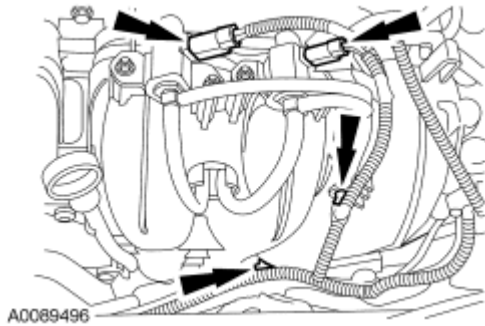

Fig. 27: Locating Swirl Valve Electrical Connectors And Pin-Type Retainers
 Courtesy of FORD MOTOR CO.

20. Remove the 2 bolts and the oil level indicator tube.

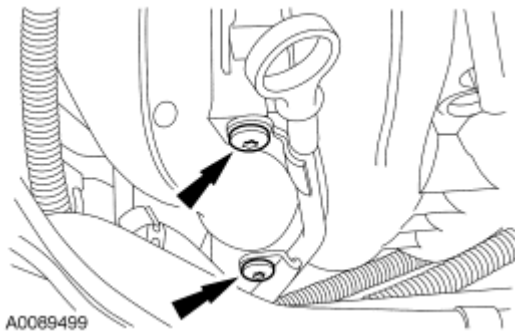

Fig. 28: Locating Oil Level Indicator Tube Bolts
 Courtesy of FORD MOTOR CO.

NOTE: There are 3 different size bolts used. Mark the location of the bolts to make sure installation is in the correct location.

21. Remove the 7 intake manifold bolts.

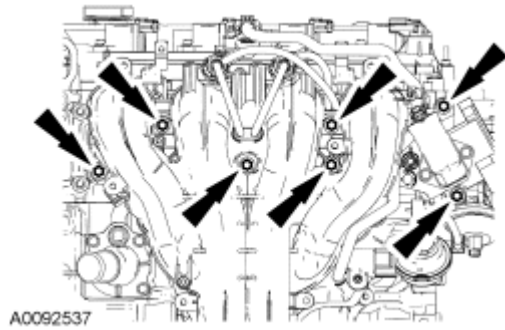

Fig. 29: Locating Intake Manifold Bolts
Courtesy of FORD MOTOR CO.

All engines

22. Raise the intake manifold enough to gain clearance to disconnect the knock sensor (KS) electrical connector.
23. Disconnect the positive crankcase ventilation (PCV) hose and remove the intake manifold.
24. Remove the exhaust gas recirculation (EGR) tube.

INSTALLATION

All engines

NOTE: 2.0L engine shown, 2.3L engine similar.

1. Inspect and install new intake manifold gaskets if necessary.

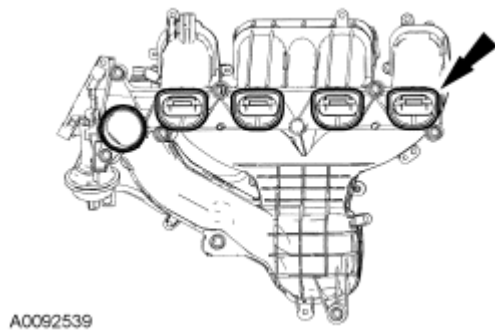

Fig. 30: Locating Intake Manifold Gaskets
Courtesy of FORD MOTOR CO.

2. Install the EGR tube and tighten to 55 Nm (41 lb-ft).

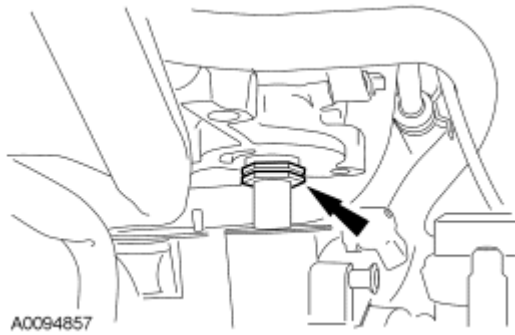

Fig. 31: Locating EGR Tube And Nut
Courtesy of FORD MOTOR CO.

3. Position the intake manifold and connect the PCV hose.
4. Connect the KS electrical connector.

2.3L engines

NOTE: Be sure to install the bolts in the previously marked locations.

NOTE: To ease installation of the intake manifold, lower center mounting bolt, use a 6-inch long, 5/16-inch diameter hose.

5. Install the intake manifold and the 7 mounting bolts.
 - Tighten to 18 Nm (13 lb-ft).

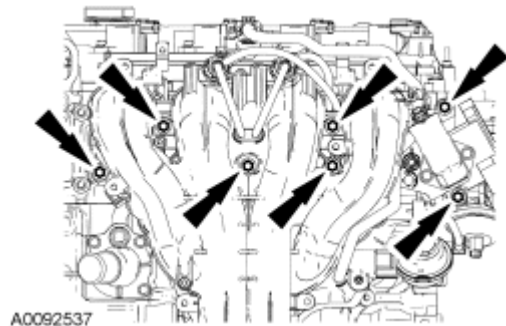

Fig. 32: Locating Intake Manifold Bolts
Courtesy of FORD MOTOR CO.

NOTE: Lubricate the O-ring with clean engine oil.

6. Install the oil level indicator tube and 2 bolts.
 - Tighten to 10 Nm (89 lb-in).

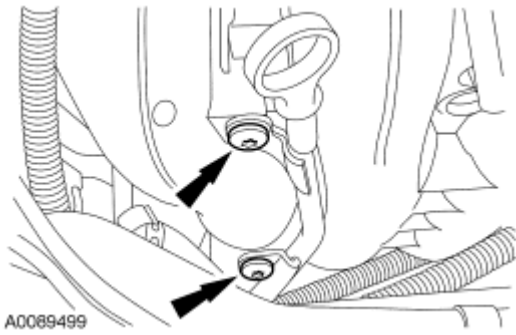

Fig. 33: Locating Oil Level Indicator Tube Bolts
 Courtesy of FORD MOTOR CO.

7. Connect the swirl valve electrical connectors and pin-type retainers.

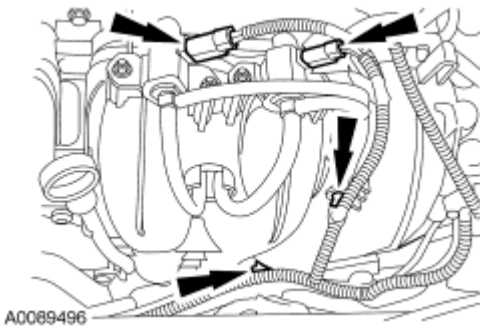

Fig. 34: Locating Swirl Valve Electrical Connectors And Pin-Type Retainers
 Courtesy of FORD MOTOR CO.

2.0L engines

NOTE: Be sure to install the bolts in the previously marked locations.

8. Install the intake manifold and the 7 mounting bolts.
 - Tighten to 18 Nm (13 lb-ft).

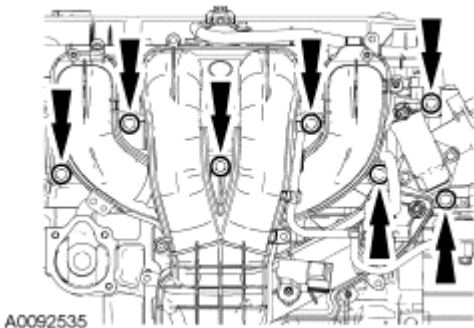

Fig. 35: Locating Intake Manifold Bolts
 Courtesy of FORD MOTOR CO.

NOTE: Lubricate the O-ring with clean engine oil.

9. Install the oil level indicator tube and bolt.
 - Tighten to 10 Nm (89 lb-in).

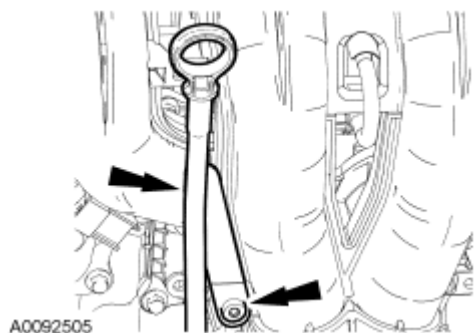

Fig. 36: Locating Bolt And Oil Level Indicator Tube
Courtesy of FORD MOTOR CO.

10. Connect the swirl control valve electrical connector.

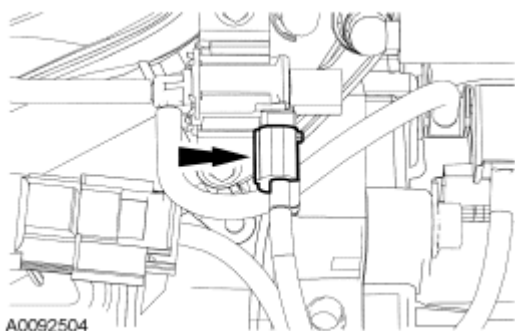

Fig. 37: Locating Swirl Control Valve Electrical Connector
Courtesy of FORD MOTOR CO.

11. If equipped, connect the AIR vacuum supply hose.

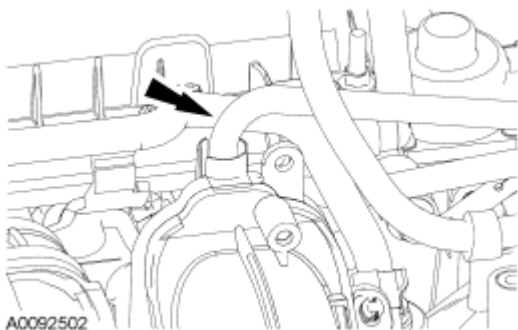

Fig. 38: Locating Secondary Air Injection Vacuum Supply Hose
Courtesy of FORD MOTOR CO.

All engines

12. Install the lower intake manifold bolt.
 - Tighten to 18 Nm (13 lb-ft).



Fig. 39: Locating Lower Intake Manifold Bolt
Courtesy of FORD MOTOR CO.

13. Connect the MAP sensor electrical connector.
14. Connect the IMRC actuator electrical connector.
15. Attach the wiring harness pin-type retainer.

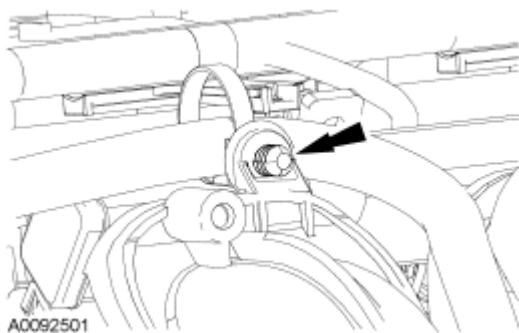

Fig. 40: Locating Wiring Harness Pin-Type Retainer
Courtesy of FORD MOTOR CO.

16. Connect the fuel rail pressure and temperature sensor vacuum hose.
17. Connect the power brake booster vacuum tube.
 - Push the vacuum tube into the quick release fitting.

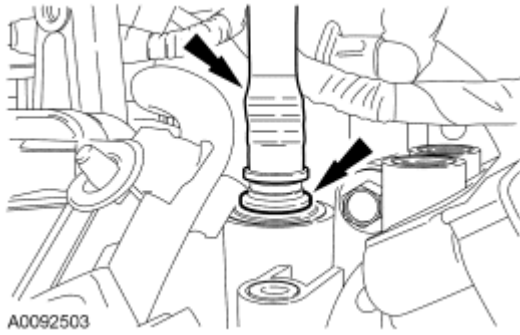

Fig. 41: Locating Power Brake Booster Vacuum Tube And Quick Release Locking Ring
Courtesy of FORD MOTOR CO.

18. Connect the fuel vapor return hose.
19. Connect the IAC valve electrical connector and wiring harness pin-type retainer.
20. Connect the TP sensor electrical connector and wiring harness pin-type retainer.
21. Connect the accelerator cable and speed control cable (if equipped).
 1. Install the accelerator cable bracket and 3 bolts.
 - Tighten to 10 Nm (89 lb-in).
 2. Connect the accelerator and speed control cable (if equipped) to the throttle body.

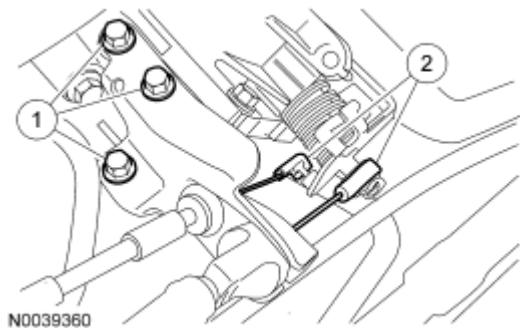

Fig. 42: Identifying Accelerator & Speed Control Cable And Bolts
Courtesy of FORD MOTOR CO.

22. Install the accelerator control snow shield.
 - Position the snow shield and tighten the retainer to 10 Nm (89 lb-in).
 - Attach the evaporative emissions hose pin-type retainer.

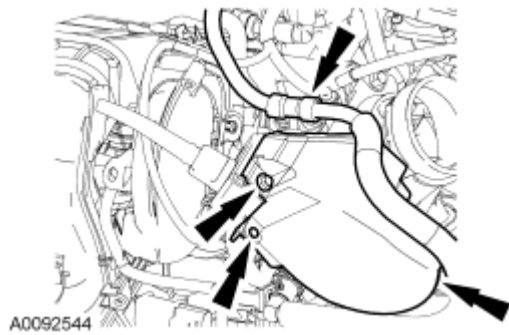

Fig. 43: Locating Accelerator Snow Shield, Screw And Pin-Type Retainers
Courtesy of FORD MOTOR CO.

23. Install the air cleaner outlet pipe.
 - Tighten the clamps to 4 Nm (35 lb-in).

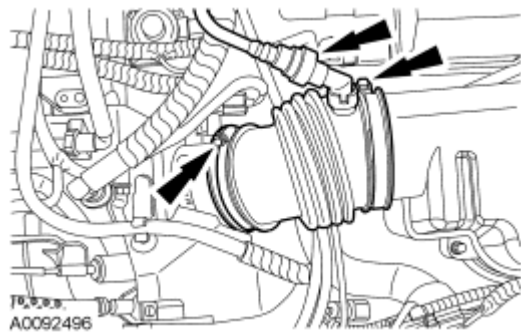

Fig. 44: Locating Vent Tube, Outlet Pipe And Clamp
Courtesy of FORD MOTOR CO.

24. Install the cooling fan motor and shroud assembly. For additional information, refer to **ENGINE COOLING** article.

VALVE COVER

2007 Ford Focus S

2007 ENGINE Engine - 2.0L and 2.3L - Focus

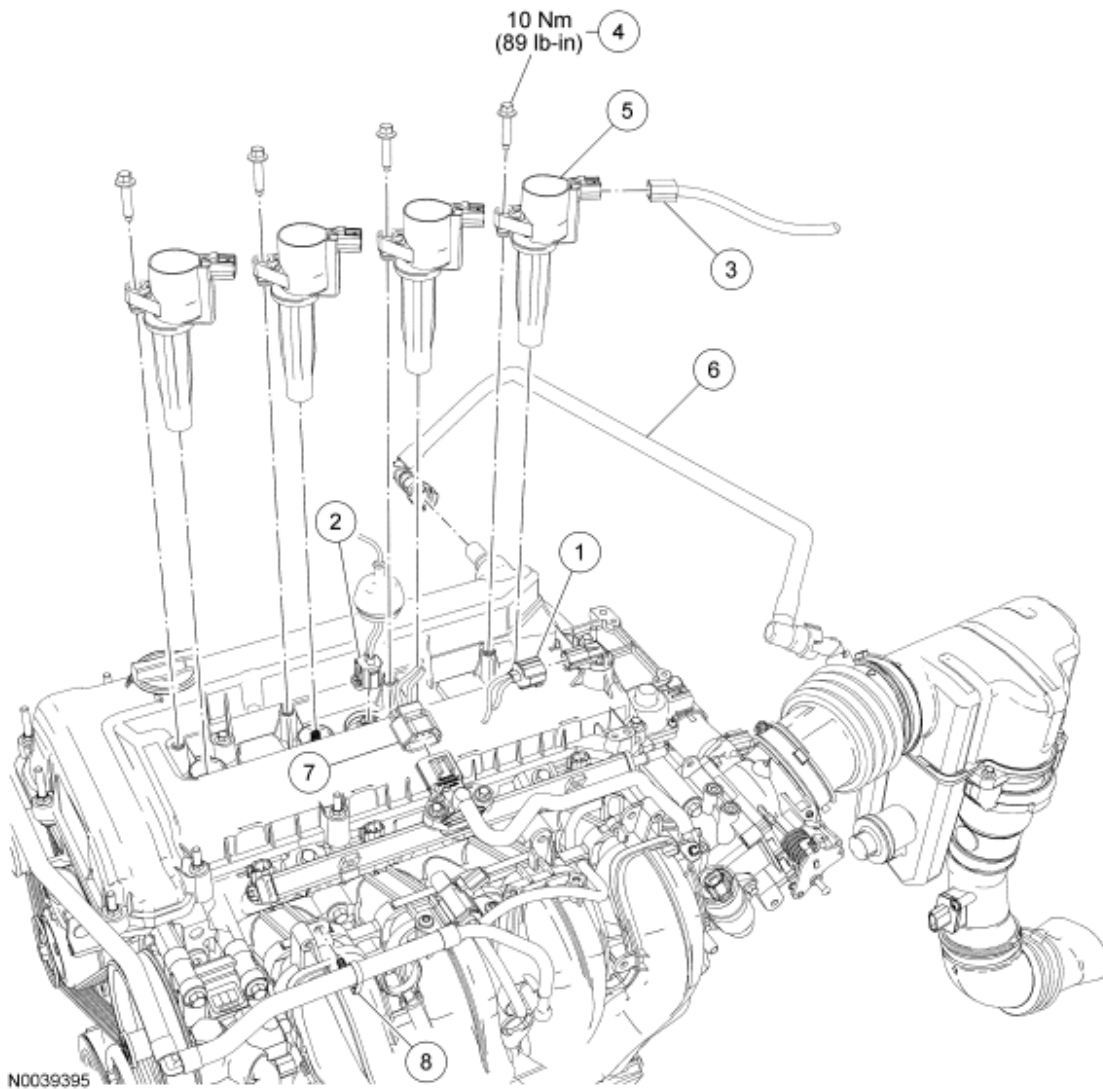

Fig. 45: Identifying Valve Cover Components (1 Of 2) (With Torque Specifications)
 Courtesy of FORD MOTOR CO.

Item	Part Number	Description
1	14A464	Camshaft position (CMP) sensor electrical connector (part of 12B637)
2	14A464	Cylinder head temperature (CHT) sensor electrical connector (part of 12B637)
3	14A464	Ignition coil-on-plug electrical connector (4 required)
4	W500215	Ignition coil-to-valve cover bolt (4 required)
5	12A192	Ignition coil (4 required)
6	6853	Crankcase breather tube
		Fuel rail pressure and temperature sensor

2007 Ford Focus S

2007 ENGINE Engine - 2.0L and 2.3L - Focus

7	14A464	electrical connector (part of 12B637)
8	-	Vacuum tube retainer (part of 9E498)

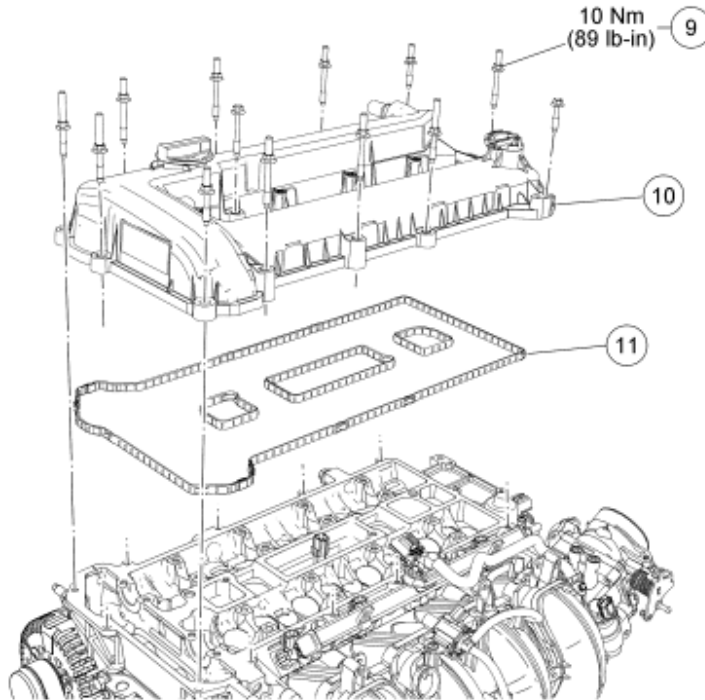

N0039396

Fig. 46: Identifying Valve Cover Components (2 Of 2) (With Torque Specifications)
 Courtesy of FORD MOTOR CO.

Item	Part Number	Description
9	W500215	Valve cover retainer (14 required)
10	6582	Valve cover
11	6584	Valve cover gasket

REMOVAL

All vehicles

CAUTION: During engine repair procedures, cleanliness is extremely important. Any foreign material, including any material created while cleaning gasket surfaces, that enters the oil passages, coolant passages or the oil pan can cause engine failure.

1. Disconnect the battery ground cable. For additional information, refer to **BATTERY, MOUNTING AND CABLES** article.
2. Disconnect the camshaft position (CMP) sensor electrical connector.
3. Lift up the connector boot and disconnect the cylinder head temperature (CHT) sensor electrical connector.

4. Disconnect the ignition coil-on-plug electrical connectors.
5. Remove the 4 ignition coil-to-valve cover bolts and the ignition coils.
6. Disconnect the breather tube from the valve cover.
7. Disconnect the fuel rail pressure and temperature sensor and the fuel injector electrical connectors. Detach the wiring harness retainers.

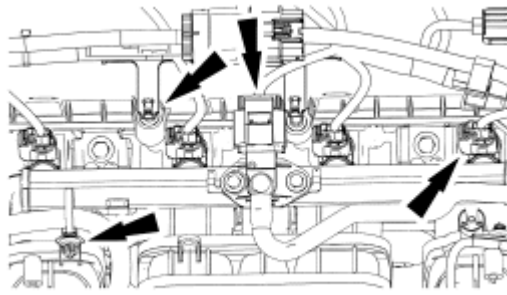

A0091737

Fig. 47: Locating Fuel Rail Pressure & Temperature Sensor And Fuel Injector Electrical Connectors

Courtesy of FORD MOTOR CO.

8. Remove the radio interference capacitor bracket bolt and position the bracket aside.

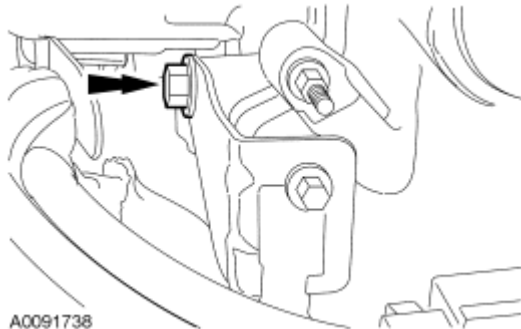

A0091738

Fig. 48: Locating Radio Interference Capacitor Bracket Bolt

Courtesy of FORD MOTOR CO.

Vehicles with secondary air injection (AIR)

9. Disconnect the heated oxygen sensor (HO2S) electrical connector.

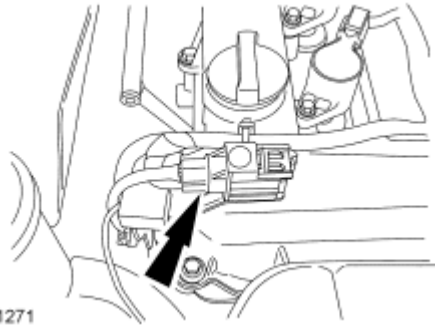

A0071271

Fig. 49: Locating HO2S Electrical Connector
 Courtesy of FORD MOTOR CO.

All vehicles

10. Detach all of the wiring harness retainers from the valve cover studs and position the harness aside.

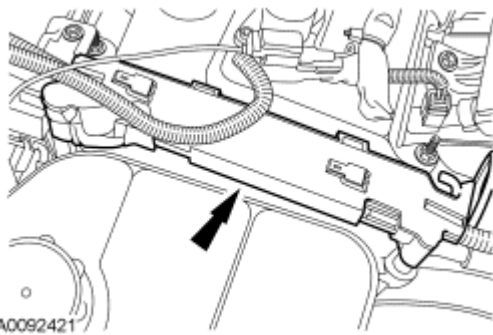

A0092421

Fig. 50: Locating Wiring Harness Retainers
 Courtesy of FORD MOTOR CO.

11. Remove the 14 valve cover retainers, the valve cover and gasket.
 - Discard the valve cover gasket.

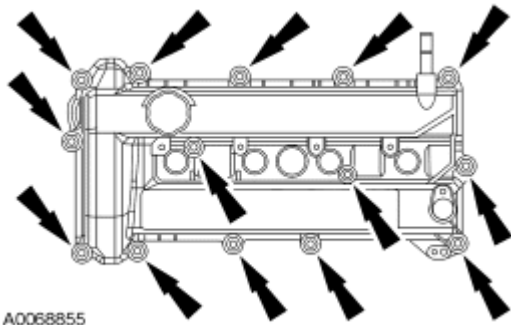

A0068855

Fig. 51: Locating Valve Cover Bolts
 Courtesy of FORD MOTOR CO.

INSTALLATION

All vehicles

CAUTION: Do not use metal scrapers, wire brushes, power abrasive discs or other abrasive means to clean the sealing surfaces. These tools cause scratches and gouges which make leak paths.

1. Clean and inspect the sealing surfaces.
2. Install the valve cover, a new gasket and the 14 retainers.
 - Tighten in the sequence shown to 10 Nm (89 lb-in).

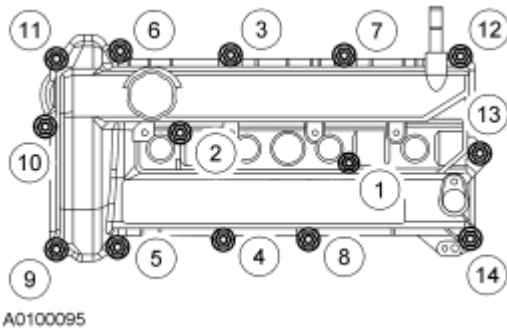

Fig. 52: Identifying Valve Cover Bolts Tightening Sequence
Courtesy of FORD MOTOR CO.

3. Position the wiring harness and attach all of the wiring harness retainers to the valve cover studs.

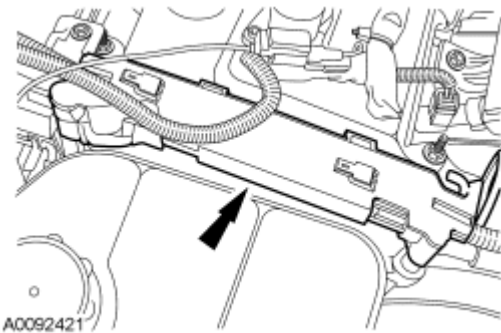
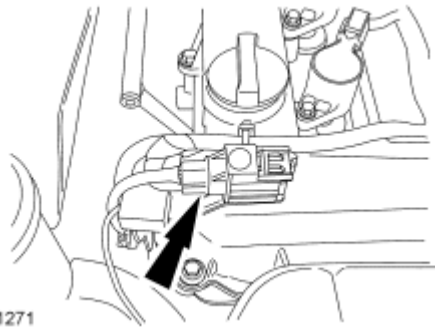

Fig. 53: Locating Wiring Harness Retainers
Courtesy of FORD MOTOR CO.

Vehicles with secondary air injection (AIR)

4. Connect the HO2S electrical connector.



A0071271

Fig. 54: Locating HO2S Electrical Connector
Courtesy of FORD MOTOR CO.

All vehicles

5. Position the radio interference capacitor bracket and install the bolt.
 - Tighten to 10 Nm (89 lb-in).

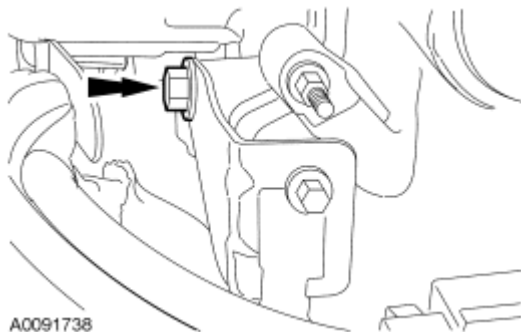

A0091738

Fig. 55: Locating Radio Interference Capacitor Bracket Bolt
Courtesy of FORD MOTOR CO.

6. Attach the wiring harness retainers. Connect the fuel rail pressure and temperature sensor and the fuel injectors electrical connectors.

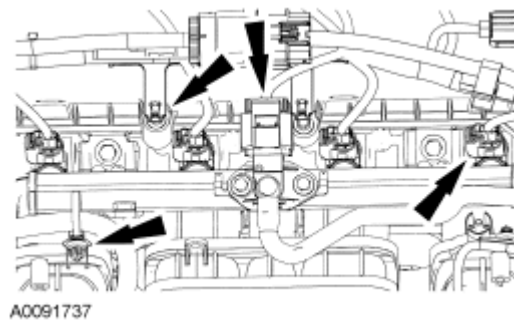

A0091737

Fig. 56: Locating Fuel Rail Pressure & Temperature Sensor And Fuel Injector Electrical Connectors
Courtesy of FORD MOTOR CO.

7. Install the breather tube on the valve cover.
8. Install the ignition coils and the 4 ignition coil-to-valve cover bolts.
 - Tighten to 10 Nm (89 lb-in).
9. Connect the ignition coil-on-plug electrical connectors.
10. Connect the CHT sensor electrical connector and install the connector boot.
 - Tighten to 10 Nm (89 lb-in).
11. Connect the CMP sensor electrical connector.
12. Connect the battery ground cable. For additional information, refer to **BATTERY, MOUNTING AND CABLES** article.

LOWER END COMPONENTS - EXPLODED VIEW

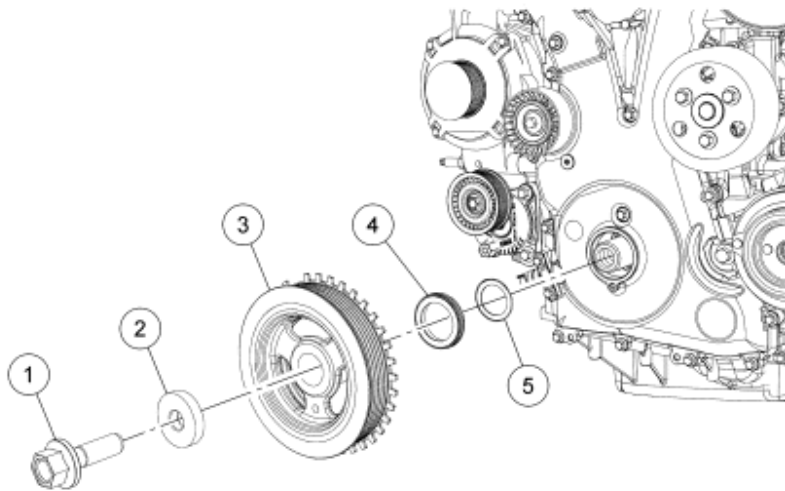

N0078557

Fig. 57: Crankshaft Pulley and Crankshaft Front Seal
 Courtesy of FORD MOTOR CO.

Item	Part Number	Description
1	6K340	Crankshaft pulley bolt
2	-	Crankshaft pulley washer (part of 6K340)
3	6316	Crankshaft pulley
4	6700	Crankshaft front seal
5	6378	Diamond washer

2007 Ford Focus S

2007 ENGINE Engine - 2.0L and 2.3L - Focus

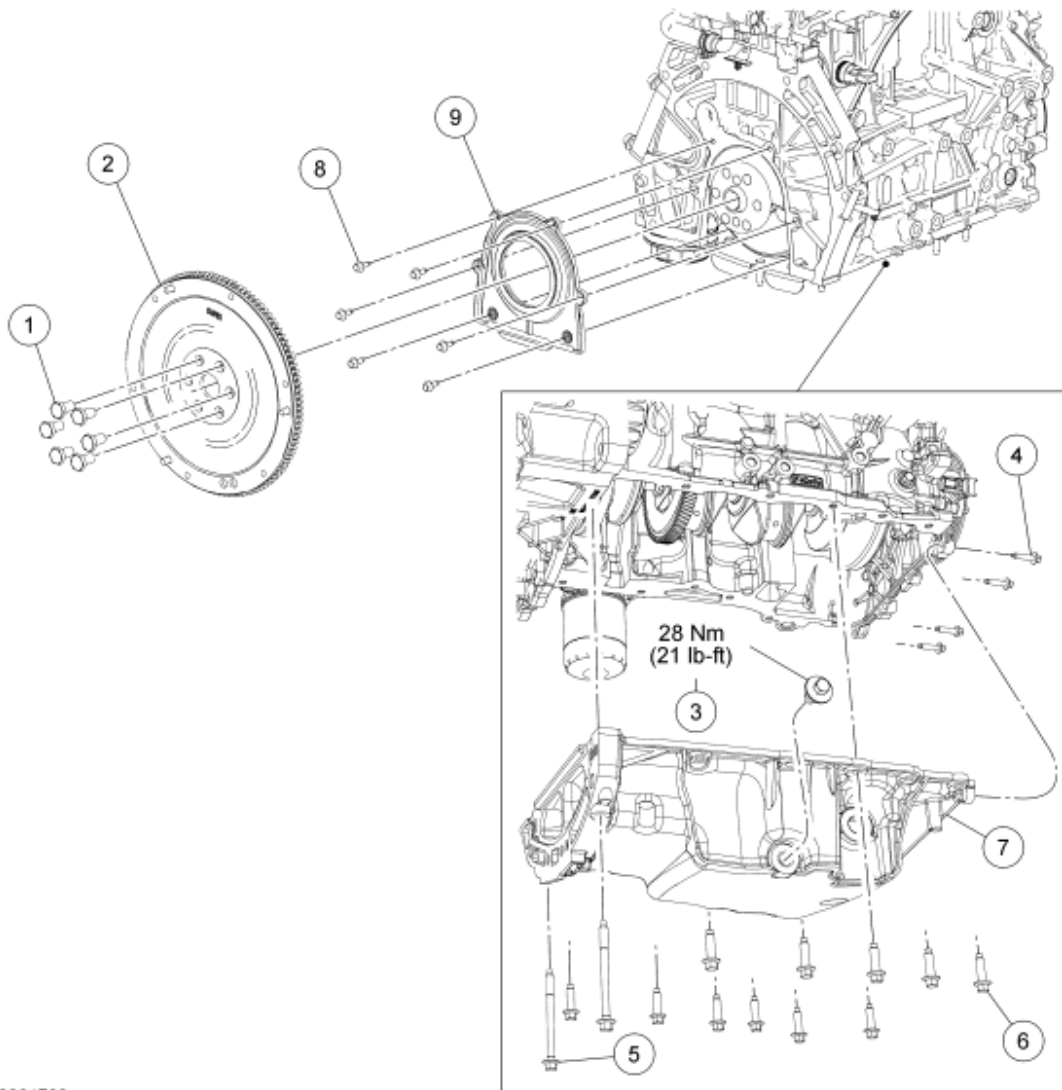

N0061790

Fig. 58: Flexplate, Flywheel and Crankshaft Rear Seal With Retainer Plate
 Courtesy of FORD MOTOR CO.

Item	Part Number	Description
1	6379	Flexplate or flywheel bolt (6 required)
2	6477	Flexplate or flywheel
3	6730	Oil pan drain plug
4	W500215	Engine front cover bolt (4 required)
5	W706284	Oil pan bolt (2 required)
6	W500224	Oil pan bolt (11 required)
7	6675	Oil pan
8	W500212	Crankshaft rear oil seal with retainer plate bolt (6 required)
9	6K318	Crankshaft rear oil seal with retainer

2007 Ford Focus S



2007 ENGINE Engine - 2.0L and 2.3L - Focus

plate

1. For additional information, refer to the appropriate procedures.

CRANKSHAFT PULLEY

Special Tools

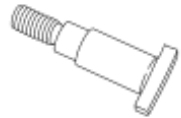
Illustration	Tool Name	Tool Number
 ST2545-A	Alignment Plate, Camshaft	303-465 (T94P-6256-CH)
 ST2538-A	Timing Peg, Crankshaft	303-507
 ST2547-A	Holding Fixture, Drive Pinion Flange	205-126 (T78P-4851-A)
 ST2539-A	Adapter for 205-126	(205-072-02)

Material

Item	Specification
Motorcraft SAE 5W-20 Premium Synthetic Blend Motor Oil XO-5W20-QSP (US); Motorcraft SAE 5W-20 Super Premium Motor Oil CXO-5W20-LSP12 (Canada); or equivalent	WSS-M2C930-A

REMOVAL

CAUTION: Do not loosen or remove the crankshaft pulley bolt without first installing the special tools as instructed in this procedure. The crankshaft pulley and the crankshaft timing sprocket are not keyed to the crankshaft. The crankshaft, the crankshaft sprocket and the pulley are fitted together by

friction, using diamond washers between the flange faces on each part. For that reason, the crankshaft sprocket is also unfastened if you loosen the pulley bolt. Before any repair requiring loosening or removal of the crankshaft pulley bolt, the crankshaft and camshafts must be locked in place by the special service tools, otherwise severe engine damage can occur.

CAUTION: During engine repair procedures, cleanliness is extremely important. Any foreign material, including any material created while cleaning gasket surfaces, that enters the oil passages, coolant passages or the oil pan can cause engine failure.

1. With the vehicle in NEUTRAL, position it on a hoist. For additional information, refer to **JACKING AND LIFTING** article.
2. Remove the accessory drive belt. For additional information, refer to **ACCESSORY DRIVE** article.
3. Remove the valve cover. For additional information, refer to **Valve Cover**.

CAUTION: Failure to position the No. 1 piston at top dead center (TDC) can result in damage to the engine. Turn the engine in the normal direction of rotation only.

4. Using the crankshaft pulley bolt, turn the crankshaft clockwise to position the No. 1 piston at TDC.
 - The hole in the crankshaft pulley should be in the 6 o'clock position.

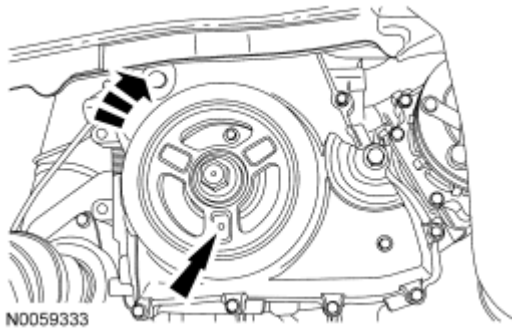

Fig. 59: Turning Crankshaft Clockwise
Courtesy of FORD MOTOR CO.

CAUTION: The special tool 303-465 is for camshaft alignment only. Using this tool to prevent engine rotation can result in engine damage.

NOTE: The camshaft timing slots are offset. If the special tool cannot be installed, rotate the crankshaft one complete revolution clockwise to correctly position the camshafts.

5. Install the special tool in the slots on the rear of both camshafts.

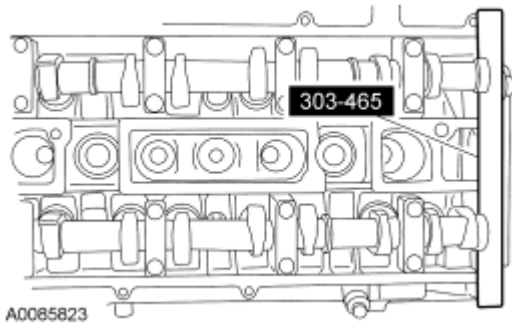

Fig. 60: Identifying Special Camshaft Tool (303-465)
Courtesy of FORD MOTOR CO.

6. Remove the engine plug bolt.

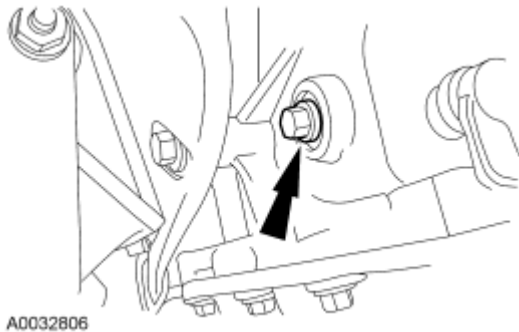

Fig. 61: Locating Engine Plug Bolt
Courtesy of FORD MOTOR CO.

NOTE: The special tool will contact the crankshaft and prevent it from turning past TDC. However, the crankshaft can still be rotated in the counterclockwise direction. The crankshaft must remain at the TDC position during the crankshaft pulley removal and installation.

7. Install the special tool.

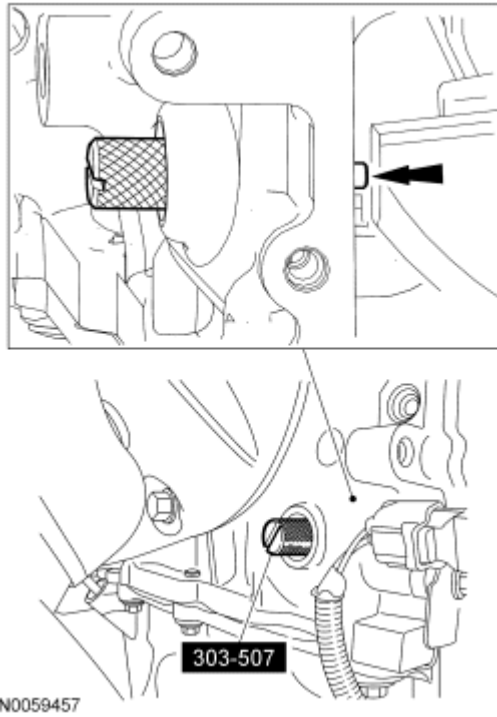

Fig. 62: Identifying Special Tool (303-507)
Courtesy of FORD MOTOR CO.

8. Assemble the special tools using 4 hardened washers in the locations shown.

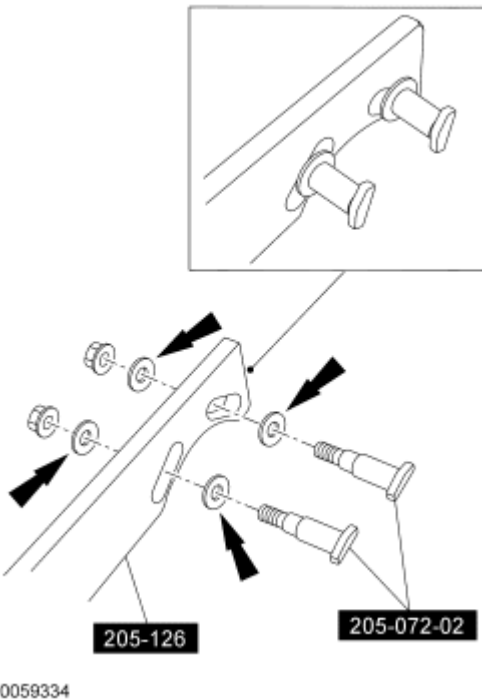

Fig. 63: Assembling Special Tools (205-126 And 205-072-02) And Hardened Washers

Courtesy of FORD MOTOR CO.

CAUTION: The crankshaft must remain in the TDC position during removal of the pulley bolt or damage to the engine can occur. Therefore, the crankshaft pulley must be held in place with the special tool and the bolt should be removed using an air impact wrench (1/2-in drive minimum).

CAUTION: The crankshaft sprocket diamond washer may come off with the crankshaft pulley. The diamond washer must be replaced; remove and discard the diamond washer. If the diamond washer is not installed, engine damage may occur.

9. Using the special tools and an air impact wrench, remove the crankshaft pulley.
 - Remove and discard the crankshaft pulley bolt and washer.
 - Remove the crankshaft pulley.
 - Remove the diamond washer and discard.

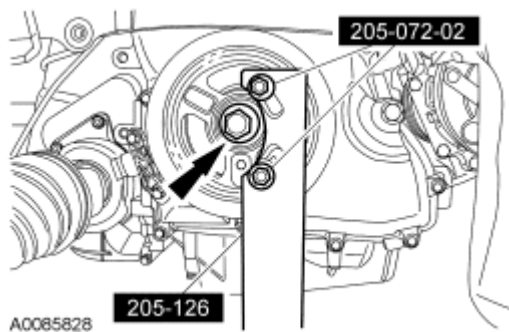

Fig. 64: Using Special Tools (205-126 And 205-072-02)
Courtesy of FORD MOTOR CO.

INSTALLATION

1. Install a new diamond washer.

CAUTION: Do not install the crankshaft pulley bolt at this time.

NOTE: Apply clean engine oil on the seal area before installing.

2. Position the crankshaft pulley onto the crankshaft with the hole in the pulley at the 6 o'clock position.

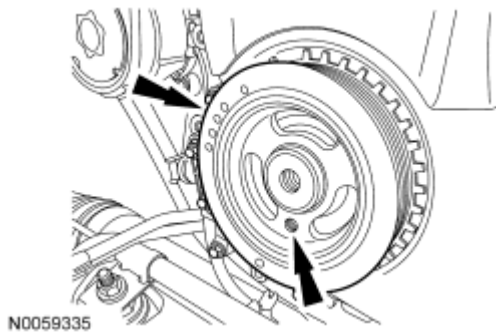

Fig. 65: Locating Crankshaft Pulley & Hole
Courtesy of FORD MOTOR CO.

CAUTION: Only hand-tighten the 6 mm (0.23 in) bolt or damage to the front cover can occur.

NOTE: This step will correctly align the crankshaft pulley to the crankshaft.

3. Install a standard 6 mm (0.23 in) x 18 mm (0.7 in) bolt through the crankshaft pulley and thread it into the front cover.

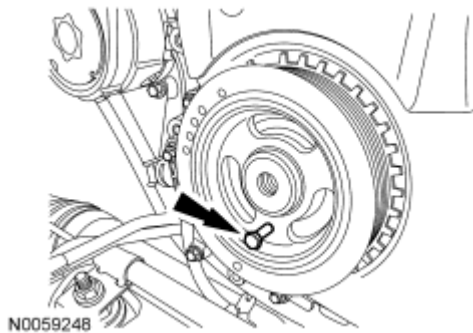
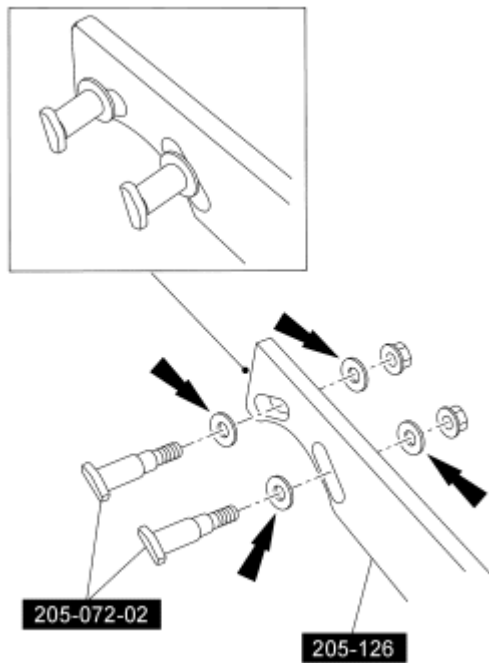

Fig. 66: Locating Crankshaft Pulley Bolt
Courtesy of FORD MOTOR CO.

4. Assemble the special tools using 4 hardened washers in the locations shown.



N0059336

Fig. 67: Assembling Special Tools (205-126 And 205-072-02)
Courtesy of FORD MOTOR CO.

CAUTION: The crankshaft must remain in the TDC position during installation of the pulley bolt or damage to the engine can occur. Therefore, the crankshaft pulley must be held in place with the special tool and the bolt should be installed using hand tools only.

CAUTION: Do not reuse the crankshaft pulley bolt.

5. Install a new crankshaft pulley bolt. Using the special tools to hold the crankshaft pulley in place, tighten the crankshaft pulley bolt in 2 stages:
 - Stage 1: Tighten to 100 Nm (74 lb-ft).
 - Stage 2: Tighten an additional 90 degrees (1/4 turn).

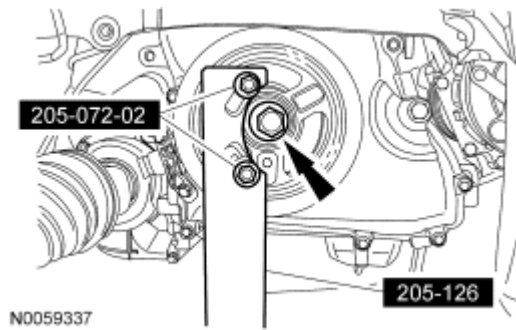

Fig. 68: Using Special Tools (205-126 And 205-072-02)
Courtesy of FORD MOTOR CO.

6. Remove the 6 mm (0.23 in) x 18 mm (0.7 in) bolt.

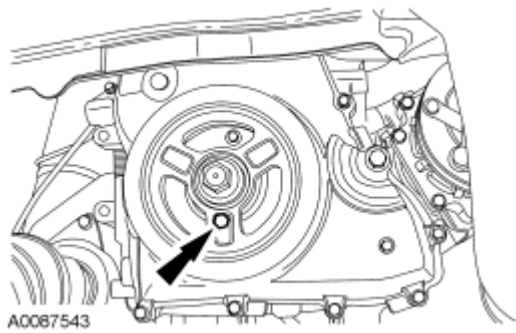

Fig. 69: Aligning Crankshaft Pulley Bolt Holes
Courtesy of FORD MOTOR CO.

7. Remove the special tool.



Fig. 70: Identifying Special Tool (303-507)
Courtesy of FORD MOTOR CO.

8. Remove the special tool.

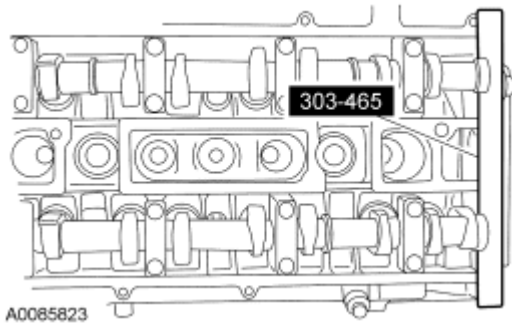

Fig. 71: Identifying Special Camshaft Tool (303-465)
Courtesy of FORD MOTOR CO.

NOTE: Only turn the engine in the normal direction of rotation.

9. Turn the crankshaft clockwise 1 and 3/4 turns.
10. Install the special tool.

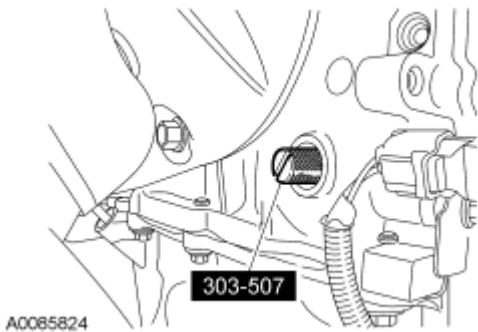

Fig. 72: Identifying Special Tool (303-507)
Courtesy of FORD MOTOR CO.

NOTE: Only turn the engine in the normal direction of rotation.

11. Turn the crankshaft clockwise until the crankshaft contacts the special tool.

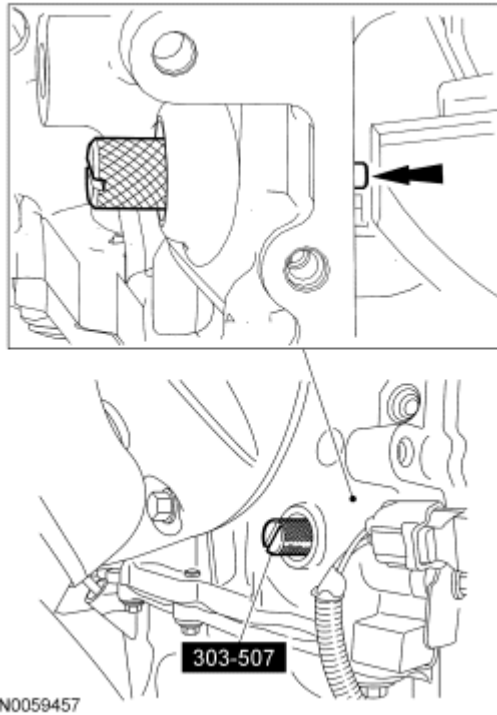

Fig. 73: Identifying Special Tool (303-507)
 Courtesy of FORD MOTOR CO.

CAUTION: Only hand-tighten the bolt or damage to the front cover can occur.

12. Using the 6 mm (0.23 in) x 18 mm (0.7 in) bolt, check the position of the crankshaft pulley.
 - If it is not possible to install the bolt, the engine valve timing must be corrected by repeating this procedure.

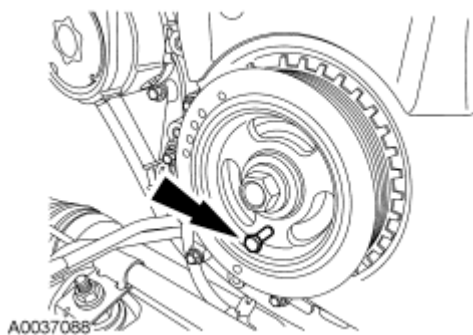

Fig. 74: Installing Bolt Through Crankshaft Pulley And Thread It Into Front Cover
 Courtesy of FORD MOTOR CO.

13. Install the special tool to check the position of the camshafts.
 - If it is not possible to install the special tool, the engine valve timing must be corrected by repeating this procedure.

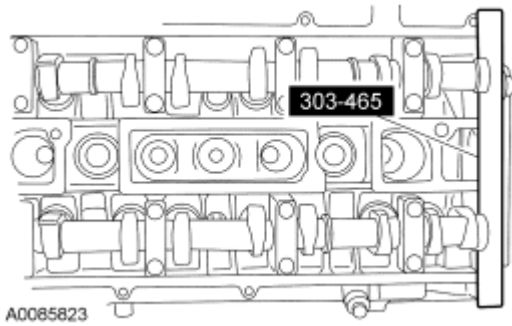

Fig. 75: Identifying Special Camshaft Tool (303-465)
Courtesy of FORD MOTOR CO.

14. Remove the special tool.

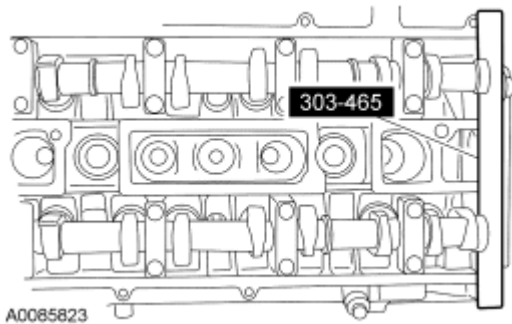

Fig. 76: Identifying Special Camshaft Tool (303-465)
Courtesy of FORD MOTOR CO.

15. Remove the 6 mm (0.23 in) x 18 mm (0.7 in) bolt.

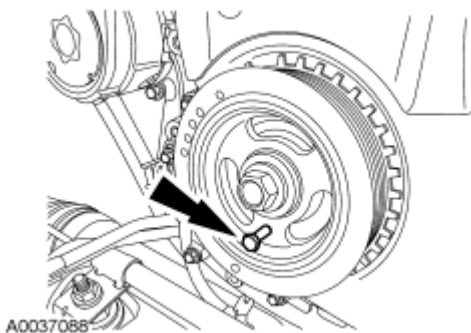

Fig. 77: Installing Bolt Through Crankshaft Pulley And Thread It Into Front Cover
Courtesy of FORD MOTOR CO.

16. Remove the special tool.

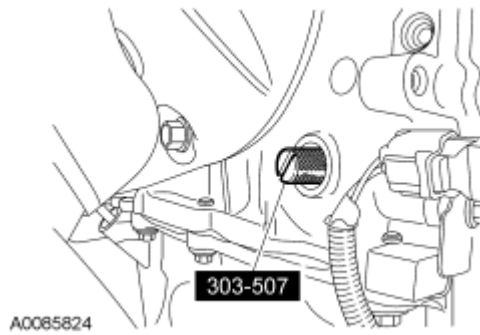

Fig. 78: Identifying Special Tool (303-507)
 Courtesy of FORD MOTOR CO.

17. Install the engine plug bolt.
 - Tighten to 20 Nm (15 lb-ft).
18. Install the accessory drive belt. For additional information, refer to **ACCESSORY DRIVE** article.
19. Install the valve cover. For additional information, refer to **Valve Cover**.

CRANKSHAFT FRONT SEAL

Special Tools

Illustration	Tool Name	Tool Number
<p>ST1917-A</p>	Installer, Front Oil Seal	303-096 (T74P-6150-A)
<p>ST1385-A</p>	Remover, Seal	303-409 (T92C-6700-CH)

Material

Item	Specification
Motorcraft SAE 5W-20 Premium Synthetic Blend Motor Oil XO-5W20-QSP (US); Motorcraft SAE 5W-20 Super Premium Motor Oil CXO-5W20-LSP12 (Canada); or equivalent	WSS-M2C930-A

REMOVAL

CAUTION: Do not loosen or remove the crankshaft pulley bolt without first installing

the special tools as instructed in this procedure. The crankshaft pulley and the crankshaft timing sprocket are not keyed to the crankshaft. The crankshaft, the crankshaft sprocket and the pulley are fitted together by friction, using diamond washers between the flange faces on each part. For that reason, the crankshaft sprocket is also unfastened if the pulley bolt is loosened. Before any repair requiring loosening or removal of the crankshaft pulley bolt, the crankshaft and camshafts must be locked in place by the special service tools, otherwise severe engine damage can occur.

CAUTION: During engine repair procedures, cleanliness is extremely important. Any foreign material, including any material created while cleaning gasket surfaces, that enters the oil passages, coolant passages or the oil pan can cause engine failure.

1. Remove the crankshaft pulley. For additional information, refer to Lower End Components - Exploded View and Crankshaft Pulley.

CAUTION: Use care not to damage the engine front cover or the crankshaft when removing the seal.

2. Using the special tool, remove the crankshaft front oil seal.

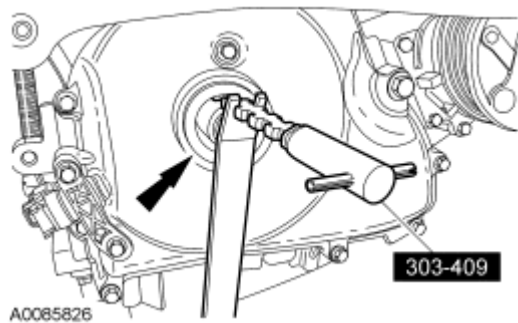

Fig. 79: Locating Crankshaft Front Oil Seal And Special Tool (303-409)
Courtesy of FORD MOTOR CO.

INSTALLATION

NOTE: Remove the through-bolt from the special tool.

NOTE: Lubricate the oil seal with clean engine oil.

1. Using the special tool, install the crankshaft front oil seal.

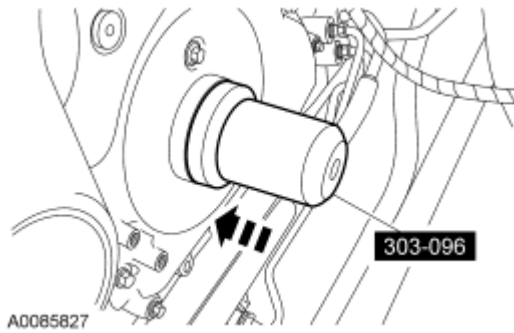



Fig. 80: Installing Crankshaft Front Oil Seal Using Special Tool (303-096)
 Courtesy of FORD MOTOR CO.

2. Install the crankshaft pulley. For additional information, refer to **Lower End Components - Exploded View** and **Crankshaft Pulley**.

FLEXPLATE

Special Tools

Illustration	Tool Name	Tool Number
 <p>ST2768-A</p>	Locking Tool, Flexplate	303-103 (T74P-8375-A)

REMOVAL

1. With the vehicle in NEUTRAL, position it on a hoist. For additional information, refer to **JACKING AND LIFTING** article.
2. Remove the transaxle. For additional information, refer to **AUTOMATIC TRANSAXLE/TRANSMISSION** article.
3. Install the special tool and remove the 6 flexplate bolts and the flexplate.

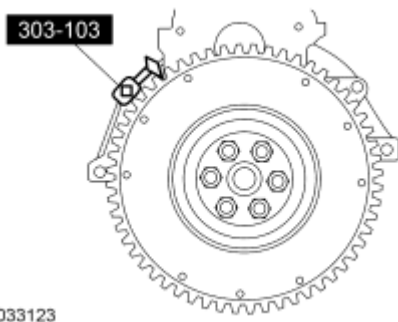
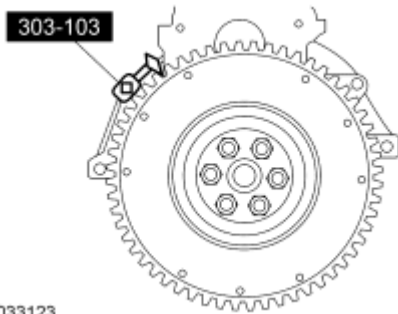

Fig. 81: Identifying Special Tool (303-103)
 Courtesy of FORD MOTOR CO.

INSTALLATION

NOTE: Special bolts are used for installation. Do not use standard bolts.

1. Install the flexplate.
2. Install the special tool.



N0033123

Fig. 82: Identifying Special Tool (303-103)
Courtesy of FORD MOTOR CO.

3. Tighten the bolts in the sequence shown in 3 stages:
 - Stage 1: Tighten to 50 Nm (37 lb-ft).
 - Stage 2: Tighten to 80 Nm (50 lb-ft).
 - Stage 3: Tighten to 112 Nm (83 lb-ft).

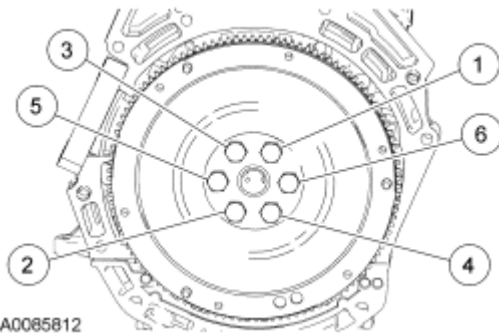

A0085812

Fig. 83: Identifying Flexplate Bolts Tightening Sequence
Courtesy of FORD MOTOR CO.

4. Install the transaxle. For additional information, refer to **AUTOMATIC TRANSAXLE/TRANSMISSION** article.

FLYWHEEL

Special Tools

Illustration	Tool Name	Tool Number

 <p>ST2768-A</p>	<p>Locking Tool, Flywheel</p>	<p>303-103 (T74P-8375-A)</p>
---	-------------------------------	------------------------------

REMOVAL

1. With vehicle in NEUTRAL, position it on a hoist. For additional information, refer to **JACKING AND LIFTING** article.
2. Remove the manual transaxle and clutch. For additional information, refer to **CLUTCH** article and **MANUAL TRANSAXLE/TRANSMISSION** article.
3. Install the special tool and remove the 6 bolts and the flywheel.

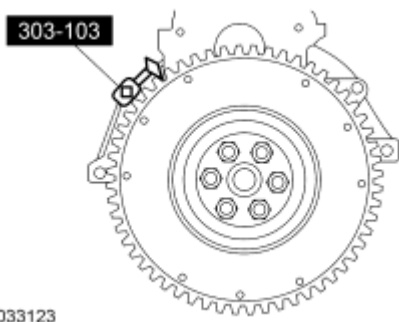

Fig. 84: Identifying Special Tool (303-103)
 Courtesy of FORD MOTOR CO.

INSTALLATION

NOTE: Engine balancing is not required. Balance weights should not be installed on the new flywheel.

NOTE: Special bolts are used for installation. Do not use standard bolts.

1. Inspect the pilot bearing. Install a new pilot bearing as necessary.
2. Install the flywheel and the 6 bolts.
3. Install the special tool.

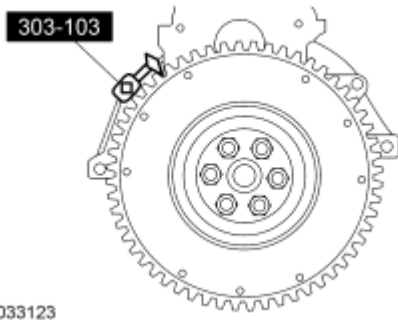

Fig. 85: Identifying Special Tool (303-103)
 Courtesy of FORD MOTOR CO.

NOTE: Special bolts are used for installation. Do not use standard bolts.

4. Tighten the bolts in the sequence shown in 3 stages.
 - Stage 1: Tighten to 50 Nm (37 lb-ft).
 - Stage 2: Tighten to 80 Nm (50 lb-ft).
 - Stage 3: Tighten to 112 Nm (83 lb-ft).

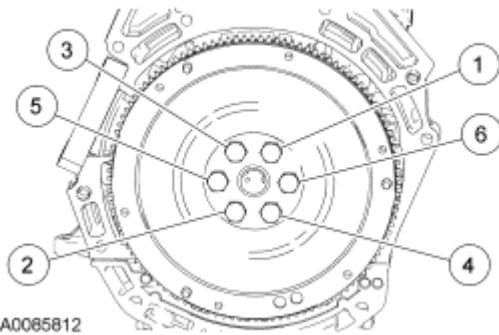



Fig. 86: Identifying Flexplate Bolts Tightening Sequence
 Courtesy of FORD MOTOR CO.

5. Install the clutch and manual transaxle. For additional information, refer to **CLUTCH** article and **MANUAL TRANSAXLE/TRANSMISSION** article.

CRANKSHAFT REAR SEAL WITH RETAINER PLATE

Special Tools

Illustration	Tool Name	Tool Number
 <p>ST1506-A</p>	Installer, Crankshaft Rear Main Oil Seal	303-328 (T88P-6701-B1)

Material

Item	Specification
Motorcraft Metal Surface Prep ZC-31	-
Motorcraft SAE 5W-20 Premium Synthetic Blend Motor Oil XO-5W20-QSP (US); Motorcraft SAE 5W-20 Super Premium Motor Oil CXO-5W20-LSP12 (Canada); or equivalent	WSS-M2C930-A
Silicone Gasket and Sealant TA-30	WSE-M4G323-A4

REMOVAL

1. With the vehicle in NEUTRAL, position it on a hoist. For additional information, refer to **JACKING AND LIFTING** article.
2. Remove the flywheel or flexplate. For additional information, refer to **Flywheel** or **Flexplate**.
3. Drain the engine oil.
 - Install the drain plug and tighten to 28 Nm (21 lb-ft).
4. Remove the oil level indicator and tube. For additional information, refer to **Oil Level Indicator and Tube**.

CAUTION: If the oil pan is not removed damage to the rear oil seal retainer joint can occur.

5. Remove the 17 bolts and the oil pan.
6. Remove the 6 bolts and the crankshaft rear seal with retainer plate.

INSTALLATION

1. Using the special tool, position the crankshaft rear oil seal with retainer plate onto the crankshaft.

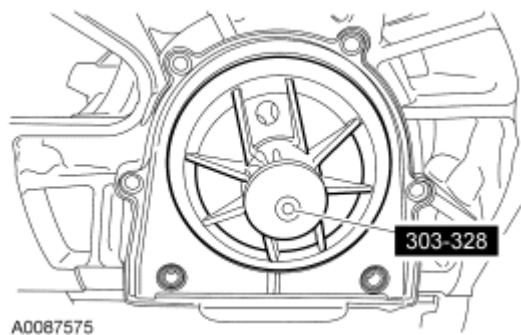

Fig. 87: Identifying Special Tool (303-328)
 Courtesy of FORD MOTOR CO.

2. Install the crankshaft rear seal with retainer plate and 6 bolts.
 - Tighten in the sequence shown to 10 Nm (89 lb-in).

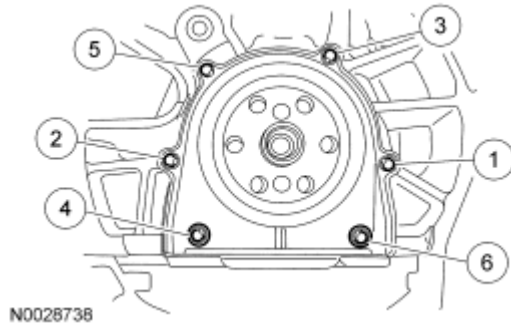

Fig. 88: Identifying Tightening Sequence Of Crankshaft Rear Oil Seal Bolts
Courtesy of FORD MOTOR CO.

CAUTION: Do not use metal scrapers, wire brushes, power abrasive discs or other abrasive means to clean the sealing surfaces. These tools cause scratches and gouges, which make leak paths. Use a plastic scraping tool to remove traces of sealant.

3. Clean and inspect all the oil pan, cylinder block and front cover flange mating surfaces.

NOTE: If the oil pan is not secured within 4 minutes of sealant application, the sealant must be removed and the sealing area cleaned with metal surface prep. Allow to dry until there is no sign of wetness, or 4 minutes, whichever is longer. Failure to follow this procedure can cause future oil leakage.

NOTE: The oil pan must be installed and the bolts tightened within 4 minutes of applying the silicone gasket and sealant.

4. Apply a 2.5 mm (0.10 in) bead of silicone gasket and sealant to the oil pan.
 - Install the oil pan and the 2 bolts finger-tight.

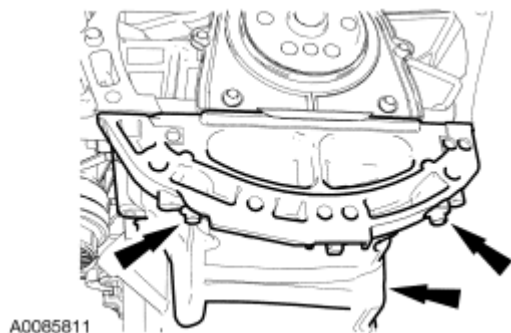

Fig. 89: Identifying Rear Oil Pan Bolts

Courtesy of FORD MOTOR CO.

5. Install the 4 front cover-to-oil pan bolts.
 - Tighten to 10 Nm (89 lb-in).

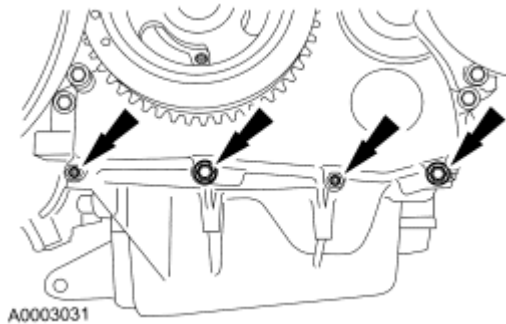

Fig. 90: Locating Bolts
Courtesy of FORD MOTOR CO.

6. Install the remaining oil pan bolts.
 - Tighten in the sequence shown to 25 Nm (18 lb-ft).

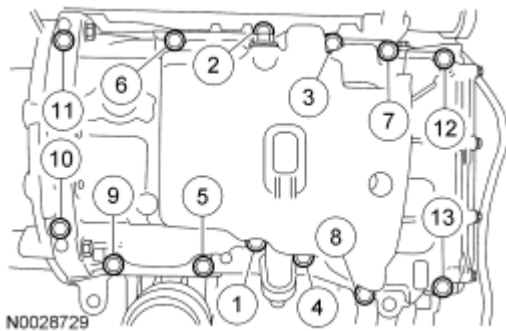

Fig. 91: Identifying Tightening Sequence Of Oil Pan Bolts
Courtesy of FORD MOTOR CO.

7. Install the oil level indicator and tube. For additional information, refer to **Oil Level Indicator and Tube**.
8. Install the flywheel or flexplate. For additional information, refer to **Flywheel** or **Flexplate**.
9. Fill the engine with clean engine oil.





ENGINE FRONT COVER

Special Tools

Illustration	Tool Name	Tool Number
	Remover, Oil Seal	303-409 (T92C-6700-CH)

2007 Ford Focus S

2007 ENGINE Engine - 2.0L and 2.3L - Focus

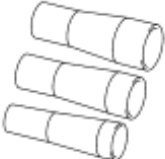
 ST1385-A		
 ST1917-A	Installer, Front Oil Seal	303-096 (T74P-6150-A)
 ST1290-B	Steering Pump Pulley Remover	211-016
 ST1586-A	Steering Pump Pulley Installer	211-185
 ST2787-A	Installer Set, Teflon® Seal	211-D207

Material

Item	Specification
Motorcraft SAE 5W-20 Premium Synthetic Blend Motor Oil XO-5W20-QSP (US); Motorcraft SAE 5W-20 Super Premium Motor Oil CXO-5W20-LSP12 (Canada); or equivalent	WSS-M2C930-A
Silicone Gasket and Sealant TA-30	WSE-M4G323-A4

2007 Ford Focus S

2007 ENGINE Engine - 2.0L and 2.3L - Focus

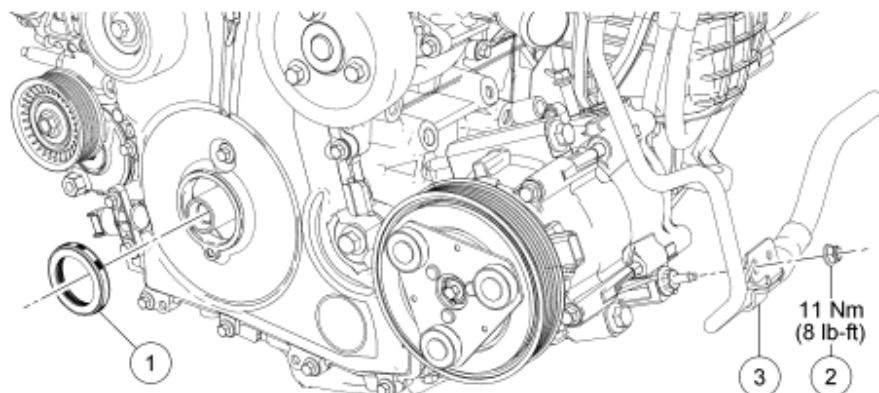

N0059577

Fig. 92: Identifying Engine Front Cover Components (1 Of 2) (With Torque Specifications)
Courtesy of FORD MOTOR CO.

Item	Part Number	Description
1	6700	Crankshaft front seal
2	W520414	Power steering pressure (PSP) tube bracket nut
3	-	PSP tube bracket (part of 3F784)

2007 Ford Focus S

2007 ENGINE Engine - 2.0L and 2.3L - Focus

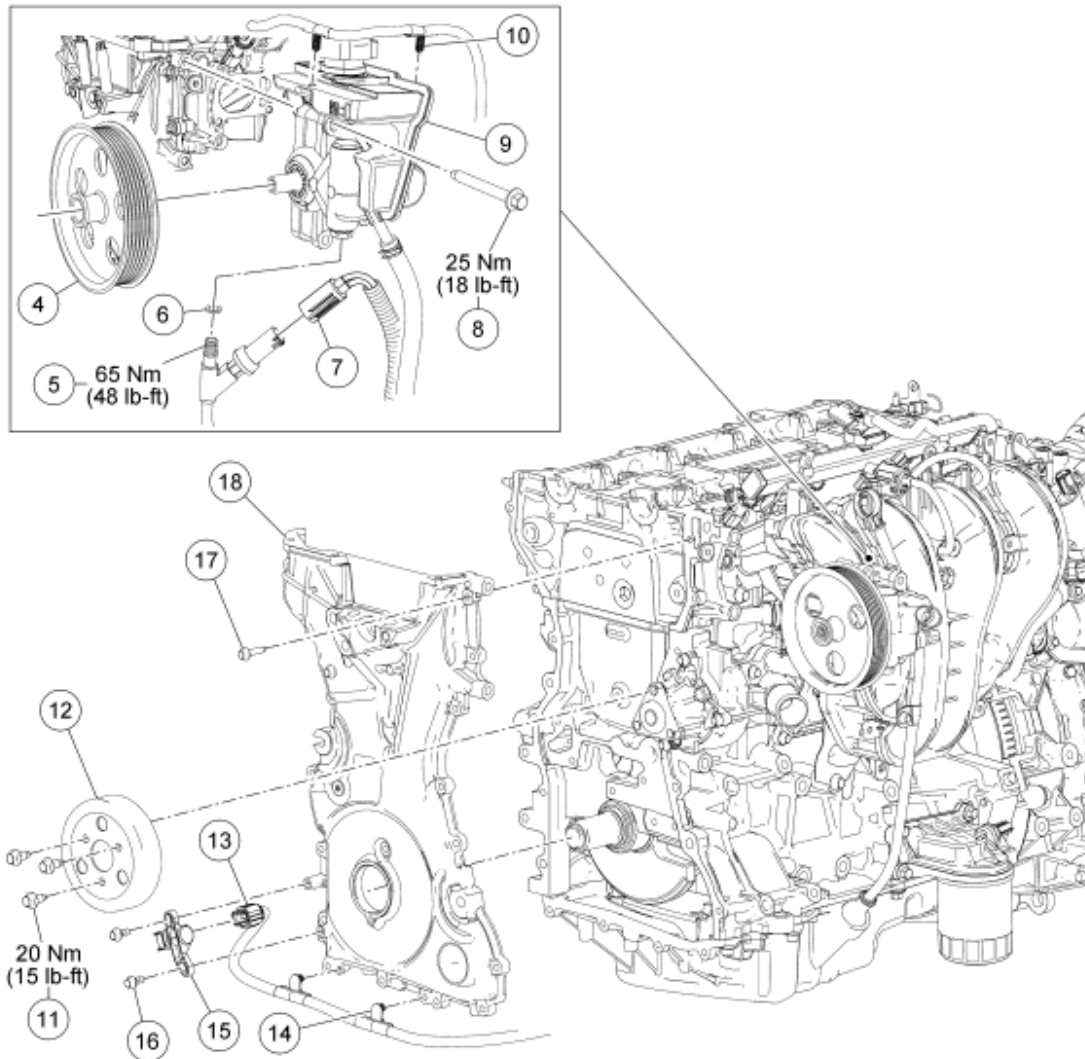

N0059578

Fig. 93: Identifying Engine Front Cover Components (2 Of 2) (With Torque Specifications)
 Courtesy of FORD MOTOR CO.

Item	Part Number	Description
4	3A733	Power steering pulley
5	3F784	PSP tube
6	3F886	Teflon® O-ring seal
7	14A464	PSP switch electrical connector (part of 12B637)
8	W500315	Power steering pump bolt (4 required)
9	3A696	Power steering pump
10	-	Wiring harness retainer (2 required) (part of 12B637)
11	W500221	Coolant pump pulley bolt (3 required)

2007 Ford Focus S

2007 ENGINE Engine - 2.0L and 2.3L - Focus

12	8509	Coolant pump pulley
13	14A464	Crankshaft position (CKP) sensor electrical connector (part of 12B637)
14	-	Wiring harness retainer (2 required) (part of 12B637)
15	6C315	CKP sensor
16	W701219	CKP sensor bolt (2 required)
17	W500215	Engine front cover bolt (22 required)
18	6019	Engine front cover

REMOVAL

CAUTION: Do not loosen or remove the crankshaft pulley bolt without first installing the special tools as instructed in this procedure. The crankshaft pulley and the crankshaft timing sprocket are not keyed to the crankshaft. The crankshaft, the crankshaft sprocket and the pulley are fitted together by friction, using diamond washers between the flange faces on each part. For that reason, the crankshaft sprocket and the pulley are fitted together by friction, using diamond washers between the flange faces on each part. For that reason, the crankshaft sprocket is also unfastened if you loosen the pulley bolt. Before any repair requiring loosening or removal of the crankshaft pulley bolt, the crankshaft and camshafts must be locked in place by the special service tools, otherwise severe engine damage can occur.

CAUTION: During engine repair procedures, cleanliness is extremely important. Any foreign material, including any material created while cleaning gasket surfaces, that enters the oil passages, coolant passages or the oil pan can cause engine failure.

1. With the vehicle in NEUTRAL, position it on a hoist. For additional information, refer to **JACKING AND LIFTING** article.
2. Remove the accessory drive belt and idler pulleys. For additional information, refer to **ACCESSORY DRIVE** article.
3. Remove the crankshaft pulley. For additional information, refer to **Crankshaft Pulley**.
4. Remove the engine mount. For additional information, refer to **Engine Mount**.
5. If equipped, detach the 2 wiring harness retainers from the power steering reservoir.
6. Disconnect the power steering pressure (PSP) switch electrical connector.
7. Using the special tool, remove the power steering pump pulley.

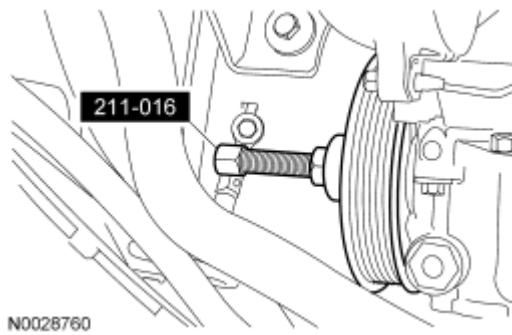

Fig. 94: Removing Power Steering Pump Pulley
Courtesy of FORD MOTOR CO.

8. Remove the PSP tube bracket nut.

NOTE: A new Teflon® O-ring seal must be installed any time the PSP tube is disconnected from the power steering pump.

9. Disconnect the PSP tube from the power steering pump.
 - Remove and discard the Teflon® O-ring seal.
10. Remove the 4 power steering pump mounting bolts and position the power steering pump aside.

CAUTION: Use care not to damage the engine front cover or the crankshaft when removing the seal.

11. Using the special tool, remove the crankshaft front oil seal.

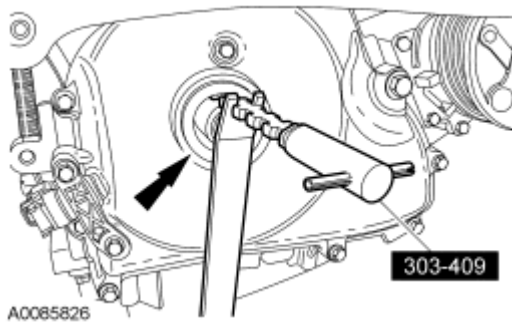

Fig. 95: Locating Crankshaft Front Oil Seal And Special Tool (303-409)
Courtesy of FORD MOTOR CO.

12. Remove the 3 bolts and the coolant pump pulley.
13. Disconnect the crankshaft position (CKP) sensor electrical connector.
 - Detach the 2 wiring harness retainers from the engine front cover.

NOTE: Whenever the CKP sensor is removed, a new part must be installed, using

the alignment jig supplied with the new part.

14. Remove and discard the CKP sensor.
15. Remove the bolts and the engine front cover.

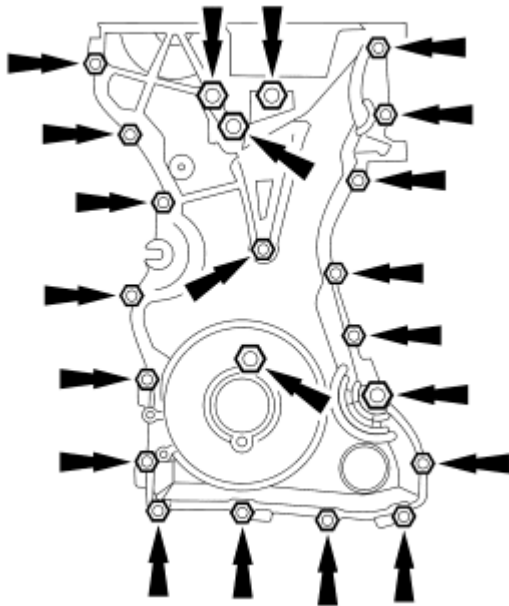

A0087412

Fig. 96: Locating Engine Front Cover Bolts
Courtesy of FORD MOTOR CO.

INSTALLATION

CAUTION: Do not use metal scrapers, wire brushes, power abrasive disks or other abrasive means to clean sealing surfaces. These tools cause scratches and gouges which make leak paths.

1. Clean and inspect the mounting surfaces of the engine and the front cover.

NOTE: The engine front cover must be installed and the bolts tightened within 4 minutes of applying the silicone gasket and sealant.

2. Apply a 2.5 mm (0.10 in) bead of silicone gasket and sealant to the cylinder head and oil pan joint areas. Apply a 2.5 mm (0.10 in) bead of silicone gasket and sealant to the front cover.

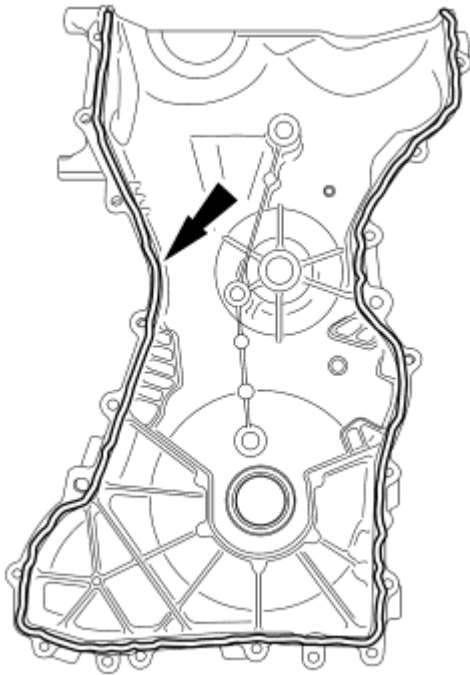

A0032803

Fig. 97: Locating Silicone Gasket
Courtesy of FORD MOTOR CO.

3. Install the engine front cover. Tighten the bolts in the sequence shown, to the following specifications:
 - Tighten the 8-mm bolts to 10 Nm (89 lb-in).
 - Tighten the 13-mm bolts to 48 Nm (35 lb-ft).

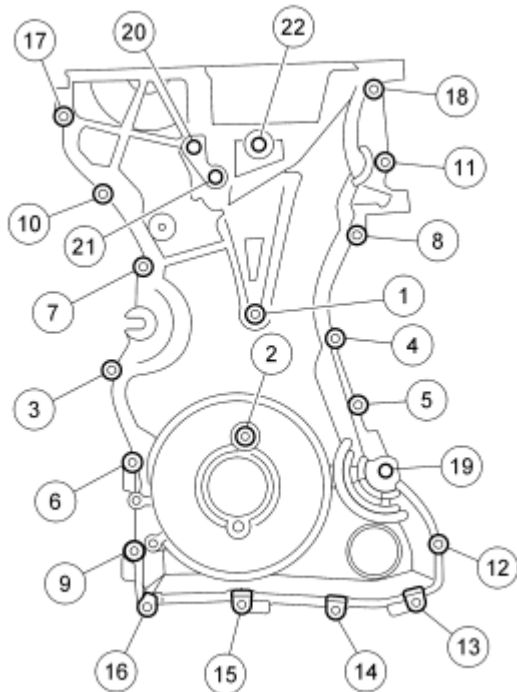

Fig. 98: Identifying Engine Front Cover Bolts Tightening Sequence
 Courtesy of FORD MOTOR CO.

4. Install the coolant pump pulley and the 3 bolts.
 - Tighten to 25 Nm (18 lb-ft).

NOTE: Remove the through-bolt from the special tool.

NOTE: Lubricate the oil seal with clean engine oil.

5. Using the special tool, install the crankshaft front oil seal.

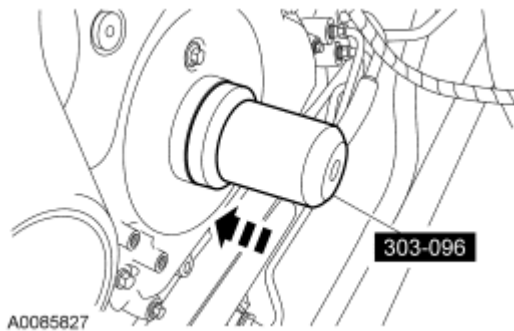

Fig. 99: Installing Crankshaft Front Oil Seal Using Special Tool (303-096)
 Courtesy of FORD MOTOR CO.

6. Install the engine mount. For additional information, refer to **Engine Mount**.

7. Install the crankshaft pulley. For additional information, refer to **Crankshaft Pulley**.

CAUTION: Only hand-tighten the bolt or damage to the front cover can occur.

8. Install a standard 6 mm (0.23 in) x 18 mm (0.7 in) bolt through the crankshaft pulley and thread it into the front cover.

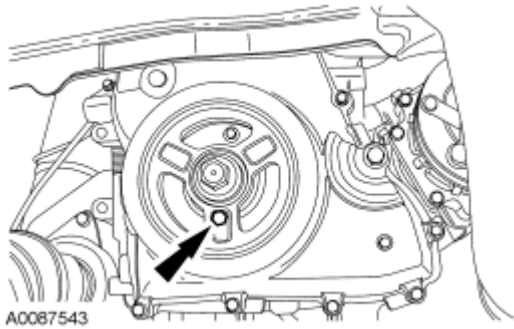

Fig. 100: Aligning Crankshaft Pulley Bolt Holes
Courtesy of FORD MOTOR CO.

9. Install the CKP sensor and the 2 bolts.
 - Do not tighten the bolts at this time.

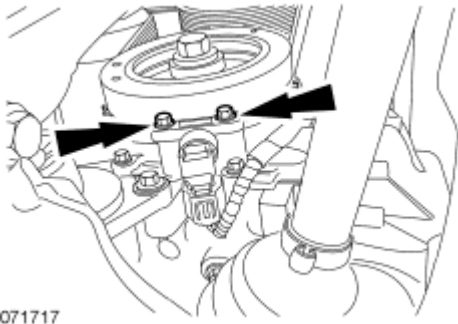

Fig. 101: Locating CKP Sensor Bolts
Courtesy of FORD MOTOR CO.

10. Adjust the new CKP sensor with the alignment jig.
 - Tighten the 2 bolts to 7 Nm (62 lb-in).

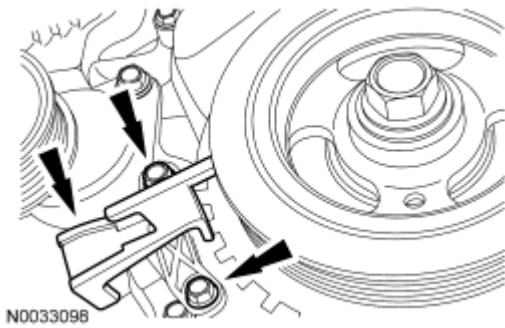

Fig. 102: Locating CKP Sensor Alignment Tool And Bolts
 Courtesy of FORD MOTOR CO.

11. Connect the CKP sensor electrical connector.
 - Attach the 2 wiring harness retainers to the engine front cover.
12. Remove the 6 mm (0.23 in) x 18 mm (0.7 in) bolt.

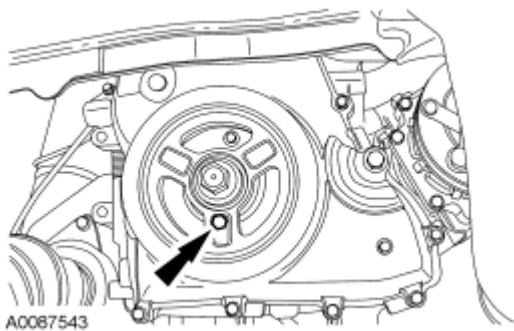
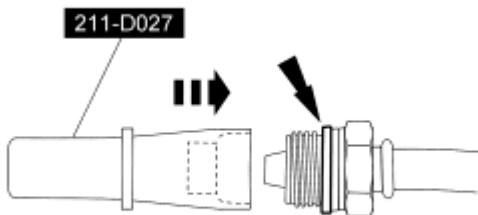

Fig. 103: Aligning Crankshaft Pulley Bolt Holes
 Courtesy of FORD MOTOR CO.

13. Position the power steering pump and install the bolts.
 - Tighten to 25 Nm (18 lb-ft).
14. Using the special tool, install a new Teflon® O-ring seal to the PSP tube.



N0032102

Fig. 104: Installing Teflon(R) Seal Using Special Tool (211-D027)
 Courtesy of FORD MOTOR CO.

15. Install the PSP tube onto the power steering pump.
 - Tighten to 65 Nm (48 lb-ft).
16. Install the PSP tube bracket nut.
 - Tighten to 11 Nm (8 lb-ft).
17. Using the special tool, install the power steering pump pulley.

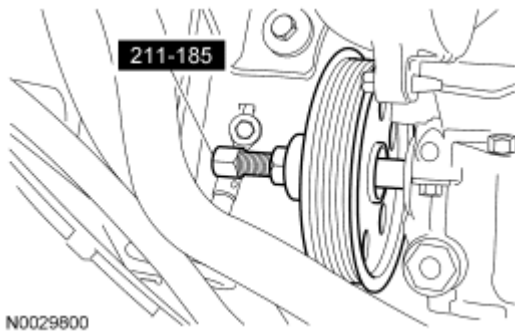



Fig. 105: Installing Power Steering Pump Pulley
 Courtesy of FORD MOTOR CO.

18. Connect the PSP switch electrical connector.
19. If equipped, attach the 2 wiring harness retainers to the power steering reservoir.
20. Install the accessory drive belt and idler pulleys. For additional information, refer to **ACCESSORY DRIVE** article.
21. Fill the power steering system. For additional information, refer to **STEERING SYSTEM - GENERAL INFORMATION** article.

TIMING DRIVE COMPONENTS

Special Tools

Illustration	Tool Name	Tool Number
 <p>ST2645-A</p>	Alignment Plate, Camshaft	303-465 (T94P-6256-CH)

REMOVAL

CAUTION: Do not loosen or remove the crankshaft pulley bolt without first installing the special tools as instructed in this procedure. The crankshaft pulley and the crankshaft timing sprocket are not keyed to the crankshaft. The crankshaft, the crankshaft sprocket and the pulley are fitted together by friction, using diamond washers between the flange faces on each part. For that reason, the crankshaft sprocket is also unfastened if the pulley

bolt is loosened. Before any repair requiring loosening or removal of the crankshaft pulley bolt, the crankshaft and camshafts must be locked in place by the special service tools, otherwise severe engine damage can occur.

CAUTION: During engine repair procedures, cleanliness is extremely important. Any foreign material, including any material created while cleaning gasket surfaces, that enters the oil passages, coolant passages or the oil pan can cause engine failure.

1. With the vehicle in NEUTRAL, position it on a hoist. For additional information, refer to **JACKING AND LIFTING** article.
2. Remove the engine front cover. For additional information, refer to **Engine Front Cover**.
3. Remove the timing chain tensioner.
 1. Compress the timing chain tensioner and insert a paper clip into the hole.
 2. Remove the bolts and timing chain tensioner.

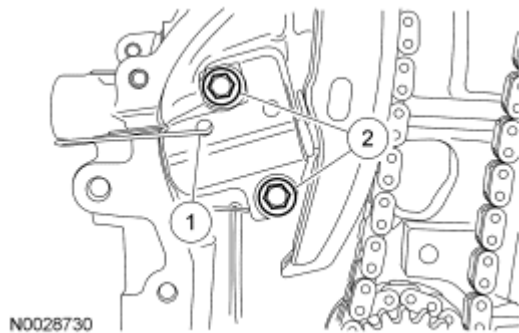

Fig. 106: Identifying Paper Clip Into Hole And Bolts
Courtesy of FORD MOTOR CO.

4. Remove the RH timing chain guide.

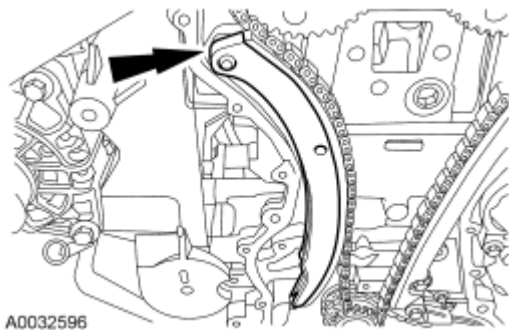

Fig. 107: Locating RH Timing Chain Guide
Courtesy of FORD MOTOR CO.

5. Remove the timing chain.

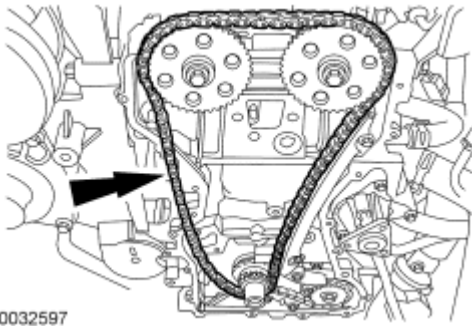

Fig. 108: View Of Timing Chain
Courtesy of FORD MOTOR CO.

6. Remove the bolts and the LH timing chain guide.

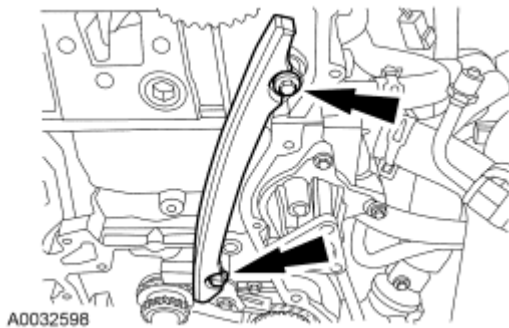

Fig. 109: Identifying Bolts And LH Timing Chain Guide
Courtesy of FORD MOTOR CO.

CAUTION: Do not rely on the Camshaft Alignment Plate to prevent camshaft rotation. Damage to the tool or the camshaft can occur.

NOTE: Intake camshaft drive gear shown, exhaust camshaft drive gear similar.

7. Remove the bolts and the camshaft drive gears.
 - Use the flats on the camshaft to prevent camshaft rotation.

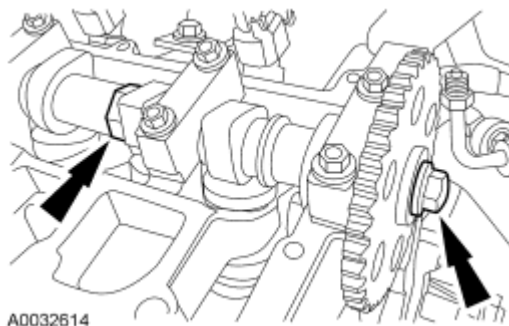

Fig. 110: Locating Cam Holding Area And Sprocket Bolt
 Courtesy of FORD MOTOR CO.

INSTALLATION

1. Install the camshaft drive gears and the bolts. Do not tighten the bolts at this time.

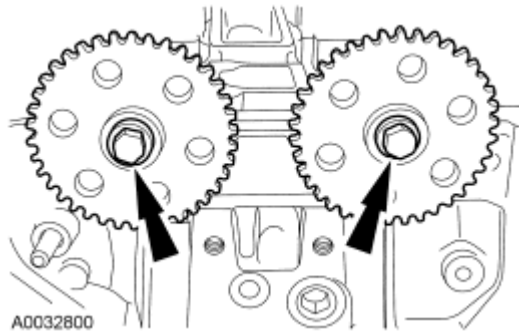

Fig. 111: Locating Camshaft Sprocket Bolts
 Courtesy of FORD MOTOR CO.

2. Install the LH timing chain guide and bolts.
 - Tighten to 10 Nm (89 lb-in).

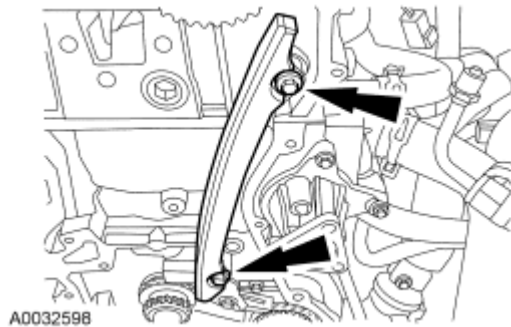

Fig. 112: Identifying Bolts And LH Timing Chain Guide
 Courtesy of FORD MOTOR CO.

3. Install the timing chain.

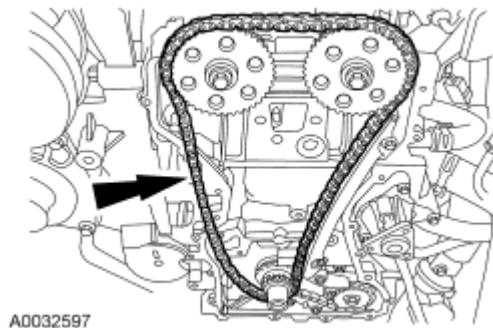

Fig. 113: View Of Timing Chain
Courtesy of FORD MOTOR CO.

4. Install the RH timing chain guide.

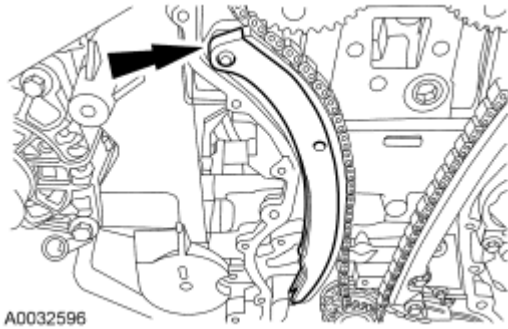

Fig. 114: Locating RH Timing Chain Guide
Courtesy of FORD MOTOR CO.

5. Install the timing chain tensioner and the bolts. Remove the paper clip to release the piston.
 - Tighten to 10 Nm (89 lb-in).

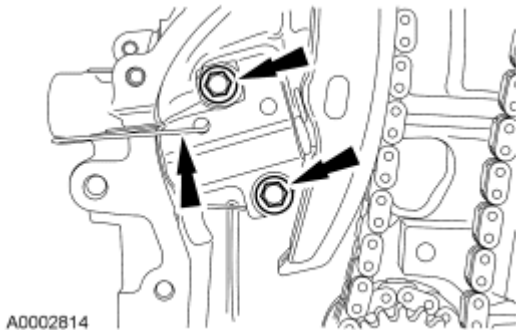

Fig. 115: Locating Timing Chain Tensioner Bolts And Paper Clip
Courtesy of FORD MOTOR CO.

CAUTION: The special tool (303-465) is for camshaft alignment only. Using this tool to prevent engine rotation can result in engine damage.

6. Using the flats on the camshafts to prevent camshaft rotation, tighten the camshaft drive gears bolts.
 - Tighten to 72 Nm (53 lb-ft).

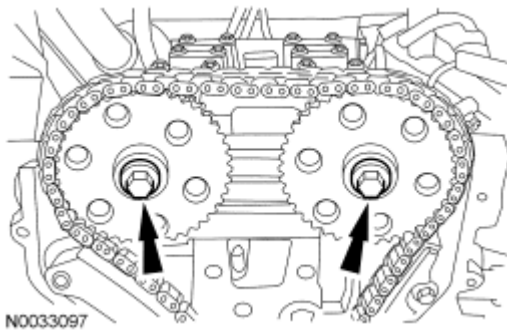



Fig. 116: Locating Camshaft Sprocket Bolts
 Courtesy of FORD MOTOR CO.

7. Install the front cover. For additional information, refer to **Engine Front Cover**.

CAMSHAFTS

Special Tools

Illustration	Tool Name	Tool Number
 ST2645-A	Alignment Plate, Camshaft	303-465 (T94P-6256-CH)
 ST2638-A	Timing Peg, Crankshaft	303-507

Material

Item	Specification
Motorcraft SAE 5W-20 Premium Synthetic Blend Motor Oil XO-5W20-QSP (US); Motorcraft SAE 5W-20 Super Premium Motor Oil CXO-5W20-LSP12 (Canada); or equivalent	WSS-M2C930-A
Silicone Gasket and Sealant TA-30	WSE-M4G323-A4

REMOVAL

CAUTION: During engine repair procedures, cleanliness is extremely important. Any foreign material (including any material created while cleaning gasket surfaces) that enters the oil passages, coolant passages or the oil pan can

cause engine failure.

CAUTION: Do not rotate the camshafts unless instructed to in this procedure. Rotating the camshafts or crankshaft with timing components loosened or removed can cause serious damage to the valves and pistons.

1. With the vehicle in NEUTRAL, position it on a hoist. For additional information, refer to **JACKING AND LIFTING** article.
2. Remove the coolant expansion tank. For additional information, refer to **ENGINE COOLING** article.
3. Remove the RF wheel and tire. For additional information, refer to **WHEELS AND TIRES** article.
4. Check the valve clearance. For additional information, refer to **Valve Clearance Check**.
5. Remove the accessory drivebelt. For additional information, refer to **ACCESSORY DRIVE** article.

CAUTION: Failure to position the No. 1 piston at top dead center (TDC) can result in damage to the engine. Turn the engine in the normal direction of rotation only.

6. Using the crankshaft pulley bolt, turn the crankshaft clockwise to position the No. 1 piston at top dead center (TDC).
 - The hole in the crankshaft pulley should be in the 6 o'clock position.

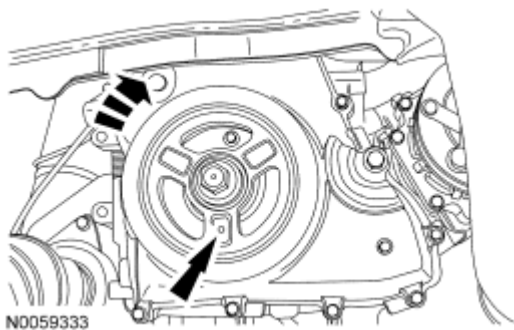

Fig. 117: Turning Crankshaft Clockwise
Courtesy of FORD MOTOR CO.

CAUTION: The special tool (303-465) is for camshaft alignment only. Using this tool to prevent engine rotation can result in engine damage.

NOTE: The camshaft timing slots are offset. If the special tool cannot be installed, rotate the crankshaft one complete revolution clockwise to correctly position the camshafts.

7. Install the special tool in the slots on the rear of both camshafts.

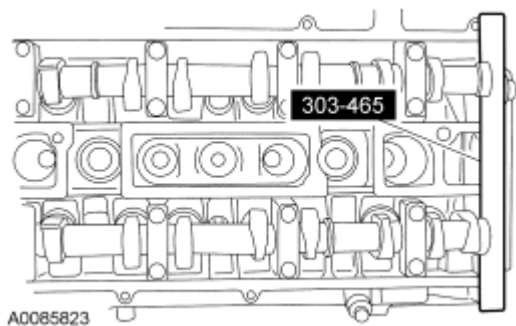

Fig. 118: Identifying Special Camshaft Tool (303-465)
Courtesy of FORD MOTOR CO.

8. Remove the engine plug bolt.

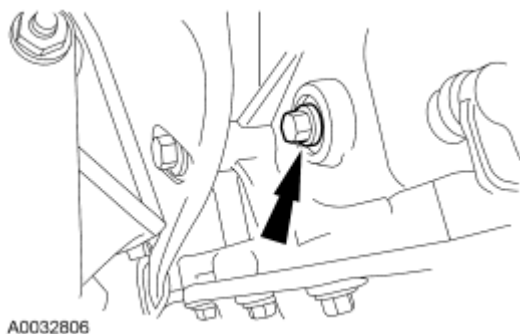

Fig. 119: Locating Engine Plug Bolt
Courtesy of FORD MOTOR CO.

NOTE: The special tool will contact the crankshaft and prevent it from turning past TDC. However, the crankshaft can still be rotated in the counterclockwise direction. The crankshaft must remain at the TDC position during the camshaft removal and installation.

9. Install the special tool.

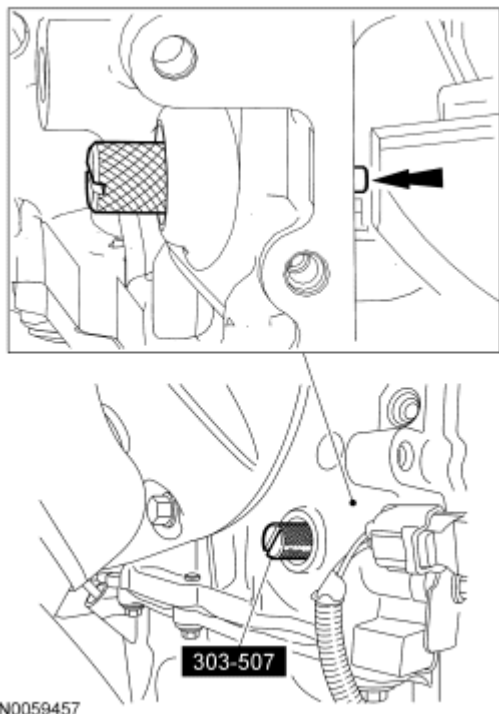

Fig. 120: Identifying Special Tool (303-507)
Courtesy of FORD MOTOR CO.

CAUTION: Only hand-tighten the bolt or damage to the front cover can occur.

10. Install a standard 6 mm (0.23 in) x 18 mm (0.7 in) bolt through the crankshaft pulley and thread it into the front cover.

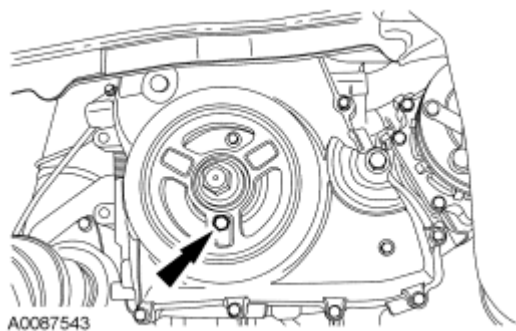

Fig. 121: Aligning Crankshaft Pulley Bolt Holes
Courtesy of FORD MOTOR CO.

11. Remove the front cover lower timing hole plug from the engine front cover.

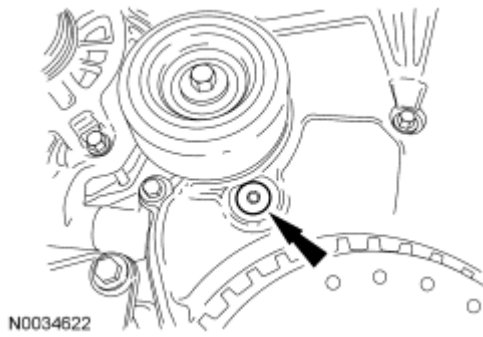

Fig. 122: Locating Lower Front Cover Timing Hole Plug
 Courtesy of FORD MOTOR CO.

12. Remove the front cover upper timing hole plug from the engine front cover.

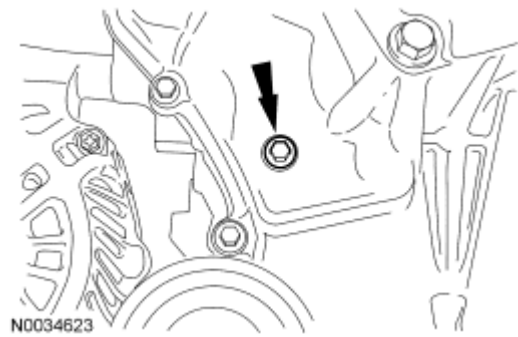

Fig. 123: Locating Upper Front Cover Timing Hole Plug
 Courtesy of FORD MOTOR CO.

13. Reposition the special tool to the slot on the rear of the intake camshaft only.

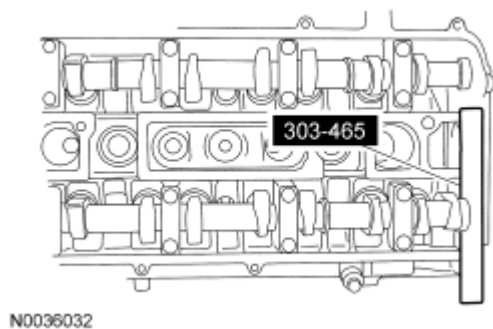
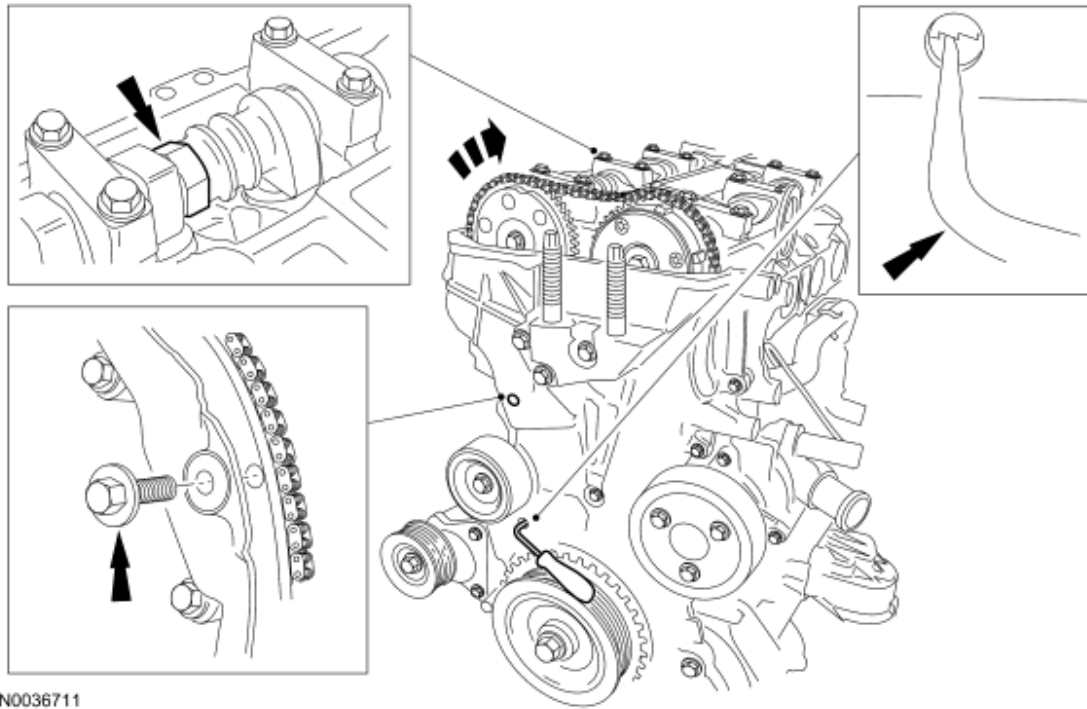

Fig. 124: Identifying Special Tool (303-465)
 Courtesy of FORD MOTOR CO.

NOTE: Releasing the ratcheting mechanism in the timing chain tensioner allows the plunger to collapse and create slack in the timing chain. Installing an M6 x 30 mm (1.18 in) bolt into the upper front cover timing hole will hold the tensioner arm in a retracted position and allow enough slack in the

timing chain for removal of the exhaust camshaft gear.

14. Using a small pick tool, unlock the chain tensioner ratchet through the lower front cover timing hole.
- Using the flats of the camshaft, have an assistant rotate the exhaust camshaft clockwise to collapse the timing chain tensioner plunger.
 - Insert an M6 x 30 mm (1.18 in) bolt into the upper front cover timing hole to hold the tensioner arm in place.



N0036711

Fig. 125: Unlocking Chain Tensioner Ratchet Through Lower Front Cover Timing Hole
Courtesy of FORD MOTOR CO.

15. Remove the special tool.

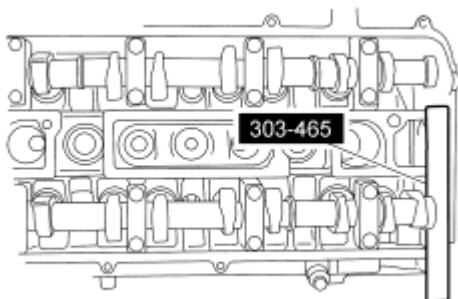

N0036032

Fig. 126: Identifying Special Tool (303-465)
Courtesy of FORD MOTOR CO.

- Using the flats on the camshaft to prevent camshaft rotation, remove the bolt and exhaust camshaft drive gear.

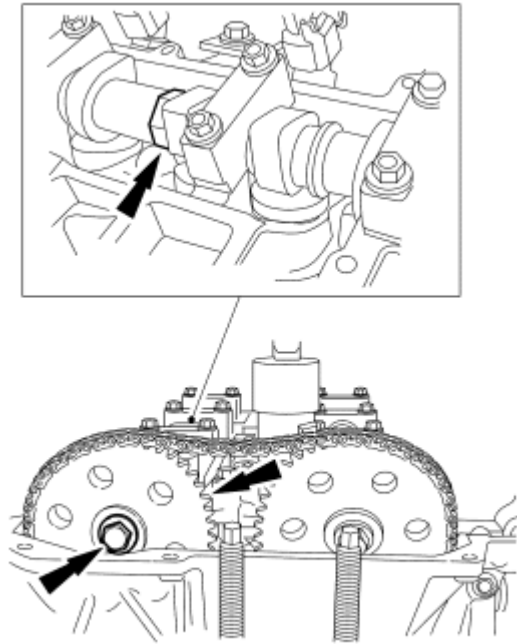

N0039584

Fig. 127: Locating Camshaft Bolt, Bolt And Exhaust Camshaft Drive Gear
Courtesy of FORD MOTOR CO.

- Remove the timing chain from the intake camshaft drive gear.

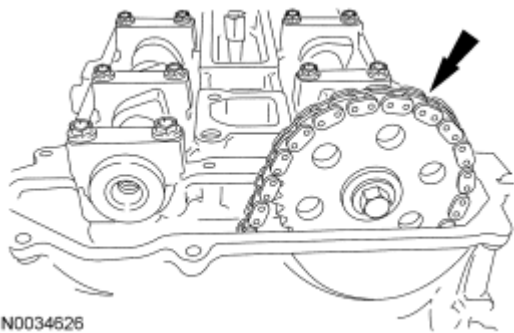

N0034626

Fig. 128: Locating Timing Chain
Courtesy of FORD MOTOR CO.

- Using the flats on the camshaft to prevent camshaft rotation, remove the bolt and intake camshaft drive gear.

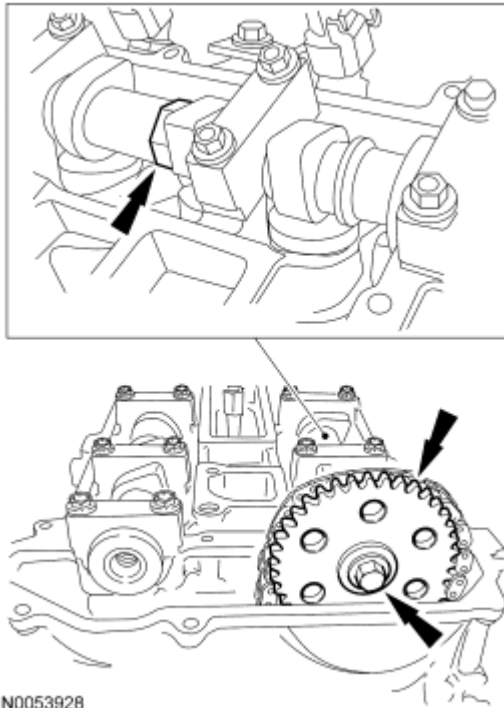

Fig. 129: Locating Camshaft Bolt And Intake Camshaft Drive Gear
Courtesy of FORD MOTOR CO.

19. Mark the position of the camshaft lobes on the No. 1 cylinder for installation reference.

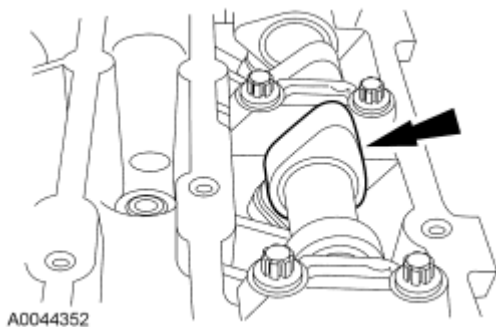

Fig. 130: Locating Camshaft Lobe
Courtesy of FORD MOTOR CO.

CAUTION: Failure to follow the camshaft loosening procedure can result in damage to the camshafts.

NOTE: Mark the location and orientation of each camshaft bearing cap.

20. Remove the camshafts from the engine.
- Loosen the camshaft bearing cap bolts, in sequence, one turn at a time.

- Repeat the first step until all tension is released from the camshaft bearing caps.
- Remove the camshaft bearing caps.
- Remove the camshafts.

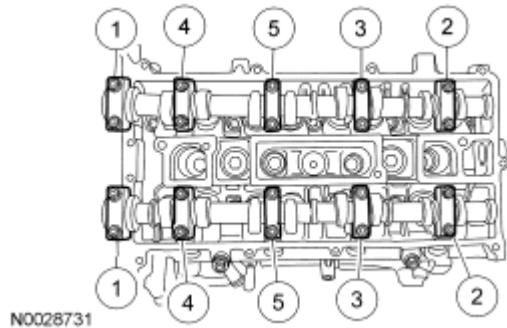

Fig. 131: Identifying Loosening/Tightening Sequence Of Camshaft Bearing Bolts
Courtesy of FORD MOTOR CO.

INSTALLATION

CAUTION: Install the camshafts with the alignment slots in the camshafts lined up so the Camshaft Alignment Plate can be installed without rotating the camshafts. Make sure the lobes on the No. 1 cylinder are in the same position as noted in the removal procedure. Rotating the camshafts when the timing chain is removed, or installing the camshafts 180 degrees out of position can cause severe damage to the valves and pistons.

NOTE: Lubricate the camshaft journals and bearing caps with clean engine oil.

1. Install the camshafts and bearing caps in their original location and orientation. Tighten the bearing caps in the sequence shown in 3 stages:
 - Stage 1: Tighten the camshaft bearing cap bolts one turn at a time until finger tight.
 - Stage 2: Tighten to 7 Nm (62 lb-in).
 - Stage 3: Tighten to 16 Nm (12 lb-ft).

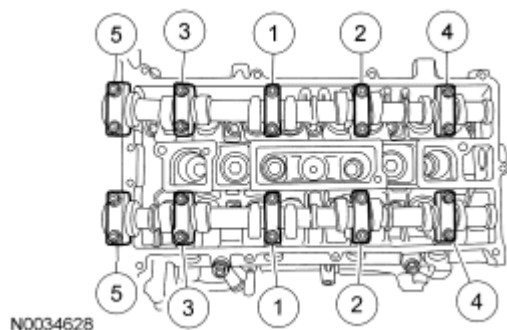

Fig. 132: Identifying Camshaft Bearing Cap Bolts Tightening Sequence

Courtesy of FORD MOTOR CO.

2. Install the special tool.

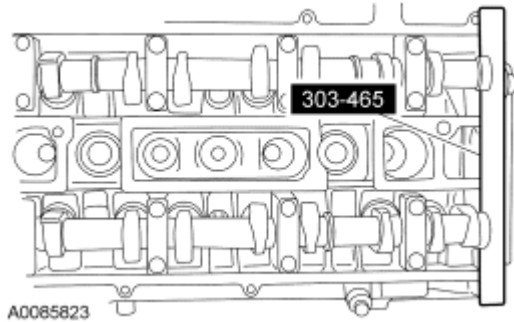

Fig. 133: Identifying Special Camshaft Tool (303-465)
Courtesy of FORD MOTOR CO.

3. Install the intake camshaft drive gear and hand-tighten the bolt.

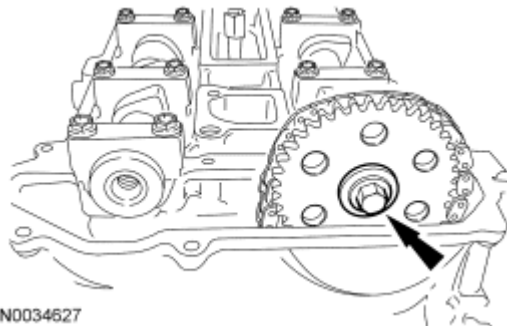

Fig. 134: Locating Intake Camshaft Drive Gear Bolt
Courtesy of FORD MOTOR CO.

4. Install the timing chain on the intake camshaft drive gear.

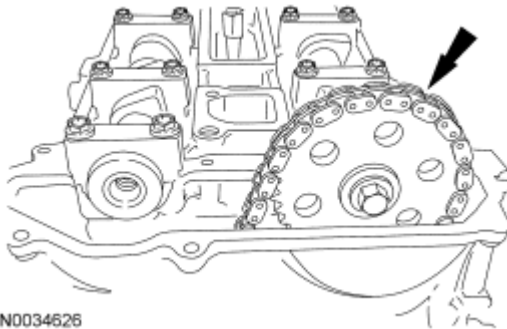

Fig. 135: Locating Timing Chain
Courtesy of FORD MOTOR CO.

NOTE: The timing chain must be correctly engaged on the teeth of the crankshaft timing sprocket and the intake camshaft drive gear in order to install the exhaust camshaft drive gear onto the exhaust camshaft.

5. Position the exhaust camshaft drive gear in the timing chain and install the gear and bolt on the exhaust camshaft.
 - Hand-tighten the bolt.

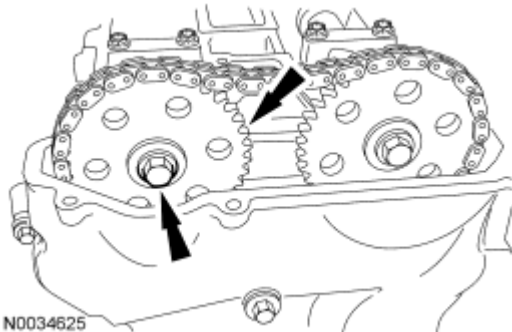

Fig. 136: Locating Exhaust Camshaft Drive Gear Bolt
Courtesy of FORD MOTOR CO.

NOTE: Releasing the tensioner arm will remove the slack from the timing chain release.

6. Remove the M6 x 30 mm bolt from the upper front cover timing hole to unlock the tensioner arm.

CAUTION: The special tool (303-465) is for camshaft alignment only. Using this tool to prevent engine rotation can result in engine damage.

7. Using the flats on the camshafts to prevent camshaft rotation, tighten the camshaft drive gear bolts.
 - Tighten to 72 Nm (53 lb-ft).

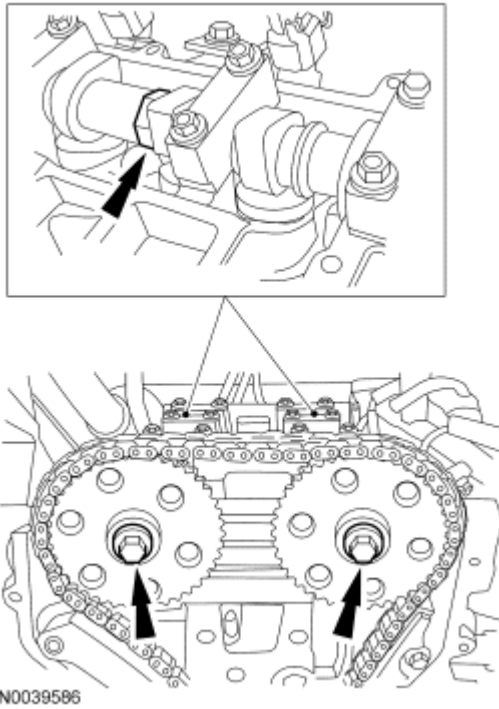

Fig. 137: Locating Camshaft Bolts
Courtesy of FORD MOTOR CO.

8. Remove the special tool.

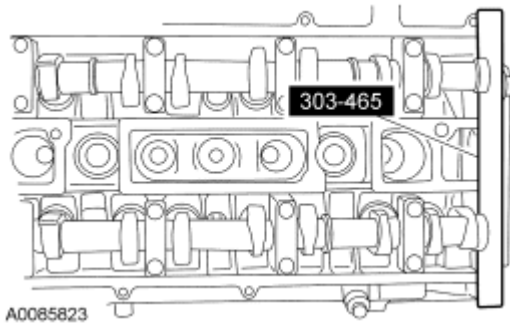

Fig. 138: Identifying Special Camshaft Tool (303-465)
Courtesy of FORD MOTOR CO.

9. Remove the 6 mm (0.23 in) x 18 mm (0.7 in) bolt.

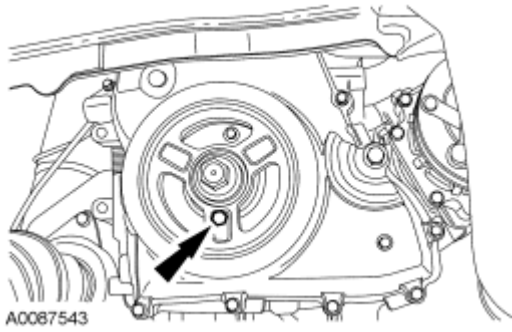

Fig. 139: Aligning Crankshaft Pulley Bolt Holes
Courtesy of FORD MOTOR CO.

10. Remove the special tool.

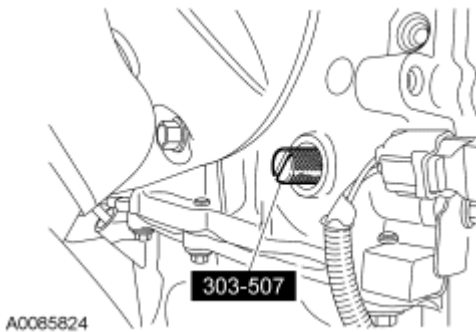

Fig. 140: Identifying Special Tool (303-507)
Courtesy of FORD MOTOR CO.

11. Install the front cover upper timing hole plug.
 - Tighten to 10 Nm (89 lb-in).

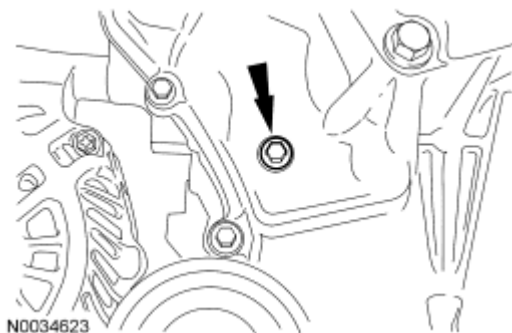

Fig. 141: Locating Upper Front Cover Timing Hole Plug
Courtesy of FORD MOTOR CO.

12. Apply silicone gasket and sealant to the threads of the front cover lower timing hole plug.
 - Install the plug and tighten to 12 Nm (9 lb-ft).

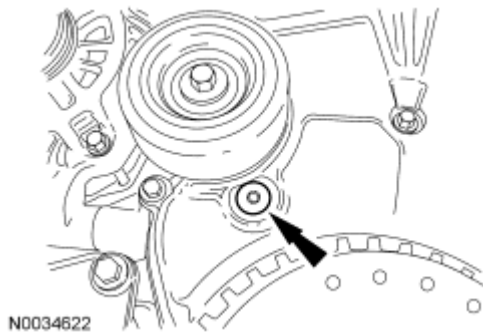

Fig. 142: Locating Lower Front Cover Timing Hole Plug
 Courtesy of FORD MOTOR CO.

13. Install the engine plug bolt.
 - Tighten to 20 Nm (15 lb-ft).

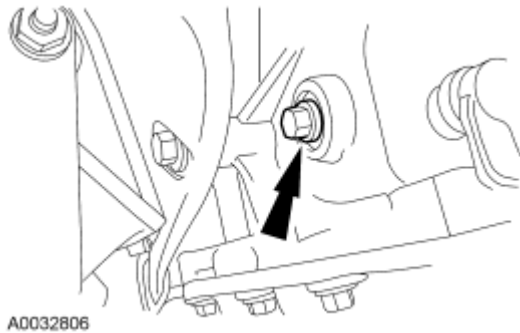

Fig. 143: Locating Engine Plug Bolt
 Courtesy of FORD MOTOR CO.

14. Install the accessory drivebelt. For additional information, refer to [ACCESSORY DRIVE](#) article.
15. Install the RF wheel and tire. For additional information, refer to [WHEELS AND TIRES](#) article.
16. Install the valve cover. For additional information, refer to [Valve Cover](#).
17. Install the coolant expansion tank. For additional information, refer to [ENGINE COOLING](#) article.

VALVE TRAIN COMPONENTS - EXPLODED VIEW

2007 Ford Focus S

2007 ENGINE Engine - 2.0L and 2.3L - Focus

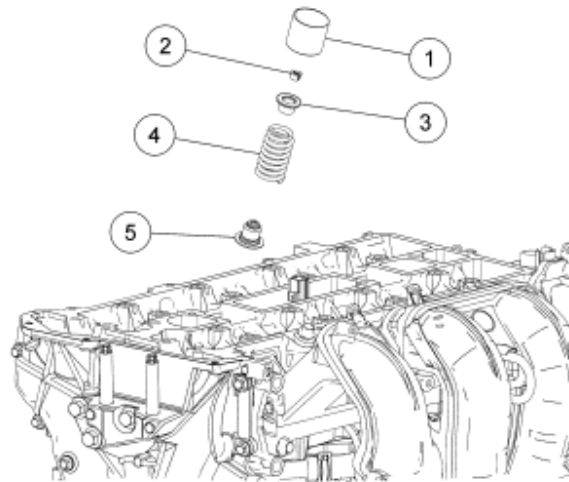

N0039178

Fig. 144: Exploded View Of Valve Train Components
 Courtesy of FORD MOTOR CO.

Item	Part Number	Description
1	6500	Valve tappet (16 required)
2	6518	Valve collet (16 required)
3	6514	Valve spring retainer (16 required)
4	6513	Valve spring (16 required)
5	6517	Valve seal (16 required)

1. For additional information, refer to the appropriate procedures.

VALVE SPRINGS

Special Tools

Illustration	Tool Name	Tool Number
<p>ST1981-F</p>	Compressor, Valve Spring	303-300 (T87C-6565-A)
<p>ST1907-A</p>	Compressor, Valve Spring	303-350 (T89P-6565-A)
	Compressor, Valve Spring	303-472 (T94P-6565-AH)

2007 Ford Focus S

2007 ENGINE Engine - 2.0L and 2.3L - Focus

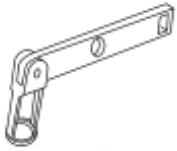

ST1902-A

Material

Item	Specification
Motorcraft SAE 5W-20 Premium Synthetic Blend Motor Oil XO-5W20-QSP (US); Motorcraft SAE 5W-20 Super Premium Motor Oil CXO-5W20-LSP12 (Canada); or equivalent	WSS-M2C930-A
Multi-Purpose Grease XG-4 and/or XL-5	ESB-M1C93-B

REMOVAL

CAUTION: During engine repair procedures, cleanliness is extremely important. Any foreign material, including any material created while cleaning gasket surfaces, that enters the oil passages, coolant passages or the oil pan can cause engine failure.

1. With the vehicle in NEUTRAL, position it on a hoist. For additional information, refer to JACKING AND LIFTING article.
2. Remove the camshafts. For additional information, refer to Camshafts.

NOTE: If the camshafts and valve tappets are to be reused, mark the location of the valve tappets to make sure they are assembled in their original positions.

NOTE: The number on the valve tappets only reflects the digits that follow the decimal. For example, a tappet with the number 0.650 has the thickness of 3.650 mm.

3. Remove and inspect the valve tappets. For additional information, refer to ENGINE SYSTEM - GENERAL INFORMATION article.
4. Remove the spark plugs. For additional information, refer to ENGINE IGNITION - 2.0L AND 2.3L article.

CAUTION: Use compressed air at 7 to 10 bars (100-150 psi). Do not disconnect the compressed air from the cylinder until the valve spring, valve spring retainer and valve collet is installed. Any loss of air pressure will allow the valve to fall into the cylinder.

5. Connect the compressed air supply to cylinder No. 1.

NOTE: Place all parts in order to one side.

6. Apply compressed air to the cylinder and remove the valve spring.
 - Using the special tools, compress the valve spring and remove the valve collet, using some multi-purpose grease and a small screwdriver.
 - Remove the valve spring retainer and the valve spring.

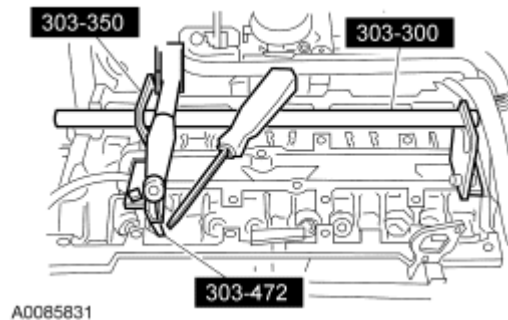

Fig. 145: Identifying Special Tools (303-300, 303-350, 303-472)
Courtesy of FORD MOTOR CO.

INSTALLATION

NOTE: Check the seating of the valve collet.

1. Using the special tools, install the valve spring.
 - Insert the valve spring and the valve spring retainer.
 - Compress the valve spring and install the valve collet using some grease and a small screwdriver.

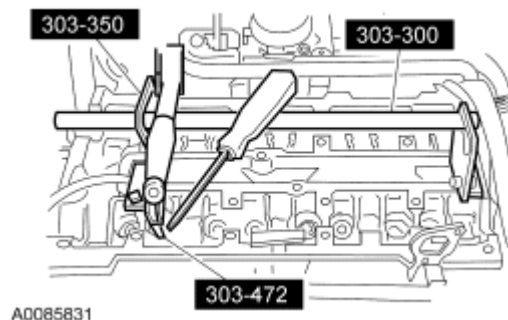

Fig. 146: Identifying Special Tools (303-300, 303-350, 303-472)
Courtesy of FORD MOTOR CO.

2. Disconnect the compressed air supply.

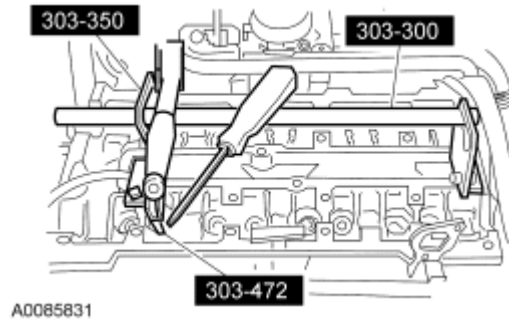

Fig. 147: Identifying Special Tools (303-300, 303-350, 303-472)
 Courtesy of FORD MOTOR CO.

3. Repeat the appropriate removal and installation steps for all of the other cylinders.
4. Install the spark plugs. For additional information, refer to **ENGINE IGNITION - 2.0L AND 2.3L** article.
5. Coat the valve tappets with clean engine oil and insert them.
6. Install the camshafts. For additional information, refer to **Camshafts**.



VALVE SEALS

Special Tools

Illustration	Tool Name	Tool Number
<p>ST1907-A</p>	Compressor, Valve Spring	303-350 (T89P-6565-A)
<p>ST1981-F</p>	Compressor, Valve Spring	303-300 (T87C-6565-A)
<p>ST1902-A</p>	Compressor, Valve Spring	303-472 (T94P-6565-AH)
<p>ST1904-A</p>	Remover, Valve Stem Oil Seal	303-468 (T94P-6510-AH)

2007 Ford Focus S

2007 ENGINE Engine - 2.0L and 2.3L - Focus

 ST1906-A	Installer, Valve Stem Oil Seal	303-470 (T94P-6510-CH)
 ST1187-A	Slide Hammer	307-005 (T59L-100-B)

Material

Item	Specification
Motorcraft SAE 5W-20 Premium Synthetic Blend Motor Oil XO-5W20-QSP (US); Motorcraft SAE 5W-20 Super Premium Motor Oil CXO-5W20-LSP12 (Canada); or equivalent	WSS-M2C930-A
Multi-Purpose Grease XG-4 and/or XL-5	ESB-M1C93-B

REMOVAL

CAUTION: During engine repair procedures, cleanliness is extremely important. Any foreign material, including any material created while cleaning gasket surfaces, that enters the oil passages, coolant passages or the oil pan can cause engine failure.

1. With the vehicle in NEUTRAL, position it on a hoist. For additional information, refer to **JACKING AND LIFTING** article.
2. Remove the camshafts. For additional information, refer to **Camshafts**.

CAUTION: If the camshafts and valve tappets are to be reused, mark the location of the valve tappets to make sure they are assembled in their original positions.

NOTE: The number on the valve tappets only reflects the digits that follow the decimal. For example, a tappet with the number 0.650 has the thickness of 3.650 mm.

3. Remove and inspect the valve tappets. For additional information, refer to **ENGINE SYSTEM - GENERAL INFORMATION** article.
4. Remove the spark plugs. For additional information, refer to **ENGINE IGNITION - 2.0L AND 2.3L** article.

WARNING: Always wear protective goggles when working with compressed air. This can prevent injury. Failure to follow these instructions can result in personal injury.

CAUTION: Use compressed air at 7 to 10 bars (100-150 psi). Do not disconnect the compressed air from the cylinder until the valve spring, valve spring retainer and valve collet is installed.

5. Connect the compressed air supply to the No. 1 cylinder.

NOTE: Place all parts in order to one side.

6. Apply compressed air to the cylinder and remove the valve spring.

- Using the special tools, compress the valve spring and remove the valve collet, using some grease and a small screwdriver.
- Remove the valve spring retainer and the valve spring.

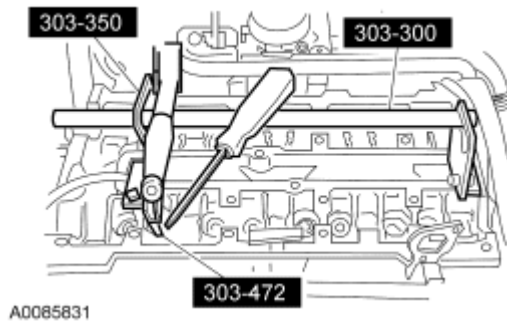

Fig. 148: Identifying Special Tools (303-300, 303-350, 303-472)
Courtesy of FORD MOTOR CO.

7. Using the special tools, remove and discard the valve seal.

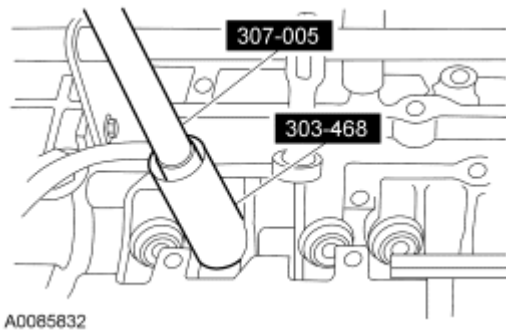
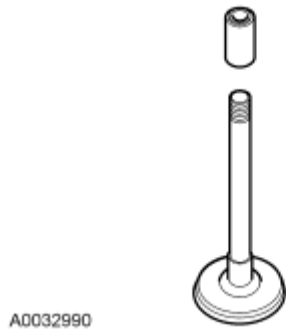

Fig. 149: Identifying Special Tools (307-005, 303-468)
Courtesy of FORD MOTOR CO.

INSTALLATION

1. Install the valve stem seal installation sleeve.



A0032990

Fig. 150: Identifying Valve Stem Seal Installation Sleeve
Courtesy of FORD MOTOR CO.

2. Using the special tool, install the valve seal.

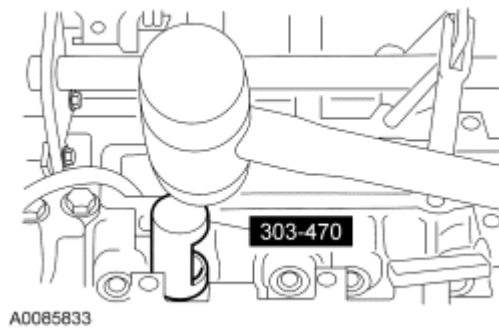

A0085833

Fig. 151: Identifying Special Tool (303-470)
Courtesy of FORD MOTOR CO.

NOTE: Check the seating of the valve collet.

3. Using the special tools, install the valve spring.
 - Insert the valve spring and the valve spring retainer.
 - Compress the valve spring and install the valve collet using some grease and a small screwdriver.

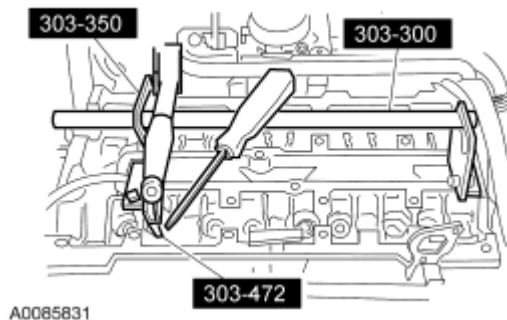

A0085831

Fig. 152: Identifying Special Tools (303-300, 303-350, 303-472)

Courtesy of FORD MOTOR CO.

4. Disconnect the compressed air supply.
5. Repeat the appropriate removal and installation steps for all of the other cylinders.
6. Install the spark plugs. For additional information, refer to **ENGINE IGNITION - 2.0L AND 2.3L** article.
7. Coat the valve tappets with clean engine oil and insert them.
8. Install the camshafts. For additional information, refer to **Camshafts**.

VALVE TAPPETS**Material**

Item	Specification
Motorcraft SAE 5W-20 Premium Synthetic Blend Motor Oil XO-5W20-QSP (US); Motorcraft SAE 5W-20 Super Premium Motor Oil CXO-5W20-LSP12 (Canada); or equivalent	WSS-M2C930-A

REMOVAL AND INSTALLATION

CAUTION: During engine repair procedures, cleanliness is extremely important. Any foreign material, including any material created while cleaning gasket surfaces, that enters the oil passages, coolant passages or the oil pan can cause engine failure.

1. With the vehicle in NEUTRAL, position it on a hoist. For additional information, refer to **JACKING AND LIFTING** article.
2. Remove the camshafts. For additional information, refer to **Camshafts**.

NOTE: If the camshafts and valve tappets are to be reused, mark the location of the valve tappets to make sure they are assembled in their original positions.

NOTE: The number on the valve tappets only reflects the digits that follow the decimal. For example, a tappet with the number 0.650 has the thickness of 3.650 mm.

3. Remove and inspect the valve tappets. For additional information refer to **ENGINE SYSTEM - GENERAL INFORMATION** article.
4. To install, reverse the removal procedure.
 - Coat the valve tappets with clean engine oil prior to installation.

CYLINDER HEAD

2007 Ford Focus S

2007 ENGINE Engine - 2.0L and 2.3L - Focus

Special Tools

Illustration	Tool Name	Tool Number
 ST2645-A	Alignment Plate, Camshaft	303-465 (T94P-6256-CH)

Material

Item	Specification
Motorcraft SAE 5W-20 Premium Synthetic Blend Motor Oil XO-5W20-QSP (US); Motorcraft SAE 5W-20 Super Premium Motor Oil CXO-5W20-LSP12 (Canada); or equivalent	WSS-M2C930-A
Silicone Gasket Remover ZC-30	-
Motorcraft Metal Surface Prep ZC-31	-
Silicone Gasket and Sealant TA-30	WSE-M4G323-A4

2007 Ford Focus S

2007 ENGINE Engine - 2.0L and 2.3L - Focus

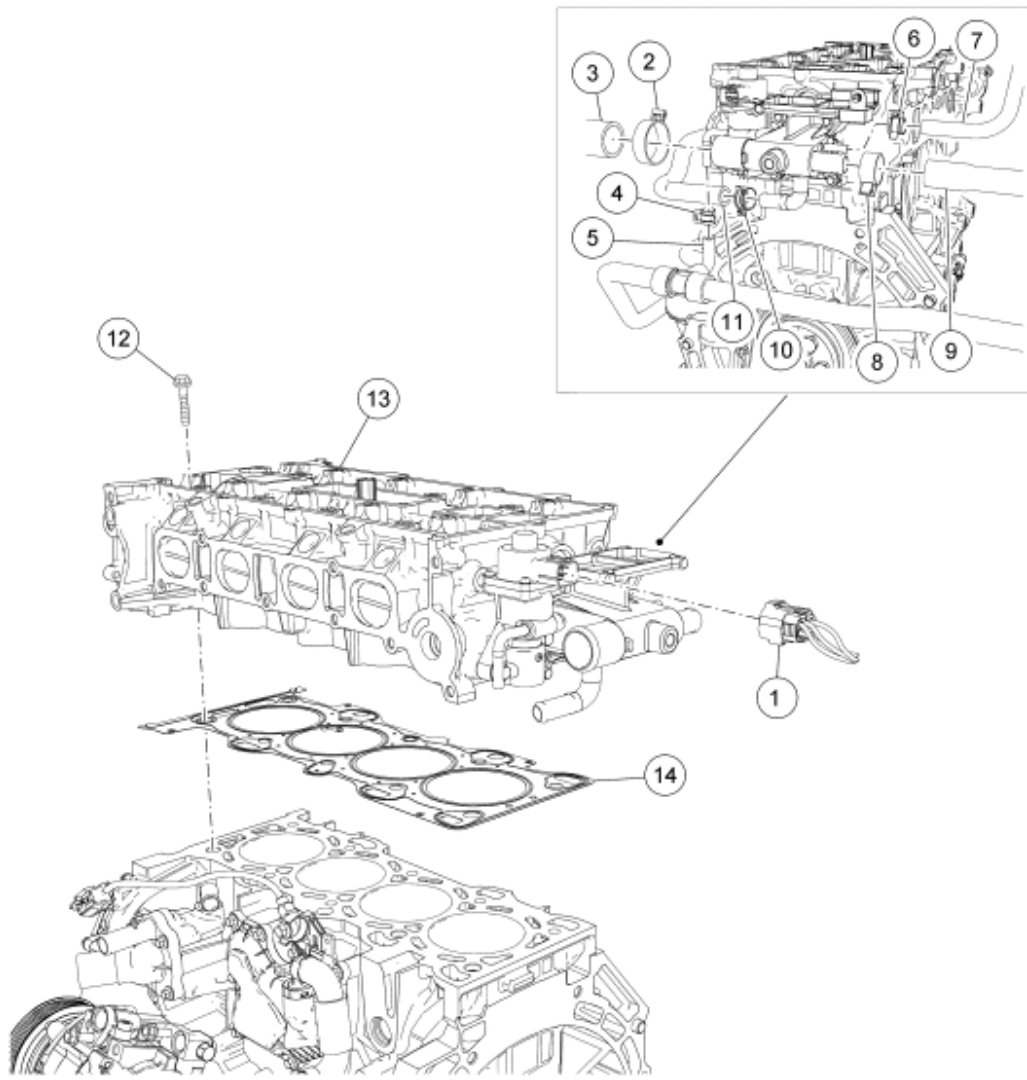

N0045929

Fig. 153: Identifying Cylinder Head Components
 Courtesy of FORD MOTOR CO.

Item	Part Number	Description
1	14A464	Exhaust gas recirculation (EGR) valve electrical connector (part of 12B637)
2	8287	Upper radiator hose clamp
3	8260	Upper radiator hose
4	W52592	EGR coolant tube clamp
5	18K580	EGR coolant hose (part of heater hose)
6	-	Engine coolant vent hose clamp (part of 8W005)
7	8W005	Engine coolant vent hose
8	-	Heater hose clamp (part of 18K580)

2007 Ford Focus S

2007 ENGINE Engine - 2.0L and 2.3L - Focus

9	18K580	Heater hose
10	W525958	Bypass hose clamp
11	8548	Bypass hose
12	6065	Cylinder head bolt (10 required)
13	6050	Cylinder head
14	6051	Cylinder head gasket

REMOVAL

CAUTION: Do not loosen or remove the crankshaft pulley bolt without first installing the special tools as instructed in this procedure. The crankshaft pulley and the crankshaft timing sprocket are not keyed to the crankshaft. The crankshaft, the crankshaft sprocket and the pulley are fitted together by friction, using diamond washers between the flange faces on each part. For that reason, the crankshaft sprocket is also unfastened if the pulley bolt is loosened. Before any repair requiring loosening or removal of the crankshaft pulley bolt, the crankshaft and camshafts must be locked in place by the special service tools, otherwise severe engine damage can occur.

CAUTION: During engine repair procedures, cleanliness is extremely important. Any foreign material, including any material created while cleaning gasket surfaces, that enters the oil passages, coolant passages or the oil pan can cause engine failure.

All engines

1. Release the fuel system pressure. For additional information, refer to **FUEL SYSTEM - GENERAL INFORMATION** article.
2. Remove the battery tray. For additional information, refer to **BATTERY, MOUNTING AND CABLES** article.
3. Drain the cooling system. For additional information, refer to **ENGINE COOLING** article.
4. Check the valve clearance. For additional information, refer to **Valve Clearance Check**.
5. Remove the nuts and disconnect the catalytic converter from the exhaust assembly.
 - Remove and discard the gasket.

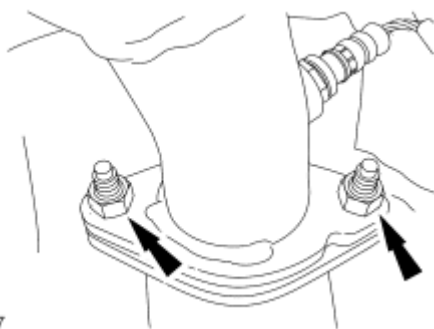

A0093197

Fig. 154: Locating Catalytic Converter Nuts
Courtesy of FORD MOTOR CO.

6. Remove the 2 bolts and the catalytic converter support bracket from the engine.

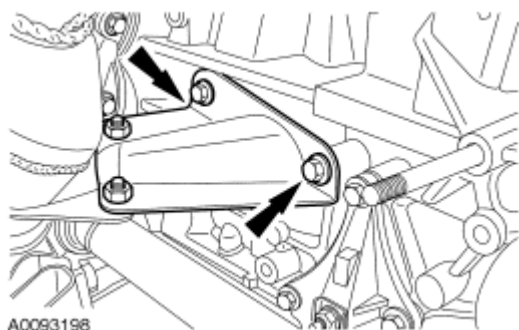

A0093198

Fig. 155: Locating Catalytic Converter Support Bracket And Bolts
Courtesy of FORD MOTOR CO.

NOTE: All 2.3L engines and some 2.0L engines are equipped with a heat shield that must be positioned aside to access the catalytic converter-to-engine nuts.

7. If equipped, remove the 4 heat shield bolts and position the heat shield aside.

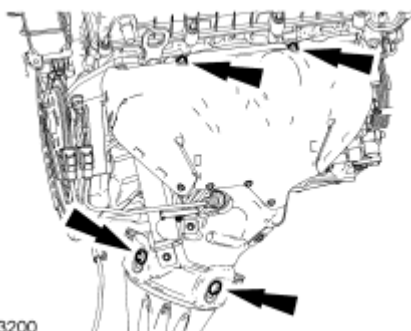

A0093200

Fig. 156: Locating Heat Shield Bolts
Courtesy of FORD MOTOR CO.

8. Disconnect the exhaust sensor electrical connectors.

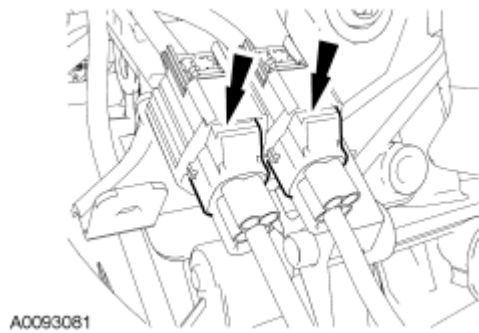

Fig. 157: Locating Electrical Connectors And Wiring Retainers
Courtesy of FORD MOTOR CO.

9. Remove and discard the catalytic converter-to-engine nuts.
 - Position aside the catalytic converter and support with mechanic's wire.
 - Remove and discard the catalytic converter gasket.

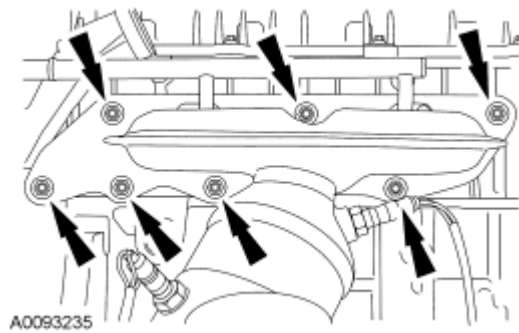

Fig. 158: Locating Catalytic Converter-To-Engine Nuts
Courtesy of FORD MOTOR CO.

10. Remove the generator. For additional information, refer to **GENERATOR AND REGULATOR** article.
11. Remove the fuel injection supply manifold. For additional information, refer to **FUEL CHARGING AND CONTROLS - 2.0L AND 2.3L** article.
12. Remove the intake manifold. For additional information, refer to **Intake Manifold**.
13. Remove the timing drive components. For additional information, refer to **Timing Drive Components**.
14. Remove the special tool.

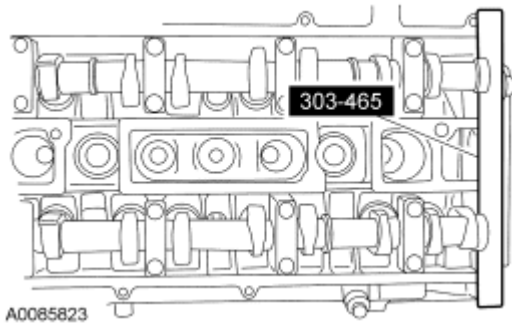

Fig. 159: Identifying Special Camshaft Tool (303-465)
Courtesy of FORD MOTOR CO.

15. Mark the position of the camshaft lobes on the No. 1 cylinder for installation reference.

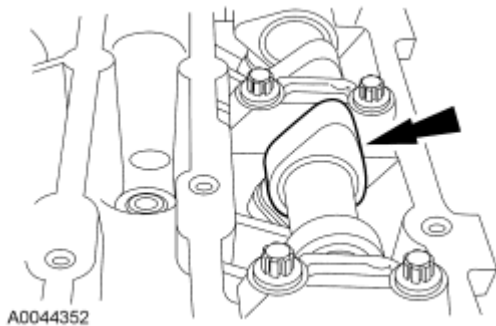

Fig. 160: Locating Camshaft Lobe
Courtesy of FORD MOTOR CO.

CAUTION: Failure to follow the camshaft loosening procedure can result in damage to the camshafts.

NOTE: Mark the location and orientation of each camshaft bearing cap.

16. Remove the camshafts from the engine.
 - Loosen the camshaft bearing cap bolts, in sequence, one turn at a time.
 - Repeat the first step until all tension is released from the camshaft bearing caps.
 - Remove the camshaft bearing caps.
 - Remove the camshafts.

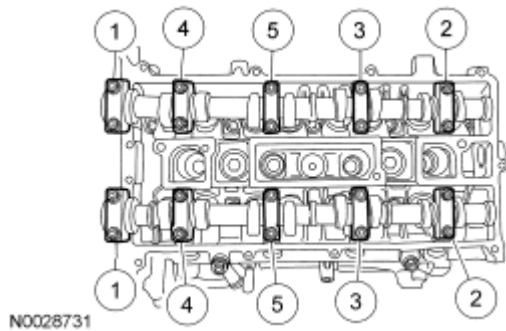

Fig. 161: Identifying Loosening/Tightening Sequence Of Camshaft Bearing Bolts
 Courtesy of FORD MOTOR CO.

CAUTION: If the camshafts and valve tappets are to be reused, mark the location of the valve tappets to make sure they are assembled in their original positions.

17. Remove the valve tappets.

NOTE: The number on the valve tappets only reflects the digits that follow the decimal. For example, a tappet with the number 0.650 has the thickness of 3.650 mm.

18. Inspect the valve tappets. For additional information, refer to [ENGINE SYSTEM - GENERAL INFORMATION](#) article.

2.0L engines

19. If equipped, disconnect the secondary air injection (AIR) vacuum regulator electrical connector and vacuum hose.

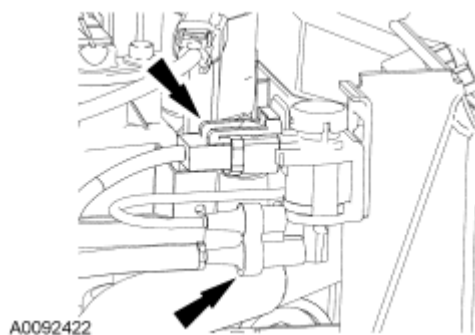

Fig. 162: Locating Secondary Air Injection Vacuum Regulator Electrical Connector And Vacuum Hose
 Courtesy of FORD MOTOR CO.

20. If equipped, disconnect the hoses from the AIR control valve.

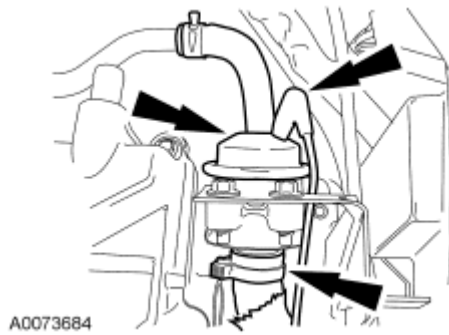

Fig. 163: Locating Secondary Air Injection Vacuum Regulator Electrical Connector And Vacuum Hose
Courtesy of FORD MOTOR CO.

21. If equipped, disconnect the upper exhaust sensor electrical connector and retainer.

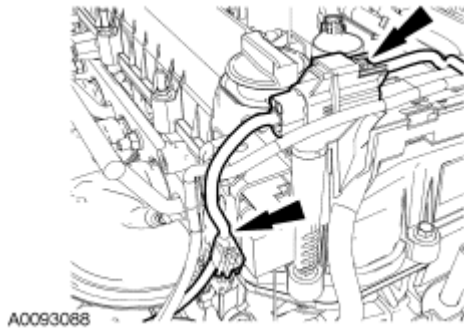

Fig. 164: Locating Electrical Connector And Wiring Retainer
Courtesy of FORD MOTOR CO.

All engines

22. Disconnect the exhaust gas recirculation (EGR) valve electrical connector.
23. Disconnect the coolant hoses from the coolant bypass.
24. Remove the 4 bolts, coolant bypass and gasket.
 - Discard the gasket.
25. Disconnect the EGR coolant hose.
26. Remove the bolts and the cylinder head.
 - Discard the bolts.
27. Remove and discard the head gasket.
28. Inspect the cylinder head mating surfaces. For additional information, refer to **ENGINE SYSTEM - GENERAL INFORMATION** article.

INSTALLATION

All engines

CAUTION: Do not use metal scrapers, wire brushes, power abrasive discs or other abrasive means to clean the sealing surfaces. These tools cause scratches and gouges that make leak paths. Use a plastic scraping tool to remove all traces of the head gasket.

CAUTION: Observe all warnings or cautions and follow all application directions contained on the packaging of the silicone gasket remover and the metal surface prep.

NOTE: If there is no residual gasket material present, metal surface prep can be used to clean and prepare the surfaces.

1. Clean the cylinder head-to-cylinder block mating surface of both the cylinder head and the cylinder block.
 1. Remove any large deposits of silicone or gasket material with a plastic scraper.
 2. Apply silicone gasket remover, following package directions, and allow to set for several minutes.
 3. Remove the silicone gasket remover with a plastic scraper. A second application of silicone gasket remover may be required if residual traces of silicone or gasket material remain.
 4. Apply metal surface prep, following package directions, to remove any traces of oil or coolant, and to prepare the surfaces to bond with the new gasket. Do not attempt to make the metal shiny. Some staining of the metal surfaces is normal.
2. Clean the cylinder head bolt holes in the cylinder block. Make sure all coolant, oil or other foreign material is removed.
3. Inspect the cylinder head for distortion. For additional information, refer to **ENGINE SYSTEM - GENERAL INFORMATION** article.
4. Apply silicone gasket and sealant to the locations shown.

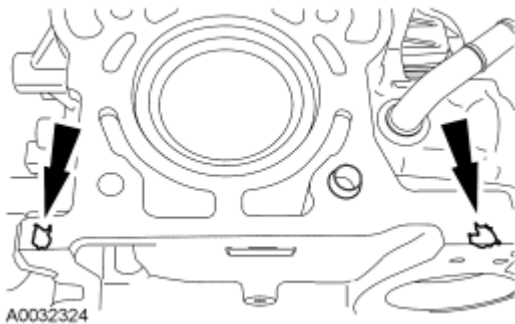

Fig. 165: Identifying Silicone Gasket And Sealant Location
Courtesy of FORD MOTOR CO.

5. Install a new head gasket.

NOTE: The cylinder head bolts are torque-to-yield and must not be reused. New cylinder head bolts must be installed.

NOTE: Lubricate the bolts with clean engine oil prior to installation.

6. Install the cylinder head and 10 new bolts. Tighten the bolts in the sequence shown in 5 stages.
 - Stage 1: Tighten to 5 Nm (44 lb-in).
 - Stage 2: Tighten to 15 Nm (11 lb-ft).
 - Stage 3: Tighten to 45 Nm (33 lb-ft).
 - Stage 4: Turn 90 degrees.
 - Stage 5: Turn an additional 90 degrees.

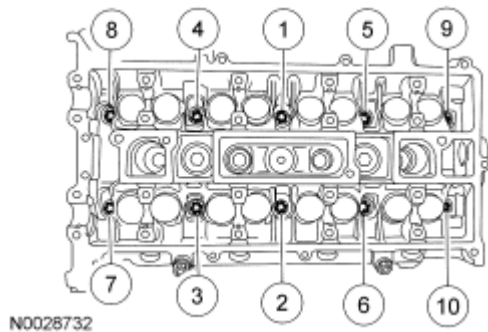
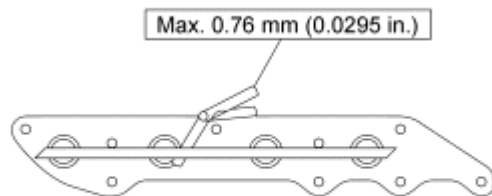

Fig. 166: Identifying Tightening Sequence Of Cylinder Head Bolts
Courtesy of FORD MOTOR CO.

7. Install the EGR coolant hose.
8. Using a new gasket, install the coolant bypass and the 4 bolts.
 - Tighten to 10 Nm (89 lb-in).
9. Connect the coolant hoses onto the coolant bypass.
10. Connect the EGR valve electrical connector.
11. Clean and inspect the catalytic converter flange.
 - Using a straightedge and a feeler gauge, place the straightedge across the catalytic converter flange surface and check for warping with the feeler gauge. If the reading is greater than the maximum specification, install a new catalytic converter, gasket and nuts.



N0033326

Fig. 167: Inspecting Catalytic Converter Flange W/Specs.
Courtesy of FORD MOTOR CO.

12. Using a new gasket and 7 nuts, install the catalytic converter.
 - Tighten to 55 Nm (41 lb-ft).

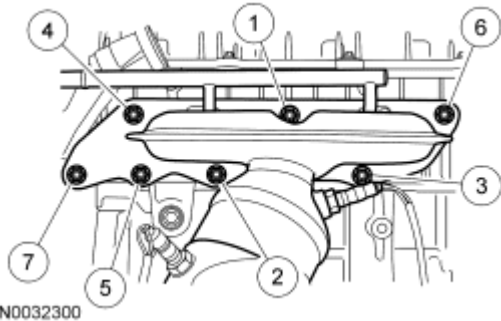

Fig. 168: Locating Catalytic Converter Nuts Tightening Sequence
 Courtesy of FORD MOTOR CO.

13. Connect the exhaust sensor electrical connectors.

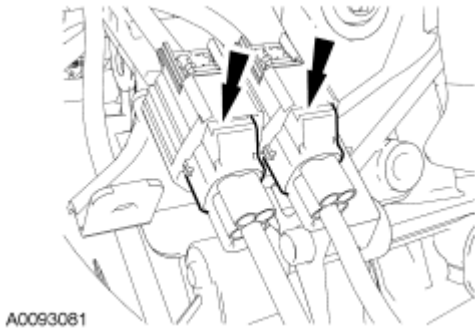
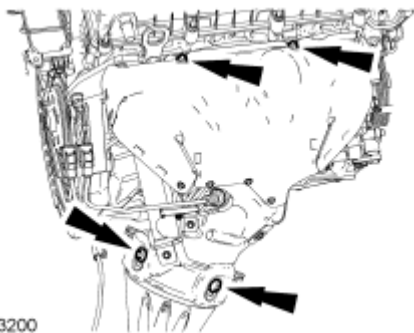

Fig. 169: Locating Electrical Connectors And Wiring Retainers
 Courtesy of FORD MOTOR CO.

NOTE: All 2.3L engines and some 2.0L engines are equipped with a heat shield that must be positioned aside to access the catalytic converter-to engine nuts.

14. If equipped, position the heat shield and install the 4 heat shield bolts.
 - Tighten to 11 Nm (8 lb-ft).



A0093200

Fig. 170: Locating Heat Shield Bolts
 Courtesy of FORD MOTOR CO.

15. Install the catalytic converter support bracket and the 2 bolts to the engine.
 - Tighten to 47 Nm (35 lb-ft).

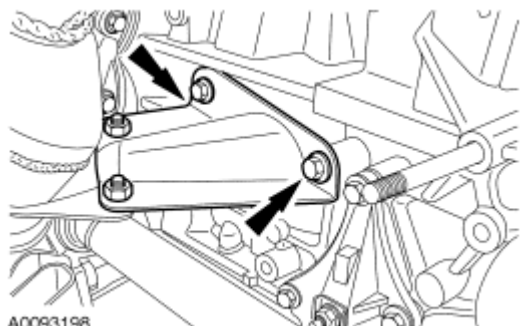

A0093198

Fig. 171: Locating Catalytic Converter Support Bracket And Bolts
 Courtesy of FORD MOTOR CO.

2.0L engines

16. If equipped, connect the upper exhaust sensor electrical connector and retainer.

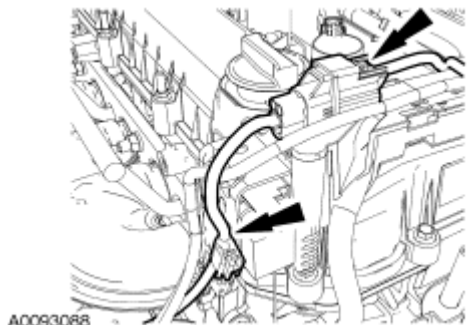

A0093088

Fig. 172: Locating Electrical Connector And Wiring Retainer
 Courtesy of FORD MOTOR CO.

17. If equipped, connect the hoses to the AIR control valve.



Fig. 173: Locating Secondary Air Injection Vacuum Regulator Electrical Connector And Vacuum Hose
Courtesy of FORD MOTOR CO.

18. If equipped, connect the AIR vacuum regulator electrical connector and vacuum hose.

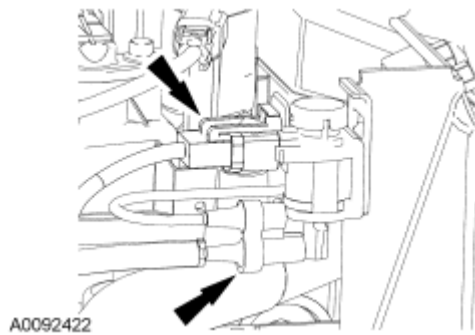

Fig. 174: Locating Secondary Air Injection Vacuum Regulator Electrical Connector And Vacuum Hose
Courtesy of FORD MOTOR CO.

All engines

NOTE: Lubricate the valve tappets with clean engine oil.

19. Install the valve tappets in their original positions.

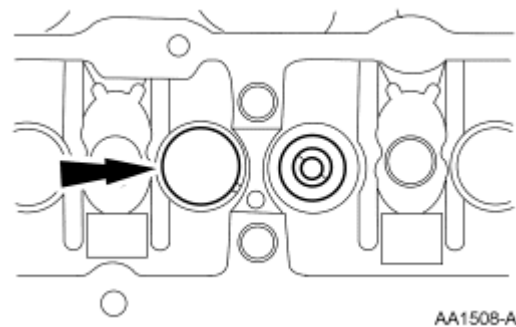

Fig. 175: Locating Valve Tappet

Courtesy of FORD MOTOR CO.

CAUTION: Install the camshafts with the alignment notches in the camshafts lined up so the camshaft alignment plate can be installed. Make sure the lobes on the No. 1 cylinder are in the same position as noted in the removal procedure. Failure to follow this procedure can cause severe damage to the valves and pistons.

NOTE: Lubricate the camshaft journals and bearing caps with clean engine oil.

20. Install the camshafts and bearing caps in their original location and orientation. Tighten the bearing caps in the sequence shown in 3 stages:
- Stage 1: Tighten the camshaft bearing cap bolts, one turn at a time, until the cam is fully seated.
 - Stage 2: Tighten the bolts to 7 Nm (62 lb-in).
 - Stage 3: Tighten the bolts to 16 Nm (12 lb-ft).

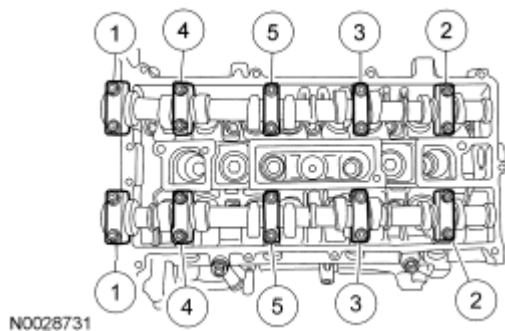
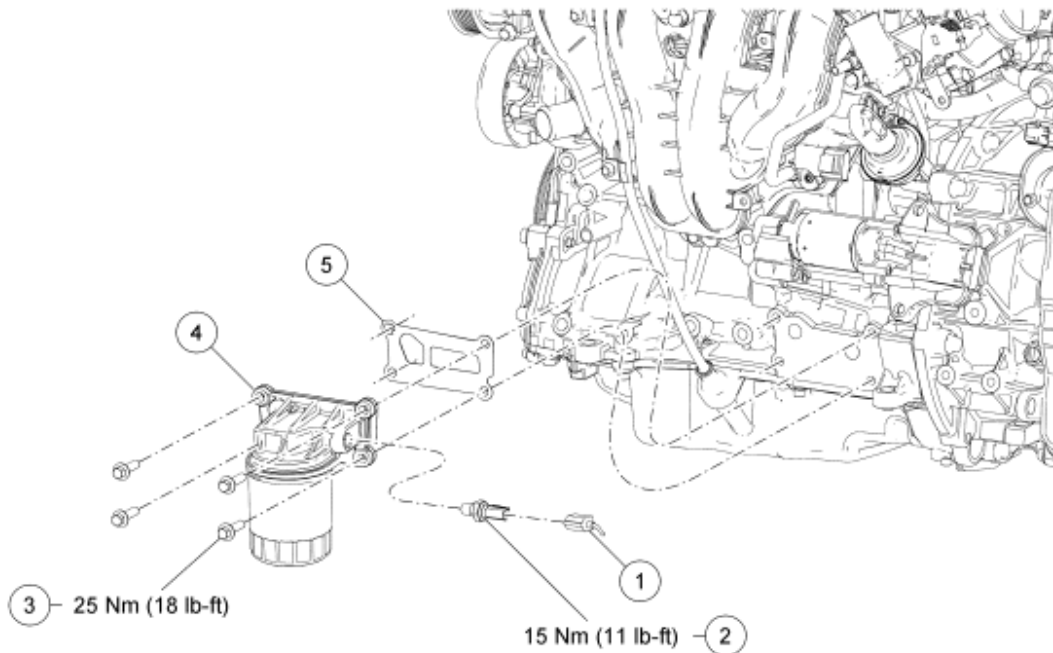

Fig. 176: Identifying Loosening/Tightening Sequence Of Camshaft Bearing Bolts
Courtesy of FORD MOTOR CO.

21. Install the timing drive components. For additional information, refer to **Timing Drive Components**.
22. Install the intake manifold. For additional information, refer to **Intake Manifold**.
23. Install the fuel injector supply manifold. For additional information, refer to **FUEL CHARGING AND CONTROLS - 2.0L AND 2.3L** article.
24. Install the generator. For additional information, refer to **GENERATOR AND REGULATOR** article.
25. Connect the radio interference capacitor electrical connector.
26. Install the dual cooling fans and connect the electrical connectors.
27. Install the battery tray. For additional information, refer to **BATTERY, MOUNTING AND CABLES** article.
28. Drain the engine oil and change the filter.
- Tighten the plug to 28 Nm (21 lb-ft).
29. Fill the engine with clean engine oil.
30. Fill and bleed the cooling system. For additional information, refer to **ENGINE COOLING** article.
31. Fill the power steering system. For additional information, refer to **STEERING SYSTEM - GENERAL**

INFORMATION article.

ENGINE LUBRICATION COMPONENTS - EXPLODED VIEW



N0033373

Fig. 177: Exploded View Of Engine Lubrication Components (1 Of 4) (With Torque Specifications)
 Courtesy of FORD MOTOR CO.

Item	Part Number	Description
1	14A464	Oil pressure sender electrical connector (part of 12 B637)
2	9278	Oil pressure sender
3	W500225	Oil filter adapter bolt (4 required)
4	6881	Oil filter adapter
5	6840	Oil filter adapter gasket

NOTE: Automatic transmission shown, manual transmission similar.

2007 Ford Focus S

2007 ENGINE Engine - 2.0L and 2.3L - Focus

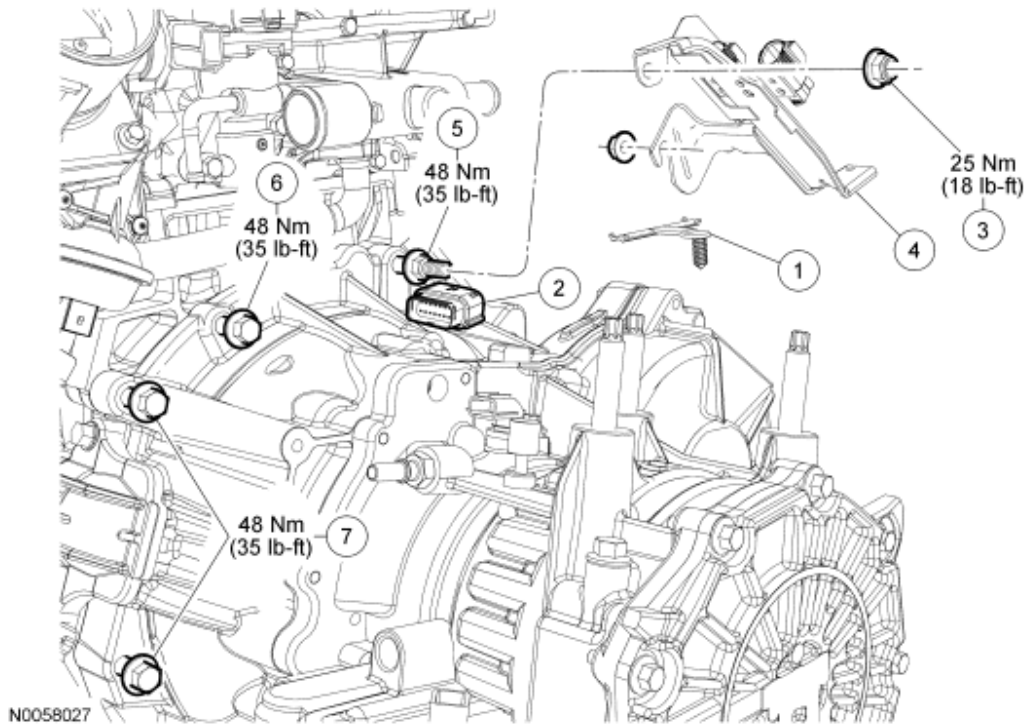
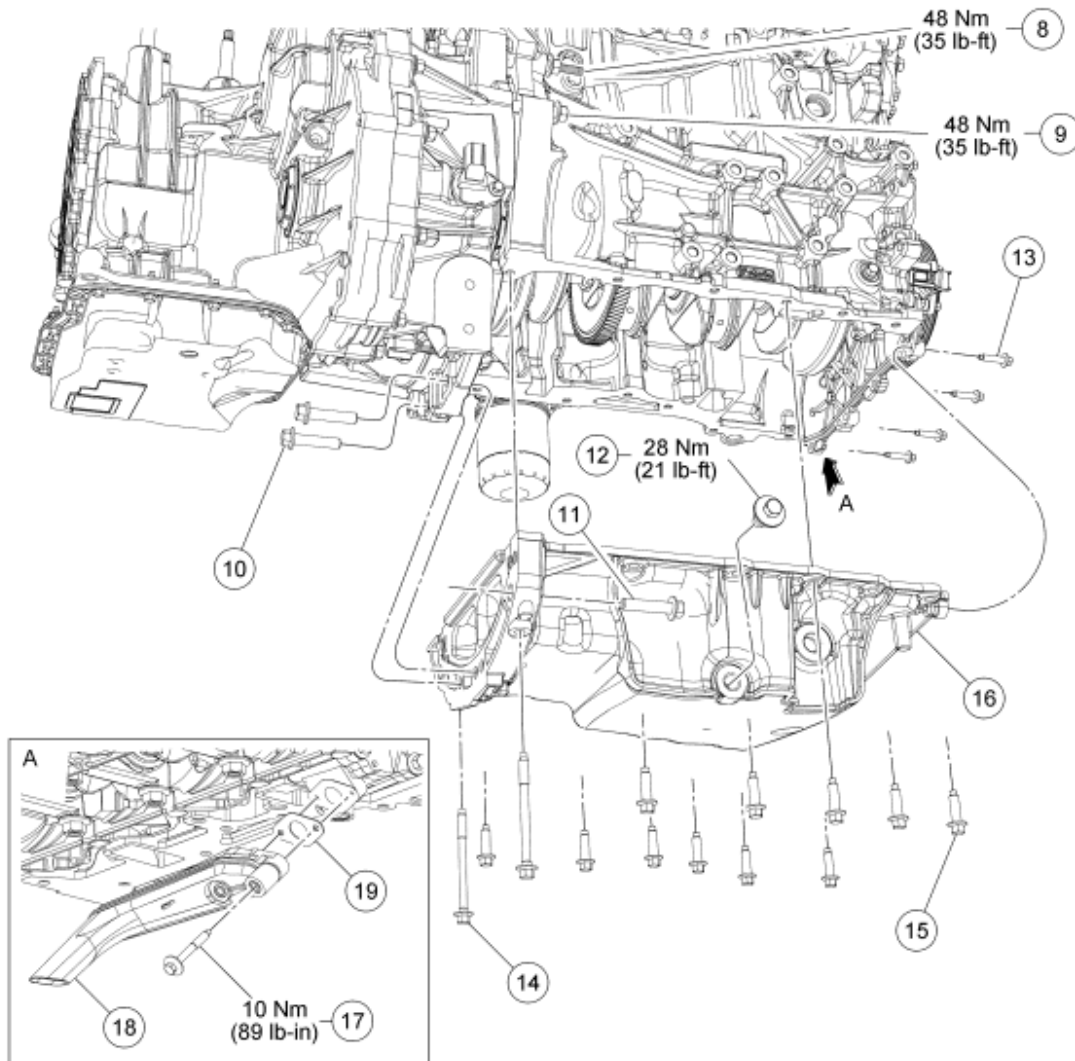

Fig. 178: Exploded View Of Engine Lubrication Components (2 Of 4) (With Torque Specifications)
 Courtesy of FORD MOTOR CO.

Item	Part Number	Description
1	-	Positive battery cable pin-type retainer (2 required)
2	14A464	Transmission wire harness connector
3	W520103	Heated oxygen sensor (HO2S) and catalyst monitor sensor wire connector bracket nut (2 required)
4	14301	HO2S and catalyst monitor sensor wire connector bracket
5	W500124	Upper bellhousing-to-engine stud bolt
6	W500121	Upper bellhousing-to-engine bolt
7	W500125	Front lower bellhousing-to-engine bolts (3 required for manual transmission) (2 required for automatic transmission)

2007 Ford Focus S

2007 ENGINE Engine - 2.0L and 2.3L - Focus



N0058213

Fig. 179: Exploded View Of Engine Lubrication Components (3 Of 4) (With Torque Specifications)
 Courtesy of FORD MOTOR CO.

Item	Part Number	Description
8	W500124	Rear lower engine-to-bellhousing stud bolt
9	W500120	Rear lower engine-to-bellhousing bolt
10	W500121	Bellhousing-to-oil pan bolt (2 required)
11	W500121	Oil pan-to-bellhousing bolt (2 required)
12	6730	Oil pan drain plug
13	W500215	Engine front cover-to-oil pan bolt (4 required)
14	W706284	Oil pan bolt (2 required)
15	W500224	Oil pan bolt (11 required)

2007 Ford Focus S

2007 ENGINE Engine - 2.0L and 2.3L - Focus

16	6675	Oil pan
17	W706282	Oil pump screen and pickup tube bolt (2 required)
18	6622	Oil pump screen and pickup tube
19	6625	Oil pump screen and pickup tube gasket

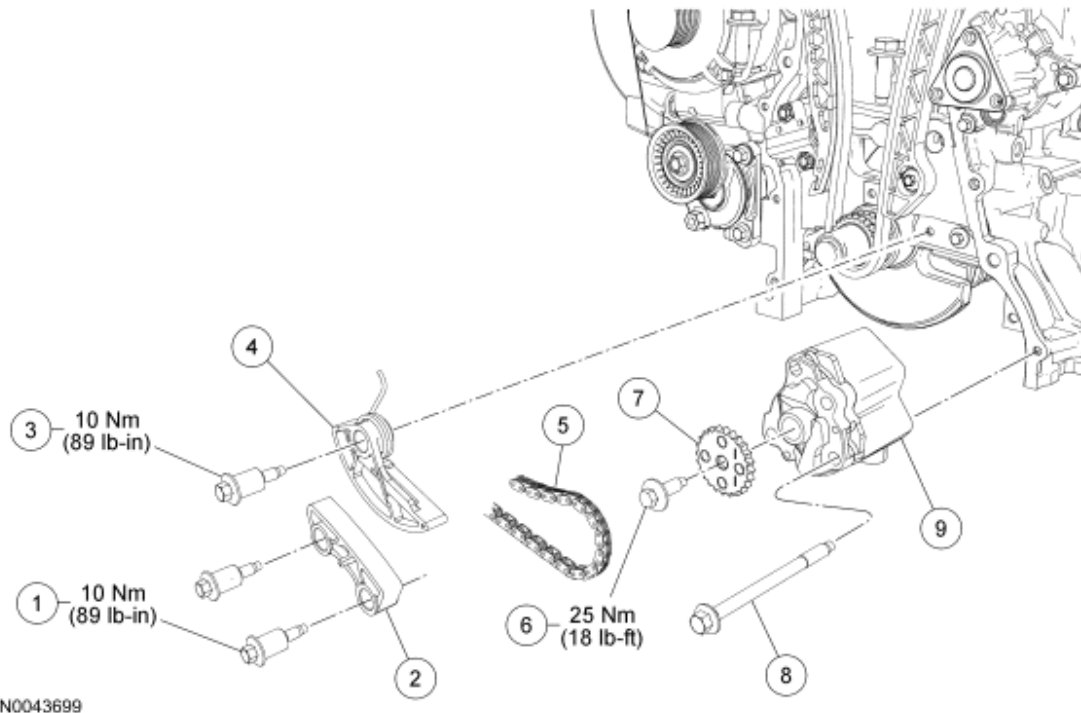

N0043699

Fig. 180: Exploded View Of Engine Lubrication Components (3 Of 3) (With Torque Specifications)
 Courtesy of FORD MOTOR CO.

Item	Part Number	Description
1	W703651	Oil pump drive chain guide shoulder bolt (2 required) (late build)
2	6M256	Oil pump drive chain guide (late build)
3	W703651	Oil pump drive chain tensioner shoulder bolt
4	6C271	Oil pump drive chain tensioner
5	6A895	Oil pump drive chain
6	W704397	Oil pump sprocket bolt
7	6652	Oil pump sprocket
8	W703647	Oil pump bolt (4 required)
9	6600	Oil pump

1. For additional information, refer to the appropriate procedures.

2007 Ford Focus S

2007 ENGINE Engine - 2.0L and 2.3L - Focus

OIL FILTER ADAPTER

Material

Item	Specification
Motorcraft SAE 5W-20 Premium Synthetic Blend Motor Oil XO-5W20-QSP (US); Motorcraft SAE 5W-20 Super Premium Motor Oil CXO-5W20-LSP12 (Canada); or equivalent	WSS-M2C930-A
Thread Sealant with PTFE TA-24	WSK-M2G350-A2

REMOVAL

1. With the vehicle in NEUTRAL, position it on a hoist. For additional information, refer to **JACKING AND LIFTING** article.
2. Disconnect the engine oil pressure (EOP) switch electrical connector.
3. Remove the EOP switch.
4. Remove and discard the oil filter.
5. Remove the 4 bolts and the oil filter adapter.
 - Discard the gasket.

INSTALLATION

1. Using a new gasket, install the oil filter adapter and the 4 bolts.
 - Tighten to 25 Nm (18 lb-ft).

NOTE: Lubricate the engine oil filter gasket with clean engine oil prior to installing the oil filter.

2. Install a new oil filter.
 - Tighten the oil filter 3/4 turn after the oil filter gasket makes contact with the oil filter adapter.

NOTE: Apply thread sealant to the EOP switch threads.

3. Install the EOP switch.
 - Tighten to 15 Nm (11 lb-ft).
4. Connect the EOP switch electrical connector.
5. Top off the engine with clean engine oil.

ENGINE OIL PRESSURE (EOP) SWITCH

Material

--	--

2007 Ford Focus S

2007 ENGINE Engine - 2.0L and 2.3L - Focus

Item	Specification
Thread Sealant with PTFE TA-24	WSK-M2G350-A2

REMOVAL AND INSTALLATION

1. With the vehicle in NEUTRAL, position it on a hoist. For additional information, refer to **JACKING AND LIFTING** article.
2. Disconnect the engine oil pressure (EOP) switch electrical connector.
3. Remove the EOP switch.
 - To install, tighten to 15 Nm (11 lb-ft).

NOTE: Apply thread sealant to the EOP switch threads.

4. To install, reverse the removal procedure.

OIL PAN

Material

Item	Specification
Motorcraft SAE 5W-20 Premium Synthetic Blend Motor Oil XO-5W20-QSP (US); Motorcraft SAE 5W-20 Super Premium Motor Oil CXO-5W20-LSP12 (Canada); or equivalent	WSS-M2C930-A
Motorcraft Metal Surface Cleaner ZC-21	WSE-M5B392-A
Silicone Gasket and Sealant TA-30	WSE-M4G323-A4

REMOVAL

1. With the vehicle in NEUTRAL, position it on a hoist. For additional information, refer to **JACKING AND LIFTING** article.
2. Remove the battery tray. For additional information, refer to **BATTERY, MOUNTING AND CABLES** article.
3. Detach the 2 positive battery cable pin-type retainers and position aside.

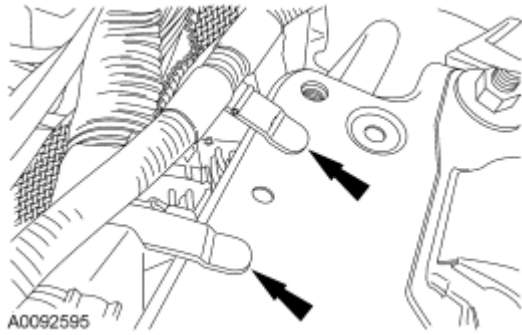

Fig. 181: Locating Positive Battery Cable Pin-Type Retainers
Courtesy of FORD MOTOR CO.

4. Detach the transmission connector wire harness pin-type retainer and position aside.

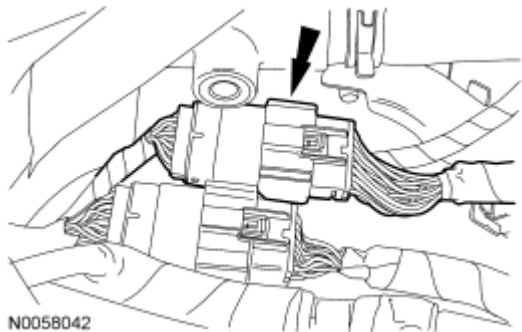

Fig. 182: Locating Transmission Connector Wire Harness Pin-Type Retainer
Courtesy of FORD MOTOR CO.

5. Remove the 2 nuts and position the heated oxygen sensor (HO2S) and catalyst monitor sensor wire connector bracket aside.

CAUTION: To prevent damage to the transmission, do not loosen the transmission-to-engine bolts more than 5 mm (0.19 in).

6. Loosen the upper bellhousing-to-engine bolt and stud bolt 5 mm (0.19 in).
7. Remove the oil level indicator and tube. For additional information, refer to **Oil Level Indicator and Tube**.
8. Loosen the 3 (manual transmission) or 2 (automatic transmission) front lower bellhousing-to-engine bolts 5 mm (0.19 in).
9. Loosen the rear lower engine-to-bellhousing bolt and stud bolt 5 mm (0.19 in).
10. Remove the 2 bellhousing-to-oil pan bolts.
11. Remove the 2 oil pan-to-bellhousing bolts.
12. Slide the transmission rearward 5 mm (0.19 in).
13. Remove the 2 bolts and the accessory drive belt splash shield.

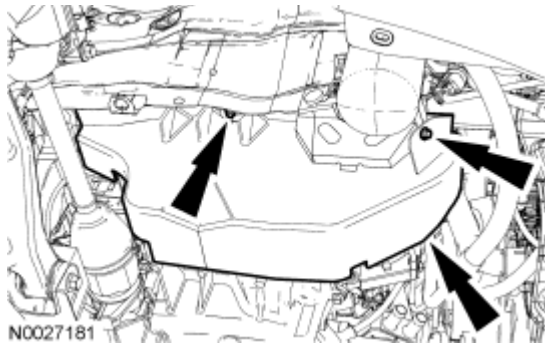

Fig. 183: Locating Accessory Drive Belt Splash Shield And Bolts
Courtesy of FORD MOTOR CO.

14. Drain the engine oil.
 - Install the drain plug.
 - Tighten to 28 Nm (21 lb-ft).
15. Remove the 4 engine front cover-to-oil pan bolts.
16. Remove the 13 bolts and the oil pan.

INSTALLATION

CAUTION: Do not use metal scrapers, wire brushes, power abrasive discs or other abrasive means to clean the sealing surfaces. These tools cause scratches and gouges, which make leak paths. Use a plastic scraping tool to remove traces of sealant.

1. Clean and inspect all mating surfaces.

NOTE: If the oil pan is not secured within 10 minutes of sealant application, the sealant must be removed and the sealing area cleaned with metal surface cleaner. Allow to dry until there is no sign of wetness, or 10 minutes, whichever is longer. Failure to follow this procedure can cause future oil leakage.

2. Apply a 2.5 mm (0.09 in) bead of silicone gasket and sealant to the oil pan-to-engine block and to the oil pan-to-engine front cover mating surface.

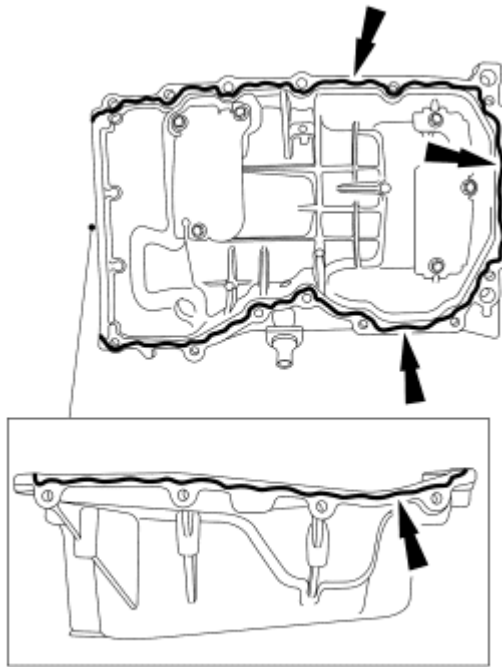

N0059402

Fig. 184: Applying Bead Of Silicone Gasket And Sealant
Courtesy of FORD MOTOR CO.

3. Position the oil pan onto the engine and install the oil pan bolts finger-tight.

CAUTION: The engine front cover-to-oil pan bolts must be tightened first to align the front surface of the oil pan flush with the front surface of the engine block.

4. Install the 4 engine front cover-to-oil pan bolts.
 - Tighten to 10 Nm (89 lb-in).

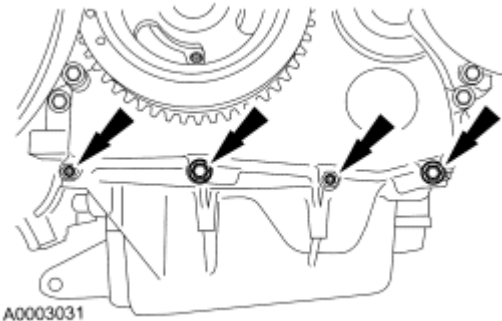

A0003031

Fig. 185: Locating Bolts
Courtesy of FORD MOTOR CO.

5. Tighten the oil pan bolts in the sequence shown.

- Tighten to 25 Nm (18 lb-ft).

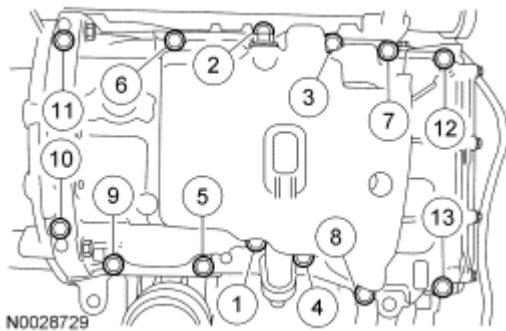

Fig. 186: Identifying Tightening Sequence Of Oil Pan Bolts
Courtesy of FORD MOTOR CO.

6. Install the accessory drive belt splash shield and the 2 bolts.
 - Tighten to 9 Nm (80 lb-in).

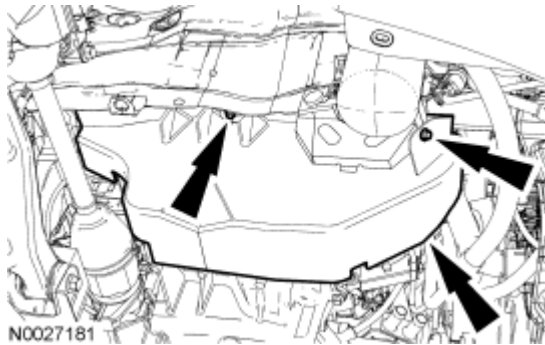

Fig. 187: Locating Accessory Drive Belt Splash Shield And Bolts
Courtesy of FORD MOTOR CO.

7. Alternate tightening the 1 front bellhousing-to-engine and 1 rear engine-to-bellhousing lower bolts to slide the transmission and engine together.
 - Tighten to 48 Nm (35 lb-ft).
8. Tighten the remaining 1 (automatic transmission) or 2 (manual transmission) lower front bellhousing-to-engine bolt(s) and the remaining rear engine-to-bellhousing stud bolt.
 - Tighten to 48 Nm (35 lb-ft).
9. Install the 2 bellhousing-to-oil pan bolt.
 - Tighten to 48 Nm (35 lb-ft).
10. Install the 2 oil pan-to-bellhousing bolts.
 - Tighten to 48 Nm (35 lb-ft).
11. Install the oil level indicator and tube. For additional information, refer to **Oil Level Indicator and Tube**.
12. Tighten the top bellhousing-to-engine bolt and stud bolt.
 - Tighten to 48 Nm (35 lb-ft).
13. Position the HO2S and catalyst monitor sensor wire connector bracket and install the 2 nuts.

- Tighten to 25 Nm (18 lb-ft).

14. Position and attach the transmission connector wire harness pin-type retainer.

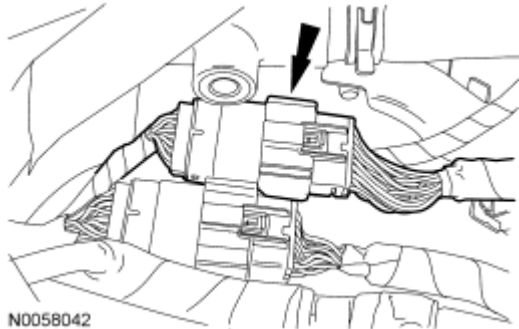

Fig. 188: Locating Transmission Connector Wire Harness Pin-Type Retainer
Courtesy of FORD MOTOR CO.

15. Position and attach the 2 positive battery cable pin-type retainers.

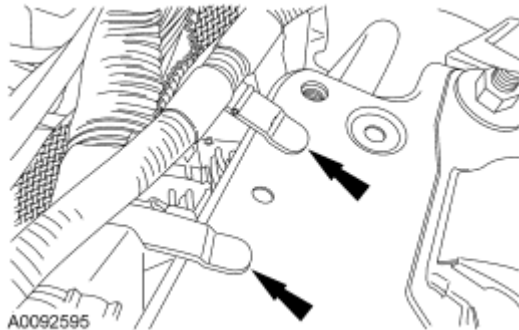

Fig. 189: Locating Positive Battery Cable Pin-Type Retainers
Courtesy of FORD MOTOR CO.

16. Install the battery tray. For additional information, refer to **BATTERY, MOUNTING AND CABLES** article.
17. Fill the engine with clean engine oil.

OIL PUMP SCREEN AND PICKUP TUBE

REMOVAL

1. With the vehicle in NEUTRAL, position it on a hoist. For additional information, refer to **JACKING AND LIFTING** article.
2. Remove the oil pan. For additional information, refer to **Oil Pan**.
3. Remove the 2 bolts and the oil pump screen and pickup tube.
 - Discard the gasket.

INSTALLATION

1. Clean and inspect all mating surfaces.
2. Using a new gasket, install the oil pump screen and pickup tube and the 2 bolts.
 - Tighten to 10 Nm (89 lb-in).
3. Install the oil pan. For additional information, refer to **Oil Pan**.

OIL PUMP

Material

Item	Specification
Motorcraft SAE 5W-20 Premium Synthetic Blend Motor Oil XO-5W20-QSP (US); Motorcraft SAE 5W-20 Super Premium Motor Oil CXO-5W20-LSP12 (Canada); or equivalent	WSS-M2C930-A
Silicone Gasket and Sealant TA-30	WSE-M4G323-A4
Motorcraft Metal Surface Cleaner ZC-21	WSE-M5B392-A

REMOVAL

NOTE: Early build engines are equipped with an oil pump drive chain guide. Late build engines do not have an oil pump drive chain guide. Also, late build engines use an updated design for the oil pump drive chain and tensioner. Therefore, the oil pump drive components are not interchangeable between early build and late build engines.

All vehicles

1. With the engine in NEUTRAL, position it on a hoist. For additional information, refer to **JACKING AND LIFTING** article.
2. Remove the engine front cover. For additional information, refer to **Engine Front Cover**.
3. Remove the oil level indicator and tube. For additional information, refer to **Oil Level Indicator and Tube**.
4. Drain the engine oil, then install the drain plug.
 - To install, tighten to 28 Nm (21 lb-ft).
5. Remove the 4 oil pan-to-bellhousing bolts.
6. Remove the 13 bolts and the oil pan.

NOTE: Discard the gasket and clean and inspect the gasket mating surfaces.

7. Remove the 2 bolts and the oil pump screen and pickup tube.
 - To install, tighten to 10 Nm (89 lb-in).

Early build vehicles

8. Remove the oil pump drive chain tensioner and guide.
 1. Release the tension on the tensioner spring.
 2. Remove the 2 shoulder bolts and the tensioner.
 3. Remove the 2 shoulder bolts and the guide.

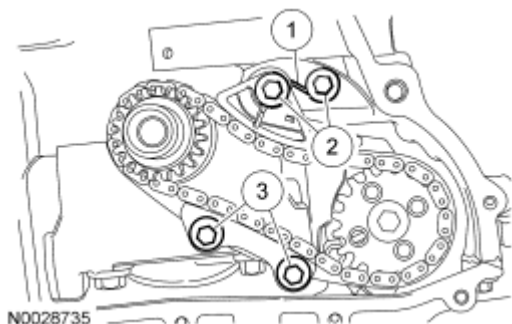

Fig. 190: Locating Oil Pump Bolts
 Courtesy of FORD MOTOR CO.

Late build vehicles

9. Remove the oil pump drive chain tensioner.
 - Release the tension on the tensioner spring.
 - Remove the tensioner and the 2 shoulder bolts.

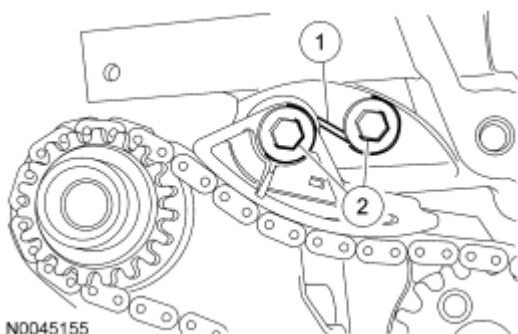

Fig. 191: Locating Shoulder Bolts & Tensioner
 Courtesy of FORD MOTOR CO.

All vehicles

10. Remove the chain from the oil pump sprocket.
11. Remove the bolt and oil pump sprocket.
12. Remove the 4 bolts and the oil pump.

INSTALLATION

All vehicles

NOTE: Clean the oil pump and cylinder block mating surfaces with metal surface cleaner.

1. Install the oil pump assembly. Tighten the 4 bolts in the sequence shown in 2 stages:
 - Stage 1: Tighten to 10 Nm (89 lb-in).
 - Stage 2: Tighten to 20 Nm (15 lb-ft).

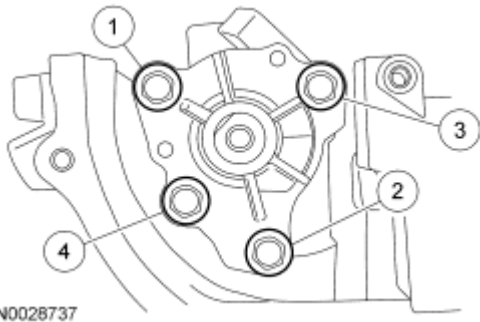

Fig. 192: Identifying Oil Pump Bolts Tightening Sequence
Courtesy of FORD MOTOR CO.

2. Install the oil pump sprocket and bolt.
 - Tighten to 25 Nm (18 lb-ft).
3. Install the chain onto the oil pump sprocket.

Late build vehicles

4. Install the oil pump drive chain tensioner shoulder bolt.
 - Tighten to 10 Nm (89 lb-in).

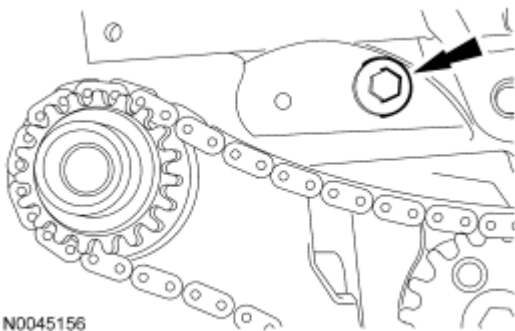

Fig. 193: Locating Oil Pump Chain Drive Tensioner Shoulder Bolt
Courtesy of FORD MOTOR CO.

Early build vehicles

5. Install the oil pump drive chain guide and the shoulder bolts.
 - Tighten to 10 Nm (89 lb-in).

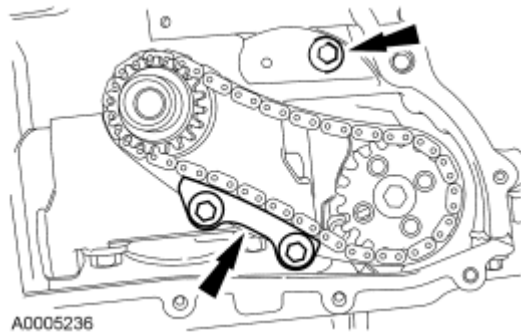

Fig. 194: Installing Oil Pump Drive Chain Guide And Shoulder Bolts
Courtesy of FORD MOTOR CO.

All vehicles

6. Install the oil pump chain tensioner and bolt. Hook the tensioner spring around the shoulder bolt.
 - Tighten to 10 Nm (89 lb-in).

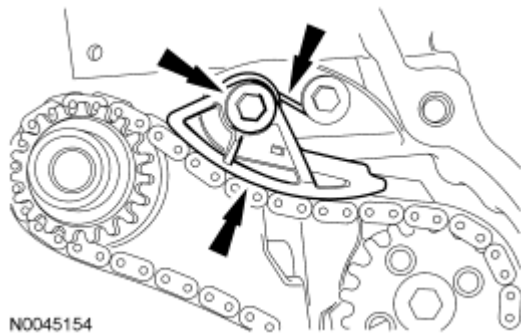

Fig. 195: Locating Oil Pump Chain Tensioner
Courtesy of FORD MOTOR CO.

7. Install the oil pump screen and pickup tube and the 2 bolts.
 - Tighten to 10 Nm (89 lb-in).

CAUTION: Do not use metal scrapers, wire brushes, power abrasive discs or other abrasive means to clean the sealing surfaces. These tools cause scratches and gouges, which make leak paths. Use a plastic scraping tool to remove traces to sealant.

8. Clean all mating surfaces with metal surface cleaner.

NOTE: If the oil pan is not secured within 10 minutes of sealant application, the sealant must be removed and the sealing area cleaned with metal surface

cleaner. Allow to dry until there is no sign of wetness, or 10 minutes, whichever is longer. Failure to follow this procedure can cause future oil leakage.

9. Apply a 2.5 mm (0.09 in) bead of sealant gasket and sealant to the oil pan.
 - Position the oil pan onto the engine and install the 2 rear oil pan bolts finger-tight.

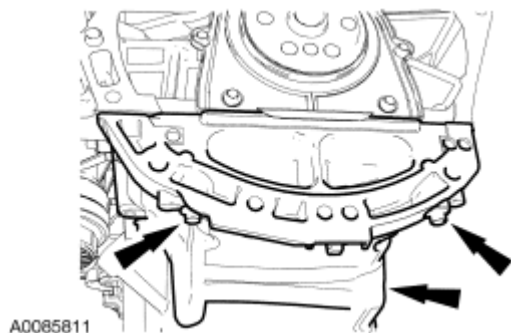

Fig. 196: Identifying Rear Oil Pan Bolts
Courtesy of FORD MOTOR CO.

10. Using a suitable straight edge, align the front surface of the oil pan flush with the front surface of the engine block.

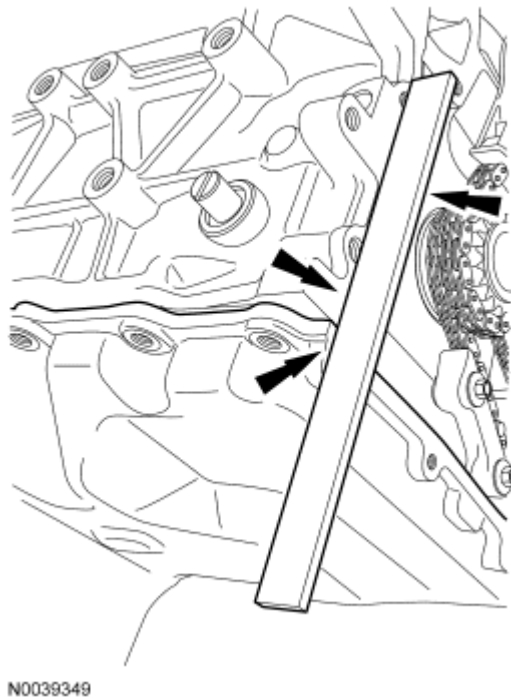

Fig. 197: Aligning Front Surface Of The Oil Pan
Courtesy of FORD MOTOR CO.

11. Install the remaining oil pan bolts.
 - Tighten in the sequence shown to 25 Nm (18 lb-ft).

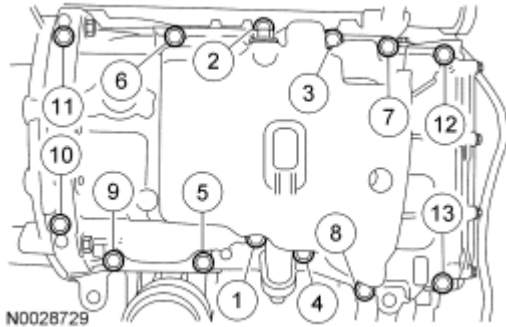

Fig. 198: Identifying Tightening Sequence Of Oil Pan Bolts
 Courtesy of FORD MOTOR CO.

12. Install the 4 oil pan-to-bellhousing bolts.
 - Tighten to 48 Nm (35 lb-ft).
13. Install the oil level indicator and tube. For additional information, refer to **Oil Level Indicator and Tube**.
14. Install the engine front cover. For additional information, refer to **Engine Front Cover**.
15. Fill the engine with clean engine oil.

OIL LEVEL INDICATOR AND TUBE

Material

Item	Specification
Motorcraft SAE 5W-20 Premium Synthetic Blend Motor Oil XO-5W20-QSP (US); Motorcraft SAE 5W-20 Super Premium Motor Oil CXO-5W20-LSP12 (Canada); or equivalent	WSS-M2C930-A

2007 Ford Focus S

2007 ENGINE Engine - 2.0L and 2.3L - Focus

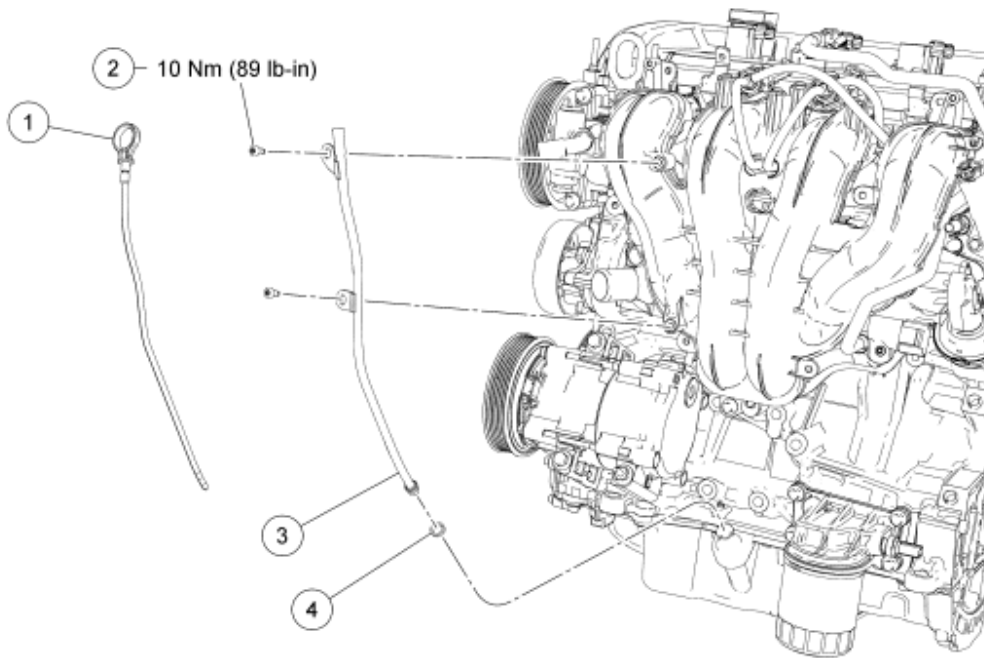

N0033417

Fig. 199: Identifying Oil Level Indicator And Tube (With Torque Specifications)
 Courtesy of FORD MOTOR CO.

Item	Part Number	Description
1	6750	Oil level indicator
2	W500211	Oil level indicator tube bolt
3	6754	Oil level indicator tube
4	6754-B	O-ring seal

REMOVAL AND INSTALLATION

NOTE: 2.3L engine shown, 2.0L engine similar with only one retaining bolt.

1. Remove the oil level indicator and position aside.
2. Remove the 2 bolts for 2.3L engines or the 1 bolt for 2.0L engines and the oil level indicator tube.
 - To install, tighten to 10 Nm (89 lb-in).
3. To install, reverse the removal procedure.

ENGINE MOUNT

Special Tools

Illustration	Tool Name	Tool Number

2007 Ford Focus S

2007 ENGINE Engine - 2.0L and 2.3L - Focus

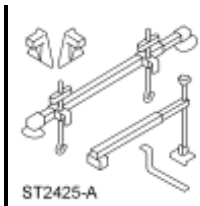

3-Bar Engine Support Kit

303-F072

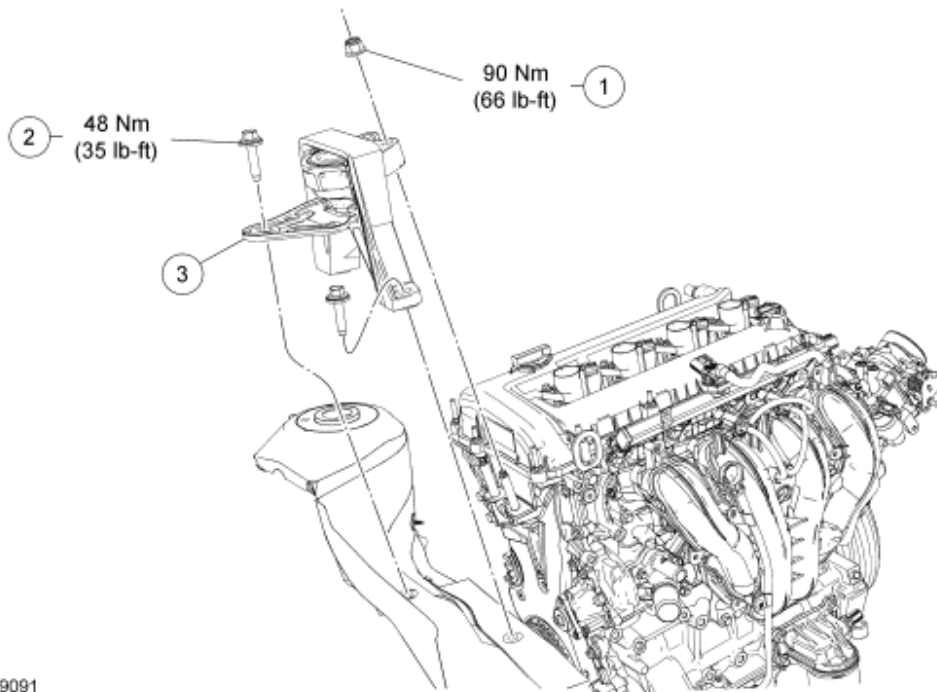

N0049091

Fig. 200: Identifying Engine Mount Components (With Torque Specifications)
Courtesy of FORD MOTOR CO.

Item	Part Number	Description
1	W520214	Engine mount bracket nut (2 required)
2	W709417	Engine mount bracket bolt (3 required)
3	6F012	Engine mount

REMOVAL AND INSTALLATION

1. Remove the expansion tank bolt.
 - To install, tighten to 10 Nm (89 lb-in).

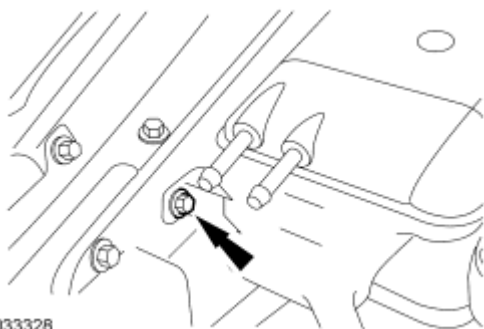

Fig. 201: Locating Expansion Tank Bolt
Courtesy of FORD MOTOR CO.

2. Lift the coolant expansion tank out of the retainer and position it aside.



Fig. 202: Removing Coolant Expansion Tank
Courtesy of FORD MOTOR CO.

3. Install the special tool.

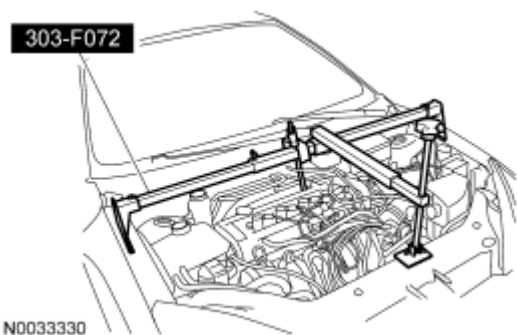

Fig. 203: Identifying Special Tool (303-F072)
Courtesy of FORD MOTOR CO.

4. Remove the 2 engine mount nuts.
 - To install, tighten to 90 Nm (66 lb-ft).
5. Remove the 3 bolts and the engine mount.
 - To install, tighten to 48 Nm (35 lb-ft).

2007 Ford Focus S







2007 ENGINE Engine - 2.0L and 2.3L - Focus

6. To install, reverse the removal procedure.

REMOVAL





ENGINE

Special Tools

Illustration	Tool Name	Tool Number
 ST1341-A	Heavy Duty Floor Crane	014-00071 or equivalent
 ST1602-A	Spreader Bar	303-D089 (D93P-6001-A3) or equivalent
 ST1682-A	Powertrain Lift with Tilting Plate	014-00765 or equivalent
 ST2743A	Universal Adapter Brackets	014-0001
 ST1636-A	Torque Converter Holding Tool	307-346 (T97T-7902-A)
 ST2793-A	Lifting Bracket, Engine	303-050 (T70P-6000)
	Tie-Rod End Remover	211-001 (TOOL-3290-D) or equivalent

2007 Ford Focus S

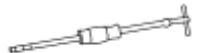
2007 ENGINE Engine - 2.0L and 2.3L - Focus

 ST1522-A		
 ST1523-A	Transaxle Plugs	308-152 (T88C-7025-AH)
 ST1185-A	Slide Hammer	100-001 (T50T-100-A)
 ST1582-A	Front Drive Halfshaft Remover	205-241 (T86P-3514-A)

All vehicles

1. With the vehicle in NEUTRAL, position it on a hoist. For additional information, refer to **JACKING AND LIFTING** article.
2. Release the fuel system pressure. For additional information, refer to **FUEL SYSTEM - GENERAL INFORMATION** article.
3. Remove the accessory drive belt. For additional information, refer to **ACCESSORY DRIVE** article.
4. Remove the battery tray. For additional information, refer to **BATTERY, MOUNTING AND CABLES** article.
5. Remove the power steering pump. For additional information, refer to **POWER STEERING** article.

Vehicles equipped with air conditioning

6. Recover the A/C system. For additional information, refer to **CLIMATE CONTROL SYSTEM - GENERAL INFORMATION AND DIAGNOSTICS** article.

All vehicles

7. Drain the engine cooling system. For additional information, refer to **ENGINE COOLING** article.
8. Drain the engine oil.
 - Install the drain plug and tighten to 28 Nm (21 lb-ft).

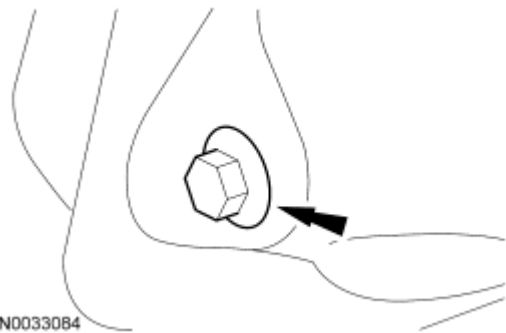

Fig. 204: Locating Drain Plug
Courtesy of FORD MOTOR CO.

9. Remove the 2 nuts and disconnect the catalytic converter from the muffler assembly.
 - Remove and discard the gasket.

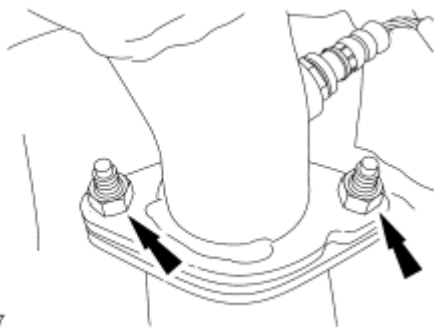

Fig. 205: Locating Catalytic Converter Nuts
Courtesy of FORD MOTOR CO.

10. Remove the 4 bolts and the catalytic converter support bracket.

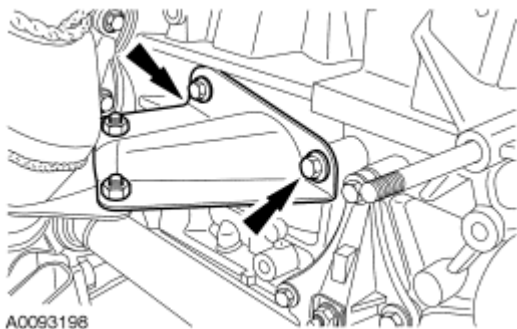

Fig. 206: Locating Catalytic Converter Support Bracket And Bolts
Courtesy of FORD MOTOR CO.

NOTE: All 2.3L engines and some 2.0L engines are equipped with a heat shield that must be positioned aside to access the catalytic converter-to-engine nuts.

11. If equipped, remove the 4 heat shield bolts and position the heat shield aside.

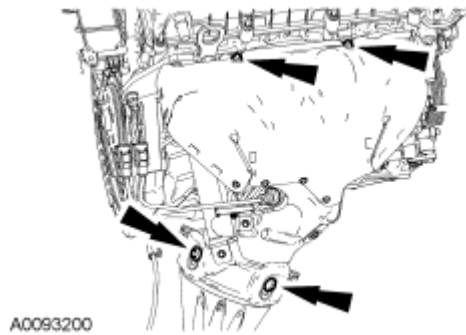

Fig. 207: Locating Heat Shield Bolts
Courtesy of FORD MOTOR CO.

12. Disconnect the exhaust sensor electrical connectors.

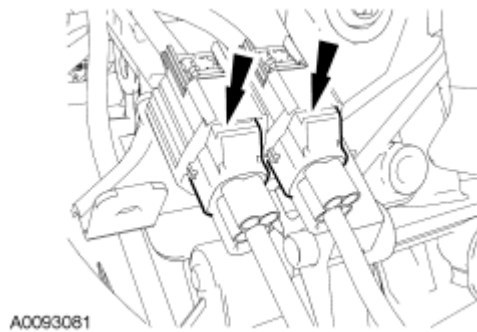

Fig. 208: Locating Electrical Connectors And Wiring Retainers
Courtesy of FORD MOTOR CO.

13. If equipped, disconnect the upper exhaust sensor electrical connector and retainer.

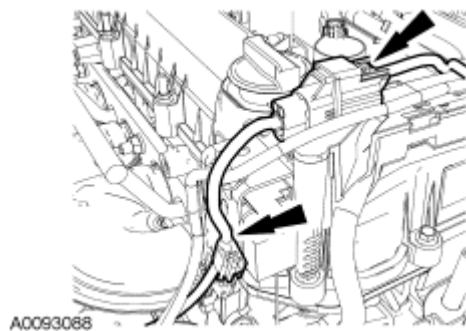

Fig. 209: Locating Electrical Connector And Wiring Retainer
Courtesy of FORD MOTOR CO.

14. If equipped, disconnect the secondary air injection (AIR) hose.



Fig. 210: Locating Secondary Air Injection (AIR) Hose
Courtesy of FORD MOTOR CO.

15. Remove and discard the 7 catalytic converter-to-engine nuts.
 - Position aside the catalytic converter and support with mechanic's wire.
 - Remove and discard the catalytic converter gasket.

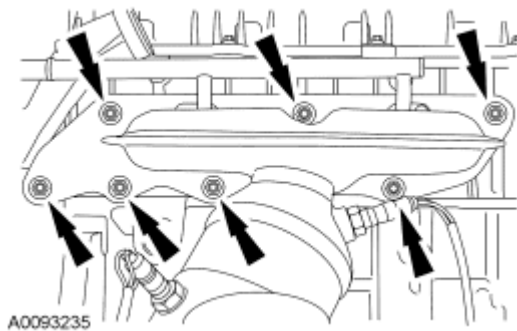

Fig. 211: Locating Catalytic Converter-To-Engine Nuts
Courtesy of FORD MOTOR CO.

16. Loosen the clamp and disconnect the vent tube from the air cleaner outlet pipe.

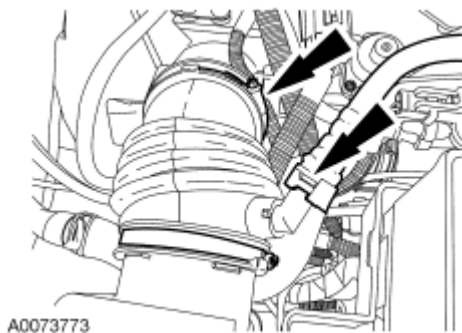

Fig. 212: Locating Vent Tube And Clamp
Courtesy of FORD MOTOR CO.

17. Remove the 2 bolts and detach the air intake resonator from the grommets.
 - Remove the air intake resonator and outlet pipe.

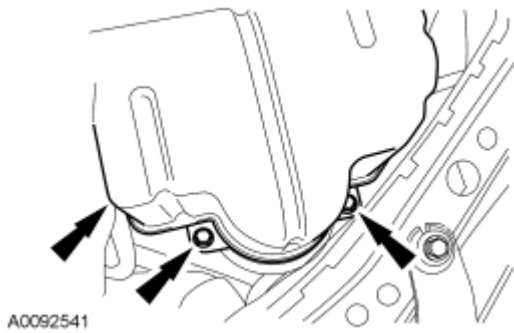

Fig. 213: Locating Air Intake Resonator Bolts And Air Intake Resonator
 Courtesy of FORD MOTOR CO.

18. Remove the accelerator control snow shield.
 - Detach the evaporative emissions (EVAP) hose pin-type retainer.
 - Remove the screw, the pin-type retainer and the snow shield.

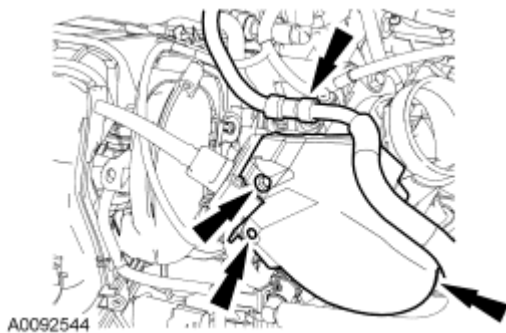

Fig. 214: Locating Accelerator Snow Shield, Screw And Pin-Type Retainers
 Courtesy of FORD MOTOR CO.

19. Disconnect the accelerator cable and speed control cable (if equipped).
 1. Disconnect the accelerator and speed control cable (if equipped) from the throttle body.
 2. Remove the 3 bolts and position the accelerator control cables and bracket aside.

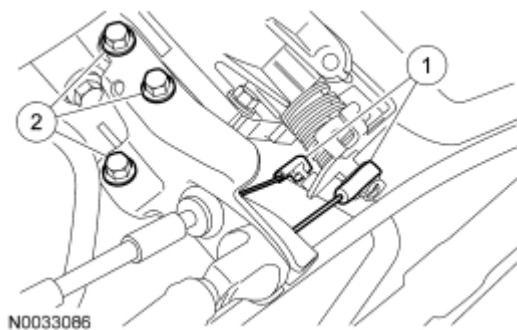
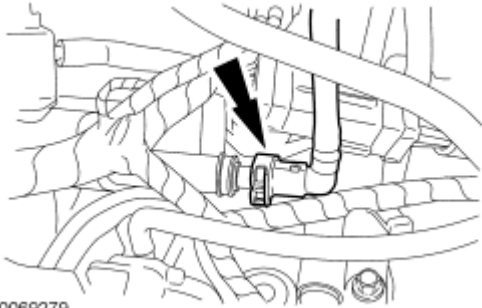

Fig. 215: Identifying Accelerator & Speed Control Cable And Bolts
 Courtesy of FORD MOTOR CO.

20. Disconnect the fuel tube quick connect coupling from the fuel rail and position the fuel tube aside. For additional information, refer to **FUEL SYSTEM - GENERAL INFORMATION** article.



A0069279

Fig. 216: Locating Fuel Tube Quick Connect Coupling
Courtesy of FORD MOTOR CO.

21. Disconnect the evaporative emissions tube. For additional information, refer to **FUEL SYSTEM - GENERAL INFORMATION** article.

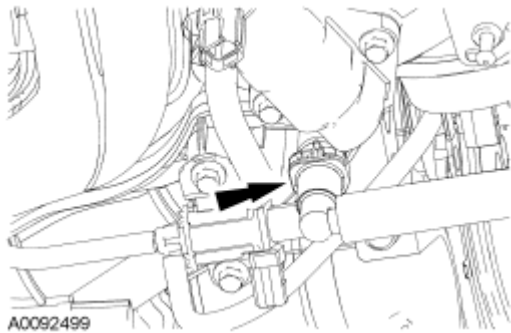

A0092499

Fig. 217: Locating Evaporative Emissions Tube
Courtesy of FORD MOTOR CO.

22. If equipped, disconnect the AIR hose.

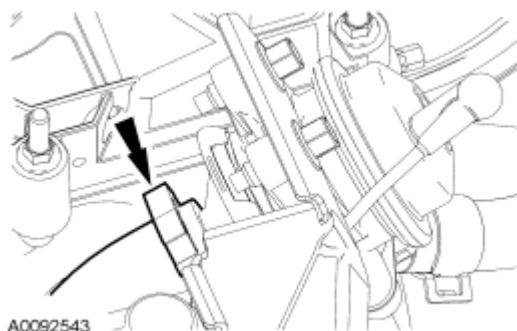

A0092543

Fig. 218: Locating Air Hose
Courtesy of FORD MOTOR CO.

23. If equipped, disconnect the AIR vacuum regulator electrical connector.

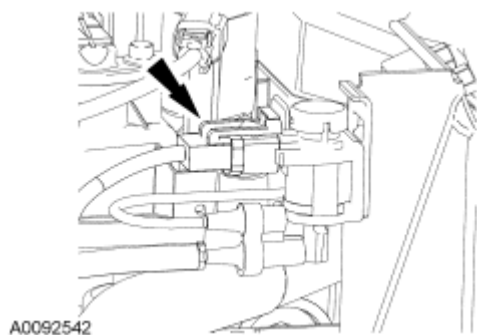

Fig. 219: Locating Air Vacuum Regulator Electrical Connector
Courtesy of FORD MOTOR CO.

24. Disconnect the power brake booster vacuum tube.
 - Depress the quick connect locking ring.
 - Pull the vacuum tube out of the quick connect fitting.

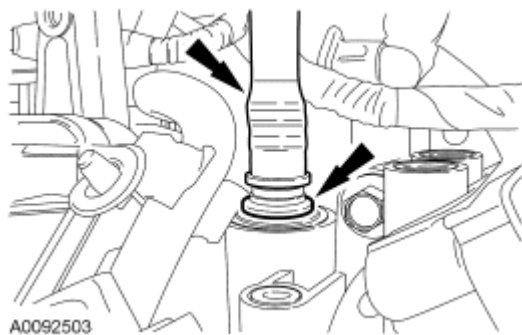

Fig. 220: Locating Power Brake Booster Vacuum Tube And Quick Release Locking Ring
Courtesy of FORD MOTOR CO.

25. Disconnect the exhaust gas recirculation (EGR) valve electrical connector.

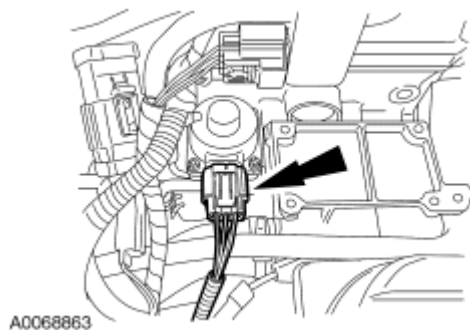
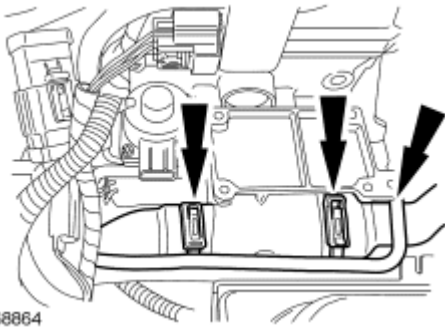

Fig. 221: Locating Exhaust Gas Recirculation Valve Electrical Connector
Courtesy of FORD MOTOR CO.

26. Disconnect the upper radiator hose, the heater hose and the coolant vent hose from the coolant bypass.



A0068864

Fig. 222: Locating Upper Radiator Hose, Heater Hose And Coolant Vent Hose
Courtesy of FORD MOTOR CO.

27. Remove the bolt and ground eyelet.

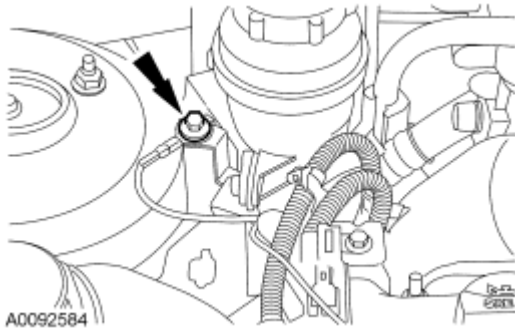

A0092584

Fig. 223: Locating Ground Eyelet Bolt
Courtesy of FORD MOTOR CO.

28. Disconnect the fuel charging wiring harness electrical connector and harness retainer.

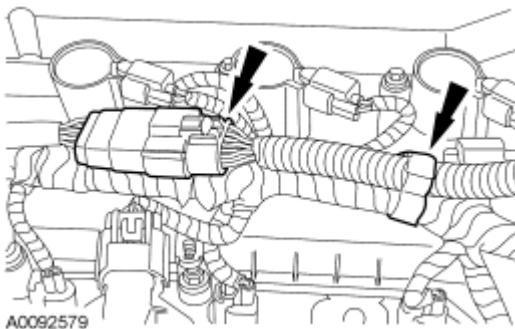

A0092579

Fig. 224: Locating Fuel Charging Wiring Harness Electrical Connector And Harness Retainer
Courtesy of FORD MOTOR CO.

29. Disconnect the fuel charging wiring harness electrical connector.

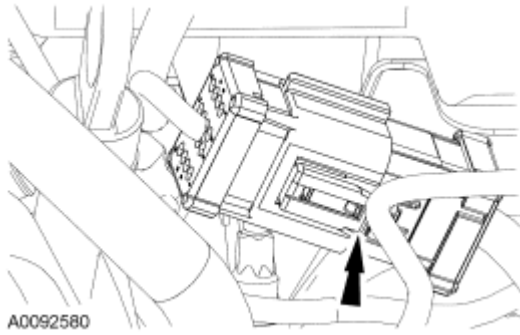

Fig. 225: Locating Fuel Charging Wiring Harness Electrical Connector
Courtesy of FORD MOTOR CO.

30. Disconnect the power distribution wiring harness electrical connector.

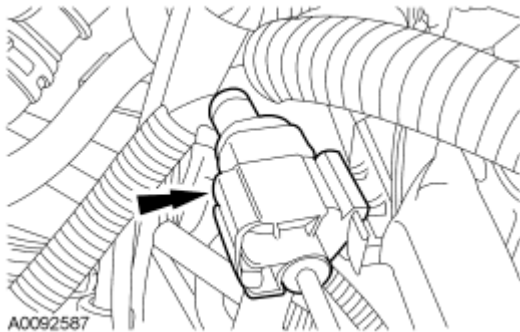

Fig. 226: Locating Power Distribution Wiring Harness Electrical Connector
Courtesy of FORD MOTOR CO.

31. Detach the wiring harness retainers.

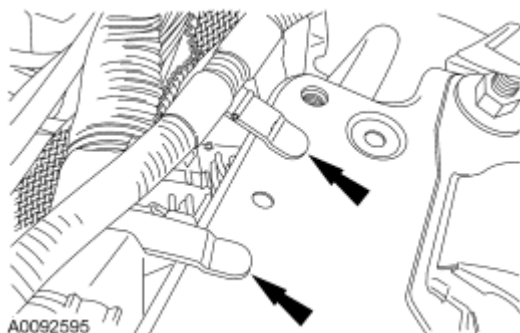

Fig. 227: Locating Positive Battery Cable Pin-Type Retainers
Courtesy of FORD MOTOR CO.

32. Remove the nut and the power distribution wiring harness eyelet.

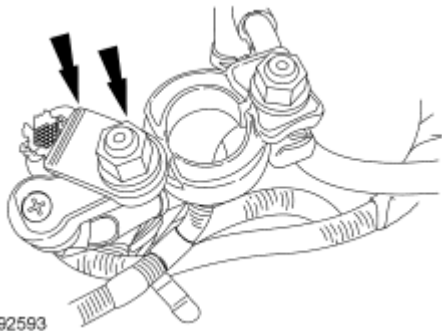

Fig. 228: Locating Power Distribution Wiring Harness Eyelet And Nut
Courtesy of FORD MOTOR CO.

33. Disconnect the 3 main engine wiring harness electrical connectors and detach the connectors from the bracket.

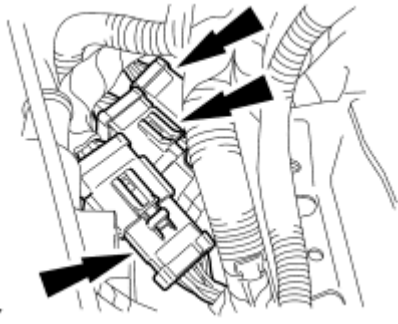

Fig. 229: Locating Main Engine Wiring Harness Electrical Connectors
Courtesy of FORD MOTOR CO.

Vehicles equipped with a manual transmission

NOTE: Press the locking tab.

34. Detach the gearshift cables from the transaxle.
 1. Detach the shifter cable from the shift mass.
 2. Detach the selector cable from the selector lever.

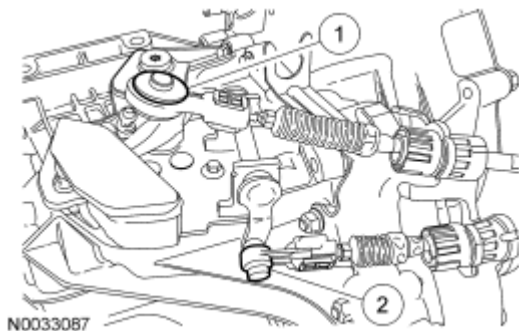

Fig. 230: Identifying Shifter Cable And Selector Cable
Courtesy of FORD MOTOR CO.

35. Detach the gearshift cables from the bracket.
1. Detach the shifter cable from the retaining bracket, turning the abutment sleeves counterclockwise.
 2. Detach the selector cable from the retaining bracket, turning the abutment sleeves counterclockwise.

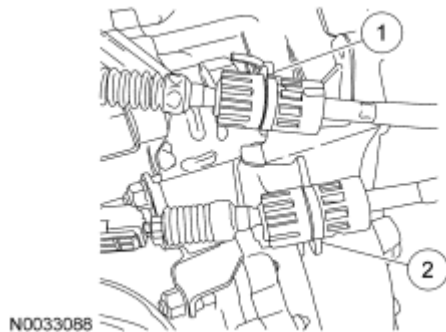

Fig. 231: Identifying Shifter And Selector Cable
Courtesy of FORD MOTOR CO.

WARNING: Escaping brake fluid. Do not allow brake fluid to come into contact with the skin or the eyes. If brake fluid does come into contact with the skin or eyes, rinse the affected areas with water immediately. Failure to follow these instructions may result in personal injury.

CAUTION: If brake fluid is spilled on the paintwork, the affected area must be immediately washed down with cold water.

36. Remove the clutch slave cylinder supply tube.
- Remove the clip.
 - Remove the supply tube and secure it to one side using cable ties.

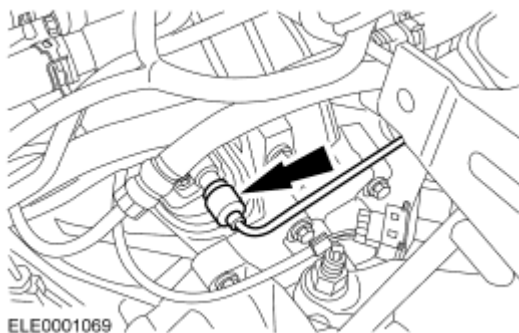

Fig. 232: Locating Clutch Slave Cylinder Supply Tube
Courtesy of FORD MOTOR CO.

37. Disconnect the reversing lamp switch electrical connector.

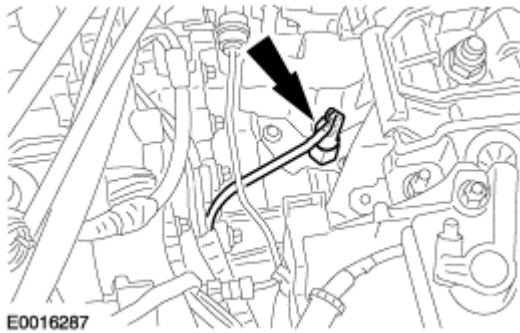

Fig. 233: Locating Reversing Lamp Switch Electrical Connector
Courtesy of FORD MOTOR CO.

Vehicles equipped with a 2.0L engine and automatic transmission

38. Disconnect the transmission shifter cable and position it aside.

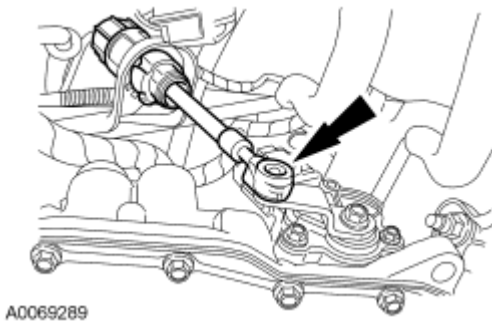

Fig. 234: Locating Transmission Shifter Cable
Courtesy of FORD MOTOR CO.

39. Disconnect the transmission cooler hoses.

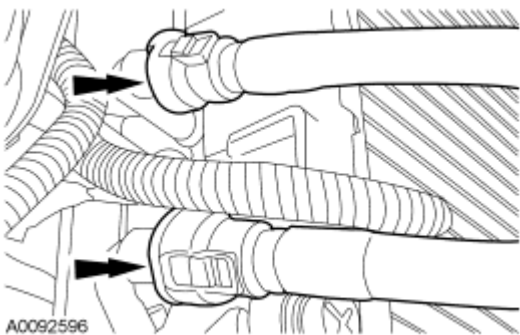
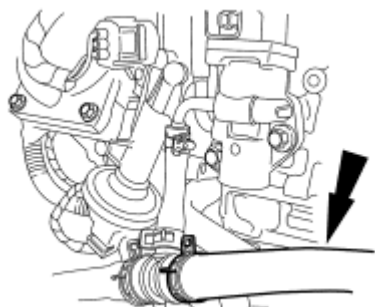

Fig. 235: Locating Transmission Cooler Hoses
Courtesy of FORD MOTOR CO.

All vehicles

40. Disconnect the heater hose from the "T" fitting and position it aside.



A0069285

Fig. 236: Locating Heater Hose
Courtesy of FORD MOTOR CO.

41. Disconnect the coolant hoses from the coolant expansion tank.

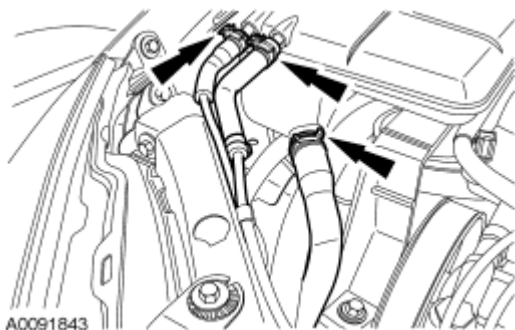

A0091843

Fig. 237: Locating Coolant Hoses
Courtesy of FORD MOTOR CO.

42. Remove the coolant expansion tank bolt.

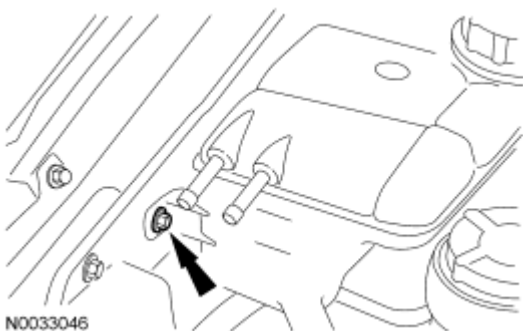

N0033046

Fig. 238: Locating Coolant Expansion Tank Bolt
Courtesy of FORD MOTOR CO.

43. Remove the coolant expansion tank.
 - Lift the coolant expansion tank out of the retainer.

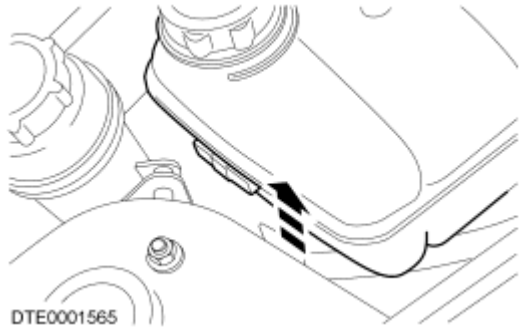

Fig. 239: Removing Coolant Expansion Tank
Courtesy of FORD MOTOR CO.

44. Disconnect the cooling fan electrical connectors.

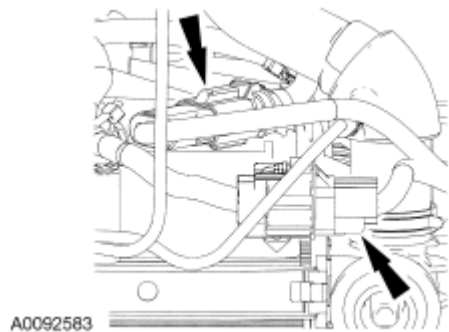

Fig. 240: Locating Cooling Fan Electrical Connectors
Courtesy of FORD MOTOR CO.

45. Release the top cooling fan retaining clips, lift up and remove the cooling fan.

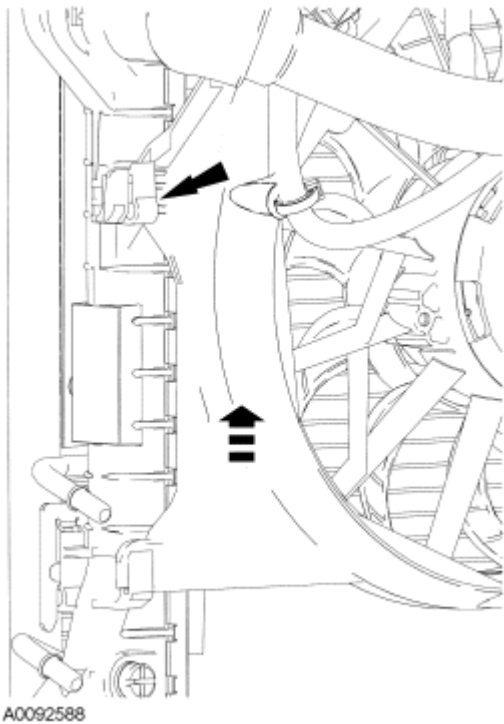

Fig. 241: Identifying Top Cooling Fan Retaining Clips Removing Cooling Fan
Courtesy of FORD MOTOR CO.

46. Disconnect the lower radiator hose.

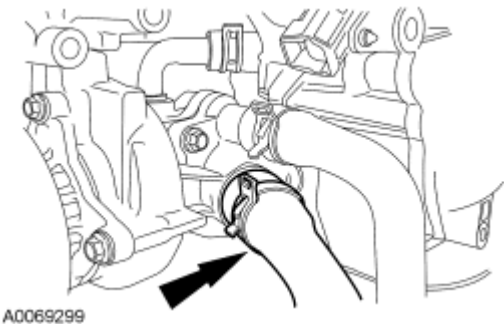

Fig. 242: Locating Lower Radiator Hose
Courtesy of FORD MOTOR CO.

47. Remove the bolt and the ground cable.

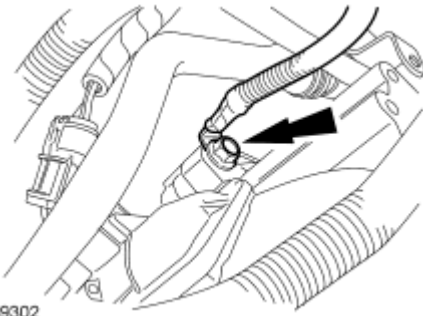

Fig. 243: Locating Ground Cable Bolt
Courtesy of FORD MOTOR CO.

48. Remove the generator cooling pipe.

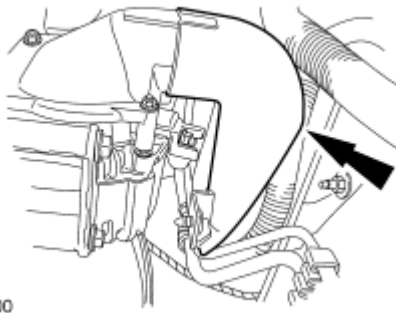

Fig. 244: Locating Generator Cooling Pipe
Courtesy of FORD MOTOR CO.

49. Disconnect the starter motor electrical terminals.

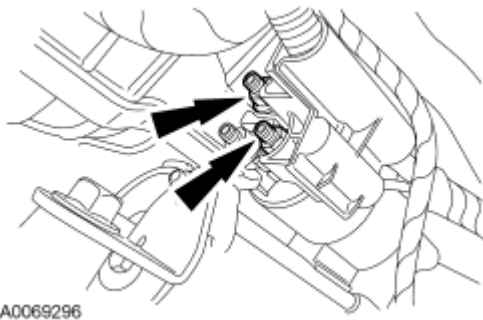

Fig. 245: Locating Starter Motor Electrical Terminals
Courtesy of FORD MOTOR CO.

50. Remove the 2 nuts and detach the PSP tube brackets from the stud bolts.

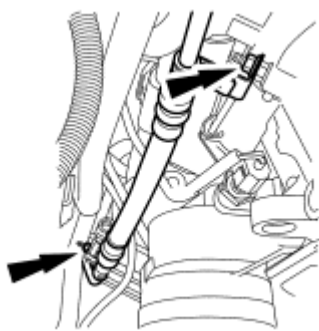

Fig. 246: Locating PSP Tube Bracket Nuts
Courtesy of FORD MOTOR CO.

Vehicles equipped with air conditioning

51. Disconnect the A/C compressor electrical connector.



Fig. 247: Locating A/C Compressor Electrical Connector
Courtesy of FORD MOTOR CO.

52. Remove the 3 A/C compressor bolts.

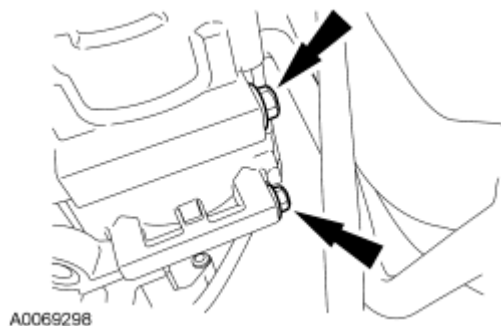
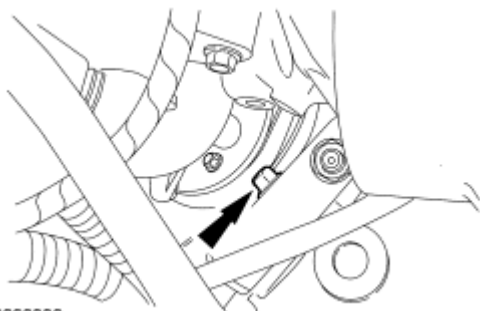

Fig. 248: Locating A/C Compressor Bolts
Courtesy of FORD MOTOR CO.

53. Loosen the bolt and remove the A/C compressor.
 - Lower the A/C compressor to access the manifold bolt.

- Discard the O-ring seals.



A0093330

Fig. 249: Locating A/C Compressor Bolt
Courtesy of FORD MOTOR CO.

All vehicles

54. Detach the LH brake hose from the support bracket.

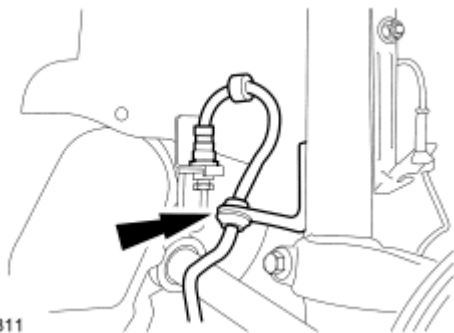

E0010311

Fig. 250: Locating LH Brake Hose
Courtesy of FORD MOTOR CO.

55. Detach the LH caliper.
 1. Remove the bolt covers.
 2. Remove the 2 bolts.

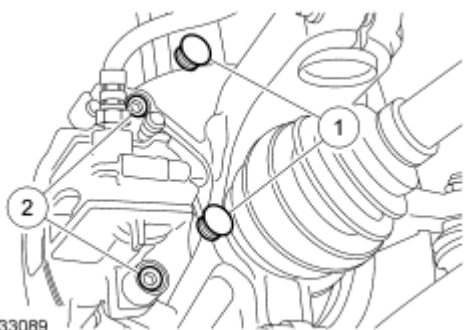

N0033089

Fig. 251: Identifying Bolt Cover And Bolts

Courtesy of FORD MOTOR CO.

CAUTION: Suspend the caliper to prevent load from being placed on the brake hose.

56. Support the brake caliper.

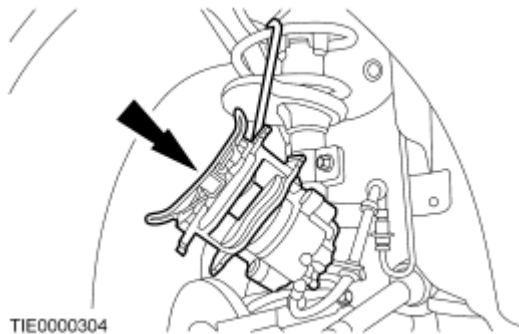

Fig. 252: Locating Brake Caliper
Courtesy of FORD MOTOR CO.

57. Loosen the LH strut and spring assembly top mount nuts by 4 turns.

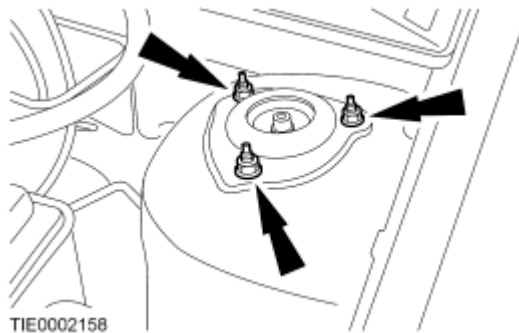

Fig. 253: Locating LH Strut And Spring Assembly Top Mount Nuts
Courtesy of FORD MOTOR CO.

58. Remove the nut and disconnect the LH stabilizer bar at the strut.

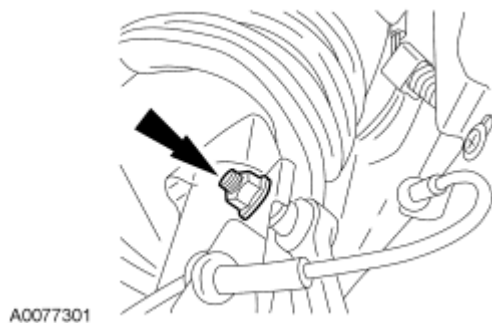

Fig. 254: Locating LH Stabilizer Bar Nut
Courtesy of FORD MOTOR CO.

59. Remove the LH tie-rod end nut.

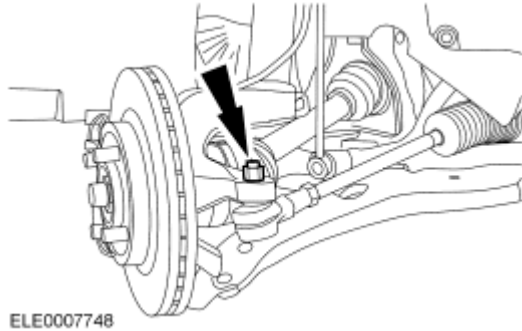

Fig. 255: Locating LH Tie-Rod End Nut
Courtesy of FORD MOTOR CO.

60. Remove the RH tie-rod end nut.

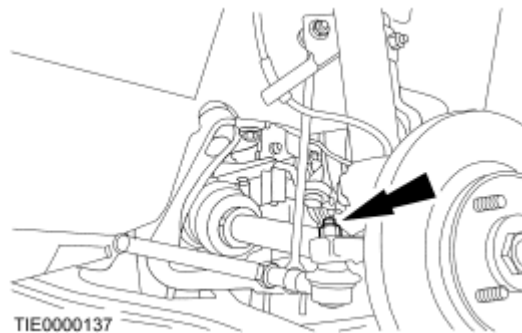

Fig. 256: Locating RH Tie-Rod End Nut
Courtesy of FORD MOTOR CO.

61. Using the special tool, disconnect both tie rods from the knuckles.

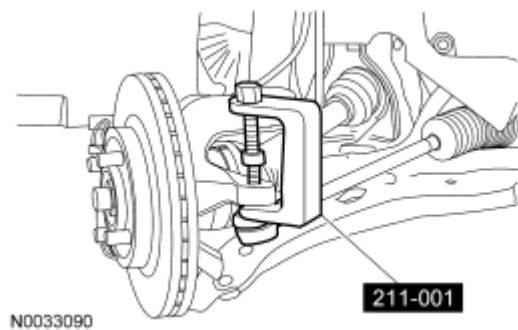
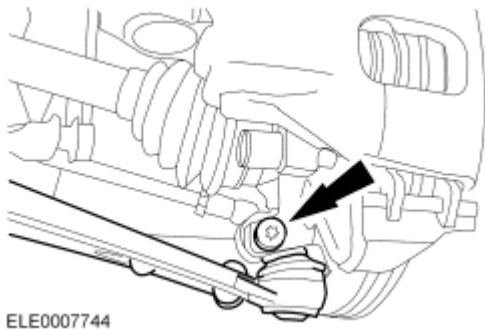

Fig. 257: Identifying Special Tool (211-001)
Courtesy of FORD MOTOR CO.

62. Remove the bolts and disconnect both lower control arms from the knuckles.



ELE0007744

Fig. 258: Locating Lower Control Arms Bolts
Courtesy of FORD MOTOR CO.

63. Remove the 2 nuts and the intermediate shaft bearing bracket.

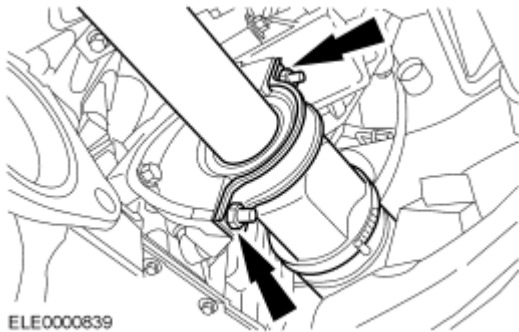

ELE0000839

Fig. 259: Locating Intermediate Shaft Bearing Bracket Nuts
Courtesy of FORD MOTOR CO.

64. Remove the intermediate shaft and RH front drive halfshaft assembly from the transaxle. Position it aside and support with mechanic's wire.
- Install a plug into the transaxle opening.

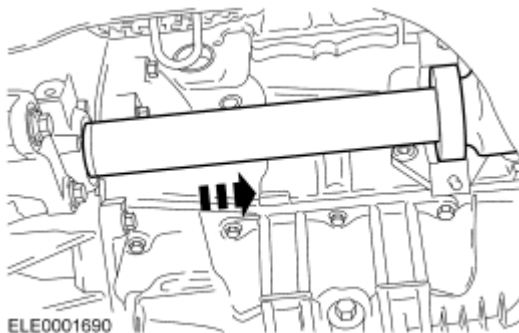

ELE0001690

Fig. 260: Removing Intermediate Shaft From Transaxle
Courtesy of FORD MOTOR CO.

65. Using the special tools, remove the LH front drive halfshaft from the transaxle. Position it aside and support with mechanic's wire.
- Install a plug into the transaxle opening.

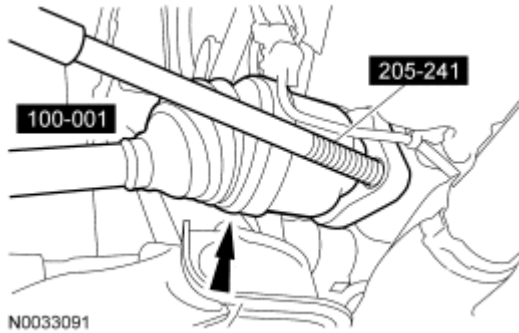

Fig. 261: Identifying Special Tools (100-001, 205-241)
 Courtesy of FORD MOTOR CO.

66. Remove the 2 bolts and the transaxle roll restrictor.

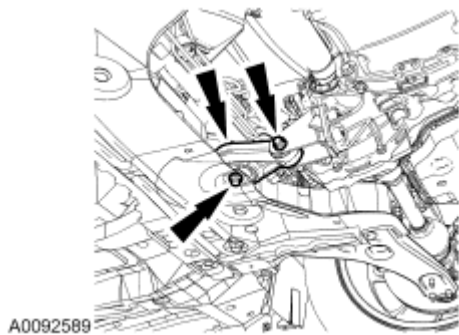

Fig. 262: Locating Transaxle Roll Restrictor And Bolts
 Courtesy of FORD MOTOR CO.

67. Remove the 3 bolts and the starter.

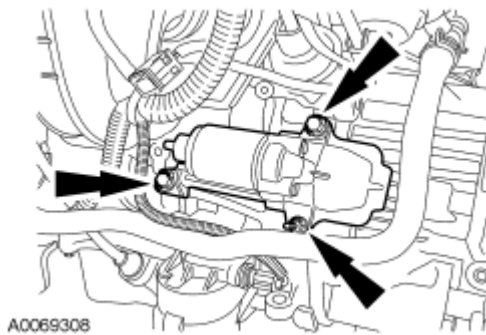

Fig. 263: Locating Starter Bolts
 Courtesy of FORD MOTOR CO.

68. Remove the starter isolator.

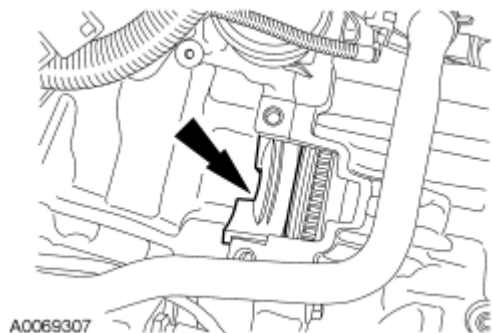

Fig. 264: Identifying Starter Motor Isolator
Courtesy of FORD MOTOR CO.

69. Remove the 2 lower bellhousing bolts.



Fig. 265: Locating Lower Bellhousing Bolts
Courtesy of FORD MOTOR CO.

70. Remove the 2 oil pan-to-bellhousing bolts.

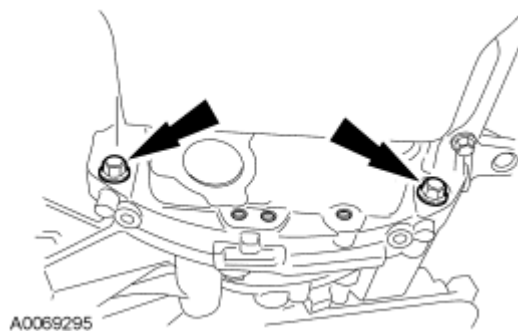
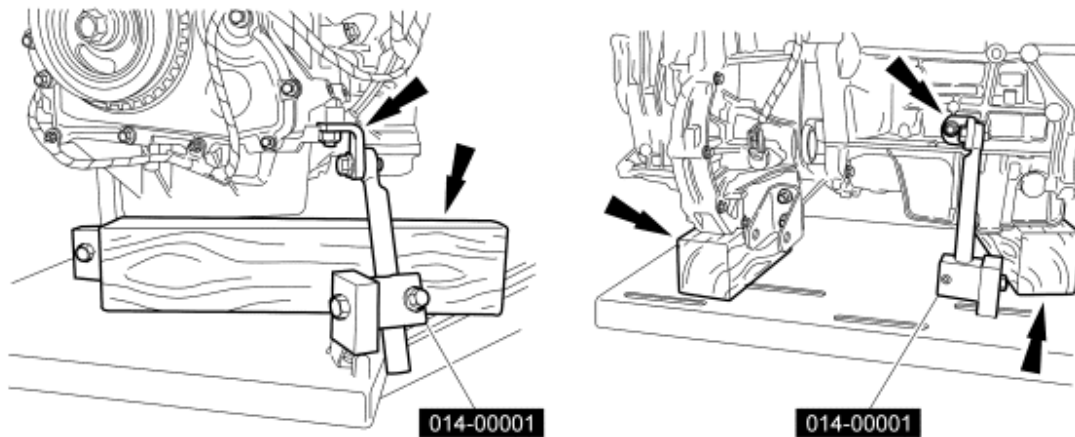

Fig. 266: Locating Oil Pan-To-Bellhousing Bolts
Courtesy of FORD MOTOR CO.

71. Using the special tools, fasten the engine to the lift table.



N0033092

Fig. 267: Identifying Special Tools (014-00001)
Courtesy of FORD MOTOR CO.

- 72. Remove the 2 engine mount nuts.

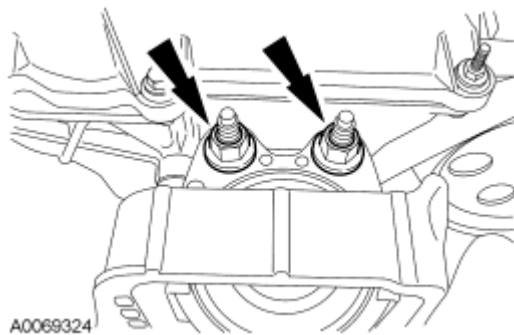

Fig. 268: Locating Engine Mount Nuts
Courtesy of FORD MOTOR CO.

- 73. Remove the transaxle mount center nut.

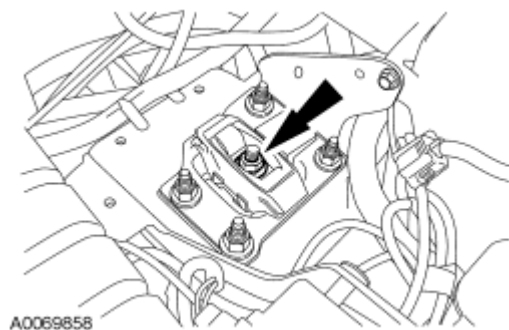

Fig. 269: Locating Transaxle Mount Center Nut
Courtesy of FORD MOTOR CO.

74. Lower the engine and transaxle assembly from the vehicle.

Vehicles equipped with a manual transmission

75. Disconnect the vehicle speed sensor (VSS) electrical connector.

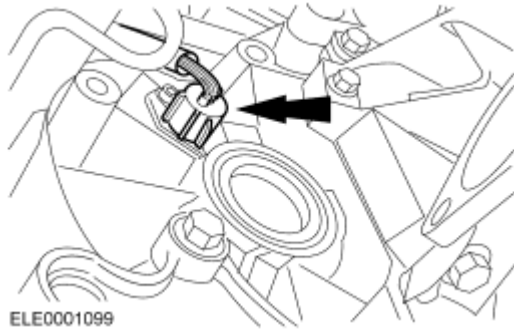

Fig. 270: Locating Vehicle Speed Sensor Electrical Connector
Courtesy of FORD MOTOR CO.

Vehicles equipped with a 2.0L engine and automatic transmission

NOTE: Mark one stud and the flexplate for assembly reference.

76. Remove the 4 torque converter nuts.



Fig. 271: Locating Torque Converter Nut
Courtesy of FORD MOTOR CO.

77. Disconnect the output shaft speed (OSS) sensor electrical connector.

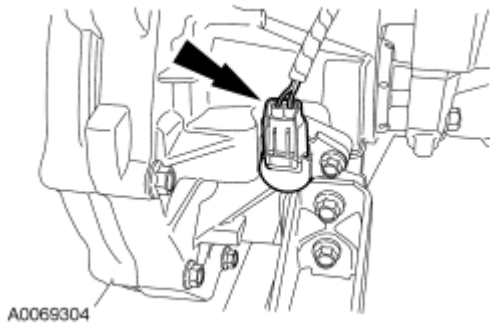

Fig. 272: Locating Output Shaft Speed Sensor Electrical Connector
Courtesy of FORD MOTOR CO.

78. Disconnect the turbine shaft speed (TSS) sensor electrical connector.

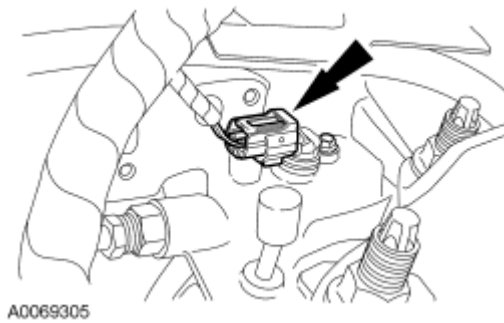

Fig. 273: Locating Turbine Shaft Speed (TSS) Sensor Electrical Connector
Courtesy of FORD MOTOR CO.

79. Disconnect the solenoid body and the transmission range (TR) sensor electrical connectors.

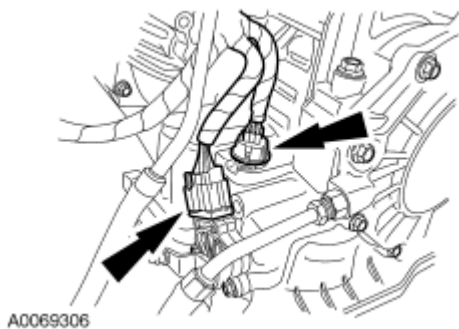

Fig. 274: Locating Transmission Range Sensor Electrical Connectors
Courtesy of FORD MOTOR CO.

All vehicles

NOTE: Lower the engine to within a few inches of the floor.

80. Using the engine crane, remove the engine and transaxle assembly from the lift table.

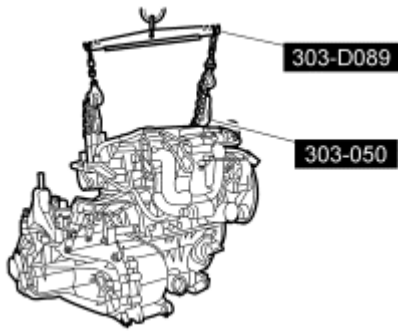

Fig. 275: Identifying Special Tools (303-D089, 303-050)
Courtesy of FORD MOTOR CO.

- 81. Remove the remaining bellhousing bolts and separate the engine and transmission.
- 82. Remove and discard the dowel pins.

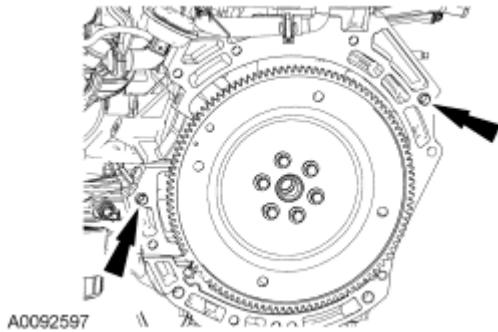

Fig. 276: Locating Dowel Pins
Courtesy of FORD MOTOR CO.

Vehicles equipped with a 2.0L engine and automatic transmission

83. Install the special tool, to prevent damage to the torque converter.

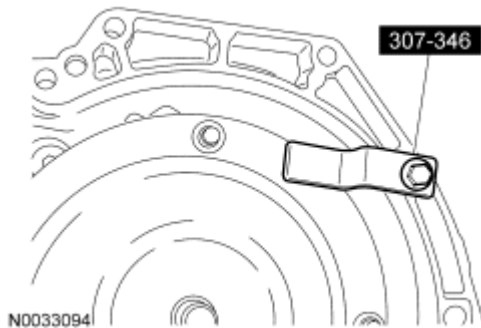





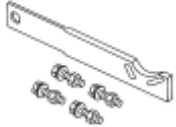

Fig. 277: Identifying Special Tool (307-346)
Courtesy of FORD MOTOR CO.

2007 Ford Focus S



2007 ENGINE Engine - 2.0L and 2.3L - Focus

DISASSEMBLY**ENGINE****Special Tools**

Illustration	Tool Name	Tool Number
 ST1341-A	Heavy Duty Floor Crane	014-00071 or equivalent
 ST1602-A	Spreader Bar	303-D089 (D93P-6001-A3) or equivalent
 ST2768-A	Locking Tool, Flywheel	303-103 (T74P-8375-A)
 ST1910-A	Engine Stand	014-00232 or equivalent
 ST2645-A	Alignment Plate, Camshaft	303-465 (T94P-6256-CH)
 ST2638-A	Timing Peg, Crankshaft	303-507
 ST2647-A	Holding Fixture, Drive Pinion Flange	205-126 (T78P-4851-A)

2007 Ford Focus S

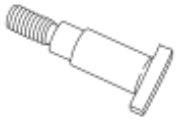
2007 ENGINE Engine - 2.0L and 2.3L - Focus

 ST2639-A	Adapter for 205-126	(205-072-02)
 ST1385-A	Remover, Oil Seal	303-409 (T92C-6700-CH)

CAUTION: Do not loosen or remove the crankshaft pulley bolt without first installing the special tools as instructed in this procedure. The crankshaft pulley and the crankshaft timing sprocket are not keyed to the crankshaft. The crankshaft, the crankshaft sprocket and the pulley are fitted together by friction, using diamond washers between the flange faces on each part. For that reason, the crankshaft sprocket is also unfastened if the pulley bolt is loosened. Before any repair requiring loosening or removal of the crankshaft pulley bolt, the crankshaft and camshafts must be locked in place by the special service tools, otherwise severe engine damage can occur.

CAUTION: During engine repair procedures, cleanliness is extremely important. Any foreign material, including any material created while cleaning gasket surfaces that enters the oil passages, coolant passages or the oil pan, can cause engine failure.

CAUTION: Due to the precision fit and timing of the balancer shaft assembly, it cannot be removed from the engine block.

NOTE: For additional information, refer to the exploded view under the assembly procedure in this article.

NOTE: Early build engines are equipped with an oil pump drive chain guide. Late build engines do not have an oil pump drive chain guide. Also, late build engines use an updated design for the oil pump drive chain and tensioner. Therefore, the oil pump drive components are not interchangeable between early build and late build engines.

Vehicles equipped with a manual transmission

WARNING: The clutch disc and clutch pressure plate are heavy and may fall if not held when the bolts are removed. Failure to follow these

instructions may result in personal injury.

CAUTION: Loosen the bolts evenly to prevent pressure plate damage.

1. Remove the 7 bolts, clutch pressure plate and clutch disc.

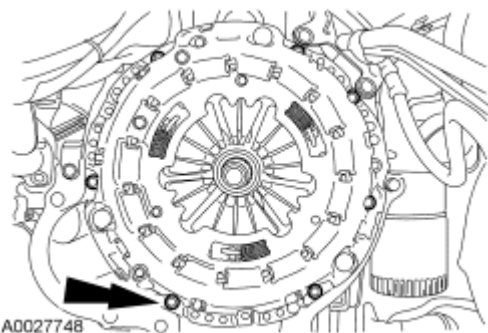

Fig. 278: Locating Clutch Pressure Plate Bolts
Courtesy of FORD MOTOR CO.

All vehicles

2. Install the special tool and remove the flywheel or flexplate.

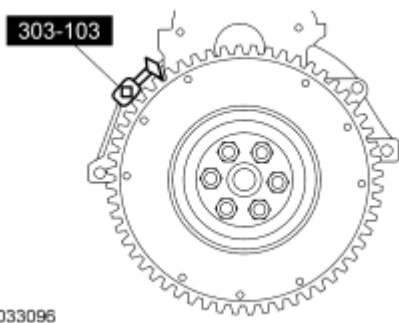

Fig. 279: Identifying Special Tool (303-103)
Courtesy of FORD MOTOR CO.

3. Mount the engine on a suitable engine stand.
4. Disconnect the crankshaft position (CKP) sensor and the wiring harness pin-type retainers.

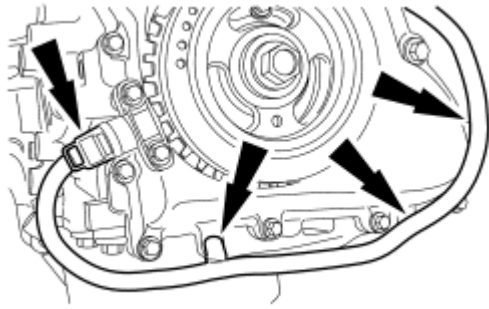

Fig. 280: Locating Crankshaft Position Sensor And Wiring Harness Pin-Type Retainers
Courtesy of FORD MOTOR CO.

5. Remove the 3 nuts and the generator heat shield.

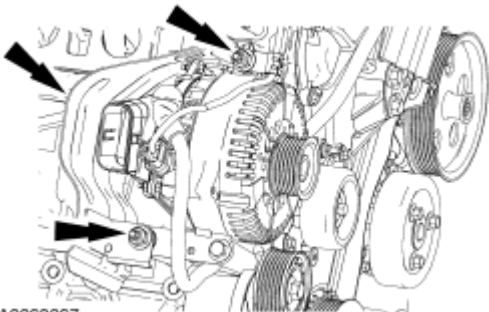

Fig. 281: Locating Generator Heat Shield And Nuts
Courtesy of FORD MOTOR CO.

6. Remove the nut and disconnect the generator electrical connections and wiring harness retainer.

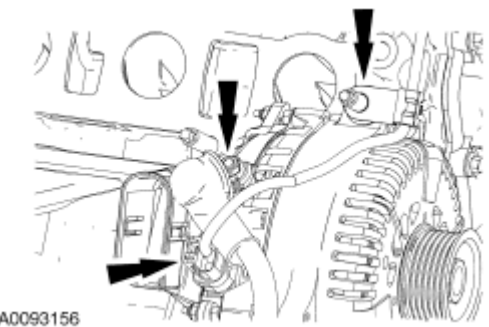

Fig. 282: Locating Generator Electrical Connections And Wiring Harness Retainer
Courtesy of FORD MOTOR CO.

7. Remove the nut and the wiring harness retainer.

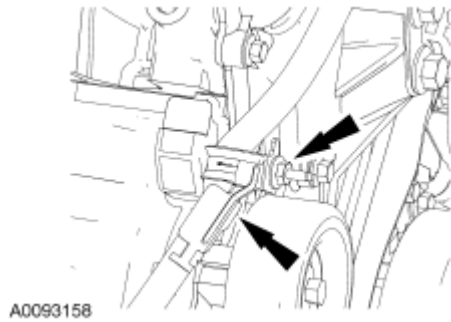

Fig. 283: Locating Wiring Harness Retainer And Nut
Courtesy of FORD MOTOR CO.

8. Remove the bolt, the 2 stud bolts and the generator.

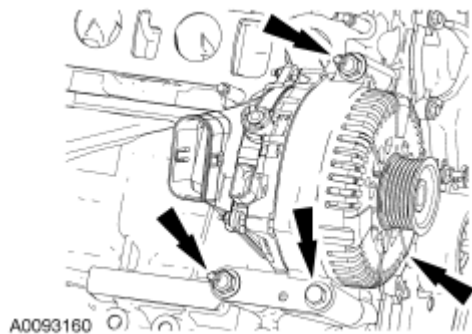

Fig. 284: Locating Generator And Bolts
Courtesy of FORD MOTOR CO.

9. Remove the 2 bolts and the accessory drive belt tensioner.

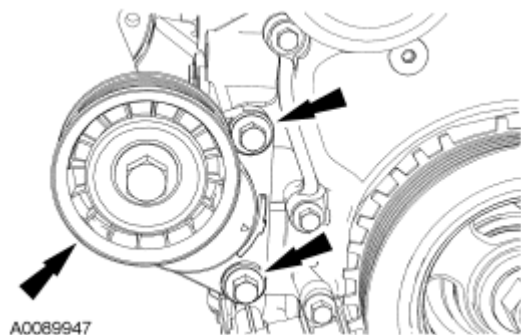

Fig. 285: Locating Accessory Drive Belt Tensioner Bolts
Courtesy of FORD MOTOR CO.

10. Loosen the bolt and remove the accessory drivebelt idler pulley.

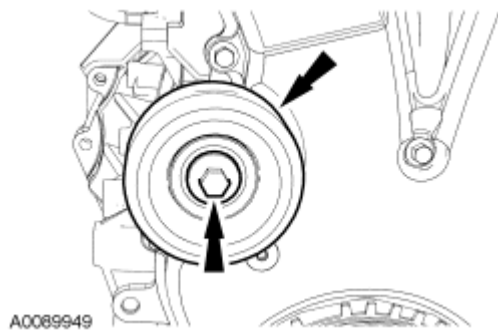

Fig. 286: Locating Accessory Drivebelt Idler Pulley And Bolt
Courtesy of FORD MOTOR CO.

11. If equipped, loosen the bolt and remove the accessory drive belt idler pulley.

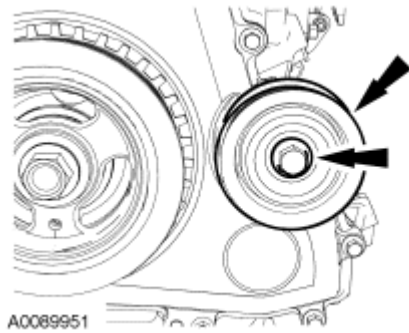

Fig. 287: Locating Accessory Drive Belt Idler Pulley And Bolt
Courtesy of FORD MOTOR CO.

12. Remove the 3 bolts and the coolant pump pulley.

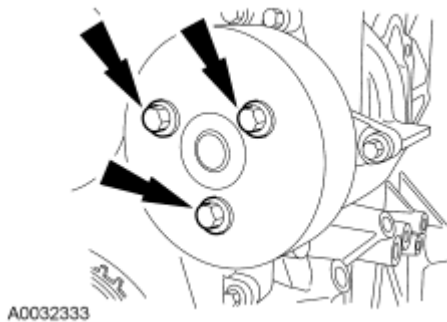
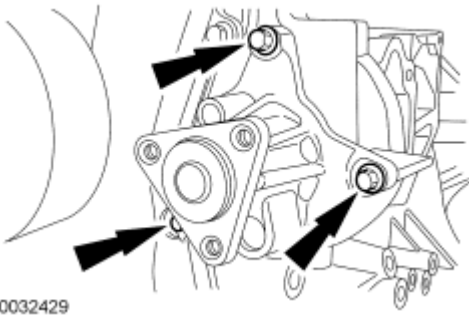

Fig. 288: Locating Coolant Pump Pulley Bolts
Courtesy of FORD MOTOR CO.

13. Remove the 3 bolts and the coolant pump.



A0032429

Fig. 289: Locating Coolant Pump Bolts
Courtesy of FORD MOTOR CO.

14. Disconnect the heater hose from the thermostat housing.

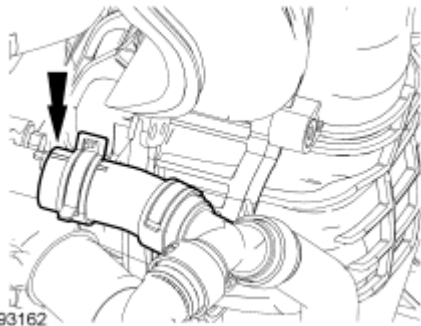

A0093162

Fig. 290: Locating Heater Hose
Courtesy of FORD MOTOR CO.

15. Remove the 3 bolts and the thermostat housing.

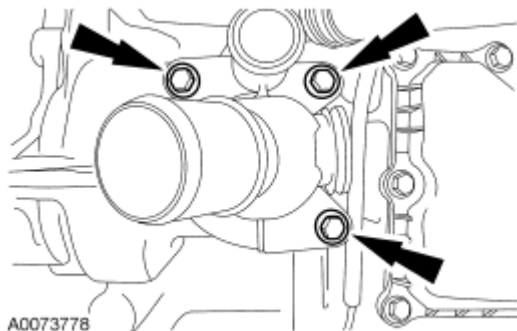

A0073778

Fig. 291: Locating Thermostat Housing Bolts
Courtesy of FORD MOTOR CO.

16. Disconnect the oil pressure sensor electrical connector.

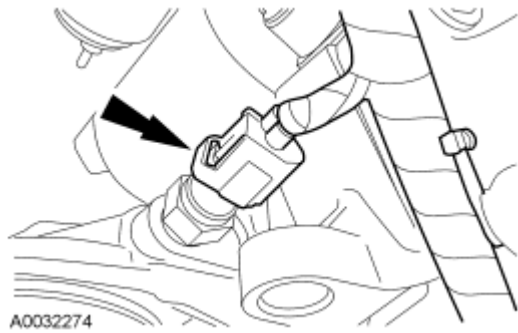

Fig. 292: Locating Engine Oil Pressure (EOP) Sensor Electrical Connector
Courtesy of FORD MOTOR CO.

17. Remove the engine oil filter.

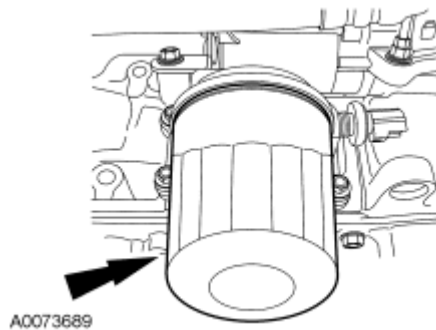

Fig. 293: Locating Engine Oil Filter
Courtesy of FORD MOTOR CO.

18. Remove the 4 bolts and the oil filter adapter.
 - Discard the gasket.

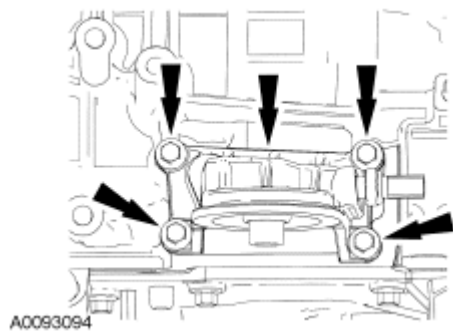

Fig. 294: Locating Oil Filter Adapter And Bolts
Courtesy of FORD MOTOR CO.

19. Disconnect the knock sensor (KS) electrical connector and pin-type retainer.

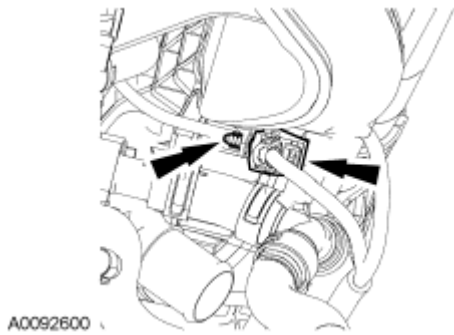

Fig. 295: Locating Knock Sensor Electrical Connector And Pin-Type Retainer
Courtesy of FORD MOTOR CO.

20. Remove the lower intake manifold bolt.



Fig. 296: Locating Lower Intake Manifold Bolt
Courtesy of FORD MOTOR CO.

21. Disconnect the throttle position (TP) sensor electrical connector and wiring harness pin-type retainer.

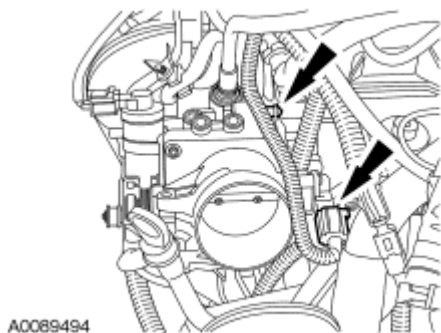

Fig. 297: Locating Throttle Position Sensor Electrical Connector And Wiring Harness Pin-Type Retainer
Courtesy of FORD MOTOR CO.

22. Disconnect the idle air control (IAC) valve electrical connector and wiring harness pin-type retainer.

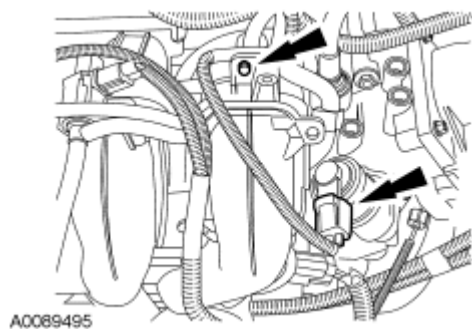

Fig. 298: Locating Idle Air Control Valve Electrical Connector And Wiring Harness Pin-Type Retainer
Courtesy of FORD MOTOR CO.

23. Disconnect the fuel rail pressure and temperature sensor vacuum hose.

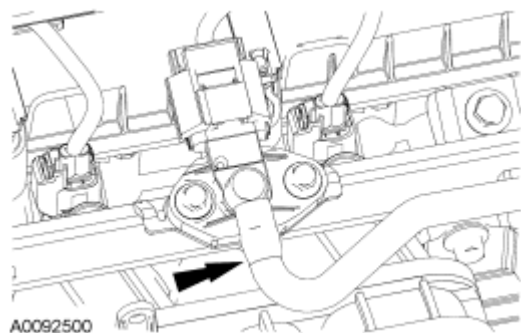

Fig. 299: Locating Fuel Rail Pressure And Temperature Sensor Vacuum Hose
Courtesy of FORD MOTOR CO.

24. Detach the wiring harness pin-type retainer.

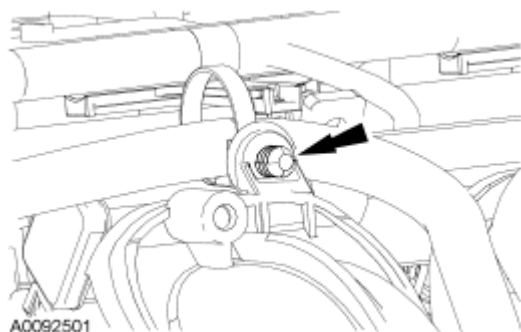

Fig. 300: Locating Wiring Harness Pin-Type Retainer
Courtesy of FORD MOTOR CO.

25. Disconnect the intake manifold runner control (IMRC) actuator electrical connector.

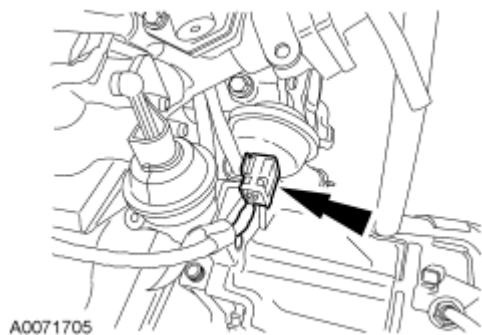

Fig. 301: Locating Intake Manifold Runner Control Actuator Electrical Connector
Courtesy of FORD MOTOR CO.

26. Disconnect the manifold absolute pressure (MAP) sensor electrical connector.



Fig. 302: Locating Manifold Absolute Pressure Sensor Electrical Connector
Courtesy of FORD MOTOR CO.

2.0L engines

27. If equipped, disconnect the secondary air injection (AIR) vacuum supply hose.

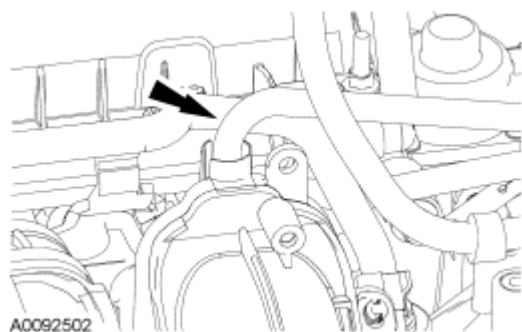

Fig. 303: Locating Secondary Air Injection Vacuum Supply Hose
Courtesy of FORD MOTOR CO.

28. Disconnect the swirl control valve electrical connector.

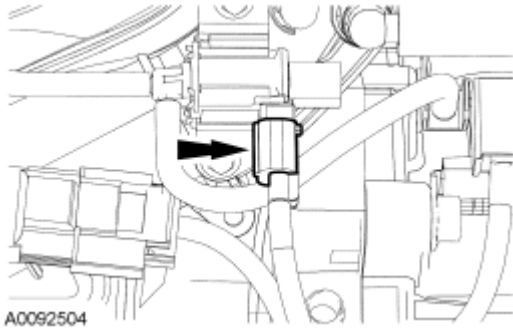

Fig. 304: Locating Swirl Control Valve Electrical Connector
Courtesy of FORD MOTOR CO.

29. Remove the bolt and the oil level indicator tube.

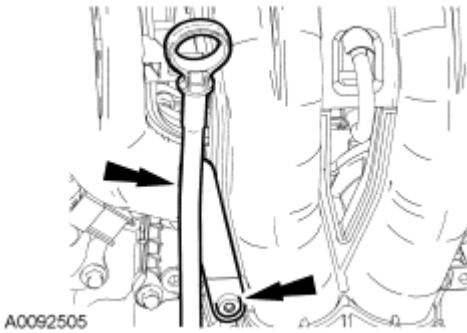

Fig. 305: Locating Bolt And Oil Level Indicator Tube
Courtesy of FORD MOTOR CO.

NOTE: There are 3 different size bolts used. Mark the location of the bolts to make sure of correct installation.

30. Remove the 7 intake manifold bolts.

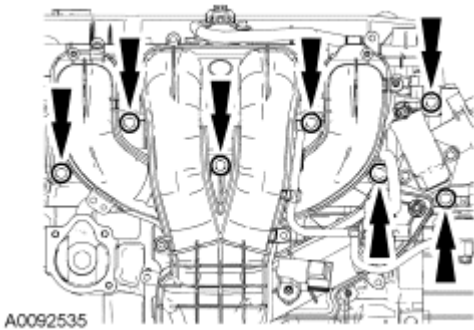

Fig. 306: Locating Intake Manifold Bolts
Courtesy of FORD MOTOR CO.

2.3L engines

31. Disconnect the swirl valve electrical connectors and pin-type retainers.

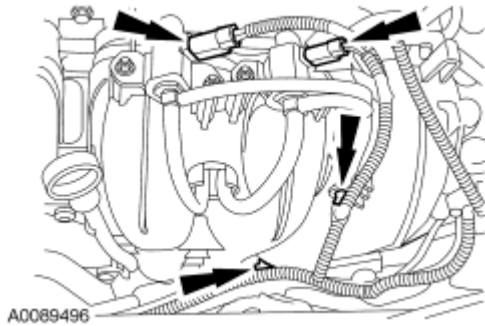

Fig. 307: Locating Swirl Valve Electrical Connectors And Pin-Type Retainers
Courtesy of FORD MOTOR CO.

32. Remove the 2 bolts and the oil level indicator and tube.

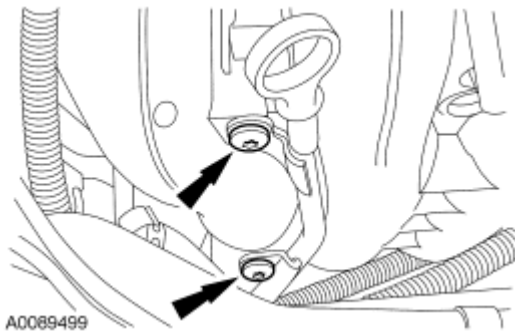

Fig. 308: Locating Oil Level Indicator Tube Bolts
Courtesy of FORD MOTOR CO.

NOTE: There are 3 different size bolts used. Mark the location of the bolts to make sure of correct installation.

33. Remove the 7 intake manifold bolts.

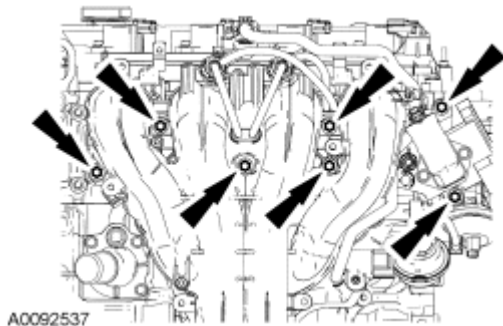

Fig. 309: Locating Intake Manifold Bolts
Courtesy of FORD MOTOR CO.

All engines

34. Disconnect the positive crankcase ventilation (PCV) hose and remove the intake manifold.

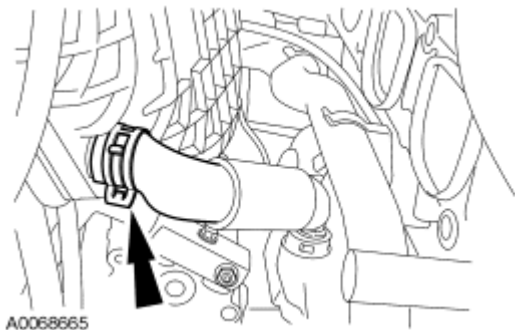

Fig. 310: Locating Positive Crankcase Ventilation Hose
Courtesy of FORD MOTOR CO.

35. Remove the exhaust gas recirculation (EGR) tube.

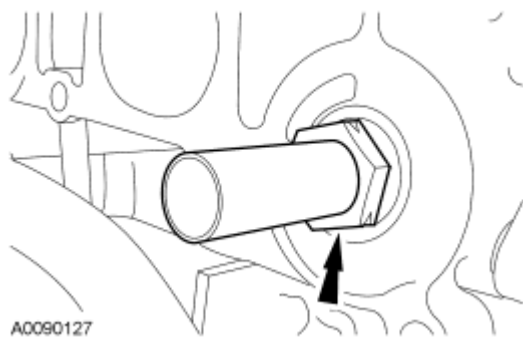

Fig. 311: Locating Exhaust Gas Recirculation Tube
Courtesy of FORD MOTOR CO.

36. Remove the radio interference capacitor bracket bolt and position the bracket aside.

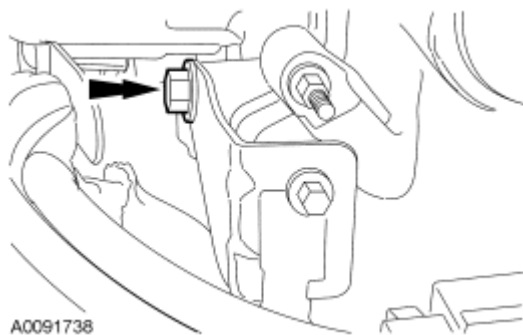

Fig. 312: Locating Radio Interference Capacitor Bracket Bolt
Courtesy of FORD MOTOR CO.

37. Disconnect the wiring harness retainers from the valve cover studs and position aside.

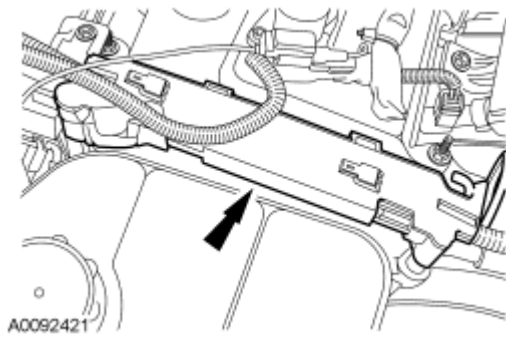

Fig. 313: Locating Wiring Harness Retainers
Courtesy of FORD MOTOR CO.

38. Disconnect the fuel charging wiring harness.
- Disconnect the fuel rail pressure and temperature sensor electrical connector.
 - Disconnect the 4 fuel injector electrical connectors.
 - Detach the wiring harness retainers.



Fig. 314: Locating Fuel Charging Wiring Harness
Courtesy of FORD MOTOR CO.

39. Remove the 2 bolts and the fuel rail with the fuel injectors.

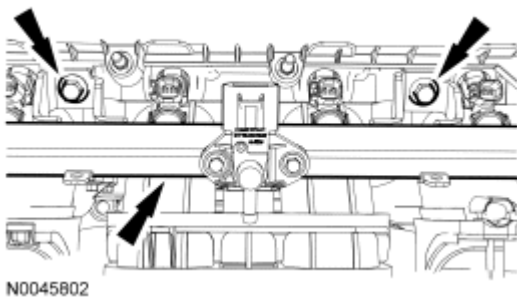

Fig. 315: Locating Fuel Rail Bolts And Fuel Rail
Courtesy of FORD MOTOR CO.

40. Disconnect the coil-on-plug and camshaft position (CMP) sensor electrical connectors.

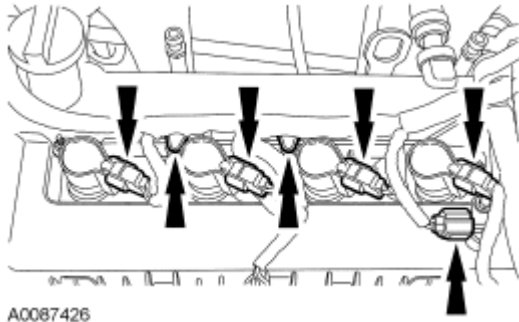

Fig. 316: Locating Camshaft Position Sensor Electrical Connectors And Coil-On-Plug
Courtesy of FORD MOTOR CO.

41. Position the rubber boot aside and disconnect the cylinder head temperature (CHT) sensor electrical connector. Remove the wiring harness from the engine.

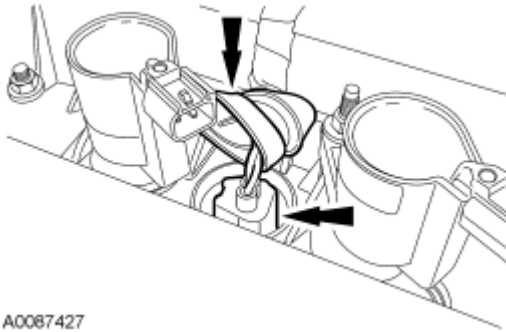

Fig. 317: Locating Cylinder Head Temperature Sensor Electrical Connector And Rubber Boot
Courtesy of FORD MOTOR CO.

42. Disconnect and remove the coolant hose.

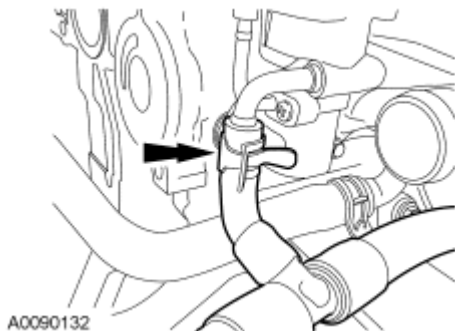

Fig. 318: Locating Coolant Hose
Courtesy of FORD MOTOR CO.

43. Disconnect the coolant bypass hose.

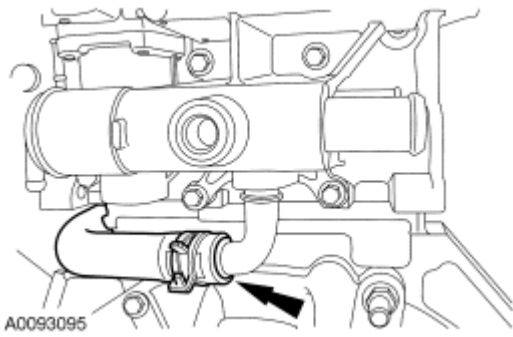

Fig. 319: Locating Coolant Bypass Hose
Courtesy of FORD MOTOR CO.

- 44. Remove the 4 bolts and the coolant bypass.

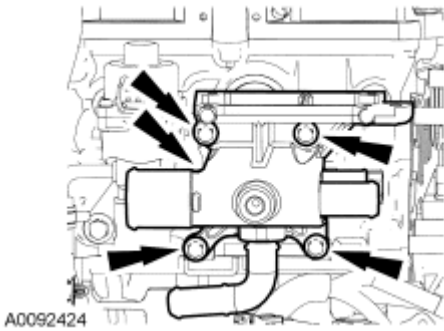

Fig. 320: Locating Coolant Bypass And Bolts
Courtesy of FORD MOTOR CO.

- 45. Disconnect and remove the coolant bypass hose.

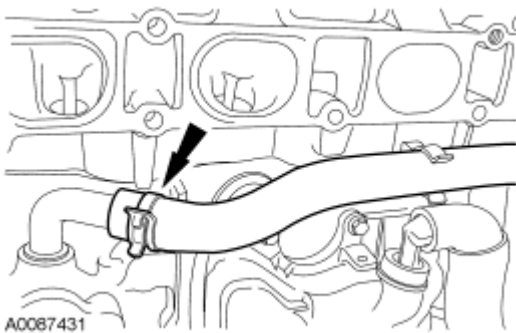

Fig. 321: Locating Coolant Bypass Hose
Courtesy of FORD MOTOR CO.

- 46. Remove the bolt and the KS.

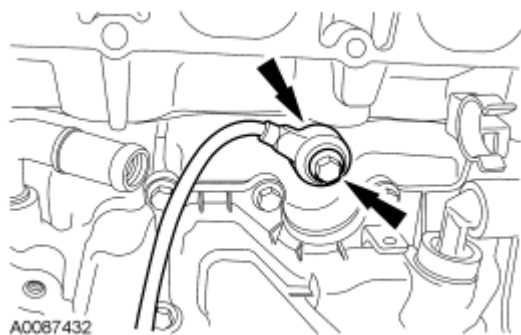

Fig. 322: Locating KS And Bolt
Courtesy of FORD MOTOR CO.

47. Remove the 8 bolts and the crankcase vent oil separator.

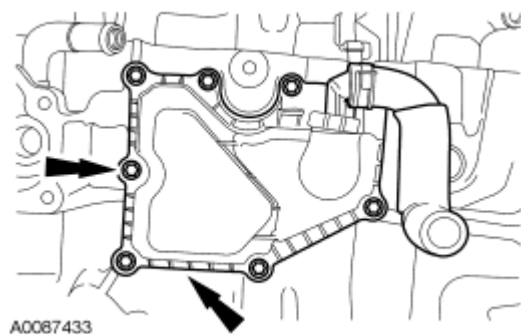

Fig. 323: Locating Crankcase Vent Oil Separator And Bolts
Courtesy of FORD MOTOR CO.

48. If equipped, remove the block heater.

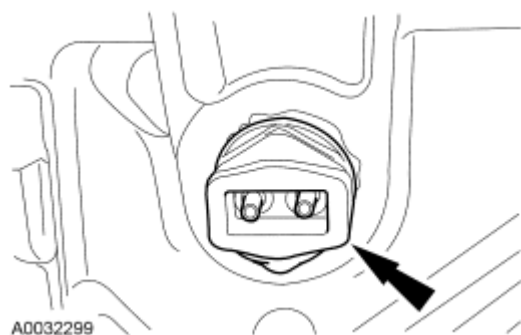

Fig. 324: Locating Block Heater
Courtesy of FORD MOTOR CO.

49. Remove the crankcase vent tube and the coil-on-plugs.

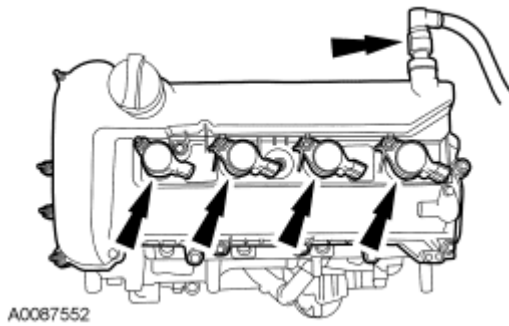

Fig. 325: Locating Crankcase Vent Tube And Coil-On-Plugs
 Courtesy of FORD MOTOR CO.

CAUTION: Only use hand tools when removing or installing the spark plugs, damage can occur to the cylinder head or spark plug.

50. Remove the spark plugs and the CHT sensor.
 - Discard the CHT.

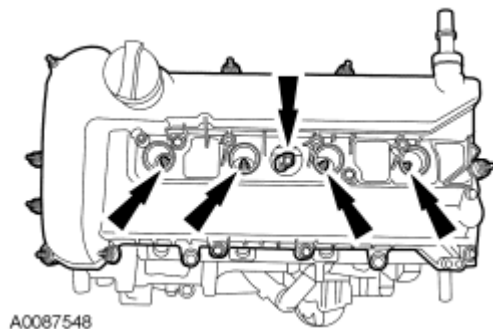

Fig. 326: Locating Cylinder Head Temperature Sensor And Spark Plugs
 Courtesy of FORD MOTOR CO.

51. Remove the bolts and the valve cover.

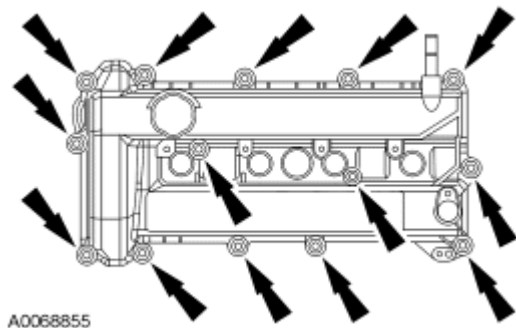

Fig. 327: Locating Valve Cover Bolts
 Courtesy of FORD MOTOR CO.

CAUTION: Failure to position the No. 1 piston at top dead center (TDC) can result in damage to the engine. Turn the engine in the normal direction of rotation only.

52. Using the crankshaft pulley bolt, turn the crankshaft clockwise to position the No. 1 piston at TDC.
- The hole in the crankshaft pulley should be in the 6 o'clock position.

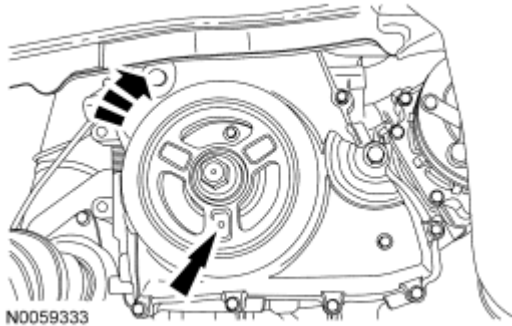

Fig. 328: Turning Crankshaft Clockwise
Courtesy of FORD MOTOR CO.

CAUTION: The special tool 303-465 is for camshaft alignment only. Using this tool to prevent engine rotation can result in engine damage.

NOTE: The camshaft timing slots are offset. If the special tool cannot be installed, rotate the crankshaft one complete revolution clockwise to correctly position the camshafts.

53. Install the special tool in the slots on the rear of both camshafts.

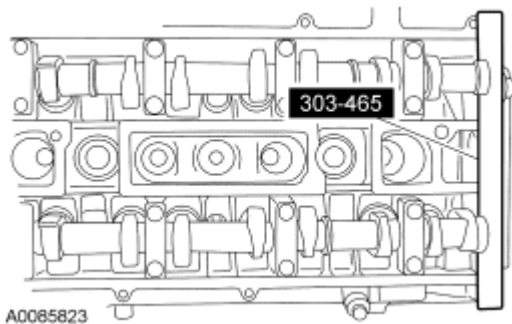

Fig. 329: Identifying Special Camshaft Tool (303-465)
Courtesy of FORD MOTOR CO.

54. Remove the engine plug bolt.

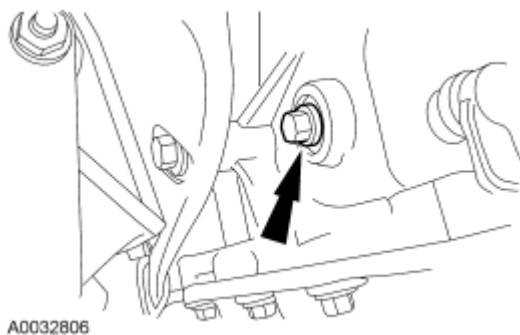

Fig. 330: Locating Engine Plug Bolt
Courtesy of FORD MOTOR CO.

NOTE: The special tool will contact the crankshaft and prevent it from turning past TDC. However, the crankshaft can still be rotated in the counterclockwise direction. The crankshaft must remain at the TDC position during disassembly.

55. Install the special tool.

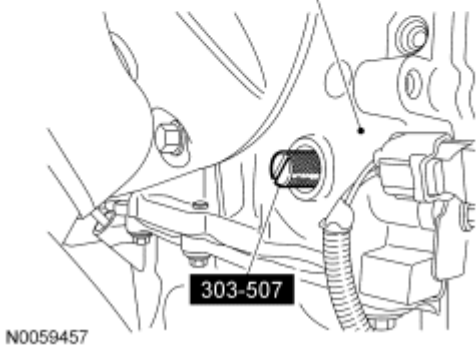
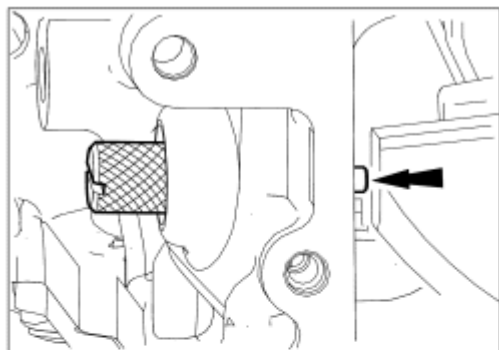
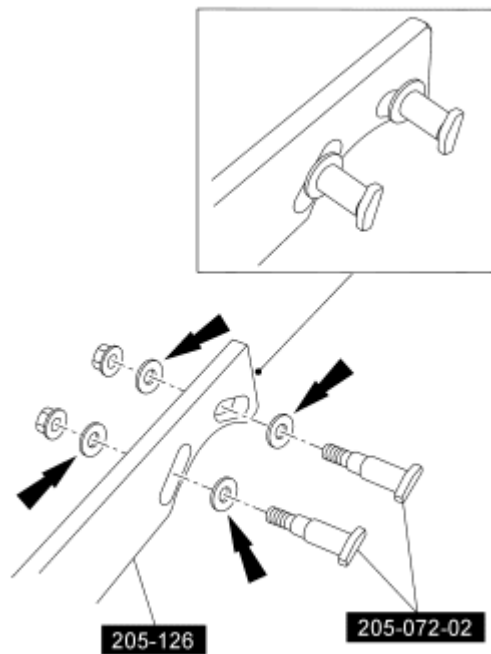

Fig. 331: Identifying Special Tool (303-507)
Courtesy of FORD MOTOR CO.

56. Assemble the special tools using 4 hardened washers in the locations shown.



N0059334

Fig. 332: Assembling Special Tools (205-126 And 205-072-02) And Hardened Washers
 Courtesy of FORD MOTOR CO.

CAUTION: The crankshaft must remain in the TDC position during removal of the pulley bolt or damage to the engine can occur. Therefore, the crankshaft pulley must be held in place with the special tool and the bolt should be removed using an air impact wrench (1/2-in drive minimum).

CAUTION: The crankshaft sprocket diamond washer may come off with the crankshaft pulley. The diamond washer must be replaced; remove and discard the diamond washer. If the diamond washer is not installed, engine damage may occur.

57. Using the special tools and an air impact wrench, remove the crankshaft pulley.
- Remove and discard the crankshaft pulley bolt and washer.
 - Remove the crankshaft pulley.
 - Remove the diamond washer and discard.

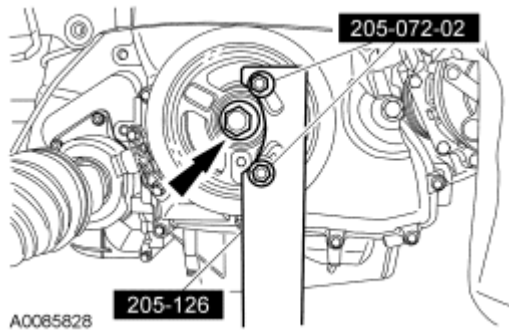

Fig. 333: Using Special Tools (205-126 And 205-072-02)
 Courtesy of FORD MOTOR CO.

CAUTION: Use care not to damage the engine front cover or the crankshaft when removing the seal.

58. Using the special tool, remove the crankshaft front oil seal.

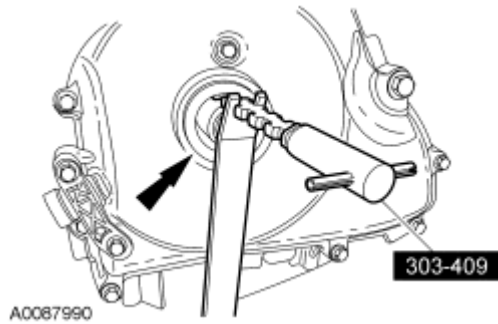

Fig. 334: Identifying Special Tool (303-409) And Crankshaft Front Oil Seal
 Courtesy of FORD MOTOR CO.

NOTE: Whenever the CKP sensor is removed, a new one must be installed using the alignment jig supplied with the new part.

59. Remove and discard the CKP sensor.

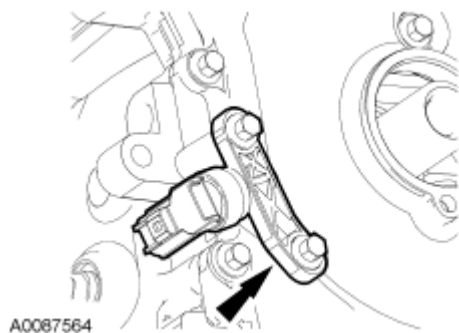
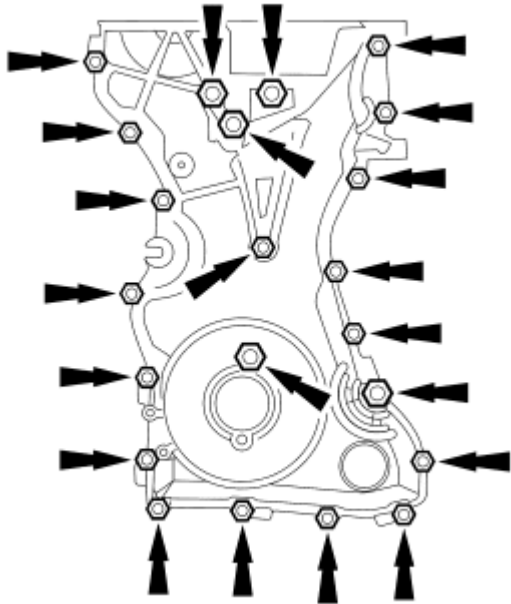

Fig. 335: Locating CKP Sensor

Courtesy of FORD MOTOR CO.

60. Remove the 22 bolts and the engine front cover.



A0087412

Fig. 336: Locating Engine Front Cover Bolts
Courtesy of FORD MOTOR CO.

61. Remove the timing chain tensioner.
1. Compress the timing chain tensioner, and insert a paper clip into the hole to retain the tensioner.
 2. Remove the 2 bolts and timing chain tensioner.

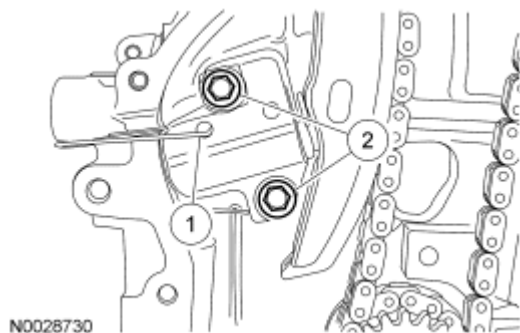

N0028730

Fig. 337: Identifying Paper Clip Into Hole And Bolts
Courtesy of FORD MOTOR CO.

62. Remove the RH timing chain guide.

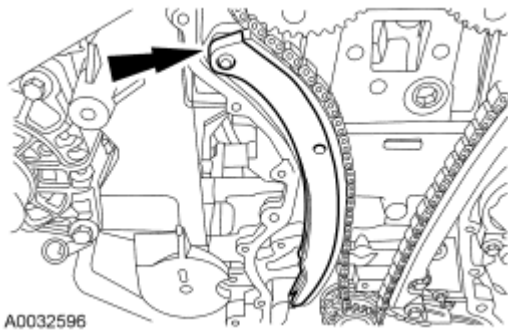

Fig. 338: Locating RH Timing Chain Guide
Courtesy of FORD MOTOR CO.

63. Remove the timing chain.

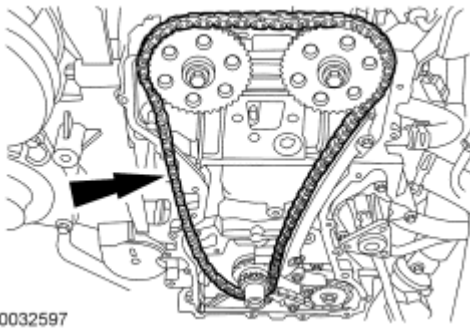

Fig. 339: View Of Timing Chain
Courtesy of FORD MOTOR CO.

64. Remove the 2 bolts and the LH timing chain guide.

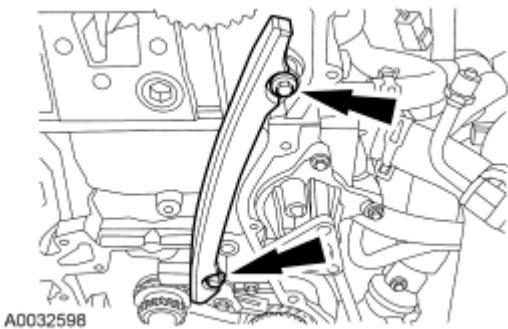

Fig. 340: Identifying Bolts And LH Timing Chain Guide
Courtesy of FORD MOTOR CO.

CAUTION: Do not rely on the Camshaft Alignment Plate to prevent camshaft rotation. Damage to the tool or the camshaft can occur.

65. Using the flats on the camshaft to prevent camshaft rotation, remove the bolts and the camshaft sprockets.

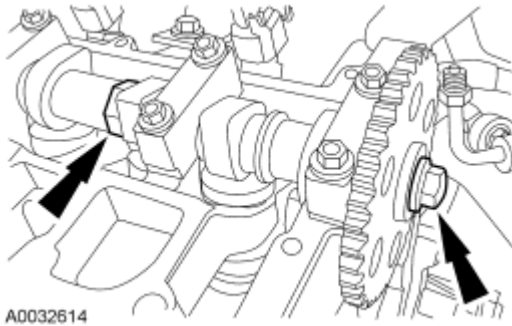

Fig. 341: Locating Cam Holding Area And Sprocket Bolt
 Courtesy of FORD MOTOR CO.

Early build vehicles

66. Remove the oil pump drive chain tensioner and guide.
 1. Release the tension on the tensioner spring.
 2. Remove the tensioner and the shoulder bolt.
 3. Remove the guide.

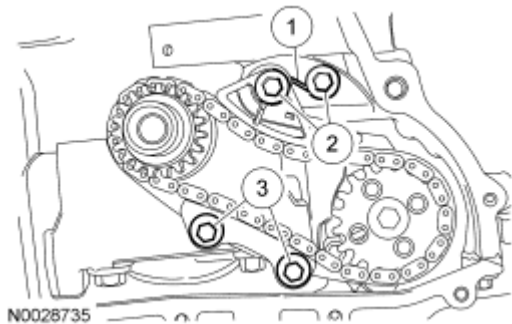

Fig. 342: Locating Oil Pump Bolts
 Courtesy of FORD MOTOR CO.

Late build vehicles

67. Remove the oil pump drive chain tensioner.
 1. Release the tension on the tensioner spring.
 2. Remove the tensioner and the 2 shoulder bolts.

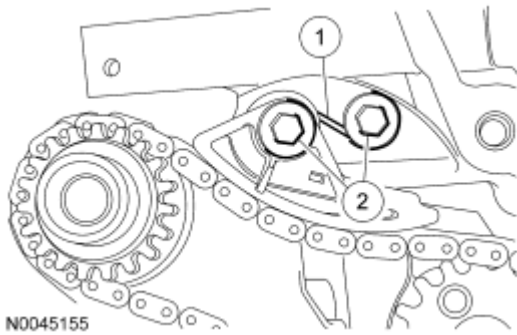

Fig. 343: Locating Shoulder Bolts & Tensioner
 Courtesy of FORD MOTOR CO.

All vehicles

NOTE: Remove and discard the crankshaft sprocket diamond washer located behind the crankshaft sprocket.

NOTE: The oil pump chain sprocket must be held in place.

68. Remove the oil pump chain and sprockets.
 1. Remove the bolt.
 2. Remove the chain and sprockets.

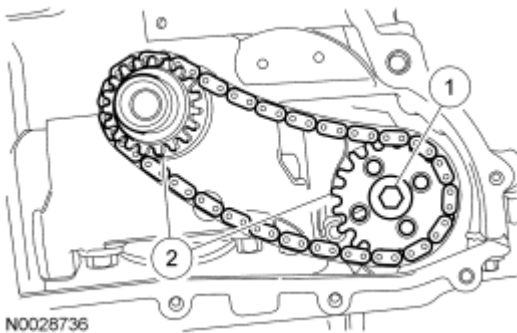

Fig. 344: Identifying Bolt, Chain And Sprockets
 Courtesy of FORD MOTOR CO.

69. Mark the position of the camshaft lobes on the No. 1 cylinder for assembly reference.

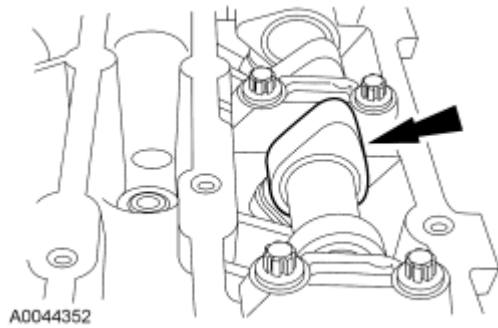

Fig. 345: Locating Camshaft Lobe
Courtesy of FORD MOTOR CO.

CAUTION: Failure to follow the camshaft loosening procedure can result in damage to the camshafts.

NOTE: Mark the location and orientation of each camshaft bearing cap.

70. Remove the camshafts from the engine.
- Loosen the camshaft bearing bolts in the sequence shown, one turn at a time. Repeat until all the tension is released.
 - Remove the camshaft bearing caps.
 - Remove the camshafts.

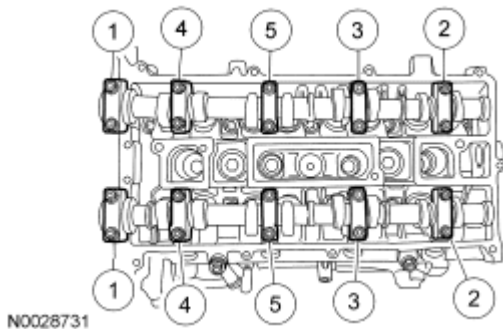
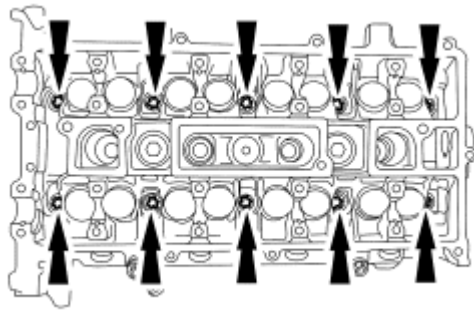

Fig. 346: Identifying Loosening/Tightening Sequence Of Camshaft Bearing Bolts
Courtesy of FORD MOTOR CO.

71. Remove the cylinder head.
- Remove and discard the 10 cylinder head bolts.
 - Remove the cylinder head.
 - Remove and discard the cylinder head gasket.



A0032440

Fig. 347: Locating Cylinder Head Bolts
Courtesy of FORD MOTOR CO.

72. Remove the cylinder head alignment dowels.

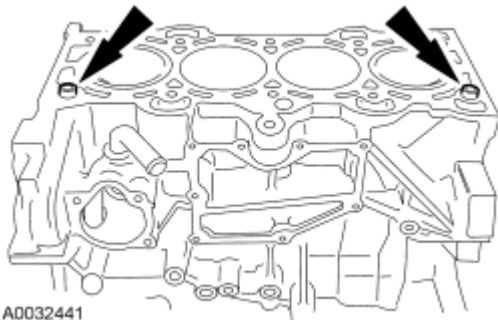

A0032441

Fig. 348: Identifying Cylinder Head Alignment Dowels
Courtesy of FORD MOTOR CO.

73. Remove the 13 bolts and the oil pan.

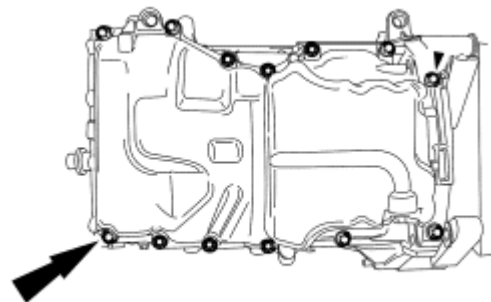

A0043114

Fig. 349: Locating Oil Pan Bolts
Courtesy of FORD MOTOR CO.

74. Remove the 6 bolts and the rear crankshaft seal.

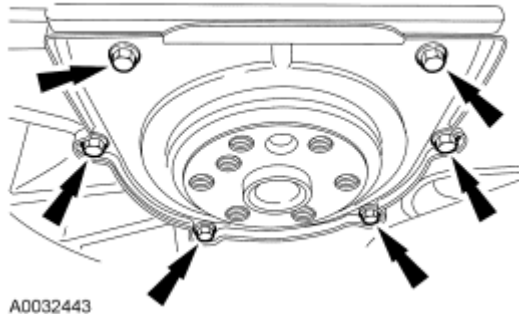

Fig. 350: Locating Rear Crankshaft Seal Bolts
Courtesy of FORD MOTOR CO.

75. Remove the 2 bolts, oil pump pickup tube and gasket.

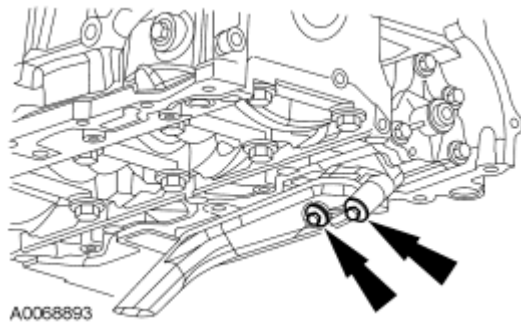

Fig. 351: Locating Oil Pump Pickup Tube Bolts
Courtesy of FORD MOTOR CO.

76. Remove the 4 bolts and the oil pump.

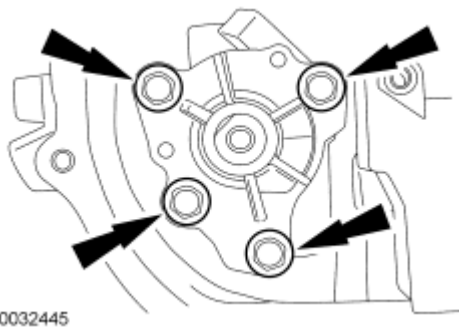

Fig. 352: Locating Oil Pump Assembly & Bolts
Courtesy of FORD MOTOR CO.

77. Remove the 3 bolts and the intermediate shaft bearing bracket.

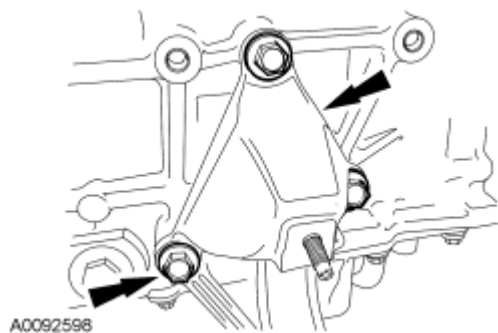

Fig. 353: Locating Intermediate Shaft Bearing Bracket And Bolts
Courtesy of FORD MOTOR CO.

2.3L engines

78. Make sure the Crankshaft **TDC** Timing Peg is still installed and the engine is still at Top Dead Center (TDC).
 - Rotate the crankshaft slowly clockwise until the crankshaft balance weight is up against the Crankshaft **TDC** Timing Peg.

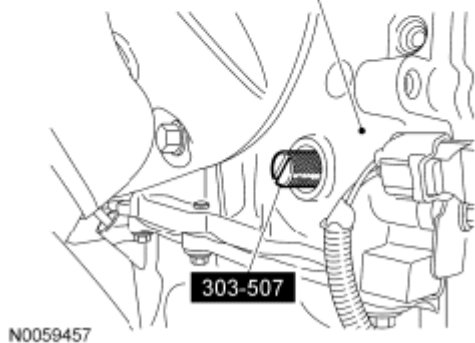
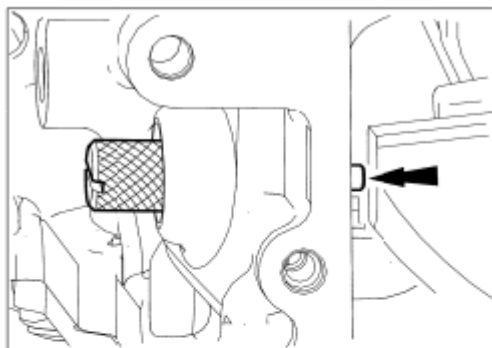

Fig. 354: Installing Crankshaft TDC Timing Peg

79. Mark the balancer unit and shafts on the top for reference that the balancer unit is at **TDC** .

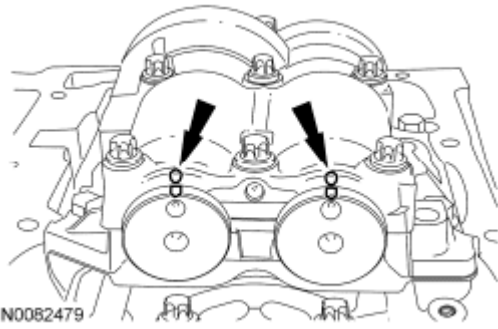

Fig. 355: Locating Balancer Unit And Shafts Reference Mark

80. **NOTE:** Due to the precision interior construction of the balancer unit, it should not be disassembled.

Remove the 4 bolts and the balancer unit.

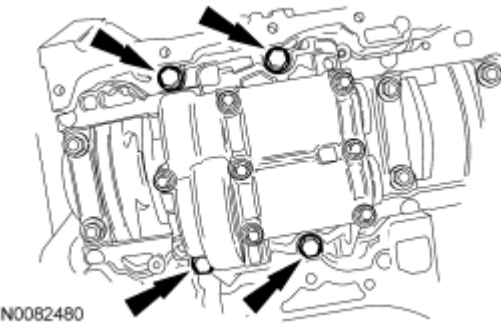

Fig. 356: Locating Balancer Unit Bolts

All vehicles

81. Remove the Crankshaft TDC Timing Peg.

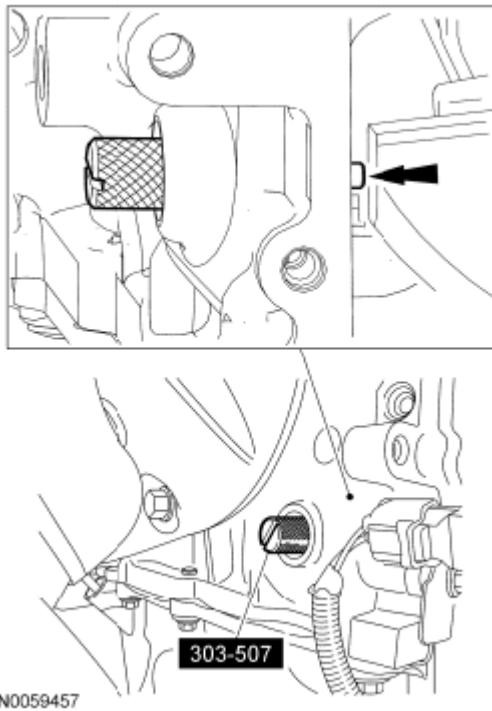

Fig. 357: Installing Crankshaft TDC Timing Peg

82. Before removing the pistons, inspect the top of the cylinder bores. If necessary, remove the ridge or carbon deposits from each cylinder using an abrasive pad or equivalent, following manufacturer's instructions.

NOTE: Clearly mark the connecting rods, connecting rod caps and connecting rod bearings in numerical order for correct orientation for reassembly.

83.

Remove the connecting rod cap bolts and cap.

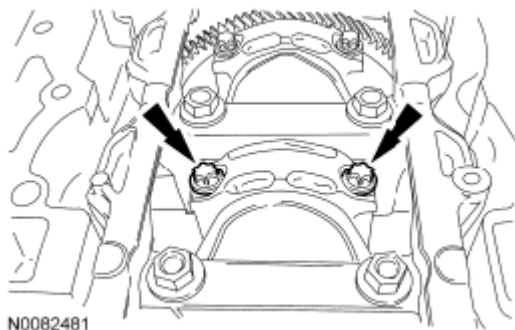

Fig. 358: Locating Connecting Rod Cap Bolts

NOTE: Do not scratch the cylinder walls or crankshaft journals with the connecting rod.

84.

Using the Connecting Rod Installer, remove the piston/rod assembly from the engine block.

- Repeat the previous 2 steps until all the piston/rod assemblies are removed from the engine block.

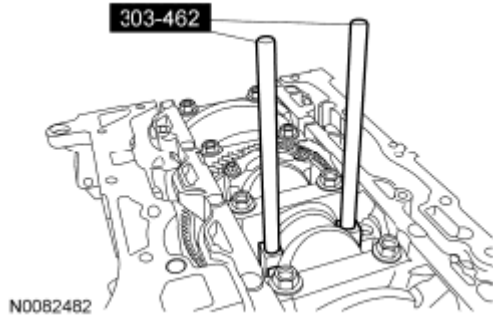

Fig. 359: Identifying Connecting Rod Installer

85. Remove the bolts in the sequence shown.

- Remove the main bearing beam.
- Discard the bolts.

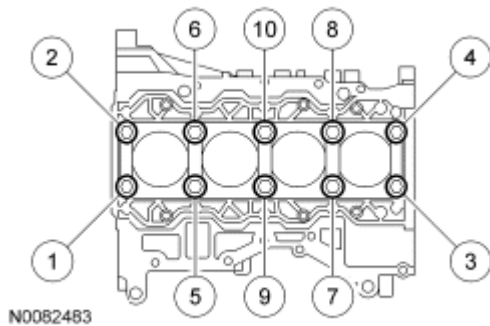

Fig. 360: Identifying Crankshaft Cap Bolts Removing Sequence

86. Remove the crankshaft from the engine block.

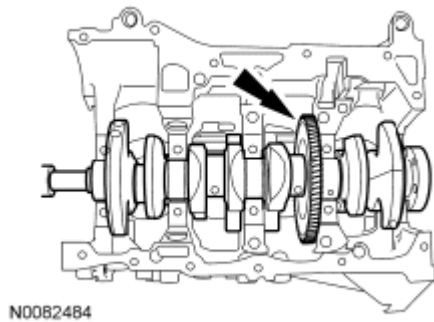
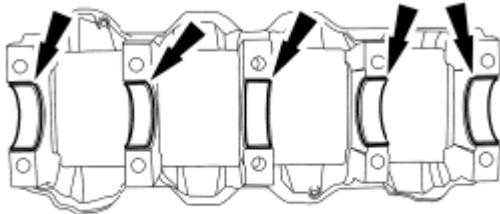

Fig. 361: Locating Crankshaft

87. **NOTE:** If the main bearings are being reused, mark them in order for correct orientation and reassembly.

Remove the main bearings from the main bearing beam.



N0082485

Fig. 362: Locating Main Bearings

88. **NOTE:** If the main bearings are being reused, mark them in order for correct orientation and reassembly.

NOTE: The center bulkhead has the thrust bearing.

Remove the main bearings from the cylinder block.

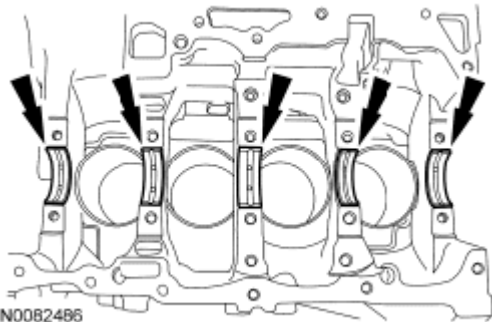

N0082486

Fig. 363: Locating Main Bearings

89. **NOTE:** If the oil squirters are being reused, mark them in order for correct location during reassembly.

NOTE: The front bulkhead does not have an oil squirter.

Remove the 4 oil squirters.

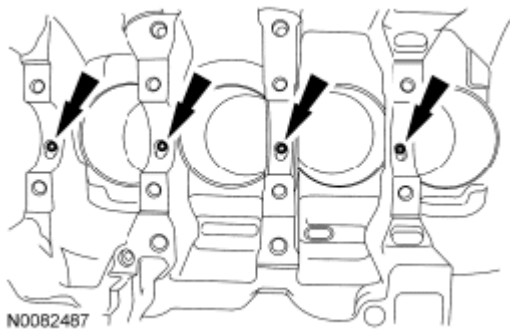



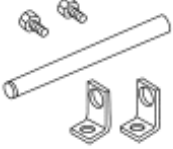

Fig. 364: Locating Oil Squirters

90. Inspect the cylinder block, main bearing beam, pistons and connecting rods. For additional information, refer to **ENGINE SYSTEM - GENERAL INFORMATION** .

DISASSEMBLY AND ASSEMBLY OF SUBASSEMBLIES



CYLINDER HEAD

Special Tools

Illustration	Tool Name	Tool Number
 ST1187-A	Impact Hammer	307-005 (T59L-100-B)
 ST1909-A	Valve Spring Compressor Set	303-300 (T87C-6565-A)
 ST1904-A	Valve Stem Seal Remover	303-468 (T94P-6510-AH)
 ST1906-A	Valve Stem Seal Replacer	303-470 (T94P-6510-CH)

2007 Ford Focus S

2007 ENGINE Engine - 2.0L and 2.3L - Focus

 <p>ST1907-A</p>	Valve Spring Compressor	303-350 (T89P-6565-A)
 <p>ST1902-A</p>	Compressor, Valve Spring	303-472 (T94P-6565-AH)

Material

Item	Specification
Motorcraft SAE 5W-20 Premium Synthetic Blend Motor Oil XO-5W20-QSP (US); Motorcraft SAE 5W-20 Super Premium Motor Oil CXO-5W20-LSP12 (Canada); or equivalent	WSS-M2C930-A
Multi-Purpose Grease XG-4 and/or XL-5	ESB-M1C93-B

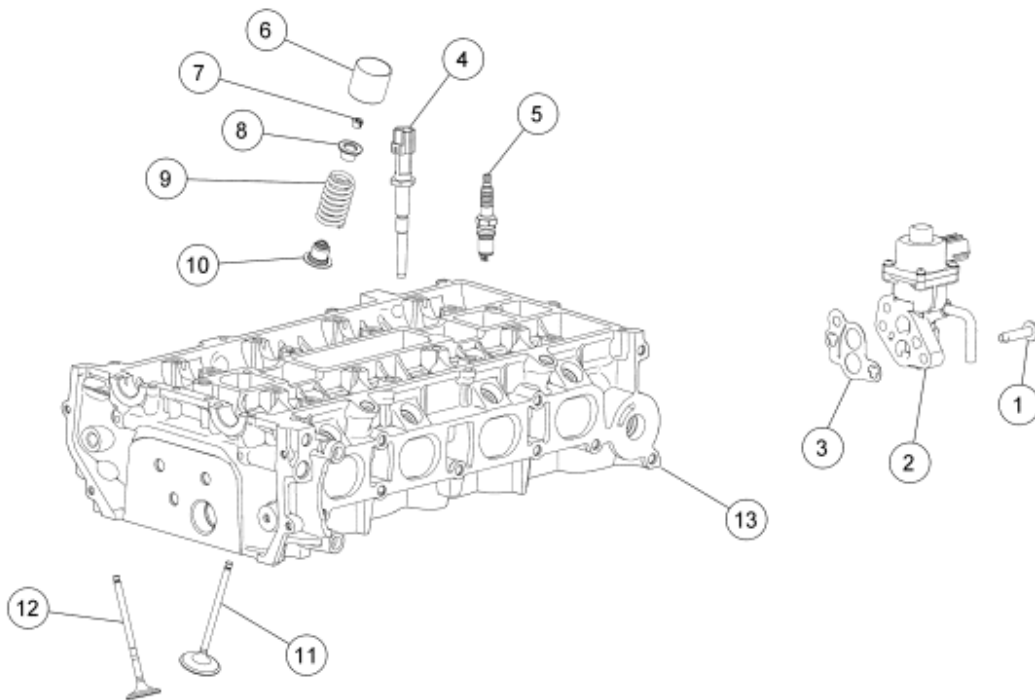

N0039167

Fig. 365: Identifying Cylinder Head Components
 Courtesy of FORD MOTOR CO.

2007 Ford Focus S

2007 ENGINE Engine - 2.0L and 2.3L - Focus

Item	Part Number	Description
1	W500225	Exhaust gas recirculation (EGR) valve bolts (2 required)
2	9D475	EGR valve
3	9D476	EGR valve gasket
4	6G004	Cylinder head temperature (CHT) sensor
5	12405	Spark plug (4 required)
6	6500	Valve tappet (16 required)
7	6518	Valve collet (16 required)
8	6514	Valve spring retainer (16 required)
9	6513	Valve spring (16 required)
10	6517	Valve seal (16 required)
11	6505	Intake valve (8 required)
12	6507	Exhaust valve (8 required)
13	6049	Cylinder head

DISASSEMBLY

NOTE: One lifting eye shown, other lifting eye similar.

1. Remove the bolts and the 2 lifting eyes.

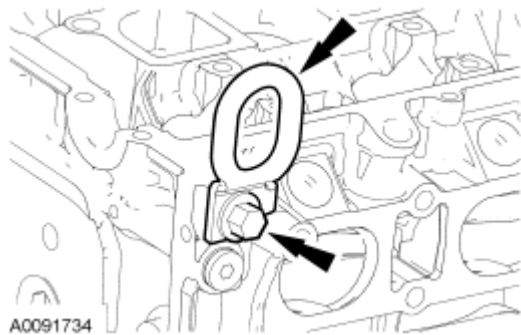

Fig. 366: Locating Lifting Eyes And Bolts
Courtesy of FORD MOTOR CO.

2. Remove and discard the cylinder head temperature (CHT) sensor.

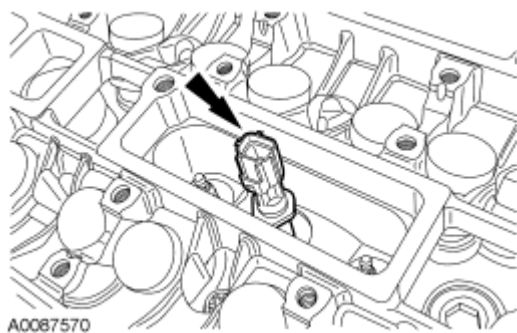

Fig. 367: Locating Cylinder Head Temperature Sensor
Courtesy of FORD MOTOR CO.

3. Remove the bolts and the exhaust gas recirculation (EGR) valve.

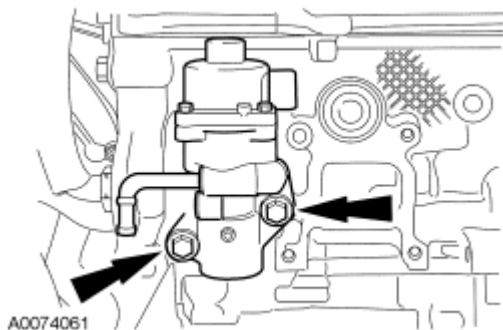

Fig. 368: Locating Exhaust Gas Recirculation Valve And Bolts
Courtesy of FORD MOTOR CO.

4. Remove the EGR tube.

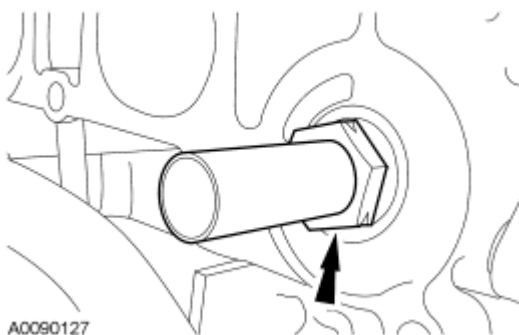

Fig. 369: Locating Exhaust Gas Recirculation Tube
Courtesy of FORD MOTOR CO.

5. Remove the spark plugs.

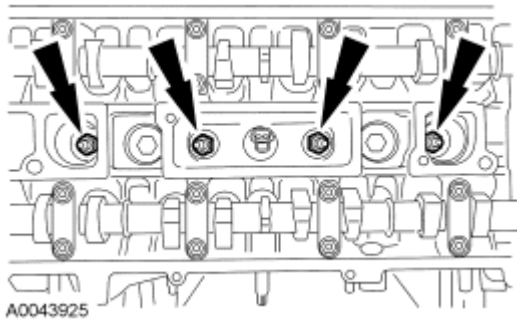

Fig. 370: Locating Spark Plugs
Courtesy of FORD MOTOR CO.

CAUTION: Note the location of the tappets prior to removal.

6. Remove the 16 tappets.

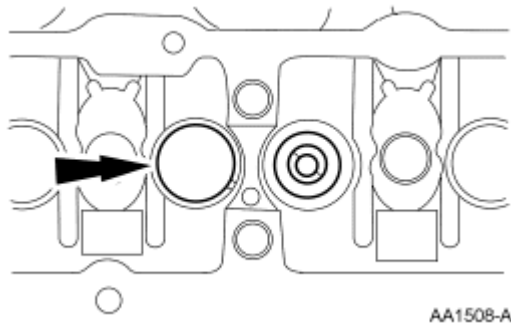

Fig. 371: Locating Valve Tappet
Courtesy of FORD MOTOR CO.

7. Using the special tools, compress the valve spring and remove the valve spring retainer keys, the valve spring retainers and the valve springs.

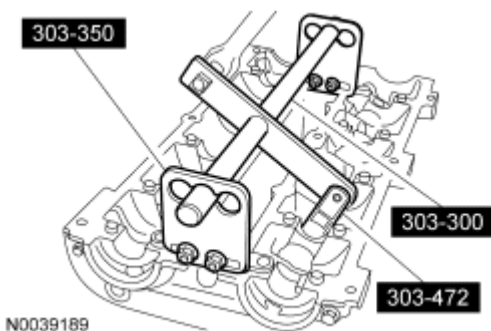

Fig. 372: Compressing Valve Spring Using Special Tools (303-300, 303-350, 303-472)
Courtesy of FORD MOTOR CO.

8. Inspect the valve spring, valve spring retainer and valve spring retainer key. For additional information, refer to **ENGINE SYSTEM - GENERAL INFORMATION** article.

CAUTION: Note the location of the valves if they are to be reused.

NOTE: Mark each valve if the original valves are to be used.

9. Remove the valves.

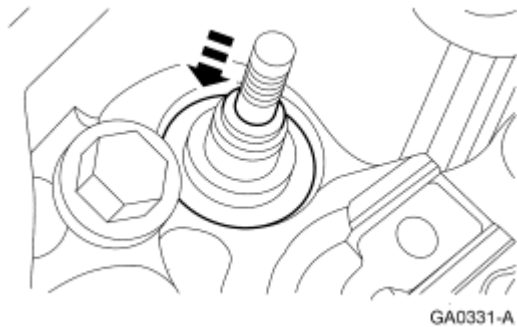

Fig. 373: Removing Valve
Courtesy of FORD MOTOR CO.

10. Using the special tools, remove and discard the valve seals.

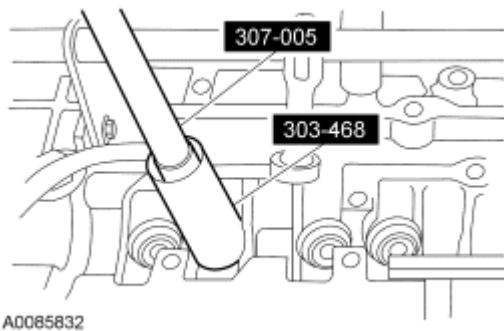

Fig. 374: Identifying Special Tools (307-005, 303-468)
Courtesy of FORD MOTOR CO.

11. Inspect the valves. For additional information, refer to **ENGINE SYSTEM - GENERAL INFORMATION** article. Install new parts, as necessary.

ASSEMBLY

NOTE: If installing the original valves, make sure the valves are installed in the same position from which they were removed. Coat the valve stems with motor oil.

1. Install the valves.

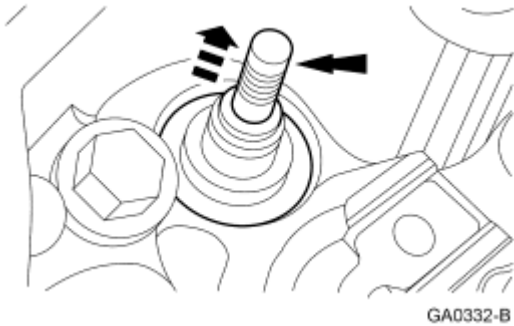

Fig. 375: Installing Valve
Courtesy of FORD MOTOR CO.

NOTE: Use the protector provided with the replacement kit to prevent damage to the valve seals.

2. Lubricate the valve stems and guides with clean engine oil and, using the special tool, install the valve seals onto the cylinder head valve guides.

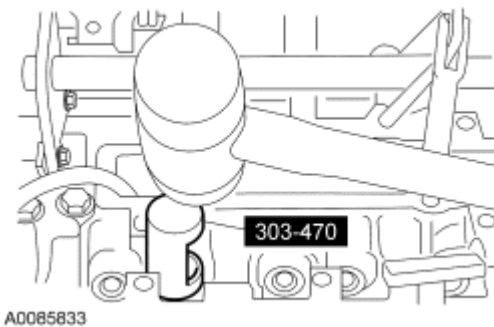

Fig. 376: Identifying Special Tool (303-470)
Courtesy of FORD MOTOR CO.

3. Place the valve spring in position over the valve and install the valve spring retainer.
4. Using the special tools, compress the valve spring and install the valve spring retainer keys.

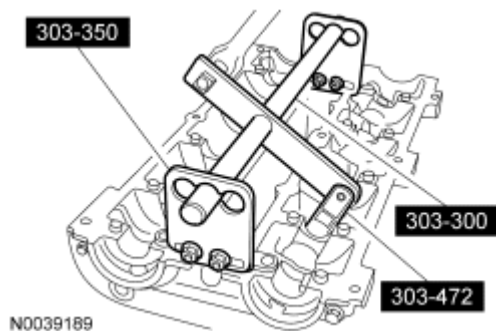

Fig. 377: Compressing Valve Spring Using Special Tools (303-300, 303-350, 303-472)
Courtesy of FORD MOTOR CO.

NOTE: Be sure to install the tappets in the same location from which they were removed.

5. Install the 16 tappets.

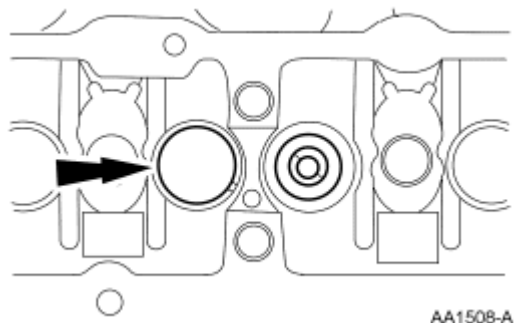

Fig. 378: Locating Valve Tappet
Courtesy of FORD MOTOR CO.

6. Install a new CHT sensor.
 - Tighten to 12 Nm (9 lb-ft).

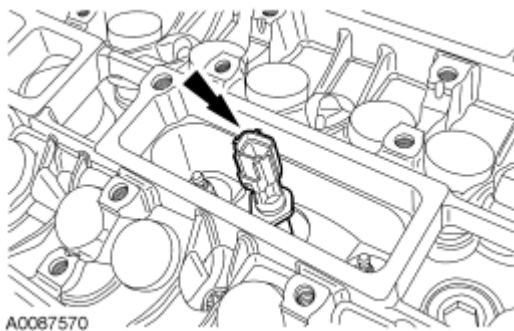

Fig. 379: Locating Cylinder Head Temperature Sensor
Courtesy of FORD MOTOR CO.

7. Install the spark plugs.
 - Tighten to 12 Nm (9 lb-ft).

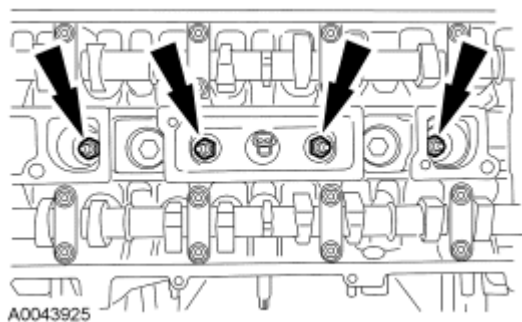

Fig. 380: Locating Spark Plugs
 Courtesy of FORD MOTOR CO.

8. Install the EGR tube.
 - Tighten to 55 Nm (41 lb-ft).

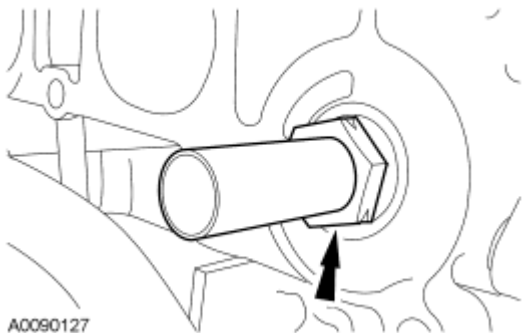

Fig. 381: Locating Exhaust Gas Recirculation Tube
 Courtesy of FORD MOTOR CO.

9. Install the EGR valve, gasket and 2 bolts.
 - Tighten to 20 Nm (15 lb-ft).

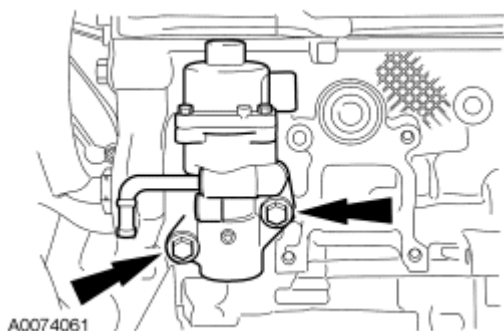

Fig. 382: Locating Exhaust Gas Recirculation Valve And Bolts
 Courtesy of FORD MOTOR CO.

NOTE: One lifting eye shown, other lifting eye similar.

10. Install the 2 lifting eyes and the bolts.
 - Tighten to 45 Nm (33 lb-ft).

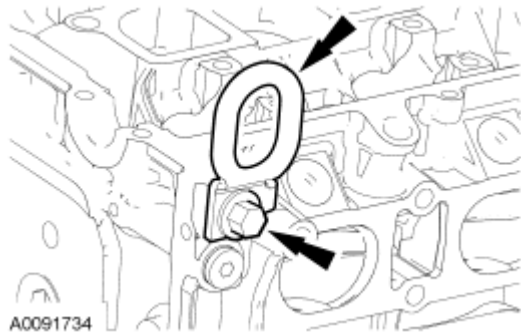

Fig. 383: Locating Lifting Eyes And Bolts
 Courtesy of FORD MOTOR CO.

ASSEMBLY

ENGINE BLOCK

For engine block, crankshaft and piston assembly installation procedures, refer to [ENGINE BLOCK - 2.3L](#) .



ENGINE (EXCEPT BLOCK)

Special Tools

Illustration	Tool Name	Tool Number
<p>ST1341-A</p>	Heavy Duty Floor Crane	014-00071 or equivalent
<p>ST1602-A</p>	Spreader Bar	303-D089 (D93P-6001-A3) or equivalent
<p>ST2645-A</p>	Alignment Plate, Camshaft	303-465 (T94P-6256-CH)
	Timing Peg, Crankshaft	303-507

2007 Ford Focus S

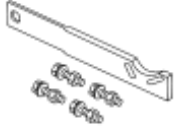
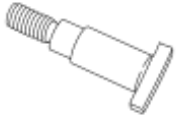
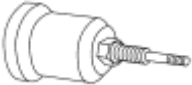
2007 ENGINE Engine - 2.0L and 2.3L - Focus

 <p>ST2638-A</p>		
 <p>ST2647-A</p>	<p>Holding Fixture, Drive Pinion Flange</p>	<p>205-126 (T78P-4851-A)</p>
 <p>ST2639-A</p>	<p>Adapter for 205-126</p>	<p>(205-072-02)</p>
 <p>ST1917-A</p>	<p>Installer, Front Oil Seal</p>	<p>303-096 (T74P-6150-A)</p>
 <p>ST1506-A</p>	<p>Installer, Crankshaft Rear Main Oil Seal</p>	<p>303-328 (T88P-6701-B1)</p>
 <p>ST1751-A</p>	<p>Aligner, Clutch Disc</p>	<p>308-006 (T71P-7137-H)</p>

Material

Item	Specification
<p>Motorcraft SAE 5W-20 Premium Synthetic Blend Motor Oil XO-5W20-QSP (US); Motorcraft SAE 5W-20 Super Premium Motor Oil CXO-5W20-LSP12 (Canada); or equivalent</p>	<p>WSS-M2C930-A</p>
<p>Motorcraft Metal Surface Cleaner ZC-21</p>	<p>WSE-M5B392-A</p>
<p>Silicone Gasket and Sealant TA-30</p>	<p>WSE-M4G323-A4</p>

2007 Ford Focus S

2007 ENGINE Engine - 2.0L and 2.3L - Focus

Silicone Gasket Remover ZC-30	-
Motorcraft Metal Surface Prep ZC-31	-
Silicone Brake Caliper Grease and Dielectric Compound XG-3-A	ESE-M1C171-A
Motorcraft Premium Gold Engine Coolant with Bittering Agent (US only) VC-7-B (US); CVC-7-A (Canada); or equivalent (yellow color)	WSS-M97B51-A1
High-Temp 4x4 Front Axle and Wheel Bearing Grease E8TZ-19590-A	ESA-M1C198-A

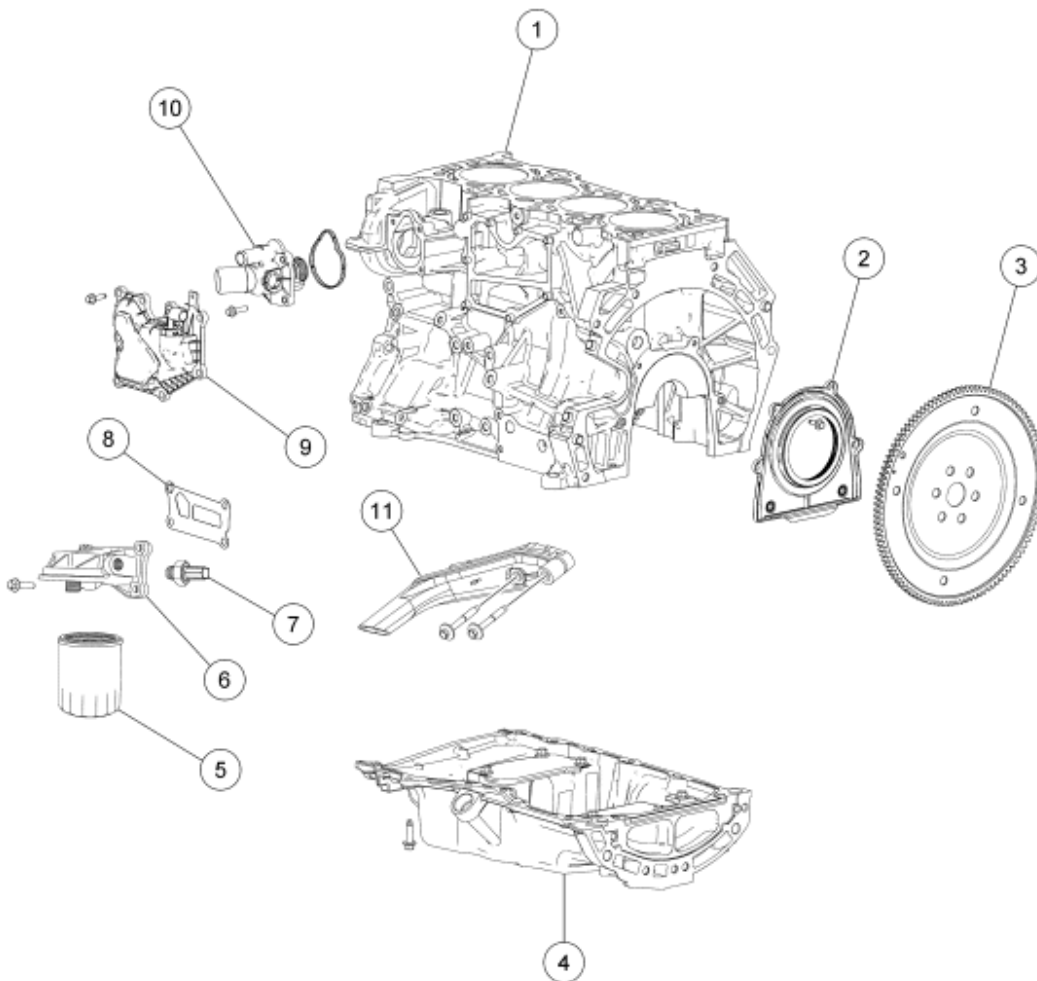

A0090482

2007 Ford Focus S

2007 ENGINE Engine - 2.0L and 2.3L - Focus

Fig. 384: Lower Engine Block (View 1)

Courtesy of FORD MOTOR CO.

Item	Part Number	Description
1	6010	Cylinder block
2	6K318	Crankshaft rear oil seal and retainer
3	6477	Flywheel
4	6675	Oil pan
5	6714	Oil filter
6	6884	Oil filter adapter
7	9278	Oil pressure sensor
8	6A636	Oil filter adapter gasket
9	6A785	Crankcase vent oil separator
10	8575	Thermostat assembly
11	6622	Oil pump screen and pickup tube

2007 Ford Focus S

2007 ENGINE Engine - 2.0L and 2.3L - Focus

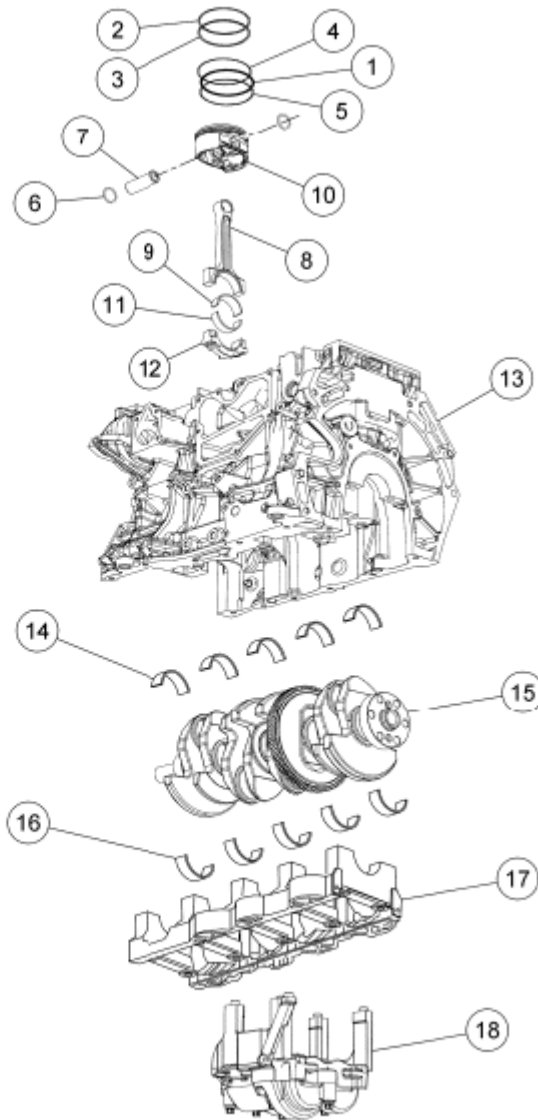

N0105927

Fig. 385: Identifying Lower Engine Block Components (View 2)

ITEM DESCRIPTION

Item	Part Number	Description
1	6161	Piston oil control spacer (4 required)
2	6150	Piston compression upper ring (4 required)
3	6152	Piston compression lower ring (4 required)
4	6159	Piston oil control upper segment ring (4 required)
5	6159	Piston oil control lower segment ring (4 required)

2007 Ford Focus S

2007 ENGINE Engine - 2.0L and 2.3L - Focus

6	6140	Piston pin retainer (8 required)
7	6135	Piston pin (4 required)
8	6200	Connecting rod (4 required)
9	6211	Connecting rod upper bearing (4 required)
10	6110	Piston (4 required)
11	6211	Connecting rod lower bearing (4 required)
12	6210	Connecting rod cap (4 required)
13	6010	Cylinder block
14	6333	Cylinder block crankshaft main bearing (5 required)
15	6303	Crankshaft
16	6333	Crankshaft main bearing beam bearing (5 required)
17	6F098	Main bearing beam
18	6K360	Balance shaft assembly

2007 Ford Focus S

2007 ENGINE Engine - 2.0L and 2.3L - Focus

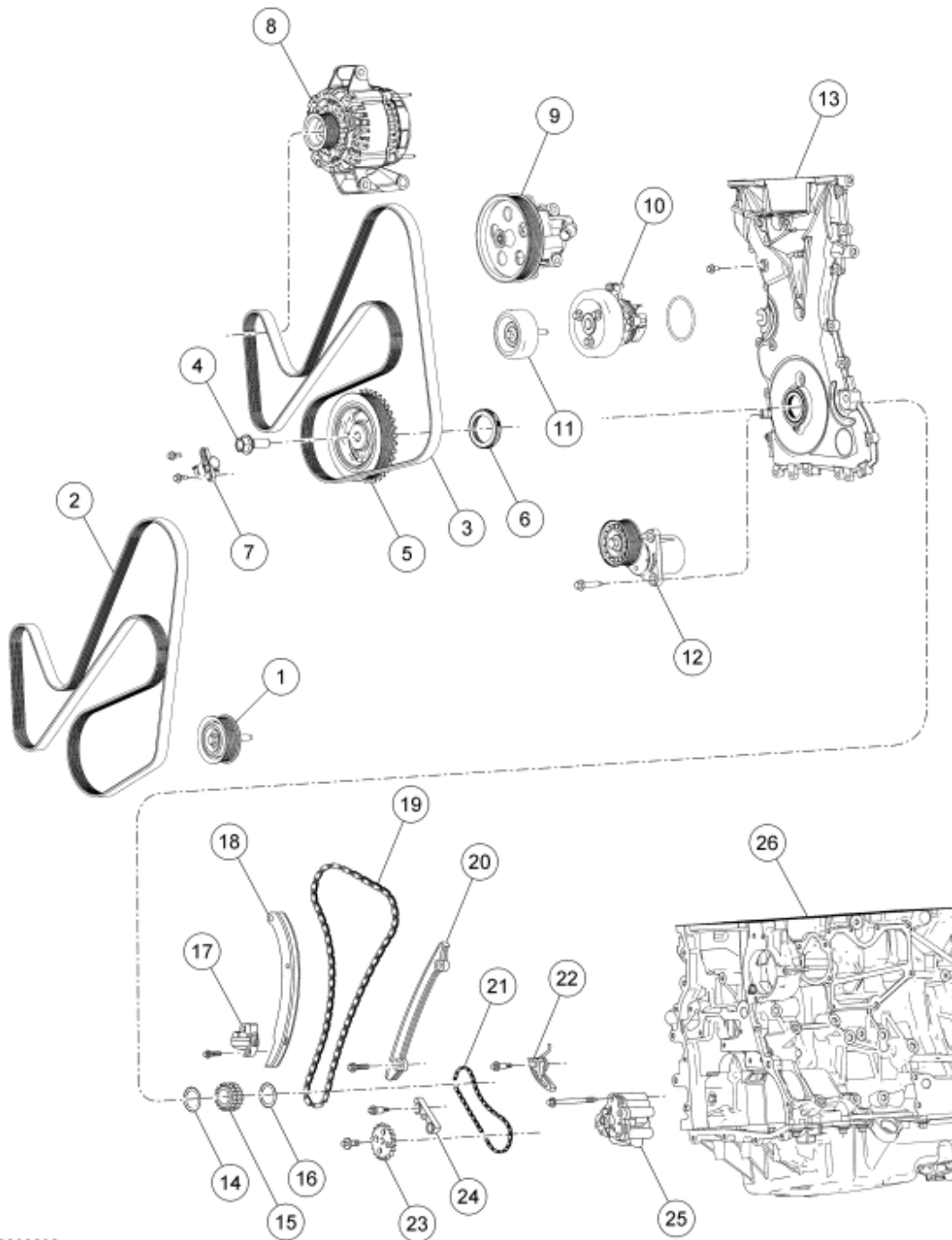

A0093092

Fig. 386: Front Engine Block
 Courtesy of FORD MOTOR CO.

Item	Part Number	Description
1	19A216	Drive belt pulley idler (without A/C)
2	6C301	Accessory drive belt (without A/C)
3	6C301	Accessory drive belt (with A/C)

2007 Ford Focus S

2007 ENGINE Engine - 2.0L and 2.3L - Focus

4	6A340	Crankshaft pulley bolt
5	6316	Crankshaft damper
6	6700	Crankshaft front seal
7	6C315	Crankshaft position (CKP) sensor
8	10300	Generator
9	3A696	Power steering pump
10	8501	Coolant pump and pulley
11	19A216	Drive belt pulley idler (with A/C)
12	6A228	Drive belt tensioner
13	6019	Engine front cover
14	6378	Diamond washer
15	6306	Crankshaft sprocket
16	6378	Diamond washer
17	6K254	Timing chain tensioner
18	6K255	Timing chain tensioner arm
19	6268	Timing chain
20	6K297	Timing chain guide
21	6A895	Oil pump chain
22	6C271	Oil pump chain tensioner
23	6652	Oil pump drive gear
24	6M256	Oil pump chain guide (early build)
25	6600	Oil pump
26	6010	Cylinder block

2007 Ford Focus S

2007 ENGINE Engine - 2.0L and 2.3L - Focus

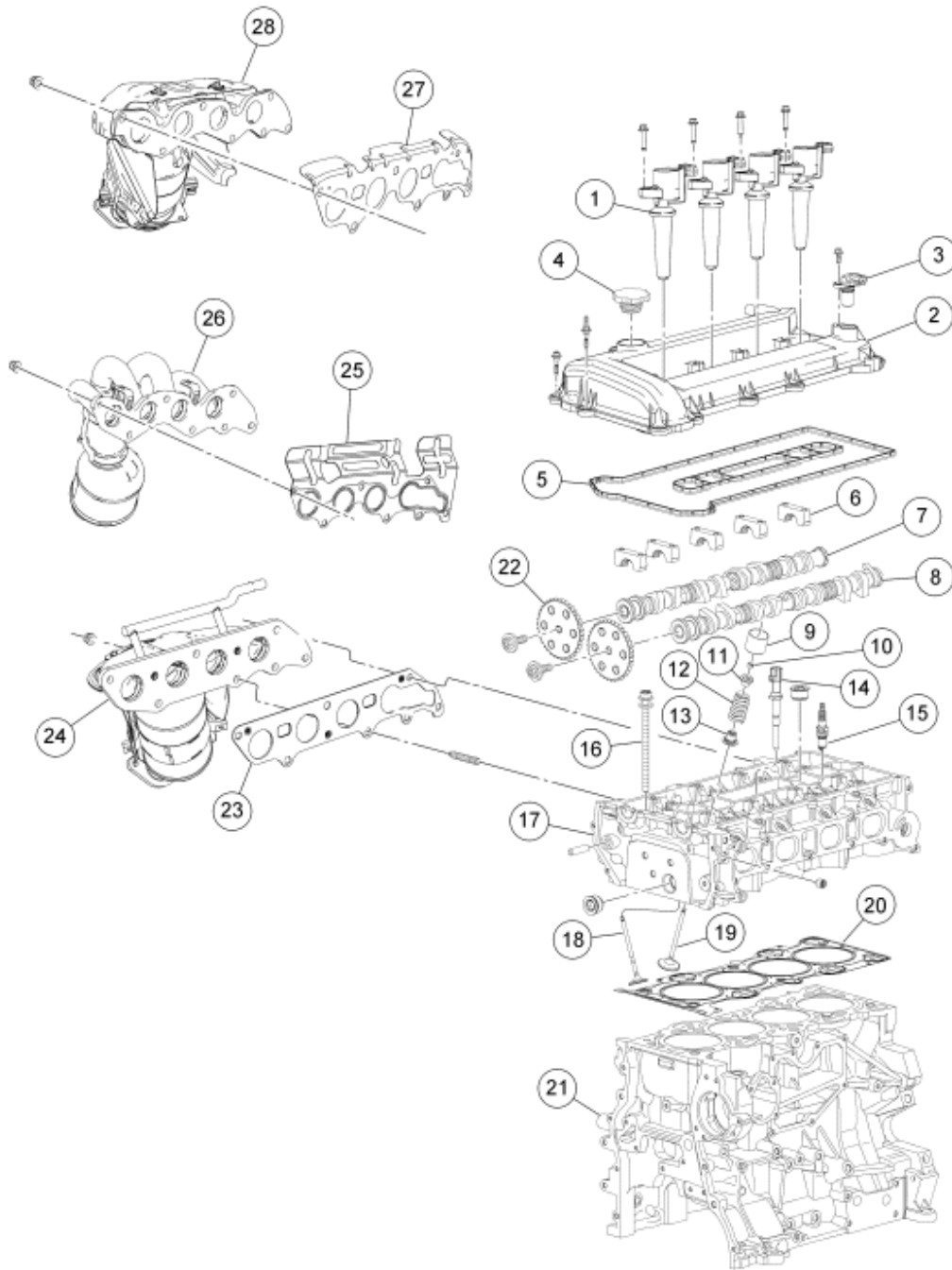

N0042248

Fig. 387: Cylinder Head

Courtesy of FORD MOTOR CO.

Item	Part Number	Description
1	12A366	Coil-on-plug assembly
2	6M293	Valve cover
3	12K073	Camshaft position (CMP) sensor

2007 Ford Focus S

2007 ENGINE Engine - 2.0L and 2.3L - Focus

4	6766	Oil filler cap
5	6M293	Valve cover gasket
6	6A284	Camshaft bearing caps
7	6A272	Camshaft (exhaust)
8	6A271	Camshaft (intake)
9	6500	Valve tappet (16 required)
10	6518	Valve spring retainer key (16 required)
11	6514	Valve spring retainer (16 required)
12	6513	Valve spring (16 required)
13	6A517	Valve stem seal (16 required)
14	6G004	Cylinder head temperature (CHT) sensor
15	12405	Spark plug (4 required)
16	6065	Cylinder head bolt (10 required)
17	6049	Cylinder head
18	6505	Exhaust valve (8 required)
19	6507	Intake valve (8 required)
20	6051	Head gasket
21	6010	Cylinder block
22	6C251	Camshaft sprocket (2 required)
23	9448	Catalytic converter gasket (with secondary air injection (AIR))
24	5E211	2.0L catalytic converter (with AIR)
25	9448	Catalytic converter gasket (without AIR)
26	5E211	2.3L catalytic converter
27	9448	2.0L catalytic converter gasket (without AIR)
28	5G232	2.0L catalytic converter

2007 Ford Focus S

2007 ENGINE Engine - 2.0L and 2.3L - Focus

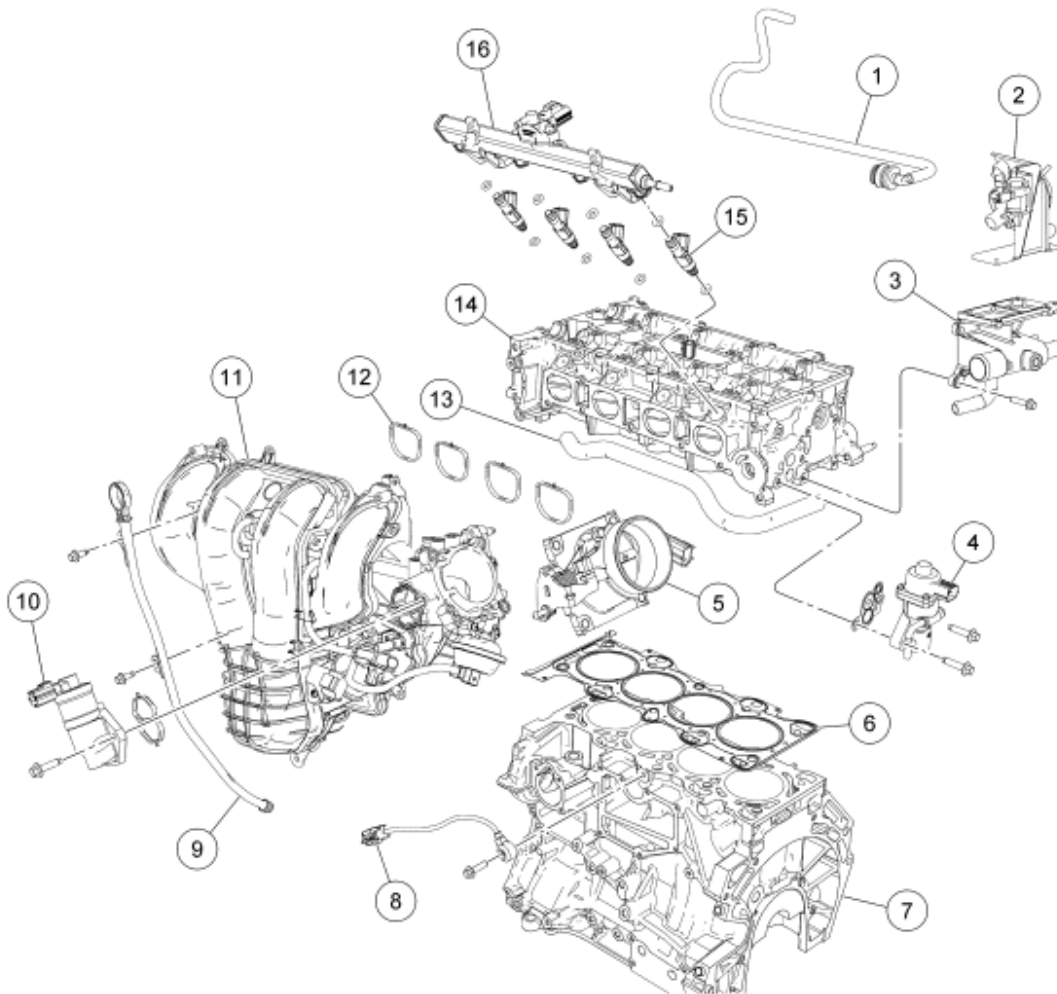

A0090485

Fig. 388: Intake Manifold
Courtesy of FORD MOTOR CO.

Item	Part Number	Description
1	9288	Fuel supply tube
2	9F491	AIR valve and bracket (if equipped)
3	8K556	Coolant outlet
4	9D475	Exhaust gas recirculation (EGR) valve
5	9E926	Throttle body assembly
6	6051	Cylinder head gasket
7	6010	Cylinder block
8	12A699	Knock sensor
9	6754	Oil level indicator tube
10	9F715	Idle air control (IAC) valve assembly

2007 Ford Focus S

2007 ENGINE Engine - 2.0L and 2.3L - Focus

11	9424	Intake manifold
12	9439	Intake manifold gasket
13	8A582	Coolant hose
14	6049	Cylinder head
15	9F593	Fuel injector (4 required)
16	9H487	Fuel rail

CAUTION: Do not loosen or remove the crankshaft pulley bolt without first installing the special tools as instructed in this procedure. The crankshaft pulley and the crankshaft timing sprocket are not keyed to the crankshaft. The crankshaft, the crankshaft sprocket and the pulley are fitted together by friction, using diamond washers between the flange faces on each part. For that reason, the crankshaft sprocket is also unfastened if the pulley bolt is loosened. Before any repair requiring loosening or removal of the crankshaft pulley bolt, the crankshaft and camshafts must be locked in place by the special service tools, otherwise severe engine damage can occur.

CAUTION: During engine repair procedures, cleanliness is extremely important. Any foreign material (including any material created while cleaning gasket surfaces) that enters the oil passages, coolant passages or the oil pan, can cause engine failure.

NOTE: Early build engines are equipped with an oil pump drive chain guide. Late build engines do not have an oil pump drive chain guide. Also, late build engines use an updated design for the oil pump drive chain and tensioner. Therefore, the oil pump drive components are not interchangeable between early build and late build engines.

All engines

NOTE: If the oil squirters are being reused, they must be installed in the same location as marked during disassembly.

- 1.

NOTE: The front bulkhead does not have an oil squirter.

Install the 4 oil squirters.

- Tighten to 4 Nm (35 lb-in).

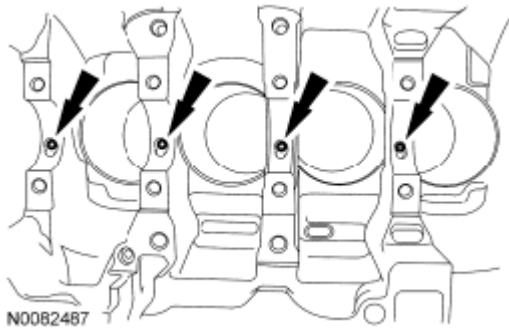

Fig. 389: Locating Oil Squirters

2. Measure each of the crankshaft main bearing journal diameters in at least 2 directions and record the smallest diameter for each journal.

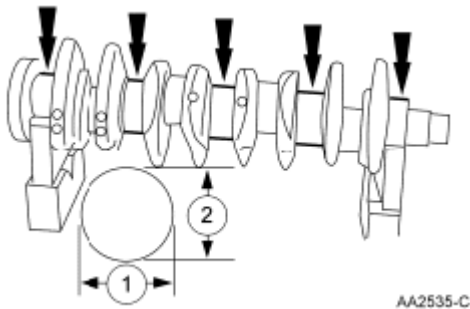

Fig. 390: Identifying Measuring Directions Of Crankshaft Main Bearing Journal Diameter

3. Position the main bearing beam in the engine block with the main bearing beam mounted flush with the rear face of the engine block.

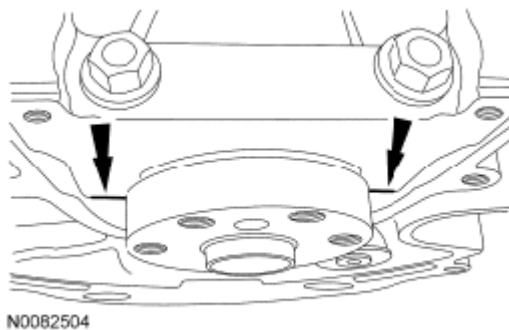

Fig. 391: Locating Main Bearing Beam

4. Using the original main bearing beam bolts, install and tighten the 10 main bearing beam bolts.
 - Tighten the bolts in the sequence shown in 3 stages.
 - Stage 1: Tighten to 5 Nm (44 lb-in).

- Stage 2: Tighten to 25 Nm (18 lb-ft).
- Stage 3: Tighten an additional 90 degrees.

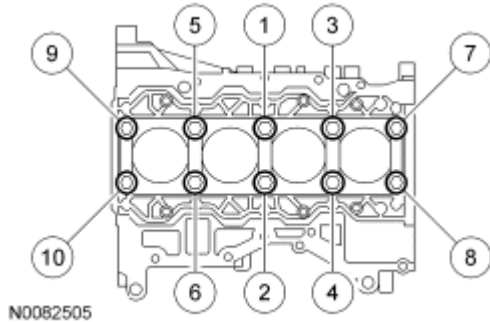

Fig. 392: Identifying Main Bearing Beam Bolts Tightening Sequence

5. Measure each crankshaft block main bearing bore diameter.
 - Remove the bolts and the main bearing beam.
 - Discard the main bearing beam bolts.

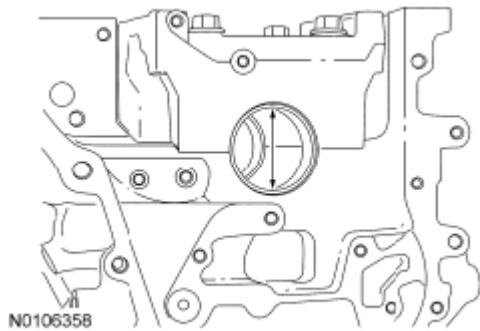

Fig. 393: Identifying Crankshaft Block Main Bearing Bore Diameter

6. Using the chart, select the crankshaft main bearings.

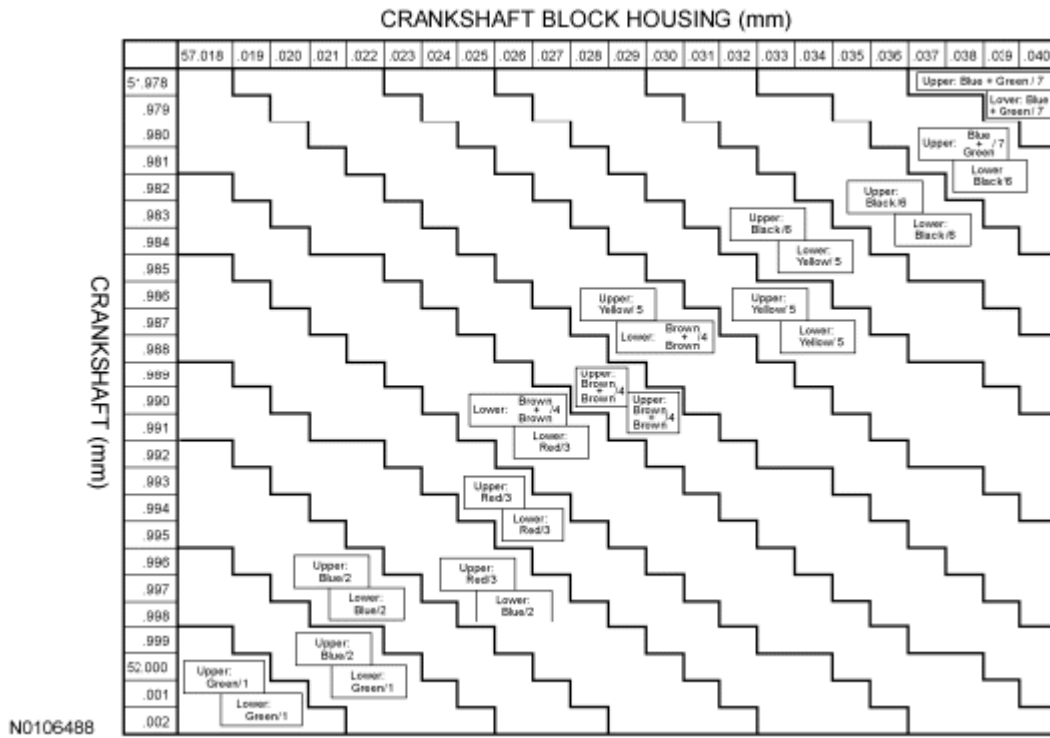

Fig. 394: Crankshaft Main Bearings Chart

NOTE: The rod cap installation must keep the same orientation as marked during disassembly or engine damage may occur.

7.

Using the original connecting rod cap bolts, install the connecting caps and bolts.

- Tighten the bolts in 2 stages.
- Stage 1: Tighten to 29 Nm (21 lb-ft).
- Stage 2: Tighten an additional 90 degrees.

8. Measure the connecting rod large end bore in 2 directions. Record the smallest measurement for each connecting rod.

- Remove the bolts and the connecting rod cap.
- Discard the connecting rod cap bolts.

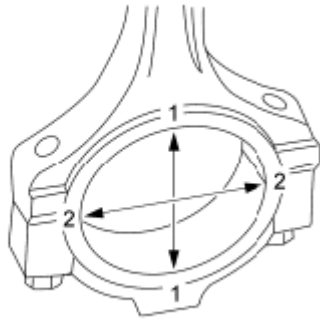

A0026938

Fig. 395: Identifying Connecting Rod Large End Bore Measuring Directions

9. Measure each of the crankshaft connecting rod bearing journal diameters in at least 2 directions. Record the smallest measurement for each connecting rod journal.

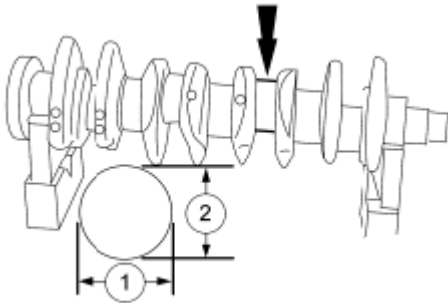

N0082805

Fig. 396: Identifying Measuring Directions Of Crankshaft Connecting Rod Bearing Journal Diameters

10. Using the chart, select the correct connecting rod bearings for each crankshaft connecting rod journal.

2007 Ford Focus S

2007 ENGINE Engine - 2.0L and 2.3L - Focus

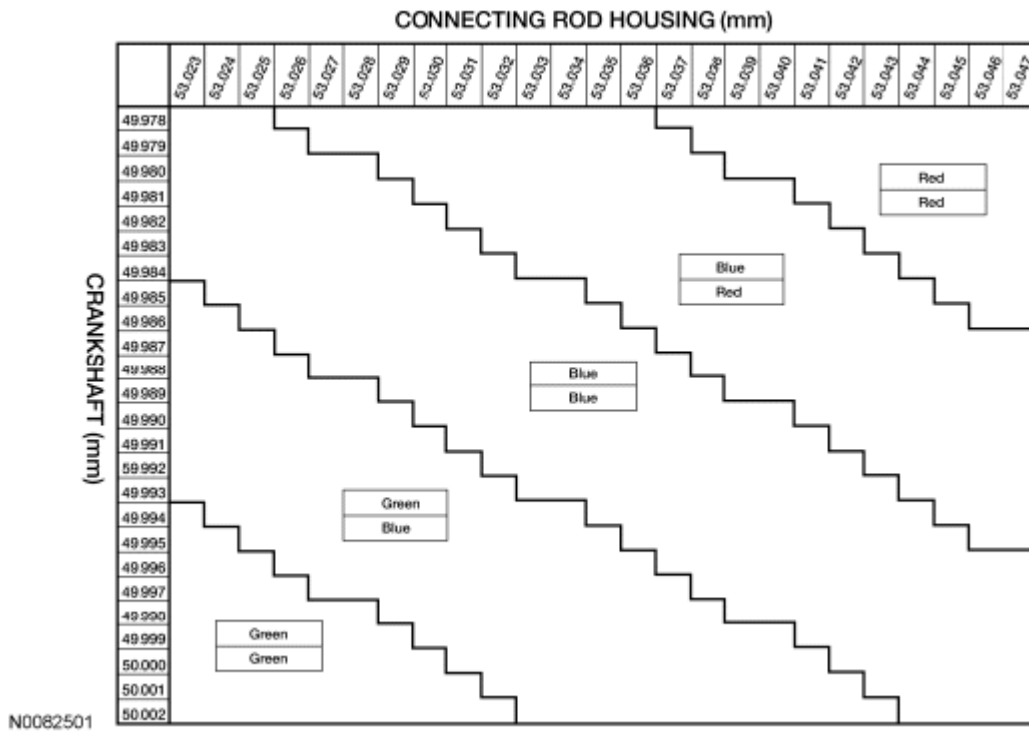

Fig. 397: Connecting Rod Bearings Chart

11. **NOTE:** Before assembling the cylinder block, all sealing surfaces must be free of chips, dirt, paint and foreign material. Also, make sure the coolant and oil passages are clear.
- NOTE:** If reusing the crankshaft main bearings, install them in their original positions and orientation as noted during disassembly.
- NOTE:** The center bulkhead is the thrust bearing.

Lubricate the upper crankshaft main bearings with clean engine oil and install the 5 crankshaft main bearings in the cylinder block.

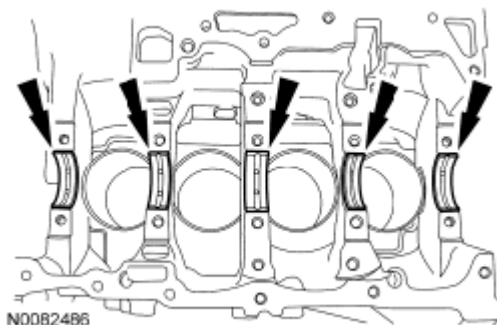
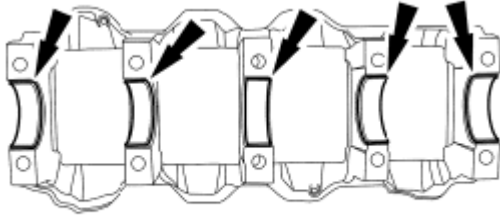

Fig. 398: Locating Upper Crankshaft Main Bearings

NOTE: If reusing the crankshaft main bearings, install them in their original positions and orientation as noted during disassembly.

12.

Lubricate the crankshaft main bearings with clean engine oil and install the 5 crankshaft main bearings in the main bearing beam.



N0082485

Fig. 399: Locating Crankshaft Main Bearings

13. Lubricate journals on the crankshaft with clean engine oil.
14. Position the crankshaft in the cylinder block.

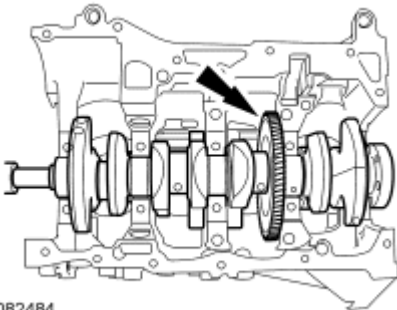

N0082484

Fig. 400: Locating Crankshaft

15. Lubricate the 10 main bearing beam side fit surfaces (front 2 shown) with clean engine oil.

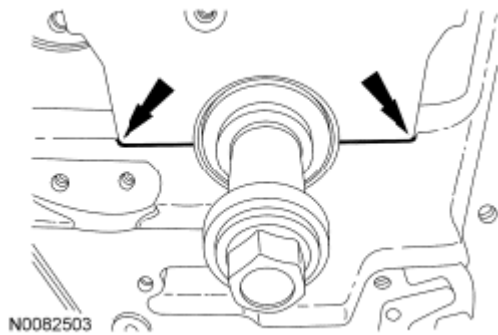

Fig. 401: Locating Main Bearing Beam Side Fit Surfaces

16. Lubricate the crankshaft bearing journals on the main bearing beam with clean engine oil. Then position the main bearing beam in the engine block with the main bearing beam mounted flush with the rear face of the engine block.

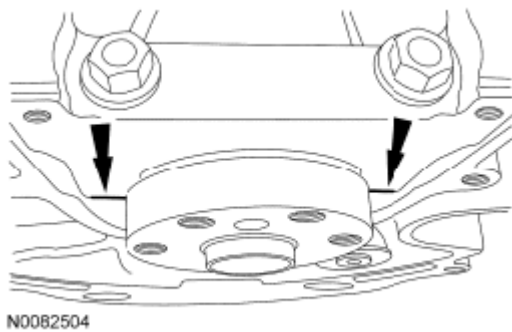

Fig. 402: Locating Main Bearing Beam

17. **NOTE:** Lubricate the main bearing beam bolts threads and under the bolt heads with clean engine oil.
- NOTE:** Position the crankshaft to the rear of the cylinder block, then position the crankshaft to the front of the cylinder block before tightening the main bearing beam bolts.

Install and tighten the 10 new main bearing beam bolts.

- Tighten the bolts in the sequence shown in 3 stages.
- Stage 1: Tighten to 5 Nm (44 lb-in).
- Stage 2: Tighten to 25 Nm (18 lb-ft).
- Stage 3: Tighten an additional 90 degrees.

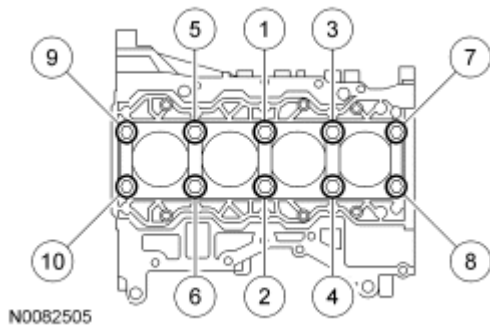

Fig. 403: Identifying Main Bearing Beam Bolts Tightening Sequence

18. Using the Dial Indicator Gauge with Holding Fixture, measure crankshaft end play.
- Position the crankshaft to the rear of the cylinder block.
 - Zero the Dial Indicator Gauge with Holding Fixture.
 - Move the crankshaft to the front of the cylinder block. Note and record the crankshaft end play.
 - Acceptable crankshaft end play is 0.22-0.43 mm (0.008-0.016 in). If the crankshaft end play exceeds the specified range, install new parts as necessary.

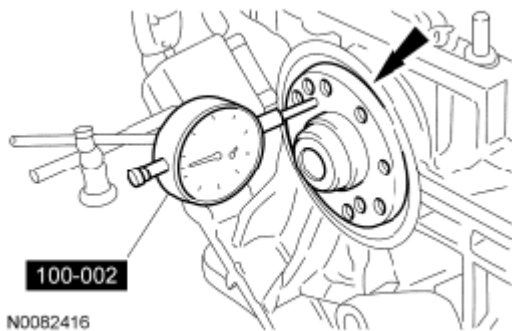

Fig. 404: Measuring Crankshaft End Play

- NOTE:** Be sure not to scratch the cylinder wall or crankshaft journal with the connecting rod. Push the piston down until the connecting rod bearing seats on the crankshaft journal.
- 19.
- NOTE:** Lubricate the pistons, piston rings, connecting rod bearings and the entire cylinder bores with clean engine oil.
- NOTE:** Make sure the piston arrow on top is facing toward the front of the engine.

Using the Piston Ring Compressor and the Connecting Rod Installer, install the piston and connecting rod assemblies.

- When installing the pistons and connecting rod assemblies, the oil ring gaps must be positioned 60

degrees apart from each other and a minimum of 90 degrees from the expander gap.

- The position of the upper and lower compression ring gaps are not controlled for installation.

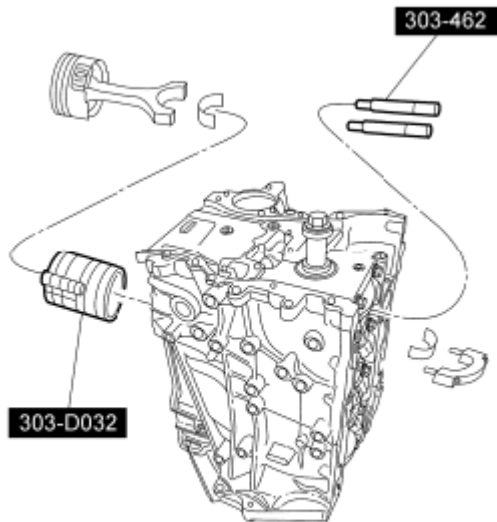

N0082506

Fig. 405: Identifying Piston Ring Compressor And Connecting Rod Installer

20. **NOTE:** The rod cap installation must keep the same orientation as marked during disassembly or engine damage may occur.
- NOTE:** Install connecting rod caps and bolts on the connecting rods for cylinders 1 and 4 first and tighten. Then rotate crankshaft 180 degrees and install connecting rod caps and bolts on connecting rods for cylinders 2 and 3 and tighten.
- NOTE:** After installation of each connecting rod cap, rotate the crankshaft to verify smooth operation.

Install the connecting rod caps and the new bolts.

- Tighten the bolts in 2 stages.
- Stage 1: Tighten to 29 Nm (21 lb-ft).
- Stage 2: Tighten an additional 90 degrees.

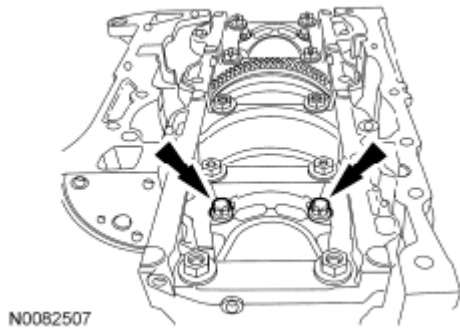

Fig. 406: Locating Connecting Rod Cap Bolts

2.3L engines

21. Install the Crankshaft **TDC** Timing Peg and rotate the crankshaft slowly clockwise until the crankshaft balance weight is up against the Crankshaft **TDC** Timing Peg. The engine is now at Top Dead Center (TDC).

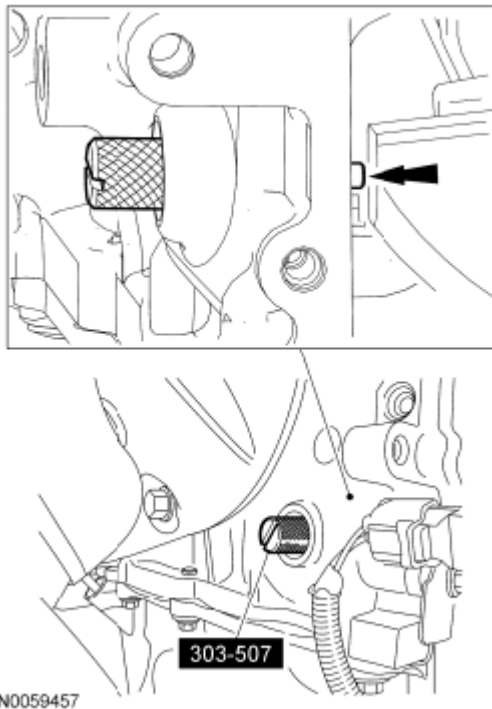

Fig. 407: Installing Crankshaft TDC Timing Peg

22. **NOTE:** Due to the precision interior construction of the balancer unit, it should not be disassembled.
- NOTE:** The original adjustment shims must be installed in their original position.

NOTE: Confirm by visual inspection that there is no damage to the balancer unit gear and verify that the shaft turns smoothly. If there is any damage or malfunction, replace the balancer unit.

Install the adjustment shims in their original position on the seat faces of the balancer unit.

23. With the balancer unit shaft marks in the **TDC** position, slowly install the balancer unit to the cylinder block to avoid interference between the crankshaft drive gear and the balancer unit driven gear.

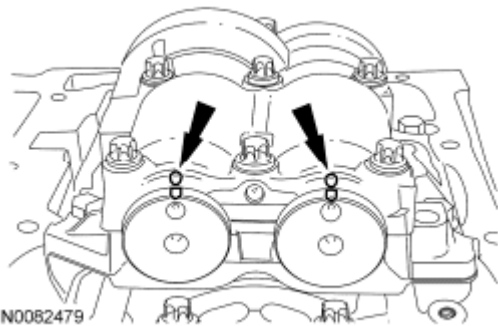

Fig. 408: Locating Balancer Unit And Shafts Reference Mark

24. Install the balancer unit bolts.
- Tighten in the sequence shown in 2 stages.
 - Stage 1: Tighten to 25 Nm (18 lb-ft).
 - Stage 2: Tighten to 50 Nm (37 lb-ft).

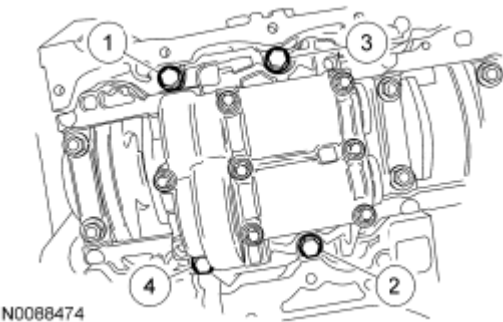

Fig. 409: Identifying Balancer Unit Bolts Tightening Sequence

25. Remove the Crankshaft **TDC** Timing Peg.

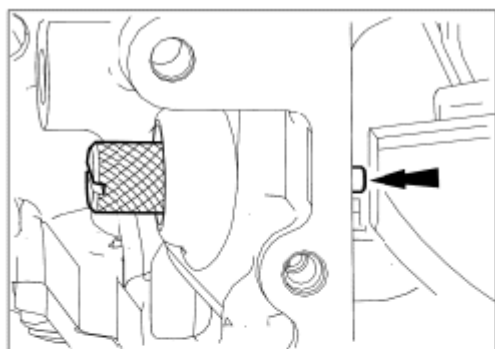

Fig. 410: Installing Crankshaft TDC Timing Peg

26. Rotate the crankshaft to confirm that there are no meshing problems between the balancer unit gear and the crankshaft gear.
27. Install the Crankshaft **TDC** Timing Peg and rotate the crankshaft slowly clockwise until the crankshaft balance weight is up against the Crankshaft **TDC** Timing Peg.
 - Remove the Crankshaft **TDC** Timing Peg.

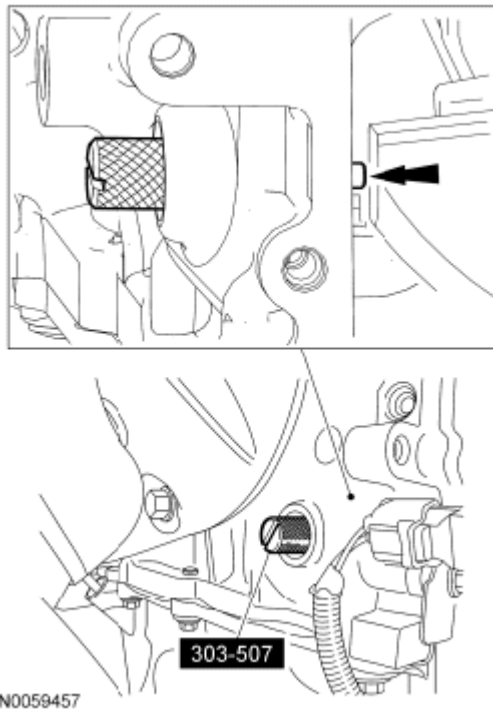

Fig. 411: Installing Crankshaft TDC Timing Peg

28. **NOTE:** Measure the backlash and verify that it is within specified range at all of the following 6 positions: 10 degrees, 30 degrees, 100 degrees, 190 degrees, 210 degrees and 280 degrees. It will be necessary to reset the measuring equipment between measurements.
- NOTE:** The measurement must be taken with the Dial Indicator Gauge with Holding Fixture, a 5-mm Allen wrench and worm clamp set up as shown. Mark the Allen wrench with a file 80 mm (3.149 in) above the driven gear shaft center. Make sure the worm clamp and Allen wrench are not touching the balance shaft housing.
- NOTE:** For an accurate measurement while measuring the gear backlash, insert a screwdriver as shown into the crankshaft No. 1 crankweight area and set both the rotation and the thrust direction with the screwdriver, using a prying action as shown.

Position the Dial Indicator Gauge with Holding Fixture as shown. Measure the gear backlash.

- Position the Dial Indicator Gauge with Holding Fixture (1) on the Allen wrench 80 mm (3.149 in) above the driven gear shaft center (2) on the balancer unit.
- Rotate the crankshaft clockwise and measure the backlash at all of the following 6 positions: 10 degrees, 30 degrees, 100 degrees, 190 degrees, 210 degrees and 280 degrees.

- Backlash specifications are 0.005 to 0.101 mm (0.00019 to 0.0039 in).
- If the backlash exceeds the specified range, carry out the balance shaft backlash procedure. For additional information, refer to the **Balance Shaft Backlash** procedure in this section.

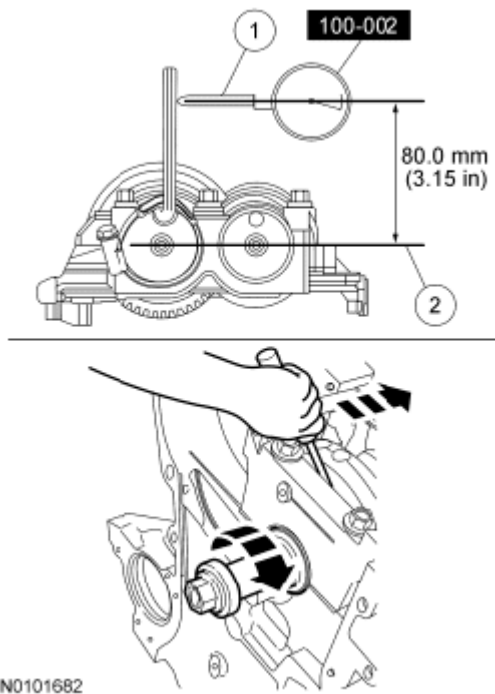

Fig. 412: Measuring Gear Backlash

All engines

29. Install the intermediate shaft bearing bracket and 3 bolts.
 - Tighten to 40 Nm (30 lb-ft).

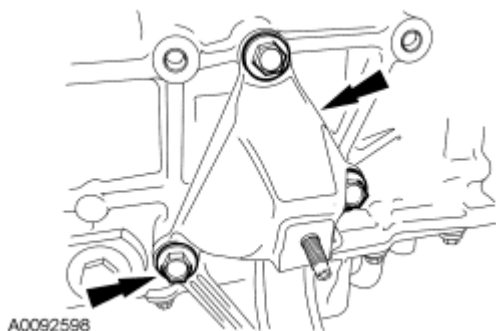

Fig. 413: Locating Intermediate Shaft Bearing Bracket And Bolts
 Courtesy of FORD MOTOR CO.

CAUTION: Failure to position the No. 1 piston at top dead center (TDC) can result in damage to the engine. Turn the engine in the normal

direction of rotation only.

30. Turn the crankshaft clockwise to position the No. 1 piston at TDC.
31. Remove the engine plug bolt.

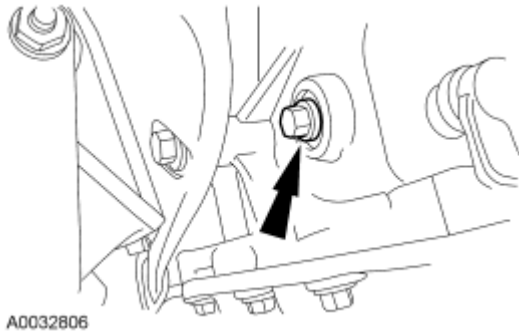

Fig. 414: Locating Engine Plug Bolt
Courtesy of FORD MOTOR CO.

NOTE: The special tool will contact the crankshaft and prevent it from turning past TDC. However, the crankshaft can still be rotated in the counterclockwise direction. The crankshaft must remain at the TDC position until the timing drive components and crankshaft pulley are installed.

32. Install the special tool.

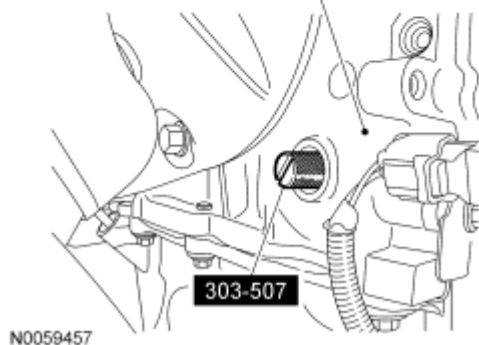
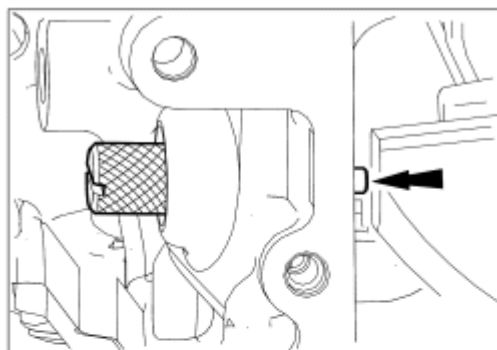
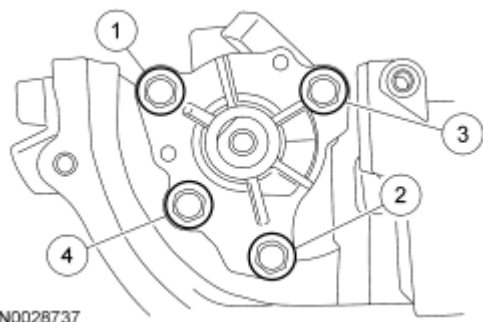

Fig. 415: Identifying Special Tool (303-507)

Courtesy of FORD MOTOR CO.

NOTE: Clean the oil pump and cylinder block mating surfaces with metal surface cleaner.

33. Install the oil pump assembly. Tighten the 4 bolts in the sequence shown in 2 stages.
- Stage 1: Tighten to 10 Nm (89 lb-in).
 - Stage 2: Tighten to 20 Nm (15 lb-ft).

**Fig. 416: Identifying Oil Pump Bolts Tightening Sequence**

Courtesy of FORD MOTOR CO.

34. Install a new oil pump pickup tube gasket and the pickup tube.
- Tighten to 10 Nm (89 lb-in).

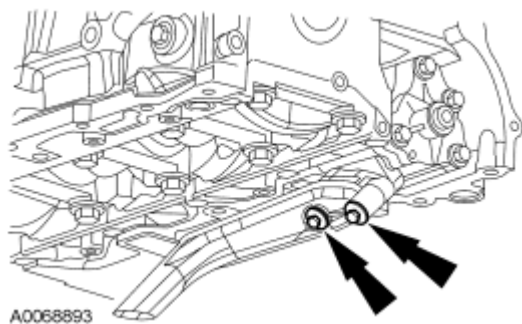
**Fig. 417: Locating Oil Pump Pickup Tube Bolts**

Courtesy of FORD MOTOR CO.

35. Using the special tool, install the crankshaft rear main oil seal.

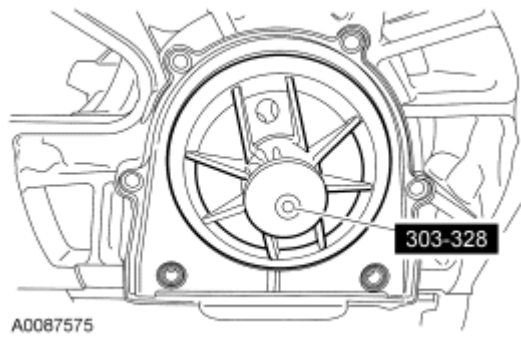

Fig. 418: Identifying Special Tool (303-328)
Courtesy of FORD MOTOR CO.

36. Tighten the 6 crankshaft rear main oil seal bolts in the sequence shown to 10 Nm (89 lb-in).

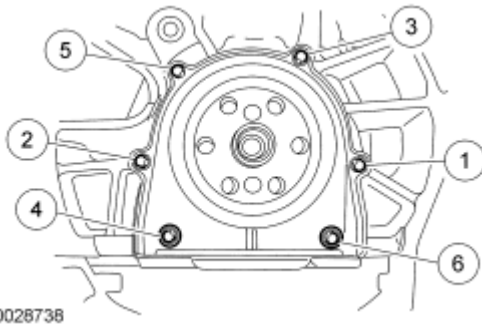

Fig. 419: Identifying Tightening Sequence Of Crankshaft Rear Oil Seal Bolts
Courtesy of FORD MOTOR CO.

CAUTION: Do not use metal scrapers, wire brushes, power abrasive discs or other abrasive means to clean the sealing surfaces. These tools cause scratches and gouges, which make leak paths. Use a plastic scraping tool to remove traces of sealant.

37. Clean and inspect all mating surfaces.

NOTE: If the oil pan is not secured within 4 minutes of sealant application, the sealant must be removed and the sealing area cleaned with metal surface cleaner. Allow to dry until there is no sign of wetness, or 4 minutes, whichever is longer. Failure to follow this procedure can cause future oil leakage.

38. Apply a 2.5 mm (0.10 in) bead of silicone gasket and sealant to the oil pan. Install the oil pan. Install the 2 oil pan bolts finger-tight.

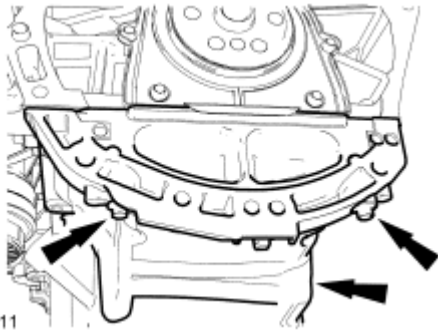

Fig. 420: Identifying Rear Oil Pan Bolts
Courtesy of FORD MOTOR CO.

39. Using a suitable straight edge, align the front surface of the oil pan flush with the front surface of the engine block.

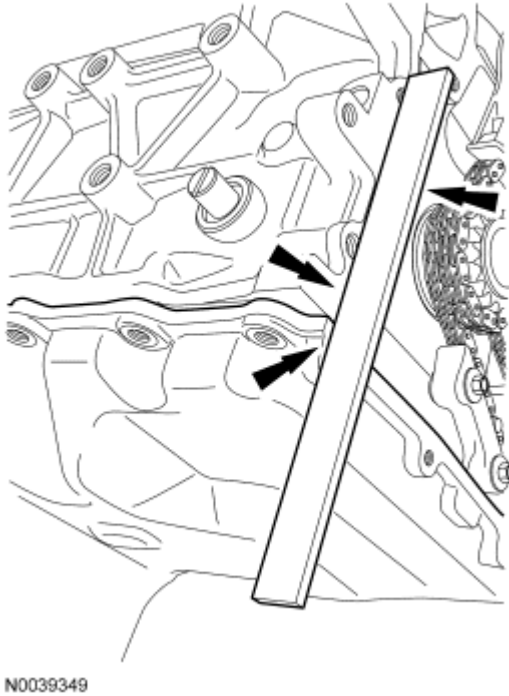

Fig. 421: Aligning Front Surface Of The Oil Pan
Courtesy of FORD MOTOR CO.

40. Install the remaining 13 oil pan bolts and tighten the oil pan bolts in the sequence shown to 25 Nm (18 lb-ft).

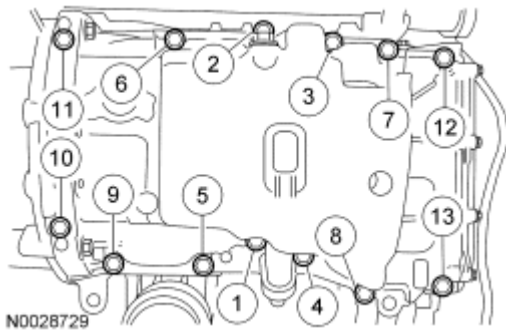

Fig. 422: Identifying Tightening Sequence Of Oil Pan Bolts
Courtesy of FORD MOTOR CO.

41. Install the cylinder head alignment dowels. Dowels must be fully seated in the cylinder block.

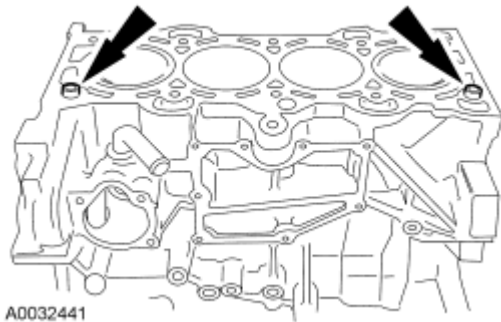

Fig. 423: Identifying Cylinder Head Alignment Dowels
Courtesy of FORD MOTOR CO.

CAUTION: Do not use metal scrapers, wire brushes, power abrasive discs or other abrasive means to clean the sealing surfaces. These tools cause scratches and gouges that make leak paths. Use a plastic scraping tool to remove all traces of the head gasket.

CAUTION: Observe all warnings and cautions and follow all application directions contained on the packaging of the silicone gasket remover and the metal surface prep.

NOTE: If there is no residual gasket material present, metal surface prep can be used to clean and prepare the surfaces.

42. Clean the cylinder head-to-cylinder block mating surface of both the cylinder head and the cylinder block.
1. Remove any large deposits of silicone or gasket material with a plastic scraper.
 2. Apply silicone gasket remover, following package directions, and allow to set for several minutes.
 3. Remove the silicone gasket remover with a plastic scraper. A second application of silicone gasket remover may be required if residual traces of silicone or gasket material remain.
 4. Apply metal surface prep, following package directions, to remove any traces of oil or coolant, and

to prepare the surfaces to bond with the new gasket. Do not attempt to make the metal shiny. Some staining of the metal surfaces is normal.

43. Apply silicone gasket and sealant to the locations shown.

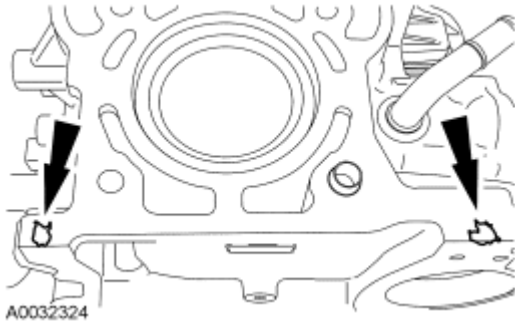

Fig. 424: Identifying Silicone Gasket And Sealant Location
Courtesy of FORD MOTOR CO.

44. Install a new head gasket.

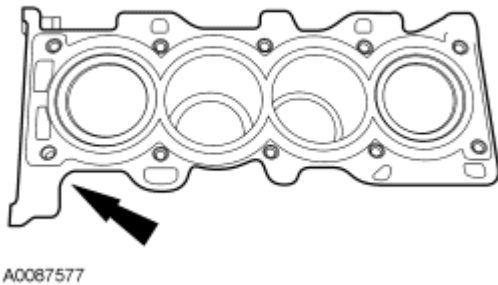

Fig. 425: Locating Head Gasket
Courtesy of FORD MOTOR CO.

NOTE: The cylinder head bolts are torque-to-yield and must not be reused. New cylinder head bolts must be installed.

NOTE: Lubricate the bolts with clean engine oil prior to installation.

45. Install the cylinder head and 10 new bolts. Tighten the bolts in the sequence shown in 5 stages.
- Stage 1: Tighten to 5 Nm (44 lb-in).
 - Stage 2: Tighten to 15 Nm (11 lb-ft).
 - Stage 3: Tighten to 45 Nm (33 lb-ft).
 - Stage 4: Turn 90 degrees.
 - Stage 5: Turn an additional 90 degrees.

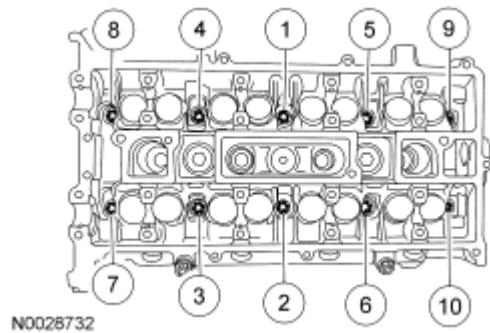

Fig. 426: Identifying Tightening Sequence Of Cylinder Head Bolts
Courtesy of FORD MOTOR CO.

CAUTION: Install the camshafts with the alignment slots in the camshafts lined up so the Camshaft Alignment Plate can be installed without rotating the camshafts. Make sure the lobes on the No. 1 cylinder are in the same position as noted in the disassembly procedure. Rotating the camshafts when the timing chain is removed, or installing the camshafts 180 degrees out of position, can cause severe damage to the valves and pistons.

NOTE: Lubricate the camshaft journals and bearing caps with clean engine oil.

46. Install the camshafts and bearing caps in their original location and orientation. Tighten the bearing caps in the sequence shown in 3 stages:
- Stage 1: Tighten one turn at a time until tight.
 - Stage 2: Tighten to 7 Nm (62 lb-in).
 - Stage 3: Tighten to 16 Nm (12 lb-ft).

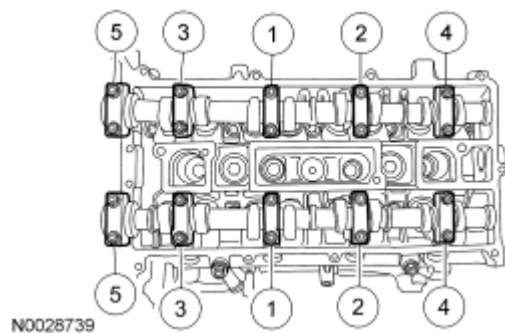

Fig. 427: Identifying Tightening Sequence Of Camshaft Bearing Cap Bolts
Courtesy of FORD MOTOR CO.

NOTE: Install a new crankshaft sprocket diamond washer on both sides of the crankshaft sprocket.

47. Install the crankshaft sprocket, new crankshaft sprocket diamond washers, oil pump chain and oil pump

sprocket.

- The crankshaft sprocket flange must be facing away from the engine block.

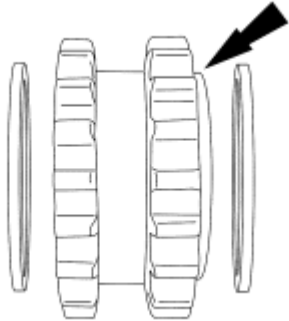

A0083166

Fig. 428: Locating Washers, Oil Pump Chain & Sprockets
 Courtesy of FORD MOTOR CO.

48. Install the oil pump chain, sprocket and bolt.
 - Tighten to 25 Nm (18 lb-ft).

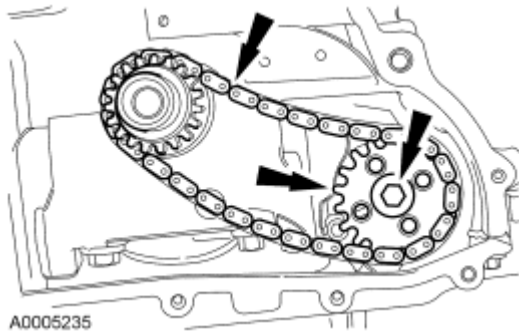

A0005235

Fig. 429: Locating Oil Pump Chain, Sprocket And Bolt
 Courtesy of FORD MOTOR CO.

Late build vehicles

49. Install the oil pump drive chain tensioner shoulder bolt.
 - Tighten to 10 Nm (89 lb-in).

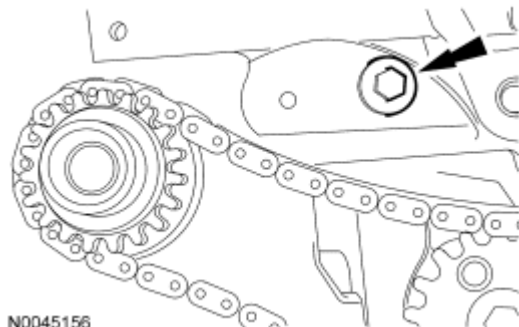

N0045156

Fig. 430: Locating Oil Pump Chain Drive Tensioner Shoulder Bolt
 Courtesy of FORD MOTOR CO.

Early build vehicles

50. Install the oil pump drive chain guide and the 3 shoulder bolts.
 - Tighten to 10 Nm (89 lb-in).

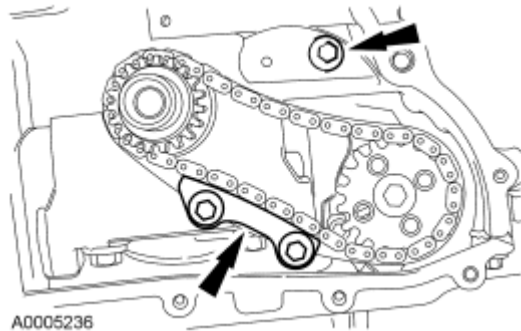

Fig. 431: Installing Oil Pump Drive Chain Guide And Shoulder Bolts
 Courtesy of FORD MOTOR CO.

All vehicles

51. Install the oil pump chain tensioner and bolt. Hook the tensioner spring around the shoulder bolt.
 - Tighten to 10 Nm (89 lb-in).

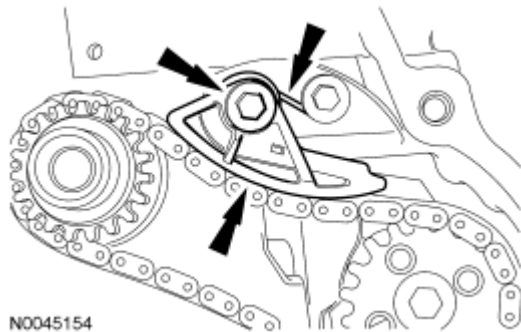

Fig. 432: Locating Oil Pump Chain Tensioner
 Courtesy of FORD MOTOR CO.

CAUTION: The special tool 303-465 is for camshaft alignment only. Using this tool to prevent engine rotation can result in engine damage.

52. Install the special tool in the slots on the rear of both camshafts.

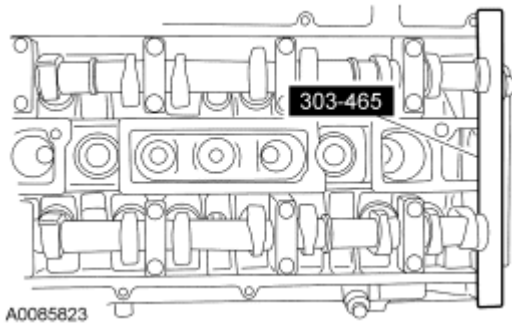

Fig. 433: Identifying Special Camshaft Tool (303-465)
 Courtesy of FORD MOTOR CO.

53. Install the camshaft sprockets and the bolts. Do not tighten the bolts at this time.

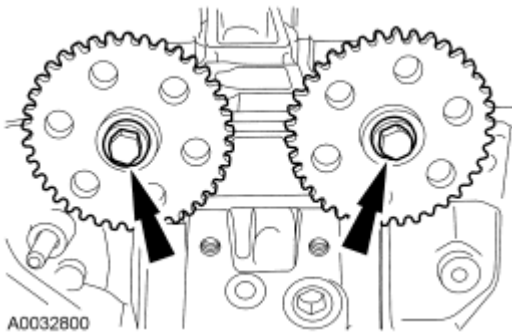

Fig. 434: Locating Camshaft Sprocket Bolts
 Courtesy of FORD MOTOR CO.

54. Install the LH timing chain guide and the 2 bolts.

- Tighten to 10 Nm (89 lb-in).

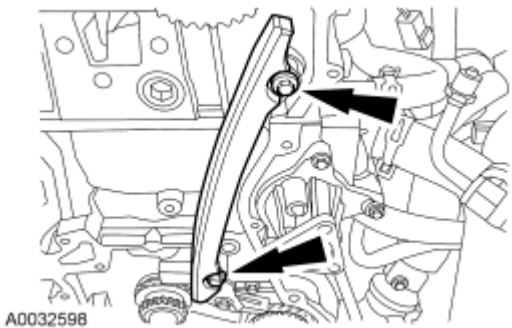
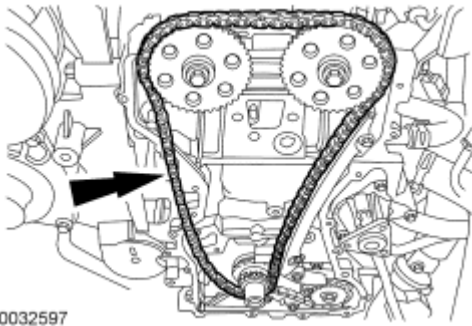

Fig. 435: Identifying Bolts And LH Timing Chain Guide
 Courtesy of FORD MOTOR CO.

55. Install the timing chain.



A0032597

Fig. 436: View Of Timing Chain
Courtesy of FORD MOTOR CO.

56. Install the RH timing chain guide.

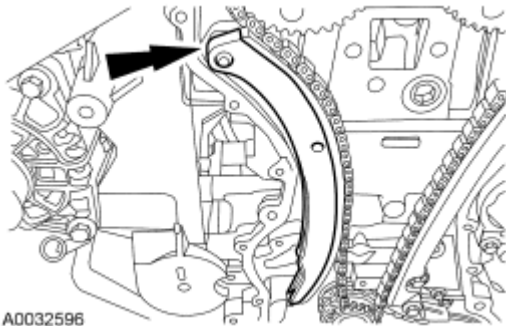

A0032596

Fig. 437: Locating RH Timing Chain Guide
Courtesy of FORD MOTOR CO.

CAUTION: Do not compress the ratchet assembly. This will damage the ratchet assembly.

57. Using the edge of a vise, compress the timing chain tensioner plunger.

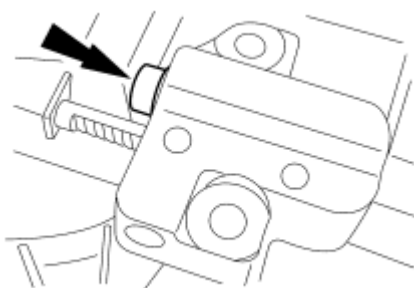

A0032539

Fig. 438: Locating Timing Chain Tensioner Plunger
Courtesy of FORD MOTOR CO.

58. Using a small pick, push back and hold the ratchet mechanism.

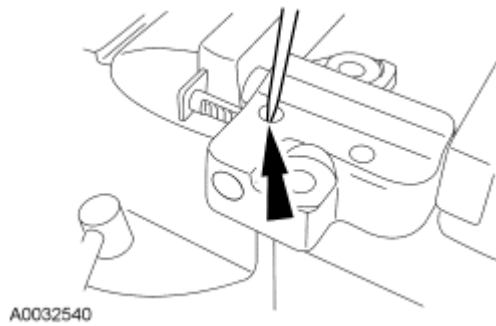

Fig. 439: Holding Ratchet Mechanism Using Small Pick
 Courtesy of FORD MOTOR CO.

59. While holding the ratchet mechanism, push the ratchet arm back into the tensioner housing.

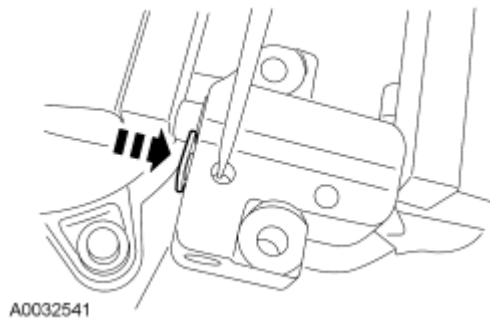

Fig. 440: Pushing Ratchet Arm Back Into Tensioner Housing
 Courtesy of FORD MOTOR CO.

60. Install a paper clip into the hole in the tensioner housing to hold the ratchet assembly and the plunger in during installation.

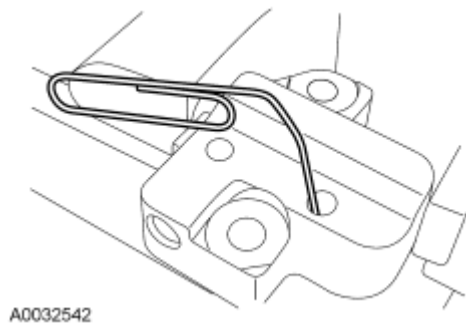

Fig. 441: Installing Paper Clip Into Hole In Tensioner Housing To Hold Ratchet Assembly
 Courtesy of FORD MOTOR CO.

61. Install the timing chain tensioner and the 2 bolts. Remove the paper clip to release the piston.
- Tighten to 10 Nm (89 lb-in).

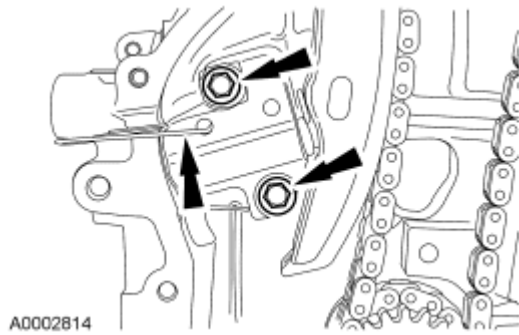

Fig. 442: Locating Timing Chain Tensioner Bolts And Paper Clip
 Courtesy of FORD MOTOR CO.

CAUTION: The special tool 303-465 is for camshaft alignment only. Using this tool to prevent engine rotation can result in engine damage.

62. Using the flats on the camshafts to prevent camshaft rotation, tighten the camshaft sprocket bolts to 72 Nm (53 lb-ft).

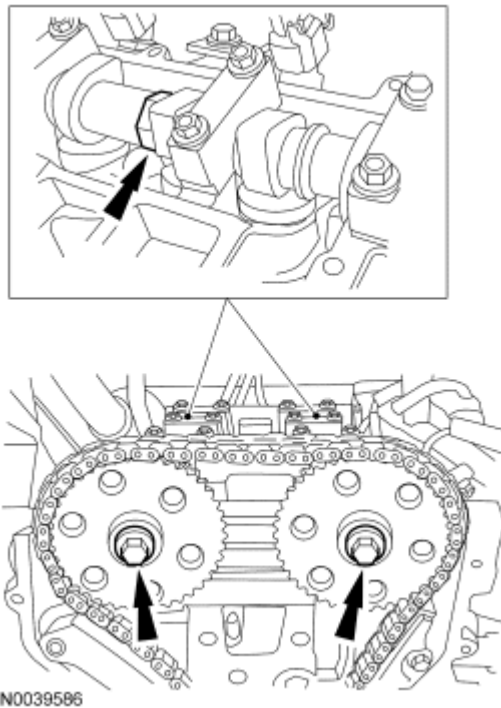

Fig. 443: Locating Camshaft Bolts
 Courtesy of FORD MOTOR CO.

CAUTION: Do not use metal scrapers, wire brushes, power abrasive disks or other abrasive means to clean sealing surfaces. These tools cause scratches and gouges which make leak paths.

63. Clean and inspect the mounting surfaces of the engine and the front cover.

NOTE: The engine front cover must be installed and the bolts tightened within 4 minutes of applying the silicone gasket and sealant.

64. Apply a 2.5 mm (0.10 in) bead of silicone gasket and sealant to the cylinder head and oil pan joint areas. Apply a 2.5 mm (0.10 in) bead of silicone gasket and sealant to the front cover.

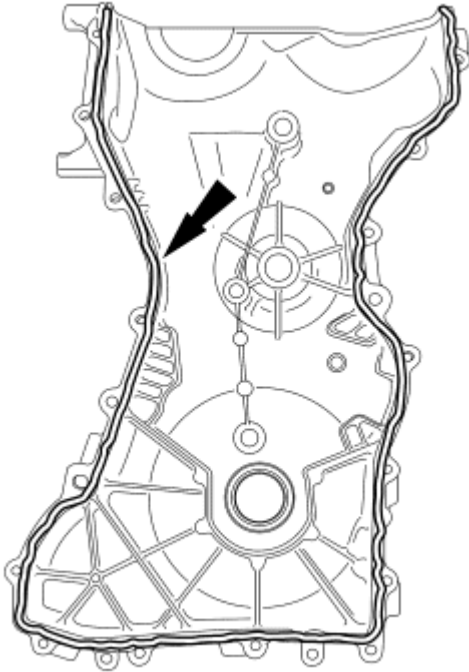

A0032803

Fig. 444: Locating Silicone Gasket
Courtesy of FORD MOTOR CO.

65. Install the engine front cover. Tighten the 22 bolts in the sequence shown to the following specifications:

- Tighten the 8 mm bolts to 10 Nm (89 lb-in).
- Tighten the 13 mm bolts to 48 Nm (35 lb-ft).

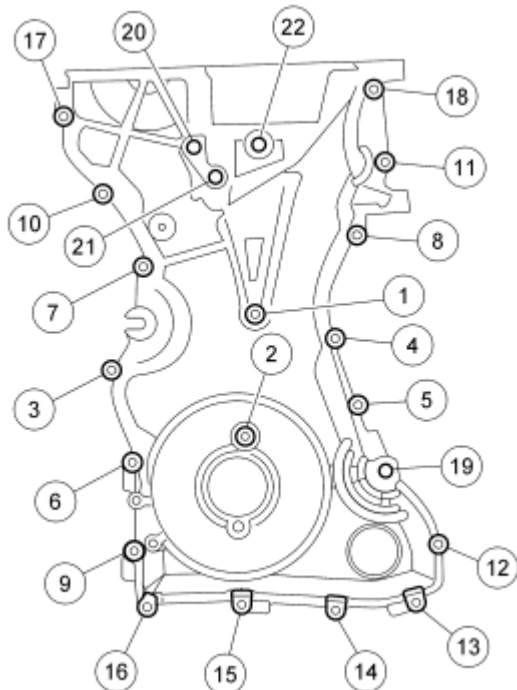

N0028728

Fig. 445: Identifying Engine Front Cover Bolts Tightening Sequence
 Courtesy of FORD MOTOR CO.

NOTE: Remove the through-bolt from the special tool.

NOTE: Lubricate the oil seal with clean engine oil.

66. Using the special tool, install a new crankshaft front oil seal.

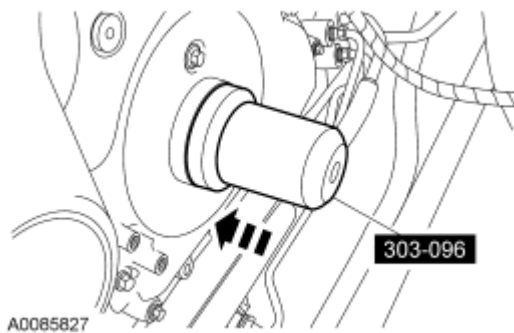

A0085827

Fig. 446: Installing Crankshaft Front Oil Seal Using Special Tool (303-096)
 Courtesy of FORD MOTOR CO.

CAUTION: Do not install the crankshaft pulley bolt at this time.

NOTE: Apply clean engine oil on the seal area before installing.

67. Position the crankshaft pulley onto the crankshaft with the hole in the pulley at the 6 o'clock position.

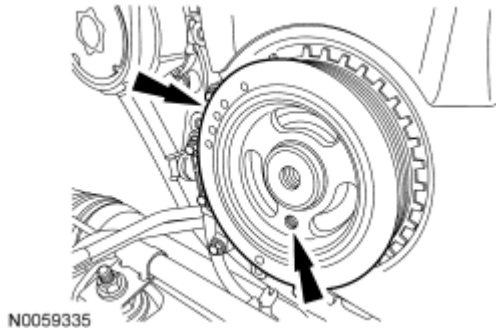

Fig. 447: Locating Crankshaft Pulley & Hole
Courtesy of FORD MOTOR CO.

CAUTION: Only hand-tighten the 6 mm (0.23 in) bolt or damage to the front cover can occur.

NOTE: This step will correctly align the crankshaft pulley to the crankshaft.

68. Install a standard 6 mm (0.23 in) x 18 mm (0.7 in) bolt through the crankshaft pulley and thread it into the front cover.

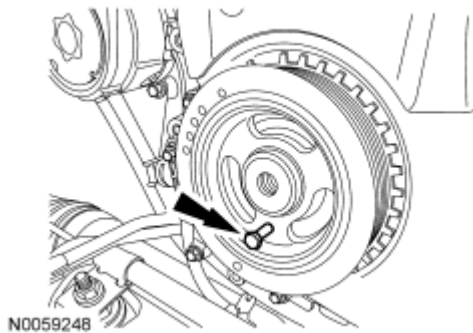
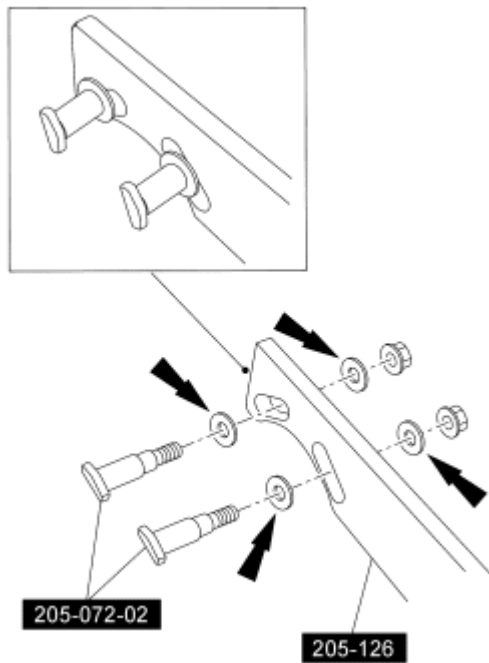

Fig. 448: Locating Crankshaft Pulley Bolt
Courtesy of FORD MOTOR CO.

69. Assemble the special tools using 4 hardened washers in the locations shown.



N0059336

Fig. 449: Assembling Special Tools (205-126 And 205-072-02)
Courtesy of FORD MOTOR CO.

CAUTION: The crankshaft must remain in the TDC position during installation of the pulley bolt or damage to the engine can occur. Therefore, the crankshaft pulley must be held in place with the special tool and the bolt should be installed using hand tools only.

CAUTION: Do not reuse the crankshaft pulley bolt.

70. Install a new crankshaft pulley bolt. Using the special tools to hold the crankshaft pulley in place, tighten the crankshaft pulley bolt in 2 stages:
 - Stage 1: Tighten to 100 Nm (74 lb-ft).
 - Stage 2: Tighten an additional 90 degrees (1/4 turn).

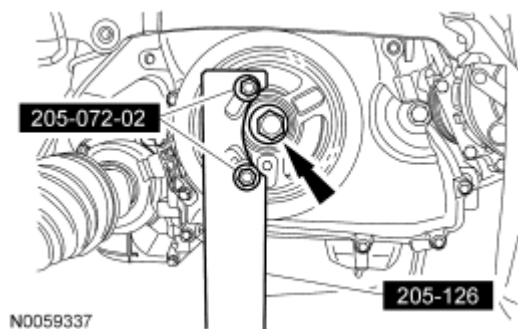

Fig. 450: Using Special Tools (205-126 And 205-072-02)
Courtesy of FORD MOTOR CO.

71. Remove the 6 mm (0.23 in) x 18 mm (0.7 in) bolt.

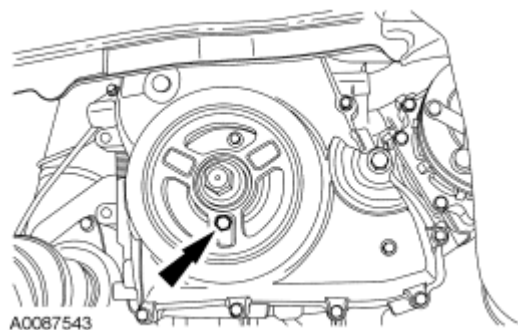

Fig. 451: Aligning Crankshaft Pulley Bolt Holes
Courtesy of FORD MOTOR CO.

72. Remove the special tool.

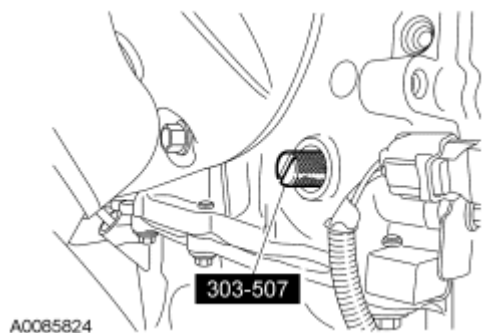

Fig. 452: Identifying Special Tool (303-507)
Courtesy of FORD MOTOR CO.

73. Remove the special tool.

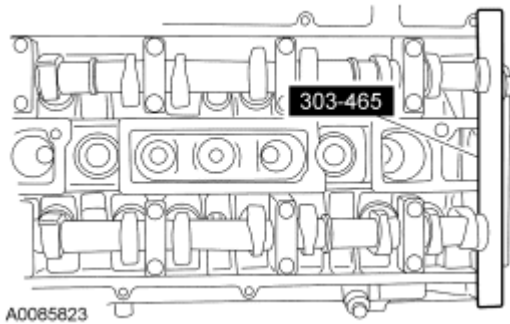

Fig. 453: Identifying Special Camshaft Tool (303-465)
Courtesy of FORD MOTOR CO.

NOTE: Only turn the engine in the normal direction of rotation.

74. Turn the crankshaft clockwise 1 and 3/4 turns.
75. Install the special tool.

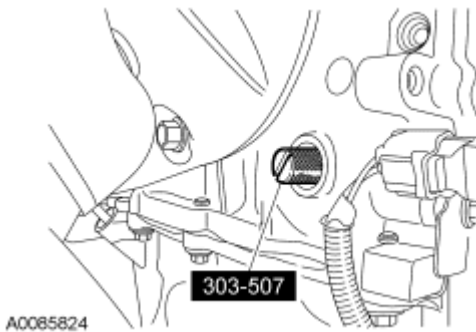

Fig. 454: Identifying Special Tool (303-507)
Courtesy of FORD MOTOR CO.

NOTE: Only turn the engine in the normal direction of rotation.

76. Turn the crankshaft clockwise until the crankshaft contacts the special tool.

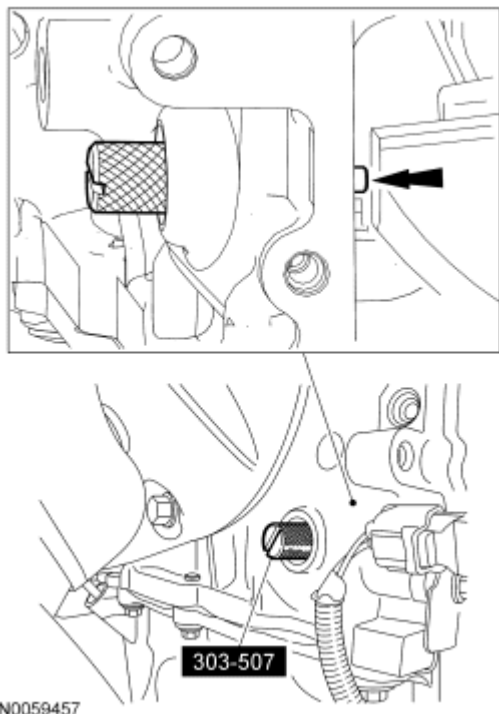

Fig. 455: Identifying Special Tool (303-507)
 Courtesy of FORD MOTOR CO.

CAUTION: Only hand-tighten the bolt or damage to the front cover can occur.

77. Using the 6 mm (0.23 in) x 18 mm (0.7 in) bolt, check the position of the crankshaft pulley.
 - If it is not possible to install the bolt, the engine valve timing must be corrected.

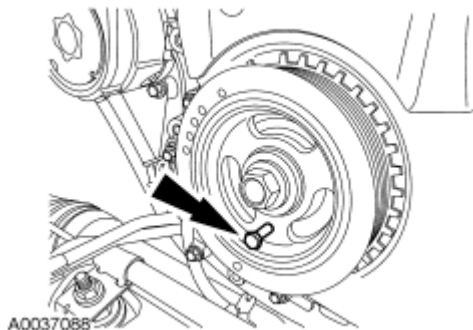

Fig. 456: Installing Bolt Through Crankshaft Pulley And Thread It Into Front Cover
 Courtesy of FORD MOTOR CO.

78. Install the special tool to check the position of the camshafts.
 - If it is not possible to install the special tool, the engine valve timing must be corrected.

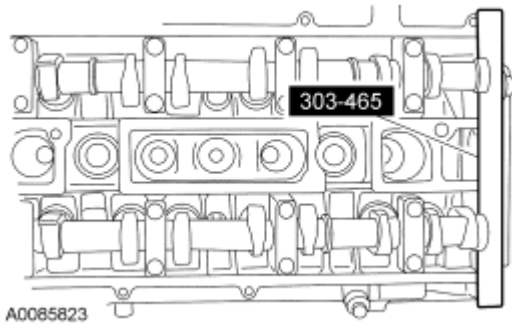

Fig. 457: Identifying Special Camshaft Tool (303-465)
Courtesy of FORD MOTOR CO.

79. Remove the special tool.

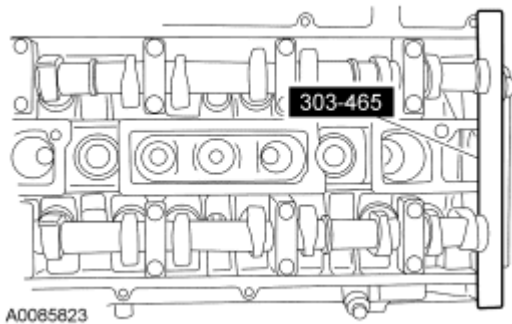

Fig. 458: Identifying Special Camshaft Tool (303-465)
Courtesy of FORD MOTOR CO.

NOTE: Whenever the crankshaft position (CKP) sensor is removed, a new one must be installed using the alignment tool supplied with the new part.

80. Install a new CKP sensor and the 2 bolts.

- Do not tighten the bolts at this time.

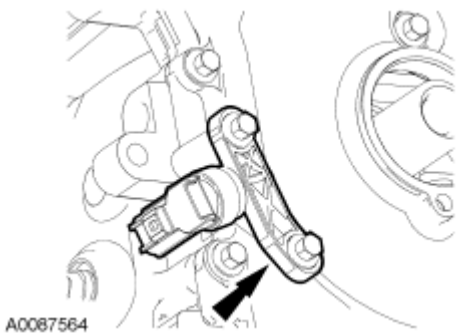

Fig. 459: Locating CKP Sensor
Courtesy of FORD MOTOR CO.

NOTE: The CKP sensor alignment tool is supplied with the new sensor and is not available separately.

81. Adjust the CKP sensor with the alignment tool.
 - Tighten the 2 CKP bolts to 7 Nm (62 lb-in).

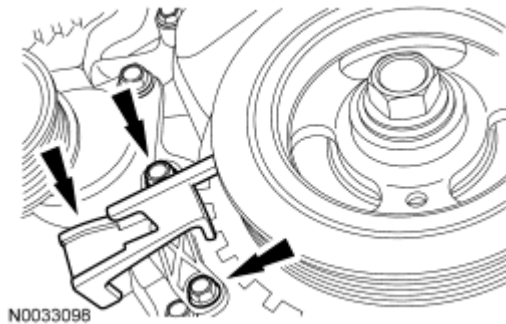

Fig. 460: Locating CKP Sensor Alignment Tool And Bolts
Courtesy of FORD MOTOR CO.

82. Remove the 6 mm (0.23 in) x 18 mm (0.7 in) bolt.

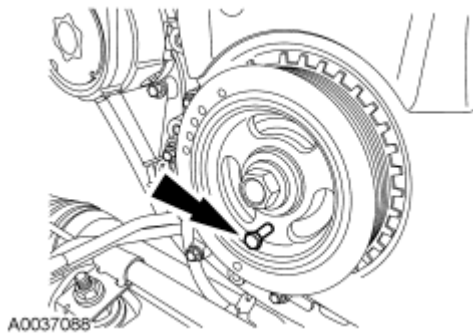

Fig. 461: Installing Bolt Through Crankshaft Pulley And Thread It Into Front Cover
Courtesy of FORD MOTOR CO.

83. Remove the special tool.



Fig. 462: Identifying Special Tool (303-507)

Courtesy of FORD MOTOR CO.

84. Install the engine plug bolt.
 - Tighten to 20 Nm (15 lb-ft).

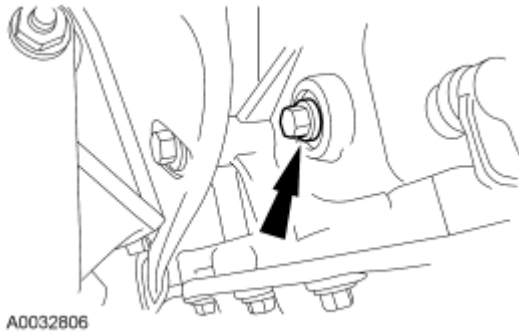

Fig. 463: Locating Engine Plug Bolt
Courtesy of FORD MOTOR CO.

CAUTION: Do not use metal scrapers, wire brushes, power abrasive discs or other abrasive means to clean the sealing surfaces. These tools cause scratches and gouges which make leak paths.

85. Clean the valve cover gasket surface with metal surface cleaner.
86. Apply silicone gasket and sealant to the locations shown.



A0032732

Fig. 464: Locating Silicone Gasket Applying Area
Courtesy of FORD MOTOR CO.

NOTE: The valve cover must be secured within 4 minutes of silicone gasket application. If the valve cover is not secured within 4 minutes, the sealant must be removed and the sealing area cleaned with metal surface cleaner.

87. Install the valve cover.
 - Tighten the 14 bolts in the sequence shown to 10 Nm (89 lb-in).

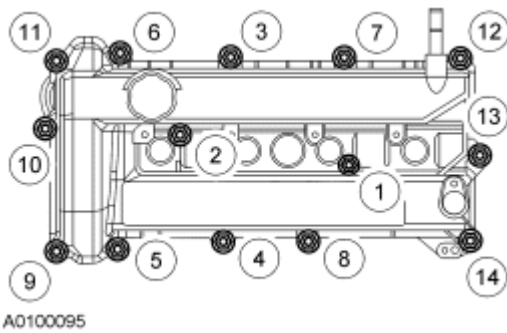

Fig. 465: Identifying Valve Cover Bolts Tightening Sequence
 Courtesy of FORD MOTOR CO.

CAUTION: Only use hand tools when removing or installing the spark plugs, damage can occur to the cylinder head or spark plug.

88. Install a new cylinder head temperature (CHT) sensor and the spark plugs.
- Tighten the CHT sensor to 12 Nm (9 lb-ft).
 - Tighten the spark plugs to 12 Nm (9 lb-ft).

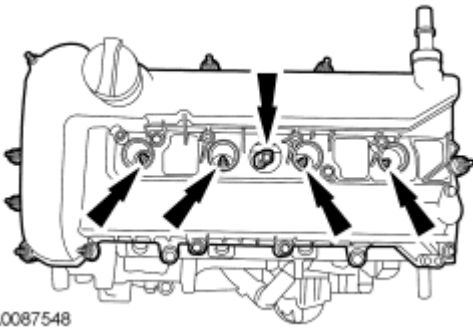
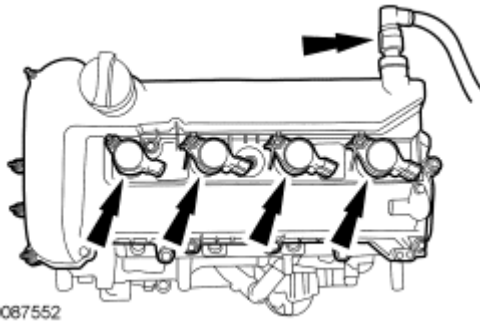

Fig. 466: Locating Cylinder Head Temperature Sensor And Spark Plugs
 Courtesy of FORD MOTOR CO.

NOTE: Apply dielectric compound to the inside of the coil-on-plug boots.

89. Install the 4 coil-on-plugs, 4 bolts and the crankcase vent tube.
- Tighten to 10 Nm (89 lb-in).



A0087552

Fig. 467: Locating Crankcase Vent Tube And Coil-On-Plugs
 Courtesy of FORD MOTOR CO.

90. If equipped, install the block heater.
- Tighten to 21 Nm (15 lb-ft).

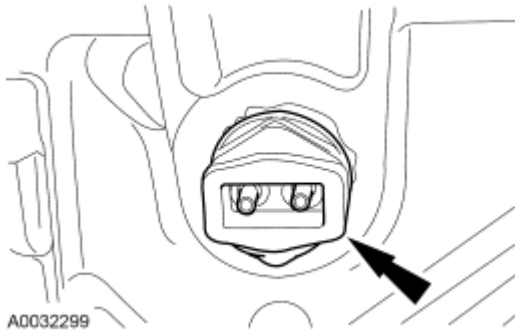

A0032299

Fig. 468: Locating Block Heater
 Courtesy of FORD MOTOR CO.

NOTE: The knock sensor (KS) must not touch the crankcase vent oil separator.

91. Install the crankcase vent oil separator and the KS.
- Tighten the 8 oil separator bolts to 10 Nm (89 lb-in).
 - Tighten the KS to 20 Nm (15 lb-ft).

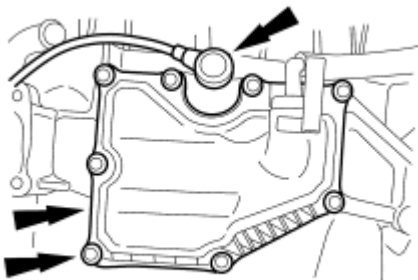

A0100094

Fig. 469: Locating Crankcase Vent Oil Separator, KS And Bolts
 Courtesy of FORD MOTOR CO.

92. Install the coolant bypass hose.

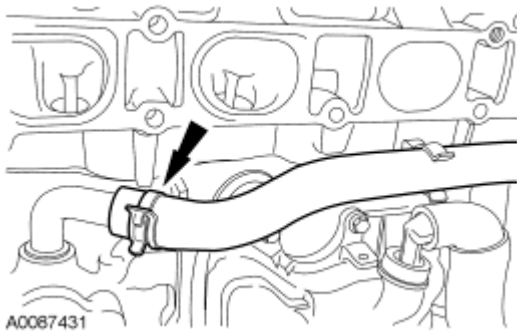

Fig. 470: Locating Coolant Bypass Hose
Courtesy of FORD MOTOR CO.

93. Using a new gasket, install the coolant bypass and 4 bolts.

- Tighten to 10 Nm (89 lb-in).

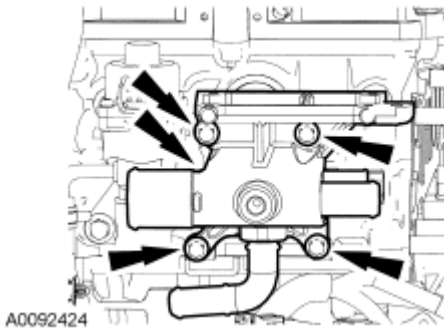

Fig. 471: Locating Coolant Bypass And Bolts
Courtesy of FORD MOTOR CO.

94. Connect the coolant bypass hose.

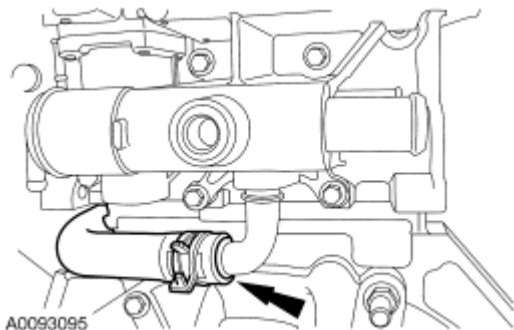

Fig. 472: Locating Coolant Bypass Hose
Courtesy of FORD MOTOR CO.

95. Install the coolant hose.

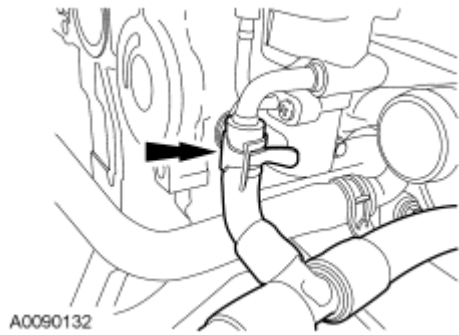

Fig. 473: Locating Coolant Hose
Courtesy of FORD MOTOR CO.

96. Position the engine control wiring harness on the engine and connect the CHT sensor and install the rubber boot.

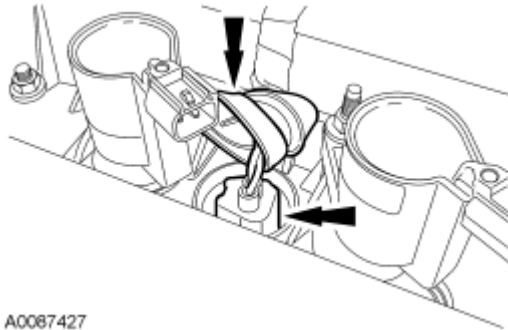

Fig. 474: Locating Cylinder Head Temperature Sensor Electrical Connector And Rubber Boot
Courtesy of FORD MOTOR CO.

97. Connect the coil-on-plug and camshaft position (CMP) sensor electrical connectors.

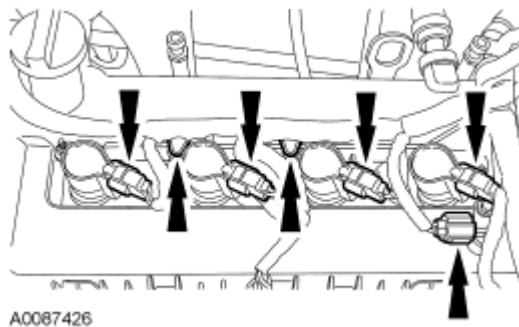
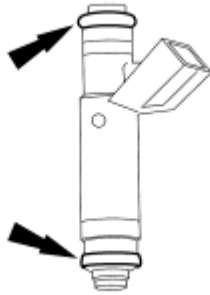

Fig. 475: Locating Camshaft Position Sensor Electrical Connectors And Coil-On-Plug
Courtesy of FORD MOTOR CO.

CAUTION: Use O-ring seals that are made of special fuel-resistant material. Use of ordinary O-rings can cause the fuel system to leak. Do not reuse the O-ring seals.

98. Install new fuel injector O-rings.
- Separate the fuel injectors from the fuel rail.
 - Remove and discard the fuel injector O-rings.
 - Install new O-rings and lubricate with clean engine oil.
 - Install the fuel injectors onto the fuel rail.



AV1418-A

Fig. 476: Identifying Fuel Injector O-Ring Seals
 Courtesy of FORD MOTOR CO.

99. Install the fuel rail with the fuel injectors and the 2 bolts.
- Tighten to 25 Nm (18 lb-ft).

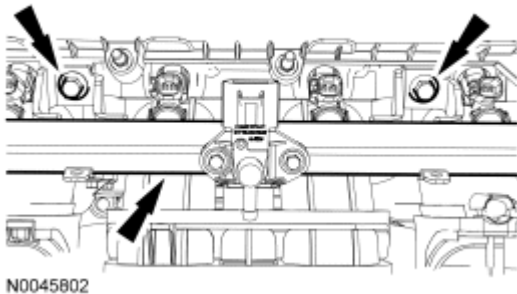

N0045802

Fig. 477: Locating Fuel Rail Bolts And Fuel Rail
 Courtesy of FORD MOTOR CO.

100. Connect the fuel charging wiring harness.
- Connect the fuel rail pressure and temperature sensor electrical connector.
 - Connect the 4 fuel injector electrical connectors.
 - Attach the wiring harness retainers.

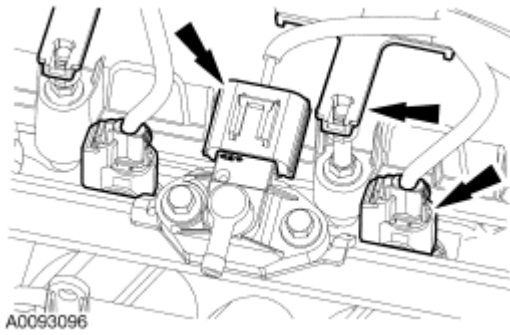

Fig. 478: Locating Fuel Charging Wiring Harness
Courtesy of FORD MOTOR CO.

101. Connect the wiring harness retainers to the valve cover studs.

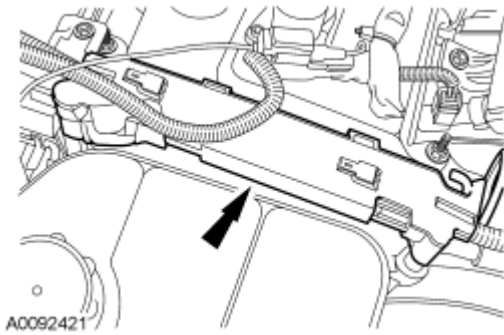

Fig. 479: Locating Wiring Harness Retainers
Courtesy of FORD MOTOR CO.

102. Install the radio interference capacitor bracket and bolt.
 - Tighten to 10 Nm (89 lb-in).

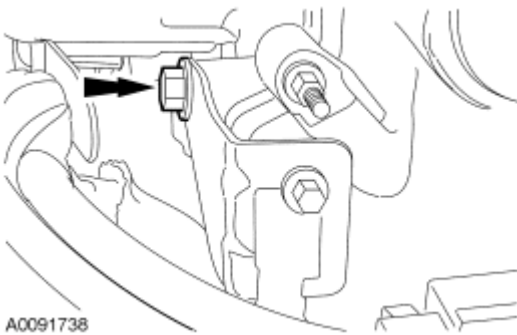

Fig. 480: Locating Radio Interference Capacitor Bracket Bolt
Courtesy of FORD MOTOR CO.

103. Install the EGR tube.
 - Tighten to 55 Nm (41 lb-ft).

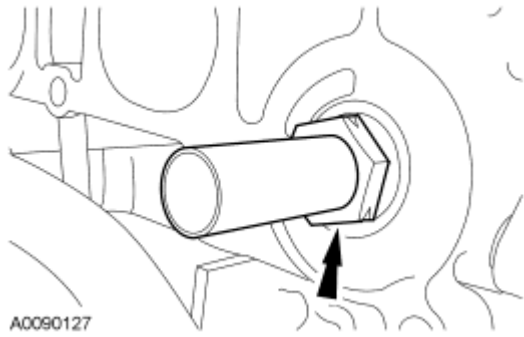

Fig. 481: Locating Exhaust Gas Recirculation Tube
 Courtesy of FORD MOTOR CO.

104. Inspect and install new intake manifold gaskets if necessary.
105. Position the intake manifold and connect the positive crankcase ventilation (PCV) hose.

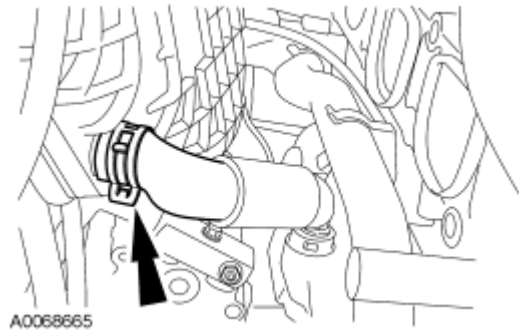

Fig. 482: Locating Positive Crankcase Ventilation Hose
 Courtesy of FORD MOTOR CO.

2.3L engines

NOTE: Be sure to install the bolts in the previously marked locations.

106. Install the intake manifold and the 7 mounting bolts.
 - Tighten to 18 Nm (13 lb-ft).

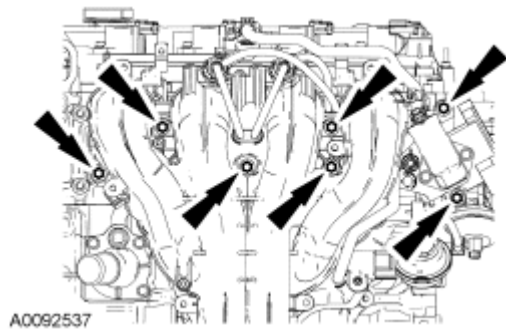

Fig. 483: Locating Intake Manifold Bolts

Courtesy of FORD MOTOR CO.

NOTE: Lubricate the O-ring with clean engine oil.

107. Install the oil level indicator tube assembly and 2 bolts.

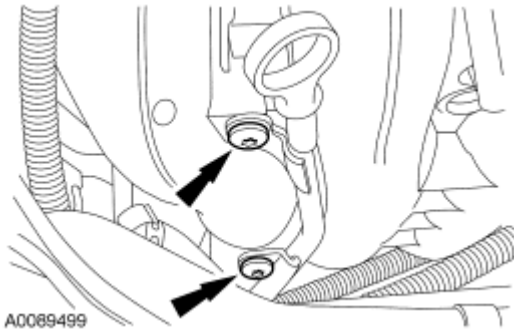

Fig. 484: Locating Oil Level Indicator Tube Bolts
Courtesy of FORD MOTOR CO.

108. Connect the swirl valve electrical connectors and pin-type retainers.

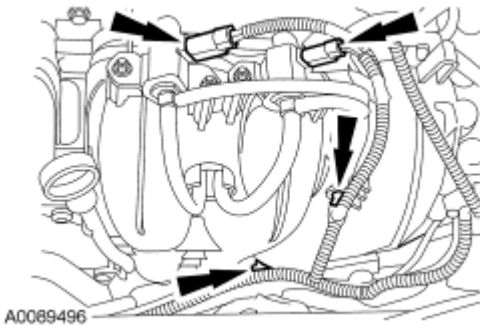

Fig. 485: Locating Swirl Valve Electrical Connectors And Pin-Type Retainers
Courtesy of FORD MOTOR CO.

2.0L engines

NOTE: Be sure to install the bolts in the previously marked locations.

109. Install the intake manifold and the 7 mounting bolts.

- Tighten to 18 Nm (13 lb-ft).

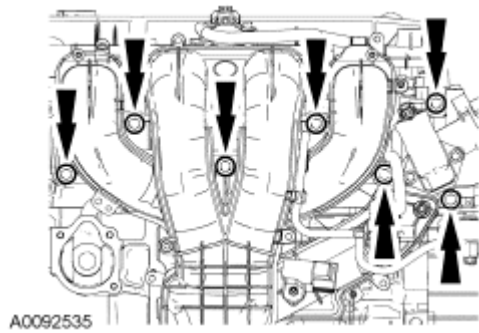

Fig. 486: Locating Intake Manifold Bolts
 Courtesy of FORD MOTOR CO.

NOTE: Lubricate the O-ring with clean engine oil.

110. Install the oil level indicator tube assembly and bolt.
 - Tighten to 10 Nm (89 lb-in).

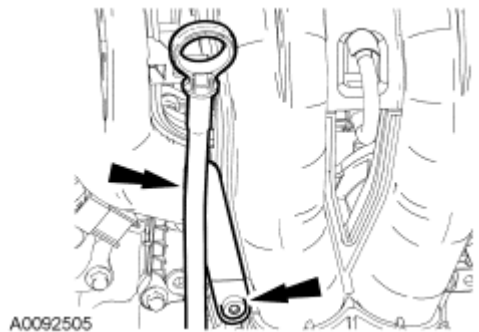

Fig. 487: Locating Bolt And Oil Level Indicator Tube
 Courtesy of FORD MOTOR CO.

111. Connect the swirl control valve electrical connector.

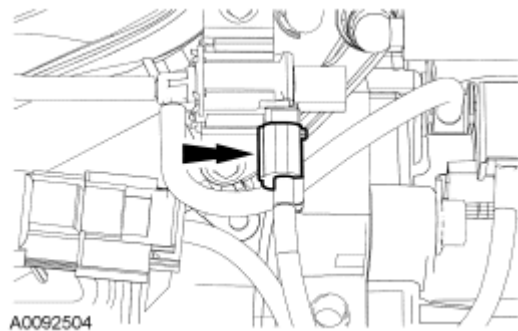

Fig. 488: Locating Swirl Control Valve Electrical Connector
 Courtesy of FORD MOTOR CO.

112. If equipped, connect the secondary air injection (AIR) vacuum supply hose.

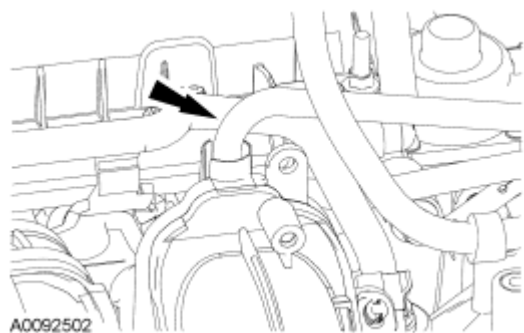

Fig. 489: Locating Secondary Air Injection Vacuum Supply Hose
Courtesy of FORD MOTOR CO.

All engines

113. Connect the manifold absolute pressure (MAP) electrical connector.



Fig. 490: Locating Manifold Absolute Pressure Sensor Electrical Connector
Courtesy of FORD MOTOR CO.

114. Connect the intake manifold runner control (IMRC) actuator electrical connector.

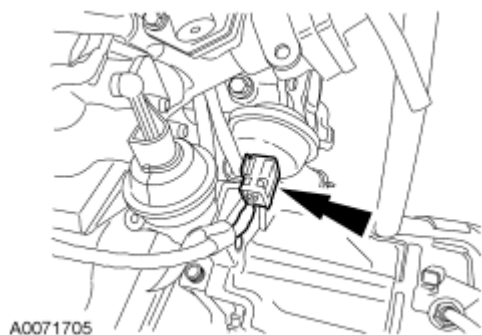

Fig. 491: Locating Intake Manifold Runner Control Actuator Electrical Connector
Courtesy of FORD MOTOR CO.

115. Attach the wiring harness pin-type retainer.

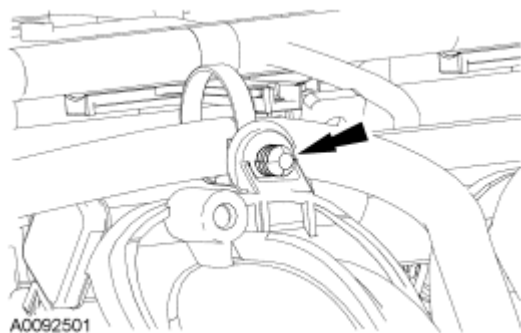

Fig. 492: Locating Wiring Harness Pin-Type Retainer
Courtesy of FORD MOTOR CO.

116. Connect the fuel rail pressure and temperature sensor vacuum hose.

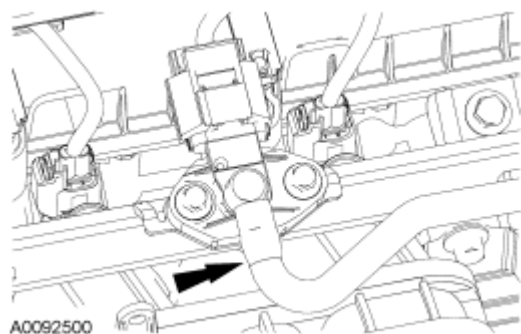

Fig. 493: Locating Fuel Rail Pressure And Temperature Sensor Vacuum Hose
Courtesy of FORD MOTOR CO.

117. Connect the idle air control (IAC) valve electrical connector and wiring harness pin-type retainer.

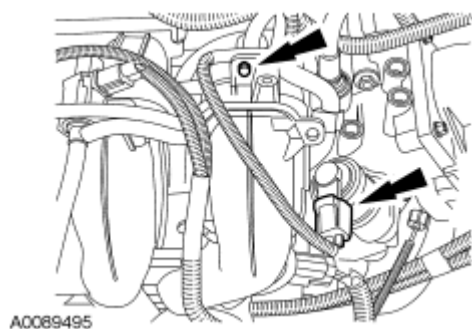
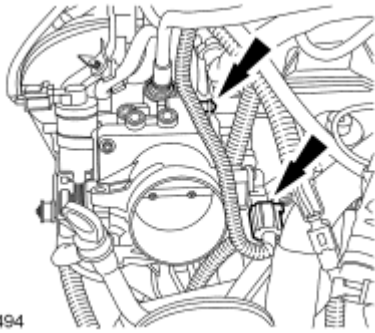

Fig. 494: Locating Idle Air Control Valve Electrical Connector And Wiring Harness Pin-Type Retainer
Courtesy of FORD MOTOR CO.

118. Connect the throttle position (TP) sensor electrical connector and wiring harness pin-type retainer.



A0089494

Fig. 495: Locating Throttle Position Sensor Electrical Connector And Wiring Harness Pin-Type Retainer
Courtesy of FORD MOTOR CO.

119. Install the lower intake bolt.
- Tighten to 18 Nm (13 lb-ft).



A0068656

Fig. 496: Locating Lower Intake Manifold Bolt
Courtesy of FORD MOTOR CO.

120. Connect the KS electrical connector and pin-type retainer.

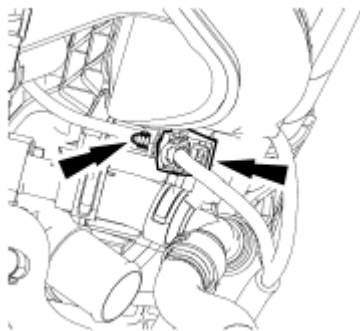

A0092600

Fig. 497: Locating Knock Sensor Electrical Connector And Pin-Type Retainer
Courtesy of FORD MOTOR CO.

NOTE: Clean the gasket mating surfaces with metal surface cleaner.

121. Install the oil filter adapter with a new gasket.

- Tighten to 25 Nm (18 lb-ft).

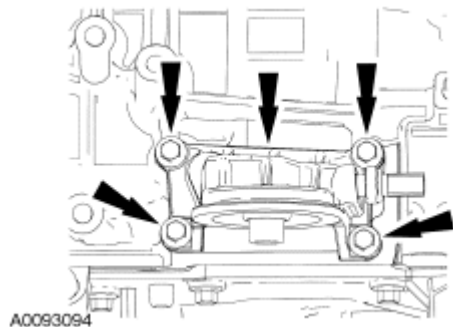

Fig. 498: Locating Oil Filter Adapter And Bolts
Courtesy of FORD MOTOR CO.

122. Install a new oil filter.

- Tighten the oil filter 3/4 turn after the oil filter gasket makes contact with the oil filter adapter.

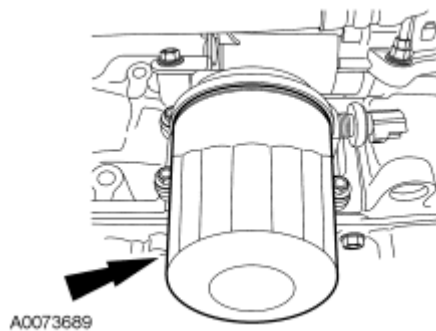

Fig. 499: Locating Engine Oil Filter
Courtesy of FORD MOTOR CO.

123. Connect the oil pressure sensor electrical connector.

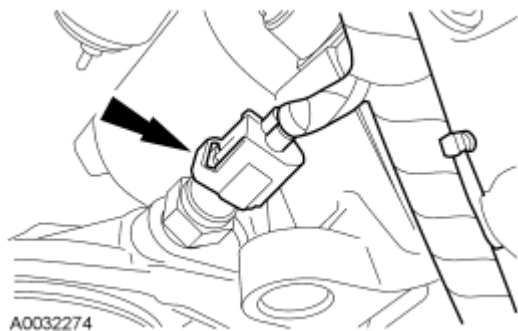

Fig. 500: Locating Engine Oil Pressure (EOP) Sensor Electrical Connector
Courtesy of FORD MOTOR CO.

NOTE: Clean and inspect the thermostat housing gasket. Install a new gasket if necessary.

124. Install the thermostat housing and 3 bolts.

- Tighten to 10 Nm (89 lb-in).

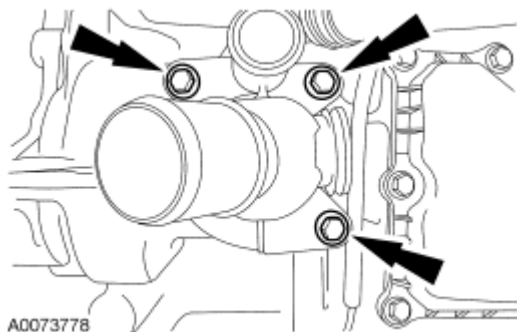

Fig. 501: Locating Thermostat Housing Bolts
Courtesy of FORD MOTOR CO.

125. Connect the heater hose to the thermostat housing.

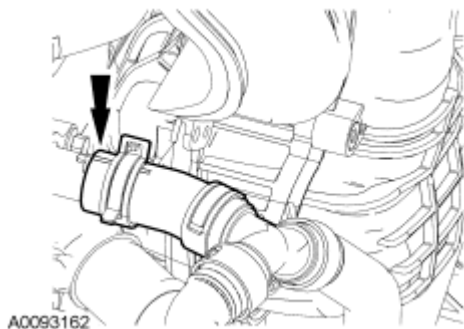

Fig. 502: Locating Heater Hose
Courtesy of FORD MOTOR CO.

NOTE: Clean the coolant pump mating surface with metal surface cleaner.

NOTE: Lubricate the coolant pump O-ring with clean engine coolant.

126. Position the coolant pump and install the 3 bolts.

- Tighten to 10 Nm (89 lb-in).

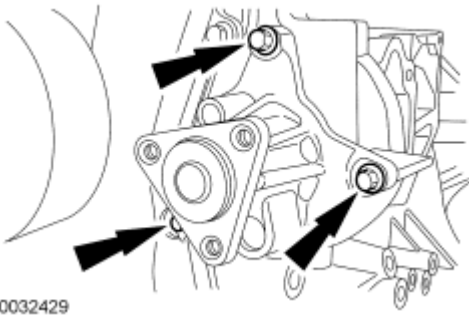

Fig. 503: Locating Coolant Pump Bolts
Courtesy of FORD MOTOR CO.

127. Install the coolant pump pulley and 3 bolts.
- Tighten to 20 Nm (15 lb-ft).

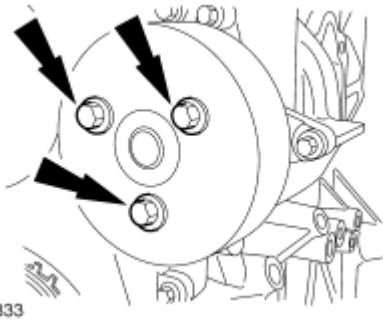

Fig. 504: Locating Coolant Pump Pulley Bolts
Courtesy of FORD MOTOR CO.

128. If equipped, install the accessory drive belt idler pulley.
- Tighten to 25 Nm (18 lb-ft).

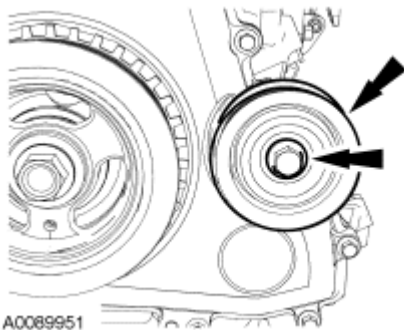

Fig. 505: Locating Accessory Drive Belt Idler Pulley And Bolt
Courtesy of FORD MOTOR CO.

129. Install the accessory drive belt idler pulley.
- Tighten to 25 Nm (18 lb-ft).

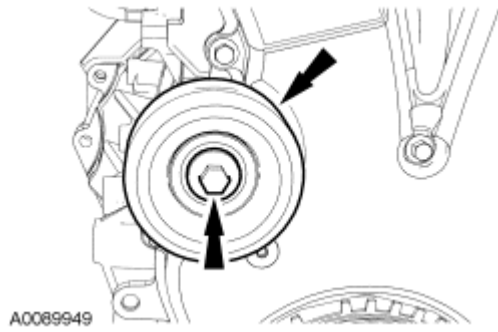

Fig. 506: Locating Accessory Drivebelt Idler Pulley And Bolt
 Courtesy of FORD MOTOR CO.

130. Install the accessory drivebelt tensioner and 2 bolts.
- Tighten to 25 Nm (18 lb-ft).

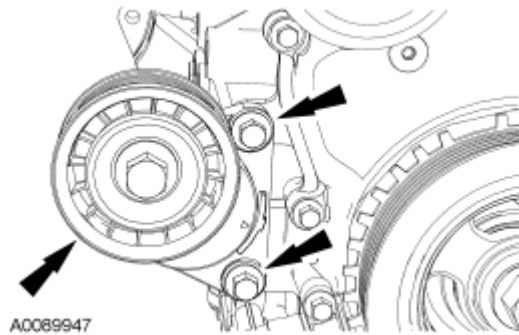

Fig. 507: Locating Accessory Drive Belt Tensioner Bolts
 Courtesy of FORD MOTOR CO.

131. Install the generator, bolt and 2 stud bolts.
- Tighten to 25 Nm (18 lb-ft).

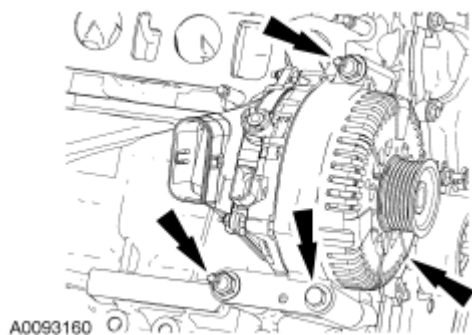

Fig. 508: Locating Generator And Bolts
 Courtesy of FORD MOTOR CO.

132. Install the wiring harness retainer and nut.
- Tighten to 25 Nm (18 lb-ft).

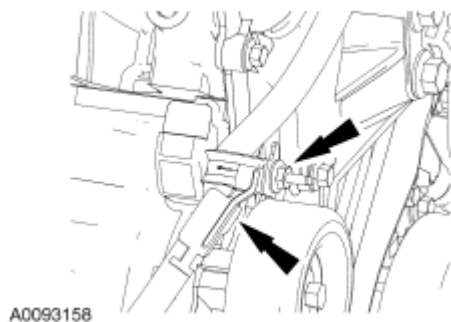

Fig. 509: Locating Wiring Harness Retainer And Nut
Courtesy of FORD MOTOR CO.

133. Connect the generator electrical connections, harness retainer and install the nut.
- Tighten to 8 Nm (71 lb-in).

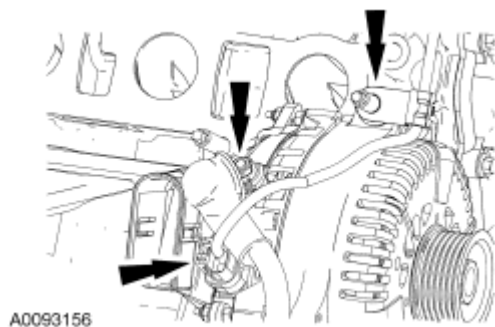

Fig. 510: Locating Generator Electrical Connections And Wiring Harness Retainer
Courtesy of FORD MOTOR CO.

134. Install the generator heat shield and 2 nuts.
- Tighten to 18 Nm (13 lb-ft).

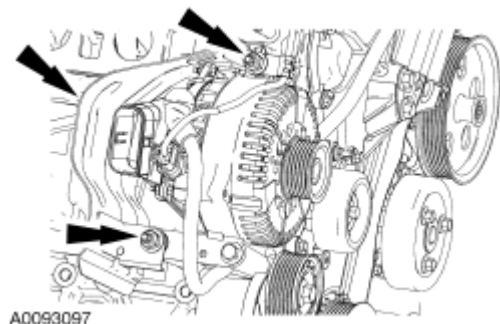
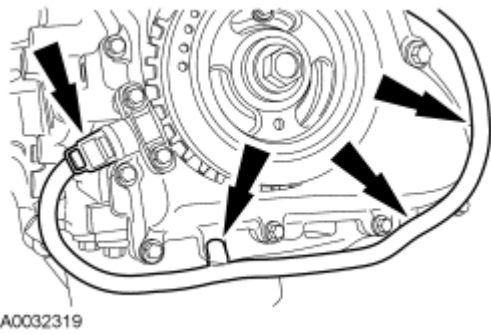

Fig. 511: Locating Generator Heat Shield And Nuts
Courtesy of FORD MOTOR CO.

135. Connect the CKP sensor and the wiring harness pin-type retainers.



A0032319

Fig. 512: Locating Crankshaft Position Sensor And Wiring Harness Pin-Type Retainers
Courtesy of FORD MOTOR CO.

136. Using the heavy duty floor crane and spreader bar, remove the engine from the engine stand.
137. Install the flexplate and the 6 bolts. Tighten the bolts in the sequence shown in 3 stages:
 - Stage 1: Tighten to 50 Nm (37 lb-ft).
 - Stage 2: Tighten to 80 Nm (59 lb-ft).
 - Stage 3: Tighten to 112 Nm (83 lb-ft).

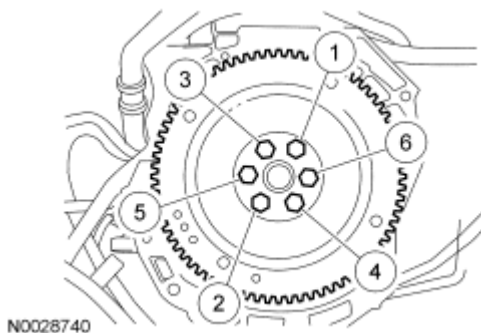

N0028740

Fig. 513: Identifying Flexplate Bolts Tightening Sequence
Courtesy of FORD MOTOR CO.

Engines equipped with a manual transmission

138. Lubricate the transaxle input shaft pilot bearing with front axle grease.

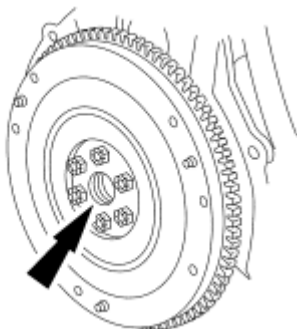

A0027749

Fig. 514: Locating Transmission Input Shaft Pilot Bearing

Courtesy of FORD MOTOR CO.

139. Using the special tool, position the clutch disc on the flywheel.

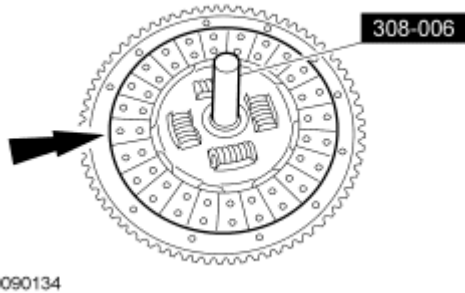

Fig. 515: Locating Special Tool And Clutch Disc (308-006)
 Courtesy of FORD MOTOR CO.

NOTE: If reusing the clutch pressure plate and flywheel, align the marks made during removal.

140. Position the clutch pressure plate and install the 7 bolts. Tighten the bolts in a star pattern sequence to 27 Nm (20 lb-ft).

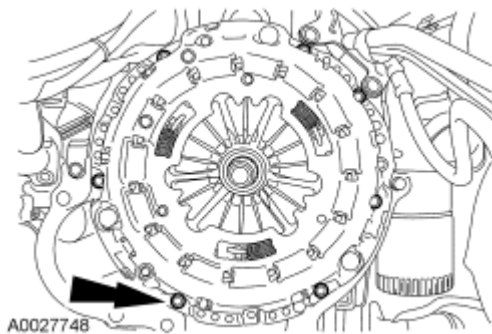

Fig. 516: Locating Clutch Pressure Plate Bolts
 Courtesy of FORD MOTOR CO.

INSTALLATION





ENGINE

Special Tools

Illustration	Tool Name	Tool Number
	Heavy Duty Floor Crane	014-00071 or equivalent

2007 Ford Focus S

2007 ENGINE Engine - 2.0L and 2.3L - Focus

 <p>ST1341-A</p>		
 <p>ST1602-A</p>	<p>Spreader Bar</p>	<p>303-D089 (D93P-6001-A3) or equivalent</p>
 <p>ST1682-A</p>	<p>Powertrain Lift with Tilting Plate</p>	<p>014-00765 or equivalent</p>
 <p>ST2743A</p>	<p>Universal Adapter Brackets</p>	<p>014-0001</p>
 <p>ST1595-A</p>	<p>Lifting Brackets, Engine</p>	<p>303-050 (T70P-6000)</p>

Material

Item	Specification
<p>Motorcraft SAE 5W-20 Premium Synthetic Blend Motor Oil XO-5W20-QSP (US); Motorcraft SAE 5W-20 Super Premium Motor Oil CXO-5W20-LSP12 (Canada); or equivalent</p>	<p>WSS-M2C930-A</p>
<p>Multi-Purpose Grease XG-4 and/or XL-5</p>	<p>ESB-M1C93-B</p>

Vehicles equipped with a 2.0L engine and automatic transmission

NOTE: Lubricate the torque converter pilot hub with multi-purpose grease.

1. Check the installation depth of the torque converter.
 1. Lay a straightedge on the automatic transaxle flange.

2. Check the installation depth between the transaxle flange and the torque converter centering spigot for the correct clearance.

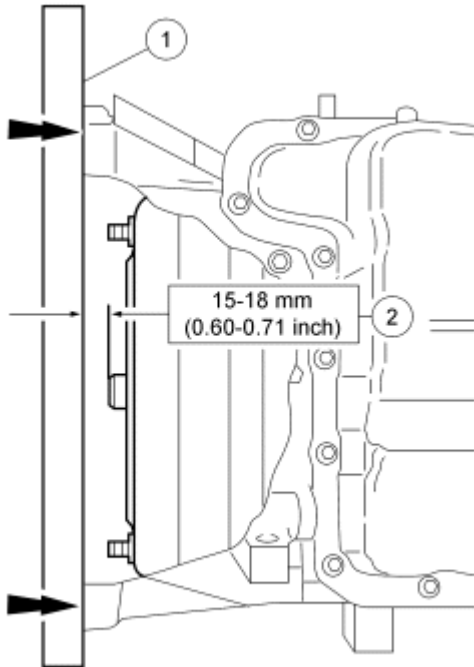

N0033318

Fig. 517: Locating Depth Between Transaxle Flange And Torque Converter Centering Spigot For Correct Clearance

Courtesy of FORD MOTOR CO.

All vehicles

2. Install new dowel pins in the engine block.

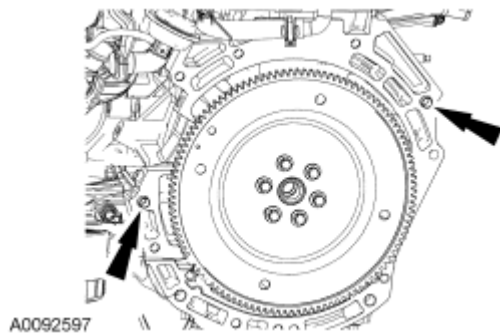

A0092597

Fig. 518: Locating Dowel Pins

Courtesy of FORD MOTOR CO.

3. Using the engine crane, install the transaxle onto the engine.
 1. Install the 2 bolts at the dowel pins.

- Tighten to 48 Nm (35 lb-ft).
2. Install the remaining bolts.
 - Tighten to 48 Nm (35 lb-ft).

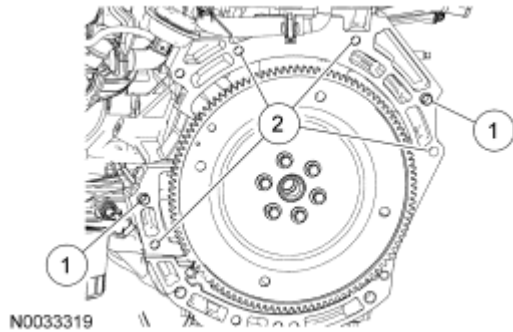

Fig. 519: Locating Bolts
Courtesy of FORD MOTOR CO.

4. Using the special tools, raise the engine and transaxle assembly onto the lift table.

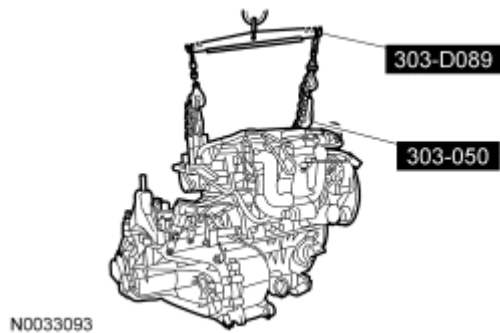
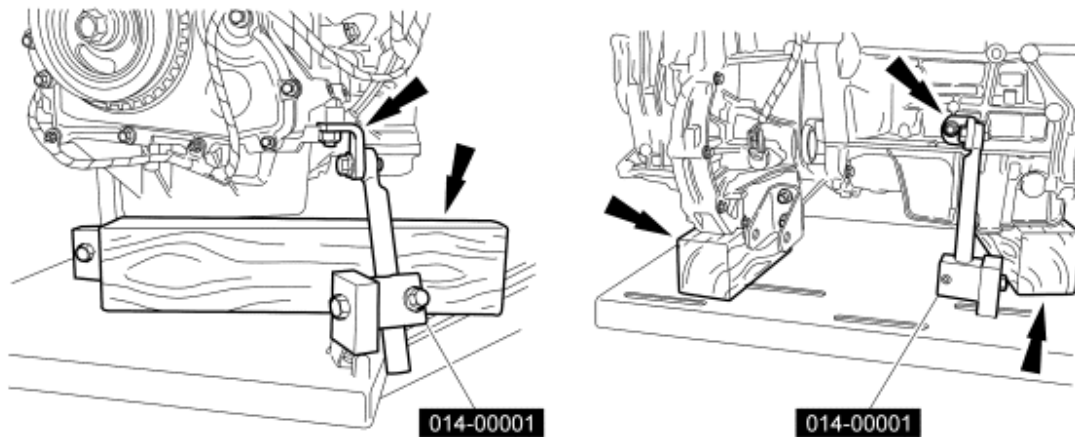

Fig. 520: Identifying Special Tools (303-D089, 303-050)
Courtesy of FORD MOTOR CO.

5. Using the special tools, secure the engine and transaxle assembly to the lift table.



N0033092

Fig. 521: Identifying Special Tools (014-00001)
Courtesy of FORD MOTOR CO.

Vehicles equipped with a 2.0L engine and automatic transmission

6. Connect the solenoid body and the transmission range (TR) sensor electrical connectors.

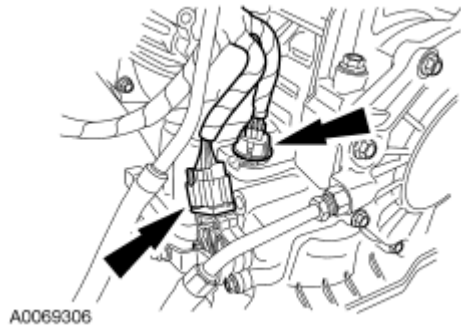

Fig. 522: Locating Transmission Range Sensor Electrical Connectors
Courtesy of FORD MOTOR CO.

7. Connect the turbine shaft speed (TSS) sensor electrical connector.

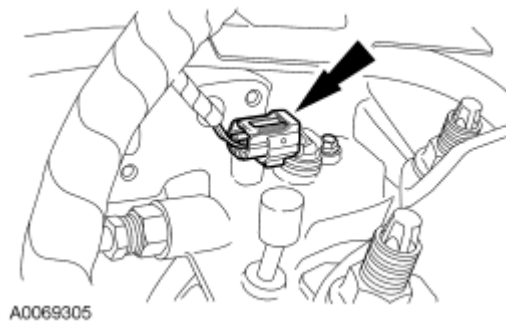

Fig. 523: Locating Turbine Shaft Speed (TSS) Sensor Electrical Connector

Courtesy of FORD MOTOR CO.

8. Connect the output shaft speed (OSS) sensor electrical connector.

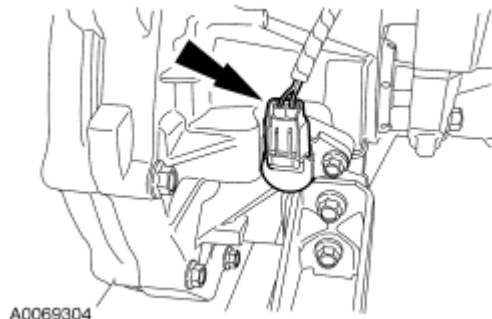

Fig. 524: Locating Output Shaft Speed Sensor Electrical Connector
Courtesy of FORD MOTOR CO.

NOTE: If new parts are not being used, be sure to align the marks on the flexplate and the stud made during engine removal.

9. Install the 4 torque converter nuts.
 - Tighten to 35 Nm (26 lb-ft).

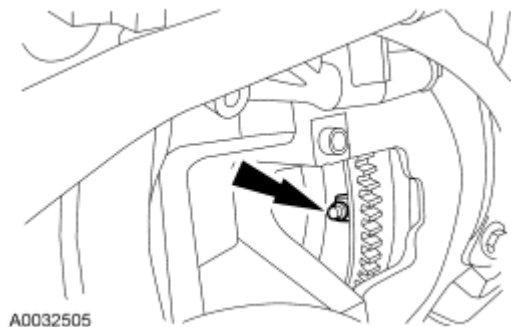

Fig. 525: Locating Torque Converter Nut
Courtesy of FORD MOTOR CO.

Vehicles equipped with a manual transmission

10. Connect the vehicle speed sensor (VSS) electrical connector.

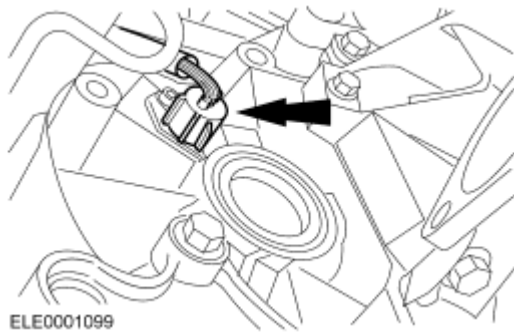

Fig. 526: Locating Vehicle Speed Sensor Electrical Connector
Courtesy of FORD MOTOR CO.

All vehicles

11. Using the lift table, position the engine and transaxle assembly in the vehicle.
12. Install the transaxle mount center nut.
 - Tighten to 133 Nm (98 lb-ft).

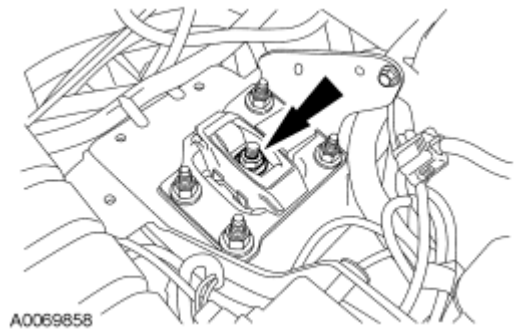

Fig. 527: Locating Transaxle Mount Center Nut
Courtesy of FORD MOTOR CO.

13. Install the 2 motor mount nuts.
 - Tighten to 90 Nm (66 lb-ft).

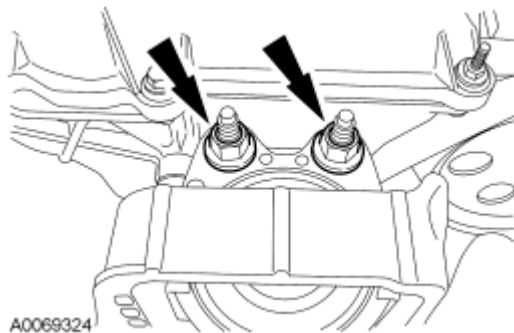

Fig. 528: Locating Engine Mount Nuts
Courtesy of FORD MOTOR CO.

14. Install the 2 oil pan-to-bellhousing bolts.
 - Tighten to 48 Nm (35 lb-ft).

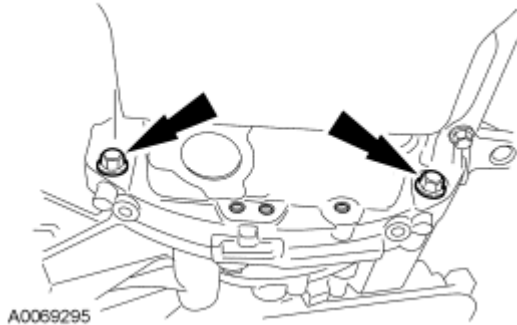

Fig. 529: Locating Oil Pan-To-Bellhousing Bolts
Courtesy of FORD MOTOR CO.

15. Install the 2 lower bellhousing-to-oil pan bolts.
 - Tighten to 48 Nm (35 lb-ft).



Fig. 530: Locating Lower Bellhousing Bolts
Courtesy of FORD MOTOR CO.

16. Install the starter motor isolator.

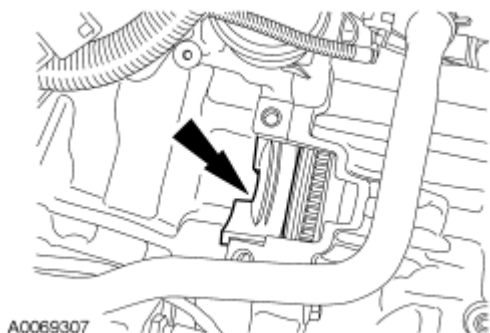

Fig. 531: Identifying Starter Motor Isolator
Courtesy of FORD MOTOR CO.

17. Install the starter motor and the 3 bolts.
 - Tighten to 25 Nm (18 lb-ft).

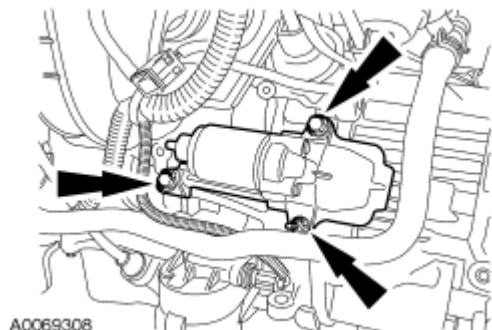

Fig. 532: Locating Starter Bolts
Courtesy of FORD MOTOR CO.

18. Install the transaxle roll restrictor and 2 bolts.
 - Tighten to 48 Nm (35 lb-ft).

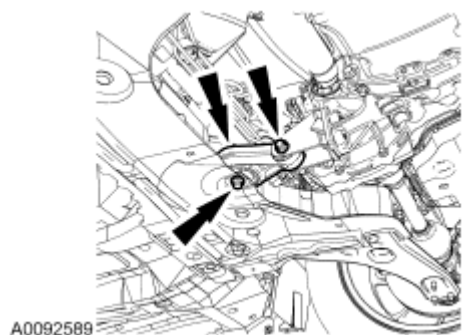

Fig. 533: Locating Transaxle Roll Restrictor And Bolts
Courtesy of FORD MOTOR CO.

NOTE: Install a new snap ring.

19. Install the LH front drive halfshaft.

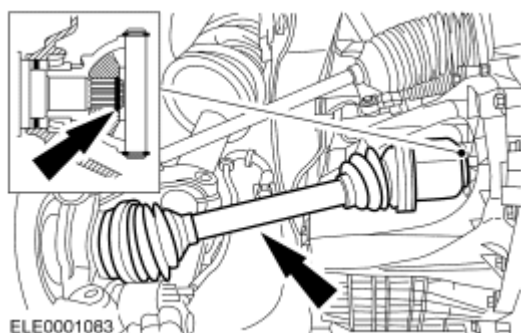

Fig. 534: Installing Halfshaft

Courtesy of FORD MOTOR CO.

20. Install the RH front halfshaft together with the intermediate shaft.

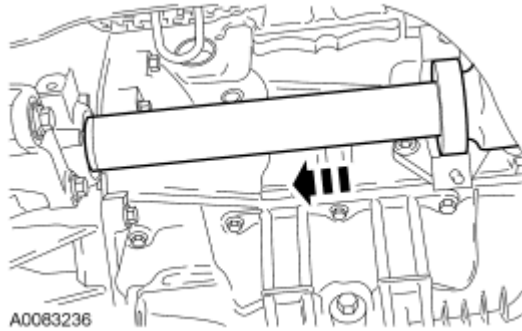

Fig. 535: Installing Halfshaft
Courtesy of FORD MOTOR CO.

21. Install the front drive intermediate shaft bearing mounting bracket.
- Tighten to 25 Nm (18 lb-ft).

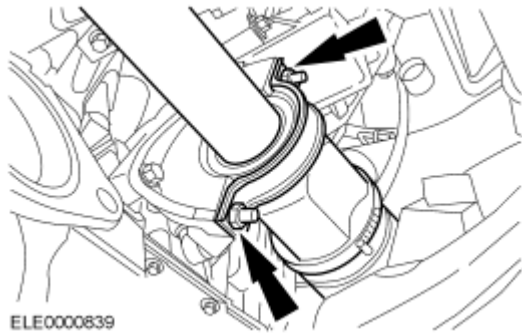

Fig. 536: Locating Intermediate Shaft Bearing Bracket Nuts
Courtesy of FORD MOTOR CO.

22. Install both of the lower control arms to the knuckles.
1. Connect the suspension arm ball joint.
 2. Install the bolt.
 - Tighten to 63 Nm (46 lb-ft).

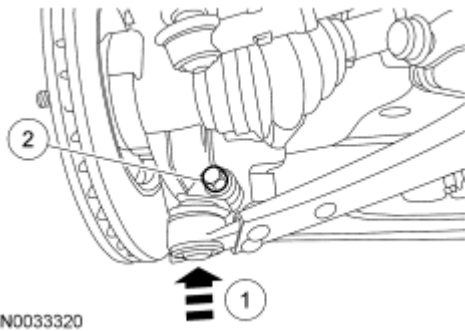

Fig. 537: Connecting Suspension Arm Ball Joint And Identifying Bolt
 Courtesy of FORD MOTOR CO.

23. Install both of the tie-rod ends to the knuckles.
 - Tighten to 40 Nm (30 lb-ft).

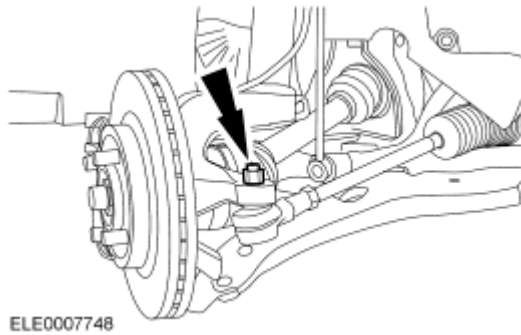

Fig. 538: Locating LH Tie-Rod End Nut
 Courtesy of FORD MOTOR CO.

24. Connect the stabilizer bar to the LH strut and install the nut.
 - Tighten to 55 Nm (41 lb-ft).

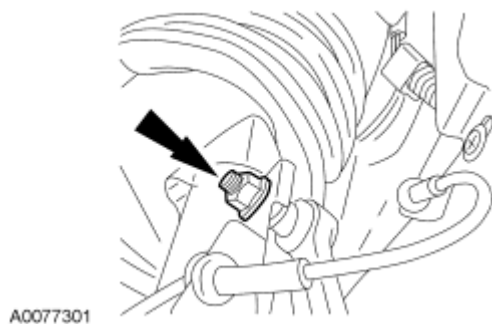

Fig. 539: Locating LH Stabilizer Bar Nut
 Courtesy of FORD MOTOR CO.

25. Tighten the LH strut and spring assembly top mount nuts.
 - Tighten to 30 Nm (22 lb-ft).

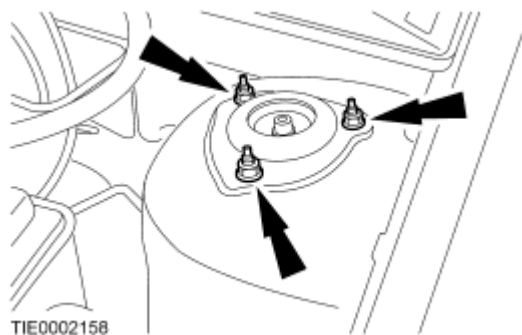

Fig. 540: Locating LH Strut And Spring Assembly Top Mount Nuts
 Courtesy of FORD MOTOR CO.

26. Install the caliper.
 1. Position the caliper and install the bolts.
 - Tighten to 28 Nm (21 lb-ft).
 2. Install the bolt covers.

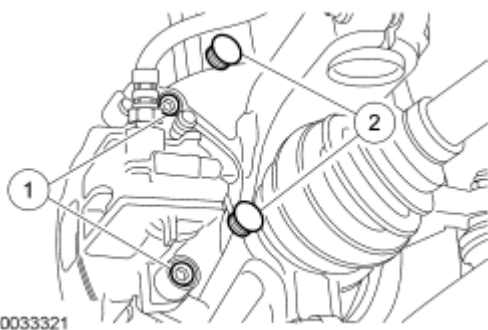

Fig. 541: Identifying Caliper Bolts And Bolt Covers
 Courtesy of FORD MOTOR CO.

27. Install the brake hose onto the support bracket.

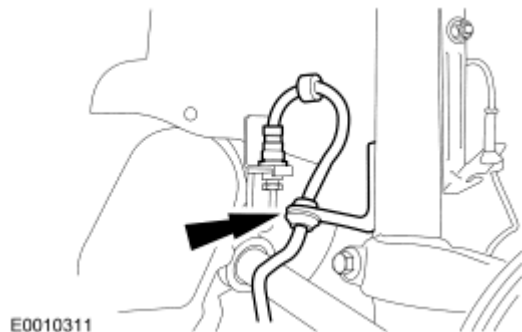

Fig. 542: Locating LH Brake Hose
 Courtesy of FORD MOTOR CO.

Vehicles equipped with air conditioning

NOTE: Install new O-ring seals.

28. Install the manifold and tube assembly onto the A/C compressor.
- Tighten to 21 Nm (15 lb-ft).

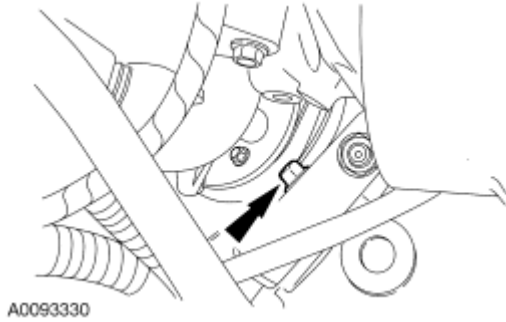

Fig. 543: Locating A/C Compressor Bolt
Courtesy of FORD MOTOR CO.

29. Install the A/C compressor and the 3 bolts.
- Tighten to 25 Nm (18 lb-ft).

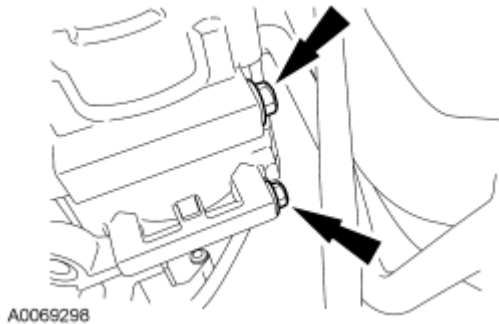

Fig. 544: Locating A/C Compressor Bolts
Courtesy of FORD MOTOR CO.

30. Connect the A/C compressor electrical connector.



Fig. 545: Locating A/C Compressor Electrical Connector

Courtesy of FORD MOTOR CO.

All vehicles

31. Install the power steering pressure (PSP) tube brackets and nuts.
 - Tighten to 11 Nm (8 lb-ft).

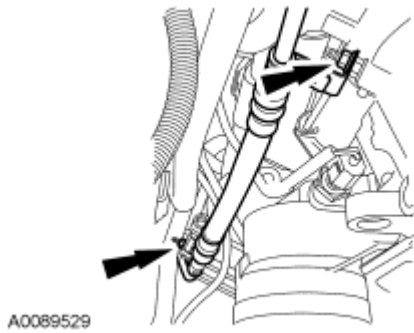

Fig. 546: Locating PSP Tube Bracket Nuts
Courtesy of FORD MOTOR CO.

32. Connect the starter motor electrical connections.
 - Tighten the small nut to 5 Nm (44 lb-in).
 - Tighten the large nut to 12 Nm (9 lb-ft).

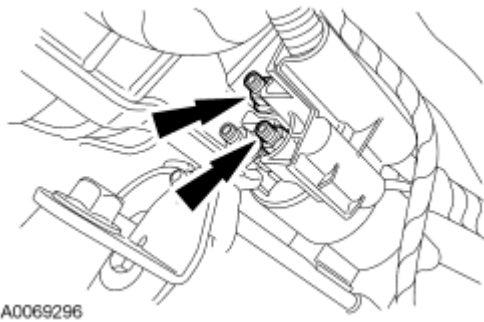
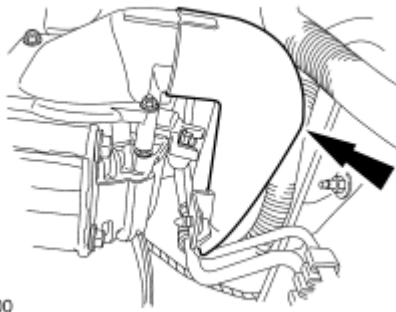

Fig. 547: Locating Starter Motor Electrical Terminals
Courtesy of FORD MOTOR CO.

33. Install the generator coolant pipe.



A0069300

Fig. 548: Locating Generator Cooling Pipe
Courtesy of FORD MOTOR CO.

34. Position the ground cable and install the bolt.
 - Tighten to 48 Nm (35 lb-ft).

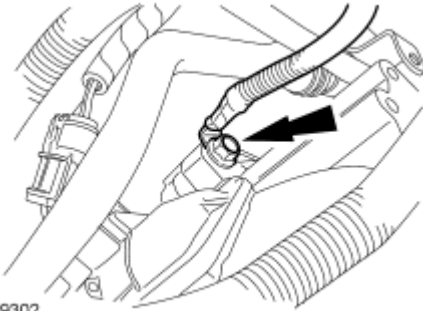

A0069302

Fig. 549: Locating Ground Cable Bolt
Courtesy of FORD MOTOR CO.

35. Connect the lower radiator hose.

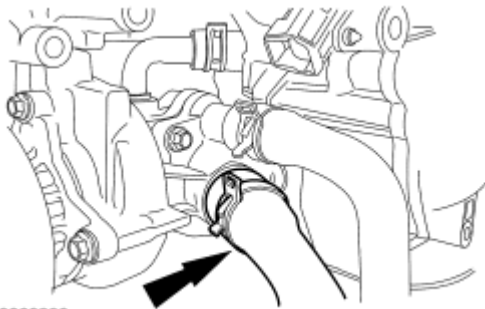

A0069299

Fig. 550: Locating Lower Radiator Hose
Courtesy of FORD MOTOR CO.

36. Install the cooling fan.

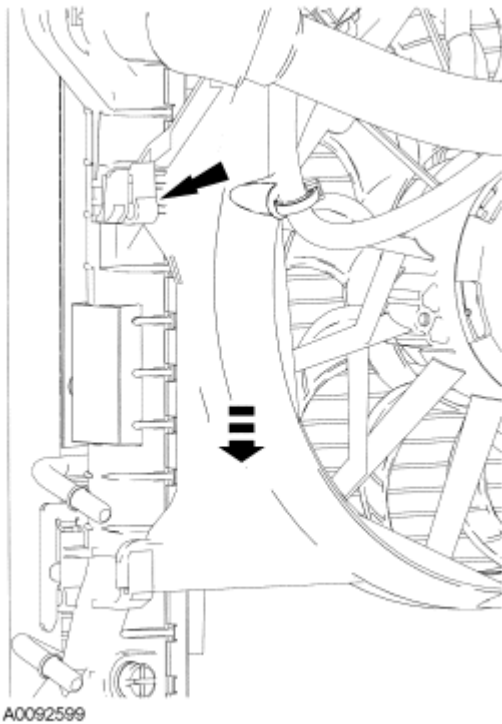

Fig. 551: Installing Cooling Fan
Courtesy of FORD MOTOR CO.

37. Connect the cooling fan electrical connectors.

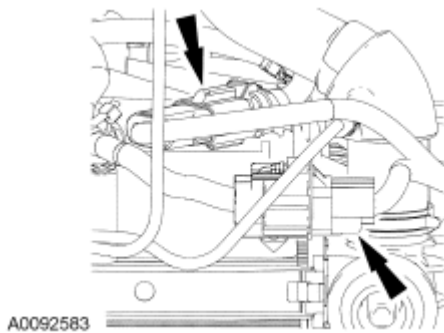

Fig. 552: Locating Cooling Fan Electrical Connectors
Courtesy of FORD MOTOR CO.

38. Install the coolant expansion tank and the bolt.
• Tighten to 10 Nm (89 lb-in).

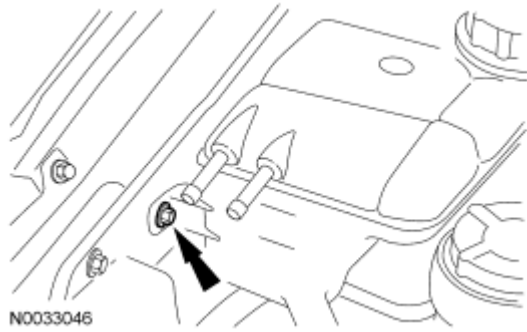

Fig. 553: Locating Coolant Expansion Tank Bolt
Courtesy of FORD MOTOR CO.

39. Connect the coolant hoses.

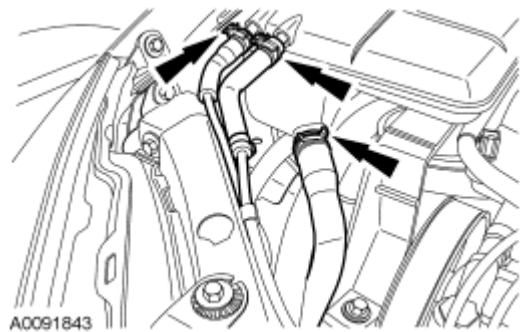

Fig. 554: Locating Coolant Hoses
Courtesy of FORD MOTOR CO.

40. Connect the heater hose to the "T" fitting.

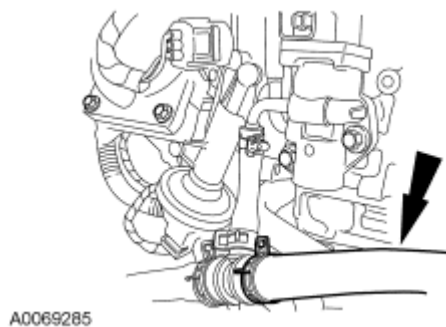

Fig. 555: Locating Heater Hose
Courtesy of FORD MOTOR CO.

Vehicles equipped with a 2.0L engine and automatic transmission

41. Connect the transmission cooler hoses.

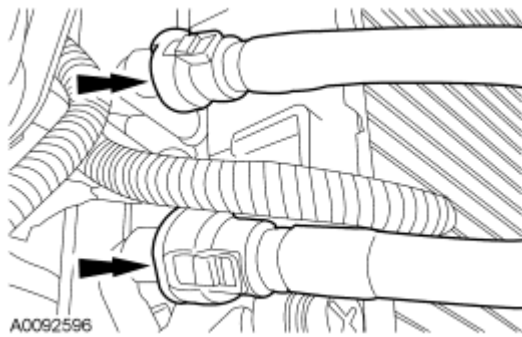

Fig. 556: Locating Transmission Cooler Hoses
Courtesy of FORD MOTOR CO.

- 42. Connect the transmission shifter cable.

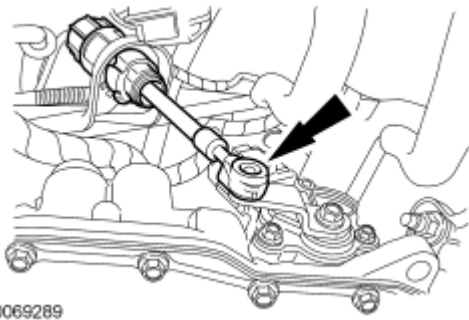

Fig. 557: Locating Transmission Shifter Cable
Courtesy of FORD MOTOR CO.

Vehicles equipped with a manual transmission

- 43. Connect the reversing lamp switch electrical connector.



Fig. 558: Locating Reversing Lamp Switch Electrical Connector
Courtesy of FORD MOTOR CO.

WARNING: Escaping brake fluid. Do not allow brake fluid to come into contact with the skin or the eyes. If brake fluid does come into contact with the skin or eyes, rinse the affected areas with water immediately.

Failure to follow these instructions may result in personal injury.

CAUTION: If brake fluid is spilled on the paintwork, the affected area must be immediately washed down with cold water.

44. Connect the clutch slave cylinder supply tube.
- Install the clip.

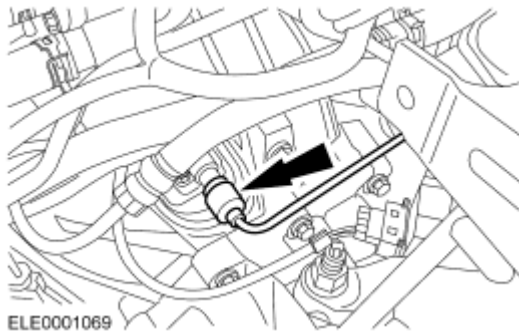

Fig. 559: Locating Clutch Slave Cylinder Supply Tube
Courtesy of FORD MOTOR CO.

NOTE: The shift cable abutment sleeve is colored white.

NOTE: The selector cable abutment sleeve is colored black.

45. Attach the transaxle cables to the bracket.
1. Attach the shifter cable to the bracket, turning the abutment sleeves counterclockwise to open. Position the cables into the metal holders.
 2. Attach the selector cable to the bracket, turning the abutment sleeves counterclockwise to open. Position the cables into the metal holders.

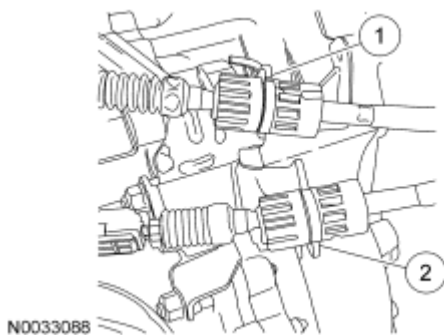

Fig. 560: Identifying Shifter And Selector Cable
Courtesy of FORD MOTOR CO.

46. Attach the gearshift cables.

1. Attach the shifter cable to the shift mass.
2. Attach the selector cable to the selector lever.

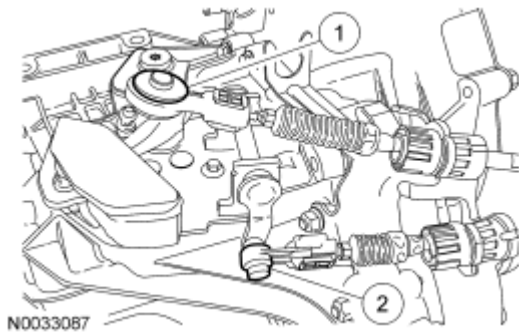

Fig. 561: Identifying Shifter Cable And Selector Cable
Courtesy of FORD MOTOR CO.

47. Adjust the gearshift cables and bleed the clutch system. For additional information, refer to **MANUAL TRANSAXLE/TRANSMISSION AND CLUTCH - GENERAL INFORMATION** article.

All vehicles

48. Connect the 3 main engine wiring harness connectors and attach the connectors to the bracket.

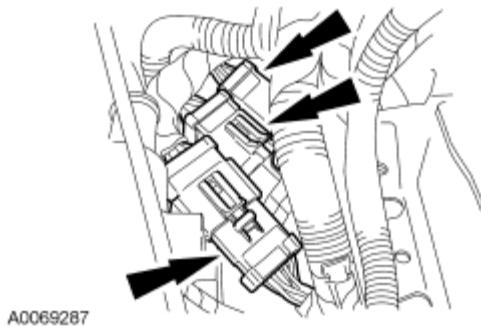

Fig. 562: Locating Main Engine Wiring Harness Electrical Connectors
Courtesy of FORD MOTOR CO.

49. Connect the power distribution harness eyelet and install the nut.
 - Tighten to 10 Nm (89 lb-in).



Fig. 563: Locating Power Distribution Wiring Harness Eyelet And Nut
Courtesy of FORD MOTOR CO.

50. Attach the wiring harness retainers.

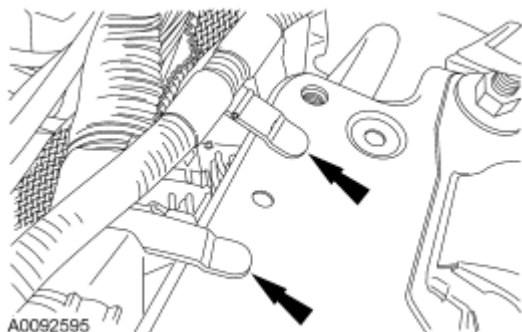

Fig. 564: Locating Positive Battery Cable Pin-Type Retainers
Courtesy of FORD MOTOR CO.

51. Connect the power distribution wiring harness electrical connector.

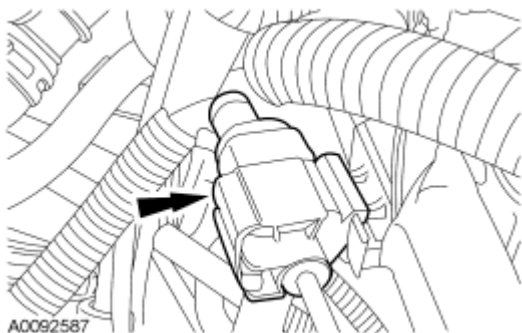

Fig. 565: Locating Power Distribution Wiring Harness Electrical Connector
Courtesy of FORD MOTOR CO.

52. Connect the fuel charging wiring harness electrical connector.

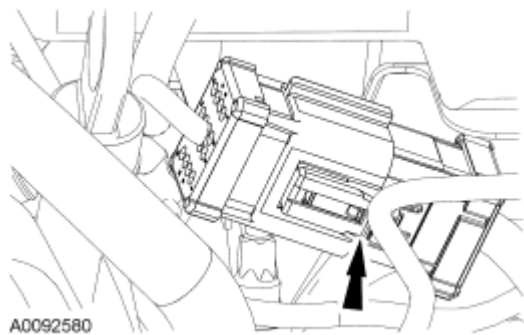

Fig. 566: Locating Fuel Charging Wiring Harness Electrical Connector
Courtesy of FORD MOTOR CO.

53. Connect the fuel charging wiring harness electrical connector and harness retainer.

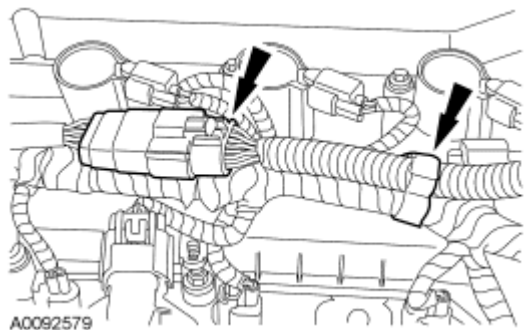

Fig. 567: Locating Fuel Charging Wiring Harness Electrical Connector And Harness Retainer
Courtesy of FORD MOTOR CO.

54. Install the ground eyelet and bolt.
- Tighten to 10 Nm (89 lb-in).

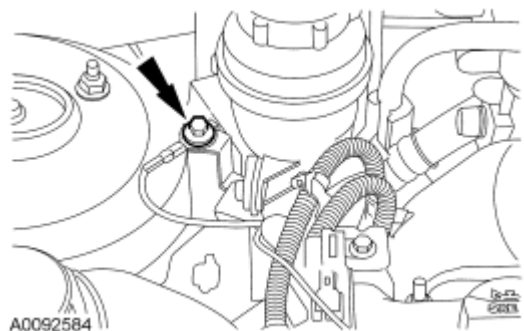
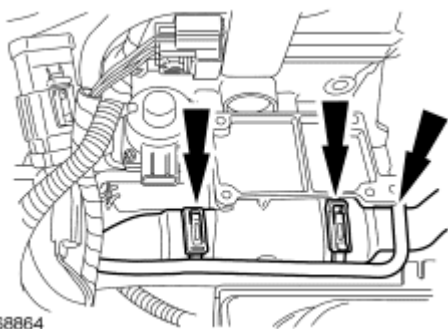

Fig. 568: Locating Ground Eyelet Bolt
Courtesy of FORD MOTOR CO.

55. Connect the upper radiator hose, the heater hose and the coolant vent hose to the coolant bypass.



A0068864

Fig. 569: Locating Upper Radiator Hose, Heater Hose And Coolant Vent Hose
Courtesy of FORD MOTOR CO.

56. Connect the exhaust gas recirculation (EGR) valve electrical connector.

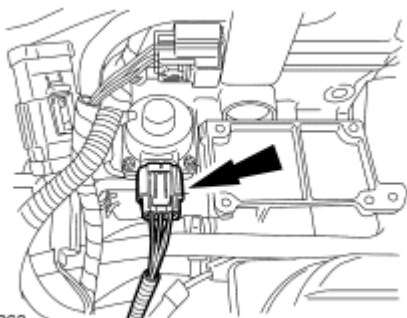

A0068863

Fig. 570: Locating Exhaust Gas Recirculation Valve Electrical Connector
Courtesy of FORD MOTOR CO.

57. Install the power brake booster vacuum tube into the quick release fitting.

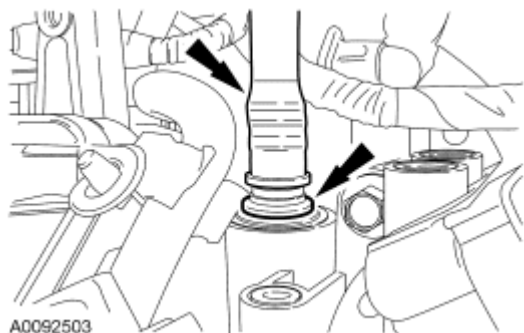

A0092503

Fig. 571: Locating Power Brake Booster Vacuum Tube And Quick Release Locking Ring
Courtesy of FORD MOTOR CO.

58. If equipped, connect the secondary air injection (AIR) vacuum regulator electrical connector.

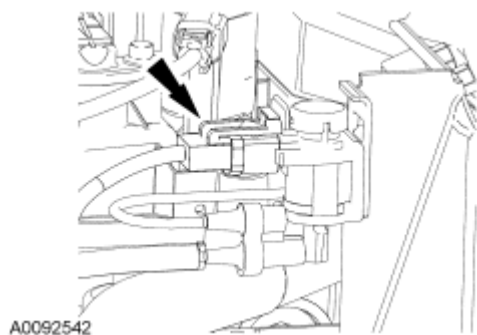

Fig. 572: Locating Air Vacuum Regulator Electrical Connector
Courtesy of FORD MOTOR CO.

59. If equipped, connect the AIR hose.

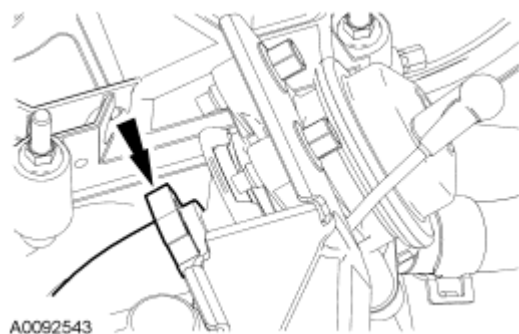

Fig. 573: Locating Air Hose
Courtesy of FORD MOTOR CO.

60. Connect the evaporative emissions tube. For additional information, refer to **FUEL SYSTEM - GENERAL INFORMATION** article.

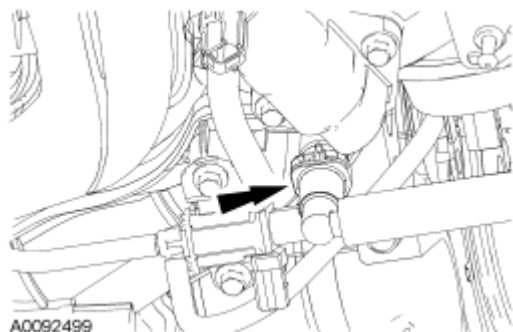

Fig. 574: Locating Evaporative Emissions Tube
Courtesy of FORD MOTOR CO.

61. Connect the fuel tube quick connect coupling onto the fuel rail. For additional information, refer to **FUEL SYSTEM - GENERAL INFORMATION** article.

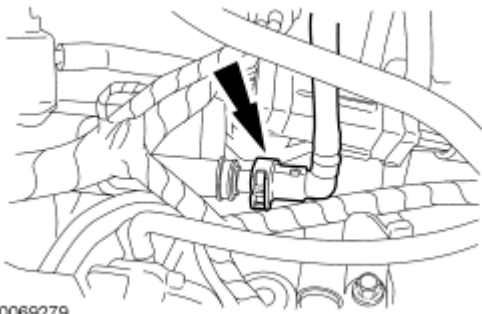

Fig. 575: Locating Fuel Tube Quick Connect Coupling
 Courtesy of FORD MOTOR CO.

62. Connect the accelerator cable and speed control cable (if equipped).
 1. Install the accelerator cable bracket and bolts.
 - Tighten to 10 Nm (89 lb-in).
 2. Connect the accelerator and speed control cable (if equipped) to the throttle body.

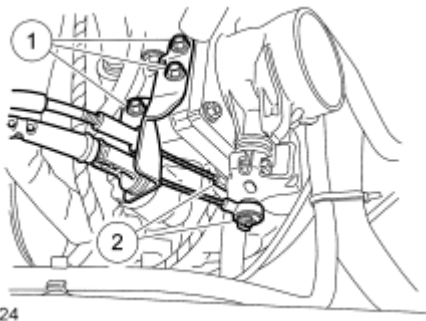

Fig. 576: Identifying Accelerator Cable Bracket Bolts, Accelerator And Speed Control Cable
 Courtesy of FORD MOTOR CO.

63. Install the accelerator control snow shield.
 - Position the snow shield and install the screw and pin-type retainer.
 - Tighten to 10 Nm (89 lb-in).
 - Attach the evaporative emissions hose pin-type retainer.

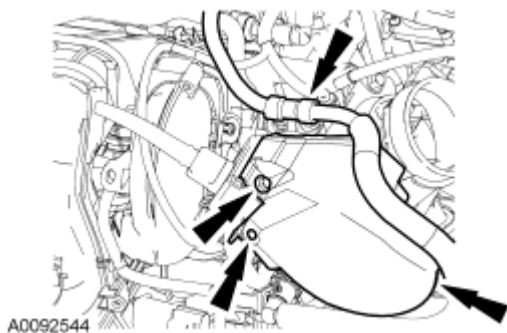

Fig. 577: Locating Accelerator Snow Shield, Screw And Pin-Type Retainers
 Courtesy of FORD MOTOR CO.

64. Install the air cleaner outlet pipe and air intake resonator into the grommets and install the bolt.

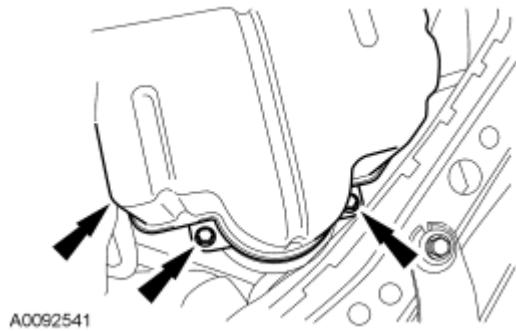

Fig. 578: Locating Air Cleaner Outlet Pipe, Air Intake Resonator And Bolt
 Courtesy of FORD MOTOR CO.

65. Tighten the air cleaner outlet pipe and connect the vent tube.

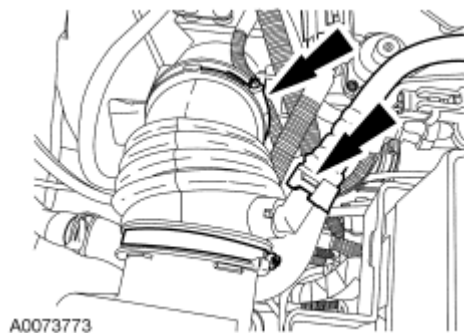

Fig. 579: Locating Air Cleaner Outlet Pipe And Vent Tube
 Courtesy of FORD MOTOR CO.

66. Clean and inspect the catalytic converter flange.
- Using a straightedge and a feeler gauge, place the straightedge across the catalytic converter flange surface and check for warping with the feeler gauge. If the reading is greater than the maximum specification, install a new catalytic converter, gasket and nuts.

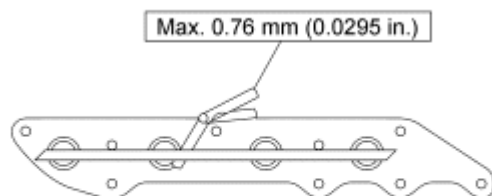

Fig. 580: Inspecting Catalytic Converter Flange W/Specs.
Courtesy of FORD MOTOR CO.

67. Using a new gasket and nuts, install the catalytic converter.
- Tighten in the sequence shown to 55 Nm (41 lb-ft).

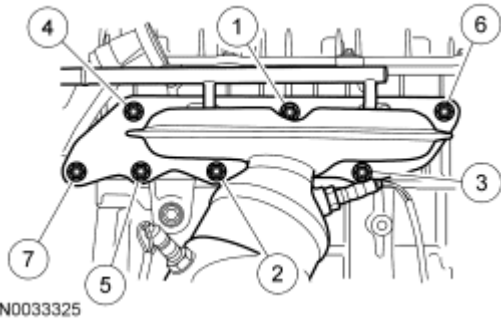

Fig. 581: Locating Catalytic Converter Nuts Tightening Sequence
Courtesy of FORD MOTOR CO.

68. If equipped, connect the AIR hose.



Fig. 582: Locating AIR Hose
Courtesy of FORD MOTOR CO.

69. If equipped, connect the upper exhaust sensor electrical connector and retainer.

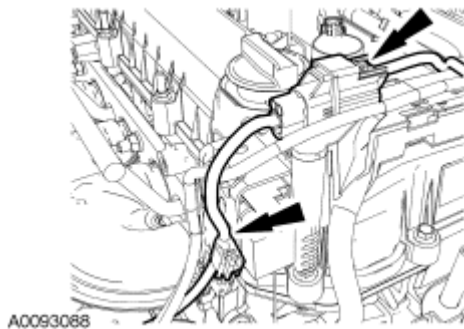

Fig. 583: Locating Electrical Connector And Wiring Retainer
Courtesy of FORD MOTOR CO.