

2011 Honda CR-V EX

2007-11 ENGINE Cylinder Head (K24Z1) - CR-V

2007-11 ENGINE

Cylinder Head (K24Z1) - CR-V

CYLINDER HEAD

SPECIAL TOOLS

Ref.No.	Tool Number	Description	Qty
①	07742-0010100	Valve Guide Driver, 5.35 x 9.7 mm	1
②	07746-0010400	Attachment, 52 x 55 mm	1
③	07749-0010000	Driver Handle, 15 x 135L	1
④	07757-PJ1010A	Valve Spring Compressor Attachment	1
⑤	07AAB-RJAA100	Crankshaft Pulley Holder	1
⑥	07AAB-RWCA120	Camshaft Lock Pin Set	1
⑦	07AAJ-PNAA101	Air Pressure Regulator	1
⑧	07HAH-PJ7A100	Valve Guide Reamer, 5.5 mm	1
⑨	07JAA-001020A	Socket, 19 mm	1
⑩	07JAB-001020B	Handle, 6-25-660L	1
⑪	07MAA-PR70110	Adjuster	1
⑫	07MAA-PR70120	Locknut Wrench	1
⑬	07PAD-0010000	Stem Seal Driver, 30 mm	1
⑭	07ZAJ-PNAA101	VTEC Air Adapter	2
⑮	07ZAJ-PNAA200	VTEC Air Stopper	1
⑯	07ZAJ-PNAA300	Air Joint Adapter	1

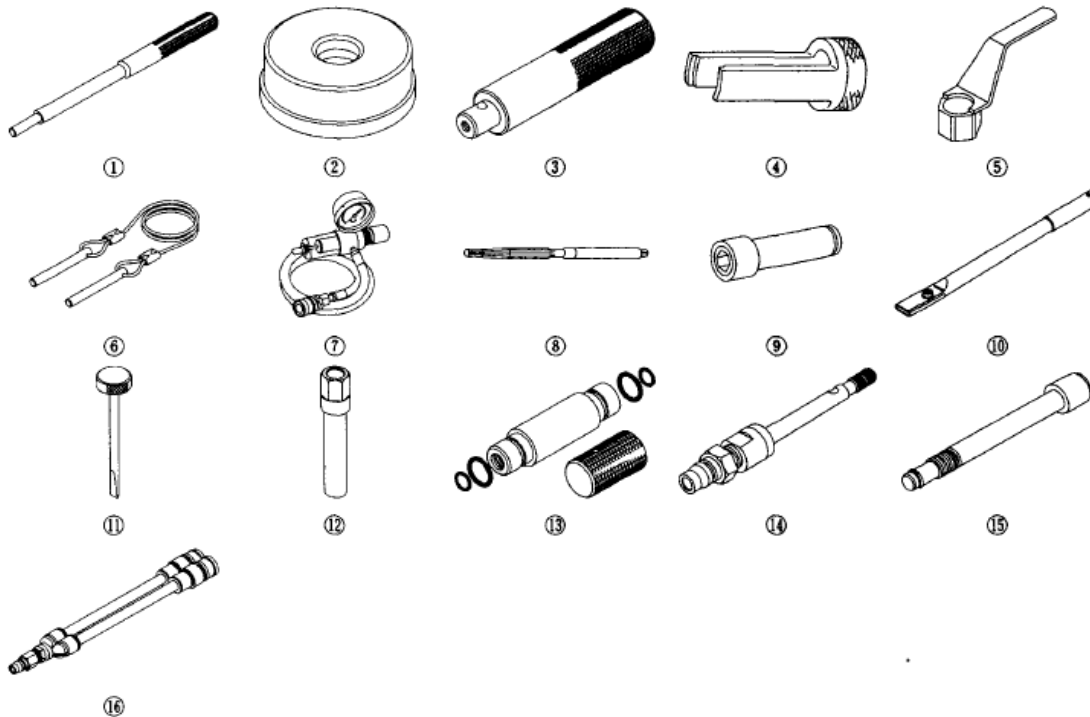

Fig. 1: Identifying Special Tools

Courtesy of AMERICAN HONDA MOTOR CO., INC.

COMPONENT LOCATION INDEX

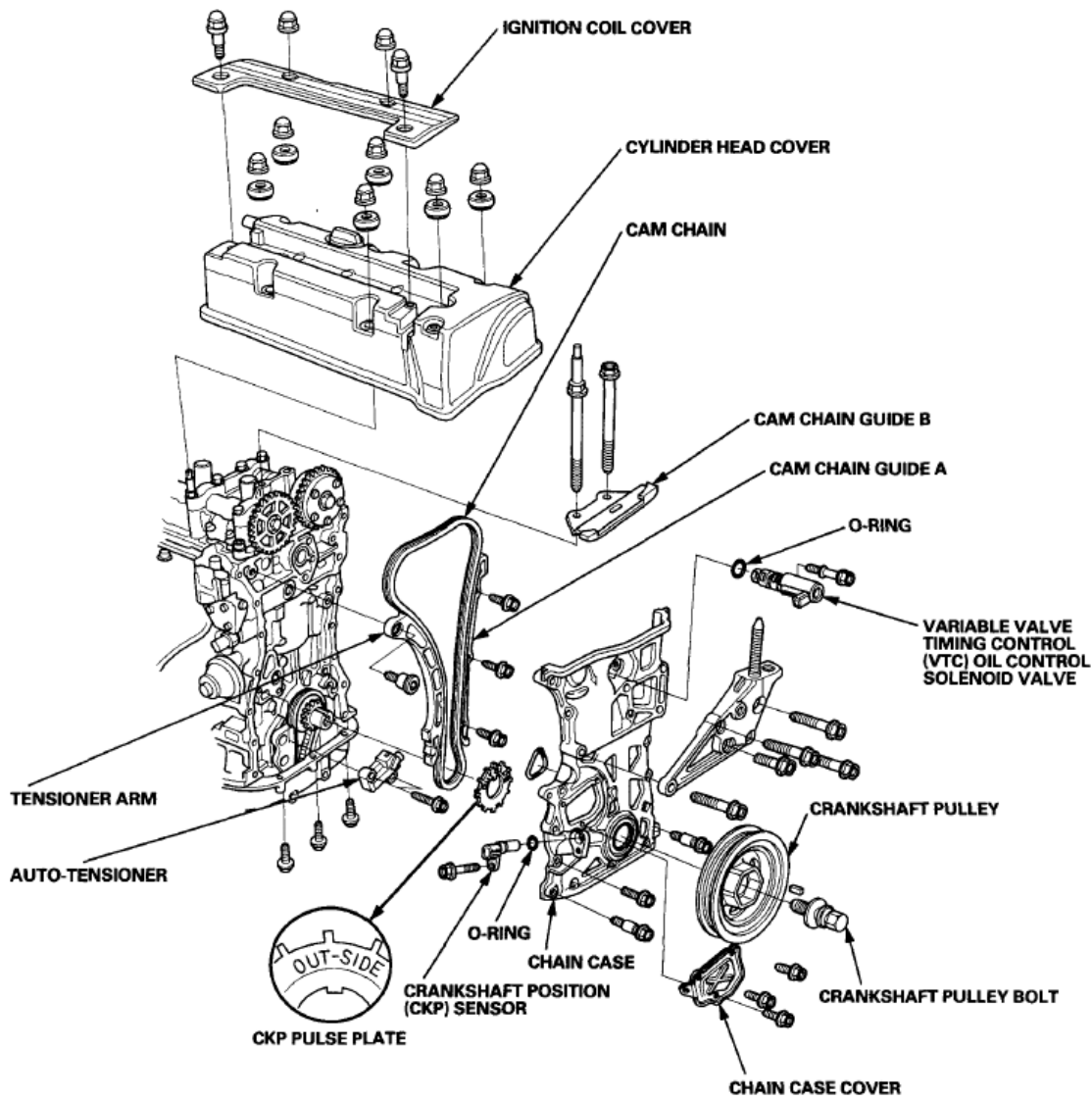

Fig. 2: Identifying Cylinder Head Component Location (1 Of 3)

Courtesy of AMERICAN HONDA MOTOR CO., INC.

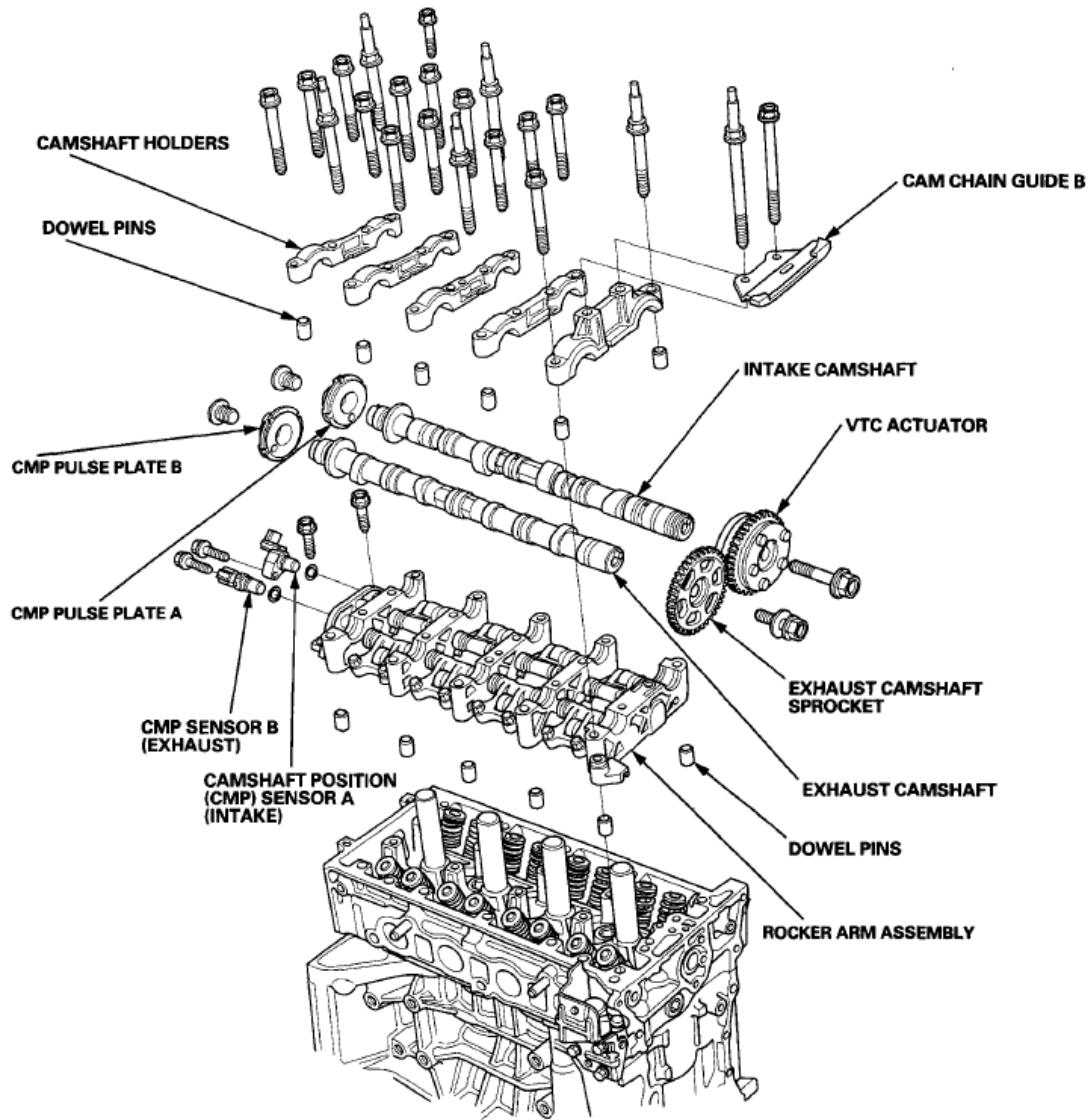

Fig. 3: Identifying Cylinder Head Component Location (2 Of 3)
Courtesy of AMERICAN HONDA MOTOR CO., INC.

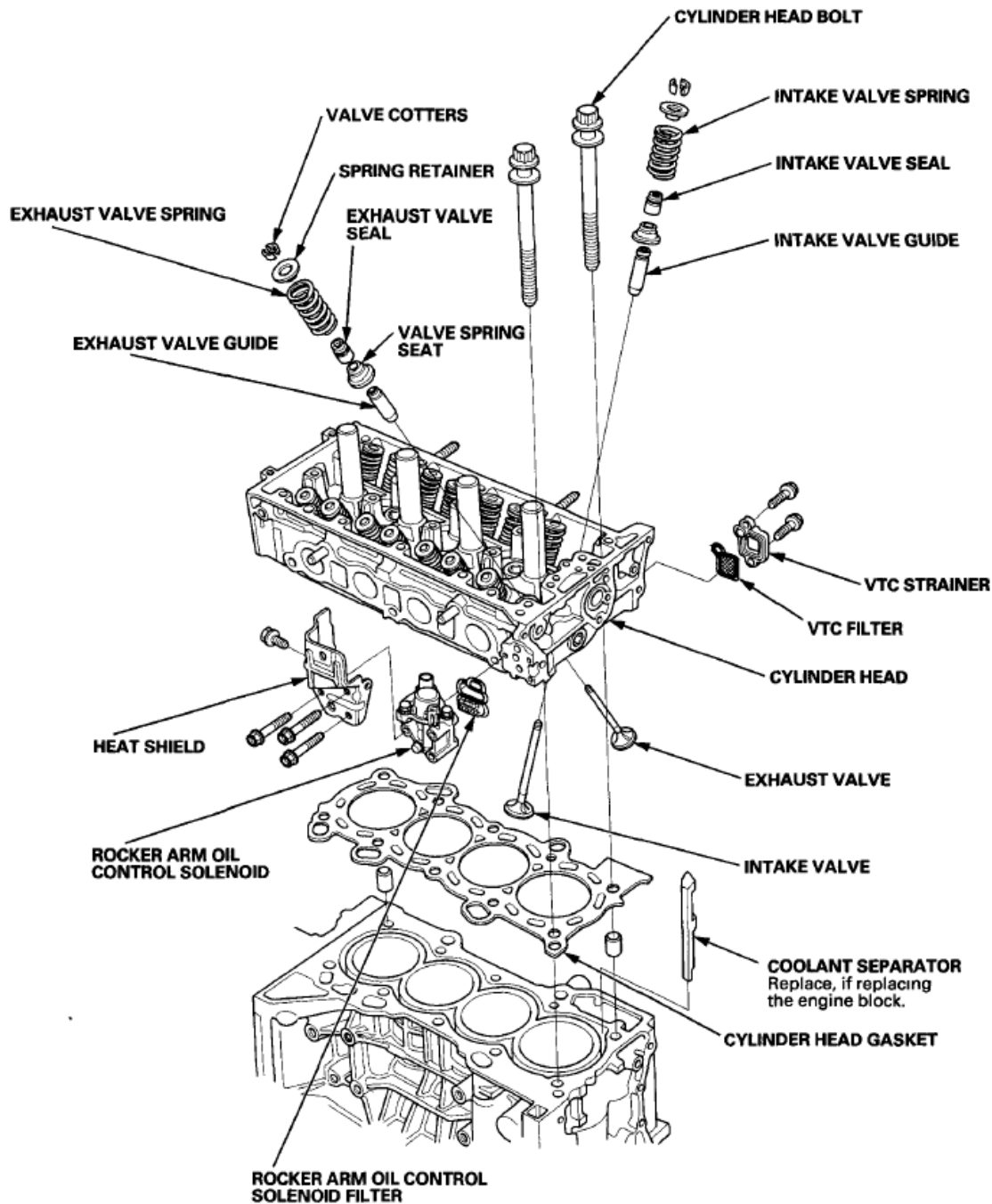

Fig. 4: Identifying Cylinder Head Component Location (3 Of 3)

Courtesy of AMERICAN HONDA MOTOR CO., INC.

ENGINE COMPRESSION INSPECTION

NOTE: After this inspection, you must reset the powertrain control module (PCM). Otherwise, the PCM will continue to stop the injectors from functioning.

1. Warm up the engine to normal operating temperature (cooling fan comes on).

2. Turn the ignition switch to LOCK (0).
3. Connect the HDS to the data link connector (DLC) (see step 2 under **HOW TO USE THE HDS (HONDA DIAGNOSTIC SYSTEM)**).
4. Turn the ignition switch to ON (II).
5. Make sure the HDS communicate, with the vehicle and the PCM. If it doesn't communicate, troubleshoot the DLC circuit (see **DLC CIRCUIT TROUBLESHOOTING**).
6. Select PGM-FI, INSPECTION, then ALL INJECTORS STOP function on the HDS.
7. Turn the ignition switch to LOCK (0).
8. Remove the four ignition coils and the four spark plugs (see **IGNITION COIL AND SPARK PLUG REMOVAL/INSTALLATION**).
9. Attach the compression gauge to the spark plug hole.

NOTE: Use a compression gauge with a connecting length (between the edge and the flange) of less than 23 mm (0.9 in).

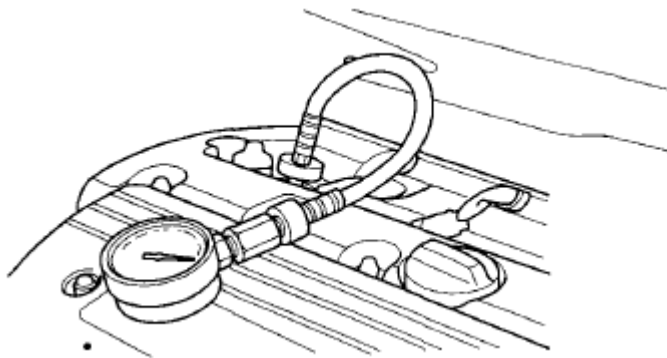

Fig. 5: Attaching Compression Gauge To Spark Plug Hole
Courtesy of AMERICAN HONDA MOTOR CO., INC.

10. Step on the accelerator pedal to open the throttle fully, then crank the engine with the starter motor and measure the compression.

Compression Pressure:

932 kPa (9.5 kgf/cm² , 135 psi)

11. Measure the compression on the remaining cylinders.

Maximum Variation:

196 kPa (2.0 kgf/cm² , 28 psi)

12. If the compression is not within specifications, check the following items, then remeasure the compression.

- Incorrect valve clearance
 - Valve deposits
 - Confirmation of cam timing
 - Damaged or worn cam lobes
 - Damaged or worn valves and seats
 - Damaged cylinder head gasket
 - Damaged or worn piston rings
 - Damaged or worn piston and cylinder bore
13. Remove the compression gauge from the spark plug hole.
 14. Install the four spark plugs and the four ignition coils (see **IGNITION COIL AND SPARK PLUG REMOVAL/INSTALLATION**).
 15. Select the PCM reset (see **PCM RESET**) to cancel the ALL INJECTORS STOP function on the HDS.

VTEC ROCKER ARM TEST

Special Tools Required

- Air Pressure Regulator 07AAJ-PNAA101
 - VTEC Air Adapter 07ZAJ-PNAA101 (2)
 - VTEC Air Stopper 07ZAJ-PNAA200
 - Air Joint Adapter 07ZAJ-PNAA300
1. Start the engine, let it run for 5 minutes, then turn the ignition switch to LOCK (0).
 2. Remove the cylinder head cover (see **CYLINDER HEAD COVER REMOVAL**).
 3. Set the No. 1 piston at top dead center (TDC) (see step 5).
 4. Verify that the intake primary rocker arm (A) moves independently of the intake secondary rocker arm (B).
 - If the intake primary rocker arm does not move, remove the primary and secondary rocker arms as an assembly and check that the pistons in the secondary and primary rocker arms move smoothly (see **ROCKER ARM AND SHAFT INSPECTION**). If any rocker arm needs replacing, replace the primary and secondary rocker arms as an assembly, then retest.
 - If the intake primary rocker arm moves freely, go to step 5.

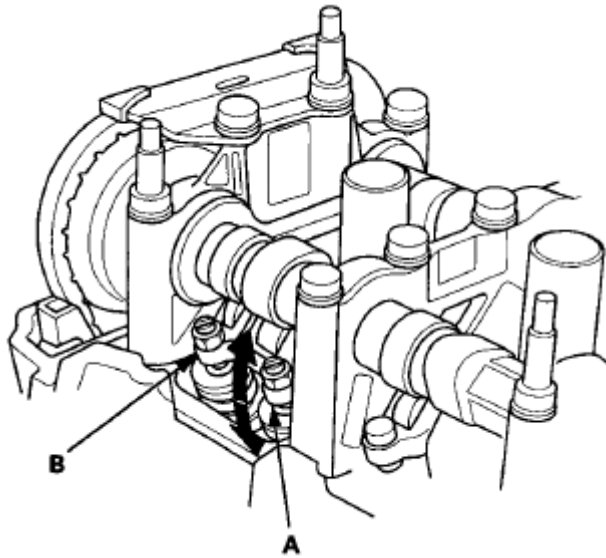

Fig. 6: Identifying Intake Primary Rocker Arm And Intake Secondary Rocker Arm
 Courtesy of AMERICAN HONDA MOTOR CO., INC.

5. Repeat step 4 on the remaining intake primary rocker arms with each piston at TDC. When all the primary rocker arms pass the test, go to step 6.
6. Check that the air pressure on the shop air compressor gauge indicates over 400 kPa (4.0 kgf/cm² , 57 psi).
7. Inspect the valve clearance (see **VALVE CLEARANCE ADJUSTMENT**).
8. Remove the sealing bolt (A) from the relief hole, and install the VTEC air stopper (B).

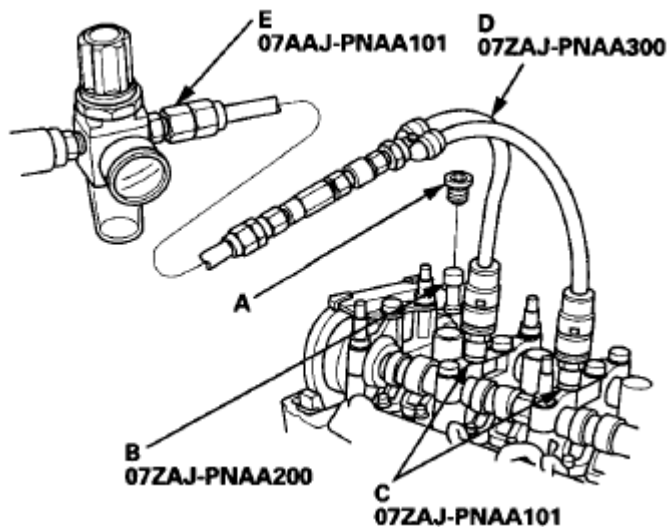

Fig. 7: Identifying Sealing Bolt And VTEC Air Stopper
 Courtesy of AMERICAN HONDA MOTOR CO., INC.

9. Remove the No. 2 and No. 3 camshaft holder bolts, and install the VTEC air adapters (C) finger-tight.

10. Connect the air joint adapter (D) and the air pressure regulator (E).
11. Loosen the valve on the regulator, and apply the specified air pressure.

Specified Air Pressure:

290 kPa (3.0 kgf/cm² , 42 psi)

NOTE: If the synchronizing piston does not move after applying air pressure; move the primary or secondary rocker arm up and down manually by rotating the crankshaft clockwise.

12. With the specified air pressure applied, move the intake primary rocker arm (A) for the No. 1 cylinder. The primary rocker arm and the secondary rocker arm (B) should move together.

If the intake secondary rocker arm does not move, remove the primary and secondary rocker arms as an assembly, and check that the pistons in the primary and secondary rocker arms move smoothly. If any rocker arm needs replacing, replace the primary and secondary rocker arms as an assembly, and test.

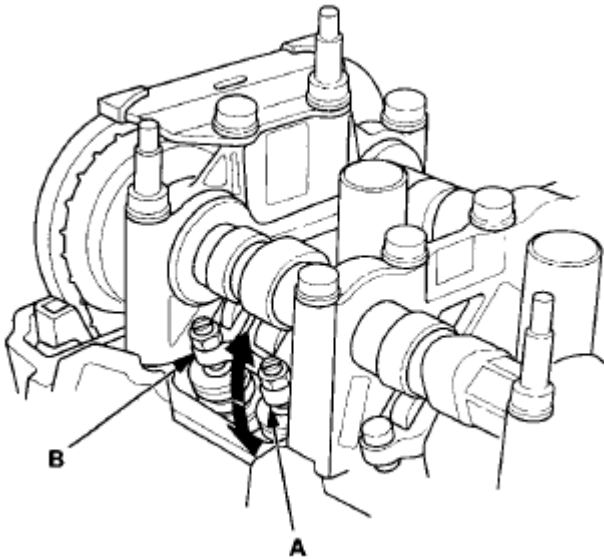

Fig. 8: Identifying Intake Primary Rocker Arm And Secondary Rocker Arm
 Courtesy of AMERICAN HONDA MOTOR CO., INC.

13. Remove the special tools.
14. Tighten the camshaft holder mounting bolts to 22 N.m (2.2 kgf.m, 16 lbf.ft).
15. Tighten the sealing bolt to 20 N.m (2.0 kgf.m, lbf.ft).
16. Install the cylinder head cover (see **CYLINDER HEAD COVER INSTALLATION**).

VTC ACTUATOR INSPECTION

1. Remove the cam chain (see **CAM CHAIN REMOVAL**).

2. Loosen the rocker arm adjusting screws (see step 2).
3. Remove the camshaft holder (see step 3).
4. Remove the intake camshaft.
5. Check that the variable valve timing control (VTC) actuator is locked by turning the VTC actuator counterclockwise. If not locked, turn the VTC actuator clockwise until it stops, then recheck it. If it is still not locked, replace the VTC actuator.
6. Seal the advance holes (A) in the No. 1 camshaft journal with tape and a wire tie.

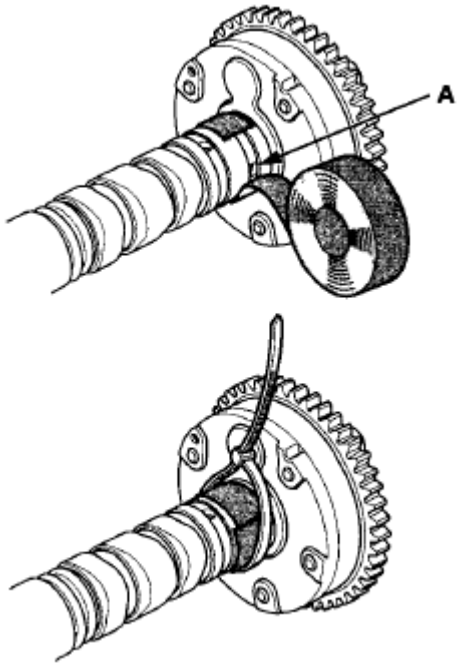

Fig. 9: Identifying No. 1 Camshaft Journal
Courtesy of AMERICAN HONDA MOTOR CO., INC.

7. Seal one of the advance holes (A) with tape.

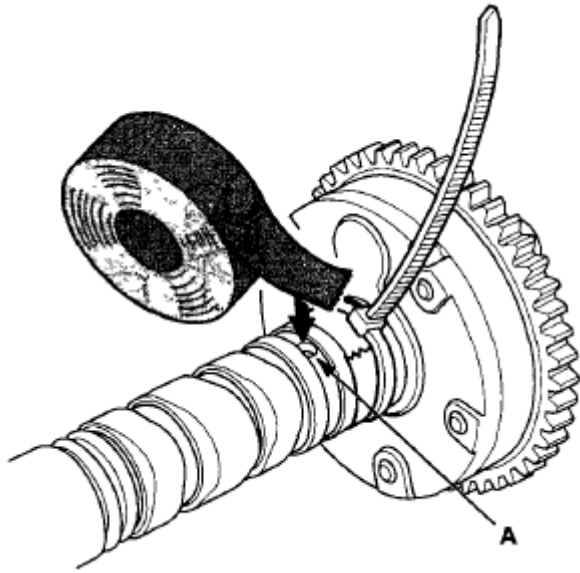

Fig. 10: Sealing Advance Holes With Tape
Courtesy of AMERICAN HONDA MOTOR CO., INC.

8. Apply air to the unsealed advance hole to release the lock.

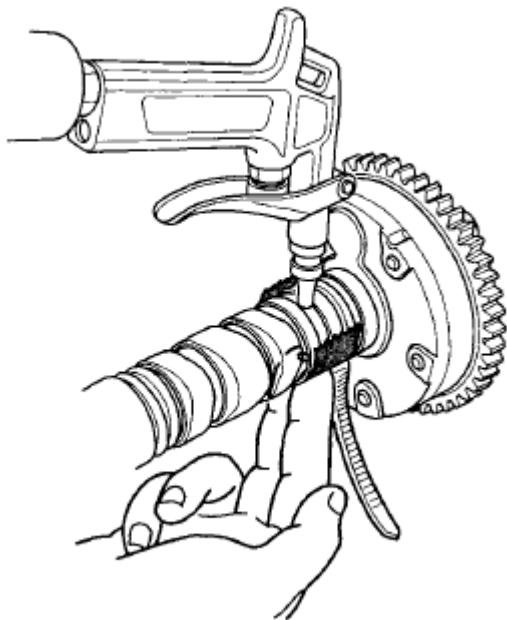

Fig. 11: Applying Air To Unsealed Advance Hole
Courtesy of AMERICAN HONDA MOTOR CO., INC.

9. Check that the VTC actuator moves smoothly. If the VTC actuator does not move smoothly, replace the VTC actuator.

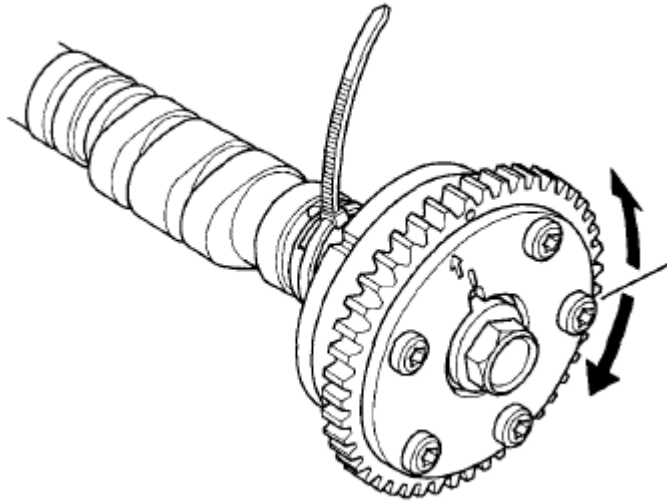

Fig. 12: Checking VTC Actuator
 Courtesy of AMERICAN HONDA MOTOR CO., INC.

10. Remove the wire tie, the tape, and any adhesive residue from the camshaft journal.
11. Make sure the punch marks on the VTC actuator and exhaust camshaft sprocket are facing up, then set the camshafts in the head (see step 6).
12. Set the camshaft holders and chain guide B in place (see step 7).
13. Tighten the camshaft holder bolts to the specified torque (see step 8).
14. Hold the camshaft and turn the VTC actuator clockwise until you hear it click. Make sure to lock the VTC actuator by turning it.
15. Install the cam chain (see **CAM CHAIN INSTALLATION**).
16. Adjust the valve clearance (see **VALVE CLEARANCE ADJUSTMENT**).

VALVE CLEARANCE ADJUSTMENT

Special Tools Required

- Adjuster 07MAA-PR70110
- Locknut Wrench 07MAA-PR70120

NOTE: Adjust the valves only when the cylinder head temperature is less than 100 °F (38 °C). Check the engine coolant temperature with the HDS if you are not sure.

1. Remove the cylinder head cover (see **CYLINDER HEAD COVER REMOVAL**).
2. Set the No. 1 piston at top dead center (TDC). The punch mark (A) on the variable valve timing control (VTC) actuator and the punch mark (B) on the exhaust camshaft sprocket should be at the top. Align the TDC marks (C) on the VTC actuator and the exhaust camshaft sprocket.

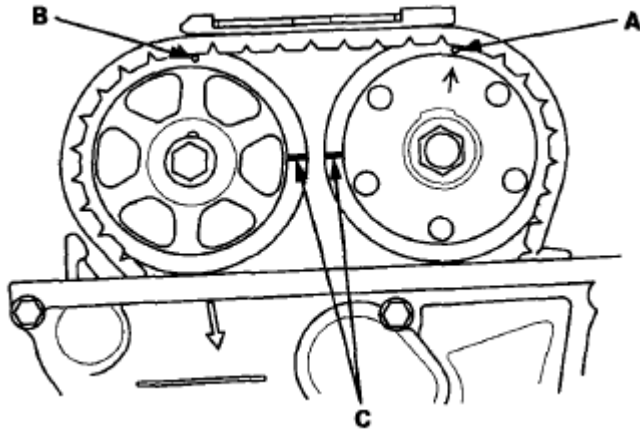

Fig. 13: Identifying Punch Mark On Variable Valve Timing Control Actuator
 Courtesy of AMERICAN HONDA MOTOR CO., INC.

3. Select the correct feeler gauge for the valves you're going to check.

Valve Clearance

Intake: 0.21-0.25 mm (0.008-0.010 in)

Exhaust: 0.28-0.32 mm (0.011-0.013 in)

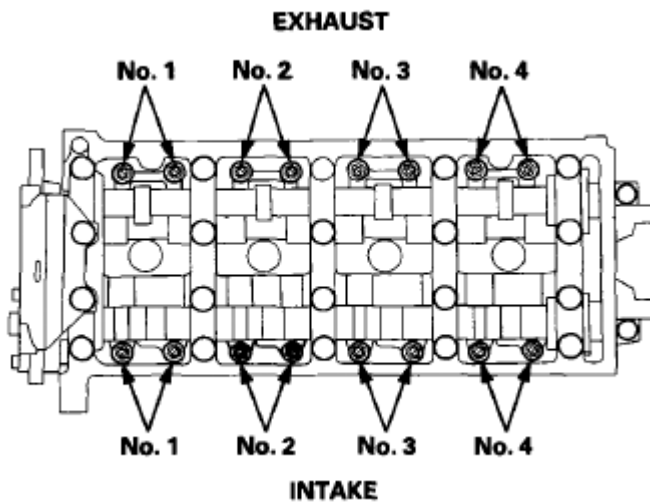

Fig. 14: Identifying Intake And Exhaust Bolts
 Courtesy of AMERICAN HONDA MOTOR CO., INC.

4. Insert the feeler gauge (A) between the adjusting screw (B) and the end of the valve stem, and slide it back and forth; you should feel a slight amount of drag.

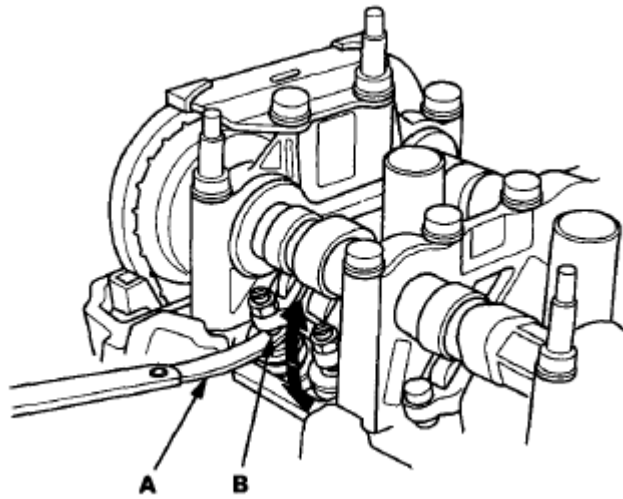

Fig. 15: Inserting Feeler Gauge Between Adjusting Screw And Valve Stem
Courtesy of AMERICAN HONDA MOTOR CO., INC.

5. If you feel too much or too little drag, loosen the locknut with the locknut wrench and adjuster, and turn the adjusting screw until the drag on the feeler gauge is correct.

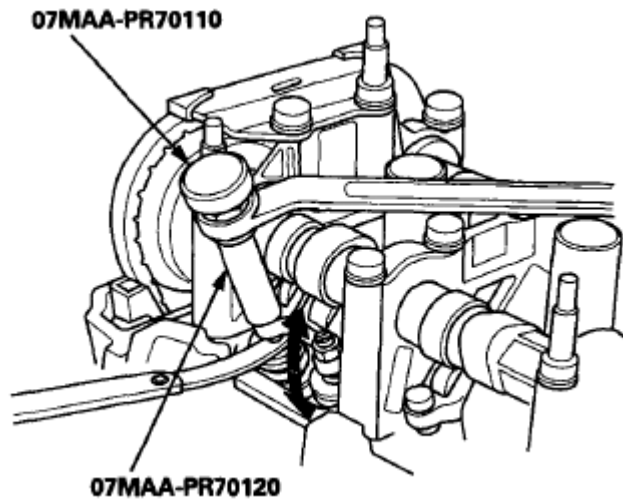

Fig. 16: Loosening Locknut With Locknut Wrench And Adjuster
Courtesy of AMERICAN HONDA MOTOR CO., INC.

6. Tighten the locknut to the specified torque and recheck the clearance. Repeat the adjustment if necessary.

Specified Torque

Intake:

7 x 0.75 mm

20 N.m (2.0 kgf.m, 14 lbf.ft)

Apply engine oil to the nut threads.

Exhaust:

7 x 0.75 mm

14 N.m (1.4 kgf.m, 10 lbf.ft)

Apply engine oil to the nut threads.

7. Rotate the crankshaft 180 ° clockwise (camshaft pulley turns 90 °).

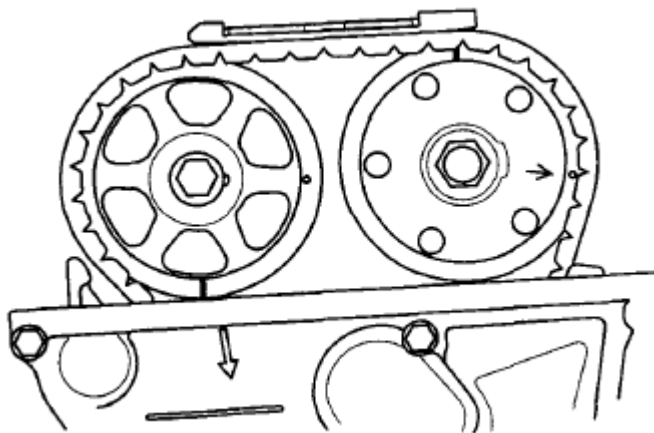

Fig. 17: Identifying Crankshaft Rotation Direction
Courtesy of AMERICAN HONDA MOTOR CO., INC.

8. Check and, if necessary, adjust the valve clearance on the No. 3 cylinder.
9. Rotate the crankshaft 180 ° clockwise (camshaft pulley turns 90 °).

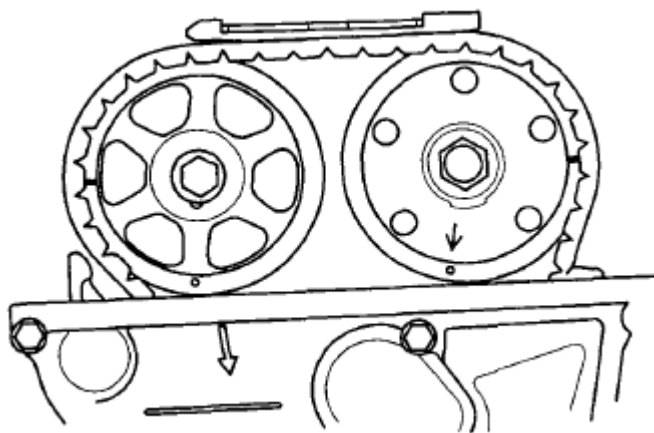

Fig. 18: Identifying Crankshaft Rotation Direction
Courtesy of AMERICAN HONDA MOTOR CO., INC.

10. Check and, if necessary, adjust the valve clearance on the No. 4 cylinder.
11. Rotate the crankshaft 180 ° clockwise (camshaft pulley turns 90 °).

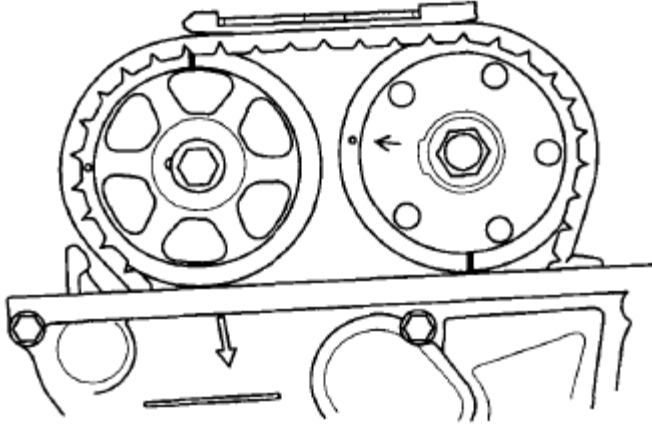

Fig. 19: Identifying Crankshaft Rotation Direction
Courtesy of AMERICAN HONDA MOTOR CO., INC.

12. Check and, if necessary, adjust the valve clearance on the No. 2 cylinder.
13. Install the cylinder head cover (see **CYLINDER HEAD COVER INSTALLATION**).

CRANKSHAFT PULLEY REMOVAL AND INSTALLATION

Special Tools Required

- Handle, 6-25-660L 07JAB-001020B
- Crankshaft Pulley Holder 07AAB-RJAA100
- Socket, 19 mm 07JAA-001020A or equivalent

Removal

1. Raise the vehicle on the lift, and remove the front wheels.
2. Remove the splash shield (see **FRONT SPLASH SHIELD REPLACEMENT**).
3. Remove the drive belt (see **DRIVE BELT REMOVAL/INSTALLATION**).
4. Hold the pulley with the handle (A) and the holder attachment (B).

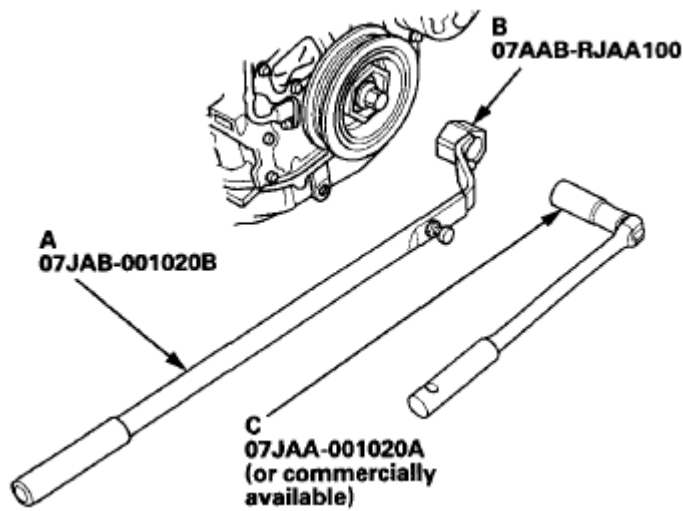

Fig. 20: Identifying Handle, Holder Attachment And Socket
 Courtesy of AMERICAN HONDA MOTOR CO., INC.

- Remove the bolt with a 19 mm socket (C) and breaker bar, then remove the crankshaft pulley.

Installation

- Clean the crankshaft pulley (A), crankshaft (B), bolt (C), and washer (D). Lubricate with new engine oil as shown.

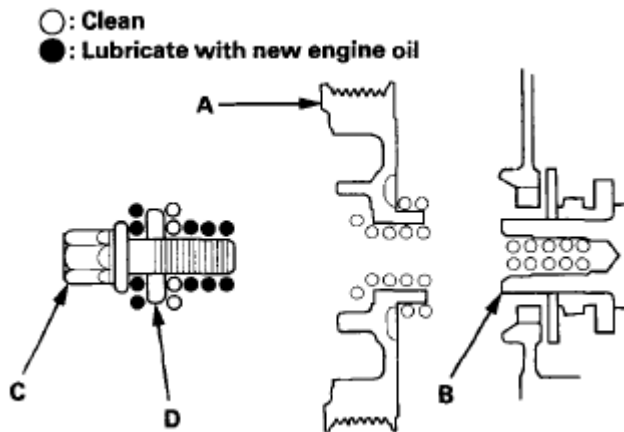

Fig. 21: Identifying Crankshaft Pulley, Crankshaft, Bolt And Washer
 Courtesy of AMERICAN HONDA MOTOR CO., INC.

- Install the crankshaft pulley, and hold the pulley with handle (A) and holder attachment (B).

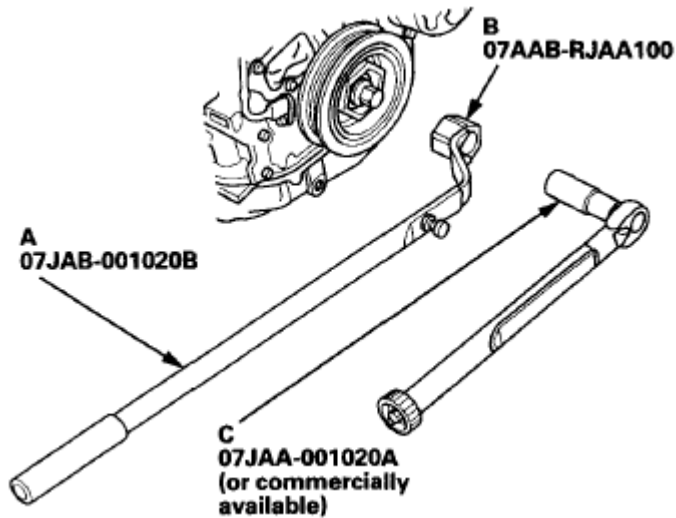

Fig. 22: Identifying Crankshaft Pulley, Handle And Holder Attachment
 Courtesy of AMERICAN HONDA MOTOR CO., INC.

3. Tighten the bolt to 49 N.m (5.0 kgf.m, 36 lbf.ft) with a torque wrench and 19 mm socket (C). Do not use an impact wrench.
4. Tighten the pulley bolt an additional 90 °.

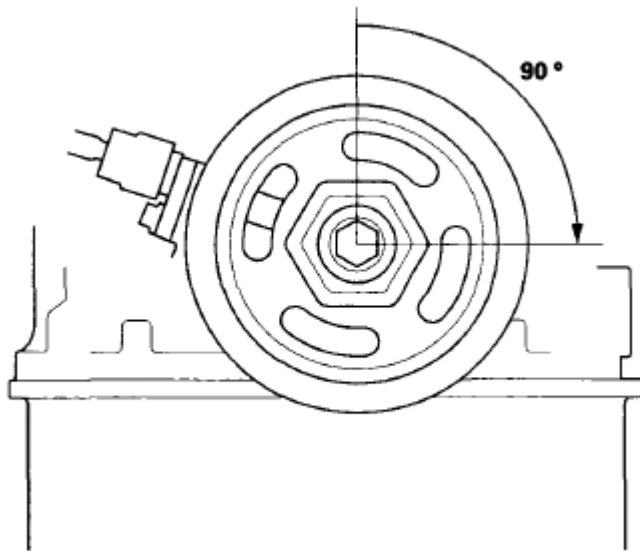

Fig. 23: Tightening Pulley Bolt
 Courtesy of AMERICAN HONDA MOTOR CO., INC.

5. Install the drive belt (see **DRIVE BELT REMOVAL/INSTALLATION**).
6. Install the splash shield (see **FRONT SPLASH SHIELD REPLACEMENT**).
7. Install the front wheels.

CAM CHAIN REMOVAL

NOTE: Keep the cam chain away from magnetic fields.

1. Raise the vehicle on the lift, and remove the front wheels.
2. Remove the splash shield (see **FRONT SPLASH SHIELD REPLACEMENT**).
3. Remove the drive belt (see **DRIVE BELT REMOVAL/INSTALLATION**).
4. Remove the cylinder head cover (see **CYLINDER HEAD COVER REMOVAL**).
5. Set the No. 1 piston at top dead center (TDC). The punch mark (A) on the variable valve timing control (VTC) actuator and the punch mark (B) on the exhaust camshaft sprocket should be at the top. Align the TDC marks (C) on the VTC actuator and exhaust camshaft sprocket.

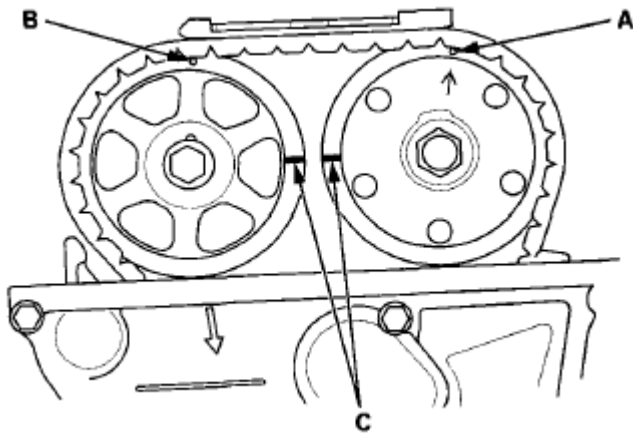

Fig. 24: Identifying TDC Marks On VTC Actuator And Exhaust Camshaft Sprocket
 Courtesy of AMERICAN HONDA MOTOR CO., INC.

6. Disconnect the crankshaft position (CKP) sensor connector (A) and the VTC oil control solenoid valve connector (B).

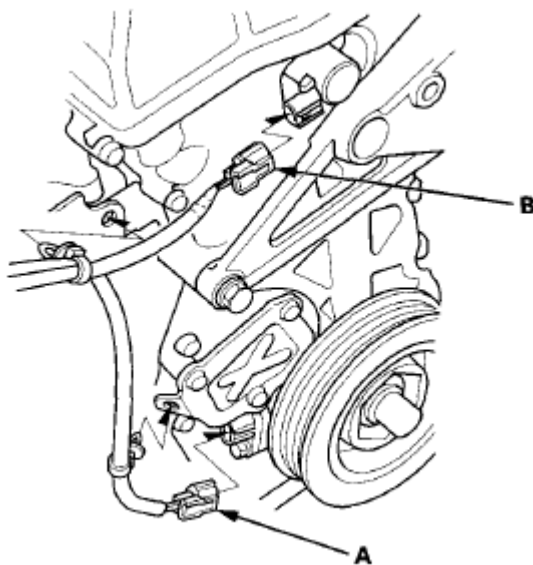

Fig. 25: Identifying Crankshaft Position Sensor Connector And VTC Oil Control Solenoid Valve Connector

Courtesy of AMERICAN HONDA MOTOR CO., INC.

7. Remove the VTC oil control solenoid valve (see **VTC OIL CONTROL SOLENOID VALVE REMOVAL/TEST/INSTALLATION**).
8. Remove the crankshaft pulley (see **CRANKSHAFT PULLEY REMOVAL AND INSTALLATION**).
9. Support the engine with a jack and a wood block under the oil pan.
10. Remove the upper torque rod.

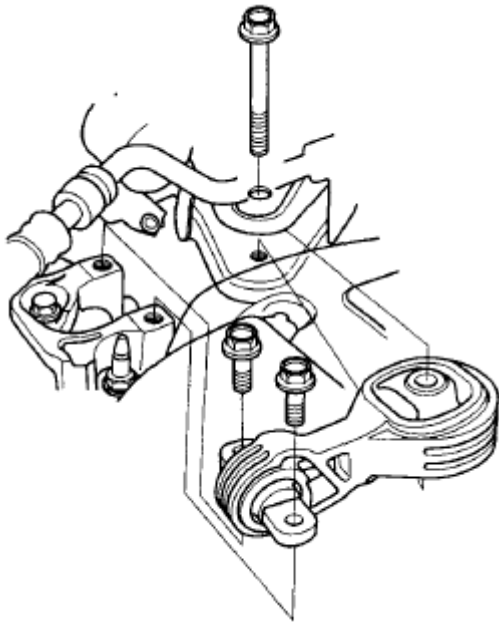

Fig. 26: Identifying Side Engine Mount Bracket

Courtesy of AMERICAN HONDA MOTOR CO., INC.

11. Remove the ground cable (A), then remove the side engine mount bracket (B).

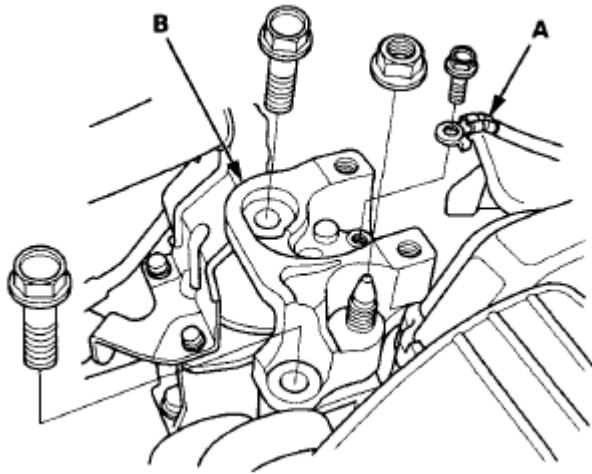

Fig. 27: Identifying Side Engine Mount Bracket And Ground Cable
Courtesy of AMERICAN HONDA MOTOR CO., INC.

12. Remove the side engine mount bracket mounting bolts.

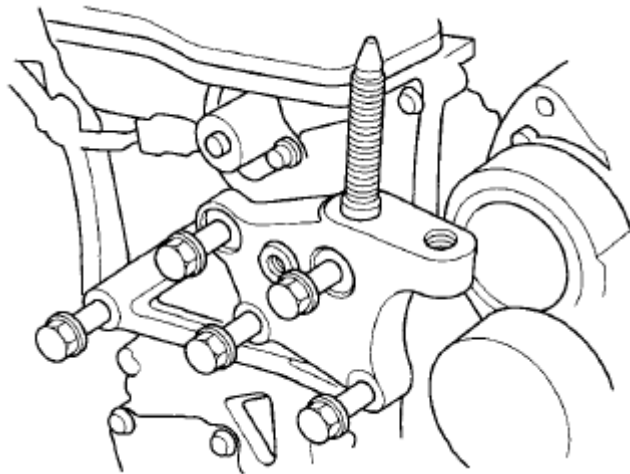

Fig. 28: Identifying Side Engine Mount Bracket Mounting Bolts
Courtesy of AMERICAN HONDA MOTOR CO., INC.

13. Remove the cam chain case (A) and the side engine mount bracket (B).

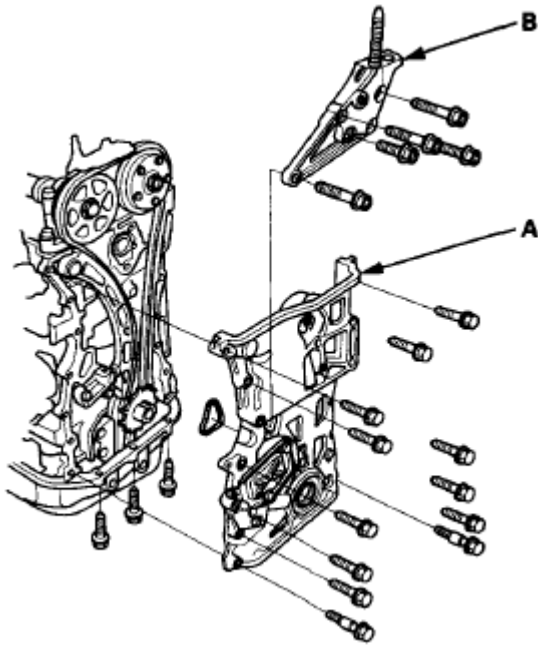

Fig. 29: Identifying Cam Chain Case And Side Engine Mount Bracket
 Courtesy of AMERICAN HONDA MOTOR CO., INC.

14. Loosely install the crankshaft pulley.
15. Turn the crankshaft counterclockwise to compress the auto-tensioner.

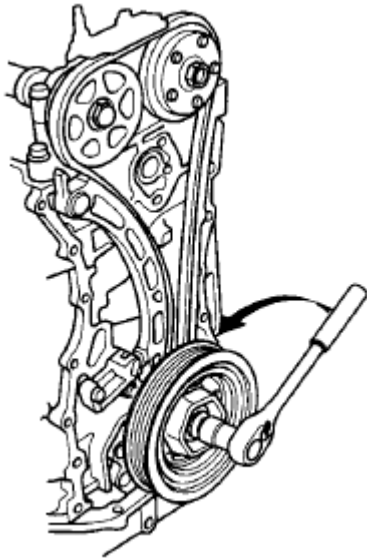

Fig. 30: Turning Crankshaft Counterclockwise
 Courtesy of AMERICAN HONDA MOTOR CO., INC.

16. Align the holes on the lock (A) and the auto-tensioner (B), then insert a 1.2 mm (0.05 in) diameter pin or lock pin (P/N 14511-PNA-003) (C) into the holes. Turn the crankshaft clockwise to secure the pin.

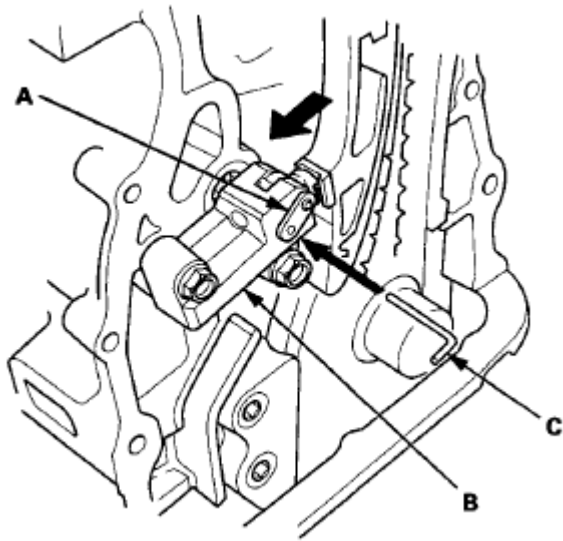

Fig. 31: Aligning Holes On Lock And Auto-Tensioner
Courtesy of AMERICAN HONDA MOTOR CO., INC.

17. Remove the auto-tensioner.

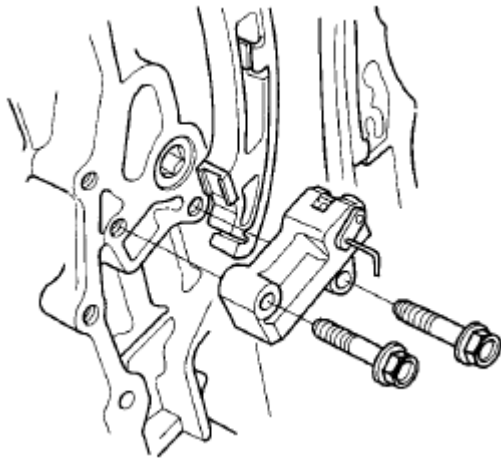

Fig. 32: Identifying Auto-Tensioner
Courtesy of AMERICAN HONDA MOTOR CO., INC.

18. Remove cam chain guide B.

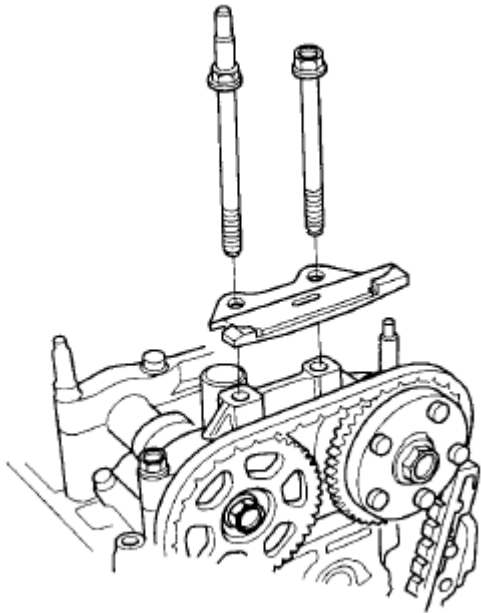

Fig. 33: Identifying Cam Chain Guide
Courtesy of AMERICAN HONDA MOTOR CO., INC.

19. Remove cam chain guide A and the tensioner arm (B).

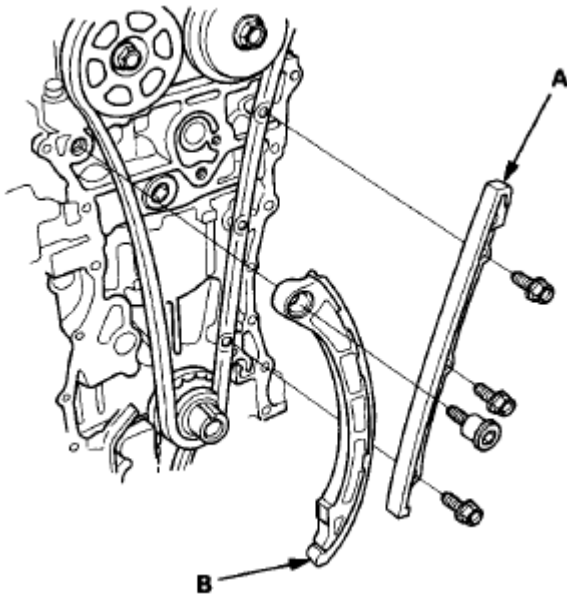

Fig. 34: Identifying Cam Chain Guide And Tensioner Arm
Courtesy of AMERICAN HONDA MOTOR CO., INC.

20. Remove the cam chain.

CAM CHAIN INSTALLATION

Special Tools Required

Camshaft Lock Pin Set 07AAB-RWCA120

NOTE:

- Keep the cam chain away from magnetic fields.
- Before starting this procedure, check that the variable valve timing control (VTC) actuator is locked by turning the VTC actuator counterclockwise. If not locked, turn the VTC actuator clockwise until it stops, then recheck it. If it is still not locked, replace the VTC actuator.

1. Set the crankshaft to top dead center (TDC). Align the TDC mark (A) on the crankshaft sprocket with the pointer (B) on the engine block.

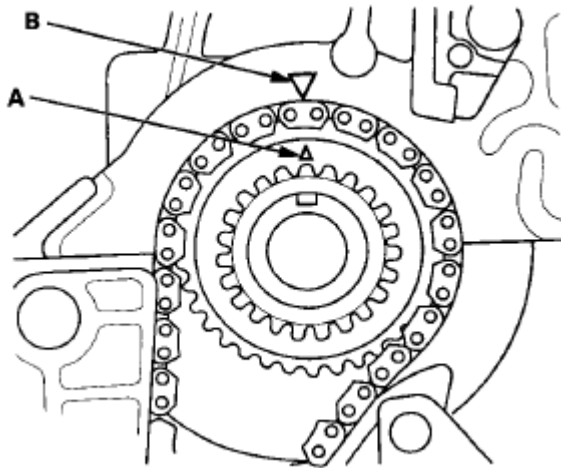

Fig. 35: Identifying Cam Chain Guide And Tensioner Arm
Courtesy of AMERICAN HONDA MOTOR CO., INC.

2. Set the camshafts to TDC. The punch mark (A) on the VTC actuator and the punch mark (B) on the exhaust camshaft sprocket should be at the top. Align the TDC marks (C) on the VTC actuator and exhaust camshaft sprocket.

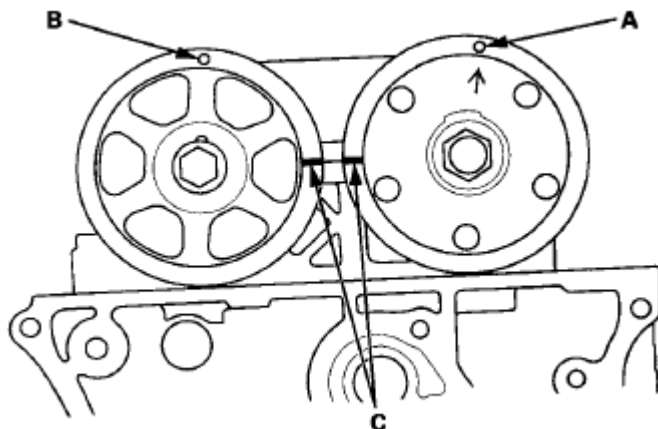

Fig. 36: Identifying Punch Mark On Exhaust Camshaft Sprocket
 Courtesy of AMERICAN HONDA MOTOR CO., INC.

- To hold the intake camshaft, insert the a camshaft lock pin (07AAB-RWCA120) (A) into the maintenance hole in the camshaft position (CMP) pulse plate A (B) and through the No. 5 rocker shaft holder (C).

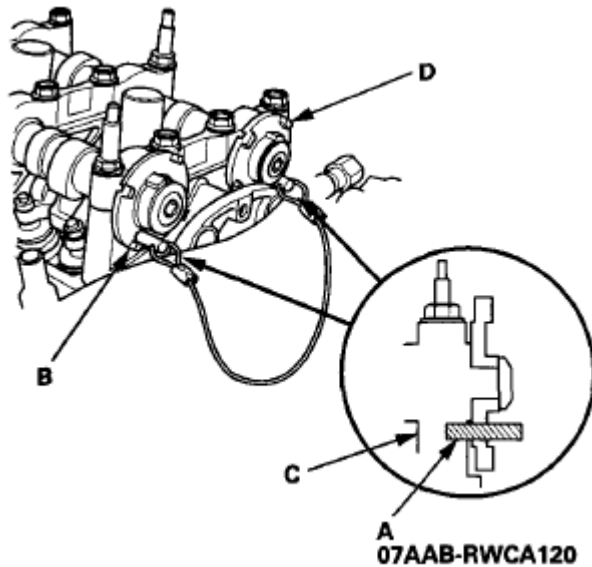

Fig. 37: Identifying Camshaft Position Pulse Plate And Rocker Shaft Holder
 Courtesy of AMERICAN HONDA MOTOR CO., INC.

- To hold the exhaust camshaft, insert the other camshaft lock pin (A) into the maintenance hole in the CMP pulse plate B (D) and through No. 5 rocker shaft holder (C).
- Install the cam chain on the crankshaft sprocket with the colored link plate (A) aligned with the mark (B) on the crankshaft sprocket.

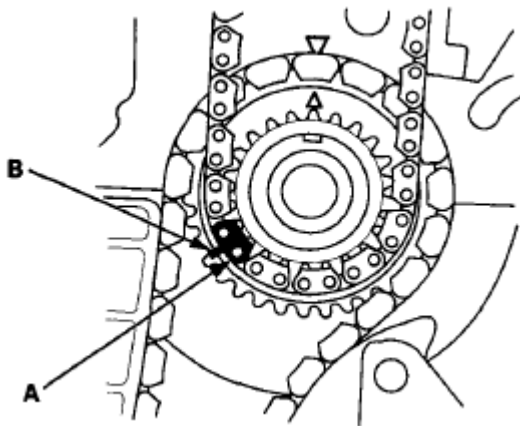

Fig. 38: Identifying Mark On Crankshaft Sprocket
 Courtesy of AMERICAN HONDA MOTOR CO., INC.

- Install the cam chain on the VTC actuator and the exhaust camshaft sprocket with the punch marks (A)

aligned with the center of the two colored link plates (B).

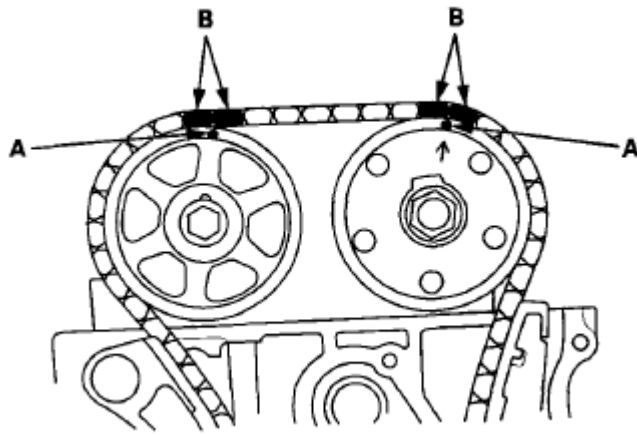

Fig. 39: Installing Cam Chain On VTC Actuator
Courtesy of AMERICAN HONDA MOTOR CO., INC.

7. Apply new engine oil to the threads of the cam chain tensioner mounting bolt.

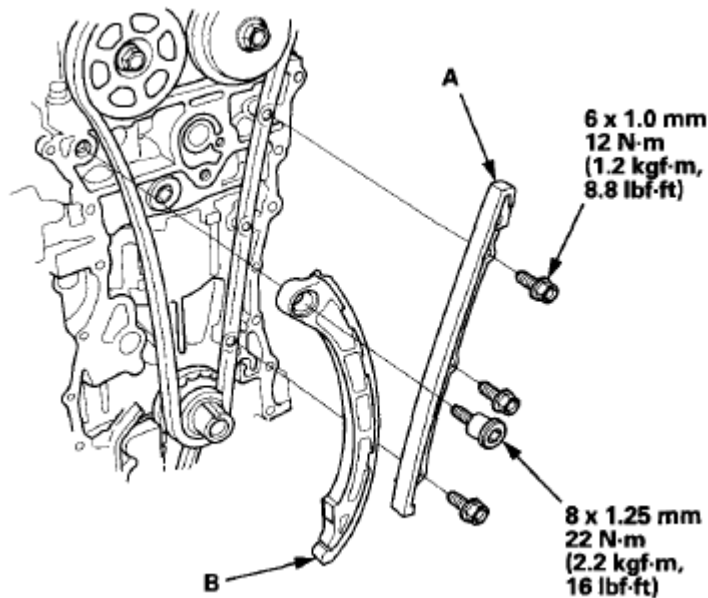

Fig. 40: Identifying Cam Chain Tensioner Mounting Bolt With Torque Specifications
Courtesy of AMERICAN HONDA MOTOR CO., INC.

8. Install cam chain guide A and the tensioner arm (B).
9. Compress the auto-tensioner when replacing the cam chain. Remove the pin (P/N 14511-PNA-003) (A) from the auto-tensioner that was installed during removal. Turn the plate (B) counterclockwise, to release the lock, then press the rod (C), and set the first cam (D) to the edge of the rack (E). Insert the 1.2 mm (0.05 in) diameter pin or lock pin into the holes (F).

NOTE: If the chain tensioner is not set up as described, the tensioner will become damaged.

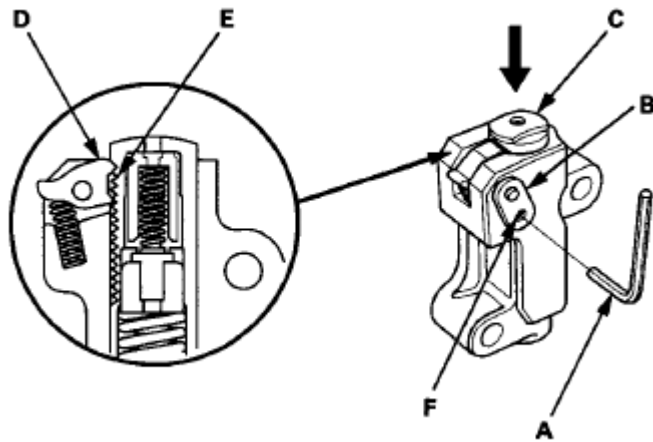

Fig. 41: Identifying Tensioner Arm, Cam And Rod
Courtesy of AMERICAN HONDA MOTOR CO., INC.

10. Install the auto-tensioner.

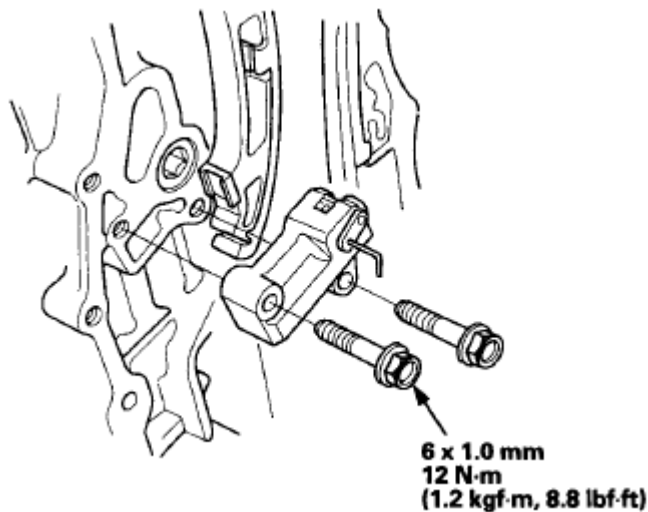

Fig. 42: Identifying Auto-Tensioner With Torque Specifications
Courtesy of AMERICAN HONDA MOTOR CO., INC.

11. Install cam chain guide B.

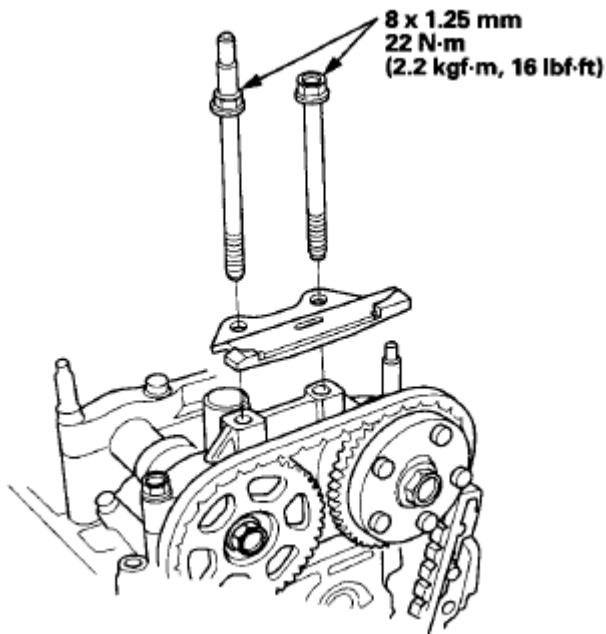

Fig. 43: Identifying Cam Chain Guide With Torque Specifications
Courtesy of AMERICAN HONDA MOTOR CO., INC.

12. Remove the pin or lock pin (P/N 14511-PNA-003) from the auto-tensioner.

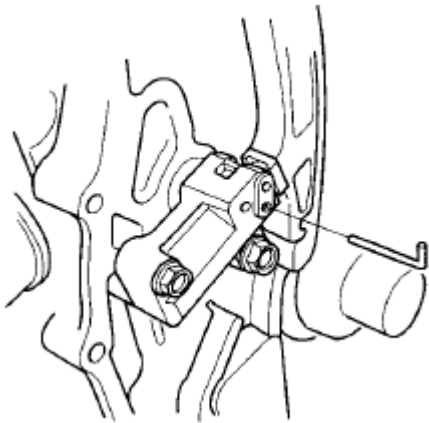

Fig. 44: Identifying Lock Pin And Auto-Tensioner
Courtesy of AMERICAN HONDA MOTOR CO., INC.

13. Remove the camshaft lock pin set.

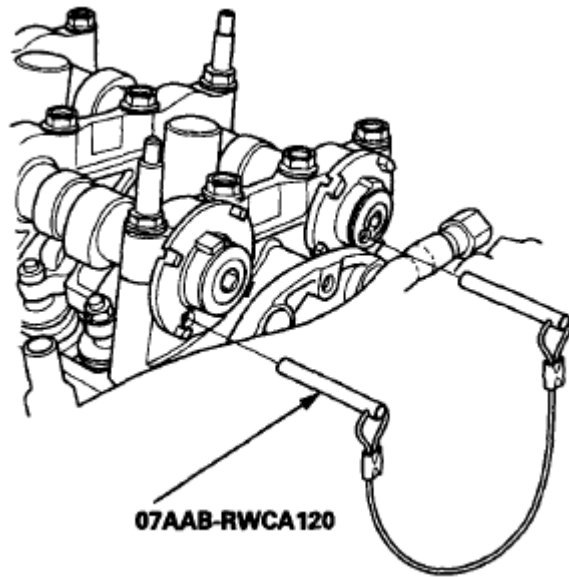

Fig. 45: Removing Camshaft Lock Pin Set
Courtesy of AMERICAN HONDA MOTOR CO., INC.

14. Check the chain case oil seal for damage. If the oil seal is damaged, replace the chain case oil seal (see **CAM CHAIN CASE OIL SEAL INSTALLATION**).
15. Remove old liquid gasket from the chain case mating surfaces, bolts, and bolt holes.
16. Clean and dry the chain case mating surfaces.
17. Apply liquid gasket (P/N 08717-0004, 08718-0003, or 08718-0009) to the engine block mating surface of the chain case and to the inside edge of the bolt holes. Install the component within 5 minutes of applying the liquid gasket.

NOTE:

- Apply a 3 mm (0.12 in) diameter bead of liquid gasket along the broken line (A).
- If too much time has passed after applying the liquid gasket, remove the old liquid gasket and residue, then reapply new liquid gasket.

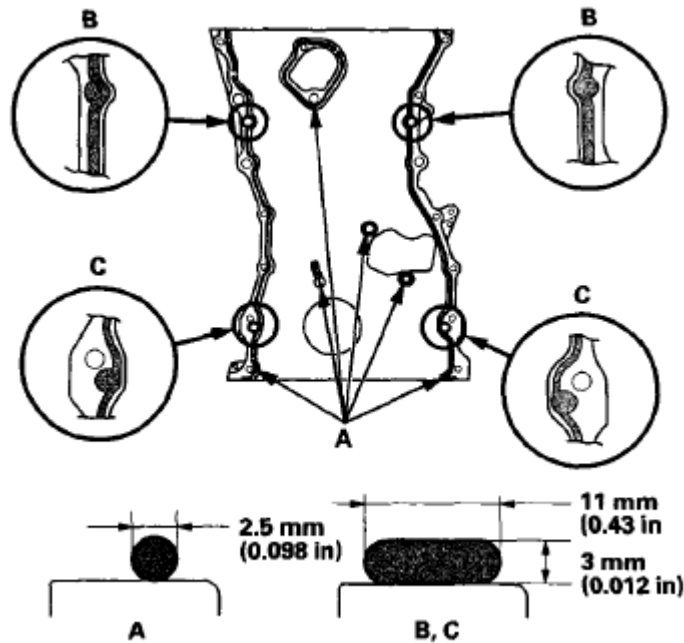

Fig. 46: Identifying Engine Block Mating Surface Sealant Area
Courtesy of AMERICAN HONDA MOTOR CO., INC.

18. Apply liquid gasket to the engine block upper surface contact areas (B) and the lower block upper surface contact areas (C) on the chain case.

NOTE: Apply about 11 mm (0.43 in) diameter and about 3 mm (0.12 in) thickness of liquid gasket to the areas (B) and (C).

19. Apply liquid gasket (P/N 08717-0004, 08718-0003, or 08718-0009) to the oil pan mating surface of the oil pump. Install the component within 5 minutes of applying the liquid gasket.

NOTE:

- Apply a 3 mm (0.12 in) diameter bead of liquid gasket along the broken line (A).
- If too much time has passed after applying the liquid gasket, remove the old liquid gasket and residue, then reapply new liquid gasket.

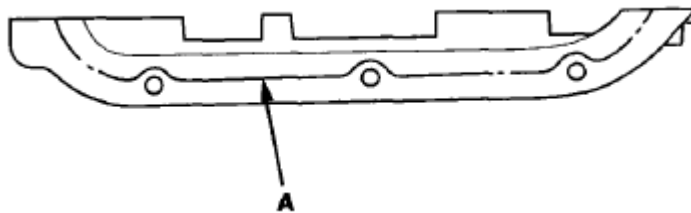

Fig. 47: Identifying Cylinder Head Sealant Broken Line
Courtesy of AMERICAN HONDA MOTOR CO., INC.

20. Install the new O-ring (A), the side engine mount bracket (B), and the mounting bolts (C) on the chain case. Set the edge of the chain case (D) to the edge of the oil pan (E), then install the chain case on the engine block (F). Wipe off the excess liquid gasket on the oil pan and chain case mating area.

NOTE:

- When installing the chain case, do not slide the bottom surface onto the oil pan mounting surface.
- Wait at least 30 minutes to allow the liquid gasket to cure before filling the engine with oil.
- Do not run the engine for at least 3 hours after installing the chain case.

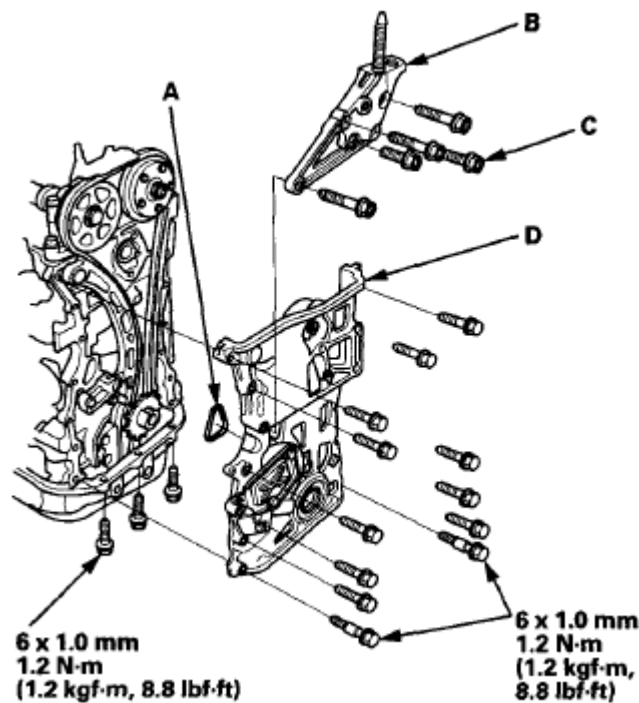

Fig. 48: Identifying O-Ring, Side Engine Mount Bracket, Mounting Bolts And Chain Case With Torque Specifications
Courtesy of AMERICAN HONDA MOTOR CO., INC.

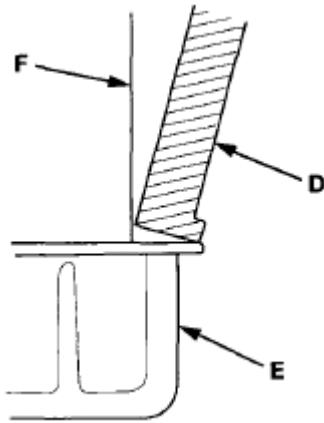

Fig. 49: Identifying Chain Case, Engine Block And Oil Pan
 Courtesy of AMERICAN HONDA MOTOR CO., INC.

21. Tighten the side engine mount bracket mounting bolts.

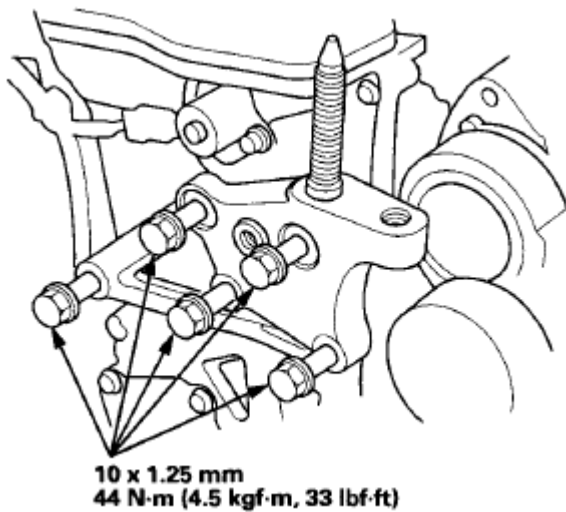

Fig. 50: Identifying Side Engine Mount Bracket Mounting Bolts With Torque Specifications
 Courtesy of AMERICAN HONDA MOTOR CO., INC.

22. Install the side engine mount bracket (A), then loosely tighten the new bolt and nut (B), and loosely tighten the bolt (C).

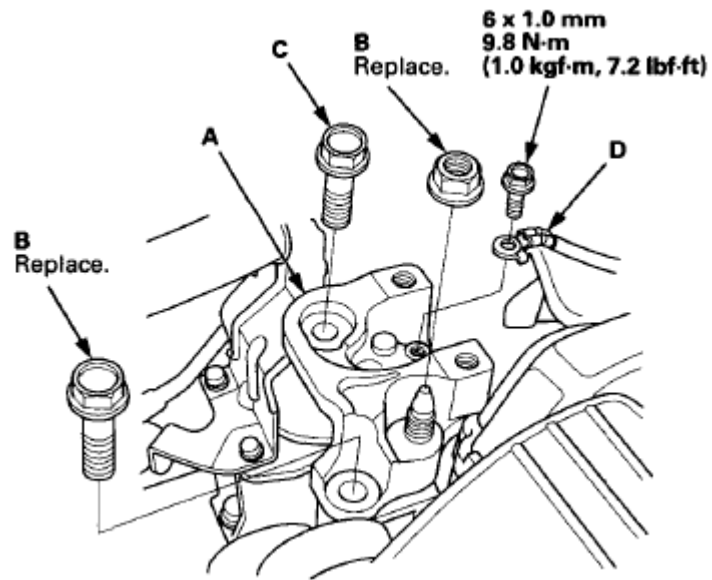

Fig. 51: Identifying Side Engine Mount Bracket, Bolt And Nut With Torque Specifications
Courtesy of AMERICAN HONDA MOTOR CO., INC.

23. Install the ground cable (D).
24. Remove the air cleaner housing assembly (see [AIR CLEANER REMOVAL/INSTALLATION](#)).
25. Loosen the transmission mounting bolt and nuts (A).

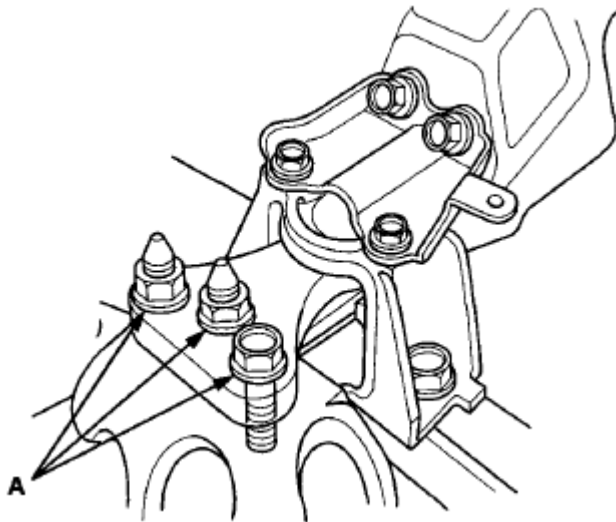

Fig. 52: Identifying Transmission Mounting Bolt And Nuts
Courtesy of AMERICAN HONDA MOTOR CO., INC.

26. Raise the vehicle on the lift.
27. Loosen the lower torque rod mounting bolt (A).

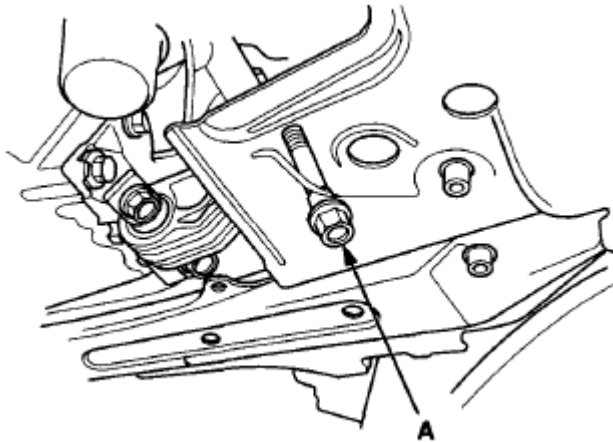

Fig. 53: Identifying Lower Torque Rod Mounting Bolt
 Courtesy of AMERICAN HONDA MOTOR CO., INC.

28. Lower the vehicle on the lift.
29. Tighten the side engine mount mounting bolts and nut.

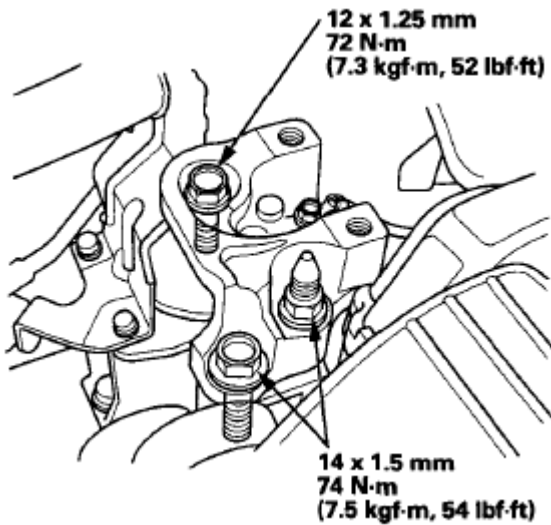

Fig. 54: Identifying Side Engine Mount Mounting Bolts And Nut With Torque Specifications
 Courtesy of AMERICAN HONDA MOTOR CO., INC.

30. Tighten the transmission mounting bolt and nuts.

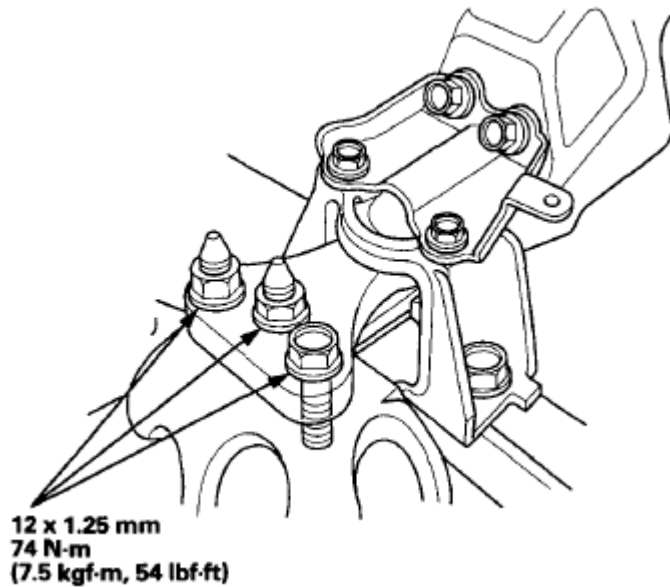

Fig. 55: Identifying Transmission Mounting Bolt And Nuts With Torque Specifications
Courtesy of AMERICAN HONDA MOTOR CO., INC.

31. Raise the vehicle on the lift.
32. Tighten the lower torque rod mounting bolt.

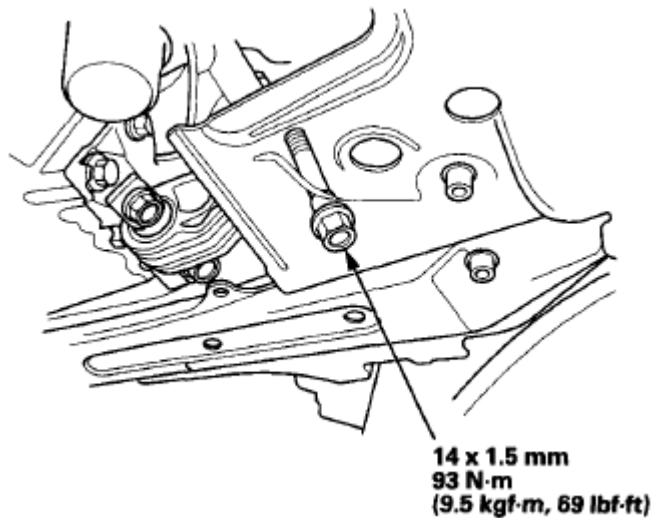

Fig. 56: Identifying Lower Torque Rod Mounting Bolt With Torque Specification
Courtesy of AMERICAN HONDA MOTOR CO., INC.

33. Lower the vehicle on the lift.
34. Install the air cleaner housing assembly (see **AIR CLEANER REMOVAL/INSTALLATION**).
35. Install the upper torque rod, then tighten the new upper torque rod mounting bolts in the numbered sequence shown.

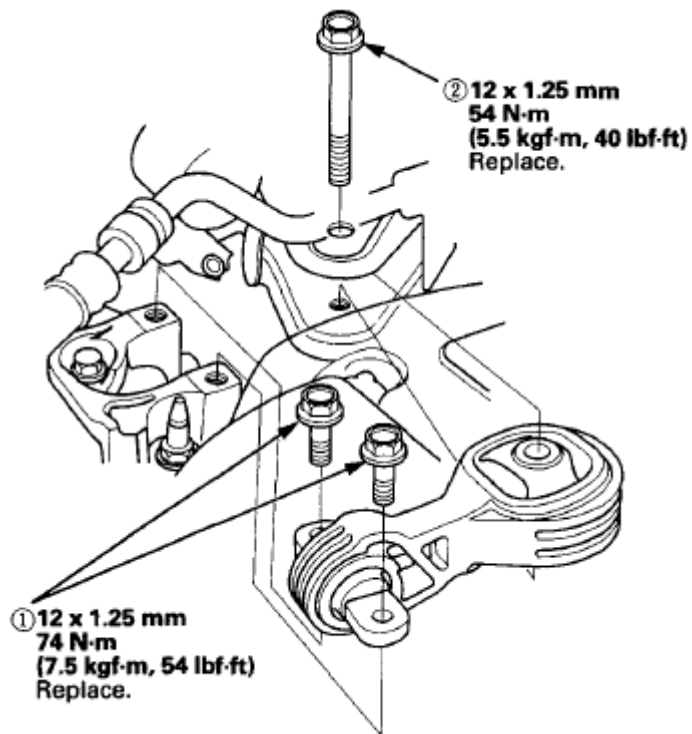

Fig. 57: Identifying Upper Torque Rod And Upper Torque Rod Mounting Bolts With Torque Specifications

Courtesy of AMERICAN HONDA MOTOR CO., INC.

36. Install the crankshaft pulley (see **CRANKSHAFT PULLEY REMOVAL AND INSTALLATION**).
37. Install the VTC oil control solenoid valve (see **VTC OIL CONTROL SOLENOID VALVE REMOVAL/TEST/INSTALLATION**).
38. Connect the crankshaft position (CKP) sensor connector (A) and VTC oil control solenoid valve connector (B).

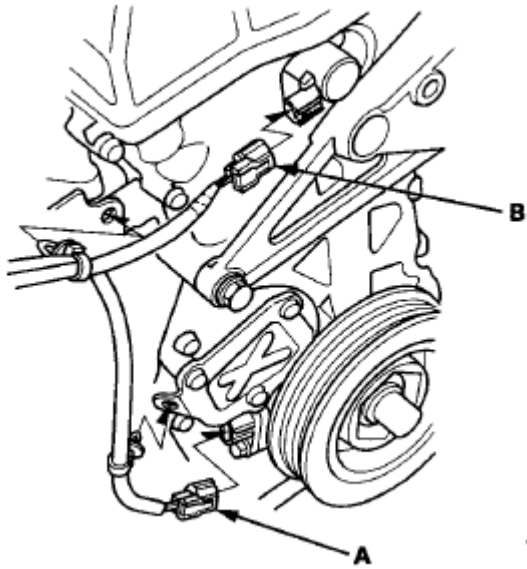

Fig. 58: Identifying Crankshaft Position Sensor Connector And VTC Oil Control Solenoid Valve Connector

Courtesy of AMERICAN HONDA MOTOR CO., INC.

39. Install the cylinder head cover (see **CYLINDER HEAD COVER INSTALLATION**).
40. Install the drive belt (see **DRIVE BELT REMOVAL/INSTALLATION**).
41. Install the splash shield (see **FRONT SPLASH SHIELD REPLACEMENT**).
42. Install the front wheels.
43. Do the CKP pattern clear/CKP learn procedure (see **HDS CLEAR COMMAND**).

CAM CHAIN AUTO-TENSIONER REMOVAL AND INSTALLATION

Removal

1. Remove the chain case cover.

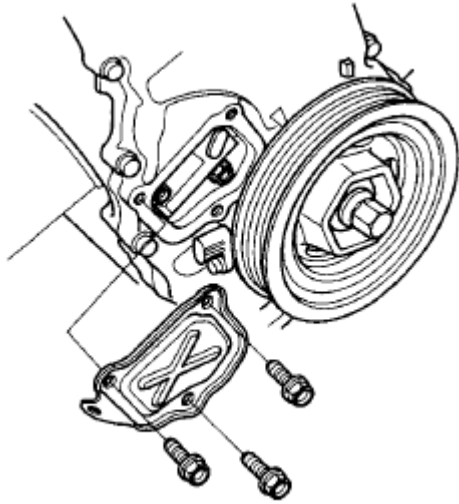

Fig. 59: Identifying Chain Case Cover
Courtesy of AMERICAN HONDA MOTOR CO., INC.

2. Turn the crankshaft counterclockwise to compress the auto-tensioner.

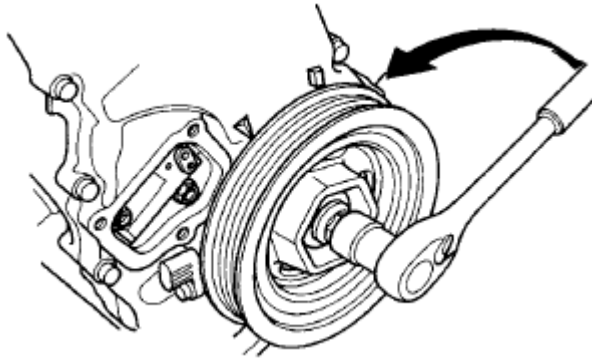

Fig. 60: Turning Crankshaft Counterclockwise
Courtesy of AMERICAN HONDA MOTOR CO., INC.

3. Align the holes on the lock (A) and the auto-tensioner (B), then insert a 1.2 mm (0.05 in) diameter pin or lock pin (P/N 14511-PNA-003) (C) into the holes. Turn the crankshaft clockwise to secure the pin.

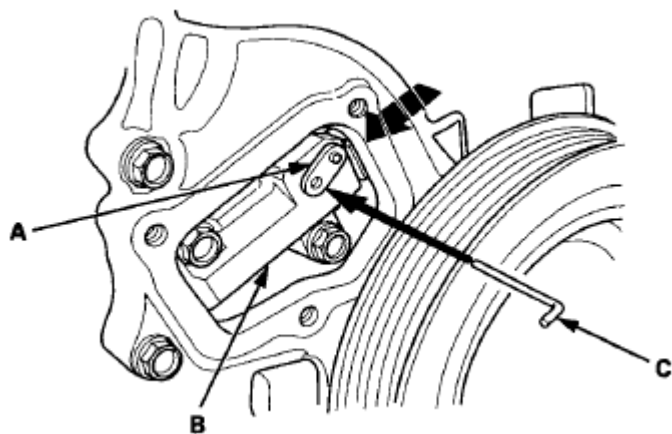

Fig. 61: Aligning Holes On Lock And Auto-Tensioner
Courtesy of AMERICAN HONDA MOTOR CO., INC.

4. Remove the auto-tensioner.

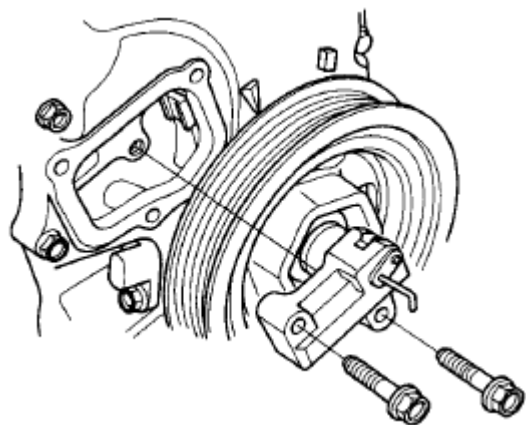

Fig. 62: Identifying Auto-Tensioner
Courtesy of AMERICAN HONDA MOTOR CO., INC.

Installation

1. Install the auto-tensioner.

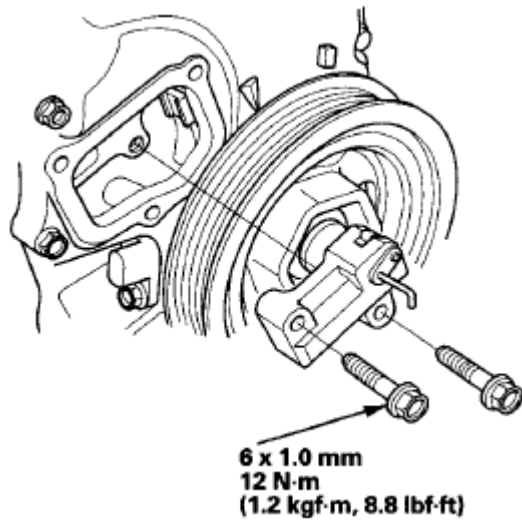

Fig. 63: Identifying Auto-Tensioner
Courtesy of AMERICAN HONDA MOTOR CO., INC.

- Remove the pin or lock pin (P/N 14511-PNA-003) from the auto-tensioner.

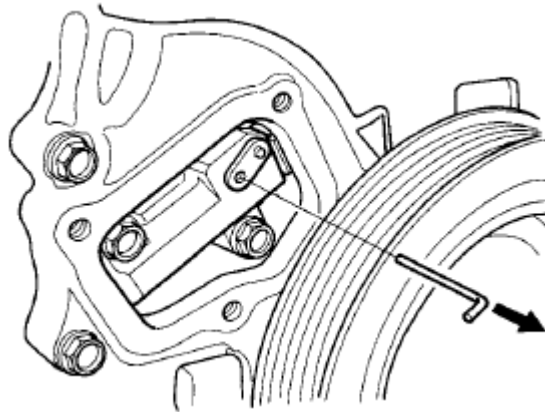

Fig. 64: Identifying Lock Pin (P/N 14511-PNA-003) And Auto-Tensioner
Courtesy of AMERICAN HONDA MOTOR CO., INC.

- Remove old liquid gasket from the chain case cover mating surfaces, bolts, and bolt holes.
- Clean and dry the chain case cover mating surfaces.
- Apply liquid gasket (P/N 08717-0004, 08718-0003, or 08718-0009) to the chain case mating surface of the chain case cover and to the inside edge of the bolt holes. Install the component within 5 minutes of applying the liquid gasket.

NOTE:

- Apply a 3 mm (0.12 in) diameter bead of liquid gasket along the broken line (A).
- If too much time has passed after applying the liquid gasket, remove the old liquid gasket and residue, then reapply new liquid gasket.

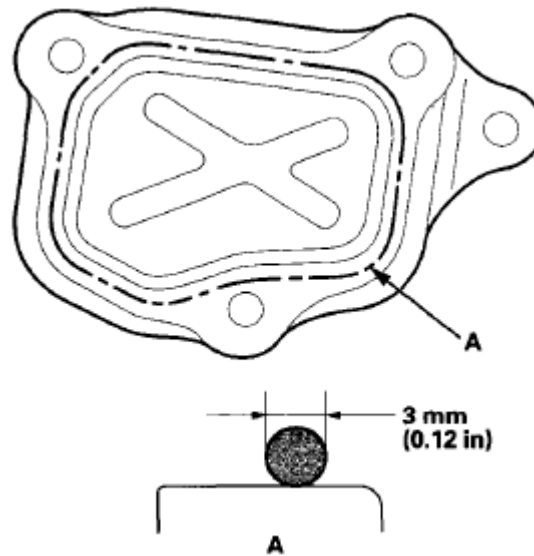

Fig. 65: Identifying Chain Case Mating Surface Sealant Area
 Courtesy of AMERICAN HONDA MOTOR CO., INC.

6. Install the chain case cover.

NOTE:

- Wait at least 30 minutes to allow the liquid gasket to cure before filling the engine with oil.
- Do not run the engine for at least 3 hours after installing the chain case cover.

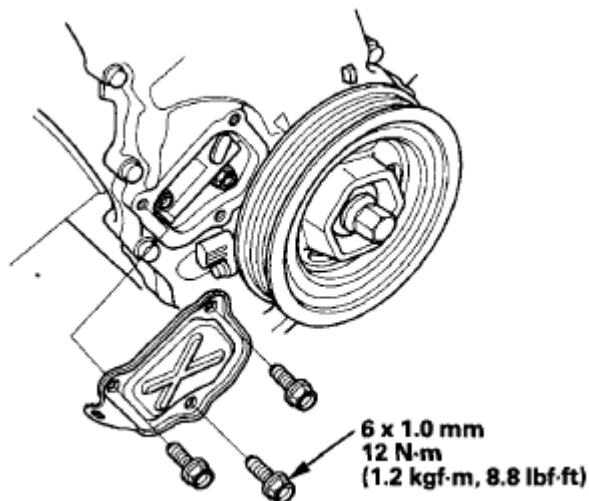

Fig. 66: Identifying Chain Case Cover And Mounting Bolts With Torque Specification
 Courtesy of AMERICAN HONDA MOTOR CO., INC.

CAM CHAIN CASE OIL SEAL INSTALLATION

Special Tools Required

- Driver Handle, 15 x 135L 07749-0010000
 - Attachment, 52 x 55 mm 07746-0010400
1. Use the driver and attachment to drive a new oil seal squarely into the chain case to the specified installed height.

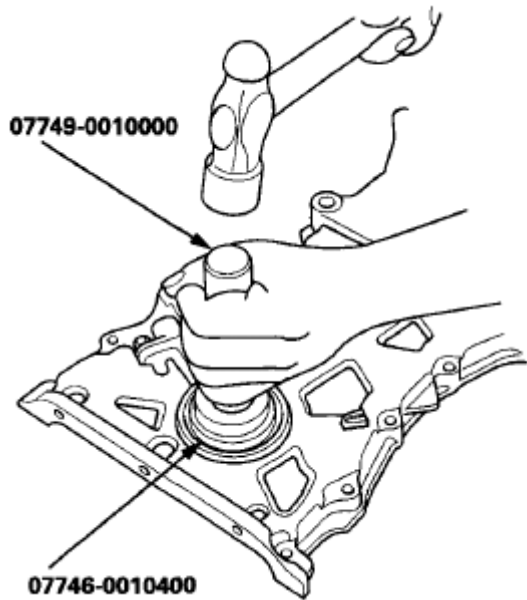

Fig. 67: Installing Cam Chain Case Oil Seal
Courtesy of AMERICAN HONDA MOTOR CO., INC.

2. Measure the distance between the chain case surface (A) and oil seal (B).

Oil Seal Installed Height:

33.0-33.7 mm (1.30-1.33 in)

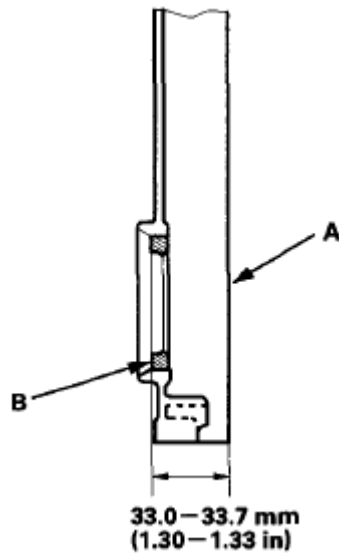

Fig. 68: Measuring Distance Between Chain Case Surface And Oil Seal
 Courtesy of AMERICAN HONDA MOTOR CO., INC.

CAM CHAIN INSPECTION

1. Raise the vehicle on the lift, and remove the front wheels.
2. Remove the splash shield (see **FRONT SPLASH SHIELD REPLACEMENT**).
3. Remove the drive belt (see **DRIVE BELT REMOVAL/INSTALLATION**).
4. Remove the cylinder head cover (see **CYLINDER HEAD COVER REMOVAL**).
5. Set the No. 1 piston at top dead center (TDC). The punch mark on the variable valve timing control (VTC) actuator and the punch mark on the exhaust camshaft sprocket should be at the top. Align the TDC marks on the VTC actuator and the exhaust camshaft sprocket (see step 5).
6. Disconnect the crankshaft position (CKP) sensor connector and the VTC oil control solenoid valve connector (see step 6).
7. Remove the VTC oil control solenoid valve (see **VTC OIL CONTROL SOLENOID VALVE REMOVAL/TEST/INSTALLATION**).
8. Remove the crankshaft pulley (see **CRANKSHAFT PULLEY REMOVAL AND INSTALLATION**).
9. Support the engine with a jack and a wood block under the oil pan.
10. Remove the upper torque rod (see step 10).
11. Remove the ground cable, then remove the side engine mount bracket (see step 11).
12. Remove the side engine mount bracket mounting bolts (see step 12).
13. Remove the cam chain case and side engine mount bracket (see step 13).
14. Measure the tensioner rod length between the tensioner body and bottom of the flat surface section on the tensioner rod. If the length is more than the service limit, replace the cam chain and the oil pump chain.

Tensioner Rod Length

Service Limit: 13.5 mm (0.53 in)

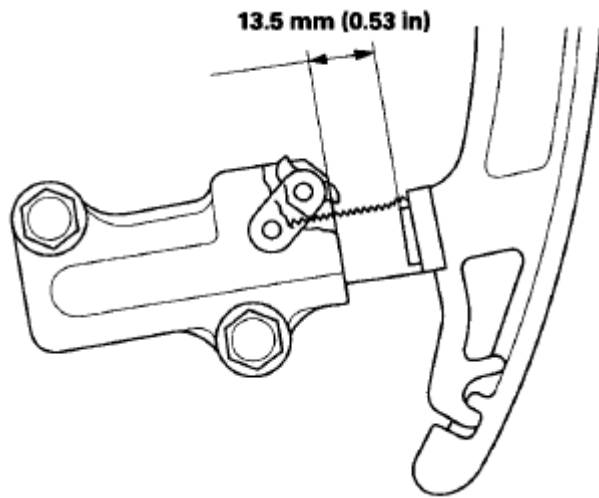

Fig. 69: Identifying Tensioner Rod Length

Courtesy of AMERICAN HONDA MOTOR CO., INC.

15. Check the chain case oil seal for damage. If the oil seal is damaged, replace the chain case oil seal (see **CAM CHAIN CASE OIL SEAL INSTALLATION**).
16. Remove all of the old liquid gasket from the chain case mating surfaces, bolts, and bolt holes.
17. Clean and dry the chain case mating surfaces.
18. Apply liquid gasket (P/N 08717-0004, 08718-0003, or 08718-0009) to the engine block mating surface of the chain case and to the inside edge of the bolt holes. Install the component within 5 minutes of applying the liquid gasket (see step [17](#)).

NOTE:

- Apply a 3 mm (0.12 in) diameter bead of liquid gasket along the broken line.
- If too much time has passed after applying the liquid gasket, remove the old liquid gasket and residue, then reapply new liquid gasket.

19. Apply liquid gasket to the engine block upper surface contact areas and the lower block upper surface contact areas on the chain case (see step [18](#)).

NOTE:

Apply about 11 mm (0.43 in) diameter and about 3 mm (0.12 in) thickness of liquid gasket to these areas.

20. Apply liquid gasket (P/N 08717-0004, 08718-0003, or 08718-0009) to the oil pan mating surface of the oil pump. Install the component within 5 minutes of applying the liquid gasket (see step [19](#)).

NOTE:

- Apply a 3 mm (0.12 in) diameter bead of liquid gasket along the broken line.
- If too much time has passed after applying the liquid gasket, remove the old liquid gasket and residue, then reapply new liquid gasket.

21. Install the new O-ring, side engine mount bracket, and mounting bolts on the chain case. Set the edge of the chain case to the edge of the oil pan, then install the chain case on the engine block (see step 20). Wipe off the excess liquid gasket on the oil pan and the chain case mating area.

NOTE:

- **When installing the chain case, do not slide the bottom surface onto the oil pan mounting surface.**
- **Wait at least 30 minutes to allow the liquid gasket to cure before filling the engine with oil.**
- **Do not run the engine for at least 3 hours after installing the chain case.**

22. Tighten the side engine mount bracket mounting bolts (see step 21).
23. Install the side engine mount bracket, then loosely tighten the new bolt and nut, and loosely tighten the bolt. Install the ground cable (see step 22).
24. Remove the air cleaner housing assembly (see **AIR CLEANER REMOVAL/INSTALLATION**).
25. Loosen the transmission mounting bolt and nuts (see step 25).
26. Raise the vehicle on the lift.
27. Loosen the lower torque rod mounting bolt (see step 27).
28. Lower the vehicle on the lift.
29. Tighten the side engine mount mounting bolts and nut (see step 29).
30. Tighten the transmission mounting bolt and nuts (see step 30).
31. Raise the vehicle on the lift.
32. Tighten the lower torque rod mounting bolt (see step 32).
33. Lower the vehicle on the lift.
34. Install the air cleaner housing assembly (see **AIR CLEANER REMOVAL/INSTALLATION**).
35. Install the upper torque rod, then tighten the new upper torque rod mounting bolts in the numbered sequence shown (see step 35).
36. Install the VTC oil control solenoid valve (see **VTC OIL CONTROL SOLENOID VALVE REMOVAL/TEST/INSTALLATION**).
37. Connect the CKP sensor connector and VTC oil control solenoid valve connector (see step 38).
38. Install the crankshaft pulley (see **CRANKSHAFT PULLEY REMOVAL AND INSTALLATION**).
39. Install the cylinder head cover (see **CYLINDER HEAD COVER INSTALLATION**).
40. Install the drive belt (see **DRIVE BELT REMOVAL/INSTALLATION**).
41. Install the splash shield (see **FRONT SPLASH SHIELD REPLACEMENT**).
42. Install the front wheels.
43. Do the CKP pattern clear/CKP learn procedure (see **CKP PATTERN CLEAR/CKP PATTERN LEARN**).

CKP PULSE PLATE REPLACEMENT

1. Raise the vehicle on the lift, and remove the front wheels.

2. Remove the front splash shield (see **FRONT SPLASH SHIELD REPLACEMENT**).
3. Remove the drive belt (see **DRIVE BELT REMOVAL/INSTALLATION**).
4. Remove the cylinder head cover (see **CYLINDER HEAD COVER REMOVAL**).
5. Set the No. 1 piston at top dead center (TDC). The punch mark on the variable valve timing control (VTC) actuator and the punch mark on the exhaust camshaft sprocket should be at the top. Align the TDC marks on the VTC actuator and exhaust camshaft sprocket (see step 5).
6. Disconnect the crankshaft position (CKP) sensor connector and VTC oil control solenoid valve connector (see step 6).
7. Remove the VTC oil control solenoid valve (see **VTC OIL CONTROL SOLENOID VALVE REMOVAL/TEST/INSTALLATION**).
8. Remove the crankshaft pulley (see **CRANKSHAFT PULLEY REMOVAL AND INSTALLATION**).
9. Support the engine with a jack and a wood block under the oil pan.
10. Remove the upper torque rod (see step 10).
11. Remove the ground cable, then remove the side engine mount bracket (see step 11).
12. Remove the side engine mount bracket mounting bolts (see step 12).
13. Remove the cam chain case and side engine mount bracket (see step 13).
14. Remove the CKP pulse plate.

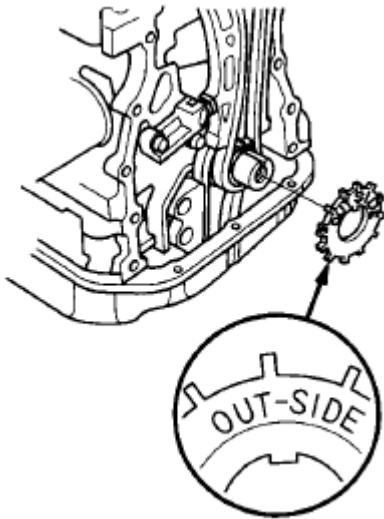

Fig. 70: Identifying CKP Pulse Plate

Courtesy of AMERICAN HONDA MOTOR CO., INC.

15. Install the CKP pulse plate.
16. Check the chain case oil seal for damage. If the oil seal is damaged, replace the chain case oil seal (see **CAM CHAIN CASE OIL SEAL INSTALLATION**).
17. Remove all of the old liquid gasket from the chain case mating surfaces, bolts, and bolt holes.
18. Clean and dry the chain case mating surfaces.
19. Apply liquid gasket (P/N 08717-0004, 08718-0003, or 08718-0009) to the engine block mating surface of the chain case and to the inside edge of the bolt holes. Install the component within 5 minutes of applying

the liquid gasket (see step 17).

NOTE:

- **Apply a 3 mm (0.12 in) diameter bead of liquid gasket along the broken line.**
- **If too much time has passed after applying the liquid gasket, remove the old liquid gasket and residue, then reapply new liquid gasket.**

20. Apply liquid gasket to the engine block upper surface contact areas and the lower block upper surface contact areas on the chain case (see step 18).

NOTE:

Apply about 11 mm (0.43 in) diameter and about 3 mm (0.12 in) thickness of liquid gasket to these areas.

21. Apply liquid gasket (P/N 08717-0004, 08718-0003, or 08718-0009) to the oil pan mating surface of the oil pump. Install the component within 5 minutes of applying the liquid gasket (see step 19).

NOTE:

- **Apply a 3 mm (0.12 in) diameter bead of liquid gasket along the broken line.**
- **If too much time has passed after applying the liquid gasket, remove the old liquid gasket and residue, then reapply new liquid gasket.**

22. Install the new O-ring, side engine mount bracket, and mounting bolts on the chain case. Set the edge of the chain case to the edge of the oil pan, then install the chain case on the engine block (see step 20). Wipe off the excess liquid gasket on the oil pan and the chain case mating area.

NOTE:

- **When installing the chain case, do not slide the bottom surface onto the oil pan mounting surface.**
- **Wait at least 30 minutes to allow the liquid gasket to cure before filling the engine with oil.**
- **Do not run the engine for at least 3 hours after installing the chain case.**

23. Tighten the side engine mount bracket mounting bolts (see step 21).
24. Install the side engine mount bracket, then loosely tighten the new bolt and nut, and loosely tighten the bolt. Install the ground cable (see step 22).
25. Remove the air cleaner housing assembly (see [AIR CLEANER REMOVAL/INSTALLATION](#)).
26. Loosen the transmission mounting bolt and nuts (see step 25).
27. Raise the vehicle on the lift.
28. Loosen the lower torque rod mounting bolt (see step 27).
29. Lower the vehicle on the lift.
30. Tighten the side engine mount mounting bolts and nut (see step 29).
31. Tighten the transmission mounting bolt and nuts (see step 30).

32. Raise the vehicle on the lift.
33. Tighten the lower torque rod mounting bolt (see step 32).
34. Lower the vehicle on the lift.
35. Install the air cleaner housing assembly (see **AIR CLEANER REMOVAL/INSTALLATION**).
36. Install the upper torque rod, then tighten the new upper torque rod mounting bolts in the numbered sequence shown (see step 35).
37. Install the VTC oil control solenoid valve (see **VTC OIL CONTROL SOLENOID VALVE REMOVAL/TEST/INSTALLATION**).
38. Connect the CKP sensor connector and VTC oil control solenoid valve connector (see step 38).
39. Install the crankshaft pulley (see **CRANKSHAFT PULLEY REMOVAL AND INSTALLATION**).
40. Install the cylinder head cover (see **CYLINDER HEAD COVER INSTALLATION**).
41. Install the drive belt (see **DRIVE BELT REMOVAL/INSTALLATION**).
42. Install the splash shield (see **FRONT SPLASH SHIELD REPLACEMENT**).
43. Install the front wheels.
44. Do the CKP pattern clear/CKP learn procedure (see **CKP PATTERN CLEAR/CKP PATTERN LEARN**).

CYLINDER HEAD COVER REMOVAL

1. Remove the intake manifold cover.

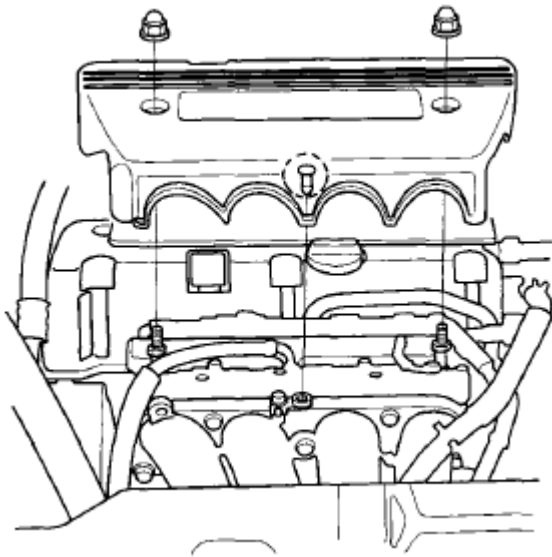

Fig. 71: Identifying Intake Manifold Cover
Courtesy of AMERICAN HONDA MOTOR CO., INC.

2. Remove the four ignition coils (see **IGNITION COIL AND SPARK PLUG REMOVAL/INSTALLATION**).
3. Disconnect the evaporative emission (EVAP) canister purge valve connector.

4. Remove the dipstick (A), the breather hose (B), and the power steering (P/S) hose clamp (C).

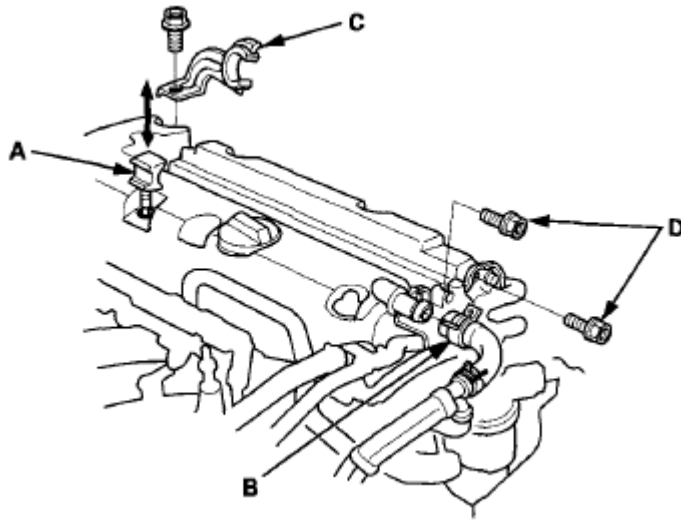

Fig. 72: Identifying Dipstick, Breather Hose And Power Steering (P/S) Hose Clamp
 Courtesy of AMERICAN HONDA MOTOR CO., INC.

5. Remove the two bolts (D) securing the EVAP canister purge valve bracket.
 6. Remove the cylinder head cover.

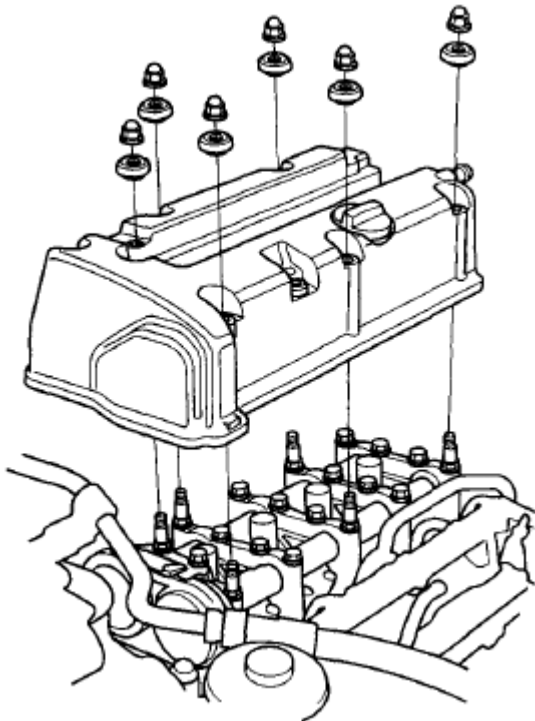

Fig. 73: Identifying Cylinder Head Cover
 Courtesy of AMERICAN HONDA MOTOR CO., INC.

CYLINDER HEAD COVER INSTALLATION

1. Thoroughly clean the head cover gasket and the groove.
2. Install the head cover gasket (A) in the groove of the cylinder head cover (B).

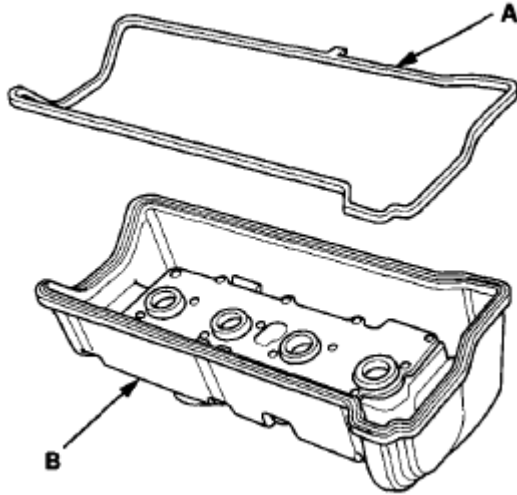

Fig. 74: Identifying Head Cover Gasket And Cylinder Head Cover
 Courtesy of AMERICAN HONDA MOTOR CO., INC.

3. Check that the mating surfaces are clean and dry.
4. Apply liquid gasket, P/N 08717-0004, 08718-0003, or 08718-0009, on the chain case and the No. 5 rocker shaft holder mating areas (A). Install the component within 5 minutes of applying the liquid gasket.

NOTE: If too much time has passed after applying the liquid gasket, remove the old liquid gasket and residue, then reapply new liquid gasket.

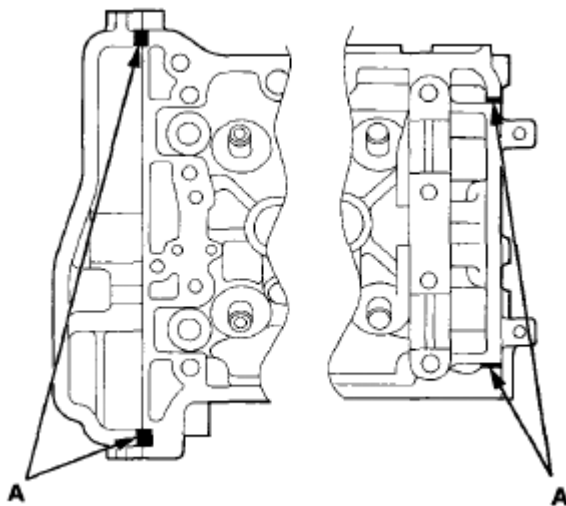

Fig. 75: Identifying Chain Case And No. 5 Rocker Shaft Holder Mating

Courtesy of AMERICAN HONDA MOTOR CO., INC.

5. Set the spark plug seals (A) on the spark plug tubes. Place the cylinder head cover (B) on the cylinder head, then slide the cover slightly back and forth to seat the head cover gasket.

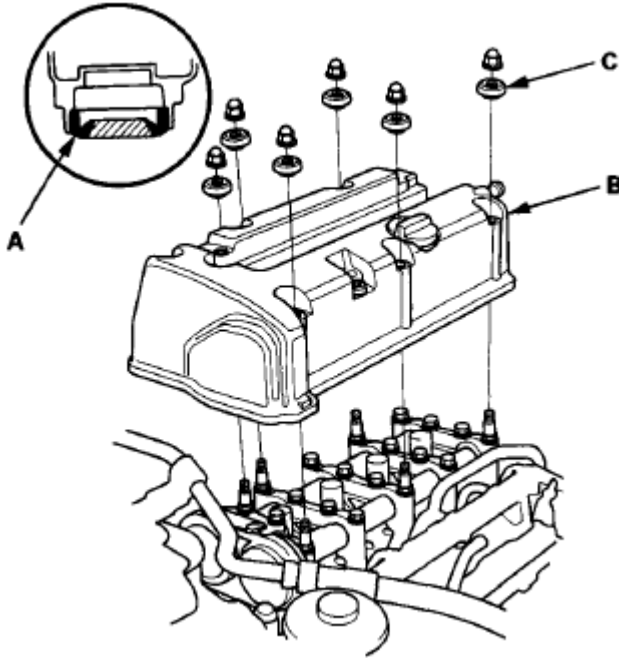

Fig. 76: Identifying Spark Plug Seals And Cylinder Head Cover
Courtesy of AMERICAN HONDA MOTOR CO., INC.

6. Inspect the cover washers (C). Replace any washer that is damaged or deteriorated.
7. Tighten the bolts in three steps. In the final step tighten all bolts, in sequence, to 12 N.m (1.2 kgf.m, 8.8 lbf.ft).

NOTE:

- Wait at least 30 minutes to allow the liquid gasket to cure before filling the engine with oil.
- Do not run the engine for at least 3 hours after installing the head cover.

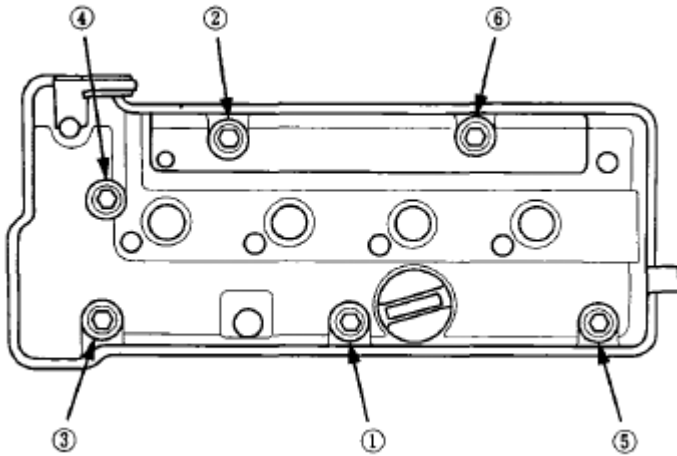

Fig. 77: Identifying Cylinder Head Cover Bolts Tighten Sequence
 Courtesy of AMERICAN HONDA MOTOR CO., INC.

8. Install two bolts (A) securing the evaporative emission (EVAP) canister purge valve bracket.

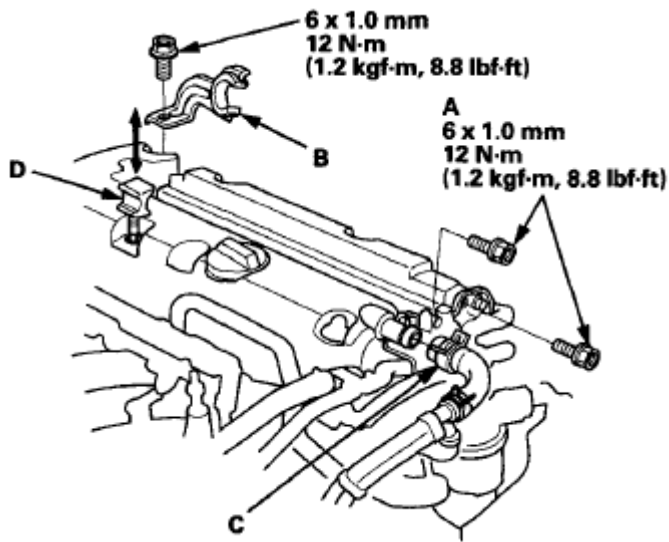

Fig. 78: Identifying Evaporative Emission Canister Purge Valve Bracket With Torque Specifications
 Courtesy of AMERICAN HONDA MOTOR CO., INC.

9. Install the power steering (P/S) hose clamp (B), breather hose (C), and the dipstick (D).
10. Connect the EVAP canister purge valve connector.
11. Install the four ignition coils (see **IGNITION COIL AND SPARK PLUG REMOVAL/INSTALLATION**).
12. Install the intake manifold cover.

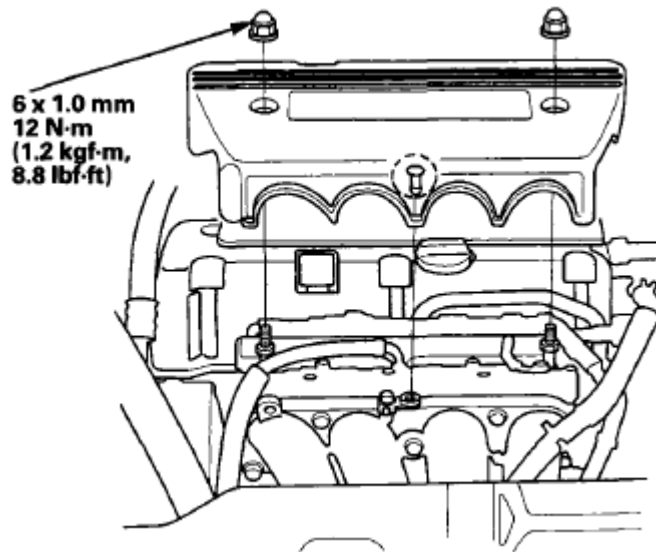

Fig. 79: Identifying Intake Manifold Cover And EVAP Canister Purge Valve Connector With Torque Specification

Courtesy of AMERICAN HONDA MOTOR CO., INC.

CYLINDER HEAD REMOVAL

NOTE:

- Use fender covers to avoid damaging painted surfaces.
- To avoid damage, unplug the wiring connectors carefully while holding the connector portion.
- To avoid damaging the cylinder head, wait until the engine coolant temperature drops below 100 °F (38 °C) before loosening the cylinder head bolts.
- Mark all wiring and hoses to avoid misconnection. Also, be sure that they do not contact other wiring or hoses, or interfere with other parts.

1. Relieve fuel pressure (see **FUEL PRESSURE RELIEVING**).
2. Drain the engine coolant (see **COOLANT CHECK**).
3. Remove the air cleaner housing (see **AIR CLEANER REMOVAL/INSTALLATION**).
4. Remove the drive belt (see **DRIVE BELT REMOVAL/INSTALLATION**).
5. Remove the intake manifold (see **REMOVAL**).
6. Remove the exhaust manifold (see **EXHAUST MANIFOLD REMOVAL AND INSTALLATION**).
7. Disconnect the evaporative emission (EVAP) canister hose (A) and the brake booster vacuum hose (B).

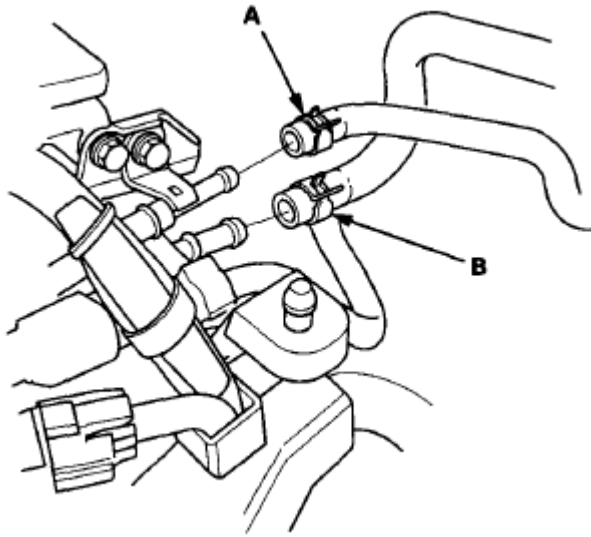

Fig. 80: Identifying Evaporative Emission Canister Hose And Brake Booster Vacuum Hose
 Courtesy of AMERICAN HONDA MOTOR CO., INC.

8. Remove the quick-connect fitting cover (A), then disconnect the fuel feed hose (B) (see **FUEL LINE/QUICK-CONNECT FITTING REMOVAL**).

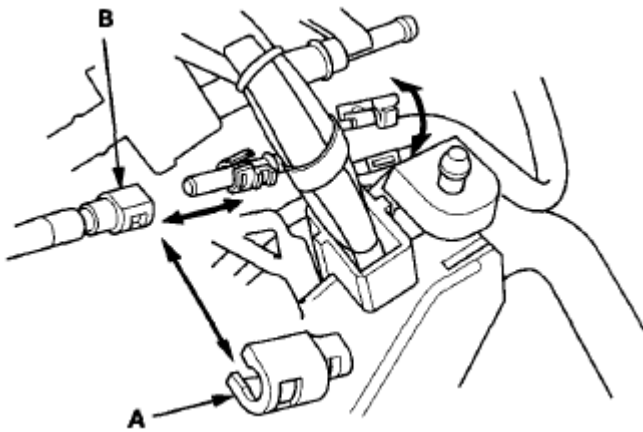

Fig. 81: Identifying Quick-Connect Fitting Cover And Fuel Feed Hose
 Courtesy of AMERICAN HONDA MOTOR CO., INC.

9. Disconnect the positive crankcase ventilation (PCV) hose (A) and remove the ground cable (B).

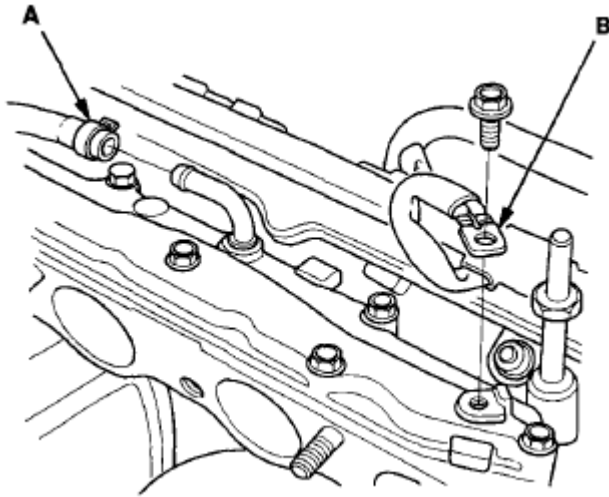

Fig. 82: Identifying Positive Crankcase Ventilation Hose And Ground Cable
Courtesy of AMERICAN HONDA MOTOR CO., INC.

10. Remove the harness holder (A) from the bracket, then remove the harness holder bracket (B).

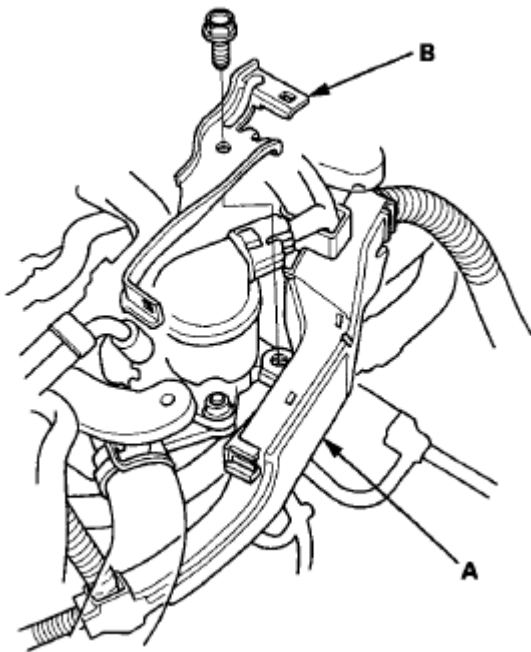

Fig. 83: Identifying Harness Holder, Bracket And Harness Holder Bracket
Courtesy of AMERICAN HONDA MOTOR CO., INC.

11. Disconnect the upper radiator hose (A) and the heater hoses (B).

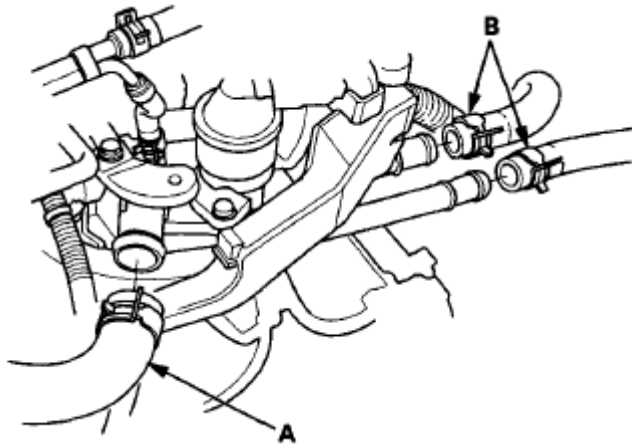

Fig. 84: Identifying Upper Radiator Hose And Heater Hoses
 Courtesy of AMERICAN HONDA MOTOR CO., INC.

12. Remove the bolt (A) securing the connecting pipe.

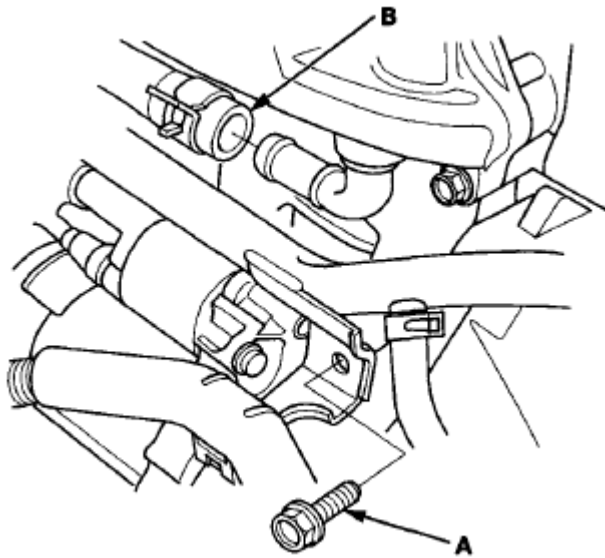

Fig. 85: Identifying Connecting Pipe And Bolt
 Courtesy of AMERICAN HONDA MOTOR CO., INC.

13. Disconnect the water bypass hose (B).
14. Remove the following engine wire harness connectors and wire harness clamps from the cylinder head:
- Four fuel injector connectors
 - Engine coolant temperature (ECT) sensor 1 connector
 - Camshaft position (CMP) sensor A (Intake) connector
 - Camshaft position (CMP) sensor B (Exhaust) connector
 - Rocker arm oil control solenoid connector
 - Rocker arm oil pressure switch connector

- EVAP canister purge valve connector
 - Exhaust gas recirculation (EGR) valve connector
15. Remove the cam chain (see **CAM CHAIN REMOVAL**).
 16. Remove the rocker arm assembly (see **ROCKER ARM ASSEMBLY REMOVAL**).
 17. Remove the cylinder head bolts. To prevent warpage, loosen the bolts in sequence 1/3 turn at a time; repeat the sequence until all bolts are loosened.

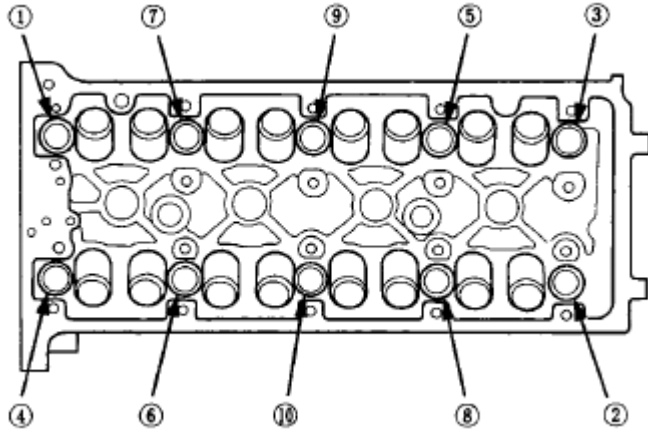

Fig. 86: Identifying Cylinder Head Bolts Remove Sequence
 Courtesy of AMERICAN HONDA MOTOR CO., INC.

18. Remove the cylinder head.

CMP PULSE PLATE A REPLACEMENT

1. Remove the cylinder head cover (see **CYLINDER HEAD COVER REMOVAL**).
2. Remove camshaft position (CMP) sensor A (see **CMP SENSOR A REPLACEMENT**).
3. Hold the camshaft with an open-end wrench, then loosen the bolt.

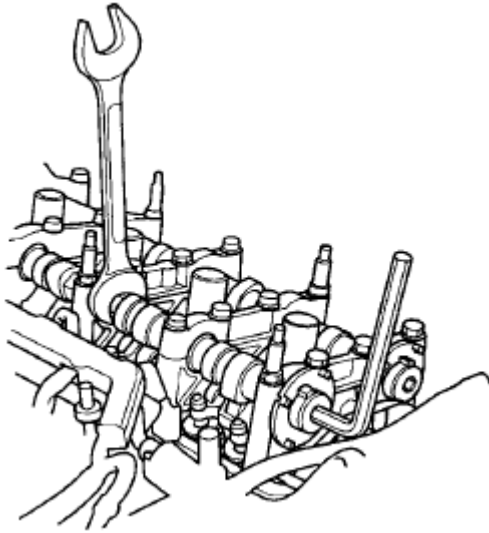

Fig. 87: Identifying Camshaft Position Sensor
Courtesy of AMERICAN HONDA MOTOR CO., INC.

4. Remove CMP pulse plate A

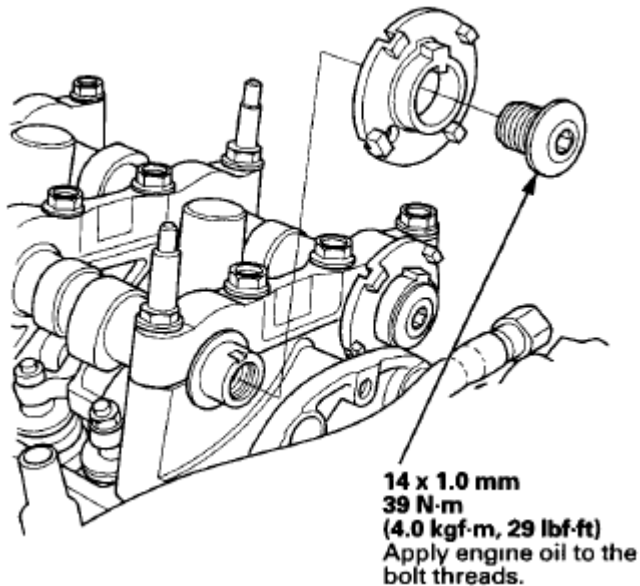

Fig. 88: Identifying CMP Pulse Plate With Torque Specifications
Courtesy of AMERICAN HONDA MOTOR CO., INC.

5. Install CMP pulse plate A in the reverse order of removal.

CMP PULSE PLATE B REPLACEMENT

1. Remove the cylinder head cover (see **CYLINDER HEAD COVER REMOVAL**).
2. Remove camshaft position (CMP) sensor B (see **CMP SENSOR B REPLACEMENT**).

3. Hold the camshaft with an open-end wrench, then loosen the bolt.

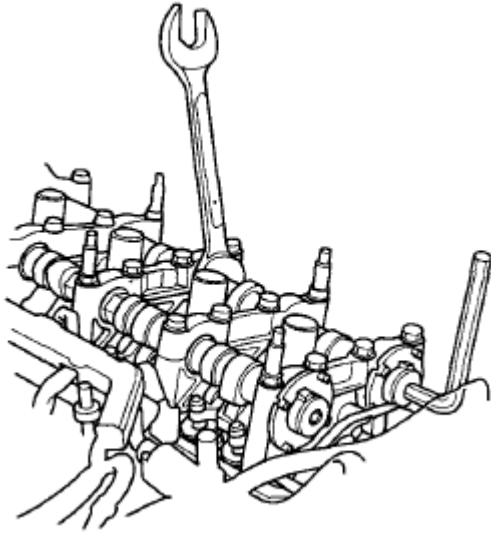

Fig. 89: Identifying Camshaft Position Sensor B
 Courtesy of AMERICAN HONDA MOTOR CO., INC.

4. Remove CMP pulse plate B.

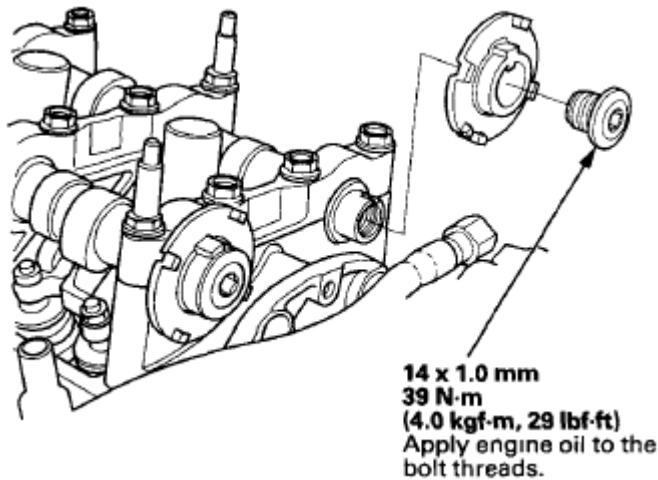

Fig. 90: Identifying CMP Pulse Plate With Torque Specification
 Courtesy of AMERICAN HONDA MOTOR CO., INC.

5. Install CMP pulse plate B in the reverse order of removal.

VTC ACTUATOR, EXHAUST CAMSHAFT SPROCKET REPLACEMENT

1. Remove the cylinder head cover **Cylinder Head Cover Removal**.
2. Hold the camshaft with an open-end wrench, then loosen the VTC actuator mounting bolt and the exhaust camshaft sprocket mounting bolt.

NOTE: Do not remove the VTC actuator and the exhaust camshaft sprocket mounting bolts.

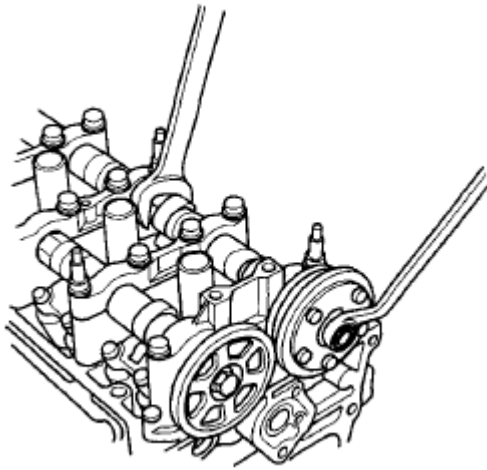

Fig. 91: Holding Camshaft

Courtesy of AMERICAN HONDA MOTOR CO., INC.

3. Set the No. 1 piston at top dead center (TDC). The punch mark (A) on the VTC actuator and the punch mark (B) on the exhaust camshaft sprocket should be at the top. Align the TDC marks (C) on the VTC actuator and the exhaust camshaft sprocket.

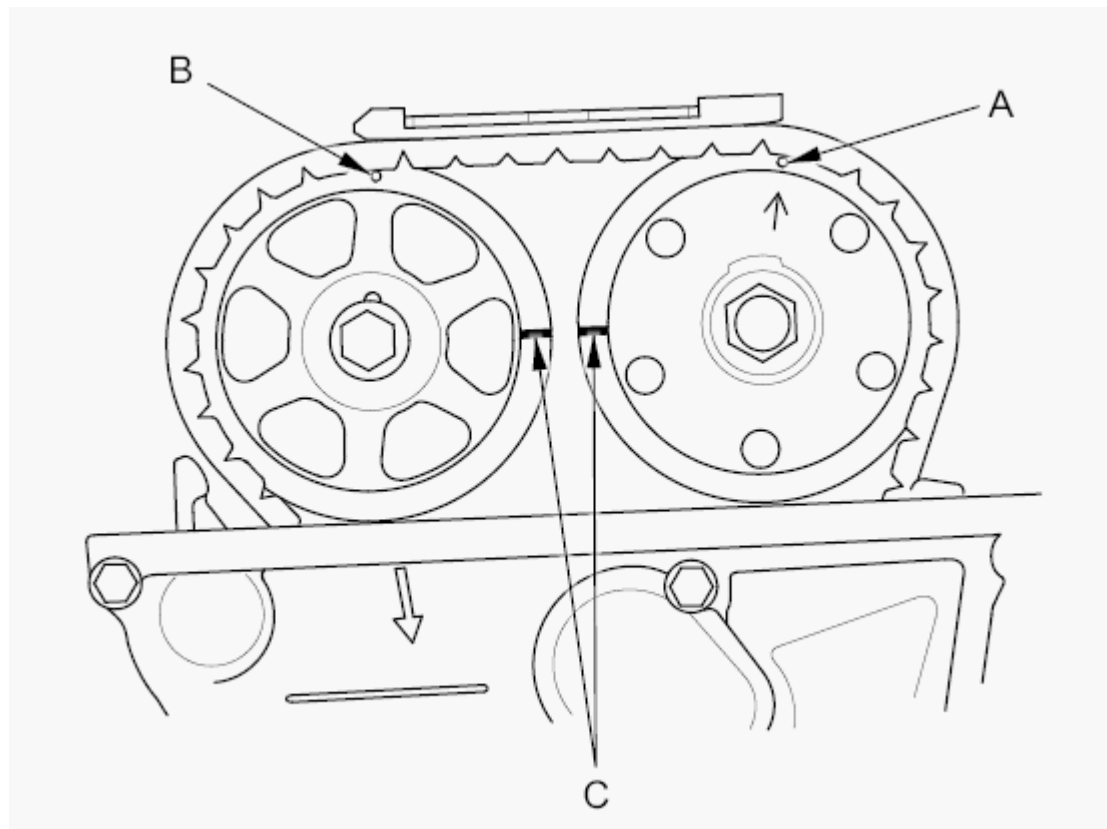

Fig. 92: Aligning the TDC Marks On The VTC Actuator And The Exhaust Camshaft Sprocket.
Courtesy of AMERICAN HONDA MOTOR CO., INC.

4. Remove the chain case cover.

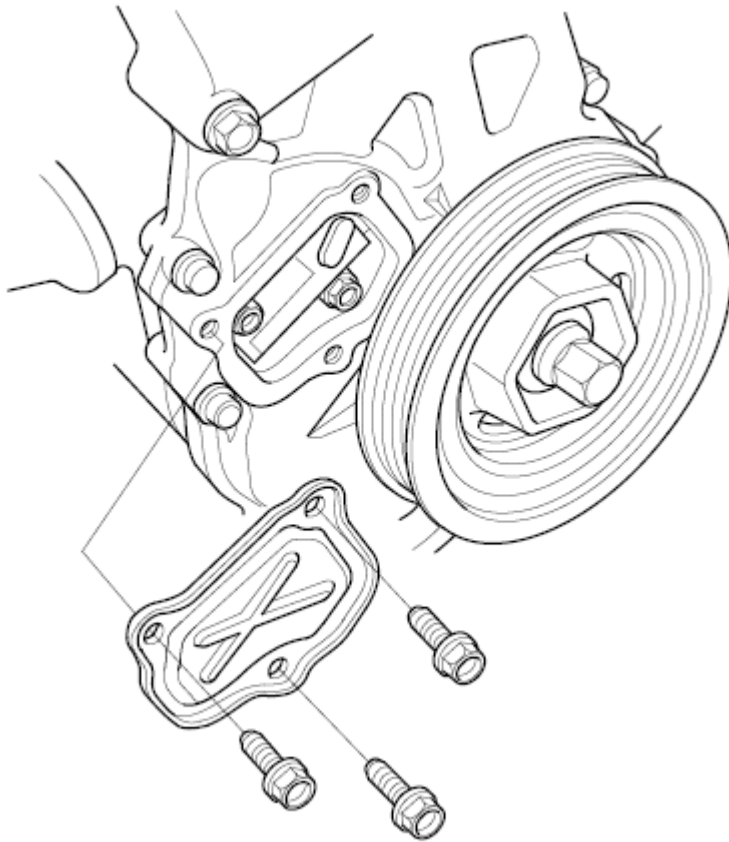

Fig. 93: Chain Case Cover And Bolts
Courtesy of AMERICAN HONDA MOTOR CO., INC.

5. Rotate the crankshaft counterclockwise and align the holes on the lock (A) and the auto-tensioner (B), then insert a 1.2 mm (3/64 in) diameter pin (C) into the holes.

NOTE: If the holes in the lock and the auto-tensioner do not align, continue to rotating the crankshaft counterclockwise until the holes align, then install the pin.

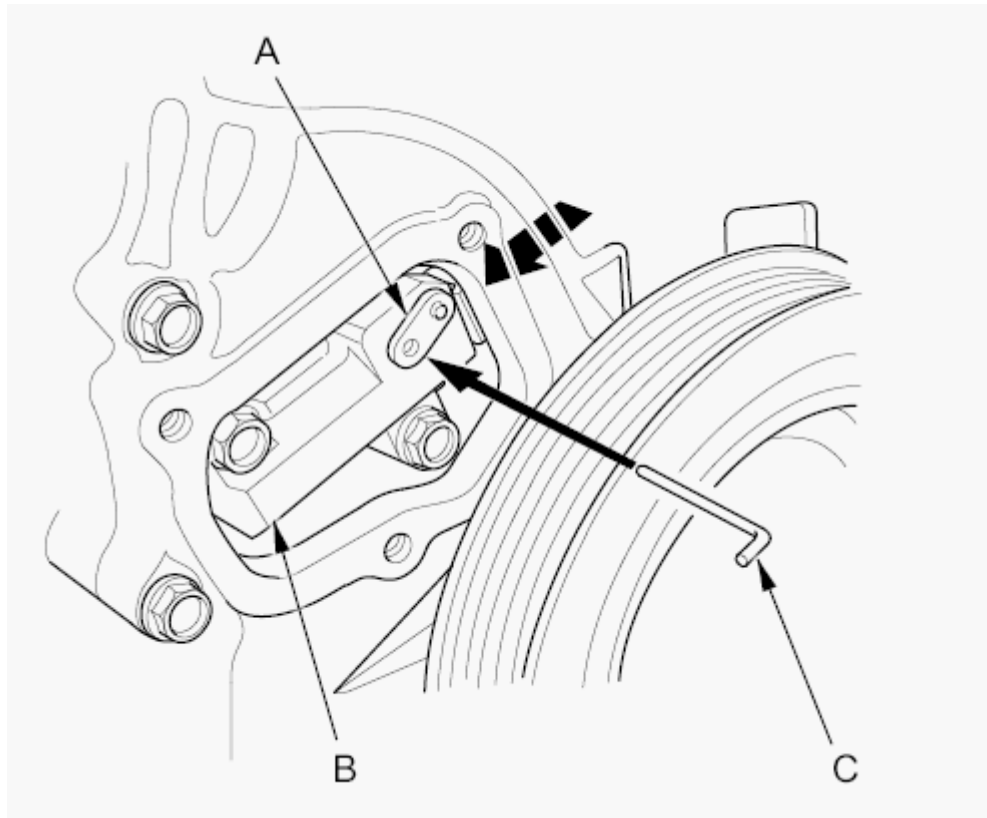

Fig. 94: Aligning The Holes On The Lock And The Auto-Tensioner
 Courtesy of AMERICAN HONDA MOTOR CO., INC.

6. Turn the crankshaft clockwise to secure the pin and the TDC on the No. 1 cylinder.
7. Loosen the rocker arm adjusting screws 2.
8. Remove the camshaft holder bolts 3.
9. Remove the five camshaft holders and cam chain guide B.
10. Carefully tip up the intake camshaft on the transmission side of the engine until there is enough slack in the chain to lift the chain off of the VTC actuator's teeth.
11. Remove the intake and exhaust camshafts while keeping some tension on the cam chain.
12. Secure the cam chain to the A/C compressor suction hose or the power steering hose with a wire tie to prevent the chain from falling down into the chain case.
13. Remove the VTC actuator and the exhaust camshaft sprocket.
14. Install the VTC actuator and the exhaust camshaft sprocket.

NOTE: Install the VTC actuator while in the unlocked position.

15. Apply new engine oil to the threads of the VTC actuator and the exhaust camshaft sprocket mounting bolts, then loosely install them.
16. Turn the VTC actuator clockwise until you hear it click. Make sure to lock the VTC actuator by turning it.
17. Remove the wire tie while keeping light tension on the cam chain.

18. Slide the intake and exhaust camshafts in at an angle to allow the cam chain to slip over the VTC actuator's teeth and the exhaust sprocket's teeth.
19. Line up the marks made in step 3 for each cam.
20. Apply new engine oil to the camshaft journals and lobes on both cams, and reinstall the five camshaft holders and cam chain guide B in place.
21. Tighten the camshaft holder bolts to the specified torque 8.
22. Hold the camshaft with an open-end wrench, then tighten the bolts.

Specified Torque**VTC Actuator Mounting Bolt:**

12 x 1.25 mm

113 N.m (11.5 kgf.m, 83 lbf.ft)

Exhaust Camshaft Sprocket Mounting Bolt:

10 x 1.25 mm

72 N.m (7.3 kgf.m, 53 lbf.ft)

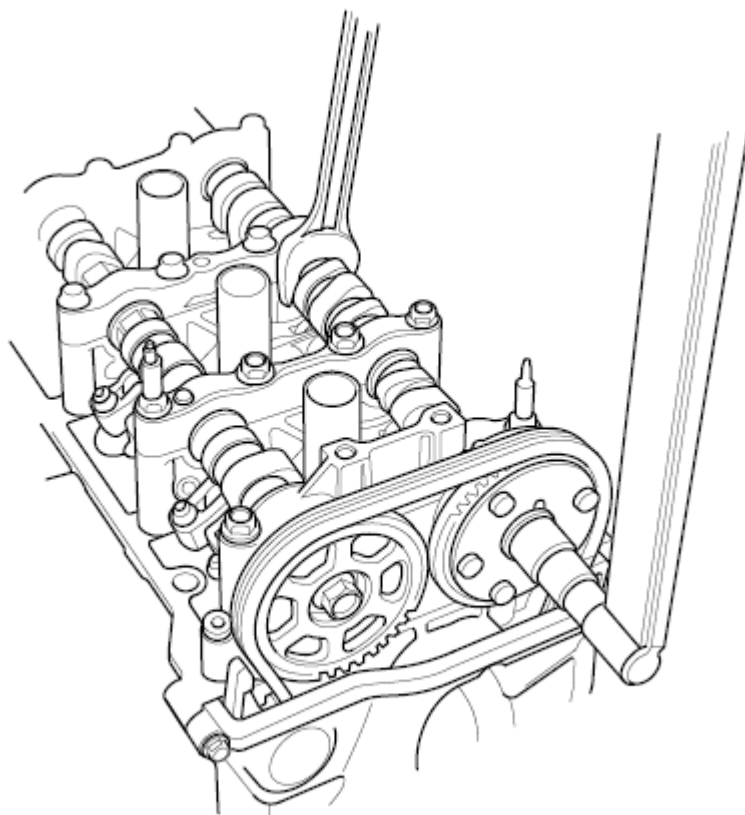

Fig. 95: Holding Camshaft With An Open-End Wrench
Courtesy of AMERICAN HONDA MOTOR CO., INC.

23. Remove the 1.2 mm (3/64 in) diameter pin from the auto-tensioner.

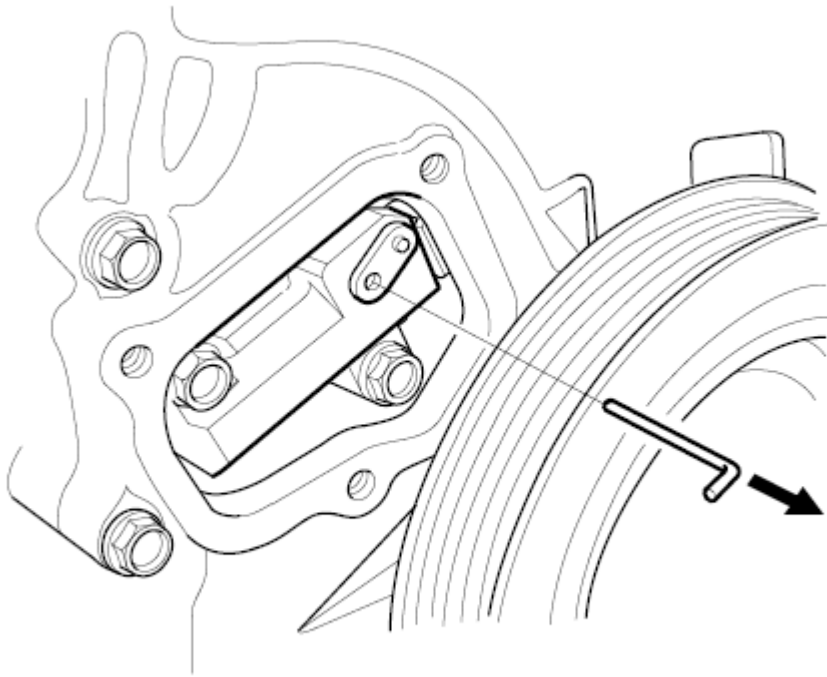

Fig. 96: Removing Pin From The Auto-Tensioner.
Courtesy of AMERICAN HONDA MOTOR CO., INC.

24. Remove all of the old liquid gasket from the chain case cover mating surfaces, the bolts, and the bolt holes.
25. Clean and dry the chain case cover mating surfaces.
26. Apply liquid gasket (P/N 08717-0004, 08718-0003, 08718-0004, or 08718-0009) evenly to the chain case mating surface of the chain case cover, and to the inside edge of the threaded bolt holes. Install the component within 5 minutes of applying the liquid gasket.

NOTE:

- Apply a 2.5 mm (0.098 in) diameter bead of liquid gasket along the broken line (A).
- If too much time has passed after applying the liquid gasket, remove the old liquid gasket and residue, then reapply new liquid gasket.

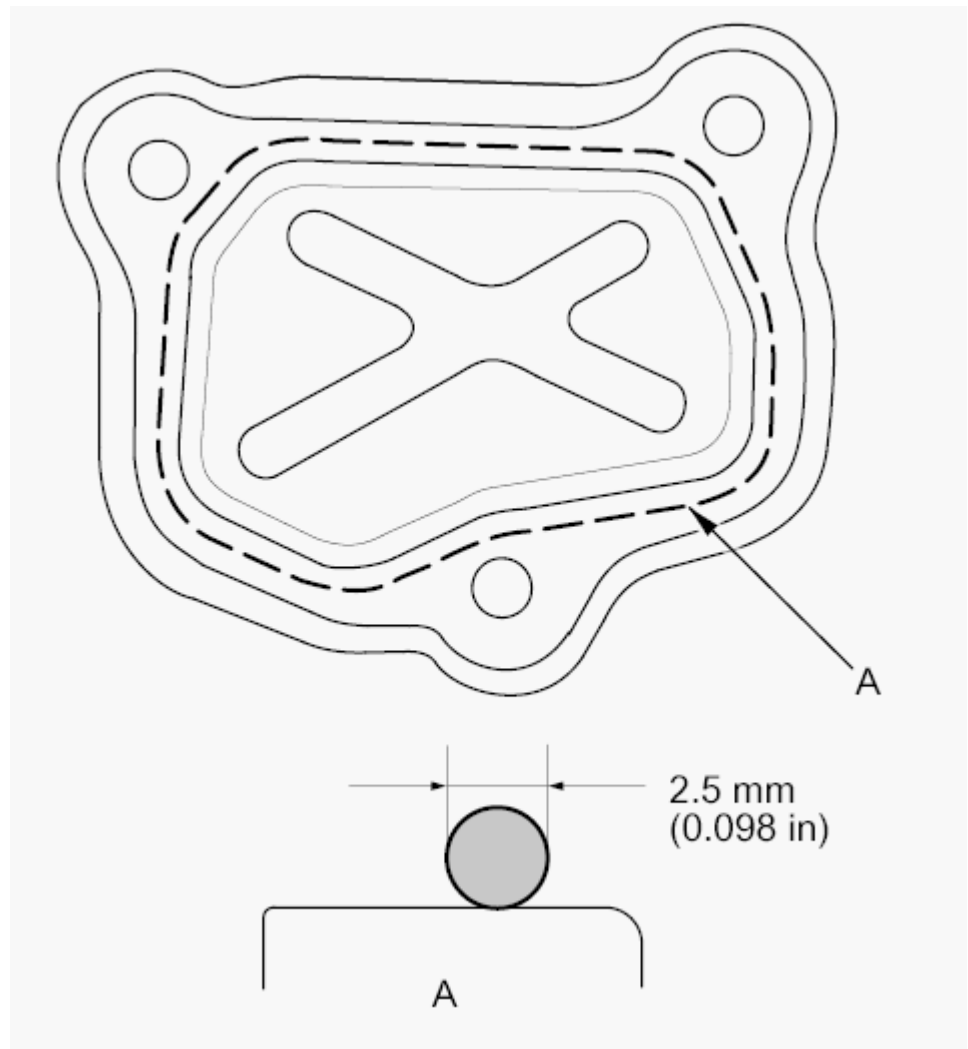

Fig. 97: Identifying Bead Of Liquid Gasket
Courtesy of AMERICAN HONDA MOTOR CO., INC.

27. Install the chain case cover.

NOTE:

- **Wait at least 30 minutes before filling the engine with oil.**
- **Do not run the engine for at least 3 hours after installing the chain case cover.**

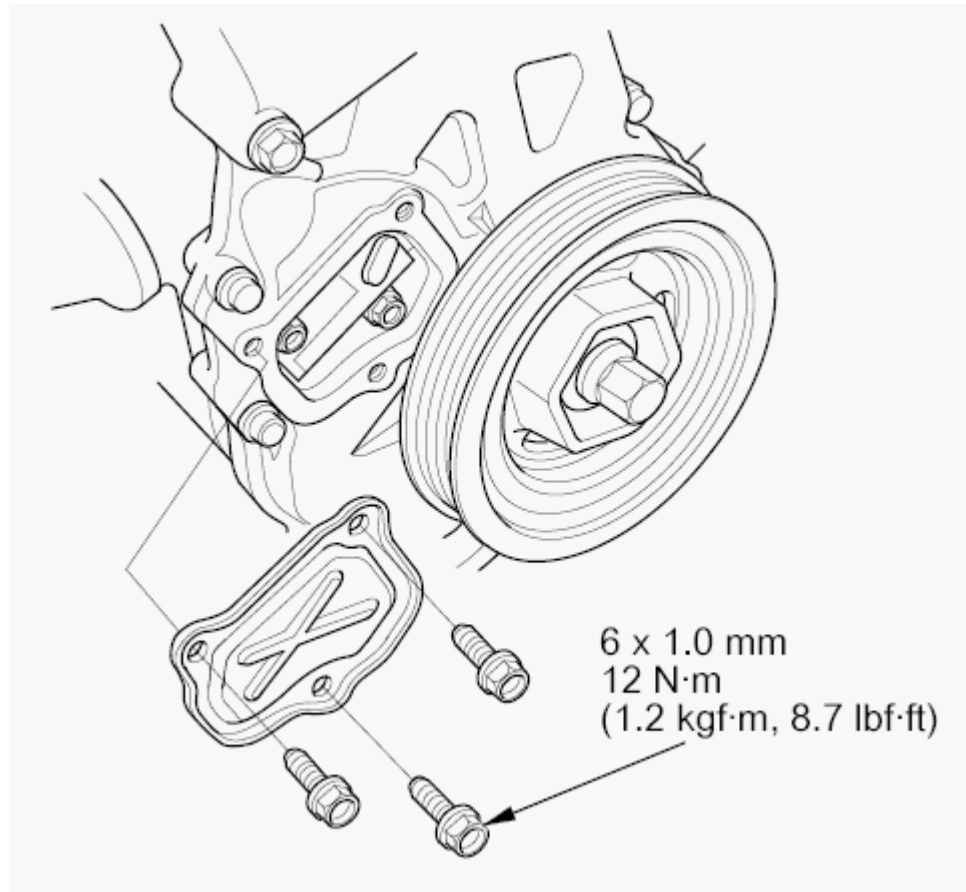

Fig. 98: Chain Case Cover

Courtesy of AMERICAN HONDA MOTOR CO., INC.

28. Adjust the valve clearance **Valve Clearance Adjustment**.
29. Install the cylinder head cover **Cylinder Head Cover Installation**.

CYLINDER HEAD INSPECTION FOR WARPAGE

1. Remove the cylinder head (see **CYLINDER HEAD REMOVAL**).
2. Inspect the camshaft (see **CAMSHAFT INSPECTION**).
3. Check the cylinder head for warpage. Measure along the edges, and three ways across the center.
 - If warpage is less than 0.05 mm (0.002 in) cylinder head resurfacing is not required.
 - If warpage is between 0.05 mm (0.002 in) and 0.2 mm (0.008 in), resurface the cylinder head.
 - Maximum resurface limit is 0.2 mm (0.008 in) based on a height of 104 mm (4.09 in).

Cylinder Head Height

Standard (New): 103.95-104.05 mm (4.093-4.096 in)

Service Limit: 103.8 mm (4.09 in)

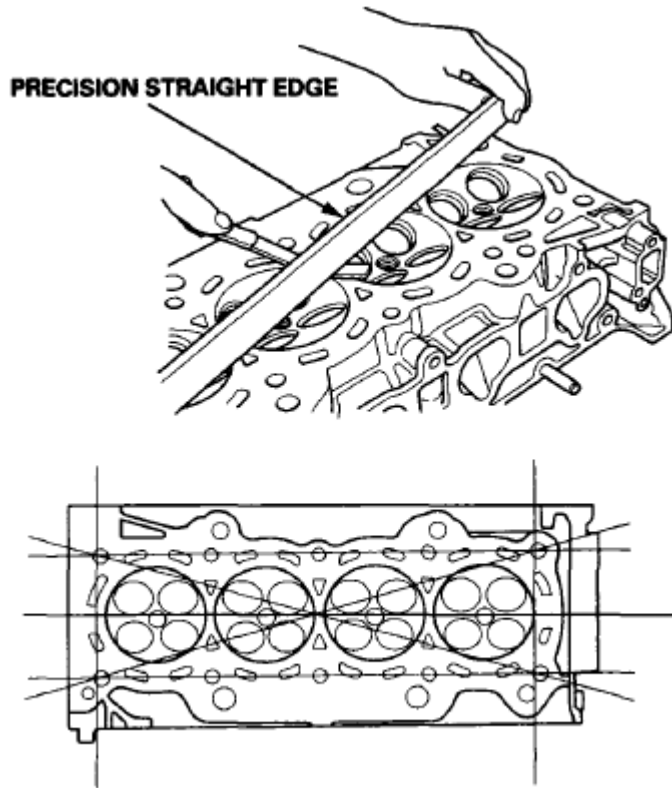

Fig. 99: Checking Cylinder Head For Warpage
 Courtesy of AMERICAN HONDA MOTOR CO., INC.

ROCKER ARM ASSEMBLY REMOVAL

1. Remove the cam chain (see **CAM CHAIN REMOVAL**).
2. Loosen the rocker arm adjusting screws (A).

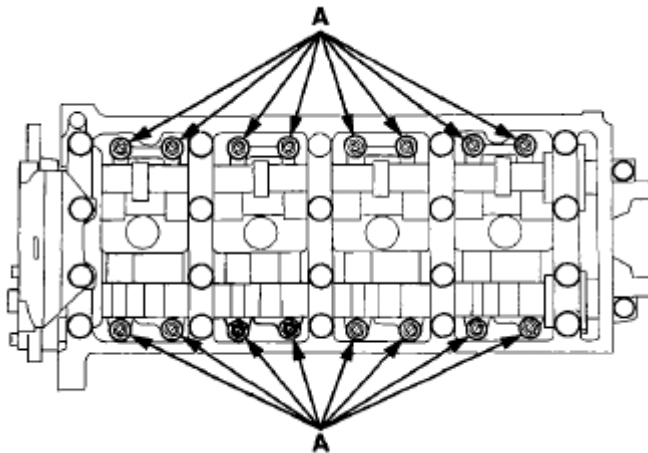

Fig. 100: Identifying Rocker Arm Adjusting Screws
 Courtesy of AMERICAN HONDA MOTOR CO., INC.

3. Remove the camshaft holder bolts. To prevent damaging the camshafts, loosen the bolts, in sequence, two turns at a time.

NOTE: Bolt (1) is not on all engines.

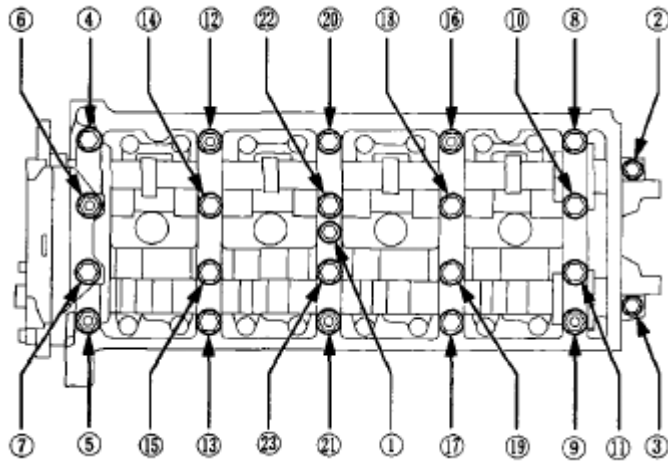

Fig. 101: Identifying Camshaft Holder Bolts
 Courtesy of AMERICAN HONDA MOTOR CO., INC.

4. Remove cam chain guide B, the camshaft holders, and the camshafts.
5. Insert the bolts (A) into the rocker shaft holder, then remove the rocker arm assembly (B).

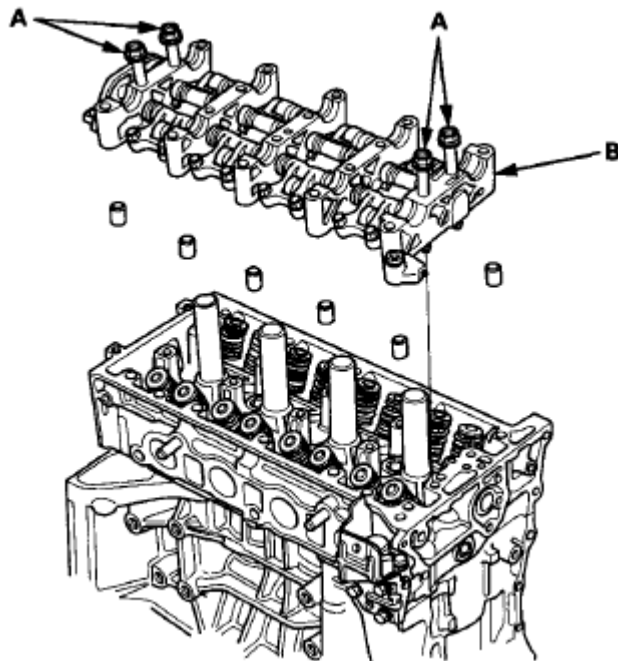

Fig. 102: Identifying Rocker Arm Assembly And Bolts
 Courtesy of AMERICAN HONDA MOTOR CO., INC.

ROCKER ARM AND SHAFT DISASSEMBLY/REASSEMBLY

NOTE:

- Identify each part as it is removed so that each item can be reinstalled in its original locations.
- Inspect the rocker arm shaft and rocker arms (see ROCKER ARM AND SHAFT INSPECTION).
- If reused, the rocker arms must be installed in the original locations.
- When removing, or installing the rocker arm assembly, do not remove the camshaft holder bolts. The bolts will keep the holders and rocker arms on the shaft.
- Prior to reassembling, clean all the parts in solvent, dry them, and apply lubricant to any contact points.
- Bundle the intake rocker arms with rubber bands to keep them together as a set.
- When replacing the intake rocker arm assembly, remove the fastening hardware from the new intake rocker arm assembly.

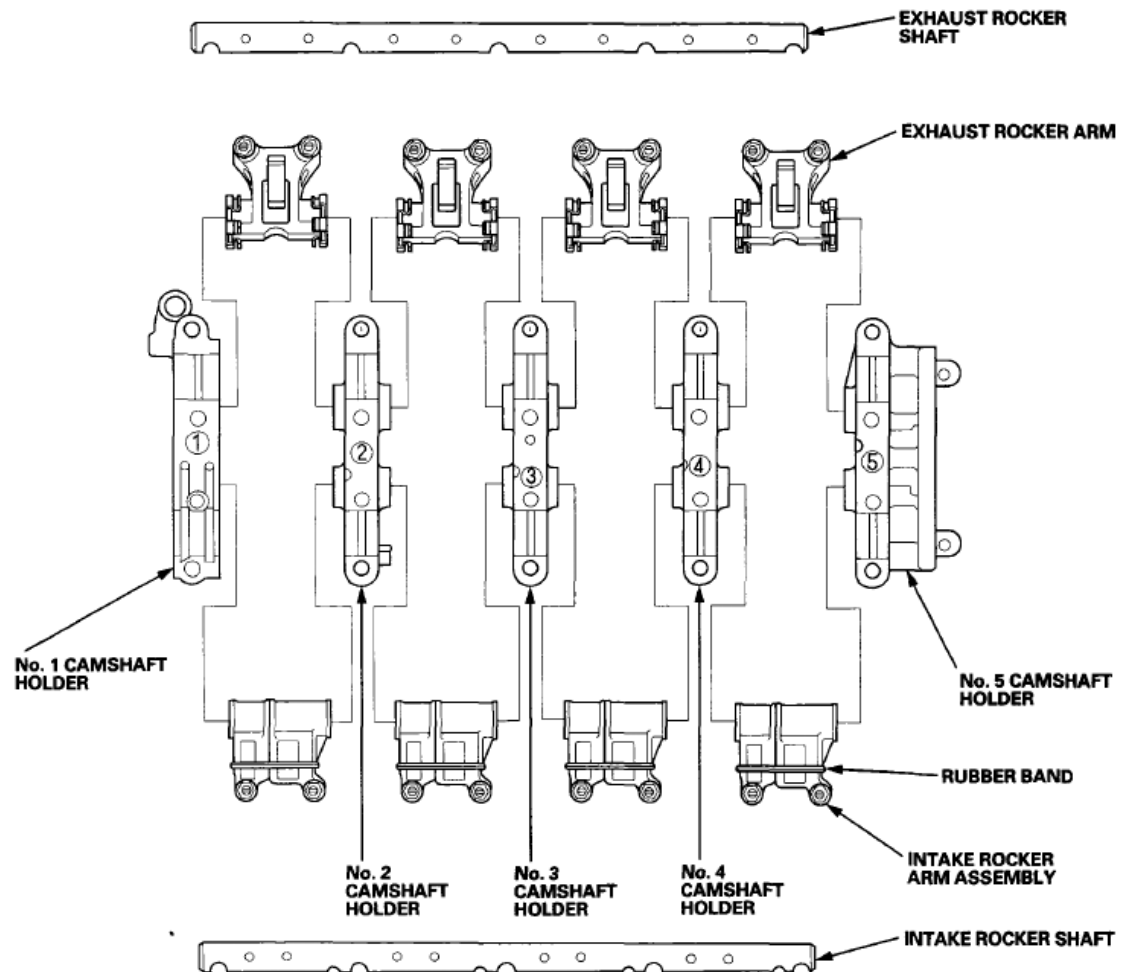

Fig. 103: Identifying Rocker Arm And Shaft Components

Courtesy of AMERICAN HONDA MOTOR CO., INC.

ROCKER ARM AND SHAFT INSPECTION

1. Remove the rocker arm assembly (see **ROCKER ARM ASSEMBLY REMOVAL**).
2. Disassemble the rocker arm assembly (see **ROCKER ARM AND SHAFT DISASSEMBLY/REASSEMBLY**).
3. Measure the diameter of the shaft at the first rocker location.

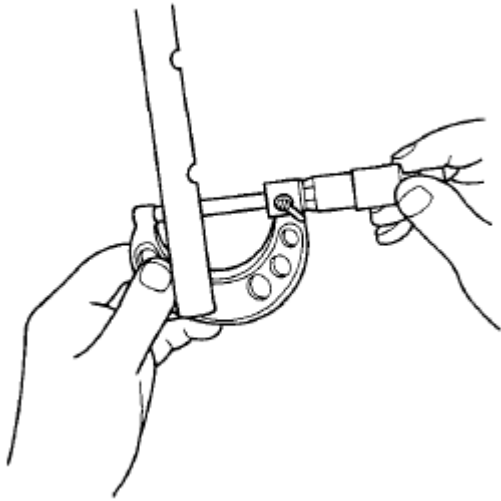

Fig. 104: Measuring Diameter Of Shaft At First Rocker
Courtesy of AMERICAN HONDA MOTOR CO., INC.

4. Zero the gauge (A) to the shaft diameter.

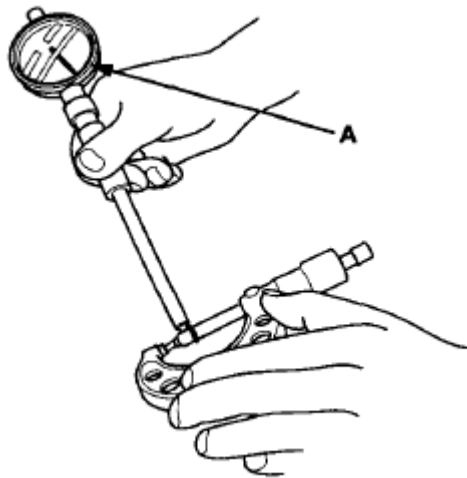

Fig. 105: Measuring Shaft Diameter Using Gauge
Courtesy of AMERICAN HONDA MOTOR CO., INC.

5. Measure the inside diameter of the rocker arm, and check it for an out-of-round condition.

Rocker Arm-to-Shaft Clearance

Standard (New):

Intake: 0.025-0.052 mm (0.0010-0.0020 in)

Exhaust: 0.018-0.056 mm (0.0007-0.0022 in)

Service Limit: 0.08 mm (0.003 in)



Fig. 106: Measuring Inside Diameter Of Rocker Arm
Courtesy of AMERICAN HONDA MOTOR CO., INC.

6. Repeat for all rocker arms and both shafts. If the clearance is beyond the service limit, replace the rocker shaft and all out of service limit rocker arms. If any VTEC rocker arm needs replacement, replace the rocker arms (primary and secondary), as a set.
7. Inspect the rocker arm pistons (A). Push on each piston manually. If it does not move smoothly, replace the rocker arm set.

NOTE: Apply oil to the pistons when reassembling.

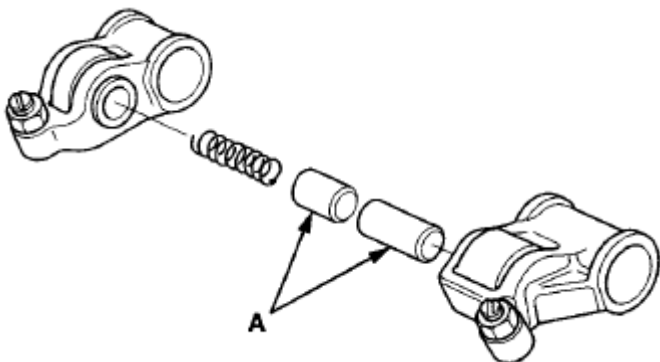

Fig. 107: Identifying Rocker Arm Pistons

Courtesy of AMERICAN HONDA MOTOR CO., INC.

8. Install the rocker arm assembly (see **ROCKER ARM ASSEMBLY INSTALLATION**).

CAMSHAFT INSPECTION**NOTE: Do not rotate the camshaft during inspection.**

1. Remove the rocker arm assembly (see **ROCKER ARM ASSEMBLY REMOVAL**).
2. Put the rocker shaft holders, camshaft, and camshaft holders on the cylinder head, then tighten the bolts, in sequence, to the specified torque.

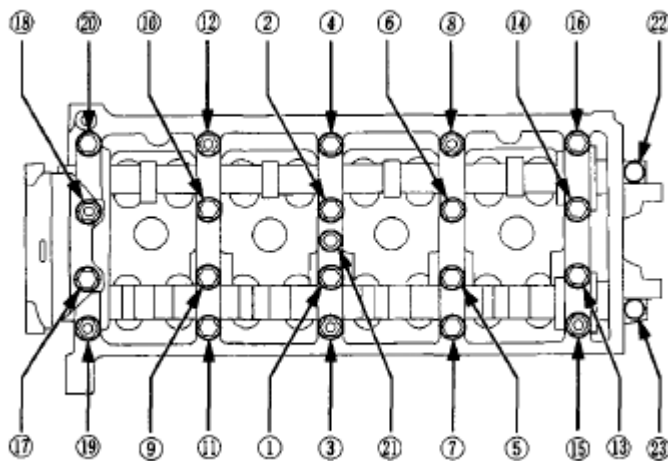
NOTE: If the engine does not have bolt @, skip it and continue the torque sequence.**Specified Torque****8x1.25 mm****22 N.m (2.2 kgf.m, 16 lbf.ft)****6 x 1.0 mm****12 N.m (1.2 kgf.m, 8.8 lbf.ft)****6 x 1.0 mm Bolts: (21), (22), (23)****Fig. 108: Identifying Cylinder Head Bolts Tighten Sequence**

Courtesy of AMERICAN HONDA MOTOR CO., INC.

3. Seat the camshaft by pushing it away from the camshaft pulley end of the cylinder head.

4. Zero the dial indicator against the end of the camshaft, then push the camshaft back and forth, and read the end play. If the end play is beyond the service limit, replace the cylinder head and recheck. If it is still beyond the service limit, replace the camshaft.

Camshaft End Play

Standard (New): 0.05-0.20 mm (0.002-0.008 in)

Service Limit: 0.4 mm (0.02 in)

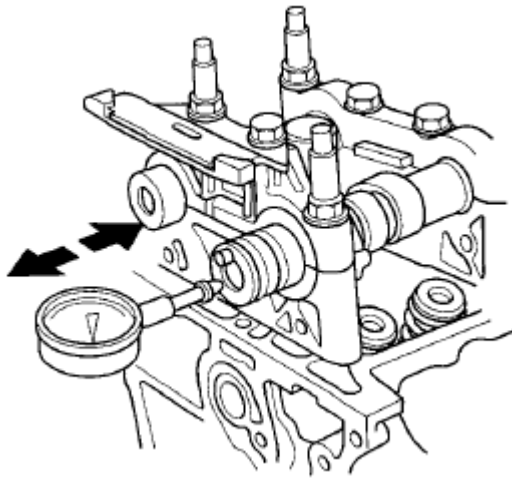

Fig. 109: Measuring Camshaft End Play

Courtesy of AMERICAN HONDA MOTOR CO., INC.

5. Unscrew the camshaft holder bolts two turns at a time, in a crisscross pattern. Then remove the camshaft holders from the cylinder head.
6. Lift the camshafts out of the cylinder head, wipe them clean, then inspect the lift ramps. Replace the camshaft if any lobes are pitted, scored, or excessively worn.
7. Clean the camshaft journal surfaces in the cylinder head, then set the camshafts back in place. Place a plastigage strip across each journal.
8. Install the camshaft holders, then tighten the bolts to the specified torque as shown in step 2.
9. Remove the camshaft holders. Measure the widest portion of plastigage on each journal.
 - If the camshaft-to-holder clearance is within limits, go to step 11.
 - If the camshaft-to-holder clearance is beyond the service limit, and the camshaft has been replaced, replace the cylinder head.
 - If the camshaft-to-holder clearance is beyond the service limit, and the camshaft has not been replaced, go to step 10.

Camshaft-to-Holder Oil Clearance Standard (New):

No. 1 Journal: 0.030-0.069 mm (0.0012-0.0027 in)

No. 2, 3, 4, 5 Journals: 0.060-0.099 mm (0.0024-0.0039 in)

Service Limit: 0.15 mm (0.006 in)

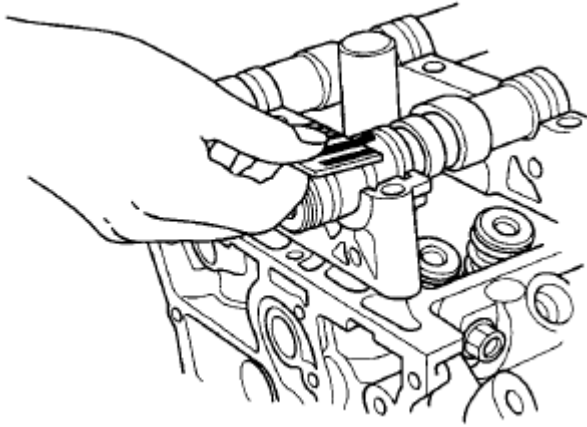

Fig. 110: Measuring Widest Portion Of Plastigage On Journal
Courtesy of AMERICAN HONDA MOTOR CO., INC.

10. Check the total runout with the camshaft supported on V-blocks.
 - If the total runout of the camshaft is within the service limit, replace the cylinder head.
 - If the total runout is beyond the service limit, replace the camshaft, and recheck the camshaft-to-holder oil clearance. If the oil clearance is still out of tolerance, replace the cylinder head.

Camshaft Total Runout

Standard (New): 0.03 mm (0.001 in) max.

Service Limit: 0.04 mm (0.002 in)

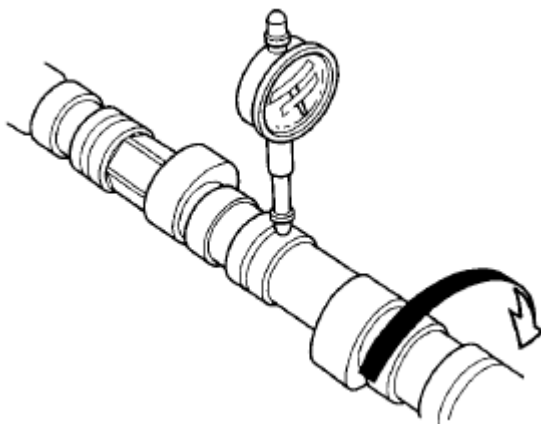

Fig. 111: Checking Camshaft Total Runout
Courtesy of AMERICAN HONDA MOTOR CO., INC.

11. Measure cam lobe height.

Cam Lobe Height Standard (New):

CAM LOBE HEIGHT STANDARD CHART

	INTAKE	EXHAUST
PRI	34.263 mm (1.3489 in)	34.092 mm (1.3422 in)
SEC	29.638 mm (1.1668 in)	

PRI: Primary SEC: Secondary C/C: Cam Chain

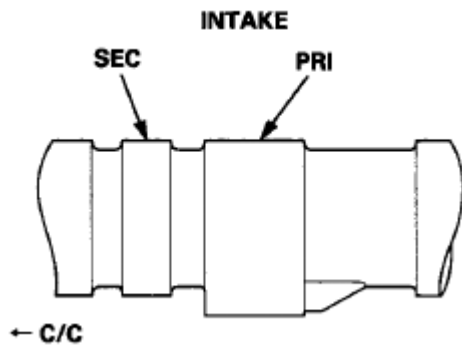

Fig. 112: Measuring Cam Lobe Height
Courtesy of AMERICAN HONDA MOTOR CO., INC.

VALVE, SPRING, AND VALVE SEAL REMOVAL

Special Tools Required

Valve Spring Compressor Attachment 07757-PJ1010A

Identify the valves and valve springs as they are removed so that each item can be reinstalled in its original position.

1. Remove the cylinder head (see **CYLINDER HEAD REMOVAL**).
2. Remove the rocker arm assembly (see **ROCKER ARM ASSEMBLY REMOVAL**).
3. Using an appropriate-sized socket (A) and a plastic mallet (B), lightly tap the valve retainer to loosen the valve cotters.

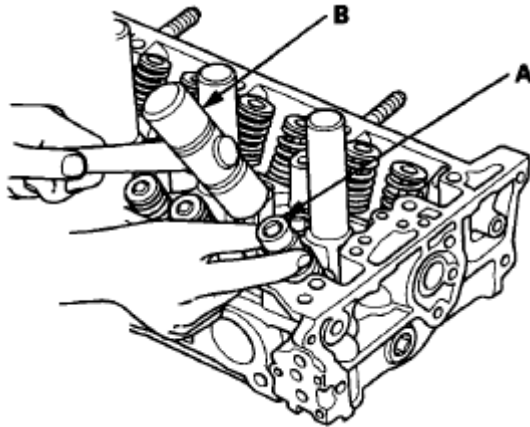

Fig. 113: Tapping Valve Retainer

Courtesy of AMERICAN HONDA MOTOR CO., INC.

4. Install the valve spring compressor attachment and the valve spring compressor. Compress the spring and remove the valve cotters.

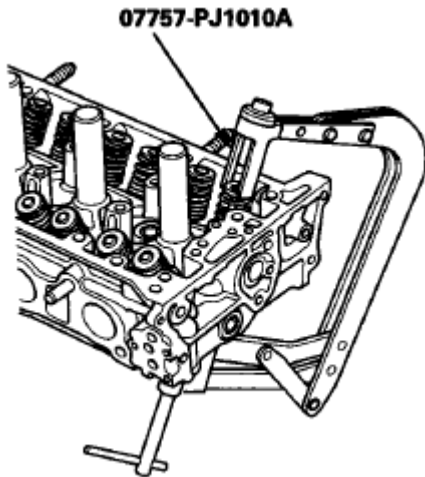

Fig. 114: Removing Valve Cotters

Courtesy of AMERICAN HONDA MOTOR CO., INC.

5. Remove the special tools, then remove the valve retainer and the valve spring.
6. Install the valve guide seal remover.

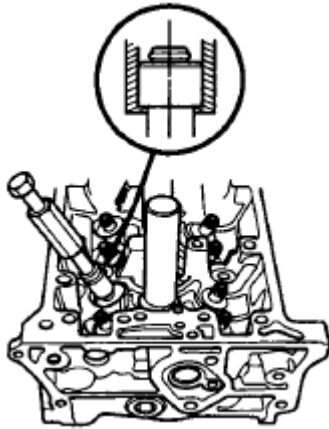

Fig. 115: Installing Valve Guide Seal Remover
Courtesy of AMERICAN HONDA MOTOR CO., INC.

7. Remove the valve seal.

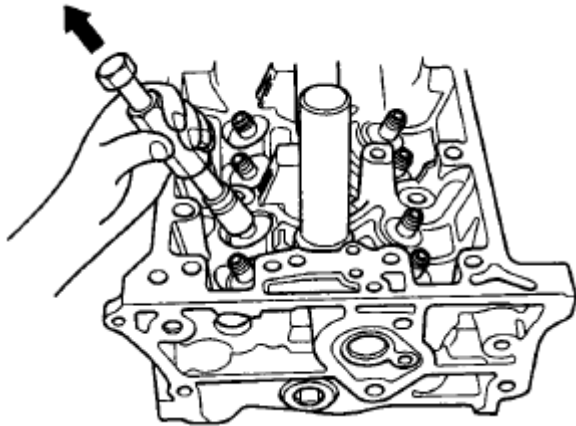

Fig. 116: Removing Valve Seal
Courtesy of AMERICAN HONDA MOTOR CO., INC.

8. Remove the valve spring seat.

VALVE INSPECTION

1. Remove the valves (see **VALVE, SPRING, AND VALVE SEAL REMOVAL**).
2. Measure the valve in these areas.

Intake Valve Dimensions

A Standard (New): 34.85-35.15 mm (1.372-1.384 in)

B Standard (New): 108.7-109.5 mm (4.280-4.311 in)

C Standard (New): 5.475-5.485 mm (0.2156-0.2159 in)

C Service Limit: 5.445 mm (0.2144 in)

Exhaust Valve Dimensions

A Standard (New): 29.85-30.15 mm (1.175-1.187 in)

B Standard (New): 108.3-109.1 mm (4.264-4.295 in)

C Standard (New): 5.450-5.460 mm (0.2146-0.2150 in)

C Service Limit: 5.42 mm (0.213 in)

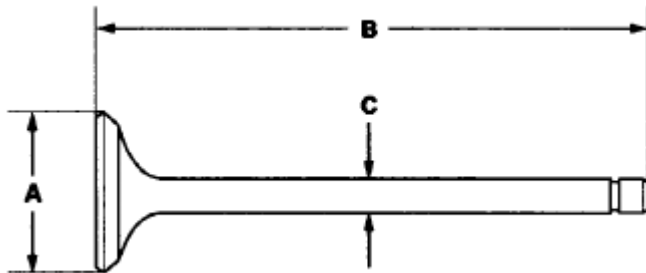

Fig. 117: Identifying Valve Dimension

Courtesy of AMERICAN HONDA MOTOR CO., INC.

VALVE STEM-TO-GUIDE CLEARANCE INSPECTION

1. Remove the valves (see **VALVE, SPRING, AND VALVE SEAL REMOVAL**).
2. Subtract the O.D. of the valve stem, measured with a micrometer, from the I.D. of the valve guide, measured with an inside micrometer or ball gauge.

Take the measurements in three places along the valve stem and three places inside the valve guide.

The difference between the largest guide measurement and the smallest stem measurement should not exceed the service limit.

Intake Valve Stem-to-Guide Clearance

Standard (New): 0.030-0.055 mm (0.0012-0.0022 in)

Service Limit: 0.08 mm (0.003 in)

Exhaust Valve Stem-to-Guide Clearance

Standard (New): 0.055-0.080 mm (0.0022-0.0031 in)

Service Limit: 0.11 mm (0.004 in)

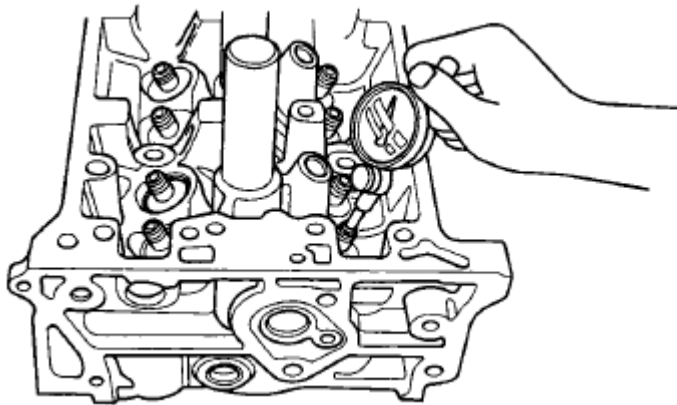

Fig. 118: Inspecting Valve Stem-To-Guide Clearance
Courtesy of AMERICAN HONDA MOTOR CO., INC.

VALVE GUIDE REPLACEMENT

Special Tools Required

- Valve Guide Driver, 5.35 x 9.7 mm 07742-0010100
 - Valve Guide Reamer, 5.5 mm 07HAH-PJ7A100
1. Inspect the valve stem-to-guide clearance (see **VALVE INSPECTION**).
 2. As illustrated, use a commercially available air-impact valve guide driver (A) modified to fit the diameter of the valve guides. In most cases, the same procedure can be done using the special tool and a conventional hammer.

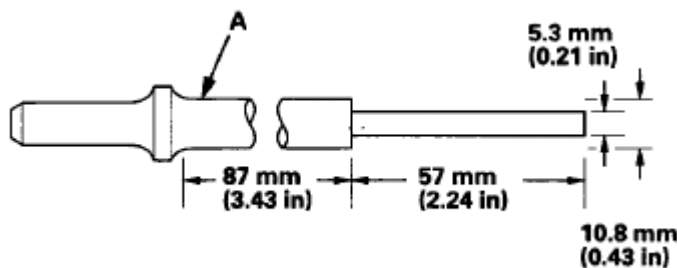

Fig. 119: Identifying Air-Impact Valve Guide Driver Dimension
Courtesy of AMERICAN HONDA MOTOR CO., INC.

3. Select the proper replacement guides, and chill them in the freezer section of a refrigerator for about an hour.
4. Use a hot plate or oven to evenly heat the cylinder head to 300 °F (150 °C). Monitor the temperature with a cooking thermometer. Do not get the head hotter than 300 °F (150 °C); excessive heat may loosen the valve seats.

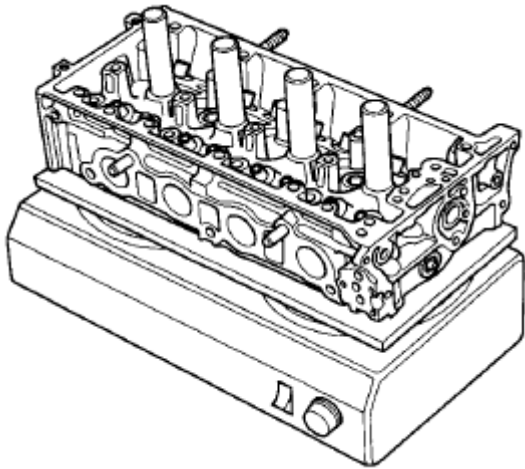

Fig. 120: Identifying Valve Seats

Courtesy of AMERICAN HONDA MOTOR CO., INC.

5. Working from the camshaft side, use the driver and an air hammer to drive the guide about 2 mm (0.1 in) towards the combustion chamber. This will knock off some of the carbon and make removal easier. Hold the air hammer directly in line with the valve guide to prevent damaging the driver.
6. Turn the head over, and drive the guide out toward the camshaft side of the head.

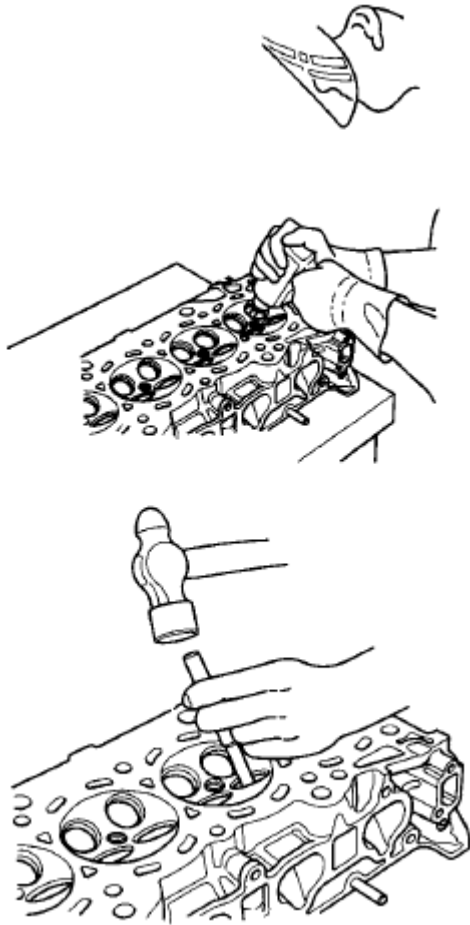

Fig. 121: Removing Valve Guide

Courtesy of AMERICAN HONDA MOTOR CO., INC.

7. If a valve guide still will not move, drill it out with a 8 mm (5/16 in) bit, then try again.

NOTE: **Drill out of guides only in extreme cases; you could damage the cylinder head if the guide breaks.**

8. Remove the new guide(s) from the freezer, one at a time, as you need them.
9. Apply a thin coat of clean engine oil to the outside of the new valve guide. Install the guide from the camshaft side of the head; use the 5.5 mm valve guide driver to drive the guide in to the specified installed height (A) of the guide (B). If you have all 16 guides to do, you may have to reheat the head.

Valve Guide Installed Height

Intake: 15.2-16.2 mm (0.60-0.64 in)

Exhaust: 15.5-16.5 mm (0.61 -0.65 in)

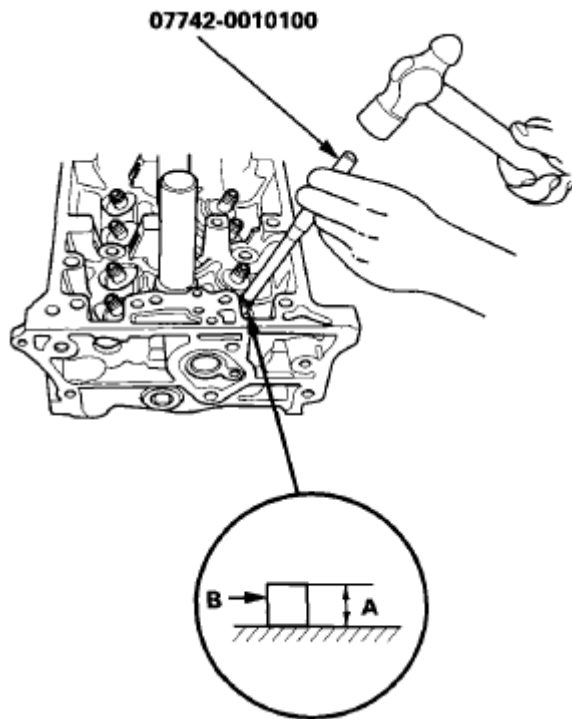

Fig. 122: Identifying Valve Guide Height
 Courtesy of AMERICAN HONDA MOTOR CO., INC.

10. Coat both reamer and the valve guide with cutting oil.
11. Rotate the reamer clockwise to the full length of the valve guide bore.

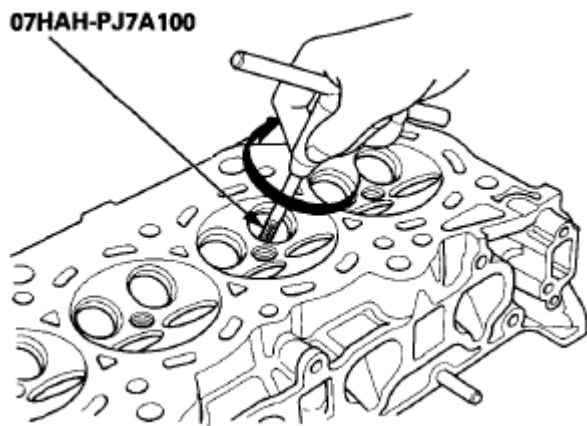

Fig. 123: Rotating Valve Guide
 Courtesy of AMERICAN HONDA MOTOR CO., INC.

12. Continue to rotate the reamer clockwise while removing it from the bore.
13. Thoroughly wash the guide with detergent and water to remove any cutting residue.
14. Check the clearances with a valve (see **VALVE INSPECTION**). Verify that a valve slides into the intake and exhaust valve guides without sticking.

15. Inspect the valve seat. If necessary renew the valve seat using a valve seat cutter (see **VALVE SEAT RECONDITIONING**).

VALVE SEAT RECONDITIONING

1. Inspect the valve stem-to-guide clearance (see **VALVE INSPECTION**). If the valve guides are worn, replace them (see **VALVE GUIDE REPLACEMENT**) before cutting the valve seats.
2. Renew the valve seats in the cylinder head using a valve seat cutter.

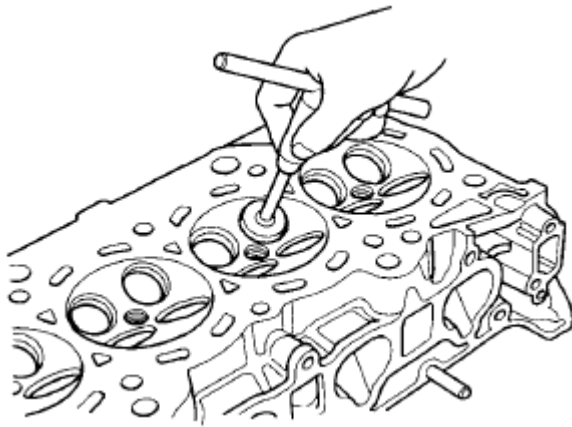

Fig. 124: Adjusting Valve Seats

Courtesy of AMERICAN HONDA MOTOR CO., INC.

3. Carefully cut a 45 ° seat, removing only enough material to ensure a smooth and concentric seat.
4. Bevel the upper and lower edges at the angles shown in the illustration. Check the width of the seat and adjust accordingly.



Fig. 125: Checking Width Of Seat

Courtesy of AMERICAN HONDA MOTOR CO., INC.

5. Make one more very light pass with the 45 ° cutter to remove any possible burrs caused by the other cutters.

Valve Seat Width

Standard (New): 1.25-1.55 mm (0.049-0.061 in)

Service Limit: 2.00 mm (0.079 in)

6. After resurfacing the seat, inspect for even valve seating. Apply Prussian Blue compound (A) to the valve face. Insert the valve in its original location in the head, then lift it and snap it closed against the seat several times.

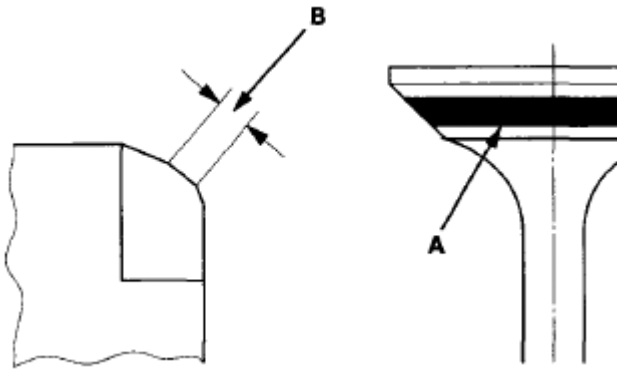

Fig. 126: Inspecting Valve Seating

Courtesy of AMERICAN HONDA MOTOR CO., INC.

7. The actual valve seating surface (B), as shown by the blue compound, should be centered on the seat.
- If it is too high (closer to the valve stem), you must make a second cut with the 67.5 ° cutter to move it down, then one more cut with the 45 ° cutter to restore seat width.
 - If it is too low (close to the valve edge), you must make a second cut with the 35 ° cutter (intake side) or the 30 ° cutter (exhaust side) to move it up, then make one more cut with the 45 ° cutter to restore seat width.

NOTE: The final cut should always be made with the 45 ° cutter.

8. Insert the intake and exhaust valves in the head, and measure valve stem installed height (A).

Intake Valve Stem Installed Height

Standard (New): 44.0-44.5 mm (1.73-1.75 in)

Service Limit: 44.7 mm (1.76 in)

Exhaust Valve Stem Installed Height

Standard (New): 44.1-44.6 mm (1.74-1.76 in)

Service Limit: 44.8 mm (1.76 in)

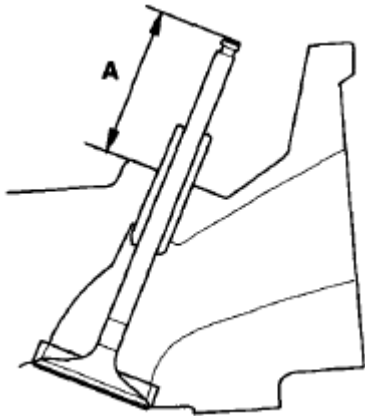

Fig. 127: Measuring Valve Stem Installed Height
 Courtesy of AMERICAN HONDA MOTOR CO., INC.

- If valve stem installed height is beyond the service limit, replace the valve and recheck. If it is still beyond the service limit, replace the cylinder head; the valve seat in the head is too deep.

VALVE, SPRING, AND VALVE SEAL INSTALLATION

Special Tools Required

- Stem Seal Driver, 30 mm 07PAD-0010000
 - Valve Spring Compressor Attachment 07757-PJ1010A
- Coat the valve stems with engine oil. Install the valves in the valve guides.
 - Check that the valves move up and down smoothly.
 - Install the spring seats on the cylinder head.
 - Install the new valve seals (A) using the valve guide seal installer (B).

NOTE: The exhaust valve seal (C) has a black spring (D), and the intake valve seal (E) has a white spring (F). They are not interchangeable.

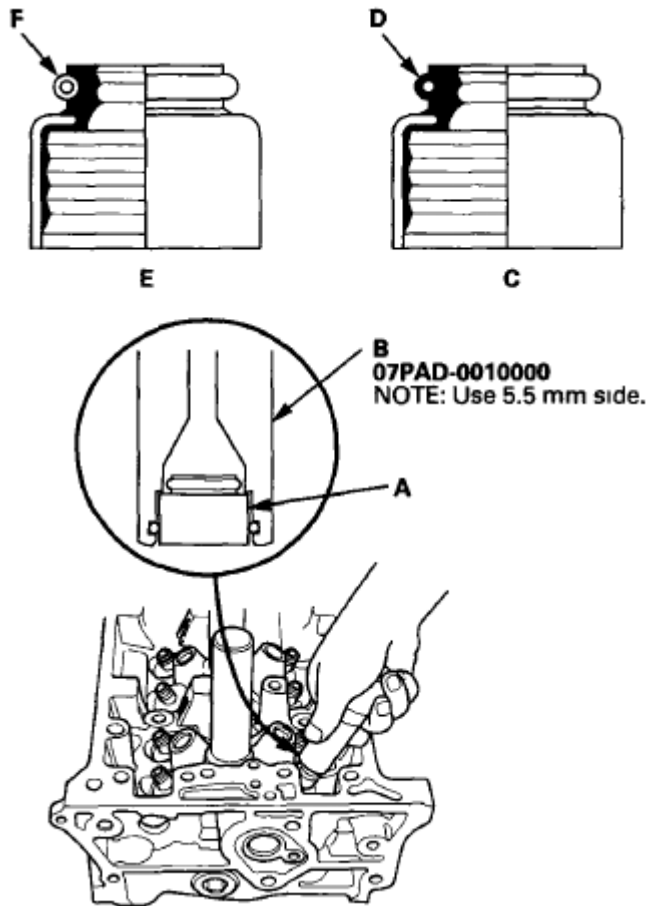

Fig. 128: Installing Valve Seals

Courtesy of AMERICAN HONDA MOTOR CO., INC.

5. Install the valve spring and valve retainer. Place the end of the valve spring with the closely wound coils toward the cylinder head.
6. Install the valve spring compressor attachment and the valve spring compressor. Compress the spring and install the valve cotters.

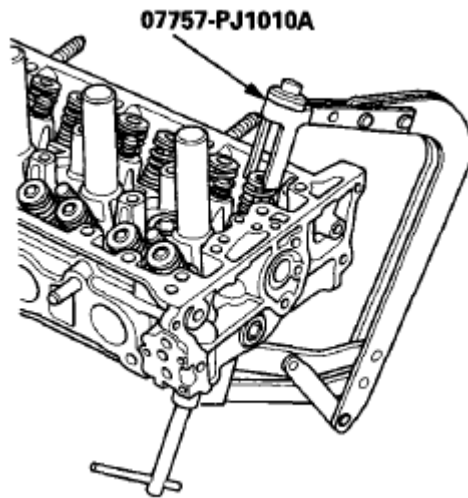

Fig. 129: Installing Valve Spring Compressor Attachment And Valve Spring Compressor
Courtesy of AMERICAN HONDA MOTOR CO., INC.

7. Remove the valve spring compressor and the attachment.
8. Lightly tap the end of each valve stem two or three times with a plastic mallet (A) to ensure proper seating of the valve and valve keepers. Tap the valve stem only along its axis so you do not bend the stem.

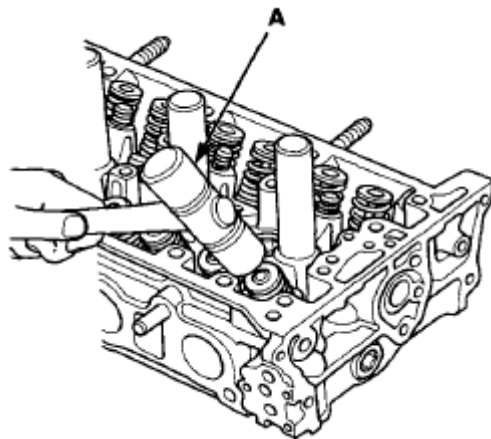

Fig. 130: Tapping Valve Stem
Courtesy of AMERICAN HONDA MOTOR CO., INC.

ROCKER ARM ASSEMBLY INSTALLATION

1. Reassemble the rocker arm assembly (see **ROCKER ARM AND SHAFT DISASSEMBLY/REASSEMBLY**).
2. Clean and dry the No. 5 rocker shaft holder mating surface.
3. Apply liquid gasket (P/N 08717-0004, 08718-0003, or 08718-0009) to the cylinder head mating surface of the No. 5 rocker shaft holder and to the inside edge of the bolt holes. Install the component within 5 minutes of applying the liquid gasket.

NOTE:

- Apply a 3 mm (0.12 in) diameter bead of liquid gasket along the broken line (A).
- If too much time has passed after applying the liquid gasket, remove the old liquid gasket and residue, then reapply new liquid gasket.

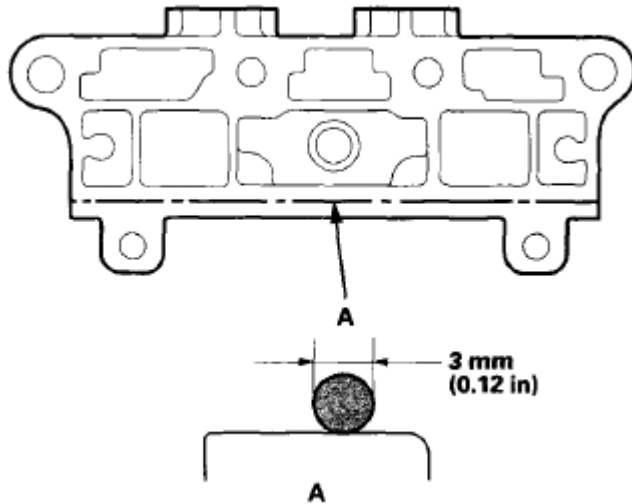

Fig. 131: Identifying Rocker Arm Broken Line
 Courtesy of AMERICAN HONDA MOTOR CO., INC.

4. Insert the bolts (A) into the rocker shaft holder, then install the rocker arm assembly (B) on the cylinder head.

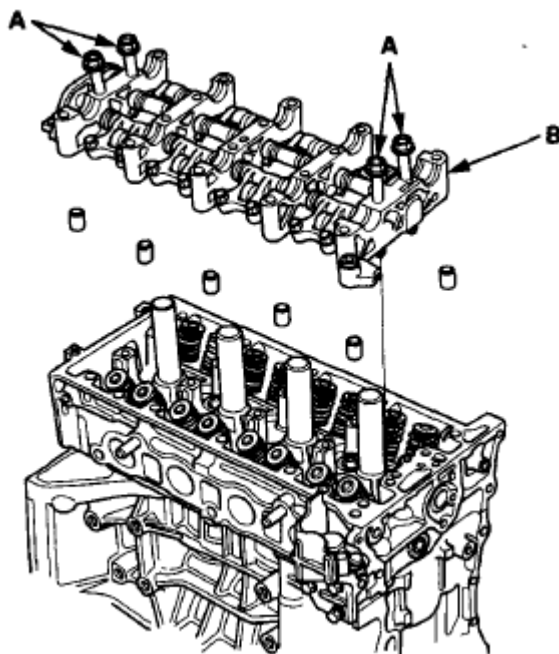

Fig. 132: Identifying Rocker Arm Assembly And Cylinder Head
 Courtesy of AMERICAN HONDA MOTOR CO., INC.

5. Remove the bolts from the rocker shaft holder.
6. Make sure the punch marks on the variable valve timing control (VTC) actuator and exhaust camshaft sprocket are facing up, then set the camshafts (A) in the holder.

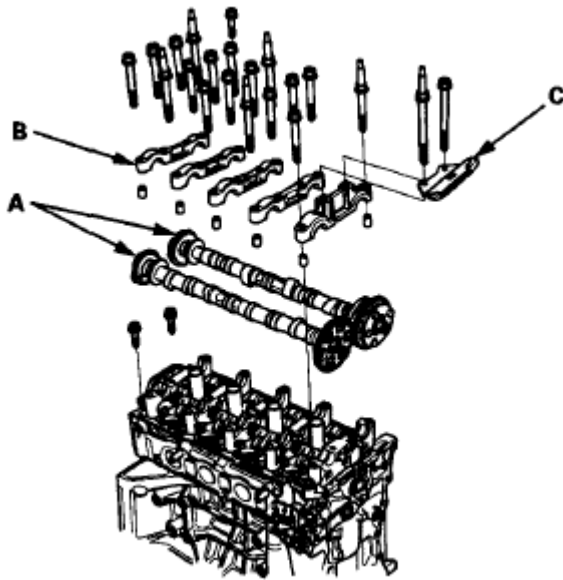

Fig. 133: Identifying Variable Valve Timing Control Actuator And Camshaft
 Courtesy of AMERICAN HONDA MOTOR CO., INC.

7. Set the camshaft holders (B) and cam chain guide B (C) in place.
8. Apply new engine oil to the bolt threads and flange. Tighten the bolts to the specified torque.

NOTE: If the engine does not have bolt (21), skip it and continue the torque sequence.

Specified Torque

8 x 1.25 mm

22 N.m (2.2 kgf.m, 16 lbf.ft)

6 x 1.0 mm

12 N.m (1.2 kgf.m, 8.8 lbf.ft)

6 x 1.0 mm Bolts: (21), (22), (23)

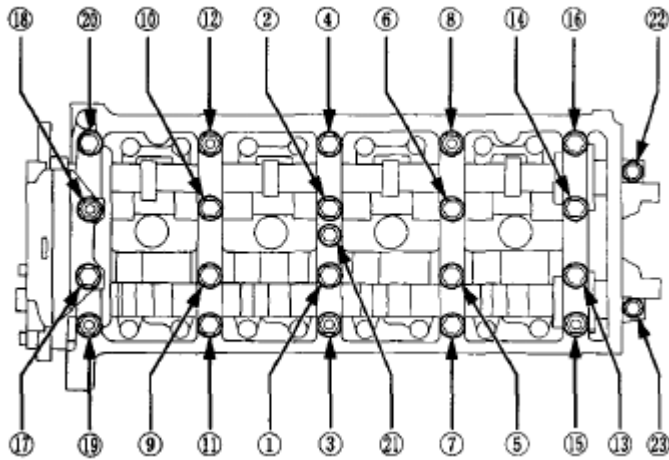

Fig. 134: Identifying Camshaft Bolts Tighten Sequence
 Courtesy of AMERICAN HONDA MOTOR CO., INC.

9. Install the cam chain (see CAM CHAIN INSTALLATION), and adjust the valve clearance (see VALVE CLEARANCE ADJUSTMENT).

CYLINDER HEAD INSTALLATION

1. Clean the cylinder head and block surface.
2. Install a new coolant separator (A) in the engine block whenever the engine block is replaced.

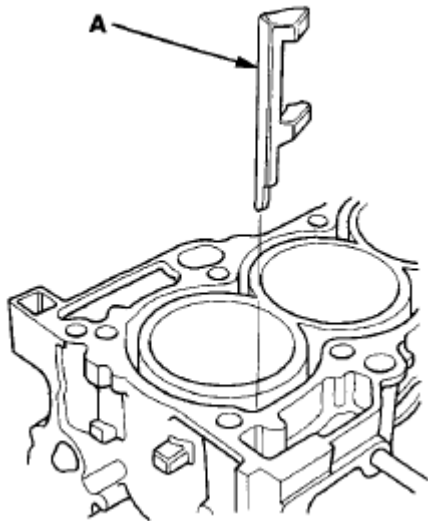

Fig. 135: Identifying Coolant Separator
 Courtesy of AMERICAN HONDA MOTOR CO., INC.

3. Install the new cylinder head gasket (A) and dowel pins (B) on the engine block. Always use a new cylinder head gasket.

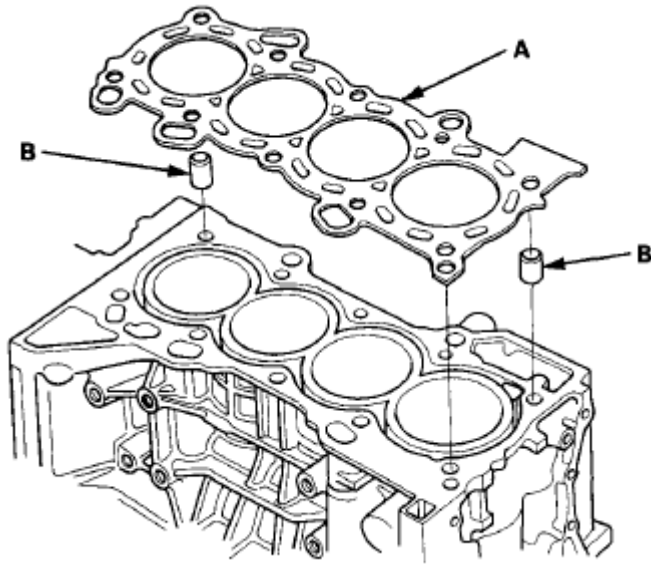

Fig. 136: Identifying Cylinder Head Gasket And Dowel Pins
 Courtesy of AMERICAN HONDA MOTOR CO., INC.

4. Set the crankshaft to top dead center (TDC). Align the TDC mark (A) on the crankshaft sprocket with the pointer (B) on the engine block.

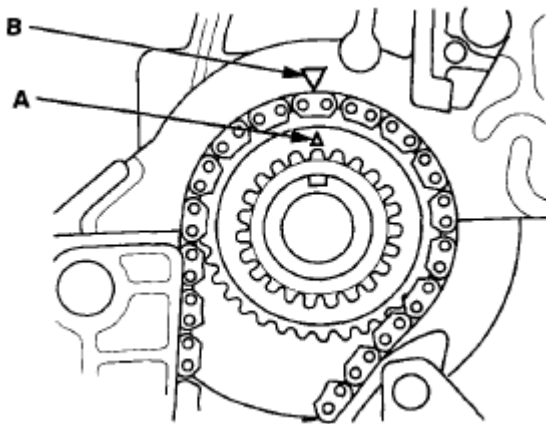

Fig. 137: Identifying Pointer On Engine Block
 Courtesy of AMERICAN HONDA MOTOR CO., INC.

5. Install the cylinder head on the block.
6. Measure the diameter of each cylinder head bolt at point A and point B.

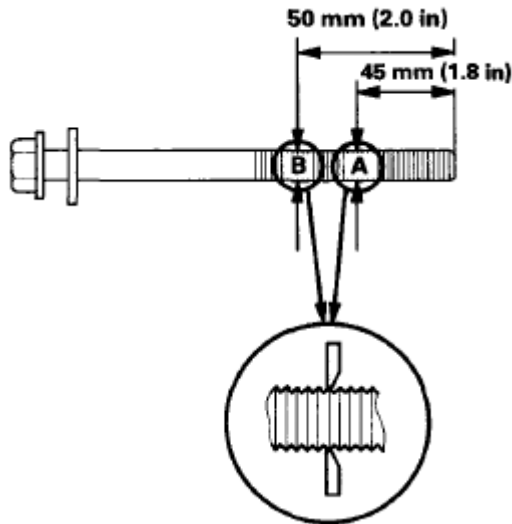

Fig. 138: Measuring Diameter Of Cylinder Head Bolt
Courtesy of AMERICAN HONDA MOTOR CO., INC.

7. If either diameter is less than 10.6 mm (0.42 in), replace the cylinder head bolt.
8. Apply engine oil to the threads and under the bolt heads of all cylinder head bolts.
9. Tighten the cylinder head bolts in sequence to 39 N.m (4.0 kgf.m, 29 lbf.ft). Use a beam-type torque wrench. When using a preset click-type torque wrench, be sure to tighten slowly and do not over tighten. If a bolt makes any noise while you are torquing it, loosen the bolt and retighten it from the first step.

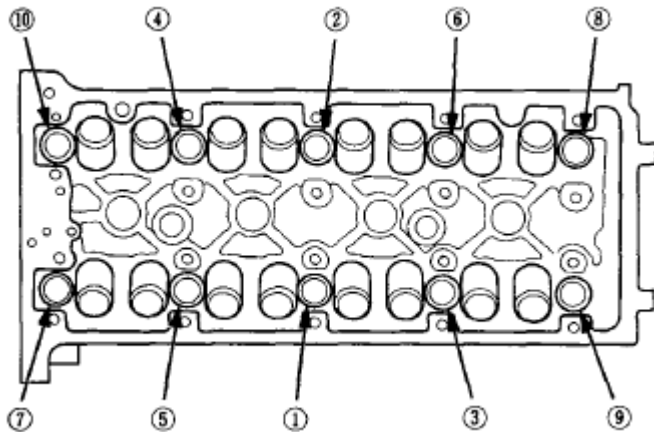

Fig. 139: Identifying Cylinder Head Bolts Tighten Sequence
Courtesy of AMERICAN HONDA MOTOR CO., INC.

10. After torquing, tighten all cylinder head bolts in two steps (90 ° per step). If you are using a new cylinder head bolt, tighten the bolt an extra 90 °.

NOTE: Remove the cylinder head bolt if you tightened it beyond the specified angle, and go back to step 6 of the procedure. Do not loosen it back to the specified angle.

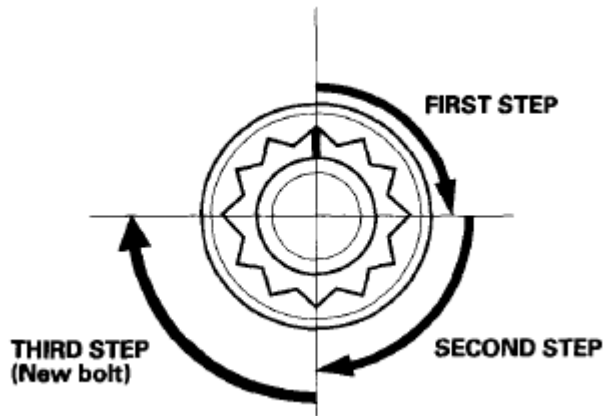

Fig. 140: Identifying Cylinder Head Bolt Tightening Torque
 Courtesy of AMERICAN HONDA MOTOR CO., INC.

11. Install the rocker arm assembly (see **ROCKER ARM ASSEMBLY INSTALLATION**).
12. Install the cam chain (see **CAM CHAIN INSTALLATION**).
13. Connect the following engine wire harness connectors, and install the wire harness clamps to the cylinder head:
 - Four fuel injector connectors
 - Engine coolant temperature (ECT) sensor 1 connector
 - Camshaft position (CMP) sensor A (Intake) connector
 - Camshaft position (CMP) sensor B (Exhaust) connector
 - Rocker arm oil control solenoid connector
 - Rocker arm oil pressure switch connector
 - EVAP canister purge valve connector
 - Exhaust gas recirculation (EGR) valve connector
14. Install the bolt (A) securing the connecting pipe.

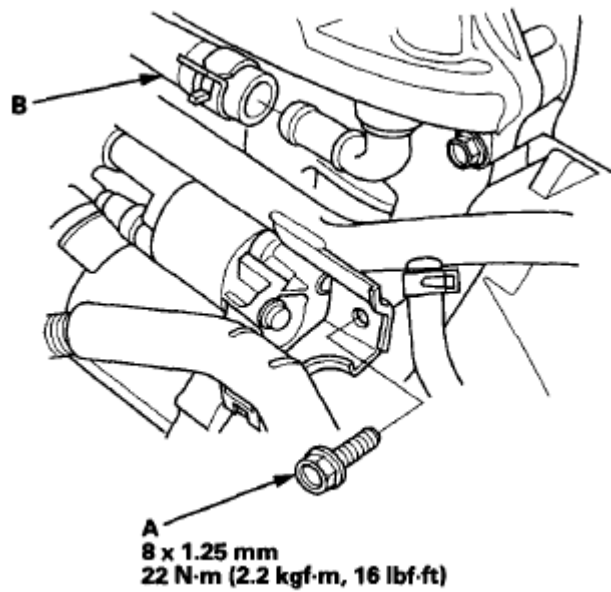

Fig. 141: Identifying Water Bypass Hose And Bolt With Torque Specifications
 Courtesy of AMERICAN HONDA MOTOR CO., INC.

15. Install the water bypass hose (B).
16. Install the upper radiator hose (A) and the heater hoses (B).

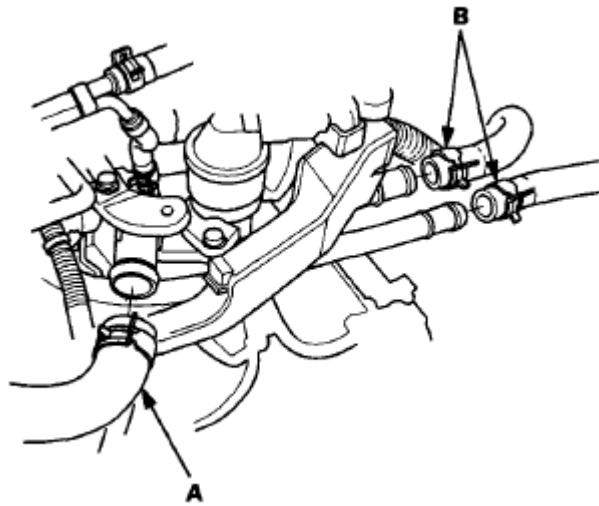

Fig. 142: Identifying Upper Radiator Hose And Heater Hoses
 Courtesy of AMERICAN HONDA MOTOR CO., INC.

17. Install the harness holder bracket (A), then install the harness holder (B).

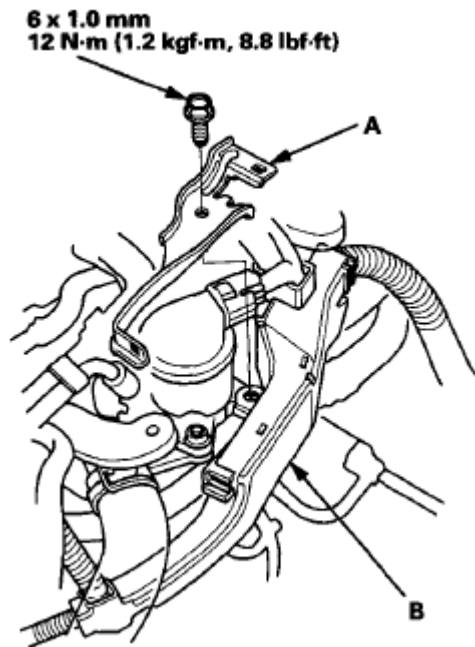

Fig. 143: Identifying Harness Holder Bracket And Harness Holder With Torque Specification
Courtesy of AMERICAN HONDA MOTOR CO., INC.

18. Install the positive crankcase ventilation (PCV) hose (A) and the ground cable (B).

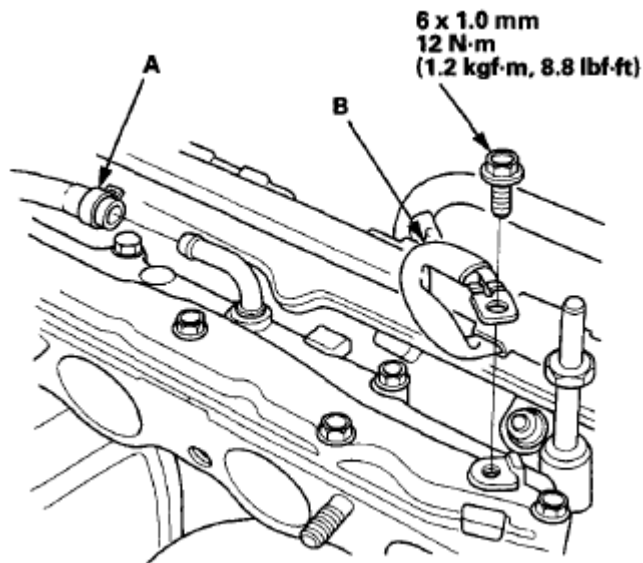

Fig. 144: Identifying Positive Crankcase Ventilation Hose And Ground Cable With Torque Specification
Courtesy of AMERICAN HONDA MOTOR CO., INC.

19. Connect the fuel feed hose (A) (see **FUEL LINE/QUICK-CONNECT FITTING INSTALLATION**), then install the quick-connect fitting cover (B).

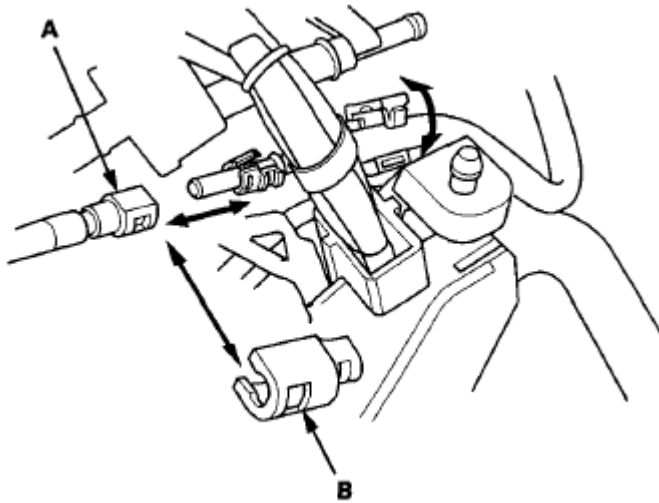

Fig. 145: Identifying Fuel Feed Hose And Quick-Connect Fitting Cover
Courtesy of AMERICAN HONDA MOTOR CO., INC.

20. Install the evaporative emission (EVAP) canister hose (A) and the brake booster vacuum hose (B).

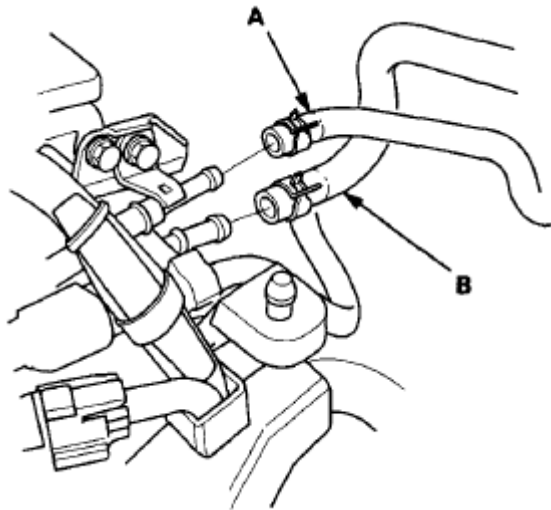

Fig. 146: Identifying Evaporative Emission Canister Hose And Brake Booster Vacuum Hose
Courtesy of AMERICAN HONDA MOTOR CO., INC.

21. Install the exhaust manifold (see **EXHAUST MANIFOLD REMOVAL AND INSTALLATION**).
22. Install the intake manifold (see **INSTALLATION**).
23. Install the drive belt (see **DRIVE BELT REMOVAL/INSTALLATION**).
24. Install the air cleaner housing (see **AIR CLEANER REMOVAL/INSTALLATION**).
25. After installation, check that all tubes, hoses and connectors are installed correctly.
26. Inspect for fuel leaks. Turn the ignition switch ON (II) (do not operate the starter) so the fuel pump runs for about 2 seconds and pressurizes the fuel line. Repeat this operation three times, then check for fuel leakage at any point in the fuel line.

27. Refill the radiator with engine coolant, and bleed the air from the cooling system (see COOLANT CHECK).
28. Do The PCM Idle Learn Procedure ECM/PCM IDLE LEARN PROCEDURE
29. Inspect the idle speed (see IDLE SPEED INSPECTION).
30. Inspect the ignition timing (see IGNITION TIMING INSPECTION).

SEALING BOLT INSTALLATION

NOTE: When installing the sealing bolt, always use a new washer.

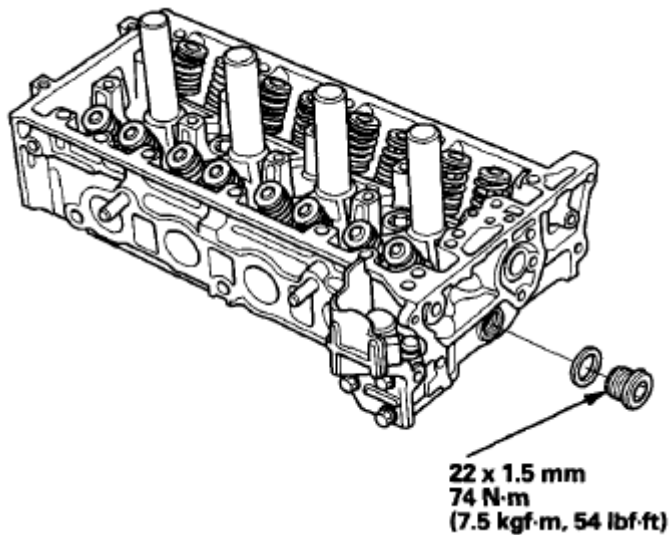

Fig. 147: Identifying Sealing Bolt With Torque Specification
Courtesy of AMERICAN HONDA MOTOR CO., INC.

2007-11 ENGINE

Engine Block (K24Z1) - CR-V

SPECIAL TOOLS

Ref.No.	Tool Number	Description	Qty
①	07749-0010000	Driver Handle, 15 x 135L	1
②	07ZAD-PNAA100	Oil Seal Driver Attachment, 96 mm	1

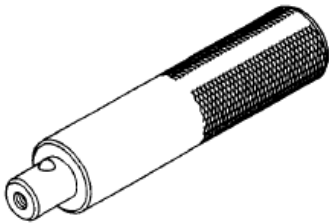

①

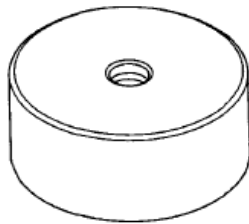

②

Fig. 1: Identifying Special Tools

Courtesy of AMERICAN HONDA MOTOR CO., INC.

COMPONENT LOCATION INDEX

2011 Honda CR-V EX

2007-11 ENGINE Engine Block (K24Z1) - CR-V

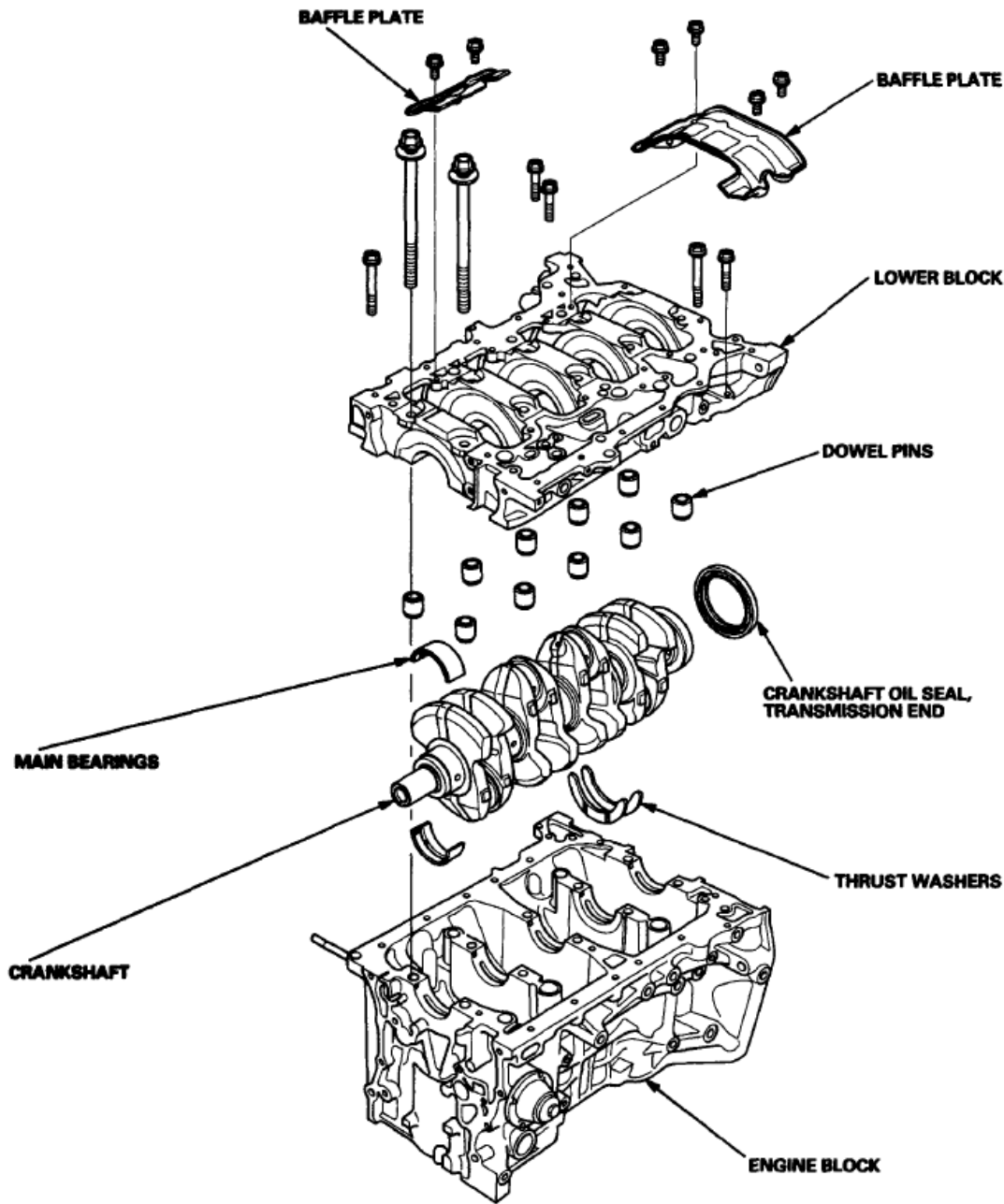

Fig. 2: Identifying Engine Block Component Location (1 Of 2)
Courtesy of AMERICAN HONDA MOTOR CO., INC.

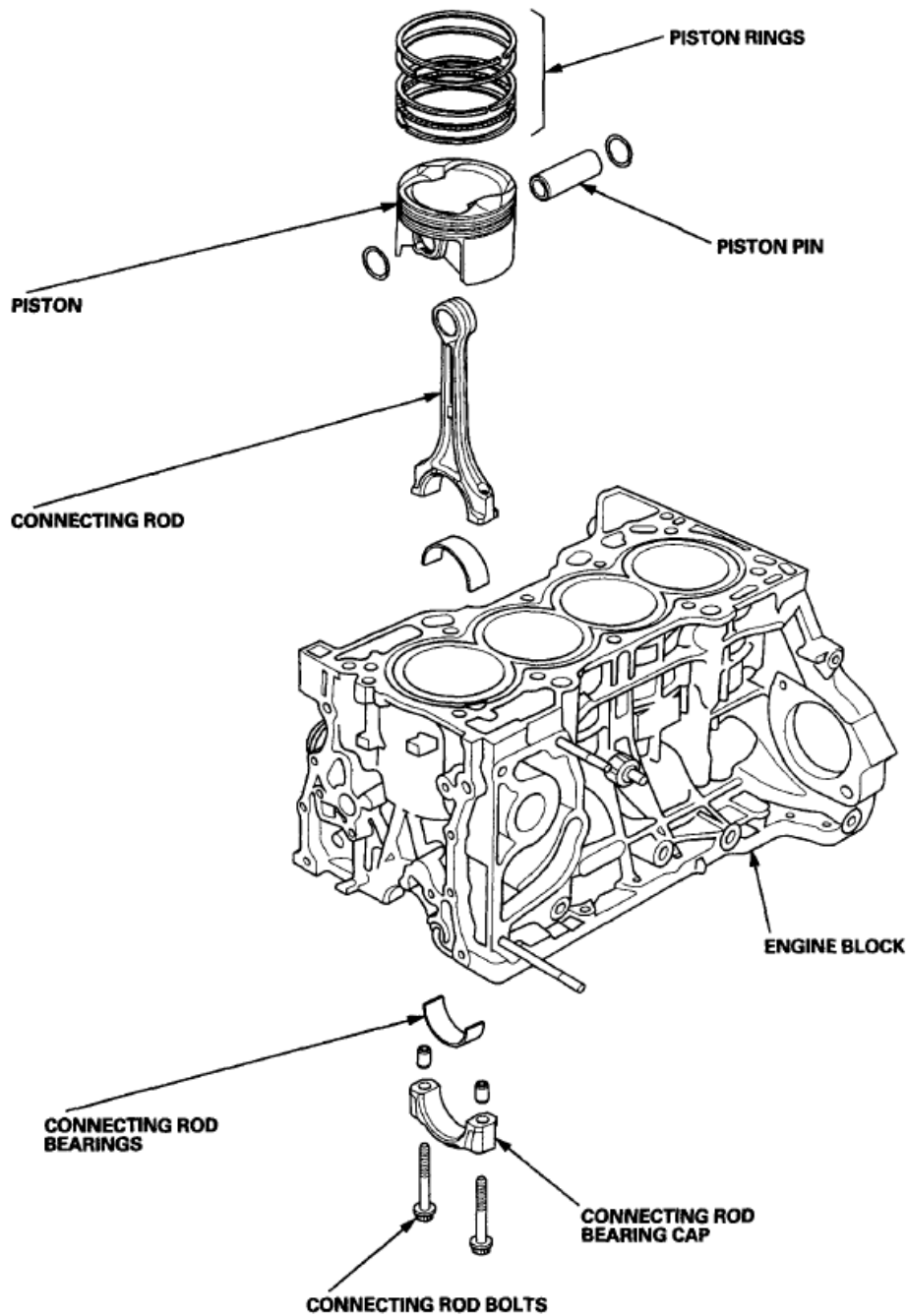

Fig. 3: Identifying Engine Block Component Location (2 Of 2)
 Courtesy of AMERICAN HONDA MOTOR CO., INC.

CONNECTING ROD AND CRANKSHAFT END PLAY INSPECTION

1. Remove the oil pump (see [OIL PUMP REMOVAL](#)).
2. Remove the baffle plates (see step 7).
3. Measure the connecting rod end play with a feeler gauge between the connecting rod and the crankshaft.

Connecting Rod End Play

Standard (New): 0.15-0.35 mm (0.006-0.014 in)

Service Limit: 0.40 mm (0.016 in)

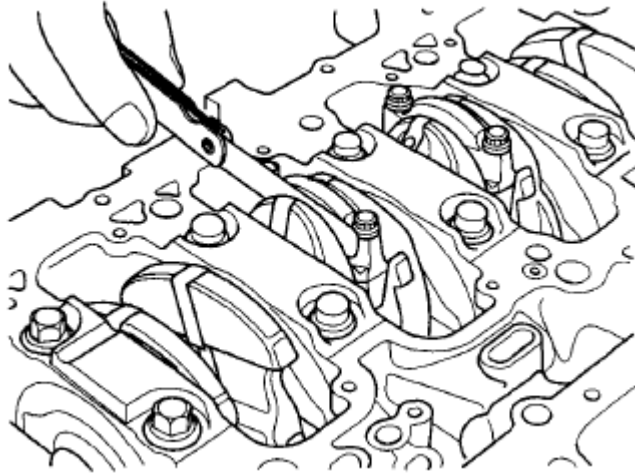

Fig. 4: Measuring Connecting Rod End Play With Feeler Gauge Between Connecting Rod And Crankshaft

Courtesy of AMERICAN HONDA MOTOR CO., INC.

4. If the connecting rod end play is beyond service limit, install a new connecting rod, and recheck. If it is still beyond service limit; replace the crankshaft (see **CRANKSHAFT AND PISTON REMOVAL**).
5. Push the crankshaft firmly away from the dial indicator, and zero the dial against the end of the crankshaft. Then pull the crankshaft firmly back toward the indicator; the dial reading should not exceed the service limit.

Crankshaft End Play

Standard (New): 0.10-0.35 mm (0.004-0.014 in)

Service Limit: 0.45 mm (0.018 in)

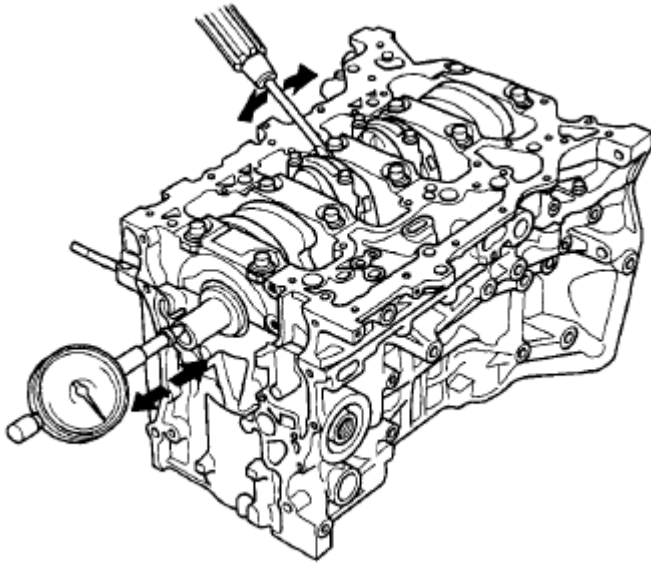

Fig. 5: Measuring Crankshaft End Play

Courtesy of AMERICAN HONDA MOTOR CO., INC.

6. If the end play is beyond service limit, replace the thrust washers and recheck, if it is still beyond service limit, replace the crankshaft (see CRANKSHAFT AND PISTON REMOVAL).

CRANKSHAFT MAIN BEARING REPLACEMENT

MAIN BEARING CLEARANCE INSPECTION

1. To check main bearing-to-journal oil clearance, remove the lower block and bearing halves (see CRANKSHAFT AND PISTON REMOVAL).
2. Clean each main journal and bearing half with a clean shop towel.
3. Place one strip of plastigage across each main journal.
4. Reinstall the bearings and lower block, then torque the bolts to 29 N.m (3.0 kgf.m, 22 lbf.ft).

NOTE:

- Apply new engine oil to the bolt threads and flanges.
- Do not rotate the crankshaft during inspection.

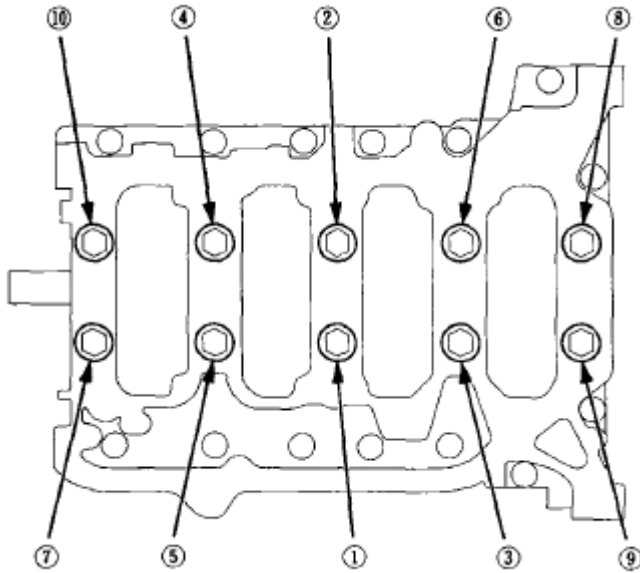

Fig. 6: Identifying Bearing Cap Bolts Tighten Sequence
 Courtesy of AMERICAN HONDA MOTOR CO., INC.

5. Tighten the bearing cap bolts an additional 56 °.
6. Remove the lower block and bearings again, and measure the widest part of the plastigage.

Main Bearing-to-Journal Oil Clearance

No. 1, 2, 4, 5 Journals:

Standard (New): 0.017-0.041 mm (0.0007-0.0016 in)

Service Limit: 0.050 mm (0.0020 in)

No. 3 Journal:

Standard (New): 0.025-0.049 mm (0.0010-0.0019 in)

Service Limit: 0.055 mm (0.0022 in)

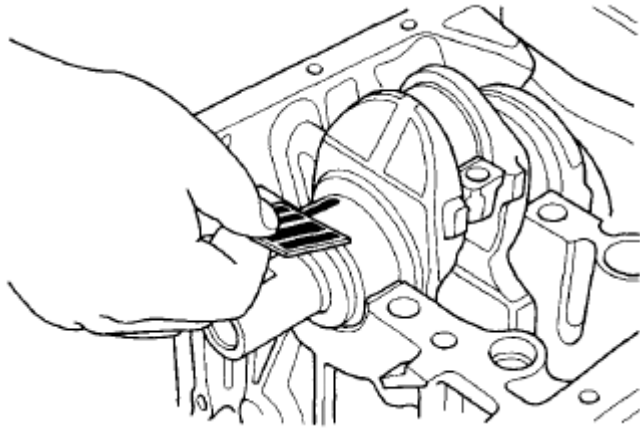

Fig. 7: Measuring Widest Part Of Plastigage
Courtesy of AMERICAN HONDA MOTOR CO., INC.

7. If the plastigage measures too wide or too narrow, remove the crankshaft, and remove the upper half of the bearing. Install a new, complete bearing with the appropriate color code(s), and recheck the clearance. Do not file, shim, or scrape the bearings or the caps to adjust clearance.
8. If the plastigage shows the clearance is still incorrect, try the next larger or smaller bearing (the color listed above or below the current one), and check again. If the proper clearance cannot be obtained by using the appropriate larger or smaller bearings, replace the crankshaft and start over.

MAIN BEARING SELECTION

Crankshaft Bore Code Location

1. Numbers, letters, or bars have been stamped on the end of the block as a code for the size of each of the five main journal bores. Write down the crank bore codes.

If you can't read the codes because of accumulated dirt and dust, do not scrub them with a wire brush or scraper. Clean them only with solvent or detergent.

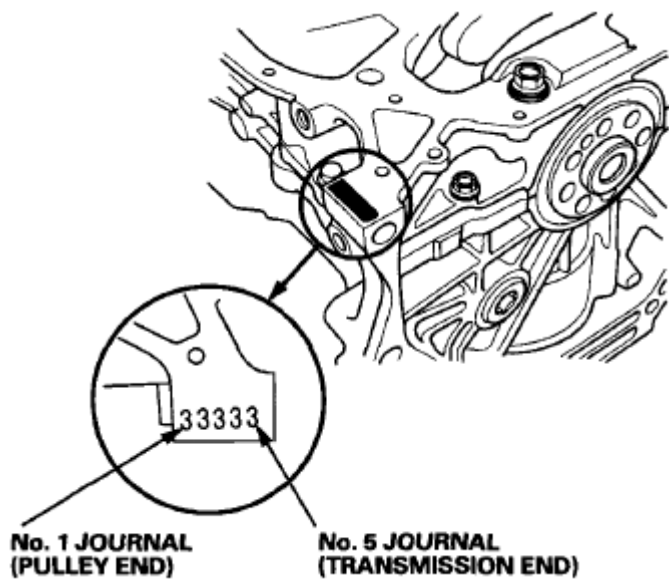

Fig. 8: Identifying Crankshaft Bore Code Location
Courtesy of AMERICAN HONDA MOTOR CO., INC.

Main Journal Code Location

2. The main journal codes are stamped on the crankshaft in either location.

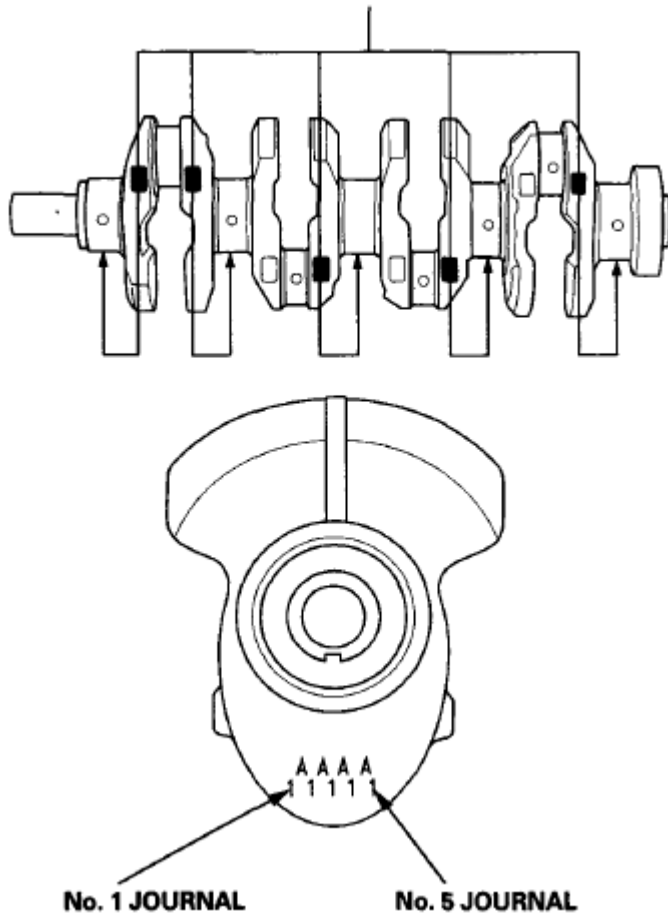

Fig. 9: Identifying Main Journal Code Location
 Courtesy of AMERICAN HONDA MOTOR CO., INC.

- Use the crank bore codes and crank journal codes to select the appropriate replacement bearings from the following table.

NOTE:

- The color code is on the edge of the bearing.
- When using bearing halves of different colors, it does not matter which color is used in the top or bottom.

Main journal code	Crank bore code	Larger crank bore			
		1 or A or I	2 or B or II	3 or C or III	4 or D or IIII
1		Pink	Pink/ Yellow	Yellow	Green
2		Pink/ Yellow	Yellow	Green	Green/ Brown
3		Yellow	Green	Green/ Brown	Brown
4		Green	Green/ Brown	Brown	Black
5		Green/ Brown	Brown	Black	Black/ Blue
6		Brown	Black	Black/ Blue	Blue

Smaller main journal Smaller bearing (Thicker)

Fig. 10: Color Code Chart

Courtesy of AMERICAN HONDA MOTOR CO., INC.

CONNECTING ROD BEARING REPLACEMENT

Rod Bearing Clearance Inspection

1. Remove the oil pump (see [OIL PUMP REMOVAL](#)).
2. Remove the baffle plates (see 7).
3. Remove the connecting rod cap and bearing half.
4. Clean the crankshaft rod journal and bearing half with a clean shop towel.
5. Place plastigage across the rod journal.
6. Reinstall the bearing half and cap, and torque the bolts to 20 N.m (2.0 kgf.m, 14 lbf.ft) + 90 °

NOTE:

- Apply new engine oil to the bolt threads and flanges.
- Do not rotate the crankshaft during inspection.

7. Remove the rod cap and bearing half, and measure the widest part of the plastigage.

Connecting Rod Bearing-to-Journal Oil

Clearance

Standard (New): 0.020-0.050 mm (0.0008-0.0020 in)

Service Limit: 0.060 mm (0.0024 in)

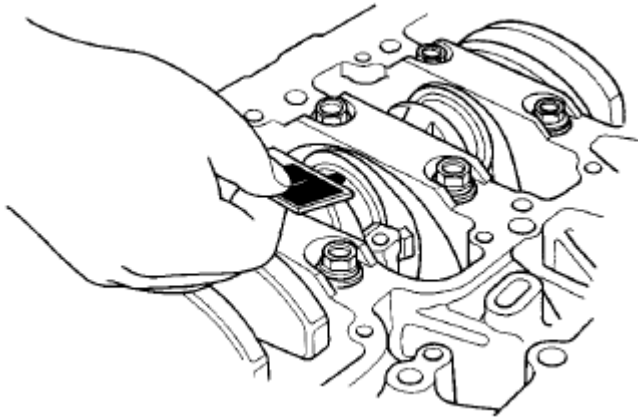

Fig. 11: Measuring Widest Part Of Plastigage
Courtesy of AMERICAN HONDA MOTOR CO., INC.

8. If the plastigage measures too wide or too narrow, remove the upper half of the bearing, install a new, complete bearing with the appropriate color code(s), and recheck the clearance. Do not file, shim, or scrape the bearings or the caps to adjust clearance.
9. If the plastigage shows the clearance is still incorrect, try the next larger or smaller bearing (the color listed above or below the current one), and check clearance again. If the proper clearance cannot be obtained by using the appropriate larger or smaller bearing, replace the crankshaft and start over.

ROD BEARING SELECTION

1. Inspect each connecting rod for cracks and heat damage.

Connecting Rod Big End Bore Code Locations

2. Each rod has a tolerance range from 0 to 0.024 mm (0.0009 in), in 0.006 mm (0.0002 in) increments, depending on the size of its big end bore. It's then stamped with a number or bar (1, 2, 3, or 4/I, II, III, or IIII) indicating the range. You may find any combination of numbers and bars in any engine. (Half the number or bar is stamped on the bearing cap, the other half is on the rod.)

If you can't read the code because of an accumulation of oil and varnish, do not scrub it with a wire brush or scraper. Clean it only with solvent or detergent.

Normal Bore Size: 51.0 mm (2.01 in)

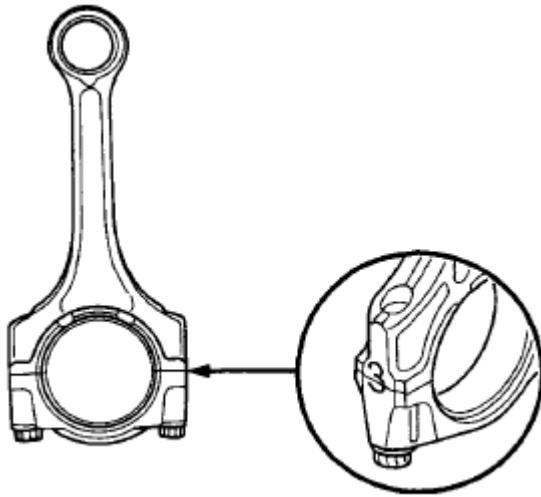

Fig. 12: Identifying Connecting Rod Big End Bore Code Locations
Courtesy of AMERICAN HONDA MOTOR CO., INC.

Connecting Rod Journal Code Location

3. The connecting rod journal codes are stamped on the crankshaft in either location.

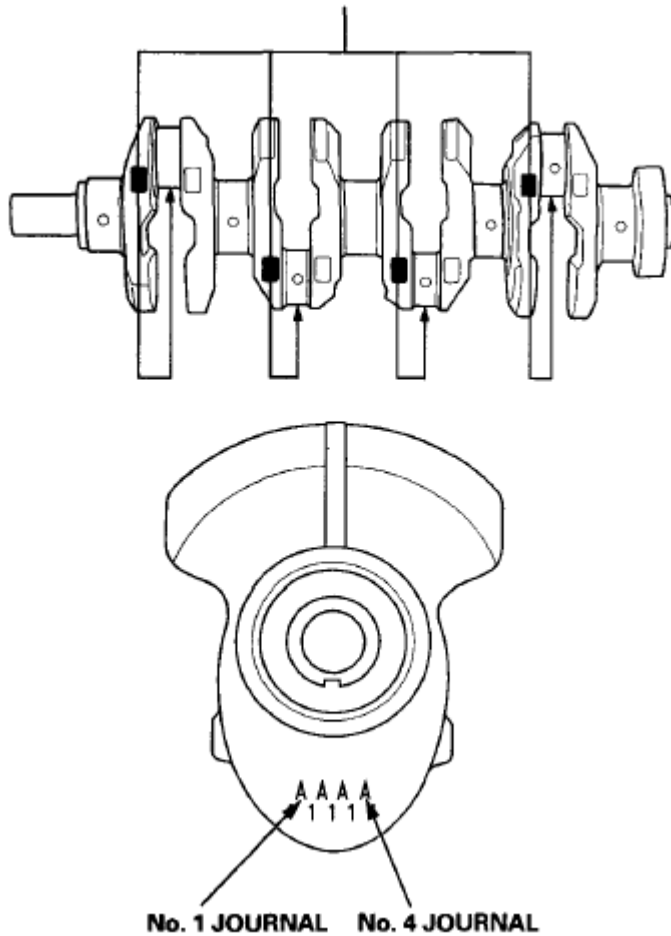

Fig. 13: Identifying Connecting Rod Journal Code Location
 Courtesy of AMERICAN HONDA MOTOR CO., INC.

- Use the big end bore codes and rod journal codes to select appropriate replacement bearings from the following table.

NOTE:

- The color code is on the edge of the bearing.
- When using bearing halves of different colors, it does not matter which color is used in the top or bottom.

		Big end bore code → Larger big end bore			
		1 or I	2 or II	3 or III	4 or IIII
		→ Smaller bearing (Thicker)			
Rod journal code	A	Pink	Pink/ Yellow	Yellow/ Green	Green
	B	Yellow	Yellow/ Green	Green/ Brown	Brown
	C	Green	Green/ Brown	Brown/ Black	Black
	D	Brown	Brown/ Black	Black/ Blue	Blue
	Smaller rod journal		Smaller bearing (Thicker)		

Fig. 14: Color Code Chart

Courtesy of AMERICAN HONDA MOTOR CO., INC.

OIL PAN REMOVAL

1. If the engine is already out of the vehicle, go to step 21.
2. Raise the vehicle on the lift.
3. Drain the engine oil (see **ENGINE OIL REPLACEMENT**).
4. Remove the front wheels.
5. Remove the splash shield (see step 20 under **ENGINE REMOVAL**).
6. Disconnect the air fuel ratio (A/F) sensor connector and secondary heated oxygen sensor (secondary HO2S) connector, then remove the three way catalytic converter (TWC) (see step 24 under **ENGINE REMOVAL**).
7. Remove the shift cable (see step 39 under **TRANSMISSION REMOVAL**).
8. Separate the stabilizer links from the stabilizer bar (see **STABILIZER LINK REMOVAL/INSTALLATION**).
9. Separate the knuckles from the lower arms (see **BALL JOINT REMOVAL**).
10. 4WD model: Remove the propeller shaft (see **PROPELLER SHAFT RUNOUT**).
11. Remove a bolt securing the P/S fluid line bracket, and unclamp the P/S fluid line clamps on the front subframe (see step 30 under **ENGINE REMOVAL**).
12. Remove the bolts securing the left steering gearbox mounting bracket (see step 31 under **ENGINE REMOVAL**).
13. Remove the bolts securing the right steering gearbox mounting brackets (see step 32 under **ENGINE REMOVAL**).
14. Remove the bolt securing the automatic transmission fluid (ATF) filter.

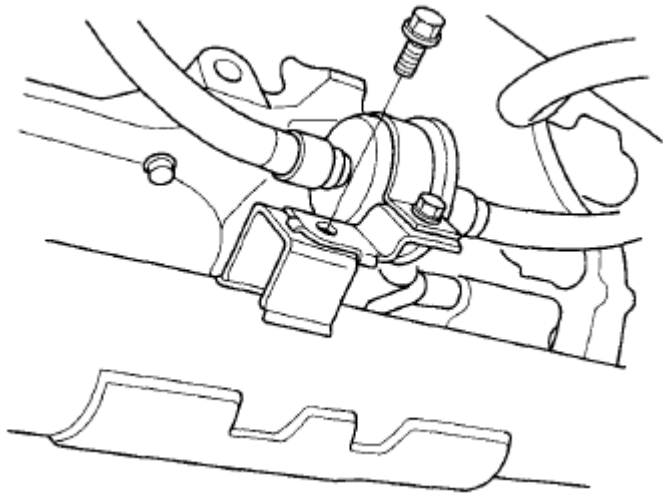

Fig. 15: Identifying Automatic Transmission Fluid Filter

Courtesy of AMERICAN HONDA MOTOR CO., INC.

15. Remove the lower torque rod (see step 44 under **ENGINE REMOVAL**).
16. Make the appropriate reference lines at both ends of the subframe that line up with the body (see step 45 under **ENGINE REMOVAL**).
17. Remove the subframe mounting bolts on both side (see step 46 under **ENGINE REMOVAL**).
18. Attach the subframe adapter to the subframe and hang the belt of the subframe adapter over the front of the subframe, then secure the belt with its stop (see step 47 under **ENGINE REMOVAL**).
19. Raise the jack and line up the slots in the arms with the bolt holes on the corner of the jack base, then attach them with bolts securely (see step 48 under **ENGINE REMOVAL**).
20. Remove the subframe (see step 50 under **ENGINE REMOVAL**).
21. Remove the lower torque rod bracket.

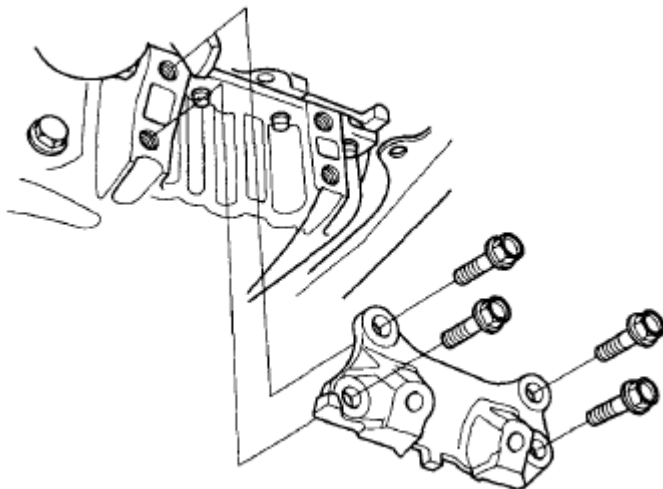

Fig. 16: Identifying Lower Torque Rod Bracket

Courtesy of AMERICAN HONDA MOTOR CO., INC.

22. Remove the torque converter cover.

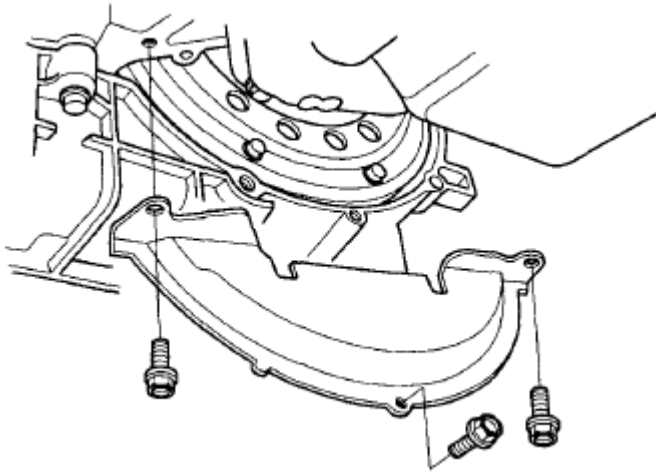

Fig. 17: Identifying Torque Converter Cover
 Courtesy of AMERICAN HONDA MOTOR CO., INC.

23. Remove the bolts securing the oil pan.
24. Using a flat blade screwdriver, separate the oil pan from the block in the places shown.

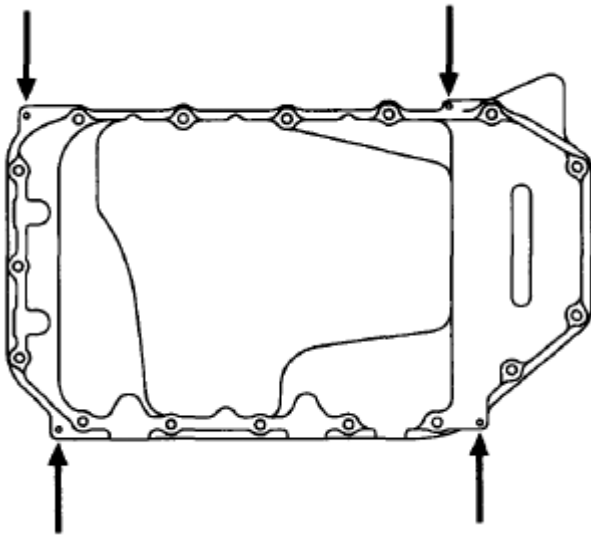

Fig. 18: Identifying Oil Pan Sealant Area
 Courtesy of AMERICAN HONDA MOTOR CO., INC.

25. Remove the oil pan.

CRANKSHAFT AND PISTON REMOVAL

1. Remove the engine assembly (see ENGINE REMOVAL).

2. Remove the transmission (see **TRANSMISSION REMOVAL**).
3. Remove the drive plate (see **DRIVE PLATE REMOVAL AND INSTALLATION**).
4. Remove the oil pan (see **OIL PAN REMOVAL**).
5. Remove the oil pump (see **OIL PUMP REMOVAL**).
6. Remove the cylinder head (see **CYLINDER HEAD REMOVAL**).
7. Remove the baffle plates.

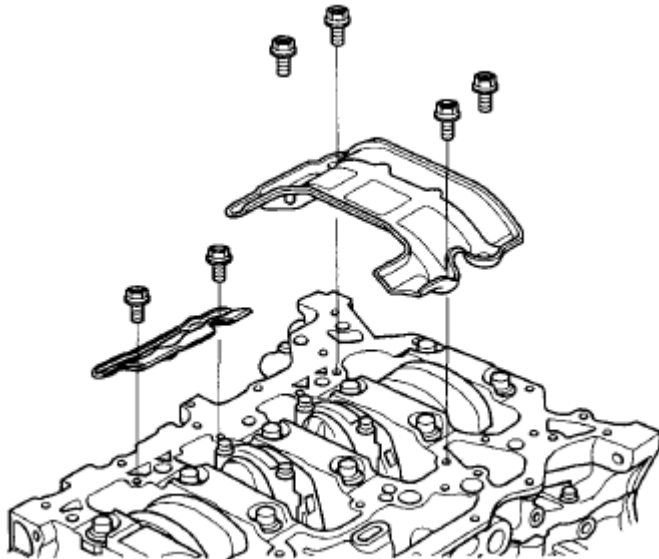

Fig. 19: Identifying Baffle Plates

Courtesy of AMERICAN HONDA MOTOR CO., INC.

8. Remove the 8 mm bolts

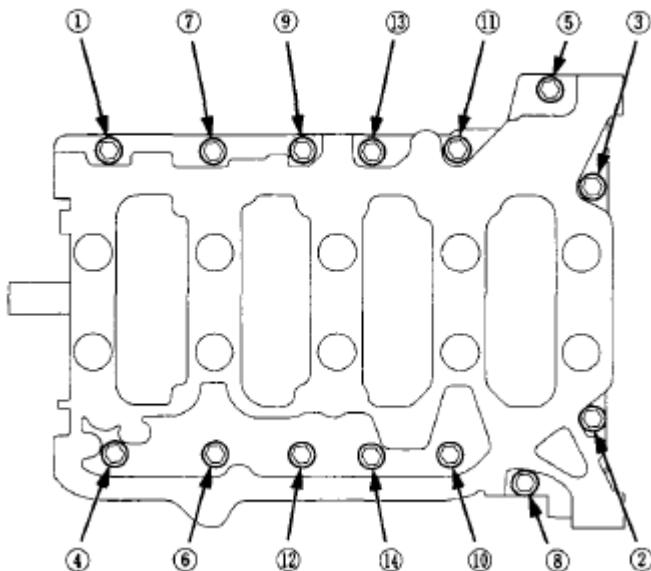
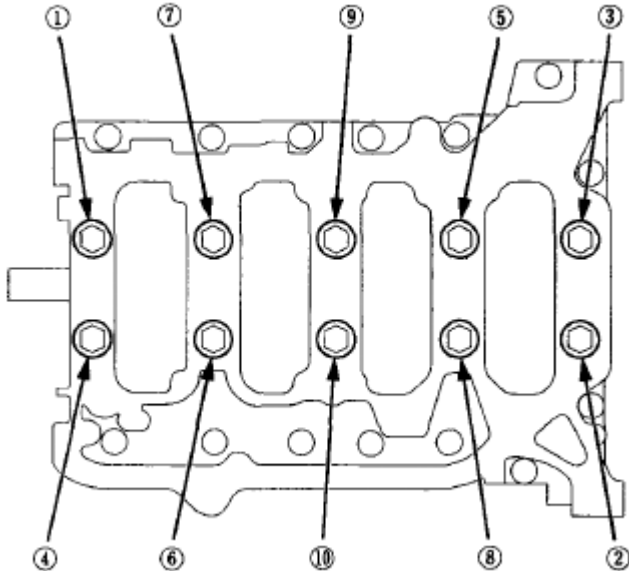

Fig. 20: Identifying Baffle Plates Bolts

Courtesy of AMERICAN HONDA MOTOR CO., INC.

9. Remove the bearing cap bolts. To prevent warpage, unscrew the bolts in sequence 1/3 turn at a time; repeat the sequence until all bolts are loosened.

**Fig. 21: Identifying Bearing Cap Bolts Remove Sequence**

Courtesy of AMERICAN HONDA MOTOR CO., INC.

10. Remove the lower block and bearings. Keep all the bearings in order.

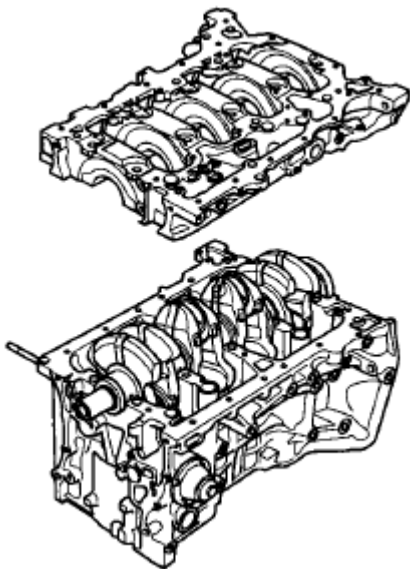
**Fig. 22: Identifying Lower Block And Bearings**

Courtesy of AMERICAN HONDA MOTOR CO., INC.

11. Remove the rod caps/bearings. Keep all caps/bearings in order.
12. Lift the crankshaft out of the engine. Be careful not to damage the journals.

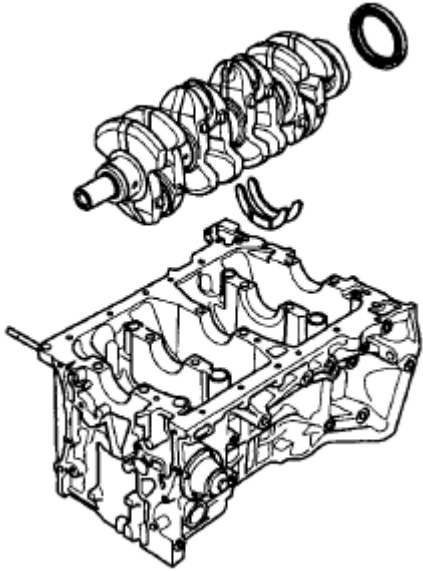

Fig. 23: Identifying Upper Bearing Halves And Connecting Rods
Courtesy of AMERICAN HONDA MOTOR CO., INC.

13. Remove the upper bearing halves from the connecting rods, and set them aside with their respective caps.
14. If you can feel a ridge of metal or hard carbon around the top of each cylinder, remove it with a ridge reamer (A). Follow the reamer manufacturer's instructions. If the ridge is not removed, it may damage the pistons as they are pushed out.

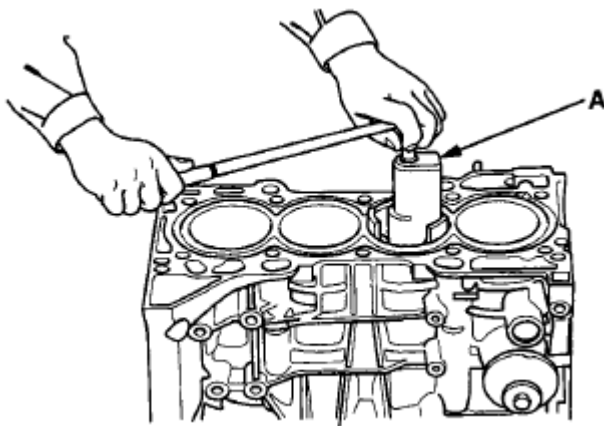

Fig. 24: Removing Upper Bearing Halves From Connecting Rods
Courtesy of AMERICAN HONDA MOTOR CO., INC.

15. Use the wooden handle of a hammer (A) to drive out the piston/connecting rod assembly (B).

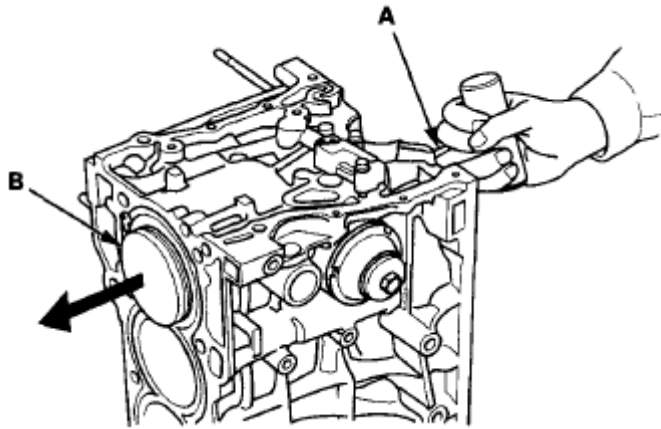

Fig. 25: Identifying Piston And Connecting Rod Assembly
 Courtesy of AMERICAN HONDA MOTOR CO., INC.

16. Reinstall the lower block and the bearings on the engine in the proper order.
17. Reinstall the connecting rod bearings and caps after removing each piston/connecting rod assembly.
18. Mark each piston/connecting rod assembly with its cylinder number to make sure they are reused in the original order.

NOTE: The existing number on the connecting rod does not indicate its position in the engine, it indicates the rod bore size.

CRANKSHAFT INSPECTION

Out-of-Round and Taper

1. Remove the crankshaft from the engine block (see CRANKSHAFT AND PISTON REMOVAL).
2. Clean the crankshaft oil passages with pipe cleaners or a suitable brush.
3. Clean the keyway and threads.
4. Measure the out-of-round at the middle of each rod and main journal in two places. The difference between measurements on each journal must not be more than the service limit.

Journal Out-of-Round

Standard (New): 0.005 mm (0.0002 in) max.

Service Limit: 0.010 mm (0.0004 in)

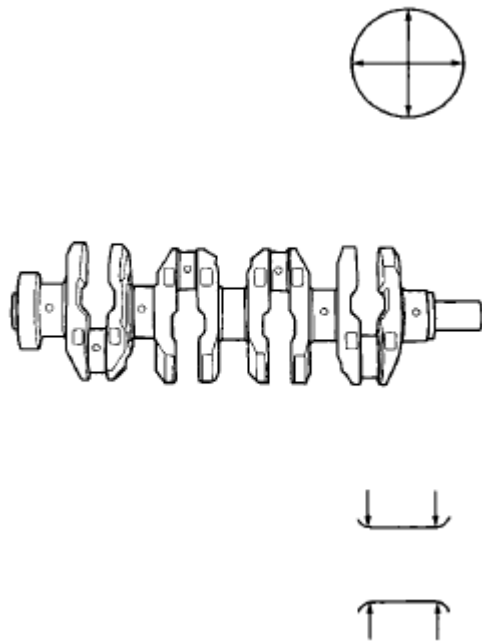

Fig. 26: Inspecting Crankshaft

Courtesy of AMERICAN HONDA MOTOR CO., INC.

5. Measure the taper at the edges of each rod and main journal. The difference between measurements on each journal must not be more than the service limit.

Journal Taper

Standard (New): 0.005 mm (0.0002 in) max.

Service Limit: 0.010 mm (0.0004 in)

Straightness

6. Place the engine block on the surface plate.
7. Clean and install the bearings on the No. 1 and No. 5 journals of the engine block.
8. Lower the crankshaft into the block.
9. Measure runout on all main journals. Rotate the crankshaft two complete revolutions. The difference between measurements on each journal must not be more than the service limit.

Crankshaft Total Runout

Standard (New): 0.03 mm (0.0012 in) max.

Service Limit: 0.04 mm (0.0016 in)

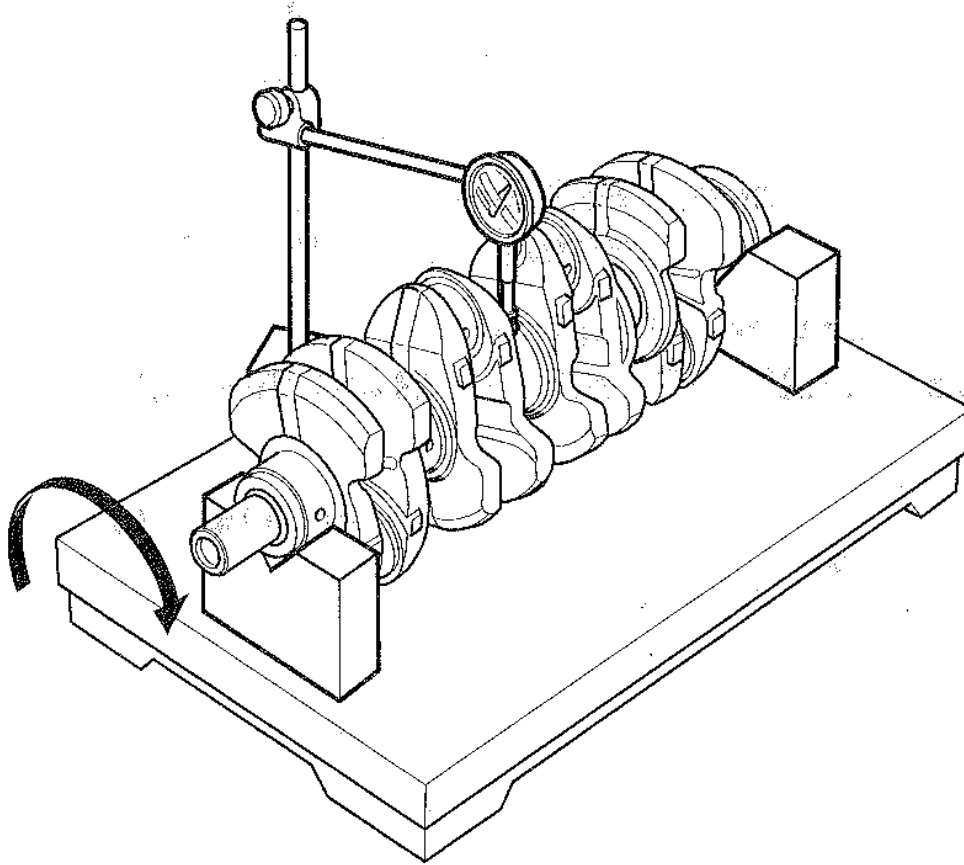

Fig. 27: Measuring Runout On Main Journals
Courtesy of AMERICAN HONDA MOTOR CO., INC.

BLOCK AND PISTON INSPECTION

1. Remove the crankshaft and pistons (see **CRANKSHAFT AND PISTON REMOVAL**).
2. Check the piston for distortion or cracks.
3. Measure the piston diameter at a point 13 mm (0.5 in) from the bottom of the skirt. There are two standard-size pistons (No Letter or A, and B). The letter is stamped on the top of the piston. Letters are also stamped on the block as cylinder bore sizes.

Piston Diameter

Standard (New):

No Letter (or A): 86.980-86.990 mm (3.4244-3.4248 in)

B: 86.970-86.980 mm (3.4240-3.4244 in)

Service Limit:

No Letter (or A): 86.930 mm (3.4224 in)

B: 86.920 mm (3.4220 in)

Oversize Piston Diameter

0.25: 87.230-87.240 mm (3.4342-3.4346 in)

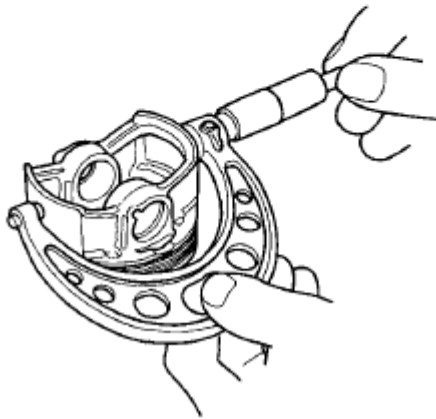
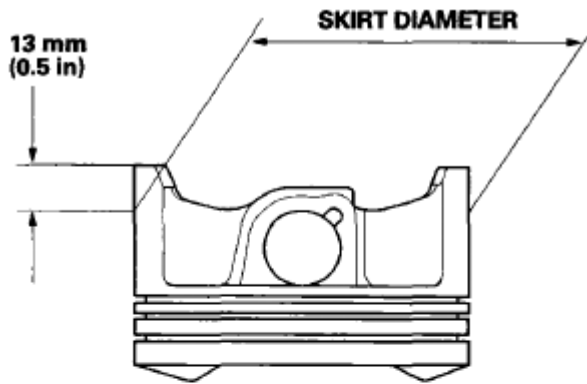

Fig. 28: Measuring Piston Diameter From Bottom Of Skirt
 Courtesy of AMERICAN HONDA MOTOR CO., INC.

4. Measure the wear and taper in direction X and Y at three levels inside each cylinder as shown. If the measurements in any cylinder are beyond the Oversize Bore Service Limit, replace the block. If the block is being rebored, refer to step 7 after reboring.

Cylinder Bore Size

Standard (New):

A or I: 87.010-87.020 mm (3.4256-3.4260 in)

B or II: 87.000-87.010 mm (3.4252-3.4256 in)

Service Limit: 87.070 mm (3.4279 in)

Oversize Bore

0.25: 87.250-87.260 mm (3.4350-3.4354 in)

Reboring Limit: 0.25 mm (0.010 in) max.

Bore Taper

Limit: (Difference between first and third measurement) 0.05 mm (0.002 in)

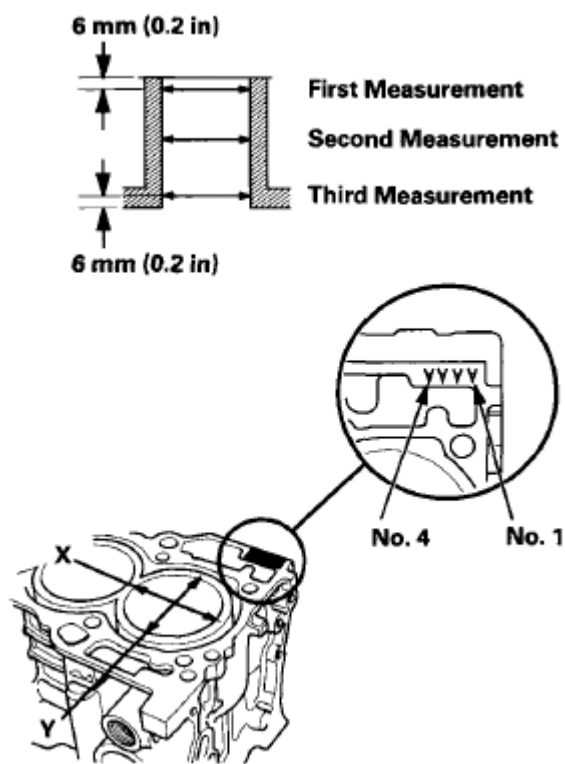

Fig. 29: Identifying Cylinder Bore Size Dimension
 Courtesy of AMERICAN HONDA MOTOR CO., INC.

5. Scored or scratched cylinder bores must be honed.
6. Check the top of the block for warpage. Measure along the edges, and across the center as shown.

Engine Block Warpage

Standard (New): 0.07 mm (0.003 in) max.

Service Limit: 0.10 mm (0.004 in)

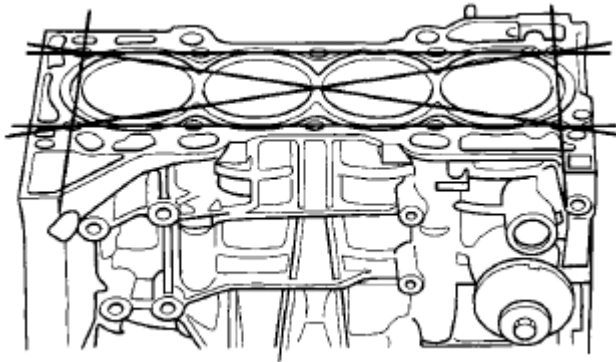

Fig. 30: Precaution For Engine Block Warpage
Courtesy of AMERICAN HONDA MOTOR CO., INC.

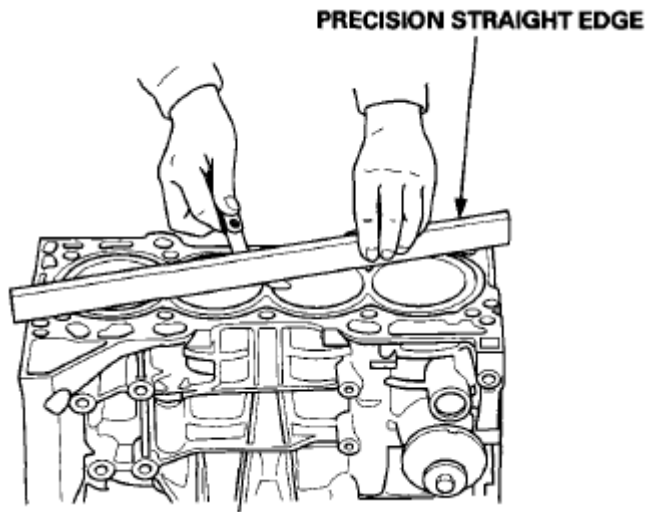

Fig. 31: Checking Engine Block Warpage
Courtesy of AMERICAN HONDA MOTOR CO., INC.

7. Calculate the difference between the cylinder bore diameter and the piston diameter. If the clearance is near or exceeds the service limit, inspect the piston and cylinder bore for excessive wear.

Piston-to-Cylinder Bore Clearance

Standard (New): 0.020-0.040 mm (0.0008-0.0016 in)

Service Limit: 0.05 mm (0.002 in)

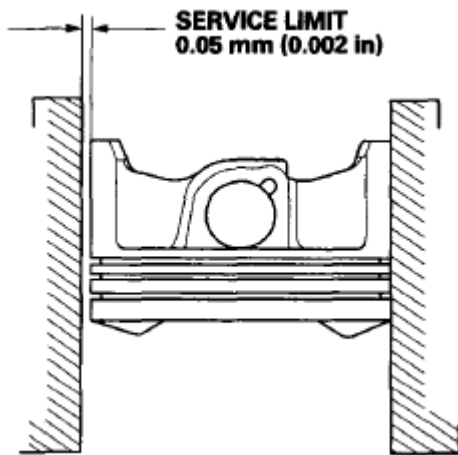

Fig. 32: Identifying Piston-To-Cylinder Bore Clearance
Courtesy of AMERICAN HONDA MOTOR CO., INC.

CYLINDER BORE HONING

Only a scored or scratched cylinder bore must be honed.

1. Measure the cylinder bores (see **BLOCK AND PISTON INSPECTION**).

If the block is to be reused, hone the cylinders, and remeasure the bores.

2. Hone the cylinder bores with honing oil and a fine (400 grit) stone in a 60 degree cross-hatch pattern (A). Use only a rigid hone with 400 grit or finer stone such as Sunnen, Ammco, or equivalent. Do not use stones that are worn or broken.

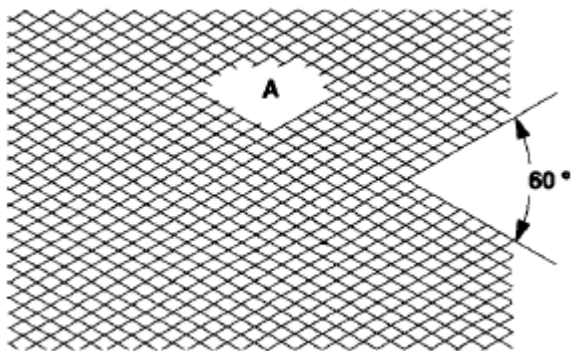

Fig. 33: [Identifying Cylinder Bores Cross-Hatch Pattern]
Courtesy of AMERICAN HONDA MOTOR CO., INC.

3. When honing is complete, thoroughly clean the engine block of all metal particles. Wash the cylinder bores with hot soapy water, then dry and oil them immediately to prevent rusting. Never use solvent, it will only redistribute the grit on the cylinder walls.

NOTE: Never use solvent, it will only redistribute the grit on the cylinder walls.

4. If scoring or scratches are still present in the cylinder bores after honing the engine block to the service limit, rebore the engine block. Some light vertical scoring and scratching is acceptable if it is not deep enough to catch your fingernail, and does not run the full length of the bore.

PISTON, PIN, AND CONNECTING ROD REPLACEMENT

DISASSEMBLY

1. Remove the piston from the engine block (see CRANKSHAFT AND PISTON REMOVAL).
2. Apply new engine oil to the piston pin snap rings (A), and turn them in the ring grooves until the end gaps are lined up with the cutouts in the piston pin bores (B).

NOTE: Take care not to damage the ring grooves.

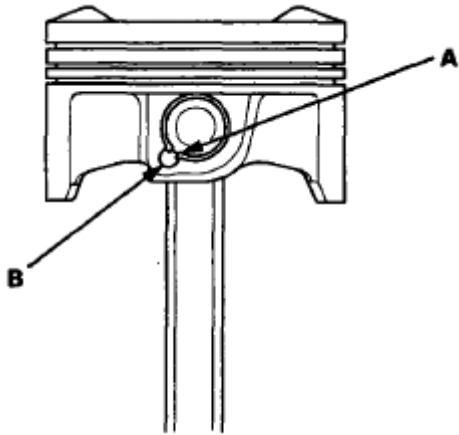

Fig. 34: Identifying Piston Pin Snap Rings And Piston Pin Bores
Courtesy of AMERICAN HONDA MOTOR CO., INC.

3. Remove both snap rings. Start at the cutout in the piston pin bore. Remove the snap rings carefully so they do not go flying or get lost. Wear eye protection.

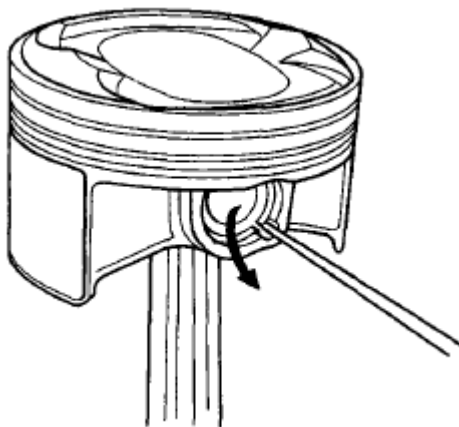
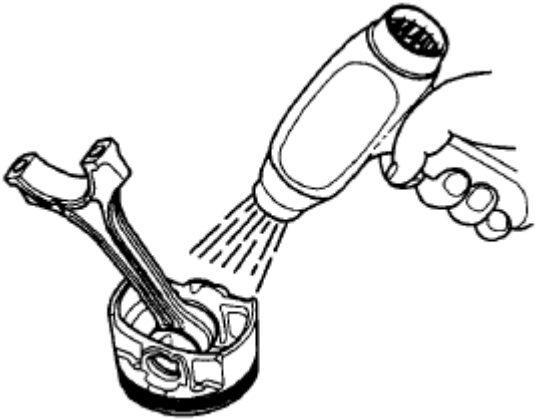

Fig. 35: Removing Snap Rings

Courtesy of AMERICAN HONDA MOTOR CO., INC.

4. Heat the piston and connecting rod assembly to about 158 °F (70 °C), then remove the piston pin.

**Fig. 36: Heating Piston And Connecting Rod Assembly**

Courtesy of AMERICAN HONDA MOTOR CO., INC.

INSPECTION

NOTE: Inspect the piston, the piston pin, and the connecting rod when they are at room temperature.

1. Measure the diameter of the piston pin.

Piston Pin Diameter**Standard (New): 21.961-21.965 mm (0.8646-0.8648 in)****Service Limit: 21.953 mm (0.8643 in)**

Fig. 37: Measuring Diameter Of Piston Pin

Courtesy of AMERICAN HONDA MOTOR CO., INC.

2. Zero the dial indicator to the piston pin diameter.

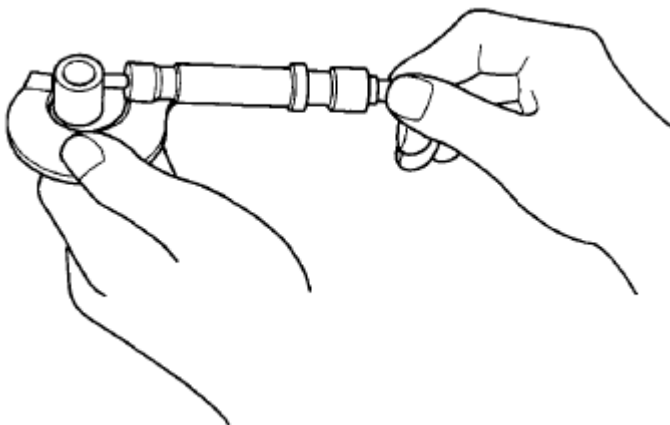
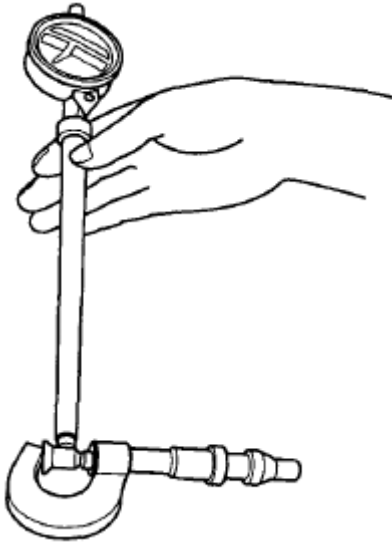

Fig. 38: Measuring Piston Pin Diameter Using Dial Indicator

Courtesy of AMERICAN HONDA MOTOR CO., INC.

3. Check the difference between the piston pin diameter and the piston pin hole diameter in the piston.

Piston Pin-to-Piston Clearance

Standard (New): -0.005-0.002 mm (-0.0002-0.0001 in)

Service Limit: 0.005 mm (0.0002 in)

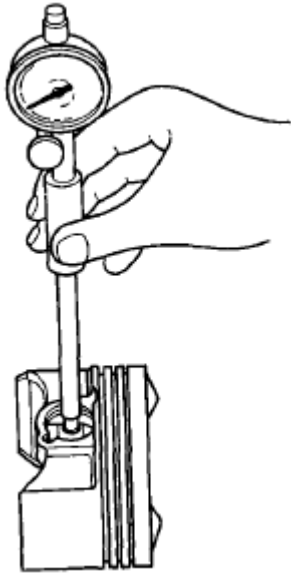

Fig. 39: Checking Difference Between Piston Pin Diameter And Piston Pin Hole Diameter
Courtesy of AMERICAN HONDA MOTOR CO., INC.

4. Measure the piston pin-to-connecting rod clearance.

Piston Pin-to-Connecting Rod Clearance

Standard (New): 0.005-0.015 mm (0.0002-0.0006 in)

Service Limit: 0.02 mm (0.001 in)

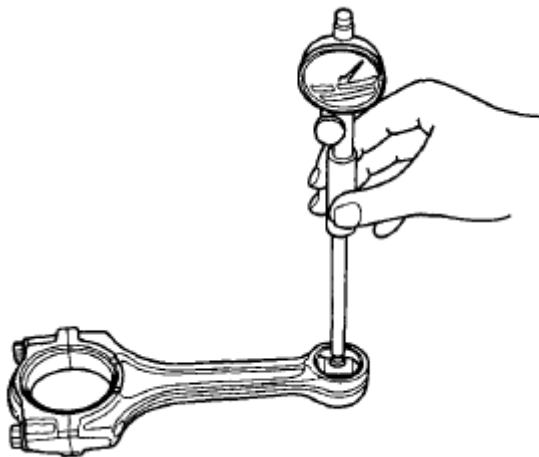

Fig. 40: Measuring Piston Pin-To-Connecting Rod Clearance
Courtesy of AMERICAN HONDA MOTOR CO., INC.

REASSEMBLY

1. Install a piston pin snap ring (A).

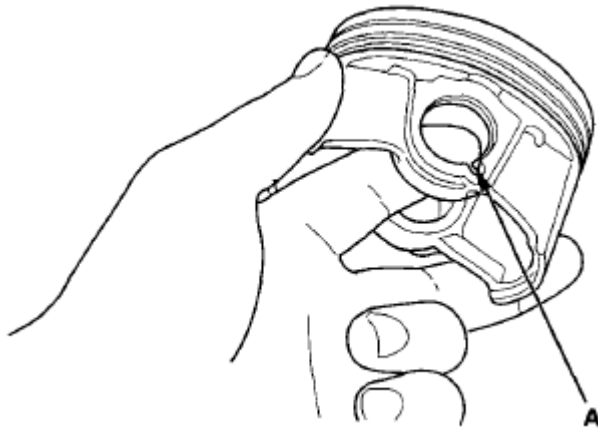

Fig. 41: Installing Piston Pin Snap Ring

Courtesy of AMERICAN HONDA MOTOR CO., INC.

2. Coat the piston pin bore in the piston, the bore in the connecting rod, and the piston pin with new engine oil.
3. Heat the piston to about 158 °F (70 °C).

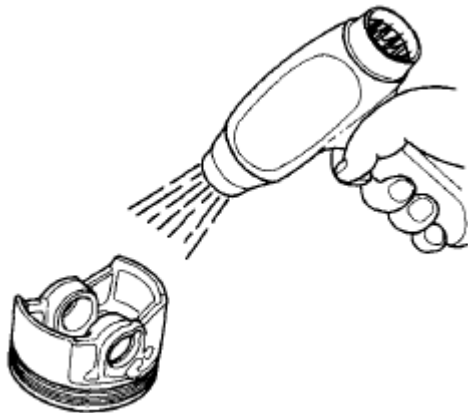

Fig. 42: Heating Piston

Courtesy of AMERICAN HONDA MOTOR CO., INC.

4. Assemble the piston (A) and the connecting rod (B) with the arrow (C) and the embossed mark (D) on the same side. Install the piston pin (E).

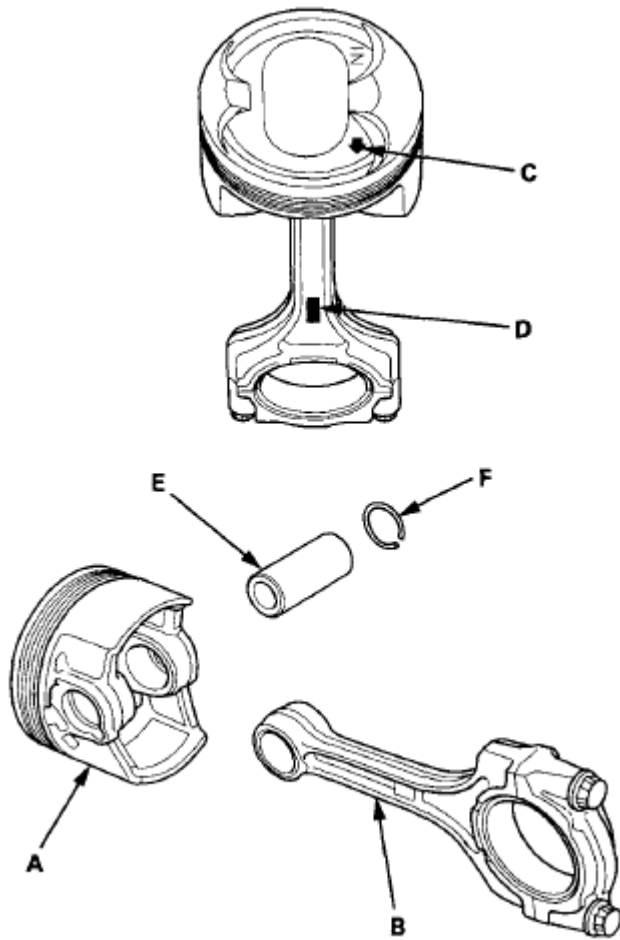

Fig. 43: Identifying Piston And Connecting Rod
 Courtesy of AMERICAN HONDA MOTOR CO., INC.

5. Install the remaining snap ring (F).
6. Turn the snap rings in the ring grooves until the end gaps are positioned at the bottom of the piston.

PISTON RING REPLACEMENT

1. Remove the piston from the engine block (see **CRANKSHAFT AND PISTON REMOVAL**).
2. Using a ring expander (A), remove the old piston rings (B).

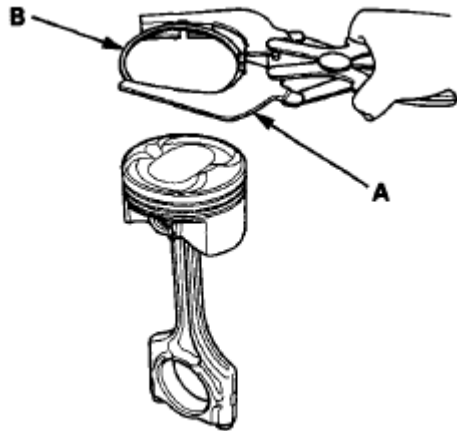

Fig. 44: Removing Piston Using Ring Expander
 Courtesy of AMERICAN HONDA MOTOR CO., INC.

3. Clean all ring grooves thoroughly with a squared-off broken ring or ring groove cleaner with a blade that fits the piston grooves.

The top and 2nd ring grooves are 1.2 mm (0.05 in) wide. The oil ring groove is 2.0 mm (0.08 in) wide.

File down a blade if necessary.

Do not use a wire brush to clean the ring grooves, or cut the ring grooves deeper with the cleaning tools.

NOTE: If the piston is to be separated from the connecting rod, do not install new rings yet.

4. Using a piston that has its rings removed, push a new ring (A) into the cylinder bore 15-20 mm (0.6-0.8 in) from the bottom.

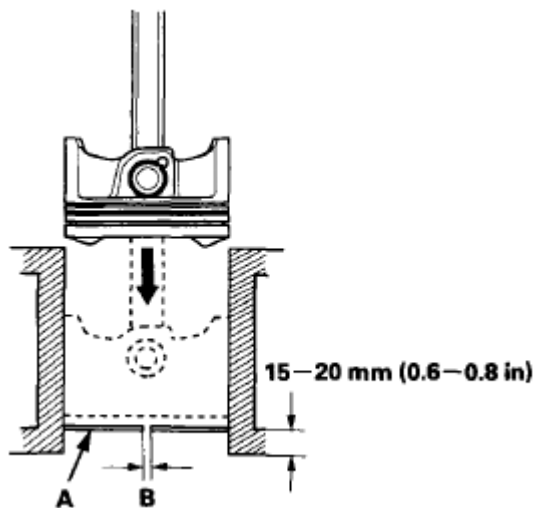

Fig. 45: Pushing Ring Into Cylinder

Courtesy of AMERICAN HONDA MOTOR CO., INC.

5. Measure the piston ring end-gap (B) with a feeler gauge:
 - If the gap is too small, check to see if you have the proper rings for your engine.
 - If the gap is too large, recheck the cylinder bore diameter against the wear limits (see **BLOCK AND PISTON INSPECTION**). If the bore is beyond the service limit, the engine block must be rebored.

Piston Ring End-Gap

Top Ring:

Standard (New): 0.20-0.35 mm (0.008-0.014 in)

Service Limit: 0.60 mm (0.024 in)

Second Ring:

Standard (New): 0.40-0.55 mm (0.016-0.022 in)

Service Limit: 0.70 mm (0.028 in)

Oil Ring:

Standard (New): 0.25-0.65 mm (0.010-0.026 in)

Service Limit: 0.75 mm (0.030 in)

6. Install the top ring and the second ring as shown. The top ring (A) has a 1R mark, and the second ring (B) has a 2R mark. The manufacturing marks (C) must face upward.

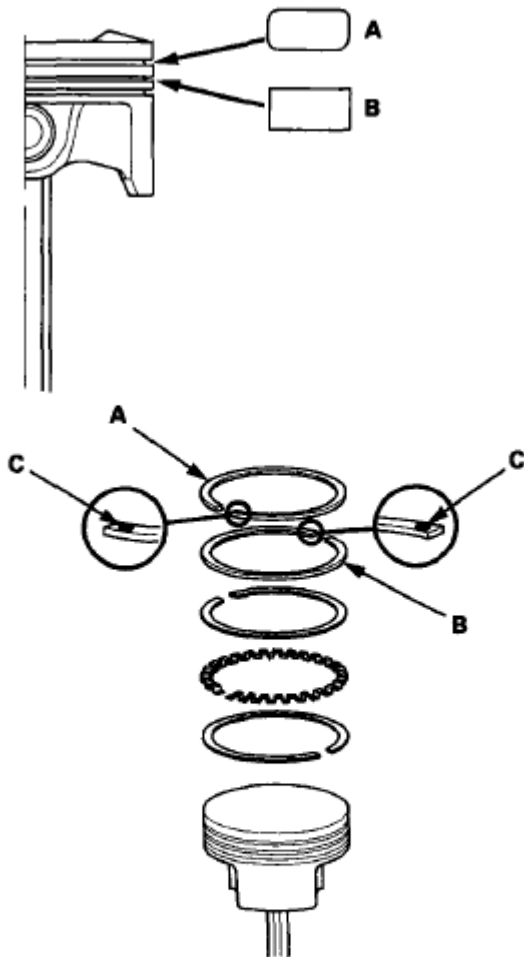

Piston Ring Dimensions

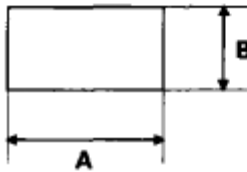

Top Ring (Standard):
A: 3.1 mm (0.12 in)
B: 1.2 mm (0.05 in)

Second Ring (Standard):
A: 3.4 mm (0.13 in)
B: 1.2 mm (0.05 in)

Fig. 46: Identifying Top Ring And Second Ring
 Courtesy of AMERICAN HONDA MOTOR CO., INC.

7. After installing a new set of rings, measure the ring-to-groove clearances:

Top Ring Clearance

Standard (New): 0.035-0.060 mm (0.0014-0.0024 in)

Service Limit: 0.13 mm (0.005 in)

Second Ring Clearance

Standard (New): 0.030-0.055 mm (0.0012-0.0022 in)

Service Limit: 0.13 mm (0.005 in)

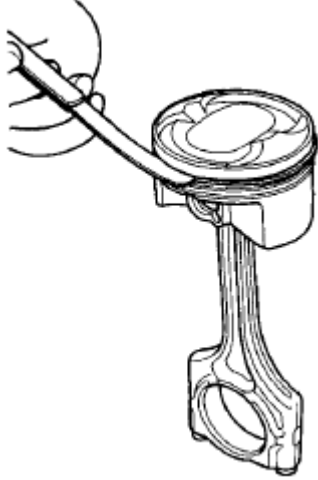

Fig. 47: Measuring Ring-To-Groove Clearances
Courtesy of AMERICAN HONDA MOTOR CO., INC.

8. Rotate the rings in their grooves to make sure they do not bind.
9. Position the ring end gaps as shown:

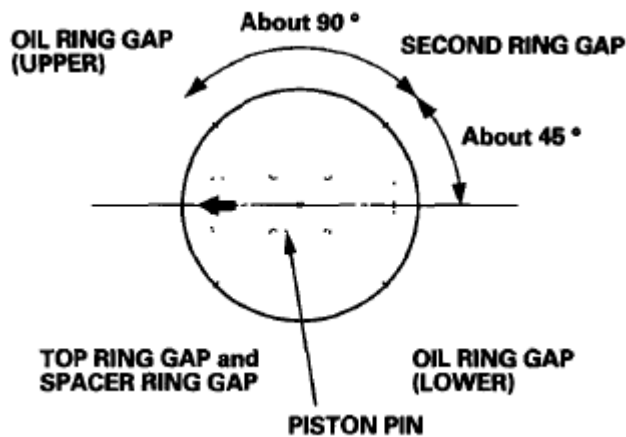

Fig. 48: Positioning Ring End Gaps
Courtesy of AMERICAN HONDA MOTOR CO., INC.

PISTON INSTALLATION

IF THE CRANKSHAFT IS ALREADY INSTALLED

1. Set the crankshaft to bottom dead center (BDC) for each cylinder as its piston is installed.
2. Remove the connecting rod caps, then install the ring compressor. Check that the bearing is securely in

place.

3. Apply new engine oil to the piston, inside of the ring compressor, and the cylinder bore, then attach the ring compressor to the piston/connecting rod assembly.
4. Position the mark (A) to face the cam chain side of the engine.

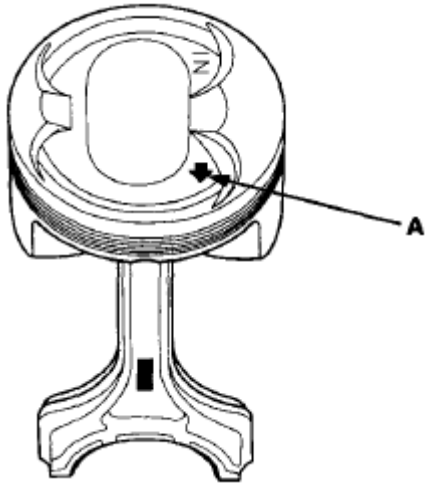

Fig. 49: Identifying Piston Mark Location

Courtesy of AMERICAN HONDA MOTOR CO., INC.

5. Position the piston in the cylinder, and tap it in using the wooden handle of a hammer (A).

Maintain downward force on the ring compressor (B) to prevent the rings from expanding before entering the cylinder bore.

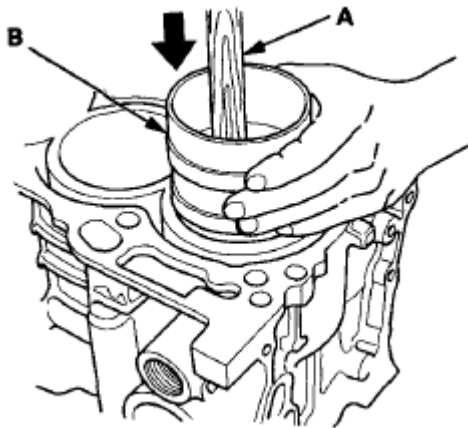

Fig. 50: Installing Piston Ring Using Piston Ring Compressor

Courtesy of AMERICAN HONDA MOTOR CO., INC.

6. Stop after the ring compressor pops free, and check the connecting rod-to-crank journal alignment before pushing the piston into place.
7. Check the connecting rod bearing clearance with plastigage (see **CONNECTING ROD BEARING**

REPLACEMENT).

8. Inspect the connecting rod bolts (see **IF THE CRANKSHAFT IS NOT INSTALLED**).
9. Install the rod caps with bearings. Torque the bolts to 20 N.m (2.0 kgf.m, 14 lbf.ft).
10. Tighten the connecting rod bolts an additional 90 °.

NOTE: Remove the connecting rod bolt if you tightened it beyond the specified angle, and go back to step 8 of the procedure. Do not loosen it back to the specified angle.

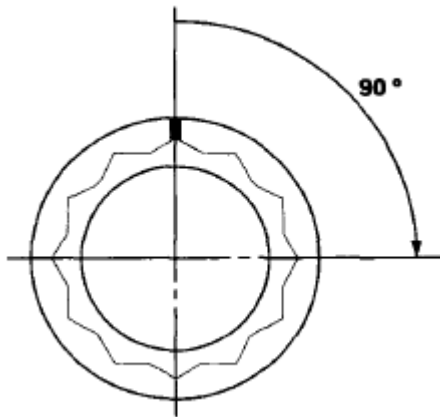

Fig. 51: Tightening Connecting Rod Bolts
Courtesy of AMERICAN HONDA MOTOR CO., INC.

IF THE CRANKSHAFT IS NOT INSTALLED

1. Remove the connecting rod caps, then install the ring compressor, and check that the bearing is securely in place.
2. Apply new engine oil to the piston, inside of the ring compressor, and the cylinder bore, then attach the ring compressor to the piston/connecting rod assembly.
3. Position the mark (A) to face the cam chain side of the engine.

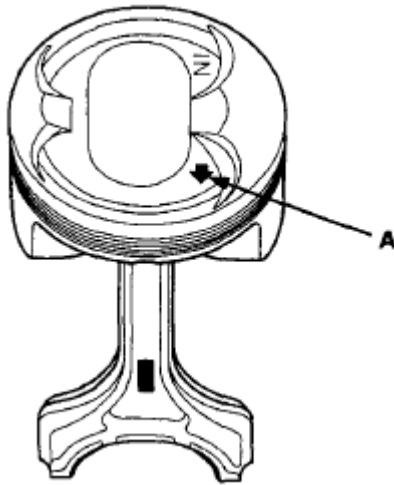

Fig. 52: Identifying Piston Mark Location
 Courtesy of AMERICAN HONDA MOTOR CO., INC.

4. Position the piston in the cylinder, and tap it in using the wooden handle of a hammer (A).

Push down on the ring compressor (B) to prevent the rings from expanding before entering the cylinder bore.

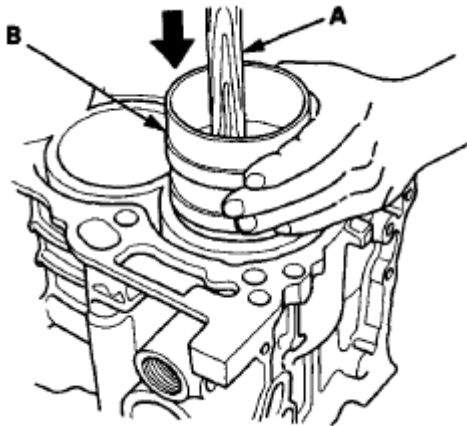

Fig. 53: Installing Piston Ring Using Piston Ring Compressor
 Courtesy of AMERICAN HONDA MOTOR CO., INC.

5. Position all pistons at top dead center (TDC).

CONNECTING ROD BOLT INSPECTION

1. Measure the diameter of each connecting rod bolt at point A and point B.

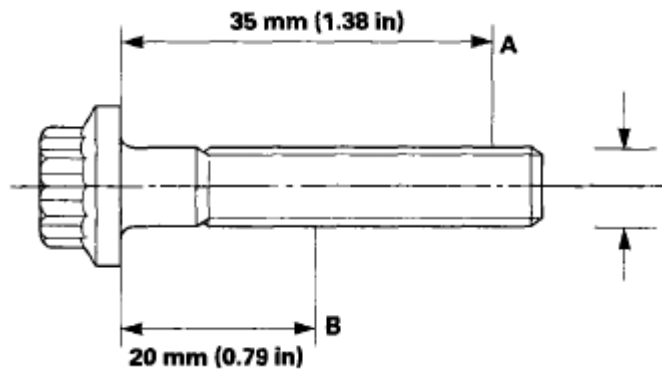

Fig. 54: Identifying Connecting Rod Bolt Dimension
 Courtesy of AMERICAN HONDA MOTOR CO., INC.

2. Calculate the difference in diameter between point A and point B.

Point A-Point B = Difference in Diameter

Difference in Diameter

Specification: 0-0.1 mm (0-0.004 in)

3. If the difference in diameter is out of specification, replace the connecting rod bolt.

CRANKSHAFT INSTALLATION

Special Tools Required

- Driver Handle, 15 x 135L 07749-0010000
- Oil Seal Driver Attachment, 96 mm 07ZAD-PNAA100

1. Check the connecting rod bearing clearance with plastigage (see **CONNECTING ROD BEARING REPLACEMENT**).
2. Check the main bearing clearance with plastigage (see **CRANKSHAFT MAIN BEARING REPLACEMENT**).
3. Install the bearing halves in the engine block and connecting rods.
4. Apply a coat of new engine oil to the main bearings and rod bearings.
5. Hold the crankshaft so that rod journal No. 2 and rod journal No. 3 are straight up, and lower the crankshaft into the block.
6. Apply new engine oil to the thrust washer surfaces. Install the thrust washers (A) in the No. 4 journal of the engine block.

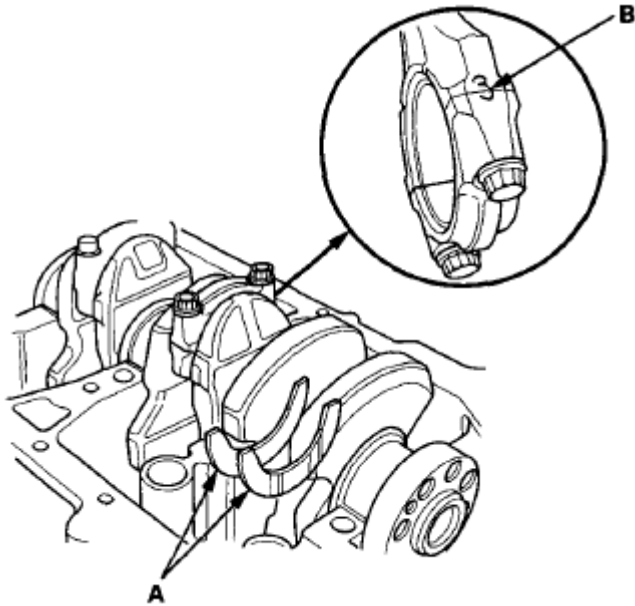

Fig. 55: Identifying Connecting Rod Line Up Mark On Connecting Rod And Cap
 Courtesy of AMERICAN HONDA MOTOR CO., INC.

7. Inspect the connecting rod bolts (see **IF THE CRANKSHAFT IS NOT INSTALLED**).
8. Apply engine oil to the threads of the connecting rod bolts.
9. Seat the rod journals into connecting rod No. 1 and connecting rod No. 4. Line up the mark (B) on the connecting rod and cap, then install the caps and bolts finger-tight.
10. Rotate the crankshaft clockwise, and seat the journals into connecting rod No. 2 and connecting rod No. 3. Line up the mark on the connecting rod and cap, then install the caps and bolts finger-tight.
11. Torque the connecting rod bolts to 20 N.m (2.0 kgf.m, 14 lbf.ft).
12. Tighten the connecting rod bolts an additional 90 °.

NOTE: Remove the connecting rod bolt if you tightened it beyond the specified angle, and go back to step 7 of the procedure. Do not loosen it back to the specified angle.

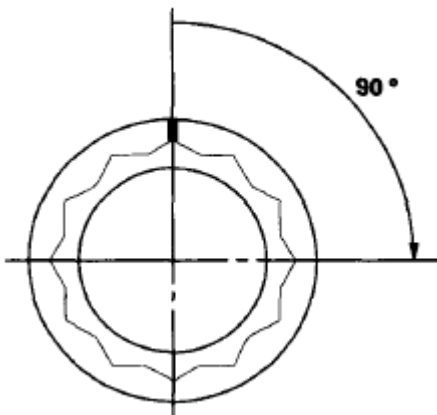

Fig. 56: Tightening Connecting Rod Bolts

Courtesy of AMERICAN HONDA MOTOR CO., INC.

13. Remove all of the old liquid gasket from the lower block mating surfaces, bolts, and bolt holes.
14. Clean and dry the lower block mating surfaces.
15. Apply liquid gasket (P/N 08717-0004, 08718-0003, or 08718-0009) to the engine block mating surface of the lower block and to the inside edge of the bolt holes. Install the component within 5 minutes of applying the liquid gasket.

NOTE:

- Apply a 3 mm (0.12 in) diameter bead of liquid gasket along the broken line (A).
- If too much time has passed after applying the liquid gasket, remove the old liquid gasket and residue, then reapply new liquid gasket.

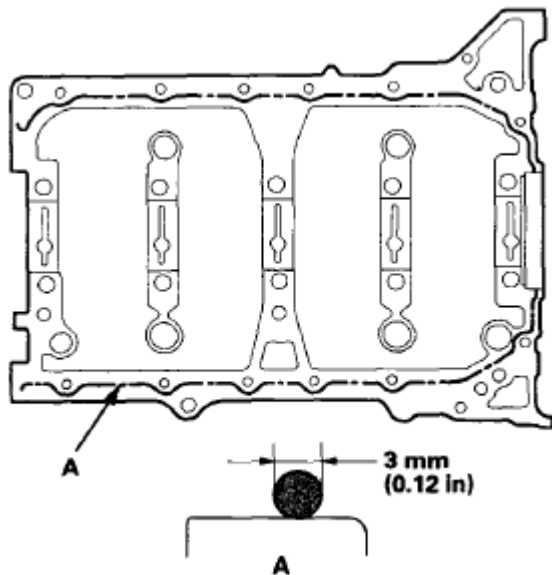
**Fig. 57: Identifying Engine Block Mating Surface Sealant Area**

Courtesy of AMERICAN HONDA MOTOR CO., INC.

16. Put the lower block on the engine block.
17. Apply new engine oil to the threads of the bearing cap bolts.
18. Torque the bearing cap bolts, in sequence, to 29 N.m (3.0 kgf.m, 22 lbf.ft).

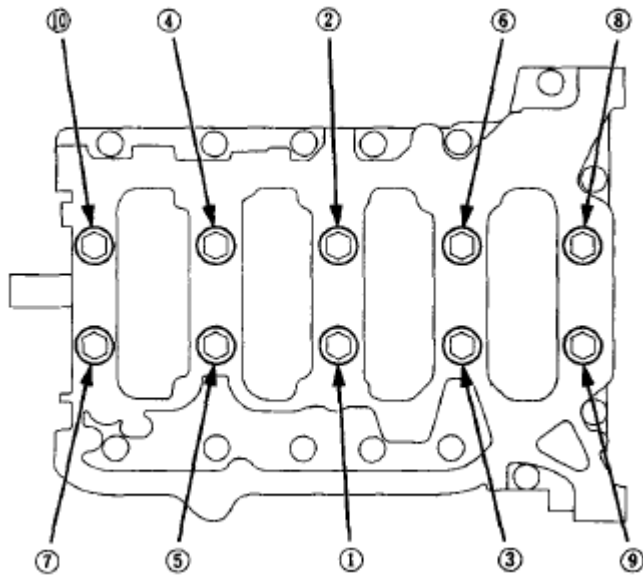

Fig. 58: Identifying Bearing Cap Bolts Tighten Sequence
 Courtesy of AMERICAN HONDA MOTOR CO., INC.

19. Tighten the bearing cap bolts an additional 56° .

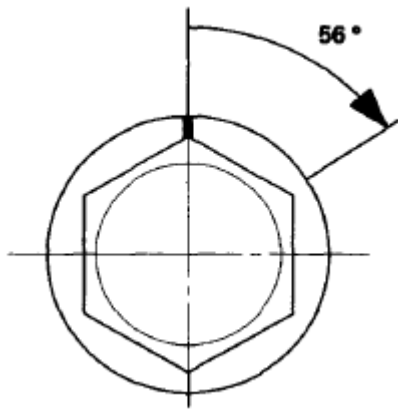

Fig. 59: Tightening Bearing Cap Bolts
 Courtesy of AMERICAN HONDA MOTOR CO., INC.

20. Torque the 8 mm bolts, in sequence, to 22 N.m (2.2 kgf.m, 16 lbf.ft).

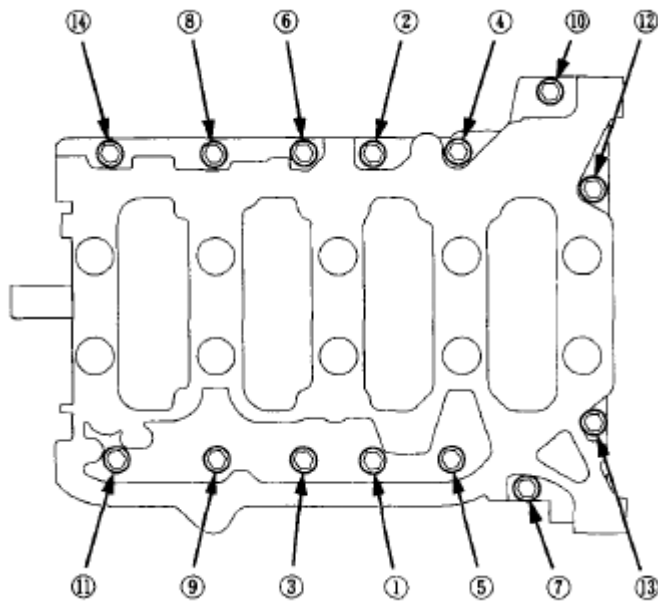

Fig. 60: Identifying Bearing Cap Bolts Tighten Sequence
 Courtesy of AMERICAN HONDA MOTOR CO., INC.

21. Apply a light coat of new engine oil to the lip of the crankshaft oil seal.
22. Use the driver and attachment to drive a new oil seal squarely into the block to the specified installed height.

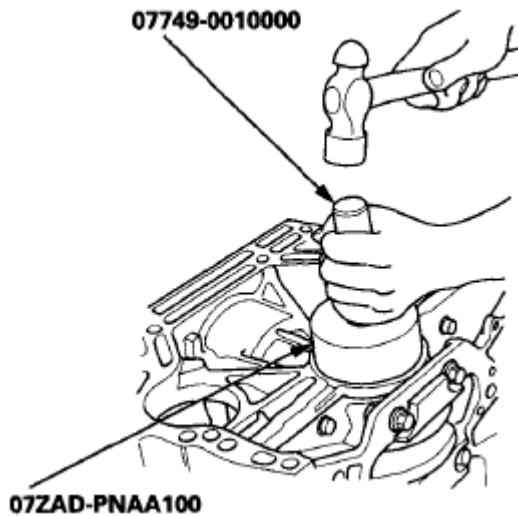

Fig. 61: Installing Oil Seal
 Courtesy of AMERICAN HONDA MOTOR CO., INC.

23. Measure the distance between the engine block (A) and the oil seal (B).

Oil Seal Installed Height: 0.2-1.2 mm (0.001-0.047 in)

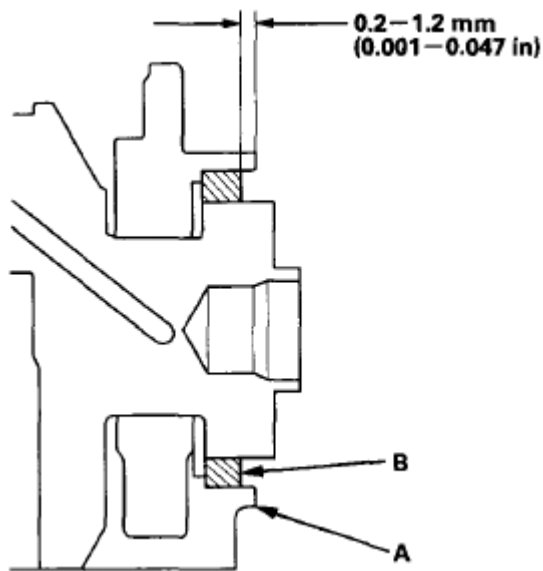

Fig. 62: Measuring Distance Between Engine Block And Oil Seal
 Courtesy of AMERICAN HONDA MOTOR CO., INC.

24. Install the baffle plates.

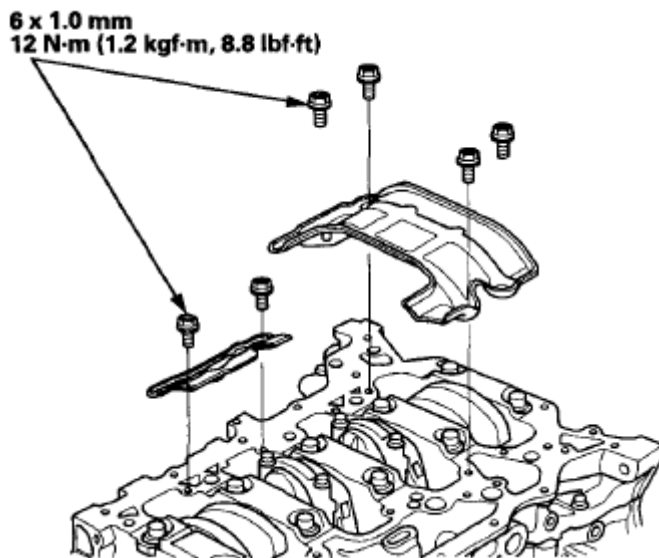

Fig. 63: Identifying Baffle Plates And Bolts
 Courtesy of AMERICAN HONDA MOTOR CO., INC.

25. Install the oil pump (see [OIL PUMP INSTALLATION](#)).
 26. Install the oil pan (see [OIL PAN INSTALLATION](#)).
 27. Install the cylinder head (see [CYLINDER HEAD INSTALLATION](#)).
 28. Install the drive plate (see [DRIVE PLATE REMOVAL AND INSTALLATION](#)).
 29. Install the transmission (see [TRANSMISSION INSTALLATION](#)).

30. Install the engine assembly (see **ENGINE INSTALLATION**).

NOTE: Whenever any crankshaft or connecting rod bearing is replaced, it is necessary after reassembly to run the engine at idle speed until it reaches normal operating temperature, then continue running it for about 15 minutes.

OIL PAN INSTALLATION

1. Remove all of the old liquid gasket from the oil pan mating surfaces, bolts, and bolt holes.
2. Clean and dry the oil pan mating surfaces.
3. Apply liquid gasket (P/N 08717-0004, 08718-0003, or 08718-0009) to the engine block mating surface of the oil pan and to the inside edge of the bolt holes. Install the component within 5 minutes of applying the liquid gasket.

- NOTE:**
- Apply a 3 mm (0.12 in) diameter bead of liquid gasket along the broken line (A).
 - If too much time has passed after applying the liquid gasket, remove the old liquid gasket and residue, then reapply new liquid gasket.

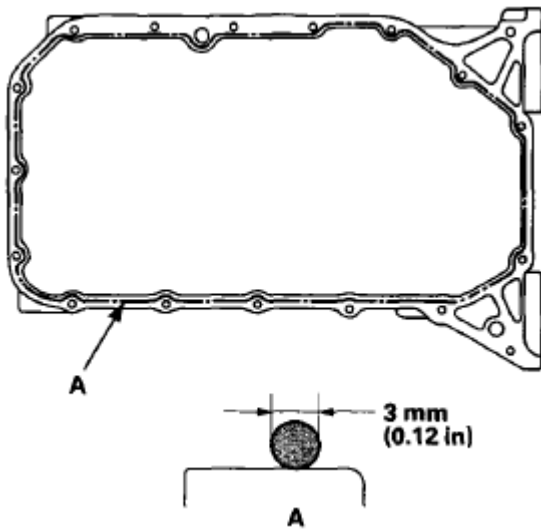

Fig. 64: Identifying Engine Block Mating Surface Sealant Area
Courtesy of AMERICAN HONDA MOTOR CO., INC.

4. Install the oil pan.
5. Tighten the bolts in three steps. In the final step, tighten all bolts, in sequence, to 12 N.m (1.2 kgf.m, 8.8 lbf.ft). Wipe off the excess liquid gasket on the each side of crankshaft pulley and drive plate.

- NOTE:**
- Wait at least 30 minutes to allow the liquid gasket to cure before filling the engine with oil.

- Do not run the engine for at least 3 hours after installing the oil pan.

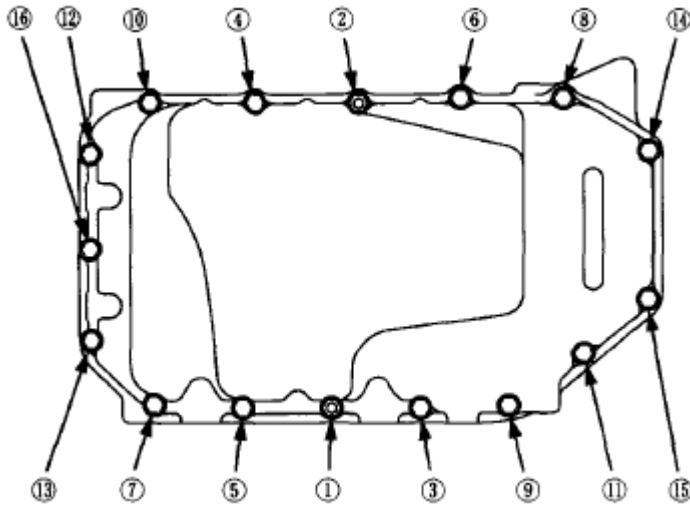

Fig. 65: Identifying Oil Pan Tighten Sequence
 Courtesy of AMERICAN HONDA MOTOR CO., INC.

6. Install the torque converter cover.

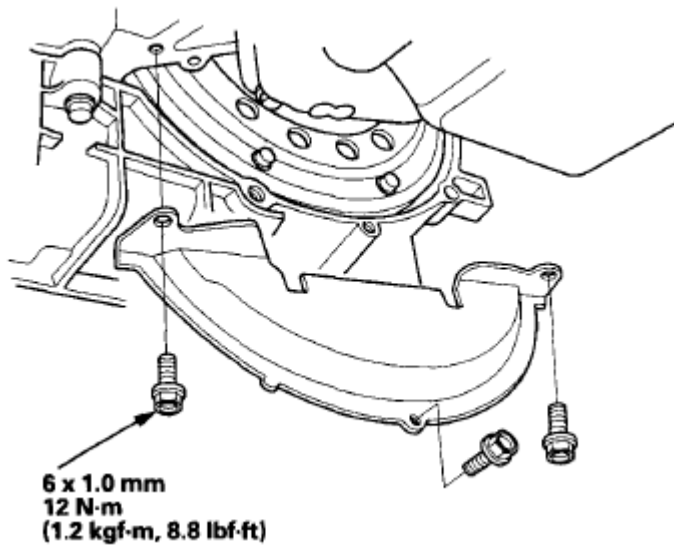

Fig. 66: Identifying Torque Converter Cover And Bolts With Torque Specification
 Courtesy of AMERICAN HONDA MOTOR CO., INC.

7. Install the lower torque rod bracket.

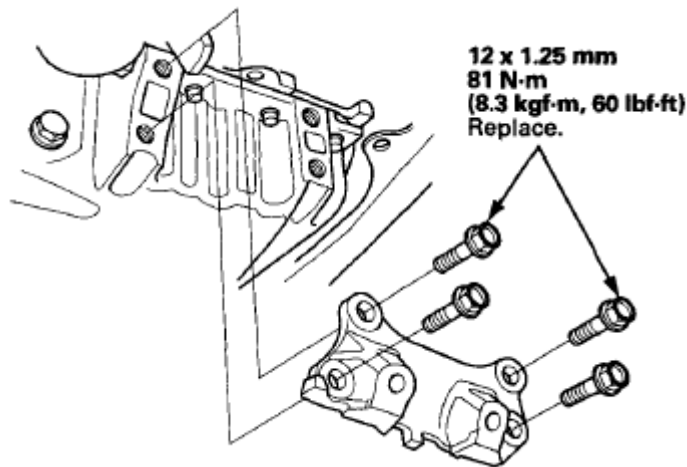

Fig. 67: Identifying Lower Torque Rod Bracket With Torque Specification
 Courtesy of AMERICAN HONDA MOTOR CO., INC.

8. If the engine is still in the vehicle, do steps 9 through 31.
9. Using the subframe adapter and a jack, raise the subframe up to body (see step 17 under **ENGINE INSTALLATION**).
10. Loosely install the new 14 x 1.5 mm bolts (see step 18 under **ENGINE INSTALLATION**).
11. Align all reference marks on the front subframe with the body, then tighten the bolts on the front subframe to the specified torque (see step 19 under **ENGINE INSTALLATION**).
12. Tighten the new subframe mounting bolts on both side (see step 20 under **ENGINE INSTALLATION**).
13. Lower the vehicle on the lift.
14. Loosen the upper torque rod mounting bolt (see step 8 under **ENGINE INSTALLATION**).
15. Raise the vehicle on the lift.
16. Install the lower torque rod, then tighten the new lower torque rod mounting bolts in the numbered sequence shown (see step 21 under **ENGINE INSTALLATION**).
17. Lower the vehicle on the lift.
18. Tighten the upper torque rod mounting bolt (see step 24 under **ENGINE INSTALLATION**).
19. Install the automatic transmission fluid (ATF) filter.

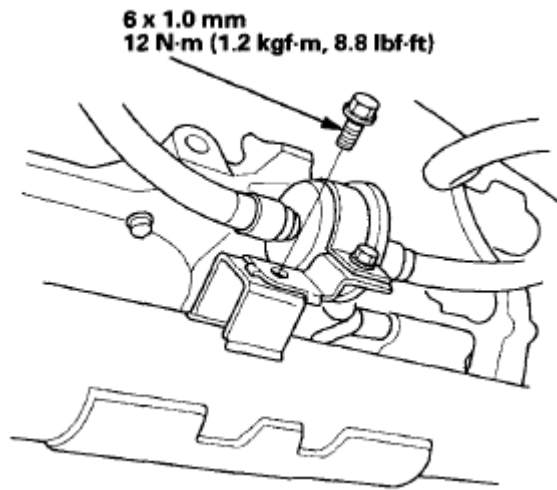

Fig. 68: Identifying Automatic Transmission Fluid Filter With Torque Specification
Courtesy of AMERICAN HONDA MOTOR CO., INC.

20. Install the bolts securing the left steering gearbox mounting bracket (see step 28 under **ENGINE INSTALLATION**).
21. Install the bolts securing the right steering gearbox mounting bracket (see step 29 under **ENGINE INSTALLATION**).
22. Install the power steering (P/S) fluid line bracket and secure the hose with the hose clamps (see step 30 under **ENGINE INSTALLATION**).
23. 4WD model: Install the propeller shaft (see **PROPELLER SHAFT INSTALLATION**).
24. Install a new set ring on the end of each driveshaft, then install the driveshafts. Make sure each ring "clicks" into place in the differential and intermediate shaft.
25. Connect the lower arms to the knuckles (see step 8 under **LOWER ARM REMOVAL/INSTALLATION**).
26. Connect the stabilizer links to the stabilizer bar.
27. Install the shift cable (see step 39 under **TRANSMISSION INSTALLATION**).
28. Install the three way catalytic converter (TWC). Use new gaskets and new self-locking nuts. Connect the air fuel ratio (A/F) sensor connector and secondary heated oxygen sensor (secondary HO2S) connector (see step 36 under **ENGINE INSTALLATION**).
29. Install the splash shield (see step 37 under **ENGINE INSTALLATION**).
30. Install the front wheels.
31. Check the wheel alignment (see **WHEEL ALIGNMENT**).

TRANSMISSION END CRANKSHAFT OIL SEAL INSTALLATION - IN CAR

Special Tools Required

- Driver Handle, 15 x 135L 07749-0010000
- Oil Seal Driver Attachment, 96 mm 07ZAD-PNAA100

1. Remove the transmission (see **TRANSMISSION REMOVAL**).
2. Remove the drive plate (see **DRIVE PLATE REMOVAL AND INSTALLATION**).
3. Clean and dry the crankshaft oil seal housing.
4. Apply a light coat of new engine oil to the lip of the crankshaft oil seal.
5. Use the driver and attachment to drive a new oil seal squarely into the block to the specified installed height.

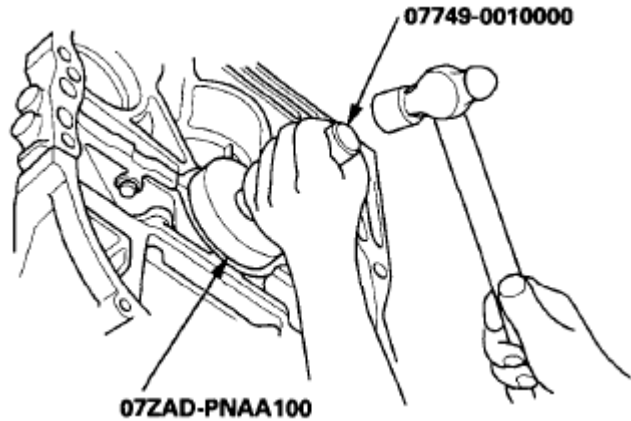

Fig. 69: Installing Oil Seal

Courtesy of AMERICAN HONDA MOTOR CO., INC.

6. Measure the distance between the engine block (A) and the oil seal (B).

Oil Seal Installed Height: 0.2-1.2 mm (0.001-0.047 in)

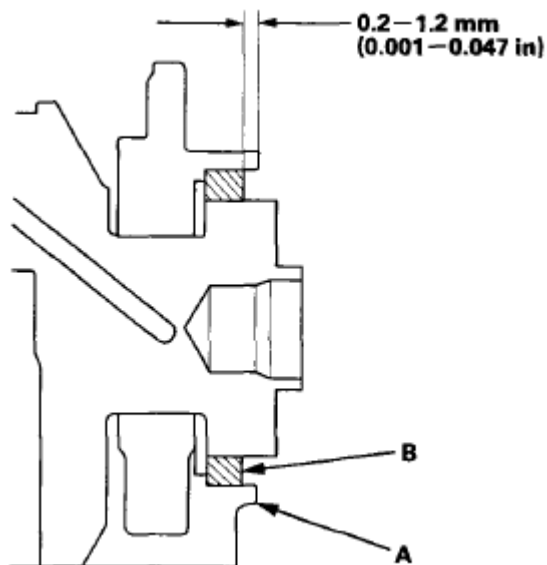

Fig. 70: Measuring Distance Between Engine Block And Oil Seal

Courtesy of AMERICAN HONDA MOTOR CO., INC.

7. Install the drive plate (see DRIVE PLATE REMOVAL AND INSTALLATION).
8. Install the transmission (see DRIVE PLATE REMOVAL AND INSTALLATION).

SEALING BOLT INSTALLATION

NOTE: When installing the sealing bolt (A), always use a new washer.

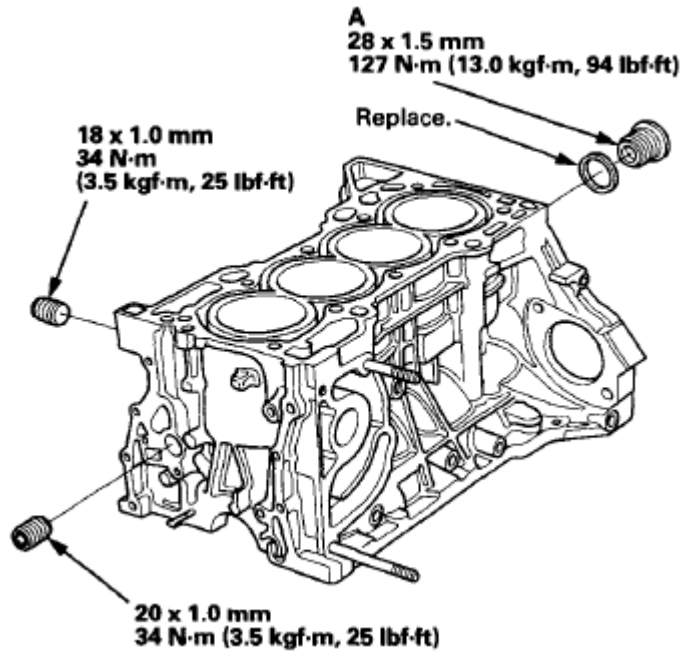

Fig. 71: Identifying Sealing Bolt And Washer With Torque Specifications
Courtesy of AMERICAN HONDA MOTOR CO., INC.