



This manual deals with the operation and care of your Volvo.



Welcome to the world-wide family of Volvo owners. We trust that you will enjoy many years of safe driving in your Volvo, an automobile designed with your safety and comfort in mind. To help ensure your satisfaction with this vehicle, we encourage you to familiarize yourself with the equipment descriptions, operating instructions and maintenance requirements/recommendations in this manual. We also urge you and your passengers to wear seat belts at all times in this (or any other) automobile. And, of course, please do not operate a vehicle if you may be affected by alcohol, medication or any impairment that could hinder your ability to drive.

Your Volvo is designed to meet all applicable safety and emission standards, as evidenced by the certification labels attached to the driver's door opening and on the left wheel housing in the engine

compartment.

Volvo and the environment

Volvo is committed to the well being of our customers. As a natural part of this commitment, we care about the environment in which we all live. Caring for the environment means an everyday involvement in reducing our environmental impact.

Volvo's environmental activities are based on a holistic view, which means we consider the overall environmental impact of a product throughout its complete life cycle. In this context, design, production, product use, and recycling are all important considerations.

In production, Volvo has partly or completely phased out several chemicals including freons, lead chromates, naphatanates, asbestos, mercury and cadmium; and reduced the amount of chemicals used in our plants 50% since 1991.

In use, Volvo was the first in the world to introduce into production a three-way catalytic converter with a Lambda sond, now called oxygen sensor, in 1976. The current version of this highly efficient system reduces emissions of harmful substances (CO, HC, NOx) from the exhaust pipe by approximately 95% and the search to eliminate the remaining emissions continues. Volvo is the only automobile manufacturer to offer CFC-free retrofit kits for the air conditioning system for all models back to the M/Y 1975 240. Advanced electronic engine controls, refined purification systems and cleaner fuels are bringing us closer to our goal.

After Volvo cars and parts have fulfilled their use, recycling is the next critical step in completing the life cycle. The metal content is about 75% of the total weight of the car, which makes the car among the most recycled industrial products. In order to have efficient and well controlled recycling, many Volvo variants have printed dismantling manuals indication the weight and material of individual components. For Volvo, all homogeneous plastic parts weighing more than 1.7 oz. (50 grams) are marked with international symbols that indicate how the component is to be sorted for recycling.

In addition to continuous environmental refinement of conventional gasoline-powered internal combustion engines, Volvo is actively looking at advanced technology alternative-fuel vehicles.

When you drive a Volvo, you become our partner in the work to lessen the car's impact on the environment.

To reduce your vehicle's environmental impact, you can:

- Maintain proper air pressure in your tires. Tests have shown decreased fuel economy with improperly inflated tires
- Follow the recommended maintenance schedule

- Drive at a constant speed
- See an authorized Volvo retailer as soon as possible for inspection if the check engine (malfunction indicator) lamp illuminates, or stays on after the vehicle has started
- Properly dispose of any vehicle related waste such as used motor oil, used batteries, brake pads, etc.
- When cleaning your car, use Volvo's own car care products, all of which have systematically been adapted to the environment.

Contents

Important

Before you operate your car for the first time, please familiarize yourself with the [BREAK-IN information on page 58](#). You should also be familiar with the information in the first three chapters of this manual.

Information contained in the balance of the manual is extremely useful and should be studied after operating the vehicle for the first time.

This manual is structured so that it can be used for reference. It should thus be kept in the car for ready access.

Do not export your Volvo to another country before investigating the country's applicable safety and exhaust emission requirements. In some cases it may be difficult or impossible to comply with these requirements. Modifications to the emission control system(s) may render your Volvo not certifiable for legal operation in the U.S., Canada or other countries.

All information, illustrations and specifications contained in this manual are based on the latest product information available at the time of publication. Volvo reserves the right to make model changes at any time, or to change specifications or design, without notice and without incurring obligation.

CAUTION: Certain models have reduced ground clearance due to the design of the front spoiler. Please observe caution when e.g., driving onto garage hoists, through drifted snow or when other road debris is encountered, or when parking near curbs

©1997 Volvo Cars of North America Inc.

Contents

[Chapter 1 - Occupant safety](#) [1](#)

[Chapter 2 - Instruments, switches and controls](#) [15](#)

<u>Chapter 3 - Body and interior</u>	<u>39</u>
<u>Chapter 4 - Starting and driving</u>	<u>57</u>
<u>Chapter 5 - Wheels and tires</u>	<u>77</u>
<u>Chapter 6 - In case of an emergency</u>	<u>83</u>
<u>Chapter 7 - Car care</u>	<u>101</u>
<u>Chapter 8 - Volvo Service</u>	<u>107</u>
<u>Chapter 9 - Specifications</u>	<u>125</u>
<u>Chapter 10 - Audio systems</u>	<u>133</u>
<u>Index</u>	<u>190</u>



[Top of Page](#)

Chapter 1 - Occupant safety

pg. 1 Occupant safety

Occupant safety

Despite our strongest recommendations, and your best intentions, not wearing a seat belt is like believing "It'll never happen to me!". Volvo urges you and all adult occupants of your car to wear seat belts and ensure that children are properly restrained, using an infant, car or booster seat determined by age, weight and height.

Fact: In every state and province, some type of child-restraint legislation has been passed. Additionally, most states and provinces have already made it mandatory for occupants of a car to use seat belts. So, urging you to "buckle up" is not just our recommendation - legislation in your state or province may mandate seat belt usage. The few seconds it takes to buckle up may one day allow you to say, "It's a good thing I was wearing my seat belt".



<u>Seat belts</u>	<u>2</u>
<u>Volvo SRS</u>	<u>4</u>
<u>Side Impact Protection System - (SIPS) air bag</u>	<u>8</u>
<u>Roll Over Protection System (ROPS)</u>	<u>9</u>
<u>Child safety</u>	<u>10</u>
<u>Occupant safety</u>	<u>13</u>
<u>Reporting Safety Defects</u>	<u>13</u>

pg. 2 Seat belts

Seat belts

Always fasten the seat belts before you drive or ride.

Two lights above the rear view mirror will be illuminated for 4-8 seconds after the starting (ignition) key is turned to the driving position. A chime will sound at the same time if the driver has not fastened his seat belt. The rear seats are provided with self-retracting inertia reel belts. The front seats are provided with single roller belts with tensioners.

Adjusting the shoulder belt

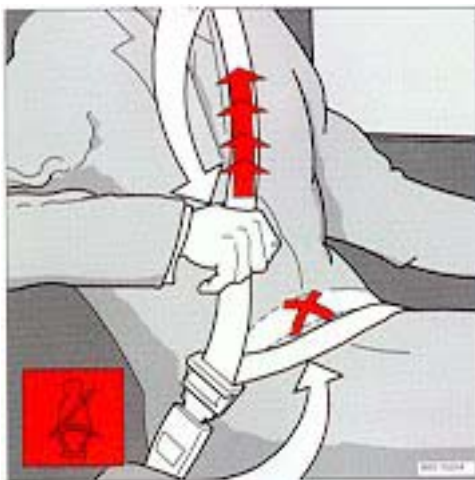

Lap portion of the seat belt should sit low

To buckle:

Pull the belt out far enough to insert the latch plate into the receptacle (buckle for rear seats) until a distinct snapping sound is heard. The seat belt retractor is normally "unlocked" and you can move freely, provided that the shoulder belt is not pulled out too far. The retractor will lock up as follows:

- if the belt is pulled out rapidly
- during braking and acceleration
- if the vehicle is leaning excessively
- when driving in turns

For the seat belt to provide maximum protection in the event of an accident, it must be worn correctly.

When wearing the seat belt remember:

- The belt should not be twisted or turned.
- The lap belt must be positioned low on the hips (not pressing against the abdomen).
- The shoulder section of the front seat belts adjusts automatically to the driver's height.

Make sure that the shoulder belt is rolled up into its retractor and that the shoulder and lap belts are taut.

Before exiting the car, check that the seat belt retracts fully after being unbuckled.

If necessary, guide the belt back into the retractor slot.

NOTE: Legislation in your state or province may mandate seat belt usage.

[For information on securing child seats, please refer to page 11.](#)

WARNING!

- Any device used to induce slack into the shoulder belt portion of the three-point belt system will have a detrimental effect on the amount of protection available to you in the event of a collision. The seat back should not be tilted too far back. The shoulder belt must be taut in order to function properly.
- Do not use child safety seats or child booster cushions/backrests in the front passenger's seat. We also recommend that children who have outgrown these devices sit in the rear with the seat belt properly fastened.
- The rear seat of the Volvo C 70 is intended for two occupants only. Only two three-point seat belts are provided. The center position should never be used to seat a passenger.

pg. 3 Seat belts



During pregnancy

Pregnant women should always wear seat belts. Remember that the belt should always be positioned in such a way as to avoid any possible pressure on the abdomen. The lap portion of the belt should be located low, as shown in the above illustration.

WARNING!

- The rear seat of the Volvo C 70 is intended for two occupants only. Only two three-point seat belts are provided. The center position should never be used to seat a passenger.
- Never use a seat belt for more than one occupant.
- Never wear the shoulder portion of the belt under the arm, behind the back or otherwise out of position. Such use could cause injury in event of accident.
- As the seat belts lose much of their strength when exposed to violent stretching, they should be replaced after any collision, even if they may appear to be undamaged.
- Never repair the belt on your own; have this done by an authorized Volvo retailer only.
- Any device used to induce slack into the shoulder belt portion of the three-point belt system will have a detrimental effect on the amount of protection available to you in the event of a collision.
- The seat back should not be tilted too far back. The shoulder belt must be taut in order to function properly.



[Contents](#) | [Top of Page](#)

pg. 4 Volvo SRS

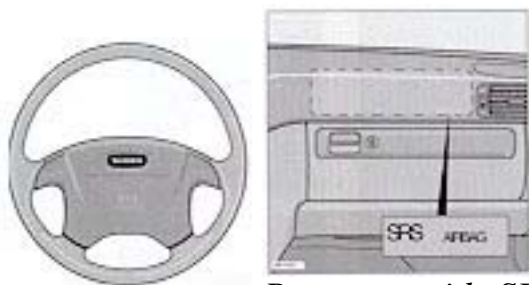
*Passenger side SRS hatch*

As an enhancement to the three-point seat belt system, your Volvo is equipped with a Supplemental Restraint System (SRS). The Volvo SRS consists of an airbag (2) and knee bolster (5) on both the driver's and passenger's sides and seat belt tensioners in both front door pillars (4). The system is designed to supplement the protection provided by the three-point seat belt system.

The SRS system is indicated by the "SRS" embossed on the steering wheel pad and above the glove compartment, the knee bolsters beneath the steering column and the glove compartment and decals on both sun visors and on the far right side of the dash.

The airbags are folded and located in the center of the steering wheel and above the glove compartment. They are designed to deploy during certain frontal-angular collisions, impacts, or decelerations, depending on the crash severity, angle, speed and object impacted. The airbags may also deploy in certain non-frontal collisions where rapid deceleration occurs. Both airbags and seat belt tensioners will deploy, even if the passenger seat is not occupied.

WARNING! As its name implies, SRS is designed to be a SUPPLEMENT to - not a replacement for - the three-point belt system. For maximum protection, wear seat belts at all times. Be aware that no system can prevent all possible injuries that may occur in an accident.



The airbag system includes gas generators (1) surrounded by the airbags (2) and front seat belt

ensioners for both of the front seats (4). To deploy the system, the sensor (3) activates the gas generators causing the airbags to be inflated with nitrogen gas. As the movement of the seat's occupants compresses the airbags, some of the gas is expelled at a controlled rate to provide better cushioning. Both seat belt tensioners also deploy, minimizing any seat belt slack.

The entire process, including inflation and deflation of the airbags, takes approximately two-tenths of a second.

WARNING! When installing any optional equipment, make sure that the SRS system is not damaged. Do not attempt to service any component of the SRS yourself. Attempting to do so may result in serious personal injury. If a problem arises, take your car to the nearest authorized Volvo retailer for inspection as soon as possible.

pg. 5 Volvo SRS



A self-diagnostic system incorporated in the sensor monitors the SRS. This system does not, however, monitor the SIPS airbags. If a fault is detected, the "SRS" warning light will illuminate. The light is included in the warning/indicator light cluster in the instrument panel. Normally, the SRS warning lamp should light up when the ignition is switched on and should go out after 10 seconds or when the engine is started. Check that this light is functioning properly every time the car is started.

The following items are monitored by all the self-diagnostic system:

- Sensor unit
- Cable harness
- Gas generator ignitors

WARNING!

Never drive an SRS equipped car with your hands on the steering wheel pad/airbag housing. No objects, accessory equipment or stickers may be placed on, attached to or installed near the SRS cover in the center of the steering wheel, the SRS cover above the glove compartment or the area affected by the airbag deployment.

If the SRS warning light stays on after the engine has started or if it comes on while you are driving, drive the car to the nearest authorized Volvo retailer for inspection as soon as possible.



The above is a sample of the label found on all seat belts equipped with tensioners, located on the front seat belts near the lower anchorage point.



The above is a sample of the decal which can be found on the driver's door pillar.

There is no maintenance to perform on the SRS yourself. The only periodic maintenance recommended on the SRS is that the air bag modules and front seat belts (including tensioners) should be replaced approximately every ten years and that the other components in the system (wiring, connectors, etc.) should also be inspected at this time. The SRS decal on your car shows the month and year servicing is due. This service must be performed by an authorized Volvo retailer.

Should you have any questions about the SRS system, please contact your authorized Volvo retailer or Volvo Customer Support.



SRS text at far right of instrument

*panel
Passenger side air bag*



SRS texts on inside of both sun visors



SRS texts on outside of both sun visors

WARNING! Do not use child safety seats or child boosters cushions/backrests in the front passenger's seat. We also recommend that children who have outgrown these devices sit in the rear seat with the seat belt properly fastened.

NOTE: Deployment of SRS components occurs only one time during an accident. In a collision where deployment occurs, the air bags and seat belt tensioners activate. Some noise occurs and a small amount of powder is released. The release of the powder may appear as smoke-like matter. This is a normal characteristic and does not indicate fire.

WARNING!

- Children must never be allowed in the front passenger seat. Volvo recommends that ALL occupants (adults and children) shorter than four feet seven inches (140 cm) be seated in the back seat of the vehicle with a front passenger side airbag. [See page 10 for guidelines.](#)
- Occupants in the front passenger's seat must never sit on the edge of the seat, sit leaning toward the instrument panel or otherwise sit out of position. The occupant's back must be as upright as comfort allows and be against the seat back with the seat belt properly fastened.
- Feet must be on the floor, e.g. not on the dash, seat or out of the window.
- No objects or accessory equipment, e.g. dash covers, may be placed on, attached to or installed near the SRS hatch (the area above the glove compartment) or the area affected by airbag deployment (see illustration).
- There should be no loose articles, e.g. coffee cups, on the floor, seat or dash area.
- Never try to open the SRS cover on the steering wheel or the passenger side SRS hatch. This should only be done by an authorized Volvo service technician.
- Failure to follow these instructions can result in injury to the vehicle occupants in an accident.

pg. 7 Volvo SRS (cont.)

NOTE: The information on this page does not pertain to the Side Impact protection System airbags.

When are the airbags deployed?

The SRS system is designed to deploy during certain frontal or front-angular collisions, impacts, or decelerations, depending in the crash severity, angle, speed, and object impacted. The SRS sensor is designed to react to both the impact of the collision and the inertial forces generated by it and to determine if the intensity of the collision is sufficient for the airbags to be deployed.

WARNING! The SRS is designed to help prevent serious injury. Deployment occurs very quickly and with considerable force. During normal deployment and depending on variables such as seating position, one may experience abrasions, bruises, swellings, or other injuries as a result of airbag(s) deployment.

If the airbags have been deployed, we recommend the following:

- Have the car towed to an authorized Volvo retailer. Never drive with the airbags deployed.
- Have an authorized Volvo retailer replace the SRS system components.
- Use only new, Genuine Volvo Parts when replacing SRS components (airbags, seat belts, tensioners, etc.)

When are the airbags NOT deployed?

Not all frontal collisions activate the SRS system. If the collision involves a non-rigid object (e.g., a snow drift or bush), or a rigid, fixed object at a low speed, the SRS system will not necessarily deploy.

Airbags do not normally deploy in a side impact collision, in a collision from the rear or in a rollover situation. The amount of damage to the bodywork does not reliably indicate if the airbags should have deployed or not.

Seat belts - the heart of the Volvo safety system

The heart of the Volvo safety system is the **three-point seat belt** (a Volvo invention)! In order for the SRS system to provide the protection intended, seat belts must be worn at all times by everyone in the car.

The SRS system is a supplement to the seat belts.

WARNING! If your car has been subjected to flood conditions (e.g. soaked carpeting/standing water on the floor of the vehicle) or if your car has become flood-damaged in any way, do not attempt to start the vehicle or put the key in the ignition before disconnecting the battery (see below). This may cause airbag deployment which could result in personal injury. Have the car towed to an authorized Volvo retailer for repairs.

Automatic transmission only:

Before attempting to tow the car, use the following procedure to override the shiftlock system to move the gear selector to the neutral position.

- Disconnect the battery
- Wait at least one minute
- Insert the key in the ignition and turn it to position 1
- Press firmly on the shiftlock override button (located near the base of the gear selector).
- While holding the override button down, move the gear selector from the park position.

WARNING! Never drive with the airbags deployed. The fact that they hang out can impair the steering of your car. Other safety systems can also be damaged. The smoke and dust formed when the airbags are deployed can cause skin and eye irritation in the event of prolonged exposure.



[Contents](#) | [Top of Page](#)

pg. 8 Volvo Side Impact Protection System (SIPS) airbag



*SIPS airbag decal **

SIPS airbag

As an enhancement to the structural Side Impact Protection System built into your car, your car is also equipped with Side Impact Protection System (SIPS) airbags. The SIPS airbag system consists of airbag modules built into the sides of both front seat backrests (1), cables (2) from these modules to the mechanical sensor units (3) and gas generators (4). The SIPS airbag system is designed to help increase occupant protection in the event of certain side impact collisions. The SIPS airbags are designed to deploy only during certain side-impact collisions, depending on the crash severity, angle, speed, and point of impact. The airbags are not designed to deploy in all side impact situations.

WARNING!

- The SIPS airbag system is a supplement to the Side Impact Protection System and the three-point seat belt system. It is not designed to deploy during collisions from the front or rear of the car or in rollover situations.
- The use of seat covers on the front seats may impede SIPS airbag deployment.
- No objects, accessory equipment or stickers may be placed on, attached to or installed near the SIPS airbag system or in the area affected by SIPS airbag deployment (see illustration to the right above).
- Never try to open or repair any components of the SIPS airbag system. This should only be done by an authorized Volvo service technician.
- For best protection from the SIPS airbag system, both front seat occupants should sit in an upright position with the seat belt properly fastened.

NOTE: SIPS airbag deployment (one airbag) occurs only on the side of the vehicle affected by the impact.



1 - Airbag, 2 - cable, 3 - sensor unit, 4 - gas generator

WARNING!

- Never drive with the airbags deployed. The fact that they hang out can impair the steering of your car. Other safety systems can also be damaged. The smoke and dust formed when the airbags are deployed can cause skin and eye irritation in the event of prolonged exposure.
- If your car has been subjected to flood conditions (e.g. soaked carpeting/standing water on the floor of the vehicle) or if your car has become flood-damaged in any way, do not attempt to start the vehicle or put the key in the ignition before disconnecting the battery. This may cause airbag deployment which could result in personal injury. Have the car towed to an authorized Volvo retailer for repairs.

pg. 9 Roll Over Protection System (ROPS)



Roll Over Protection System (ROPS)

- The ROPS system consists of two roll bars located behind the rear seat head restraints and a sensor which monitors the roll or pitch angle of the car. If the pitch angle exceeds approximately 72 degrees or the roll angle exceeds approximately 38 degrees, the sensor automatically deploys (raises) the roll bars.
- If the ROPS system has been deployed, an authorized Volvo retailer should inspect the system and make any necessary repairs/adjustments.
- No objects should be placed over the roll bars behind the rear seat head restraints.
- No one should be allowed to sit on the cover over the convertible top storage compartment.

WARNING! You should never perform any maintenance or in any way attempt to repair/adjust the ROPS system yourself.

pg. 10 Child safety

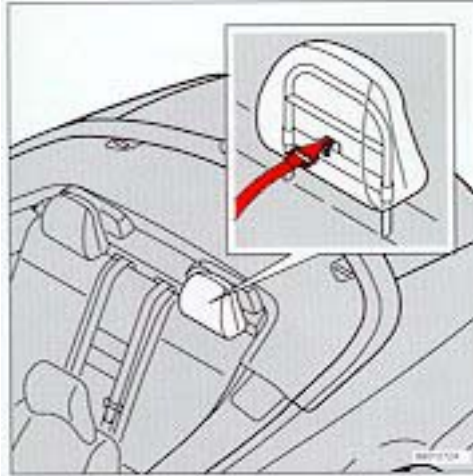

Child Restraint Anchorages

Volvo cars can be fitted with Child Restraint Top Tether Anchorages in the rear seat. There are two anchorage hooks under the rear head restraints.

Installing the top tether

Attach the strap from the child seat to child restraint anchorage hook under the rear head restraint.

Refer to the child seat manufacturer's instructions for securing the seat.

WARNING! Child Restraint Anchorages are designed to withstand only those loads imposed by correctly fitted Child Restraints. Under no circumstances are they to be used for adult seat belts or harnesses. The anchorages are not able to withstand excessive forces on them in the event of collision if full harness seat belts or adult seat belts are installed to them. An adult who uses a belt anchored in a Child Restraint Anchorage runs a great risk of suffering severe injuries should a collision occur.

WARNING! The rear seat of the Volvo C70 is intended for two occupants only. Only two three-point seat belts are provided. The center position should never be used to seat a passenger.

pg. 11 Child safety (cont.)

Keeping child seats in place (ALR/ELR*)

To make child seat installation easier, each seat belt (except for the driver's belt) is equipped with a locking mechanism to help keep the seat belt taut.

When attaching the seat belt to a child seat:

- Attach the seat belt to the child seat according to the child seat manufacturer's instructions.
- Pull the seat belt out as far as possible.
- Insert the seat belt latch plate into the buckle (lock) in the usual way.
- Release the seat belt and pull it taut around the child seat.

A sound from the seat belt retractor will be audible at this time and is normal.

The belt will now be locked in place.

This function is automatically disabled when the seat belt is unlocked and the belt is fully retracted.

* Automatic Locking Retractor/Emergency Locking Retractor

Important!

Why Volvo believes no child should sit in the front seat of a car.

It's quite simple really. A front air bag is a very powerful device designed, by law, to help protect an adult. Because of the size of the air bag and its speed of inflation, a child should never be placed in the front seat, even if he or she is properly belted or strapped into a child safety seat. Volvo has been an innovator in safety for over fifty years, and we'll continue to do our part. But we need your help. Please remember to put your children in the back seat, and buckle them up.

Volvo has some very specific recommendations:

- Always wear your seat belt.
- Air bags are a SUPPLEMENTAL safety device which when used in conjunction with a three-point seat belt can help reduce serious injuries during certain types of severe accidents. Please do not disconnect the air bag system in your vehicle.
- Volvo strongly recommends that ALL children sit in the rear seat of any vehicle and that they be properly restrained.
- A child should NEVER sit in the front passenger seat of any vehicle equipped with a front passenger side airbag.
- Volvo recommends that ALL occupants (adults and children) shorter than four feet seven inches (140 cm) be seated in the back seat of any vehicle with a front passenger side airbag.

Drive safely!

pg. 12 Child safety

Child safety

Volvo recommends the proper use of restraint systems for all occupants including children. Remember that, regardless of age and size, a child should always be properly restrained in a car.

Restraint systems for children are designed to be secured in the vehicle by lap belts or the lap portion of

a lap-shoulder belt. Such child restraint systems can help protect children in cars in the event of an accident only if they are used properly. However, children could be endangered in a crash if the child restraints are not properly secured in the vehicle. Failure to follow the installation instructions for your child restraint can result in your child striking the vehicle's interior in a sudden stop.

Holding a child in your arms is NOT a suitable substitute for a child restraint system. In an accident, a child held in a person's arms can be crushed

Chapter 2 - Instruments, switches and controls

pg. 14 Instruments, switches and controls

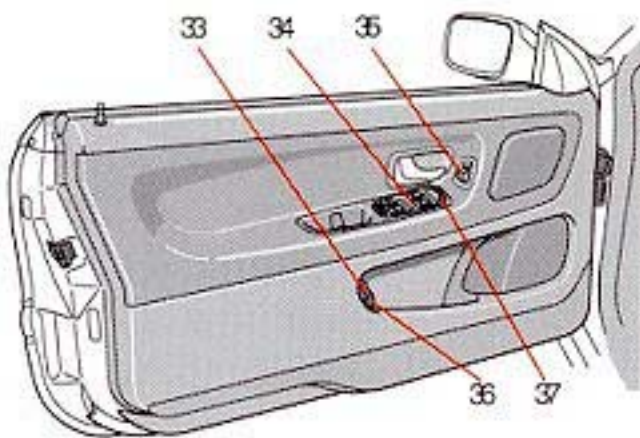
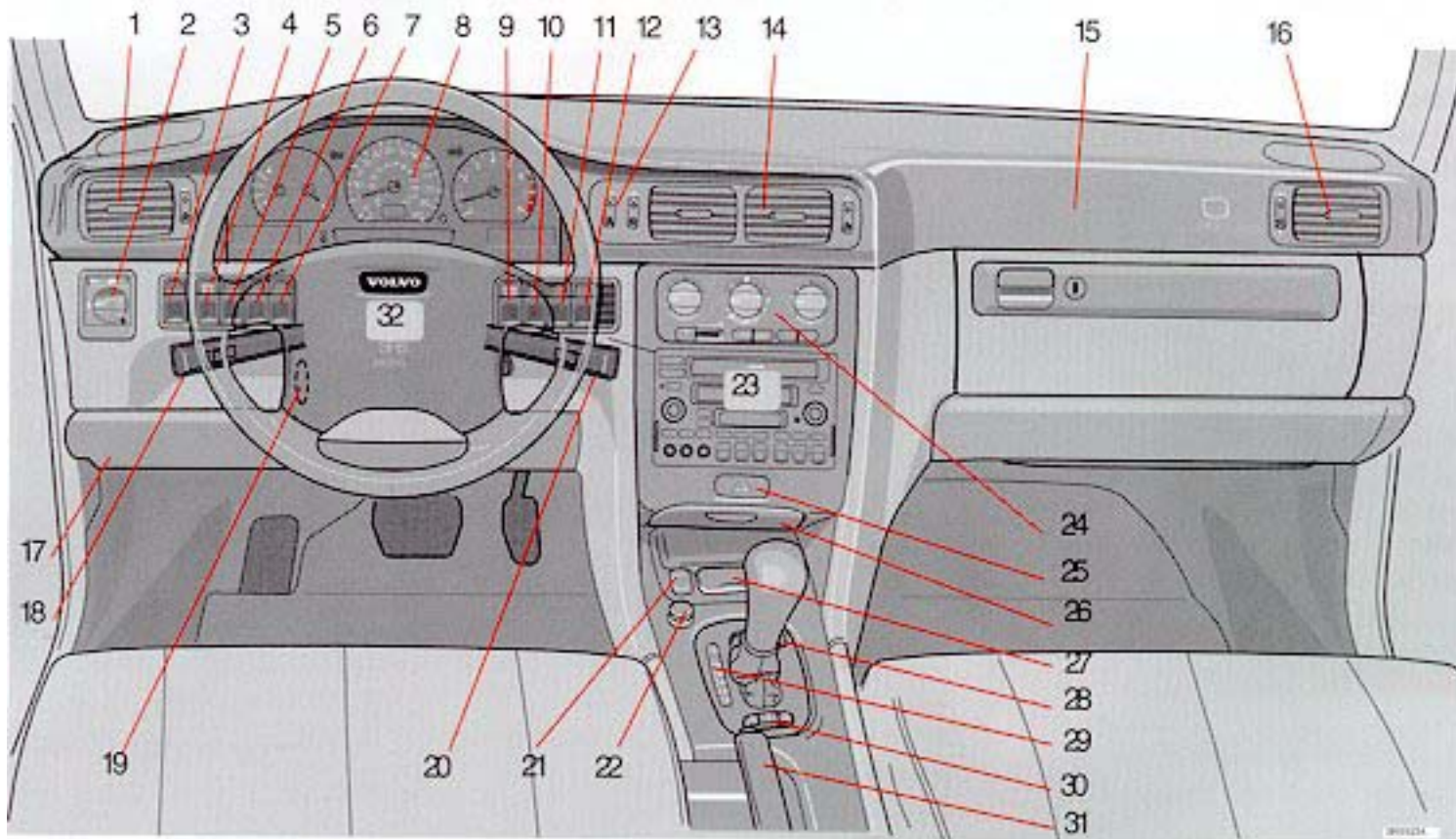

Page

- 1 [Air vents](#) 33
- 2 [Headlights, parking lights](#) 20
- 3 [Instrument illumination](#) 22
- 4 [Rear fog light](#) 22
- 5 [Front fog lights \(optional\)](#) 22

pg. 15 Instruments, switches and controls

Page

6	Space for additional equipment	
7	Space for additional equipment	
8	Instruments	14-15
9	Traction control system (optional)	23
10	Electrically operated convertible top	40-41
11	Trip computer (optional)	26-28
12	Rear window demister/heated door mirrors	23
13	Air mix	33
14	Air vents	33
15	Passenger side air bag (SRS) hatch	4-6
16	Air vents	33
17	Hood release	51
18	Turn signals, high/low beams	20
18	Cruise control	29
19	Adjustable steering wheel	32
20	Windshield wiper/washer	21
21	Heated front seats (optional)	30
22	Auxiliary socket	31
23	Audio systems	133
24	Heating and ventilation controls	33-35
25	Hazard warning flashers	23
26	Ashtray	31
27	Coin holder	55
28	Shiftlock release button (automatic transmission only)	99
29	Gear selector shift positions	62-63
30	Transmission mode selectors	64
31	Parking brake	30
32	Horn/SRS	4-6
33	Trunk open control	52
34	Power window controls	36
35	Power mirror controls	48
36	Fuel tank open control	37

Some of the items above are available on certain models only.

Shiftlock (automatic transmission only)

When your car is parked, the gear selector is locked in the (P)ark position. To release the selector from this position, turn the ignition key to position II (or start the engine), depress the brake pedal, press the button on the front side of the gear selector and move the selector from (P)ark.

If it is necessary to manually override the shiftlock system:

- Turn the starting (ignition) key to position I
- Press firmly on the "SHIFTLOCK OVERRIDE" button located near the base of the gear selector.
- While holding the override button down, press the button on the front of the gear selector.
- Move the gear selector from the (P)ark position.

Keylock (automatic transmission only)

This means that when you switch off the ignition, the gear selector must be in the (P)ark position before the starting (ignition) key can be removed from the ignition switch.

Anti-lock Brake System (ABS)

The ABS system in your car performs a self-diagnostic test when the vehicle first reaches the speed of approximately 12 mph (20 km/h). The brake pedal will pulsate several times and a sound may be audible from the ABS control module. This is normal.

Fuel tank cover

The fuel tank cover is locked and must be popped open using the control on the driver's door.

The pages in this section provide detailed descriptions of the vehicle's instruments and controls. Note that vehicles may be equipped differently, depending on special legal requirements.

pg. 16 Instruments

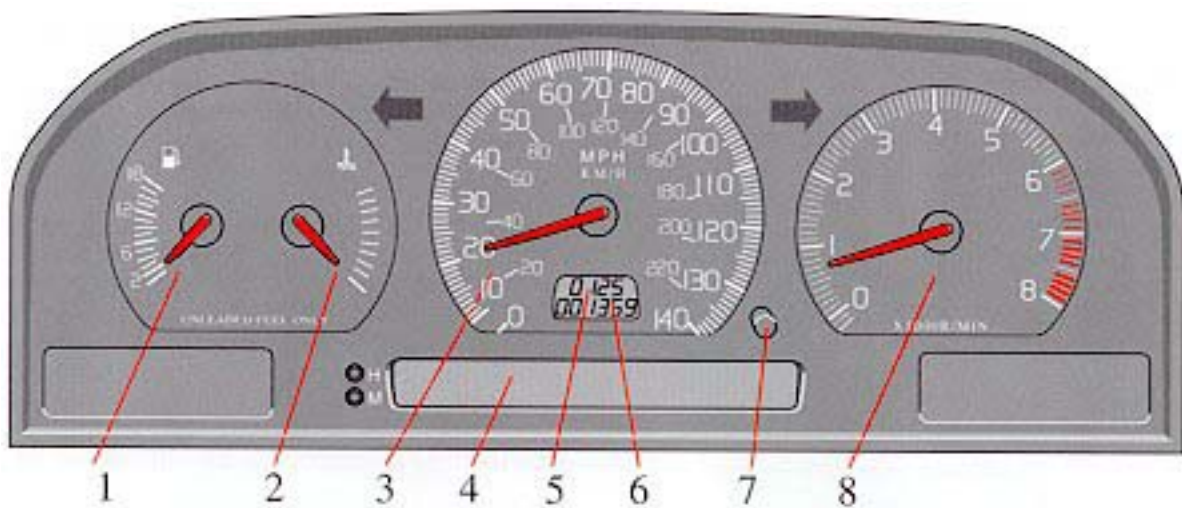

1 Fuel gauge

The fuel tank holds approximately 18.4 US gals. (70 liters). When the warning light comes on there is approximately 1.8 US gals. (8 liters) of fuel remaining. [See "Refueling" for further information.](#)

2 Temperature gauge

Do not drive the car with the pointer in the red range. The pointer should be approximately midway on the gauge face when driving. If the pointer approaches the red range repeatedly, check coolant level. [See page 130.](#)

3 Speedometer

4 Clock, ambient temperature sensor, trip computer (certain models)

5 Odometer

6 Trip odometer

Used for measuring shorter distances. The last digit indicates 1/10 mile/kilometer.

7 Trip odometer reset button

8 Tachometer

Reads thousands of engine rpm. The engine should not be operated in red range. **The highest permitted constant engine speed is 6,200 rpm.**



[Contents](#) | [Top of Page](#)

pg. 17 Indicator and warning lights



- | | | |
|---|--|---|
| 1. Turn signal, left | 9. Bulb failure warning sensor | 19. Low coolant level |
| 2. Turn signal, right | 10. (Not in use) | 20. Traction control system (option) |
| 3. ROPS indicator lamp | 11. (Not in use) | 21. Malfunction indicator lamp (See page 18 for more information) |
| 4. Low washer fluid level
If the lamp glows continuously when the engine is running, there is only about 1/2 -1 US qt. remaining in the washer fluid reservoir. | 12. SRS indicator lamp | 22. Service reminder indicator |
| 5. Low fuel level
When the lamp glows, only about 1.8 US gals. (8 liters) of fuel remain. If the ignition is switched on while refuelling, the gauge may read inaccurately for up to 25 minutes. | 13. Generator not charging | |
| 6. Rear fog light | 14. Low engine oil pressure | |
| 7. High beams | 15. Brake warning light | |
| 8. Trunk/tailgate open | 16. Parking brake applied | |
| | 17. ABS system | |
| | 18. Transmission mode "W" or gear positions 3 or L engaged (automatic transmissions) | |

pg. 18 Warning lights

The warning lights described on pages 18 and 19 should never stay on when driving
When the ignition key is turned on, and before the engine starts, all of the warning lights should be on to test the function of the bulbs. Should a light not go off after the engine has started, the system indicated

should be inspected. However, the parking brake reminder light will not go off until the parking brake is fully released.



Generator warning light

If the light comes on while the engine is running, have the charging system checked.



Malfunction indicator lamp

If the lamp comes on (or stays on after the vehicle has started), the engine diagnostic system has detected a possible fault in the emission control system. Although driveability may not be affected, see an authorized Volvo retailer as soon as possible for inspection.

NOTE: If the fuel filler cap is not closed tightly or if the engine is running when the car is refueled, the Malfunction Indicator Lamp may indicate a fault. Use only Volvo original or approved fuel filler caps.



Oil pressure warning light

If the light comes on while driving, stop the car and then stop the engine immediately and check the engine oil level. [See page 116](#). If the light stays on after restart, have the car towed to the nearest authorized Volvo retailer. After hard driving, the light may come on occasionally when the engine is idling. This is normal, provided it goes off when the engine speed is increased.



Parking brake reminder light

This light will be on when the parking brake (hand brake) is applied. The parking brake lever is situated between the front seats. Canadian models are equipped with this warning light: 

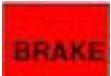

Brake failure warning light

If the light comes on while driving or braking, stop immediately, open the hood and check the brake fluid level in the reservoir. [See page 123 for reservoir position](#).

Canadian models are equipped with this warning light: 

WARNING! If the fluid level is below the MIN mark in either section of the reservoir: DO NOT DRIVE. Tow the car to a Volvo retailer and have the brake system checked and any leakage repaired.

pg. 19 Warning lights (cont.)



TRACS disengaged (option)

If the TRACS (TRAction Control System) is manually disengaged with the switch on the dashboard, the warning light will come on. This will also come on to indicate a TRACS malfunction, and when the brakes overheat, although it goes out again at the normal temperature level. **If the lamp remains on, the system should be checked by an authorized Volvo retailer.** This lamp should not be confused with the ON/OFF indicator lamp above the switch. [See page 23 for additional information.](#)



Anti-lock Brake System (ABS)

If the warning lamp lights up there is a malfunction of the ABS system (the standard braking system will however function). The vehicle should be driven to a Volvo retailer for inspection.

[See page 72 for additional information.](#)

Canadian models are equipped with this warning light:



Coolant level sensor

If the light comes on while driving, the coolant level is low. The coolant level in the expansion tank should be checked immediately and topped up if necessary. The cooling system should be inspected by an authorized Volvo retailer.



Mode "W" engaged

The lamp will light up when the Winter/Wet starting mode is engaged or if gears "3" or "L" are selected. If the warning lamp begins to **flash**, this means that there is a fault in the automatic gearbox. Contact your Volvo retailer.



Supplemental Restraint System (SRS)

If the light comes on (or stays on after the vehicle has started), the SRS diagnostic system has detected a fault. Drive to an authorized Volvo retailer for an inspection of the system. See the SRS section for more information.



Service reminder indicator

This light will come on at 10,000 mile (16,000 km) intervals*, after 750 hours of driving or after 12 months, whichever occurs first. It is a reminder to the driver that the service interval has been exceeded. The light will stay on for 2 minutes after the start until reset by the servicing retailer.



Bulb failure warning light

The light will come on if any of the following bulbs are defective:

- one of the low beam headlights
- one of the tail lights
- one of the brake lights when the brake pedal is depressed.

Check the fuse and bulb. See sections ["Replacing bulbs"](#) and ["fuses"](#).

Should the warning light come on after a defective outside bulb has been replaced, the corresponding bulb on the other side of the car should also be replaced.



Roll Over Protection System (ROPS)

If the warning lamp remains on after the engine has started or comes on while you are driving, the ROPS self-diagnostic system has detected a fault. The car should be driven to an authorized Volvo retailer as soon as possible for inspection.

[Please refer to page 9 for more information on the ROPS system.](#)



[Contents](#) | [Top of Page](#)

Headlights and parking lights



O All lights off *

☛ Parking lights on **

☛ Headlights and parking lights are on if starting (ignition) switch is in positions I or II.

If the headlight switch is in position ☛ all lights will go out when starting switch is switched off.

With the headlight switch in position ☛ the parking lights will stay on (headlights off) with the daytime running light screw (A) in position ①

The high beams can only be switched on if the headlight switch is in position ☛.

Switch from high to low beams and vice versa by moving the turn signal switch lever on the left side of the steering column towards the steering wheel.

* Models equipped with daytime running lights: The low beams, tail lights, parking lights and license plate lights will come on automatically when the ignition is switched on.

** The daytime running lights will also function when the headlight switch is in position ☛ and the daytime running light screw (A) is in position ②.

[For additional information on the daytime running lights, see page 24.](#)

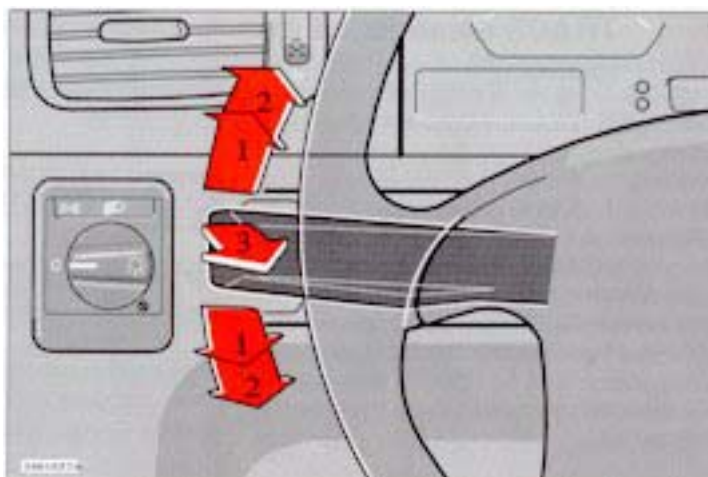

Turn signals

1 Lane change position. In maneuvers such as lane changing, the driver can flash the turn signals by moving the turn signal lever to the first stop and holding it there. The lever will return to the neutral position when released.

2 Signal lever engaged for normal turns

3 High beam/low beam switch (headlights on)

Move the lever towards the steering wheel and release it.

Headlight flasher (headlights off)

Move the lever towards the steering wheel. The headlight high beam will be on until the lever is released.

NOTE: A defective turn signal bulb will cause the turn signal indicator and remaining signal lights to flash more rapidly than normal.

pg. 21 Windshield wipers/washers, Ignition switch

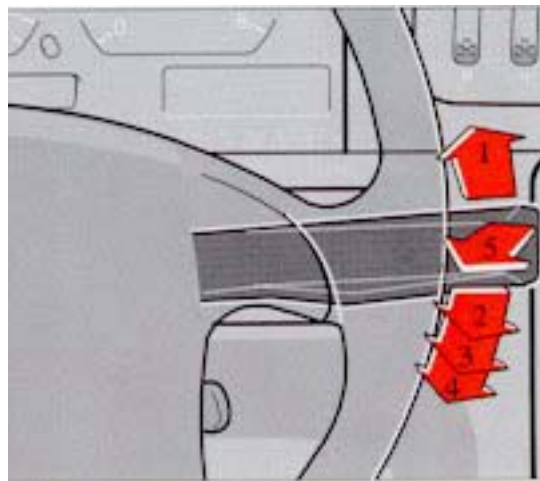

Windshield wipers/washers

1 Intermittent wiper

With switch in this position, the wipers will sweep approximately every seventh second.

2 "Single sweep" position.

The switch returns automatically when released

3 Wipers, normal speed.

4 Wipers, high speed

5 Windshield wiper/washer, headlight wiper/washer (certain models)

The wiper will make 2-3 complete sweeps across the windshield and headlights after the lever is released.

O Locked position:

Remove the key to lock the steering wheel*

WARNING! Never turn the key to position O while driving or when the car is being towed.

I Intermediate position:

Certain accessories, radio, etc. on, daytime running lights off.

II Drive position:

Key position when engine is running.

III Starting position:

Release the key when the engine starts. The key returns automatically to the Drive position.

* On cars equipped with an automatic transmission the gear selector must also be in the (P)ark position.

Starting (ignition) switch/steering wheel lock

The steering wheel lock might be under tension when the car is parked. Turn the steering wheel slightly to free the ignition key.

In order to reduce car theft, make sure the steering wheel lock is engaged before leaving the car.

A chime will sound if the starting key is left in the ignition lock and the front door on the driver's side is opened.

pg. 22 Instrument illumination, Fog lights

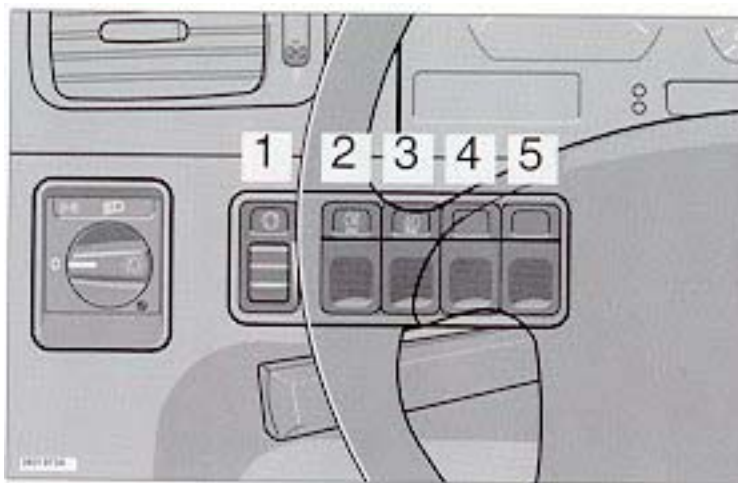
**1 - Instrument illumination**

To increase the brightness: move the thumbwheel up.

To decrease the brightness: move the thumbwheel down.

2 - Rear fog light*

The rear fog light (located in the driver's side tail light cluster) is considerably brighter than the normal tail lights and should be used only when the atmospheric conditions, such as fog, rain, snow, smoke or dust reduce the daytime or nighttime visibility of other vehicles to less than 500 ft (150 meters).

For the rear fog light to function, the low beam headlights must be switched on.

* By design, there is one rear fog light only, located in the driver's side tail light cluster.

3 - Front fog lights (option)

The front fog lights, located in the front spoiler, will only function in combination with the low beam headlights.

4 - Space for optional equipment

5 - Space for optional equipment



[Contents](#) | [Top of Page](#)

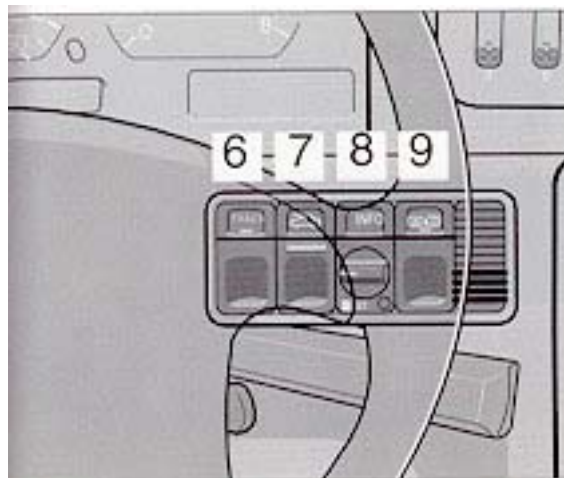

6 - TRAction Control System (TRACS) - option

TRACS is a system designed as an aid when starting/driving off if one of the drive wheels has poor traction due to weather conditions or the road surface and is connected to the ABS control module. TRACS engages automatically at speeds below 25 mph (40 km/h) when one of the drive wheels loses traction. It disengages automatically when speed exceeds 25 mph (40 km/h). The sound which can be heard when the system is operating comes from the ABS system.

TRACS can be disengaged manually using the switch on the dashboard. The indicator light will come on.

7 - Electrically operated convertible top

Please see page 40 for operating instructions.

NOTE: For information on manually raising the convertible top, please see page 100.

8 - Trip computer - option

Turn the dial to the desired function. [For more information, see pages 26-28.](#)

9 - Rear window demister, heated side-view mirrors

Press the switch to start heating the rear window and side-view mirrors. The control light in the switch will illuminate.

A timer switches off the system after approximately 12 minutes. The control light will go out correspondingly.

Hazard warning flashers

The four-way flasher (located above the ashtray) should be used to indicate that the vehicle has become a traffic hazard.

NOTE: Regulations regarding the use of the hazard warning flasher may vary from state to state.



pg. 24 Daytime running lights

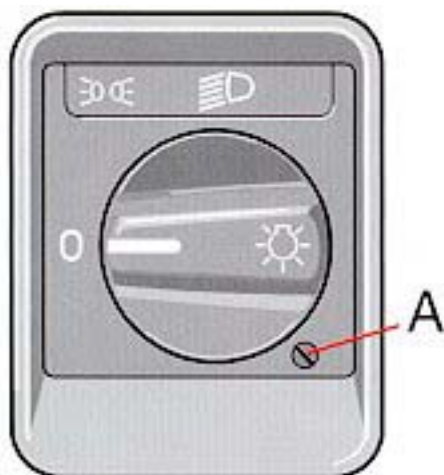

Automatic daytime running lights

Screw **A** in the illustration (available on U.S. models only) is used to control the automatic daytime running lights when the headlight switch is in position 0.

To adjust, press in the screw with a small screwdriver and turn to one of the following positions:

- ☉ **Automatic daytime running lights**
- ⊗ **Automatic daytime running lights**

The daytime running lights will also function when the headlight switch is in position ☉ and switch **A** is in this position.

- ⊗ **All lights off** (daytime running light function disabled)

NOTE: The daytime running light function may only be disabled (turned off) in the U.S. - Canadian law mandates the use of daytime running lights.

pg. 25 Clock, Ambient temperature sensor (certain models)



Resetting the clock

The digital clock can be reset by pressing one of the two buttons (A and B) with a pointed object such as the tip of a pen.

h = hours

m = minutes

Maintain the pressure on the buttons for more than four seconds to change the time more quickly.

Ambient temperature sensor

This sensor indicates the temperature slightly above the road surface and represents air temperature where road icing may occur. An amber warning lamp (C) lights up when the temperature is in the range of 23 - 36° F (-5 - +2° C). **Please note that this lamp does not indicate a fault with your car.**

At low speeds or when the car is not moving, the temperature readings may be slightly higher than the actual ambient temperature due to the heat generated by the engine.

Display alternatives

If buttons A and B are pressed down simultaneously, it is possible to shift between four different display alternatives:

Press 1st time: 12 hour clock and °F

Press 2nd time: 24 hour clock and °F

Press 3rd time: 12 hour clock and °C

Press 4th time: 24 hour clock and °C



[Contents](#) | [Top of Page](#)

pg. 26 Trip computer (certain models)

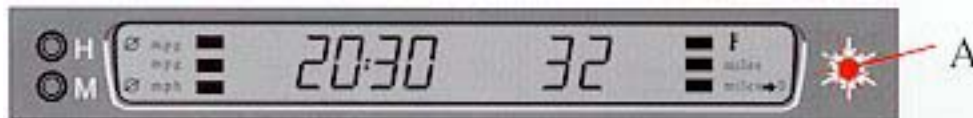

Trip computer

The trip computer offers six functions which are presented in a single display. The cursor indicates the selected function. The trip computer's clock is shown permanently in the left-hand field. Refer to the previous page for more detailed information regarding the clock function.

The following data is monitored by the computer:

- Average speed
- Current fuel consumption
- Average fuel consumption
- Ambient temperature*
- Tripmeter
- Driving distance on current fuel reserve

* Warning light A in the illustration above. [See page 28 for more details.](#)

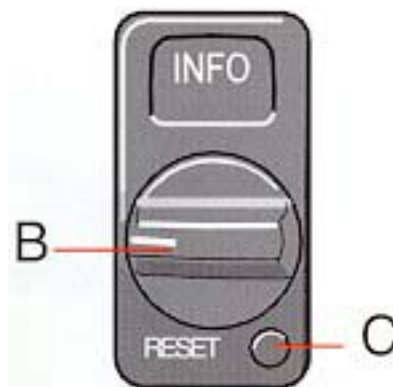

Trip computer controls

Select one of the trip computer's six functions by using control B. The Reset button (C) is used to reset the following functions:

- Average speed
- Average fuel consumption
- Trip meter

Rotate the control to the required position and press the button for at least two seconds to reset the selected function.

NOTE: If pressure is maintained on the button for another three seconds, all three of the functions mentioned above will be reset.

pg. 27 Trip computer (certain models) (cont.)

Average speed Ø mph (Canada: km/h)

Average speed since the function was last reset. When the ignition is switched off, the average speed is stored in memory and is used as the basis for the new figure when the engine is started again. It can be reset by pressing the reset button on the trip computer control.



Current fuel consumption mpg (Canada: L/100 km)

Continuous information on current fuel consumption, calculated once per second. When the car is not moving, the display shows "----".



Average fuel consumption Ø mpg (Canada: L/100 km)

Average fuel consumption since the function was last reset. When the ignition is switched off, the average fuel consumption figure is stored in memory and remains in memory until it is reset using the button on the trip computer control.



pg. 28 Trip computer (certain models) (cont.)

Ambient temperature

Shows the ambient temperature just above the road surface while driving. When the temperature is in the range 23 - 36° F (-5 - +2° C), the ambient temperature sensor activates an indicator light in the "snowflake" symbol to help alert the driver of possible slippery driving conditions. **Please note that this lamp does not indicate a fault with your car.**

At low speeds or when the car is not moving, the temperature readings may be slightly higher than the actual ambient temperature due to the heat generated by the engine.



Tripmeter in miles (Canada: km)

Shows the distance driven since the function was last reset. This value is stored in memory until it is reset using the reset button on the trip computer control.



Driving distance on current fuel reserve mile - 0 (Canada: km)

Shows the distance which can be driven on the fuel remaining in the tank, calculated on the basis of the average fuel consumption and the amount of fuel remaining in the tank at the time of the reading.

When the quantity of fuel drops to below approximately 1.8 US gals. (8 liters), a warning light in the instrument panel comes on. When the driving distance on the current fuel reserve is less than 5 miles (8 km), the display shows "—".



[Contents](#) | [Top of Page](#)

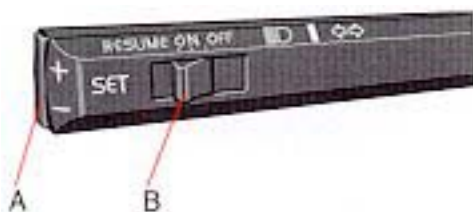

Cruise control

The cruise control switches are located on the turn signal lever.

To engage and set the desired speed:

1. Set switch (B) to ON.
2. Accelerate to the desired cruise speed.
3. Press the + or - area of the SET button (A) to set the desired speed.

NOTE: The cruise control cannot be engaged at speeds below 22 mph (35 km).

Braking

This will automatically disengage the cruise control. The previously selected cruise speed is retained in the memory and by momentarily setting the switch to RESUME position, that speed will be re-engaged. If the cruise control is already engaged, the cruising speed can be increased or decreased by depressing the SET button (A) towards either + or -. One short press on the button corresponds to a speed change of approx. 1 mph (1.6 km/h). When the button is released, the vehicle will maintain the current speed. If actual speed falls below 70% of the set speed or if the wheels spin or lock, the cruise control will disengage automatically.

NOTE: (AUTOMATIC TRANSMISSION)

When driving up steep hills with the cruise control engaged, the transmission may shift intermittently. This can be avoided by switching between transmission modes **E** or **S** while on the hill. Normally, the (**E**)conomy mode should be used when the cruise control is engaged.

Acceleration

Momentary acceleration, such as for passing, does not interrupt cruise control operation. The previously selected speed will be maintained without having to set the switch to RESUME.

To disengage the cruise control system:

Set switch (B) to OFF, depress the brake pedal or move the gear selector to position N. Switching off the starting (ignition) switch will automatically disengage the cruise control system. On cars equipped with manual transmissions, the cruise control can also be disengaged by depressing the clutch.

WARNING! The cruise control should not be used in heavy traffic or when driving on wet or slippery roads. Do not use or resume cruise control in reverse gear.

NOTE: When the ignition is switched off, any information stored in the cruise control memory is erased.

pg. 30 Heated front seats (certain models), Parking brake



Heated front seats

The heated front seats can be switched on and off as required. When switched on, the system senses the ambient temperature and regulates the level of heat applied. When the optimum temperature is reached, the heating switches off automatically. While driving, the seat heating for the passenger seat should be switched off when the seat is not occupied.

NOTE: The passenger seat heater will not function if the seat is not occupied.



Parking brake lever

Parking brake (hand brake)

The lever is situated between the front seats.

The brake is applied to the rear wheels.

WARNING! Always use the parking brake (hand brake) when parking. On hills, also turn the front wheels toward the curb.

pg. 31 Auxiliary socket, Ashtrays

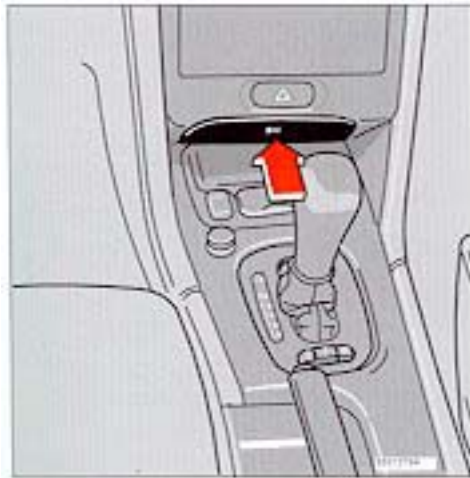

Ashtray

Front ashtray

To **open** the front ashtray, press lightly on the panel.

To **empty** the front ashtray:

- Put the gear selector (aut. transmission) in position L. To release the gear selector from the (P)ark position, the ignition key must be in position II and the brake pedal must be depressed.
- Grasp the front edge of the ashtray and pull it straight out.

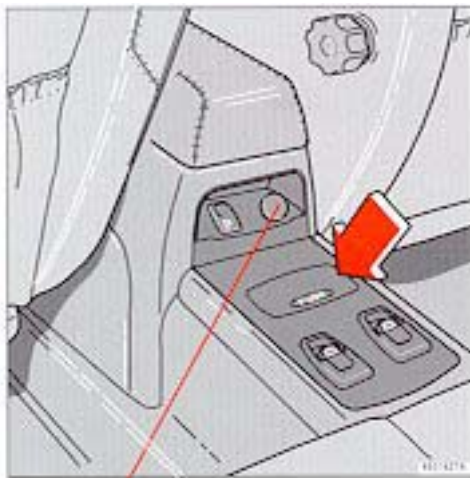

Rear seat auxiliary socket and ashtray*

Rear ashtrays

To **open** the rear ash tray, pull it straight out.

To **empty** the rear ash tray, pull it out, lift up the rear edge and remove.



*Auxiliary socket**

Auxiliary socket

This 12 volt socket can be used to plug in certain accessories such as cellular telephones, etc.

NOTE: The "OBD II" terminal, a connector for diagnostic equipment, is located under the cover of the storage compartment between the front seats. This terminal is intended for use by authorized service technicians only.

* The auxiliary sockets can also be used as cigarette lighters.

The key must be in position I (or higher) for the auxiliary socket to function.

pg. 32 Steering wheel adjustment

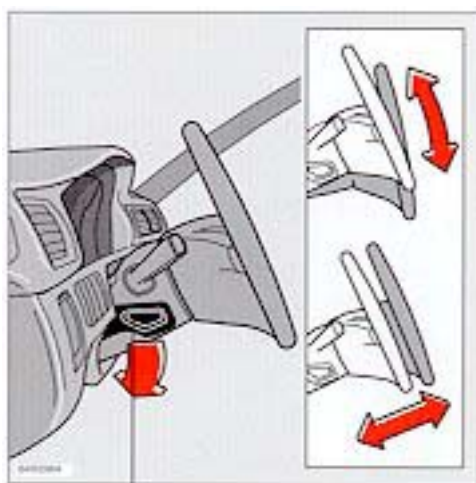

Pull down...

Steering wheel adjustment

Both the height and the reach of the steering wheel can be adjusted to a comfortable position for the driver. Pull down the lever on the left of the steering column. Adjust the steering wheel to a suitable position and press the lever back into place to lock the steering wheel in the new position. Check that the steering wheel is locked in the new position.

WARNING! Never adjust the steering wheel while driving.



[Contents](#) | [Top of Page](#)

pg. 33 Heating, ventilation and air conditioning

Airmix Vent - open (A)/closed (B)

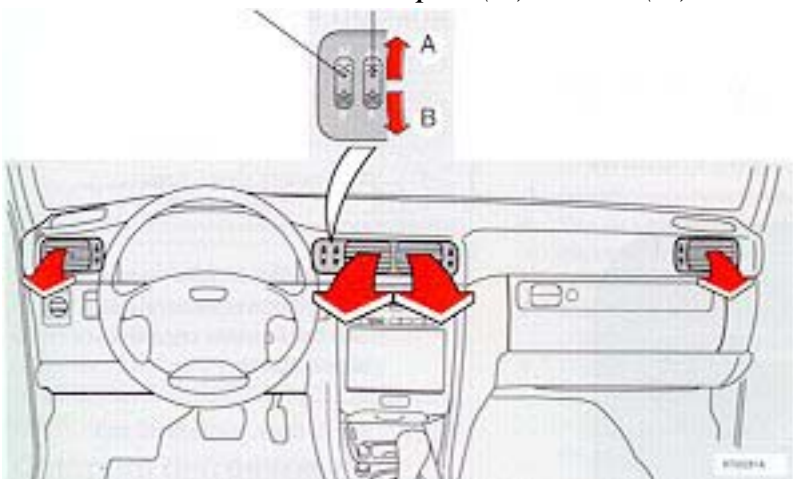

Heating and air conditioning

Your Volvo is equipped with a heating system combined with air conditioning. Depending on which function you select, warm or cool/cold air is distributed to the different parts of the passenger compartment. A slight amount of condensation may be emitted from the air vents when the air conditioning is initially switched on. This can occur when both humidity and ambient temperature are high and is normal.

Air mix (fresh air)

The center panel vents have an air mix function which allows fresh air to enter the passenger compartment when the vents are open (position B). This function is designed to allow you to direct cool air toward your face while directing warmer air to the rest of the passenger compartment.

To warm/cool the compartment as quickly as possible, the air mix control should be in the closed position.

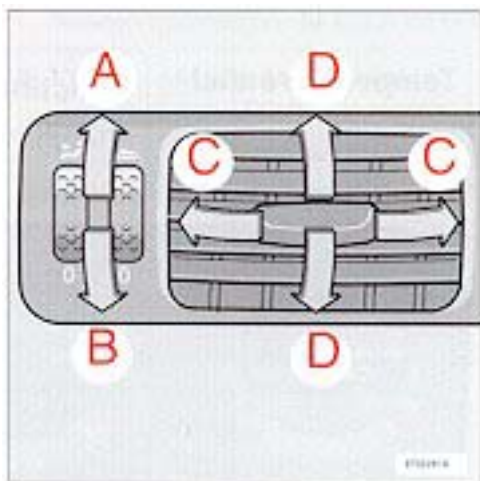

*A- open, B- closed, C- horizontal flow,
D- vertical air flow.*

Cabin air filter

The ventilation system utilizes a cabin air filter which helps prevent pollen and dust from entering the passenger compartment through the air vents.

Refrigerant

Volvo cares about the environment. The air conditioning system in your car contains a CFC-free refrigerant - R134a. This substance will not deplete the ozone layer. The system contains 1.65 lbs (0.75 kg) R134a and uses ZXL 100PG (type PAG) oil.

NOTE: All maintenance on the climate control systems should be carried out by an authorized Volvo service technician only.

pg. 34 Heating, ventilation and air conditioning (Electronic Climate Control)

Temperature dial

Driver's side
Set desired
temperature

Function selector

Set for desired air flow

Temperature dial

Passenger's side
Set desired
temperature

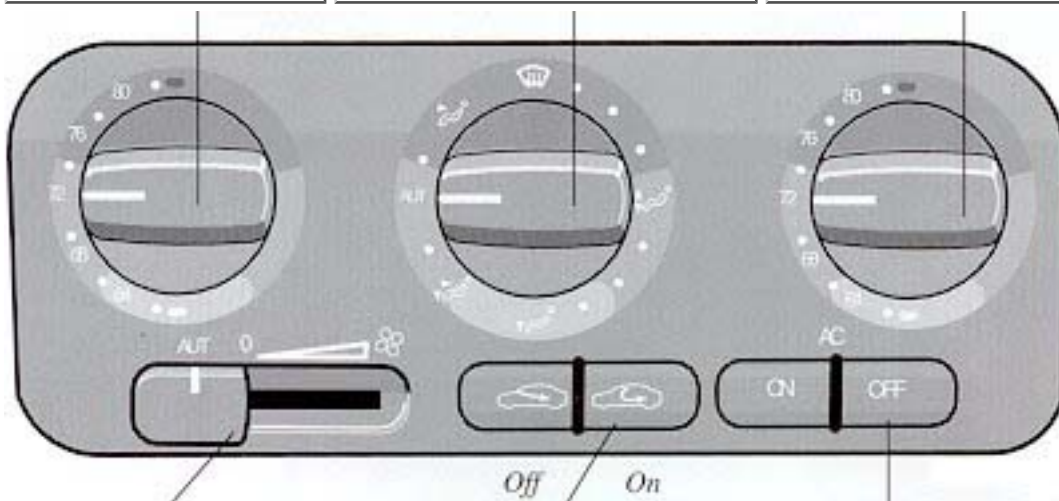

BLOWER

AUT=Blower speed automatically regulated.
0=OFF
Move the knob to the right to increase blower speed.

RECIRCULATION

Air in the passenger compartment recirculates (no fresh air enters the car). The amber light in the right-hand button is ON when the function is engaged. It should not be used for more than 15 minutes*. The green light in the left-hand button indicates that outside air can enter the passenger compartment.

AC ON/OFF

The lights in the buttons indicate if the A/C is off or on**.

** When the function selector is in the defrost setting, the A/C system is always ON and the blower will function at its highest speed if it is in the AUT position.

Function selector

AUT Air distribution automatically regulated.

 Air through panel vents

 Defrost. Air to windshield and side windows.

 Air to floor, windshield and side windows.

 Air through floor vents.

 Bi-level. Air through floor and panel vents.

* Pressing the On section of the butto for more than three seconds activates a **timer function**. Recirculation will then always operate for 5 minute periods, after which the button will flash to indicate that recirculation has automatically switched off. Pressing the OFF button at any time during the 5 minute period will allow fresh air into the passenger compartment. Press the ON button again for more than 3 seconds to return the button to its original function (i.e., Recirculation will remain on until the OFF button is pressed).

pg. 35 Heating, ventilation and air conditioning (Electronic Climate Control) (cont.)

Automatic Setting

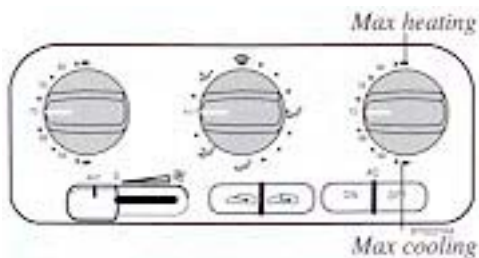

Set the function selector and blower control to AUT and select the desired temperature. If the driver's side temperature selector is set to either the max heating or max cooling position, the blower will run at its maximum speed.

Optimum defrosting

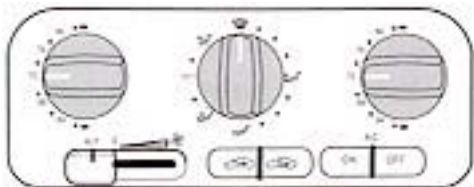

Set the function selector to  and move the blower control to the position AUT (as far to the left as possible). The A/C system will be on at this time even if the AC OFF button is depressed and the blower will run at its maximum speed. When the windows have cleared, set the function selector in the AUT position.

Additional information

- The air conditioning system will function best if it is always left on.
- Always keep the air intake grille at the base of the windshield under the rear edge of the hood free of snow.
- Water under the vehicle in hot weather can be the result of condensation from the air conditioning system and is quite normal.
- The air conditioning is disengaged when the blower is set at 0 and the speed of the vehicle is less than 20 mph (30 km/h).
- The air conditioning system functions only at temperatures above 32 F (0 C).
- **RECIRCULATION:** Use this function if the outside air is contaminated with exhaust gases, smoke, etc or to heat/cool the car quickly. When Recirculation is activated, very little air is drawn into the passenger compartment from the outside. *If your windows begin to fog or mist, check that the recirculation function is NOT engaged.*

NOTE: To help maintain stable passenger compartment temperature when driving with the sun roof or windows open, place the blower control in position "O" and adjust the desired temperature manually.

- If the panel vents are open, a certain amount of air will always flow through, regardless of the position the function dial is in. To increase the flow of air to either the floor or the windows, close the panel vents and open the outer vents.
- The panel vents may emit some condensation when the air conditioning is initially switched on and is quite normal.

This may occur if the ambient temperature and humidity are high.

- The sunlight sensor (located at the top center of the dashboard) should not be covered in any way as

this could cause incorrect information to be sent to the ECC system.

- The air conditioning is momentarily disengaged during full-throttle acceleration.

Difficult weather conditions

When driving in very humid conditions, heavy rain, sleet, etc., it may be better to use the manual rather than the automatic setting to defrost the windows. Set the mode selector to "Defrost"  or "Defrost/floor" and the fan speed to mid-range. Also shut the center air vents.

Faults in the ECC system

The RECIRCULATION ON and AC OFF lights will flash for approximately 20 seconds if a fault is detected in the ECC system. If this flashing recurs the next time the system is switched on, the climate control unit should be checked by an authorized Volvo retailer.



[Contents](#) | [Top of Page](#)

pg. 36 Electrically-operated windows

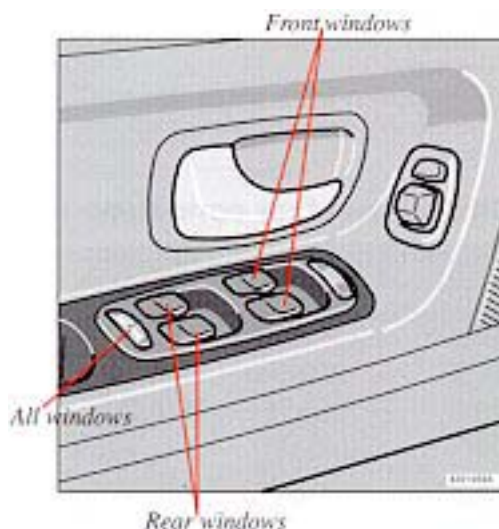

Electrically-operated windows

The electrically-operated windows are controlled by switches in the driver's door armrest. The starting (ignition) switch must be ON (intermediate position I) for the electrically-operated windows to function.

To lower: press down on the front edge of the button.

To raise: pull up on the front edge of the button.

Auto-down function - driver's window: The window can be *opened* automatically by pressing the front part of the button quickly and **releasing** it immediately. The window can be stopped by pressing the button again. If the button is held down, the window will be lowered until the button is released.

NOTE:

- When the convertible top is raised/lowered, all windows are automatically lowered slightly. When the top is completely raised/lowered, the windows will return to their original position.
- The power windows have an overload circuit breaker which is activated when an object blocks a window. Should this occur, remove the object and wait 20 seconds for the circuit breaker to reset. The power windows should then function.

WARNING! Make sure that children's hands are clear before raising the windows.

Cut-off function - rear windows

To prevent the rear windows from being opened with the buttons in the rear seat, pull up on the front edges of both rear window buttons on the driver's door quickly and release them. An indicator lamp near the buttons will light up to remind the driver that the rear seat window buttons are disabled and cannot

be used to open the rear windows. Repeat this procedure (the indicator lamp will go out) to make it possible to open and close the rear windows using the buttons in the rear seat.

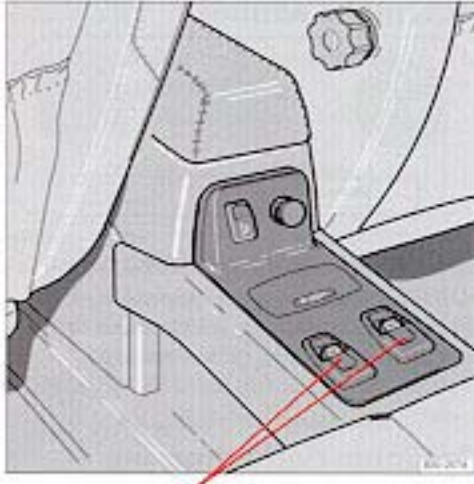

Window control buttons in rear console

"All Windows" button

This button can be used to raise/lower all windows at the same time.

To lower: press the right side of the button.

To raise: press the left side of the button.

Auto-down function: The windows can be *opened* automatically by pressing the right part of the button quickly and **releasing** it immediately. The windows can be stopped at any time by pressing the button again.

pg. 37 Rear speakers, Central locking button, Fuel tank cover



Button for optional rear speakers

Speakers behind rear seat backrest (option)

This button is used to turn the optional speakers behind the rear seat backrest on or off.



Central locking button

Central locking button

Press the switch to lock/unlock the doors and the trunk.

Lock: Press the left side of the button

Unlock: Press the right side of the button

NOTE: To help prevent accidentally locking the keys in the car, the central locking system is designed to unlock the doors immediately if the key is left in the ignition switch and the car is locked using the lock button on the door. **A sound from the lock will be audible at this time.**

Please note that this function will not unlock the doors if the engine is running.



Opening the fuel tank cover

The fuel tank cover is locked and must be popped open using the control on the driver's door. Pull the control button towards you to release the fuel tank cover.

[See page 99 for instructions on manually opening the fuel tank cover.](#)



[Contents](#) | [Top of Page](#)

Chapter 3 - Body and interior

pg. 39 Body and interior

Body and interior

The seats, convertible top, mirrors, etc. are described on the following pages.

[Convertible top](#) [40](#)

[Wind deflector](#) [41](#)

[Keys, doors and locks](#) [42](#)

[Remote keyless entry system](#) [43](#)

[Alarm](#) [44](#)

[Front seats](#) [46](#)

[Rear/side view mirrors](#) [48](#)

[Interior lights, Vanity mirrors](#) [49](#)

[Long load storage](#) [50](#)

[Hood](#) [51](#)

[Opening the trunk](#) [52](#)

[Trunk light, Spare tire, Jack](#) [53](#)

[Securing cargo, Avoiding battery drain](#) [54](#)

[Storage compartments](#) [55](#)

pg. 40 Electrically operated convertible top



Electrically operated convertible top



"All windows" control button

Electrically operated convertible top

To lower the convertible top:

- Start the engine. **The car must be at a standstill and the parking brake must be ON when raising/lowering the convertible top.** The gear selector must be in position P (automatic transmission) or in neutral (manual transmission).
- Press and hold down the lower section of the control switch (an indicator lamp will light up and all four windows will automatically be lowered slightly) until the convertible top is completely lowered. A chime will indicate when the top is completely down and properly in place in the storage compartment. The windows can then be raised/lowered with the "All windows" button on the driver's door.

To raise the convertible top:

- Press and hold down the upper section of the control switch until the convertible top is completely raised. A chime will indicate when the top is properly in position. Check that the cover over the convertible top storage compartment closes completely.

Movement of the convertible top can be stopped at any time by releasing the control switch.

WARNING!

- The convertible top must not be obstructed in any way when it is being raised or lowered.
- The rear seat should not be occupied while the convertible top is being raised or lowered.
- Anyone near the car should be well clear of the convertible top's moving parts before it is raised or lowered.
- Children should never be allowed to play with the convertible top control switch.

NOTE:

- The electrically operated convertible top has an overload protecting circuit breaker that is activated when an object blocks the top when it is in motion. If this occurs, remove the object and wait 20 seconds for the circuit breaker to reset before trying to raise/lower the top again. **See [page 100](#) for fault tracing information and instructions on manually raising the convertible top.**
- The trunk cannot be opened and the power windows/power antenna cannot be operated while the convertible top is being raised/lowered.

pg. 41 Electrically operated convertible top, Wind deflector

CAUTION:

- Be sure there is sufficient clearance above the car before raising/lowering the convertible top.
- Volvo recommends that you raise the convertible top and close the windows when you leave the car to help deter thefts and to protect the interior from rain, windblown dust, etc.
- No objects should be placed in the convertible top storage compartment. This could damage the convertible top mechanism.
- Roof racks may not be attached to or placed on the convertible top. See [page 67](#) for information on trunk-mounted luggage racks.
- Ice scrapers should not be used to remove snow from the convertible top.
- Do not lower the convertible top if it is frozen. The top should not be raised/lowered if the temperature is below 32° F (0° C).
- The top should be completely dry before it is lowered and stored in the storage compartment to help prevent damage from mildew.

See [page 105](#) for information on cleaning the convertible top.

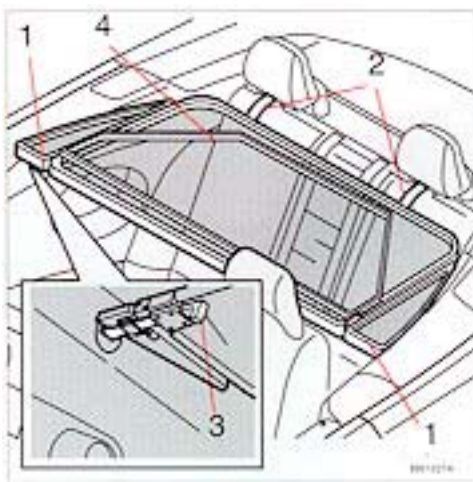

Wind deflector (option)

Installing the wind deflector:

- Fold out the panels on the sides of the wind deflector (1).
- Slide the two metal slats on the wind deflector under the rear seat head restraints (2). Slide them carefully to avoid damaging the upholstery.
- Press the catches (3) into the holes provided in the side panel until they click into place.
- Raise the wind deflector (4) 90°.

NOTE: The panels on the sides of the wind deflector can be folded under so that the deflector can be stored in the trunk. The catches (3) must be pushed in (toward the center of the car) before the panels can be folded.

WARNING! The wind deflector must be securely attached to help avoid injury to the occupants of the car or other motorists.

pg. 42 Keys, doors and locks

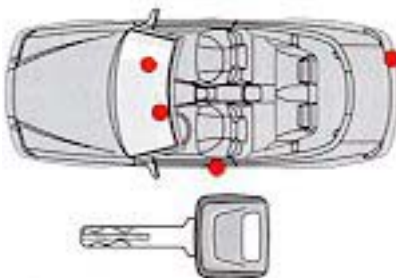

Master key

This key operates all locks (ignition switch/steering wheel lock, driver's door, trunk/tailgate and glove compartment).

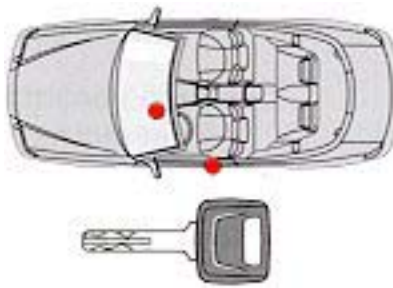

Service key

This key operates the driver's door and the ignition switch/steering wheel lock.

NOTE:

- As an added anti-theft measure, new keys have been developed which may take slightly longer to copy or replace if the original keys are misplaced. Duplicate keys may be ordered from your Volvo retailer.
- The key number codes are stamped on a separate tag supplied with the keys. This tag should be separated from the key ring and kept in a safe place.

Doors and locks

Your car is equipped with a central locking system.

The key, used on the driver's door, the remote control, or central locking button, will lock/unlock both doors, and the trunk.

Turn the key once to unlock the driver's door only.

Turn the key again (within 10 seconds) to unlock both doors and the trunk.

One turn with the key towards lock in the drivers door locks both doors and the trunk.

Use the switch on the front door armrests to lock/unlock the car from the inside.

Check the action of the buttons on the other door to verify its function (lock/unlock).

WARNING! The doors should not be locked while driving. In case of an accident, this may hinder rapid access to the occupants of the vehicle.

NOTE: If a door is not closed completely, the courtesy lights will stay on and a chime will sound until the door is closed.



[Contents](#) | [Top of Page](#)

pg. 43 Remote keyless entry system

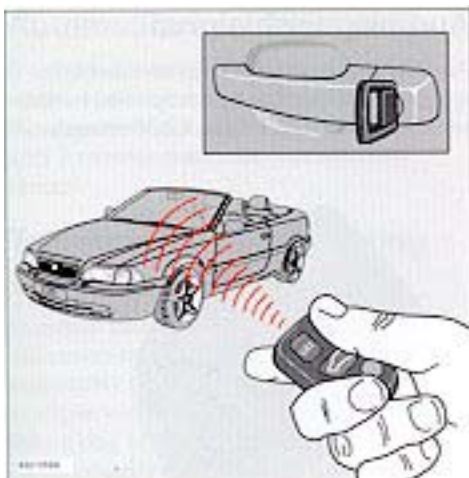

Remote keyless entry system

Your car is equipped with a remote control transmitter. This transmitter uses a radio frequency which will allow “keyless” entry into the passenger compartment or the trunk. You will be supplied with two coded key ring transmitters, which will enable you to lock/unlock both doors and the trunk from a distance of 10-15 feet (3-5 meters).

The car can also be locked/unlocked with the key.

As an extra security precaution in certain situations (valet parking, etc.), Volvo recommends that the transmitter not be included when the keys are given to anyone. The service key can be used instead. If one of transmitters is misplaced, contact the nearest authorized Volvo retailer for assistance.



Using the remote control

- Press the **LOCK** button once to lock both doors and the trunk.
- Press the **UNLOCK** button **once** to unlock the driver’s door only. Press this button again (within 10 seconds) to unlock both doors and the trunk.
- Press the **OPEN TRUNK** button to pop open the trunk.

This device complies with FCC rules Part 15. Operation is subject to the following two conditions: (1) This device may not cause harmful interference and (2) this device must accept any interference that may be received, including interference that may cause undesired operation.

NOTE: If only the driver's door is unlocked, the lock will automatically reengage (re-lock) and the alarm will reset after 2 minutes unless the door has been opened.

The lock/unlock and alarm features can also be utilized by using the keys. [See section: Doors and Locks on page 42.](#)

If the alarm LED glows continuously for 5 seconds, this indicates a fault in the system or that a door is not properly closed.

WARNING! Volvo does not recommend using the transmitter to lock the doors from inside the car. On cars equipped with an alarm, the alarm would be activated and would sound when one of the doors is opened. The doors must not be locked using the remote transmitter while the vehicle is occupied. In case of an accident, this may hinder rapid access to the occupants of the vehicle. The alarm will also sound on models equipped with this feature.

NOTE : To avoid leaving your keys in the car, make a habit of always locking the car with the remote control.

pg. 44 Alarm (certain models)

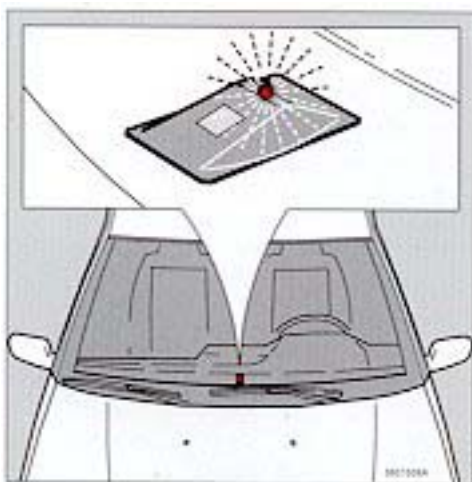

LED alarm status indicator

Alarm

The radio signal emitted from the transmitter, which is used to set/unset the alarm, is a “rolling code” signal. This means that the signal is changed randomly for each transmission and is intended to help prevent unauthorized recording of the code.

When armed (set), the alarm continuously monitors a number of points on the car. The following conditions will set off the alarm:

- The hood is opened
- The trunk/tailgate is opened
- A door is opened
- The ignition switch is tampered with

- The car is lifted or towed (if the car is equipped with the optional inclination sensor)
- The battery is disconnected (if the car is equipped with the optional backup battery siren)

Arming (setting) the alarm

Press the LOCK button on the remote control, lock the car using the key in the driver's door or press the central lock button on one of the front doors with the door open. One long flash of the turn signals will confirm that the alarm is set.

Disarming the alarm

Press the UNLOCK button on the remote control or unlock the doors with the key.

Turning off (stopping) the alarm

If the alarm is sounding, it can be stopped by pressing the UNLOCK button on the remote control or by unlocking the driver's door with the key.

If the alarm is stopped with the remote control, this will be confirmed by two short flashes from the turn signals.

Visual alarm signal

The visual alarm signal is given by flashing all turn signals and turning on the interior lighting for 5 minutes.

Audible alarm signal

An audible alarm signal is given either by a separate alarm horn or by the optional back-up siren. One alarm cycle lasts for 30 seconds.



“Panic“ function

In an emergency situation, this feature can be used to attract attention.

Activate the “panic” function by pressing the red panic button on the remote control for at least 3 seconds or by pressing this button twice within 3 seconds. The turn signals will flash, the interior lights will go on and the alarm will sound.

The function can be turned off by pressing any of the buttons on the remote control or will stop automatically after 25 seconds.

NOTE: This button will **NOT** unlock the car.

Automatic reset function

If only the driver's door is unlocked with the remote control, the lock will automatically reengage (re-lock) and the alarm will reset after 2 minutes unless the door has been opened.

Temporarily disconnecting the alarm sensor(s)

In certain situations it may be desirable to disconnect the **optional** alarm sensor, particularly the inclination sensor, if, for example, you drive your car onto a ferry where the rocking of the boat could trigger the alarm. To temporarily disconnect the sensor(s) from the alarm system:

- With all doors closed, switch off the ignition and remove the key from the ignition switch
- Press the locking (left) side of the central locking button on the driver's door for at least 3 seconds.
- The doors will first lock and then unlock after 3 seconds to confirm that the sensors have been disconnected.

The car can then be locked in the usual way to set the alarm.

NOTE: The sensors will automatically be reconnected to the alarm system the next time the ignition is switched on.

LED alarm status signals

The status of the alarm system is indicated by the red LED at the top center of the dash:

- LED off - the alarm is not armed (set)
- LED flashes once per second - the alarm is armed (set)
- LED flashes rapidly before the ignition is switched on - the alarm has been triggered.
- LED flashed rapidly for 15 seconds after the ignition has been switched on - a fault has been detected in the alarm system.

Contact a Volvo retailer.



Batteries

Each remote transmitter is powered by a three volt battery, type CR2016. If the range of the transmitter is noticeably reduced, this indicates that the battery is weak and should be replaced.

Replacement: Remove the battery cover on the back of the transmitter with a coin. Replace the battery. Reinstall the cover, making sure it is secured tightly to help protect the transmitter.

CAUTION: Do not attempt to service or repair any components of the alarm system yourself. This should only be done by an authorized Volvo retailer.



[Contents](#) | [Top of Page](#)

Electrically operated seats with memory function



- 1 Lumbar support control
- 2 Strap for controlling front seat for rear seat passengers
- 3 Backrest release control lever
- 4 Power seat control panel

Power seat control panel

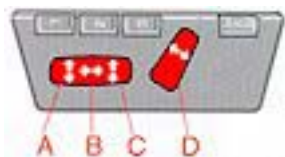

- A- seat front (raise/lower), B- forward/rearward
- C- seat rear (raise/lower), D- backrest tilt

WARNING! The power seats are operable with the ignition OFF. Therefore, children should never be left unattended in the car.

Movement of the seat can be STOPPED at any time by pressing any button on the power seat control panel.



Programming the memory

Three seat positions can be programmed. To program a seat position:

- 1 Adjust the seat to the desired position.
- 2 Depress the MEM button.
- 3 Press button 1 to program the current position of the seat.

Buttons 2 and 3 can be programmed in the same way. To move the seat to a programmed position, depress button 1, 2 or 3 until the seat stops. If the button is released before the seat has reached the programmed position, it will stop as a safety precaution.

NOTE: The seat has an overload protector which engages if an object blocks the movement of the seat. If this happens, remove the object and wait 20 seconds before operating the seat again.

WARNING! Do not adjust the seat while driving. The seat should be adjusted so that the brake pedal can be depressed fully. In addition, position the seat as far rearward as comfort and control allow. The seat rails on the floor must not be obstructed in any way when the seat is moved.

Manually operated passenger's seat (certain models)



1 Height adjustment

The front section of the seat can be adjusted to 7 different height settings (lever A) and the rear section can be adjusted to 9 different height settings (lever B).

2 Forward-rearward seat adjustment

Pull the bar upward, then slide the seat forward or rearward to the desired position. Make sure that the seat is properly secured when you release the bar.

3 Back rest tilt

Rotate the control counterclockwise to tilt the backrest rearward and clockwise to tilt the backrest forward.

4 Lumbar support

5 Strap for controlling front seat for rear seat passengers (see following page)

pg. 47 Front seats

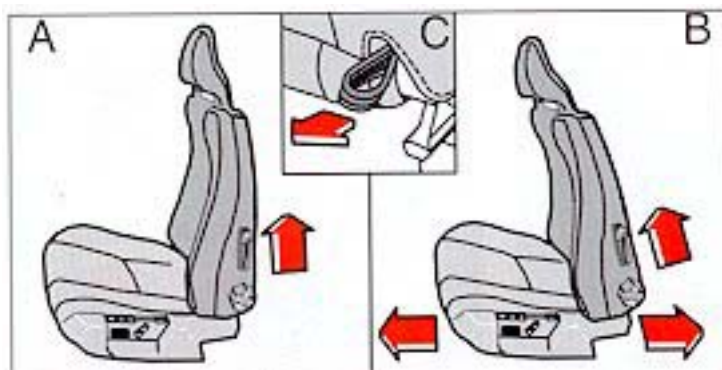

Tilting the backrests - moving the seats

Tilting the backrest

The backrests are locked in the upright position and can be tilted forward to allow access to the rear seat.

- Lift the control lever on the side of the front seat (A) and tilt the backrest forward until it locks into place to reach objects in the rear seat.

Moving the seat forward

- Lift and hold up the control lever on the side of the front seat (A).
- Tilt the backrest forward (B).
- The seat will slide forward until the control lever is released or until it reaches the forward-most position.

To tilt up the backrest to its normal position:

- Press the backrest slightly forward and pull the control lever up to release the backrest locking mechanism.
- Tilt the backrest toward the rear of the car.
- Hold the control lever up to allow the seat to slide back to its original position.

To exit the rear seat:

- Pull the strap on the lower inside corner of the seat.
- Push the backrest forward.
- The seat will slide forward until the strap is released*.

* If the backrest is in the upright position, the seat will slide rearward until the strap is released.

WARNING! Make sure the seats are securely locked into position after they have been adjusted.

pg. 48 Rear/side-view mirrors

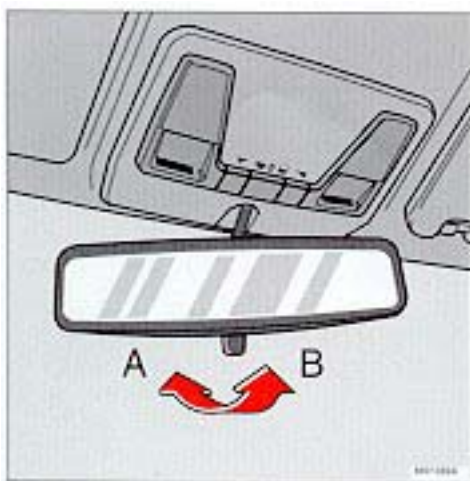

Rear-view mirror

A Normal position

B Night position, reduces glare from following headlights

CAUTION: Never use ice scrapers made of metal as they can easily scratch the mirror surface.

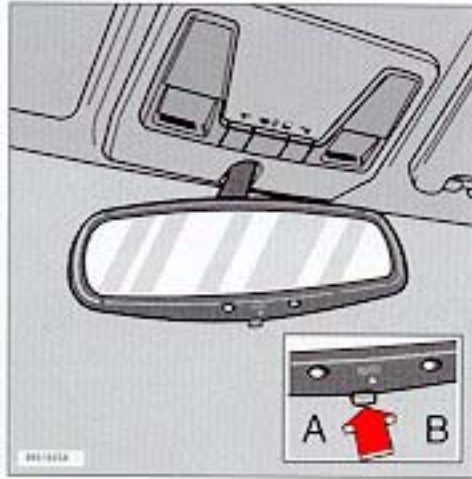

Auto-dim function (certain models)

- A** Auto-dim ON
- B** Auto-dim OFF

The Auto-dim function reacts to high beams from the car behind you and switches the mirror automatically to "night" position.

NOTE: If the right indicator light in the lower (see inset illustration above) is on, The Auto-dim function is disabled (off). Press the button (see arrow) to turn the function ON or OFF.



Adjustment control

Electrically operated side-view mirrors

The mirror control switches are located on the driver's door armrest. Press the left side of the selector button and then use the adjustment control to adjust the driver's door mirror. Press the right side of the selector button before adjusting the passenger door mirror.

- A** Horizontal adjustment

B Vertical adjustment

WARNING! The mirrors should always be adjusted prior to driving. Objects seen in the wide-angle right side-view mirror are closer than they appear to be.



[Contents](#) | [Top of Page](#)

pg. 49 Interior lights, Vanity mirrors

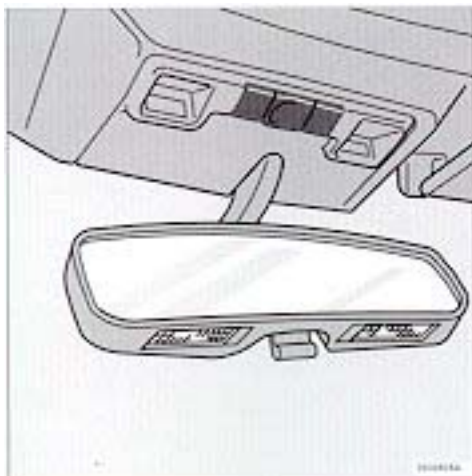

Front courtesy lights

The front courtesy lighting consists of two reading lights for the front seat occupants. The switch can be set in three positions. In the first position the lamps are always off. In the second position the lamps will come on if one of the doors is opened. In the third position, the lamps are always on.

The courtesy lights remain illuminated for 30 seconds after the doors have been closed but will be switched off if the ignition is turned on or the doors are locked. If a door is not closed completely, the courtesy lights will stay on and a chime will sound until the door is closed.

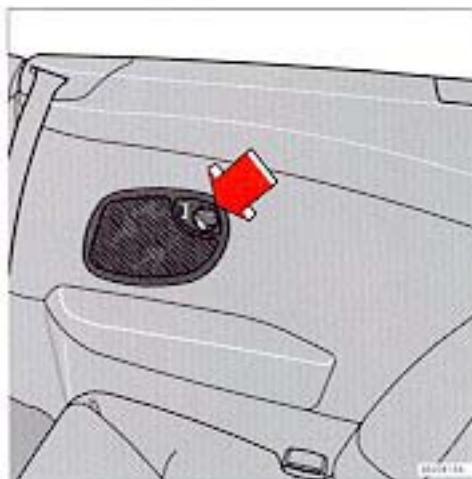

Reading lights, rear seat

There are two reading lamps at opposite sides of the rear seat, near the armrests. These lamps can be turned on/off using the switch (see illustration above).

The switch can be set in three positions. In the first position the lamps are always off. In the second position the lamps will come on if one of the doors is opened. In the third position, the lamps are always on.

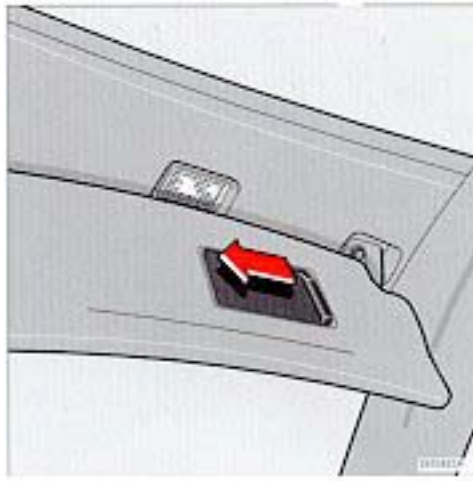

Vanity mirrors

Fold down the sun visor and slide the cover to the side to illuminate the mirror. The illumination will be switched off when the cover is closed or if the sun visor is folded up.

pg. 50 Long load storage

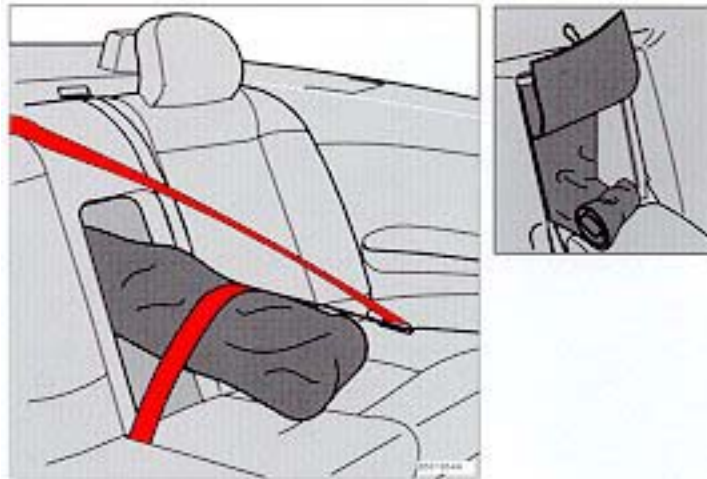

Long load storage

There is a flap located behind the panel in the center of the rear backrest which opens to provide a cargo space for carrying long objects such as skis, carpets, etc. (see illustration). A bag for the object being transported is attached to this opening behind the backrest to help hinder access to the trunk when the convertible top is down.

Please note that this cargo space is intended for light loads only.

A protective covering should be used on the object if necessary to avoid soiling or tearing the upholstery in the passenger compartment.

Max. length: 6 1/2 ft (2 meters) Max. weight: 55 lbs (25 kg)

WARNING! Always turn the engine off and apply parking brake when loading/unloading the vehicle. Place the transmission in the P (PARK) position to help prevent inadvertent movement of the gear selector.

Long loads should be secured to the folded down armrest to help prevent movement and possible injury in the event of sudden braking or stops. Any sharp edges should be covered with protective material.

pg. 51 Hood

Hood release lever under dashboard

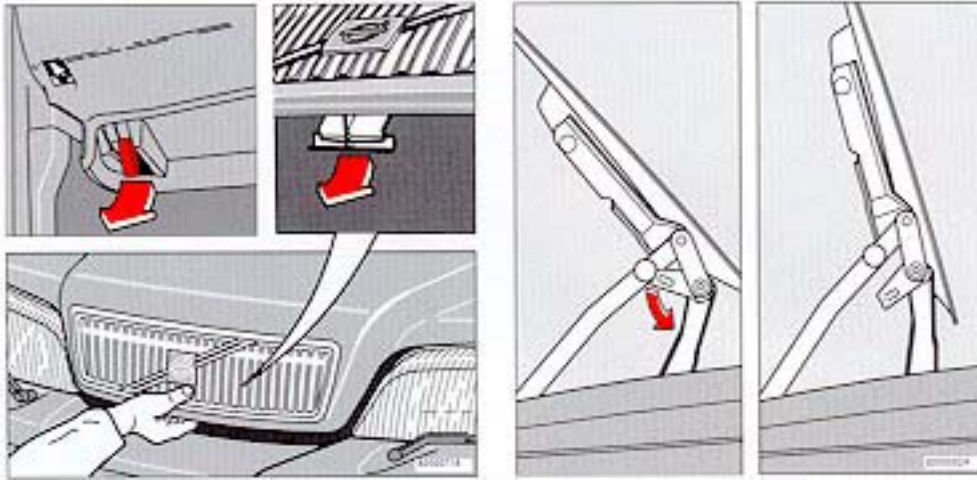

Hood release control under grille

To open the hood

- Pull the lever located under the left side of the dash to release both hood catches.
- Lift the hood slightly.
- Pull the release control on the inside of the lower edge of the grille toward you and lift the hood.

WARNING! Check that the hood locks properly when closed.

The hood normally opens to an angle of 57°. The hood can be opened to the vertical position by rotating the hinge catches (see illustrations). The catches will return to their normal positions when the hood is closed. Ensure adequate clearance in low-roof garages to avoid damaging the hood.



[Contents](#) | [Top of Page](#)

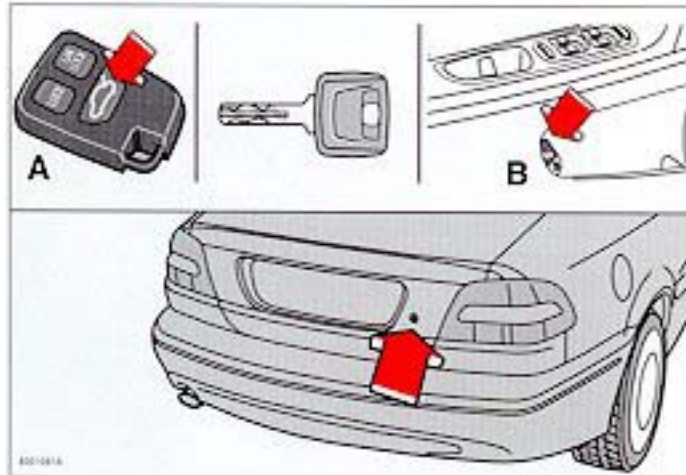

Opening the trunk

The trunk can be opened by:

- Pressing the button on the remote control (A)
- Using the master key in the trunk lock
- Using the trunk control on the driver's door (B)

Locking the trunk

The trunk lock is incorporated in the central locking system. This means that you can either lock or unlock the trunk when the driver's door is locked/unlocked.

The trunk lock can be disconnected from the central locking system by turning the key counterclockwise as shown in the illustration.



Withdraw the key in the horizontal position *

** In this position, the trunk cannot be opened with the control on the driver's door or the remote control.

The trunk is now always locked. This feature can be used for e.g., valet parking. If you give only the service key to the driver, it will not be possible to gain access to the trunk. Please be aware that this setting may preclude access to the spare tire and jack.

To reconnect the lock to the central locking system:



Withdraw the key in the vertical position

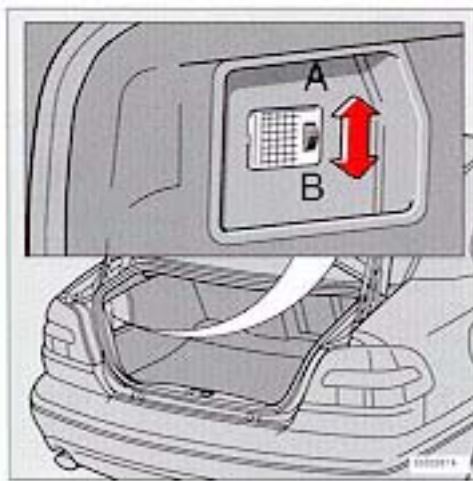

Trunk Light

A Light always off

B Light is on when the trunk lid is open

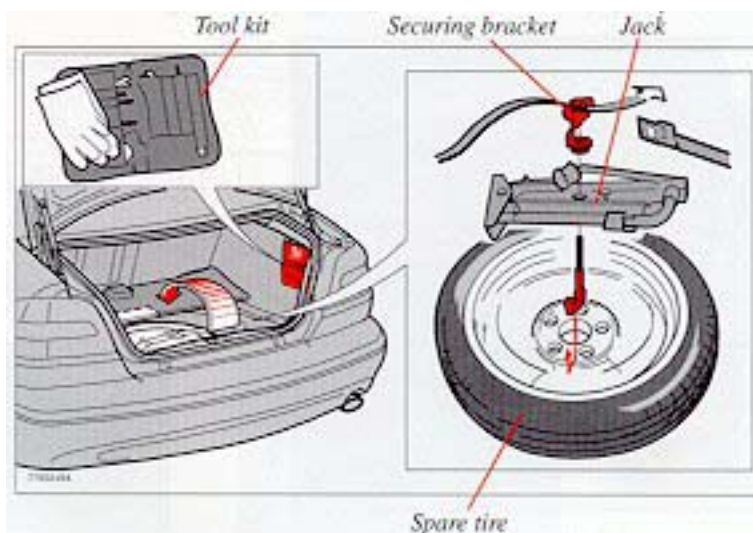

Spare tire

The spare tire is located under the carpet in a special well under the floor of the trunk. The jack is placed inside the wheel rim.

WARNING! Make sure that the jack is properly secured in the wheel rim with the securing bracket. The belt must also be threaded through the slot in the securing bracket (see illustration) and properly fastened to help keep the spare wheel/jack in place in the event of a sudden stop.

NOTE: [See pages 84-85 for information on how the jack should be used.](#)

pg. 54 Securing cargo, Avoiding battery drain

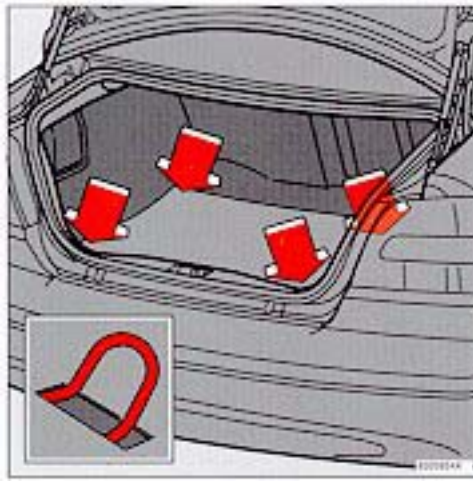

Eyelets in trunk

Securing cargo

As a safety precaution, your car is equipped with four eyelets to which straps can be attached to secure luggage.

WARNING! The eyelets are not to be used as passenger restraints or as anchorages for child restraints. [See page 10.](#)

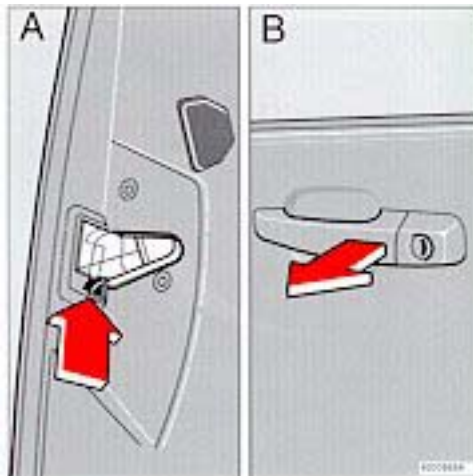

Avoiding battery drain

The courtesy lights and the warning lights in the rear of the doors come on when a door is opened.

- To avoid battery drain when the doors are opened for prolonged periods, these lights can be switched off by pressing the lock mechanism (A) located in the rear facing side of the driver's door.
- To return the lights to their normal function, pull the door handle out before closing the door (B) and use a small screwdriver to push the lock mechanism back to its original position before closing the door.

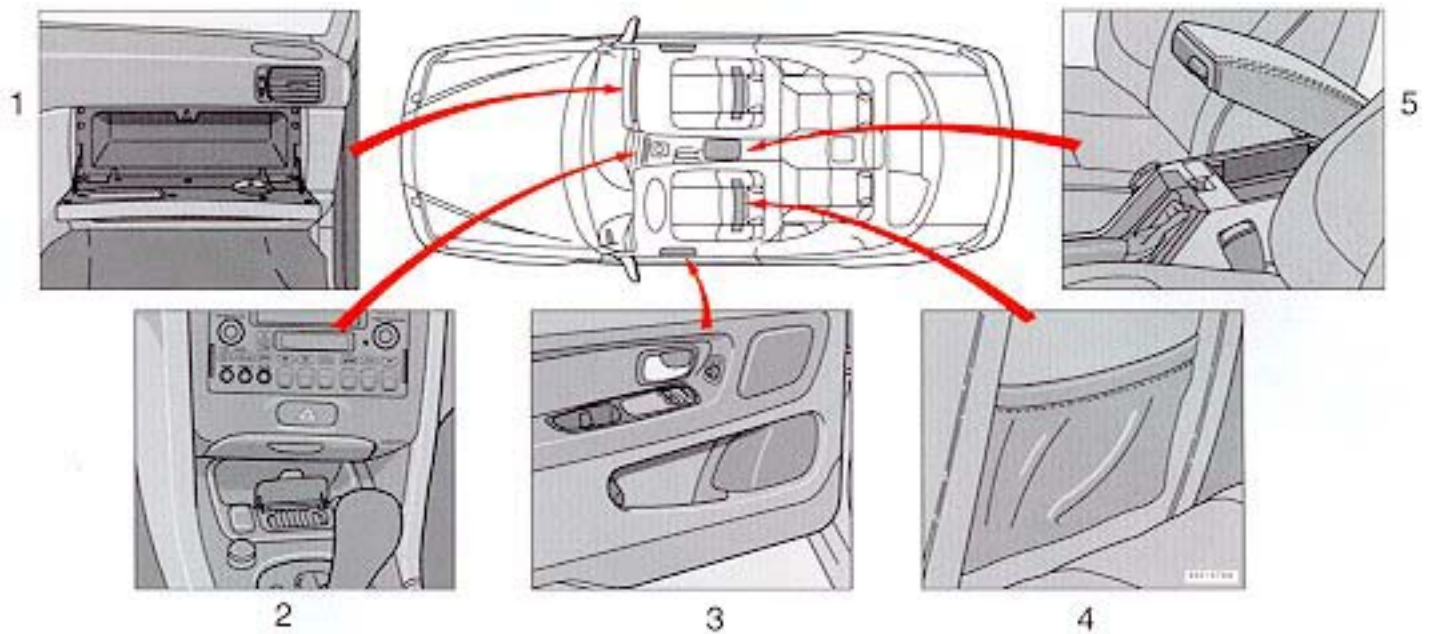

1. Glove compartment
2. Coin holder
3. Compartment in door
4. Pocket on rear of front seat
5. Compartment between front seats/Cup holder

WARNING! Always secure large, sharp or heavy objects using the seat belts to avoid personal injury in the event of sudden braking or abrupt stops. See [page 50](#) for information on storing long items.



[Contents](#) | [Top of Page](#)

Chapter 4 - Starting and driving

pg. 57 Starting and driving

Starting and driving

This section on starting and driving contains items such as starting the engine, operating the gear selector, towing, trailers, etc.

<u>Break-in period</u>	<u>58</u>
<u>Fuel requirements, Refueling</u>	<u>58-59</u>
<u>Driving economy</u>	<u>60</u>
<u>Starting the engine</u>	<u>61</u>
<u>Manual transmission</u>	<u>62</u>
<u>Automatic transmission</u>	<u>63</u>
<u>Points to remember</u>	<u>66</u>
<u>Emergency towing</u>	<u>68</u>
<u>Vehicle towing information</u>	<u>69</u>
<u>Jump starting</u>	<u>70</u>
<u>Three-way catalytic converter</u>	<u>71</u>
<u>ABS, Brake system</u>	<u>72</u>
<u>Trailer towing</u>	<u>73</u>
<u>Winter driving</u>	<u>74</u>
<u>Storing the car for extended periods, Long distance trips</u>	<u>75</u>

pg. 58 Break-in period, Fuel requirements

A new car should be broken-in

Refrain from utilizing your car's full driving potential during the first 1,200 miles (2,000 km) including

the "kick-down" function (automatic transmission).

NOTE - ENGINE OIL:

Although some oil consumption occurs during normal engine operation, more oil is consumed when the engine is new as the internal parts generate higher friction while wearing-in to each other. **From the time the engine is new until the first service is performed, the oil consumption could be higher than normal. For this reason, it is especially important to check the oil every time you refuel your car during this period. [See page 116.](#)**

In general, the rate of oil consumption depends on such factors as: engine temperature, length of trip, driving conditions, oil viscosity and quality, engine speed and acceleration/deceleration.

Checking your engine oil level each time the car is refueled is one of the most important items you can perform to help keep your car in good running order.

Manual transmission

The following speeds should not be exceeded during the break-in period:

	Up to 600 miles (1000 km)	600 - 1,200 miles (1000 - 2000 km)
1st gear	20 mph (30 km/h)	25 mph (40 km/h)
2nd gear	30 mph (50 km/h)	40 mph (70 km/h)
3rd gear	45 mph (80 km/h)	65 mph (100 km/h)
4th gear	70 mph (110 km/h)	80 mph (130 km/h)
5th gear/overdrive	80 mph (130 km/h)	95 mph (150 km/h)

Posted speed limits should not be exceeded.

Deposit control gasoline (detergent additives)

Volvo recommends the use of gasoline containing deposit control additives. These additives have shown to be efficient in keeping injectors and intake valves clean. Consistent use of deposit control gasolines will help ensure good driveability and fuel economy. If you are not sure whether the gasoline contains deposit control additives, check with the service station operator.

Unleaded Fuel

Each Volvo has a three-way catalytic converter and must use only unleaded gasoline. U.S. and Canadian regulations require that pumps delivering unleaded gasoline be labeled "UNLEADED". Only these pumps have nozzles which fit your car's filler inlet. It is unlawful to dispense leaded fuel into a vehicle labeled "unleaded gasoline only". Leaded gasoline damages the three-way catalytic converter and the heated oxygen sensor system. Repeated use of leaded gasoline will lessen the effectiveness of the emission control system and could result in loss of emission warranty coverage. State and local vehicle inspection programs will make detection of misfueling easier, possibly resulting in emission test failure for misfueled vehicles.

NOTE: Some U.S. and Canadian gasolines contain an octane enhancing additive called methylcyclopentadienyl manganese tricarbonyl (MMT). If such fuels are used, your Emission Control System performance may be affected, and the Malfunction Indicator Lamp located on your instrument panel may light. If this occurs, please return your vehicle to an authorized Volvo retailer for service.

Octane Rating

Volvo engines are designed for optimum performance on unleaded premium gasoline with an octane rating. AKI of 91, or above. AKI (ANTI KNOCK INDEX) is an average of the Research Octane Number, RON, and the Motor Octane Number, MON, $(RON + MON / 2)$.

The minimum octane requirement is AKI 87 (RON 91).

pg. 59 Fuel requirements, Refueling

Gasoline containing alcohol and ethers

"Oxygenated fuels"

Some fuel suppliers sell gasoline containing "oxygenates" which are usually alcohols or ethers. In some areas, state or local laws require that the service pump be marked indicating use of alcohol or ethers. However, there are areas in which the pumps are unmarked. If you are not sure whether there is alcohol or ethers in the gasoline you buy, check with the service station operator.

To meet seasonal air quality restrictions, some states require the use of "oxygenated" fuel in certain areas.

Volvo allows the use of the following "oxygenated fuels; however, the octane ratings listed on this page must still be met.

Alcohol — Ethanol

Fuels containing up to 10% ethanol by volume may be used.

Ethanol may also be referred to as Ethyl alcohol, or "Gasohol".

Ethers — MTBE

Fuels containing up to 15% MTBE may be used.

Refueling

The fuel tank is designed to hold approximately 18.4 US gal. (70 liters) with sufficient volume left over to accommodate possible expansion of the fuel in hot weather. Be aware that the "usable" tank will be somewhat less than the specified maximum. When the fuel level is low, such factors as ambient temperature, the fuel's "vapor pressure" characteristics, and terrain can affect the fuel pumps' ability to supply the engine with an adequate supply of fuel. Therefore, it is advisable to refuel as soon as possible when the needle nears the red zone, or when the fuel warning light comes on.

The fuel filler cap is located inside the fuel tank cover on the right rear fender.

NOTE: The fuel tank cover is locked and must be popped open using the control on the driver's door ([see page 37](#)).

Open fuel filler cap slowly during hot weather conditions.

When filling, hang the cap on the special bracket on the inside of the fuel tank cover.

NOTE: Turn the ignition off or to position I when refueling. If the ignition is on, an incorrect reading could occur in the fuel gauge (low fuel level will be indicated).

After filling the tank, install the cap and turn until a "click" is heard*.

During a transitional period, a small number of service stations may still have fuel nozzles that are not compatible with the fuel filler neck on cars equipped with the evaporative control system (ORVR). Please refer to [page 114](#) for additional information.

CAUTION:

- Do not refuel with the engine running. After refueling, close the fuel filler cap by turning it clockwise until it clicks into place.
- Allow for fuel expansion by not overfilling the tank. Overfilling could also cause damage to the emission control systems.
- Avoid spilling gasoline during refueling. Gasolines containing alcohol can cause damage to painted surfaces, which may not be covered under the New Vehicle Limited Warranty.
- Do not use gasoline containing methanol (methyl alcohol, wood alcohol). This practice can result in vehicle performance deterioration and can damage critical parts in the fuel system. Such damage may not be covered under the New Vehicle Limited Warranty.

* If the fuel filler cap is not closed tightly or if the engine is running when the car is refueled, the Malfunction Indicator Lamp may indicate a fault. Use only Volvo original or approved fuel filler caps.



[Contents](#) | [Top of Page](#)

pg. 60 Driving economy

Economical driving conserves natural resources

Better driving economy may be obtained by thinking ahead, avoiding rapid starts and stops and adjusting the speed of your vehicle to immediate traffic conditions. Observe the following rules:

- Bring the engine to normal operating temperature as soon as possible by driving with a light foot on the accelerator pedal for the first few minutes of operation. A cold engine uses more fuel and is subject to increased wear.
- Whenever possible, avoid using the car for driving short distances. This does not allow the engine to reach normal operating temperature.
- Drive carefully and avoid rapid acceleration and hard braking.
- Do not exceed speed limit.
- Avoid carrying unnecessary items (extra load) in the car.
- Check tire pressure regularly (check when tires are cold).
- Remove snow tires when threat of snow or ice has ended.
- Note that roof racks, ski racks, etc., increase air resistance and thereby fuel consumption.
- Avoid using automatic transmission kick-down feature unless necessary.
- Avoid using the air conditioning when it is not required. When engaged, the air conditioner's compressor places an additional load on the engine. However, please note that fuel consumption is lower with the air conditioning on than it is when driving with the air conditioning switched off and the windows down.
- If your car is equipped with the optional Trip Computer, utilizing the fuel consumption modes can help you "learn" how to drive more economically.

Other factors which decrease gas mileage are:

- Worn or dirty spark plugs
- Incorrect spark plug gap
- Dirty air cleaner
- Dirty engine oil and clogged oil filter
- Dragging brakes
- Incorrect front end alignment

Some of the above mentioned items and others are checked at the standard Maintenance Service intervals.

NOTE: (D)rive or 5th gear (manual transmissions) should be used as often as possible to help improve fuel economy.

pg. 61 Starting the engine

Starting and stopping

1. Fasten the seat belt.

WARNING! Before starting, check that the seat and steering wheel are adjusted properly. Make sure the brake pedal can be depressed completely. Move the seat closer if necessary. [Refer to section "front seats"](#).

2. Apply the parking brake, if not already set. The gear selector (**automatic transmission**) is locked in the (P)ark position (**SHIFT LOCK**).
3. **Without touching the accelerator pedal**, turn the ignition key to the starting position. Allow the starter to operate for up to 10 seconds. Release the key as soon as the engine starts. If the engine fails to start, repeat step 3.

For cold starts at altitudes above 6000 ft (1800 meters), depress the accelerator pedal halfway and turn the key to the starting position. Release the pedal slowly when the engine starts.

4. To release the gear selector from the (P)ark position (automatic transmission), the ignition key must be in position II and the brake pedal must be depressed. [See page 99 for instructions on manually overriding the SHIFTLCK system.](#)

Do not race a cold engine immediately after starting. Oil flow may not reach some lubricating points fast enough to prevent engine damage.

NOTE: (Automatic transmission only) Your car is equipped with a **KEYLOCK** system. When the engine is switched off, the gear selector must be in the (P)ark position before the starting key can be removed from the ignition switch.

5. Select desired gear. The gear engages after a slight delay (automatic transmission) which is especially noticeable when selecting R.

CAUTION: (Automatic transmission only) The engine should be idling; never accelerate until after you feel the gear engage! Too-rapid acceleration immediately after selecting a gear will cause harsh engagement and premature transmission wear.

NOTE: Selecting P or N (automatic transmission) when idling at a standstill for prolonged periods of time will help prevent overheating of transmission oil.

WARNING! Always place the gear selector (automatic transmission) in Park and apply the parking brake before leaving the vehicle. Never leave the car unattended with the engine running. Always open the garage doors fully before starting the engine inside a garage to ensure adequate ventilation. The exhaust gases contain carbon monoxide, which is invisible and odorless but very poisonous.

CAUTION:

Never race the engine **immediately after starting**. Oil flow may not reach some lubricated points fast enough to prevent engine damage.

Do not race the engine just prior to switching off!

Hydraulic valve lifters

This engine features hydraulic valve lifters which means that valve clearance is adjusted automatically. It is possible that the valve lifters will produce a ticking sound for the first few seconds after the engine is started, while the oil pressure is increasing.

If the car has not been used for a long period of time, this ticking sound may last for up to 15 minutes. This is entirely normal.

Do not exceed 3000rpm until the ticking sound disappears.



[Contents](#) | [Top of Page](#)

pg. 62 Manual transmission

**Shift positions**

Depress the clutch pedal completely when changing gears.

Remove your foot from the clutch pedal while driving.

Overdrive (5th gear) should be used as often as possible to help improve fuel economy. This gear can be engaged at speeds above approx. 50 mph (80 km/h).

CAUTION: Follow the shift pattern indicated on the gear shift knob when shifting up (e.g. do not shift directly from 2nd to 5th gear) to help avoid excessive wear on the transmission.

**Engaging reverse gear**

The gear lever must first be moved to neutral in order to engage reverse gear.

CAUTION: Be careful that you do not inadvertently engage reverse while moving forward.

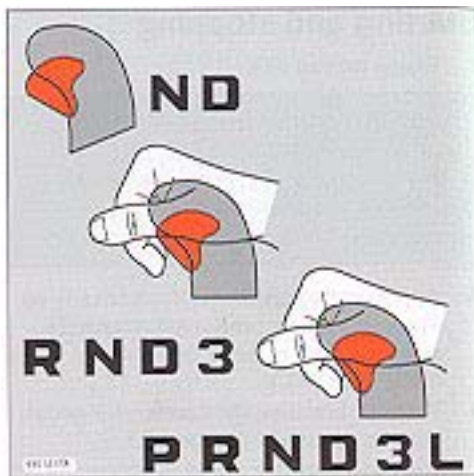

Automatic transmission - shift gate positions

The gear selector can be moved freely between N and D. Selections of other positions are obtained by depressing the selector knob prior to moving the selector.

Slightly depressing the selector knob allows selection of positions R, N, D, 3 and L. Fully depressing the selector knob allows selection of position P. This is also necessary when initially bringing the selector out of position P. Fully depressing the selector knob permits shifting freely between all positions.

pg. 63 Automatic transmission

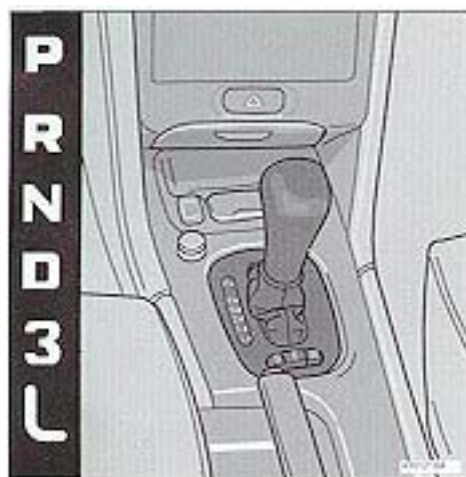

P (Park)

Use this position when starting the engine or parking the car.

Never use P while car is in motion.

The parking brake should also be used when parking on grades.

The gear selector is mechanically locked in the P position (SHIFT LOCK).

To release the selector, start the engine and depress the brake pedal. If it is necessary to manually release the gear selector, [see page 99 for instructions.](#)

WARNING! Never leave the car when the engine is running. If, by mistake, the gear selector is moved from P, the car may start moving.

R (Reverse)

Never engage R while is moving forward.

N (Neutral)

Neutral = no gear engaged. Use the parking brake. The engine can be started with the gear selector in this position.

D (Drive)

D is the normal driving position and should be used as often as possible to help improve fuel economy. When modes **E** or **S** are selected, upshift and downshift of the forward gears occur automatically and are governed by accelerator pedal position and vehicle speed.

3 (Intermediate position)

The indicator lamp in the instrument panel  and the lamp in the **W** mode selector light up when this gear is selected. Automatically shifts up and down between 1st, 2nd, and 3rd gears when in driving modes E or S. There is no upshift from 3rd gear. Position 3 can be used for driving in hilly terrain, for towing trailers or for increased engine braking power.

L (Low position)

The indicator lamp in the instrument panel  and the lamp in the **W** mode selector light up when this gear is selected. No upshift can occur when L is engaged. Select position L for driving in first and second gears. Use this position to select low gear with no upshift, e.g. when ascending and descending steep grades. The transmission will noticeably shift down from second to first if road speed drops to below 40 km/h (25 mph) when driving in E Mode and below 10 km/h (6 mph) in S Mode.

Kick-down

Automatic shift to a lower gear (kick-down) is achieved by depressing the accelerator pedal fully and briskly. An upshift will be achieved when approaching the top speed for a particular gear or by releasing the accelerator pedal slightly. Kick-down can be used for maximum acceleration or when passing at highway speeds.

"Lock-up"

The transmission has a "lock-up" function which reduces engine speed and saves fuel. "Lock-up" can sometimes be felt as an additional gear change.

pg. 64 Automatic transmission (cont.)

Driving mode selector

The buttons at the base of the gear lever allow you to select driving modes E, S, or W. A new mode can be selected at any time, including while the car is moving.

W Winter/Wet mode

Enhanced Vehicle Traction

This mode may be selected for starting/moving off on slippery roads.

- In position D*, the gearbox starts in 3rd gear and changes up to 4th gear.
- In position 3*, 2nd gear is locked and there is no change up to 3rd gear.
- In position L, 1st gear is locked.

The indicator lamp in the instrument panel  lights up when this mode is selected (the lamp will also light up if the gear selector is in position 3 or L). Press W to disengage this mode.

When this mode is disengaged or if the ignition is switched off**, the gearbox automatically reverts to the previously selected mode. If the indicator lamp  begins to flash, this is an indication of a fault in the automatic gearbox. The Malfunction Indicator lamp will also light up if a fault is detected. If the transmission does not shift properly, place the gear selector in position L. Please contact your Volvo retailer if this occurs.

CAUTION: Driveability and fuel economy will be adversely affected by prolonged driving in **Winter/Wet mode**. Volvo recommends using this mode only when starting in extremely slippery conditions.

E Economy Mode

This mode is used for normal driving. The gearbox changes gears at a lower engine speed to achieve the best possible fuel consumption.

S Sport Mode

This mode is adapted to "sporty" driving characteristics. The transmission upshifts at higher engine speeds and less accelerator pedal pressure is required to initiate a downshift.

CAUTION:

- Never select P or R while the car is in motion.
- When initially selecting positions D, 3, L or R, your right foot should press firmly on the brake pedal to ensure that the car is standing still with the engine idling.
- The gear selector should not be downshifted to L at speeds above 75 mps (125 km/h).***

* These positions always offer the kick-down function.

** If the ignition is switched on again within several minutes, mode W will remain engaged.

*** Always observe posted speed limits.

pg. 65 Automatic transmission

Special tips - automatic transmission

- For driving down steep hills and when driving for prolonged periods at low speeds, position L should be selected. Avoid, however, repeated changes since this can cause overheating of the transmission oil. For driving on long continuous uphill gradients, select position 3.
- Never select P or R while the car is in motion.
- When initially selecting positions D, 3, L or R, your right foot should press firmly on the brake pedal to ensure that the car is standing still with the engine idling.
- The gear selector should not be downshifted to L at speeds above 75 mph (125 km/h). **Always observe posted speed limits.**
- Do not hold the car stationary on an incline by using the accelerator pedal. Instead, apply the hand brake (parking brake). This prevents the transmission oil from becoming overheated.
- When towing a trailer, select shift position 3.
- The (E)conomy mode should be selected when the cruise control is engaged.
- While towing a trailer in hilly terrain, do not drive continuously at engine speeds above 4500 rpm to help avoid high engine oil temperatures.



[Contents](#) | [Top of Page](#)

Cooling system

The risk for engine overheating is greatest, especially in hot weather, when:

- Towing a trailer up steep inclines for prolonged periods at wide open throttle and low engine rpm.
- Stopping the engine suddenly after high speed driving (so-called "after-boiling" can occur).
- To avoid overheating, the following rules should be followed:
 - Do not drive for prolonged periods at engine speeds above 4500 rpm if you are towing a trailer in hilly terrain.
 - Reduce speed and downshift when towing a trailer up long, steep inclines. The risk of overheating can be reduced by switching off the air conditioning system for a short time.
 - Do not let the engine idle unnecessarily for prolonged periods.
 - Do not mount auxiliary lamps in front of the grill.

When the risk of overheating is imminent, or in the event of overheating (the temperature gauge goes repeatedly into, or stays continually in, the red section), the following precautions should be taken:

- Switch off the air conditioning system.
- Stop the car and put the gear lever into neutral. **Do not stop the engine!**
- Switch the heater to full (maximum) position. Increase the engine speed to approx. 2000 rpm (twice idling speed) until the temperature begins to drop.

WARNING! Do not remove coolant expansion tank cap. The coolant will be extremely hot.

[See "Coolant" to check and top-up the coolant level if necessary.](#)

CAUTION: Drive slowly and carefully if going through standing water (i.e. flooded roadways, etc.) Damage to engine could result if excess water is ingested through the air intake system. Never drive the vehicle in water deeper than 1 foot (300 mm). [See flood warning on page 7.](#)

WARNING! Do not drive with trunk lid open! Poisonous exhaust gases may enter via the open trunk lid.

If the trunk lid must be kept open for any reason, proceed as follows:

- Close the windows.
- Set the ventilation system control to air flow to floor, windshield and side windows and blower control to its highest setting.

Electrical system

When replacing the battery or when carrying out work involving the electrical system, the following should be observed:

- A battery connection to the wrong terminal will damage the diodes. Before connections are made, check the polarity of the battery with a voltmeter.
- If booster batteries are used for starting, they must be properly connected to minimize the risk of the diode being damaged. For correct connection, [see "Jump starting" section](#).
- Never disconnect the battery circuit (for example, to replace the battery) while the engine is running, as this will immediately ruin the generator. Always make sure that all the battery connections are properly tightened.
- If any electrical welding work is performed on the vehicle, the battery's ground lead (negative cable) and all the connecting cables of the generator must be disconnected and the welder cables placed as near the welding points as possible.
- The radio must be turned off before the battery is disconnected.
- The anti-theft code must be re-entered before the radio will function properly.
- The electrical system in your car is designed to accommodate Volvo accessories. It also has an accessory connector located beneath the dashboard on the driver's side.

pg. 67 Points to remember (cont.)

Weight distribution affects handling

At the specified curb weight your car has a tendency to understeer, which means that the steering wheel has to be turned more than might seem appropriate for the curvature of a bend. This ensures good stability and reduces the risk of rear wheel skid. Remember that these properties can alter with the vehicle load. The heavier the load in the trunk (max. 220 lbs, 100 kg), the less the tendency to understeer.

Handling, roadholding

Vehicle load, tire design and inflation pressure all affect vehicle handling. Therefore, check that the tires are inflated to the recommended pressure according to the vehicle load. [See "Tire pressure" section](#).

Loads should be distributed so that capacity weight or maximum permissible axle loads are not

exceeded.

WARNING! It is recommended that tire of the same make and dimensions be used on all four wheels (including the use of snow tires). Do not use bias ply tires as this will adversely alter vehicle handling characteristics.

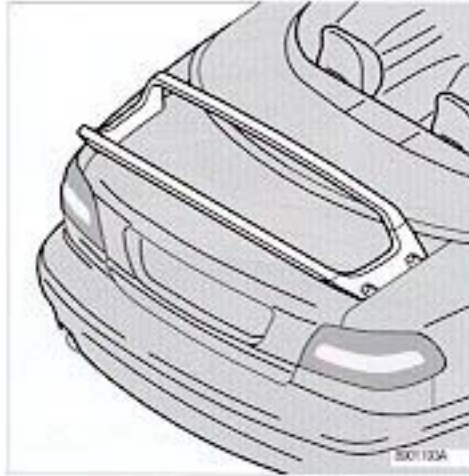

Using trunk-mounted luggage racks

- Use sturdy luggage racks that can be securely attached to the car. Luggage racks specially designed for the Volvo C70 convertible are available at your Volvo retailer.
- Regularly check that the luggage rack is securely attached.
- The maximum permitted load is 110 lbs. (50 kg).
- Spread the load evenly over the entire luggage rack. Avoid single-point loads.
- Place the heaviest load at the bottom.
- Remember that the car's center of gravity is altered by the weight of the load.
- Bear in mind that using a luggage rack increases wind resistance and fuel consumption.
- Anchor the load securely with suitable ropes or bands intended for this purpose
- Drive smoothly, avoiding rapid starts, hard cornering and abrupt stops.
- Objects on the luggage rack should be positioned so that they do not cover the tail lights or obstruct the movement of the convertible top or the Roll Over Protection System (ROPS).

NOTE: A luggage rack is a supplementary loading space intended for light loads only.

WARNING! An extra mat on the driver's floor can cause the accelerator pedal to catch. Check that the movement of the accelerator pedal is not impeded. Not more than one protective floor covering may be used at one time.

pg. 68 Emergency towing (pulling of vehicle)

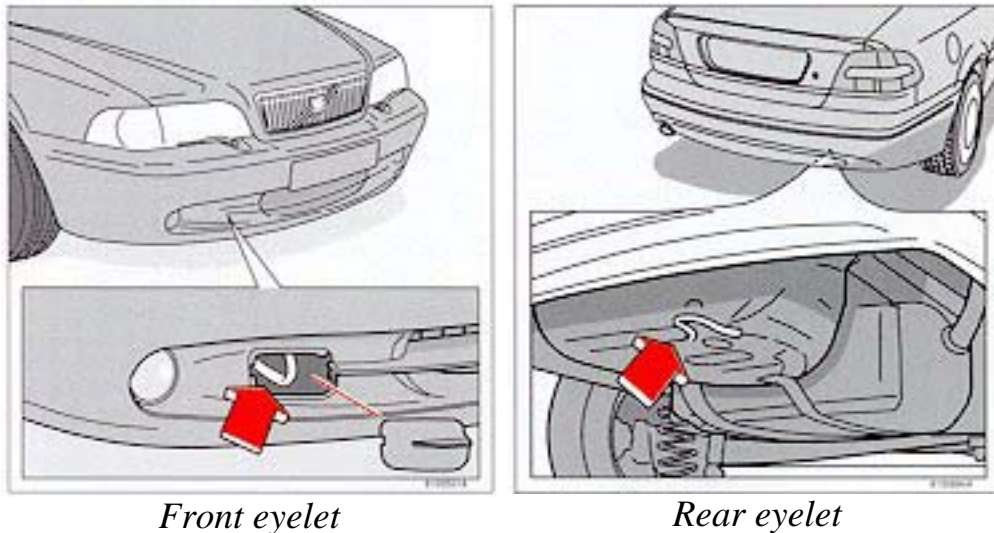

Front eyelet

Rear eyelet

Precautions when the car is in tow

- Steering must be unlocked.
- **Please check with state and local authorities before attempting this type of towing, as vehicles being towed are subject to regulations regarding maximum towing speed, length and type of towing device, lighting, etc.**
- Remember that power brake and power steering assists will not be available when engine is inoperative. Brake pedal pressure required is 3 - 4 times above normal and greater steering effort must be exerted.

Automatic transmissions only:

- Gear selector in position N. Check transmission oil level (see section titled "[Transmission oil](#)").
- Maximum speed: 20 mph (30 km/h).
- Maximum distance with front wheels on ground: 20 miles (30 km).
- If the battery is dead, it is not possible to release the gear selector by pressing the brake pedal. Release the gear selector manually, by pressing the OVERRIDE button near the base of the gear selector.

CAUTION: The towing eyelets must not be used for pulling another vehicle out of a ditch or any similar purpose involving severe strain.

Do not attempt to start the car by pushing or pulling it as damage to the three-way catalytic converter can result.

Only use flat bed equipment *

CAUTION:

- Sling-type equipment applied at the front will damage radiator and air conditioning lines.
- It is equally important not to use sling-type equipment at the rear or apply lifting equipment inside the rear wheels; serious damage to the rear axle may result.

- If it is necessary to have your car towed, a flat bed tow truck should be used if at all possible.
- **In the event that flat bed equipment is not available, the car should be towed with the rear wheels on the ground, if at all possible.**
- If it is absolutely necessary to tow the vehicle with the front wheels on the ground, please refer to the towing information on the previous page.

* If wheel lift equipment must be used, please use extreme caution to help avoid damage to the car.

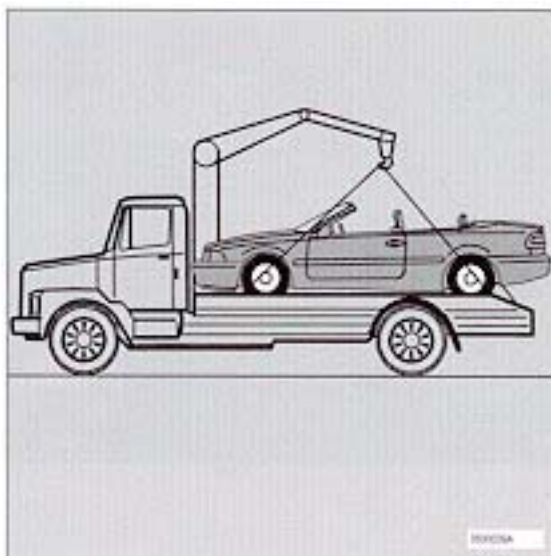

WARNING!

Do not use the towing eyelets on the car to pull the car up on to a flat bed tow truck.



[Contents](#) | [Top of Page](#)

pg. 70 Jump starting

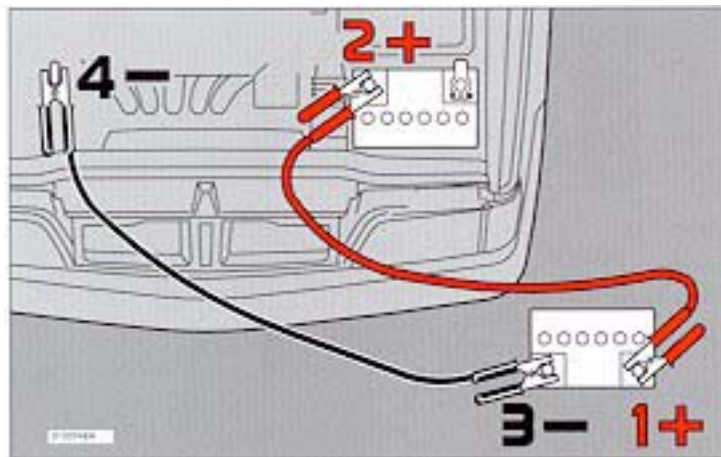

Jump starting

If the 12-volt booster battery to be used is in another car, check that the cars are not touching to prevent premature completion of a negative circuit. Note the position of the battery terminals and using jumper cables:

- First connect the booster battery positive (+) terminal (1) to car battery positive (+) terminal (2).
- Then connect booster battery negative (-) terminal (3) to a stationary solid metal part on the engine at a point away from the battery (4).

Do not connect the jumper cable to any part of the fuel system or to any moving parts. Avoid touching hot manifolds.

After the engine has started, first remove the negative (-) terminal jumper cable. Then remove the positive (+) terminal jumper cable.

CAUTION: Improper hook-up of jumper cables or use of other than 12-volt batteries could result in damage to equipment and/or the battery.

WARNING!

- To reduce the possibility of explosion, never expose the battery to open flame or electric spark.
- Do not smoke near the battery.
- Batteries generate hydrogen gas which is flammable and explosive.
- Battery fluid contains sulfuric acid. Do not allow the battery fluid to contact eyes, skin, fabrics or painted surfaces. If contact occurs, flush the affected area immediately with water. Obtain medical help immediately if eyes are affected.

Failure to follow the instructions for jump starting can lead to personal injury.

NOTE: [Refer to page 124 for information on properly maintaining the battery.](#)

pg. 71 Three-way catalytic converter

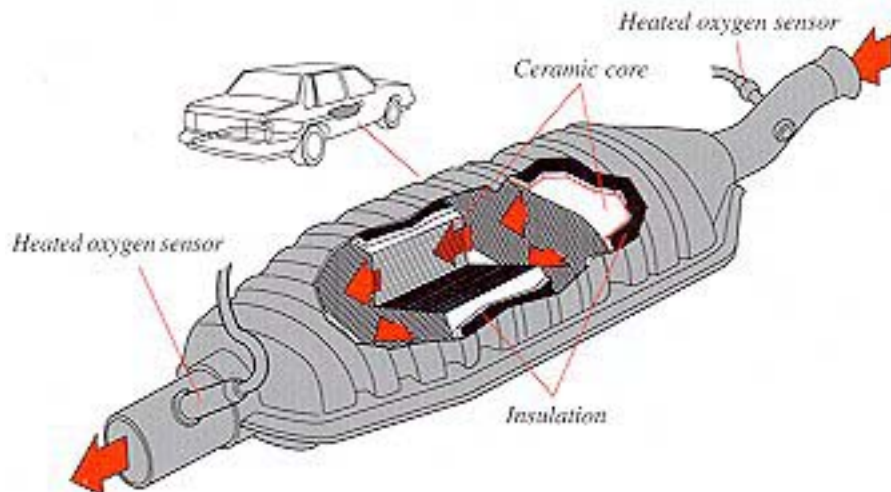

Three-way catalytic converter cautions

- Keep your engine properly tuned. Certain engine malfunctions, particularly involving the electrical, fuel or distributor ignition systems, may cause unusually high three-way catalytic converter temperatures. **Do not continue to operate your vehicle if you detect engine misfire, noticeable loss of power or other unusual operating conditions, such as engine overheating or backfiring.** A properly tuned engine will help avoid malfunctions that could damage the three-way catalytic converter.
- Do not park your car over combustible materials, such as grass or leaves, which can come into contact with the hot exhaust system and cause such materials to ignite under certain wind and weather conditions.
- Excessive starter cranking (in excess of one minute), with an intermittently firing or flooded engine, can cause three-way catalytic converter or exhaust system overheating.
- Remember that tampering or unauthorized modification to the engine or the vehicle may be illegal and can cause three-way catalytic converter or exhaust system overheating. This includes:
 - Altering fuel injection setting or components.
 - Altering emission system components or location or removing components.
 - Repeated use of leaded fuel.

NOTE: Unleaded fuel is required for cars with three-way catalytic converters.

pg. 72 Brake system

ABS

Anti-lock Brake System (ABS)

If the warning lamp lights up there is a malfunction of the ABS system (the standard braking system will however function) and the vehicle should be driven cautiously to a Volvo retailer for inspection. The Anti-lock Braking System (ABS) helps to improve vehicle control (stopping and steering) during severe braking conditions by limiting brake lock-up. When the system "senses" impending lock-up, braking pressure is automatically modulated in order to help prevent lockup, which could lead to a skid.

The system performs a self-diagnostic test when the vehicle first reaches a speed of approximately 12 mph (20 km/h). The brake pedal will pulsate several times and a sound may be audible from the ABS control module. This is normal.

To obtain optimal effect from the ABS system, constant pressure should be kept on the brake pedal while the system is modulating the brakes. Do not pump the brake pedal.

The switching of the ABS modulator will be audible and the brake pedal will pulsate at this time. Please be aware that ABS does not increase the absolute braking potential of the vehicle. While control will be enhanced, ABS will not shorten stopping distances on slippery surfaces.



Brake circuit malfunction

If one of the brake circuits should malfunction, the red warning light will come on, the pedal stroke increases slightly, the pedal feels softer and extra pressure is required for normal braking. If the light comes on while driving or braking, stop immediately and check the brake fluid level in the reservoir.

WARNING! If the fluid level is below the MIN mark in either section of the reservoir: **DO NOT DRIVE.** Tow the car to a Volvo retailer and have the brake system checked and any leakage repaired.

Moisture on brake discs and brake pads affects braking

Driving in rain and slush or passing through an automatic car wash can cause water to collect on the brake discs and pads. This will cause a delay in braking effect when the pedal is depressed. To avoid such a delay when the brakes are needed, depress the pedal occasionally when driving through rain, slush etc. This will remove the water from the brakes. Check that brake application feels normal. This should also be done after washing or starting in very damp or cold weather.

Severe strain on the brake system

The brakes will be subject to severe strain when driving in mountains or hilly areas or towing. The speed is usually low which means that the cooling of the brakes is less efficient than when driving on level roads. To reduce the strain on the brakes, it is advisable not to use the brakes excessively. Instead, shift into a lower gear, position 3 or in some cases, L (automatic transmission) and let the engine help with the braking. Do not forget that, if you are towing a trailer, the brakes will be subjected to greater load than is normal.

If the brake power-assist does not function

The power assist to the brakes functions only when the engine is running. When the car is moving without the engine running the brake pedal pressure required to stop the car is increased by 3-4 times and the brake pedal feels stiff.



[Contents](#) | [Top of Page](#)

When preparing for trailer towing, observe the following:

NOTE: Models with automatic transmission are equipped with a transmission oil cooler as standard equipment. This cooler helps prevent overheating of the transmission during times of increased load, as when towing a trailer.

Maximum trailer weight recommended by Volvo is:

- **Trailers without brakes:** 1100 lbs (500kg)
- **Trailers with brakes:** 2" (50 mm) ball - 3300 lbs (1500 kg), 1 7/8" (47 mm) ball - 2000 lbs (908 kg).

Observe the legal requirements of the state/province in which the vehicles are registered. All Volvo models are equipped with energy-absorbing shock-mounted bumpers. Trailer hitch installation should not interfere with the proper operation of this bumper system.

Trailer towing does not normally present any particular problems, but take into consideration:

- Increase tire pressure to recommended full. [See section "Wheels and tires"](#).
- Recommended hitch tongue load is 110 (50 kg) for trailer weights below 2,650 lbs (1,200 kg) and 165 lbs (75 kg) for trailer weights above 2,650 lbs (1,200 kg). For trailer weights between 2,650 - 3,300 lbs (1,200 - 1,500 kg) a top speed of 50 mph (80 km/h) should never be exceeded.
- Engine and transmission are subject to increased loads. Therefore, engine coolant temperature should be closely watched when driving in hot climates or hilly terrain. Use lower gear and turn off air conditioner if the temperature gauge pointer enters the red range.
- Avoid overload and other abusive operation.
- Hauling a trailer affects handling, durability, and economy.
- It is necessary to balance trailer brakes with the towing vehicle brakes to provide a safe stop (check and observe State/Local regulations).
- Do not connect the trailer's brake system directly to the vehicle's brake system.
- More frequent vehicle maintenance is required.
- Remove the ball and drawbar assembly when the hitch is not being used.
- Volvo recommends the use of synthetic engine oil when towing a trailer over long distances or in mountainous areas.

NOTE: [Refer to section "Automatic transmission" for additional trailer hauling tips.](#)

WARNING!

- Bumper-attached trailer hitches must not be used on Volvos, nor should safety chains be attached to the bumper.
- Trailer hitches attaching to the vehicle rear axle must not be used.
- Never connect a trailer's hydraulic brake system directly to the vehicle brake system, nor a trailer's lighting system directly to the vehicle lighting system. Consult your nearest authorized Volvo retailer for correct installation.
- When towing a trailer, the trailer's safety wire must be correctly fastened to the hole or hook provided in the trailer hitch on the car. The safety wire should never be fastened to or wound around the drawbar ball.

Consult your Volvo retailer for information on approved trailer hitches.

pg. 74 Winter driving

Cold weather precautions

If you wish to check your car before the approach of cold weather, the following advice is worth noting:

- Make sure that the **engine coolant** contains at least 50 percent antifreeze: that is, 3.7 qts. (3.5 liters) Volvo Genuine Coolant/Antifreeze. This gives protection against freezing down to -31°F (-35°C). [See section "Coolant"](#). **The use of "recycled" antifreeze is not approved by Volvo. Different types of antifreeze may not be mixed.**
- Try to keep the **fuel tank** well filled - this prevents the formation of condensation in the tank. In addition, in extremely cold weather conditions it is worthwhile to add fuel line de-icer before refueling.
- The viscosity of the engine oil is important. Oil with low viscosity (thinner oil) improves cold-weather starting as well as decreasing fuel consumption while the engine is warming up. For winter use, 5W-30 oil, particularly the synthetic type, is recommended. Be sure to use good quality oil but do not use this cold-weather oil for hard driving or in warm weather. [See section "Engine oil" for more information.](#)
- The load placed on **the battery** is greater during the winter since the windshield wipers, lighting, etc. are used more often. Moreover, the capacity of the battery decreases as the temperature drops. In very cold weather, a poorly charged battery can freeze and be damaged. It is therefore advisable to check the state of charge more frequently and spray an anti-rust oil on the battery posts.
- Volvo recommends the use of snow tires on all four wheels for winter driving - [see section "Wheels and tires"](#).
- To prevent the **washer fluid reservoir** from freezing, add washer solvents containing antifreeze ([see page 123 for the location of the washer fluid reservoir](#)). This is important since the dirt is often splashed on the windshield during winter driving, requiring the frequent use of the washers and wipers. The Volvo Washer Solvent should be diluted as follows:

Down to 14°F (-10°C): 1 part anti-freeze and 4 parts water

Down to 5°F (-15°C): 1 part anti-freeze and 3 parts water

Down to 0°F (-18°C): 1 part anti-freeze and 2 parts water

Down to -18°F (-28°): 1 part anti-freeze and 1 part water

- Use Volvo Teflon Lock Spray in the locks.

NOTE: Avoid the use of de-icing sprays as they can cause damage to the locks.

W Winter/Wet mode

Enhanced Vehicle Traction

This mode may be selected for starting/moving off on slippery roads.

In this mode:

- In position D*, the gearbox starts in 3rd gear and changes up to 4th gear.
- In position 3*, 2nd gear is locked and there is no change up to 3rd gear.
- In position L, 1st gear is locked.

* These positions always offer the kick-down function.

pg. 75 Storing the car for extended periods, Long distance trips

Storing the car for extended periods

If you do not intend to drive your car for an extended period, e.g., during the winter, please keep the following points in mind to help avoid problems when you want to drive the car again:

- Fill the fuel tank to avoid condensation in the tank.
- Park the car in a dry, well-ventilated garage.
- The parking brake should not be applied. Place the gear selector in Park position (automatic transmission) or in reverse (manual transmission).
- Raise the convertible top.
- Fold out the windshield and headlight wipers so that the rubber blades do not stick to the glass.
- Open one of the windows slightly to allow for ventilation in the passenger compartment.
- Check the battery's charge approximately once every six weeks.

Before a long distance trip

It is always worthwhile to have your car checked at a Volvo retailer before driving long distances. Your retailer will also be able to supply you with bulbs, fuses, spark plugs and wiper blades for your use in the event that problems occur.

If you prefer to check the car yourself, please note the following:

- Check that the engine runs smoothly and that fuel consumption is normal.
- Check engine oil, coolant levels, and for possible fuel leakage.

- Check transmission oil level.
- Check condition of drive belts.
- Check state of charge of battery.
- Examine tires carefully (the spare tire as well), and replace those that are worn. Check tire pressures.
- The brakes, front wheel alignment, and steering gear should be checked by your Volvo retailer only.
- Check all lights, including high beams.
- Reflective warning triangles are legal requirement in some countries.
- Have a word with your Volvo retailer concerning engine adjustments if you intend to drive in countries where it may be difficult to obtain correct fuel.
- Consider your destination. If you will be driving through an area where snow or ice are likely to occur, consider snow tires.



[Contents](#) | [Top of Page](#)

Chapter 5 - Wheels and tires

pg. 77 Wheels and tires

Wheels and tires

The handling and riding comfort of the vehicle is dependent on the inflation pressure and the type of tires fitted. Read the following pages carefully.

[General information, Wear indicator, Tire economy, Flat spots](#) [78](#)

[Snow chains, Winter tires](#) [79](#)

[Inflation pressure](#) [80](#)

[Uniform tire quality grading](#) [81](#)

pg. 78 Wheels and tires

General information

Your vehicle is equipped with tires according to the tire information label located on the rear facing side of the right front door.

The following is an **example** of a tire designation code 225/50R16:

225 = tire width in mm.

50 = tire profile. This is the relationship (in percent) between the section height and the width of the tire.

R = radial tires.

16 = diameter in inches.

The tires have good road holding characteristics and offer good handling on dry and wet surfaces. It should be noted however that the tires have been developed to give these features on snow/ice-free surfaces. **Certain models are equipped with "all-season" tires, which provide a somewhat higher degree of winter roadholding on slippery surfaces than tires without the "all-season" rating.** However, for optimum road holding on icy or snow covered roads - **we recommend suitable winter tires on all four wheels.** When replacing tires, be sure that the new tires are the same size designation, type (radial) and preferably from the same manufacturer, on all four wheels. Otherwise there is a risk of altering the car's road-holding and handling characteristics.

NOTE: When storing wheel/tire assemblies (e.g. winter tires and wheels), either stand the assemblies upright or suspend them off the ground. Laying wheel/tire assemblies on their sides for prolonged periods can cause wheel and/or tire damage.

Wear indicator

The tires have a so-called "wear indicator" in the form of a number of narrow strips running across or parallel to the tread. When approx. 1/16" (1.6 mm) is left on the tread, these strips show up and indicate that the tire should be replaced.

Tires with less than 1/16" (1.6 mm) tread have a very poor grip in rain or snow.

When replacing worn tires, it is recommended that the tire be identical in type (radial) and size as the one being replaced. Using a tire of the same make (manufacturer) will prevent alteration of the driving characteristics of the vehicle.

To improve tire economy:

- Maintain correct tire pressure.
- Drive smoothly: avoid fast starts, hard braking and tire screeching.
- Tire wear increases with speed.
- Correct front wheel alignment is very important.
- Unbalanced wheels impair tire economy and driving comfort.
- If the wheels are rotated, they should be kept on the same side of the car so that they revolve in the same direction as prior to rotation.
- Hitting curbs or potholes can damage the tires and/or wheels permanently.

Flat spots

All tires become warm during use. After cooling, when the vehicle is parked, the tires have a tendency to distort slightly, forming flat spots. These flat spots can cause vibrations similar to the vibrations caused by unbalanced wheels. They do, however, disappear when the tire warms up. The degree to which the flat spots form depends on the type of cord used in the tire. Remember that, in cold weather, it takes longer for the tire to warm up and consequently longer for the flat spot to disappear.

CAUTION: The car must not be driven with wheels of different dimensions. The use of different size wheels can seriously damage your car's transmission.

pg. 79 Wheels and tires (cont.)

Snow chains

Snow tire chains can be used on your Volvo with the following restrictions:

- Snow chains should be installed on front wheels only. Use only Volvo approved snow chains.
- Snow chains may be mounted on tire dimension 195/65R15. Tire dimension 205/55R16 requires a special type of snow chain. Consult your Volvo retailer. Snow chains may not be used on 205/55R16 tires.

If accessory, aftermarket or "custom" tires and wheels are installed and are of a size different than the

original tires and wheels, chains in some cases CANNOT be used. Snow chains cannot be used on those turbo-charged models fitted with all-season tires 225/50R16 or 225/45R17 or 225/40R18. Sufficient clearances between chains and brakes, suspension and body components must be maintained.

- Some strap-on type chains will interfere with brake components and therefore CANNOT be used.

Consult your Volvo retailer for additional snow chain information.

CAUTION:

- Check local regulations regarding the use of snow chains before installing.
- Always follow the chains manufacturer's installation instructions carefully. Install chains as tightly as possible and re-tighten periodically.
- Never exceed the chain manufacture's specified maximum speed limit. (Under no circumstances should that limit be higher than 30 mph (45 km/h)).
- Avoid bumps, holes or sharp turns when driving with snow chains.
- The handling of the vehicle can be adversely affected when driving with chains. Avoid fast or sharp turns as well as locked wheel braking.

Snow tires, studded tires *

Tires for winter use:

Owners who live in or regularly commute through areas with sustained periods of snow or icy driving conditions are strongly advised to fit suitable winter tires to help retain the highest degree of traction.

It is important to install winter tires **on all four wheels** to help retain traction during cornering, braking and accelerating. Failure to do so could reduce traction to an unsafe level or adversely affect handling. Do not mix tires of different design as this could also negatively affect overall tire road grip. **Volvo recommends 195/65 R15 winter tires on 15" steel wheels on all C 70 models including those equipped with 16", 17" or 18" wheels.**

Winter tires wear more quickly on dry roads in warm weather. They should be removed when the winter driving season has ended.

Studded tires should be run-in 300-600 miles (500-1000 km) during which the car should be driven as smoothly as possible to give the studs the opportunity to seat properly in the tires. The car tires should have the same rotational direction throughout their entire lifetime. In other words, if you wish to rotate the wheels, make sure that the same wheels are always on the same side of the car.

NOTE: Please consult state or local regulations restricting the use of studded winter tires before installing such tires.

* Where permitted

pg. 80 Wheels and tires (cont.)

Checking and correcting tire pressure

- Check the tire pressure when refueling.
- The tire pressure should be corrected only when the tires are cold.
- With warm tires, correct only when the pressure is too low. The tire temperature rises after driving just a few miles.

Vehicle Loading

The tires on your Volvo will perform to specifications at all normal loads when inflated as recommended on the tire information label* located on the rear facing edge of the passenger's door. This label lists both the tire and vehicle design limits.

Do not load your car beyond the load limits indicated.

* Please note that the tire information label indicates pressures for both comfort and fuel economy.

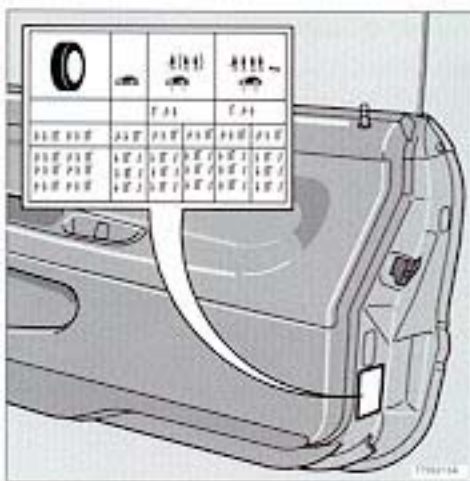

Tire pressure label

pg. 81 Wheels and tires (cont.)

Uniform tire quality grading

ALL PASSENGER CAR TIRES MUST CONFORM TO FEDERAL SAFETY REQUIREMENTS IN ADDITION TO THESE GRADES

TREADWEAR

The treadwear grade is a comparative rating based on the wear rate of the tire when tested under controlled conditions on a specified government test course. For example, a tire graded at 150 would wear one and one half (1 1/2) times as well on the government course as a tire graded 100. The relative performance of tires depends upon the actual conditions of their use, however, and many depart significantly from the norm due to variation in driving habits, service practices and differences in road characteristics and climate.

TRACTION

The traction grades, from highest to lowest, are AA, A, B, and C, as measured under controlled conditions on specified government test surfaces of asphalt and concrete. A tire marked C may have poor traction performance.

WARNING! The traction grade assigned to this tire is based on braking (straight-ahead) traction tests and does not include cornering (turning) traction.

TEMPERATURE

The temperature grades are AA (the highest), A, B, and C, representing the tire's resistance to the generation of heat and its ability to dissipate heat when tested under controlled conditions on a specified indoor laboratory test wheel. Sustained high temperature can cause the material of the tire to degenerate and reduce tire life, and excessive temperature can lead to sudden tire failure. The grade C corresponds to a level of performance which all passenger car tires must meet under the Federal Motor Safety Standard No. 109. Grades B and A represent higher levels of performance on the laboratory test wheel than the minimum required by law.

WARNING! The temperature grade for this tire is established for a tire that is properly inflated and not overloaded. Excessive speed, underinflation, or excessive loading, either separately or in combination, can cause heat buildup and possible tire failure.



[Contents](#) | [Top of Page](#)

Chapter 6 - In case of emergency

pg. 83 In case of an emergency

In case of an emergency

Even if you maintain your car in good running condition, there is always the possibility that something might go wrong and prevent you from driving, such as a punctured tire, blown fuse or bulb, etc. For additional information, see section "ON CALL Road Assistance".

Wheel changing 84-85

Spare tire 86

Replacing bulbs 87-92

Replacing fuses 93-95

Installation of accessories 96

Replacing wiper blades 97-98

In case of emergency 99

pg. 84 Wheel changing

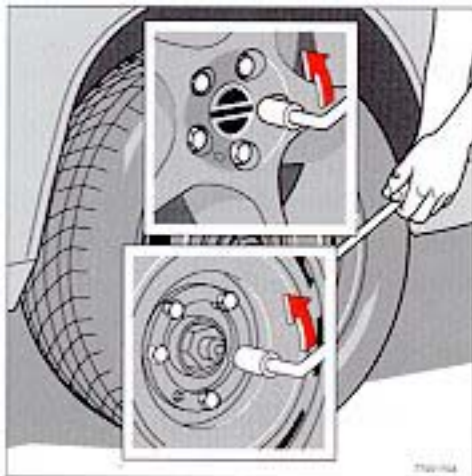

Loosen wheel bolts

Changing a wheel

The spare wheel is located under the carpet on the trunk floor. The jack and crank are secured in the wheel recess.

- Engage the parking brake.
- Put the gear selector in (P)ark (automatic) or in Reverse (manual).
- With the car still on the ground, use the lug wrench to loosen the wheel bolts 1/2 - 1 turn. Turn the bolts counterclockwise to loosen.
- Fold out the crank handle on the jack by pressing the nob on the handle downward. To attach the jack, refer to the illustration on the following page.

CAUTION:

- The car must not be driven with wheels of different dimensions or with a spare tire other than the one that came with the car. The use of different size wheels can seriously damage your car's transmission.

NOTE: To avoid excessive wear and the necessity of rebalancing, mark and reinstall wheels in same location and position as before removal. To lessen the chance of imbalance, each wheel hub is equipped with a guide stud to ensure that a removed wheel can be reinstalled in its original position (as when changing over to winter tires/wheels).

pg. 85 Wheel changing (cont.)



Jack attachment

There is a jack attachment located in the center on each side of the car. Position the jack on the bar in the attachment as shown in illustration A above and crank while simultaneously guiding the base of the jack to the ground. **The base of the jack must be flat on a level, firm, non-slippery surface. Before raising the car check that the jack is still correctly positioned in the attachment.** Raise the vehicle until both wheels on the side of the car where the jack is attached are lifted off the ground. Unscrew the wheel bolts completely and carefully remove the wheel so as not to damage the thread on the studs.

Installing the wheel

Clean the contact surfaces on the wheel and hub. Lift the wheel and place it on the hub. Make sure that you align the wheel with the guide stud on the wheel hub prior to installation. Install the wheel bolts crosswise (see illustration) and tighten by turning lightly clockwise. Lower the vehicle to the ground and alternately tighten the nuts to 81 ft. lbs. (110 Nm). Install the wheel cap (where applicable).

CAUTION: Correct tightening torque on wheel bolts must be observed. The wheel bolts should never be greased or lubricated. The extended, chromed wheel bolts must not be used with steel rims, as they make it impossible to fit the hub caps.



Correct tightening order for wheel bolts

WARNING!

- The jack's attachment must engage the bar in the jack attachment (A). The car's weight must not rest on the jack's attachment (B).
- Be sure the jack is on a firm, level, non-slippery surface.
- Never allow any part of your body to be extended under a car supported by a jack.
- Use the jack intended for the car when replacing a wheel. For any other job, use stands to support the end of the car being worked on.
- Apply the parking brake, select position P (automatic transmission) or Reverse gear (manual transmission).
- Block the wheels standing on the ground, use rigid wooden blocks or large stones.
- The jack should be kept well-greased.

pg. 86 Spare tire



Temporary Spare (certain models)

The spare tire of your car is what is called a "Temporary Spare". It has the following designation: T115/70 R15 or T125/90R15.

Recommended tire pressure (see decal on fuel filler flap) should be maintained irrespective of which position on the car the Temporary Spare tire is used on.

In the event of damage to this tire a new one can be purchased from your Volvo retailer.

CAUTION: The car must not be driven with wheels of different dimensions or with a spare tire other than the one that came with the car. The use of different size wheels can seriously damage your car's transmission.

WARNING!

Current legislation prohibits the use of the "Temporary Spare" tire other than as a temporary replacement for a punctured tire. In other words, it must be replaced as soon as possible by a standard tire. Roadholding, etc., may be affected with the "Temporary Spare" in use. Do not, therefore, exceed 50 mph (80 km/h).



[Contents](#) | [Top of Page](#)

pg. 87 Replacing bulbs

Replacing bulbs

Make sure when installing bulbs, that the guide pin on the socket fits into its corresponding recess. When installing Halogen bulbs, do not touch the glass with your fingers since grease, oil or any other impurities can be carbonized onto the bulb and damage the reflector. Use bulbs of correct type and voltage. Failure to do so could cause the bulb failure warning light to activate.

NOTE: Turn the ignition and the light switch off before replacing any bulbs.

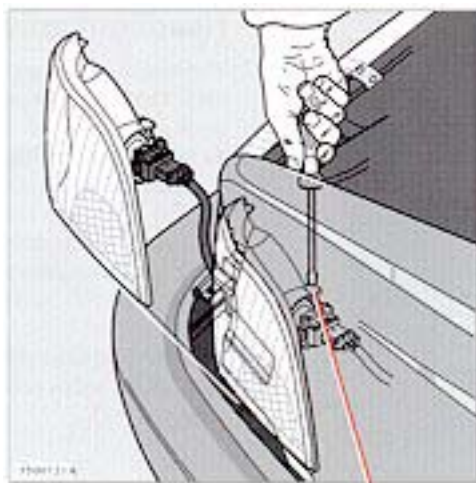

Catch

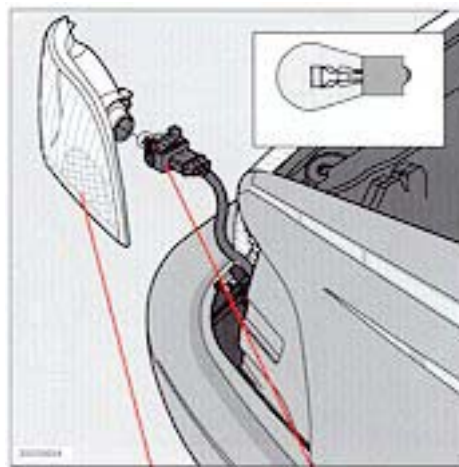

*Lamp housing, Bulb holder
Bulb-3357NA, 26/7W/30/2.2 cp*

Parking light/direction indicator

1. From the front of the car, use a screwdriver to press down on the silver catch (located in the space between the inside of the fender and the headlight unit) to release the lamp housing from the front fender.
2. Turn the bulb holder 1/4 turn clockwise (viewed from the front) and withdraw it from the lamp housing. Leave the connector with its wires in the bulb holder.
4. Remove the bulb from the holder by pulling it straight out.
5. Press a new bulb into the holder and reinstall the unit in the reverse order.

pg. 88 Replacing bulbs (cont.)

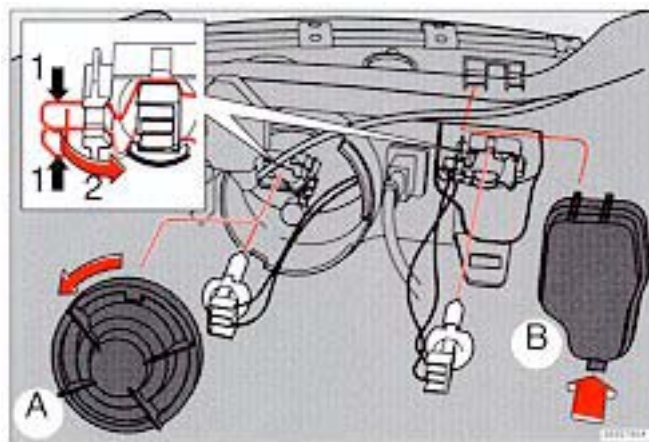

A- Low beam Bulbs (high and low beams) - H7 B- High beam

Low beam headlight bulb (A) replacement

1. Turn the plastic cover counter-clockwise and remove it.
2. Press the wire catches on the retaining clamp (1 in insert illustration above) together and push out (2) to release the bulb and connector from the headlight housing.
3. Pull the bulb out of the connector.
4. Insert a new bulb into the connector.
5. Re-insert the bulb and connector into the headlight housing. The guide lug must be *up* to ensure proper position.
6. Press the retaining clamp back into position.
7. Reinstall the plastic cover.

Headlight adjustment

The height of the headlight beams can be adjusted according to vehicle load. The headlights should be re-aimed if heavy loads are carried in the trunk/cargo area or rear seat, or when towing a trailer.

To adjust the headlights:

- Park the car on a level surface and open the hood.
- The headlights are equipped with a level which can be seen by looking through the clear "window" on the top of the headlight lens.
- Turn the height adjustment knob until the bubble in the level aligns with the "0" marks or within the dark marking lines.

Lateral headlight adjustment should only be carried out by an authorized Volvo retailer. The lateral adjustment scale (B) should be preset to "0".

High beam headlight bulb (B) replacement

1. Pull the catch on the lower edge of the cover upward and remove the plastic cover.
2. Press the wire catches on the retaining clamp (1 in insert illustration above) together and push out (2) to release the bulb and connector from the headlight housing.
3. Pull the bulb out of the connector.
4. Insert a new bulb into the connector.
5. Re-insert the bulb and connector into the headlight housing. The guide lug must be *up* to ensure

proper position.

6. Press the retaining clamp back into position.

7. Reinstall the plastic cover. Catch B should snap into position.

pg. 89 Replacing bulbs (cont.)

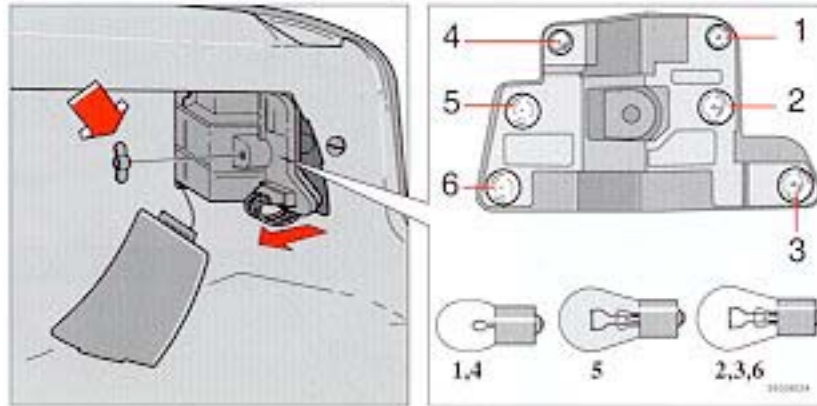

Lamp location- right side
(in trunk)

Lamp location - right
side (in trunk lid)

Tail light bulbs

1. Tail light
2. Direction indicator
3. Brake light
4. Tail light
5. Back-up light
6. Rear fog light (left side only)

All the bulbs in the tail light unit are replaced from inside the trunk as follows:

1. Turn the two plastic screws and open the cover over the rear lamp unit in the trunk (or depress the catch on the cover on the trunk lid).
2. Press catch A or B and remove the bulb holder.
3. Let the connector with its wires remain attached to the bulb holder.
4. Remove the bulb by pressing in and turning counter-clockwise.
5. Insert a new bulb into the holder and reinstall the holder into the tail light assembly.
6. Close the cover.

Bulbs 1, 4:
5W/4 cp BA 15s

Bulb 2:
21W BAU 15 s (amber)

Bulb 3,5,6:

pg. 90 Replacing bulbs (cont.)

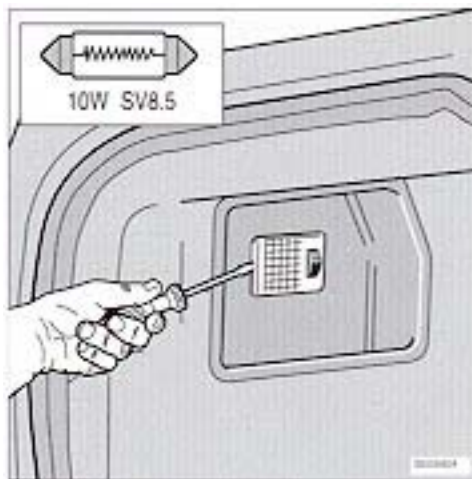

Insert screwdriver and turn

Trunk light

- Switch off the lights.
- Press in the catch with a screwdriver and remove the bulb holder.
- Replace the bulb and reinstall the bulb holder.



License plate lights

- Switch off the lights
- Unscrew the screw
- Insert the screwdriver and turn gently to loosen the glass lens
- Replace the bulb and reinstall the glass lens

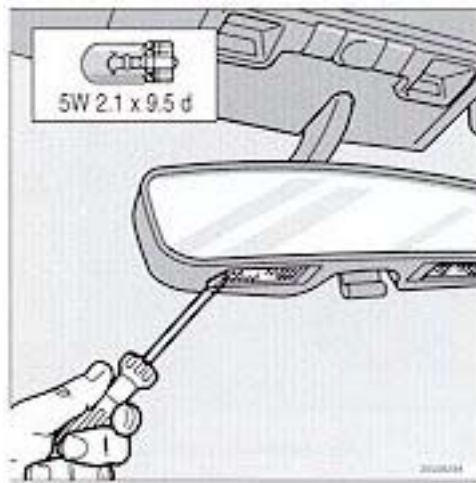

Insert screwdriver, turn and pull downward

Front courtesy lights

- Switch off the ignition.
- Insert a screwdriver and turn carefully to loosen the glass lens.
- Replace the bulb and press the glass lens back into place.

pg. 91 Replacing bulbs (cont.)

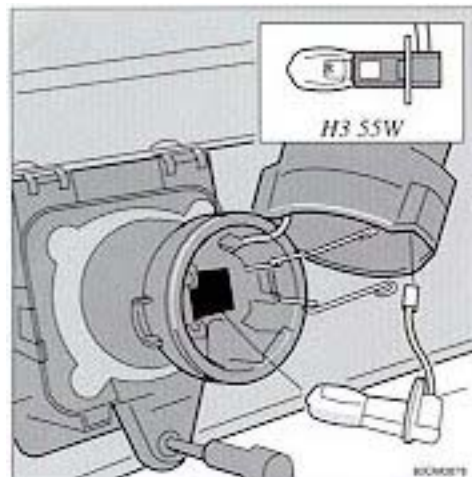

Front fog lights in spoiler

Front fog lights

- Switch off the ignition.
- Insert a screwdriver and turn to loosen the lamp unit.
- Replace the bulb and press the lamp unit back into place.

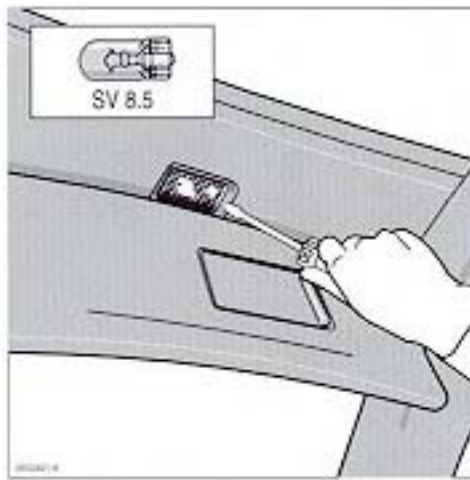

Insert a screwdriver and turn

Vanity mirror

- Switch off the ignition.
- Insert a screwdriver under the lower edge and turn to loosen the glass lens.
- Push out the bulb and replace it.
- Press the lower edge of the lens into place above the four catches.
- Press the upper edge of the lens into place.

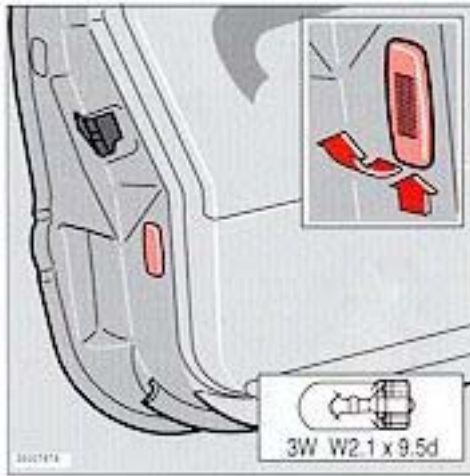

Slide upward and pull out lower edge

Door warning lights

Front

- Slide the lamp unit upward and pull out the lower edge.
- Twist off the bulb holder.
- Pull the bulb straight out.
- Replace the bulb.
- Reinstall the holder and lamp unit in reverse order.



Insert a screwdriver

Door step courtesy lights

- Insert a screwdriver and pry out the glass lens.
- Withdraw the lamp unit, bend back the tabs and remove the plate.
- Replace the bulb.
- Reinstall the plate.
- Press the lamp unit back into place.

NOTE: Other bulbs may be difficult for the owner to replace. Let your Volvo retailer replace these bulbs if necessary.



[Contents](#) | [Top of Page](#)

pg. 93 Replacing fuses

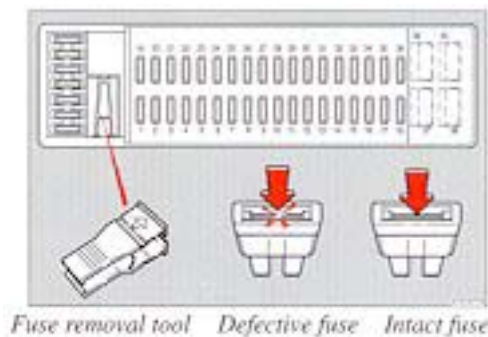
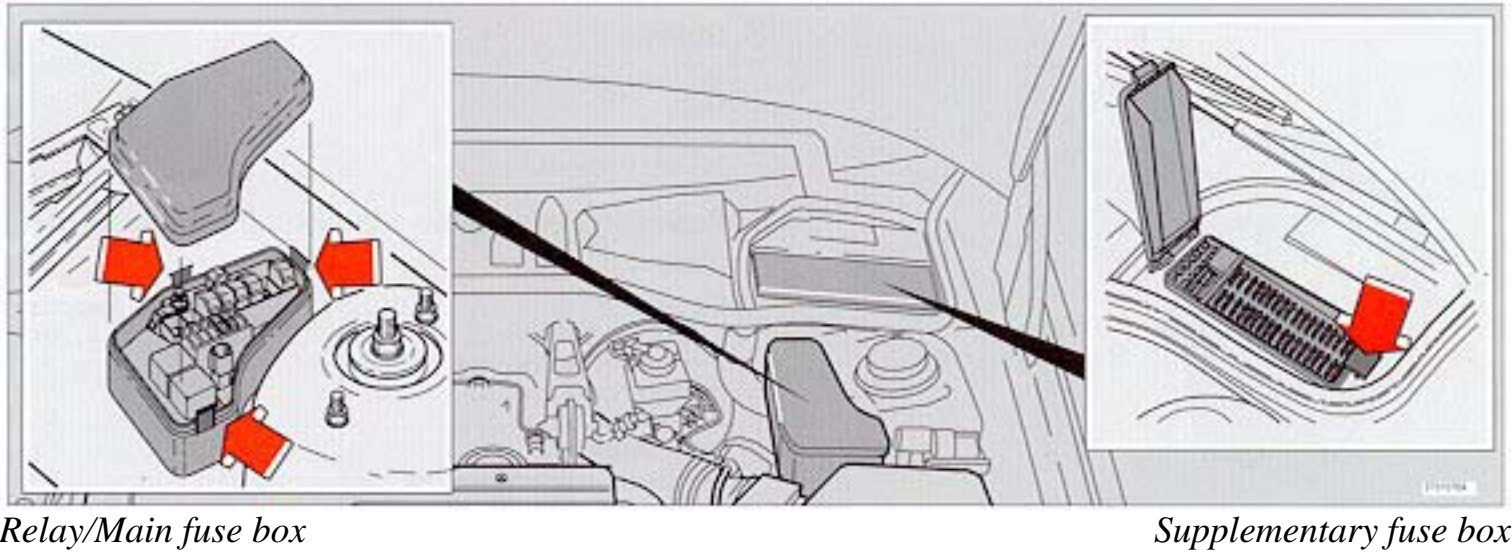
**Replacing fuses**

If an electrical component fails to function, it is likely that a fuse has blown due to a temporary circuit overload.

The fuse box is located in the engine compartment (see illustration) and can be opened by lifting the cover (Relay/Main fuse box) or by lifting the cover (supplementary fuse box). A label on the inside of the cover indicates the amperage and the electrical components that are connected to each fuse. The easiest way to see if a fuse is blown is to remove it.* Pull the fuse straight out. From the side, examine the curved metal wire to see if it is broken. If so, put in a new fuse of the same color and amperage (written on the fuse). Spare fuses are stored in a compartment in the fuse box. If fuses burn out repeatedly, have the electrical system tested at a Volvo retailer. If you find it difficult to remove a fuse, you will find a special fuse tool clipped in the fuse box.

* Fuses in the Relay/Main fuse box should only be changed by an authorized Volvo service technician.

pg. 94 Fuses

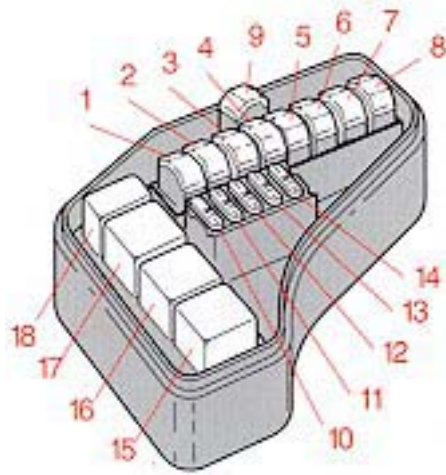

Relay/Main fuse box

Fuses in the main fuse box protect the entire electrical system. If one of the fuses blows, there is a serious electrical fault. Do not change any of these fuses. Contact your nearest Volvo workshop for a closer analysis.

Relays

15 System relay

16 -

17 Starter motor

18 Air conditioning

Fuses in Relay/Main fuse box (main system fuses)

Location *	Amperage
1 Electric cooling fan	60 A
2 Fuses in Supplementary fuse box	50 A
3 Starter motor	50 A
4 ABS	50 A
5 Headlights	50 A
6 Fuses in Supplementary fuse box	60 A
7 Fuses in Supplementary fuse box	60 A
8 Control modules - engine/automatic transmission	60 A
9 Power windows	60 A
10 Ignition switch, Control modules - engine/automatic transmission	10 A
11 Fuel injectors, engine controls	10 A
12 Fuel pump	20 A

13 Control module - automatic transmission	10 A
14 A/C relay, emissions systems	10 A

* Some of the equipment/systems listed may be available on certain models only.

pg. 95 Fuses (supplementary fuse box)

Location*	Amperage
1 Trunk open switch solenoid	10A
2 Central locking, driving mode selectors (aut. trans.)	10 A
3 ABS	10 A
4 -	
5 Climate systems, Onboard diagnostics OBDII	15 A
6 Central locking system	20 A
7 Audio system	15 A
8 Instrument panel, headlight switch	15 A
9 Amplifier - audio system	30 A
10 Ignition switch	15 A
11 Brake lights	10 A
12 Amplifier - audio system	30 A
13 Hazard warning flashers, headlight flashers, remote operated central locking system	15 A
14 Heated rear window and door mirrors	40 A
15 Courtesy lights, door open warning lights, trunk light, seat belt reminder, glove compartment light	10 A
16 Power antenna, electrical connector for trailer, accessories, CD-changer (option)	30 A
17 Front fog lights	20 A
18 Key reminder	10 A
19 Left high beam, accessories	15 A
20 Right high beam, high beam indicator light	15 A
21 Left low beam	15 A
22 Right low beam	15 A

23 Parking lights, tail lights, license plate lights	10 A
24 Parking lights, tail lights	10 A
25 Rear fog light, rear fog light indicator lamp	10 A
26 Headlight switch	15 A
27 Backup lights, turn signals	15 A
28 Heated front seats (certain models)	25 A
29 Heated rear window/door mirrors, shiftlock, seat belt reminder, cruise control, bulb failure warning sensor, electrical connector for trailer	10 A
30 12-volt auxiliary socket	15A
32 Audio system, convertible top, power antenna/trunk lid cutoff	10 A
33 -	
34 Windshield headlight wipers/washers, horn	25 A
35 Instrument lighting, accessories, convertible top chime, power windows/mirrors	10 A
36 12-volt auxiliary socket (rear), power seats	15 A
37 Power windows (passenger's side)	AUT/CB **
38 Power windows (driver's side)	AUT/CB **
39 Power seat (driver's side)	AUT/CB **
40 Power seat (passenger's side)	AUT/CB **
41 Electrically operated convertible top	AUT/CB **
42 Electrically operated convertible top	AUT/CB **

* Some of the equipment/systems listed may be available on certain models only.

** This is an automatic circuit breaker located in the fuse box and does not normally need to be replaced.

For more detailed information concerning function and location of relays, fuses, etc., refer to the Volvo Service Manuals. These can be purchased directly through your Volvo retailer.

pg. 96 Installation of accessories

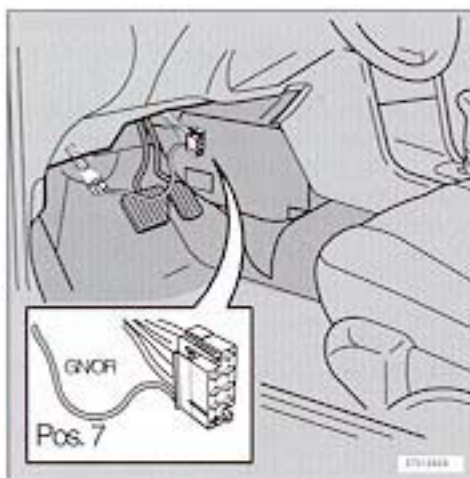

Installation of accessories

In order to help avoid interference and damage to your car's electrical system, your car is equipped with an accessory connector located under the instrument panel on the driver's side.

Please consult your Volvo retailer if you have any questions before connecting accessory or optional equipment to the vehicle's electrical system.

Connector (for accessories)

Position	Connection	Max. load
1	Battery + (30)	20 A
2	X Supply	0,5 A
3	High beam	1 A
4	-	1 A
5	-	1 A
6	Rheostat	0,5 A
7	-	2 A
8	Earth (31)	-



[Contents](#) | [Top of Page](#)

pg. 97 Replacing wiper blades

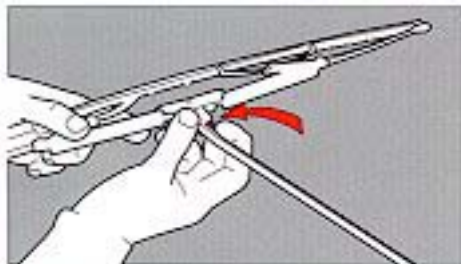

Replacing wiper blades

Lift the wiper arm off the windshield and hold the blade at right angles to the arm. Pinch the end of the plastic clip located at the back of the arm.

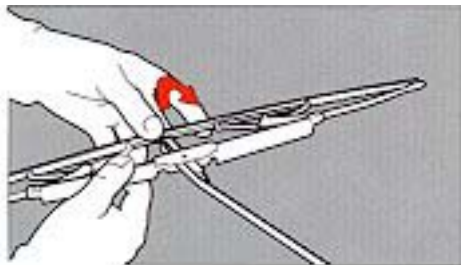

Slide the wiper blade along the arm to release it from the hook.

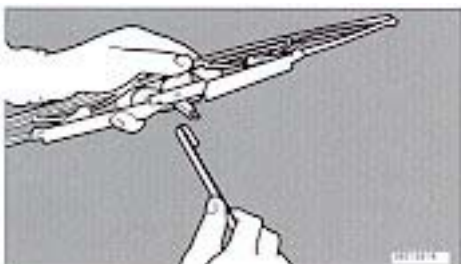

Install the new blade (installation is the reverse of removal) and make sure that it is properly attached to the wiper arm.

NOTE: For reasons of safety, you should change the windshield wiper blades as soon as they start to leave marks on the windshield or fail to wipe efficiently and cleanly.

To obtain maximum lifetime from a set of wiper blades, clean them with a stiff-bristle brush and warm, soapy water as part of a normal car wash.

Cleaning the outside of the windshield and wiper blades

If the windshield is not clear after using the wiper(s) or if the blade chatters when running, wax or other material may be on the blade or on the surface of the glass.

Clean the glass with a suitable cleaning agent. The glass is clean if beads do not form when you rinse it with water.

Clean the wiper blade by wiping vigorously with a cloth soaked in full strength windshield washer solvent. Then rinse the blade with water.

Wiper blades should be checked on a regular basis and replaced when worn.

pg. 98 Replacing headlight wiper blades

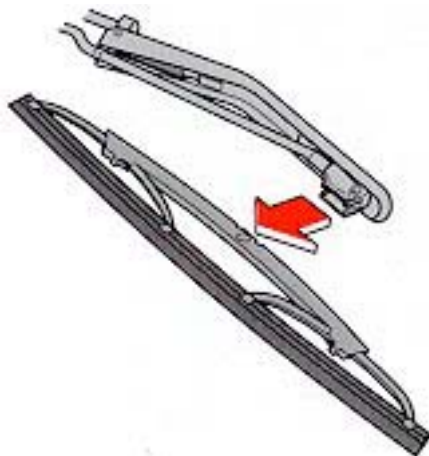

Replacing headlight wiper blades

Pull the wiper blade in the direction indicated by the arrow in the illustration to remove it. Press the new wiper into place. Check that the new blade is properly attached to the wiper arm.

pg. 99 In case of emergency



Shiftlock release (automatic transmission only)

The gear selector is locked in the (P)ark position. To manually release the shiftlock:

- Turn the starting (ignition) key to position I
- Press firmly on the "SHIFTLOCK OVERRIDE" button located to the right of the base of the gear selector
- While holding the override button down, press the button on the front of the gear selector
- Move the selector from the (P)ark position.

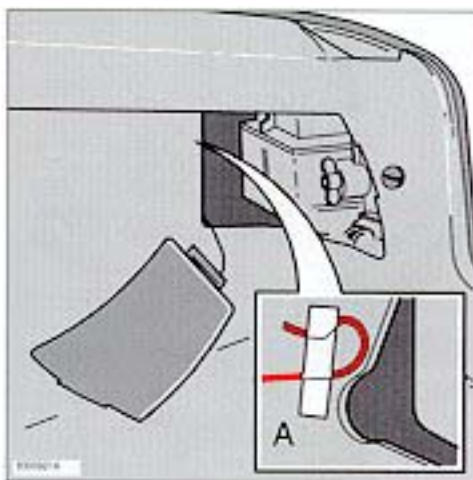

Manually opening the fuel tank cover

The fuel tank cover can be opened manually by removing the cover over the right tail light housing and pulling the wire (A) until the fuel tank cover opens.

pg. 100 In case of emergency

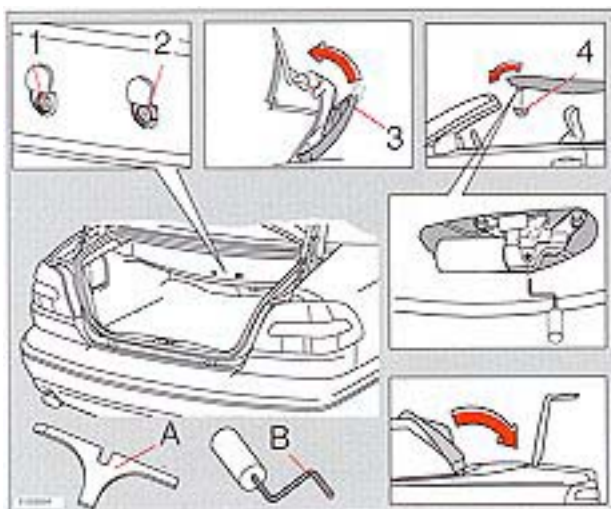

Manually raising the convertible top

NOTE: The tools needed (A and B in the illustration) are located in the glove compartment.

If it should be necessary to manually raise the convertible top:

- Open the trunk. The trunk must be open during the entire procedure.

Open the cover over the convertible top storage space

- Insert tool A in the right-hand hole (2) and turn it counterclockwise one complete turn.
- Insert tool B in the left-hand hole (1) and turn it counterclockwise until the cover over the convertible top storage space is completely open. This procedure could take several minutes.

Pull the convertible top forward

- Pull the convertible top forward to the upper edge of the windshield by pulling the rear brace (3).

- Remove the cover (4) by pulling it straight down. Pull the convertible top down onto the upper edge of the windshield and at the same time turn tool B clockwise (see inset illustration) until the convertible top seals properly with the upper edge of the windshield.

Close the cover over the convertible top storage compartment

- Insert tool B in the left-hand hole (1) and turn it clockwise until the cover over the convertible top storage compartment no longer moves. *The cover is not completely closed at this point.*
- Insert tool A in the right-hand hole (2) and turn it clockwise one complete turn. The cover is now locked in place.

Fold the rear window down

- Fold the rear window down and press it toward the attachment. At the same time, insert tool B in the left-hand hole (1) and turn it clockwise until the rear window is correctly in place.

NOTE: After manually raising the convertible top, the car should be inspected by an authorized Volvo retailer.

Circuit breaker

If the automatic circuit breakers have activated, wait at least 20 seconds before attempting to raise the top again using the switch on the instrument panel.

CAUTION: Do not attempt to service the convertible top motors, sensors or any moving parts yourself. This should only be done by an authorized Volvo retailer.



[Contents](#) | [Top of Page](#)

Chapter 7 - Car care

pg. 101 Car care

Car care

Car care includes not only maintaining the appearance of the car, but also protecting the car exterior from the effects of air pollution, rain, mud or road salt. The paintwork should also be touched up immediately, if damaged, to prevent rust formation.

Paint touch-up 102-103

Washing 104

Cleaning the convertible top, Polishing and waxing 105

Cleaning the upholstery 106

pg. 102 Paint touch-up

Paint touch-up

Paint damage requires immediate attention to avoid rusting. Make it a habit to check the finish regularly - when washing the car for instance. Touch up if necessary.

Paint repairs require special equipment and skill. Contact your Volvo retailer for any extensive damage.

Minor scratches can be repaired by using Volvo touch-up paint.

NOTE: When ordering touch-up paint from your Volvo retailer, use the paint code indicated on the model plate. The plate is located in the engine compartment, on the inside of the left front fender.



Minor stone chips and scratches

Material:

Primer - can

Paint - touch-up bottle

Brush

Masking tape

NOTE: When touching up the car, it should be clean and dry. The surface temperature should be above 60° F (15° C).

Scars on the surface

If the stone chip has not penetrated down to the metal and undamaged layer of paint remains, the touch-up paint can be applied as soon as the spot has been cleaned.

pg. 103 Paint touch-up (cont.)

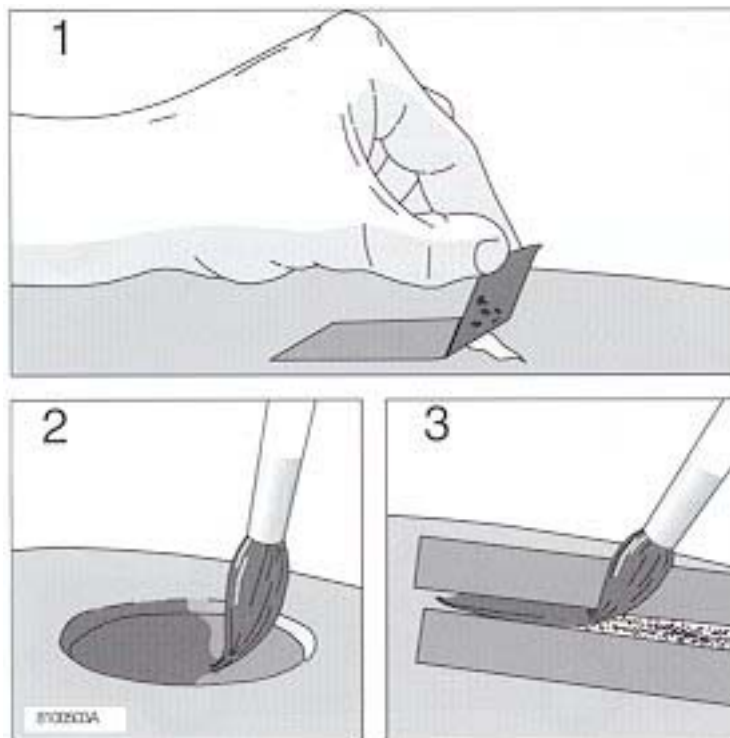

Deep scratches

1. Place a strip of masking tape over the damaged surface. Pull the tape off so that any loose flakes of paint adhere to it.
2. Thoroughly mix the primer and apply it with a small brush.
When the primer surface is dry, the paint can be applied using a brush. Mix the paint thoroughly; apply several thin paint coats and let dry after each application.
3. If there is a longer scratch, you may want to protect surrounding paint by masking it off.



[Contents](#) | [Top of Page](#)

Washing the car

- The car should be washed at regular intervals since dirt, dust, insects and tar spots adhere to the paint and may cause damage.
It is particularly important to wash the car frequently in the wintertime to prevent corrosion, when salt has been used on the roads.
- When washing the car, do not expose it to direct sunlight. Use lukewarm water to soften the dirt before you wash with a sponge, and plenty of water, to avoid scratching.
- **Bird droppings:** Remove from paintwork as soon as possible. Otherwise the finish may be permanently damaged.
- A detergent can be used to facilitate the softening of dirt and oil.
- A water-soluble grease solvent may be used in cases of sticky dirt. However, use a wash place equipped with a drainage separator.
- Dry the car with a clean chamois and remember to clean the drain holes in the doors and rocker panels.
- The power radio antenna (sedans) must be dried after washing.
- Tar spots can be removed with kerosene or tar remover after the car has been washed.
- A stiff-bristle brush and lukewarm soapy water can be used to clean the wiper blades. Frequent cleaning improves visibility considerably.
- Wash off the dirt from the underside (wheel housings fenders, etc.).
- In areas of high industrial fallout, more frequent washing is recommended.

CAUTION: During high pressure washing the spray mouthpiece must never be closer to the vehicle than 13" (30 cm). Do not spray directly into the locks, around the edges of the convertible top or the edges of the top's storage cove.

- When washing or steam cleaning the engine, avoid spraying water or steam directly on the electrical components or toward the rear side of the engine.
- After cleaning the engine, the spark plug wells should be inspected for water and blown dry if necessary.

Suitable detergents

Special car washing detergents or liquid dishwashing detergent can be used. A suitable mixture is about 2.5 fl. oz. (8.5 cl) of detergent to 2.6 US gal. (10 liters) of warm water. After washing with a detergent the car should be well rinsed with clean water.

WARNING!

- When the car is driven immediately after being washed, apply the brake several times in order to remove any moisture from the brake linings.
- Engine cleaning agents should not be used when the engine is warm. This constitutes a fire risk.

Bumpers: Wash the bumpers with the same cleaning agent used on the rest of the car. Never clean the bumpers with gasoline or paint thinner. Difficult spots can be removed with denatured alcohol. To avoid scratches, do not dry the bumpers with paper.

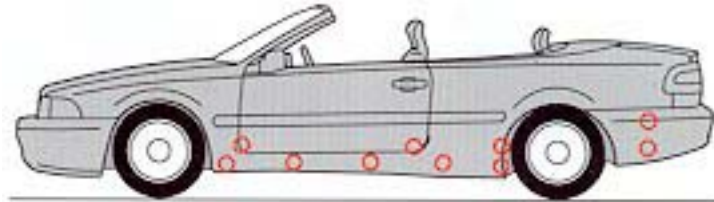

NOTE: When washing the car, remember to remove dirt from the drain holes in the doors and sills.

See your local Volvo retailer for a complete line of genuine Volvo environmental car care products.

* Pay special attention to the drain holes near the base of the windshield in the cowl under the rear edge of the hood.

pg. 105 Automatic car washing, Polishing and waxing

Cleaning the convertible top

CAUTION:

Some automatic car washes can damage the convertible top. For this reason, we recommend washing the car by hand only.

Remember that the windows are lowered slightly when the convertible top is raised. Be sure the windows are closed and the convertible top is completely raised and properly in place at the upper edge of the windshield before washing the car. A chime indicates when the top has been fully raised (see page 40).

- Wash the convertible top with a mild detergent, wiping from the front towards the rear. Rinse thoroughly with clean water.
- Do not wash the convertible top with a high pressure spray.
- After washing, the convertible top should be completely dry before it is folded down.
- Remove bird droppings from the convertible top as soon as possible. Otherwise the top may be permanently stained.

- A soft brush can be used to clean the convertible top between washings.
- Winter: remove any residue of road salt from the convertible top as soon as possible.
- Do not use solvents, tar remover or other all-purpose stain removers to clean the convertible top. Use Volvo approved cleaning agents only - consult your Volvo retailer.

Polishing and waxing

- Normally, polishing is not required during the first year after delivery, however, waxing may be beneficial.
- Before applying polish or wax the car must be washed and dried. Tar spots can be removed with kerosene or tar remover. Difficult spots may require a fine rubbing compound.
- After polishing use liquid or paste wax.
- Several commercially available products contain both polish and wax.
- Waxing alone does not substitute for polishing of a dull surface.
- A wide range of polymer-based car waxes can be purchased today. The waxes are easy to use and produce a long-lasting, high-gloss finish that protects the bodywork against oxidation, road dirt and fading.

Wax or polish should never be applied to the convertible top.

See your local Volvo retailer for a complete line of genuine Volvo environmental car care products.

pg. 106 Cleaning the upholstery

Cleaning the upholstery

The **fabric** can be cleaned with soapy water or a detergent. For more difficult spots caused by oil, ice cream, shoe polish, grease, etc., use a clothing/fabric stain remover.

The **plastic** in the upholstery can be cleaned with a soft cloth and mild soap solution.

Leather upholstery can be cleaned with a soft cloth and mild soap solution. For more different spots, Volvo offers a leather care kit.

On no account must gasoline, naphtha or similar cleaning agents be used on the plastic or the leather since these can cause damage.

Cleaning the seat belts

Clean only with lukewarm water and mild soap solution.

Cleaning floor mats

The floor mats should be vacuumed or brushed clean regularly, especially during winter when they should be taken out for drying. Spots on textile mats can be removed with a mild detergent.

Bear in mind

- Take extra care when removing stains such as ink or lipstick since the coloring can spread.
- Use solvents sparingly. Too much solvent can damage the seat padding.
- Start from the outside of the stain and work toward the center.

See your local Volvo retailer for a complete line of genuine Volvo environmental car care products.



[Contents](#) | [Top of Page](#)

Chapter 8 - Volvo Service

pg. 107 Volvo Service

Service - an investment

An investment which will pay dividends in the form of improved reliability, durability, and resale value.

<u>Label information</u>	<u>108</u>
<u>Maintenance service, Warranty</u>	<u>109</u>
<u>Maintenance schedule</u>	<u>110-111</u>
<u>Servicing</u>	<u>112-113</u>
<u>Fuel/emissions systems</u>	<u>114</u>
<u>Lubrication</u>	<u>115</u>
<u>Engine oil</u>	<u>116-117</u>
<u>Power steering fluid, Brake/clutch system fluid reservoir</u>	<u>118</u>
<u>Automatic transmission fluid</u>	<u>119</u>
<u>Drive belt</u>	<u>120</u>
<u>Windshield washer nozzle, Washer fluid reservoir</u>	<u>121</u>
<u>Coolant</u>	<u>122</u>
<u>Engine compartment</u>	<u>123</u>
<u>Battery maintenance</u>	<u>124</u>

pg. 108 Label information

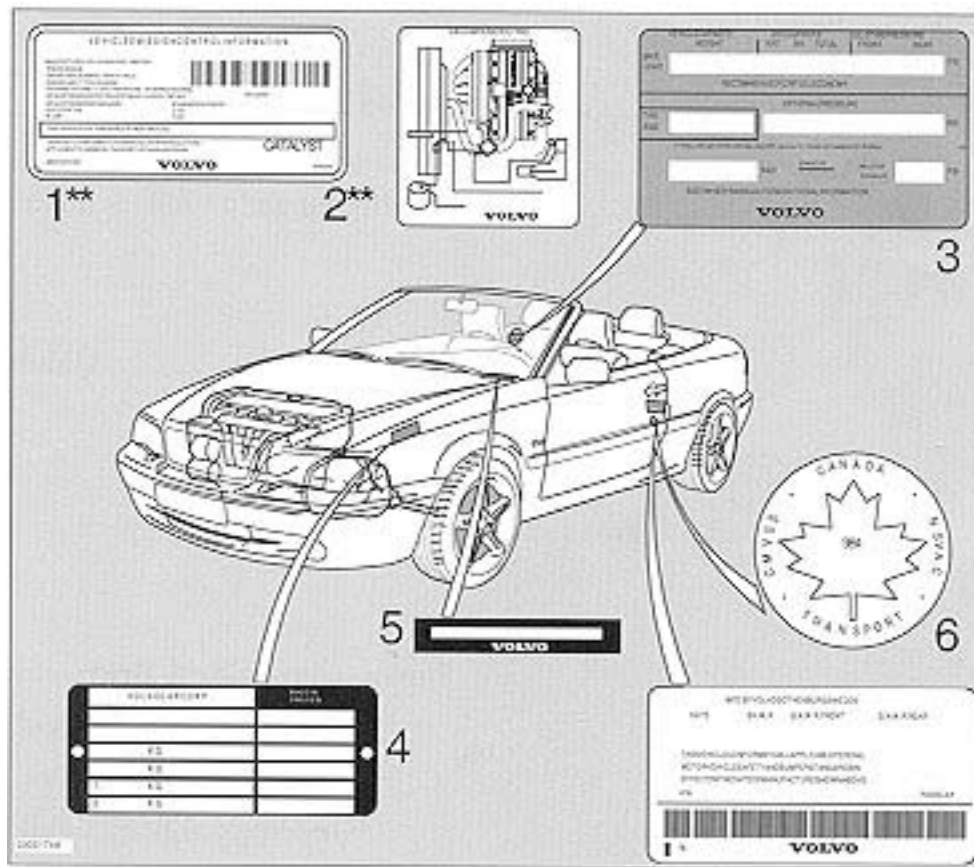

1 Vehicle Emission Control Information

Your Volvo is designed to meet all applicable emission standards, as evidenced by the certification label on the underside of the hood. For further information regarding these regulations, please consult your Volvo retailer.

2 Vacuum hose routing

(underside of hood)

3 Loads and Tire Pressures

(on rear edge of passenger's door)

4 Model plate

Vehicle Identification Number (VIN). Codes for color and upholstery, etc. The plate is located in the engine compartment, on the inside of left front fender.

5 Vehicle Identification Number (VIN) *

The VIN plate is located on the top left surface of the dashboard. The VIN is also stamped on the right hand door pillar.

6 Federal Motor Vehicle Safety Standards (FMVSS) specifications (USA) and Ministry of Transport (CMVSS) Standards (Canada)

Your Volvo is designed to meet all applicable safety standards, as evidenced by the certification label on the facing side of the driver's door. For further information regarding these regulations, please consult your Volvo retailer.

* The Vehicle Identification Number (VIN) should always be quoted in all correspondence concerning your vehicle with the retailer and when ordering parts.

** These decals are located on the underside of the hood.

All specifications are subject to change without notice.

pg. 109 Maintenance service, Warranty

Maintenance service

Volvo advises you to follow the service program which is outlined in the "Maintenance Records Manual". This maintenance program contains inspections and services necessary for the proper function of your car. The maintenance services contain several checks which require special instruments and tools and therefore must be performed by a qualified technician. To keep your Volvo in top condition, specify time tested and proven Genuine Volvo Parts and Accessories.

The Federal Clean Air Act - U.S.

The Clean Air Act requires vehicle manufacturers to furnish written instructions to the ultimate purchaser to assure the proper functioning of those components that control emissions. [The maintenance instructions listed in the "Servicing" section](#) of this Manual represent the minimum maintenance required. These services are not covered by the warranty. You will be required to pay for labor and material used. Refer to your Warranty booklet for further details.

Maintenance services

Your Volvo has passed several major inspections before being delivered to you, according to Volvo specifications. The maintenance services outlined in this book should be performed as indicated. The extended maintenance service intervals make it even more advisable to follow this program. Inspection and service should also be performed any time a malfunction is observed or suspected. It is recommended that receipts for vehicle emission services be retained in the event that questions arise concerning maintenance. See your "Maintenance Records Manual".

Applicable warranties - U.S.

In accordance with U.S. Federal Regulations, the following list of applicable U.S. warranties is provided. For Canadian specification vehicles, see your separate warranty booklet.

- New Car Limited Warranty
- Parts and Accessories Limited Warranty
- Corrosion Protection Limited Warranty
- Seatbelt and Supplemental Restraint Systems Limited Warranty
- Emission Design and Defect Warranty
- Emission Performance Warranty

These are the Federal warranties; other warranties are provided as required by state law. Refer to your separate Warranty booklet for detailed information concerning each of the warranties.

pg. 110 Maintenance schedule

Maintenance schedule

A = Adjust (Correct if necessary)

I = Inspect (Correct or Replace if necessary)

R = Replace

L = Lubricate

Maintenance Operation thousand miles (thousand km)	5 (8)	10 (16)	15 (25)	20 (32)	25 (40)	30 (48)	35 (56)	40 (64)	45 (72)	50 (80)	55 (88)	60 ² (96)
EMISSION SYSTEM MAINTENANCE												
Engine oil and filter ¹	R	R	R	R	R	R	R	R	R	R	R	R
Engine drive belt (accessory belt)						I						R
Air cleaner filter						R						R
Spark plugs						R						R
Automatic transmission fluid		I		I		I		I		I		I
Timing belt - all engines ³												

1) [See section "Engine oil" for detailed information](#)

NOTE: The oil should be changed at these intervals or after 750 hours of driving or after 12 months which ever occurs first. [See "Service Reminder indicator", page 19.](#)

2) For services beyond 60,000 miles (96,000 km), consult your "Maintenance Records booklet".

3) For proper functioning of the vehicle and its emission control system, Volvo **recommends** that the timing belt be replaced every 70,000 miles (112,000 km).

pg. 111 Maintenance schedule (cont.)

Maintenance schedule

A = Adjust (Correct if necessary)

I = Inspect (Correct or Replace if necessary)

R = Replace

L = Lubricate

Maintenance Operation	thousand miles	10	20	30	40	50	60
(thousand km)		(16)	(32)	(48)	(64)	(80)	(96)

ENGINE SYSTEM MAINTENANCE						
ENGINE						
Fuel (Line) Filter ¹						
PCV Nipple (orifice)/hoses,clean						I
Battery	I	I	I	I	I	I
BRAKES						
Inspect brakes, replace components as necessary	I	I	I	I	I	I
Brake Fluid ²						
STEERING/SUSPENSION						
Rotate tires/check wear (align front end if needed.)	I	I	I	I	I	I
Check power steering fluid level	I	I	I	I	I	I
Grease front link arm stops	L	L	L	L	L	L
BODY						
Power antenna (clean)	I	I	I	I	I	I
Trunk/hood, hinges and latches	L	L	L	L	L	L
Cabin air filter		R		R		R

1) Replace at 100,000 miles (160,000 km)

2) Brake fluid should be changed at owner request every second year (once a year if the car is driven in mountainous areas or in areas with high humidity).

The following items should be checked weekly by the driver (it takes only a few minutes).

Engine oil level

Horns

Brake fluid level

Windshield wipers

Radiator coolant level

Tire pressure (all five tires)

Operation of all lights

Level of windshield washer fluid

The following should also be carried out at regular intervals:

Washing (check all drain holes)

Polishing

Cleaning



[Contents](#) | [Top of Page](#)

Hoisting the car

If a garage jack is used to lift the car, the two jack attachments points should be used. They are specially reinforced to bear the weight of the car. A garage jack can also be placed under the front of the engine support frame and under the reinforced plate in the spare wheel well. Take care not to damage the splash guard under the engine. **Ensure that the jack is positioned so that the car cannot slide off it. Always use axle stands or similar structures.**

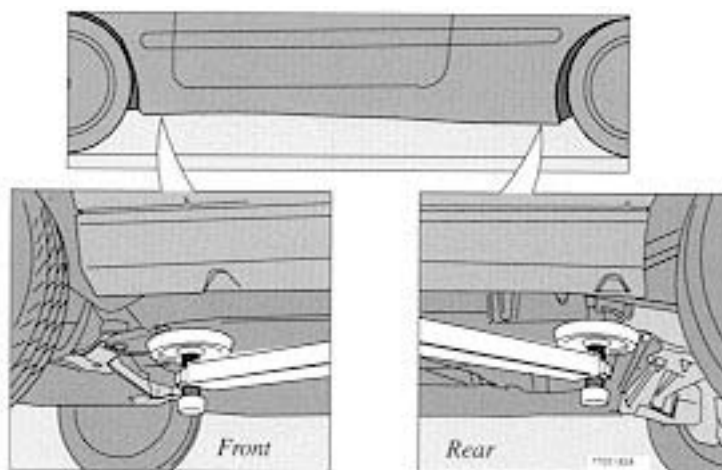

If a two-post hoist is used to lift the car, the front and rear lift arm pads should be centered under the reinforced lift plates on the inboard edge of the sill rail. The position of these plates is marked with arrows molded into the bottom of the sill rail.

CAUTION: Certain models have reduced ground clearance due to the design of the front spoiler. Please observe caution when driving the car onto a garage hoist.

Torque exhaust and intake manifold nuts

A loose manifold could alter air/fuel ratio and cause an increase in emission and/or poor driveability.

Air cleaner

Replace the air cleaner cartridge with a new one every 30,000 miles (48,000 km). The cartridge should be replaced more often when driving under dirty and dusty conditions. The filter cannot be cleaned and therefore should always be replaced with a new one.

Vacuum fittings, hoses and connections

Unstable idle, misfiring, or poor emission control is often caused by leaking vacuum hoses or

connections. Check all vacuum hoses and connections.

Idle air control system

Your Volvo is equipped with an electronically controlled idle air control system that requires no checking or adjustment.

Fuel system cap, tank and lines and connections

The effectiveness of the fuel system to contain hydrocarbons is dependent largely on a leak-free system. Check for proper sealing of the gasoline filler cap which contains "O" ring type seals.

Fuel (line) filter

The fuel line filter is located next to the fuel pump. For proper functioning of the vehicle and its emission control systems, the fuel line filter should be replaced at 100,000 miles (160,000 km). The filter is replaced as one complete unit. Replace more frequently if contaminated fuel is introduced into the tank (or if there is reason to suspect that this has occurred).

PCV system

The orifice nipple in the intake manifold and the filter at the end of the PCV hose in the air cleaner should be inspected every 60,000 miles (96,000 km). Check/replace rubber hoses at the same time.

Cabin air filter

Replace the cabin air filter with a new one every 20,000 miles (32,000 km). The filter should be replaced more often when driving under dirty and dusty conditions. The filter cannot be cleaned and therefore should always be replaced with a new one.

Timing belt

For proper functioning of the vehicle and its emission control systems, Volvo **recommends** that the timing belt be **replaced every** 70,000 miles (112,000 km). Engine damage will occur if the belt fails.

pg. 114 Fuel/emissions systems

Fuel System

The fuel system is all-electronic and is microprocessor-controlled. It can continually compensate for variation in engine load, speed and temperature to give the best economy and power. A mass air flow sensor measures the inducted air. In this way the system can make instantaneous adjustments for changes in air temperature or density, thus always assuring the best economy with the lowest possible exhaust emissions.

Heated oxygen sensor

This is an emission control system designed to reduce emissions and improve fuel economy. The heated oxygen sensor monitors the composition of the exhaust gases leaving the engine. The exhaust gas analysis is fed into an electronic module. This adjusts the air-fuel ratio to provide optimum conditions

for combustion and efficient reduction of the three major pollutants (hydrocarbons, carbon monoxide and oxides of nitrogen (NO_x) by a three-way catalytic converter.

Secondary Air Injection (certain models)

This system adds air to the hot exhaust gases as they are expelled from the engine. This causes a secondary combustion of residual hydrocarbons and carbon monoxide, resulting in lower emissions levels in the exhaust gases.

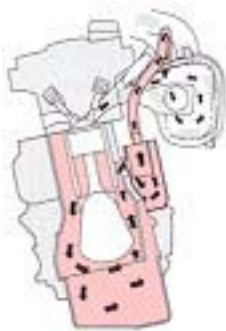

Crankcase ventilation

Crankcase ventilation

The engine is provided with positive crankcase ventilation which prevents crankcase gases from being released into the atmosphere. Instead, the crankcase gases are admitted to the intake manifold and cylinders.

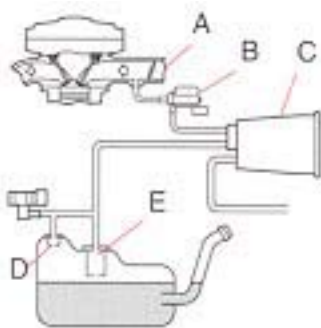

Evaporative control system

A -intake manifold, B -EVAP valve, C -charcoal canister, D -rollover valve, E -ORVR

Evaporative control system

The car is equipped with a gas evaporative control system which prevents gasoline vapor from being released into the atmosphere. The system is comprised of an expansion chamber in the fuel tank, a rollover valve, a charcoal canister, vapor vent lines, an EVAP valve and on certain models, an Onboard Refueling Vapor Recovery valve (ORVR). The gasoline vapor is channeled through the rollover valve and the ORVR (if applicable) via the vent lines into the charcoal canister, where it is stored. When the engine is started, the gasoline vapor is drawn from the charcoal canister to the engine's air intake system and into the combustion process.

NOTE:

- Overfilling the gas tank can cause damage to the evaporative control system.
- If the fuel filler cap is not closed tightly or if the engine is running when the car is refueled, the Malfunction Indicator Lamp may indicate a fault.
- During a transitional period, a small number of service stations may still have fuel nozzles that are not compatible with the fuel filler neck on cars equipped with the evaporative control system (ORVR) mandated by the U.S. Environmental Protection Agency and the California Air Resources Board. If you experience difficulties in refueling your vehicle, please ask the gas station attendant for assistance.

CAUTION: Fuel must not be siphoned from the fuel tank. This will damage the Evaporative control system.

pg. 115 Lubrication

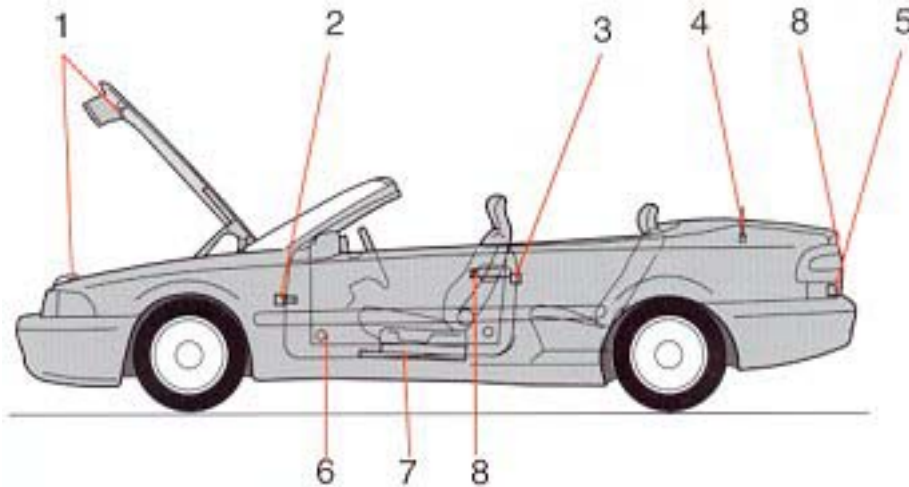

No.	Lubrication point	Lubricant
1	Hood lock and latch	Oil
2	Door stop and hinges	Oil
3	Door lock catch plate	Low temperature grease
4	Power antenna	WD 40 or similar
5	Trunk lock catch plate	Low temperature grease
6	Power window winders	Oil
7	Front seat side rail and latch	Oil

8 Locks

Volvo teflon lock spray

To avoid rattles and unnecessary wear, the body and convertible top mechanism should be lubricated at regular service intervals. This should be done by an authorized Volvo retailer.



[Contents](#) | [Top of Page](#)

Checking the oil level

The oil level should be checked every time the car is refuelled. This is especially important during the engine break-in period (up to the first service).

CAUTION : Not checking the oil level regularly can result in serious engine damage if the oil becomes too low.

Park the car on a level surface and wait for at least 3 minutes after the engine has been switched off. Be sure the oil level is maintained between the upper and lower marks on the dipstick. Low oil level can cause internal damage to the engine and over-filling can result in high oil consumption. The distance between the dipstick marks represents approx. 1.6 US qts (1.5 liters). The oil should preferably be checked when cold, before the engine has been started.

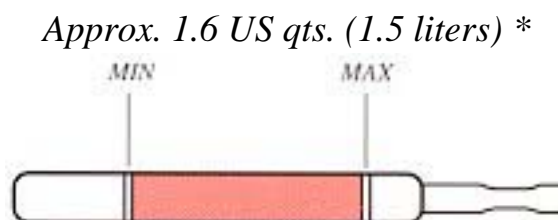

NOTE: The engine must be stopped when checking the oil.

Draining the oil

Drain the oil after driving while it is still warm.

WARNING! The oil may be very hot.

If you change the engine oil and filter yourself, your Volvo retailer can assist you in disposing of the used oil. Engine oil can be harmful to your skin - gloves should be worn when performing this work.

To add or change oil

Add oil of the same kind as already used.

Capacity (including filter): 6.1 US qts (5.8 liters).*

The oil filter should be replaced at every oil change

* Add 0.95 qts (0.9 liters) if the oil cooler has been drained.

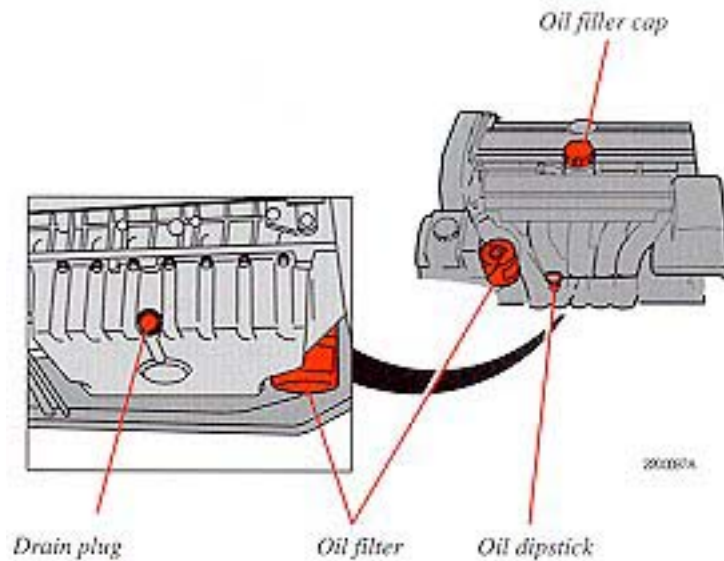

WARNING! Oil spilled on a hot exhaust pipe constitutes a fire risk.

pg. 117 Engine oil (cont.)

Oil quality

Meeting API specification SG, SG/CD, SH or Energy Conserving (EC) II



American Petroleum Institute (API) labels

For best fuel economy and engine protection consult with your authorized Volvo retailer for recommended oils. Oils with a different quality rating may not provide adequate engine protection.

Viscosity (stable ambient temperatures):

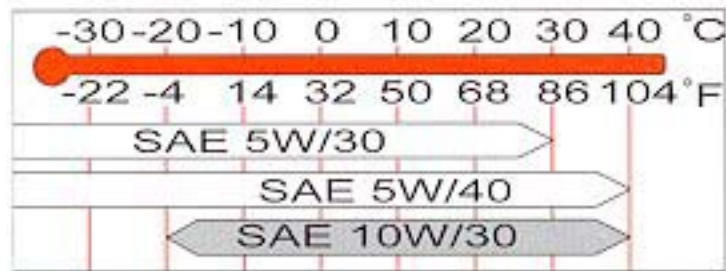

Do not use oils with other viscosity ratings. The use of incorrect viscosity oil can shorten engine life. Volvo recommends the use of energy-conserving oils. Look for the API label. Synthetic oils complying with oil quality requirements are recommended for: Driving in areas of sustained temperature extremes (hot or cold), when towing a trailer over long distances or for a prolonged driving in mountainous areas. **Extra oil additives must not be used unless advised by an authorized Volvo retailer.**

NOTE: SAE 15W-40 is should only be used in extreme operating conditions such as trailer towing in sustained ambient temperatures over 104° F (40° C). However, SAE 10W-30 synthetic oil would be a better alternative in such conditions.

SAE 15W-40 should not be used under normal operating conditions.

pg. 118 Power steering fluid, Brake/clutch fluid reservoir

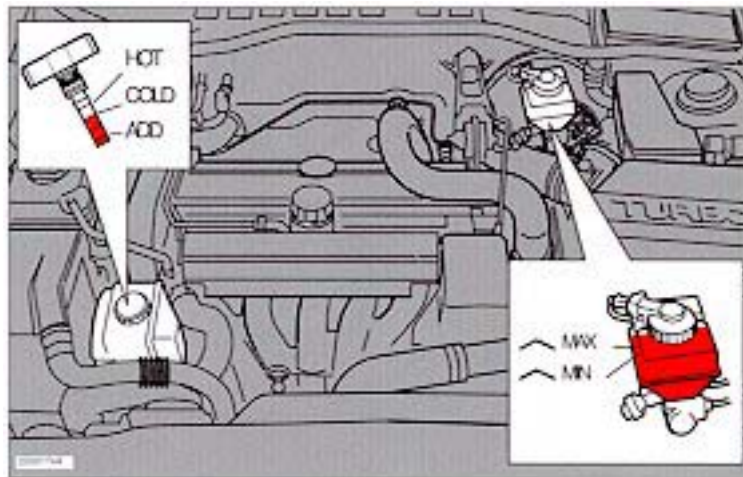

Power steering fluid

Brake (clutch) fluid

Power steering fluid

The dipstick has marks for checking hot and cold oil. The oil level when the engine is cold must never be higher than the **COLD** mark. After the engine has reached normal operating temperature, the level may not be higher than the **HOT** mark. Top up when the level is at the **ADD** mark.

Check the level at every service.

Fluid type: ATF

Replace: no fluid change required.

Brake and clutch systems

The brake and clutch systems share the same fluid reservoir. The fluid level should be between the MIN and MAX marks.

Fluid type: DOT 4+

Replace: Every second year or 30,000 miles (48,000 km). The fluid should be replaced once a year or every 15,000 miles (25,000 km) when driving under extremely hard conditions (mountain driving, etc.)

Check, without removing the cap, that the level is above the "MIN" mark of the fluid reservoir. Always entrust brake/clutch fluid changing to an authorized Volvo retailer.

pg. 119 Automatic transmission fluid

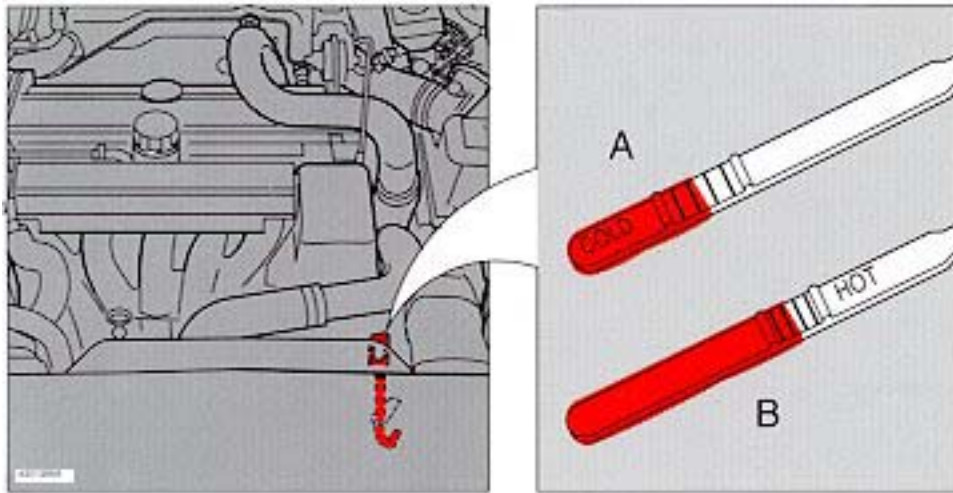

Check the oil level as follows:

Park the car on a level surface **with the engine idling**. Slowly move the gear selector lever through all the shift positions and then to position P. Wait 3 minutes before checking the oil level.

As the illustration shows, the dipstick has a **COLD** and a **HOT** side. The oil level should be between the MIN and MAX marks. Wipe the dipstick with a clean cloth.

WARNING! The oil may be very hot.

Do not use rags that could leave lint on the dipstick. The transmission is topped up via the dipstick tube. The space between the MIN and MAX marks on the dipstick corresponds to 0.5 US qt. (0.5 liter). Do not fill the transmission with too much oil, since this can result in oil being ejected from the transmission. Too little oil, on the other hand, can negatively affect transmission operation, particularly in very cold weather.

A Cold transmission: oil temperature 105° F (40° C). This is a normal temperature for the transmission after idling for about 10 minutes. At oil temperatures below 105° F (40° C), the level may be below the MIN mark.

B Warm transmission: oil temperature 169° F (80° C). This temperature after driving for about 30 minutes. At oil temperatures above 190° F (90° C), the level may be above the MAX mark.

Fluid type: ATF Dexron IIE/III and Mercon.

WARNING! Oil spilled on a hot exhaust pipe constitutes a fire risk.



[Contents](#) | [Top of Page](#)

pg. 120 Drive belt

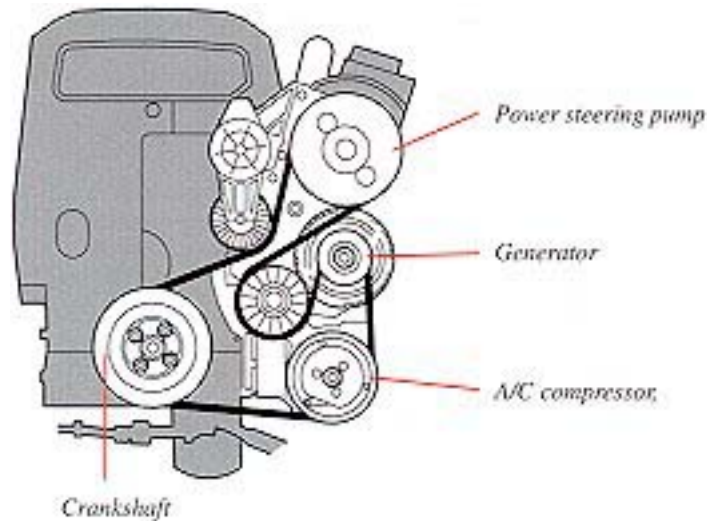
**Belt check**

Check the belt regularly to make sure it is in good condition and is clean. A worn or dirty belt can cause poor cooling and low generator output as well as impair the operation of the power steering and the air conditioning unit.

NOTE: The belt on the C 70 is equipped with a self-tensioning mechanism and requires no adjustment between changes.

WARNING! The engine must not be running when this check is performed.

pg. 121 Windshield washer nozzles, Washer fluid reservoir

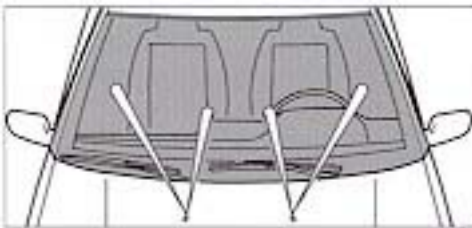
**Adjusting washer nozzles**

The washer jets should spray the windshield as shown in the illustration. Use the edge of a small screwdriver to adjust the nozzles if necessary.

Please use caution to avoid damaging the paintwork.

**Washer fluid reservoir**

The washer fluid reservoir is located in the engine compartment and holds approx. 4.7 US qts. (4.5 liters).

During cold weather, the reservoir should be filled with windshield washer solvent containing anti-freeze.

Check coolant level

The cooling system must be filled with coolant and not leak to operate at maximum efficiency. Check the coolant level regularly. The level should be between the "MAX" and "MIN" marks on the expansion tank. The check should be made with particular thoroughness when the engine is new or when the cooling system has been drained.

Do not remove the filler cap other than for topping up with coolant. Frequent removal may prevent coolant circulation between the engine and the expansion tank during engine warm up and cooling.

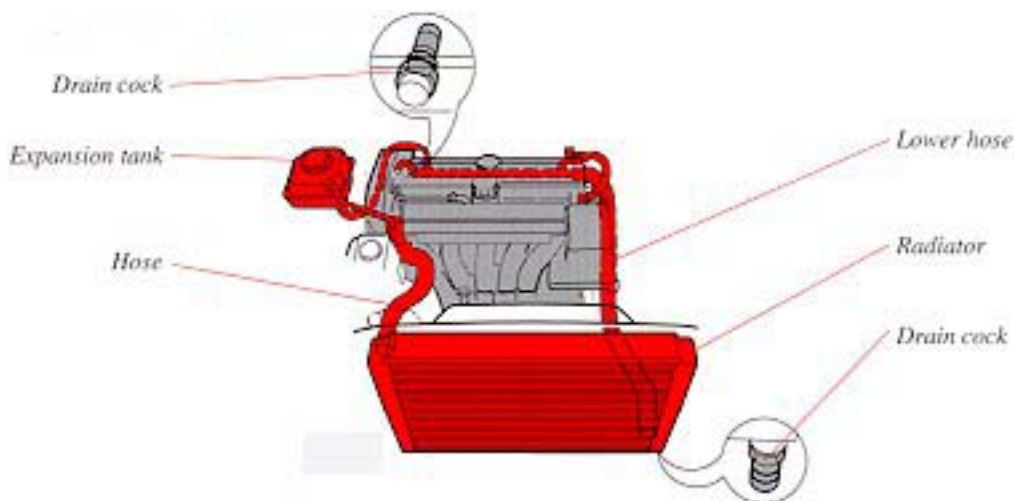

Changing coolant

Normally, the coolant does not need to be changed. If the system must be drained, use the following procedure:

Draining:

- 1 Remove the expansion tank cap.
- 2 Move the temperature adjustment control to max. heat. Open the drain cocks at the rear left of the engine block and at the bottom right corner of the radiator.
- 3 Disconnect the lower right radiator hose.

Filling:

- 4 Close the drain cocks and reconnect the hose.
- 5 Fill the expansion tank to the MAX mark or slightly above.
- 6 Run the engine until hot. Check the cooling system connections for tightness. Recheck the coolant level.

Capacity: 7.4 US qts. (7.0 liters)

Coolant: Volvo Genuine Coolant/Antifreeze only

NOTE: Do not top up with water only. Water by itself reduces the rust-protective and anti-freeze qualities of the coolant and has a lower boiling point. It can also cause damage to the cooling system if it should freeze.

WARNING: If the engine is warm and you are going to top up coolant, unscrew the cap slowly in order to allow any excess pressure to escape.

CAUTION: The cooling system must always be kept filled to correct level. If it is not kept filled, there can be high local temperatures in the engine which could result in damage. Different types of anti-freeze/coolant may not be mixed.

pg. 123 Engine compartment

Engine compartment - Volvo C 70 convertible

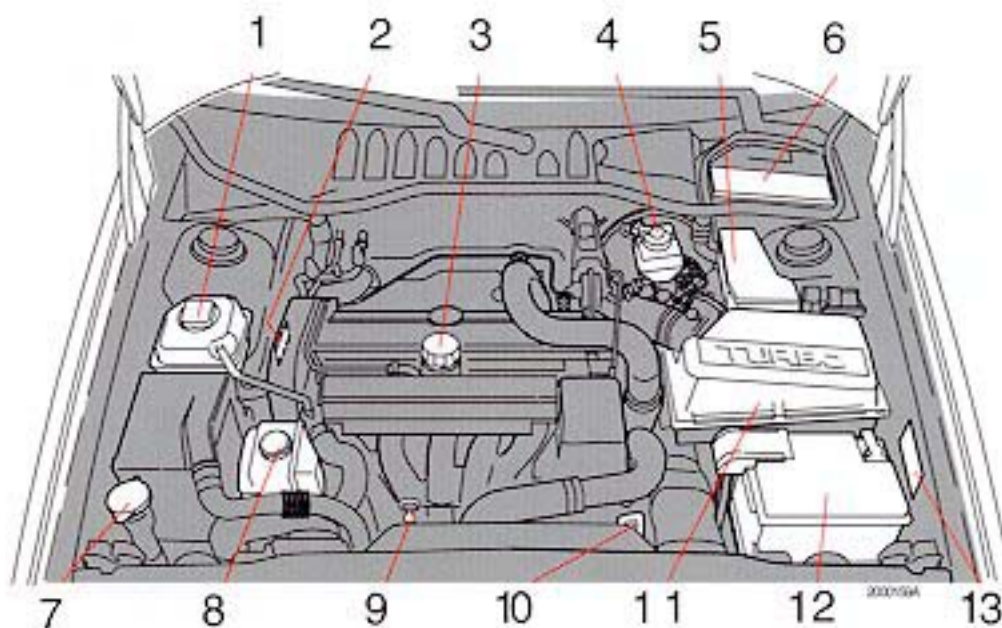

1. Expansion tank, coolant
2. Engine designation plate
3. Oil filler cap, engine
4. Clutch/brake system fluid reservoir
5. Relay/Main fuse box
6. Supplementary fuse box
7. Washer fluid reservoir
8. Power steering fluid reservoir
9. Dipstick - engine oil
10. Dipstick - automatic transmission
11. Air cleaner
12. Battery
13. Data plate

WARNING! The cooling fan may start or continue to operate (for up to 6 minutes) after the engine has been switched off.

pg. 124 Battery maintenance

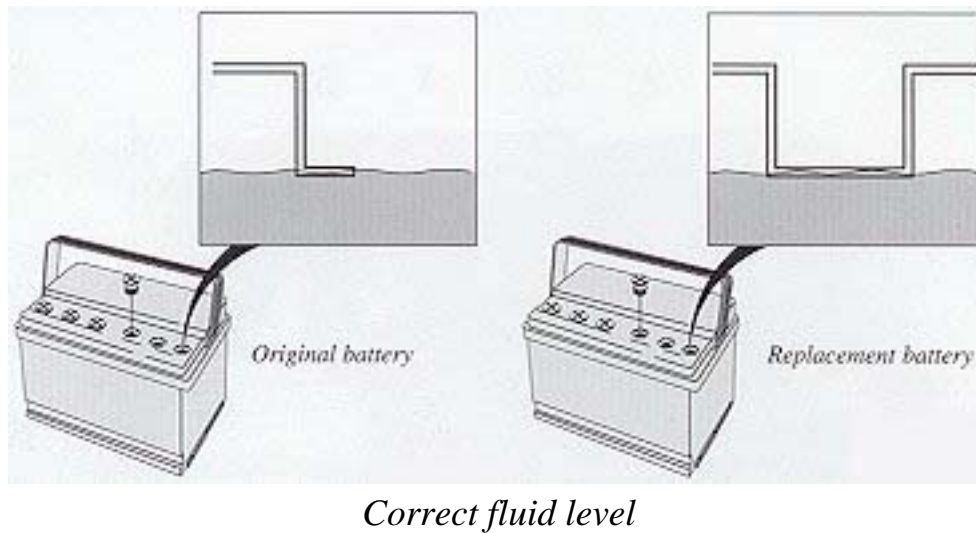

Battery maintenance

Driving habits and conditions, climate, the number of starts, etc. all affect the service life and function of the battery. In order for your battery to perform satisfactorily, keep the following in mind:

- Check the fluid level in the battery every 6 months or every 10,000* miles (16,000 km). The fluid level in each battery cell should be checked - use a screwdriver to open the caps and a flashlight to inspect the level.
* More frequently in warm climates.
- If necessary, add **distilled water** to approximately 0.4 in. (10 mm) above the plates in the cell or to the level indicator. See the illustration above.
- Check that the battery cables are correctly connected and properly tightened.
- Never disconnect the battery when the engine is running, for example when changing the battery.
- The battery should be disconnected when a boost charger is used.
- Switch off the radio before disconnecting the battery. If your radio has an antitheft code and the battery is disconnected, the radio code has to be reentered in order for the radio to function.

Battery warning symbols



Wear protection goggles



See inside for details



Keep away from children



Corrosive



No smoking, no open flames, no sparks



Explosion



[Contents](#) | [Top of Page](#)

Chapter 9 - Specifications

pg. 125 Specifications

Specifications

This chapter contains facts and figures pertaining to the technical specifications of your car.

<u>Oil/Fluids specifications</u>	<u>126</u>
<u>Engine specifications</u>	<u>127</u>
<u>SA ignition systems</u>	<u>128</u>
<u>Front/rear suspensions</u>	<u>128</u>
<u>Transmission, Capacities, Vehicle loading</u>	<u>129</u>
<u>Electrical system/bulbs</u>	<u>130</u>
<u>Dimensions and weights</u>	<u>131</u>
<u>Service manuals, Road assistance</u>	<u>132</u>

pg. 126 Oil/fluid specifications

Oil quality

Meeting API specification SG, SG/CD, SH or Energy Conserving (EC) II

For best fuel economy and engine protection, consult with your authorized Volvo retailer for recommended oils. Oil with a different quality rating may not provide adequate engine protection. Synthetic oils complying with oil quality requirements are recommended for : driving in areas of sustained temperature extremes (hot or cold), when towing a trailer over long distances or for prolonged driving in mountainous areas.

Extra oil additives must not be used unless advised by an authorized Volvo retailer.

NOTE: SAE 15 W-40 oil should only be used in extreme operating conditions such as trailer towing in sustained ambient temperatures over 104° F (40° C). However, SAE 10W-30 synthetic oil would be a better alternative in such conditions. **SAE 15W-30 should not be used under normal operating conditions.**

Viscosity (stable ambient temperatures):

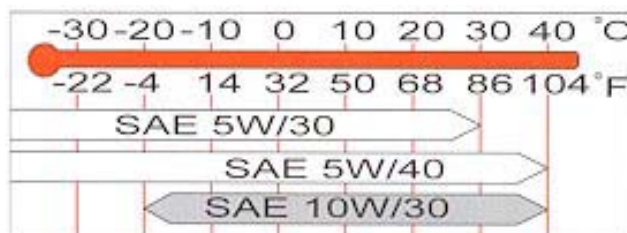

Engine oil	Quality: Meeting API specification SG or SH	Capacity (incl. filter): 6.1 US qts. (5.8 liters)*
Automatic transmission fluid	Quality: ATF Dexron IIE/ III and Mercon	Capacity: 8 US qts. (7.6 liters)
Manual transmission fluid	Quality: Volvo synthetic gearbox oil 1161423	Capacity: 2.2 US qts (2.1 liters)
Power steering fluid	Quality: ATF	Capacity: 0.85 US qts. (0.8 liters)
Brake fluid	Quality: DOT 4+	Capacity: 0.64 US qts. (0.6 liters)

* Add 0.95 qts. (0.9 liters) if the oil cooler has been drained

All specifications are subject to change without notice.

pg. 127 Engine

Engine

Liquid-cooled gasoline, 5-cylinder, in-line engine. Aluminum alloy cylinder block with cast-iron cylinder liners cast directly into block. Aluminum alloy cylinder head with double overhead camshafts and separate intake and outlet channels.

Engine lubrication is provided by an eccentric pump driven from the crankshaft. Full-flow type oil filter. Exhaust emission control accomplished by multiport fuel injection, heated oxygen sensor(s) and three-way catalytic converter.

Designation: Volvo B 5254 T

Output	190 hp at 5100 rpm (142 kw 85 rps)
Max torque	199 ft. lbs. at 1800-4998 rpm (270 Nm/30-83.3 rps)
Number of cylinders	5
Bore	3.27" (83 mm)
Stroke	3.54" (90 mm)
Displacement	2.4 liters
Compression ratio	9.0:1
Number of valves	20
Valve clearance	Self-adjusting

Designation: Volvo B 5234 T3

Output	236 hp at 5100 rpm (176 kw/85 rps)
Max torque	243 ft. lbs. at 2700-5100 rpm (330 Nm/45-85 rps)
Number of cylinders	5
Bore	3.19" (81 mm)
Stroke	3.54" (90 mm)
Displacement	2.3 liters
Compression ratio	8.5:1
Number of valves	20
Valve clearance	Self-adjusting

Charge air cooler (intercooler)

Turbocharged engines employ a turbo-compressor to force air into the engine inlet manifold and a charge air cooler to cool the compressed inlet air. The resulting increase in air flow raises pressure in the intake manifold by approx. 8.7 psi (over atmospheric pressure) and engine power output by approx. 50 horsepower over that developed by the normally-aspirated engine. The charge air cooler (which resembles a radiator) is located between the turbo-compressor and inlet manifold.

All specifications are subject to change without notice.



[Contents](#) | [Top of Page](#)

Cooling system

Type: Positive pressure, closed system
 Thermostat begins to open at 180°F (87°C)
 Coolant: Volvo original coolant/anti-freeze
 Capacity: 7.4 US qts. (7.0 liters)

Fuel system

The engine is equipped with a multiport fuel injection system

Distributor ignition system

Firing order: 1-2-4-5-3
 Distributor ignition setting: Not adjustable
 Spark plugs: Champion RC8PYP (or equivalent)
 Spark plug gap: 0.03" (0.75 mm)
 Tightening torque: 18.4 ft. lbs. +/- 3.7 ft. lbs. (25 Nm +/- 5 Nm)

WARNING! The distributor ignition system operates at very high voltages. Special safety precautions must be followed to prevent injury. Always turn the ignition off when:

- Replacing distributor ignition components e.g. plugs, coil, etc.
- Do not touch any part of the distributor ignition system while the engine is running. This may result in unintended movements and body injury.

Replacing spark plugs

The spark plugs should be changed every 30,000 miles (48,000 km). However, city driving or fast highway driving may necessitate changing after 15,000 miles (24,000 km) of driving. When installing new plugs, be sure to fit the right type and use correct torque, [see "Specifications"](#). When changing the plugs, check that the suppressor connectors are in good condition. Cracked or damaged connectors should be replaced. When changing the spark plugs, clean the terminals and the rubber seals.

Front suspension

Spring strut suspension with integrated shock absorbers and control arm linked to the support frame. Power-assisted rack and pinion steering. Safety type steering column.

The alignment specifications apply to an unladen car but include fuel, coolant, and spare wheel.

Toe-in measured on the wheel rims: 2.4 mm +/- 0.7 mm

Toe-in measured on tire sides: 2.9 +/- 0.9 mm

Rear Suspension

Delta-link individual rear-wheel suspension with longitudinal support arms, double link arms and track rods.

Toe-in measured on the tire sides: 4° +/- 10°

All specifications are subject to change without notice.

pg. 129 Specifications (cont.)

Power transmission

Manual transmission: M 56 H

Single-disc dry plate clutch. All-synchromesh on all gears including reverse; integrated final drive. Operation via a floor mounted gear lever.

Final drive ratio 4.00:1

Reduction ratios

1st gear	3.07:1
2nd gear	1.77:1
3rd gear	1.19:1
4th gear	0.87:1
5th gear	0.70:1
Reverse	2.99:1

Automatic transmission: AW 50-42 LE

4-speed automatic electronically controlled gearbox comprising a hydraulic torque converter with a lock-up function; planetary gear, integrated final drive.

Operation via a floor mounted gear selector lever. Drive shafts with symmetrical joint location.

Final drive ratio 2.54:1

Reduction ratios

1st gear	3.61:1
2nd gear	2.06:1
3rd gear	1.37:1
4th gear	0.98:1
Reverse	3.95:1

Capacities

Fuel tank	18.5 US gals (70 liters)
Cooling System	7.4 US qts. (7.0 liters)
Engine oil (incl. filter)	6.1 US qts. (5.8 liters)*
Automatic transmission	2 US gals (7.6 liters)
Manual transmission	2.2 US qts. (2.1 liters)
Power steering fluid	0.8 US qts. (0.8 liter)
Washer fluid reservoir	4.7 US qts. (4.5 liters)
Brake/clutch system	0.6 US qts (0.6 liters)

* Add 0.95 US qt. (0.9 liters) if the oil cooler has been drained.

Vehicle Loading

The tires on your Volvo should perform to specifications at all normal loads when inflated as recommended on the tire information label. The label is located on the inside of the fuel filler flap. The label lists both tire and vehicle design limits. Do not load your car beyond the load limits indicated.

WARNING! Improperly inflated tires will reduce tire life, adversely affect vehicle handling and can possibly lead to failure resulting in loss of vehicle control prior warning.

All specifications are subject to change without notice.

pg. 130 Specifications (cont.)

Electrical system

12 Volt, negative ground.

Voltage-controlled generator. Single-wire system with chassis and engine used as conductors.

Battery

Voltage	12 V
Capacity	600 A/100 min

The battery contains corrosive and poisonous acids. It is of the utmost importance that old batteries are disposed of correctly. Your Volvo retailer can assist you in this matter.

Generator

Rated output	1400 W
Max. current	100 A

Bulbs

Bulb	US No.	Power	Socket	No/ bulbs
Headlights				
High beam	H7	55W	–	2
Low beam	H7	55W	–	2
Front parking lights/turn signals	3357 NA	30/7 W/30/2.2 cp	W 2.5 x 15q	2
Turn signals, rear	–	21W	BAU 15	2
Tail lights	67	5 W/4cp	BA 15 s	4

Brake lights	1156	21W/32cp	BA 15 s	2
Back-up lights	1156	21W/32cp	BA 15 s	2
Rear fog light	1156	21W/32cp	BA 15 s	1
Front fog lights	H1	55 W	P 14.5s	2
License plate light	–	5 W	W 2.1x9.5d	2
Door open warning light	–	3 W	W 2.1x9.5d	4
Door step courtesy light	–	5W	W 2.1x9.5d	2
Trunk light	–	10 W	SV 8.5	1
Glove compartment light	–	2 W	BA 9s	1
Vanity mirror lights	–	1.2 W	–	2
Instrument lighting	–	3 W	W 2.1x9.5d	3
Illumination, control panel	–	1.2 W	W 2x4.6 d	–
gear selector (automatic trans.)	–	1.2 W	W 2x4.6 d	1
rear ashtray	–	1.2 W	W 2x4.6 d	1
Instrument warning/indicator lights	–	1.2 W	W 2x4.6 d	–
Front courtesy lights	–	5 W	BA 9s	2
Rear reading lights	–	5 W	BA 9s	2

All specifications are subject to change without notice

pg. 131 Specifications (cont.)

Dimensions - Volvo C 70 convertible

Length	185.8 in. (472 cm)
Width	71.7 in. (182 cm)
Height (convertible top raised)	56.3 in. (143 cm)
Wheelbase	104.7 in. (266 cm)
Track, front	59.8 in. (151.8 cm)
Track, rear	59.8 in. (151.8 cm)
Turning circle (between curbs)	38.4 ft. (11.7 m)
Cargo capacity	7.9 cu. ft. (0.22 m ³)

Weights - Volvo C 70 convertible

	USA	Canada
Gross vehicle weight (GVW)		
C 70 (auto)	4450 lbs (2018 kg)	2020 kg
C 70 (man.)	4410 lbs (2000 kg)	2000 kg
Capacity Weight *		
C 70 (B5234T3)	765 lbs (347 kg)	345 kg
C 70 (B5254T)	800 lbs (363 kg)	360 kg
Curb weight		
C 70	3630-3685 lbs (1647-1671 kg)	1645-1675 kg
Permissible axle weight, front		
C 70 (aut.)	2440 lbs (1170 kg)	1110 kg
C 70 (man.)	2380 lbs (1080 kg)	1080 kg
Permissible axle weight, rear		
C 70 (man./auto.)	2140 lbs (970 kg)	970 kg
Max trunk-mounted luggage rack load	110 lbs (50 kg)	50 kg
Max. trailer weight		
(w/o brakes)	1100 lbs (500 kg)	500 kg
(with brakes)		
2" ball	3300 lbs (1500 kg)	1500 kg
1 7/8" ball	2000 lbs (908 kg)	900 kg
Max. tongue weight **	165 lbs (75 kg)	75 kg

WARNING! When adding accessories, equipment, luggage and other cargo to your vehicle, the total loaded weight capacity of the vehicle must not be exceeded.

* The max permissible axle loads or the gross vehicle weight must not be exceeded.

** [See also section "Trailer towing"](#)

All specifications are subject to change without notice.

pg. 132 Service manuals, Road assistance

Service Manuals for your Volvo are available for purchase. These are the same manuals used by competent Volvo technicians.

Major sections within the Service Manual System include: 0- General Information; 1- Lubrication and Service; 2- Engine; 3- Electrical System; 4- Power Transmission; 5- Brakes; 6- Suspension and Steering; 7- Springs Shock Absorbers and Wheels; 8- Body and Interior.

To order service manuals or other technical information, call 1-800-25 VOLVO.



Volvo supports Voluntary Mechanic Certification by the A.S.E. Certified mechanics have demonstrated a high degree of competence in specific areas. Besides passing exams each mechanic must also have worked in the field for two or more years before a certificate is issued. These professional mechanics are fully able to analyze vehicle problems and perform the necessary service procedures to keep your Volvo at peak operating condition.

NOTE: The above pertains to the USA only.



Your new Volvo comes with a four year road assistance program named ON-CALL. Additional information, features, and benefits are described in a separate information package in your glove compartment.

All specifications are subject to change without notice.



[Contents](#) | [Top of Page](#)

Chapter 10 - Audio systems

pg. 133 Audio systems

Audio systems

This chapter describes the audio system in your car.

[SC-813](#) [134](#)

[SC-816](#) [147](#)

[SC-900](#) [163](#)

[General Information](#) [186](#)

pg. 134 Audio system SC-813 (certain models)

The following pages describe the use of your SC-813 Cassette radio and CD remote control



- | | | |
|-------------------------------------|--|--|
| 1. On/off (push) | 11. Dolby B NR button | 19. Cassette slot |
| 2. | 12. Cassette eject | 20. Display |
| 3. Volume (turn) | 13. Not in use | 21. Waveband selector (AM) |
| 4. Pause/Mute (push) | 14. Scan | 22. Waveband selectors (FM) |
| 5. Balance (pull) | 15. Auto seek memory | 23. Anti-theft LED |
| 6. Active Sound Control | 16. | |
| 7. CD changer selector | 17. Seek tuning up/down | |
| 8. | 18. TP -Next/Previous song | TP = Applicable only in Tape Mode |
| 9. Tape mode selector | 19. CD -Next UP/Previous DOWN track | |
| 10. Tape direction selector
PROG | 20. | CD = Applicable only when in CD mode and connected to a CD changer. |
| 11. Bass control | 21. Manual tuning | |
| 12. Treble control | 22. TP -fast forward/
Rewind | |
| 13. Fader control | 23. CD -Music search UP/
DOWN | |
| 14. | 24. RND button | |
| 15. Preset buttons | | |
| 16. CD-Disc No. selector | | |
| 17. PROG - Reversing the
tape | | |

pg. 135 Anti-theft code



Anti-theft code

The radio features anti-theft circuitry. If the set is removed from the vehicle or if the battery power is disconnected, a special code must be entered to enable operation of the set.

Refer to the radio code card supplied with your vehicle or ask your retailer for the correct code.

When the car is parked with the ignition key removed, the anti-theft LED will flash.



To enter the code

After installation or when the set has been disconnected from power, the set displays "COdE" when it is switched on.

Enter the 4-digit code using the preset buttons. If the correct code is entered, "on" is displayed and the set is ready to use.

If you enter an incorrect code you must enter the correct code again from the beginning.



Incorrect code

If an incorrect code has been entered "rPt" is displayed. Enter the correct code.

After three unsuccessful coding attempts the set will lock and remain locked for two hours. "**OFF**" is displayed.

During this waiting period:

- the battery must be connected
- the ignition key must be turned to position I
- the unit must be turned on

Make sure the headlights are turned off to help prevent battery drain (please refer to [page 24](#) for information on turning the headlights off). Enter the code again once this time has elapsed.



[Contents](#) | [Top of Page](#)

pg. 136 Radio SC-813

**A - On/off switch**

Push the button to switch on the radio. Press the button slightly longer to turn the radio off.

B - Volume control

Turn the button clockwise to increase the volume. The volume control is electronic and has no end stop.

C - Waveband selector

The desired waveband is set by pressing one of the waveband selector buttons. The frequency and waveband is shown on the display.

NOTE: There are two FM wavebands and one AM waveband. This makes it possible to store 2 x 6 FM stations and 6 AM stations in memory.

D - Setting frequency selection

The radio can be used in most parts of the world by changing the frequency selection intervals as follows:

Depress and hold preset button 5 and turn the radio ON. "USA" will flash on the display. Each time button 5 is pressed, the frequency selection will change from "USA" to "AUS", etc. When the correct country name is displayed, wait 5 seconds and the radio will be ready for use.

E - Manual tuning

Press the left side tune button to tune to lower frequencies and the right side to tune to higher frequencies. The tuned frequency is displayed.

ST will be displayed to indicate stereo FM reception.

pg. 137 Radio SC-813

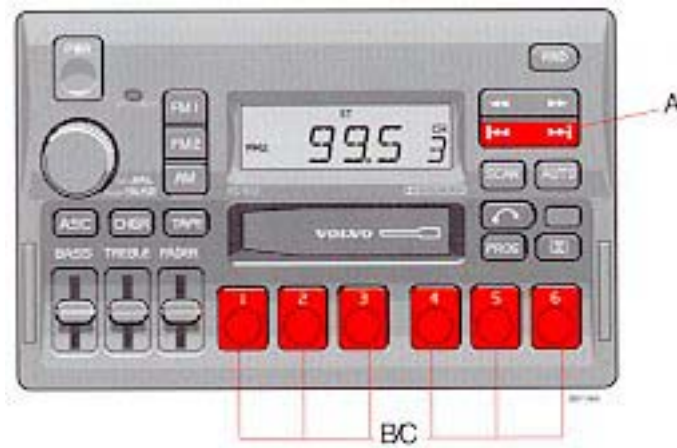

A - Seek tuning up/down

Press the left side tune button to tune to lower frequencies and the right side to tune to higher frequencies. The radio seeks the next audible station and stops there. If you wish to continue the seek tuning, press the tune button again.

B - Preset programming

1. Tune to the desired frequency.
2. Depress and hold a preset button. The audio will cut out. Keep the button depressed until the audio comes on again (approx. 2 seconds).
3. The frequency is now stored on this preset button.

C - Preset buttons

To select a pre-programmed radio frequency, depress the preset button. The set frequency will be displayed.

pg. 138 Radio SC-813



A- Automatic programming (Auto)

Please note that this function will not interfere with pre-stored stations on buttons 1-6.

This function automatically seeks and stores up to 8 strong AM or FM stations. This is especially useful when travelling in areas where radio stations are unfamiliar.

1. Depress and hold the "AUTO" button for **at least 1 second**. A number of strong stations (max. 8) on the chosen waveband are now automatically stored in the memory. If there are no audible stations, "- - -" is displayed.
2. Press the "AUTO" button (**for less than 1 second**) to obtain another autostored station. A new station will be selected each time the button is pressed momentarily.

B - Bass control

Adjust the bass by sliding the control up or down (up to increase, down to decrease) A "detent" indicates "equalized" bass.

C - Treble control

Adjust the treble by sliding the control up or down (up to increase, down to decrease). A "detent" indicates "equalized" treble.

pg. 139 Radio SC-813



A- Fader control

Adjust front/rear speaker balance by sliding the control up or down. (**UP** to direct more sound to the front speakers, **DOWN** to direct more sound to the rear speakers). The "detent" indicates "equalized" front /rear balance position.

B - Pause function

Press the "volume" knob to temporarily mute

C - Balance control

Pull out the "volume" knob and adjust the left/ right balance by turning the knob counterclockwise or clockwise.

D - Scan

Press this button to listen to each station for five seconds. Press it again to stop scanning. "Scan" will be displayed during scanning.

E - Active sound control (ASC)

The ASC function automatically adjusts the volume level of the audio system according to driving speed. To deactivate ASC depress the "ASC" button. To activate ASC, depress the "ASC" button until "ASC" is displayed.



[Contents](#) | [Top of Page](#)

pg. 140 Cassette deck

**A - Cassette slot**

The cassette is inserted with the open side to the right (side 1 or A of the cassette upwards). When the cassette is inserted, the radio is disengaged and the cassette will start to play automatically. "TAPE▶" or "TAPE◀" is displayed to indicate which side of the tape is being played. When one side of the tape has been played the unit will automatically play the other side (auto-reverse). The cassette can be inserted or ejected even when the unit is switched off.

B - Reversing the tape (PROG)

Press the button to play the other side of the tape.
The side of the tape being played will be displayed.

C - Fast winding

The tape is advanced with "▶▶" and rewind with "◀◀". Fast winding can be stopped by pressing either the selected button or the fast wind button again or by pressing the "TAPE" button.

D - Dolby B NR button

Press this button when you use tapes recorded with the Dolby B noise reduction system. The Dolby symbol  will be indicated in the display.

pg. 141 Cassette deck



A - Next selector

Press the "▶▶" button and the tape will automatically advance to the next song. There must be a gap (no audio sound) of approx. 5 seconds between songs for this function to operate.

B - Previous selector

Press the "◀◀" button and the tape will automatically rewind to the previous song. There must be a gap (no audio sound) of approx. 5 seconds between songs for this function to operate.

C - Pause

If you press the "volume" knob the tape is stopped, the unit is silent and "PAUSE" is displayed. To restart the tape press the knob again.

D - Scan

Press this button to listen to the first five seconds of each song. Press this button or the "TAPE" button to stop scanning. During scanning "SCAN" will be displayed. There must be a gap (no audio sound) of approx. 5 seconds between songs for this function to operate.

pg. 142 Cassette deck



A - Cassette eject

If the button is pressed the tape will stop and the cassette will be ejected. The radio will be automatically engaged. The radio or CD changer will engage automatically (depending on which mode was activated before the tape was played).

B - To re-enter Radio mode

Push one of the waveband selector buttons. When the unit re-enters Radio mode, the cassette will not be ejected.

C - To re-enter Tape mode

If the Tape function has been disconnected and the cassette has not been ejected, the Tape mode can be re-entered by pressing the "TAPE" button.

D - To re-enter CD changer mode

If the CD changer function has been disconnected, the CD changer mode can be reentered by pressing the "CHGR" button.



[Contents](#) | [Top of Page](#)

pg. 143 CD - Changer (retailer option)

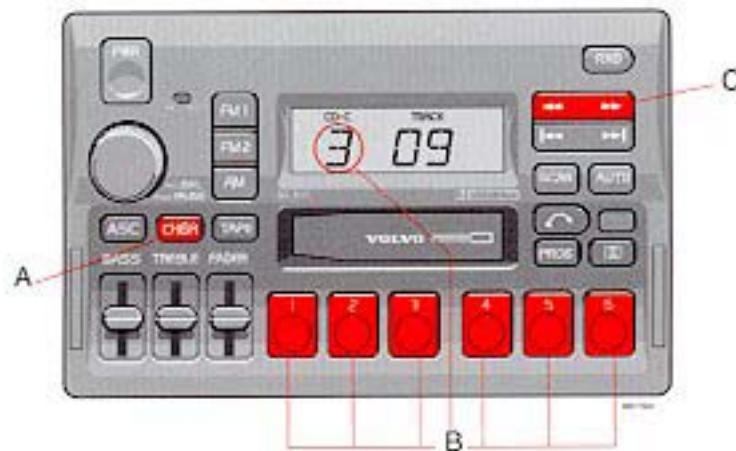
**A- CD changer mode selector**

Press "CHGR" to actuate the CD changer mode. The disc/track last listened to will continue to play. If the CD-changer cartridge* is empty, "---" will be displayed. If a selected disc does not exist, the disc number and "5--" will be displayed and the next disc will be automatically selected.

B - Disc number selector

Depress one of the preset buttons (1-6) to select the disc number desired. The selected disc number and track number will be displayed.

C - Music search

Press the "◀◀" or "▶▶" button to search within a track. While the button is depressed the playing time for this track will be displayed.

*The functions pertaining to the CD-changer are only applicable if the unit has been connected to the Volvo CD-changer, which is sold separately as an accessory.

If no CD-changer is connected to the unit "EEEE" will be displayed if you happen to choose CHGR mode.

pg. 144 CD - Changer (retailer option)



A - Changing the selected track number

Press "◀▶" for forward selection or "▶▶" for backward selection. The chosen disc number and track number will be displayed.

B - Playing-time display

When the "CHGR" button is pressed the playing time for the current track is displayed for 5 seconds.

C - Scan

Press this button to listen to the first ten seconds of each track. Press it again to stop scanning. During scanning "SCAN" will be displayed.

pg. 145 CD - Changer (retailer option)



A- Random choice

Press "RND" to actuate the random mode. From a disc chosen at random, 4 tracks will be played (also chosen at random)*. A new disc will then be played in the same way. "RND" will be displayed when this function is engaged.

* The random function may cause a disc to be played more than once before playing through all discs.

B - Pause

If you press the "volume" knob the disc is stopped, the unit is silent and "PAUSE" is displayed. To restart the disc press the knob again.

C - To re-enter Radio mode

Push one of the waveband selector buttons.

D - To re-enter Tape mode

If a cassette is already inserted, the tape deck will reengage if the "TAPE" button is pressed.

E - To re-enter CD changer mode

If the CD changer function has been disconnected, the CD changer mode can be reentered by pressing the "CHGR" button.

pg. 146 Technical specifications

SC-813

Power output:	4 x 25 W (10% dist.)
Output impedance:	4 Ohms
System voltage:	12 Volts, negative ground

Radio

System: PLL (Phase Lock Loop) system with tuned RF (Radio Frequency) front and end automatic wide band gain control. Electronic suppression circuitry (noise killer).

This Radio is equipped with FM-Diversity.

Frequency range:

AM	530 - 1710 kHz
FM	87.9 - 107.9 MHz

Sensitivity:

AM	20 μ V
FM	1.1 μ V
Stereo separation:	35 dB

Cassette deck

4-track, 2 channel stereo
Full logic electronic tape transport

Tape speed:	4.76 cm/sec.
Channel separation	53 dB
Frequency range	30-15000 hz
S/N (120 μ V)	56 dB without Dolby B NR
S/N (120 μ V)	66 dB with Dolby B NR
Wow and Flutter	< 0.06%
Pinch off	

"Dolby" and the double D symbol  are the trademarks of Dolby Laboratories Licensing Corporation. Dolby noise reduction manufactured under license from Dolby Laboratories Licensing Corporation.



[Contents](#) | [Top of Page](#)

pg. 147 Audio system SC-816 (certain models)

The following pages describe the use of your SC-816



- | | | |
|---|--|--|
| 1. On/off (push) | 10. Dolby B NR button | 19. CD slot |
| 2. | 11. CD-random play | 20. Cassette slot |
| 3. Volume (turn) | 12. Cassette eject | 21. Display |
| 4. Pause/Mute (push) | 13. Remote control window | 22. Waveband selector (AM) |
| 5. Balance (pull) | 14. Auto seek memory | 23. Waveband selectors (FM) |
| 6. Single CD mode selector - Active Sound Control | 15. Scan | 24. |
| 7. CD changer selector | 16. | 25. Anti-theft LED |
| 8. | 17. Seek tuning up/down | 26. Disc in LED (single) |
| 9. Tape mode selector | 18. TP -Next/Previous song | |
| 10. Tape direction selector PROG | 19. CD -Next UP/Previous DOWN track | TP = Applicable only in Tape Mode |
| 11. Bass control | 20. | CD = Applicable only when in CD mode and connected to a CD changer. |
| 12. Treble control | 21. Manual tuning | |
| 13. Fader control | 22. TP -Fast forward/Rewind | |
| 14. | 23. CD -Music search UP/DOWN | |
| 15. Preset buttons | 24. CD eject (single) | |
| 16. CD-Disc No. selector | | |

pg. 148 Anti-theft code



Anti-theft code

The radio features anti-theft circuitry. If the set is removed from the vehicle or if the battery power is disconnected, a special code must be entered to enable operation of the set.

Refer to the radio code card supplied with your vehicle or ask your retailer for the correct code.

When the car is parked with ignition key removed the anti-theft LED will flash.



To enter the code

After installation or when the set has been disconnected from power, the set displays "CODE" when it is switched on.

Enter the 4-digit code using the preset buttons. If the correct code is entered the set is ready to use.

If you enter an incorrect code you must enter the correct code again from the beginning.



Incorrect code

If an incorrect code has been entered "EEEE" is displayed. Enter the correct code. After three unsuccessful coding attempts the set will lock and remain locked for two hours. "OFF" is displayed.

During this waiting period:

- the battery must be connected
- the ignition key must be turned to position I

- the unit must be turned on

Make sure the headlights are turned off to help prevent battery drain (please refer to [page 24](#) for information on turning the headlights off). Enter the code again once this time has elapsed.

pg. 149 Radio SC-816



A- On/off switch

Push the button to switch on the radio. Press the button to turn the radio off.

B - Volume control

Turn the button clockwise to increase the volume. The volume control is electronic and has no end stop.

C - Waveband selector

The desired waveband is set by pressing one of the waveband selector buttons. The frequency and waveband is shown on the display.

NOTE: There are two FM wavebands and one AM waveband. This makes it possible to store 2 x 6 FM stations and 6 AM stations in the memory.

D - Setting frequency selection

The radio can be used in most parts of the world by changing the frequency selection intervals as follows:

Depress and hold preset button 5 and turn the radio ON. "USA" will flash on the display. Each time button 5 is pressed, the frequency selection will change from "USA" to "AUS", etc. When the correct country name is displayed, wait 5 seconds and the radio will be ready for use.

E - Manual tuning

Press the left side tune button to tune to lower frequencies and the right side to tune to higher frequencies. The tuned frequency is displayed.

ST will be displayed to indicate stereo FM reception.

pg. 150 Radio SC-816

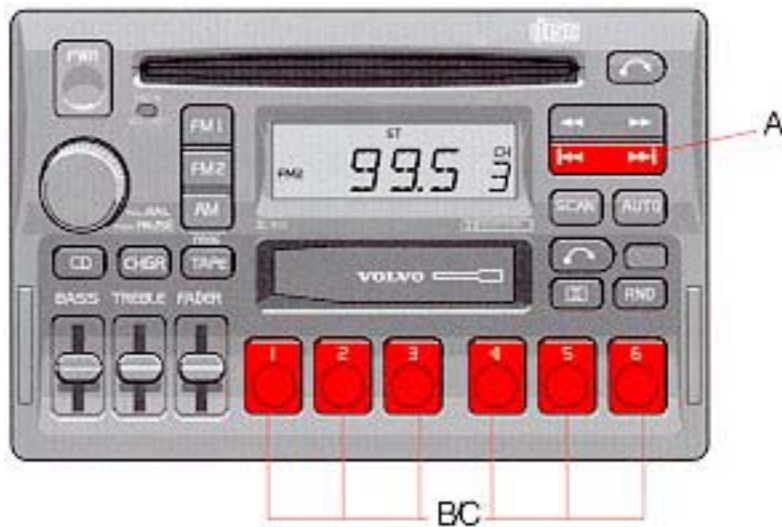

A - Seek tuning up/down

Press the left side tune button to tune to lower frequencies and the right side to tune to higher frequencies. The radio seeks the next audible station and stops there. If you wish to continue the seek tuning, press the tune button again.

B - Preset programming

1. Tune to the desired frequency.
2. Depress and hold a preset button. The audio will cut out. Keep the button depressed until the audio comes on again (approx. 2 seconds).
3. The frequency is now stored on this preset button.

C - Preset buttons

To select a pre-programmed radio frequency, depress the preset button. The set frequency will be displayed.

pg. 151 Radio SC-816



A- Automatic programming (Auto)

Please note that this function will not interfere with pre-stored stations on buttons 1-6.

This function automatically seeks and stores up to 8 strong AM or FM stations.

This is especially useful when travelling in areas where radio stations are unfamiliar.

1. Depress and hold the "AUTO" button for **at least 1 second**. A number of strong stations (max 8) on the chosen waveband are now automatically stored in the memory.
The lowest frequency station is heard. If there are no audible stations, "- - - -" is displayed.
2. Press the "AUTO" button (**for less than 1 second**) to obtain another autostored station.
A new station will be selected each time the button is pressed momentarily.

B - Bass control

Adjust the bass by sliding the control up or down (up to increase, down to decrease). A "detent" indicates "equalized" bass.

C - Treble control

Adjust the treble by sliding the control up or down (up to increase, down to decrease). A "detent" indicates "equalized" treble.



A- Fader control

Adjust front/rear speaker balance by sliding the control up or down. (**UP** to direct more sound to the front speakers **DOWN** to direct more sound to the rear speakers).

The "detent" indicates "equalized" front /rear balance position.

B - Pause function

Press the "volume" knob to temporarily mute the sound. "PAUSE" is displayed.

C - Balance control

Pull out the "volume" knob and adjust the left/ right balance by turning the knob counterclockwise or clockwise.

D - Scan

Press this button to listen to each station for five seconds. Press it again to stop scanning.

E - Active sound control (ASC)

The ASC function automatically adjusts the volume level of the audio system according to driving speed.

To deactivate ASC depress the "CD" button until "ASC" is no longer displayed. To activate ASC, depress the "CD" button until "ASC" is displayed (approx. 2 seconds).



[Contents](#) | [Top of Page](#)

pg. 153 Cassette deck

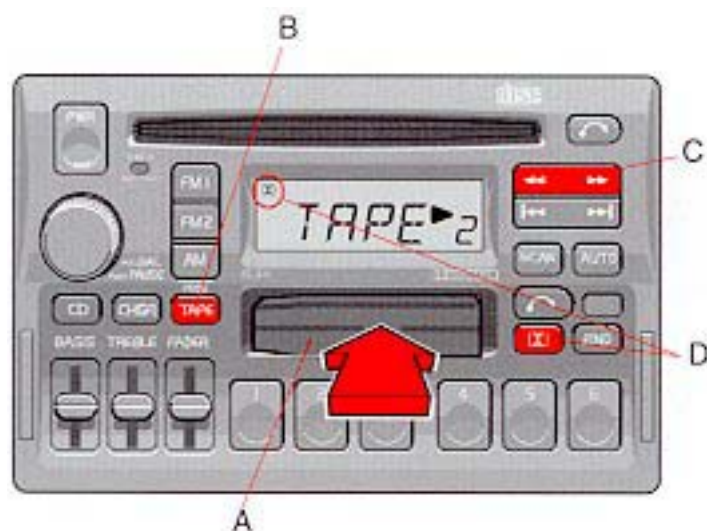
**A - Cassette slot**

The cassette is inserted with the open side to the right (side 1 or A of the cassette upwards). When the cassette is inserted, the radio is disengaged and the cassette will start to play automatically. "TAPE ▶" or "TAPE ◀" is displayed to indicate which side of the tape is being played. When one side of the tape has been played the unit will automatically play the other side (auto-reverse). The cassette can be inserted or ejected even when the unit is switched off.

B - Reversing the tape (PROG)

Press the button to play the other side of the tape.

C - Fast winding

The tape is advanced with "▶▶" and rewind with "◀◀". "FF" will be displayed while advancing the tape. "REW" will be displayed while rewinding the tape.

Fast winding can be stopped by pressing the tuning button or the TAPE button again.

D- Dolby B NR button

Press this button when you use tapes recorded with the Dolby B noise reduction system.

The Dolby symbol  will be indicated in the display.

pg. 154 Cassette deck



A - Next selector

Press the "▶▶" button and the tape will automatically advance to the next song. There must be a gap (no audio sound) of approx. 5 seconds between songs for this function to operate.

B - Previous selector

Press the "◀◀" button and the tape will automatically rewind to the previous song. There must be a gap (no audio sound) of approx. 5 seconds between songs for this function to operate.

C - Pause

If you press the "volume" knob the tape is stopped, the unit is silent and "PAUSE" is displayed. To restart the tape press the knob again.

D - Scan

Press this button to listen to the first five seconds of each song. Press it again to stop scanning. "SCAN" will be displayed. There must be a gap (no audio sound) of approx. 5 seconds between songs for this function to operate.

pg. 155 Cassette deck



A - Cassette eject

If the button is pressed the tape will stop and the cassette will be ejected. The radio will be automatically engaged. The radio, CD or CD changer will engage automatically (depending on which mode was activated before the tape was played).

B - To re-enter Radio mode

Push one of the waveband selector buttons. When the unit re-enters Radio mode, the cassette will not be ejected.

C - To re-enter CD changer mode

If the CD changer function has been disconnected, the CD changer mode can be reentered by pressing the "CHGR" button.

D - To re-enter CD mode

If the CD function has been disconnected and the CD has not been ejected, the CD mode can be re-entered by pressing the "CD" button.

E - To re-enter Tape mode

If the Tape function has been disconnected and the cassette has not been ejected, the Tape mode can be re-entered by pressing the "TAPE" button.



[Contents](#) | [Top of Page](#)

pg. 156 CD - Single

**A - CD slot**

With the audio system on, insert a disc into the slot with the label side up. When the CD is inserted, the radio is disengaged and the CD will start to play automatically.

The CD can be inserted or ejected even when the unit is switched off.

When the CD has been inserted into the player, the "DISC IN" light will always be ON even if the radio, tape deck or CD changer are in use.

B - CD mode selector

Press "CD" to actuate the CD mode. The track last listened to will continue to play. If the CD player is empty, "NO CD" will be displayed.

C - CD eject

If the button is pressed the CD will stop and the disc will be ejected. The radio will be automatically engaged. The radio, tape or CD changer will engage automatically (depending on which mode was activated before the CD was played).

NOTE: If the CD eject button is pressed and the disc is not removed within 12 seconds, the disc will be drawn into the CD player again.

pg. 157 CD - Single



A- Music search

Press the "◀◀" or "▶▶" button to search within a track. While the button is depressed the playing time for this track will be displayed.

B - Changing the selected track number

Press "▶▶|" for forward selection or "|◀◀" for backward selection. The disc number and the chosen track number will be displayed.

C - Playing-time display

When the "CD" button is pressed the playing time for the current track is displayed for 5 seconds.

D - Scan

Press this button to listen to the first ten seconds of each track. Press it again to stop scanning.

pg. 158 CD - Single



A- Random choice

Press "RND" to actuate the random mode. From a disc, tracks will be played at random*. "RND" will be

displayed when this function is engaged.

* The random function may cause a disc to be played more than once before playing through all discs.

B - Pause

If you press the "volume" knob the disc is stopped, the unit is silent and "PAUSE" is displayed. To restart the disc press the knob again.

C - To re-enter Radio mode

Push one of the waveband selector buttons

D - To re-enter Tape mode

If a cassette is already inserted, the tape deck will reengage if the "TAPE" button is pressed.

E - To re-enter CD mode

If the CD function has been disconnected and the CD has not been ejected, the CD mode can be re-entered by pressing the "CD" button.

F - To re-enter CD changer mode

If the CD changer function has been disconnected, the CD changer mode can be reentered by pressing the "CHGR" button.



[Contents](#) | [Top of Page](#)

pg. 159 CD - Changer (retailer option)

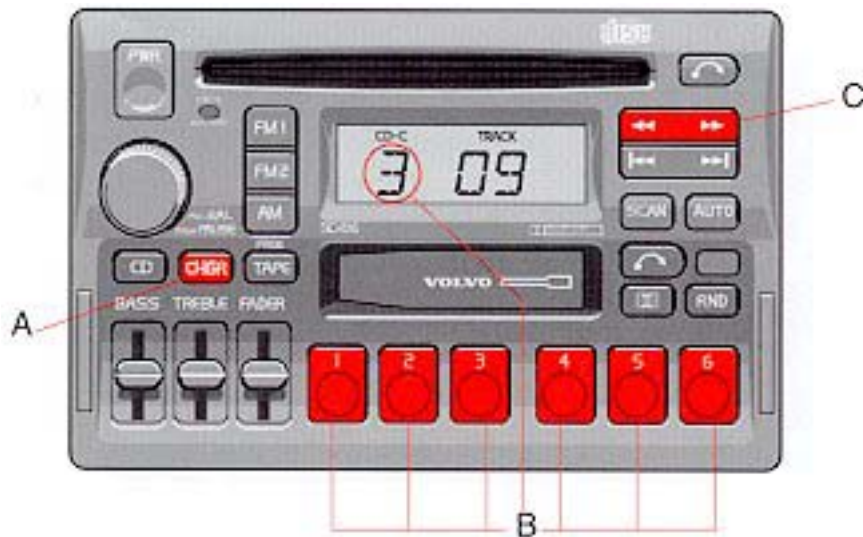
**A - CD changer mode selector**

Press "CHGR" to actuate the CD changer mode. The disc/track last listened to will continue to play. If the CD-changer cartridge* is empty, "0-00" will be displayed. If there is no cartridge in the changer "- - -" will be displayed. If a selected disc does not exist, the disc number and "-00" will be displayed and the next disc will be automatically selected.

B - Disc number selector

Depress one of the preset buttons (1-6) to select the disc number desired. The selected disc number and track number will be displayed.

C - Music search

Press the "◀◀" or "▶▶" button to search within a track. While the button is depressed the playing time for this track will be displayed.

*The functions pertaining to the CD-changer are only applicable if the unit has been connected to the Volvo CD-changer, which is sold separately as an accessory.

If no CD-changer is connected to the unit "EEEE" will be displayed if you happen to choose CHGR mode.

pg. 160 CD - Changer (retailer option)



A - Changing the selected track number

Press "▶▶|" for forward selection or "◀◀" for backward selection. The chosen disc number and track number will be displayed.

B - Playing-time display

When the "CHGR" button is pressed the playing time for the current track is displayed for 5 seconds.

C - Scan

Press this button to listen to the first ten seconds of each track. Press it again to stop scanning.

pg. 161 CD - Changer (retailer option)



A- Random choice

Press "RND" to actuate the random mode. From a disc chosen at random, 4 tracks will be played (also chosen at random). A new disc will then be played in the same way. "RND" will be displayed when this function is engaged.

B- Pause

If you press the "volume" knob the disc is stopped, the unit is silent and "PAUSE" is displayed. To restart the disc press the knob again.

C - To re-enter Radio mode

Push one of the waveband selector buttons.

D - To re-enter Tape mode

If a cassette is already inserted, the tape deck will reengage if the "TAPE" button is pressed.

E - To re-enter CD mode

If the CD function has been disconnected and the CD has not been ejected, the CD mode can be re-entered by pressing the "CD" button.

F - To re-enter CD changer mode

If the CD changer function has been disconnected, the CD changer mode can be reentered by pressing the "CHGR" button.

pg. 162 Technical specifications

SC-816

Power output: 4 x 60 W (10% dist.)
 Output impedance: 4 Ohms
 System voltage: 12 Volts, negative ground

Radio

System: PLL (Phase Lock Loop) system with tuned RF (Radio Frequency) front and end automatic wide band gain control. Electronic suppression circuitry (noise killer). The Radio is equipped with FM diversity.

Frequency range:

AM 530 - 1710 kHz
 FM 87.9 - 107.9 MHz

Sensitivity:

AM 20 μ V
 FM 1.1 μ V
 Stereo separation: 35 dB

Cassette deck

4-track, 2 channel stereo
Full logic electronic tape transport

Tape speed:	4.76 cm/sec.
Channel separation	53 dB
Frequency range	30-15000 hz
S/N (120 µV)	56 dB without Dolby B NR
S/N (120 µV)	66 dB with Dolby B NR
Wow and Flutter	< 0.06%
Pinch off	

"Dolby" and the double D symbol  are the trademarks of Dolby Laboratories Licensing Corporation. Dolby noise reduction manufactured under license from Dolby Laboratories Licensing Corporation.



[Contents](#) | [Top of Page](#)

pg. 163 Audio system SC-900 (certain models)

The following pages describe the function and operation of your SC-900.

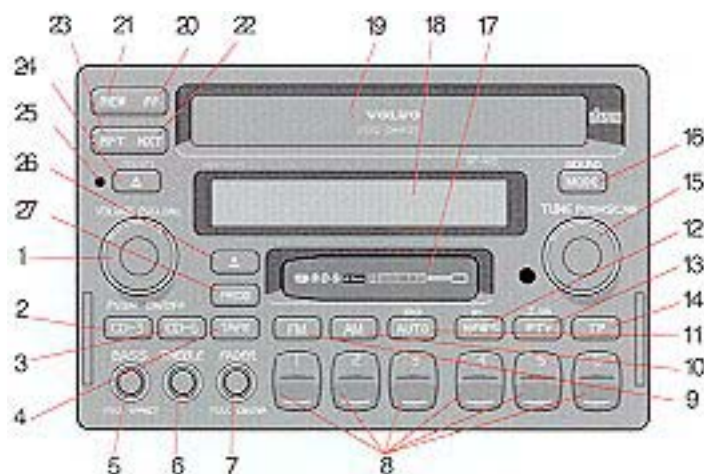

- | | | |
|---|----------------------------------|--------------------------------------|
| 1. On/off (press) | 11. | 21. Fast rewind |
| 2. Volume (turn) | 12. Autostore memory | 22. CD - backwards search |
| 3. Balance (pull out and turn) | 13. CD - random play | 23. Tape - backwards search |
| 4. CD player - on/off | 14. | 24. Radio - frequency down |
| 5. CD mode selector - on/off | 15. News | 25. |
| 6. Cassette deck - on/off | 16. Radio text | 26. CD - next track |
| 7. | 17. | 27. Tape - next track |
| 8. Bass control | 18. Program type selector | 28. Radio - next station (seek up) |
| 9. Volume control - sound effects (pull and turn) | 19. Dolby B noise reduction | 29. |
| 10. Treble control | 20. Traffic information selector | 30. CD - repeat previous track |
| 11. | 21. | 31. Tape - repeat previous track |
| 12. Balance control front/rear (fader) | 22. Manual tuning knob | 32. Radio - next station (seek down) |
| 13. Volume control - center speaker (pull and turn) | 23. Track selector - CD | 33. |
| 14. Preset buttons | 24. Scanning | 34. CD - open |
| 15. CD 3 disc selector 1-3 | 25. Pro Logic Surround Sound | 35. |
| 16. CD 6 disc selector 1-6 | 26. Cassette slot | 36. Anti-Theft indicator |
| 17. Waveband selector (FM) | 27. Display | 37. CD - warning indicator |
| 18. Waveband selector | 28. CD slot | 38. Cassette eject |
| | 29. Fast forward | 39. PROG - reversing the tape |
| | 30. CD - forward search | |
| | 31. Tape - forward search | |
| | 32. Radio - frequency up | |

(AM)

pg. 164 Anti-theft code



Anti-theft code

The radio features anti-theft circuitry. If the set is removed from the vehicle or if the battery power is disconnected, a special code must be entered to enable operation of the set.

Refer to the radio code card supplied with your vehicle or ask your retailer for the correct code.

When the car is parked with the ignition key removed, the anti-theft LED will flash.

To enter the code

After installation or when power has been disconnected, 'CODE' appears in the display when the set is switched on.

Enter the 4-digit code using the preset buttons. If the correct code is entered, the set is ready to use.

If you enter an incorrect code, you must enter the correct code again from the beginning.

Incorrect code

If an incorrect code has been entered, 'CODE Repeat' is displayed. Enter the correct code. After three unsuccessful coding attempts, the set will lock and remain locked for two hours. 'System Off' appears in the display.

During this waiting period:

- the battery must be connected
- the ignition key must be turned to position I
- the unit must be turned on

Make sure the headlights are turned off to help prevent battery drain (please refer to [page 24](#) for information on turning the headlights off). Enter the correct code after the two hours have elapsed.

pg. 165 Radio SC-900

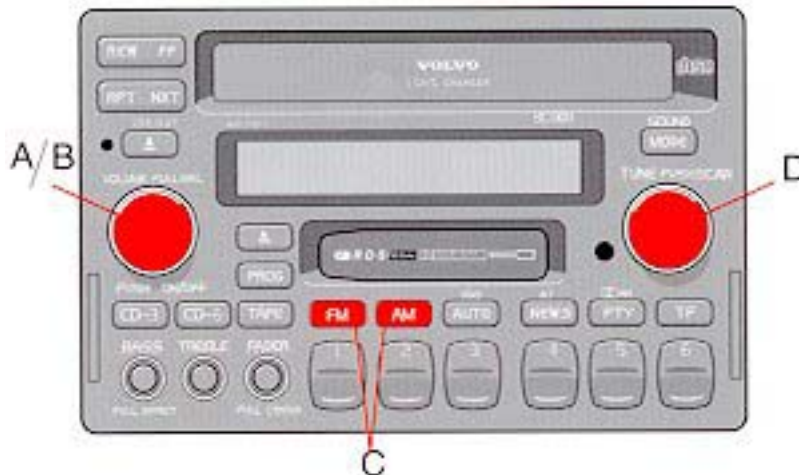
**A - On/off switch**

Press the button to switch the radio on/off.

B - Volume control

Turn this knob clockwise to increase the volume. The volume control is electronic and has no stop point.

C - Waveband selector

Press the "FM" or "AM" button to select the waveband you require. The name of the station and the waveband will appear in the display.

NOTE: There are three FM bands and one AM band. This allows you to store 3 x 6 FM stations and 6 AM stations. By pressing the **FM** button repeatedly you can switch between FM 1, FM 2 and FM 3.

D - Manual tuning knob

Turn this knob clockwise to select higher frequencies and counterclockwise for lower frequencies. Stored frequencies appear in the display.

pg. 166 Radio SC-900

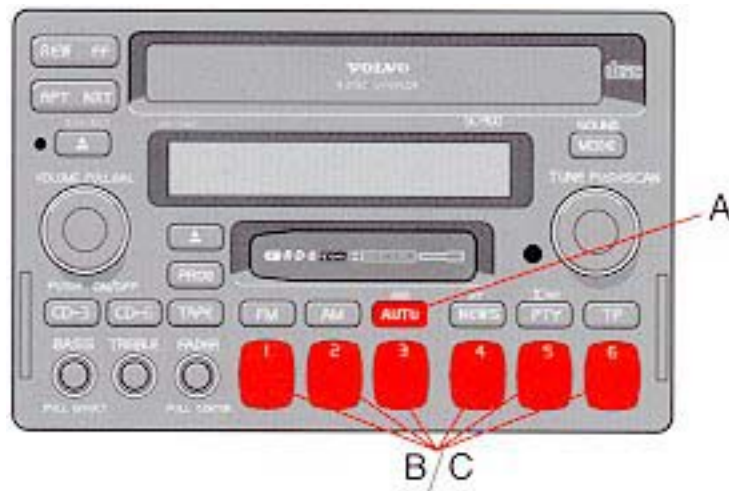

A - Automatic programming of stations

Please note that this function will not interfere with pre-stored stations on buttons 1-6. This function automatically seeks and stores up to 10 strong AM or FM stations in a separate memory. This is especially useful when travelling in areas where radio stations are unfamiliar.

1. Press and hold the 'AUTO' button for at least one second. A number of strong stations (max. 10) on the chosen waveband are now automatically stored in the memory. An 'A' now appears to the right in the display. If there are no sufficiently strong signals, 'No Station' is displayed.
2. Press the 'AUTO' button (for less than one second) if you want to change to one of the other auto-stored stations. A new autostored station will be selected each time the button is pressed.

B - Preset programming

1. Tune to the desired frequency.
2. Press a preset button (the audio will cut out) and keep it pressed until the audio comes on again (approximately two seconds).
3. The frequency is now stored on this preset button.

C - Preset buttons

To select a pre-programmed radio program, press the appropriate preset button. The stored program will appear in the display.

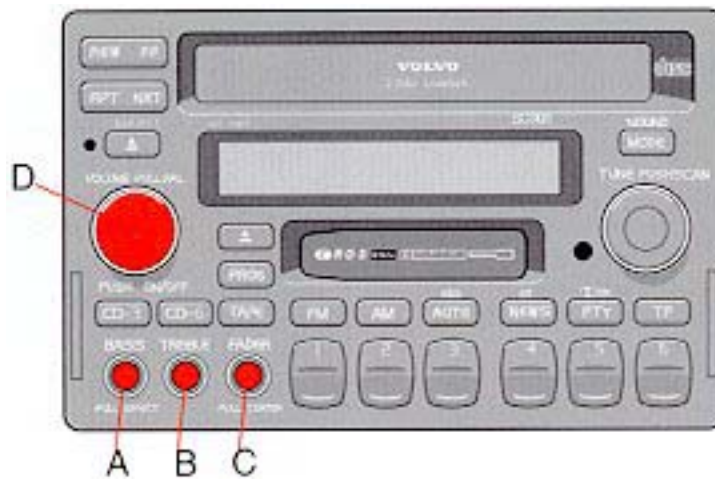

A - Bass control

Adjust the bass by pressing the button to extend the control and then turning it to the left (less bass) or to the right (more bass). A "detent" indicates "equalized" bass. Press the button back in when you have set the level.

B - Treble control

Adjust the treble by pressing the button to extend the control and then turning it to the left (less treble) or to the right (more treble). A "detent" indicates "equalized" treble. Press the button back in when you have set the level.

C - Fader - Balance control front/rear

Adjust front/rear speaker balance by pressing the button to extend the control and then turning it to the left (more sound from the front speakers) or to the right (more sound from the rear speakers). A "detent" indicates "equalized" balance. Press the button back in when you have set the level.

D - Balance control right/left

Pull out the 'volume' button and turn clockwise/counterclockwise to adjust the balance between the right/left speakers. The balance is shown in the display.



[Contents](#) | [Top of Page](#)

Radio Data System - RDS (also referred to as RBDS)

The SC-900 radio is equipped with an advanced system allowing information from broadcasters to be transmitted inaudibly together with the audio signal. This information is then decoded by the SC-900 and made available for several new and unique features. The RDS or Radio Data System operates in the FM band only, and the information transmitted is supplied by participating broadcasters. Volvo has no control over the accuracy of the data or information. Please refer to pages 168-173 regarding specific descriptions and operation of these functions. Volvo was among the first to pioneer this technology throughout Europe and it is slowly making its way to North America. Coverage by local broadcasters may be limited at this time, but as the technology and benefits grow, you will find the SC-900 radio ready to advantage of this system.



Automatic tuning

This feature may not apply in your area.

If you tune into a station using RDS, the frequency is displayed followed by the name of the station in letters. The AF function ensures that the radio automatically tunes into the most **powerful** transmitter for the selected program. Keep the **FM** button pressed down for at least two seconds. 'AF Switch OFF' appears in the display for two seconds. If you want to switch on the AF function, press the **FM** button for less than one second. 'AF Switch ON' then appears in the display.

'**AF Switch ON**'- Automatic station tracking is activated

'**AF Switch OFF**'- Automatic station tracking is deactivated

A- Station seek up/down

Press the left side of the station seek button to seek for lower frequencies and the right side for higher frequencies. The radio seeks the next audible station and stops there. Press the button again to continue searching. If the **TP** button is depressed, the station seek function will only seek stations which broadcast this particular type of program. Press the button to switch off this function.

B - Scanning

Press this button to listen to each station for five seconds. If the unit is in tape or CD mode, each track will play for ten seconds.

pg. 169 Traffic Program



Traffic Program (TP)

This feature may not apply in your area and only functions with FM broadcasts. Please refer to the RDS information on [page 168](#). By pressing the TP button (for less than 1 second), RDS stations broadcasting traffic information can be heard. 'TP' is displayed when this function is switched on. If the unit is in tape or CD mode when the radio receives traffic information, the respective function will be interrupted and the announcement is received at the volume selected for traffic information. As soon as the announcement is over, the previous volume will be restored and the tape or CD will start to play again.

- Traffic information can only be received when TP is displayed.
- If TP is flashing, it means that either no traffic information is being broadcast by the current transmitter or the signal is too weak.
After approximately 70 seconds, an audible signal will be heard, indicating that you should change to a stronger TP transmitter. To turn off this signal:
 - Turn the radio off
 - Press and hold down the **TP** button and turn the radio on. By pressing the **TP** button again, you can turn the TP alarm on or off.
 The radio will function normally again after 5 seconds.
- Press the TP button for less than 1 second if you want to stop listening to a traffic announcement.

pg. 170 News



NEWS

This feature may not apply in your area and only functions with FM broadcasts. Please refer to the RDS information on [page 168](#). Press the **NEWS** button to seek a station broadcasting news programs.

If you press the **NEWS** button for less than 1 second while tuned to a news station, the radio will switch back to the previously selected station.

pg. 171 Program type - PTY



Program type

The 'PTY' function enables you to select different types of program. If you want to search for a specific program type:

1. Press the **PTY** button for less than 1 second. The program type of the currently selected radio station will be displayed.
2. By turning the manual tuning knob, it is possible to scroll through the different program types.
3. When you have found a program type you want to select, press the manual tuning knob to begin the search. During the search, the chosen program type will flash in the display.
4. If the radio finds a station of the selected program type, it will tune in this station and the station's name will appear in the display. If no station with the selected program type is found, 'No PTY'

will appear in the display for five seconds and the radio will revert to the previous station.

For general information on RDS functions, please refer to [page 168](#).

pg. 172 PTY preset buttons



PTY preset buttons

Program types are factory-preset as follows:

- Button 1 - Top 40
- Button 2 - Classical
- Button 3 - News
- Button 4 - Rock
- Button 5 - R&B
- Button 6 - Country

These settings can be reprogrammed according to your preferences. To change the default settings:

1. Press the **PTY** button for less than 1 second to enter the PTY preset programming mode.
2. Turn the manual tuning knob to display different program types.
3. Press one of the preset buttons for at least 2 seconds to store your choice of program type on that button.

Using the PTY preset buttons

Press one of the preset buttons to select a program type. The program type stored on that button will be displayed and a station broadcasting that type of program will be selected. Press the same button again to select a new station broadcasting the same type of program.

For general information on RDS functions, please refer to [page 168](#).

pg. 173 Volume setting. Radio text

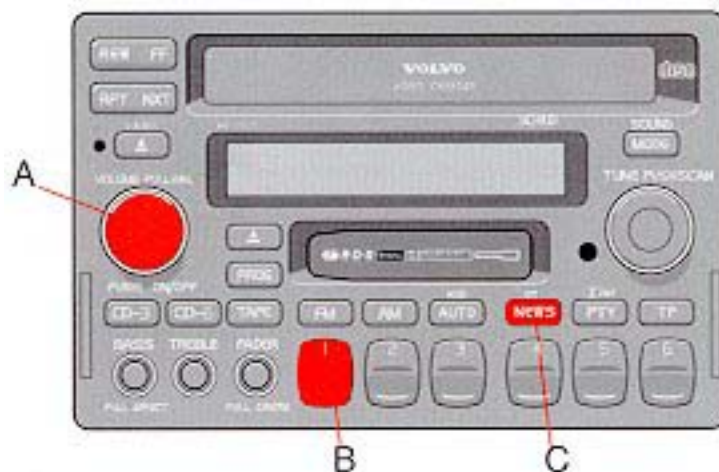

A - Volume for traffic information

If you change the volume during a traffic announcement, this volume setting will be stored automatically and used for future traffic information.

B - Automatic volume control

The Auto Volume function adjusts both the volume and frequency response according to vehicle speed. To enable/disable (switch on or off) this function:

- Hold down **preset button 1** while switching on the radio. The current setting (ON or OFF) will be displayed.
- Press preset button 1 to toggle between ON and OFF. After five seconds, the display will return to normal and your selection (ON or OFF) will be stored.

C - Radio Text (RT)

Certain RDS stations broadcast general information on programs, music, weather, in text form. This information can be displayed by press the NEWS button for approximately 2 seconds. If no text information is available "No radio text" will be displayed.

WARNING! The Radio Text function should not be used by the driver while the car is in motion as this could create a traffic hazard.

For general information on RDS functions, please refer to [page 168](#).



[Contents](#) | [Top of Page](#)

pg. 174 Cassette deck

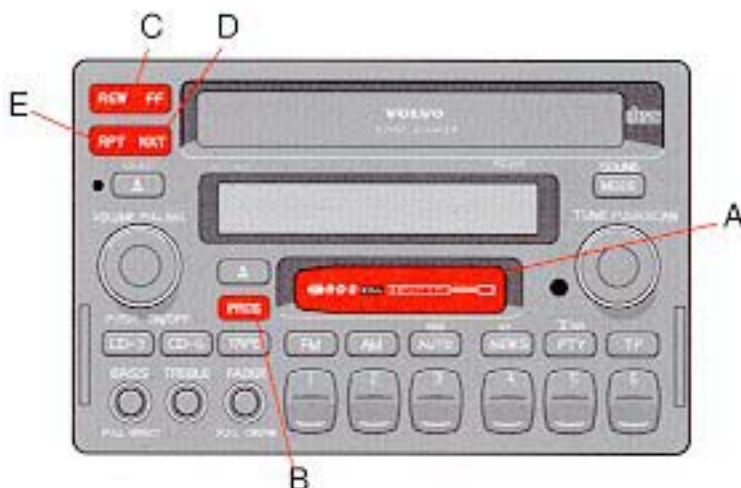

A - Cassette slot

Insert the cassette with the open side to the right (side 1 or A upwards). When the cassette is inserted, the radio is automatically switched off and the cassette will start to play. 'Tape side A' or 'Tape side B' will appear in the display to indicate which side of the tape is being played. When one side of the tape has been played, the unit will automatically play the other side (auto-reverse). The cassette can be ejected up to five minutes after the key has been taken out of the ignition.

B - Reversing the tape (PROG)

Press this button if you want to play the other side of the tape. The side of the tape being played will be displayed.

C - Fast winding

The tape is advanced with 'FF' and rewind with 'REW'. 'FF' (fast forward) or 'REW' (rewind) appear in the display when fast winding. Fast winding can be stopped by pressing the button again.

D - Next track

If you press the 'NXT' button, the tape will automatically advance to the next track. There must be a gap (no audio sound) of approx. 5 seconds between songs for this function to operate.

E - Previous track

If you press the 'RPT' button, the tape will automatically rewind to the previous track. There must be a gap (no audio sound) of approx. 5 seconds between songs for this function to operate. 'NXT' and 'RPT' flash when the tape is either fast forwarding or rewinding.

NOTE: This radio is equipped with background FF/REW and NXT/RPT functions. This means that you can listen to the radio or a CD by selecting either of these modes while a tape is being wound.

pg. 175 Cassette deck

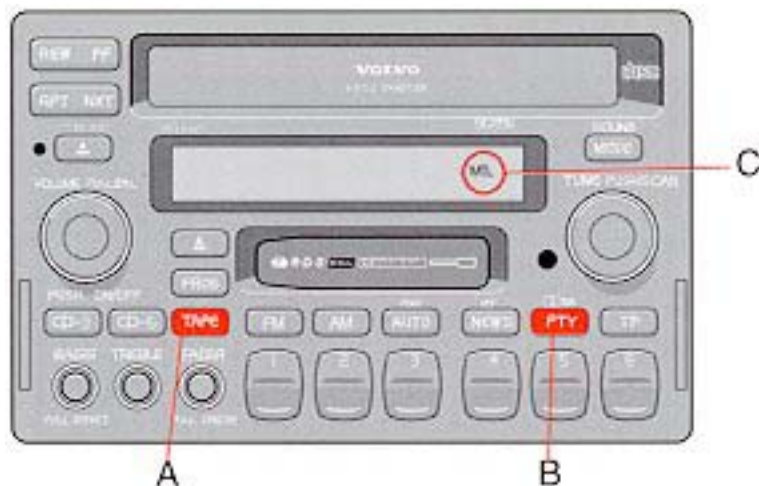
**A - Pause**

If you press the 'TAPE' button, the tape will stop, the sound will cut off and 'PAUSE' will appear in the display. Press the 'TAPE' button to restart the tape.

B - Dolby B noise reduction

Press this button if you are playing a tape which has been recorded with the Dolby B noise reduction system. The Dolby symbol  appears in the display.

C - Metal tapes

If you are playing a metal tape (CrO₂) 'MTL' appears in the display.

pg. 176 Cassette deck

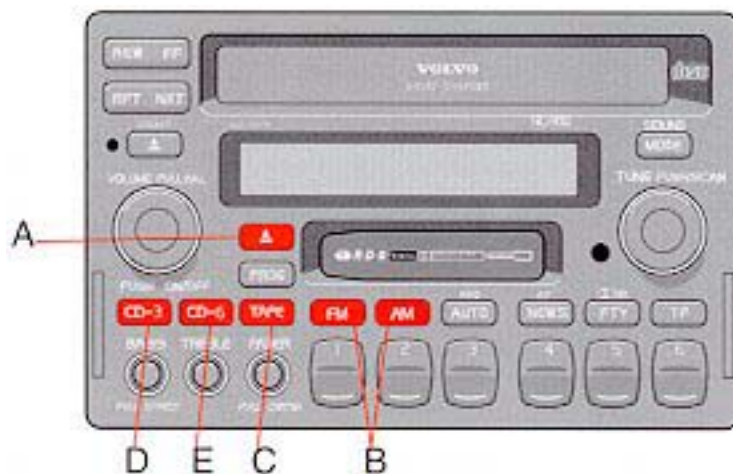
**A - Cassette eject**

If you press this button, the tape will stop and the cassette will be ejected. The radio, CD 3 player or CD 6 changer will be automatically switched on depending on which mode was used before the tape was played.

B - To return to the radio mode

Press the **FM**, **AM** or **AUTO** button to return to the radio mode. The radio will then be switched on without the cassette being ejected.

C - To return to the tape mode

If the cassette deck has been switched off, but the cassette has not been ejected, you can return to tape mode by pressing the '**TAPE**' button.

D - To return to the CD 3 mode

If the CD player has been switched off, but the cartridge has not been ejected, you can return to the CD 3 mode by pressing the **CD 3** button

E - To return to the CD 6 changer mode

If the CD 6 changer has been switched off, you can return to the CD 6 changer mode by pressing the **CD 6** button.



[Contents](#) | [Top of Page](#)

pg. 177 CD 3 player

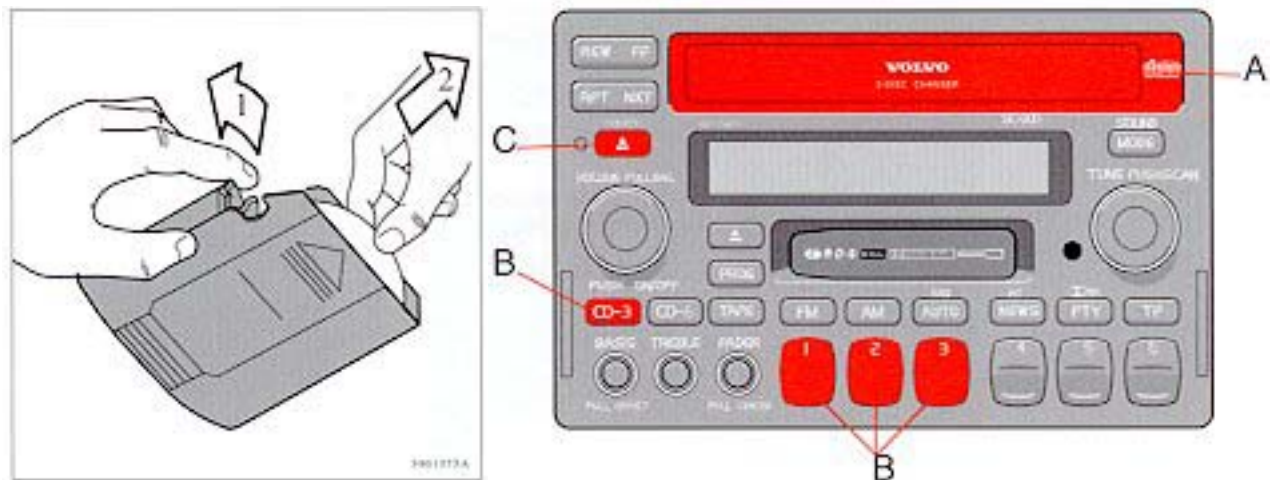
**A - CD 3-slot**

When you insert a cartridge, the unit will automatically switch modes and the CD 3 will start playing. A cartridge can be inserted even if the unit is switched off. **To operate:**

- Insert the discs into the cartridge, label side up.
- Insert the cartridge in the CD 3 slot, in the direction indicated by the arrow on the top side of the cartridge.
- Eject the cartridge by pressing button C.
- Remove the discs from the cartridge by pulling the lock tab for the disc you wish to remove (1). Carefully pull the disc out of the cartridge (2).

B - CD 3 player mode - on

Press the **CD 3** button to activate the CD play en The last track to be played will start playing. If there is no disc in the cartridge, the cartridge will automatically be ejected. Choose disc 1, 2 or 3 with the preselect buttons 1-3.

C - CD 3 eject

If you press this button, the CD 3 player will stop and the cartridge will be ejected. The radio, cassette deck or CD 6 changer will automatically be switched back on, depending on which function was used last.

NOTE: Do not pull the cartridge while it is in operation, as this may damage the mechanism.

pg. 178 CD 3 player



A- Music search

Press the 'FF' or 'REW' buttons to search within a track. While the button is pressed, the playing time for this track is displayed.

B - Changing tracks

Press 'NXT' to move forward to the next track, 'RPT' to repeat the previous track or turn the manual tuning knob. The selected disc number and track number will appear in the display.

C - Playing-time display

When the 'FF' or 'REW' buttons are pressed, the playing time for the current track is displayed for 5 seconds.

pg. 179 CD 3 player

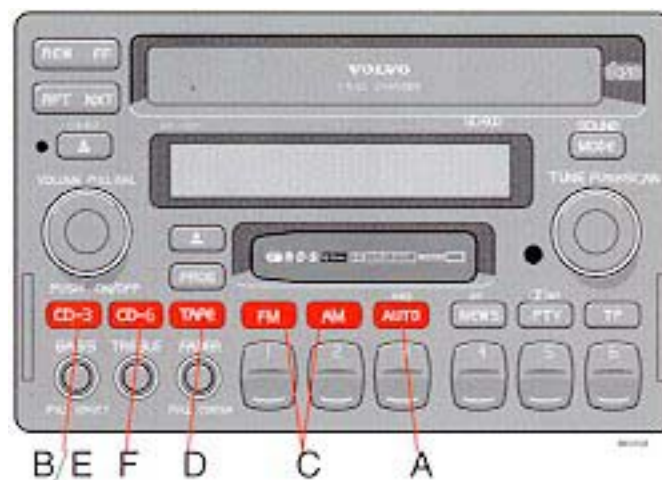

A- Random choice

Press 'RND' to activate the random function. The unit will play the tracks on the disc in a random* order. 'RND' (random) appears in the display while the function is on.

* The random function may cause a disc to be played more than once before playing through all discs.

B - Pause

If you press the **CD 3** button, the CD 3 player stops, the sound is switched off and 'Pause' appears in the display. Press the CD 3 button again to restart the CD 3 player.

C - To return to the radio mode

Press the **FM** or the **AM** button.

D - To return to the tape mode

If a cassette is already inserted, you can return to tape mode by pressing the '**TAPE**' button.

E - To return to the CD 3 mode

If the CD 3 player has been switched off but the cartridge has not been ejected, you can return to the CD 3 mode by pressing the CD 3 button.

F - To return to the CD 6 changer mode

If the CD 6 changer has been switched off, you can return to the CD changer mode by pressing the **CD 6** button.



[Contents](#) | [Top of Page](#)

pg. 180 CD 6 changer (retailer option)

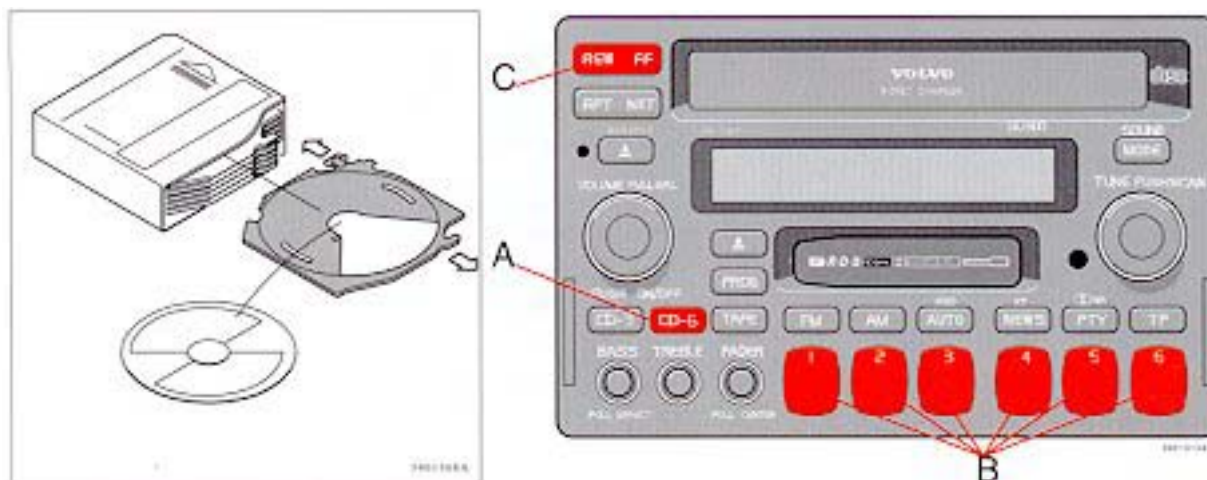

CD 6 changer

The CD 6 changer, which is available separately, is loaded with a cartridge which can accommodate 6 discs. If no CD 6 changer is connected, pressing the CD 6 button will have no effect.

To operate:

- Pull out the tray and place the disc on it, label up. Insert the tray into the cartridge.
- Insert the cartridge in the CD changer in the direction indicated by the arrow on the top side of the cartridge, and close the cover.
- Remove the discs from the cartridge by pulling out the trays.

A- CD 6 changer - on

Press the 'CD 6' button to activate the CD 6 mode. The CD 6 changer will start playing the last disc and track to be played. If the CD 6 changer cartridge is empty, 'No Disc' will appear in the display. If a selected disc does not exist, the disc number and 'CD X-00' (X is the disc number) will appear in the display, and the next disc will automatically be selected. If there is no cartridge in the CD 6 changer, 'No Magazine' will appear in the display.

B - Disc number selector

Press one of the preselect buttons (1-6) to select the disc number required. The selected disc number and track number will be displayed.

C - Music search

Press the 'FF' or 'REW' buttons to search within a track. While the button is pressed, the playing time for this track is displayed.

pg. 181 CD 6 Changer (retailer option)



A - Changing the selected track number

Press 'NXT' to move forward to the next track, 'RPT' to repeat the previous track or turn the manual tuning knob. The selected disc number and track number will be displayed.

B - Playing-time display

When the 'FF' or 'REW' buttons are pressed, the playing time for the current track is displayed for 5 seconds.

pg. 182 CD 6 Changer (retailer option)

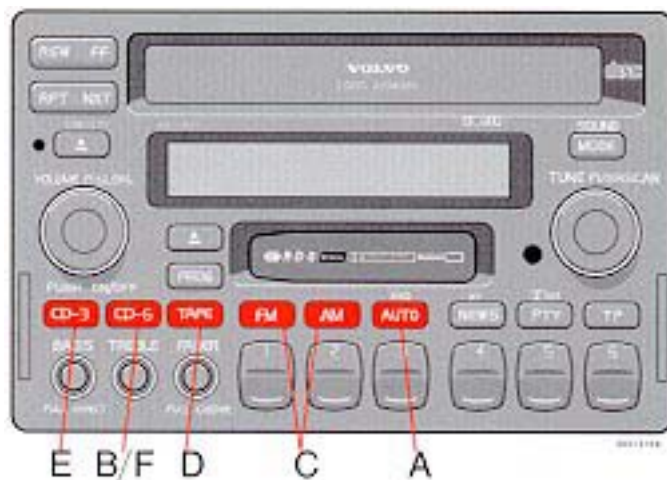

A - Random choice

Press 'RND' to activate the random function. Randomly selected tracks will play from randomly selected discs. 'RND' (random) appears in the display while the function is on.

B - Pause

If you press the CD 6 button, the sound is switched off and 'Pause' appears in the display. Press the CD 6 button again to restart the CD 6 changer.

C - To return to the radio mode

Press the **FM** or the **AM** button.

D - To return to the tape mode

If a cassette is already inserted, you can return to tape mode by pressing the '**TAPE**' button.

E - To return to the CD3 mode

If the CD 3 player has been switched off but the cartridge has not been ejected, you can return to the CD 3 mode by pressing the CD 3 button.

F - To return to the CD6 changer mode

If the CD 6 changer has been switched off, you can return to the CD 6 changer mode by pressing the CD 6 button.



[Contents](#) | [Top of Page](#)

pg. 183 Dolby Pro Logic Surround Sound (certain models)

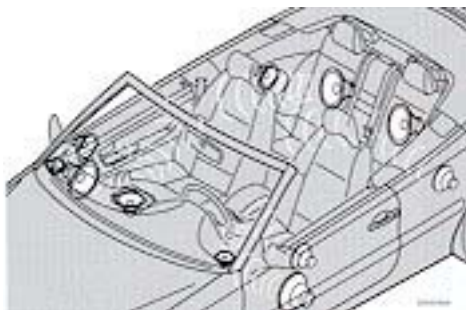

Dolby Pro Logic Surround Sound

Together with a center speaker mounted at the center of the dash, Dolby Pro Logic Surround Sound offers much clearer and more realistic sound.

Through a connection to a special decoder (optional on certain models), as well as a center speaker (option), the normal left-right stereo channels are divided into left-center-right. In addition, "surround" sound can be created from the car's rear speakers.

Most modern discs are recorded so that vocals are heard in the center foreground, while the orchestra is heard across the entire left-right range, as well as from behind.

A- Engaging Surround Sound

Press the 'MODE' button to engage the center speaker and the surround unit. The mode selected will be displayed.

"3 CH" = center speaker also engaged.

"Dolby Pro Logic" = Dolby Pro Logic engaged with surround effect from rear speakers*.

B - Center speaker volume control

First press the button in slightly to pop it out, then pull the button out completely and turn it to adjust the volume of the center speaker.

C - Surround effect volume control

First press the button in slightly to pop it out, then pull the button out completely and turn it to adjust the volume level from the rear speakers (Dolby Pro Logic only).

Diversity antenna (dual antenna system)

Certain models are equipped with the optional Diversity dual antenna system. Two antennas are connected to the radio through two separate sockets, allowing for better reception and reducing the effects of static or multipath distortion of FM reception.

Speakers behind rear seat backrest (option)

The button on the rear console is used to turn the optional speakers behind the rear seat backrest on or off.

* Will not function in Radio mode (FM or AM).

pg. 184 Other settings



A - Settings for individual markets

Settings for individual markets are usually adjusted in the factory or at the retailer. If you need to change this setting: switch off the radio; hold down preset button 5 (B); switch on the radio (A) and press preset button 5 again until the relevant market (US, AUS or EU) appears.

pg. 185 Technical specifications

SC-900

Output (center speaker):	1 x 25 W
Output (supplementary amplifier):	4 x 100 W. 10% dist
Frequency range:	30 - 20,000 Hz
S/N:	min.74 dB ref. to 1 W
Output impedance:	4 Ohms
System voltage:	12 V, negative ground

Radio

Volvo's SC-900 stereo system contains a microprocessor-controlled radio receiver with PLL (Phase Lock Loop), designed for RDS (Radio Data System). The SC-900 must be connected to a separate power amplifier.

Frequency range:

AM 530 - 1710 kHz
FM 87.9 - 107.9 MHz

Sensitivity:

AM 2.2 μ V
FM 1.1 μ V
Stereo separation: 35 dB

Cassette deck

4-track, 2-channel stereo
Full logic electronic tape transport

Tape speed: 4.76 cm/sec.
Channel separation: 40 dB
Frequency range: 30 - 15,000 Hz
S/N (120 μ V): 50 dB
Wow and Flutter: < 0.07%
Pinch-off

Alert

'Alert!' will be displayed when emergency information is broadcast. This function is used to warn drivers in the event of a serious accident or disaster situation.

'Dolby' and the  symbol are the trademarks of Dolby Laboratories Licensing Corporation. The Dolby noise reduction system is manufactured under license from Dolby Laboratories Licensing Corporation.

Dolby Pro Logic is the trademark of Dolby Laboratories Licensing Corporation. The Dolby Pro Logic Surround System is manufactured under license from Dolby Laboratories Licensing Corporation.

CAUTION: The supplementary amplifier may be mounted under the front passenger's seat. If the floor of the car has become soaked for any reason, do not turn on the radio. This would cause damage to the amplifier. Contact a Volvo retailer.



[Contents](#) | [Top of Page](#)

Cassettes

- Store cassettes in their cases.
- Do not touch the tape surface with your fingers.
- Tapes should not be exposed to direct sunlight or extreme temperatures.
- Keep tapes away from oil, grease and other contaminants.
- For optimal tape deck performance Volvo does not recommend the use of C-120 tapes.
- Take up slack using a pen or a pencil before inserting a cassette in the cassette slot.

Cassette cleaning

We recommend the use of the Volvo Cleaning Cassette available as a genuine Volvo accessory. Regular use improves sound quality, cleans vital parts and prevents tape tangle.

Compact disc care

- Before using a new disc for the first time, remove any burrs in the center/outer edge by running the stem of a pen or similar object around the hole/edge of the disc.
- Use high quality discs only.
- Keep the discs clean. Wipe them with a soft, clean, lint-free cloth, working from the center outwards. If necessary, dampen the cloth with a neutral soap solution. Dry thoroughly before using.
- Never use cleaning spray or antistatic liquid. Use only cleaners specifically made for CD's.
- Use discs of the correct size only (3.5" discs should never be used).
- Do not put tape or labels on the disc itself
- Volvo does not recommend the use of plastic outer rings on the disc.
- Condensation may occur on discs/optical components of the changer in cold winter weather. The disc can be dried with a clean, lint-free cloth. Optical components in the CD changer may, however, take up to one hour to dry off.
- Never attempt to play a disc which is damaged in any way.
- When not in use, the discs should be stored in their covers. Avoid storing discs in excessive heat, direct sunlight or dusty locations.

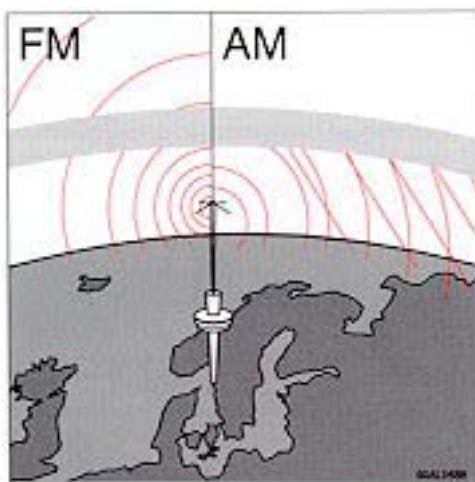

Sending signals

The FM waves do not follow the earth's surface nor do they bounce off the atmosphere. For this reason their range is limited. The AM waves follow the earth's surface and reflect against the atmosphere, giving them a wide range.



Weak reception (fading)

Because of the limited range of the FM senders and the fact that these waves are very reflective, this problem usually occurs with FM reception. If the sender is blocked by buildings or mountains, static can result.

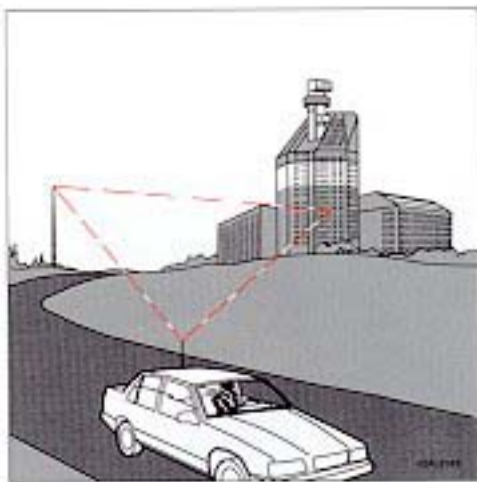

Static

The reason why FM but not AM is audible in covered parking areas, under bridges, etc. is that FM signals reflect against solid objects such as buildings. Because these waves are very reflective, static can result. This static is the result of the reflected signal and the direct signal reaching your antenna at slightly different times causing a cancellation of all signals. This problem occurs largely in built-up areas. Your car is equipped with a dual antenna system which helps alleviate this problem.

pg. 188 Audio systems, general information



Cross modulation

If you listen to a weak station in the vicinity of a stronger one, both stations may be received simultaneously. If the car is moved a short distance, the weaker signal may be heard more clearly.

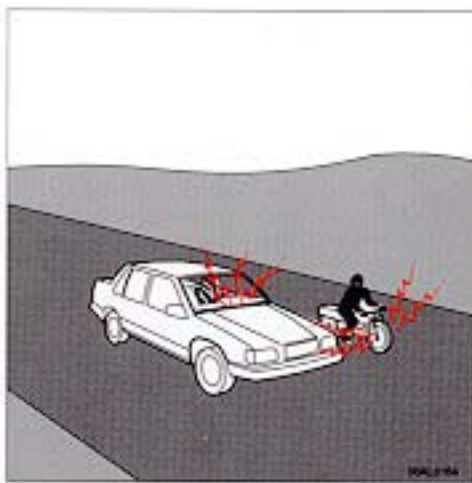

FM - reasons for distortion

FM is affected by the electrical systems of nearby vehicles, especially those without suppression. The distortion increases if the station is weak or poorly set. The FM reception is not as sensitive to electrical disturbance as AM.



AM - reasons for distortion

AM reception is sensitive to electrical disturbances such as power lines, lightning, etc.

pg. 189 Audio systems. General information

FM stereo reception

Stereo reception places very high demands on the signal quality which means the type of distortions previously mentioned become even more obvious. The signal strength needs to be stronger for good stereo reception and this limits the effective range of the sender.

We hope that this information proves to be useful and provides you with a better understanding of the problems related to car radio reception.

Reception conditions are not always optimum and this is, of course, beyond our control. However, we have endeavored to make the Volvo Audio System of a quality that will enable you to enjoy the best possible reception no matter what the reception conditions may be.

Radio antennas

NOTE: Always lower the antenna when using an automatic car wash or entering a garage.

The antenna should be cleaned at least every 10,000 miles (16,000 km) or more frequently if needed. Use WD40* for cleaning. Spray the antenna with WD40 and wipe it clean and dry with a rag. Spray it again. Lower and raise the antenna. Wipe it clean and dry again. Lower and raise the antenna 4-6 times. Make sure it is dry and free from dirt or lubricating oil.

* Avoid spraying WD40 on any painted surfaces as this could cause damage to the paint.



[Contents](#) | [Top of Page](#)

A

ABS	17
Air conditioning	35
Air mix	33
Airbag (SIPS)	8
Airbag (SRS)	4
Alarm	44
Ambient temperature sensor	25
Anti-lock Brake System (ABS)	17, 19, 72
Ashtrays	31
Audio systems	
General information	186
SC-813	134
SC-816	147
SC-900	163
Auto-dim (rear-view mirror)	48
Automatic daytime running lights	24
Automatic transmission	62, 63, 64, 65, 129
Driving mode selector	64
Automatic transmission fluid	119, 126

B

Battery	74, 130
Battery drain - avoiding	54
Battery maintenance	124
Booster cushion	12
Brake failure warning light	17, 18
Brake fluid	118, 126
Brake fluid warning light	18
Brake system	72
Brake warning light	17
Break-in period	58
Bulb failure warning	17, 19
Bulbs	130

[Bulbs - replacing](#) 87

C

[Capacities](#) 129

[Catalytic converter](#) 71

[Central locking button](#) 37

[Chains \(snow\)](#) 79

[Changing a wheel](#) 84

[Child booster cushion](#) 12

[Child Restraint Anchorages](#) 10

[Child safety](#) 12

[Cleaning the convertible top](#) 105

[Climate control systems](#) 33

[Clock](#) 16

[Clock - resetting](#) 25

[Clutch fluid](#) 118

[Convertible top - cleaning](#) 105

[Convertible top - electrically operated](#) ... 23,40

[Convertible top - manually raising](#) 100

[Coolant - checking/changing](#) 122

[Coolant level sensor](#) 19

[Coolant level warning light](#) 17

[Cooling system](#) 66,128

[Courtesy lights - front](#) 49

[Cruise control](#) 29

D

[Daytime running lights](#) 20,24

[Demister - rear window](#) 23

[Dimensions](#) 131

[Distributor ignition system](#) 128

[Diversity antenna](#) 183

[Doors and locks](#) 42

[Drive belt](#) 120

[Driving economy](#) 60

E

ECC - Electronic Climate Control	34, 35
Electrical system	66, 130
Electrically heated front seats	30
Electrically operated convertible top	23, 40
Electrically operated front seats	46, 47
Electrically operated windows	36
Emergency towing	68
Emergency warning flashers	23
Engine	127
Engine compartment	123
Engine oil	116, 117, 126
Engine oil - checking/changing	116
Engine oil pressure	17

F

Fog light - rear	17, 22
Fog lights - front	22
Front courtesy lights	49
Front fog lights	22
Front seats	46
Front seats - heated	30
Front seats - memory function	46
Front suspension	128
Fuel gauge	16
Fuel level	17
Fuel requirements	58
Fuel system	128
Fuel tank cover - opening	15, 37, 59
opening manually	99
Fuses	93, 94, 95
Fuses - replacing	93

G

Gas tank cover - opening	15, 37, 59
opening manually	99, 100
Gasoline	59

Generator	17, 130
Generator warning light	18

H

Hand brake	30
Handling	67
Hazard warning flashers	23
Headlight wiper blades - replacing	98
Headlights	20
Heated front seats	30
Heated side-view mirrors	23
Heating	35
Heating and air conditioning	33
High beams	17
Hoisting the car	112
Hood	51

I

Ignition switch	21
Instrument illumination	22
Instruments	14, 15

J

Jack	53, 84, 85
Jump starting	70

K

Keyless entry system	43
Keylock	61
Keys	42
Kick-down	63

L

Label information	108
---	---------------------

Lifting the car	112
Locks	42
Long distance trips	75
Long load storage	50
Lubrication	115
Luggage racks - trunk-mounted	67
Lumbar support	46

M

Maintenance schedule	110
Maintenance service	109
Malfunction indicator lamp	17, 18
Manual transmission	62, 129
Manual transmission fluid	126
Manually raising convertible top	100
Memory function - front seats	46
Mirrors - rear/side view	48

O

Occupant safety	13
Octane rating	58
Odometer	16
Oil (engine)	116, 117, 126
Oil pressure warning light	18
On-call	132

P

Paint touch-up	102
Parking brake	17, 30
Parking brake reminder light	18
Parking lights	20
Polishing	105
Power seats	46, 47
Power steering fluid	118, 126

R

Radio

General information	186
SC-813	134
SC-816	147
SC-900	163
Radio Data System - RDS	168
Reading lights	49
Rear fog light	17, 22
Rear seat speakers - turning on/off	37, 183
Rear suspension	128
Rear window demister	23
Rear/side-view mirrors	48
Refueling	59
Remote control (central locking system)	43
Remote keyless entry system	43
Replacing bulbs	87, 88, 89, 90, 91, 92
Replacing fuses	93
Reporting Safety Defects	13
Road Assistance	132
Roadholding	67
Roll Over Protection System (ROPS)	9, 17

S

Safety defects (reporting)	13
Seat belt maintenance	13
Seat belts	2, 3, 11
Automatic Locking Retractor	11
Emergency Locking Retractor	11
Seat belts - cleaning	106
Seats	46
Seats - heated	30
Service reminder indicator	17, 19
Servicing	112, 113, 114
Shift lock	61, 63
Shiftlock release (override)	99
Side Impact Protection System (SIPS)	8
Side-view mirrors - heated	23

SIPS	8
Snow chains	79
Snow tires	79
Spare tire	86
Spare tire (sedan)	53
Spark plugs	128
Spark plugs - replacing	128
Speakers (rear seat) - turning on/off	37, 183
Specifications	125
SRS	5, 6, 7
SRS (airbag)	4
SRS diagnostic system	19
SRS warning light	5, 17, 19
Starting the engine	61
Steering wheel adjustment	32
Steering wheel lock	21
Storage compartments	55
Studded tires	79
Supplemental Restraint System (SRS)	4

T

Tachometer	16
Temperature gauge	16
Temporary spare tire	86
Three-way catalytic converter	71
Tire pressure	80
Tires - changing	84
Towing	68, 69
Towing a trailer	73
Traction Control System (TRACS)	17, 19, 23
Trailer towing	73
Trip computer	23, 26, 27, 28
Trip odometer	16
Trunk - opening/locking	52
Trunk light	53
Turn signals	17, 20

U

[Uniform tire quality grading](#) 81
[Upholstery - cleaning](#) 106

V

[Vanity mirrors](#) 49
[Vehicle Identification Number \(VIN\)](#) 108
[Vehicle loading](#) 129
[Volvo On Call](#) 132

W

[Warning flashers](#) 23
[Warning lights](#) 18, 19
[Warranty](#) 109
[Washer fluid level](#) 17
[Washer fluid reservoir](#) 121
[Washing](#) 104, 105
[Waxing](#) 105
[Wheel changing](#) 84, 85
[Wheels and tires](#) 78
[Wind deflector](#) 41
[Windows - electrically operated](#) 36
[Windshield washer nozzles](#) 121
[Windshield washers/wipers](#) 21
[Windshield wiper blades - replacing](#) 97
[Winter driving](#) 74



[Contents](#) | [Top of Page](#)

Inside back cover

WARNING!

Detergents and solvents

Do not use gasoline containing lead or benzene as a detergent or solvent. Both lead and benzene are toxic and may be hazardous to your health.

Installation of optional equipment/use of mobile telephones

Incorrectly installed optional equipment, alarm systems or the use of mobile telephones which are not connected to a suitable antenna can cause faults in the car's electronic control systems. Your car is equipped with an accessory connector located under the dashboard on the driver's side. Please consult your Volvo retailer if you have any questions before connecting accessory or optional equipment to the vehicle's electrical system.

Carbon monoxide

Carbon monoxide is a poisonous, colorless and odorless gas which is present in all exhaust gases. If you ever smell exhaust fumes inside the vehicle, make sure the passenger compartment is ventilated and immediately return the vehicle to your retailer for correction.

Never sit in a parked or stopped car for any extended amount of time, nor have it unattended while the engine is running.

Never operate the engine in confined, unventilated areas.

Back cover

The following should be checked regularly: *

1 Washer fluid reservoir should be filled with water and solvent (wintertime: windshield washer anti-freeze). See [page 121](#).

2 Coolant level should be between the expansion tank marks. Mixture: 50% antifreeze and 50% water. See [page 122](#).

3 Power steering - When cold, the level must not be above the

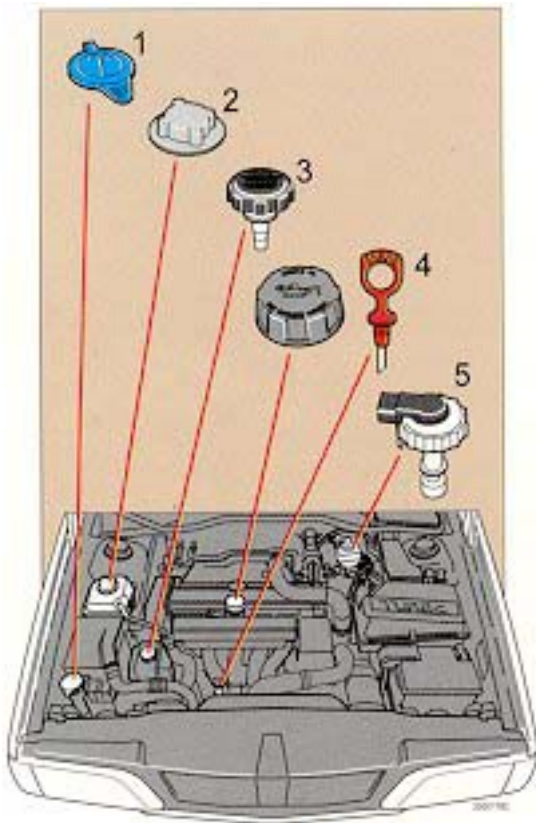

COLD mark and when hot it must not be above the HOT mark. Top up if the level drops to the ADD mark with ATF fluid. See [page 118](#).

4 Engine oil level should be between the dipstick marks. The distance between the marks represents approx. 1.6 US qts (1.5 liters) or 1 US qt. (1 liter) on certain models. See [page 116](#).

5 Brake fluid - check, without removing the cap, that the level is above the MIN mark. Use brake fluid DOT 4+. See [page 118](#).

* Engine oil should be checked each time the car is refuelled.

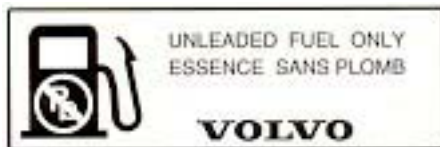

Octane rating, see [page 59](#).

Tire pressure, see label located on the rear edge of the right front door.

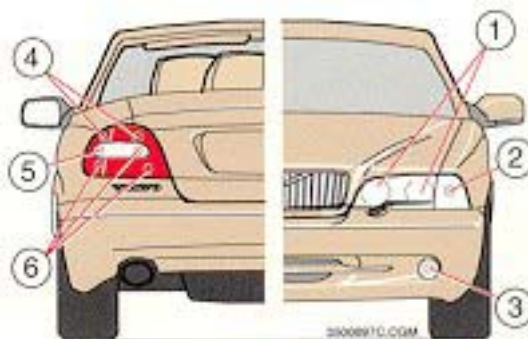

Bulbs	Power	Socket	US no.
1	55 W	-	H7
2	30/7 W	BA 15s	3357NA
3	55 W	PK 22s	H3
4	5 W	BA 15s	67
5	21 W	BAU 15	-
6	21 W	BA 15s	1156

See [pages 87-89](#) for more detailed information.



TP 4230/1 (Canada & USA) 2000.11.97 Printed in Sweden,  Graphic systems AB, Göteborg 1997



[Contents](#) | [Top of Page](#)