

## Engine

Base Part Number: Base Part Number: 6L084

### Special Tool(s) / General Equipment

 17063	100-010 Remover, O-Ring Seal
 14010	204-017 Installer, Wheel Hub Bearing Cup
 E133912	303-1565 Alignment Tool, Camshaft TKIT-2010C-FLM
 ES21202	303-499 Socket, Spark Plug
 IA21213	303-509 Remover, Vibration Damper Hub
 303748	303-748 Locking Tool, Crankshaft TKIT-2010B-FLM TKIT-2010B-ROW
Plastic Scraper	
Round-Ended Steel Rule	

**Materials**

Name	Specification
Motorcraft® High Performance Engine RTV Silicone TA-357	WSE-M4G323-A6
Flange Sealant CU7Z-19B508-A	WSS-M2G348-A11
Motorcraft® Metal Surface Prep Wipes ZC-31-B	-

1. **NOTE:** Make sure that a new component is installed.

**NOTE:** New crankshaft rear seal carriers are supplied with an alignment sleeve which must be removed after installation.

Torque: 89 lb.in (10 Nm)

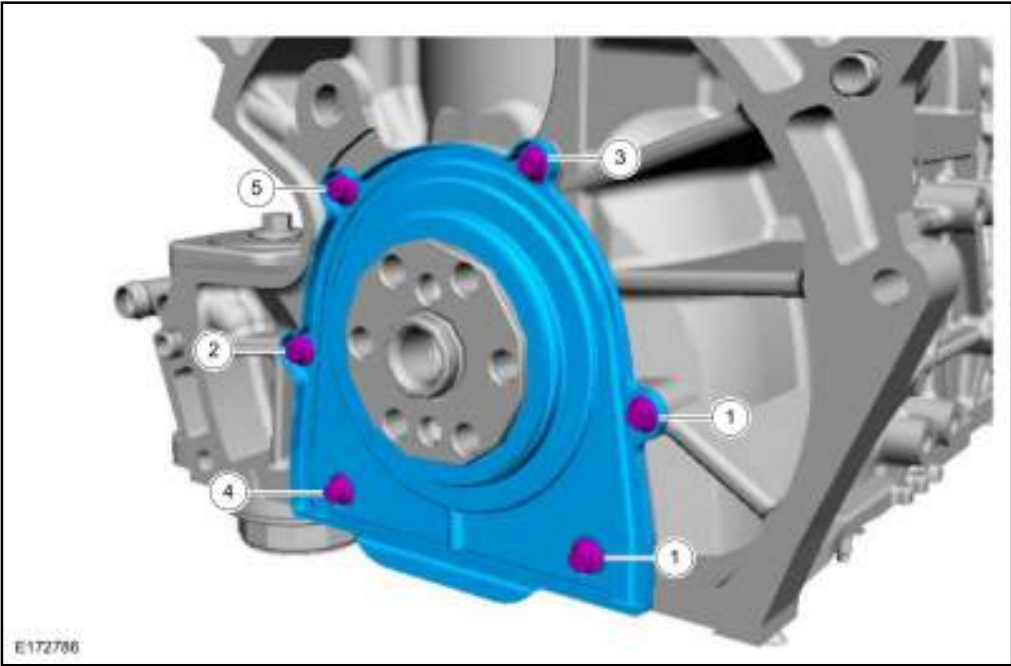

- 1. Flat faced sprocket – requires new friction washer.
- 2. Laser etched sprocket – does **NOT** require friction washer.

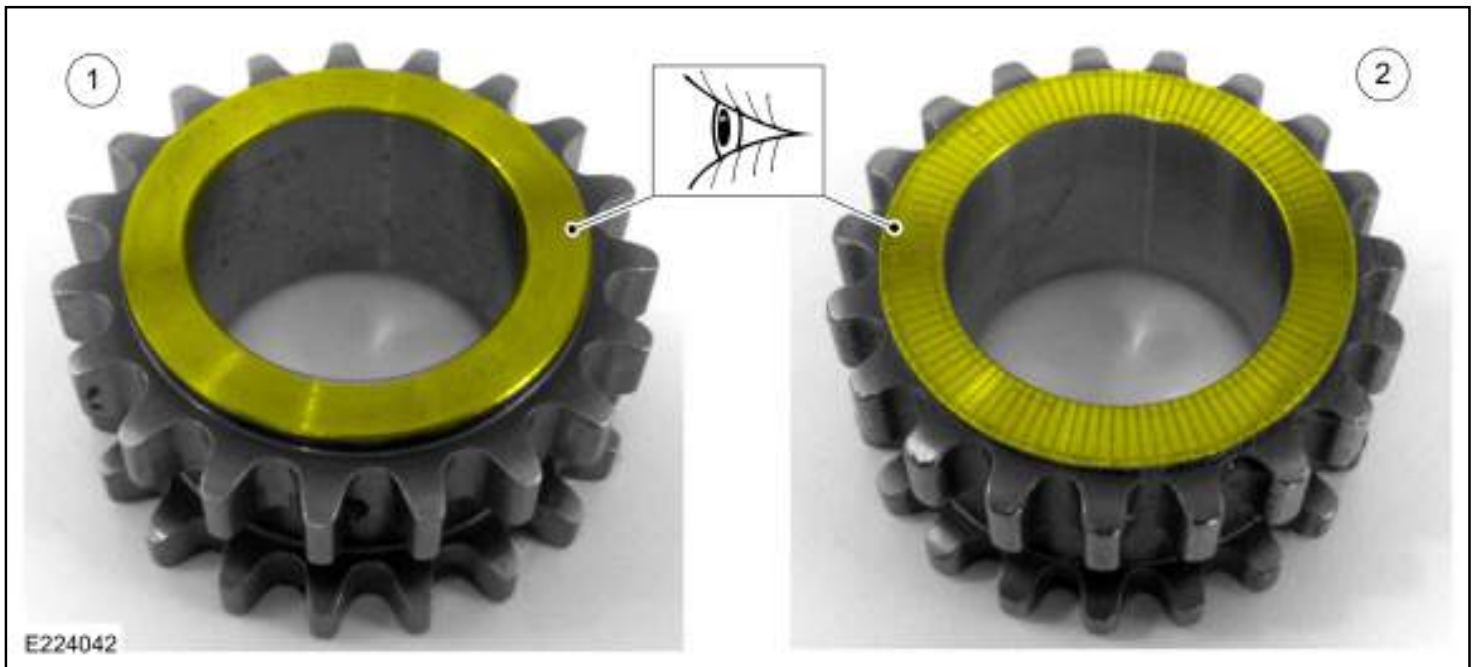

3. **NOTICE:** Make sure that a new friction washer is installed.

If equipped with flat faced sprocket.

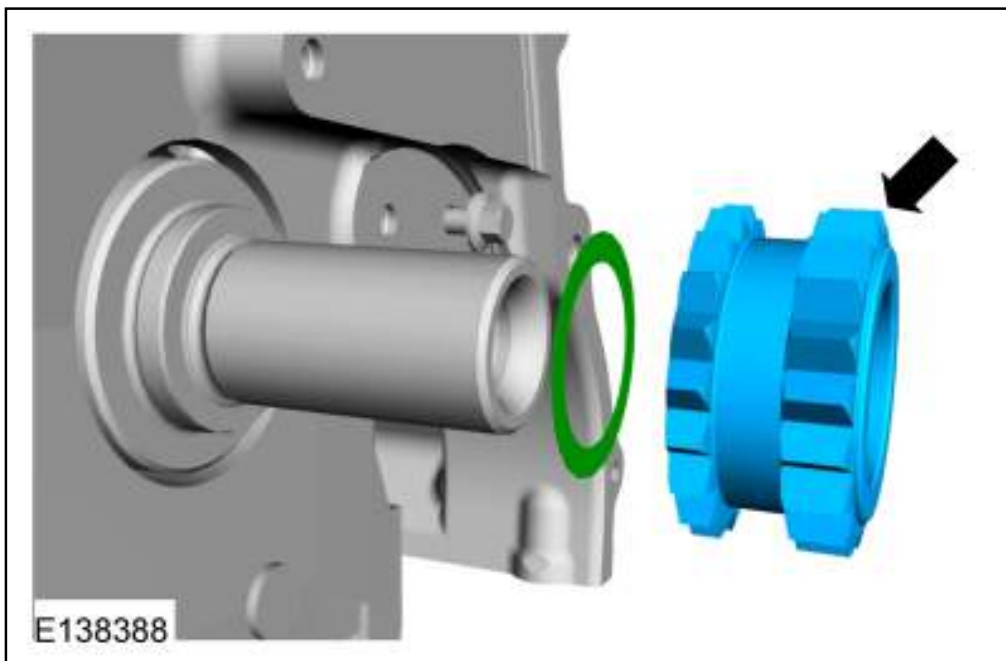

4. *Torque:*

Stage 1: 89 lb.in (10 Nm)

Stage 2: 177 lb.in (20 Nm)

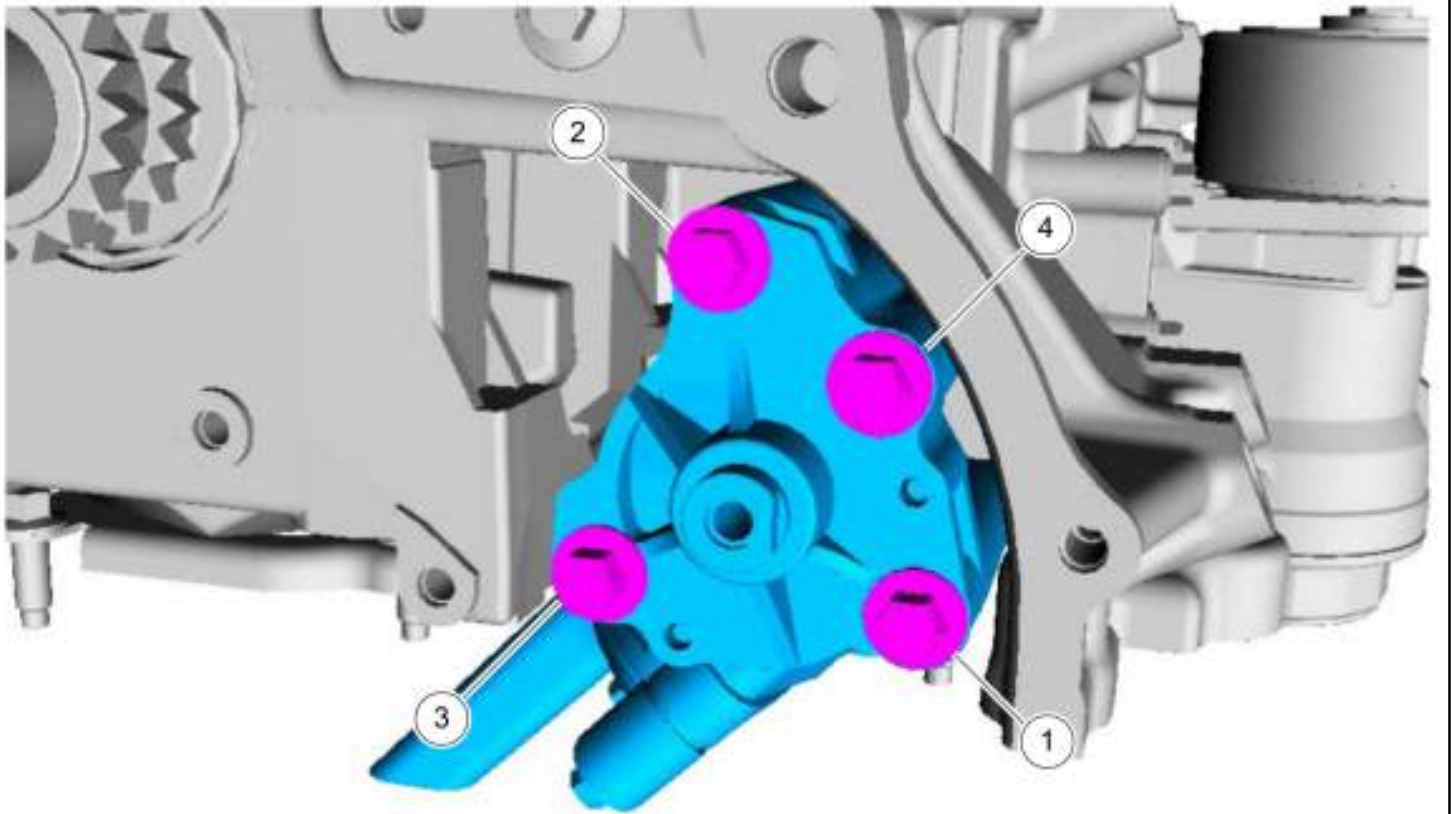

E66033



5. Torque: 18 lb.ft (25 Nm)

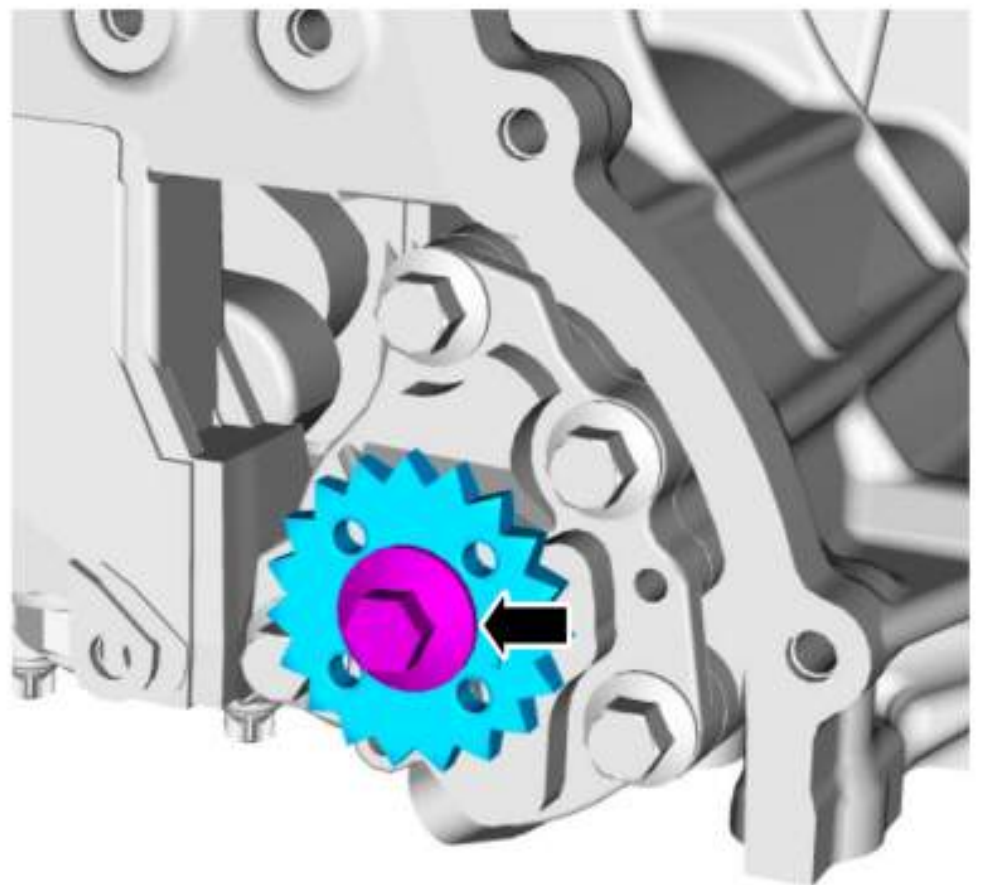

N0152219



6.  **WARNING:** The tensioner is under spring tension. Be careful when handling the tensioner. Failure to follow this instruction may result in personal injury.

*Torque:* 89 lb.in (10 Nm)

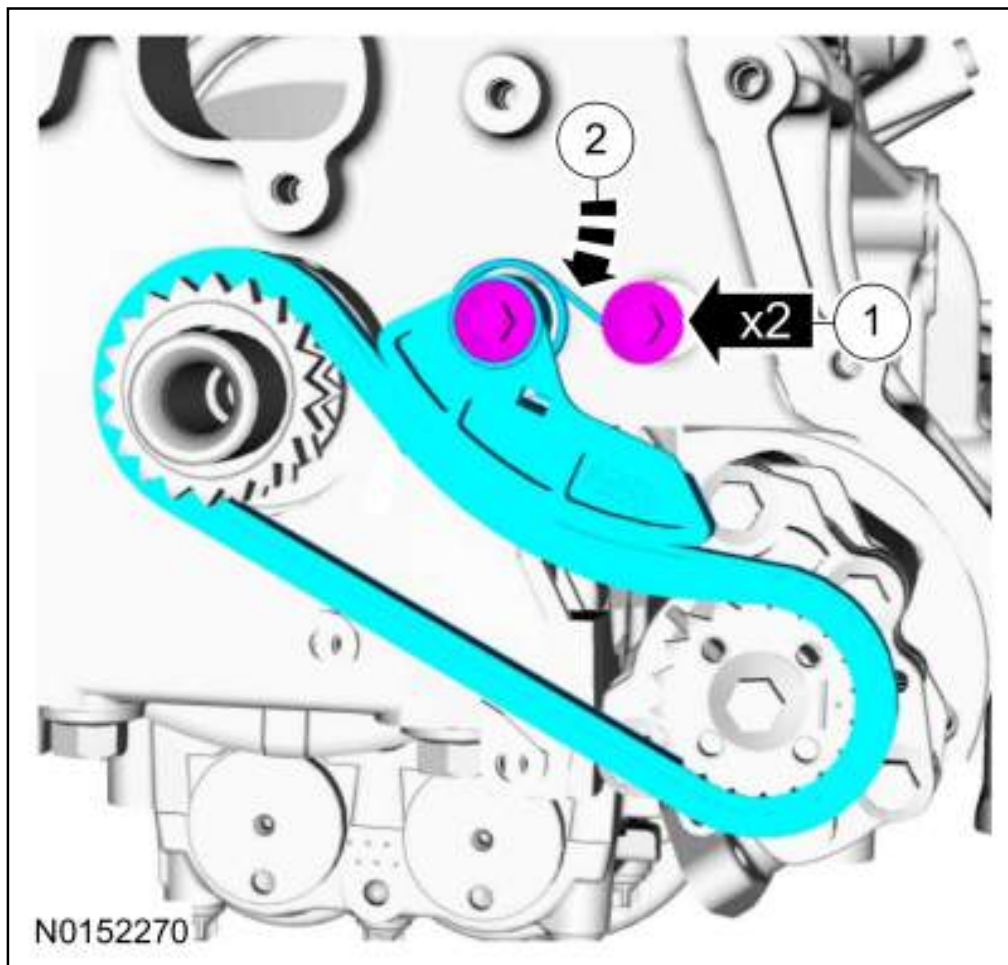

7. **NOTE:** Make sure that the component is clean, free of foreign material and lubricant.

Use the General Equipment: Plastic Scraper

*Material:* Motorcraft® Metal Surface Prep Wipes / ZC-31-B

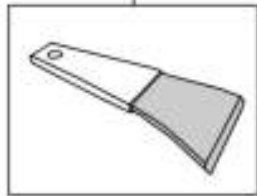

N0152516



8. **NOTE:** *Make sure that the component is clean, free of foreign material and lubricant.*

Use the General Equipment: Plastic Scraper

Material: Motorcraft® Metal Surface Prep Wipes / ZC-31-B

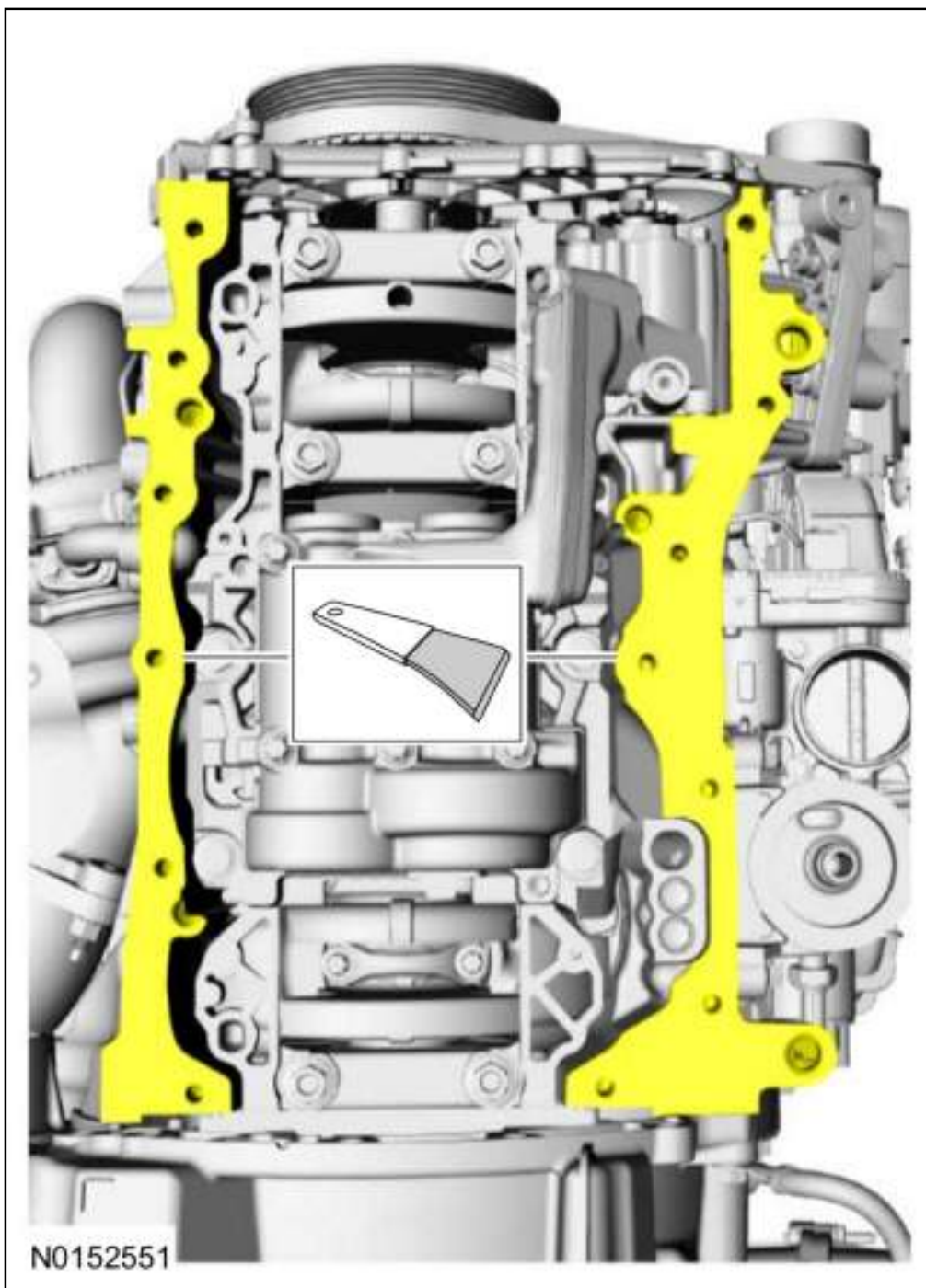

9. **NOTE:** Make sure that the mating faces are clean and free of foreign material.

**NOTE:** The component must be installed within 10 minutes of applying the sealant.

**Material:** Motorcraft® High Performance Engine RTV Silicone / TA-357 (WSE-M4G323-A6)

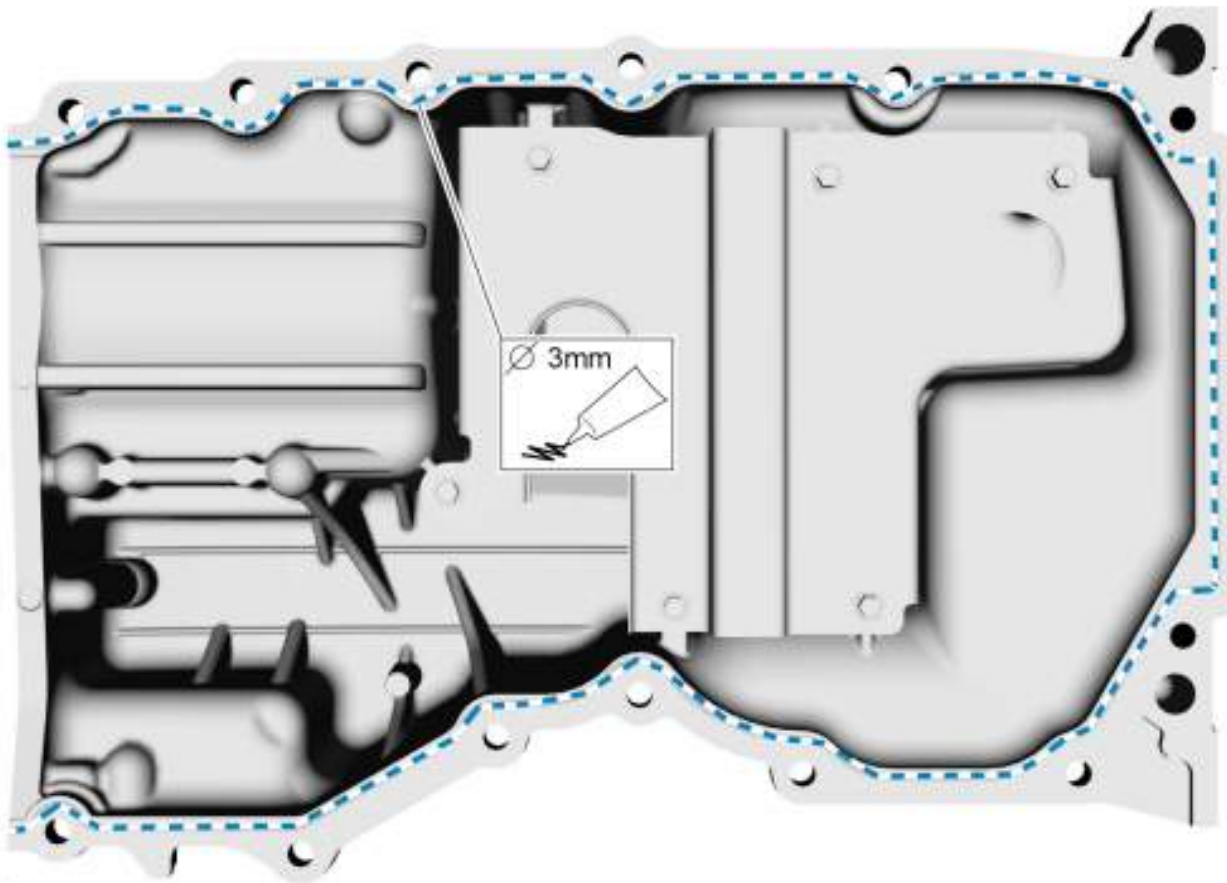

E137558

1. **NOTICE:** Make sure that the components are aligned.

**NOTE:** Only tighten the bolts finger tight at this stage.

Use the General Equipment: Round-Ended Steel Rule

2. **Torque:** 177 lb.in (20 Nm)



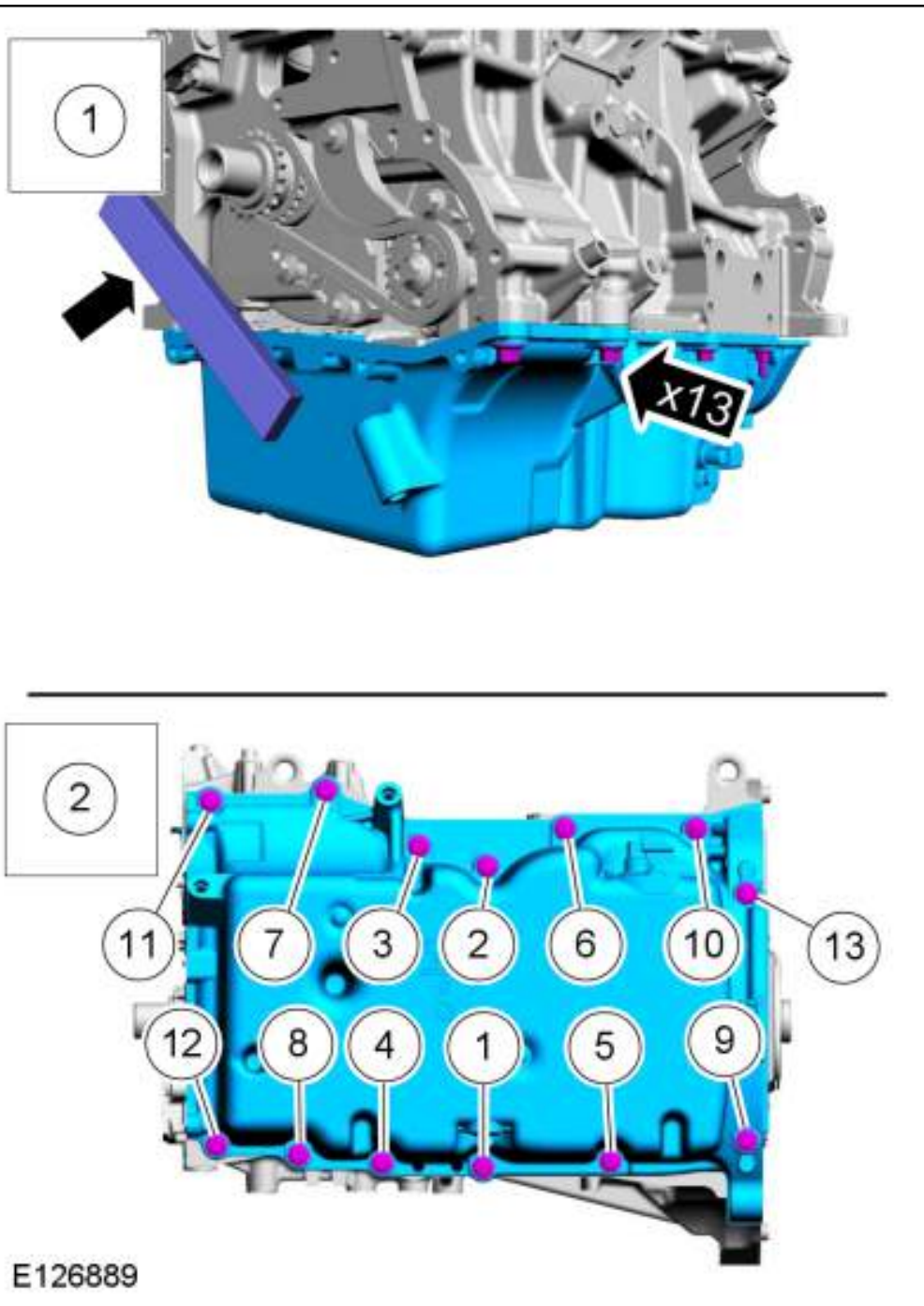

11. **NOTICE:** Only rotate the crankshaft clockwise.

Rotate the crankshaft until piston No. 1 is approximately 35° before top dead center (BTDC).

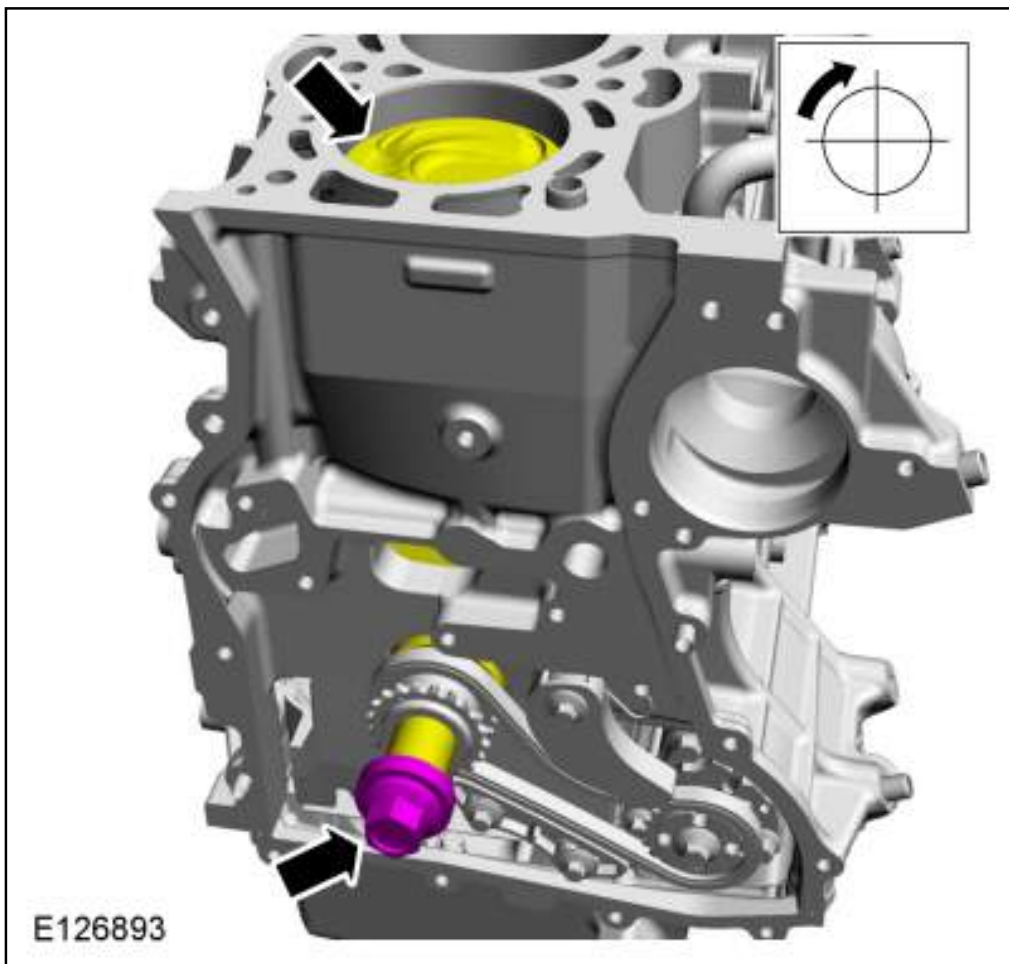

12. **NOTE:** *The component must be installed within 10 minutes of applying the sealant.*

Apply a drop of sealant at positions shown.

*Material:* Motorcraft® High Performance Engine RTV Silicone / TA-357 (WSE-M4G323-A6)

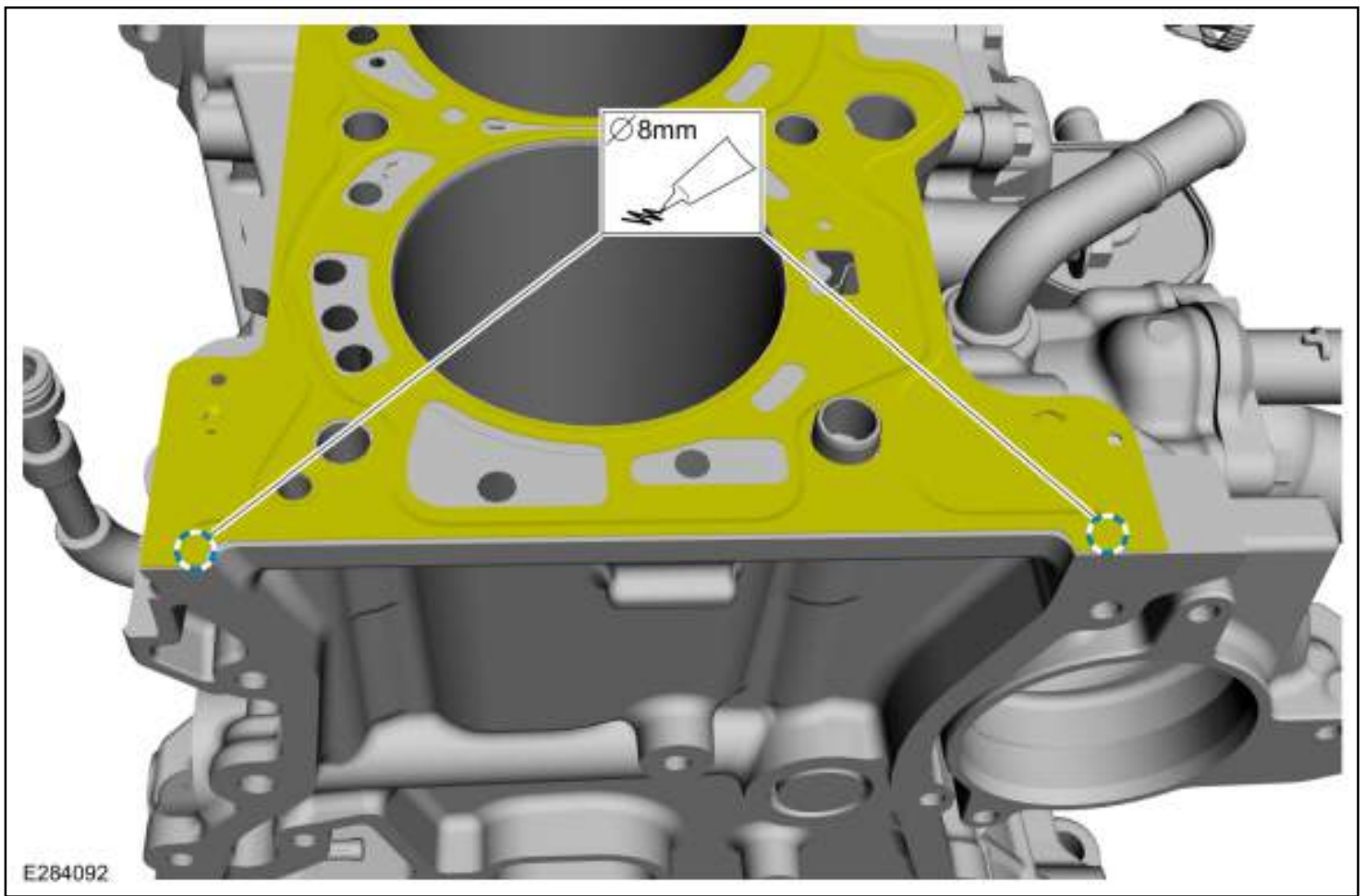

13. **NOTE:** Make sure that the mating faces are clean and free of foreign material.

*Torque:*

- Stage 1: 62 lb.in (7 Nm)
- Stage 2: 133 lb.in (15 Nm)
- Stage 3: 41 lb.ft (55 Nm)
- Stage 4: 90°
- Stage 5: 90°

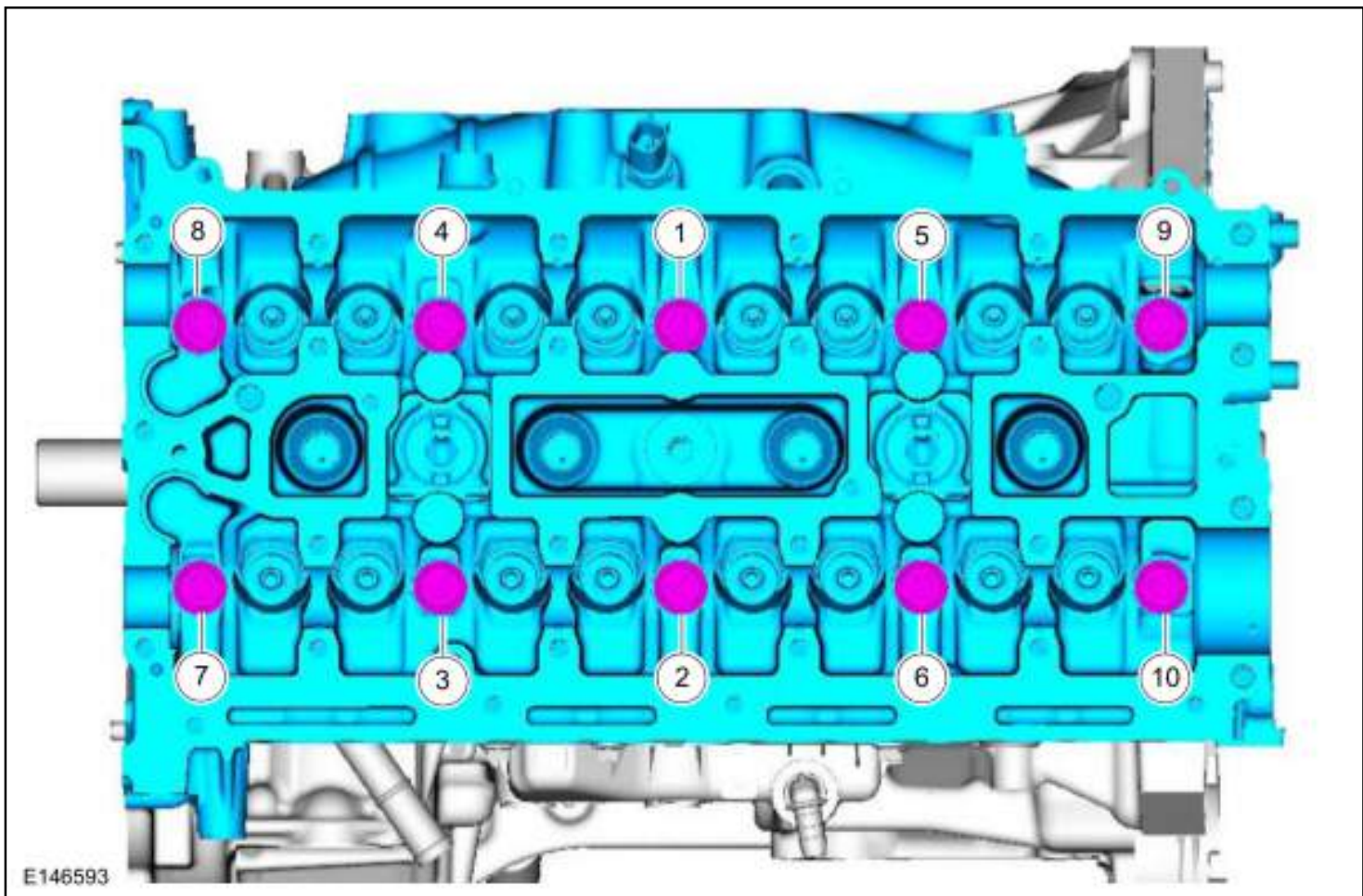

14. **NOTE:** Make sure that the components are installed to the position noted before removal.

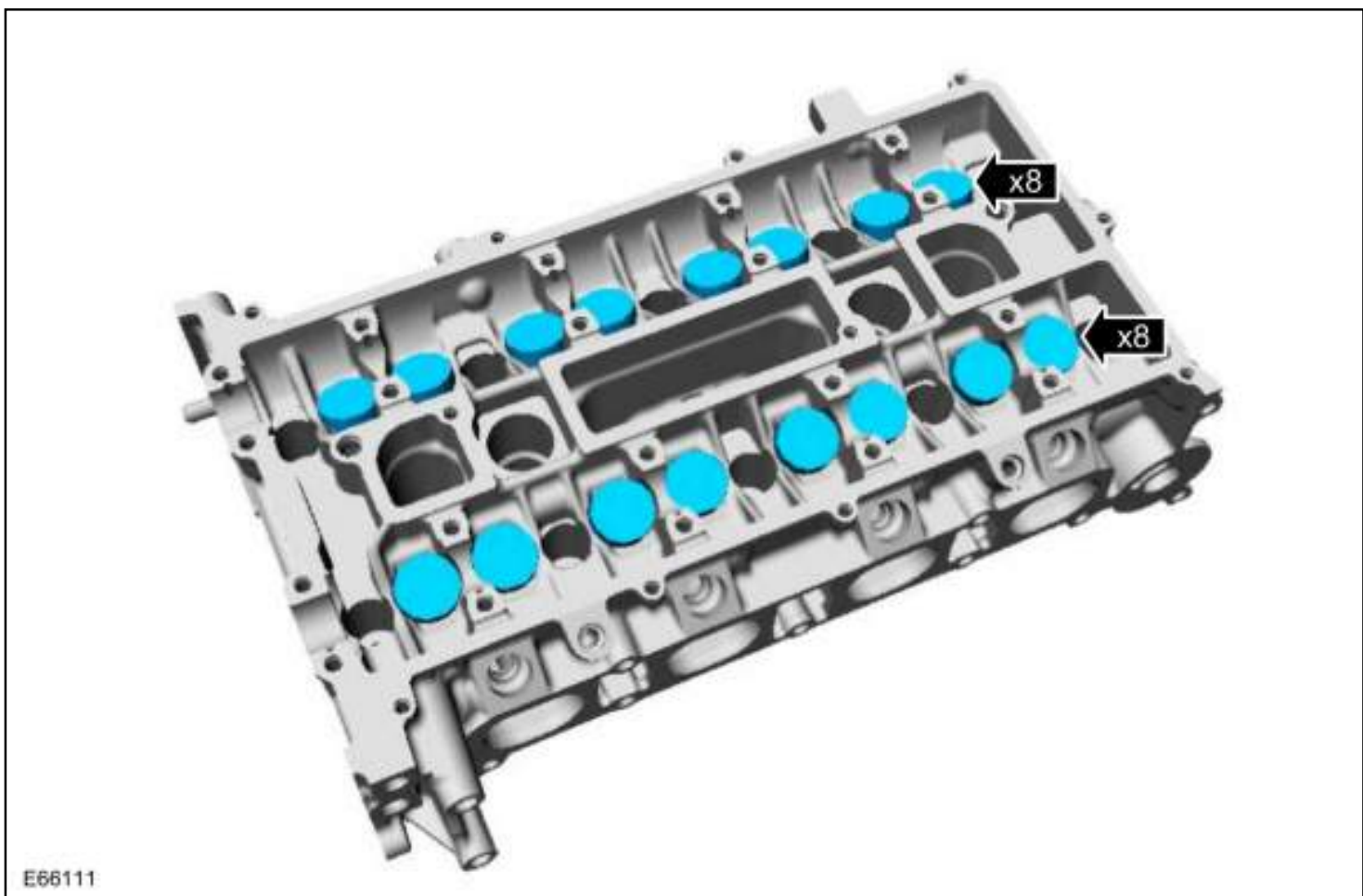

15. **NOTE:** Make sure that the mating faces are clean and free of foreign material.

**NOTE:** The component must be installed within 10 minutes of applying the sealant.

Material: Flange Sealant / CU7Z-19B508-A (WSS-M2G348-A11)

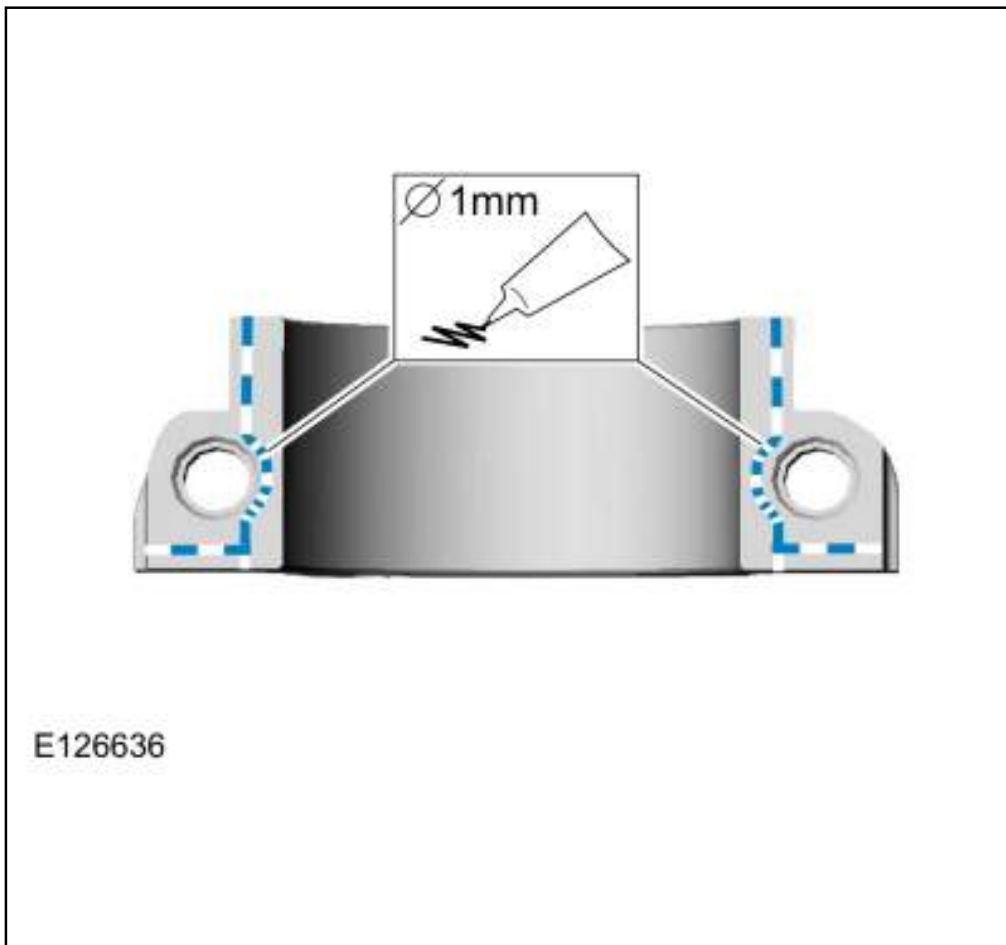

16. **NOTE:** Make sure that the components are installed to the position noted before removal.

Install the camshafts approximately at valve overlap position cylinder No. 4.

17. **NOTE:** Component(s) must be lubricated with clean engine oil.

Tighten each bolt 2 turns at a time.

Torque:

Stage 1: 62 lb.in (7 Nm)

Stage 2: 142 lb.in (16 Nm)

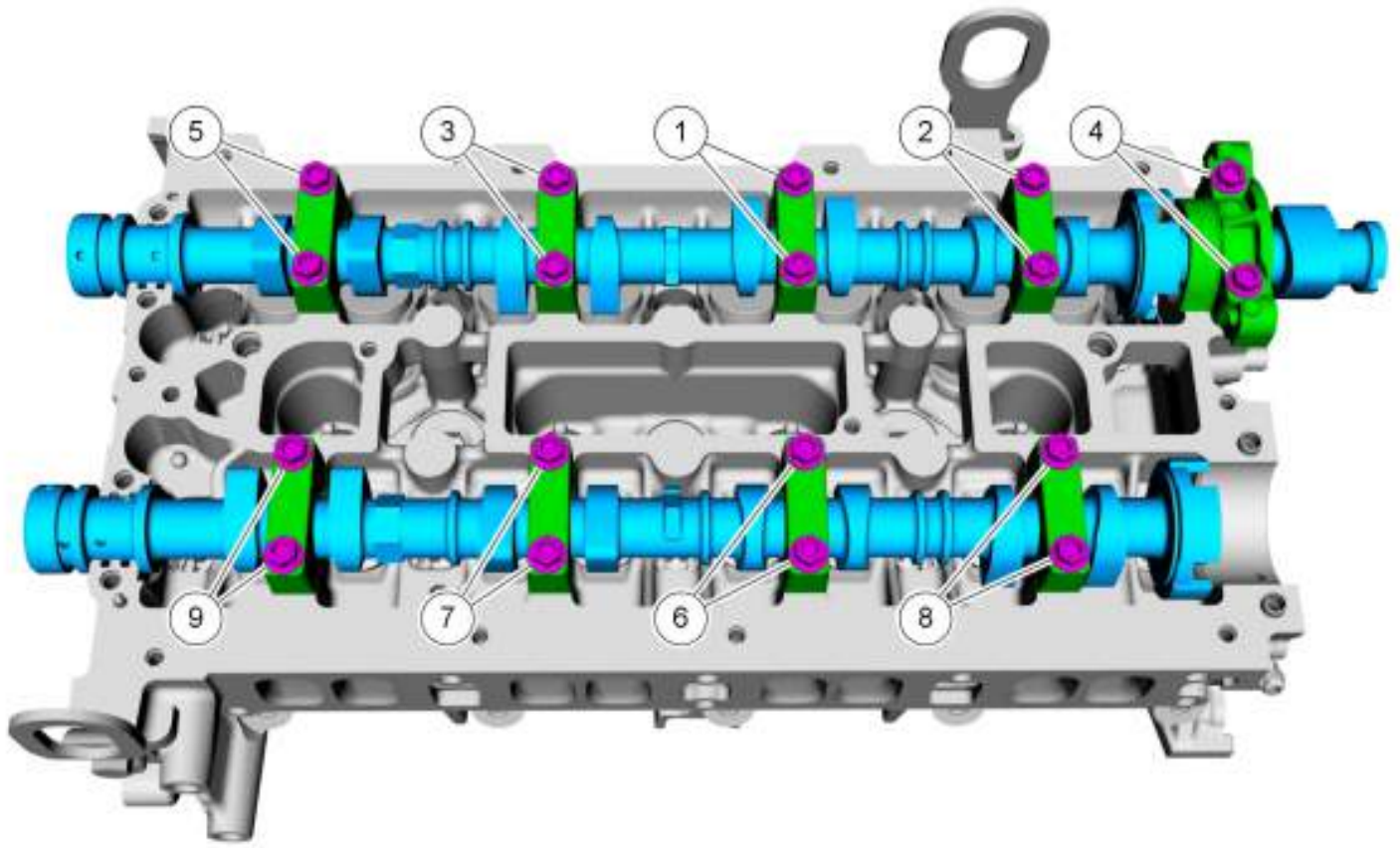

E138714

18. Install Special Service Tool: 303-1565 Alignment Tool, Camshaft.

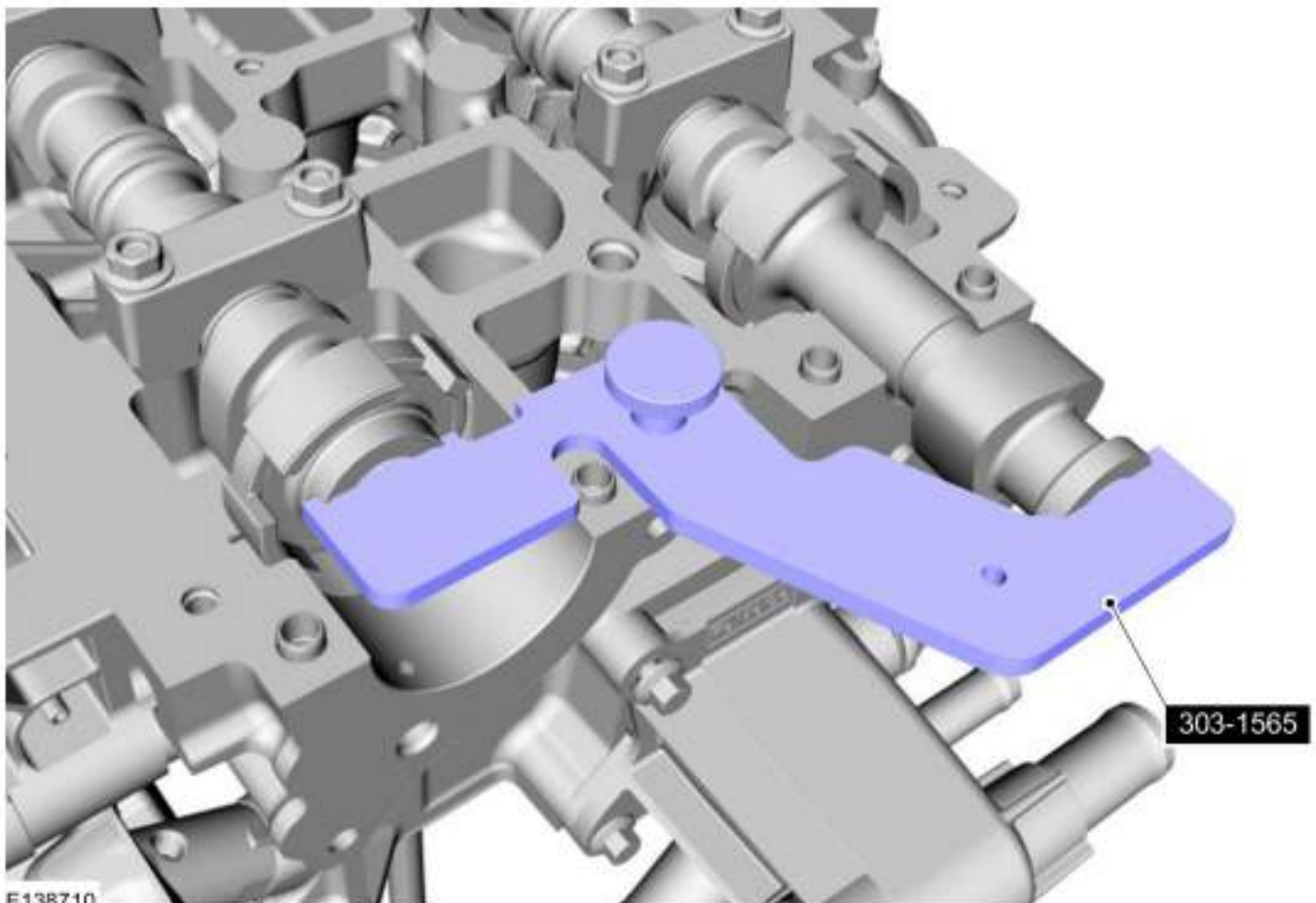

E138710



19. Tighten each bolt 2 turns at a time.

*Torque:*

Stage 1: 62 lb.in (7 Nm)

Stage 2: 142 lb.in (16 Nm)

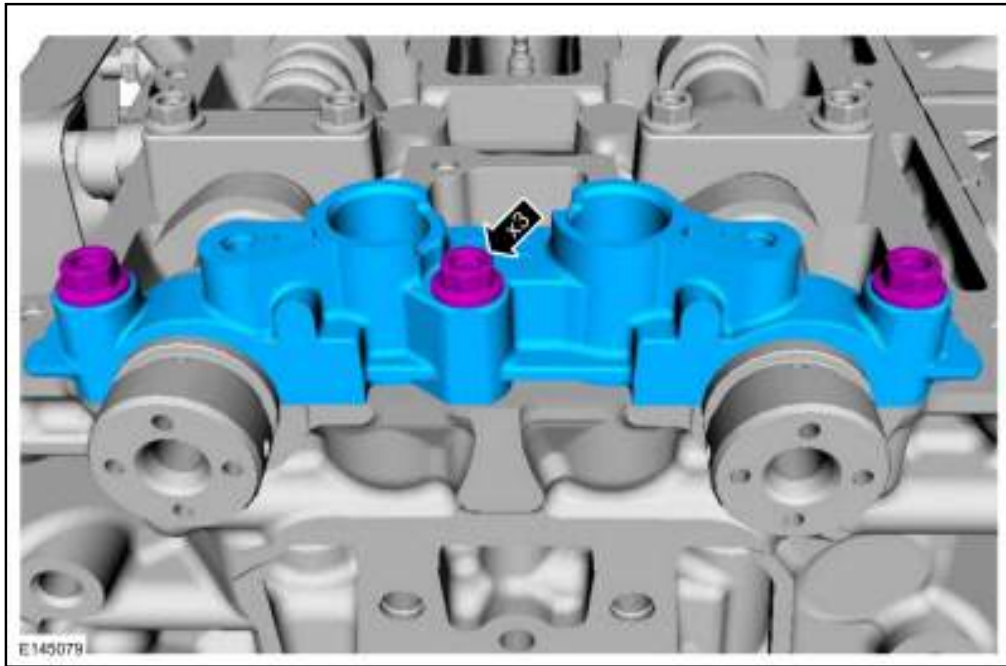

20. **NOTE:** Make sure that the components are installed to the position noted before removal.

*Torque:* 89 lb.in (10 Nm)

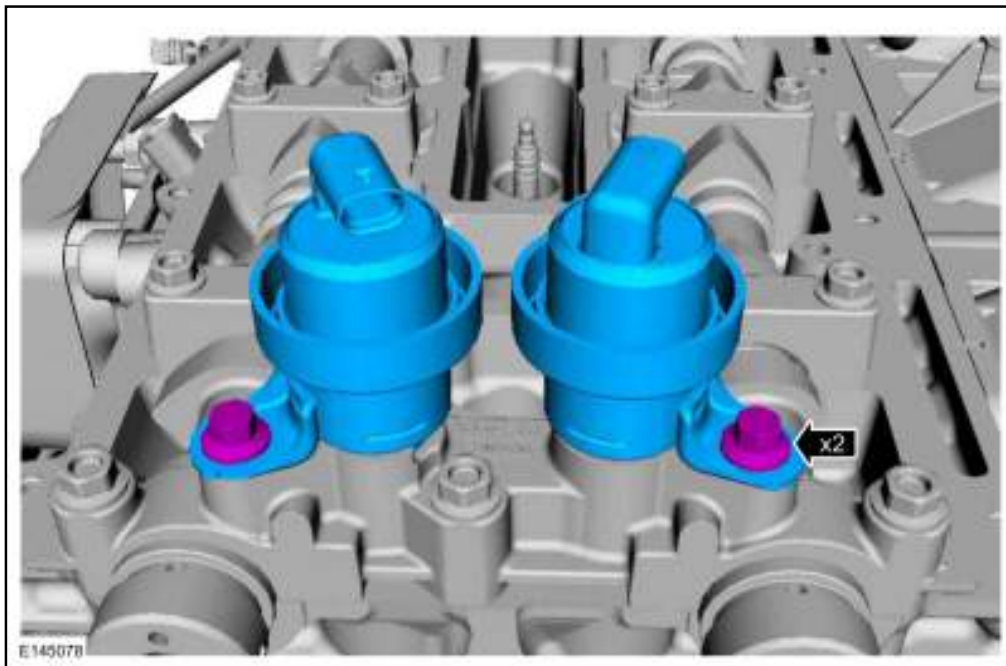

21. *Torque:* 89 lb.in (10 Nm)

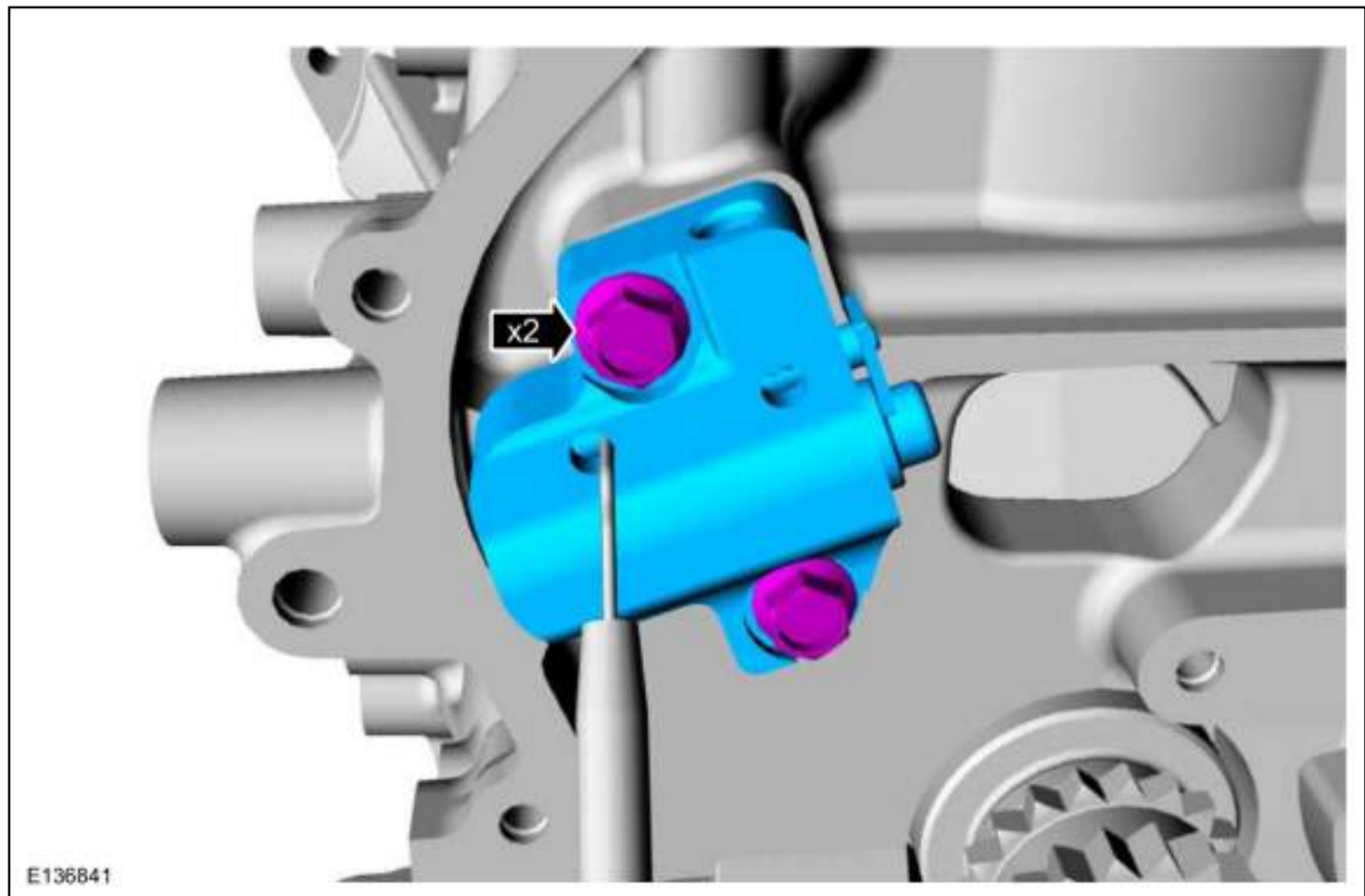

22. Torque: 89 lb.in (10 Nm)

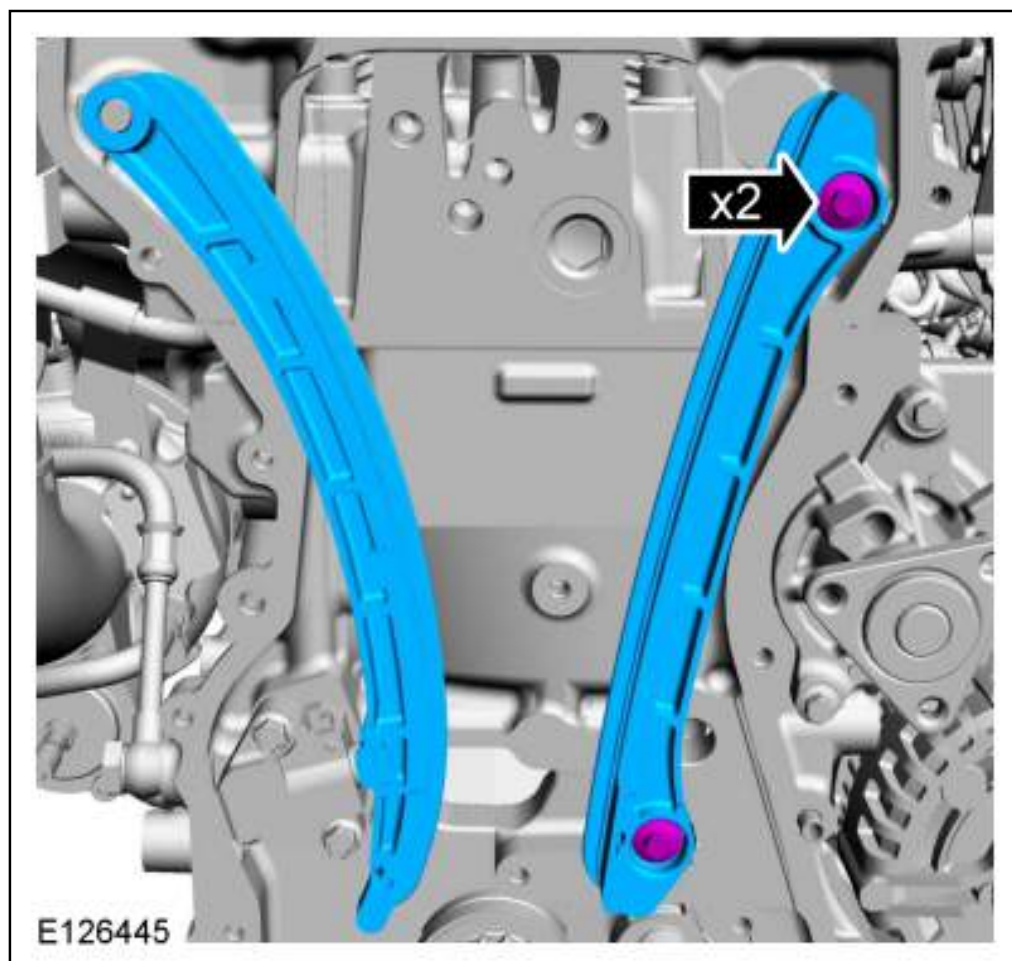

23. **NOTE:** Make sure that the components are installed to the position noted before removal.

**NOTE:** Only tighten the bolts finger tight at this stage.

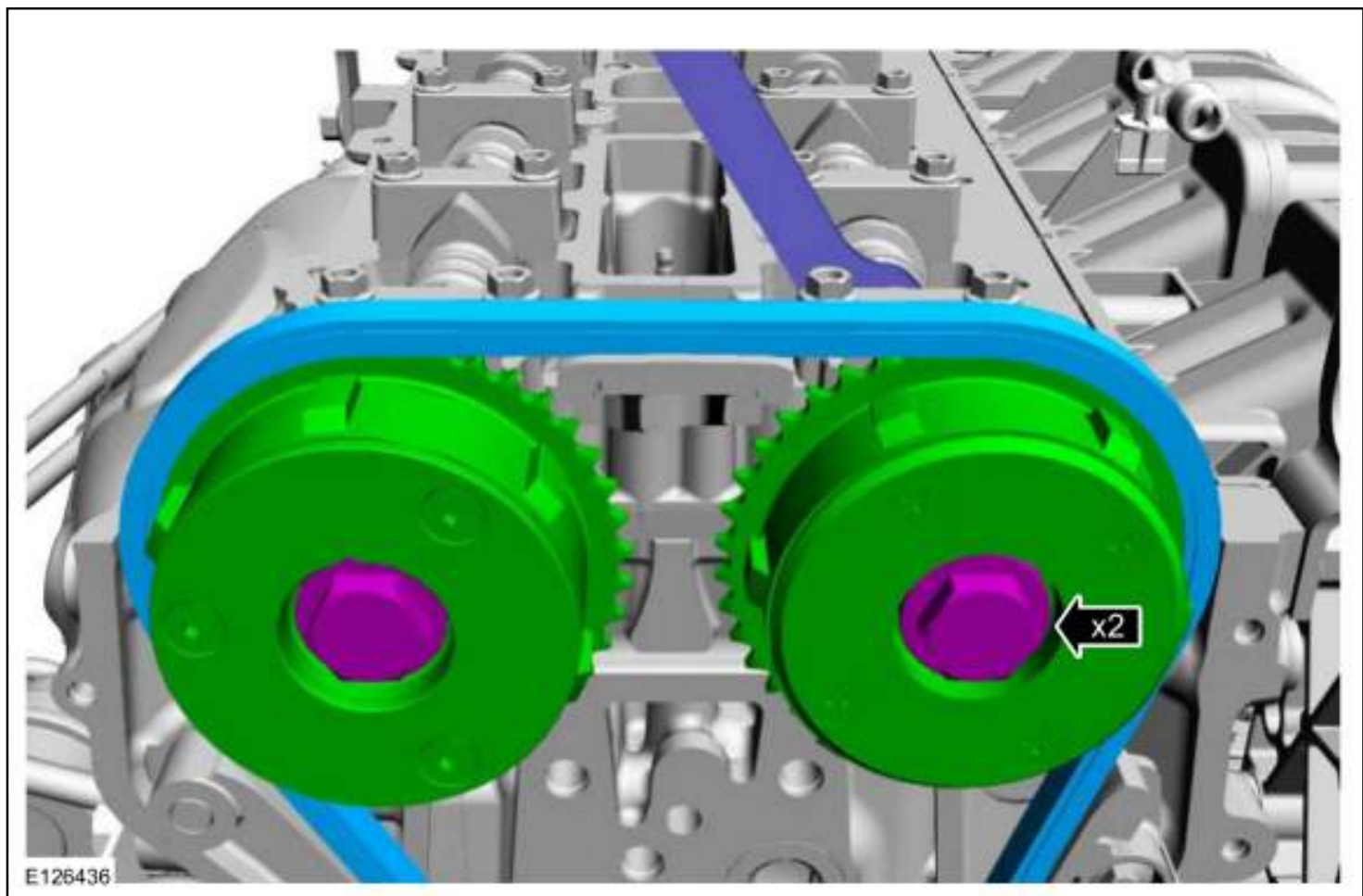

24. Remove Special Service Tool: 100-010 Remover, O-Ring Seal.

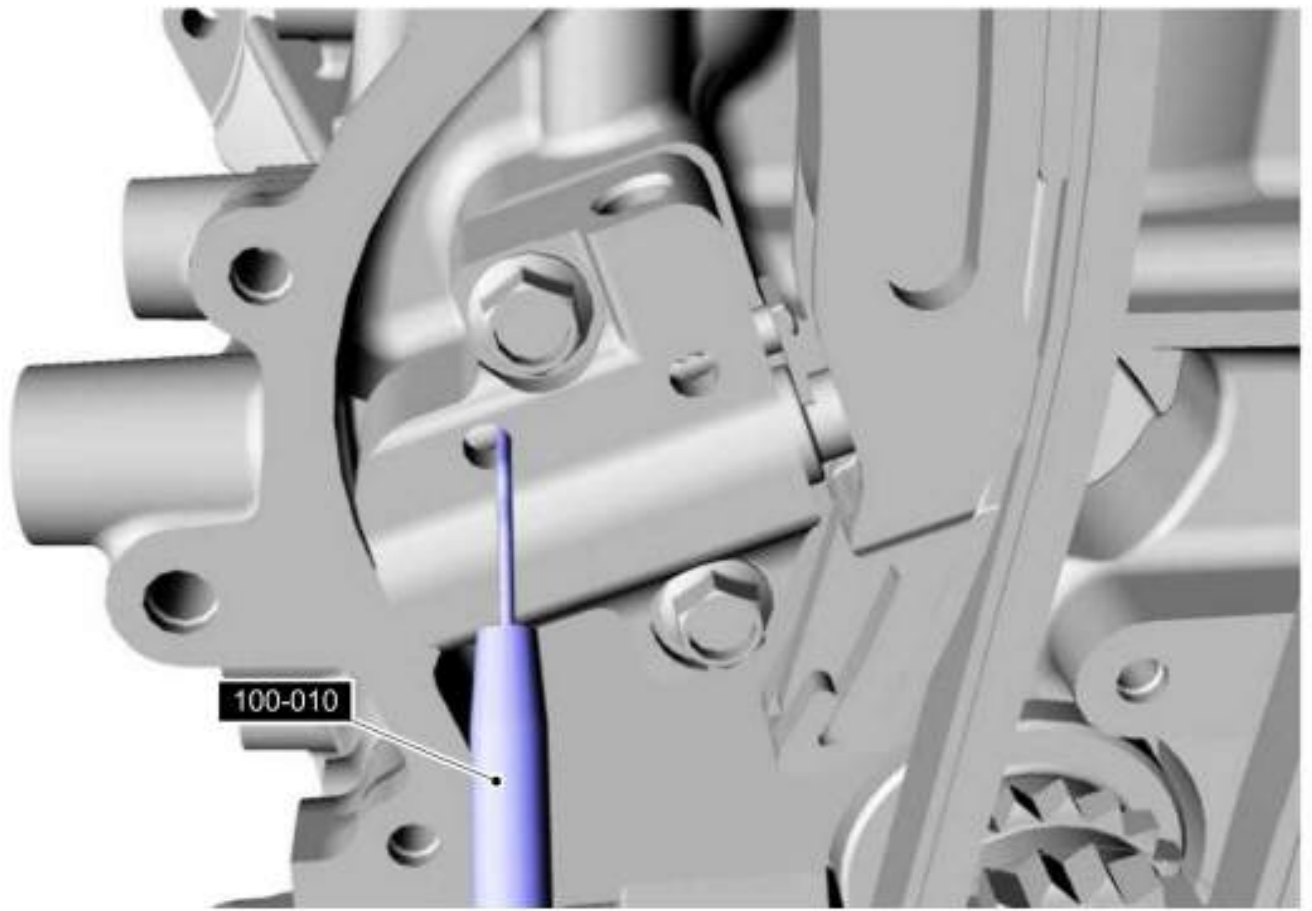

E136842

25. **NOTICE:** Use an open-ended wrench to prevent the component from turning.

*Torque:*

Stage 1: 30 lb.ft (40 Nm)

Stage 2: 60°



cardiagn.com

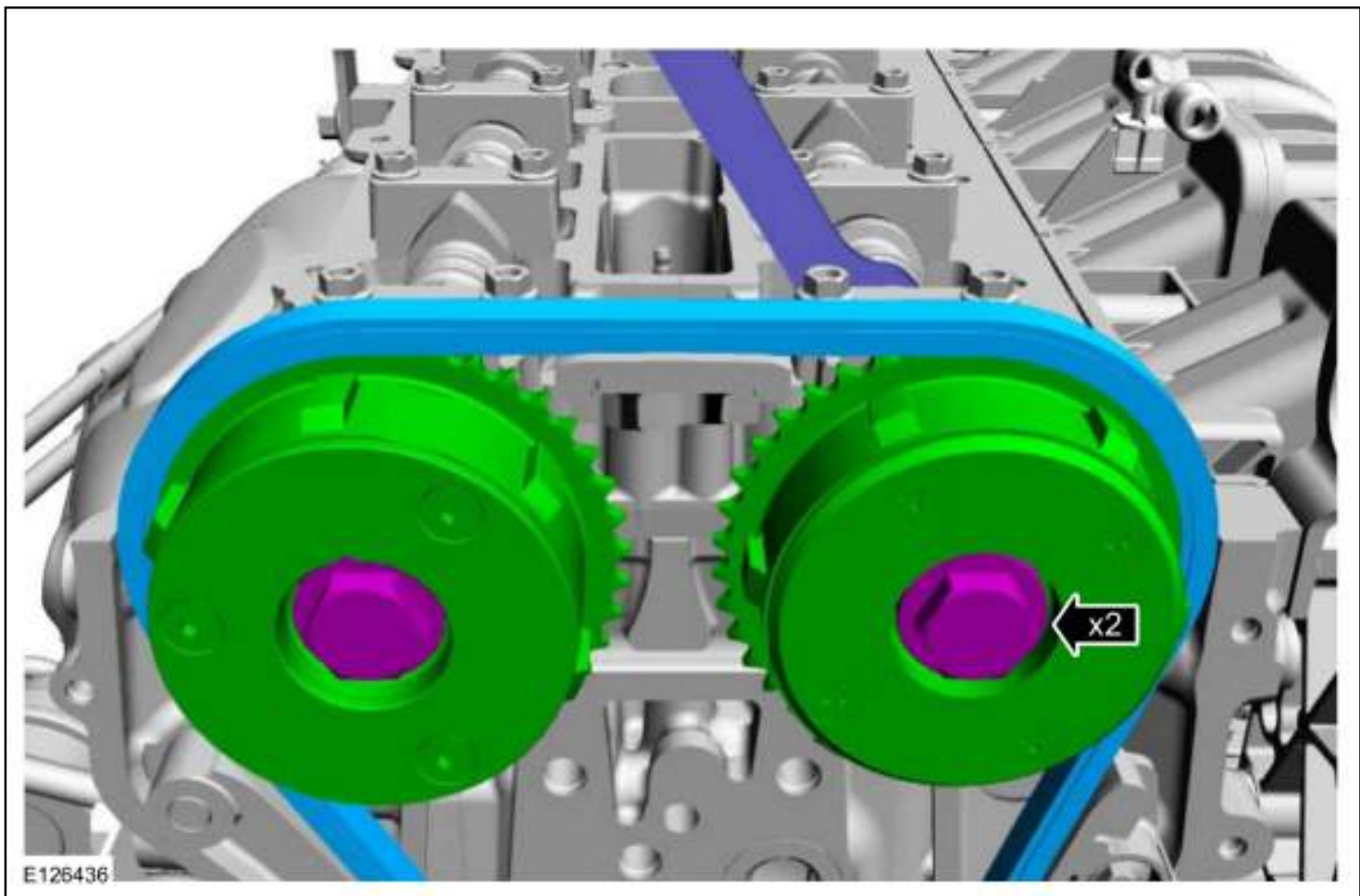

26. **NOTE:** *Make sure that the component is clean, free of foreign material and lubricant.*

Use the General Equipment: Plastic Scraper

Material: Motorcraft® Metal Surface Prep Wipes / ZC-31-B

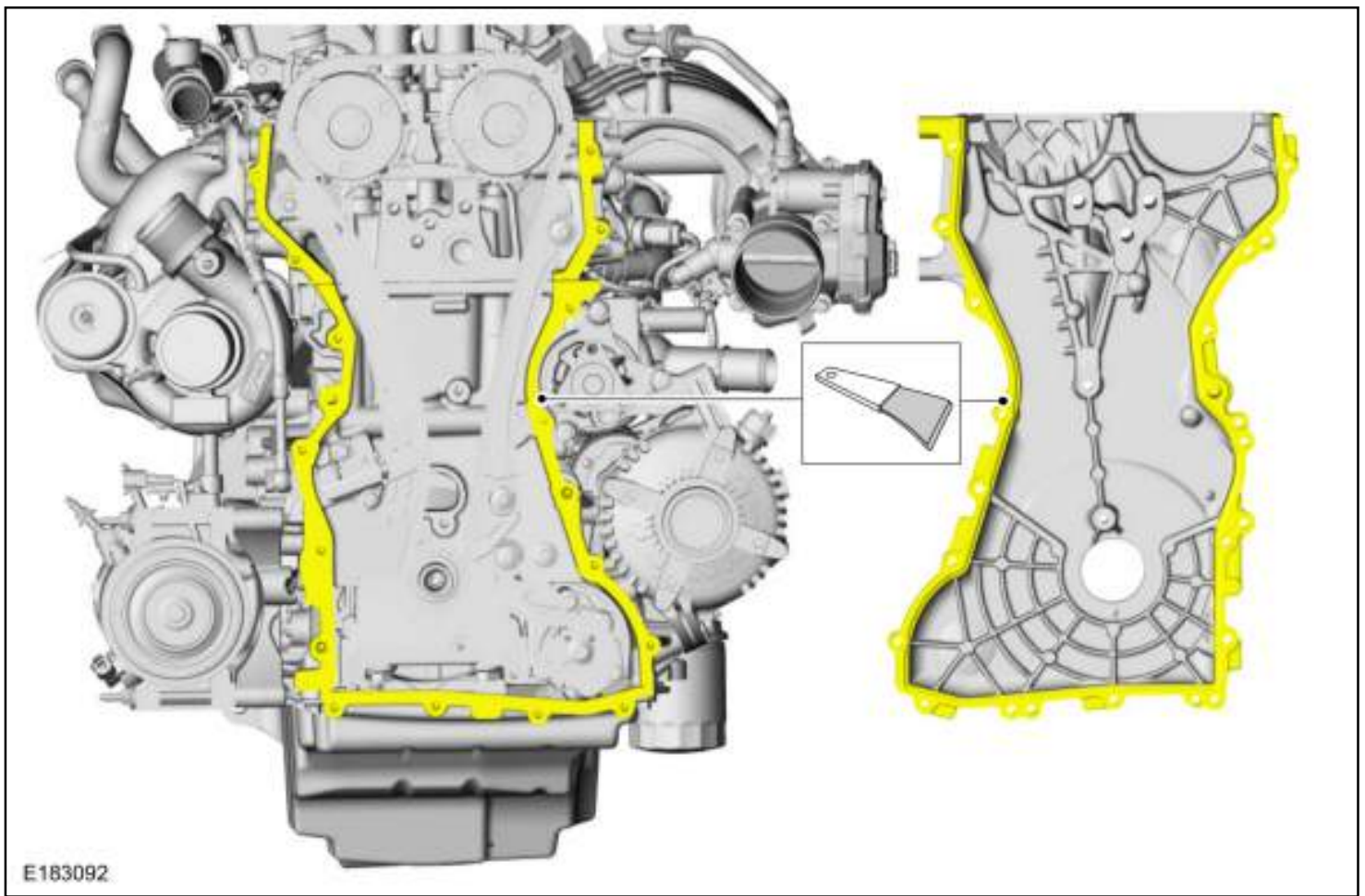

27. **NOTE:** Make sure that the mating faces are clean and free of foreign material.

**NOTE:** The component must be installed within 10 minutes of applying the sealant.

**Material:** Motorcraft® High Performance Engine RTV Silicone / TA-357 (WSE-M4G323-A6)

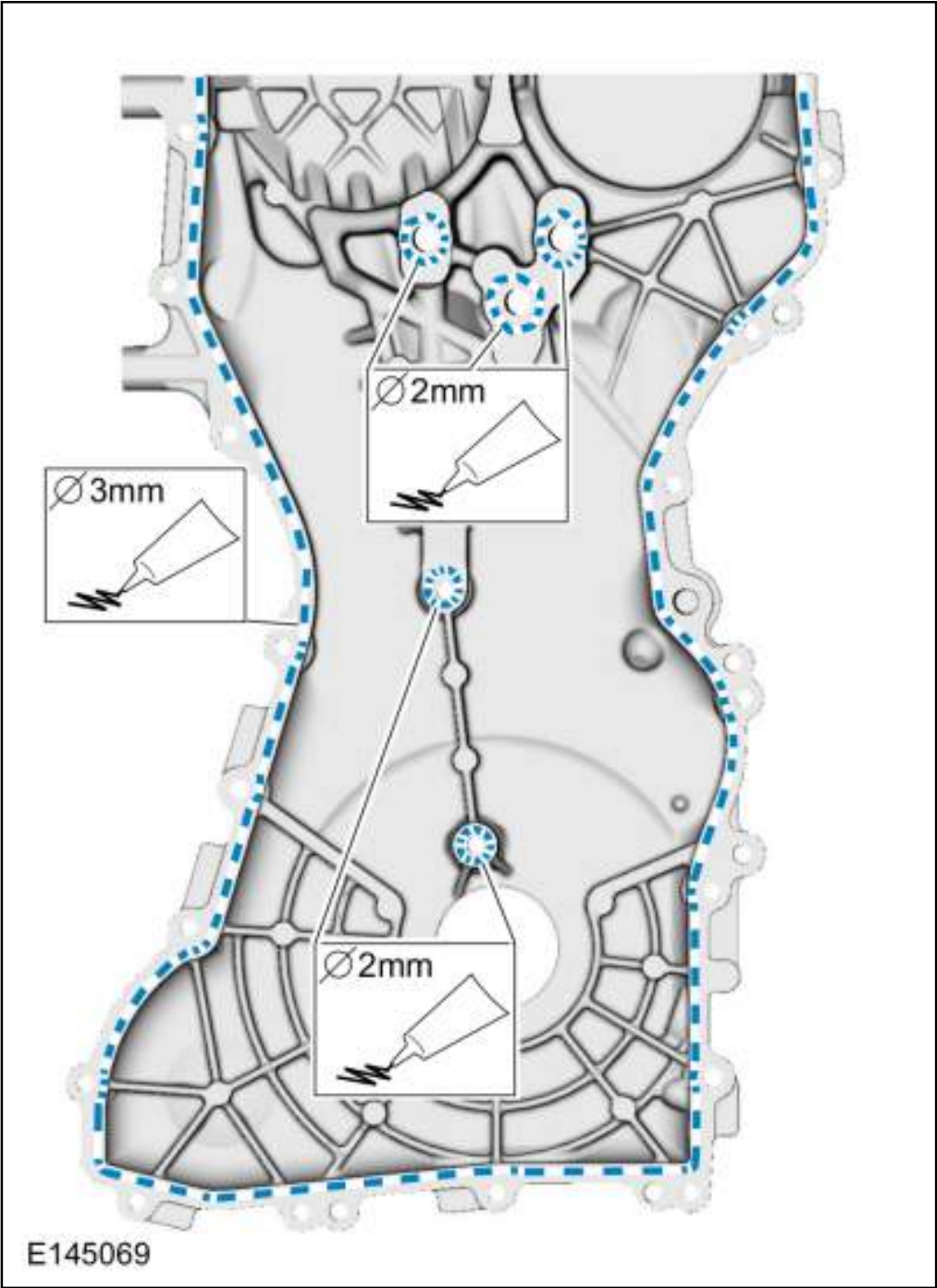

28. Material: Motorcraft® High Performance Engine RTV Silicone / TA-357 (WSE-M4G323-A6)

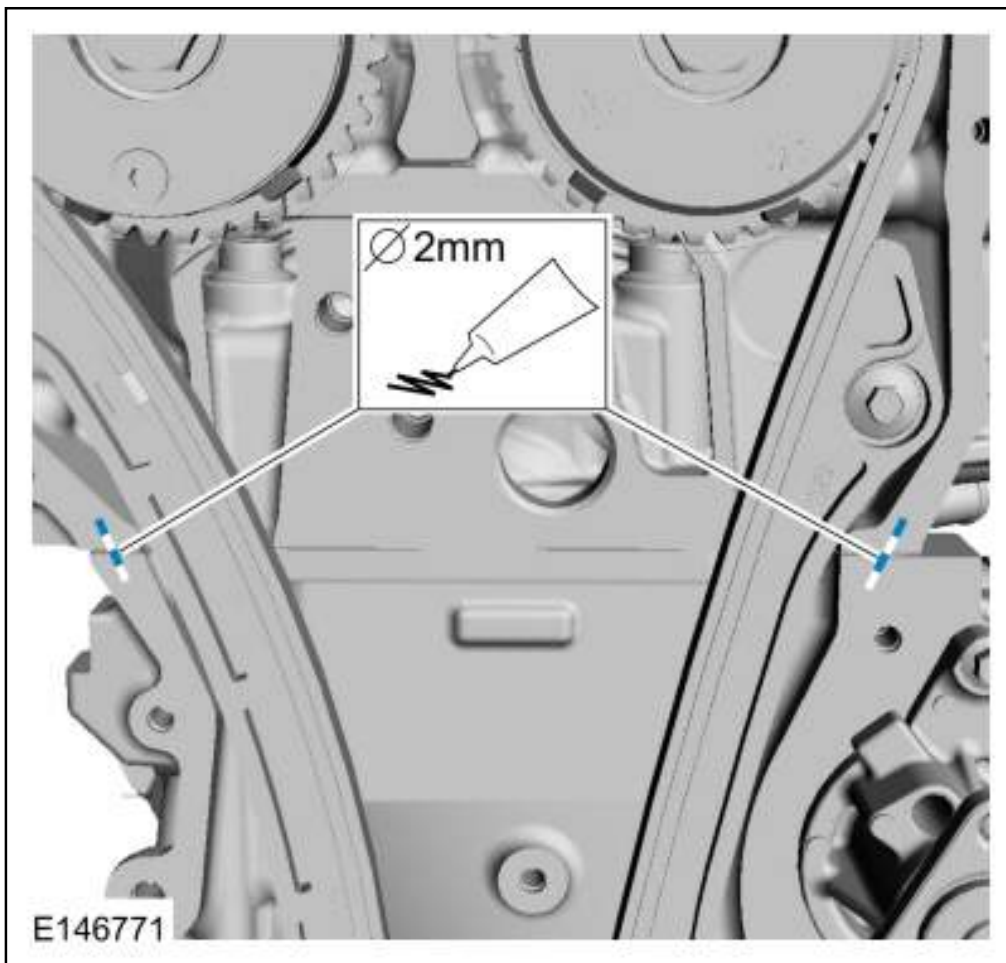

1. **NOTE:** *Install all the bolts finger tight before final tightening.*
2. *Torque:*  
1 - 19: 89 lb.in (10 Nm)
3. *Torque:*  
20 - 22: 35 lb.ft (48 Nm)

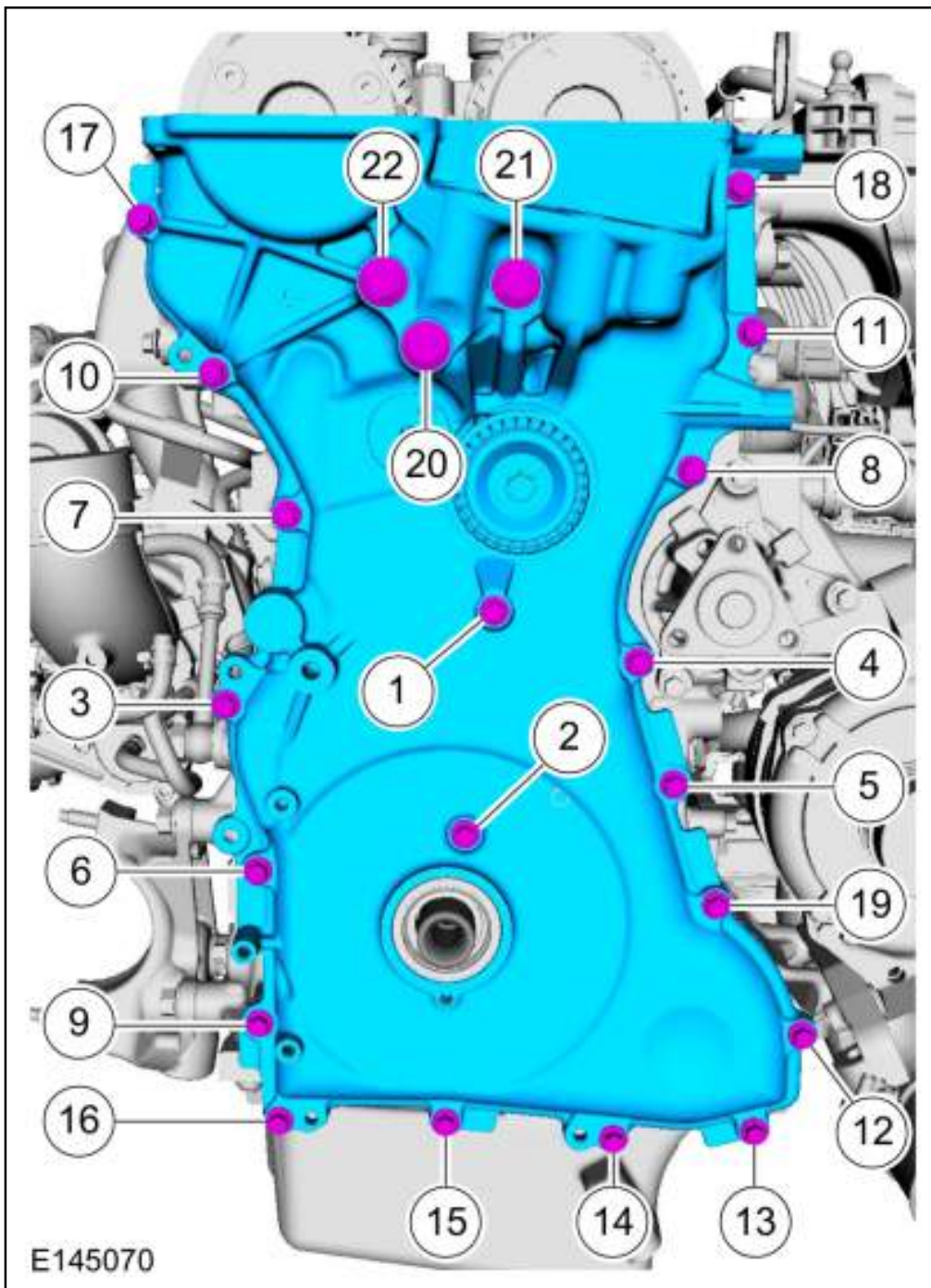

1. Flat faced sprocket – requires new friction washer.
2. Laser etched sprocket – does **NOT** require friction washer.

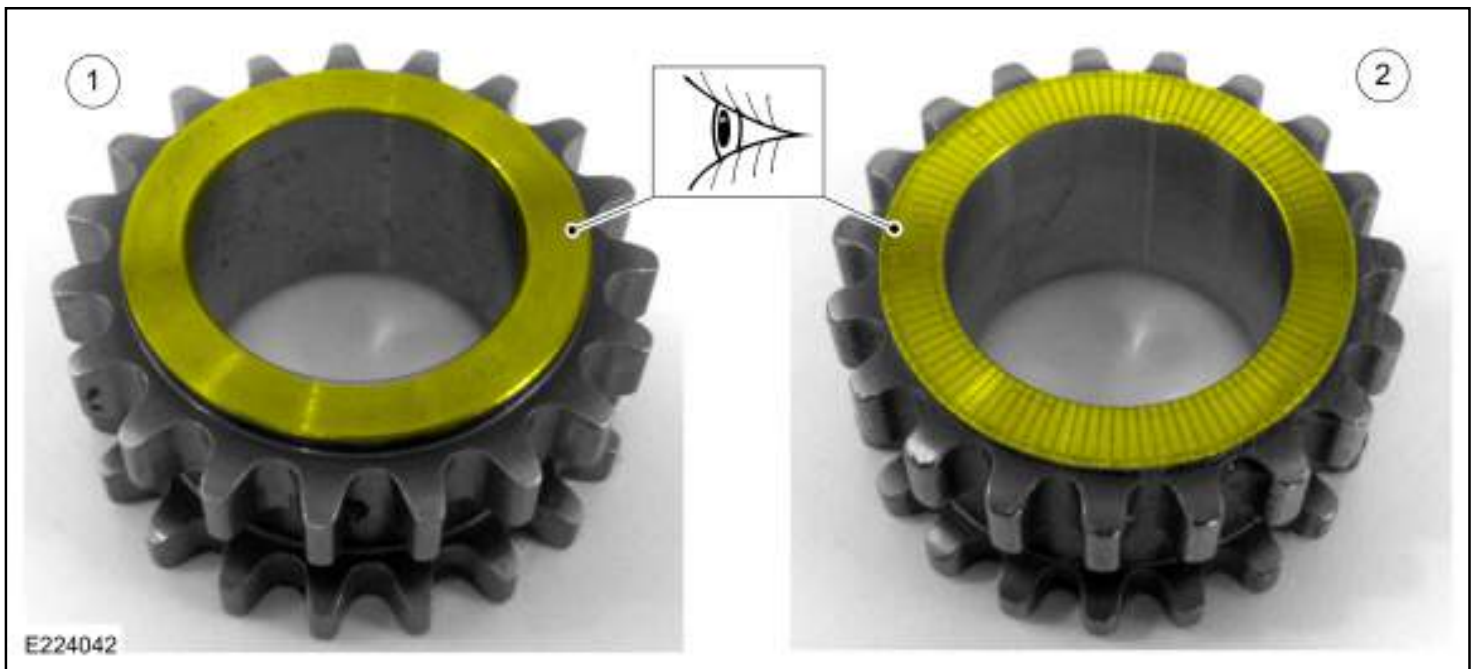

31. **NOTICE:** Make sure that a new friction washer is installed.

If equipped with flat faced sprocket.

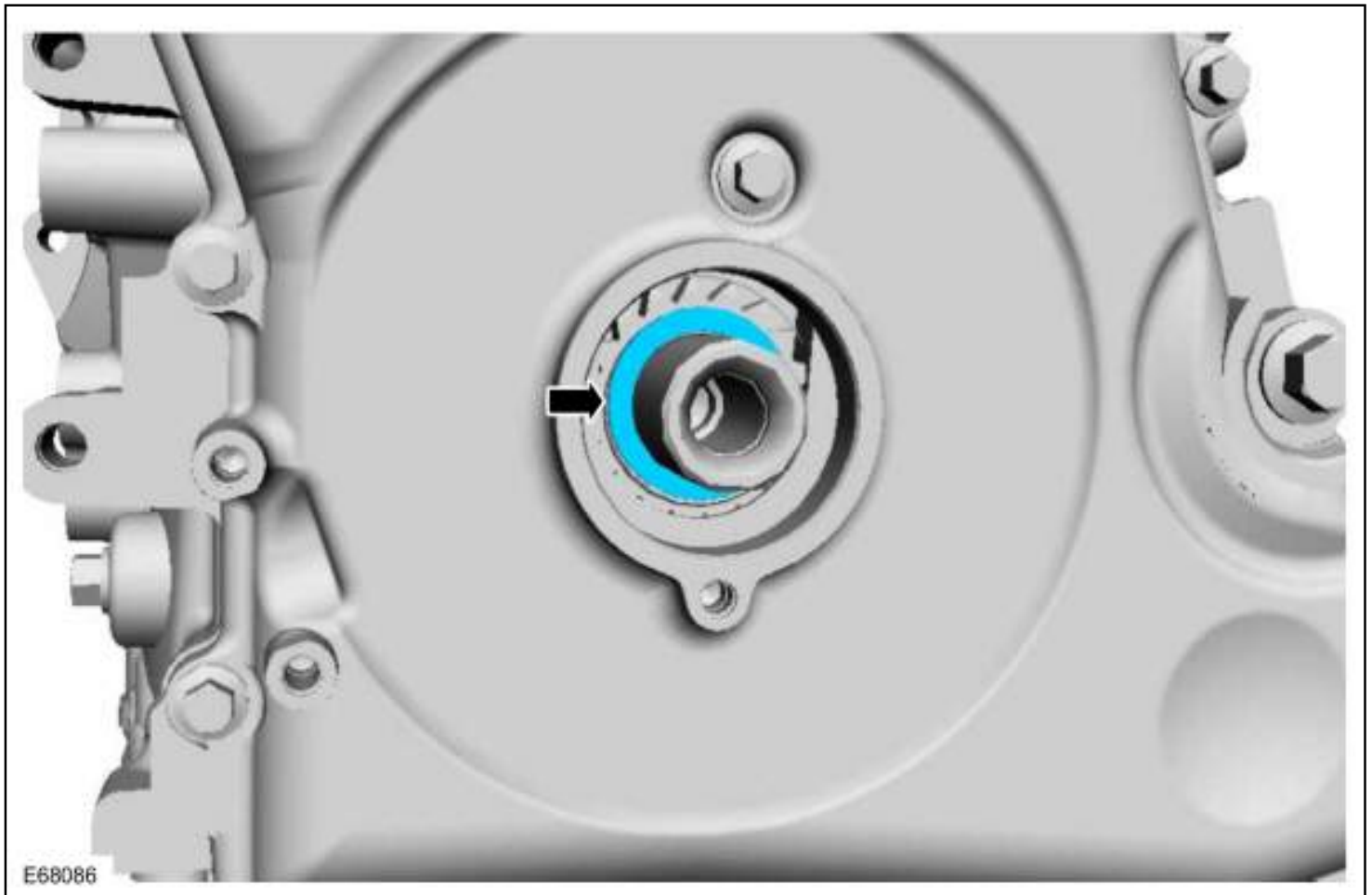

32. Use Special Service Tool: 303-509 Remover, Vibration Damper Hub.

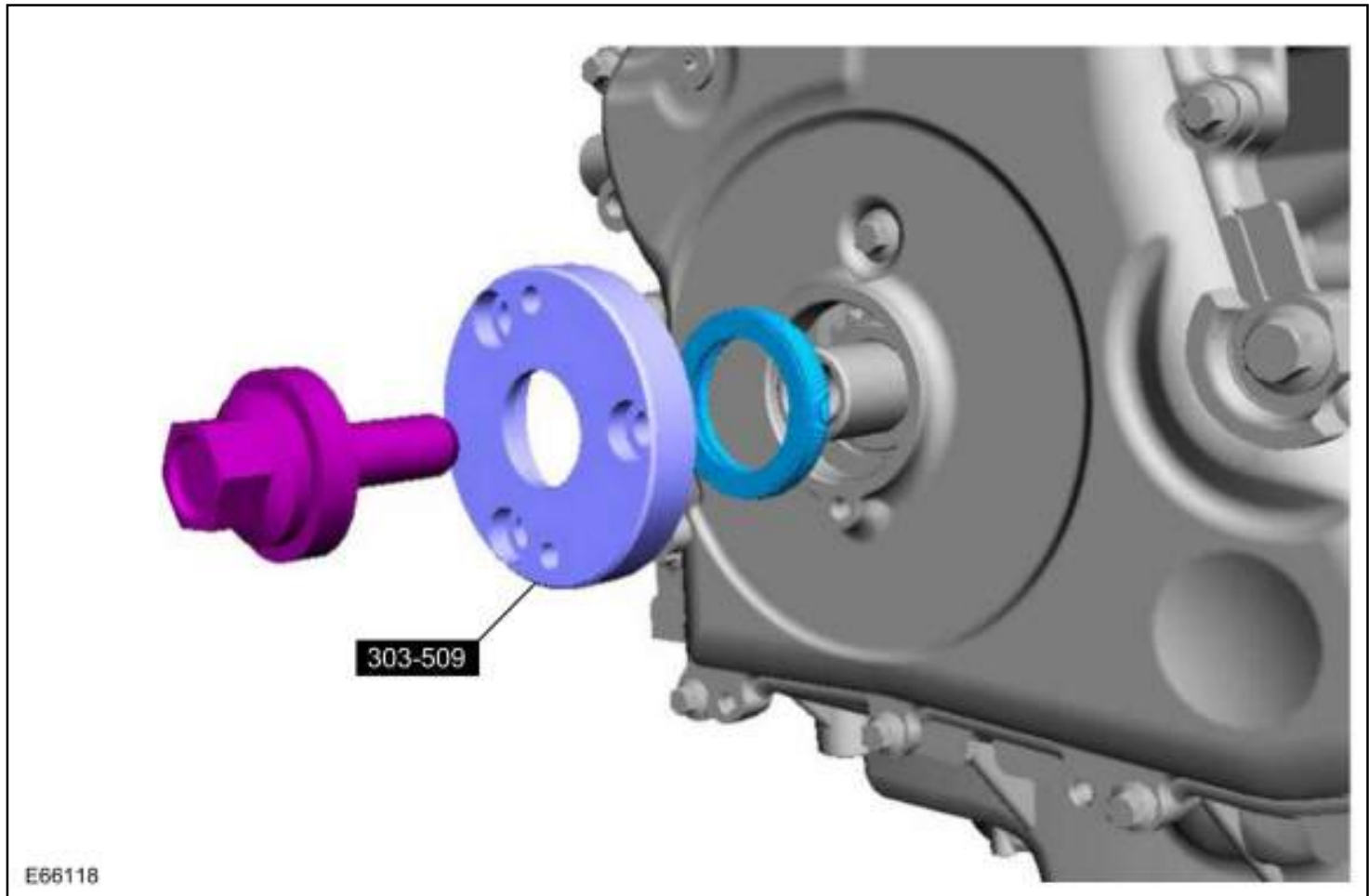

2. Install Special Service Tool: 303-748 Locking Tool, Crankshaft.

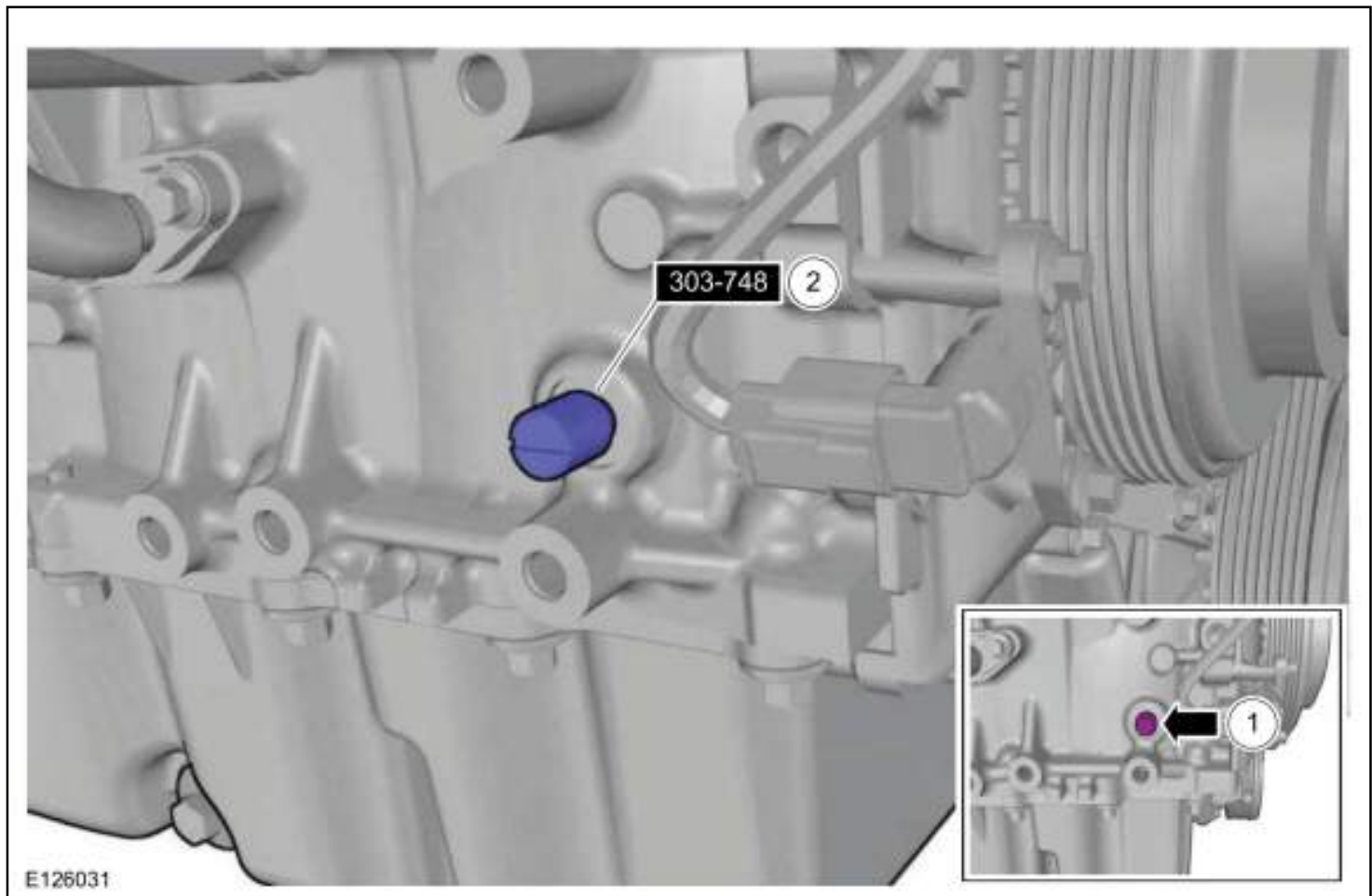

34. **NOTICE: Only rotate the crankshaft clockwise.**

Rotate the crankshaft slowly until the crankshaft stops.

Use Special Service Tool: 303-748 Locking Tool, Crankshaft.

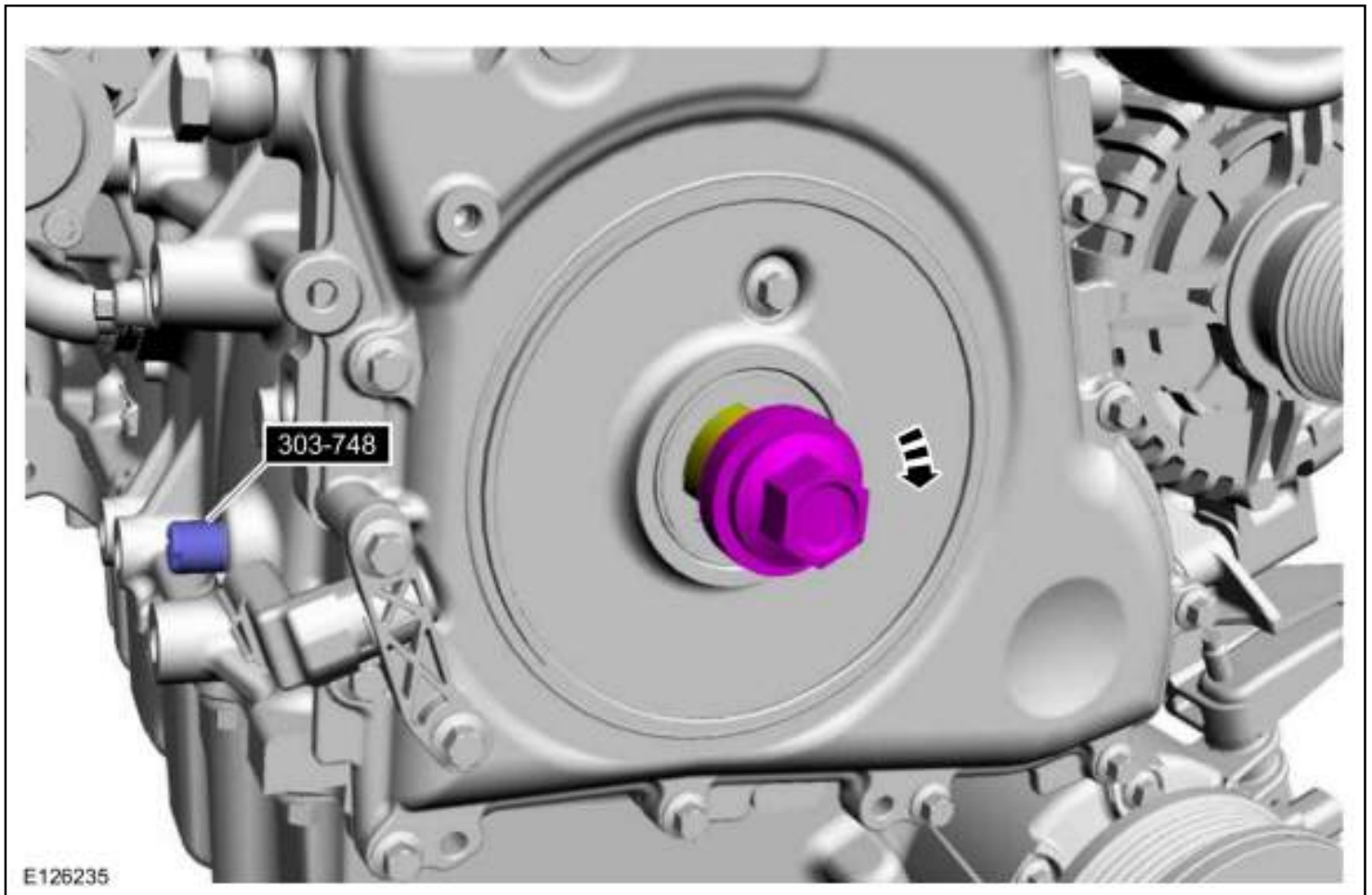

35.

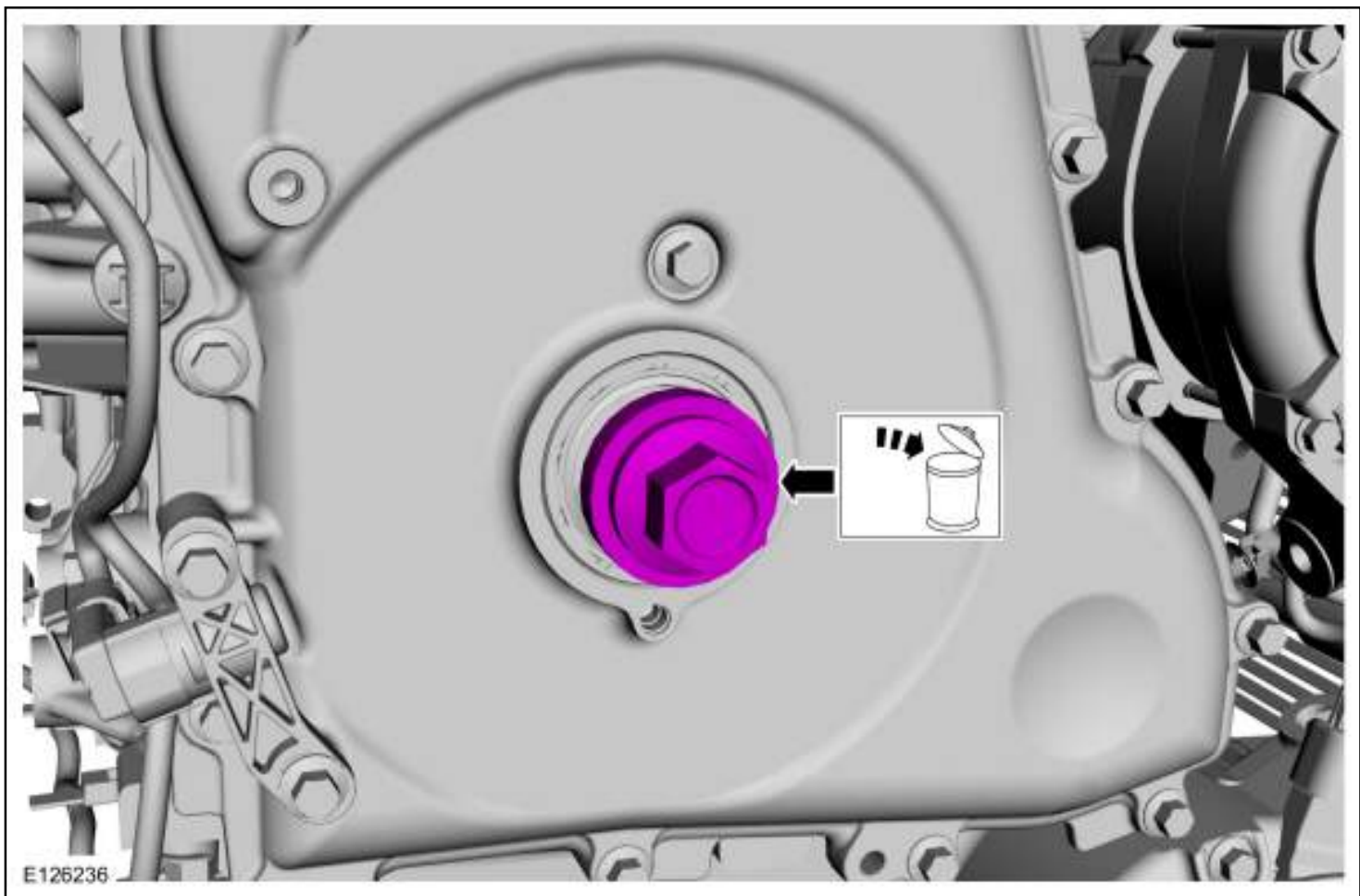

2. **NOTE:** *Only tighten the bolt finger tight at this stage.*

4. *Torque:*

Stage 1: 74 lb.ft (100 Nm)

Stage 2: 180°



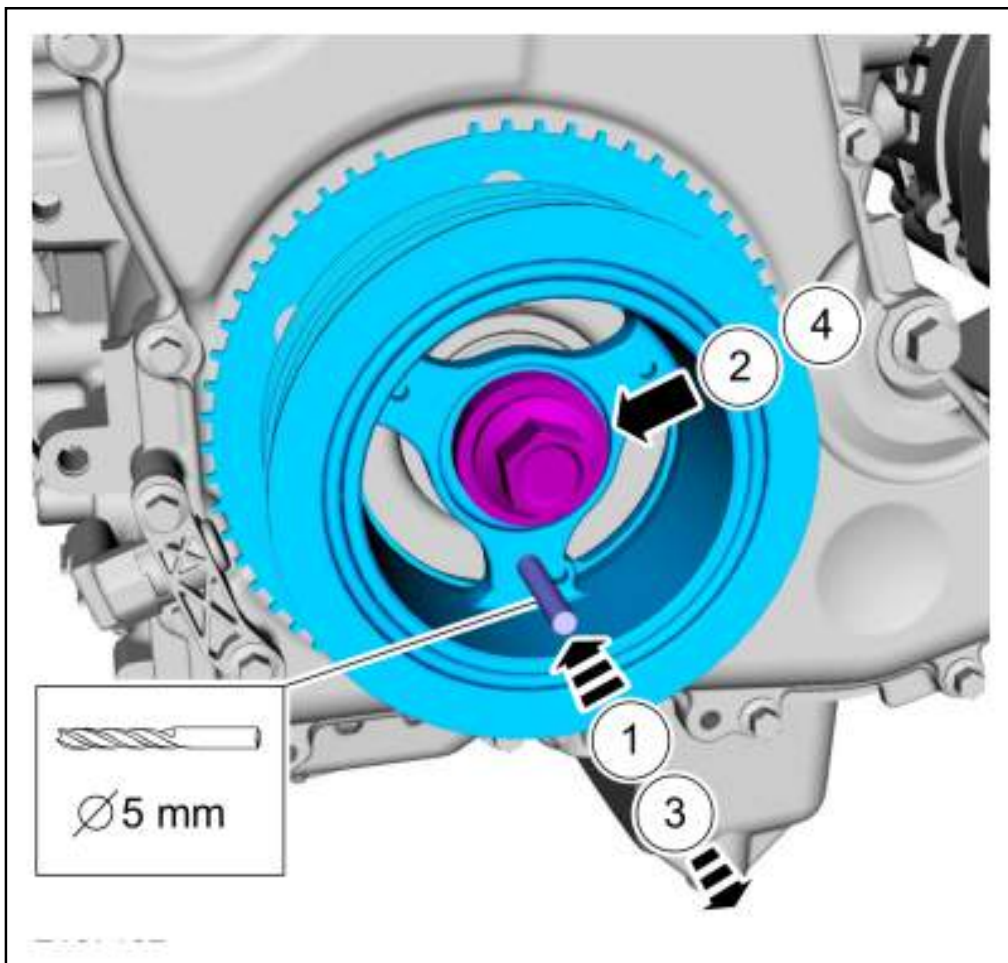

37. Remove Special Service Tool: 303-748 Locking Tool, Crankshaft.

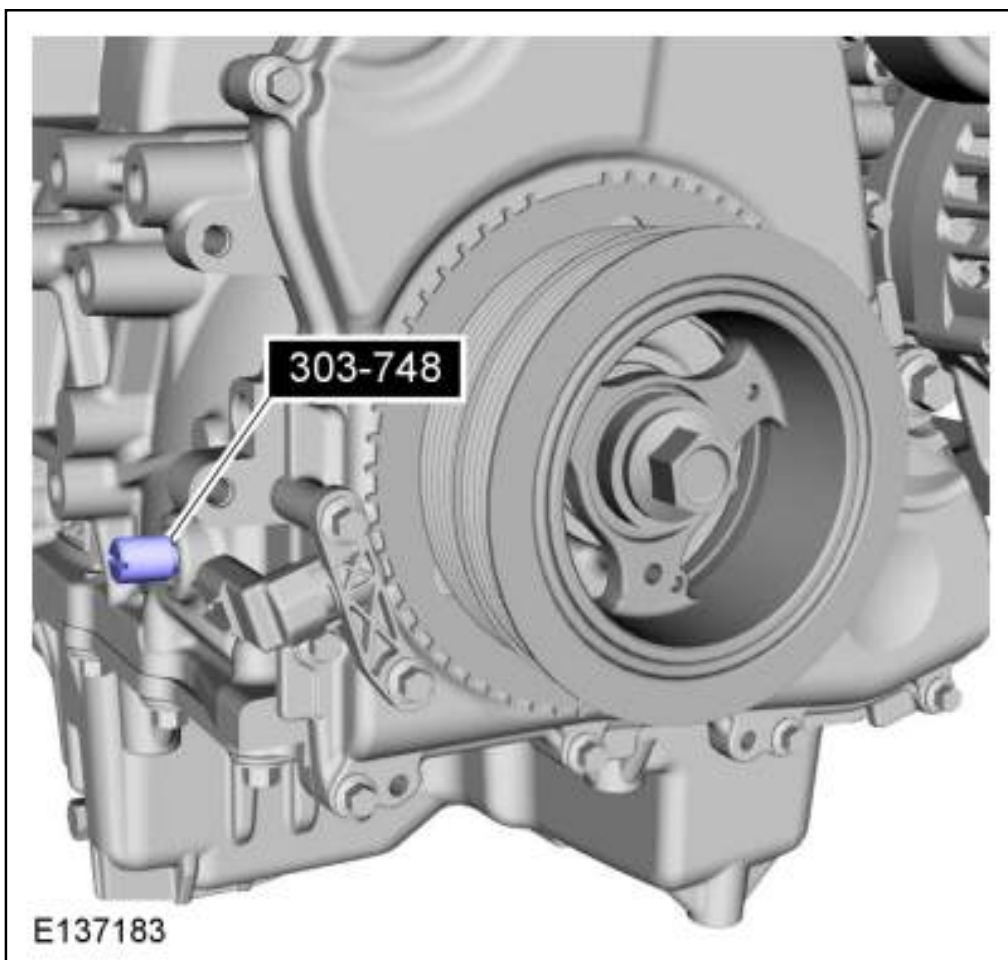

E137183

38. Remove Special Service Tool: 303-1565 Alignment Tool, Camshaft.

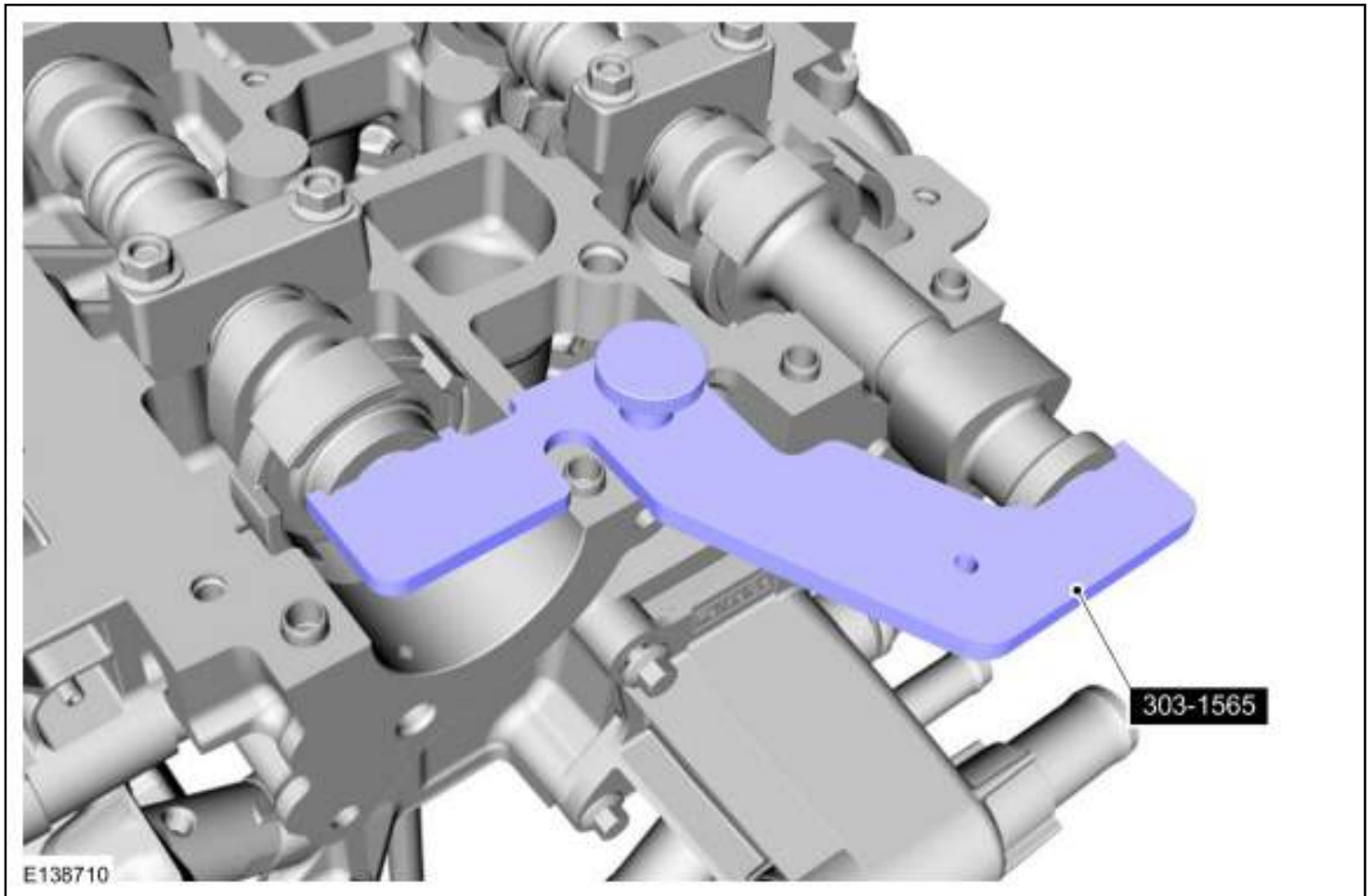

39. **NOTICE:** Only rotate the crankshaft clockwise.

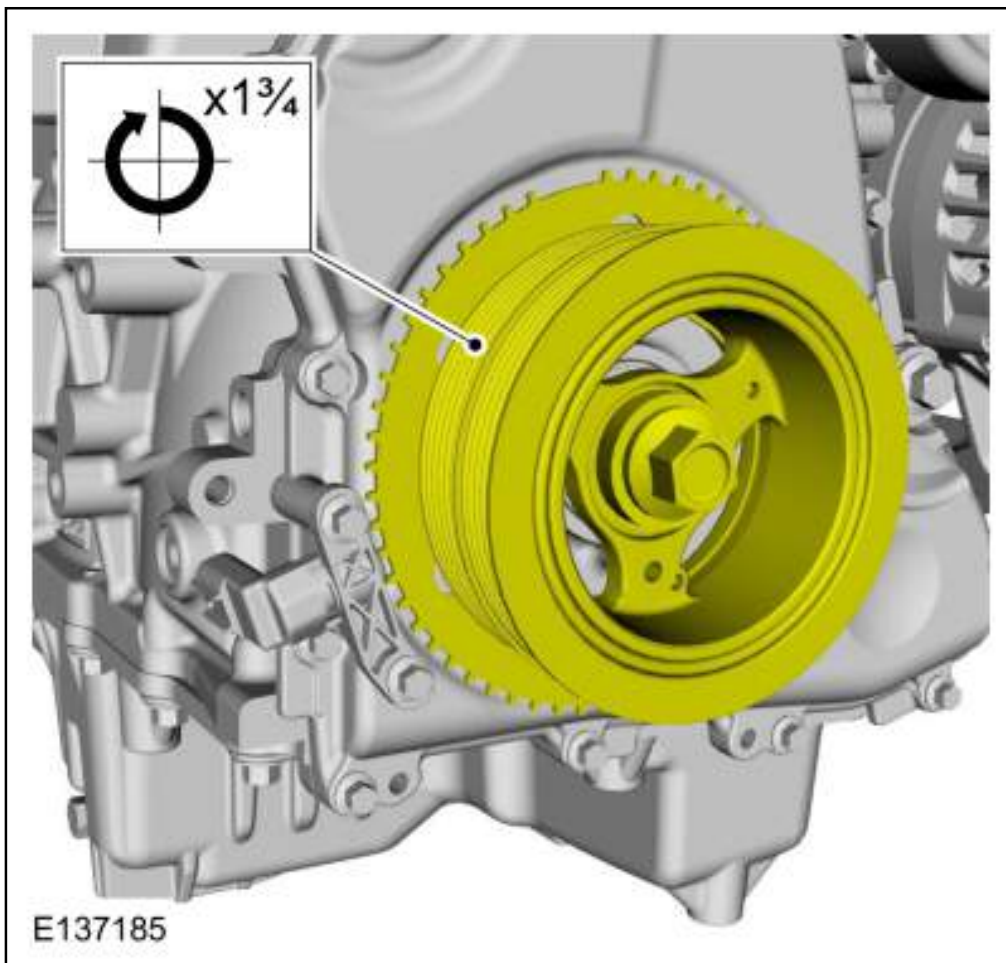

40. Install Special Service Tool: 303-748 Locking Tool, Crankshaft.

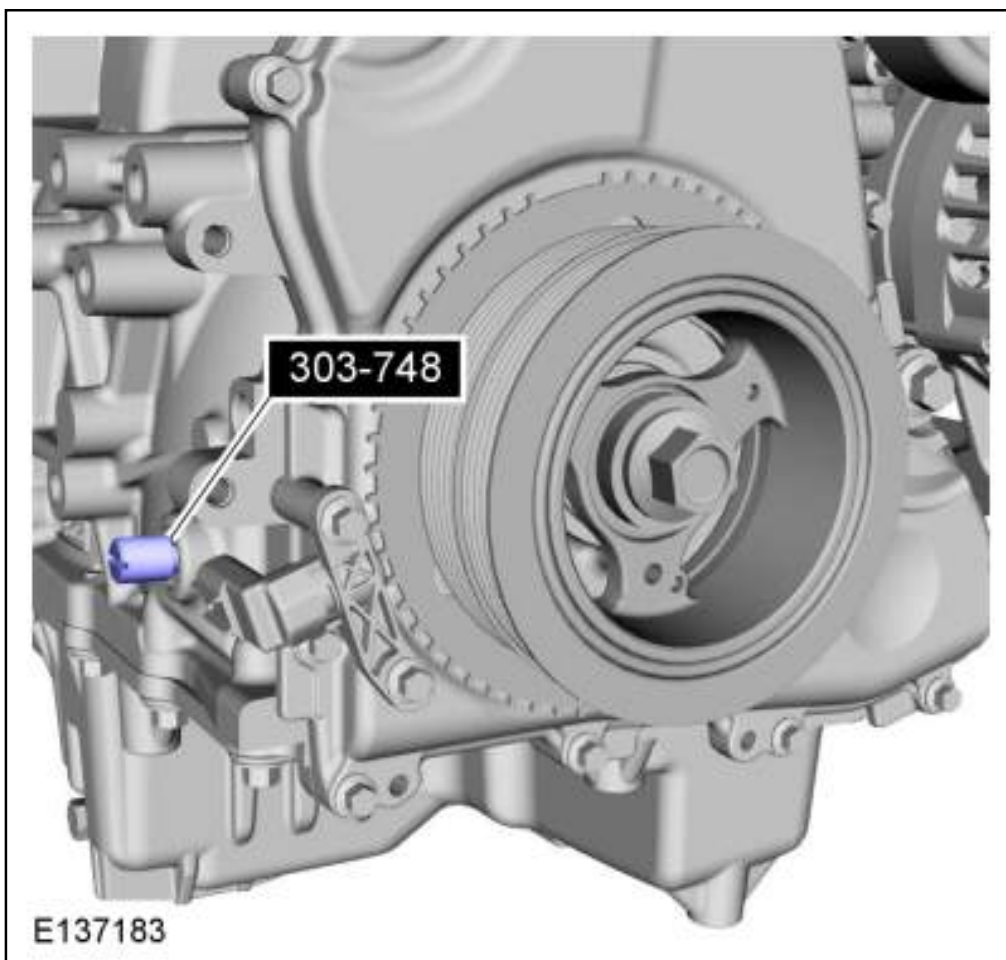

41. Rotate the crankshaft slowly until the crankshaft stops.  
Use Special Service Tool: 303-748 Locking Tool, Crankshaft.

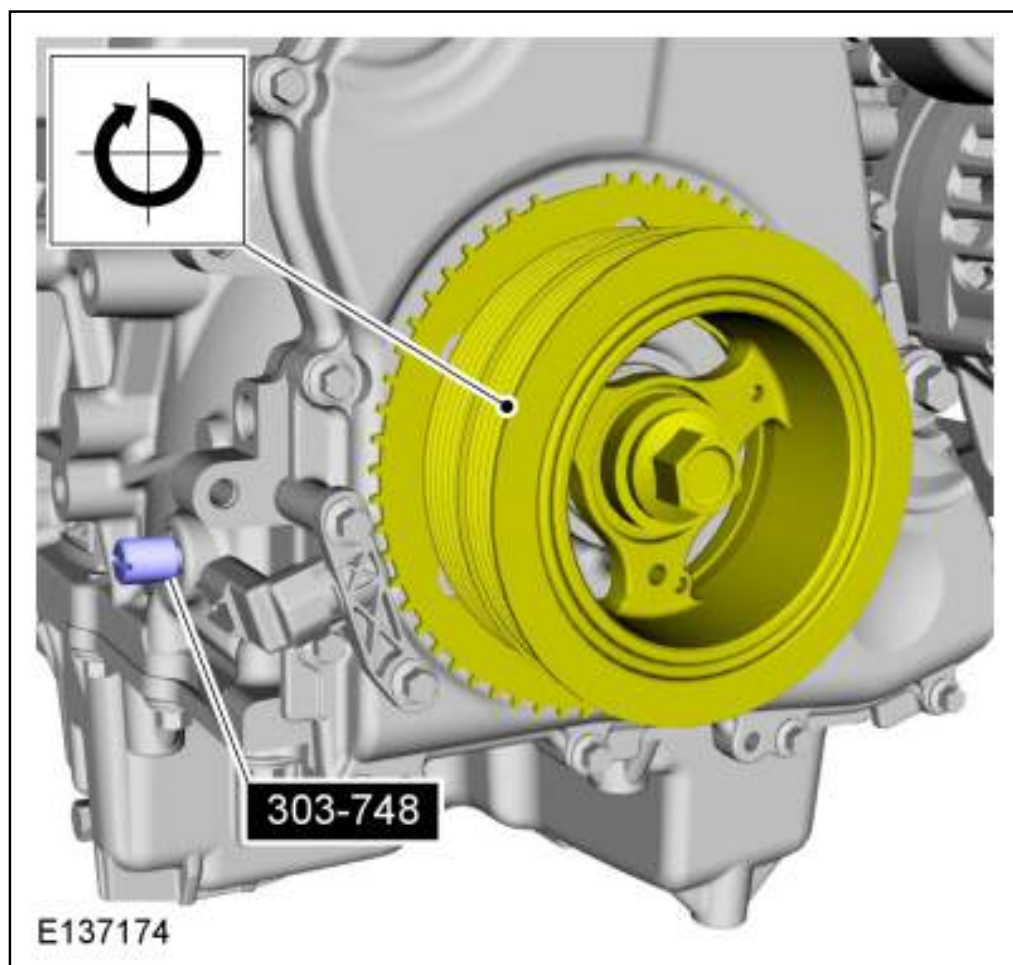

42. **NOTE:** *The special tool can only be installed if the valve timing is correct.*

Install Special Service Tool: 303-1565 Alignment Tool, Camshaft.

43. Remove Special Service Tool: 303-1565 Alignment Tool, Camshaft.

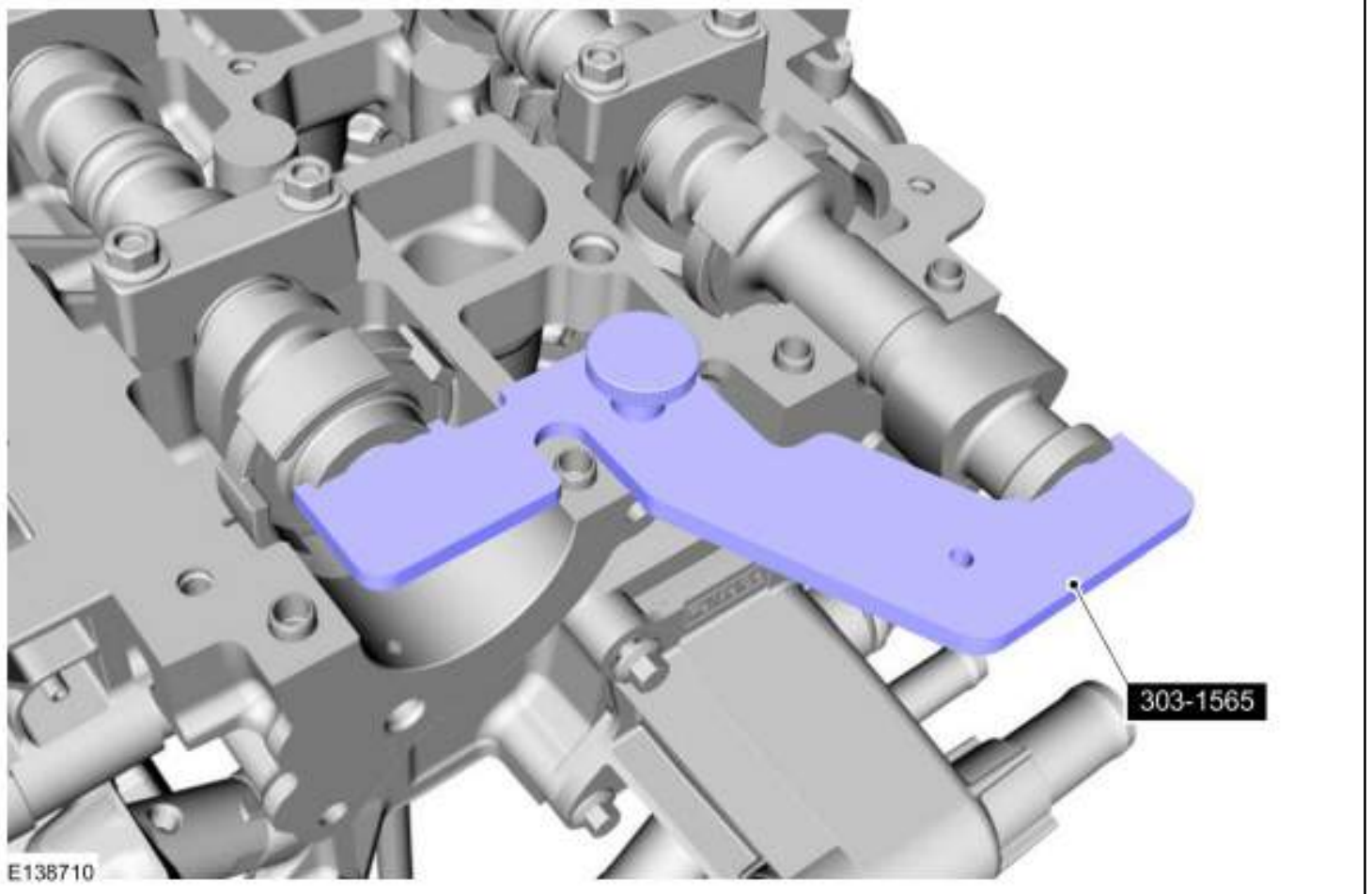

1. Remove Special Service Tool: 303-748 Locking Tool, Crankshaft.
2. *Torque*: 177 lb.in (20 Nm)

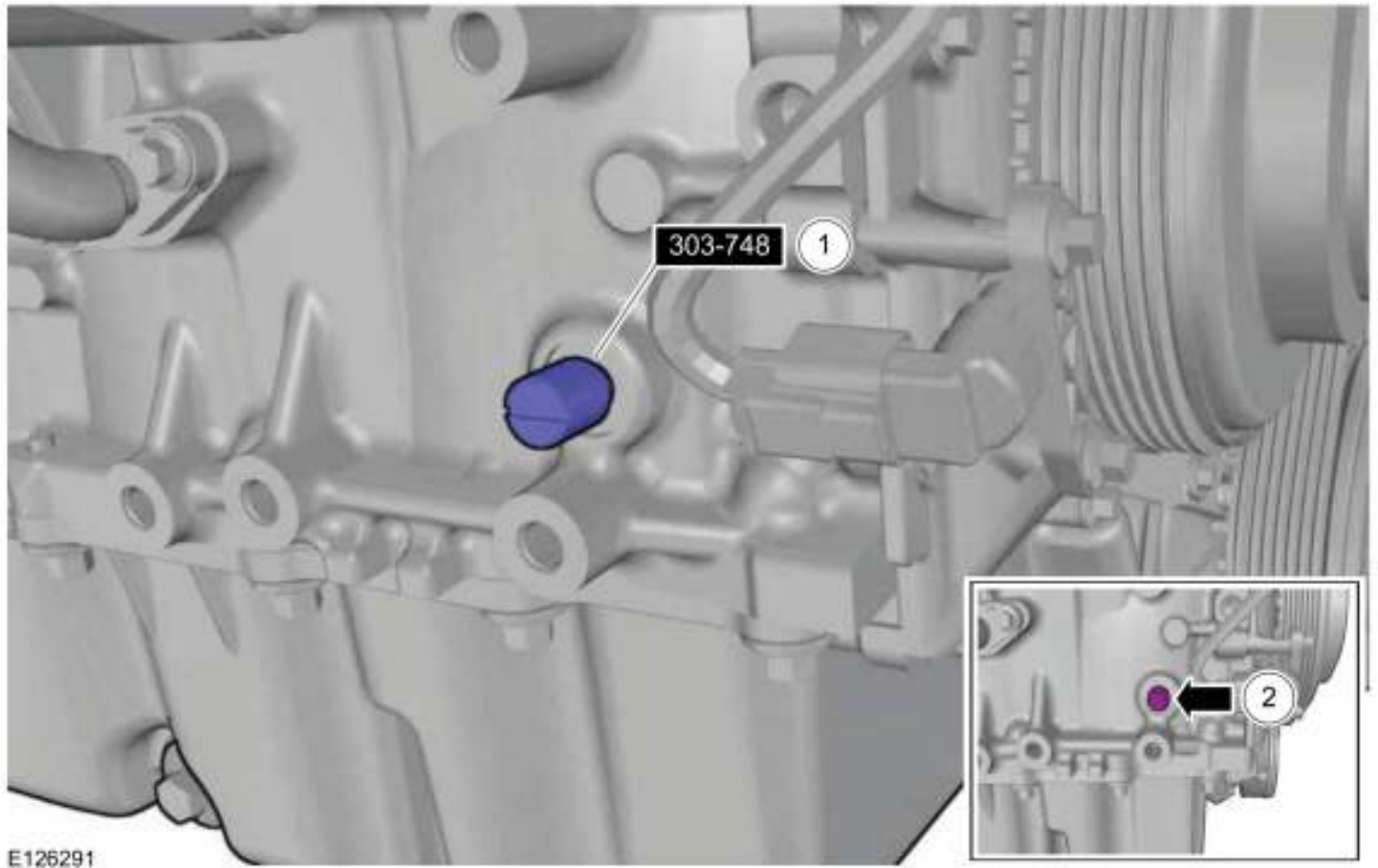

45. **NOTICE:** Use an open-ended wrench to prevent the component from turning.

*Torque:* 46 lb.ft (63 Nm)

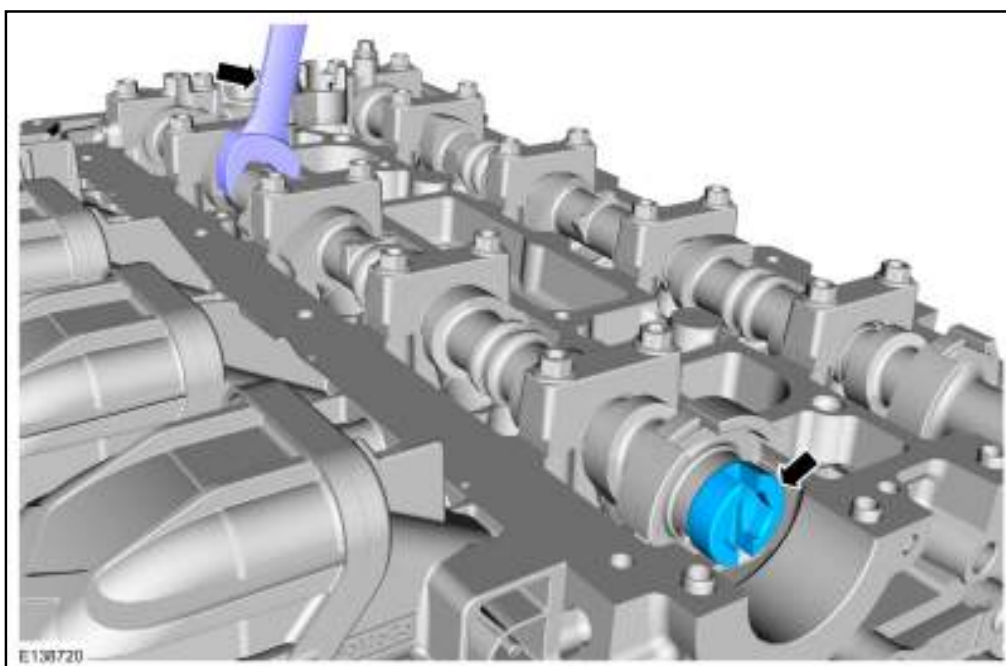

46. **NOTE:** The component must be installed within 10 minutes of applying the sealant.

*Material:* Flange Sealant / CU7Z-19B508-A (WSS-M2G348-A11)

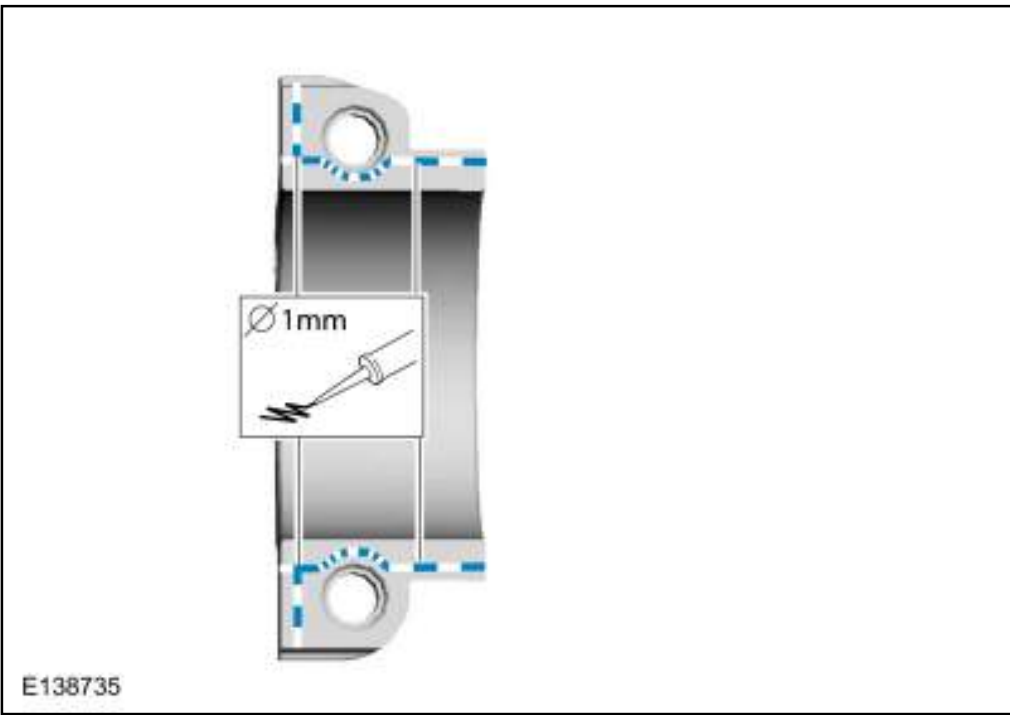

47. Tighten each bolt 2 turns at a time.

*Torque:*

Stage 1: 62 lb.in (7 Nm)

Stage 2: 142 lb.in (16 Nm)

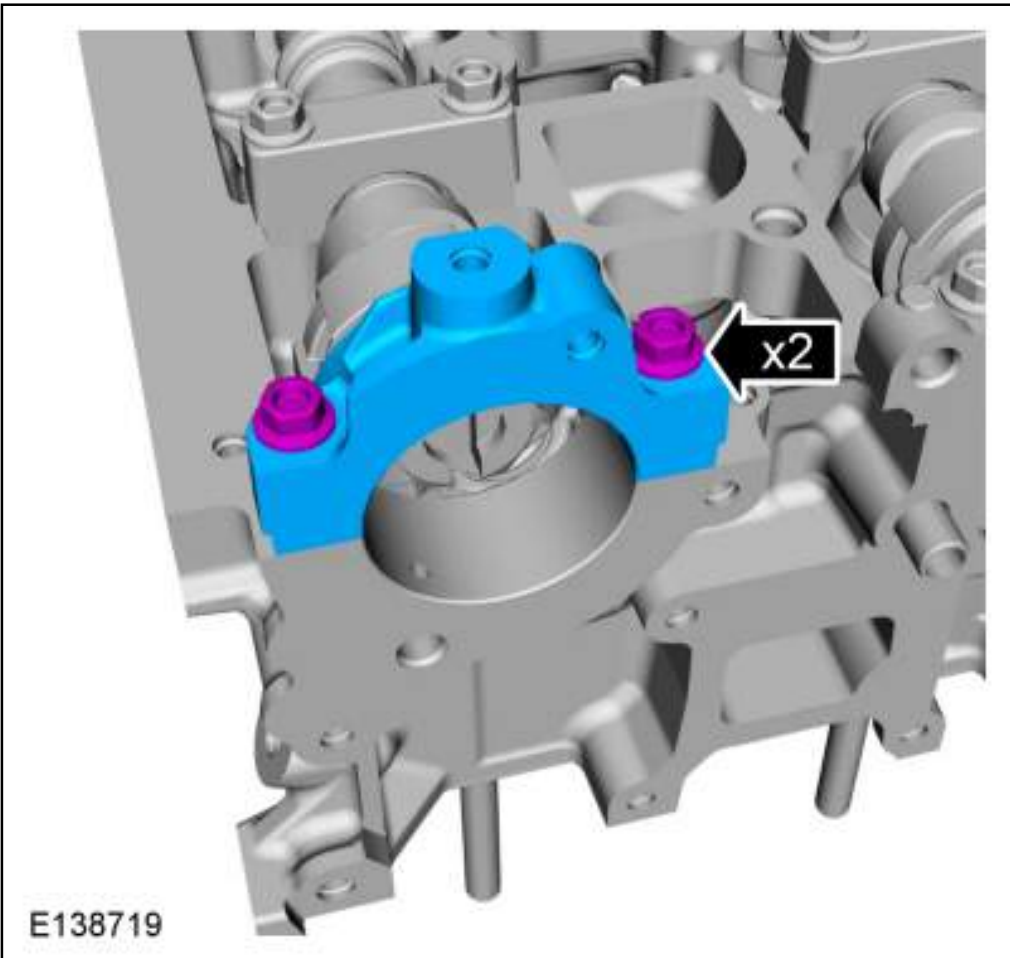

48. *Torque:*

Stage 1: 133 lb.in (15 Nm)

Stage 2: 60°

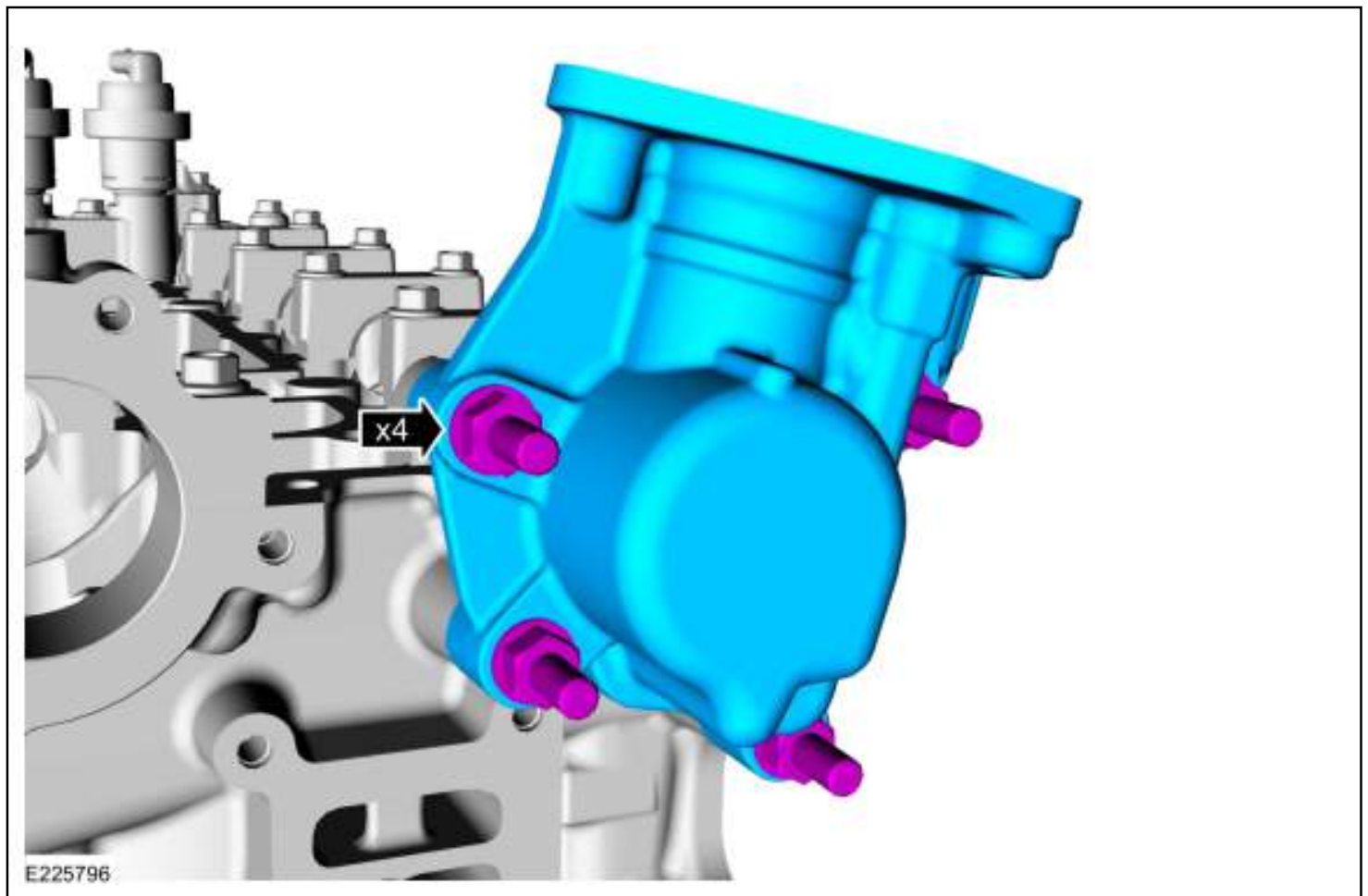

1. *Torque:* 89 lb.in (10 Nm)
2. **NOTE:** *Make sure that a new component is installed.*
3. *Torque:* 18 lb.ft (25 Nm)

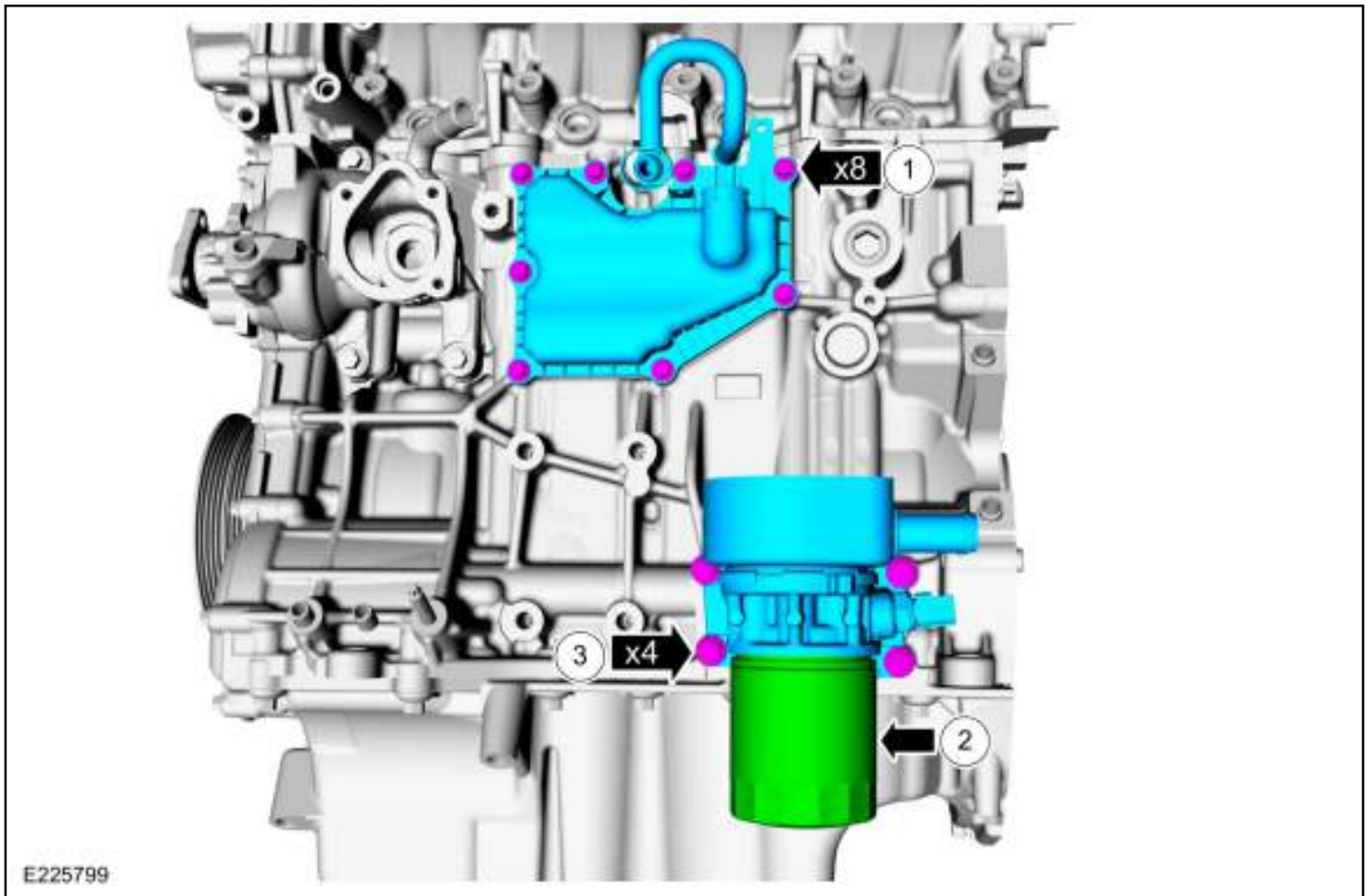

E225799

50. **NOTE:** *Make sure that new components are installed.*

Use Special Service Tool: 204-017 Installer, Wheel Hub Bearing Cup.

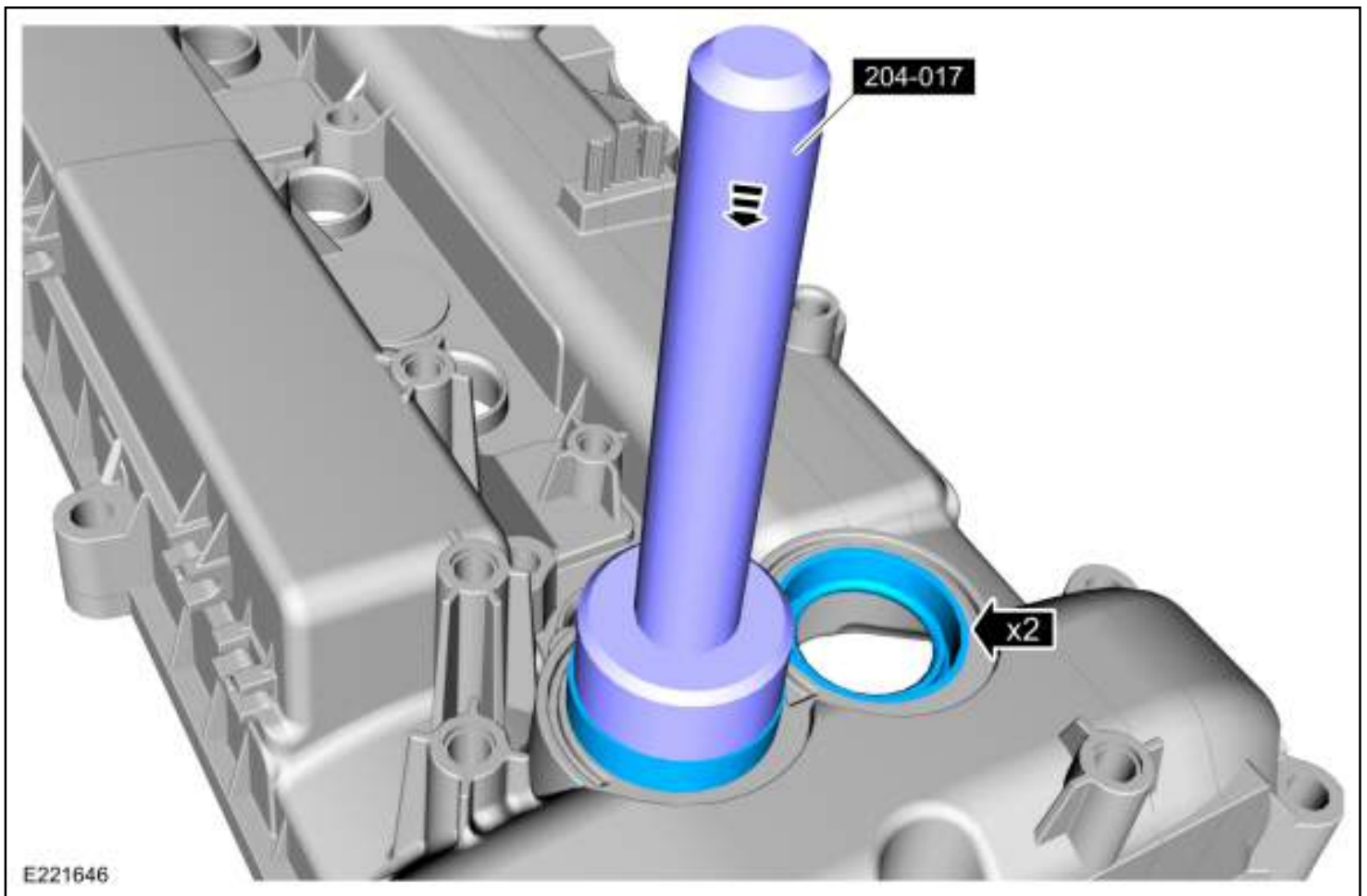

51. Use Special Service Tool: 303-499 Socket, Spark Plug.  
*Torque: 106 lb.in (12 Nm)*

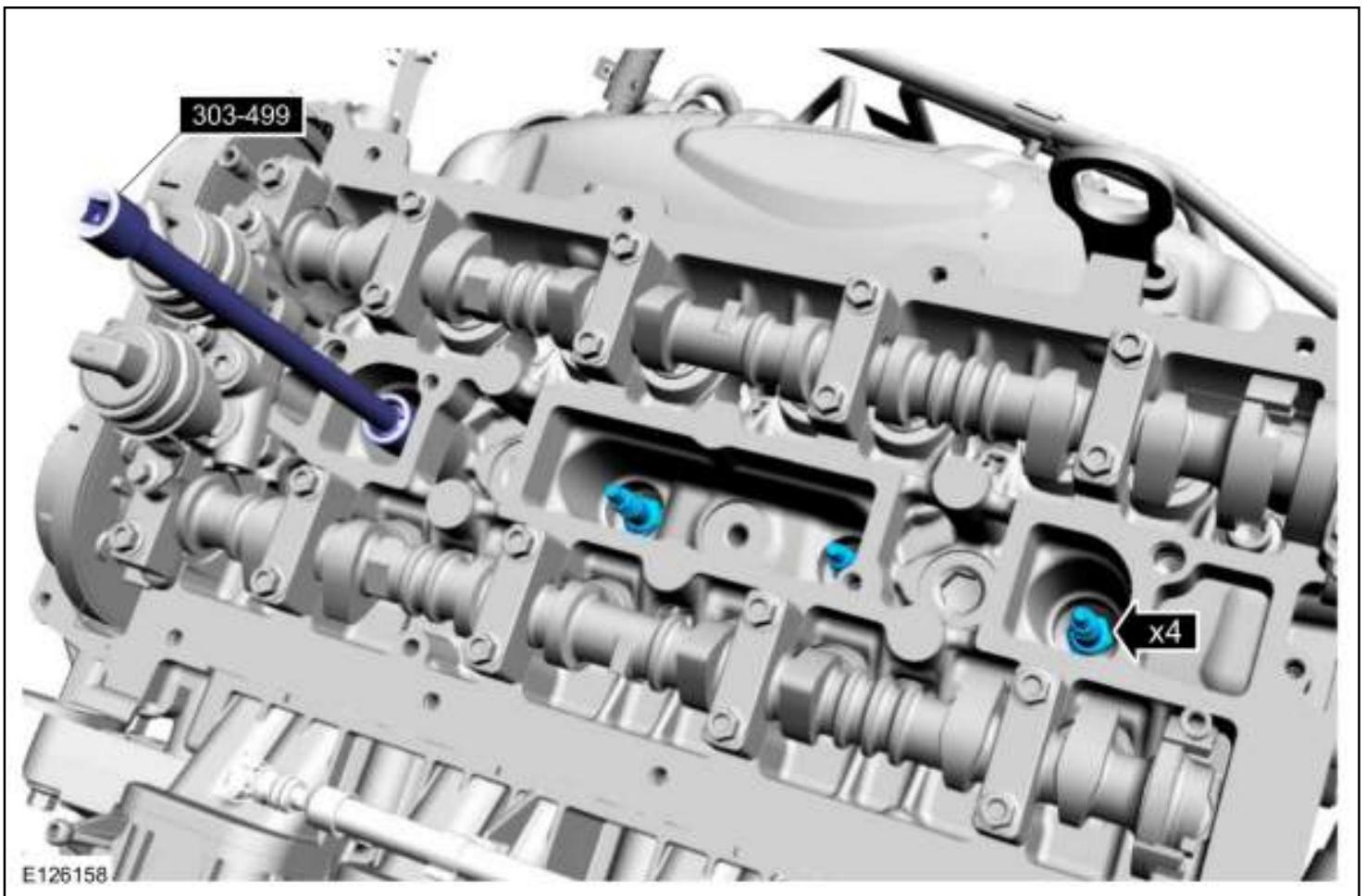

52. **NOTE:** *The component must be installed within 5 minutes of applying the sealant.*

*Material:* Motorcraft® High Performance Engine RTV Silicone / TA-357 (WSE-M4G323-A6)

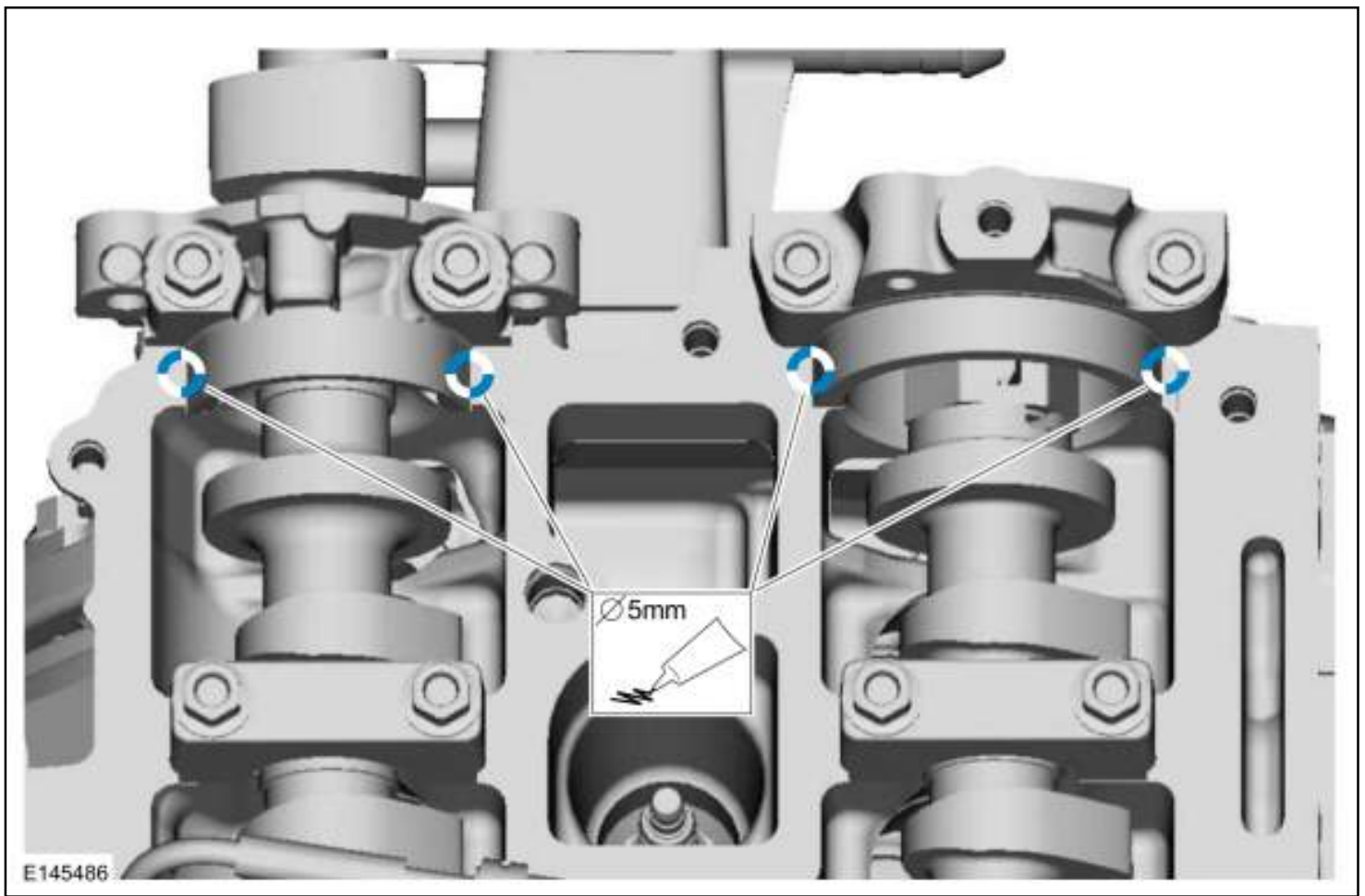

53. **NOTE:** *The component must be installed within 5 minutes of applying the sealant.*

*Material:* Motorcraft® High Performance Engine RTV Silicone / TA-357 (WSE-M4G323-A6)

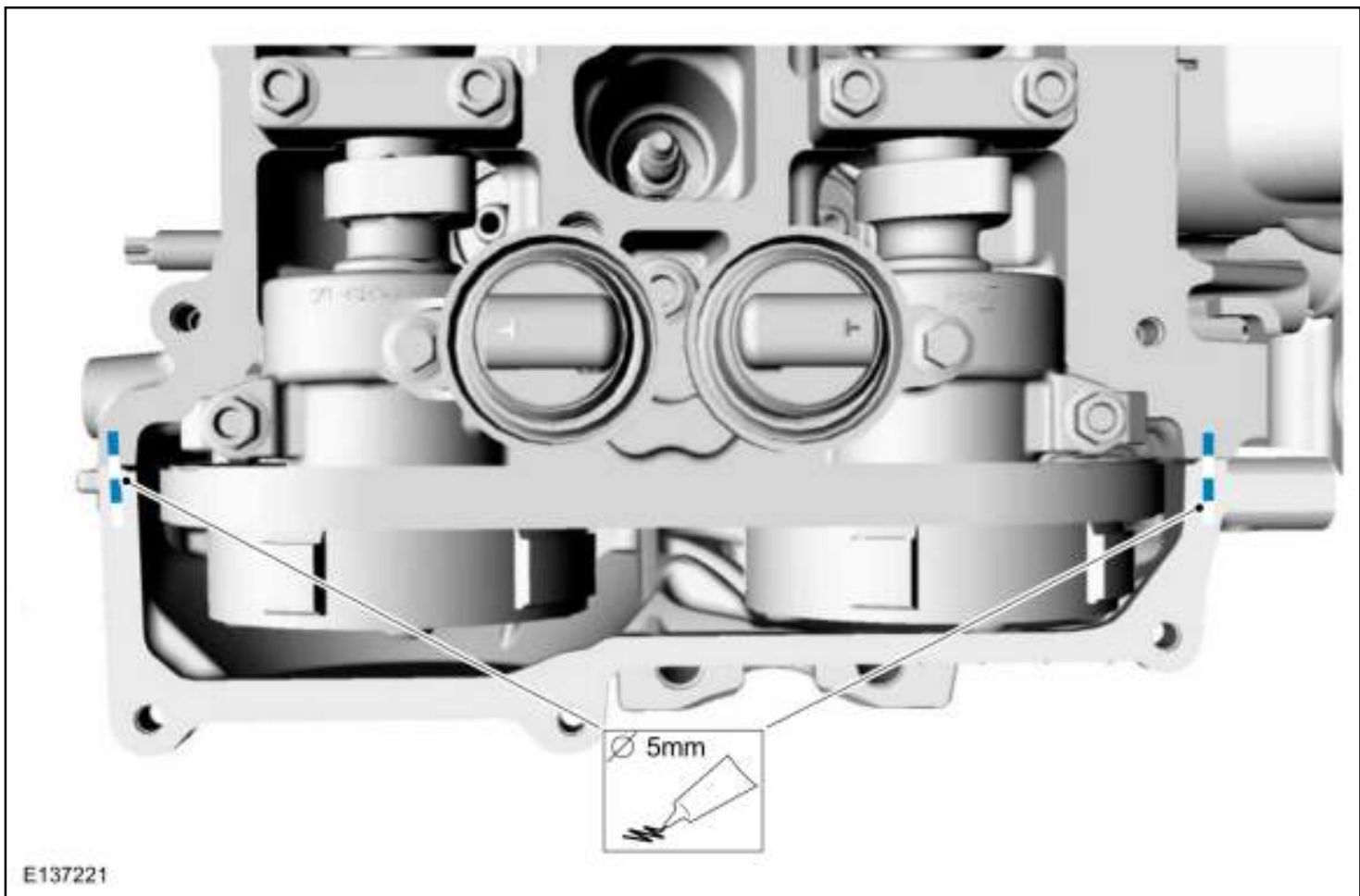

54. **NOTE:** *The gaskets are to be reused unless damaged.*

*Torque: 89 lb.in (10 Nm)*

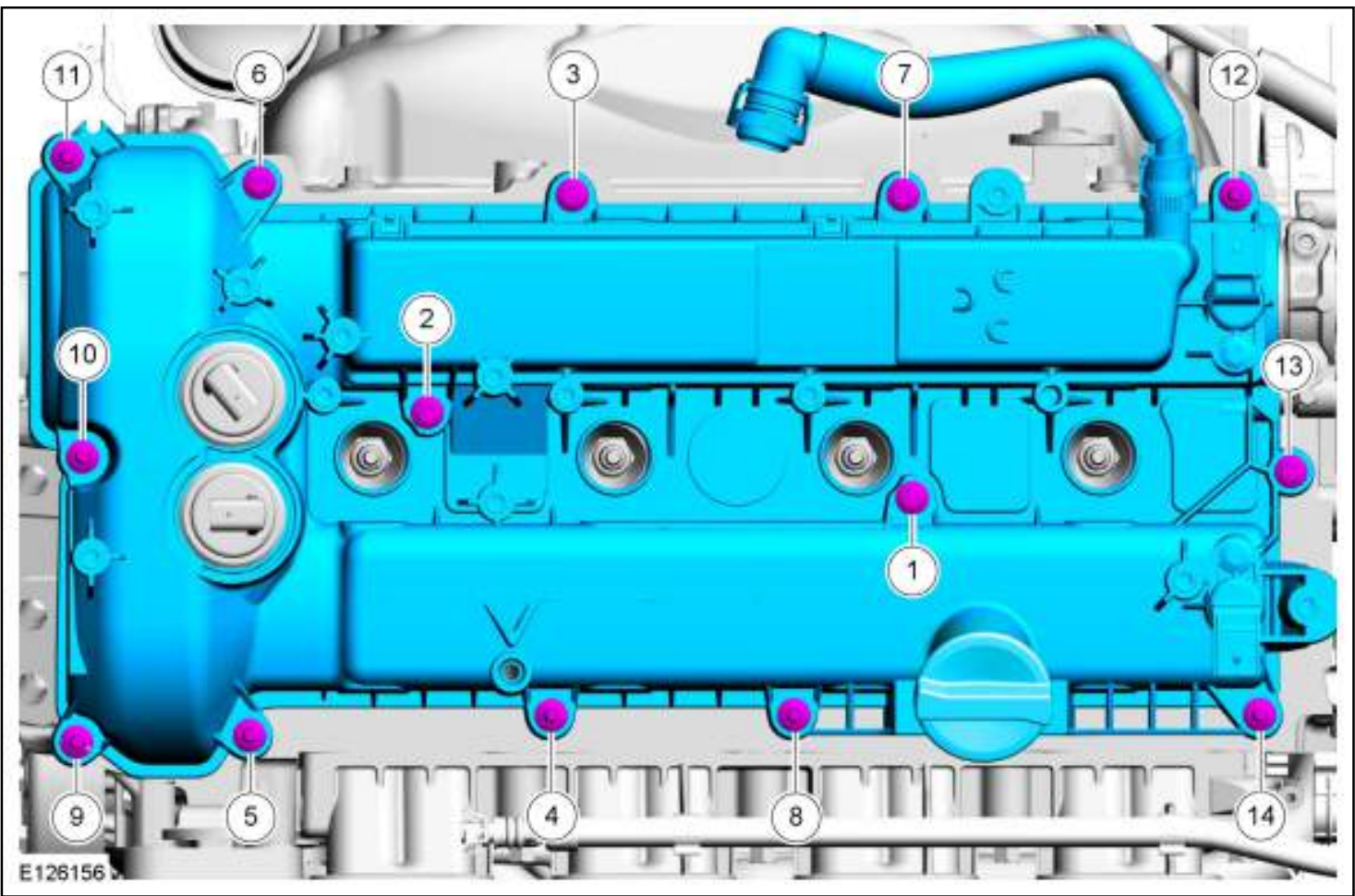



# Engine - Overview

Base Part Number: Base Part Number: 6L084

## Introduction

The exclusive variant of the newly developed and specially adapted 2.3-liter EcoBoost gasoline engine develops 257 kW (350 PS).

## The following components have been modified:

- Cylinder Head
  - New aluminum alloy (AS7GU) to improve the heat dissipation.
- Cylinder head gasket
- Exhaust-side valve springs
  - The strength of the valve springs has been reinforced
- Engine block
  - New, high-strength engine block to reduce wear at high temperatures and under high loads.
  - Machined cylinder block to make space for the transfer case
- Flywheel
  - Redesigned dual-mass flywheel to absorb vibrations and other undesired NVH (noise, vibration, harshness) error states
  - Modified DW10F clutch with 'TAC' (Travel Adjusted Clutch) technology enables higher overboost torques and is automatically adapted to the wear
- Crankshaft pulley
  - The pulley is specially adapted to the RS engine
- TC including connections
  - The TC is equipped with a new turbine and a larger compressor wheel (2.3622 in (60 mm) to 2.4803 in (63 mm)). This permits a higher boost pressure and ensures improved aerodynamics
- Crankcase ventilation
  - The flow rate has been increased from 17 liters per minute to 45 liters per minute
- Oil filter adapter seal
  - A new, synthetic oil is used for the 2.3L EcoBoost for improved lubrication and durability

## Torque and power output diagram

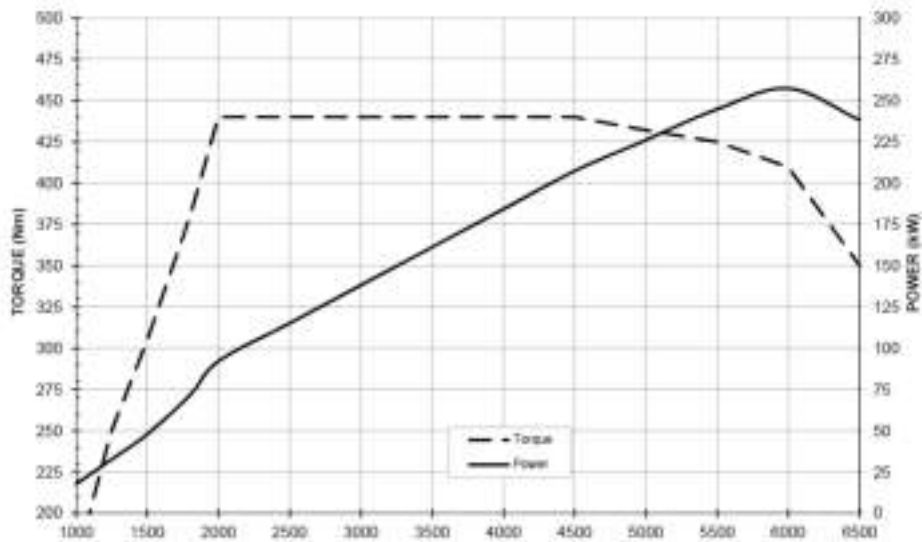

E221208

The fine-tuning of all the components gives the Focus RS an impressive operating range. It delivers a spontaneous response in the lower engine speed range, develops a high torque of 440 Nm at medium engine speeds and makes it constantly available between 2000 and 4500 rpm, and peaks at 6800 rpm. The overboost control increases the maximum torque to 470 Nm for 15 seconds under full acceleration.

Copyright © 2019 Ford Motor Company

cardiagn.com



## Engine - Component Location

Base Part Number: Base Part Number: 6L084

### Front view of engine

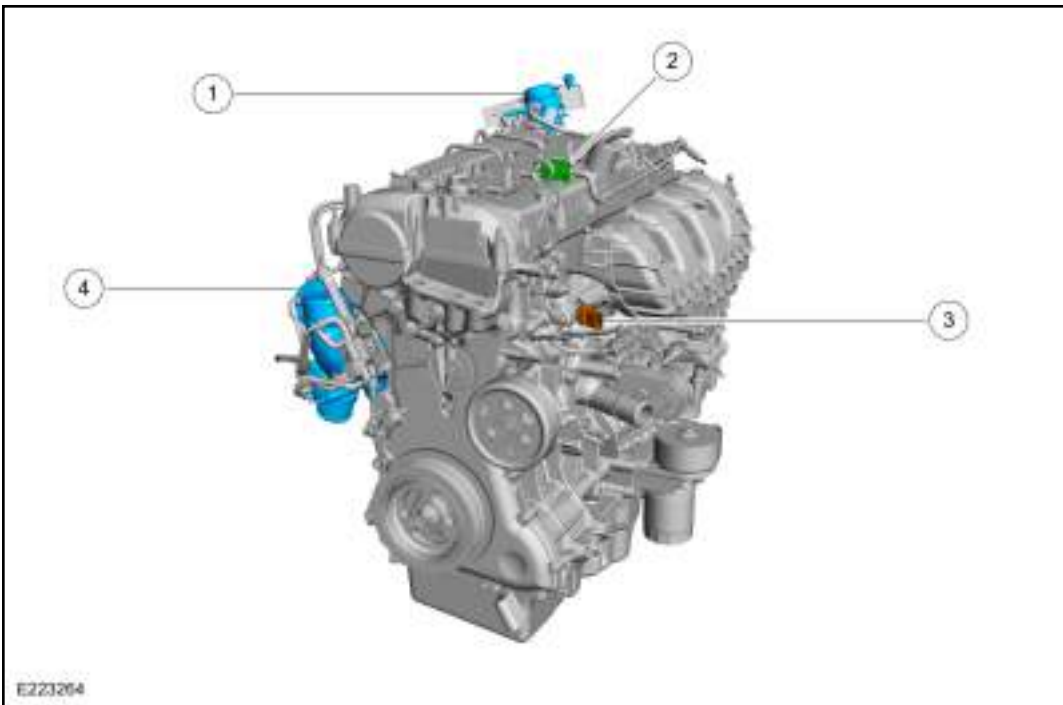

cardiagn.com

Item	Description
1	High-pressure fuel pump
2	Recirculated air valve solenoid
3	Fuel pressure sensor
4	TC

### Rear view of engine

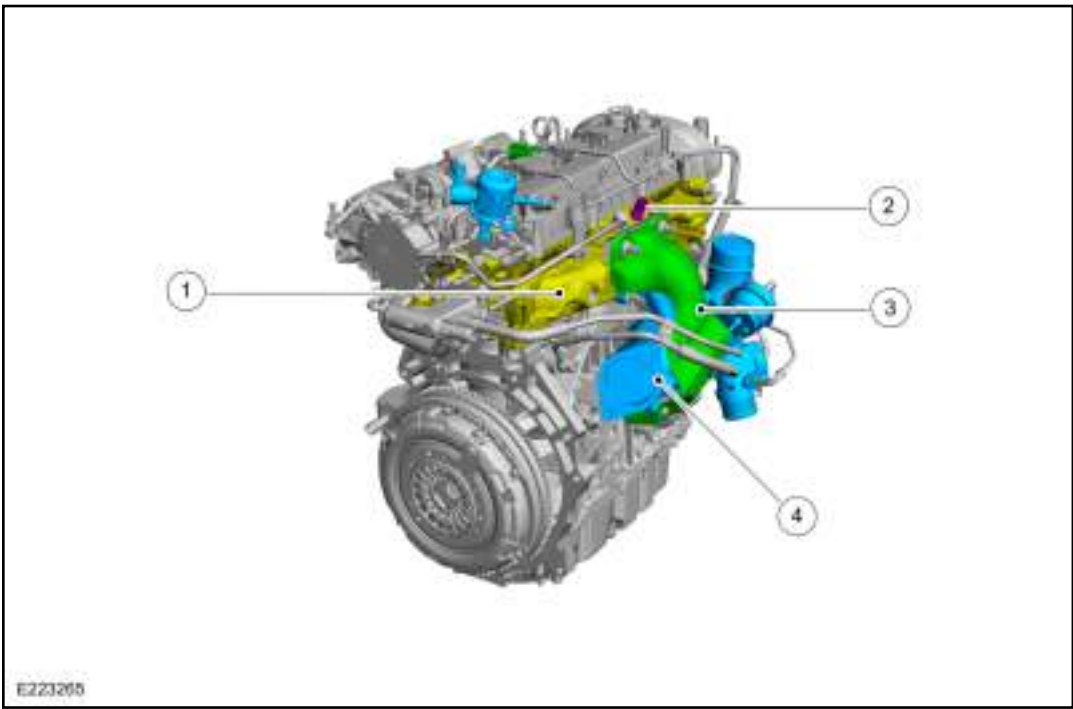

Item	Description
1	Cylinder Head <b>Comments:</b> with integrated exhaust manifold
2	Exhaust gas temperature sensor
3	TC heat shield
4	TC

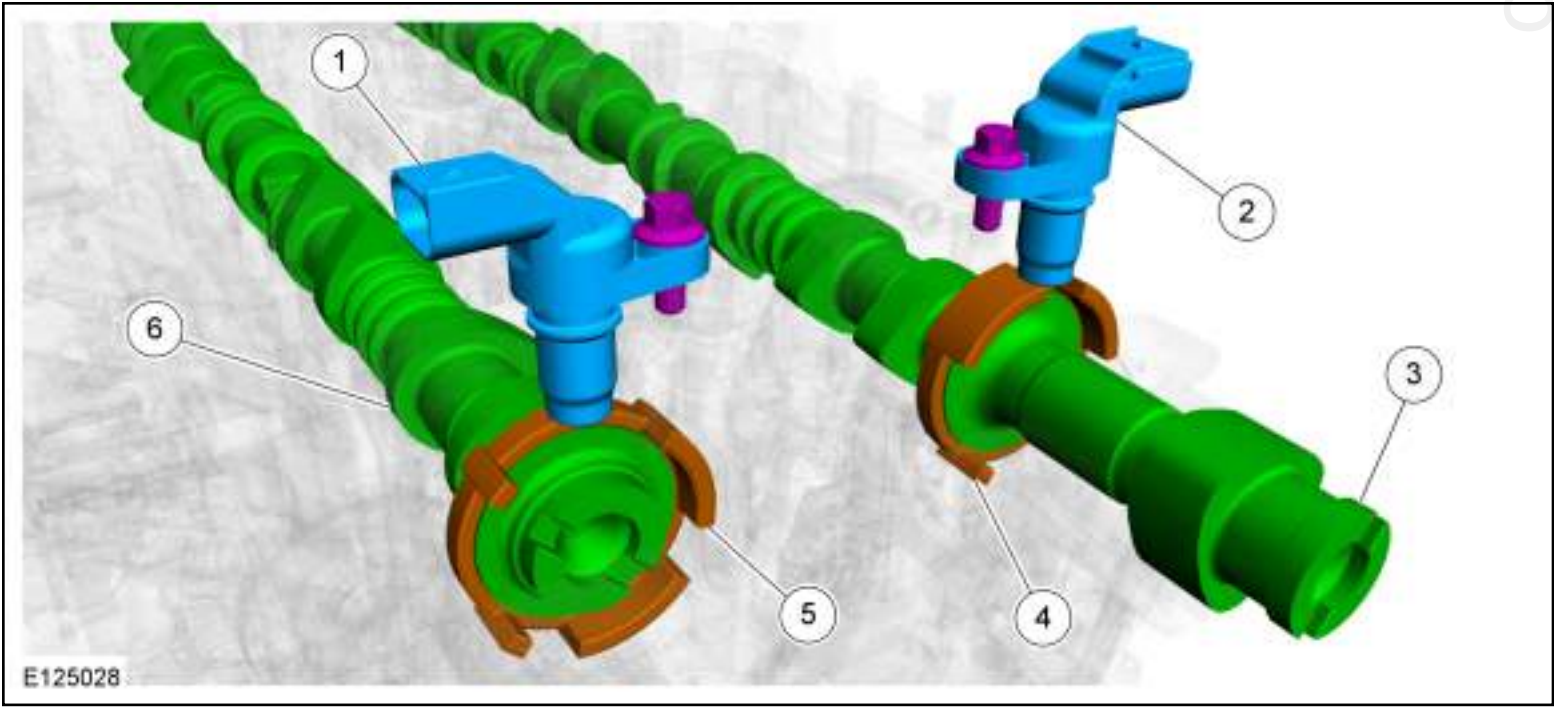

<b>Item</b>	<b>Description</b>
1	CMP Sensor - intake camshaft
2	CMP Sensor - exhaust camshaft
3	Exhaust camshaft
4	Exhaust camshaft CMP sensor ring
5	Intake camshaft CMP sensor ring
6	Intake camshaft

Copyright © 2019 Ford Motor Company

---

# Engine

Base Part Number: Base Part Number: 6L084

## Special Tool(s)

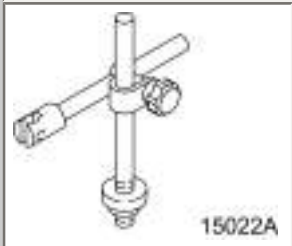
	Dial Indicator Gauge (Metric) 205-069
	Holding Fixture, Dial Indicator Gauge 205-070

## General Equipment

Ford diagnostic equipment
Ultraviolet (UV) leak tester
Compression tester
Engine oil pressure gauge

## Material

Item	Specification
Adhesive - Loctite 243	WSK-M2G349-A7

## Inspection and Verification - Engine Performance

**NOTE:** There are 2 diagnostic paths that can be followed depending on the type of engine concern. Carry out Inspection and Verification - Engine Performance or Inspection and Verification - NVH.

1. Verify the customer concern.
2. Visually inspect for obvious signs of mechanical damage.

3. If an obvious cause for an observed or reported concern is found, correct the cause (if possible) before proceeding to the next step.
4. **NOTE:** *Make sure that the latest Ford diagnostic equipment software release is used.*

If the cause is not visually evident, refer to the Ford diagnostic equipment to diagnose the system.

5. If no DTCs related to the concern are retrieved, GO to Symptom Chart - Engine Performance.

## **Inspection and Verification - NVH**

1. Verify the customer concern.
2. Check the engine oil level and check the oil for contamination. Low engine oil level or contaminated oil are a common cause of engine noise. If the oil is contaminated, the source of the contamination must be identified and repaired as necessary.
3. Visually inspect for obvious signs of mechanical damage.
4. If an obvious cause for an observed or reported concern is found, correct the cause (if possible) before proceeding to the next step.
5. **NOTE:** *Make sure that the latest Ford diagnostic equipment software release is used.*

If the cause is not visually evident, refer to the Ford diagnostic equipment to diagnose the system.

6. If no DTCs related to the concern are retrieved, continue the inspection and verification if a noise concern is related to the engine. For vibration concerns and noise concerns such as powertrain mounts, air intake system and starter GO to Symptom Chart - NVH.

In some cases, a noise may be a normal characteristic of that engine type. In other cases the noise may require further investigation. Comparing the noise to a similar year/model vehicle equipped with the same engine will aid in determining if the noise is normal or abnormal.

When a customer concern has been identified as an abnormal engine noise, it is critical to determine the location of the specific noise. Use a stethoscope (the noise will always be louder closer to the noise source) to isolate the location of the noise to one of the following areas.

- Fuel injector(s)
- Upper end of engine
- Lower end of engine

## Fuel injector noise

A common source of an engine ticking noise can be related to the fuel injection pump or fuel injector (s). This is normal engine noise that can be verified by listening to another vehicle. If the fuel injector noise is excessive or irregular, use a stethoscope to isolate the noise to a specific fuel injector.

## Upper end engine noise

A common source of upper end engine noise (ticking, knocking or rattle) include the camshaft(s) and valve train. Upper end engine noise can be determined using a stethoscope on the valve cover bolts. If the noise is loudest from the valve cover bolts, then the noise is upper end. A stethoscope can be used to further isolate the noise to the specific cylinder bank and cylinder. Removal of the valve cover will be required to pinpoint the source of the noise.

## Lower end engine noise

A common source of lower end engine noise (ticking or knocking) include the crankshaft, connecting rod(s) and bearings. Lower end noises can be determined by using the oil pan or lower cylinder block. If the noise is loudest from these areas, then the noise is lower end. If an engine noise is isolated to the lower end, some disassembly of the engine may be required to inspect for damage or wear.

Some other noises from the front of the engine (ticking, tapping or rattle) may be internal to the engine. Use a stethoscope on the engine front cover to determine if the noise is internal to the engine. Removal of the engine front cover may be necessary to inspect internal engine components.

## Symptom Chart

Symptom	Possible Sources	Action
<ul style="list-style-type: none"><li>Loss of oil</li></ul>	<ul style="list-style-type: none"><li>Oil leaks on components that are either coated in oil themselves or on components local to them.</li></ul>	<ul style="list-style-type: none"><li>CHECK for evidence of oil leaks on components. Use an ultraviolet (UV) leak tester if an oil leak is not evident. INSTALL new gaskets or components as required.</li></ul>

<ul style="list-style-type: none"> <li>● Crankshaft front seal.</li> </ul>	<ul style="list-style-type: none"> <li>● INSTALL a new crankshaft front seal. REFER to: <a href="#">Crankshaft Front Seal</a> (303-01C Engine, Removal and Installation).</li> </ul>
<ul style="list-style-type: none"> <li>● Crankshaft rear seal.</li> </ul>	<ul style="list-style-type: none"> <li>● INSTALL a new crankshaft rear seal. REFER to: <a href="#">Crankshaft Rear Seal</a> (303-01C Engine, Removal and Installation).</li> </ul>
<ul style="list-style-type: none"> <li>● Leaks from oil carrying components or basic engine.</li> </ul>	<ul style="list-style-type: none"> <li>● CHECK for cracks in oil carrying components of the basic engine by means of an ultraviolet UV leak tester. INSTALL new components or seals as necessary.</li> </ul>
<ul style="list-style-type: none"> <li>● Oil consumption</li> </ul>	<ul style="list-style-type: none"> <li>● Use of the wrong type of engine oil.</li> <li>● INSTALL a new engine oil filter and the correct engine oil. REFER to: <a href="#">Specifications</a> (303-01C Engine, Specifications).</li> </ul>
<ul style="list-style-type: none"> <li>● Faulty positive crankcase ventilation (PCV) system.</li> <li>● Hoses or ventilation or breather valves are blocked. This causes excessive pressure in the crankcase which causes more oil to enter the combustion chamber.</li> </ul>	<ul style="list-style-type: none"> <li>● CHECK if the PCV system is operating correctly and repair as necessary. REFER to: Engine Emission Control (303-08A) .</li> </ul>

<ul style="list-style-type: none"> <li>● PCV oil separator is faulty and engine oil can enter the combustion chamber through the intake manifold.</li> </ul>	
<ul style="list-style-type: none"> <li>● Damaged gaskets or mating surfaces.</li> <li>● Cylinder head gasket is damaged or mating face are warped.</li> </ul>	<ul style="list-style-type: none"> <li>● Remove the cylinder head. REFER to: <a href="#">Cylinder Head</a> (303-01C Engine, Removal and Installation). CHECK the mating faces, cylinder head gasket and the evenness of the cylinder head and engine block mating faces.</li> </ul>
<ul style="list-style-type: none"> <li>● Valve stem seals.</li> <li>● Engine oil can enter the combustion chamber between the valve stem and the valve stem guide.</li> </ul>	<ul style="list-style-type: none"> <li>● <b>INSTALL</b> new valve stem seals.</li> </ul>
<ul style="list-style-type: none"> <li>● Piston ring or cylinder liner wear.</li> </ul>	<ul style="list-style-type: none"> <li>● <b>INSTALL</b> new components as necessary.</li> </ul>



<ul style="list-style-type: none"> <li>● Engine does not crank</li> </ul>	<ul style="list-style-type: none"> <li>● Passive anti-theft system (PATS).</li> </ul>	<ul style="list-style-type: none"> <li>● CHECK the PATS LED extinguishes within 3 seconds when the ignition is turned on. REFER to: Passive Anti-Theft System (PATS) (419-01B) .</li> </ul>
	<ul style="list-style-type: none"> <li>● Starting system.</li> </ul>	<ul style="list-style-type: none"> <li>● CHECK the starting system. REFER to: Starting System (303-06A) .</li> </ul>
	<ul style="list-style-type: none"> <li>● Front controls interface module (FCIM)</li> <li>● Body control module (BCM)</li> <li>● Powertrain control module (PCM).</li> </ul>	<ul style="list-style-type: none"> <li>● REFER to the Ford diagnostic equipment.</li> </ul>
<ul style="list-style-type: none"> <li>● Engine cranks but does not start</li> </ul>	<ul style="list-style-type: none"> <li>● Fuel tank fuel level low.</li> </ul>	<ul style="list-style-type: none"> <li>● CHECK the fuel level.</li> </ul>
	<ul style="list-style-type: none"> <li>● Fuel filter blocked.</li> </ul>	<ul style="list-style-type: none"> <li>● INSTALL a new fuel filter.</li> </ul>
	<ul style="list-style-type: none"> <li>● Engine intake air system.</li> </ul>	<ul style="list-style-type: none"> <li>● CHECK the intake air system. REFER to: Intake Air Distribution and Filtering (303-12A) .</li> </ul>
	<ul style="list-style-type: none"> <li>● Engine management system.</li> </ul>	<ul style="list-style-type: none"> <li>● CHECK the engine management system. REFER to: Electronic Engine Controls (303-14A) .</li> </ul>

<ul style="list-style-type: none"> <li>● Ignition system.</li> </ul>	<ul style="list-style-type: none"> <li>● CHECK the ignition system. REFER to: Engine Ignition (303-07A) .</li> </ul>
<ul style="list-style-type: none"> <li>● Incorrect valve timing.</li> </ul>	<ul style="list-style-type: none"> <li>● CHECK and adjust the valve timing. REFER to: <a href="#">Timing Chain</a> (303-01C Engine, Removal and Installation).</li> </ul>
<ul style="list-style-type: none"> <li>● Broken or damaged timing chain or pulley (s).</li> </ul>	<ul style="list-style-type: none"> <li>● CHECK the timing chain and pulley(s). INSTALL new components as necessary. REFER to: <a href="#">Timing Chain</a> (303-01C Engine, Removal and Installation).</li> </ul>
<ul style="list-style-type: none"> <li>● Very poor power output or fuel consumption too high or engine running rough</li> </ul>	<ul style="list-style-type: none"> <li>● FUEL system.</li> <li>● CHECK the fuel system. REFER to: Fuel System (310-00A) .</li> </ul>
<ul style="list-style-type: none"> <li>● Engine intake air system.</li> </ul>	<ul style="list-style-type: none"> <li>● CHECK the intake air system. REFER to: Intake Air Distribution and Filtering (303-12A) .</li> </ul>
<ul style="list-style-type: none"> <li>● Exhaust system blocked.</li> </ul>	<ul style="list-style-type: none"> <li>● CHECK the exhaust system.</li> </ul>

<ul style="list-style-type: none"> <li>● Engine management system.</li> </ul>	<ul style="list-style-type: none"> <li>● CHECK the engine management system. REFER to: Electronic Engine Controls (303-14A) .</li> </ul>
<ul style="list-style-type: none"> <li>● Fault in ignition system.</li> </ul>	<ul style="list-style-type: none"> <li>● CHECK the ignition system. REFER to: Engine Ignition (303-07A) .</li> </ul>
<ul style="list-style-type: none"> <li>● Incorrect valve timing.</li> </ul>	<ul style="list-style-type: none"> <li>● CHECK and adjust the valve timing. REFER to: <a href="#">Timing Chain</a> (303-01C Engine, Removal and Installation).</li> </ul>
<ul style="list-style-type: none"> <li>● Broken or damaged timing chain or pulley (s).</li> </ul>	<ul style="list-style-type: none"> <li>● CHECK the timing chain and pulley(s). INSTALL new components as necessary. REFER to: <a href="#">Timing Chain</a> (303-01C Engine, Removal and Installation).</li> </ul>
<ul style="list-style-type: none"> <li>● Noisy running</li> </ul>	<ul style="list-style-type: none"> <li>● Engine auxiliary components loose or damaged.</li> </ul>
<ul style="list-style-type: none"> <li>● Noisy running, misfiring, backfiring or knocking</li> </ul>	<ul style="list-style-type: none"> <li>● DETERMINE which type of fuel was last put in the tank (note the country specific fuel specifications).</li> </ul>

<ul style="list-style-type: none"> <li>• Water in fuel or fuel contaminated.</li> </ul>	<ul style="list-style-type: none"> <li>• CHECK the fuel system for water or other contamination.</li> </ul>
<ul style="list-style-type: none"> <li>• Incorrect valve timing.</li> </ul>	<ul style="list-style-type: none"> <li>• CHECK and adjust the valve timing. REFER to: <a href="#">Timing Chain</a> (303-01C Engine, Removal and Installation).</li> </ul>
<ul style="list-style-type: none"> <li>• Broken or damaged timing chain or pulley (s).</li> </ul>	<ul style="list-style-type: none"> <li>• CHECK the timing chain and pulley(s). INSTALL new components as necessary. REFER to: <a href="#">Timing Chain</a> (303-01C Engine, Removal and Installation).</li> </ul>
<ul style="list-style-type: none"> <li>• Noisy running or valve train noise</li> </ul>	<ul style="list-style-type: none"> <li>• Valve clearance too large due to faulty valve tappets or worn valve train components.</li> <li>• CHECK and adjust the valve clearances. REFER to: <a href="#">Valve Clearance Adjustment</a> (303-01C Engine, General Procedures).</li> </ul>
<ul style="list-style-type: none"> <li>• Timing chain damaged.</li> </ul>	<ul style="list-style-type: none"> <li>• INSTALL a new timing chain. REFER to: <a href="#">Timing Chain</a> (303-01C Engine, Removal and Installation).</li> </ul>

	<ul style="list-style-type: none"> <li>● Timing chain incorrectly tensioned.</li> </ul>	<ul style="list-style-type: none"> <li>● CHECK the timing chain tensioner. INSTALL a new timing chain tensioner or timing chain as necessary. REFER to: <a href="#">Timing Chain</a> (303-01C Engine, Removal and Installation).</li> </ul>
<ul style="list-style-type: none"> <li>● Noisy running or engine noise</li> </ul>	<ul style="list-style-type: none"> <li>● Engine components</li> <li>● Pistons</li> <li>● Piston rings</li> <li>● Connecting rod big end, main bearing or thrust bearing journals</li> <li>● Connecting rods bent or damaged.</li> </ul>	<ul style="list-style-type: none"> <li>● CHECK the engine components for wear or damage. Make sure that all components are within specification. INSTALL new components as necessary.</li> </ul>

**Engine - Oil Leaks**

**NOTE:** Before installing new gaskets or seals, make sure that the fault is clearly established.

If the oil leak cannot be identified clearly by a visual inspection, carry out an ultraviolet (UV) test:

**Ultraviolet (UV) Testing**

1. Clean the engine and transmission with a suitable cleaning fluid.
2. Pour the UV-test fluid in accordance with the quantity specified by the manufacturer through the oil filler neck into the engine and install the oil filler cap.

 **WARNING: Vehicles with manual transaxle, shift the transaxle into Neutral. Failure to follow this instruction may result in personal injury.**

3. Start the engine and let it run for about five minutes.

4. Switch off the engine.

**NOTE:** *If no leak can be found, road test the vehicle under various loads and check the engine for leaks again.*

5. Check the engine for oil leaks using a suitable UV lamp.
6. Rectify any leaks found and check the engine for oil leaks.

## Measure the Compression Pressure

 **WARNING:** Do not smoke or carry lighted tobacco or open flame of any type when working on or near any fuel related components. Highly flammable mixtures are always present and can ignite. Failure to follow these instructions may result in personal injury.

**NOTE:** *The powertrain control module (PCM) receives an error message when the fuel pump relay is removed or electrical components are disconnected. This error message must be deleted from the fault memory using the Ford diagnostic equipment after completing the compression test.*

**NOTE:** *Valve clearance must be set correctly before carrying out a compression test. Make sure that the engine is at the normal operating temperature.*

**NOTE:** *The varying design of compression checking devices and fluctuating starter motor speeds normally only allows for a comparison to be made of the compression pressures in all cylinders.*

**NOTE:** *The readings from the compression pressure check should be used as an indication of cylinder balance. If one or more of the readings is significantly lower than the others, investigate that particular cylinder for concerns.*

1. Open the battery junction box (BJB) and remove fuse 49 - fuel pump relay.
2. Start and run the engine at idle speed until the engine stops.
3. Remove the ignition coil-on-plugs.  
REFER to: Ignition Coil-On-Plug (303-07A) .
4. Using the special tool, remove the spark plugs.

**NOTE:** *Operate the starter motor with wide open throttle until the reading on the compression tester stops rising.*

5. Carry out the measurement in accordance with the instructions supplied with the measuring device on every cylinder using a suitable compression pressure recorder with a suitable adapter.

6. Using the special tool, install the spark plugs and tighten to 15 Nm.
7. Install the ignition coil-on-plugs.  
REFER to: Ignition Coil-On-Plug (303-07A) .
8. Install fuse 49 (fuel pump relay) and close the BJB.
9. Using the Ford diagnostic equipment, clear the DTC(s) from the PCM.

## Measure the Oil Pressure

**NOTE:** *The oil pressure depends on various factors (engine speed, oil temperature, oil viscosity, extent of oil filter contamination).*

**NOTE:** *Measure the oil pressure at the specified engine speed.*

1. Raise and support the vehicle.  
REFER to: Jacking and Lifting (100-02) .
2. Disconnect the oil pressure switch electrical connector from the oil pressure switch.
3. Remove the oil pressure switch.
4. Attach the oil pressure gauge with the oil pressure gauge connector to the oil pressure switch bore, and position it to allow reading from above.
5. Lower the vehicle.
6. **NOTE:** *Measure the oil pressure at an oil temperature of 80°C.*

**NOTE:** *Oil pressure at 2000 rpm: 2.0 bar - 4.1 bar.*

Measure the oil pressure.

7. Raise and support the vehicle.  
REFER to: Jacking and Lifting (100-02) .
8. Detach the oil pressure gauge and connector from the oil pressure switch bore.
9. Coat the oil pressure switch with adhesive (Adhesive - Loctite 243) (WSK-M2G349-A7) .
10. Install the oil pressure switch.
11. Connect the oil pressure switch electrical connector to the oil pressure switch.

12. Lower the vehicle.

## **Valve Train Analysis**

The following component tests are used to diagnose valve train concerns.

### **Valve Train Analysis - Engine Off, Valve Cover Removed**

Check for damaged or severely worn parts and correct assembly. Make sure that correct parts are used with the static engine analysis as follows.

### **Valve Train Analysis - Camshafts and Valve Tappets**

- Check for broken or damaged parts.
- Check for loose mounting bolts on camshaft caps.
- Check for worn or damaged valve tappets.

### **Valve Train Analysis - Valve Springs, Valve Tappets Removed**

- Check for broken or damaged parts.

### **Valve Train Analysis - Valve Spring Retainer and Valve Spring Retainer Keys, Valve Tappets Removed**

- Check for correct seating of the valve spring retainer key on the valve stem and in valve spring retainer.
- Check for correct seating on the valve stem.

### **Valve Train Analysis - Valves and Cylinder Head, Valve Tappets Removed**

- Check for blocked oil drain back holes.
- Check for worn or damaged valve tips.
- Check for missing or damaged valve stem seals or guide-mounted valve stem seal.
- Check for missing or worn valve spring seats.

### **Valve Train Analysis - Camshaft Lobe Lift**

Check the lift of each camshaft lobe in consecutive order and make a note of the readings.

1. Remove the spark plugs.  
REFER to: Spark Plugs (303-07A) .
2. Install the Dial Indicator Gauge (100-002 or 205-069) with Holding Fixture (205-070) so the rounded tip of the dial indicator is on top of the camshaft lobe and on the same plane as the

valve tappet.

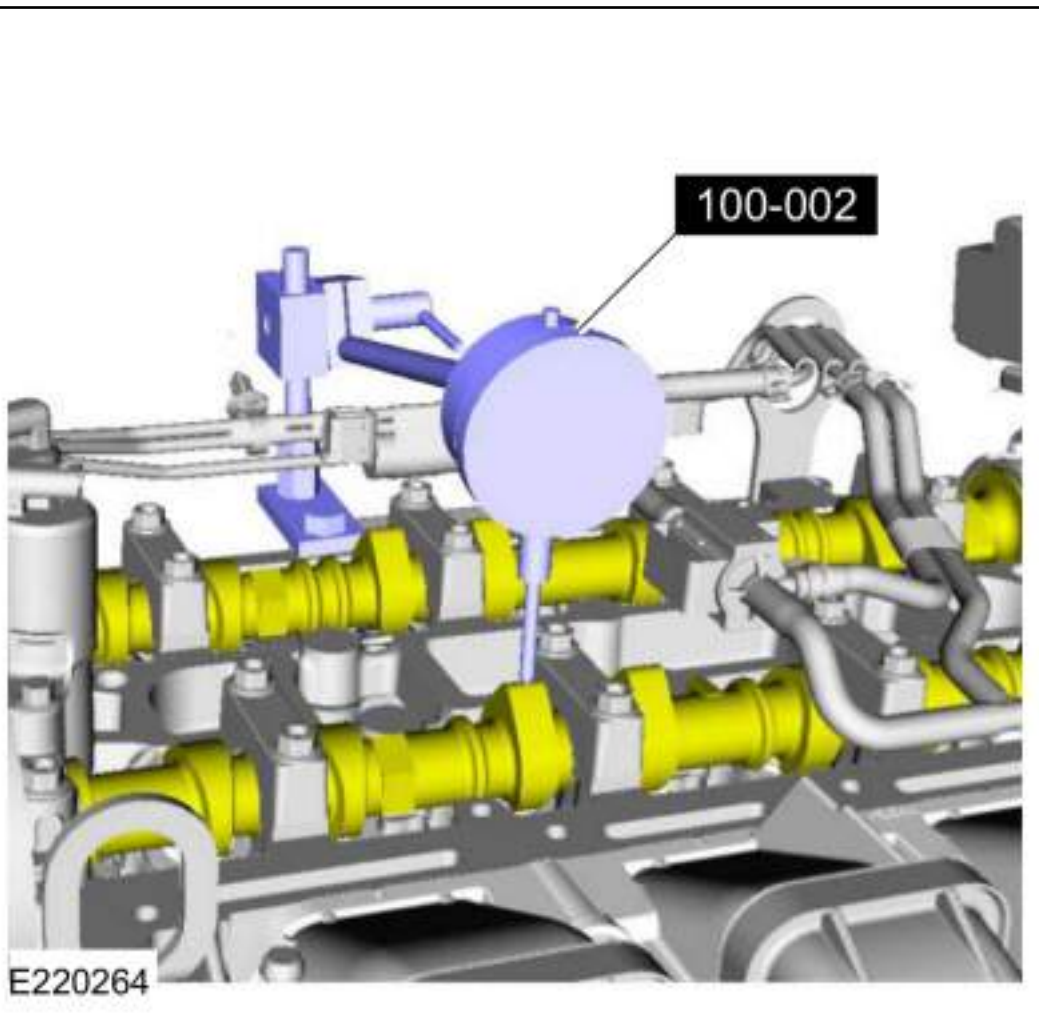

3. Rotate the crankshaft using a breaker bar and socket attached to the crankshaft pulley retainer bolt. Rotate the crankshaft until the base circle of the camshaft lobe is reached.
4. Zero the dial indicator. Continue to rotate the crankshaft until the high-lift point of the camshaft lobe is in the fully raised position (highest indicator reading).
5. To check the accuracy of the original dial indicator reading, continue to rotate crankshaft until the base circle is reached. The indicator reading should be zero. If zero reading is not obtained, repeat Steps 2 through 5.
6. If the lift on any lobe is below specified service limits, install a new camshaft and valve tappets.
7. Install the spark plugs.  
REFER to: Spark Plugs (303-07A) .



# Engine

Base Part Number: Base Part Number: 6L084

## Special Tool(s) / General Equipment

 17063	100-010 Remover, O-Ring Seal
 205080	205-080 Installer, Differential Bearing
 21143	303-293 Remover, Crankshaft Seal
 ES21202	303-499 Socket, Spark Plug
Fluid Container	
2 mm Punch	

1.

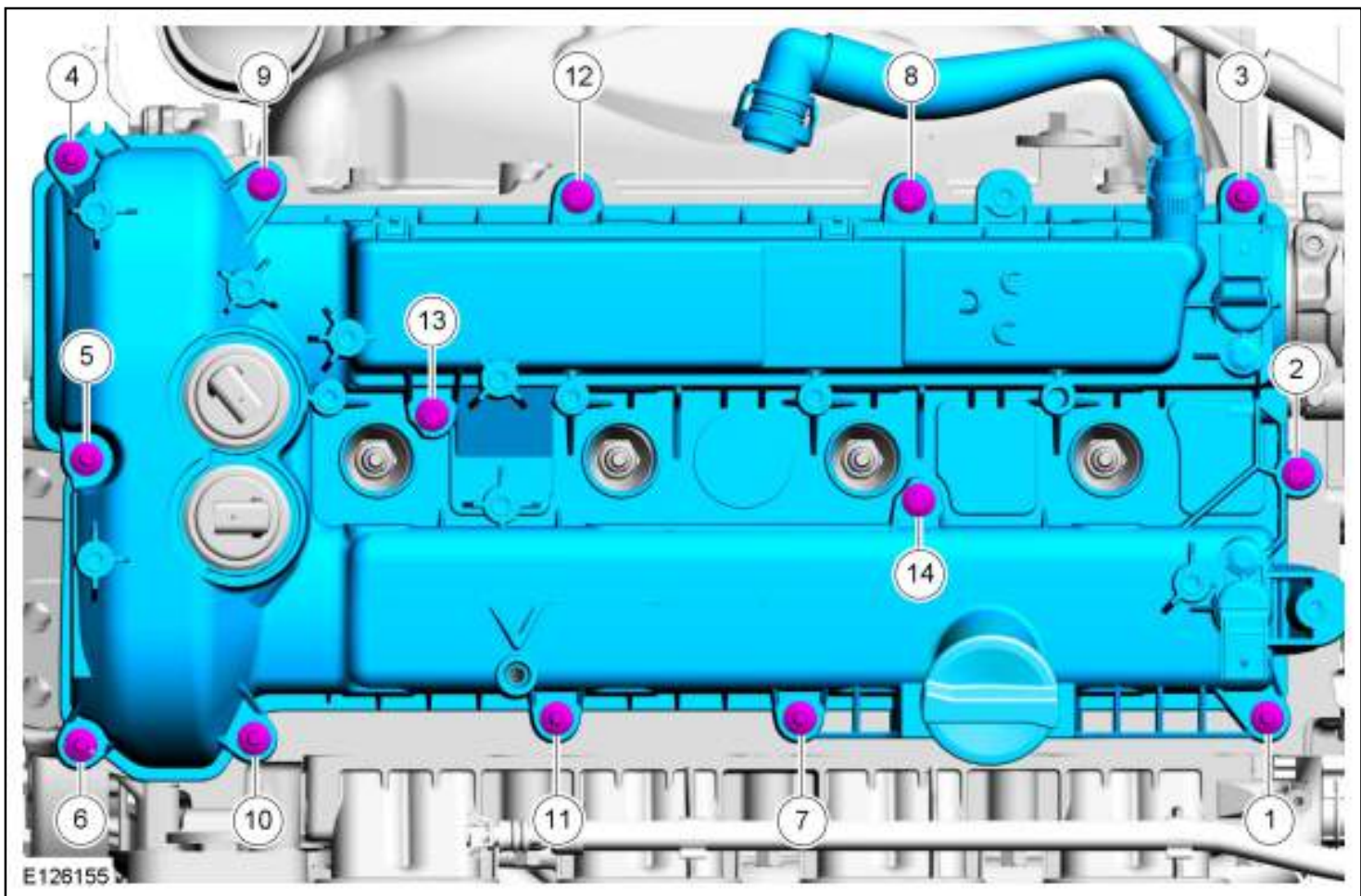

2. **NOTE:** *The gaskets are to be reused unless damaged.*

Use Special Service Tool: 205-080 Installer, Differential Bearing.

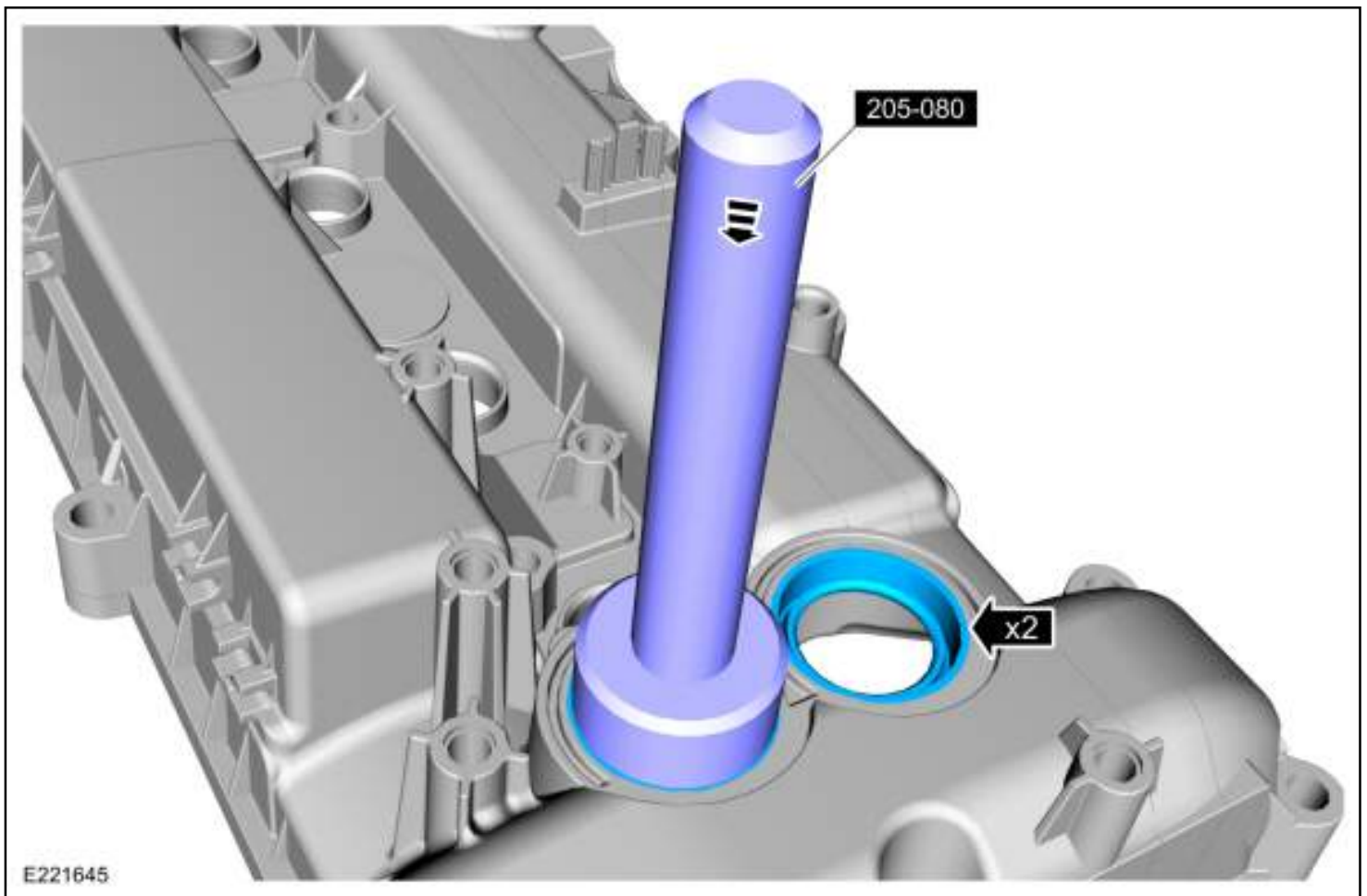

3. Use Special Service Tool: 303-499 Socket, Spark Plug.

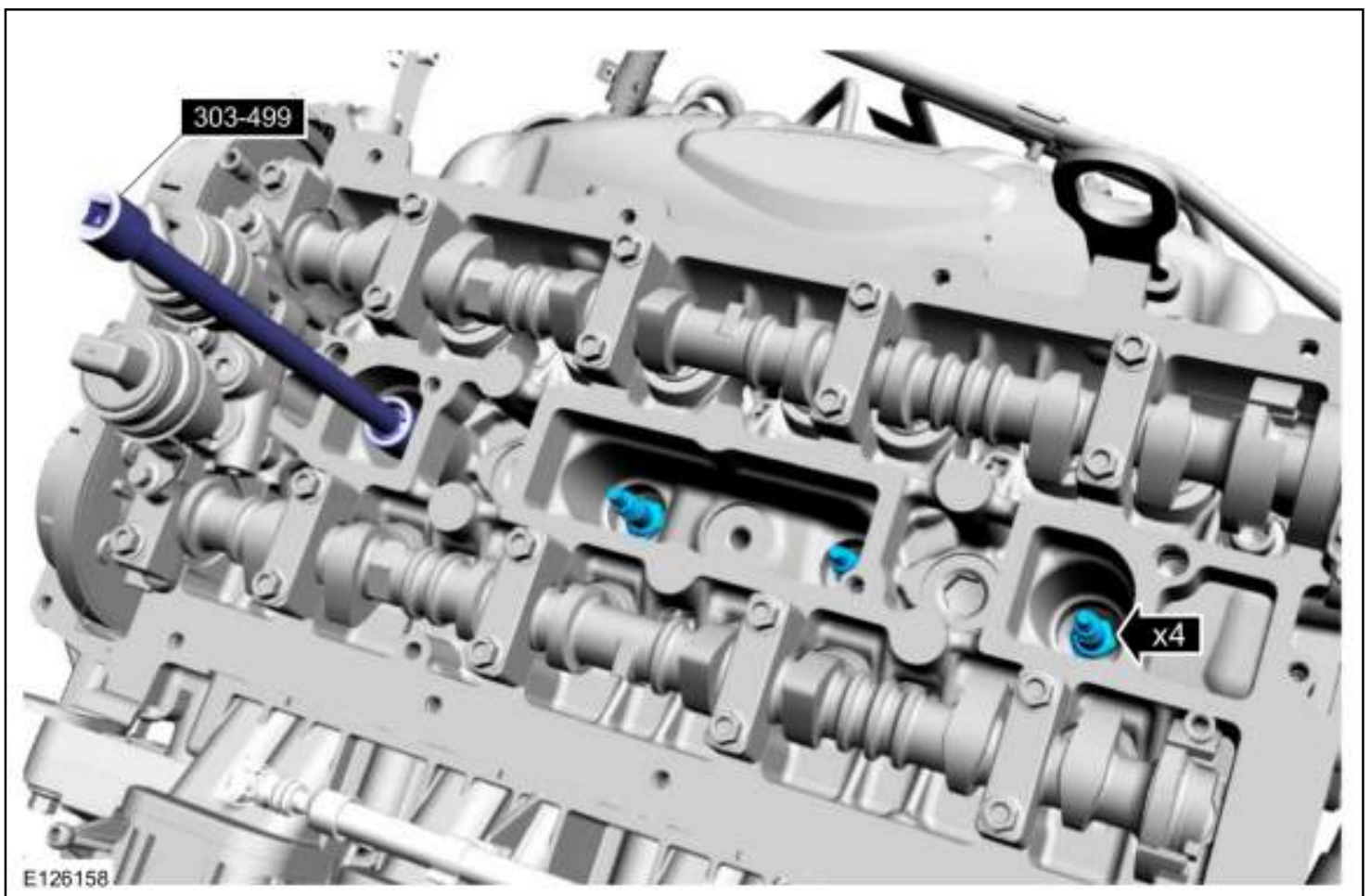

4.

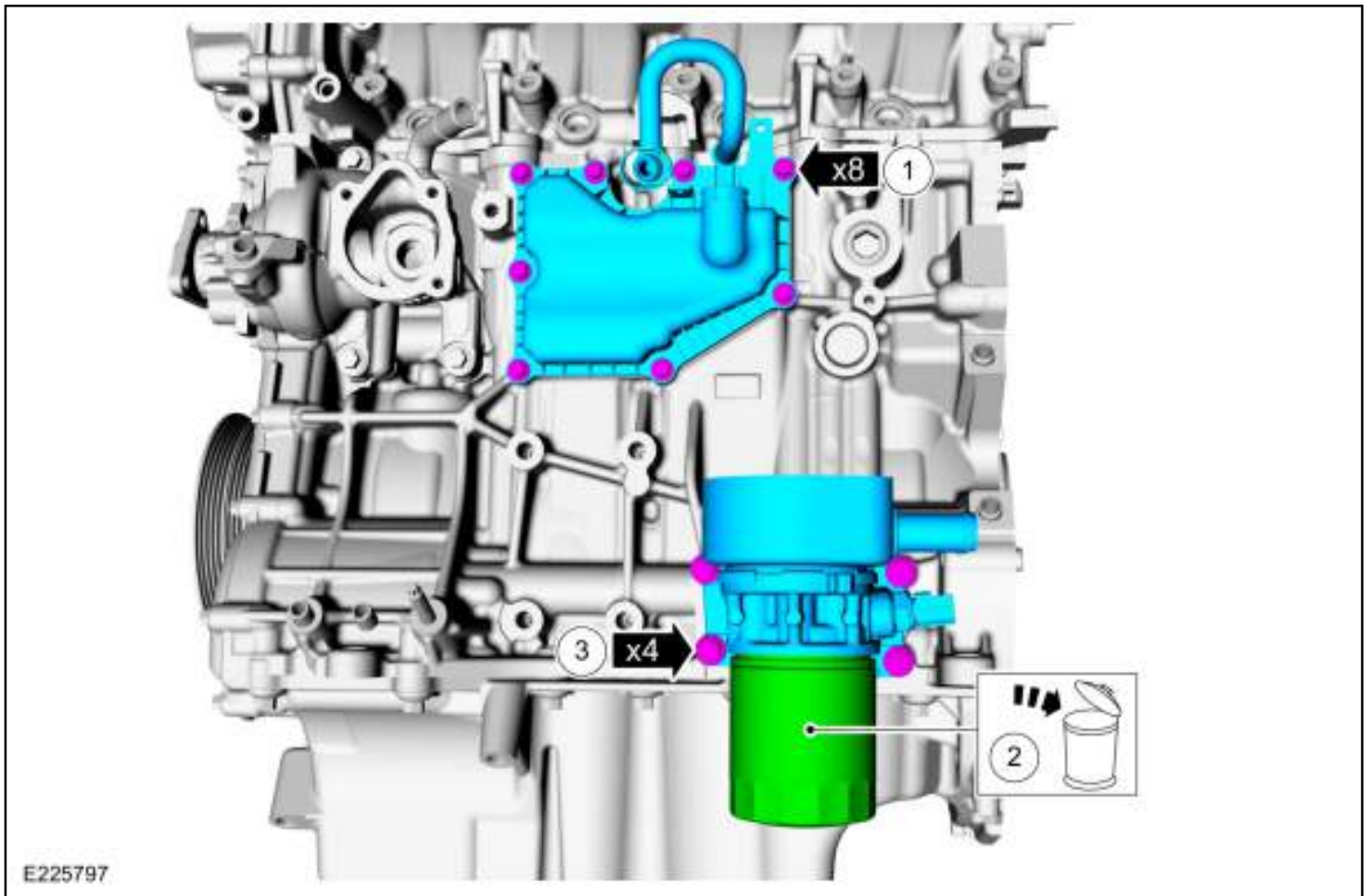

5.

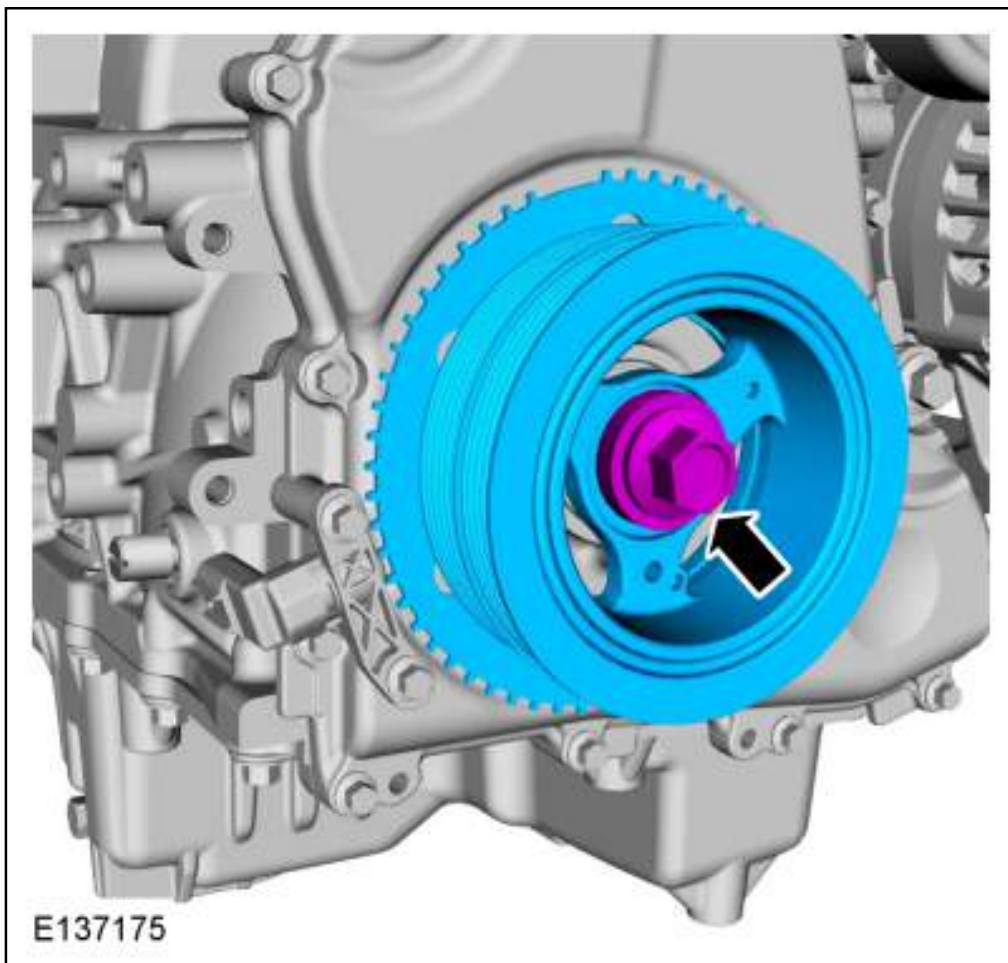

6. Use Special Service Tool: 303-293 Remover, Crankshaft Seal.

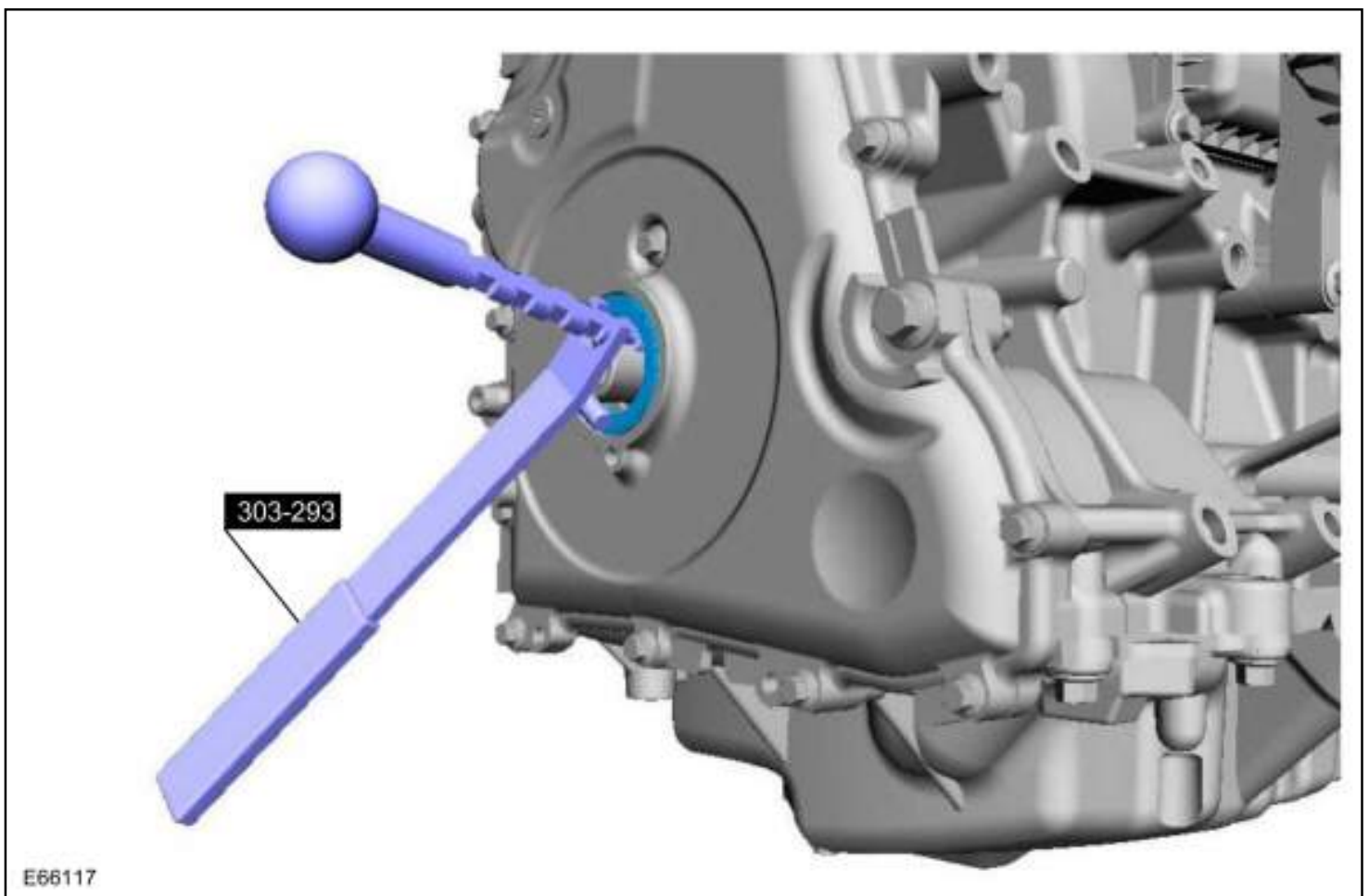

7. **NOTE:** *Discard the friction washer.*

If equipped.

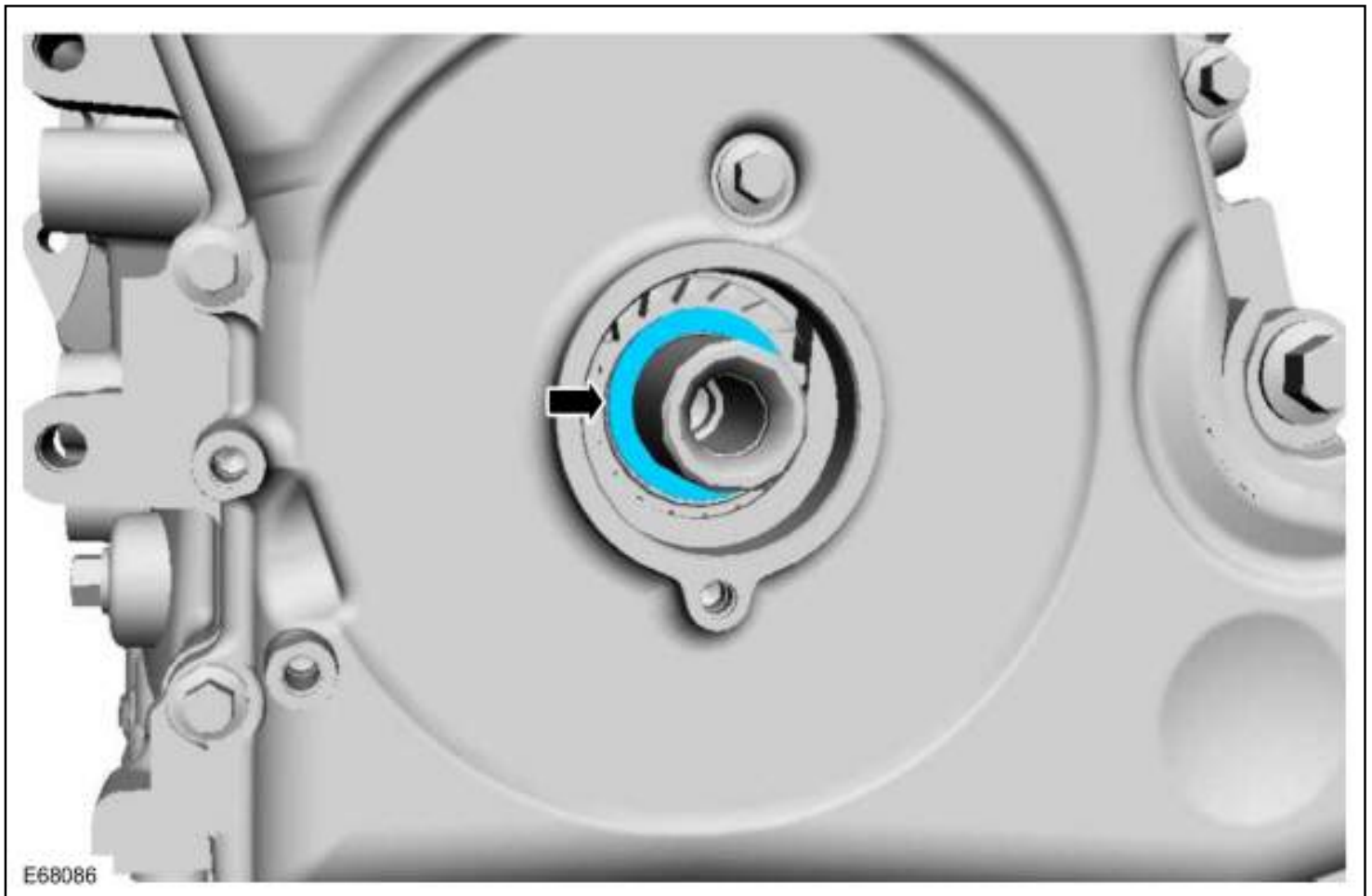

8.

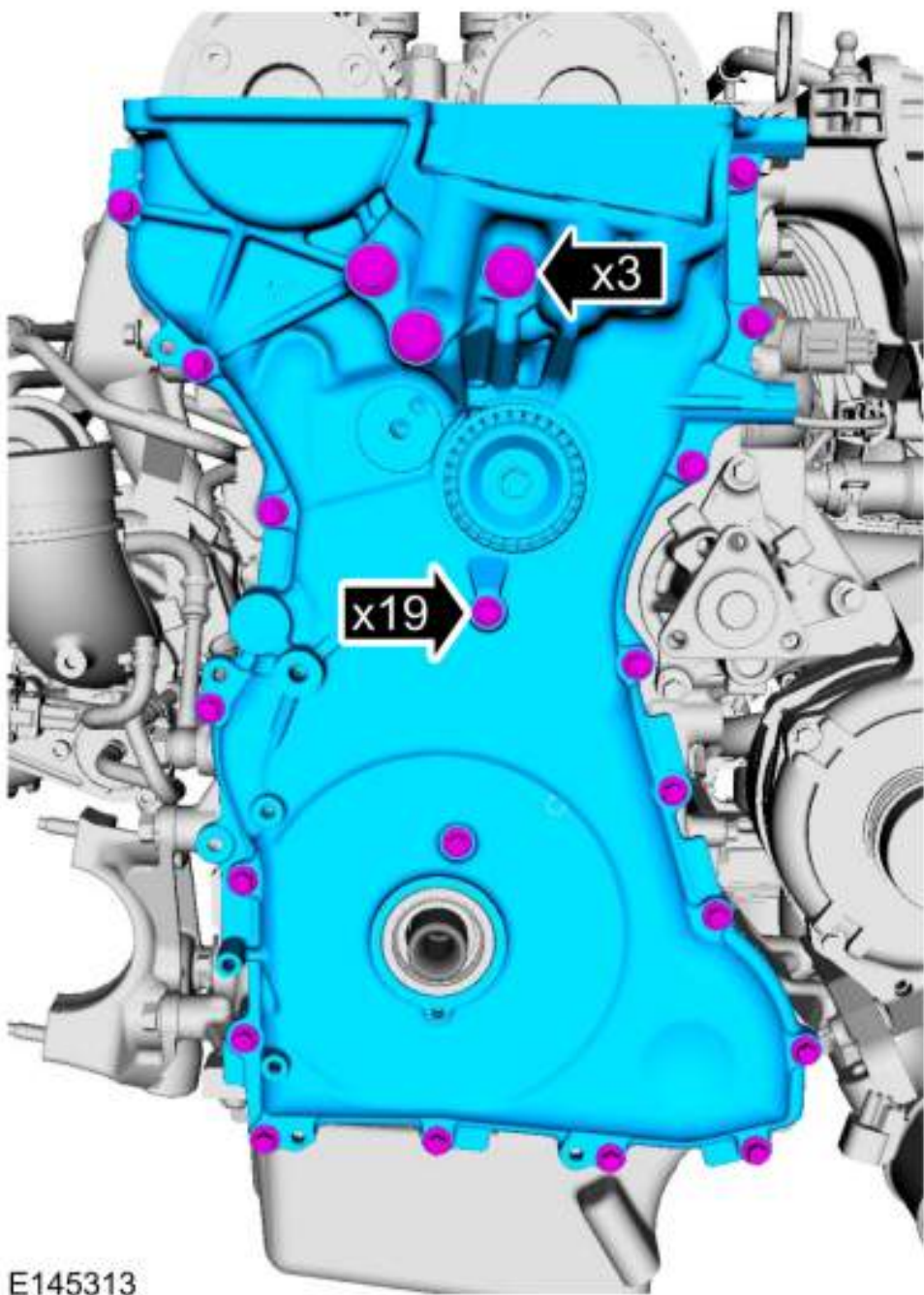

E145313



9. Install Special Service Tool: 100-010 Remover, O-Ring Seal.  
Use the General Equipment: 2 mm Punch

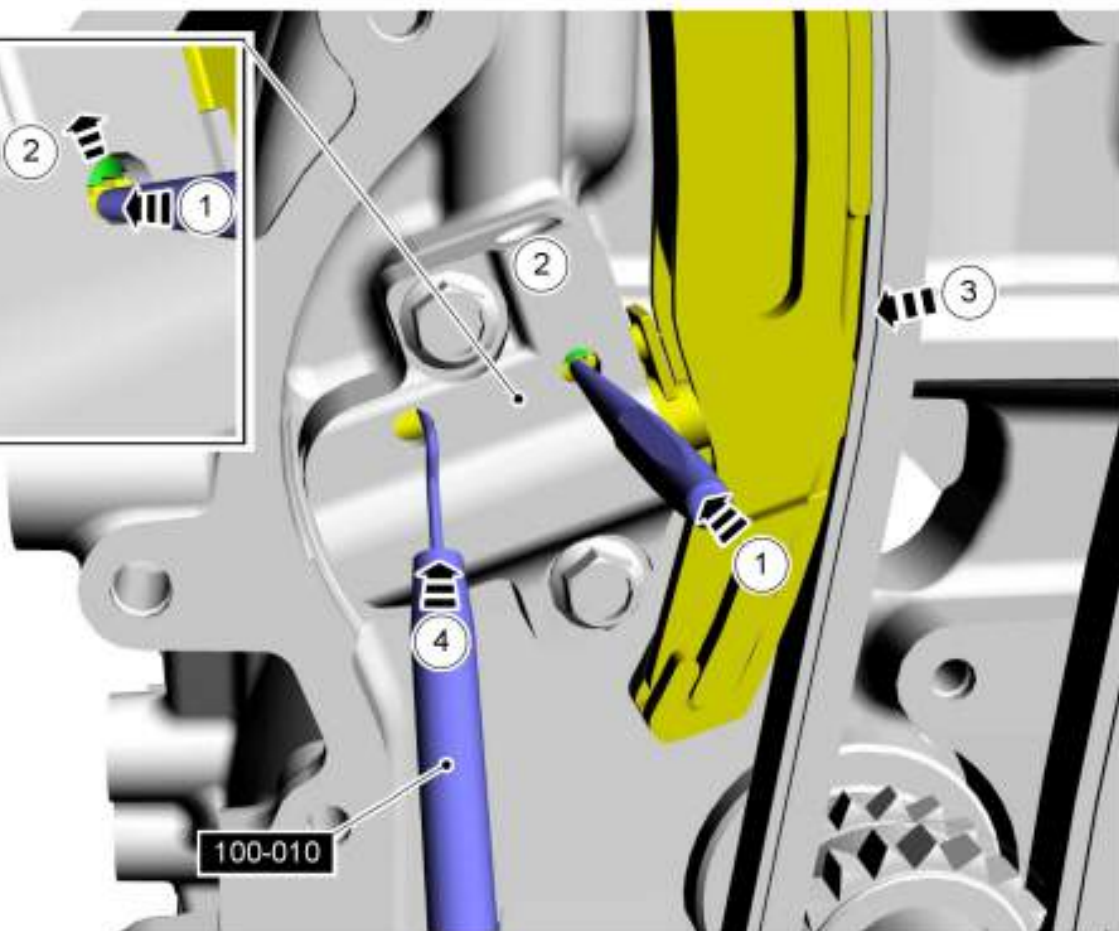
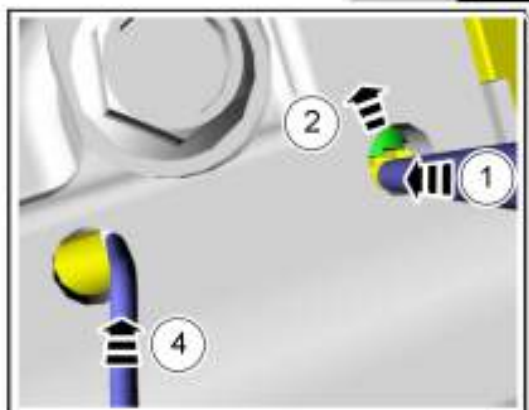

E136839

10. **NOTICE:** Use an open-ended wrench to prevent the component from turning.

**NOTE:** Note the position of the components before removal.

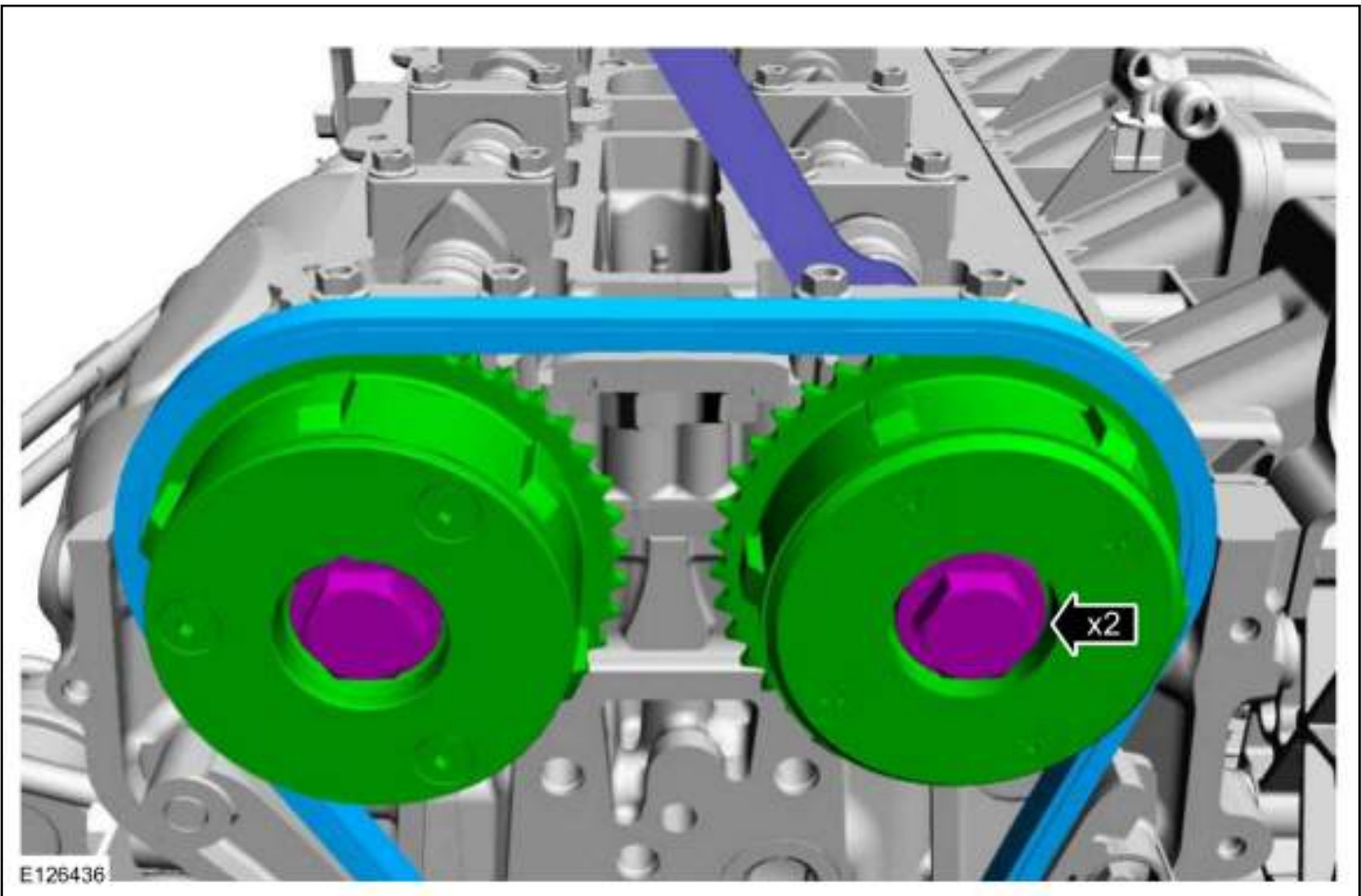

11.

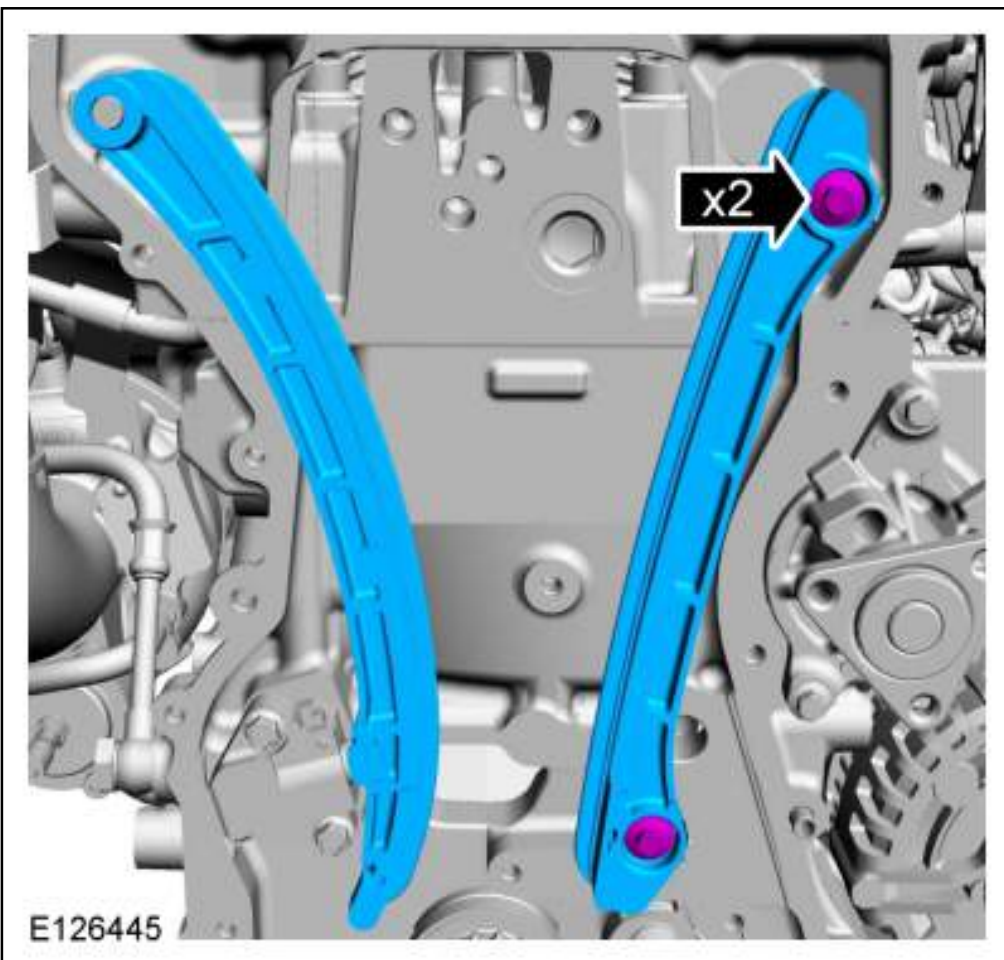

12.  **WARNING:** The tensioner is under spring tension. Be careful when handling the tensioner. Failure to follow this instruction may result in personal injury.

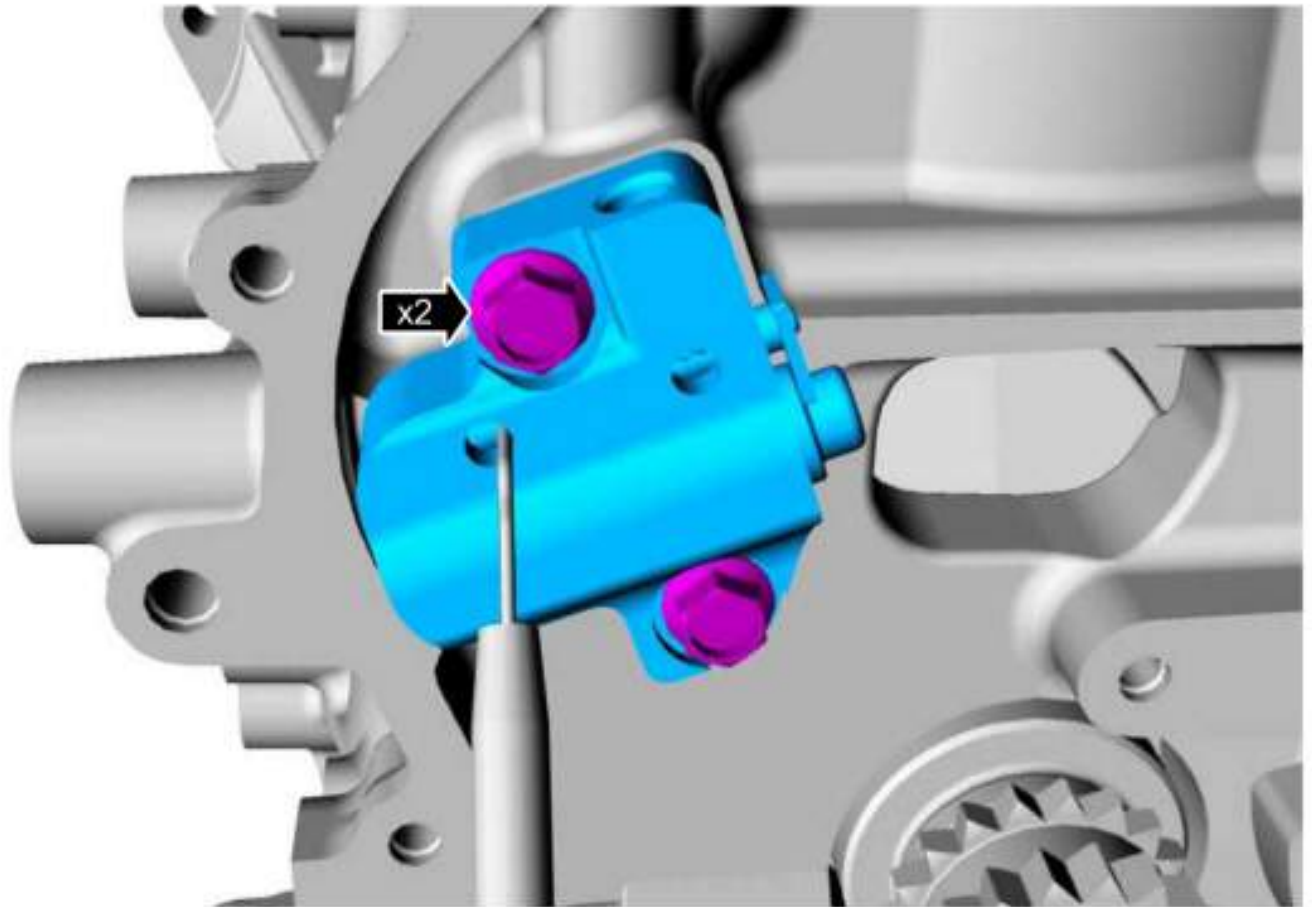

13. **NOTICE:** Note the position of the components before removal.

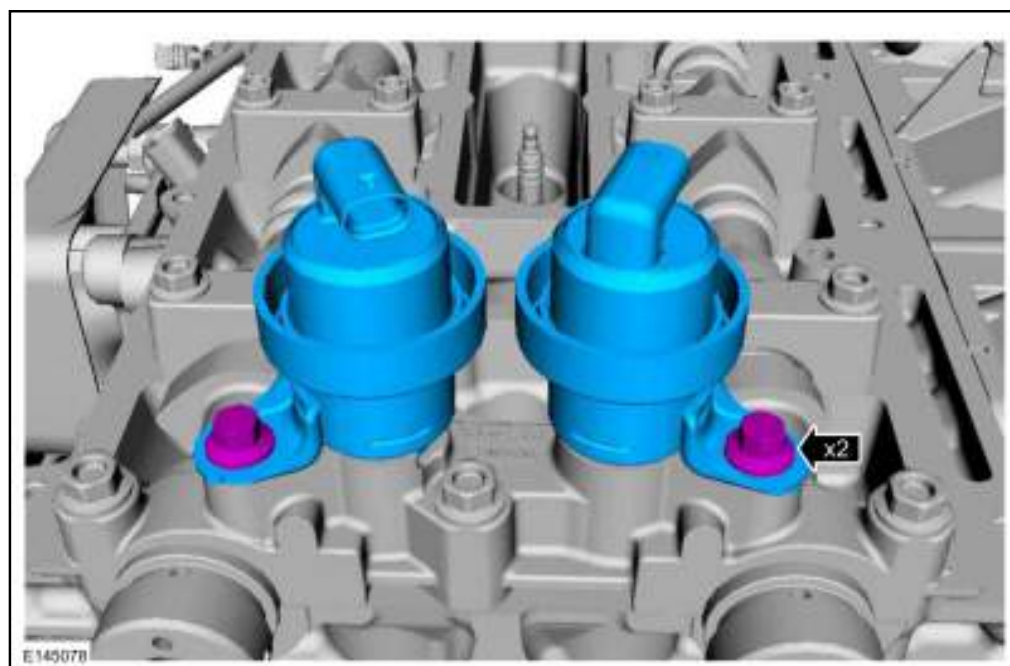

14. Loosen each bolt 2 turns at a time until all bolts are removed.

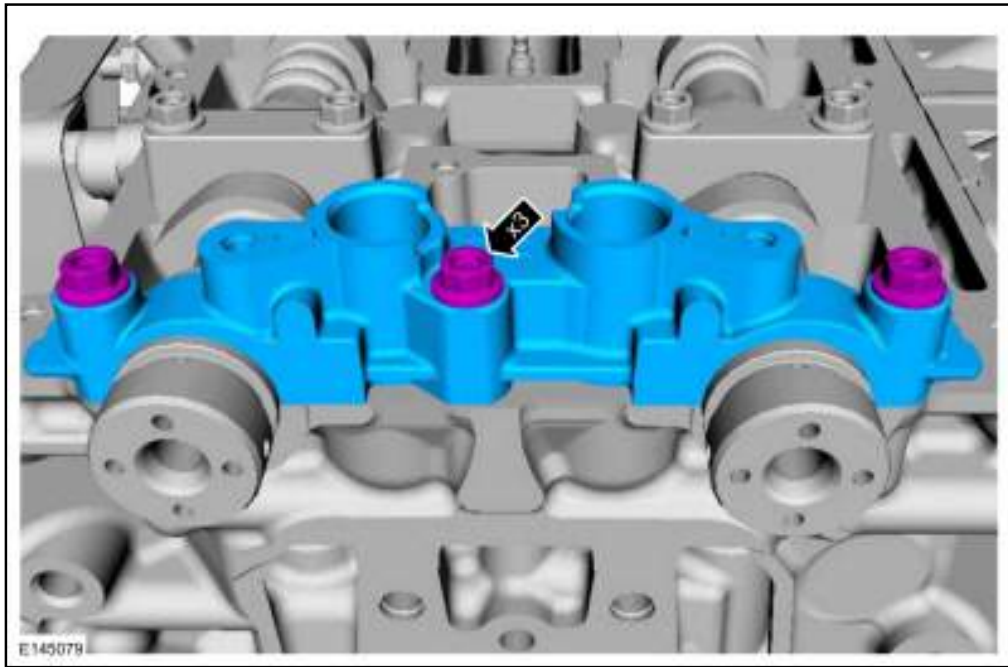

15.

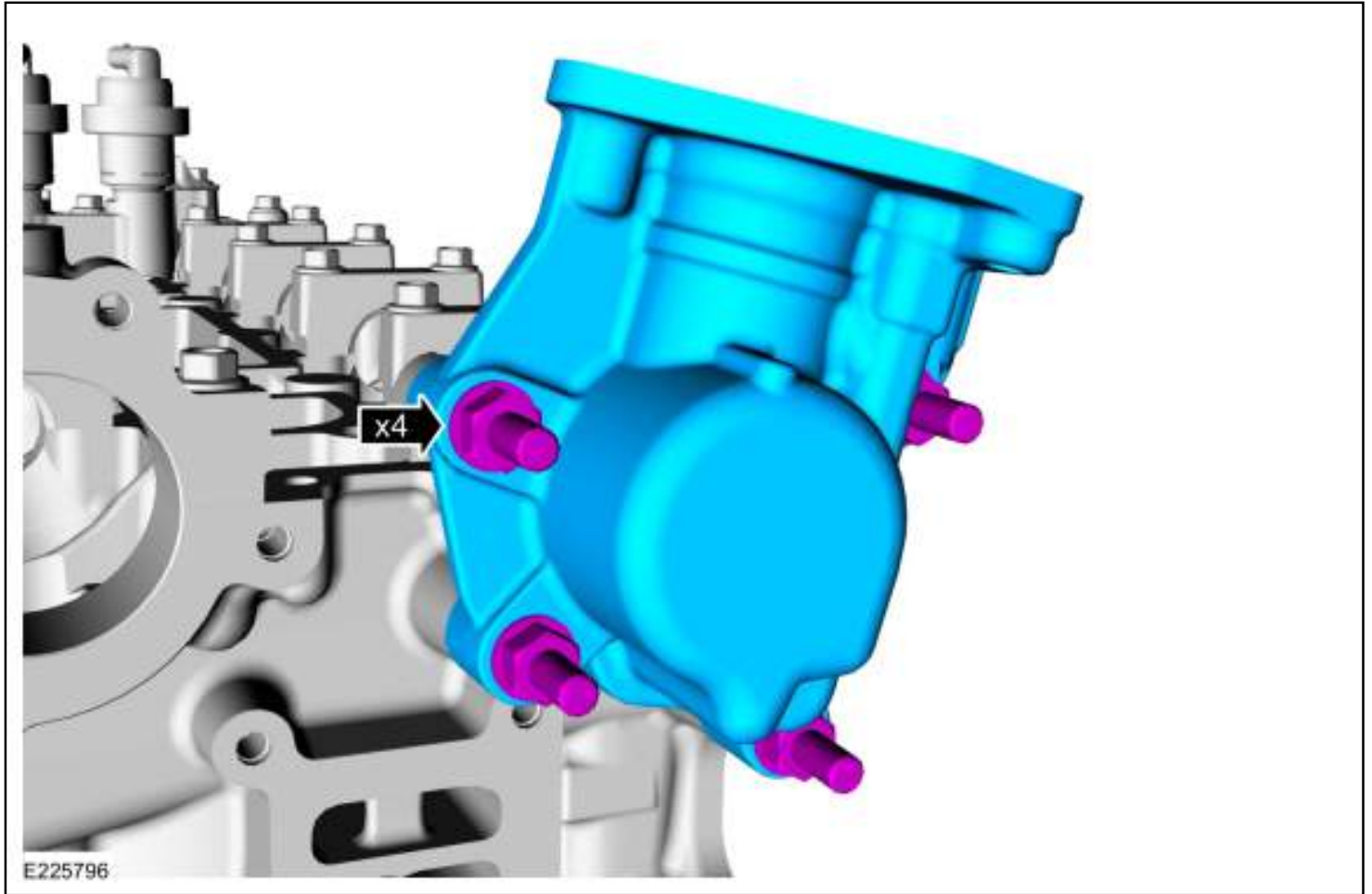

16.

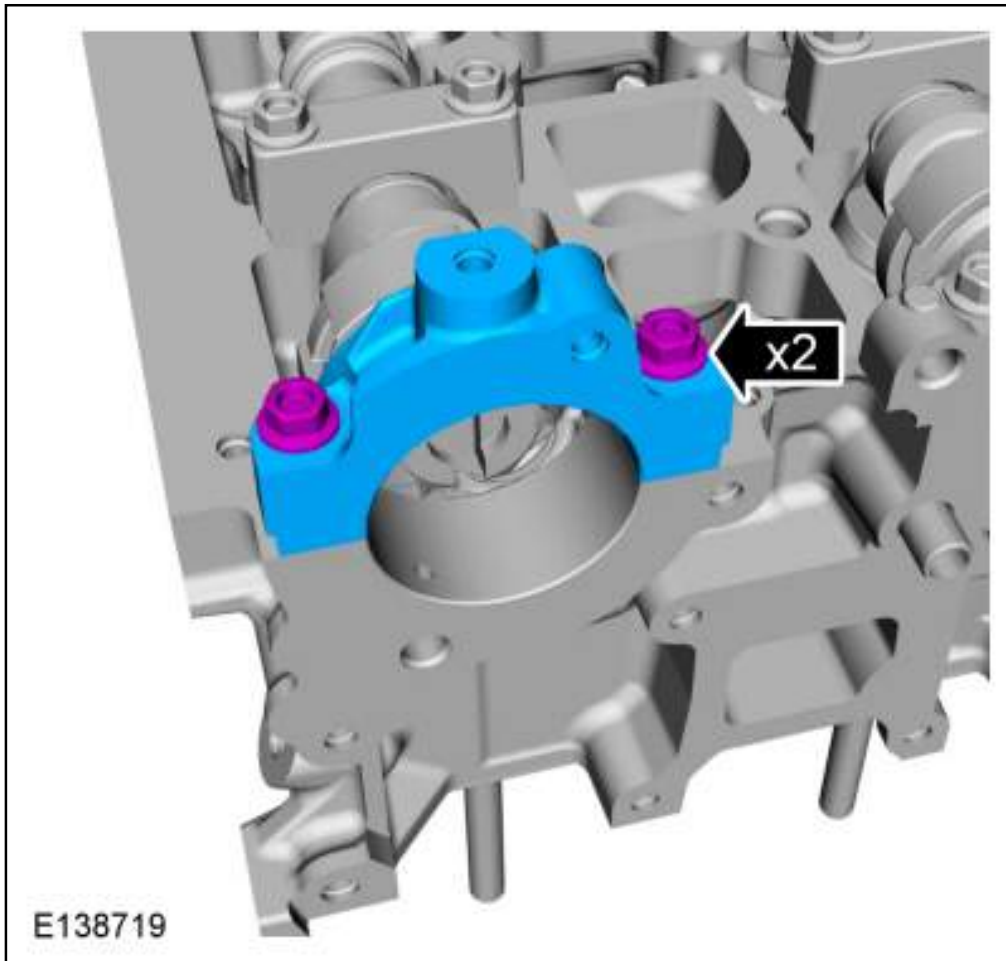

17. **NOTICE:** Use an open-ended wrench to prevent the component from turning.

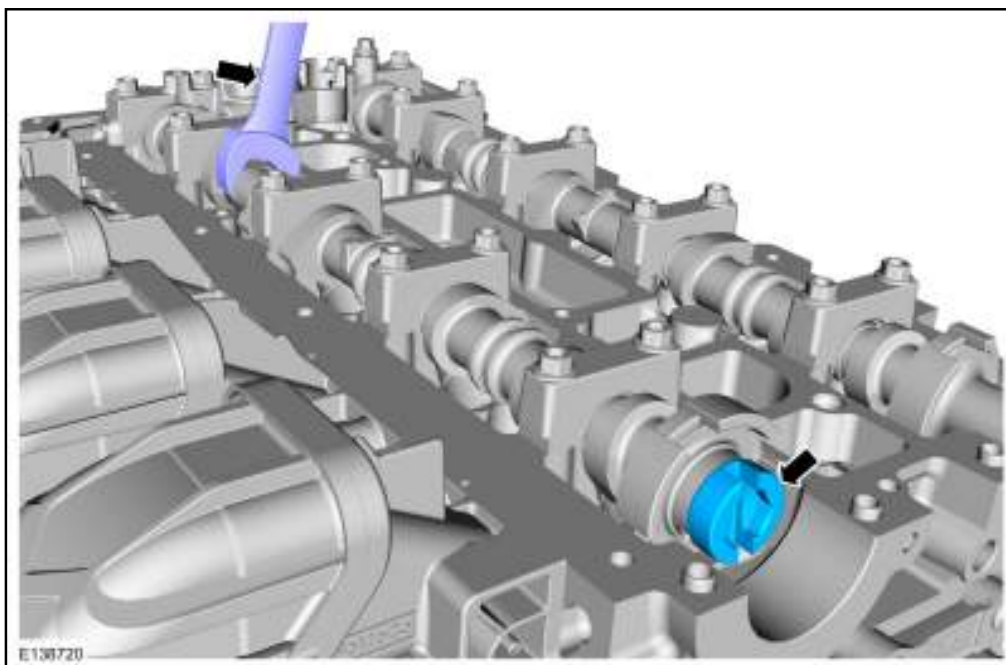

18. **NOTICE:** Note the position of the components before removal.

Loosen each bolt 2 turns at a time until all bolts are removed.

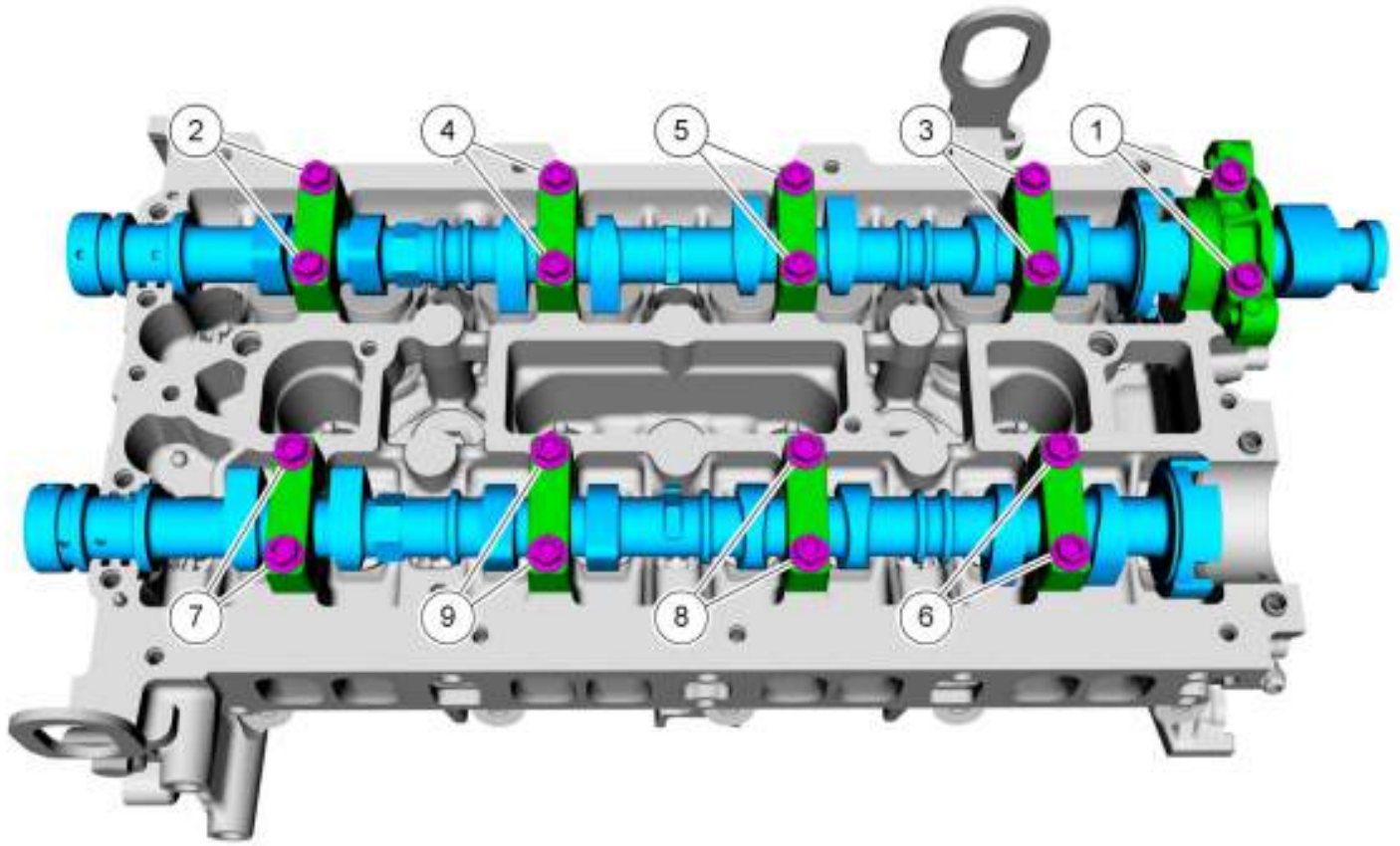

E138713

19. **NOTICE:** Note the position of the components before removal.

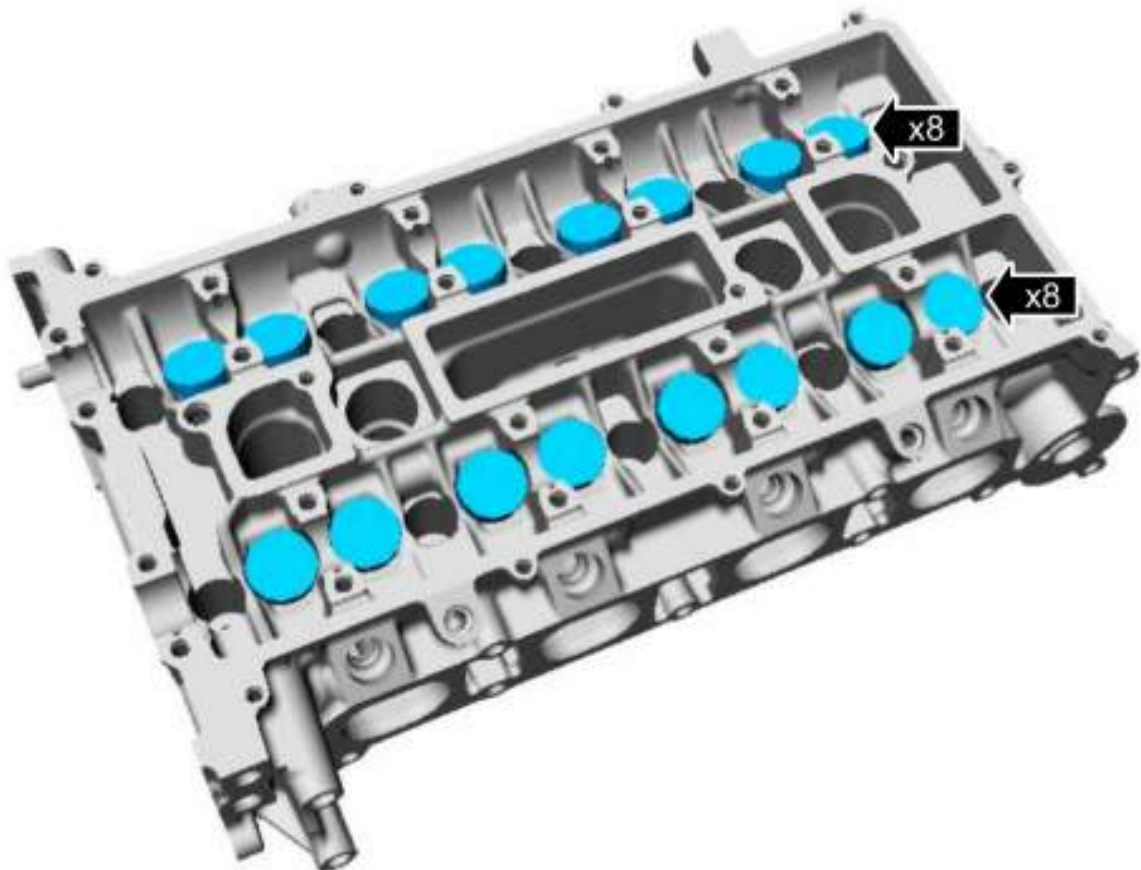

E66111

20.

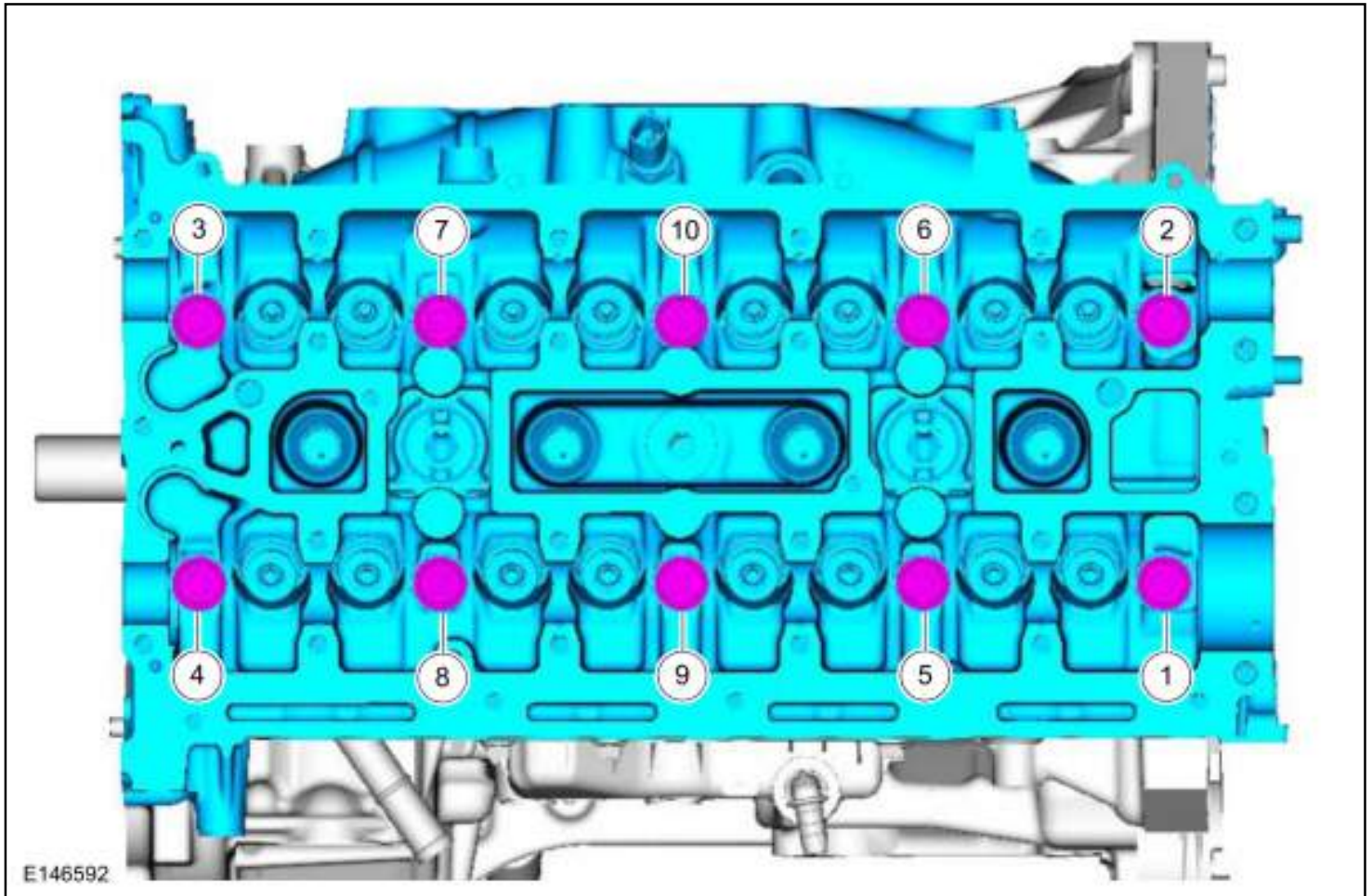

21. **NOTE:** *Be prepared to collect escaping fluid.*

**NOTE:** *The oil drain plug with O-ring seal is to be reused unless damaged.*

Use the General Equipment: Fluid Container  
Torque: 21 lb.ft (28 Nm)

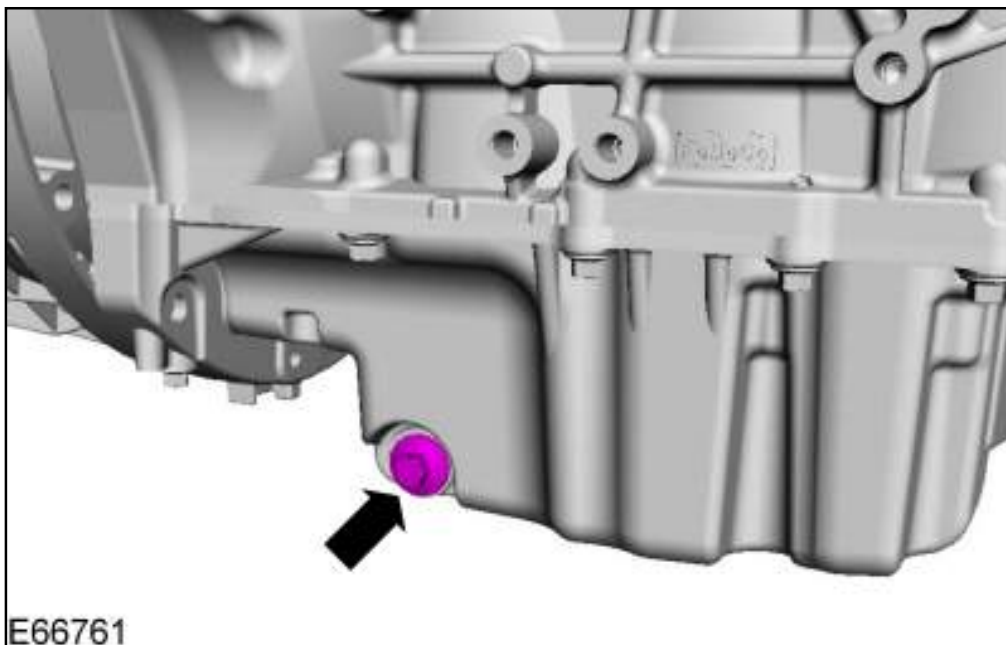

22.

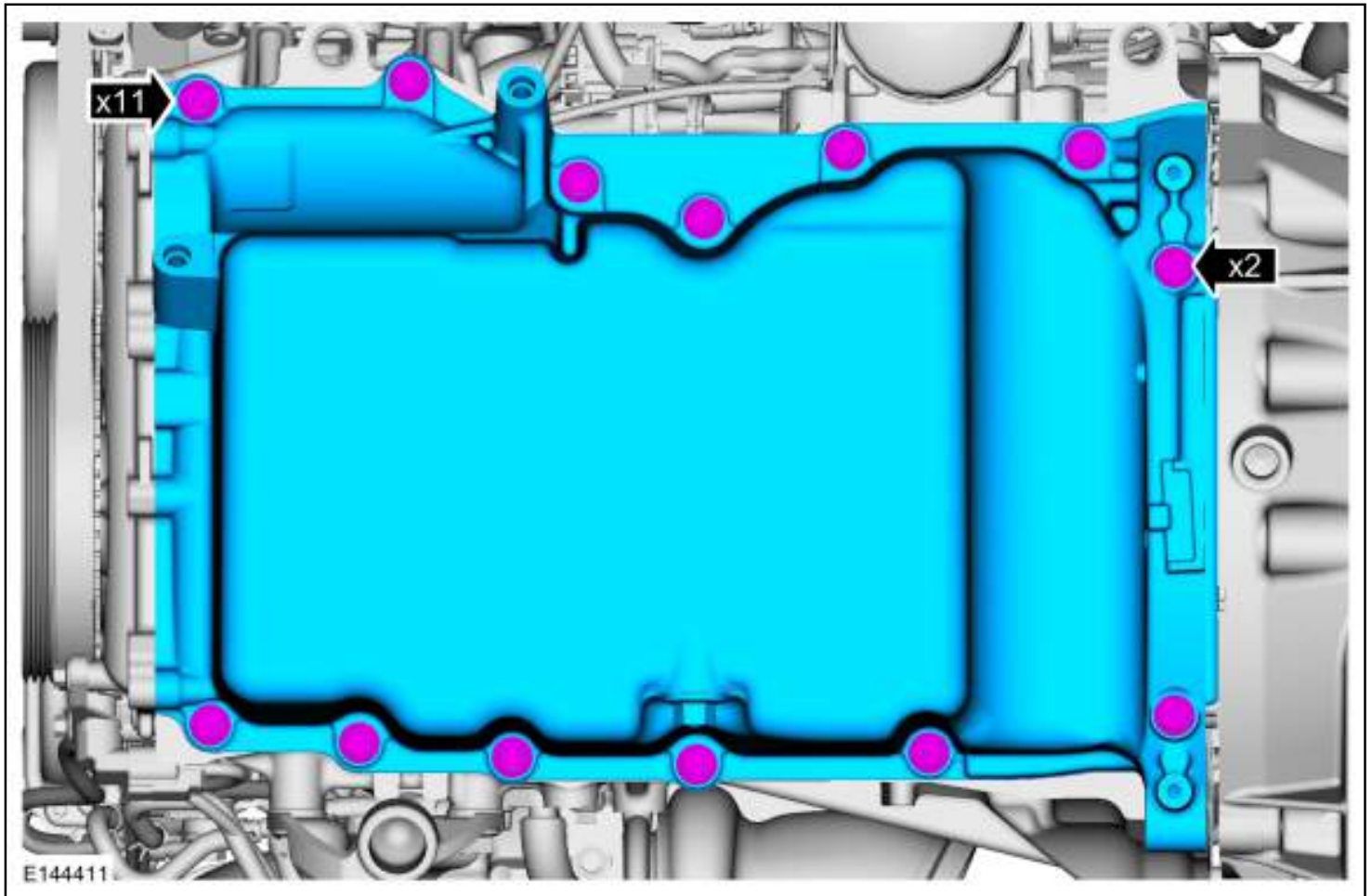

23.  **WARNING:** The tensioner is under spring tension. Be careful when handling the tensioner. Failure to follow this instruction may result in personal injury.

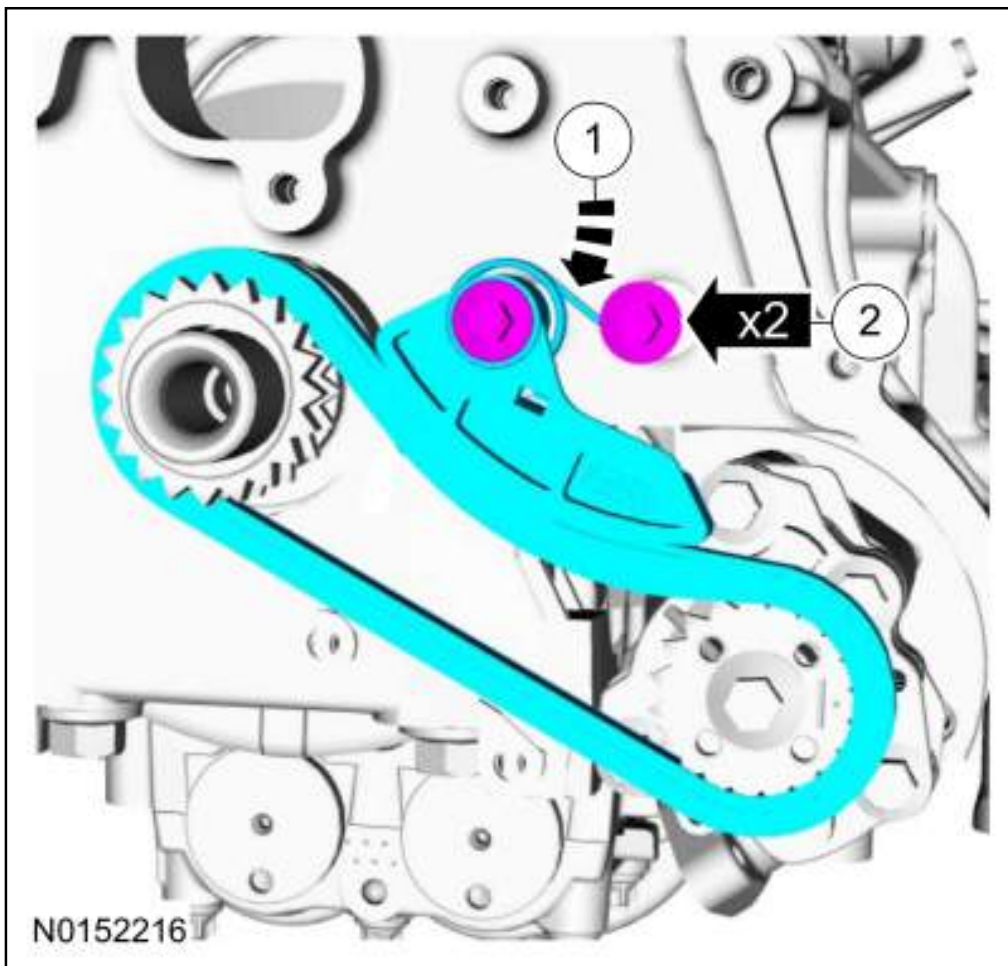

24.

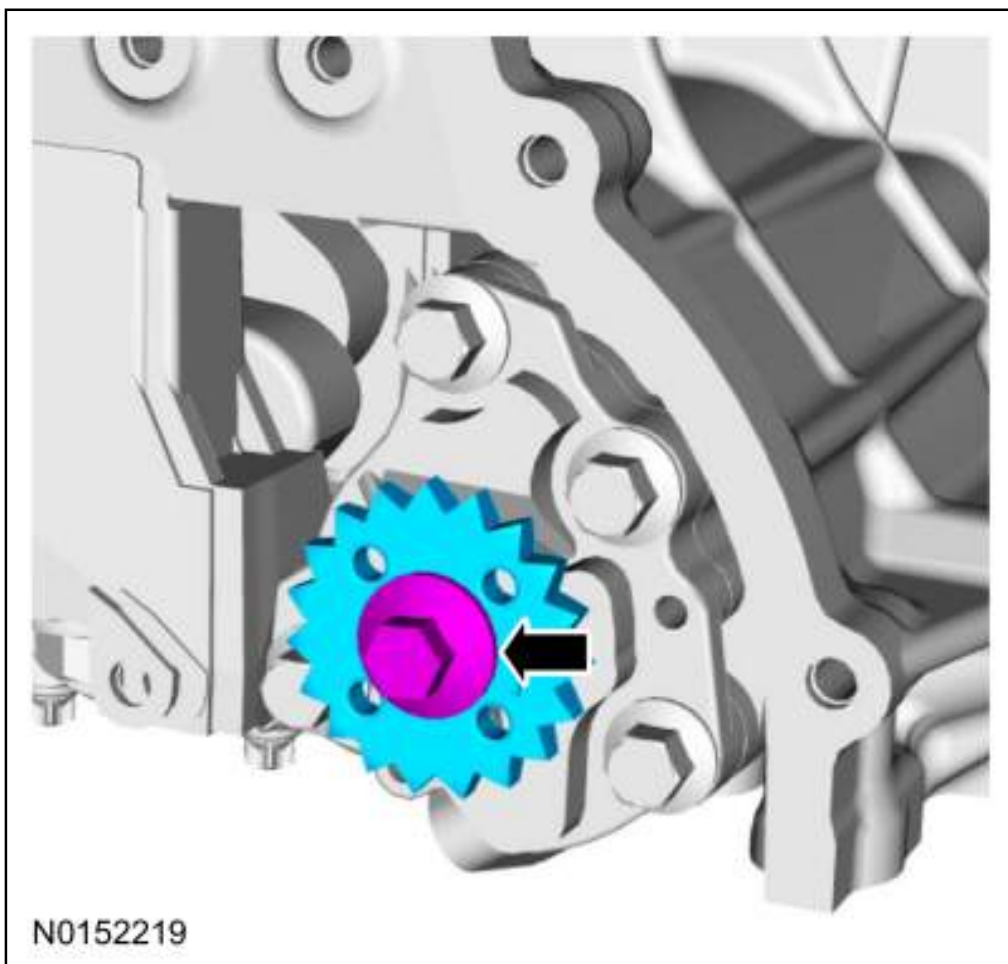

25.

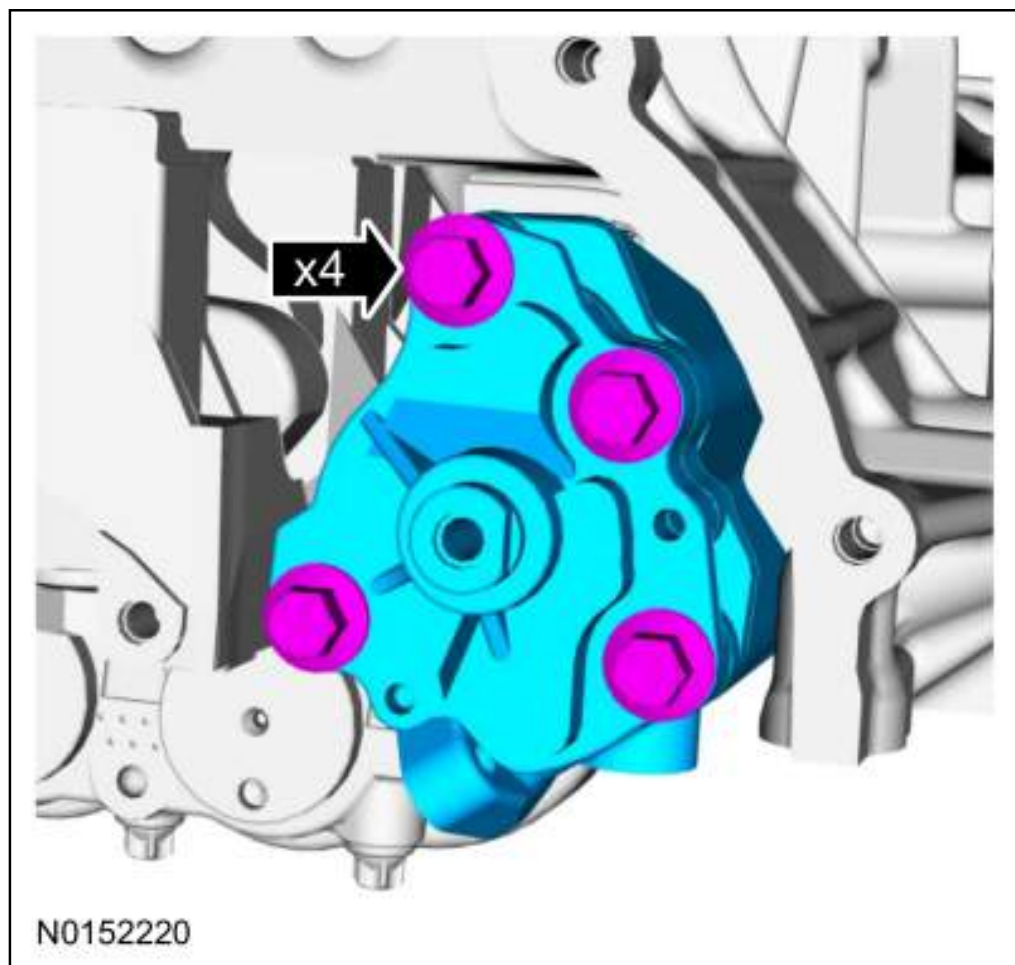

26. **NOTE:** *Discard the friction washer.*

If equipped.

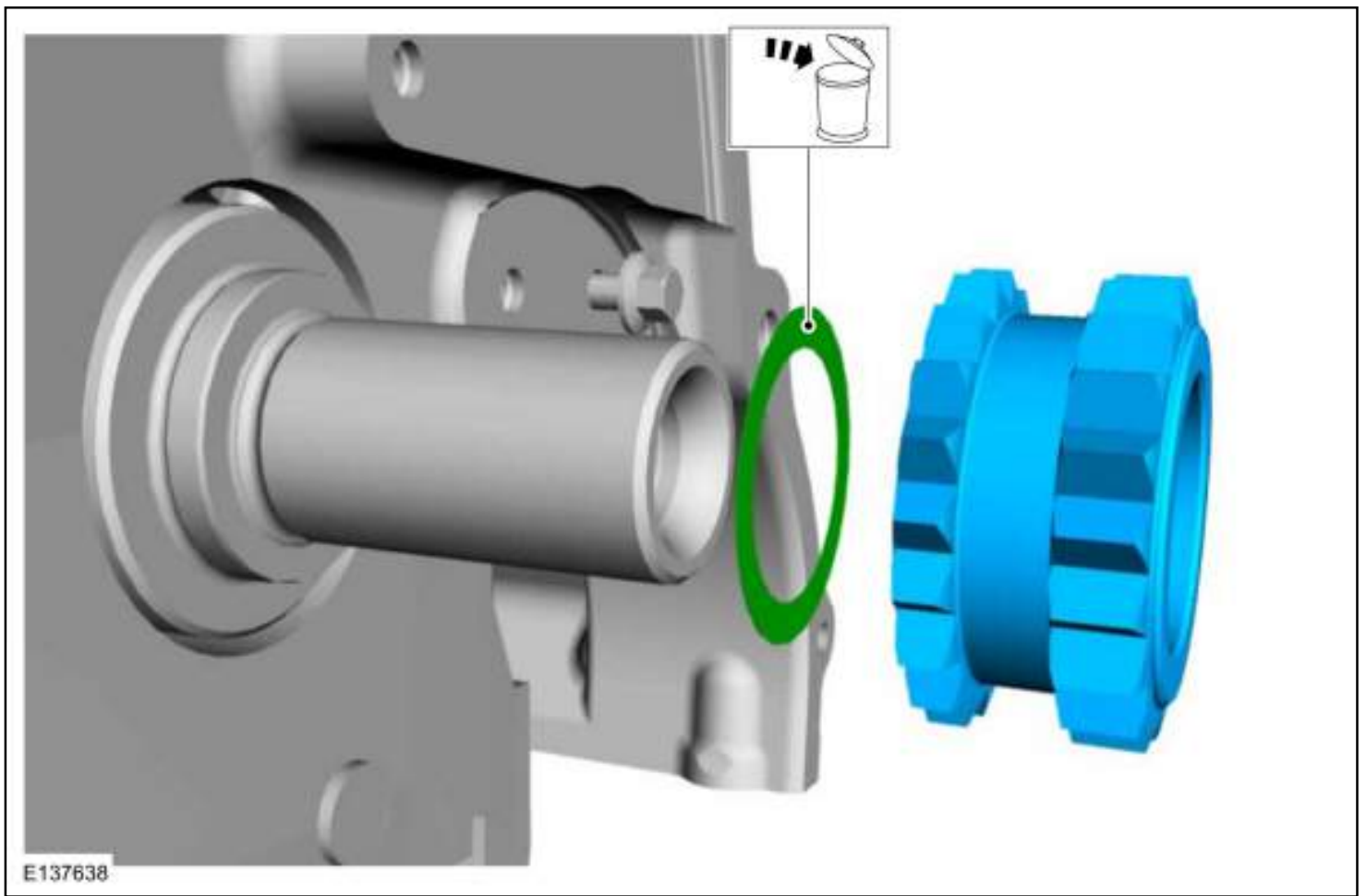

27.

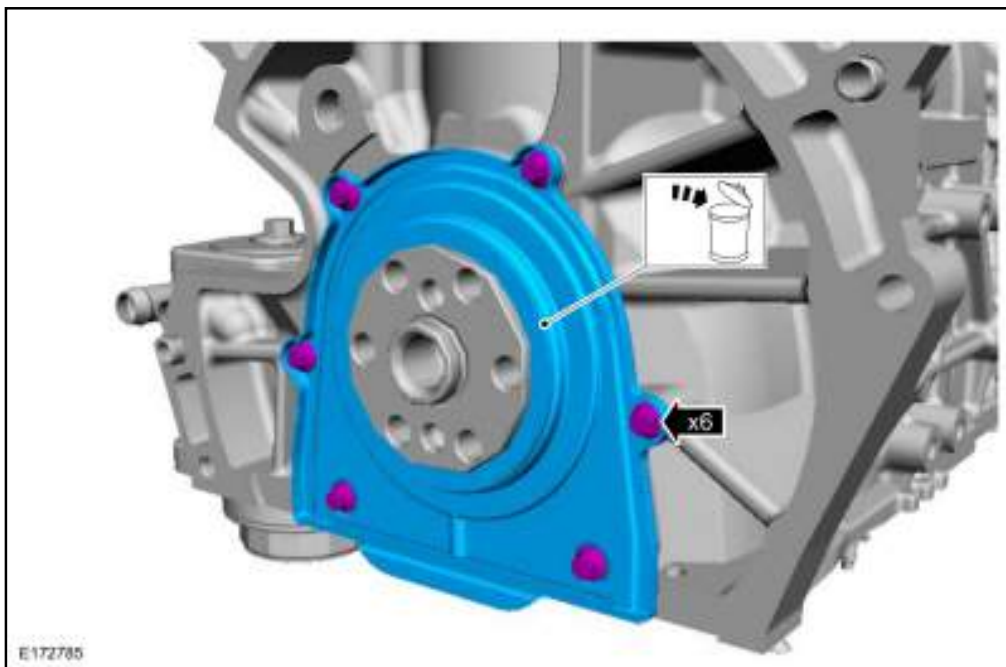





cardiagn.com

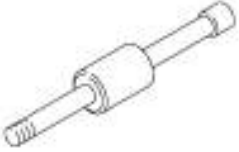

# Cylinder Head

Base Part Number: Base Part Number: 6051

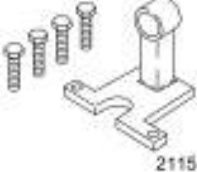
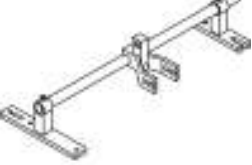
## Special Tool(s) / General Equipment

 <p>15011</p>	<p>205-047 Slide Hammer</p>
 <p>E158911</p>	<p>205-047-08 Adapter for 205-047</p>
 <p>2115502A</p>	<p>303-361-02 Adapter for 303-361A</p>
 <p>2115505</p>	<p>303-361-05 Adapter for 303-361A</p>
 <p>E62757</p>	<p>303-361B Compressor, Valve Spring</p>
 <p>21158</p>	<p>303-362 Installer, Valve Stem Collets</p>

 <p>21211</p>	<p>303-508 Pliers, Valve Stem Seal</p>
 <p>E42916</p>	<p>310-128 Installer Set, Teflon Seal</p>
 <p>E168032</p>	<p>310-206 Remover, Fuel Injector TKIT-2009A-FLM</p>

**Materials**

Name	Specification
Motorcraft® Multi-Purpose Grease Spray XL-5-A	ESB-M1C93-B

**DISASSEMBLY**

1. If equipped.

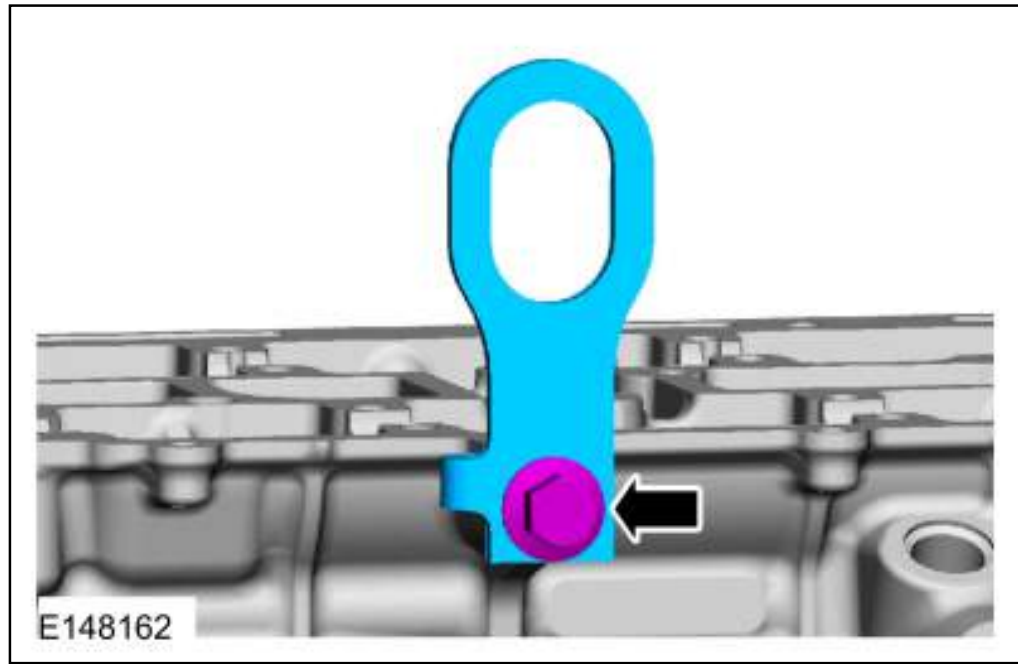

- 2.

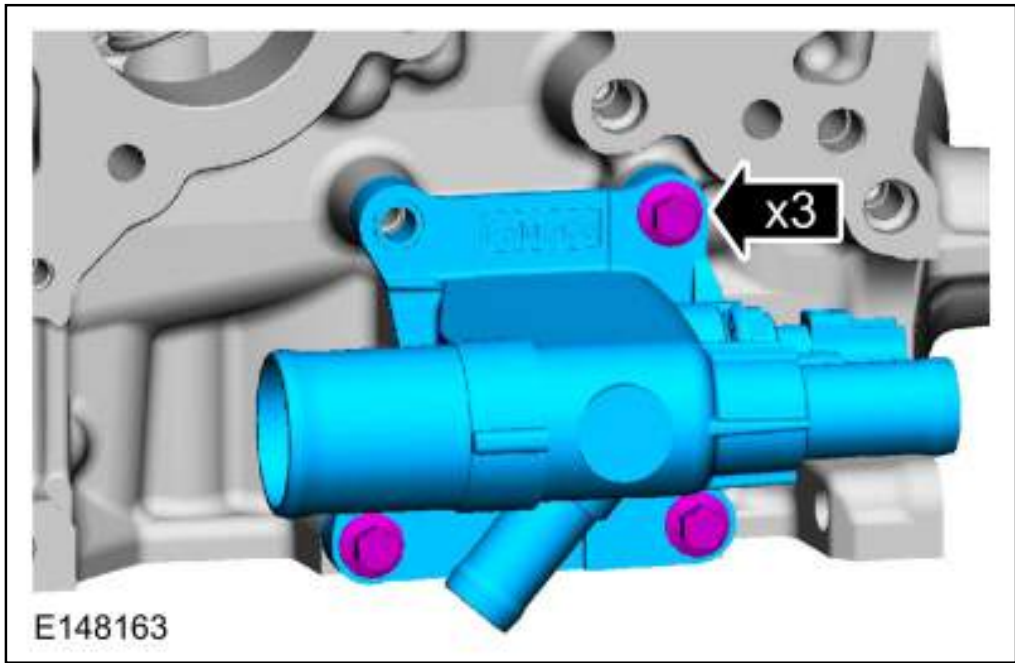

3.

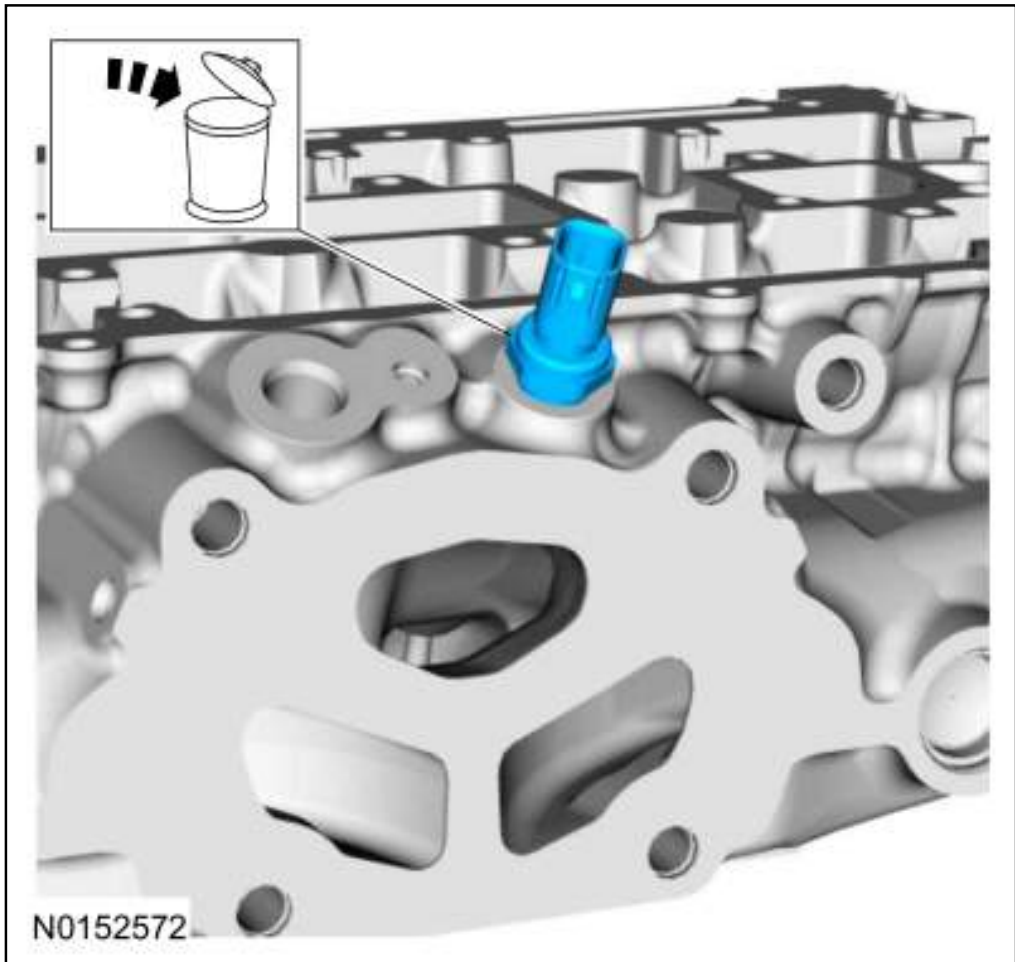

4. **NOTICE:** Take extra care when handling the components.

**NOTE:** Only use moderate force.

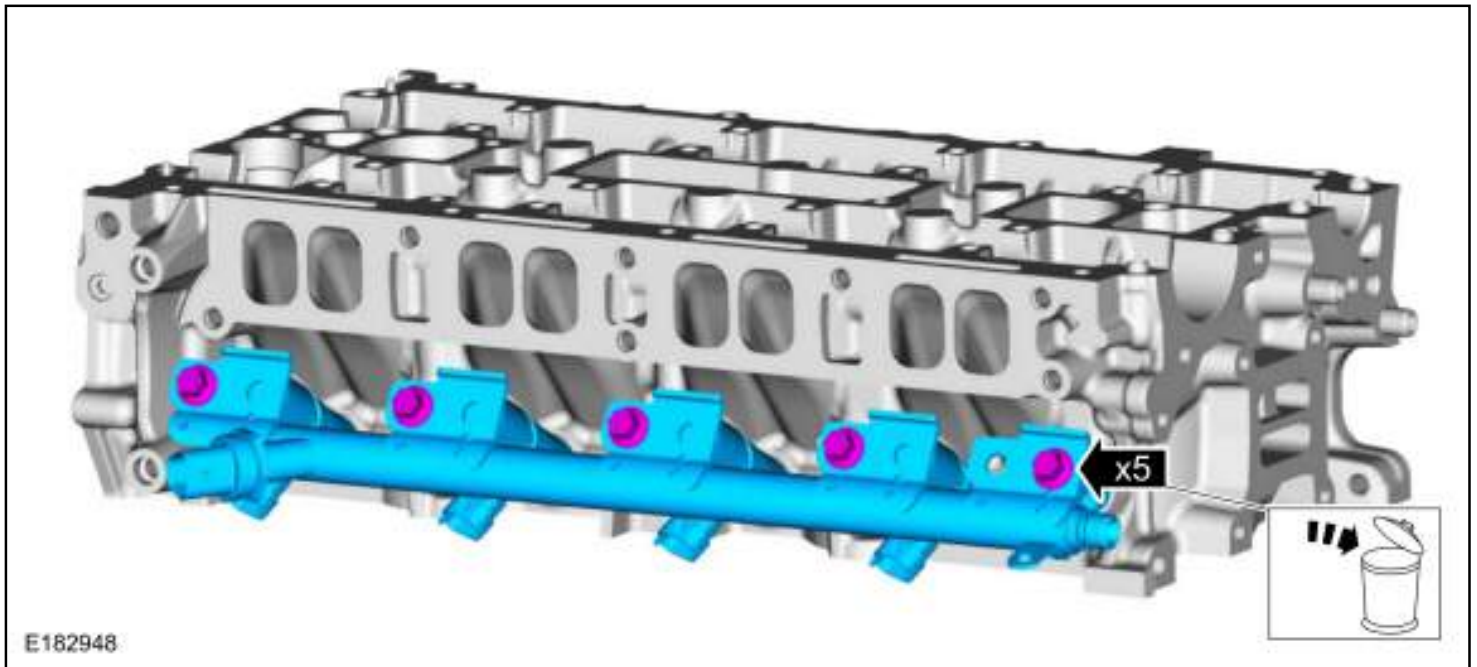

5. **NOTICE:** Take extra care when handling the components.

**NOTE:** Only use moderate force.

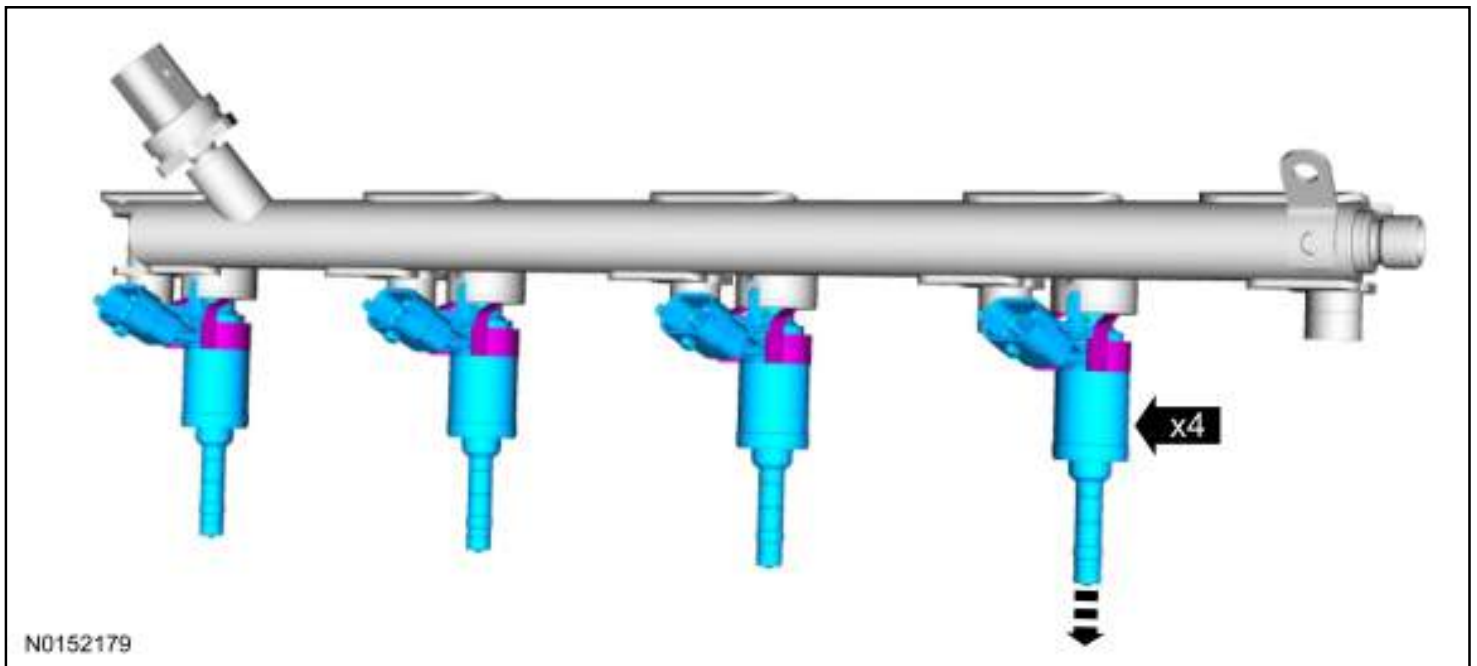

6. **NOTE:** This step is only necessary if the component remains in the cylinder head.

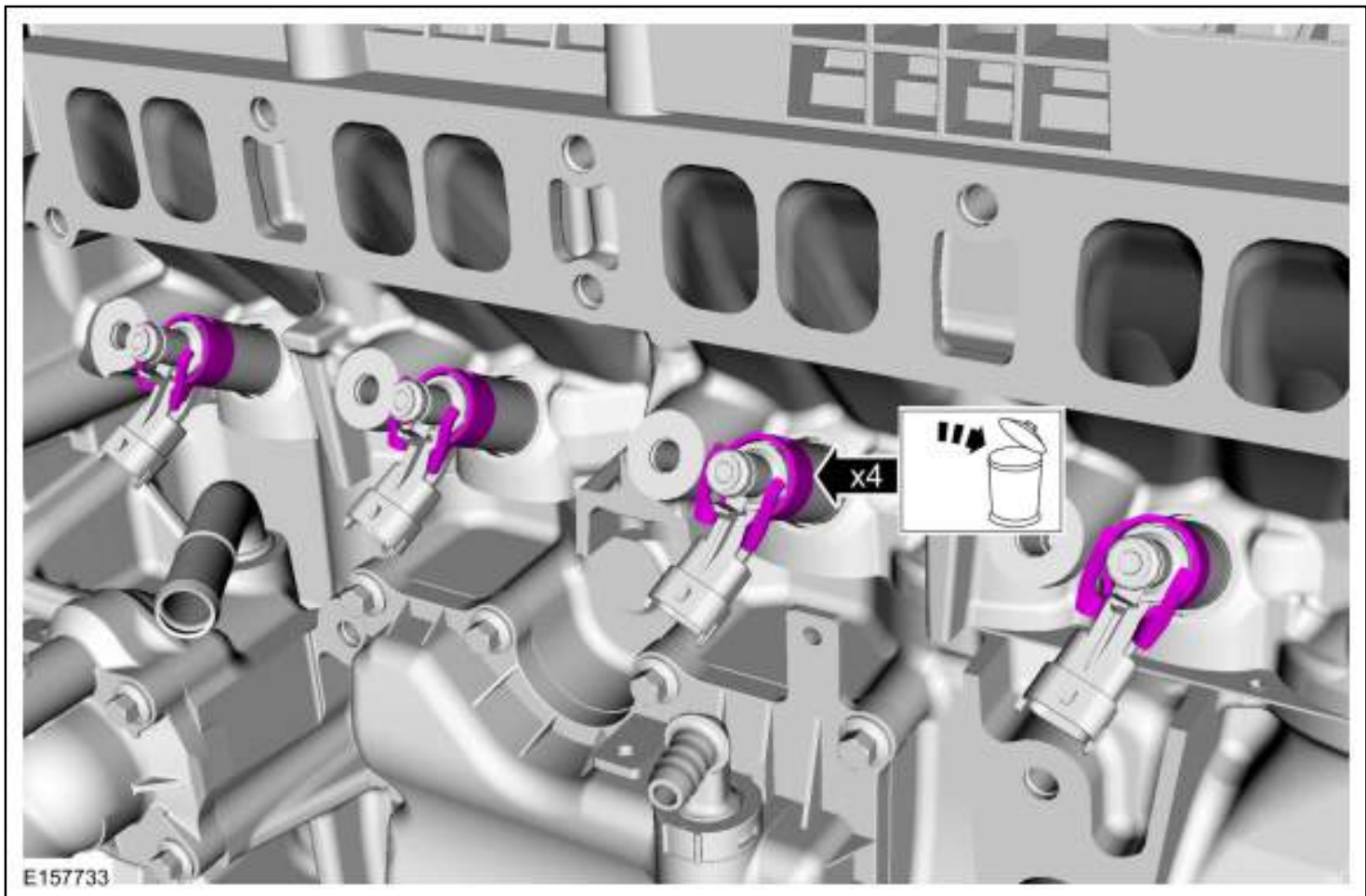

7. **NOTE:** *This step is only necessary if the component remains in the cylinder head.*

Use Special Service Tool: 205-047 Slide Hammer. , 205-047-08 Adapter for 205-047. , 310-206 Remover, Fuel Injector.



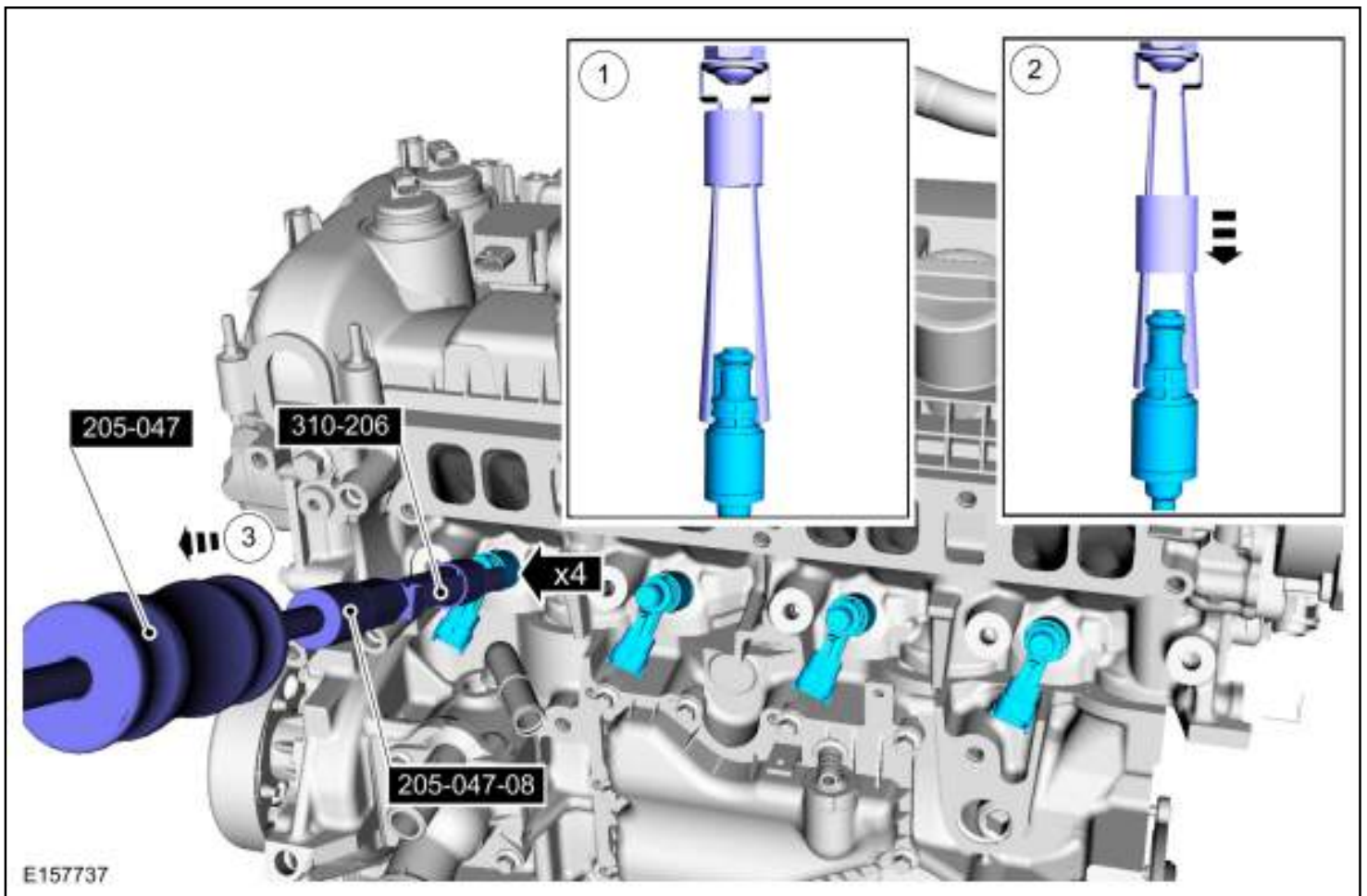

8. **NOTICE:** Take extra care when handling the components.

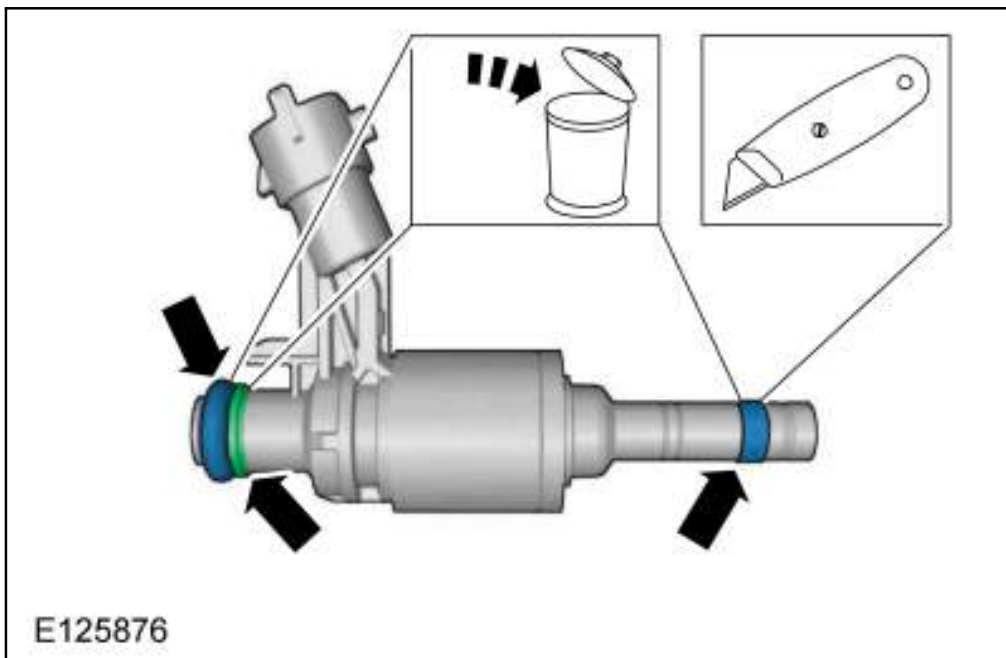

9. **NOTICE:** Make sure that the component is clean, free of foreign material and lubricant.

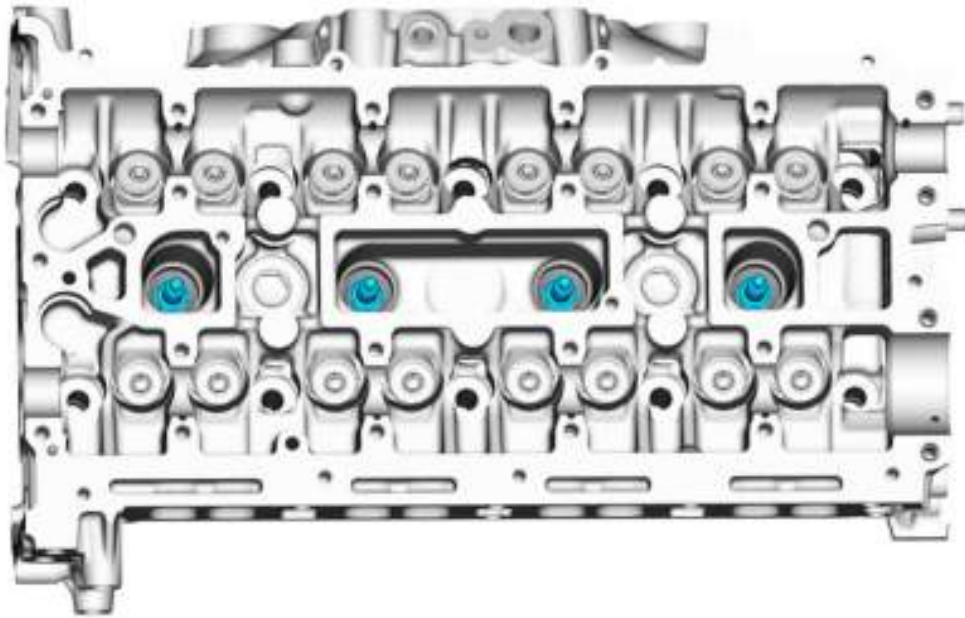

E183494

10. **NOTE:** Note the position of the components before removal.

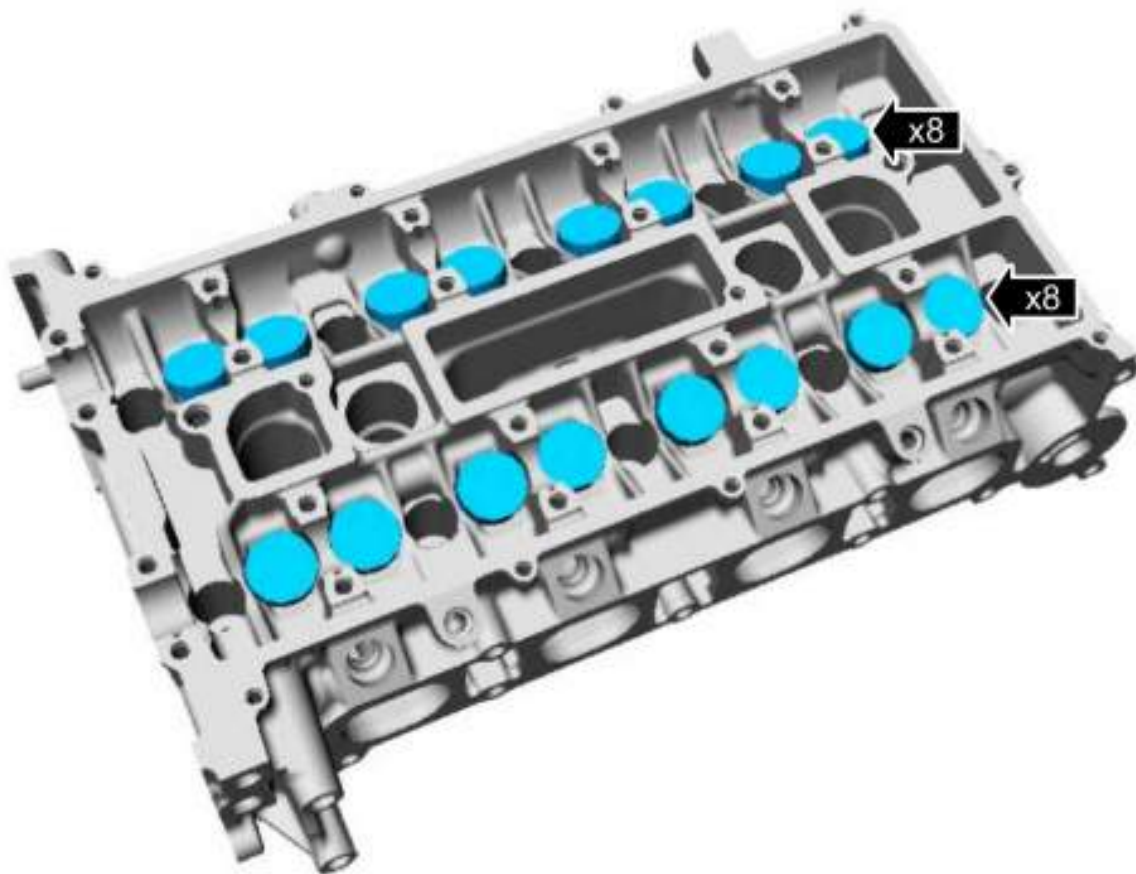

E66111

11. Use Special Service Tool: 303-361B Compressor, Valve Spring , 303-361-02 Adapter for 303-361A. , 303-361-05 Adapter for 303-361A. , 303-362 Installer, Valve Stem Collets.  
*Material:* Motorcraft® Multi-Purpose Grease Spray / XL-5-A (ESB-M1C93-B)

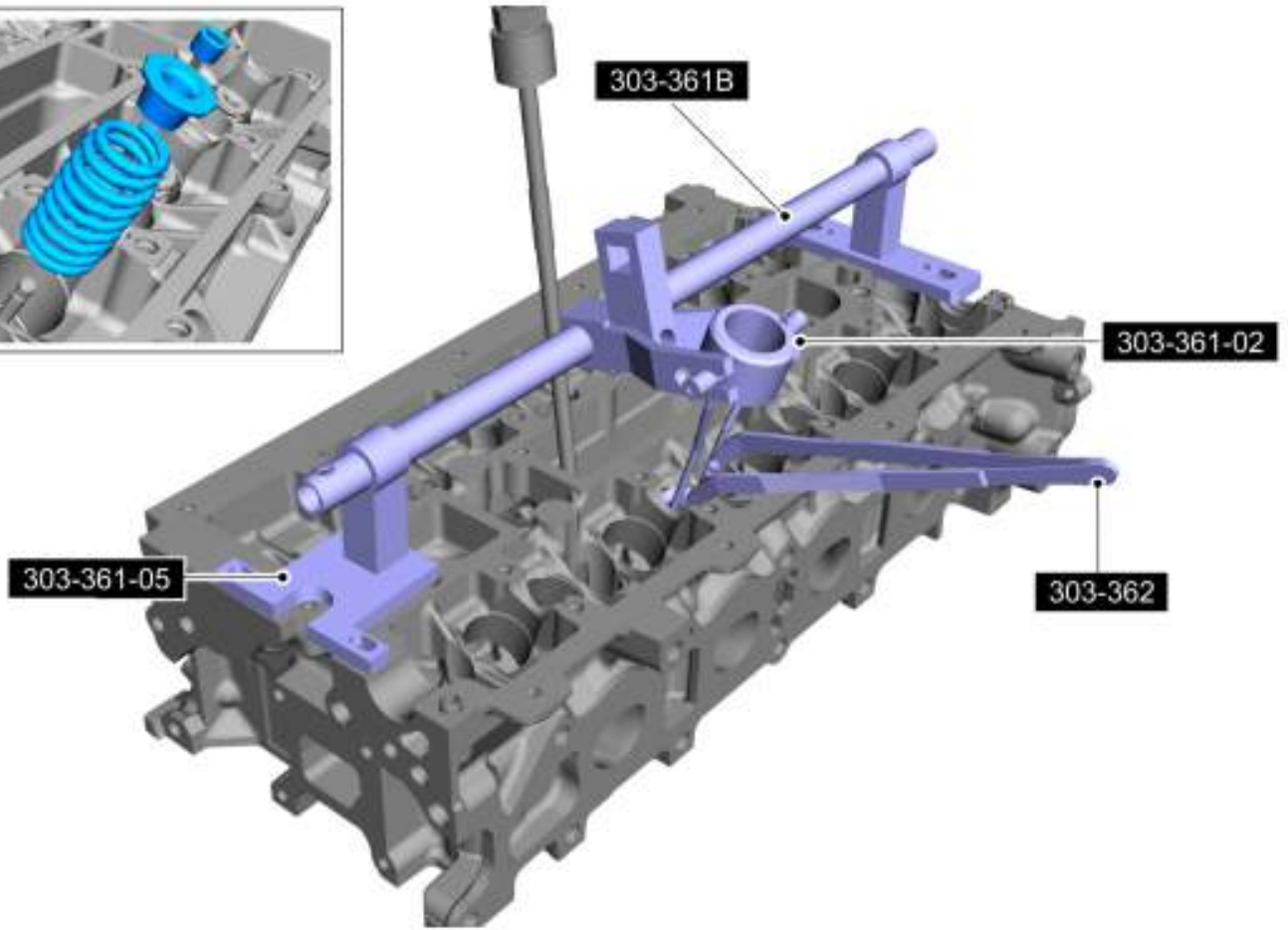

E66113



12.

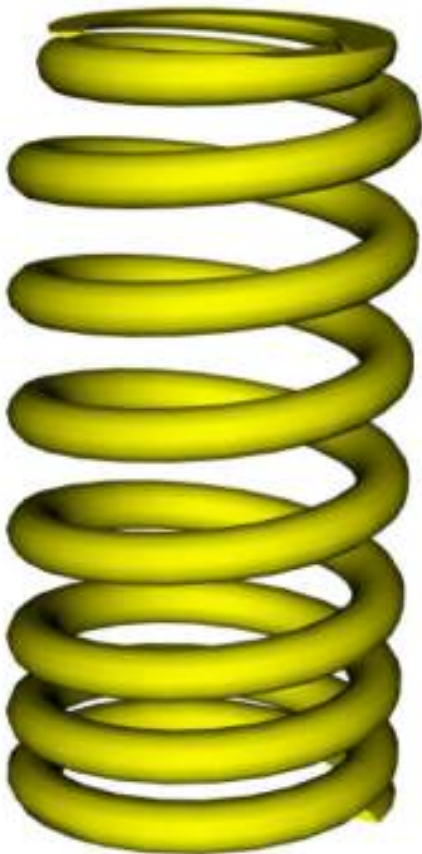

N0152573



13. Use Special Service Tool: 303-508 Pliers, Valve Stem Seal.

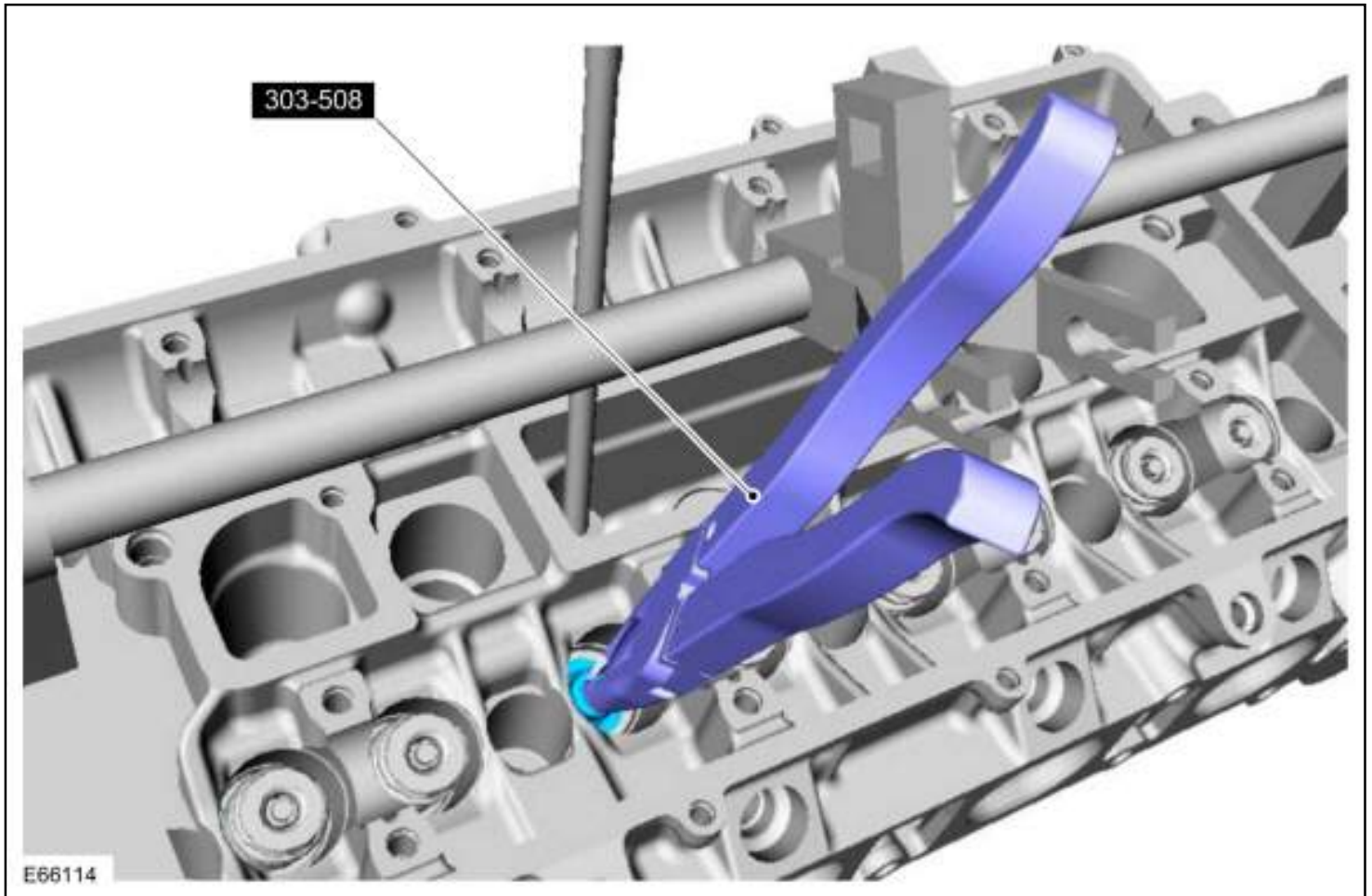

14. **NOTE:** *Note the position of the components before removal.*

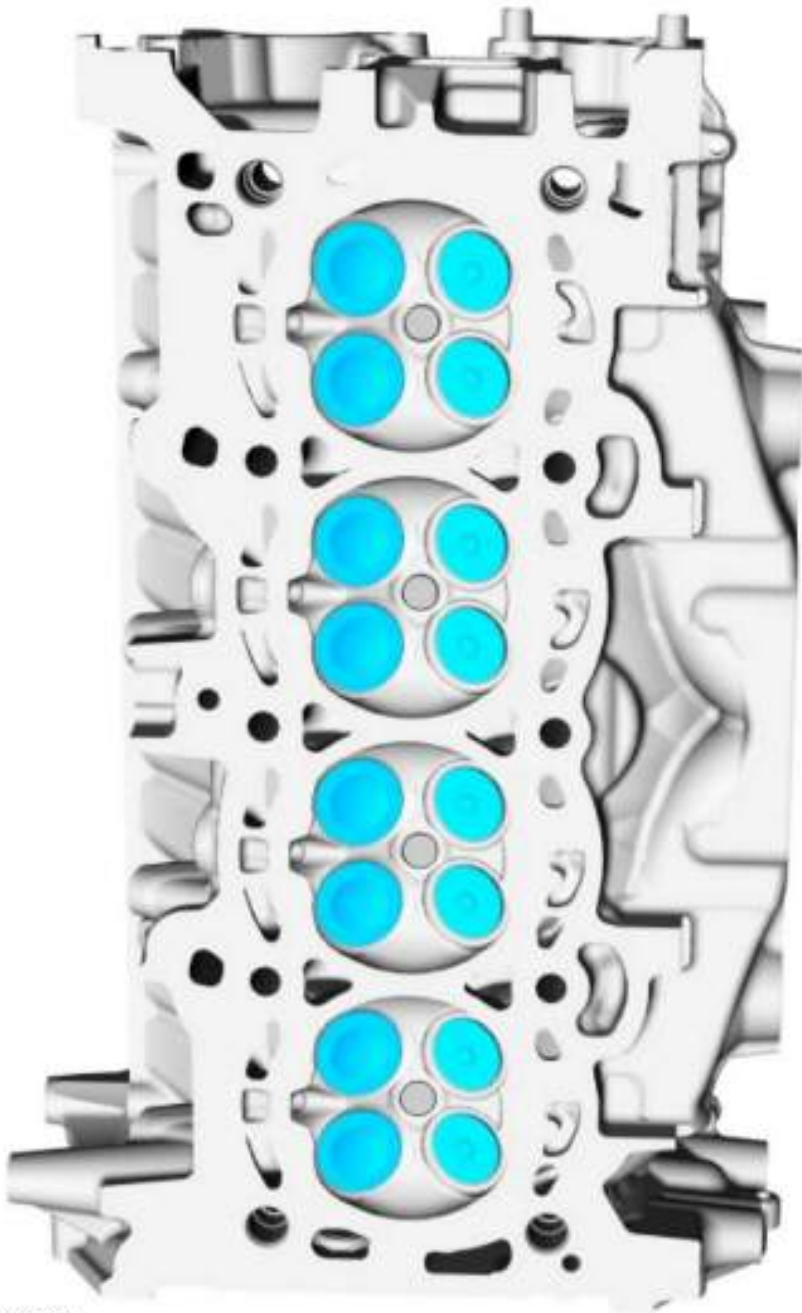

E183605



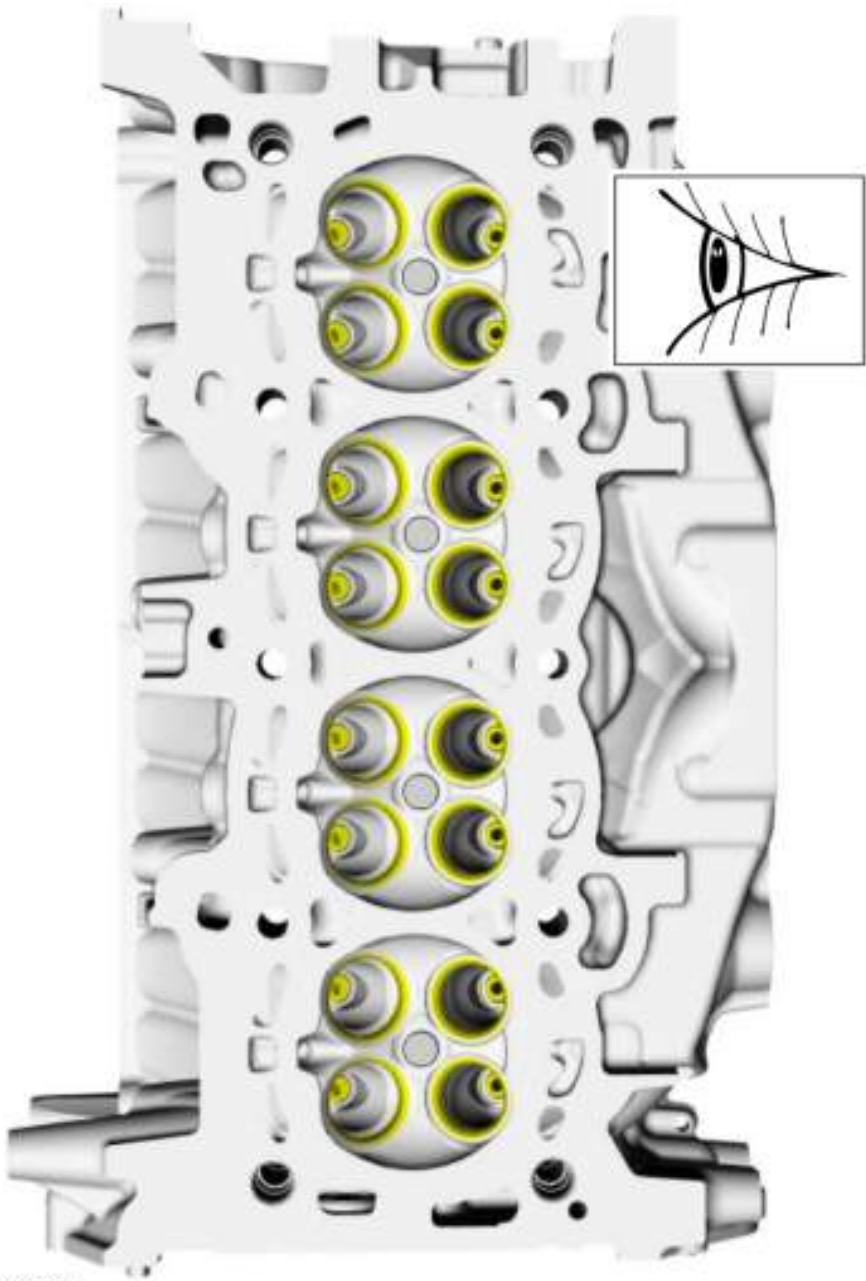

E183606

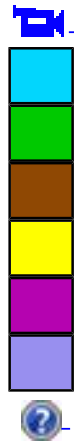

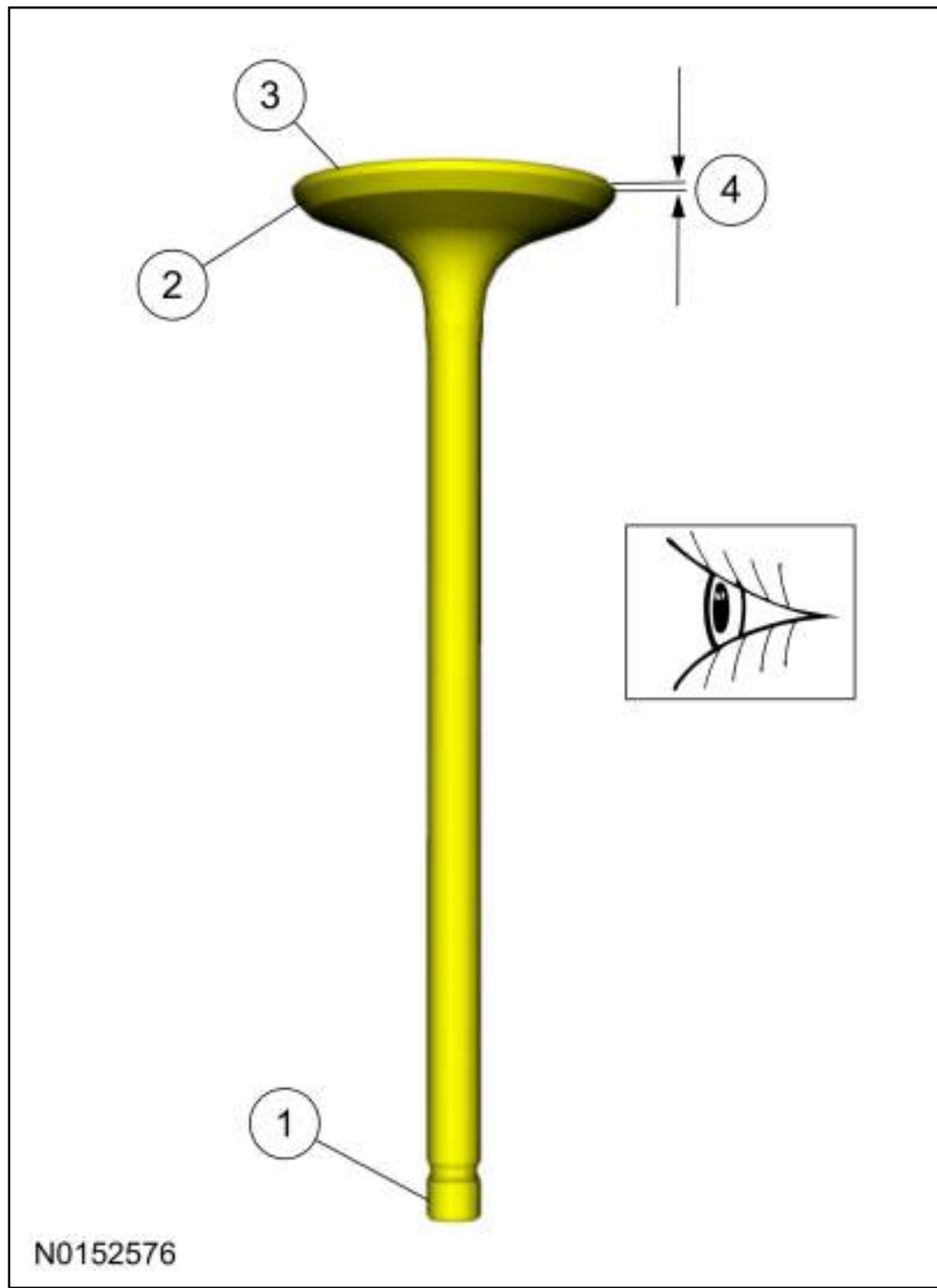

**ASSEMBLY**

1. **NOTE:** *Component must be lubricated with clean engine oil.*

**NOTE:** *Make sure that the components are installed to the position noted before removal.*

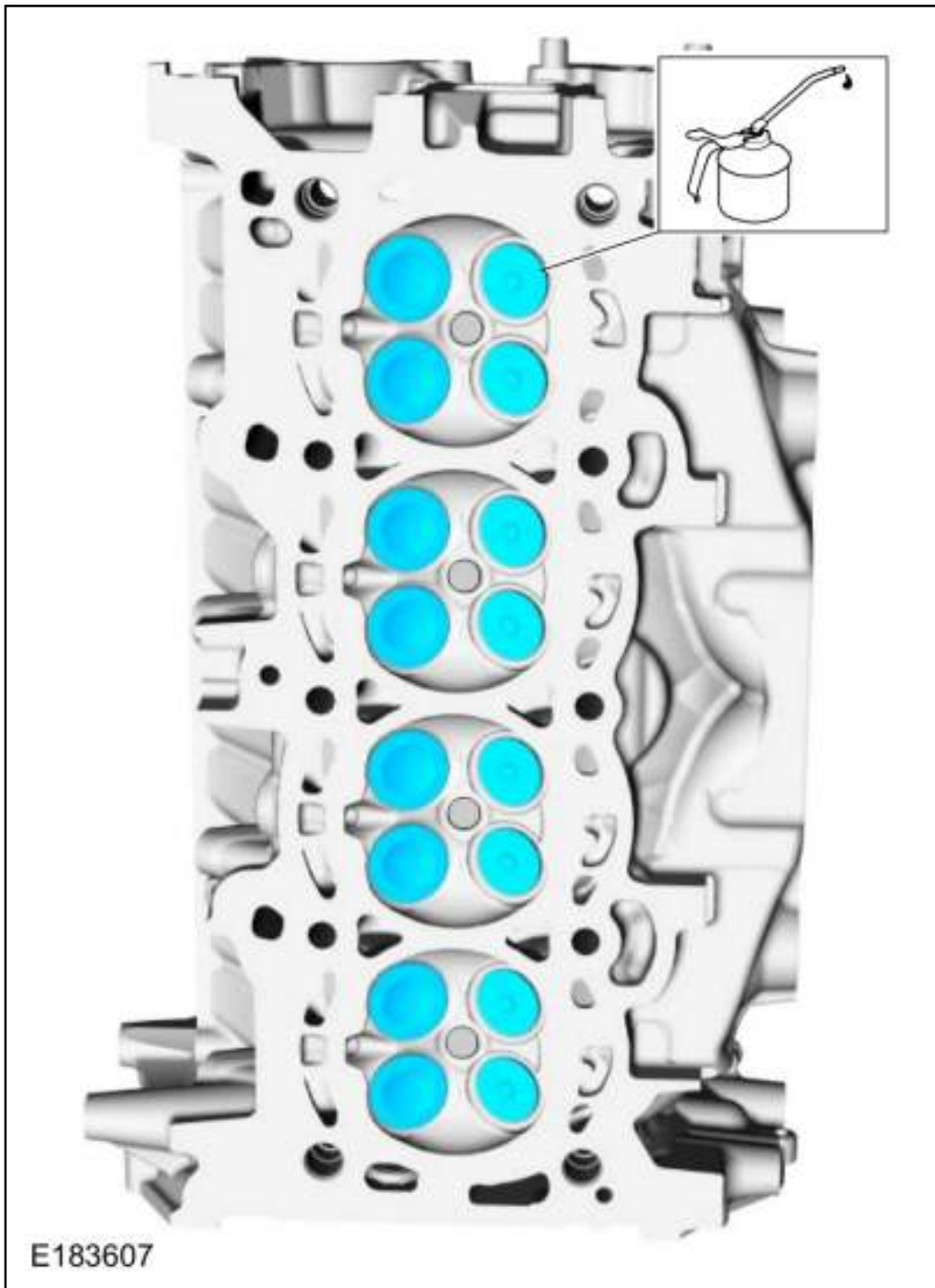

2. **NOTE:** *Make sure that a new component is installed.*

Use Special Service Tool: 303-508 Pliers, Valve Stem Seal.

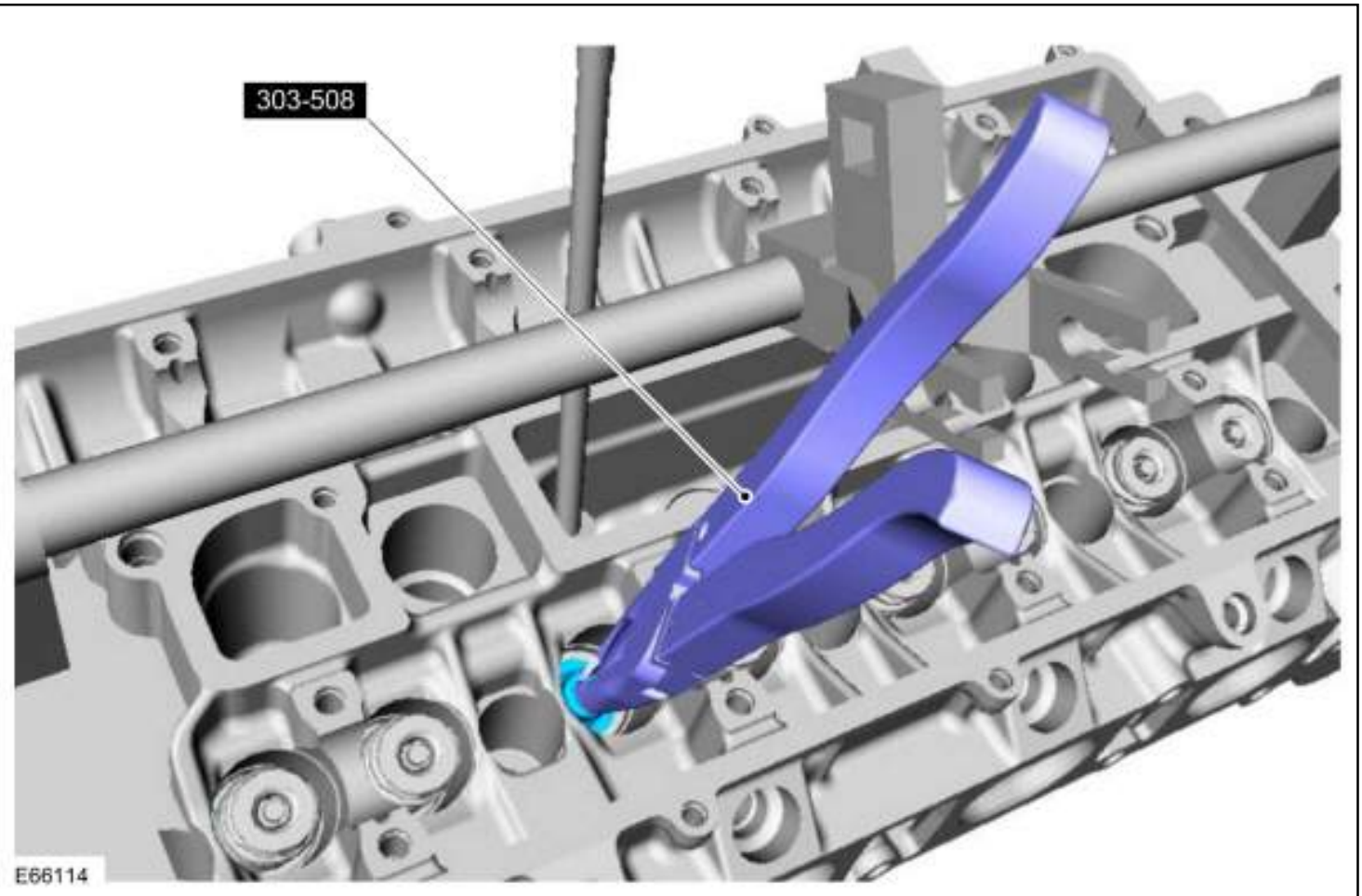

3. Use Special Service Tool: 303-361B Compressor, Valve Spring. , 303-361-02 Adapter for 303-361A. , 303-361-05 Adapter for 303-361A. , 303-362 Installer, Valve Stem Collets.  
*Material:* Motorcraft® Multi-Purpose Grease Spray / XL-5-A (ESB-M1C93-B)

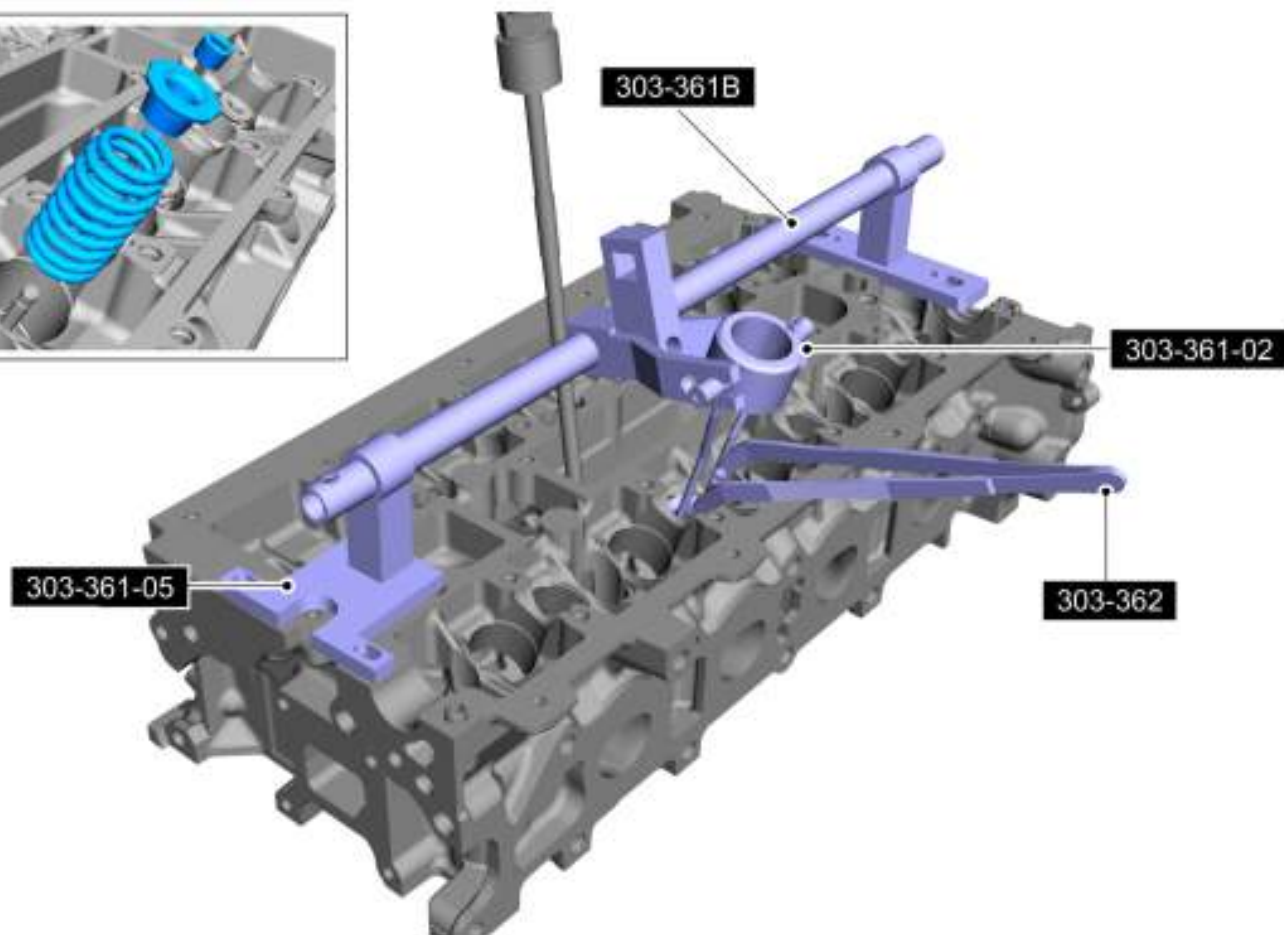

E66113

4. **NOTICE:** Make sure that the component is clean, free of foreign material and lubricant.

**NOTE:** Make sure that the components are installed to the position noted before removal.

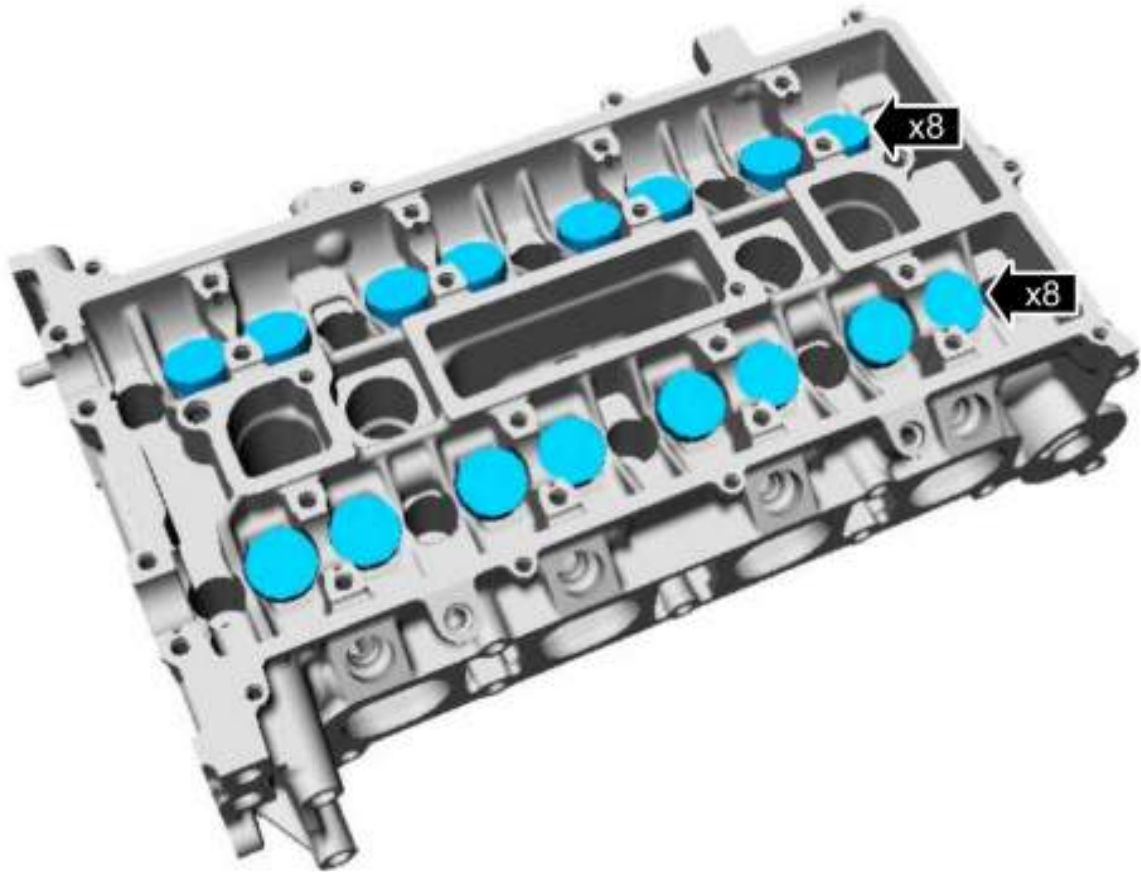

E66111

5. *Torque:* 106 lb.in (12 Nm)

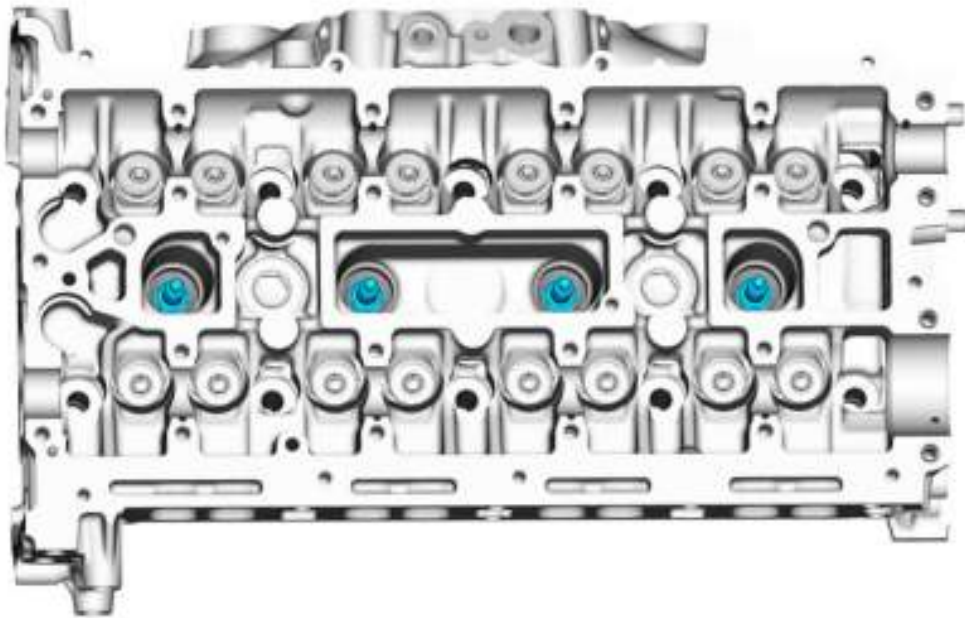

E183494

6. **NOTICE:** Make sure that tools and equipment are clean, free of foreign material and lubricant.

**NOTICE:** Make sure that the component is clean, free of foreign material and lubricant.

**NOTICE:** Take extra care when handling the component.



**NOTE:** Only use moderate force.

1. Use Special Service Tool: 310-128 Installer Set, Teflon Seal.
2. **NOTE:** Make sure that a new component is installed.
3. Use Special Service Tool: 310-128 Installer Set, Teflon Seal.
4. Use Special Service Tool: 310-128 Installer Set, Teflon Seal.

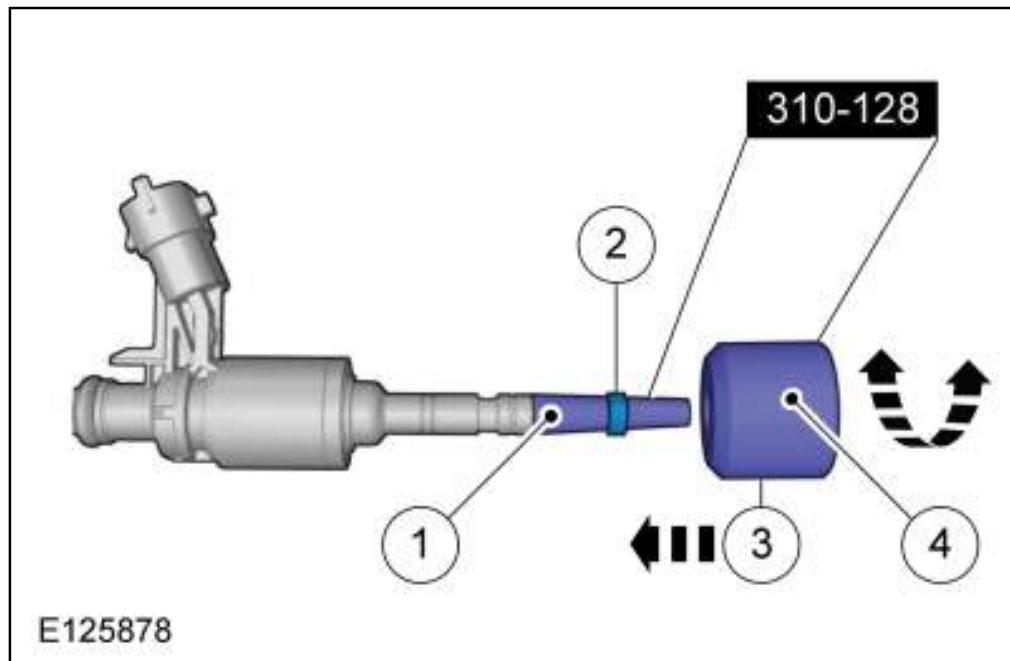

7. **NOTICE:** Make sure that the component is clean, free of foreign material and lubricant.

**NOTICE:** Take extra care when handling the components.

1. **NOTE:** Make sure that a new component is installed.
2. **NOTE:** Make sure that a new component is installed.

**NOTE:** Component must be lubricated with clean engine oil.

3. **NOTE:** Make sure that a new component is installed.

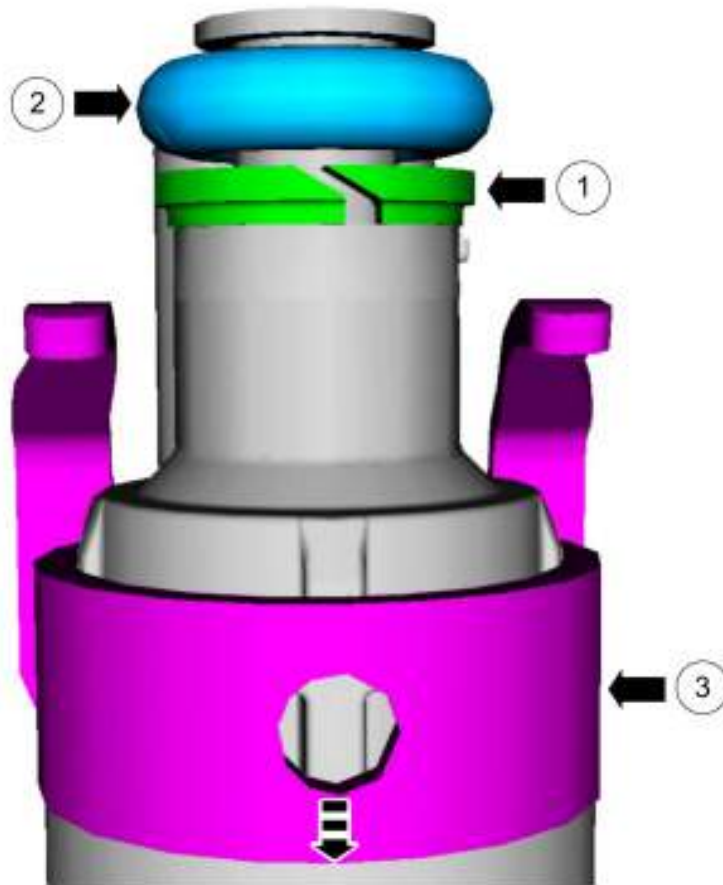

E168451

8.

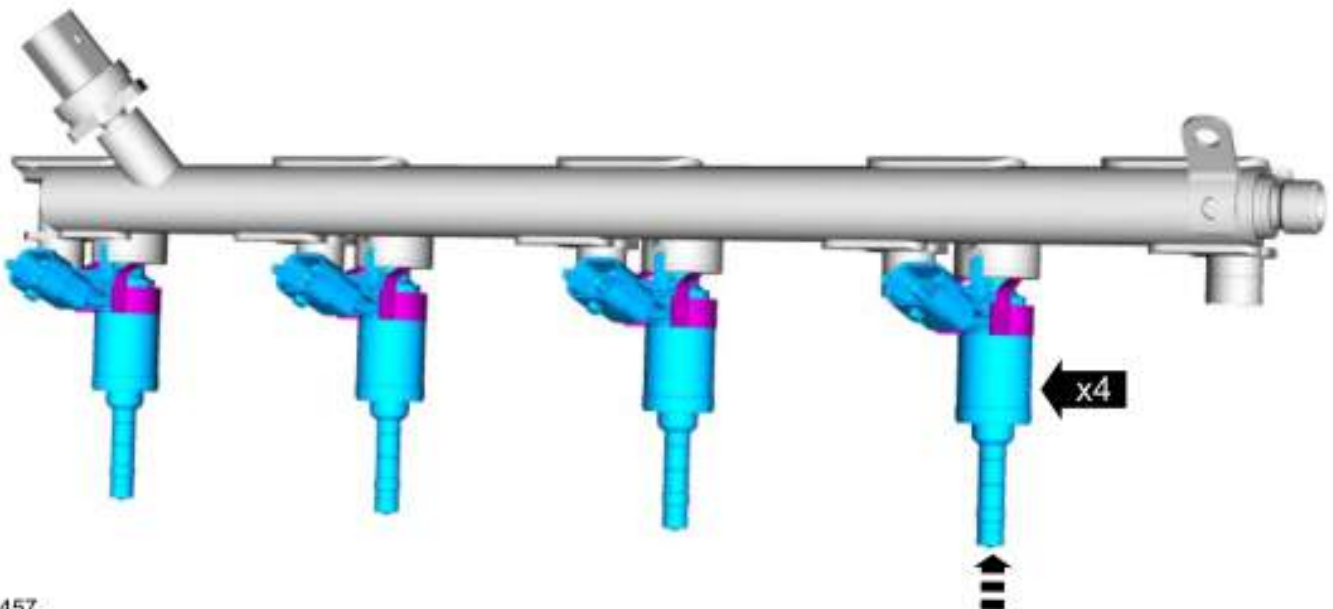

N0152457

9. **NOTICE:** Make sure that the area around the component is clean and free of foreign material.

**NOTICE:** Make sure that the component is clean and free of foreign material.

**NOTICE:** Take extra care when handling the components.

**NOTE:** Only use moderate force.

**NOTE:** Install all the bolts finger tight before final tightening.

Tighten each bolt 1 turn at a time.

10. *Torque:*

Stage 1: 71 lb.in (8 Nm)

Stage 2: 26°

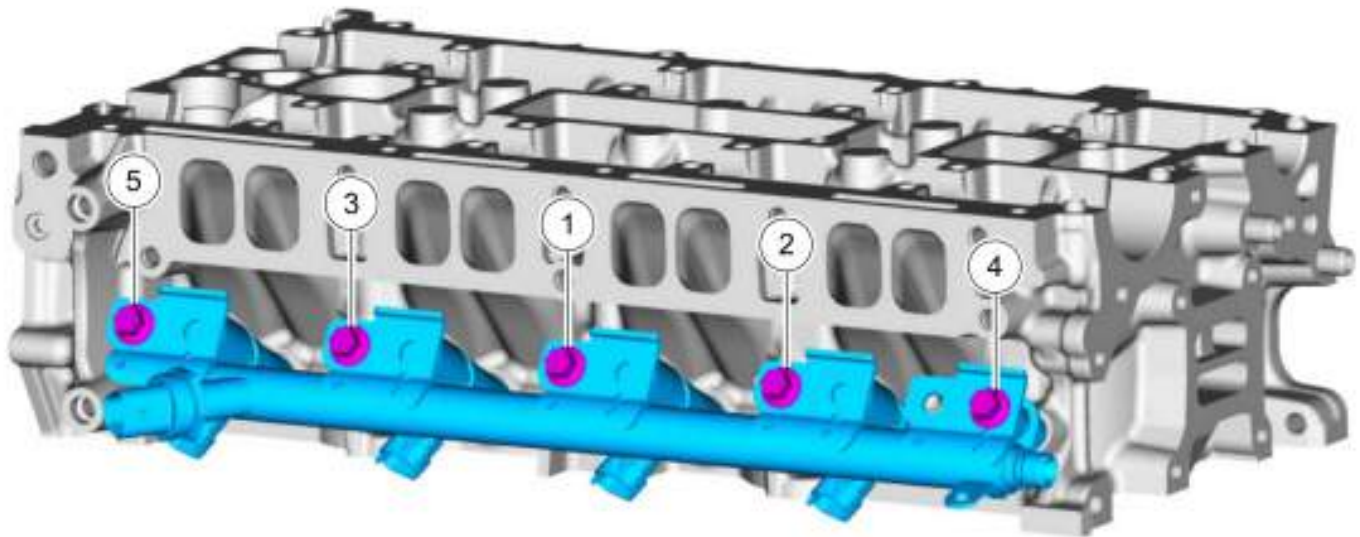

11. **NOTE:** Make sure that a new component is installed.

*Torque:* 97 lb.in (11 Nm)

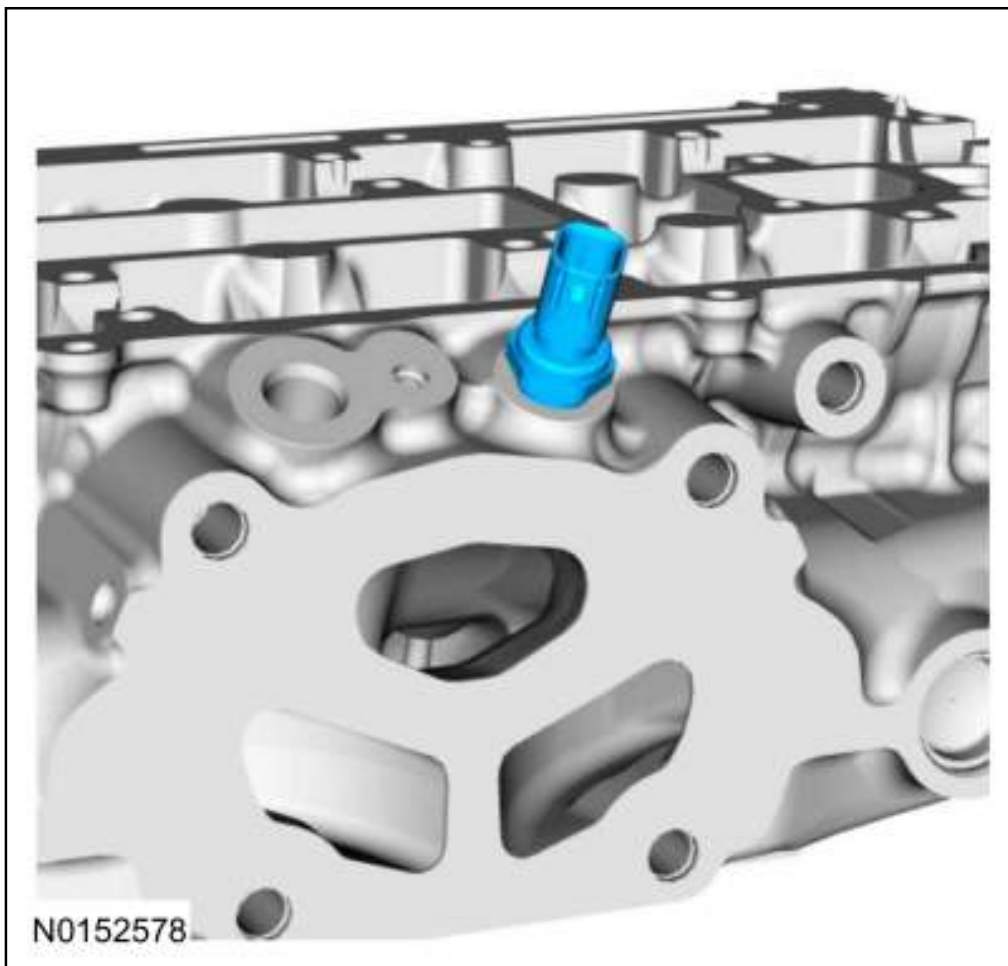

12. **NOTE:** *The O-ring seal is to be reused unless damaged.*

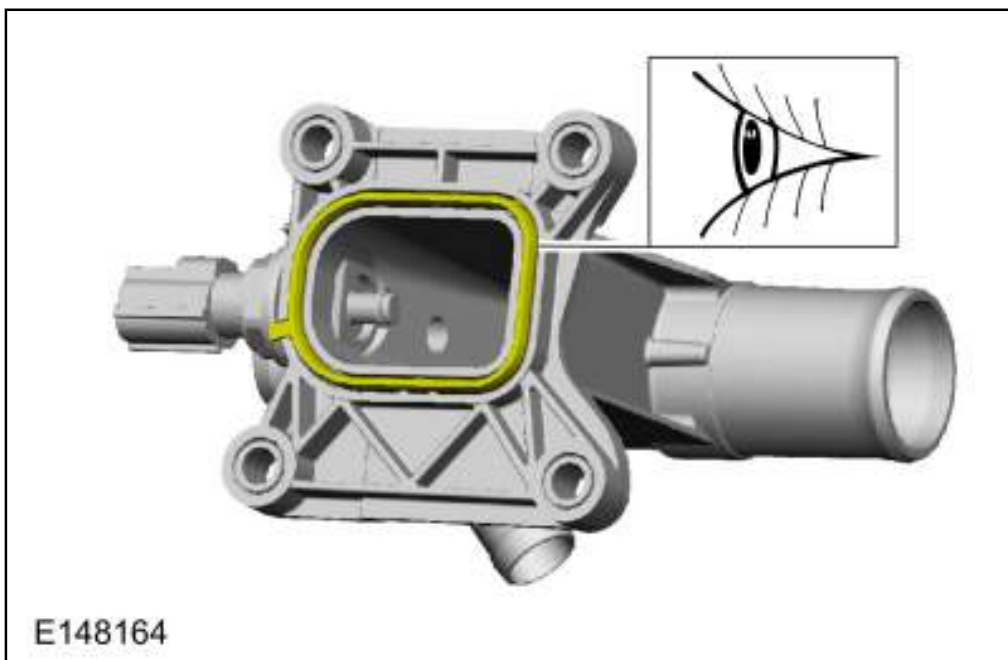

13. *Torque: 89 lb.in (10 Nm)*

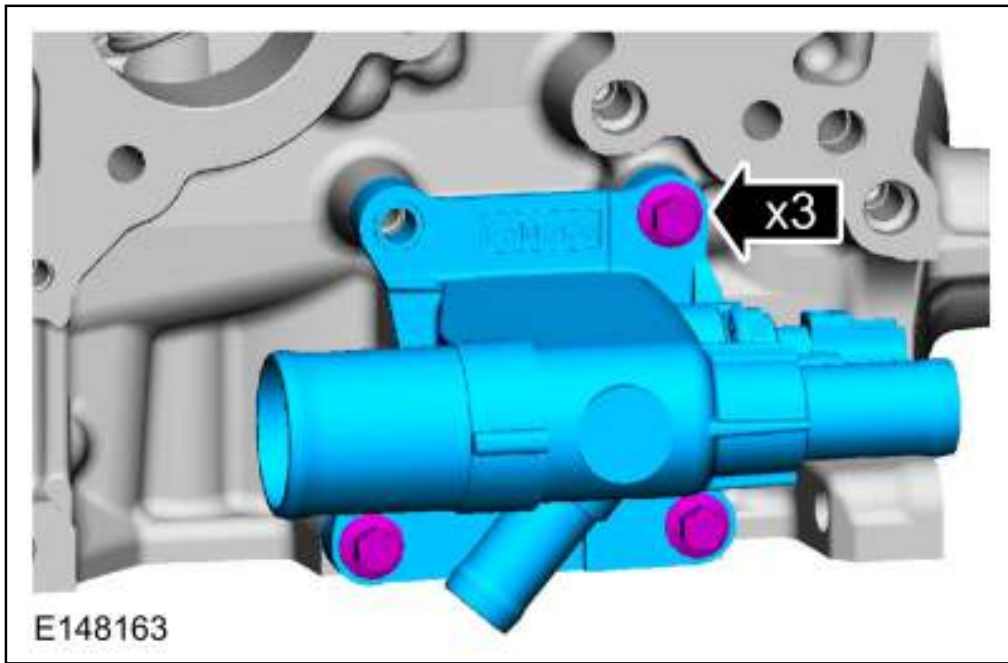

14. If equipped.  
*Torque: 35 lb.ft (47 Nm)*

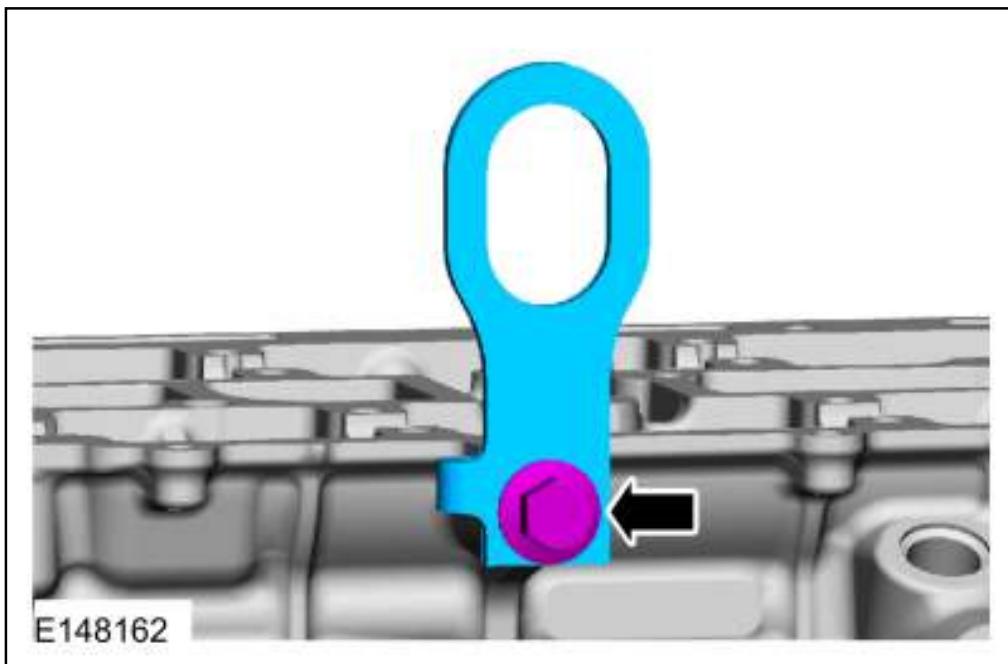



# Valve Clearance Adjustment

## Special Tool(s) / General Equipment

	303-499 Socket, Spark Plug
Feeler Gauge	

## Check

1. Refer to: [Valve Cover](#) (303-01C Engine, Removal and Installation).
2. Use Special Service Tool: 303-499 Socket, Spark Plug.  
*Torque: 106 lb.in (12 Nm)*

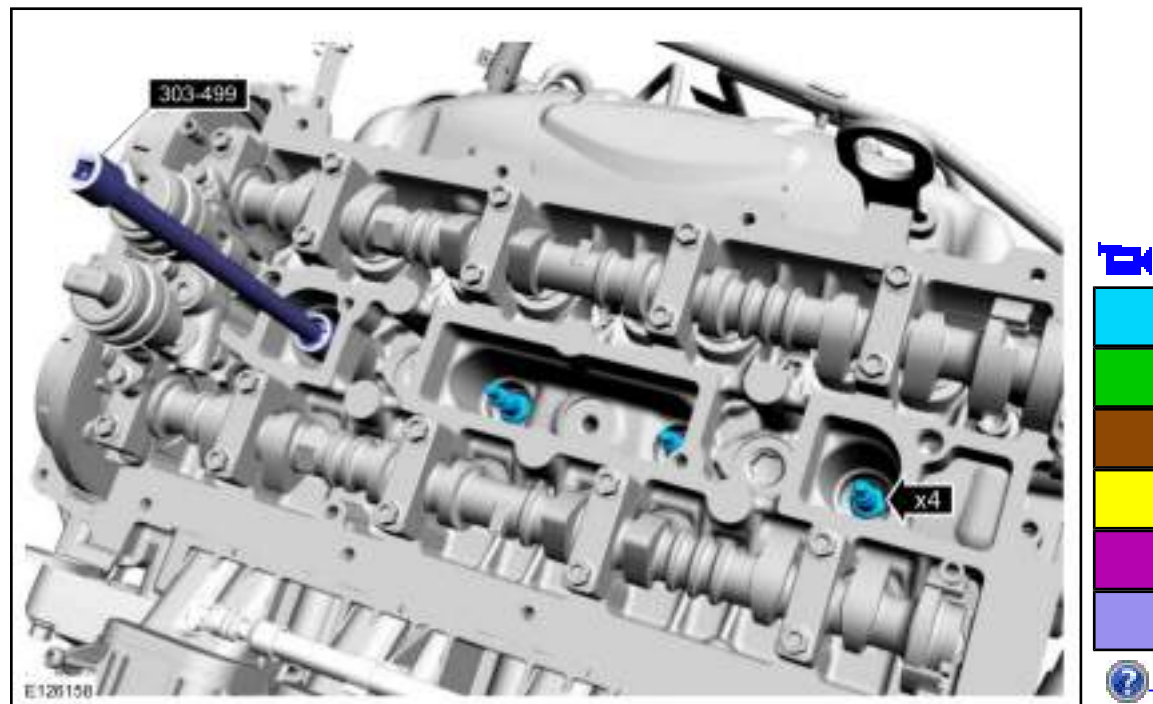

3. **NOTICE: Only rotate the crankshaft clockwise.**

Rotate the crankshaft until each piston is at top dead center (TDC) and measure the valve clearance(s) using a suitable set of feeler gauges.

4. Measure and note the valve clearance values.  
Use the General Equipment: Feeler Gauge
5. Compare the measured valve clearance(s) with the specifications.  
Refer to: [Specifications](#) (303-01C Engine, Specifications).

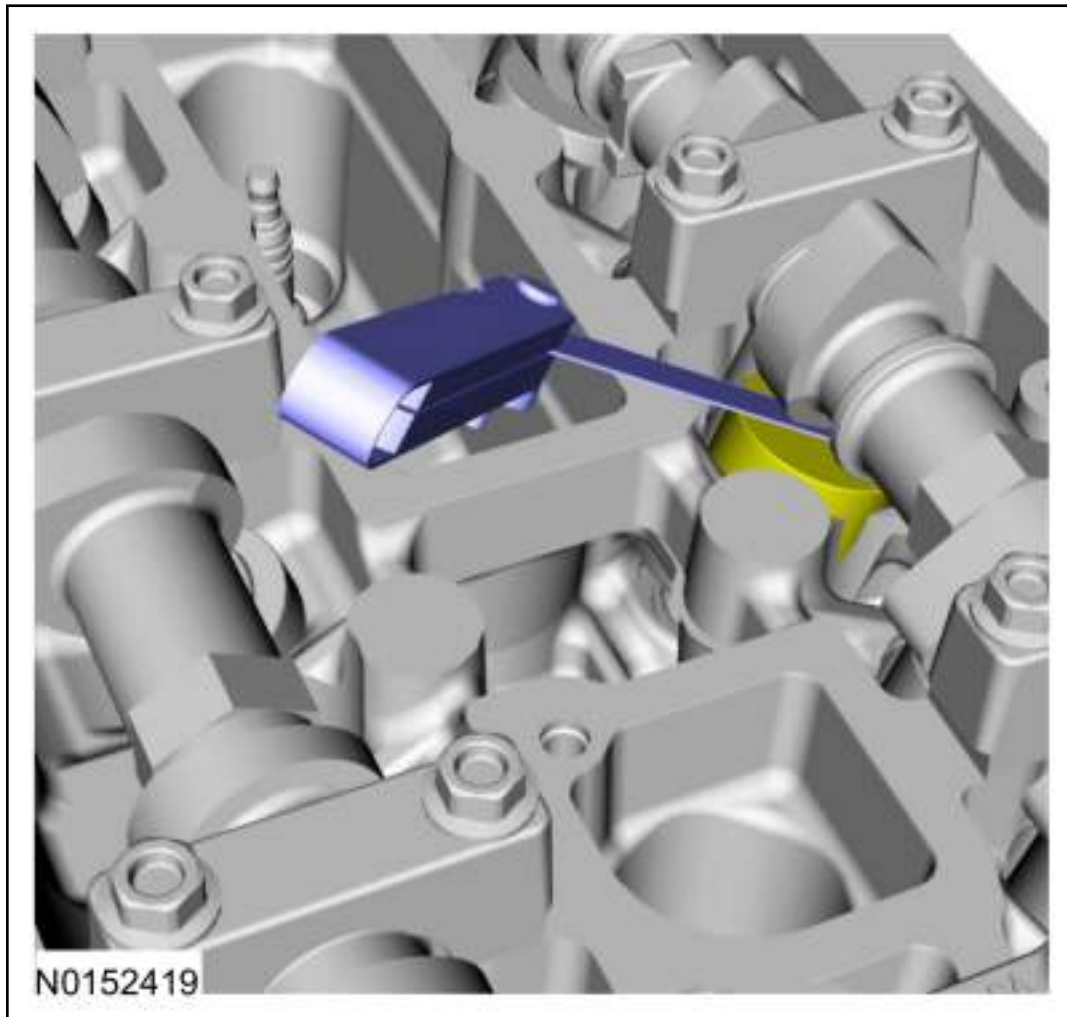

## Adjustment

1. **NOTE:** *The following steps are only necessary if adjustment is required.*
2. Refer to: [Camshafts](#) (303-01C Engine, Removal and Installation).
  - Remove the valve tappet and read the thickness from the underside.
  - The number on the valve tappet indicates the thickness of the bottom of the tappet. However, the number only indicates the digits after the decimal point (example: .650 = 3,650).
  - Calculate the required thickness of the valve tappet with the following formula:  $X = S + M - V$
  - Required thickness of tappet = X
  - Thickness of currently fitted tappet = S

- Measurement of existing valve clearance (actual value) = M
- Desired valve clearance = V

5. Install the correct valve tappet.
6. Refer to: [Camshafts](#) (303-01C Engine, Removal and Installation).
7. Measure and note the valve clearance values.
8. Compare the measured valve clearance(s) with the specifications.  
Refer to: [Specifications](#) (303-01C Engine, Specifications).
9. Repeat the procedure as necessary until all valve clearances are within the specified tolerance.

Copyright © 2019 Ford Motor Company

---

## Engine Accessories

### Special Tool(s) / General Equipment

 E55029	303-393-02 Adapter for 303-393 TKIT-2012A-FL TKIT-2012A-ROW
 E63417	303-393A Locking Tool, Flywheel TKIT-2012A-FL TKIT-2012A-ROW
 E252718	303-435 Mounting Stand
 E252723	303-435-06 Mounting Bracket for 303-435
 E68386	303-435-11B Mounting Plate for 303-435-06
Lifting Bracket	
Floor Crane	
Hose Clamp Remover/Installer	

cardiagn.com

### Materials

Name	Specification
Engine Oil - SAE 0W-40	WSS-M2C937-A

1. **NOTE:** Make sure that new bolts are installed.

Use Special Service Tool: 303-393A Locking Tool, Flywheel. , 303-393-02 Adapter for 303-393.

*Torque:*

Stage 1: 37 lb.ft (50 Nm)

Stage 2: 59 lb.ft (80 Nm)

Stage 3: 83 lb.ft (112 Nm)

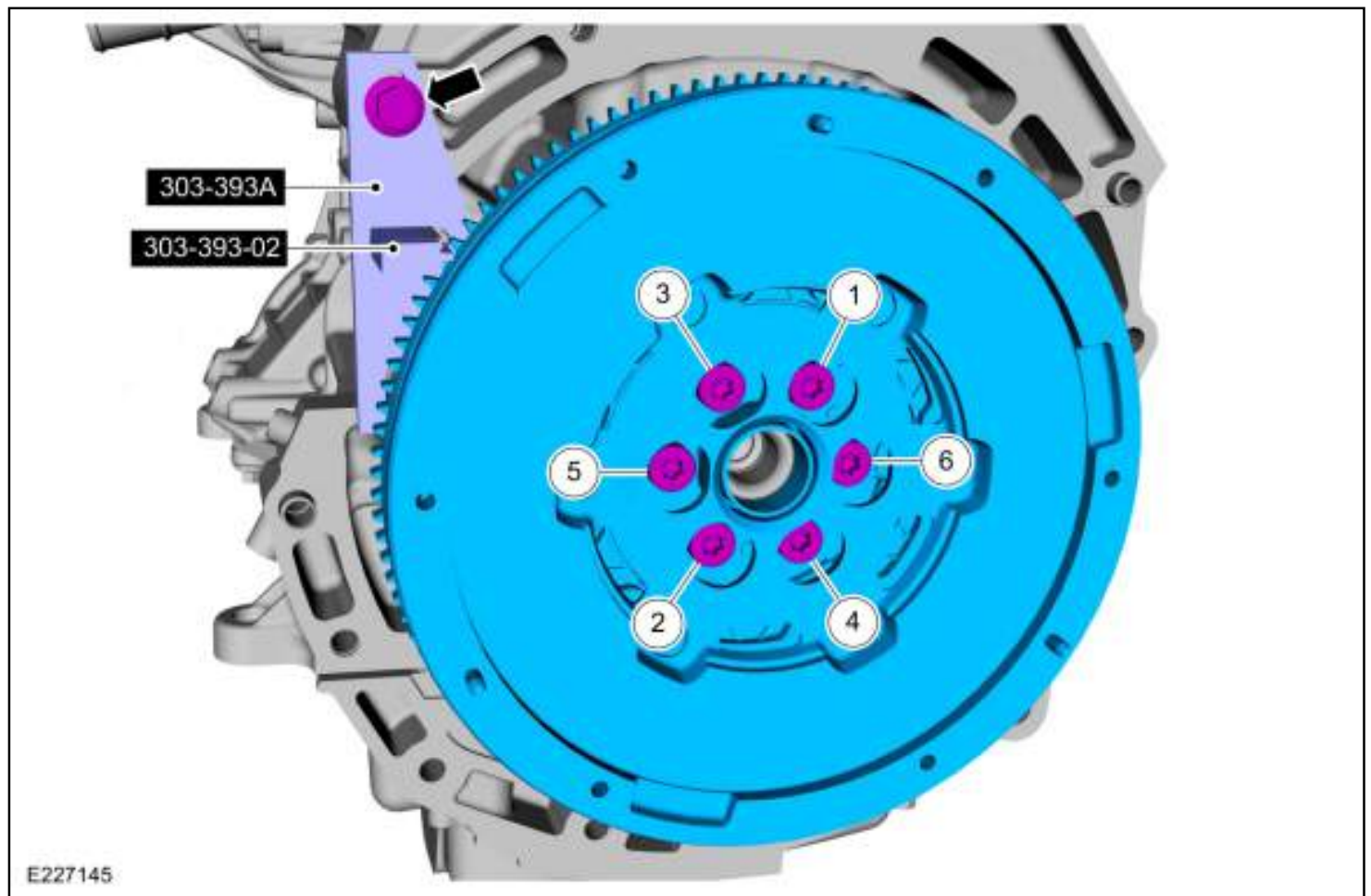

2. Refer to: Clutch Disc and Pressure Plate (308-01 Clutch - 6-Speed Manual Transmission - MMT6) .

3. **NOTICE:** Make sure that the component is clean, free of foreign material and lubricant.

**NOTE:** Make sure that new components are installed.

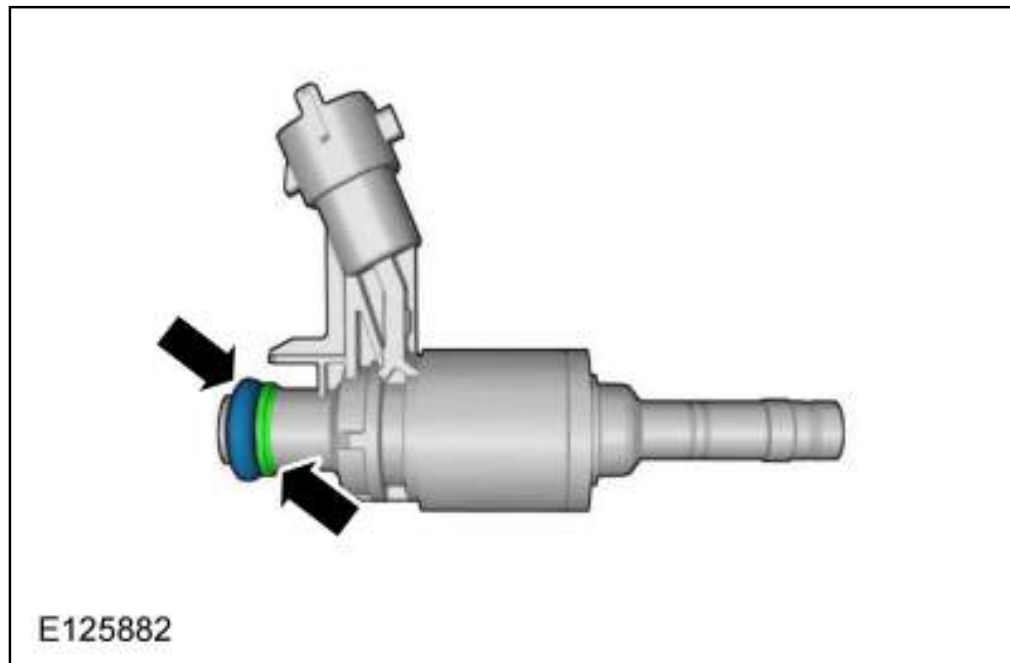

E125882

4. **NOTICE:** Make sure that tools and equipment are clean, free of foreign material and lubricant.

**NOTICE:** Make sure that the component is clean, free of foreign material and lubricant.

**NOTE:** Make sure that a new component is installed.

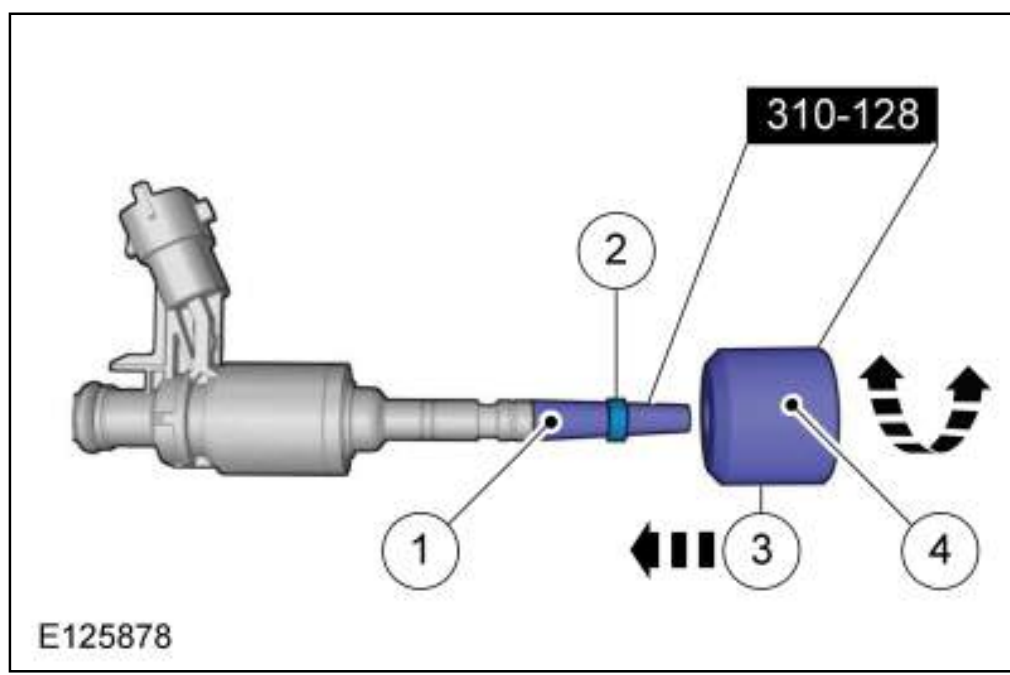

E125878

5. **NOTE:** Make sure that a new component is installed.

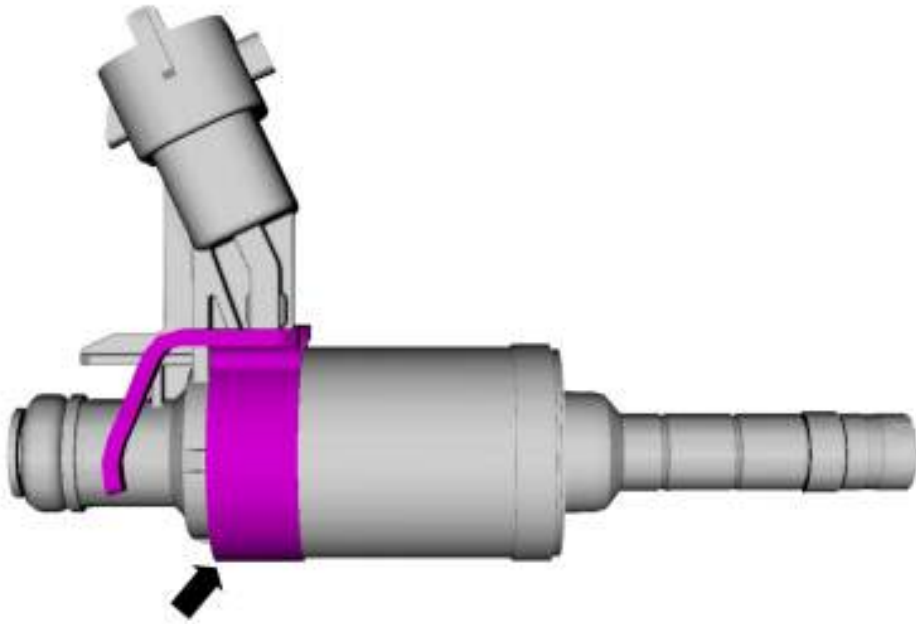

E146967

6. *Material:* Engine Oil - SAE 0W-40 (WSS-M2C937-A)

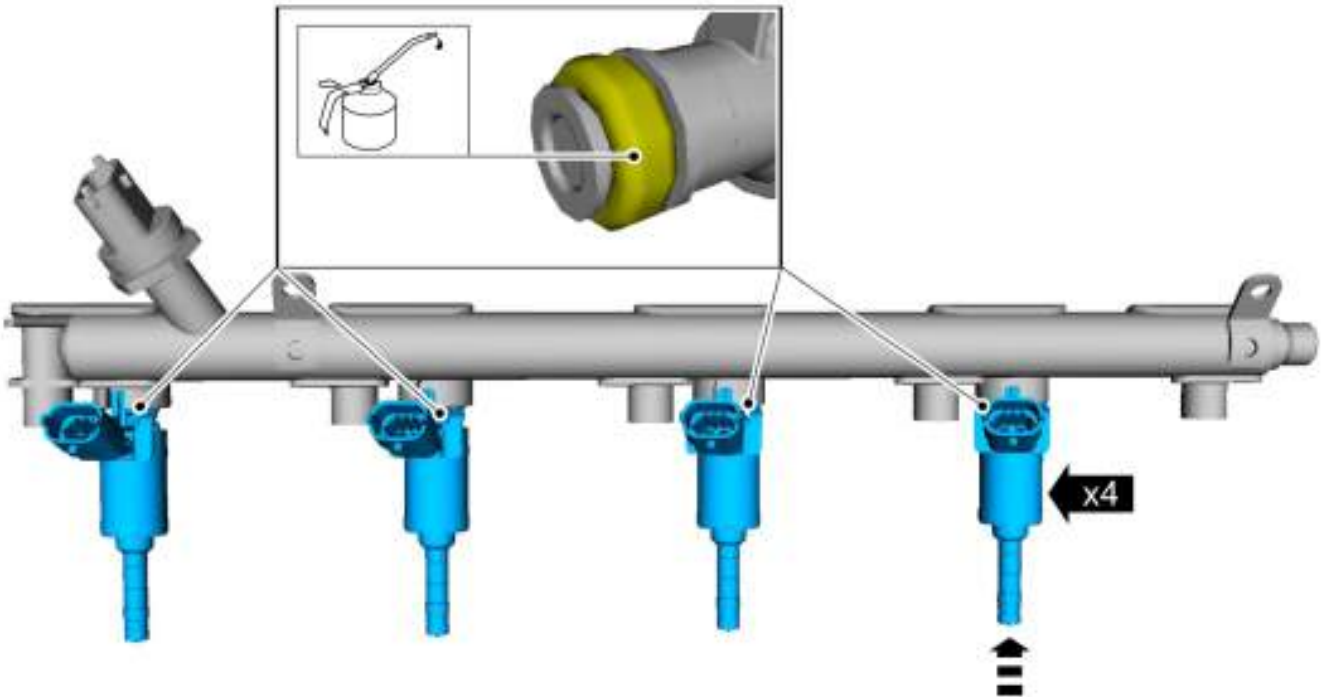

E146968



1. **NOTICE:** Make sure that the component is clean, free of foreign material and lubricant.

**NOTICE:** Take extra care when handling the components.

**NOTE:** *Install all the bolts finger tight before final tightening.*

Tighten each bolt 1 turn at a time.

2. *Torque:*

Stage 1: 71 lb.in (8 Nm)

Stage 2: 26°

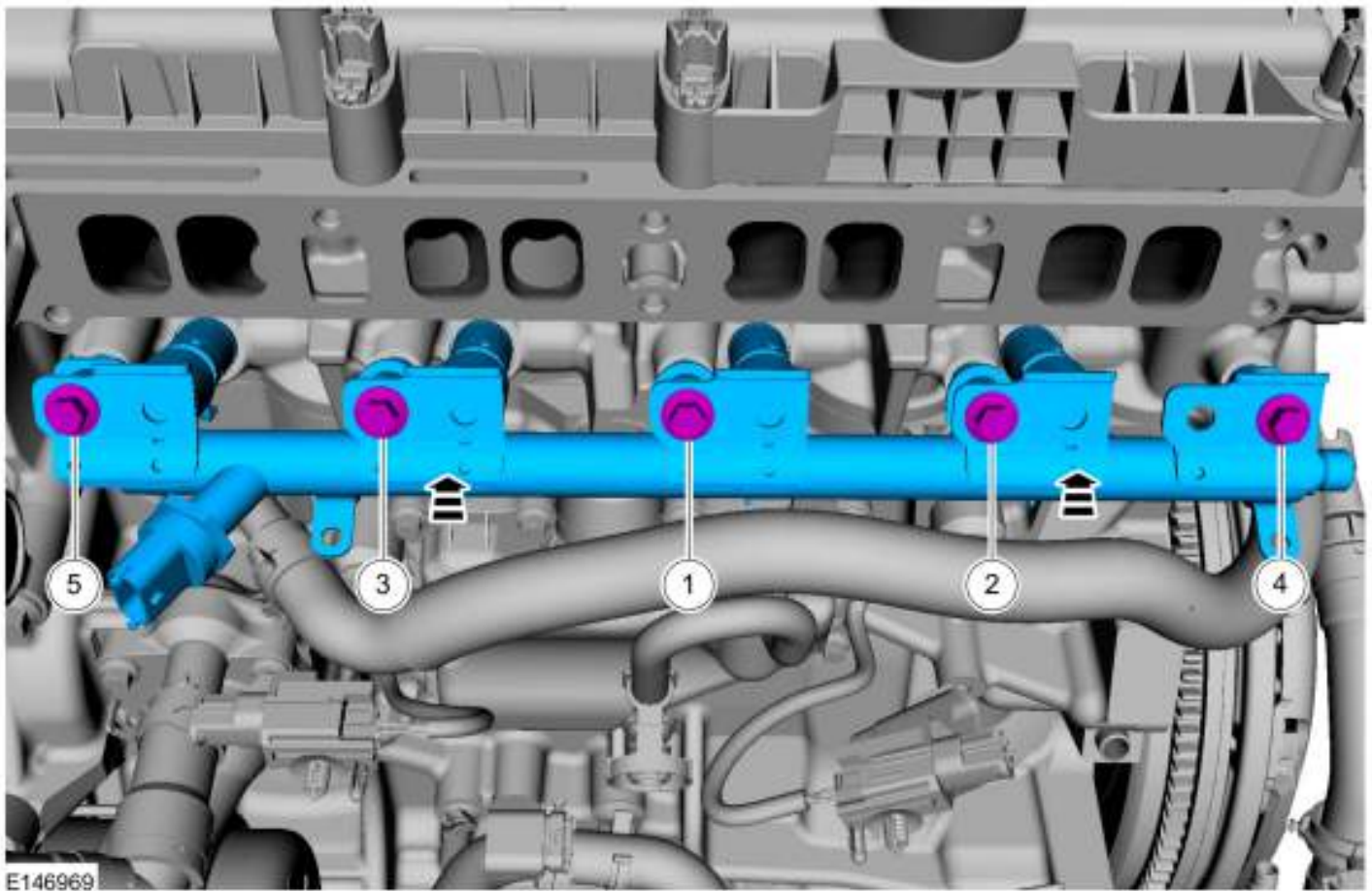

8.

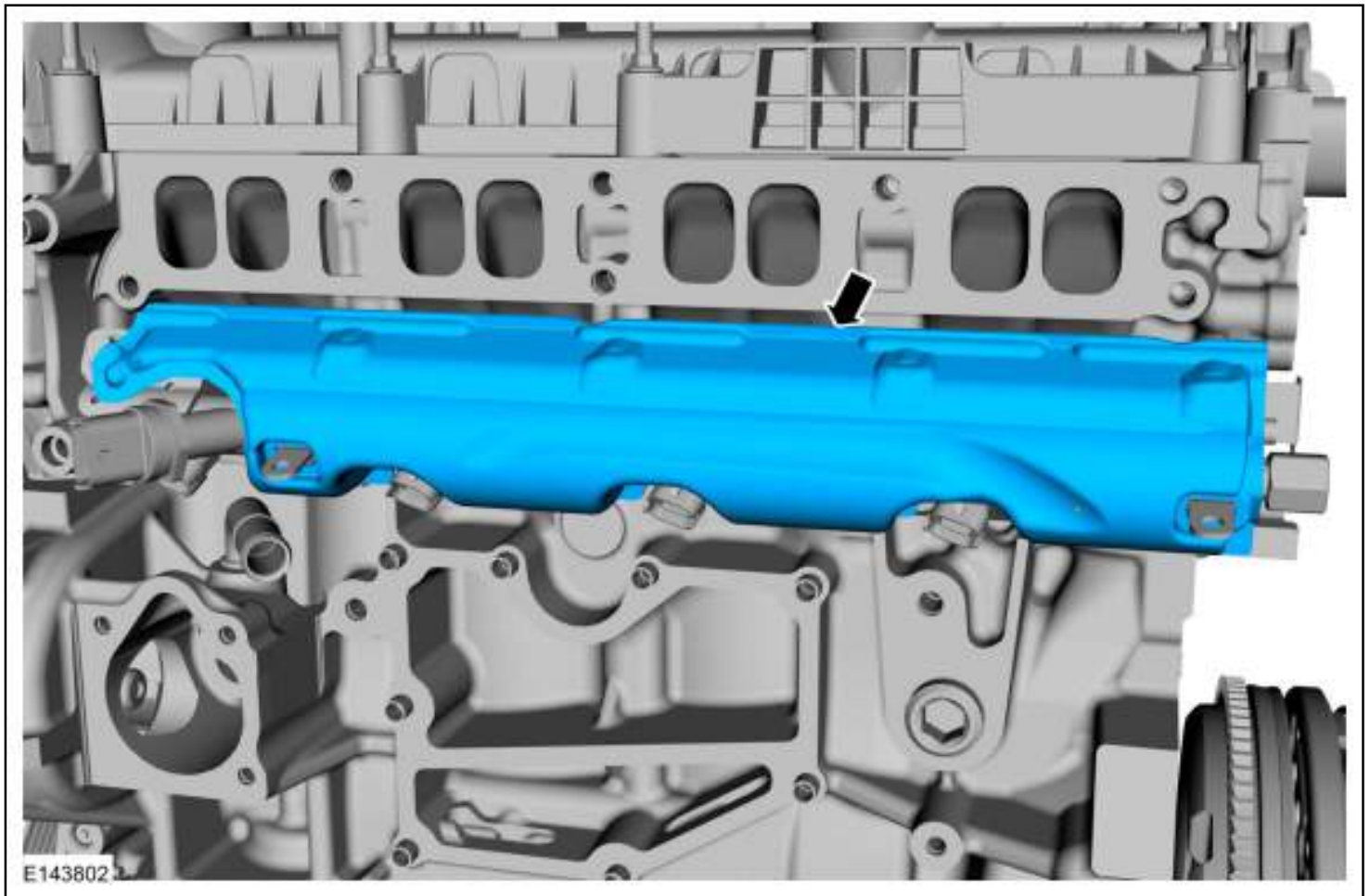

9. Torque: 89 lb.in (10 Nm)

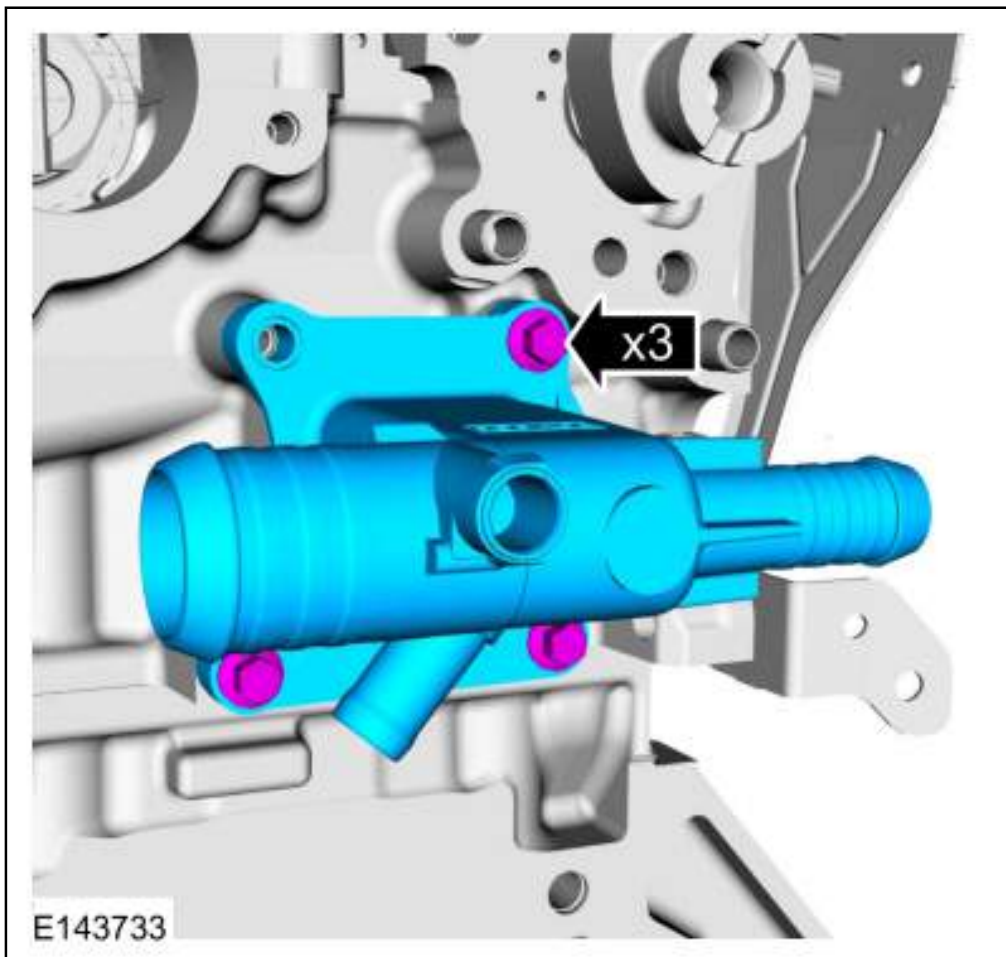

10. *Torque:* 115 lb.in (13 Nm)

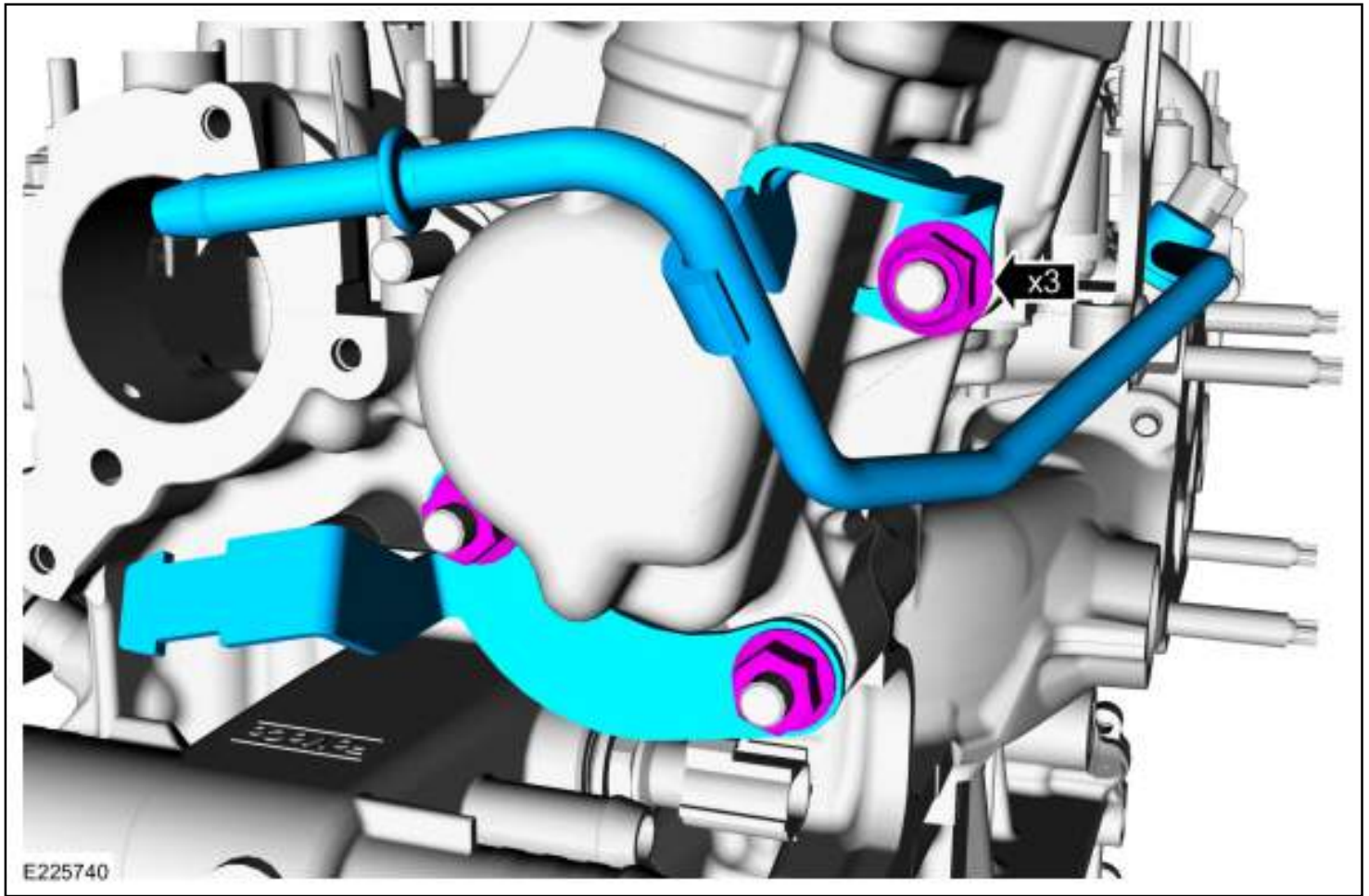

11. **NOTE:** *Make sure that a new component is installed.*

*Torque:* 97 lb.in (11 Nm)

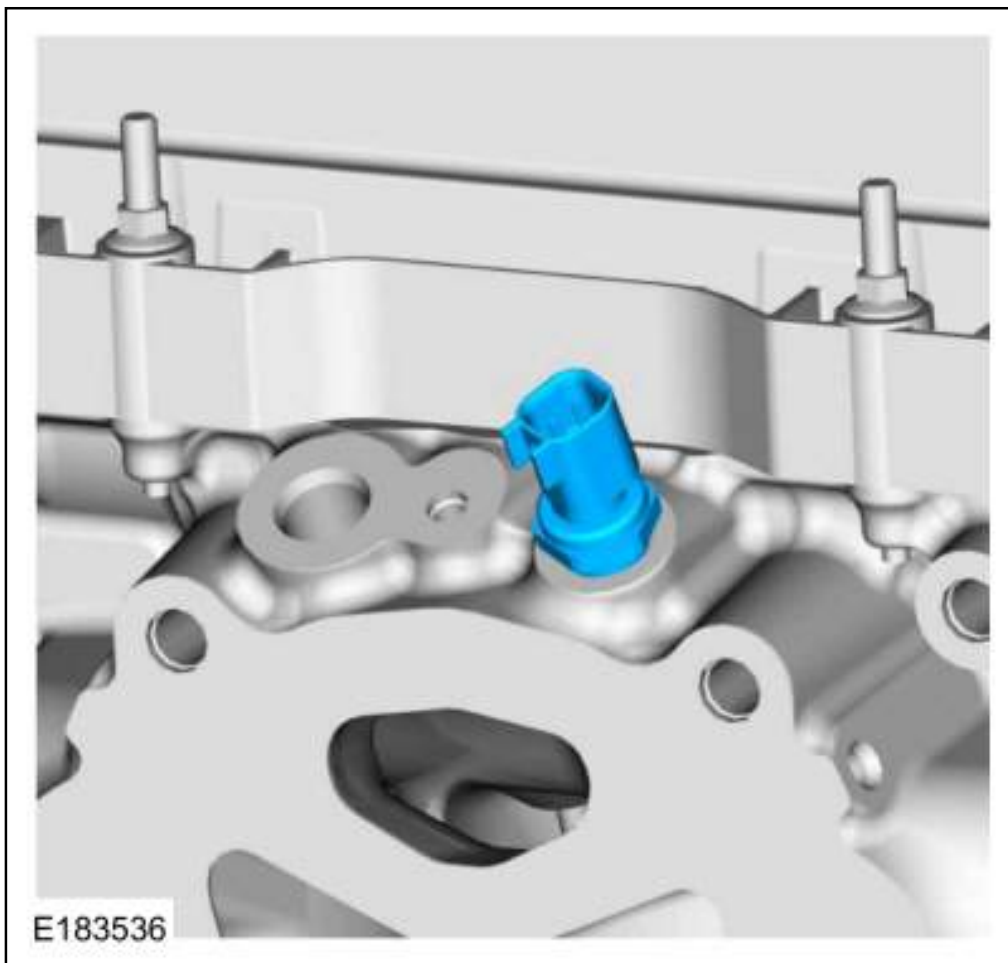

12. *Torque:* 89 lb.in (10 Nm)

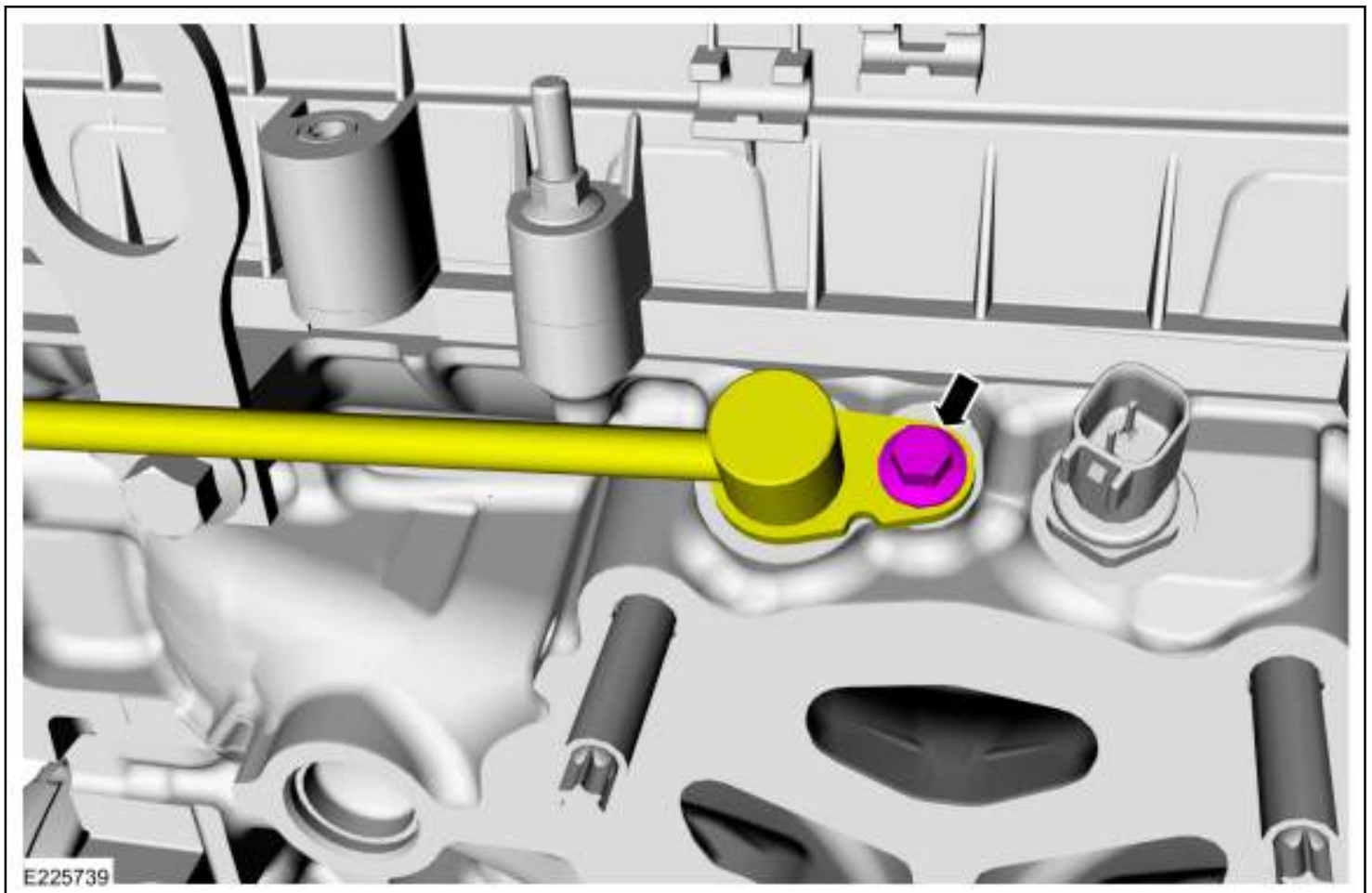

13.

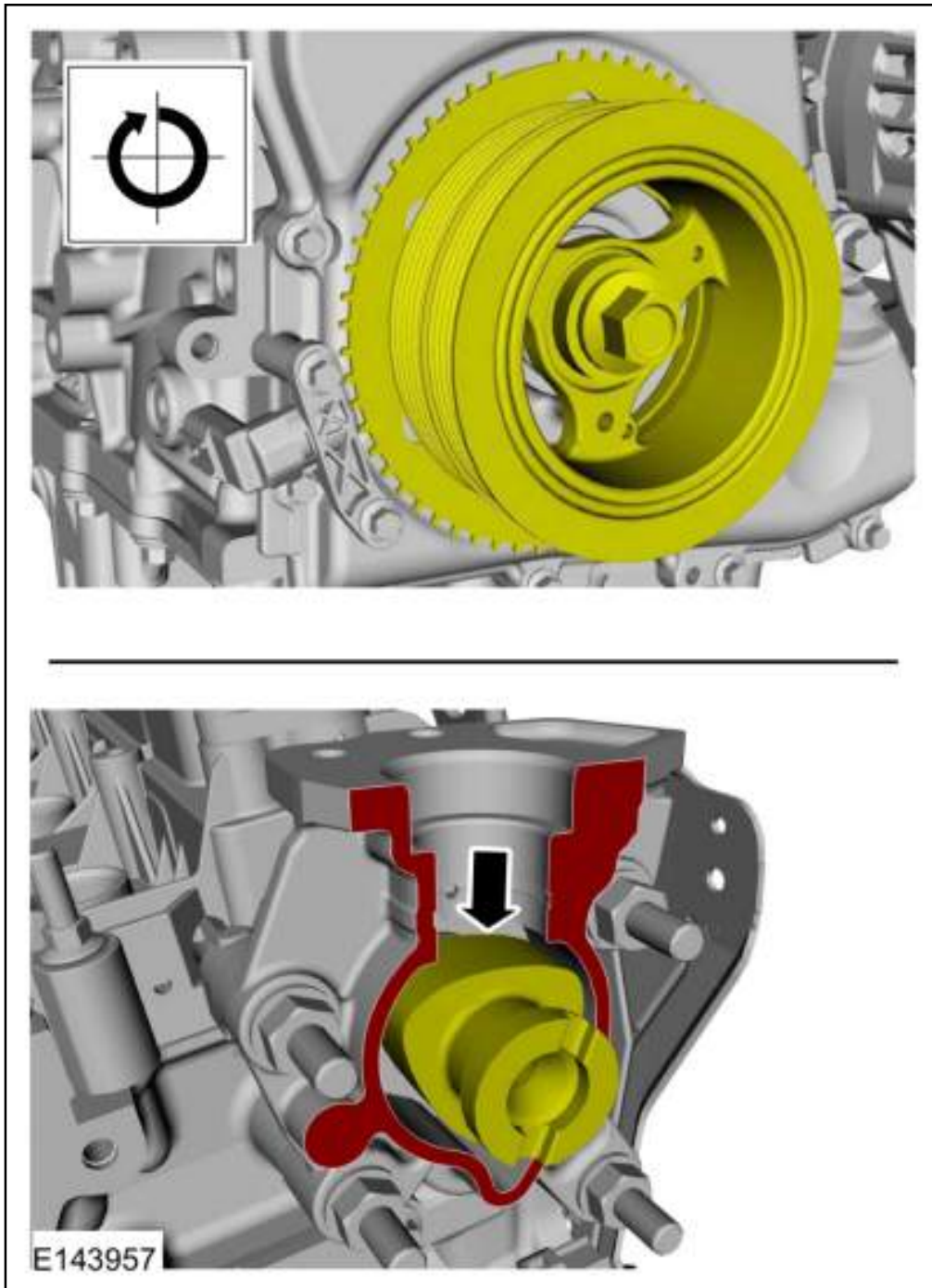

14. *Material:* Engine Oil - SAE 0W-40 (WSS-M2C937-A)

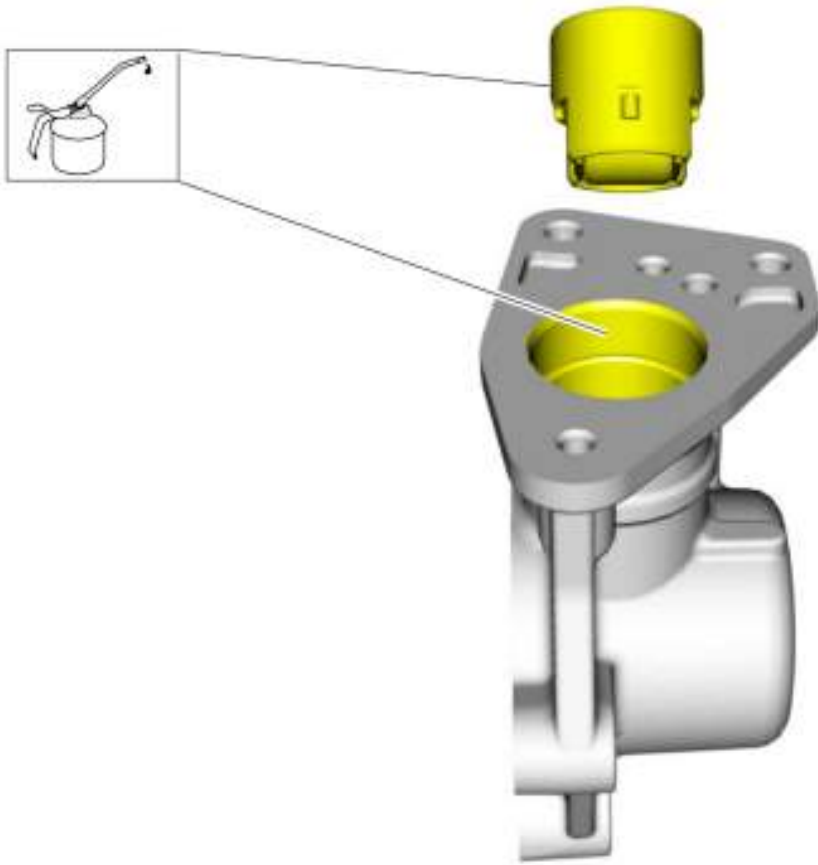

E175708

15.



E174230



16. *Material:* Engine Oil - SAE 0W-40 (WSS-M2C937-A)

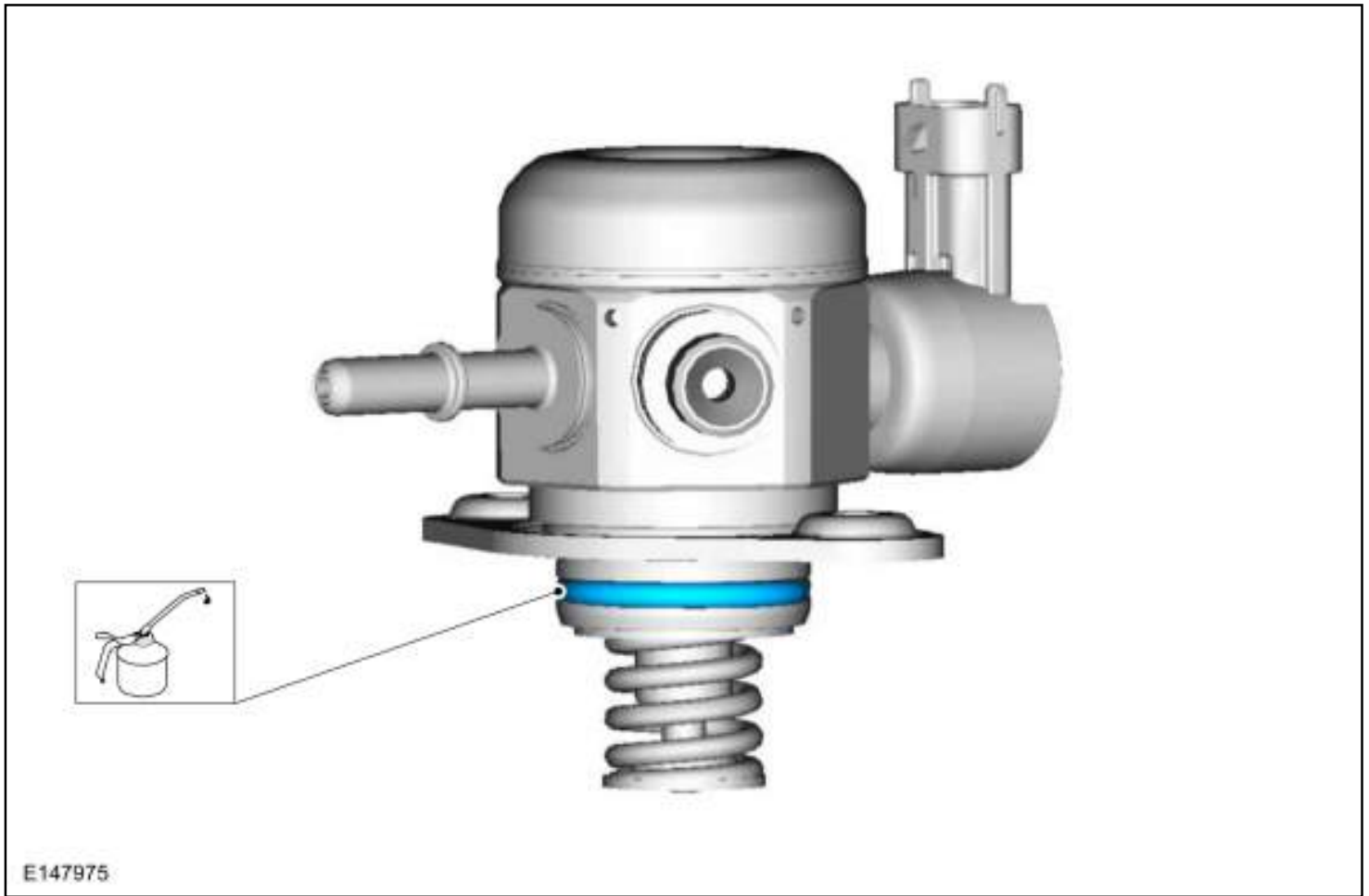

17. Tighten each bolt 0.5 turn at a time, until the components are in full contact, before final tightening.

*Torque:*

Stage 1: 44 lb.in (5 Nm)

Stage 2: 55°



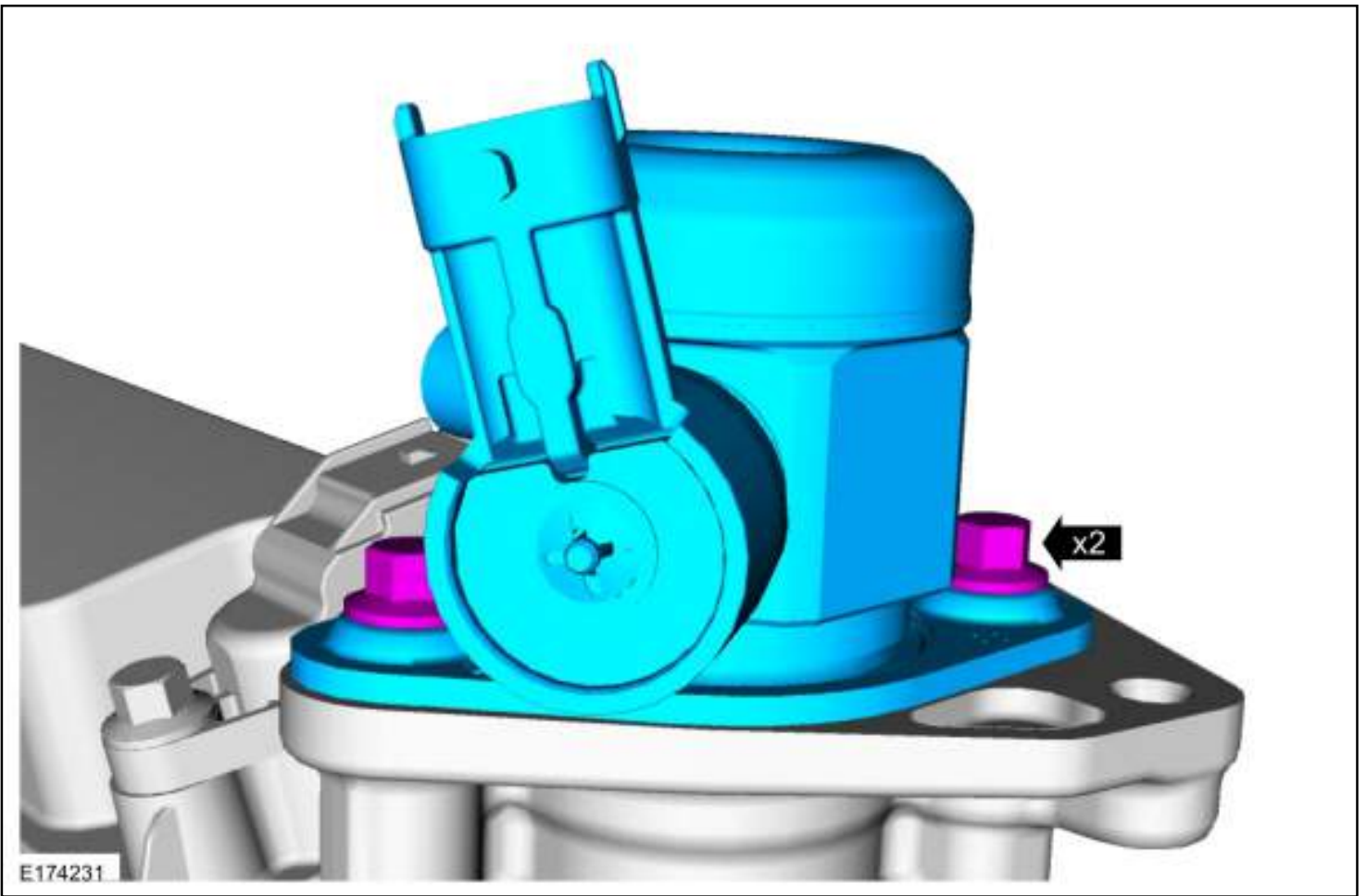

18. *Torque: 150 lb.in (17 Nm)*

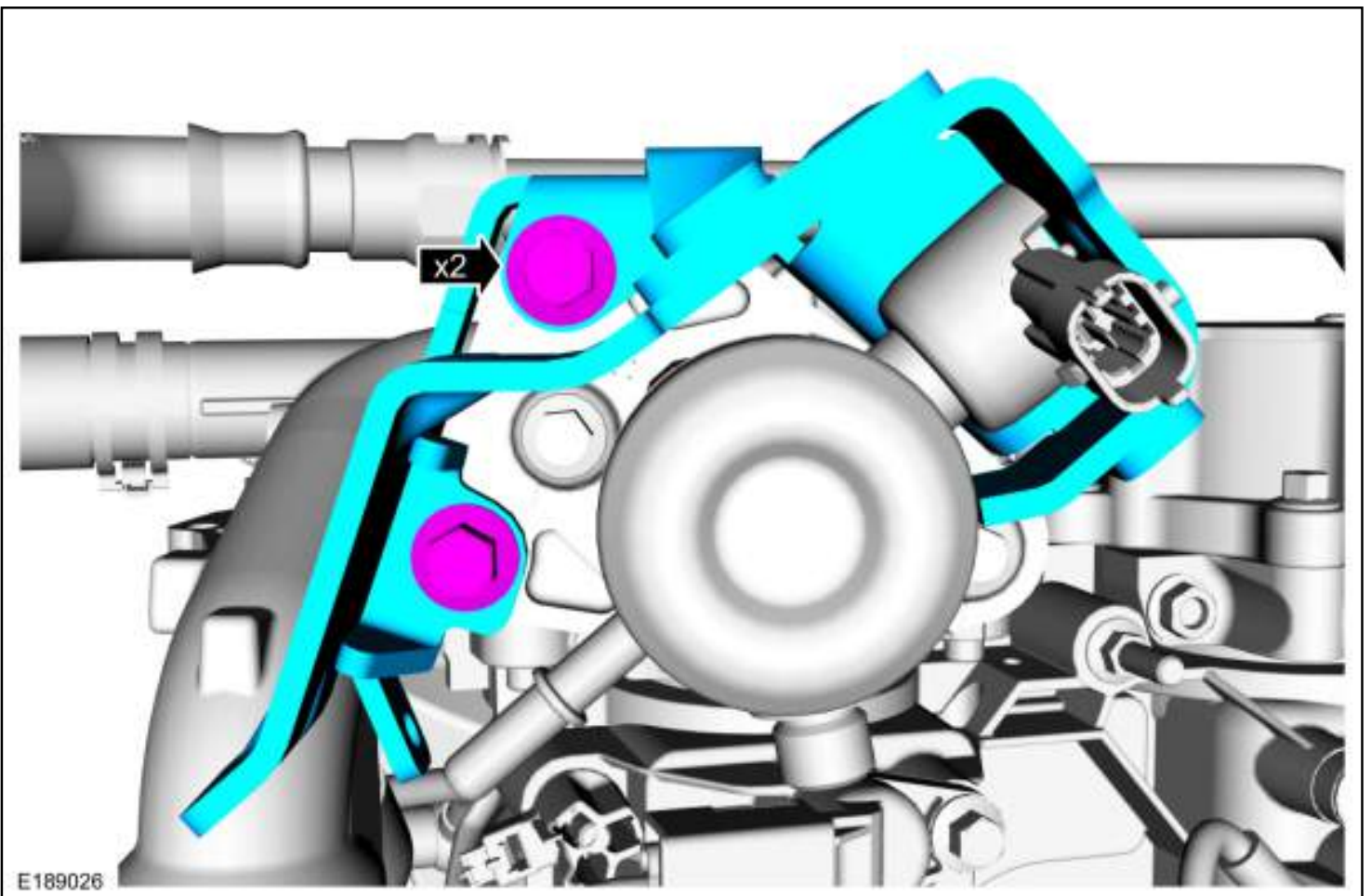

19. **NOTE:** Make sure that a new component is installed.

**NOTE:** Only tighten the nuts and bolts finger tight at this stage.

1. **Torque:**  
Stage 1: 133 lb.in (15 Nm)  
Stage 2: 30°
2. **Torque:** 150 lb.in (17 Nm)
3. **Torque:** 89 lb.in (10 Nm)

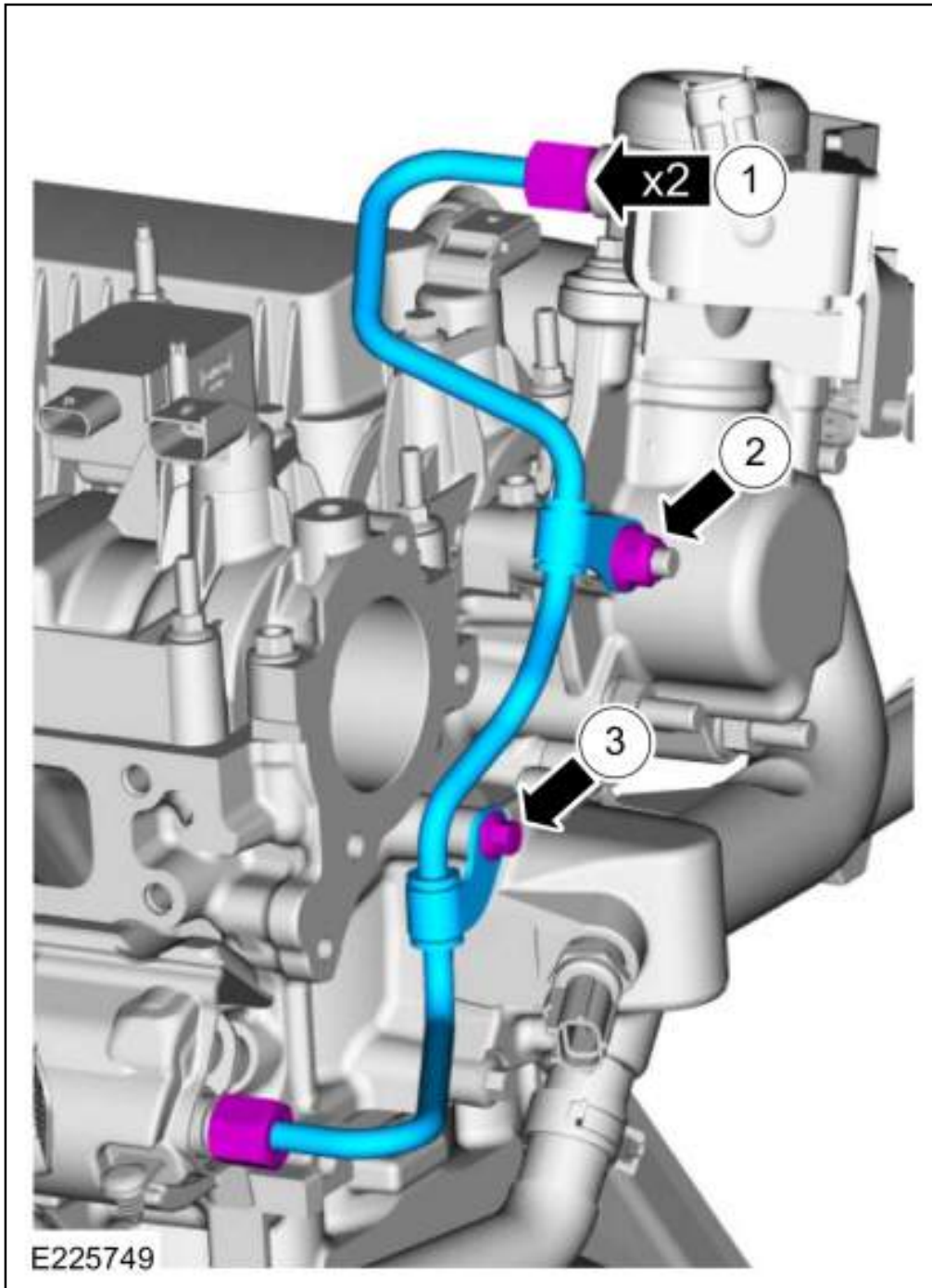

cardiagn.com

21. **Torque:** 89 lb.in (10 Nm)

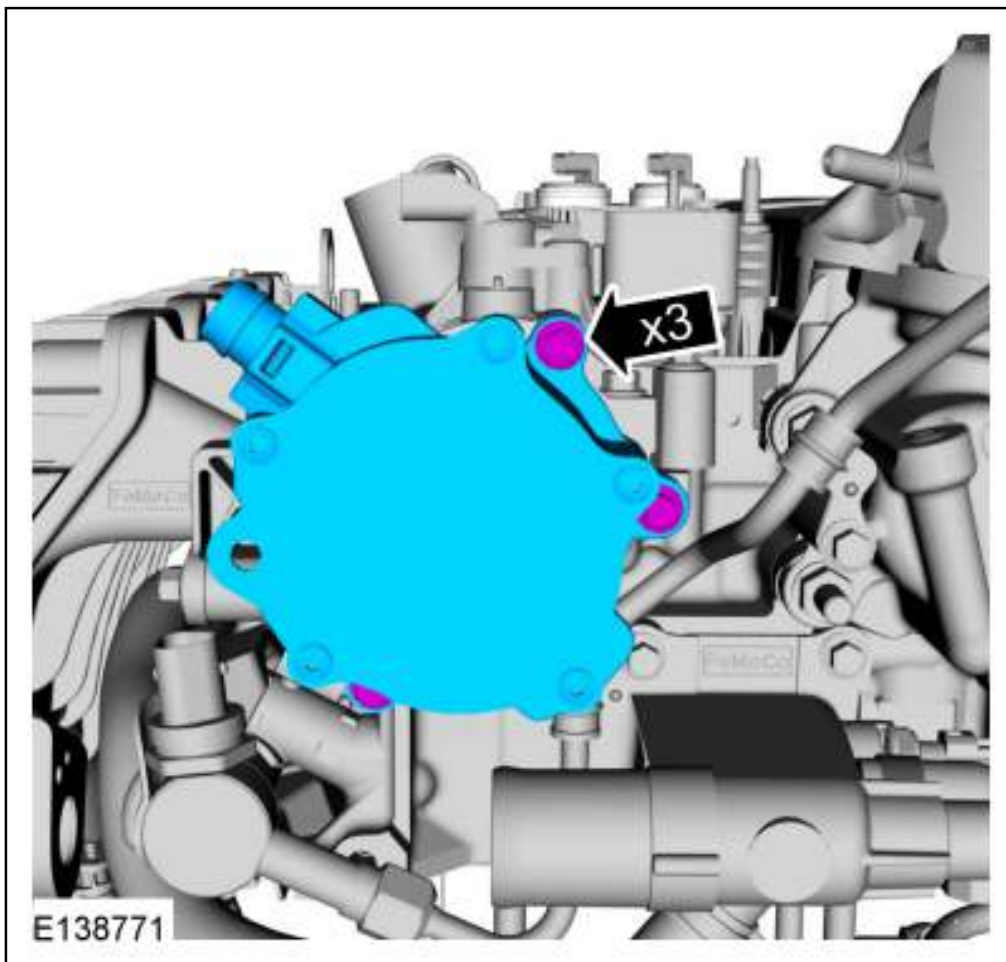

1. *Torque:* 18 lb.ft (24 Nm)
2. *Torque:* 177 lb.in (20 Nm)
3. *Torque:* 18 lb.ft (24 Nm)
4. *Torque:* 18 lb.ft (24 Nm)
5. *Torque:* 18 lb.ft (24 Nm)

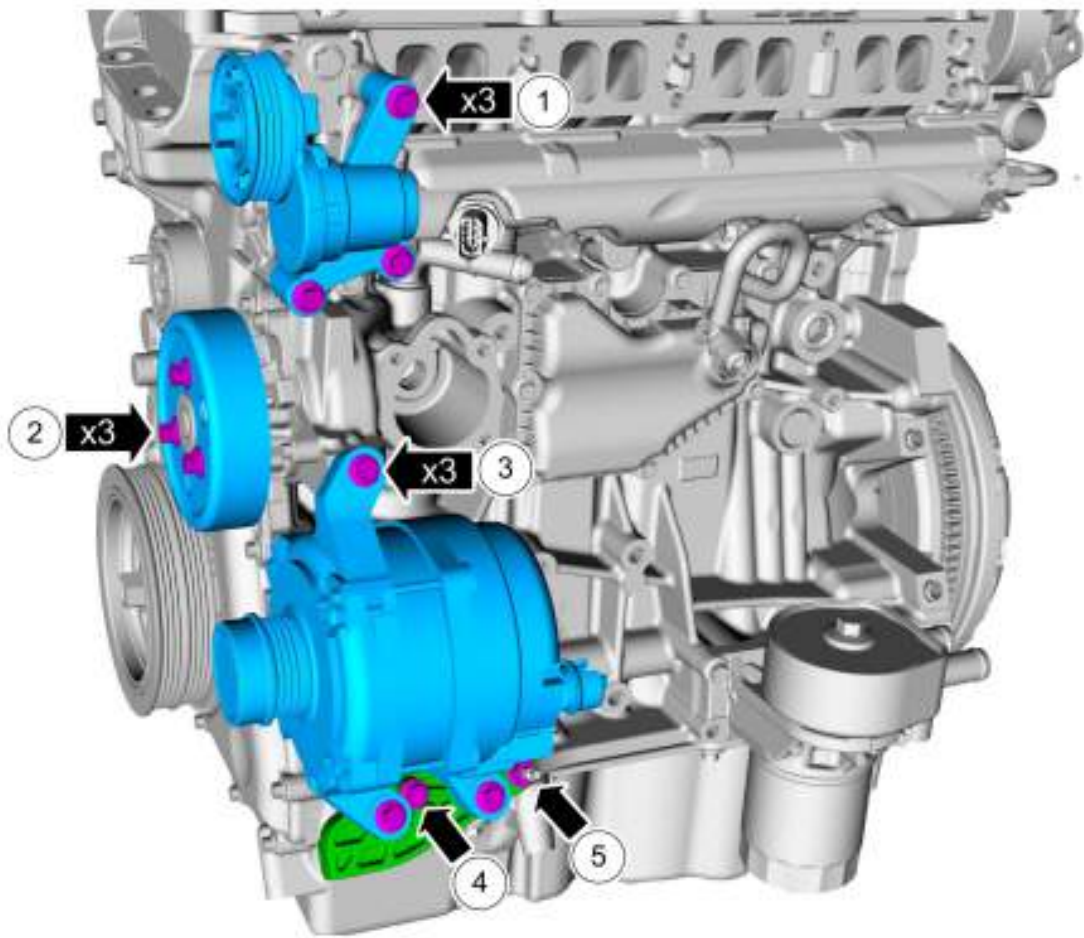

E225755

23. Torque: 177 lb.in (20 Nm)

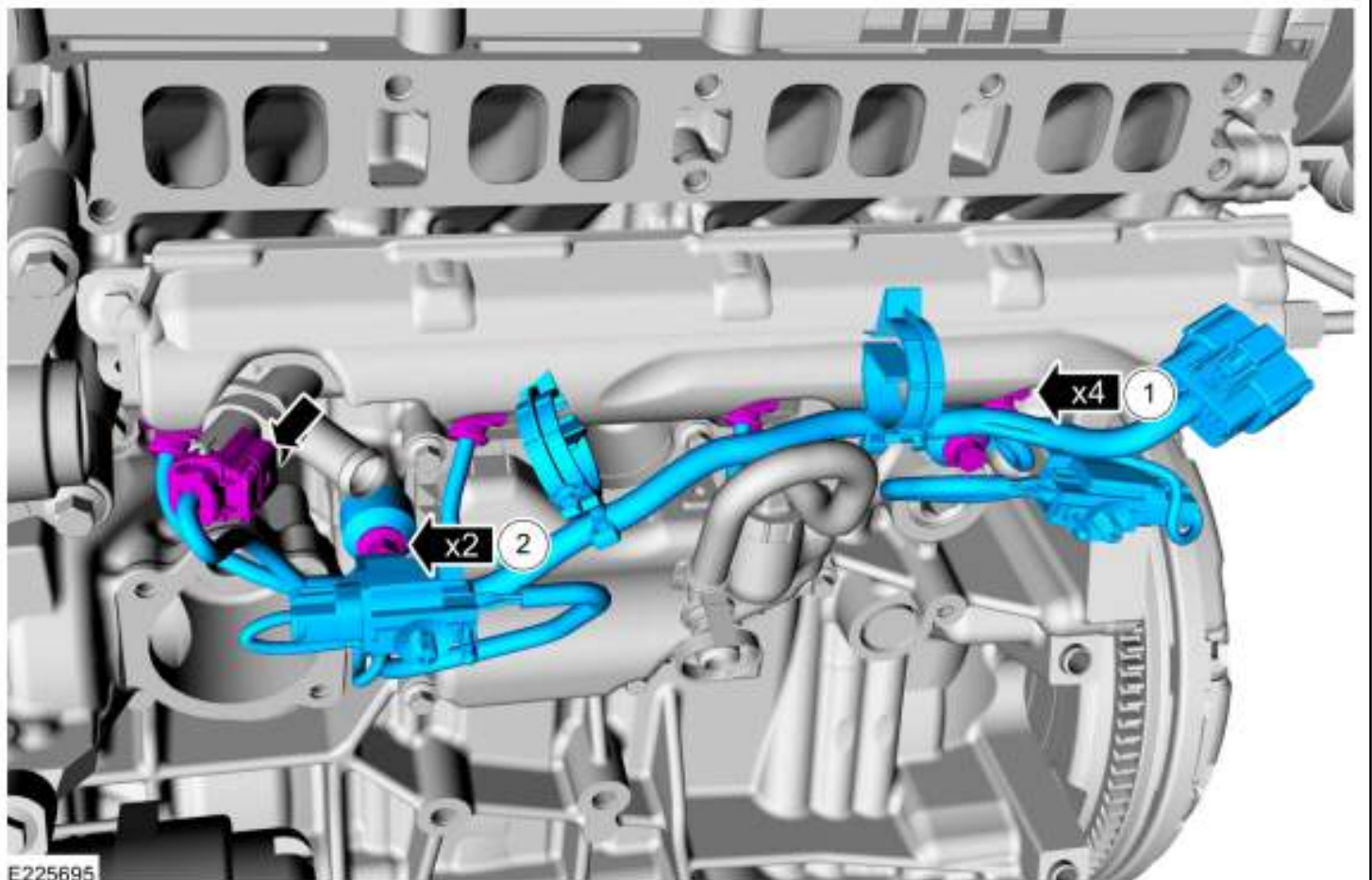

E225695



cardiagn.



1. Use the General Equipment: Hose Clamp Remover/Installer
2. *Torque*: 89 lb.in (10 Nm)

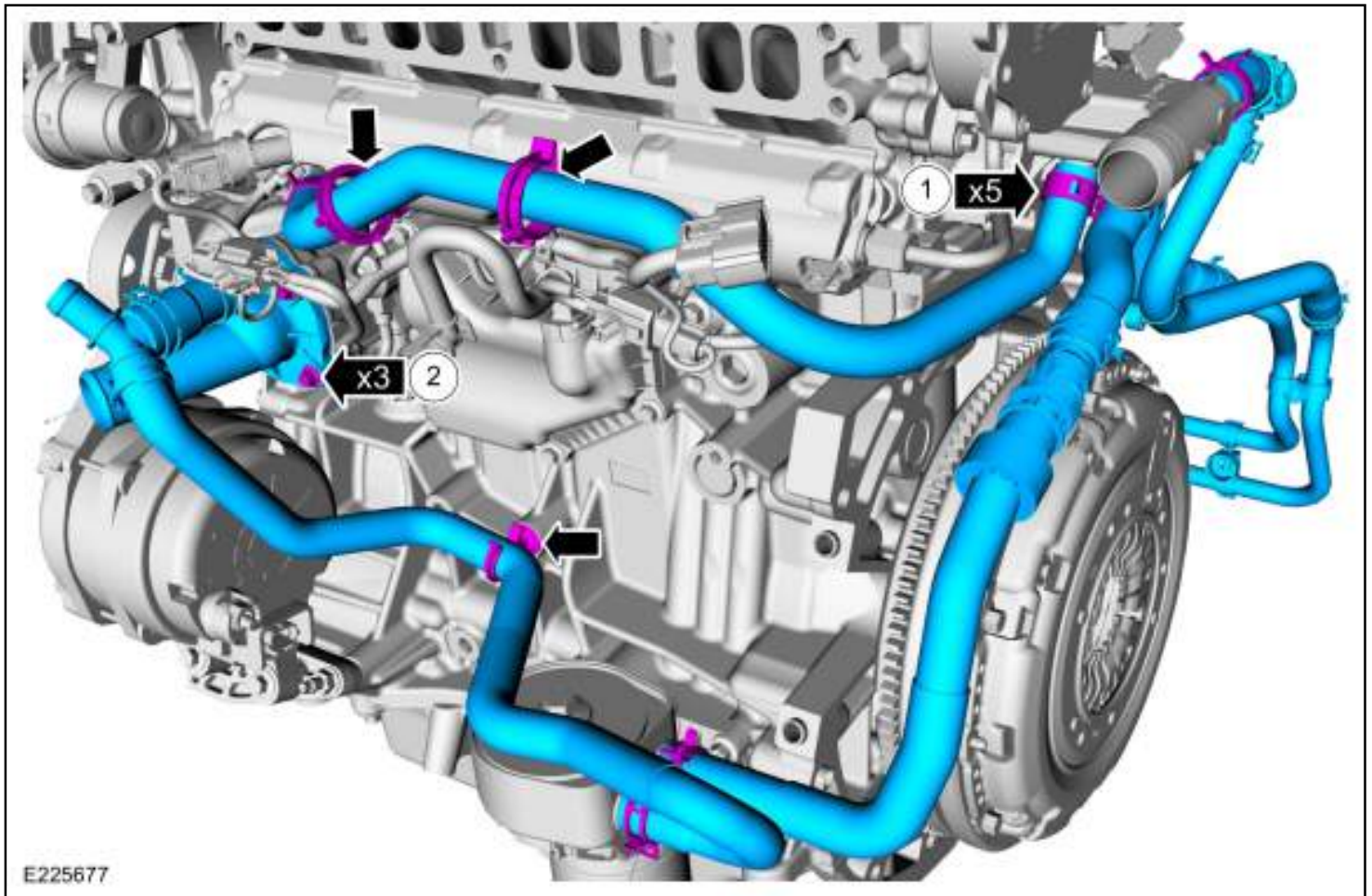

25. *Torque*: 177 lb.in (20 Nm)

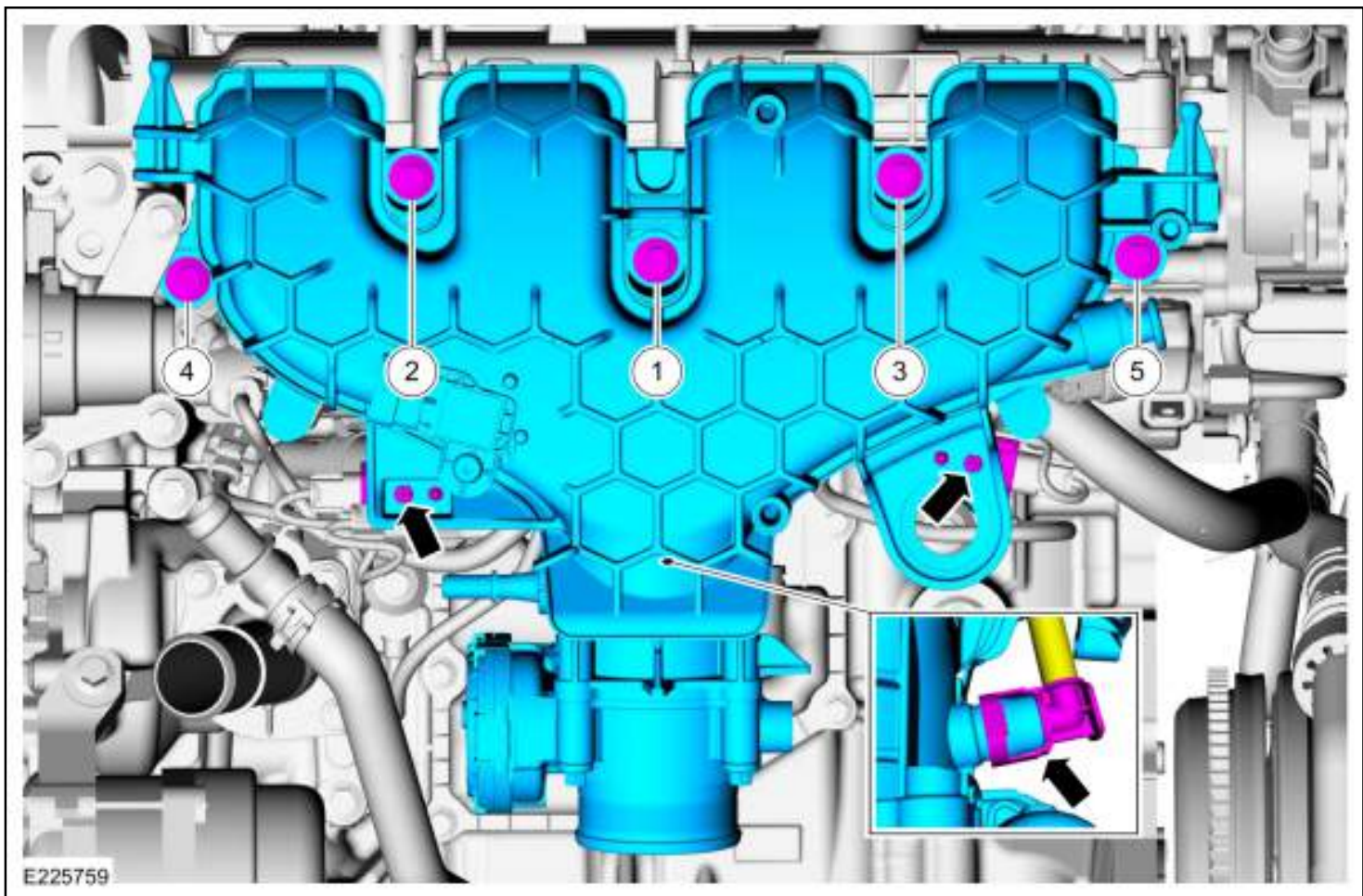

26.

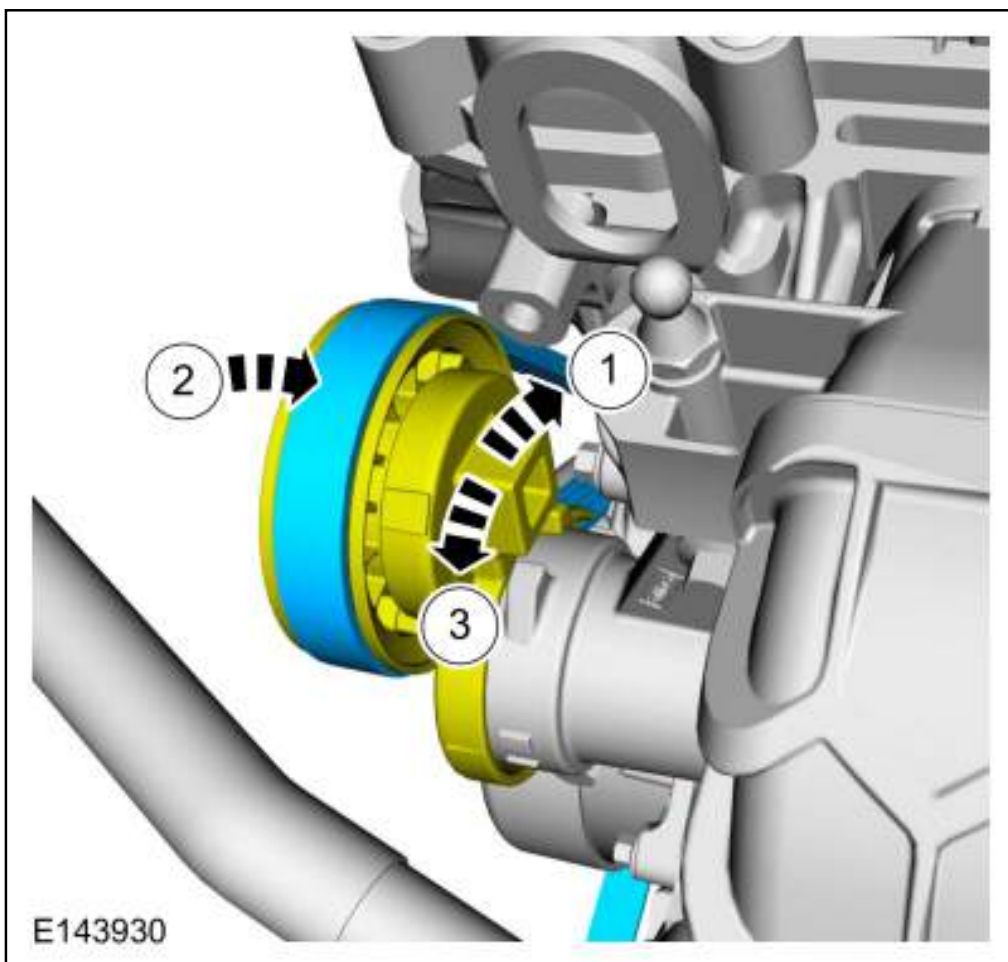

27. Torque: 71 lb.in (8 Nm)

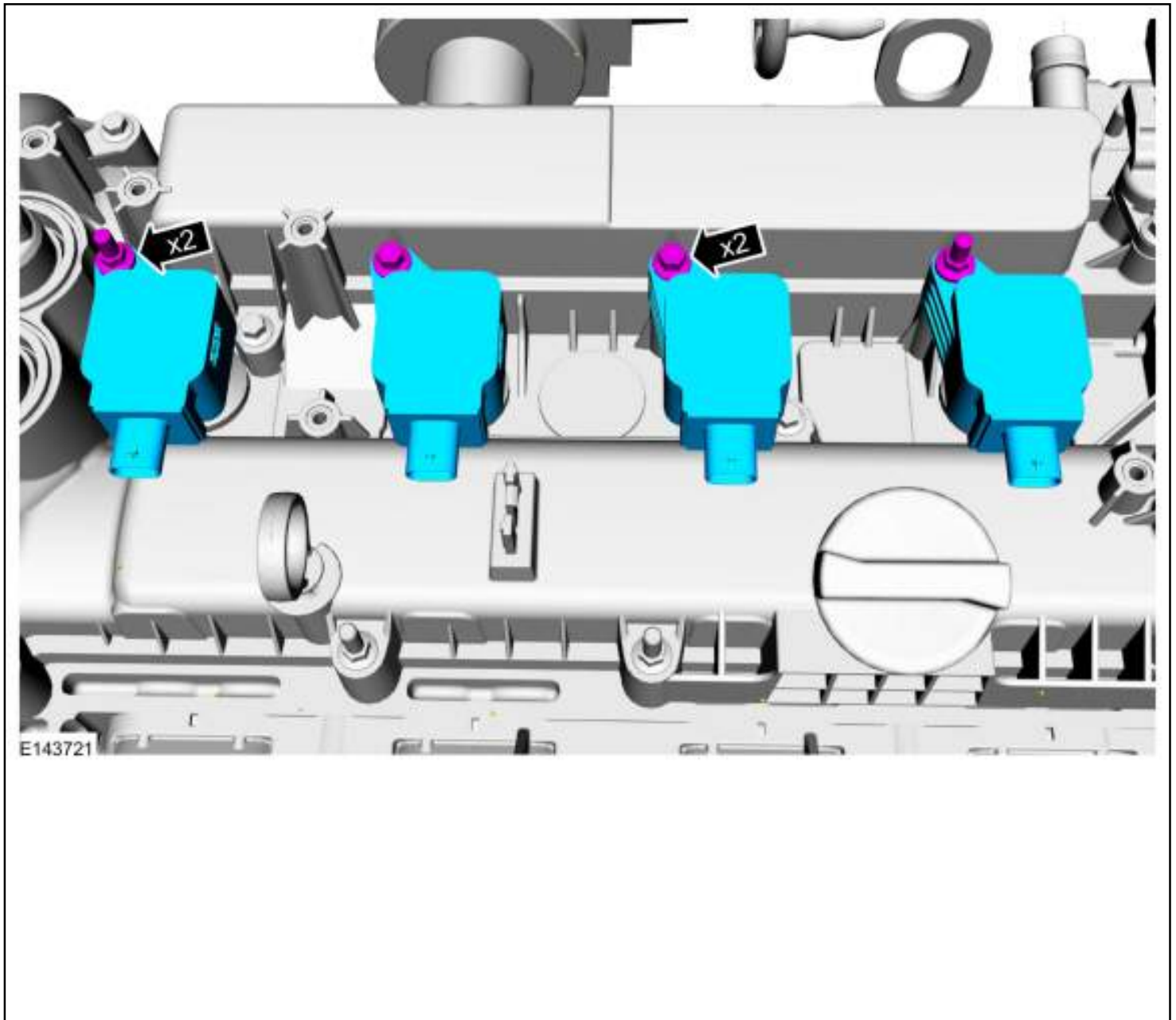

28.

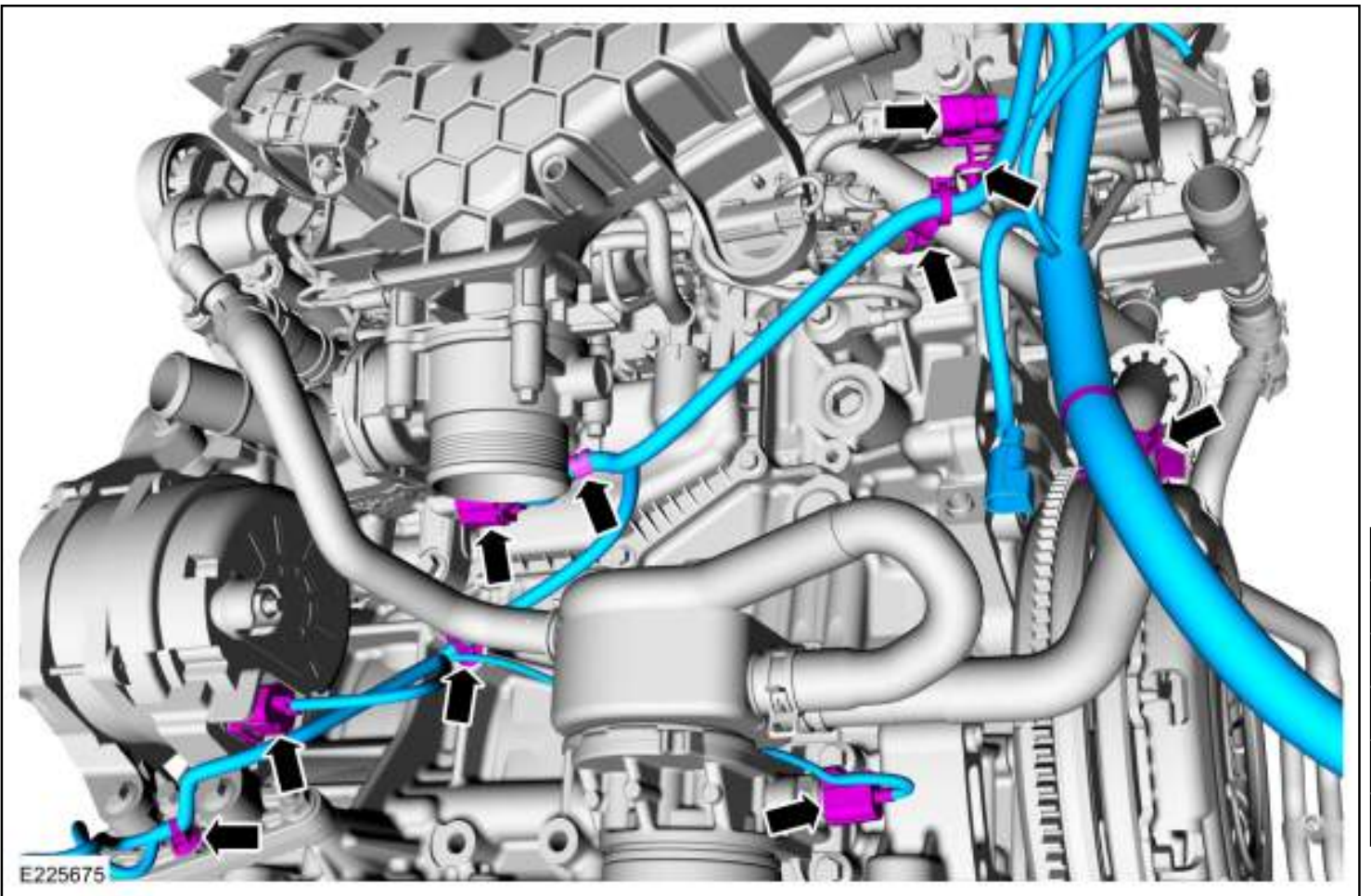

29.

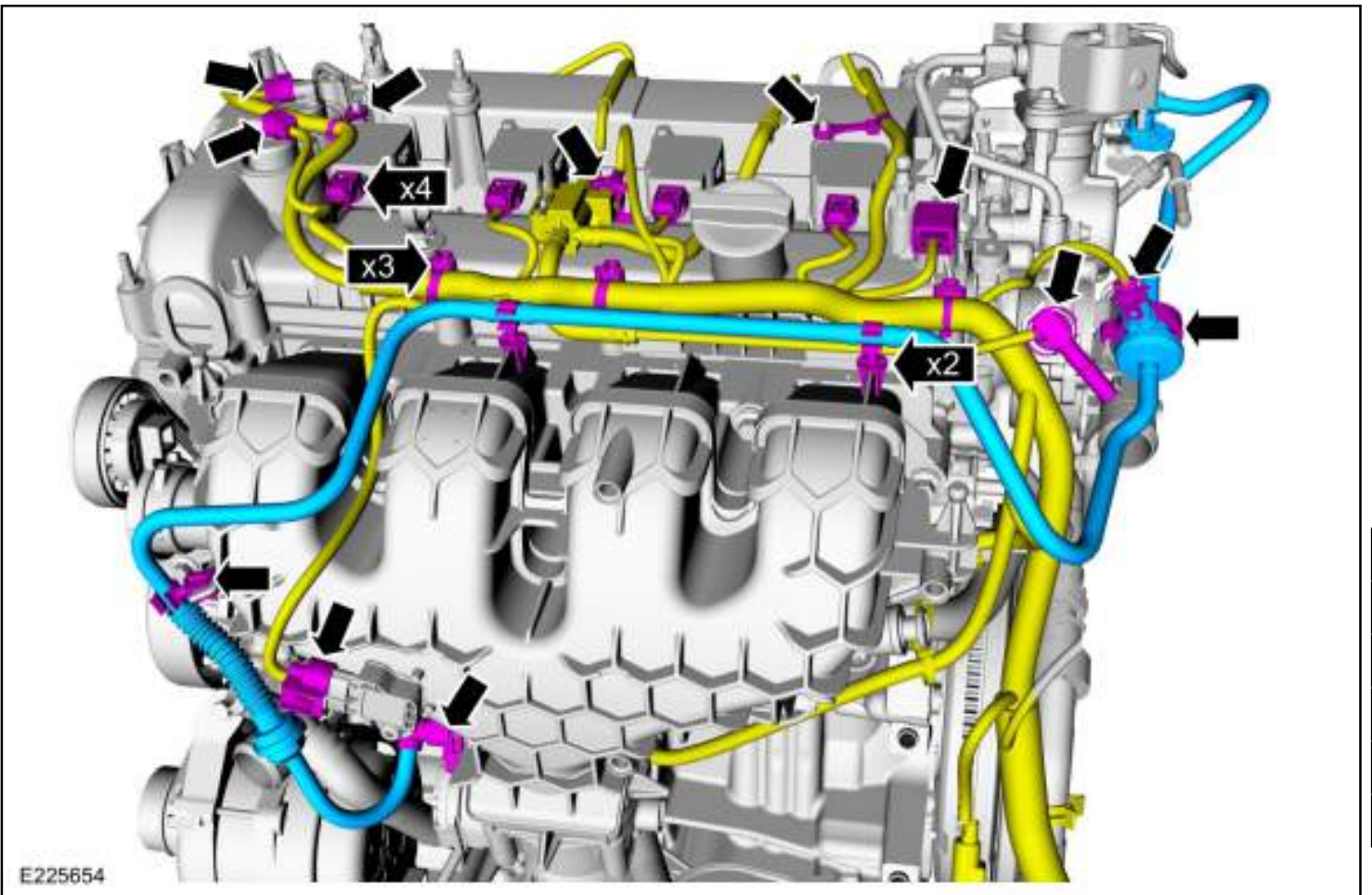

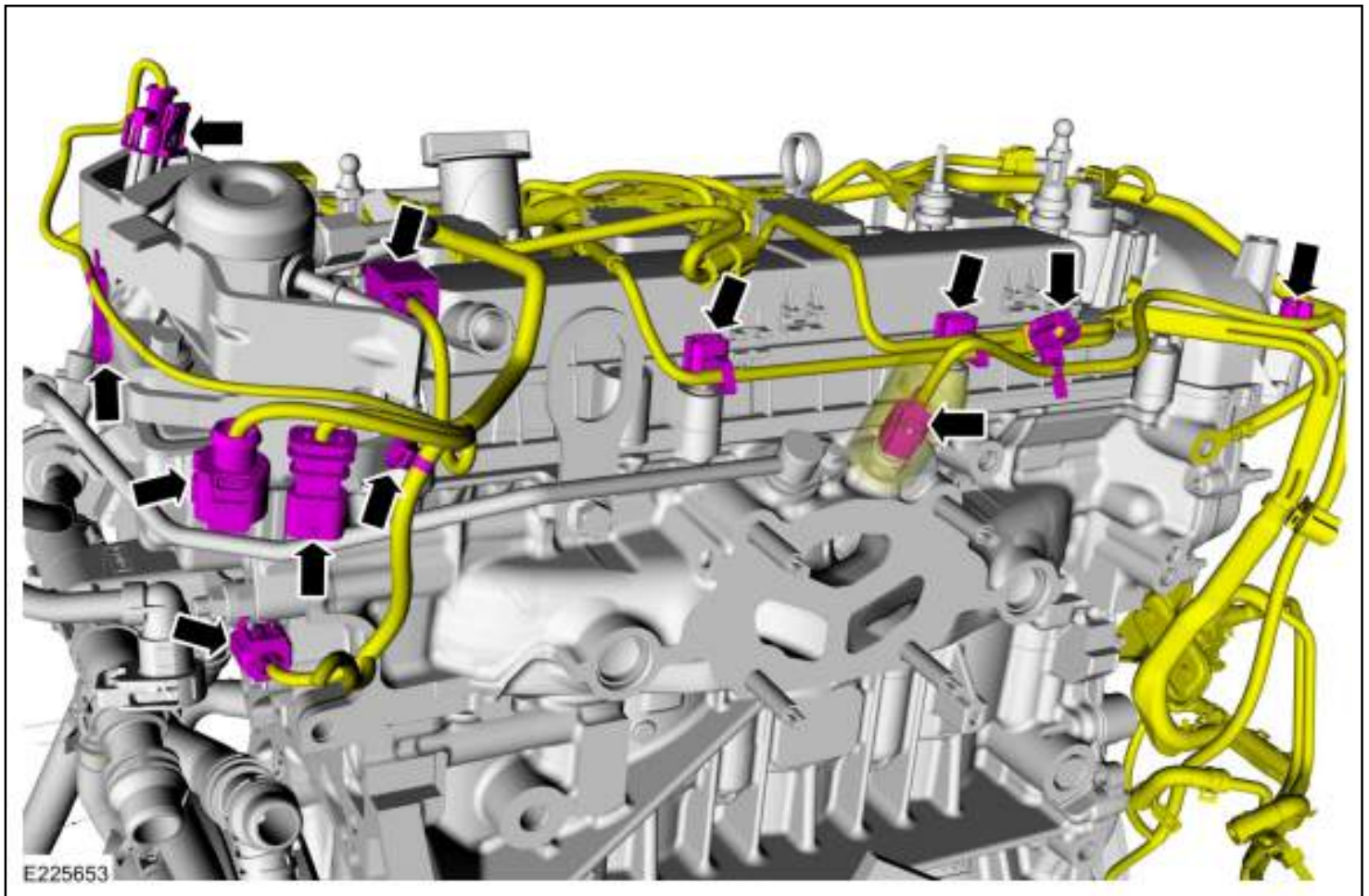

1. *Torque:* 177 lb.in (20 Nm)
2. *Torque:* 89 lb.in (10 Nm)

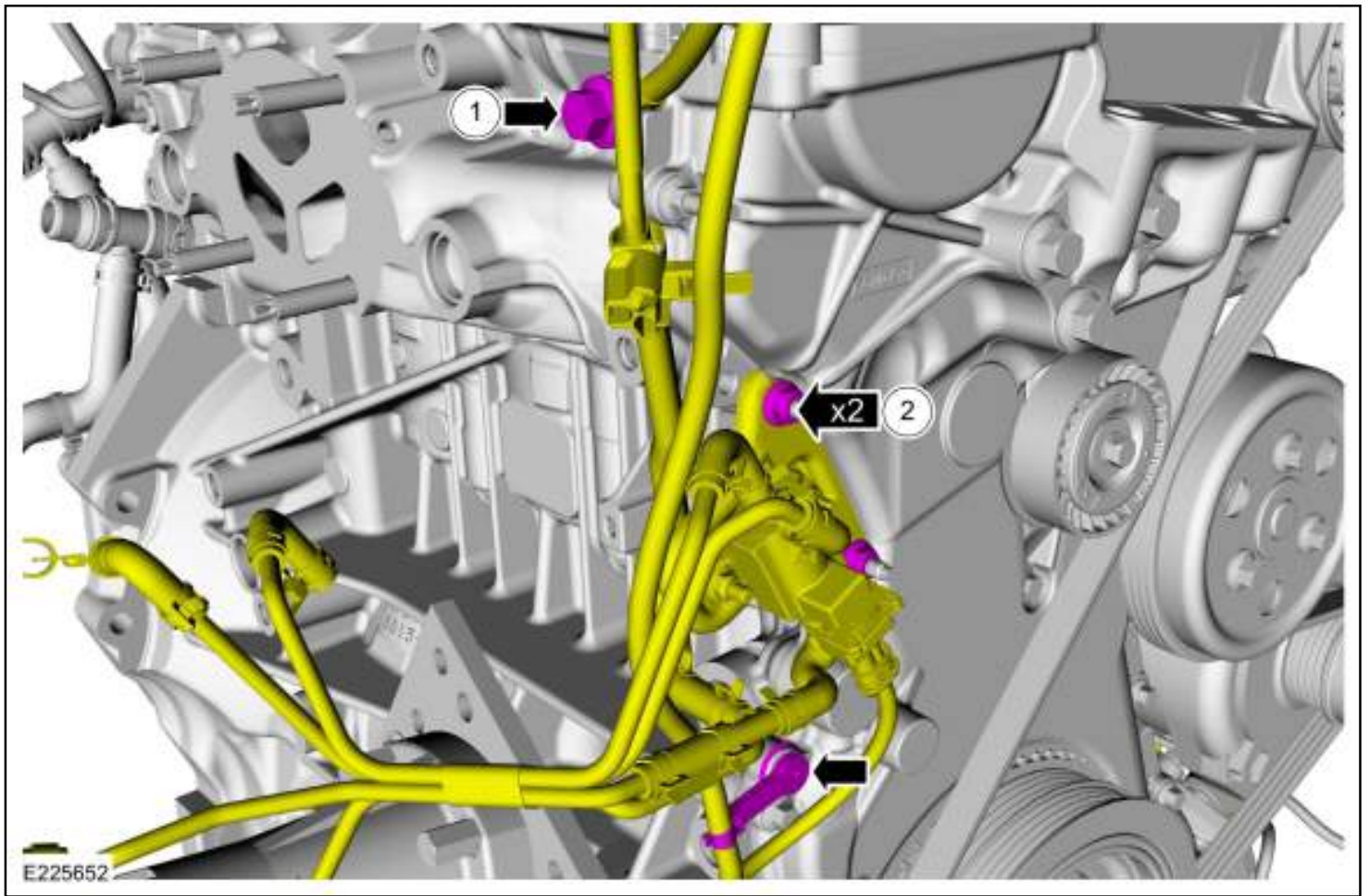

32.

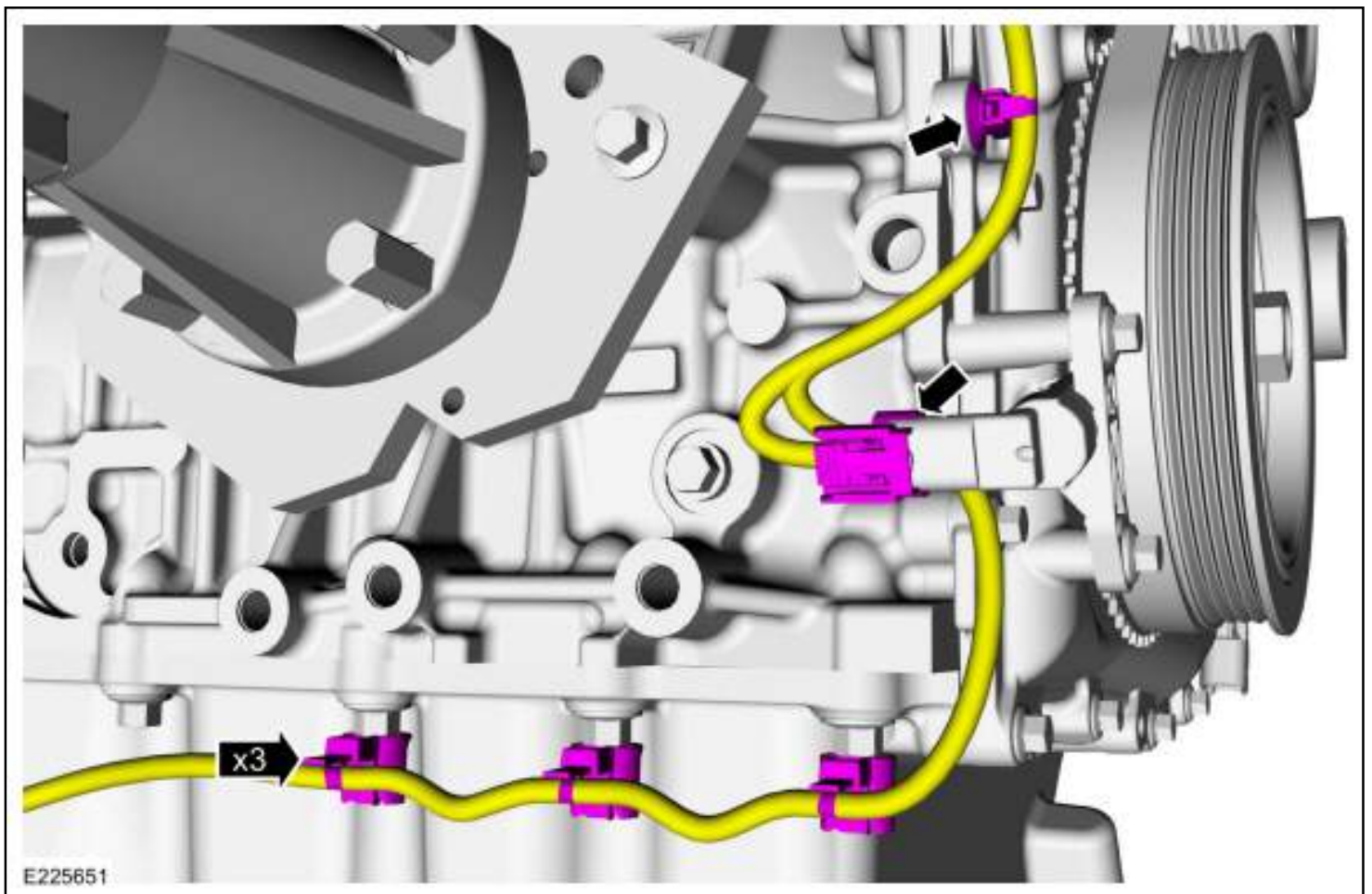

33. Refer to: [Crankshaft Position \(CKP\) Sensor](#) (303-14D Electronic Engine Controls - 2.3L EcoBoost (257kW/350PS) - MI4, Removal and Installation).

34. Install the following items:

- Use the General Equipment: Lifting Bracket
- Use the General Equipment: Floor Crane

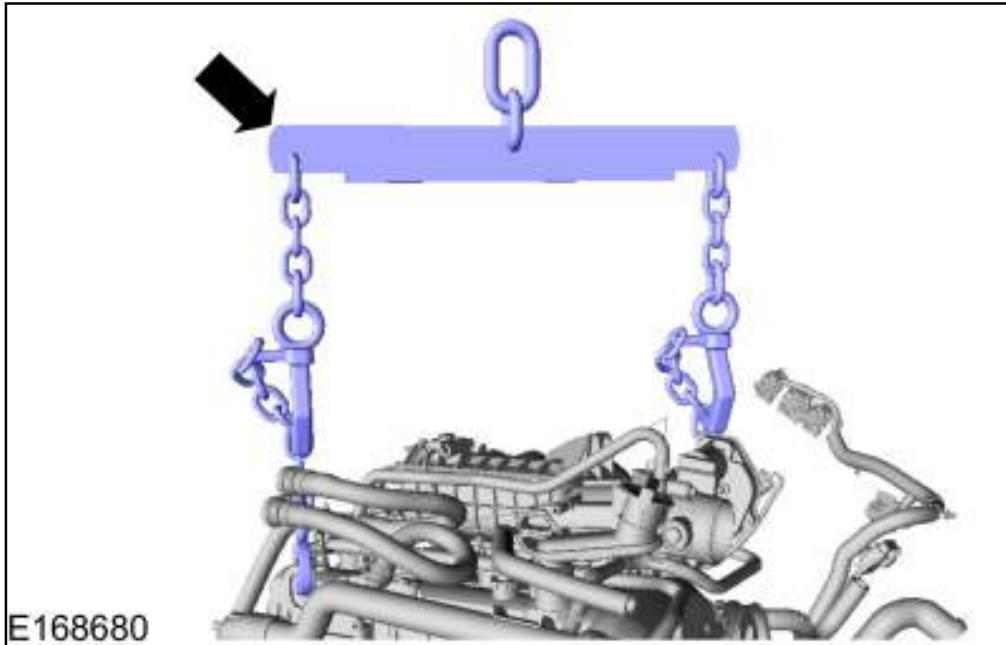

35. Remove Special Service Tool: 303-435 Mounting Stand. , 303-435-11B Mounting Plate for 303-435-06. , 303-435-06 Mounting Bracket for 303-435.

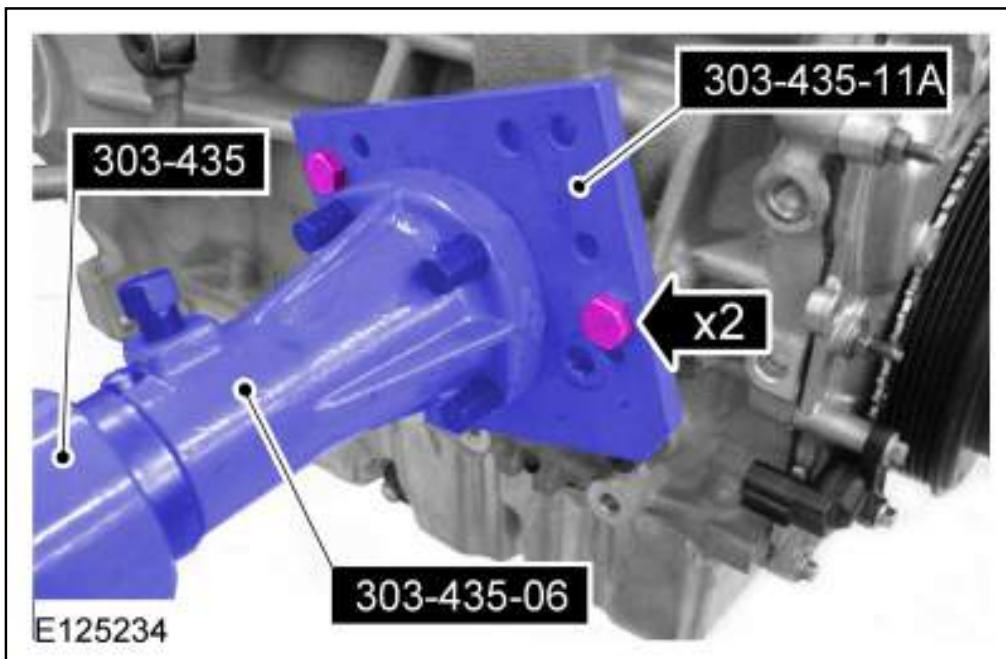

1. Use the General Equipment: Hose Clamp Remover/Installer
2. **NOTE:** Use new seals.

*Torque: 27 lb.ft (37 Nm)*

3. *Torque: 37 lb.ft (50 Nm)*

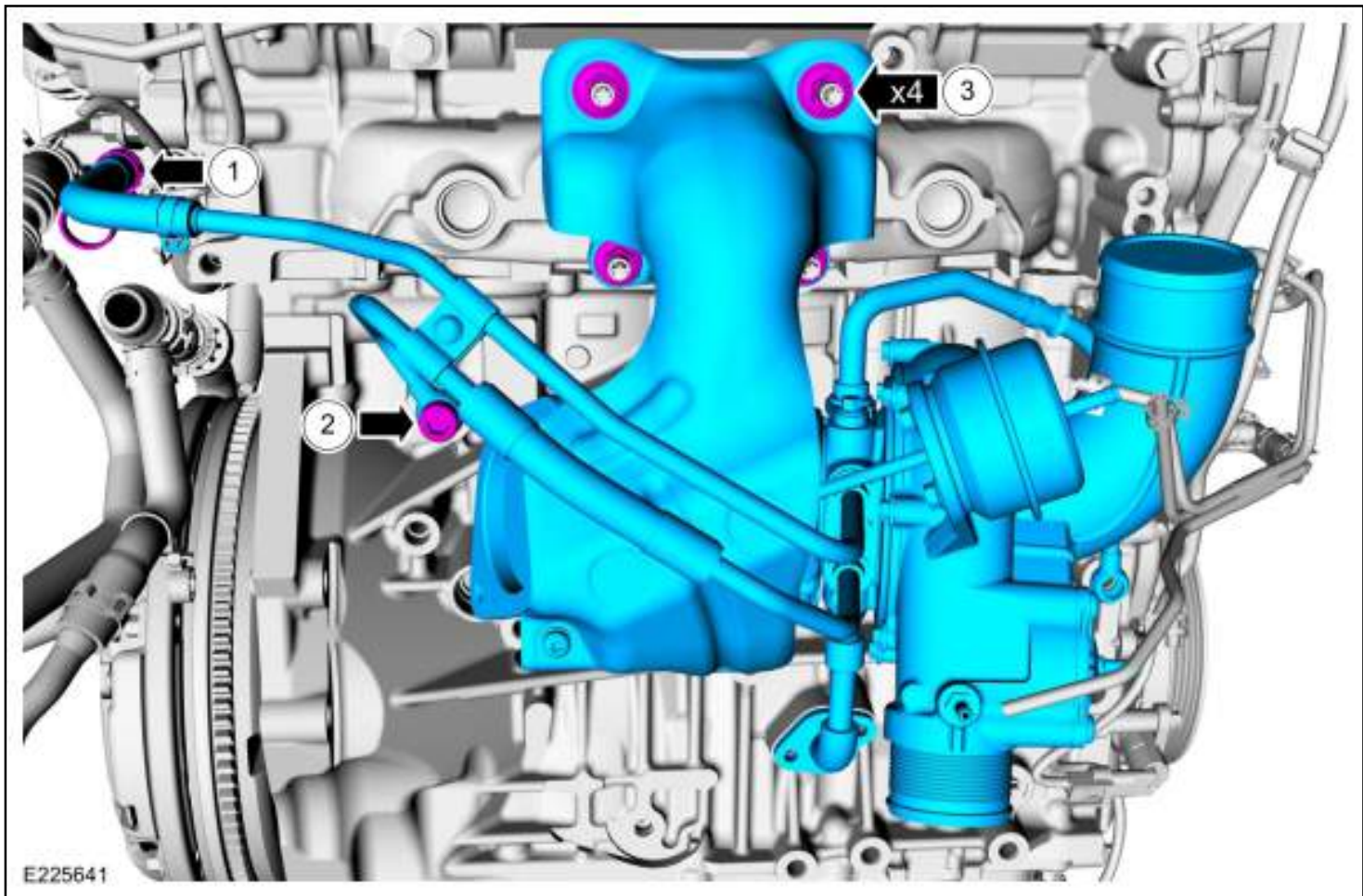

1. Use the General Equipment: Hose Clamp Remover/Installer
2. **NOTE:** *Make sure that a new O-ring seal is installed.*

*Torque: 89 lb.in (10 Nm)*

3. **NOTE:** *Use new seals.*

*Torque: 22 lb.ft (30 Nm)*

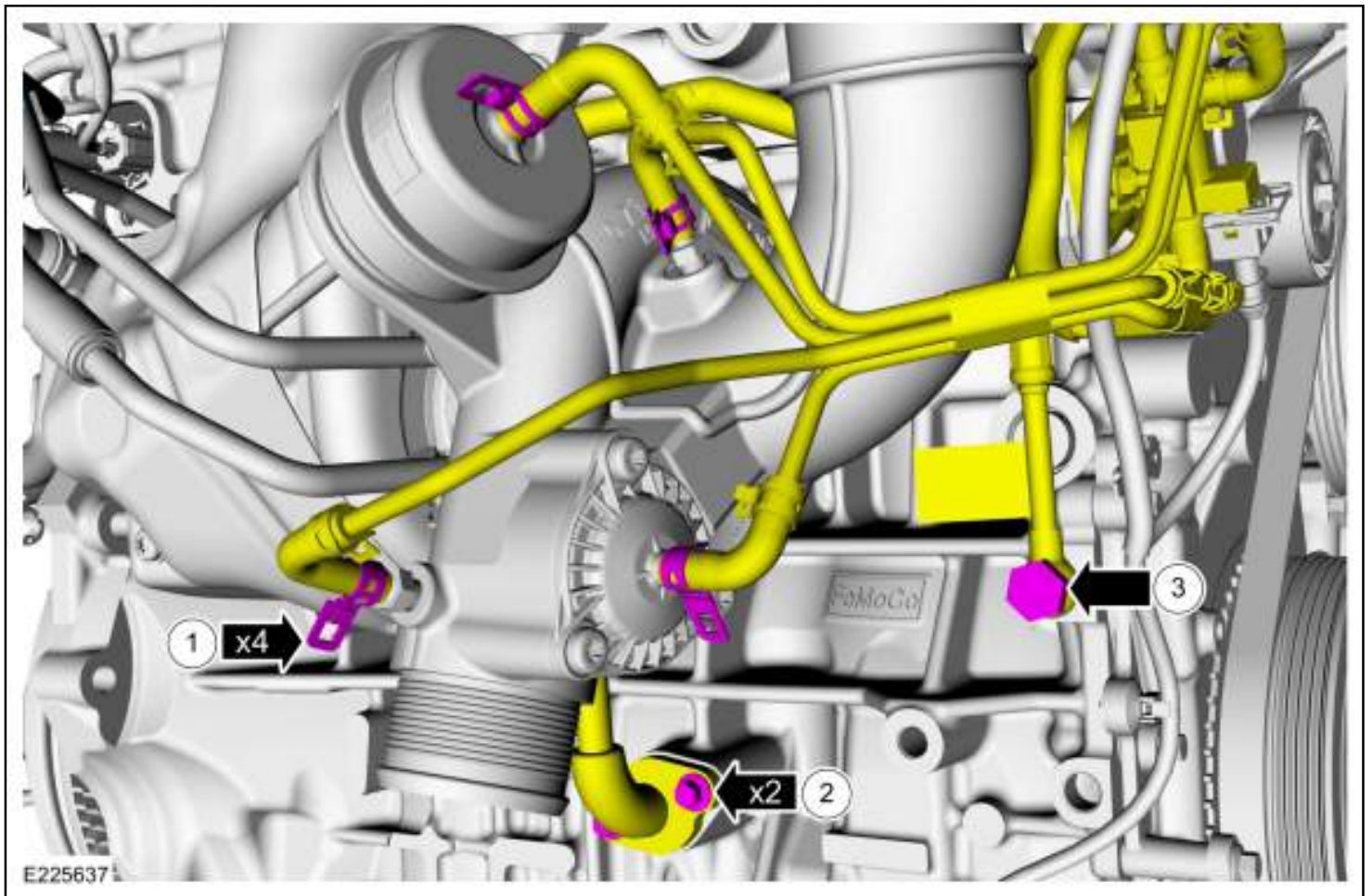

38.

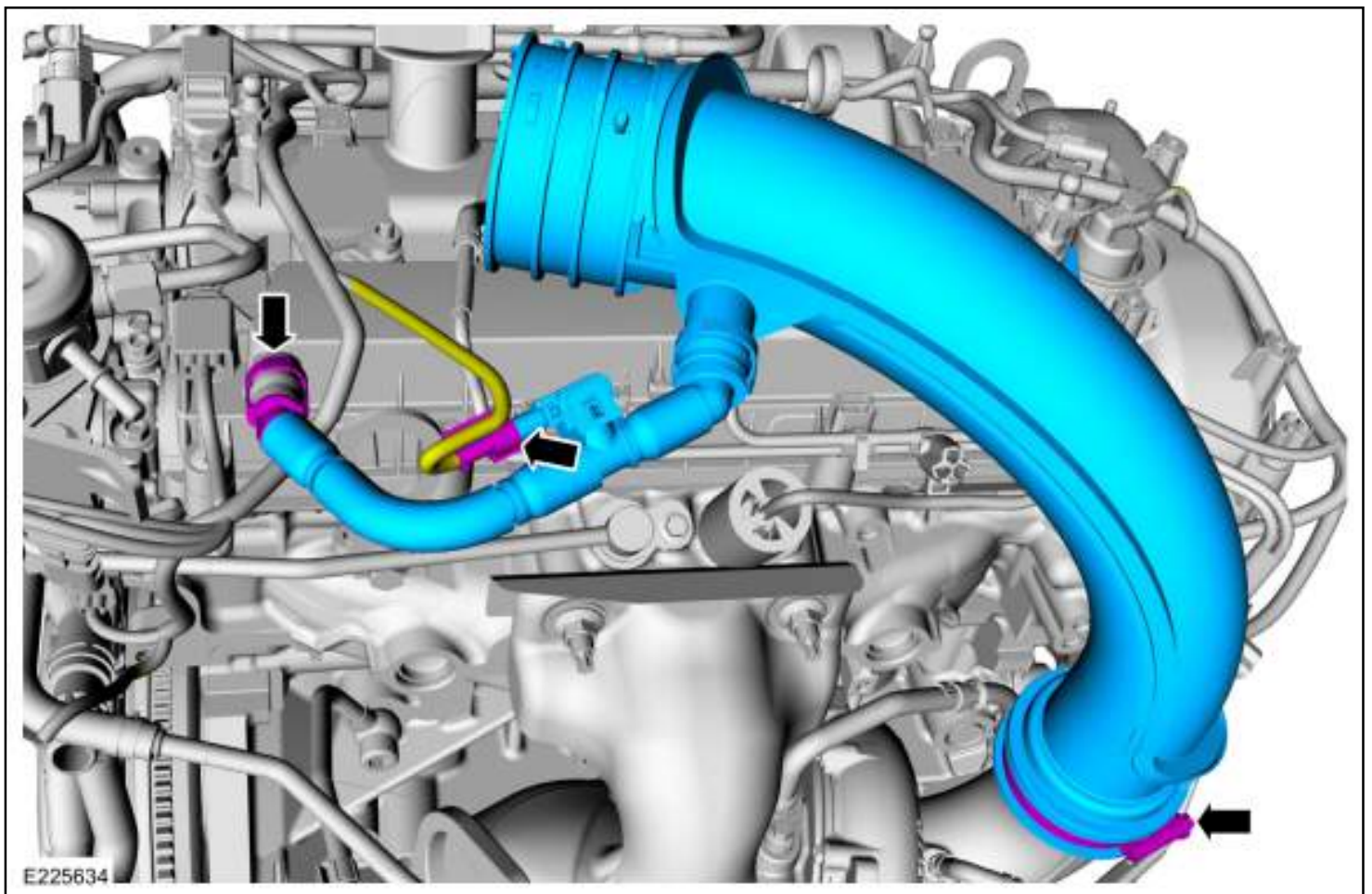



# Engine

Base Part Number: Base Part Number: 6L084

## Special Tool(s) / General Equipment

Lifting Bracket
Floor Crane
Pick Hook
Hose Clamp Remover/Installer
Center Punch
Mounting Table Set
Retaining Strap
Wooden Block
3.5 mm Drill Bit

## Materials

Name	Specification
Grease - High Temperature	ESD-M1C220-A

1. *Material:* Grease - High Temperature (ESD-M1C220-A)

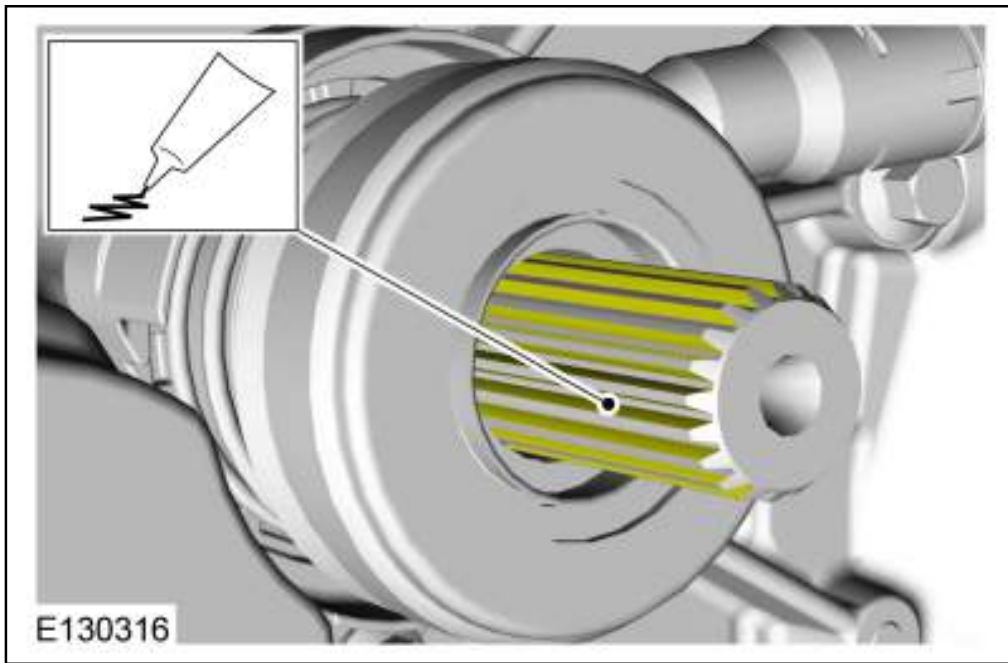

2. **NOTE:** This step requires the aid of another technician.

*Torque: 35 lb.ft (48 Nm)*

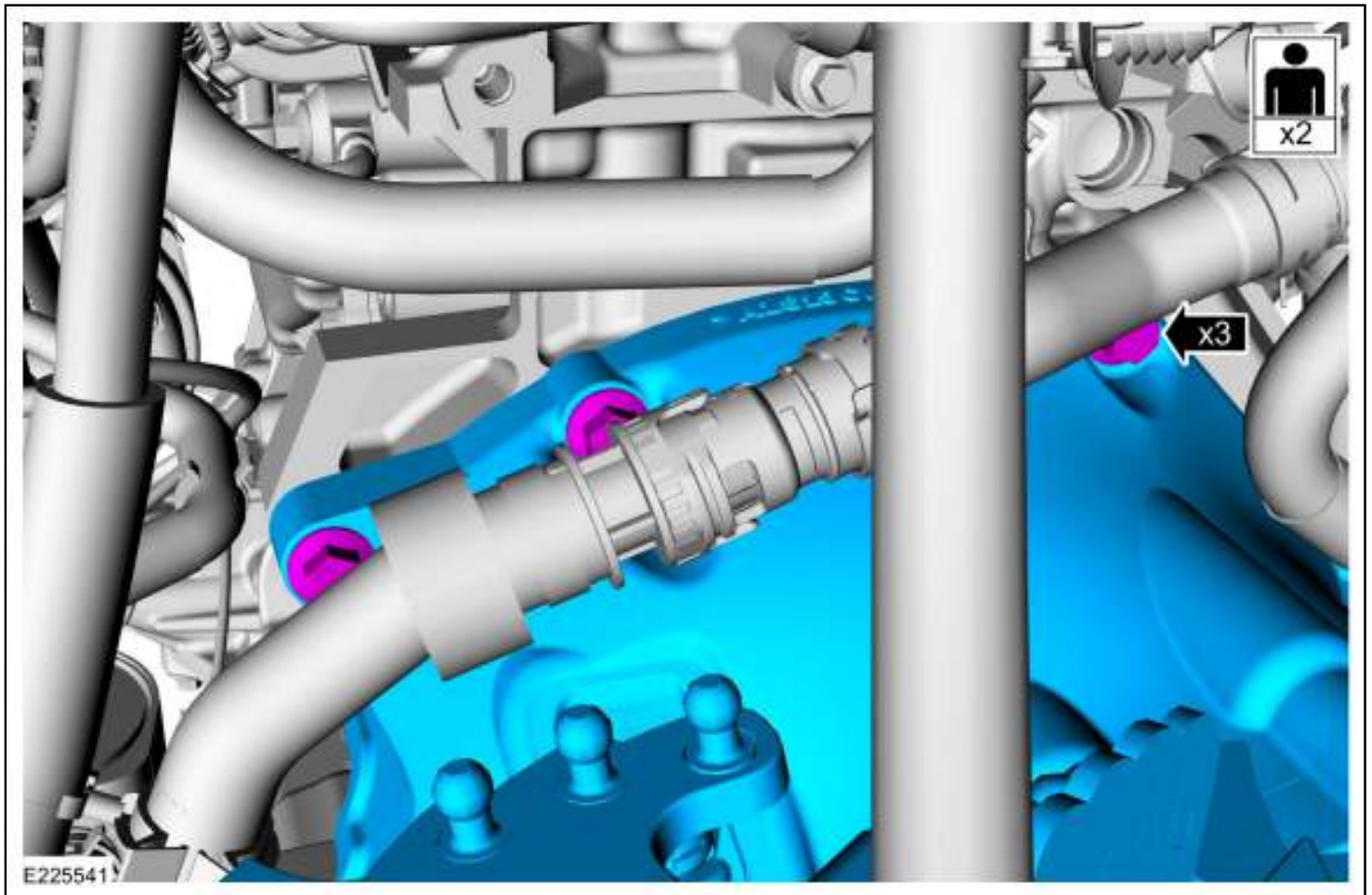

3. *Torque: 35 lb.ft (48 Nm)*

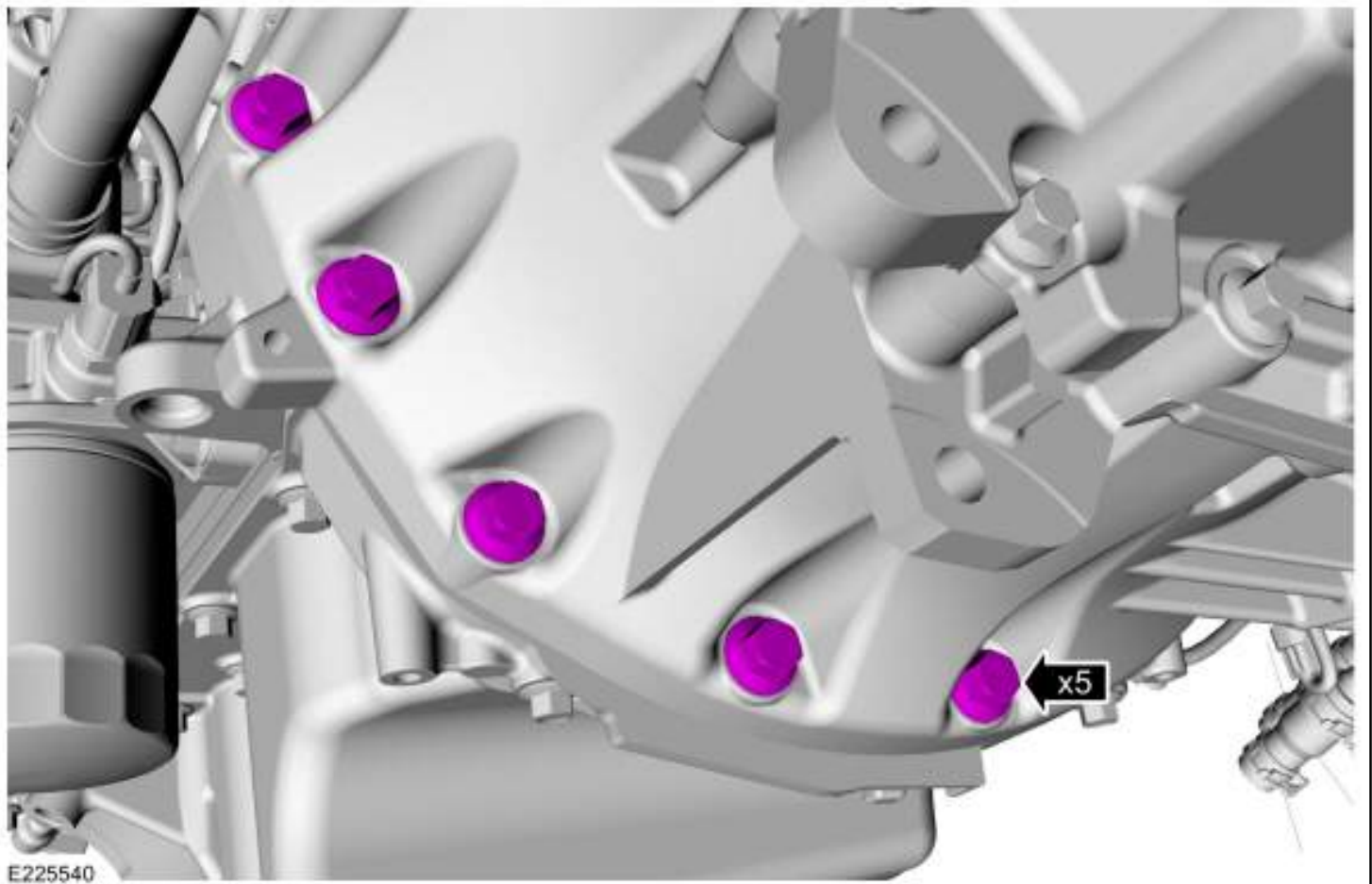

4. Torque: 35 lb.ft (48 Nm)

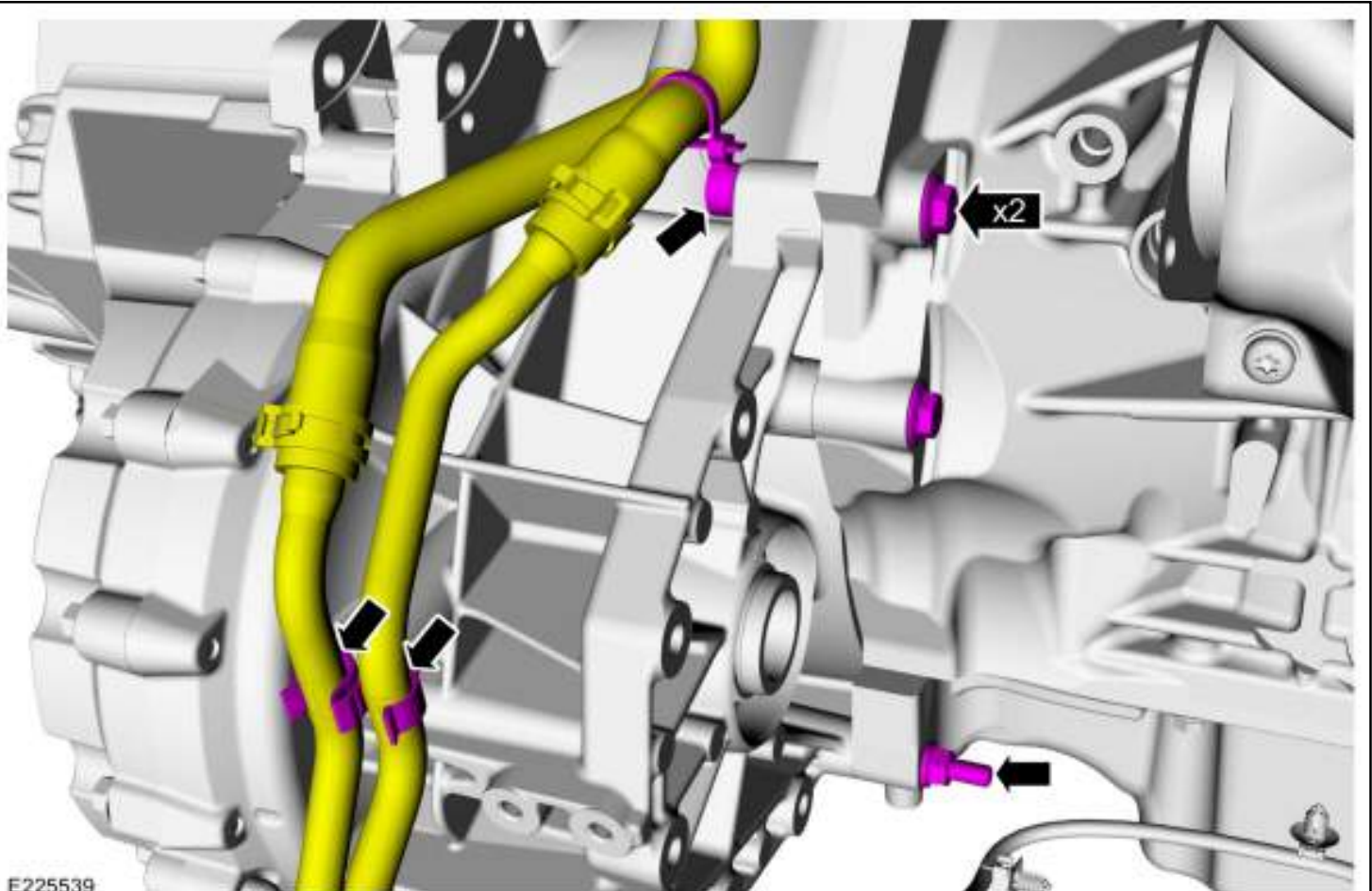

5.

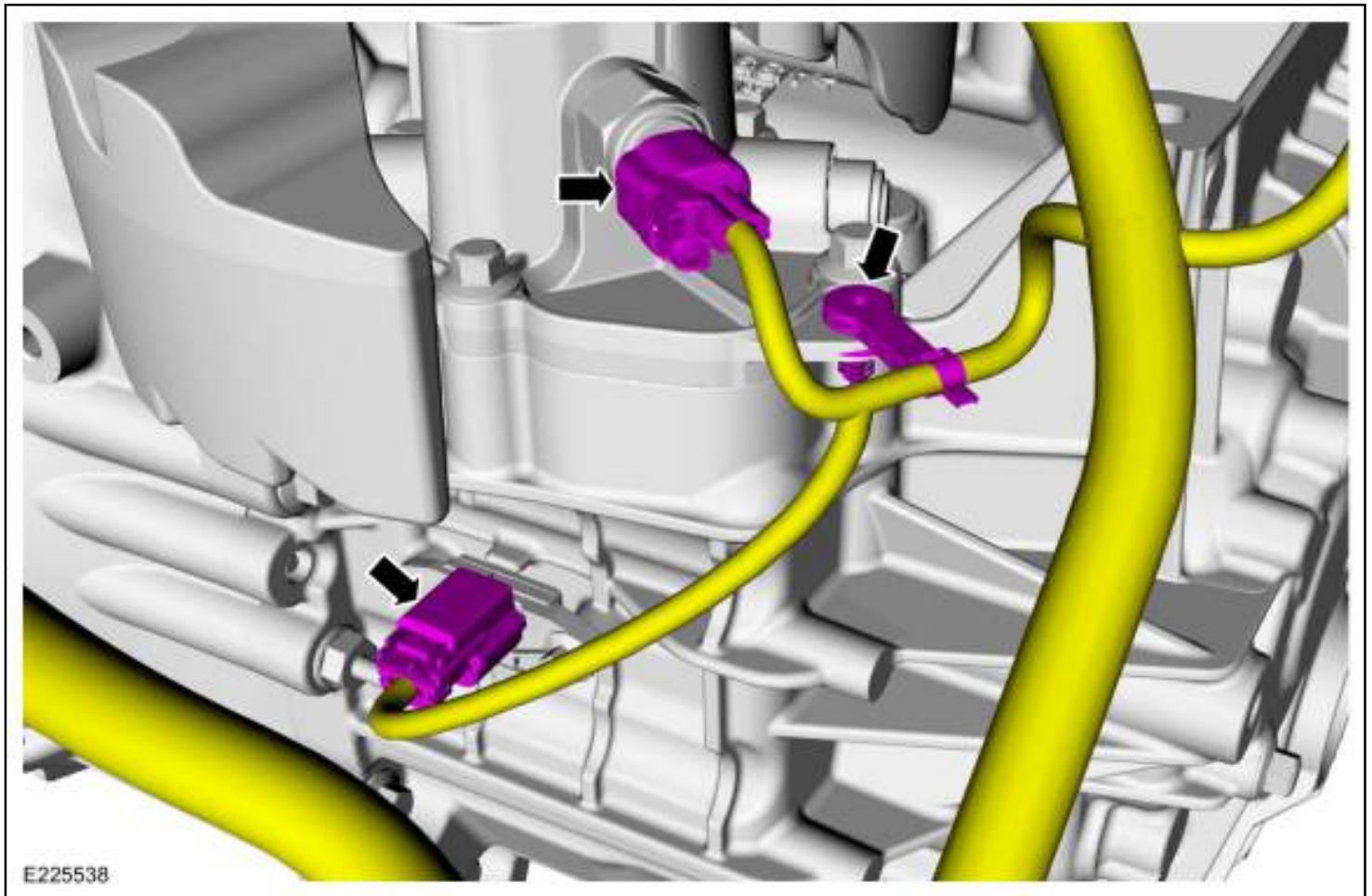

6.  **WARNING:** Always secure engines, transmissions, or other heavy components to the support fixture with straps and wooden support blocks. Improperly secured assemblies could fall off the fixture, resulting in serious personal injury.

Install the following items:

- Use the General Equipment: Mounting Table Set
- Use the General Equipment: Wooden Block
- Use the General Equipment: Retaining Strap

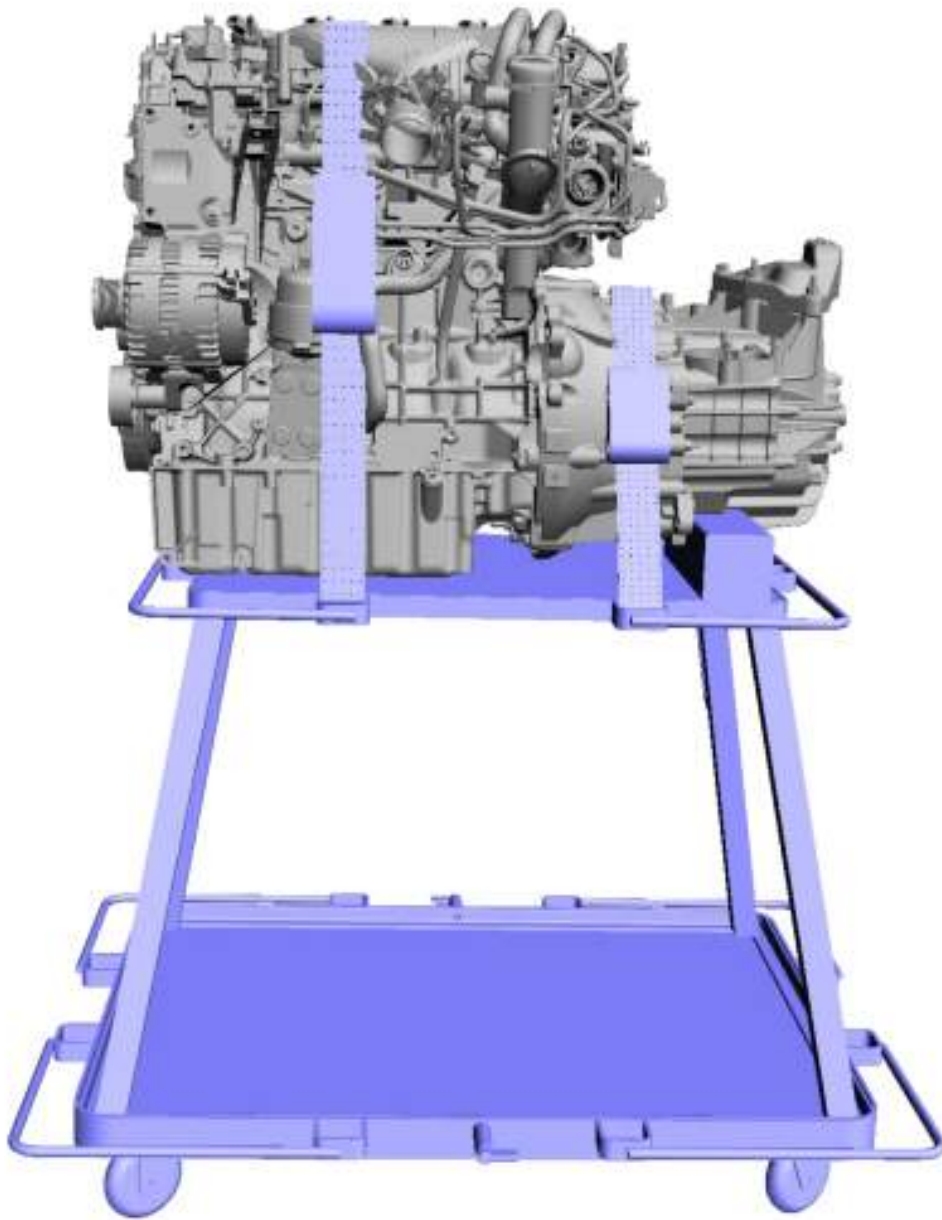

E89490



7. Remove the following items:

1. Use the General Equipment: Lifting Bracket  
Use the General Equipment: Floor Crane

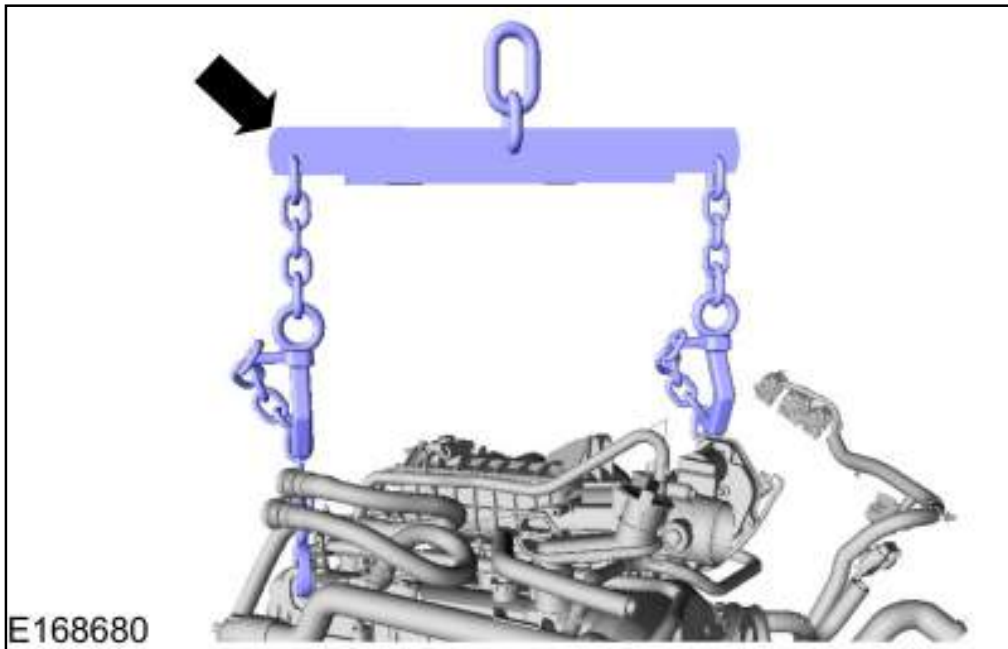

8.



9. *Torque:* 133 lb.in (15 Nm)

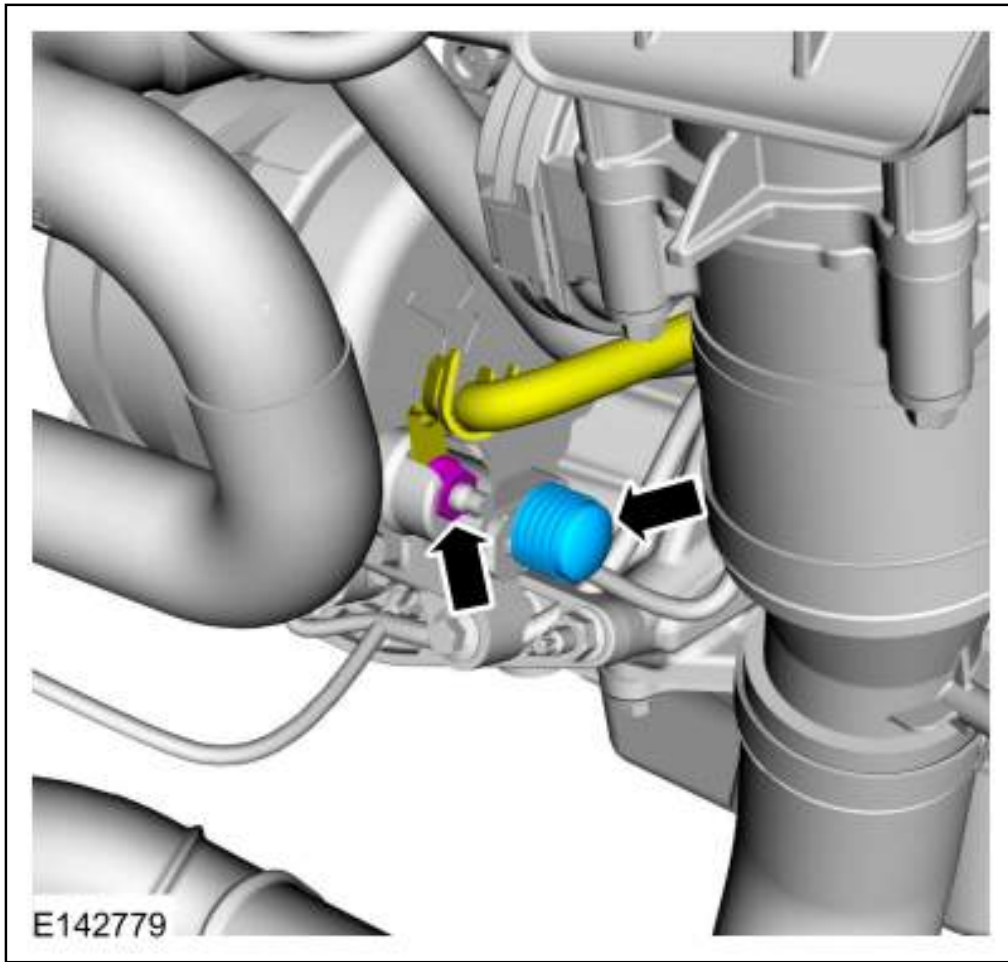

1. *Torque:* 26 lb.ft (35 Nm)
2. *Torque:* 106 lb.in (12 Nm)
3. *Torque:* 159 lb.in (18 Nm)

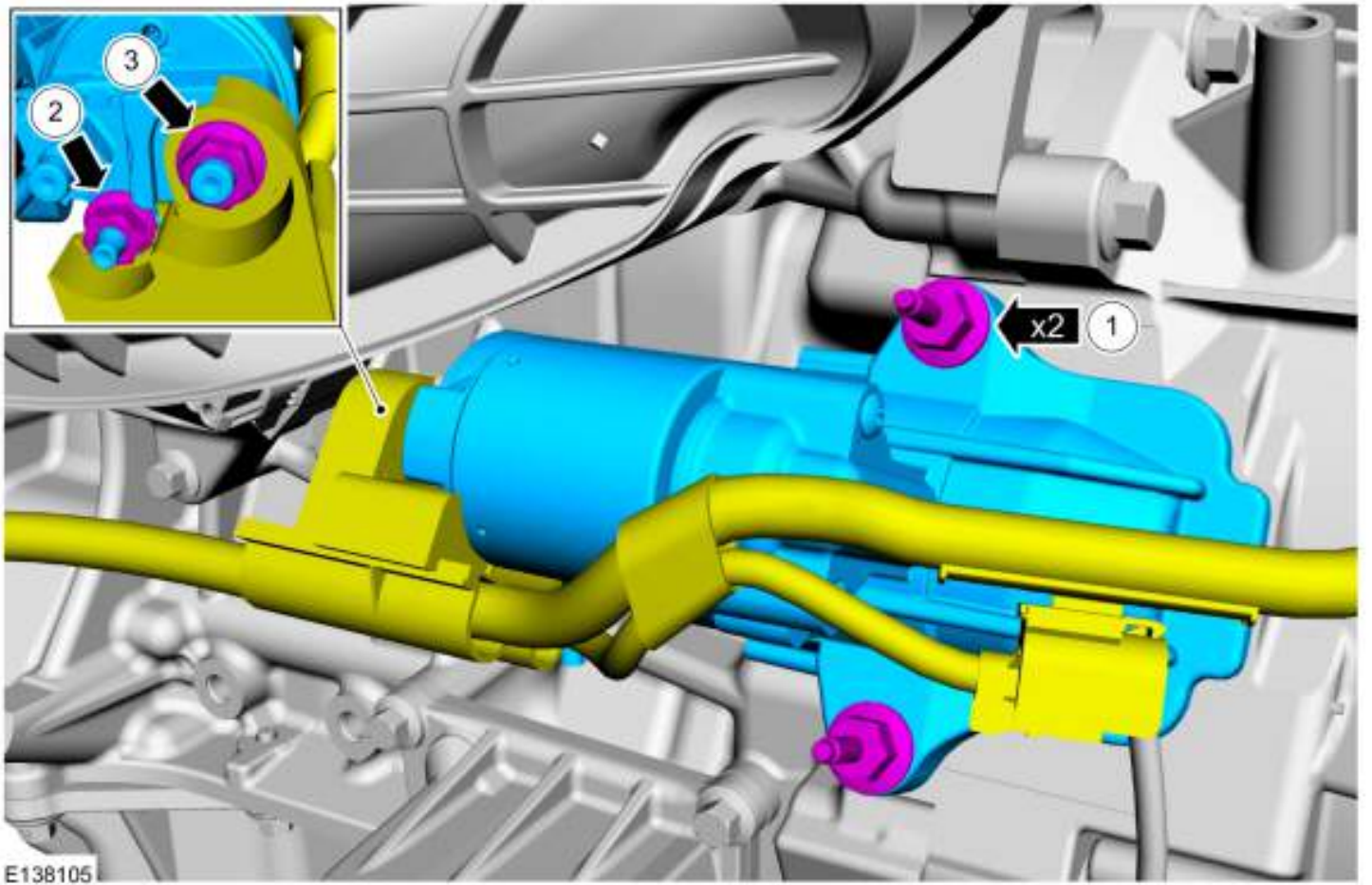

E138105

11. *Torque:* 89 lb.in (10 Nm)

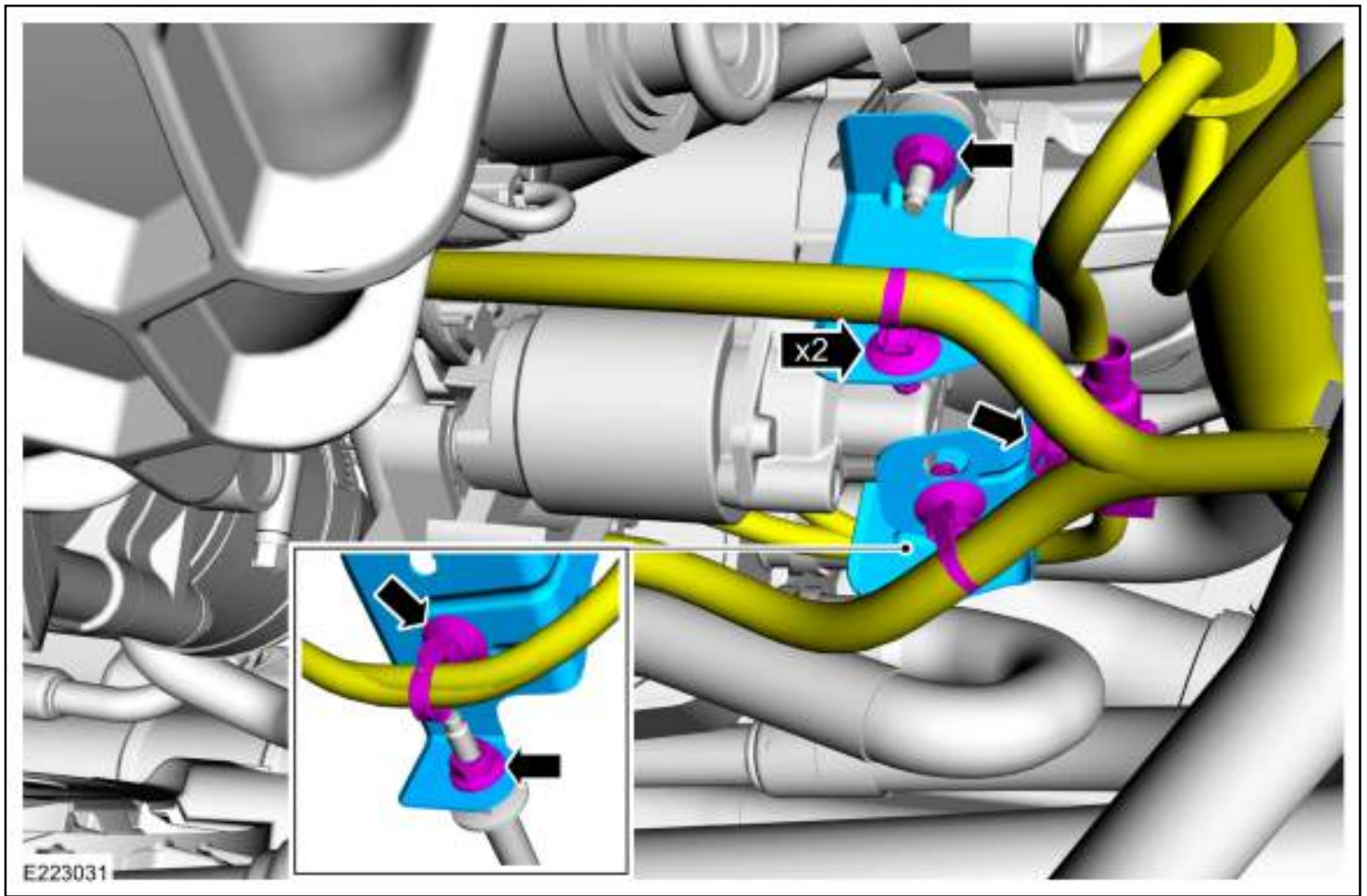

12. **NOTICE:** Make sure that no components catch.

Lower the vehicle.



13.

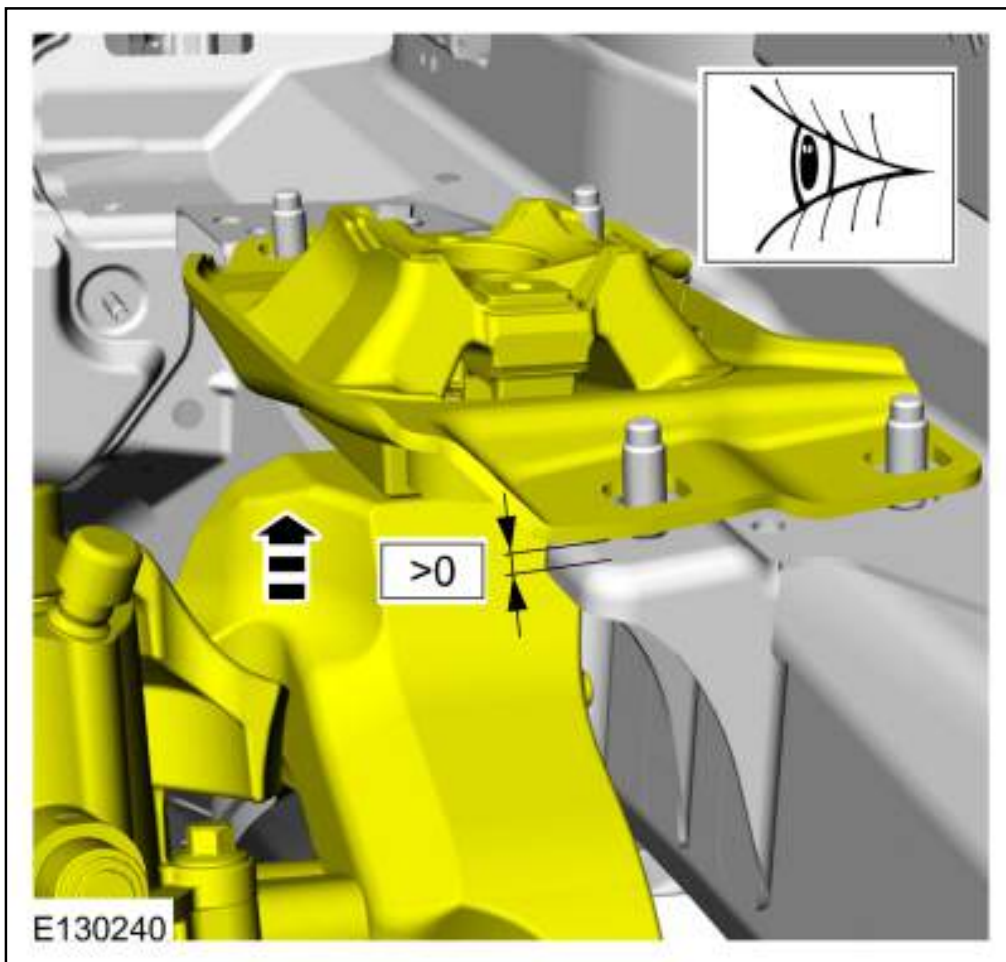

14. **NOTICE: Make sure that a new bolt is installed.**

*Torque: 109 lb.ft (148 Nm)*

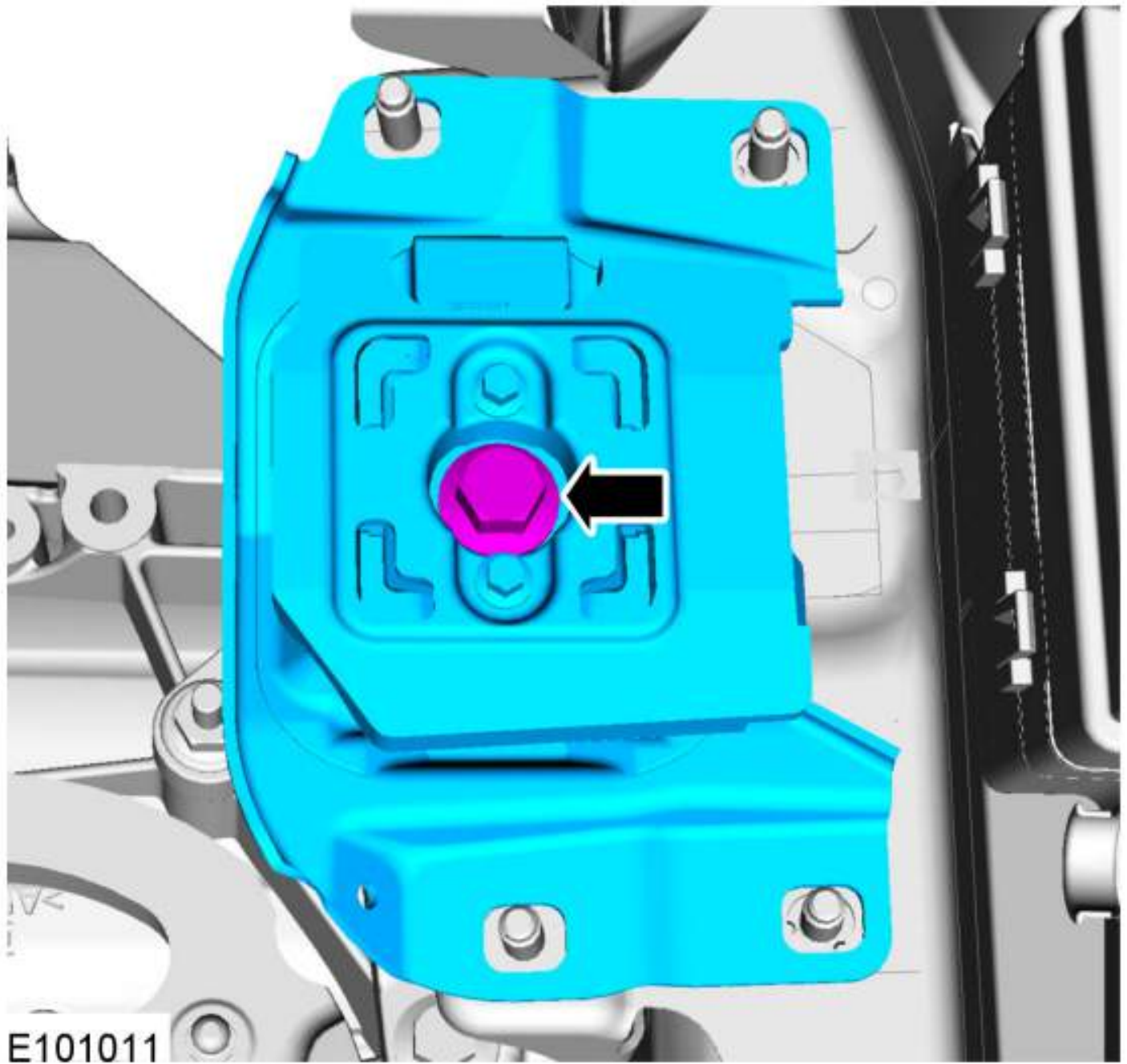

15. *Torque:* 106 lb.in (12 Nm)

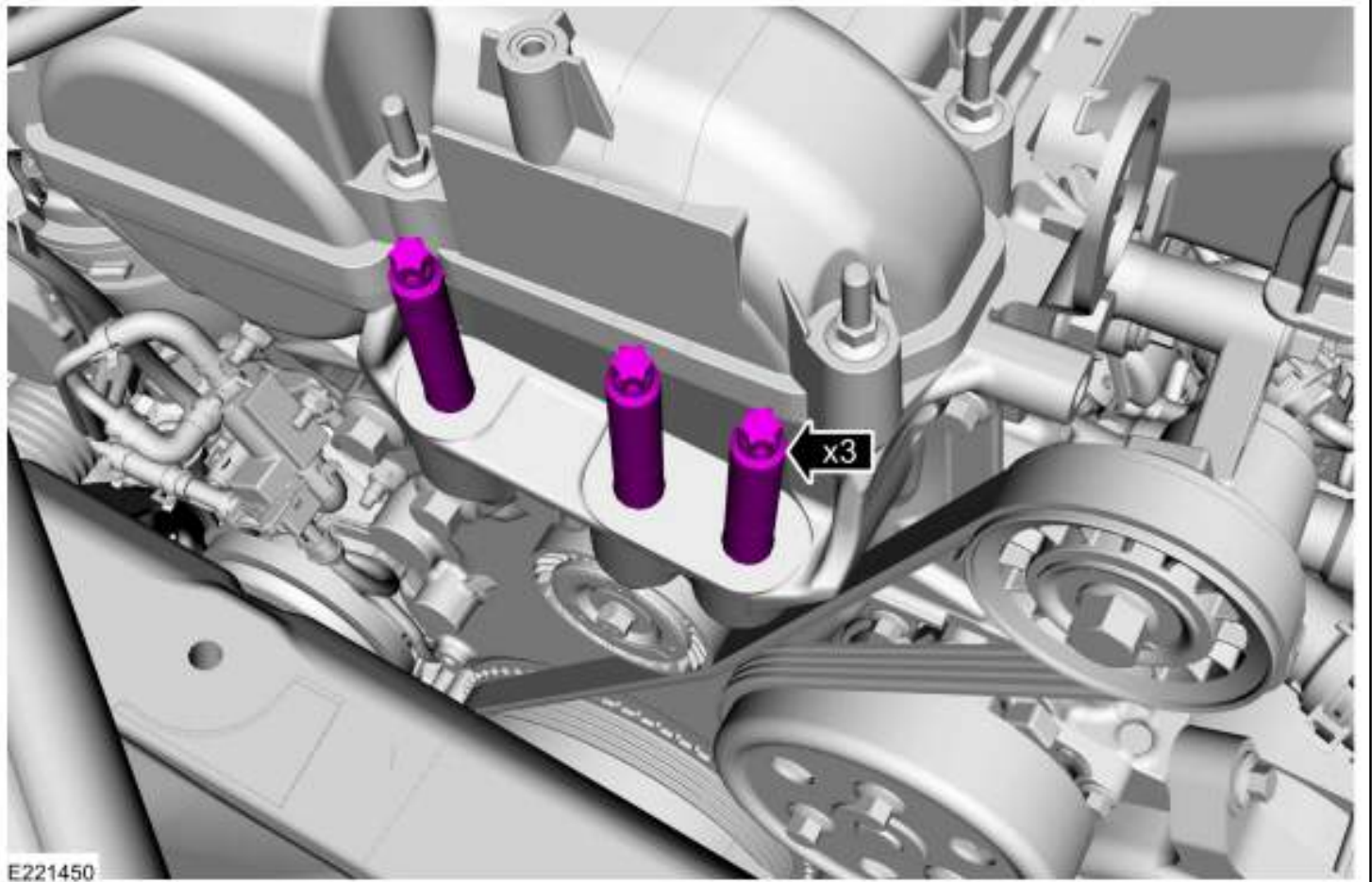

1. *Torque: 59 lb.ft (80 Nm)*
2. **NOTE:** *Only tighten the bolts finger tight at this stage.*



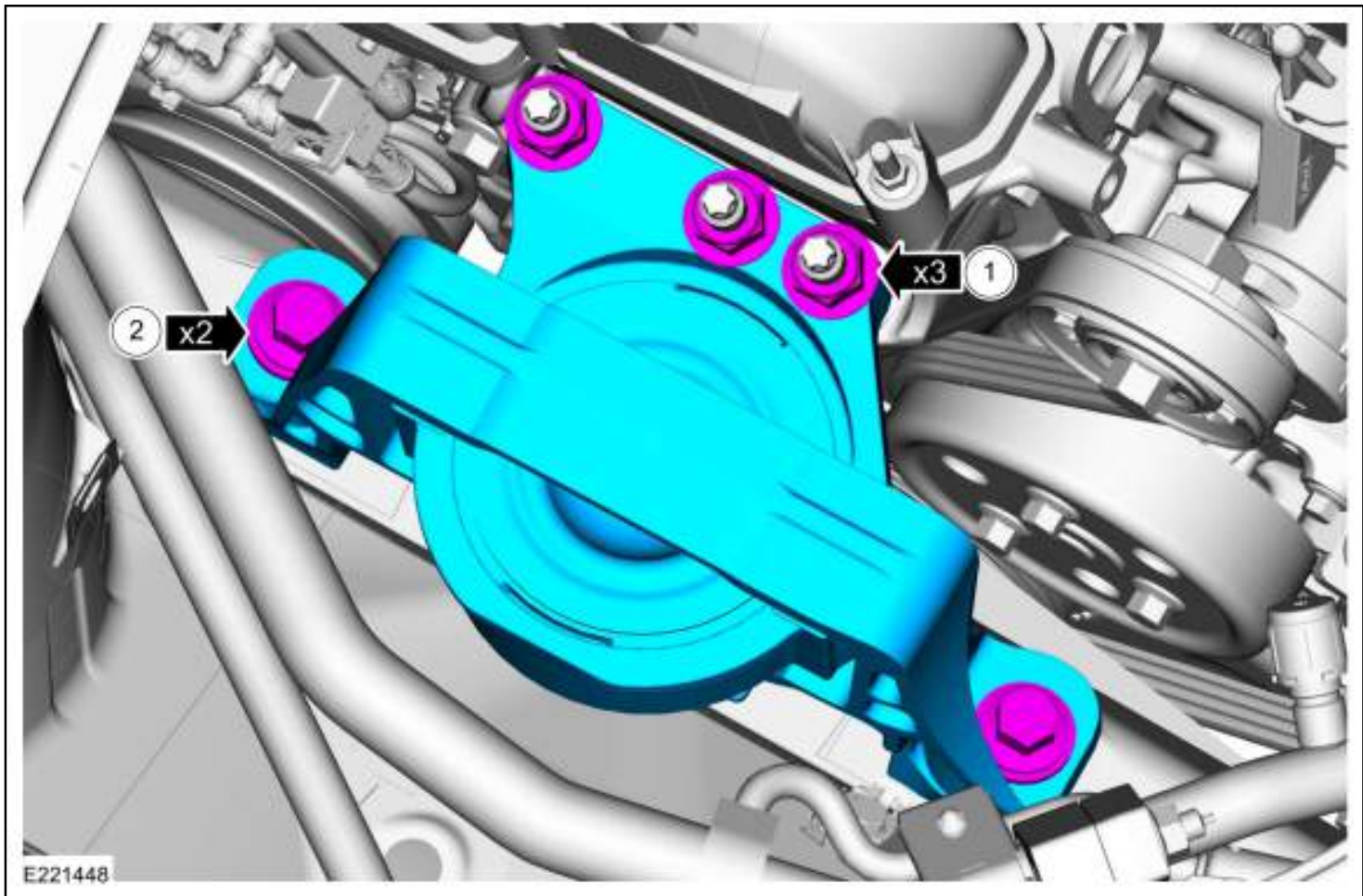

17. Remove the following items:

- Use the General Equipment: Mounting Table Set
- Use the General Equipment: Wooden Block
- Use the General Equipment: Retaining Strap



18. *Torque:* 35 lb.ft (48 Nm)

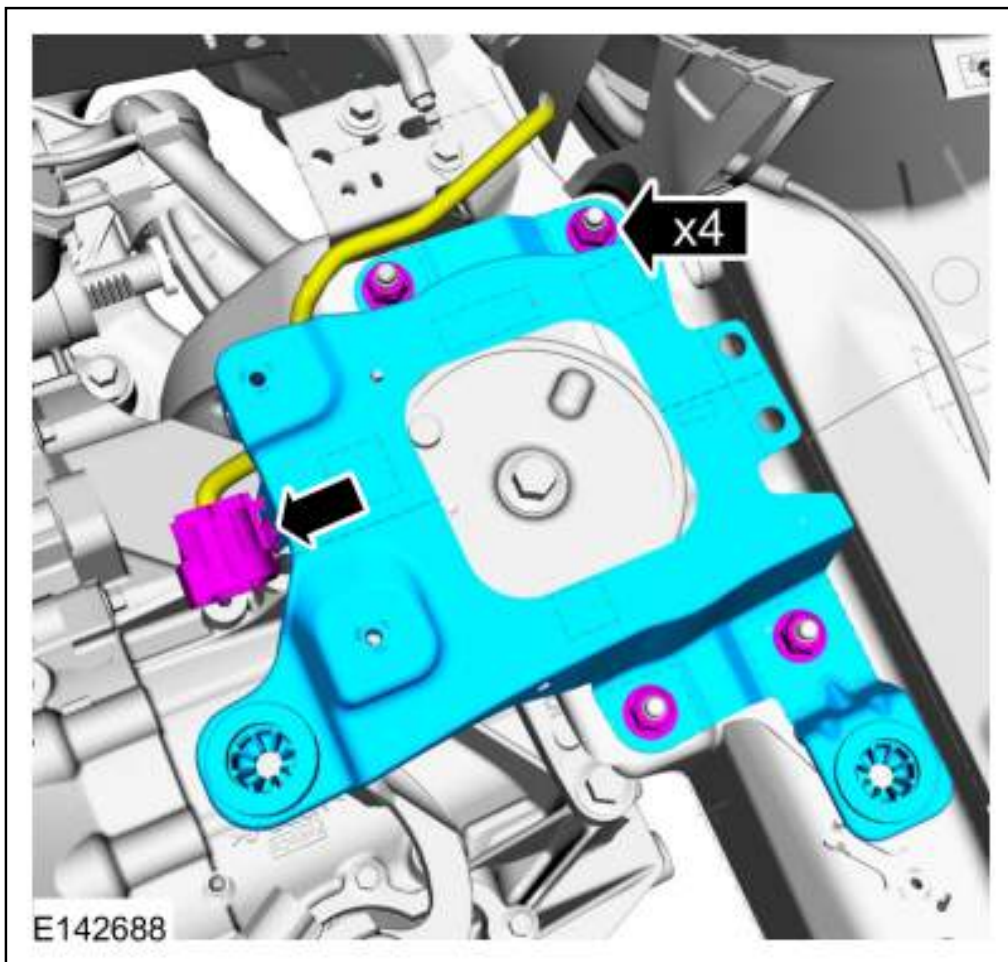

19. *Torque:* 66 lb.ft (90 Nm)

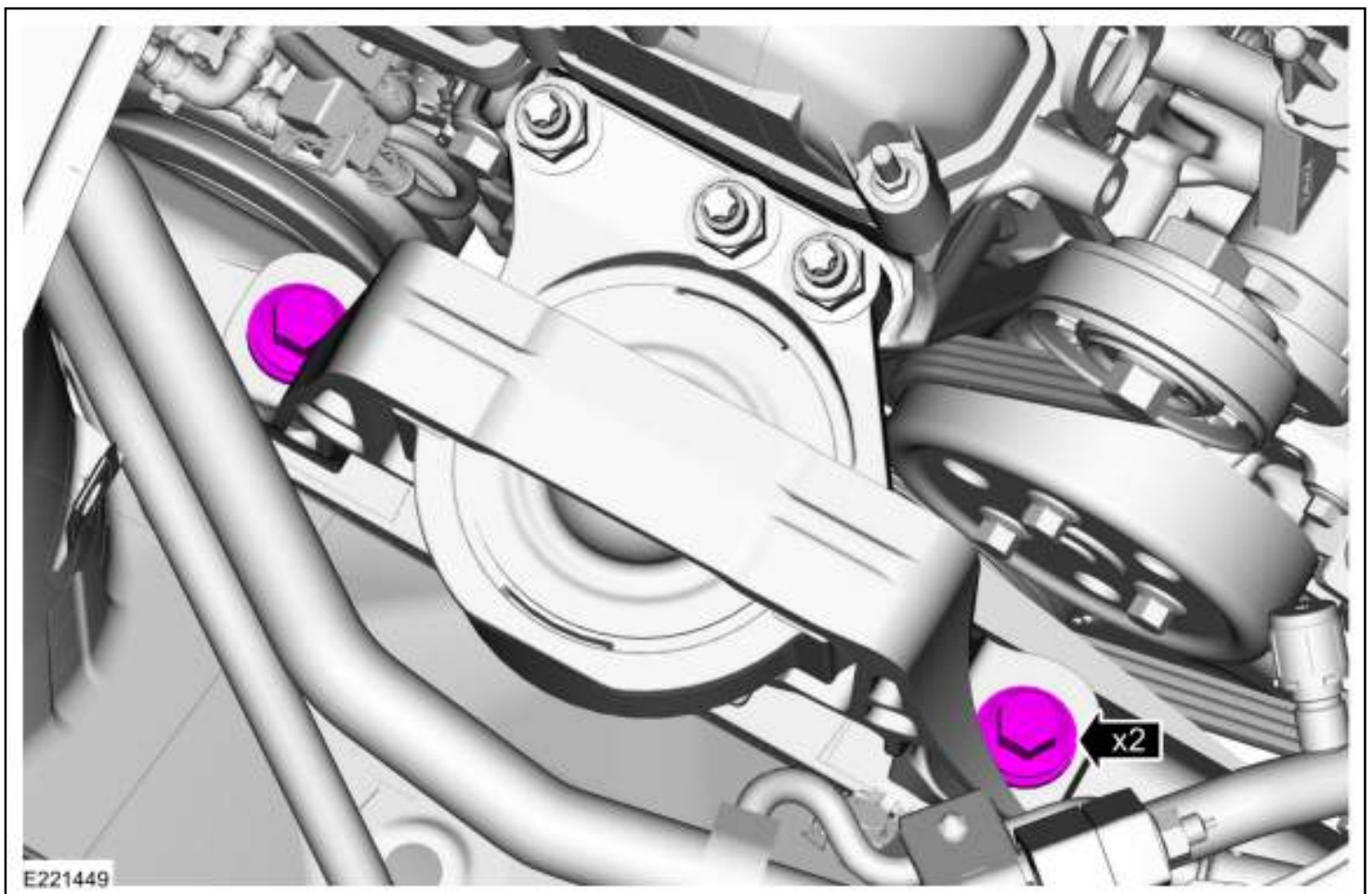

20.

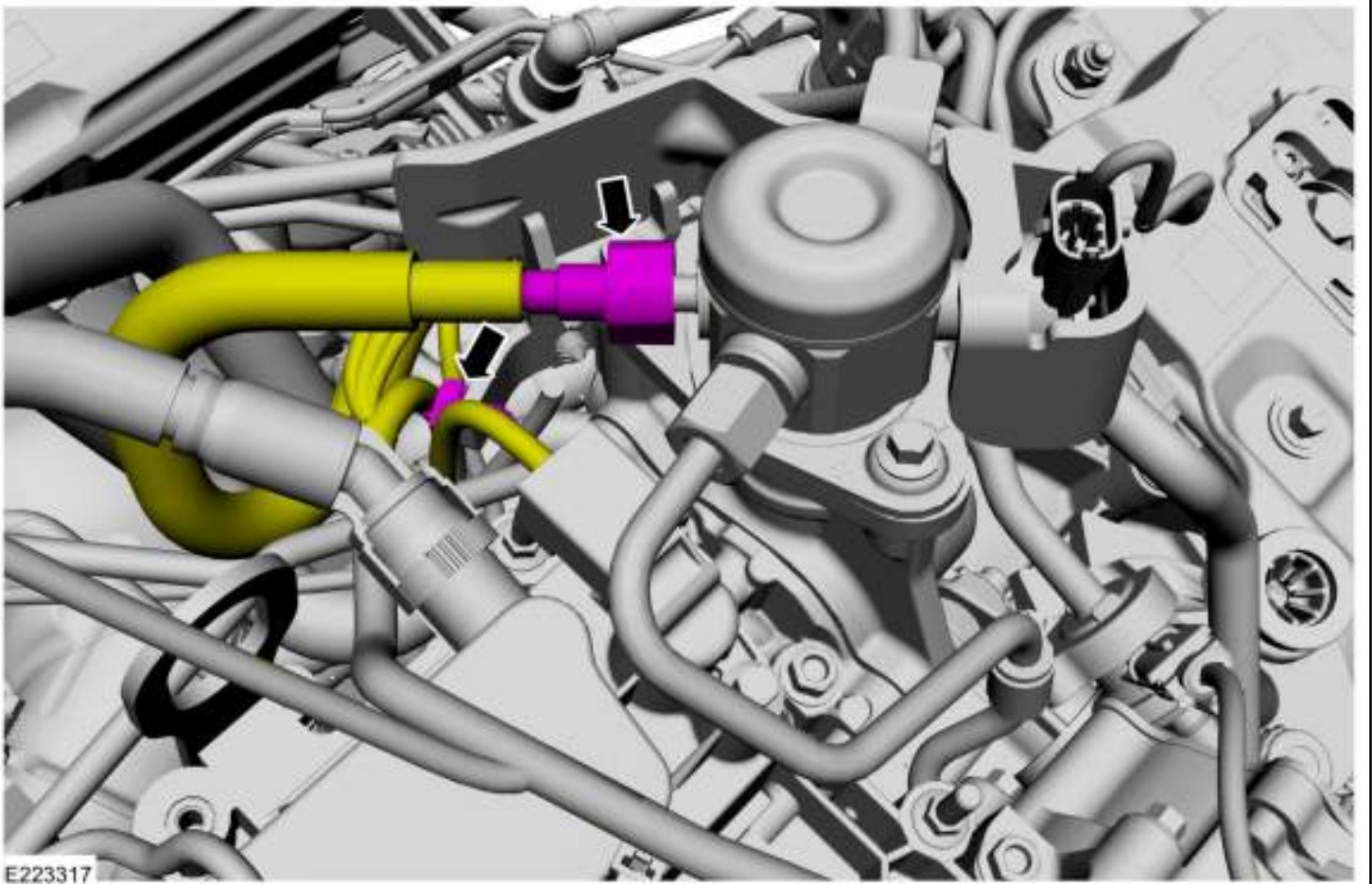

21. **NOTICE:** Make sure that all openings are sealed.

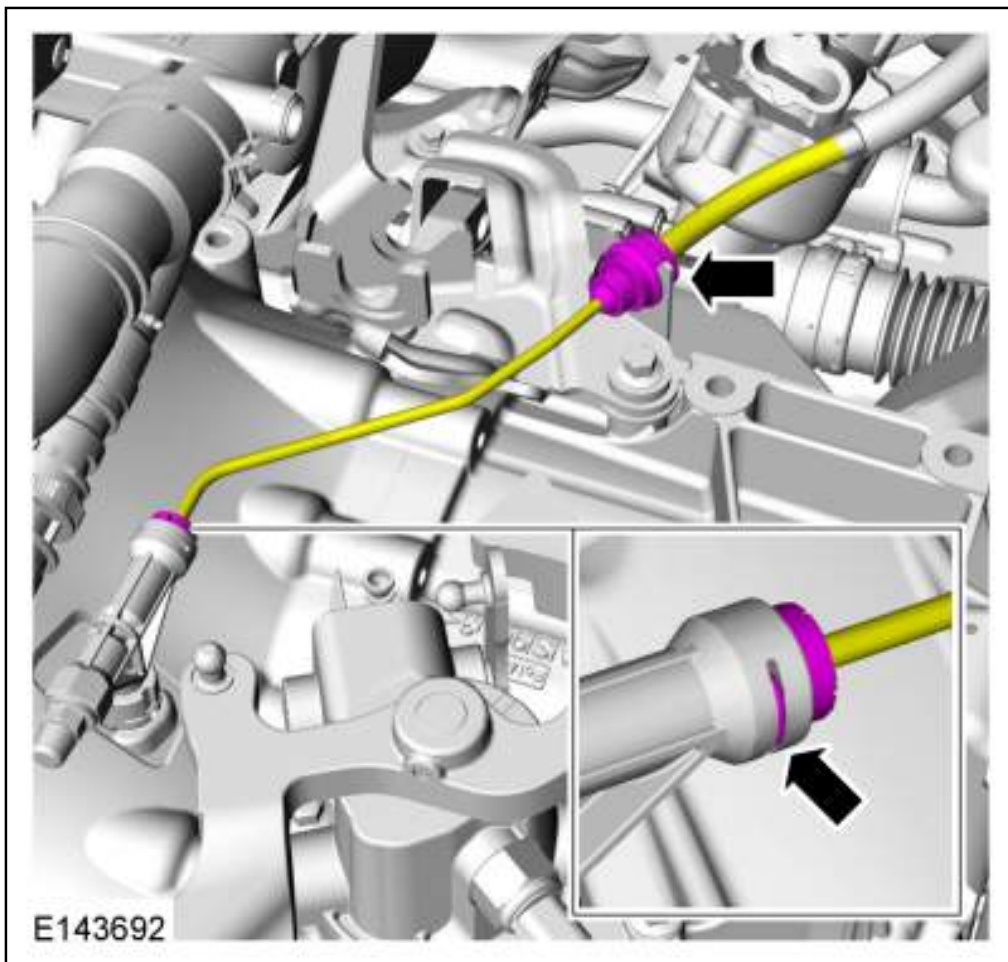

22. Refer to: Clutch System Bleeding (308-02D) .

23. **NOTICE:** Gearshift cables must not be kinked or bent.

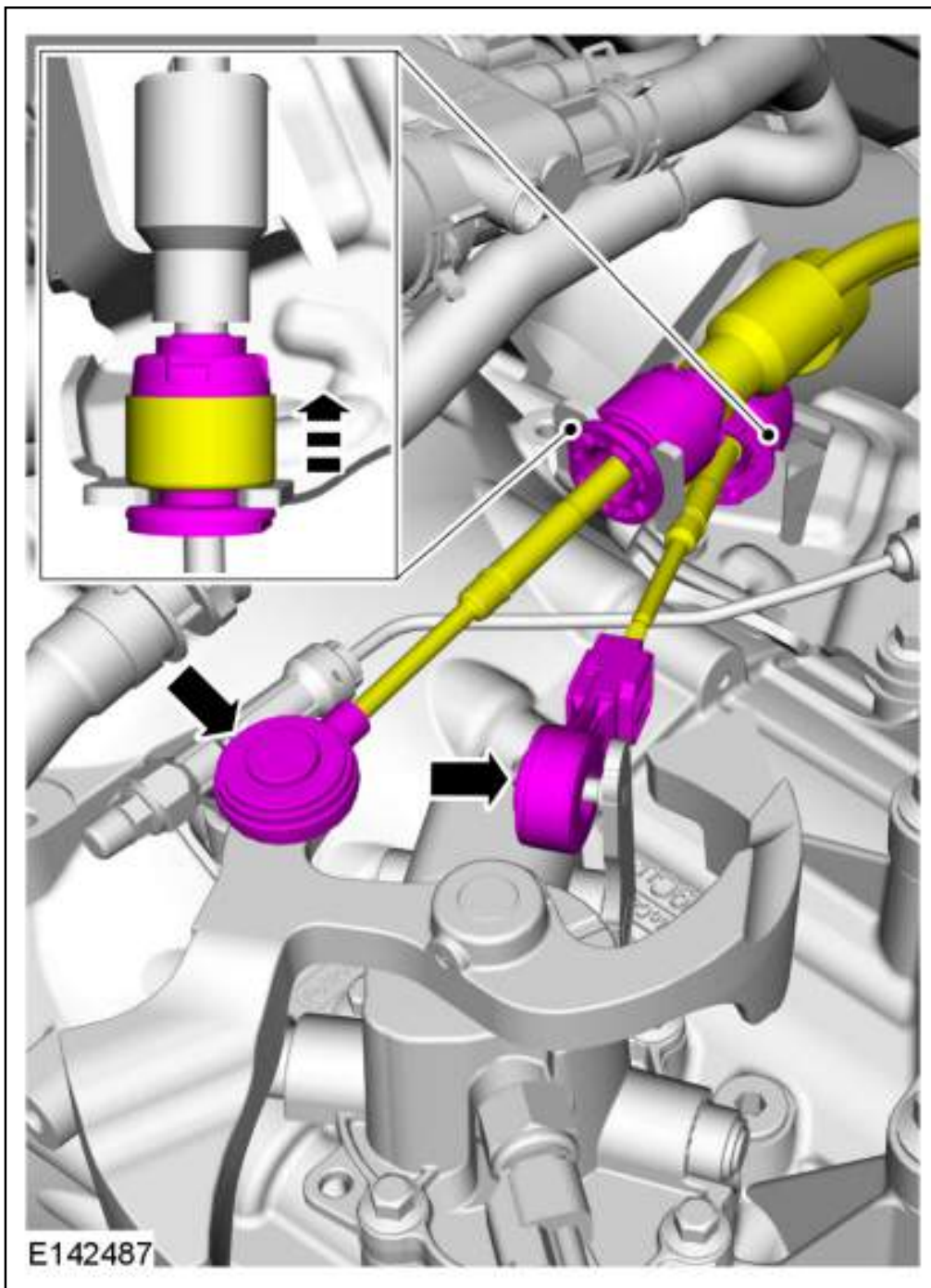

cardiagn.com

Refer to: Front Halfshaft LH - Attach to the transmission - 5-Speed Manual Transmission - B5/IB5/5-Speed Manual Transmission - MTX75/6-Speed Manual Transmission - B6/6-Speed Manual Transmission - MMT6/6-Speed PowerShift Transmission - DPS6/6DCT250 ( ) .

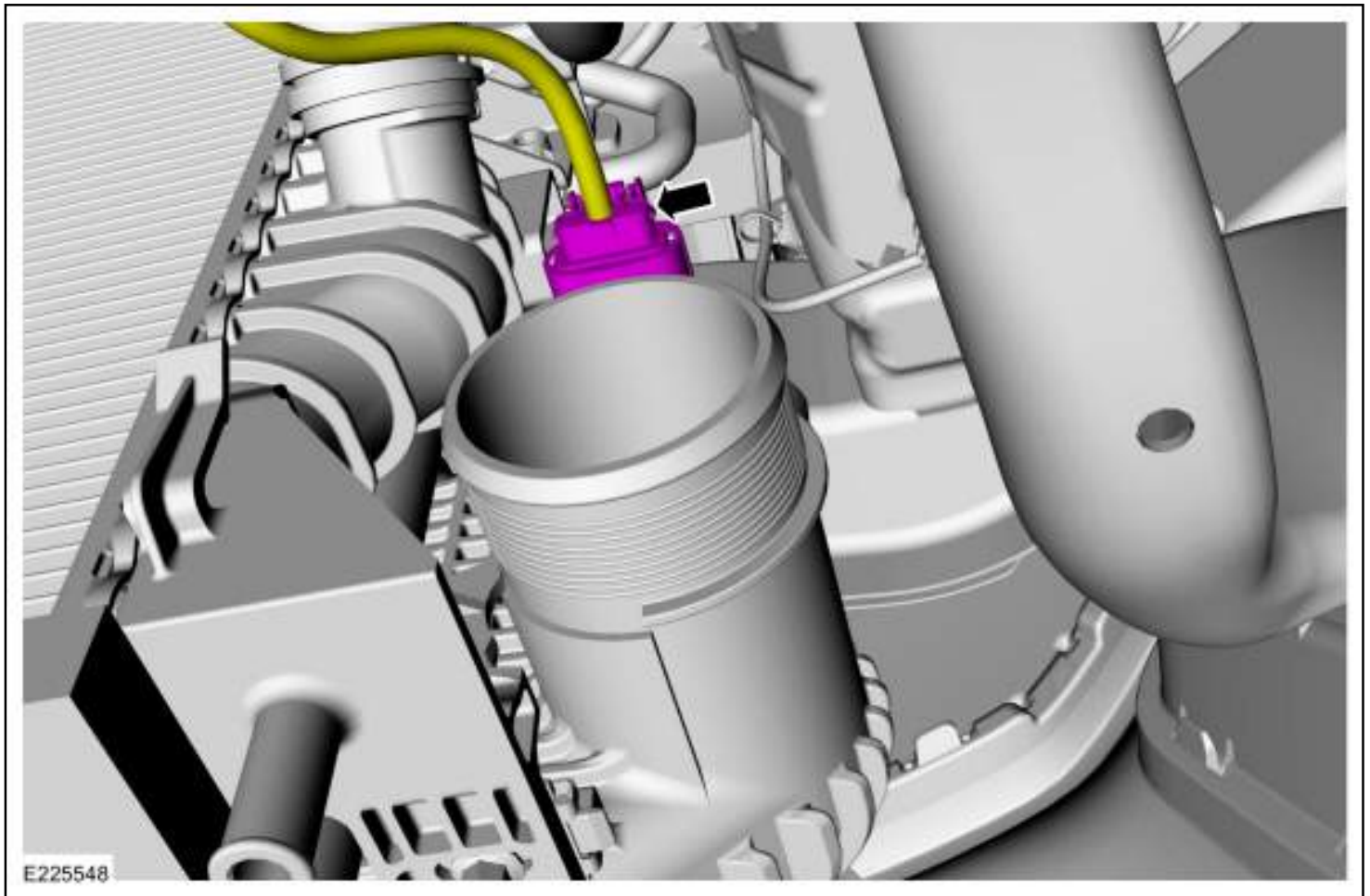

25. **NOTICE:** Make sure that no strain is placed on the fuel lines and wiring harnesses.

Remove the following items:

- Use the General Equipment: Pick Hook

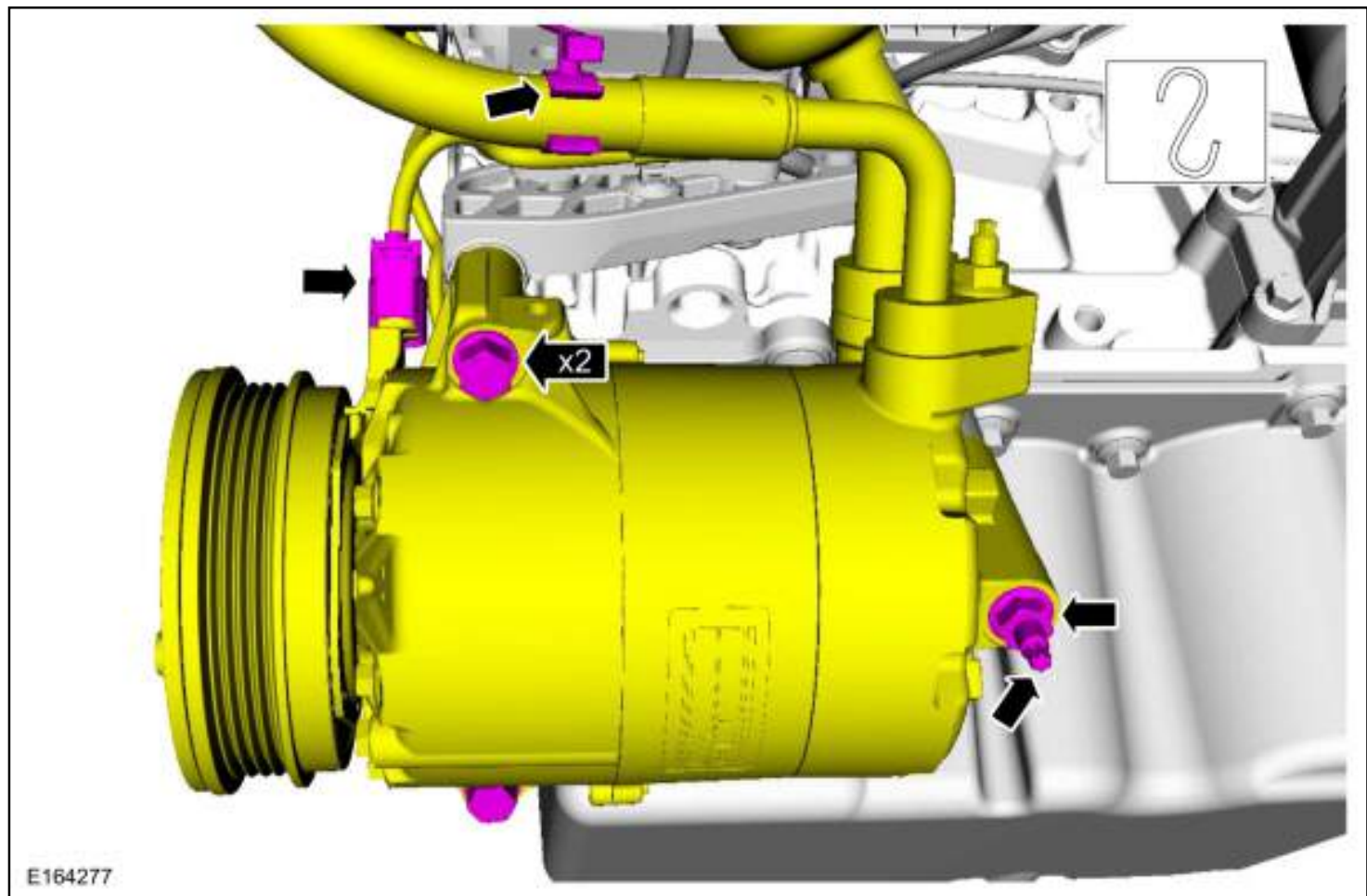

26.

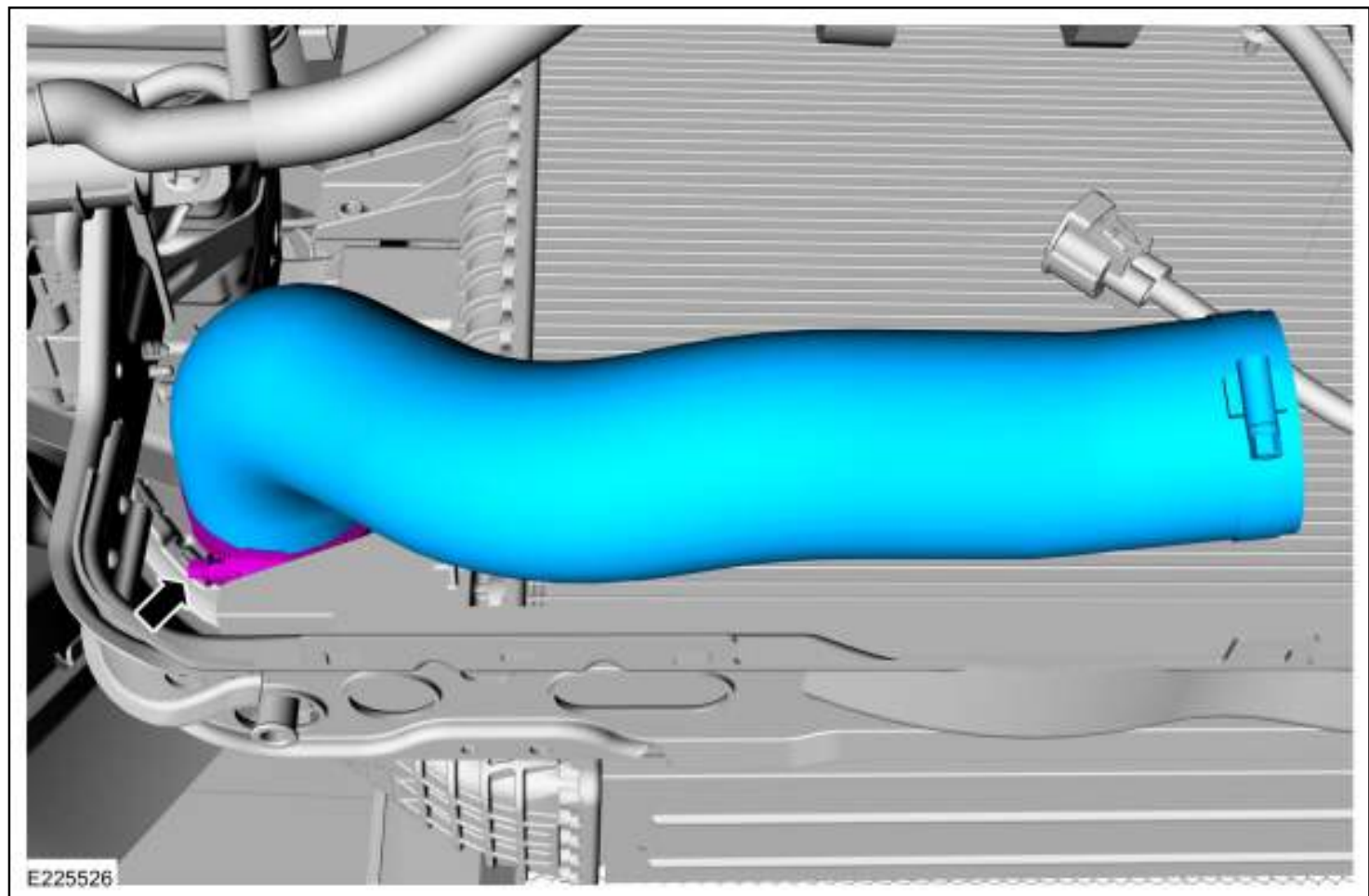

27.

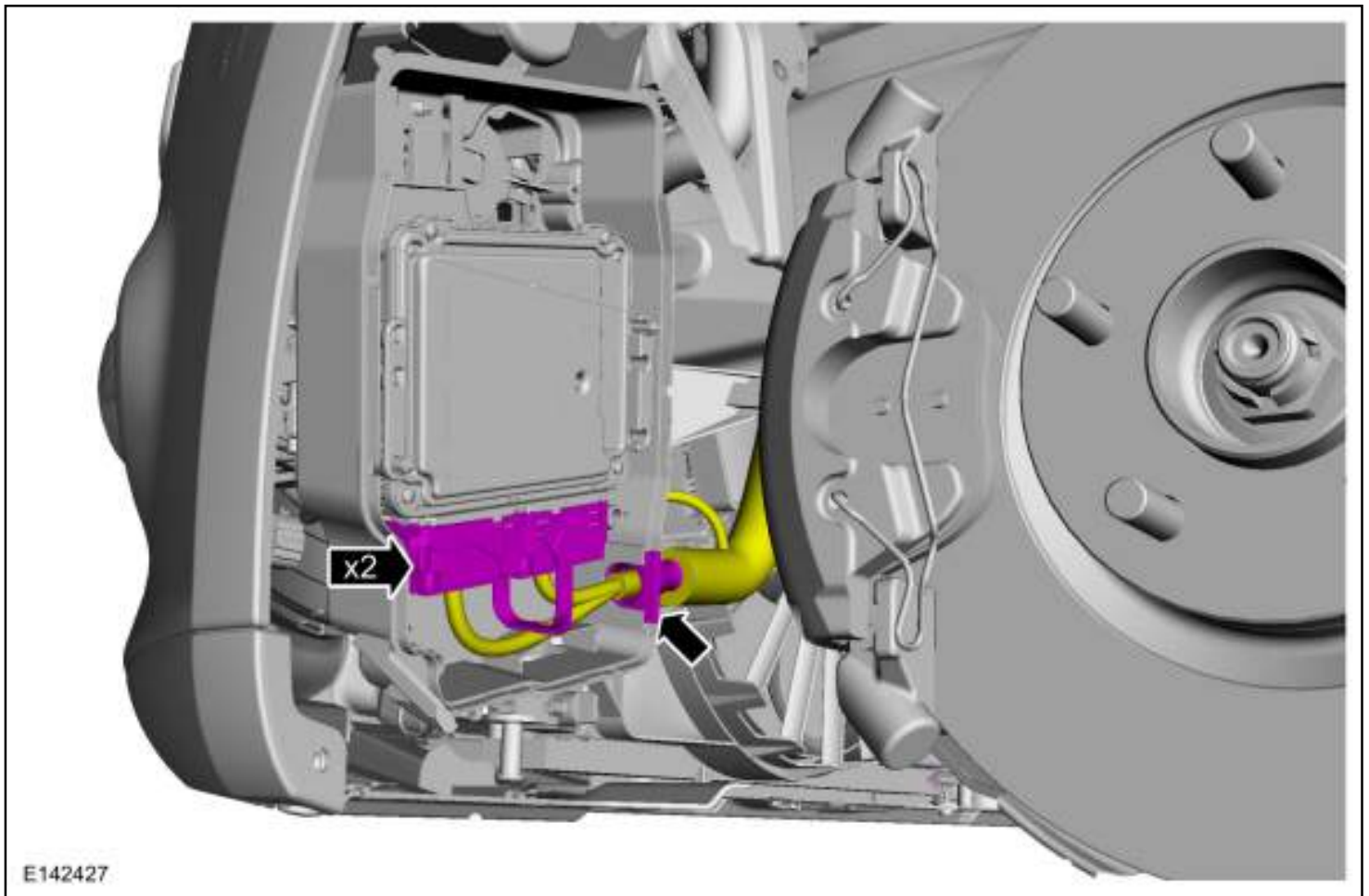

cardiag

**Vehicles with PCM security shield**

- 28. Use the General Equipment: Center Punch
- Use the General Equipment: 3.5 mm Drill Bit

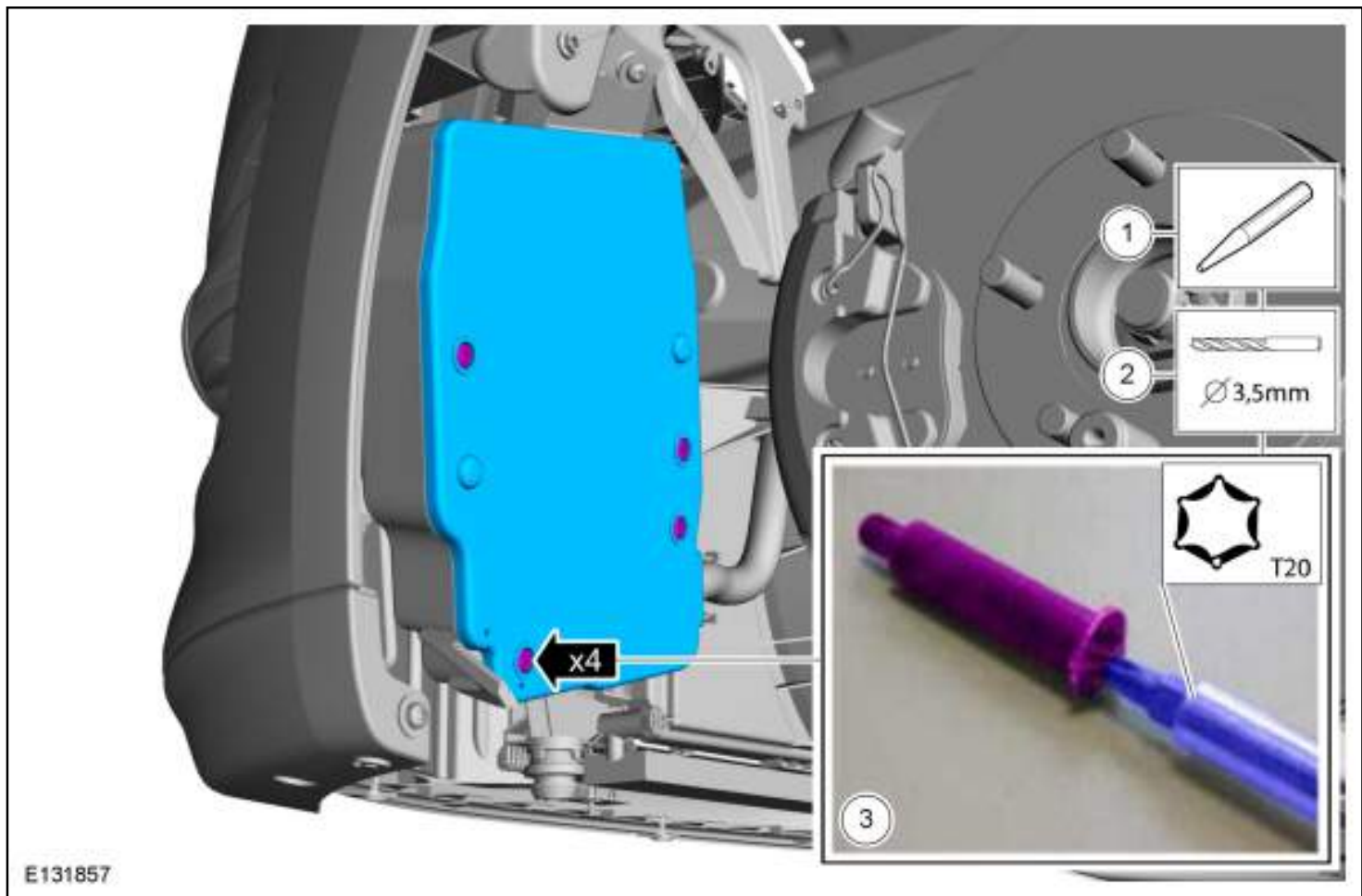

**Vehicles without PCM security shield**

29.

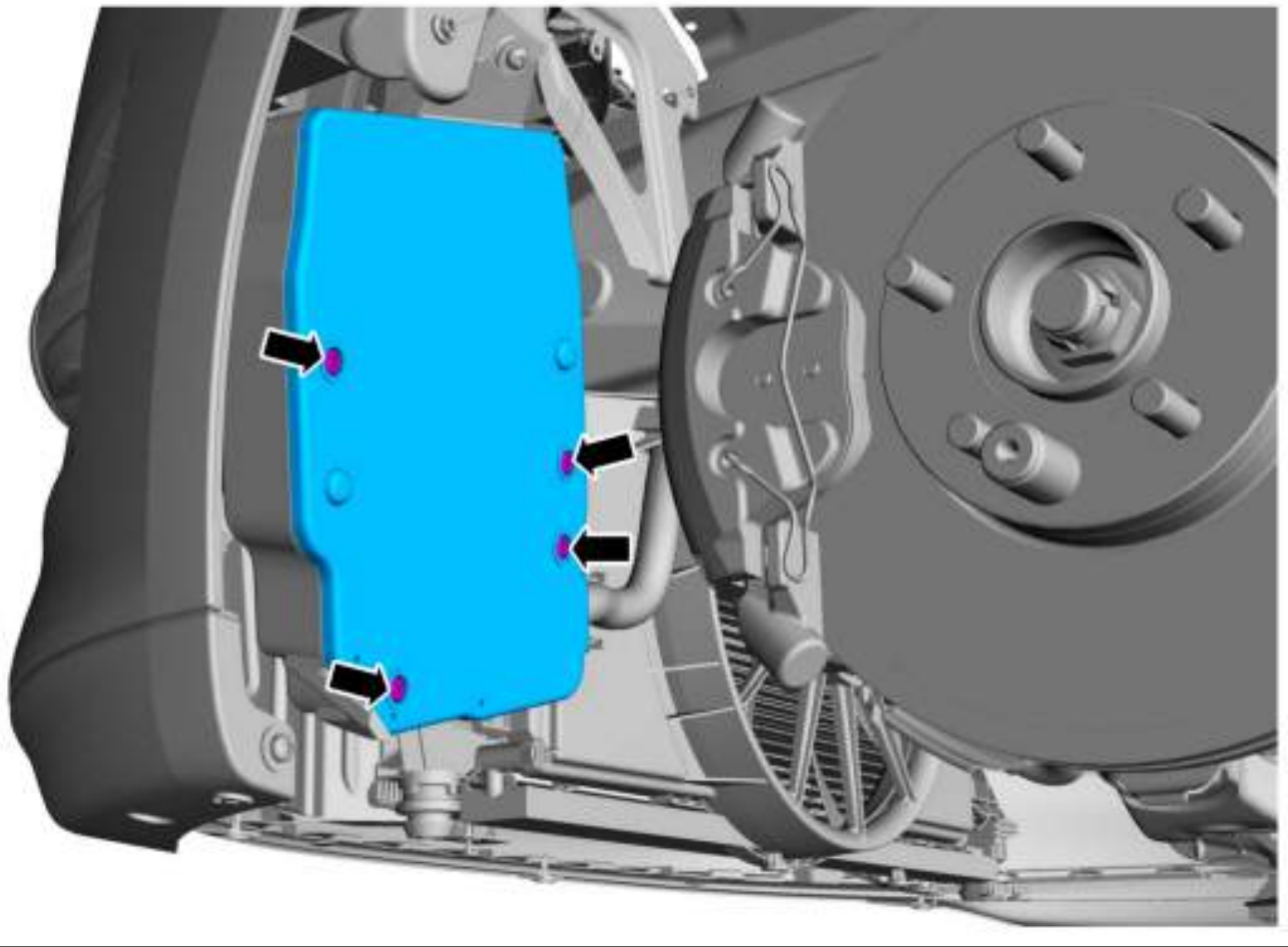

E131654



cardiagn.com

## All vehicles

30. Refer to: Fender Splash Shield (501-02 Front End Body Panels) .
31. Use the General Equipment: Hose Clamp Remover/Installer

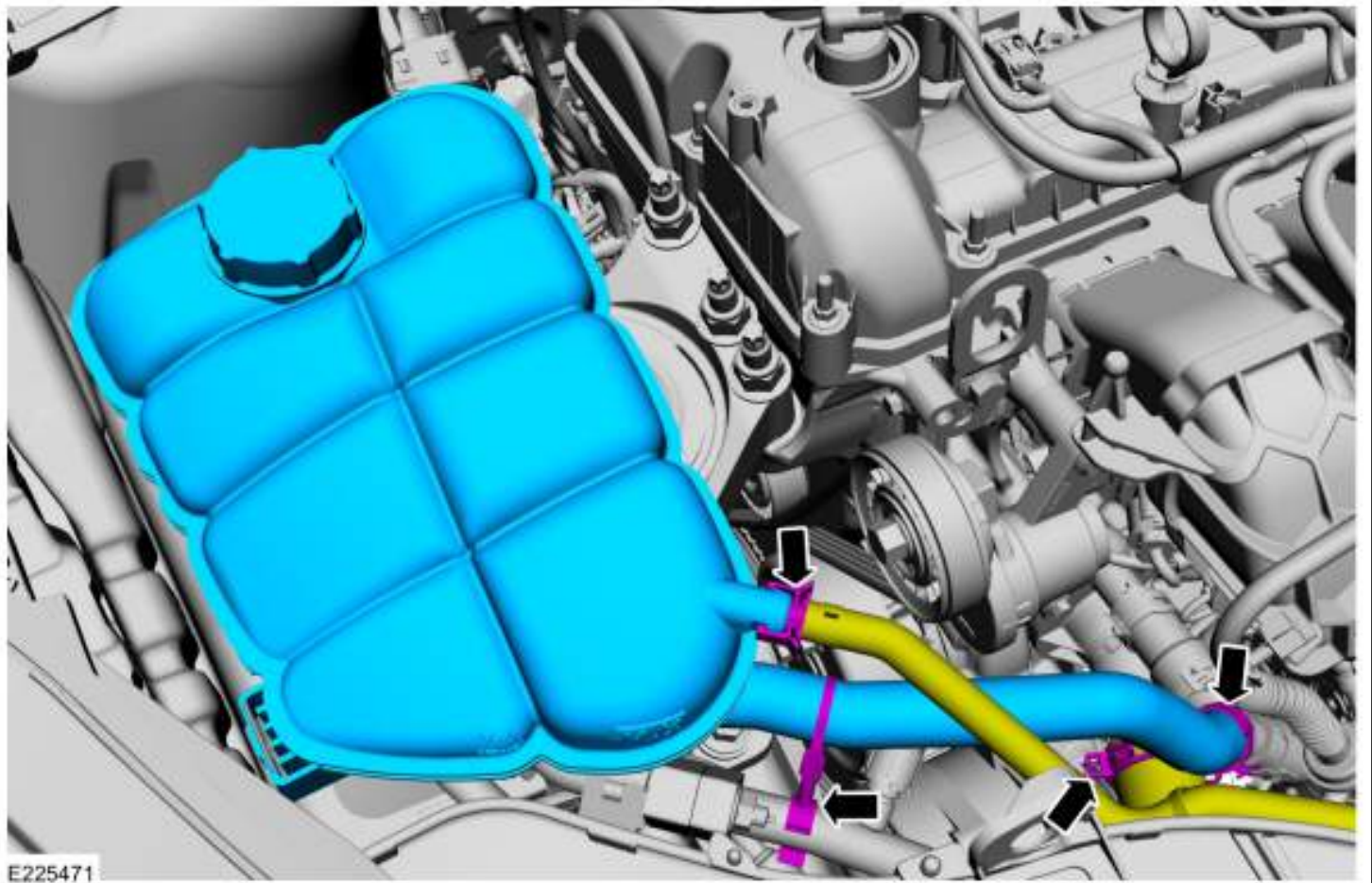

E225471

1. Use the General Equipment: Hose Clamp Remover/Installer
2. Use the General Equipment: Hose Clamp Remover/Installer
3. Refer to: Quick Release Coupling (310-00I) .

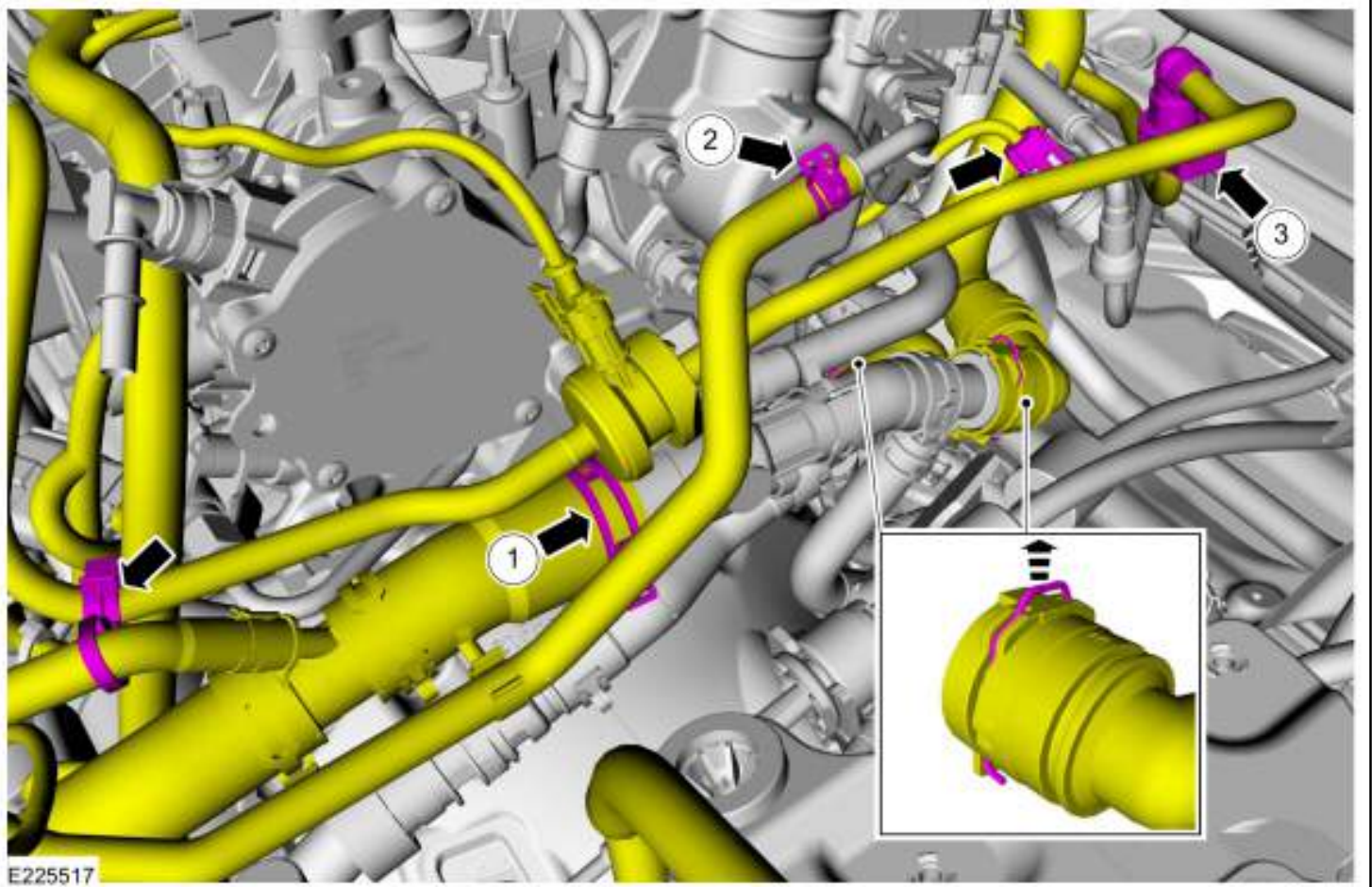

1. *Torque:* 106 lb.in (12 Nm)
2. *Torque:* 159 lb.in (18 Nm)



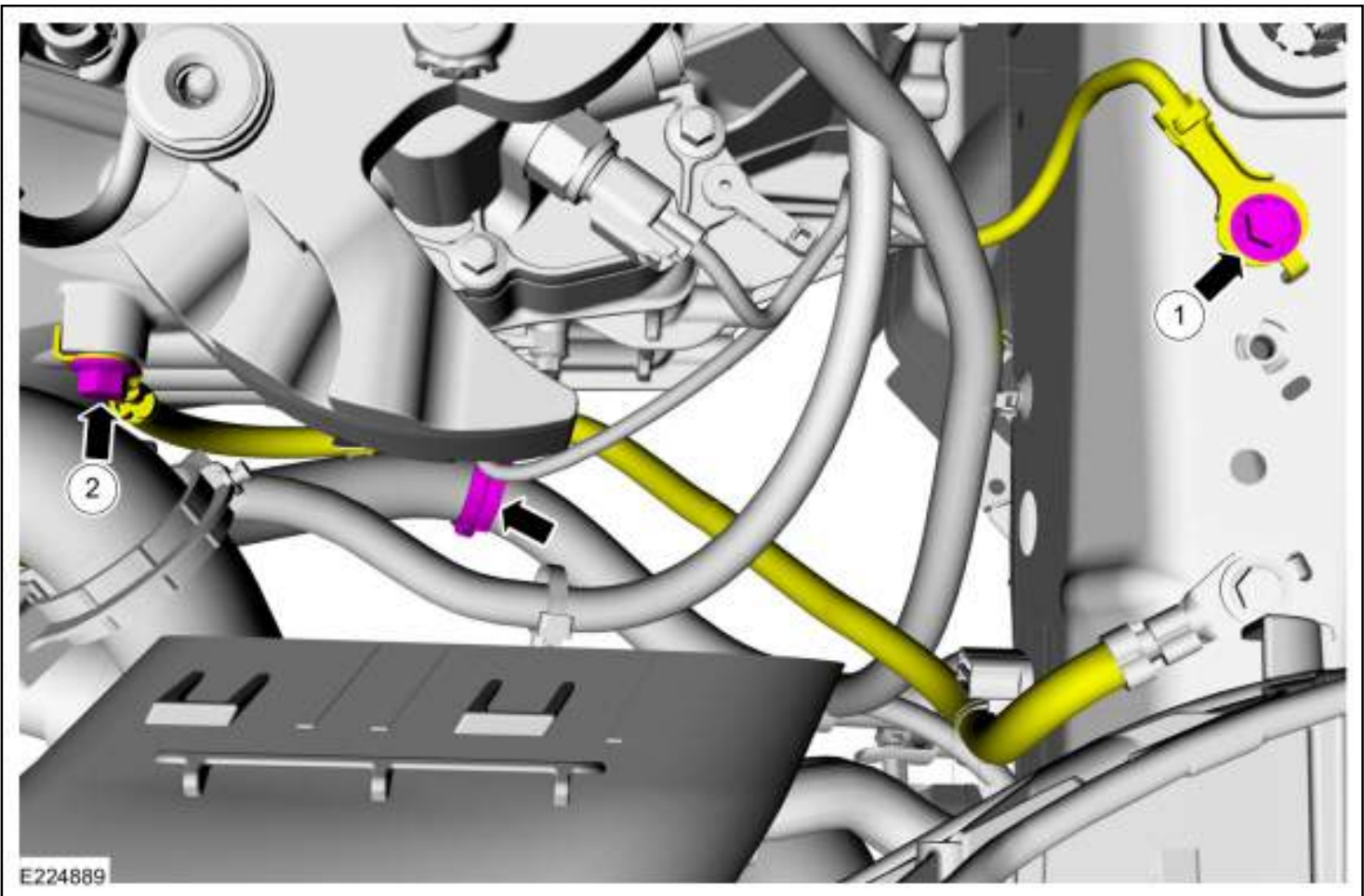

34. *Torque:* 106 lb.in (12 Nm)

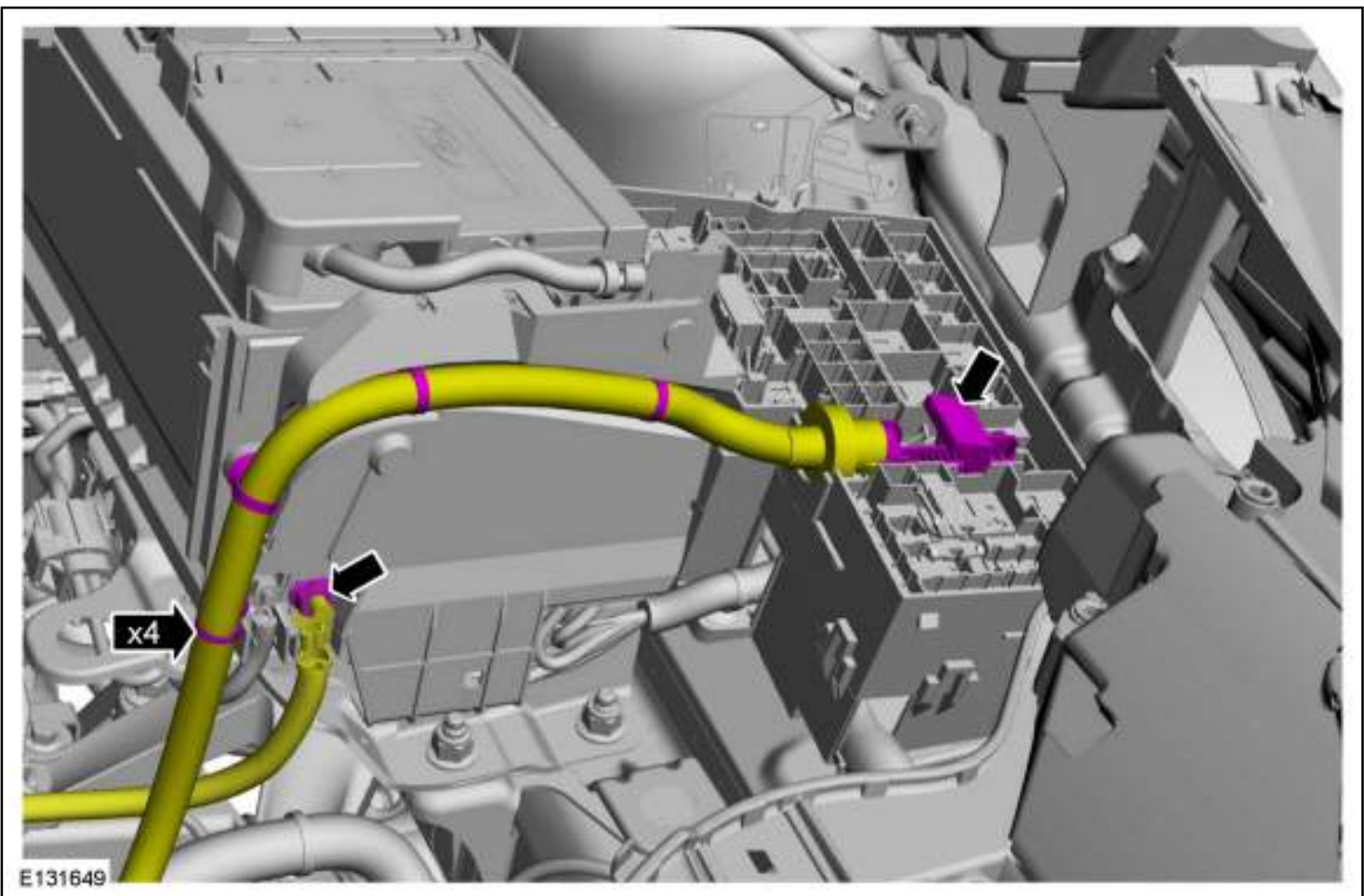

35.

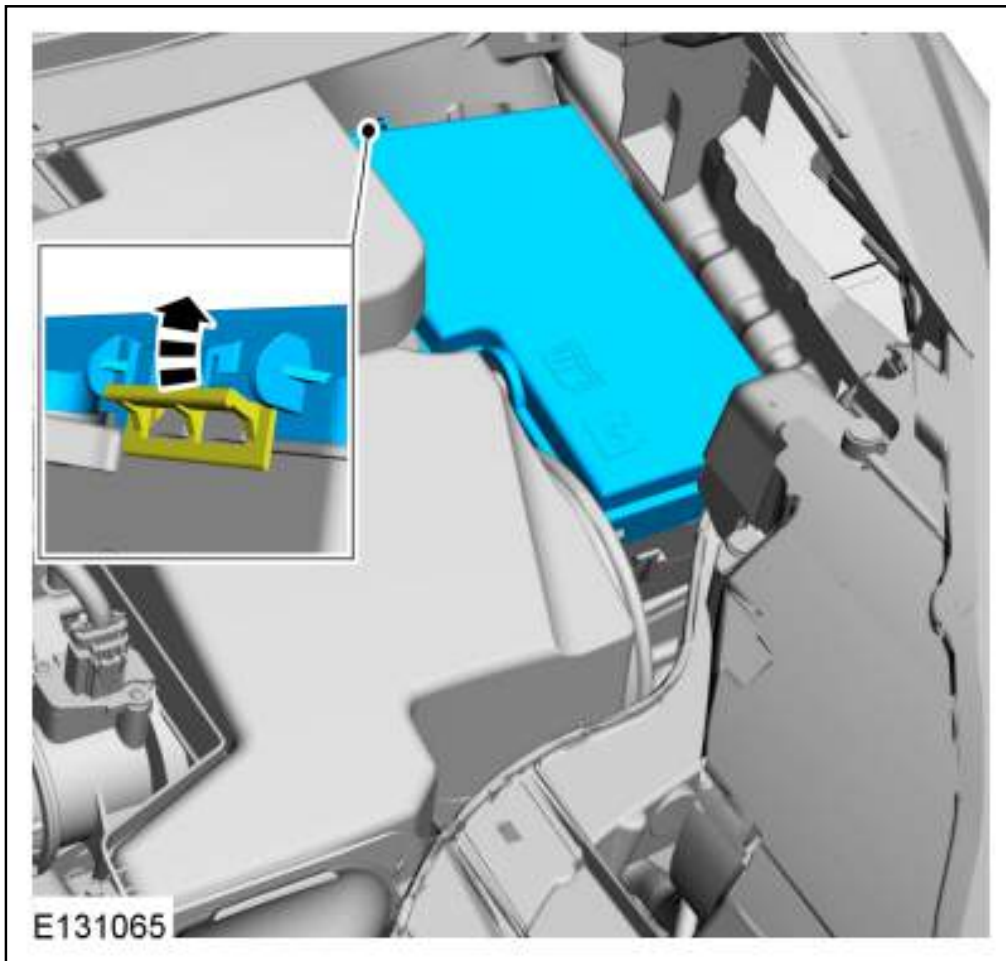

36. Install the following items:





1. Refer to: Catalytic Converter (309-00G) .
2. Refer to: Cooling Fan Motor and Shroud (303-03H) .
3. Refer to: Air Conditioning (A/C) Compressor Belt (303-05H) .

37. Refer to: Cooling System Draining and Vacuum Filling (303-03H) .

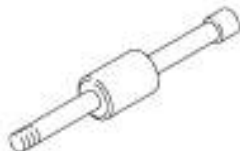

## Engine Accessories

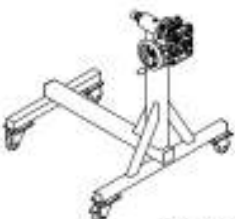
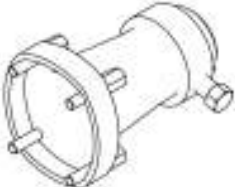
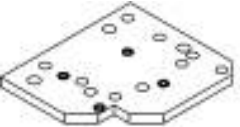
### Special Tool(s) / General Equipment

 15011	205-047 Slide Hammer
 E158911	205-047-08 Adapter for 205-047
 E252718	303-435 Mounting Stand
 E252723	303-435-06 Mounting Bracket for 303-435
 E68386	303-435-11B Mounting Plate for 303-435-06
 E168032	310-206 Remover, Fuel Injector TKIT-2009A-FLM
Lifting Bracket	

Floor Crane

Hose Clamp Remover/Installer

Knife

1.

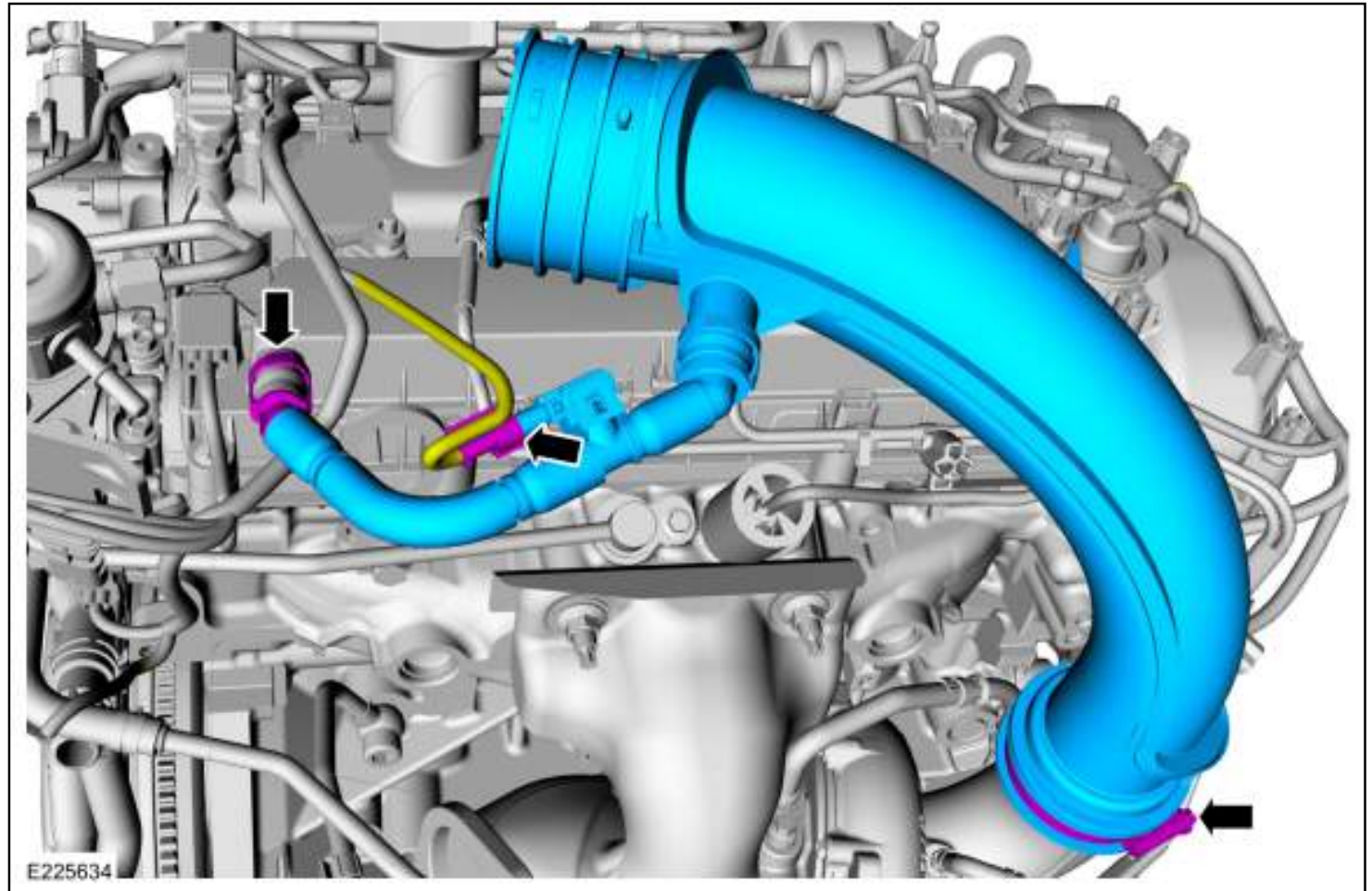

1. Use the General Equipment: Hose Clamp Remover/Installer

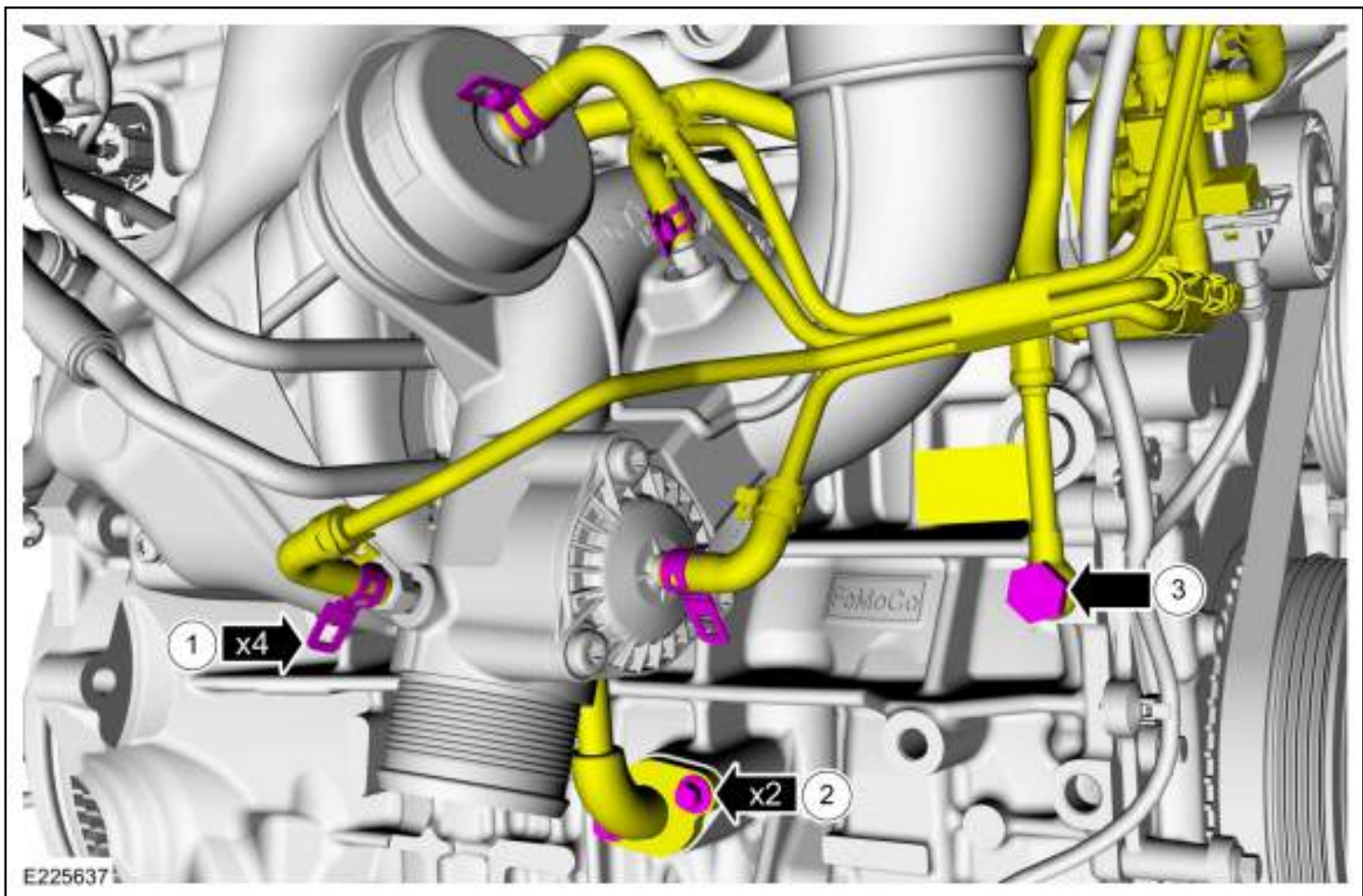

1. Use the General Equipment: Hose Clamp Remover/Installer

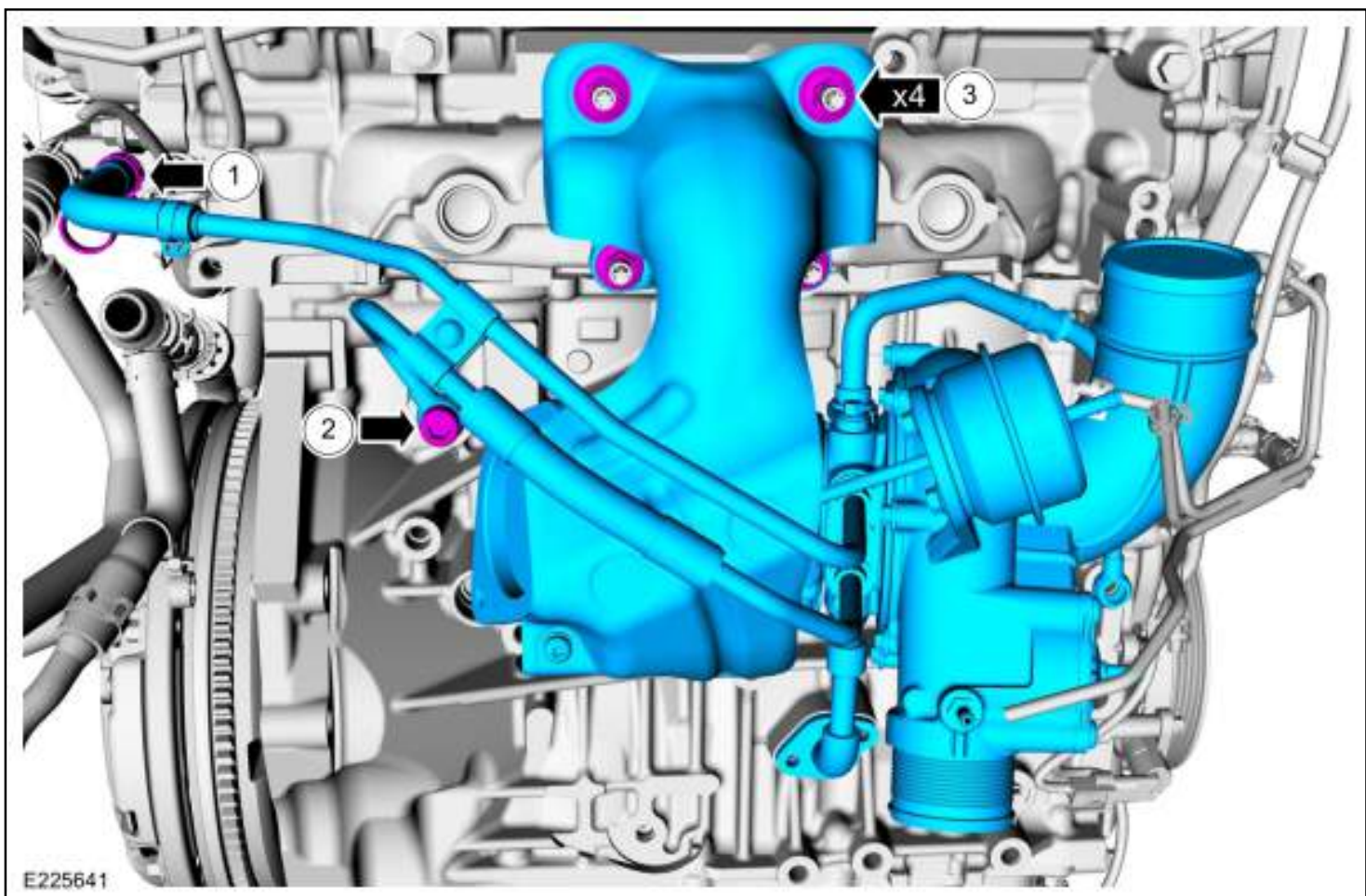

4. Remove the following items:
- Use the General Equipment: Lifting Bracket
  - Use the General Equipment: Floor Crane

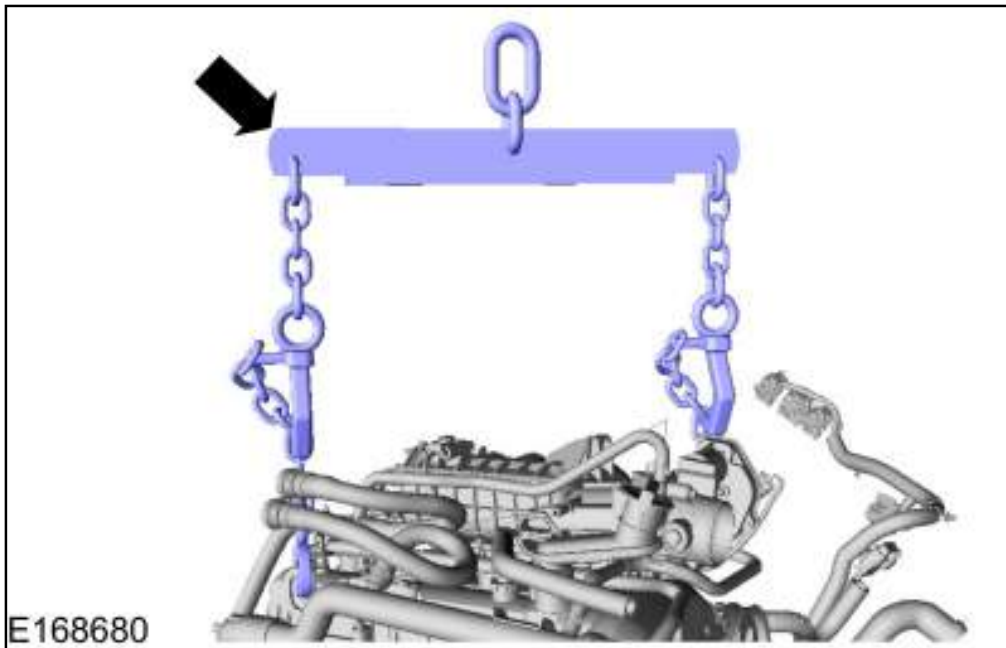

5. Install Special Service Tool: 303-435 Mounting Stand. , 303-435-11B Mounting Plate for 303-435-06. , 303-435-06 Mounting Bracket for 303-435.

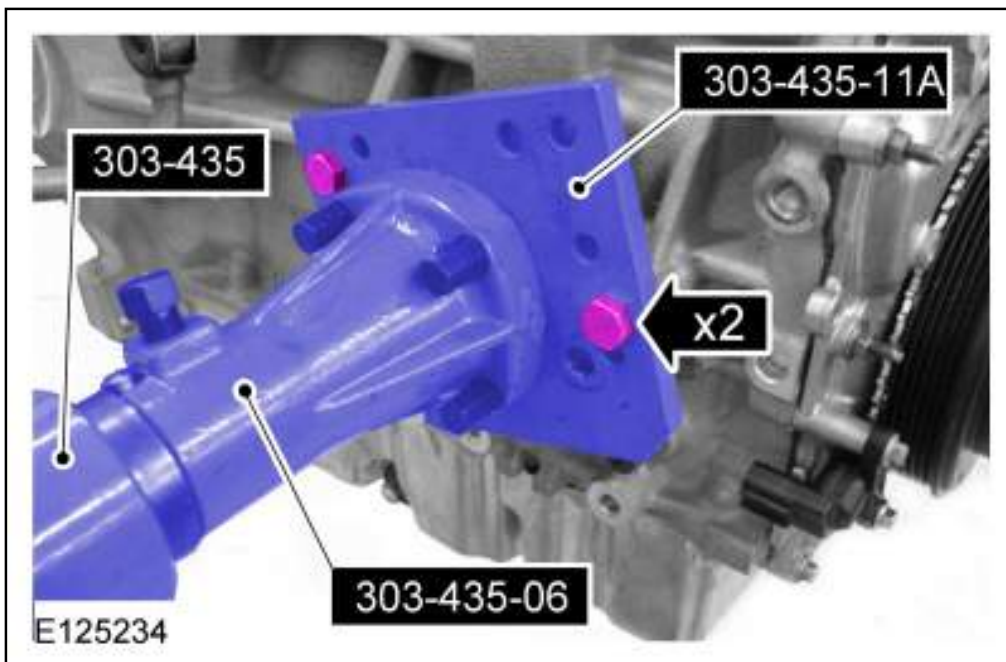

6.

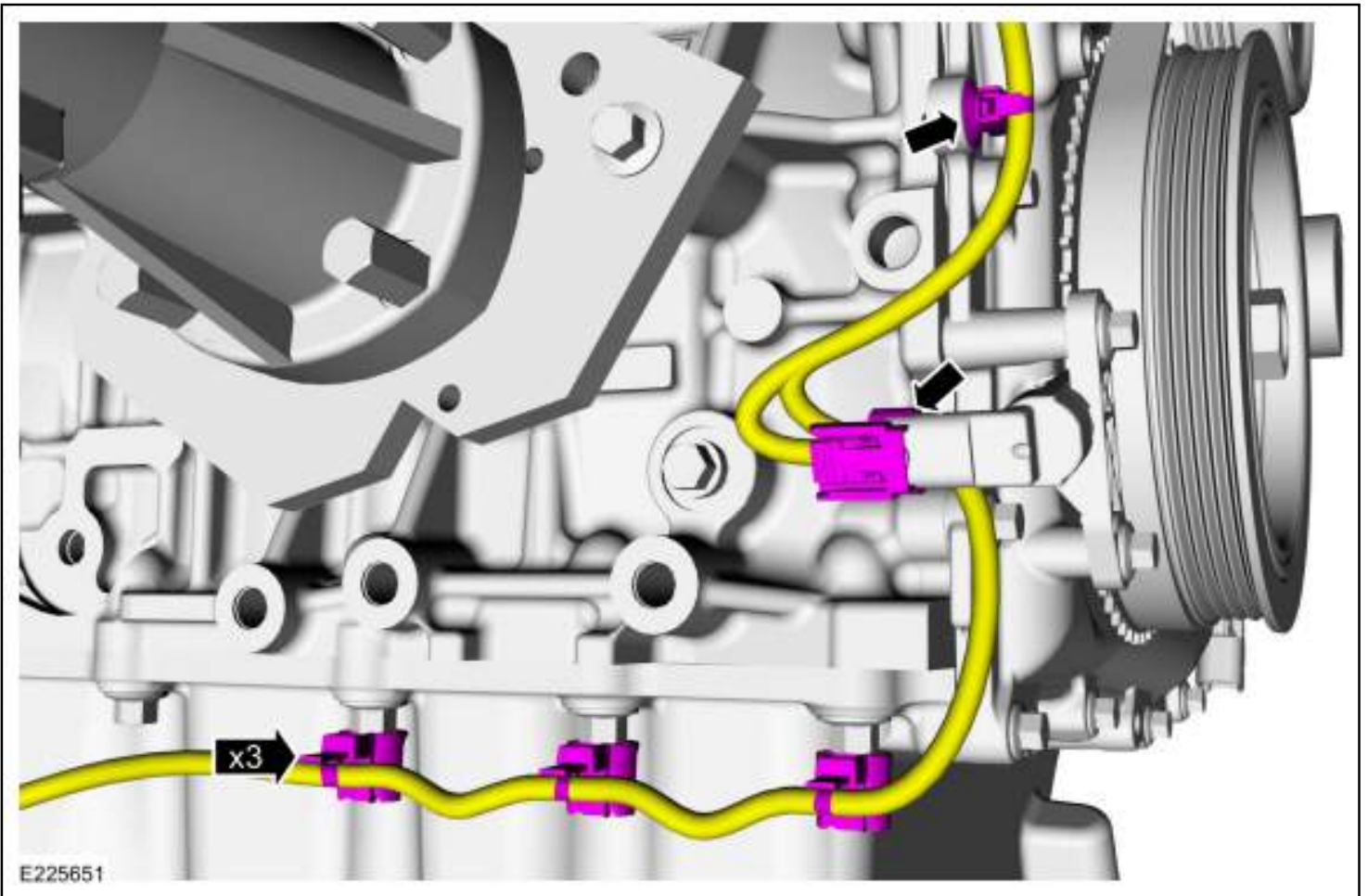

7.

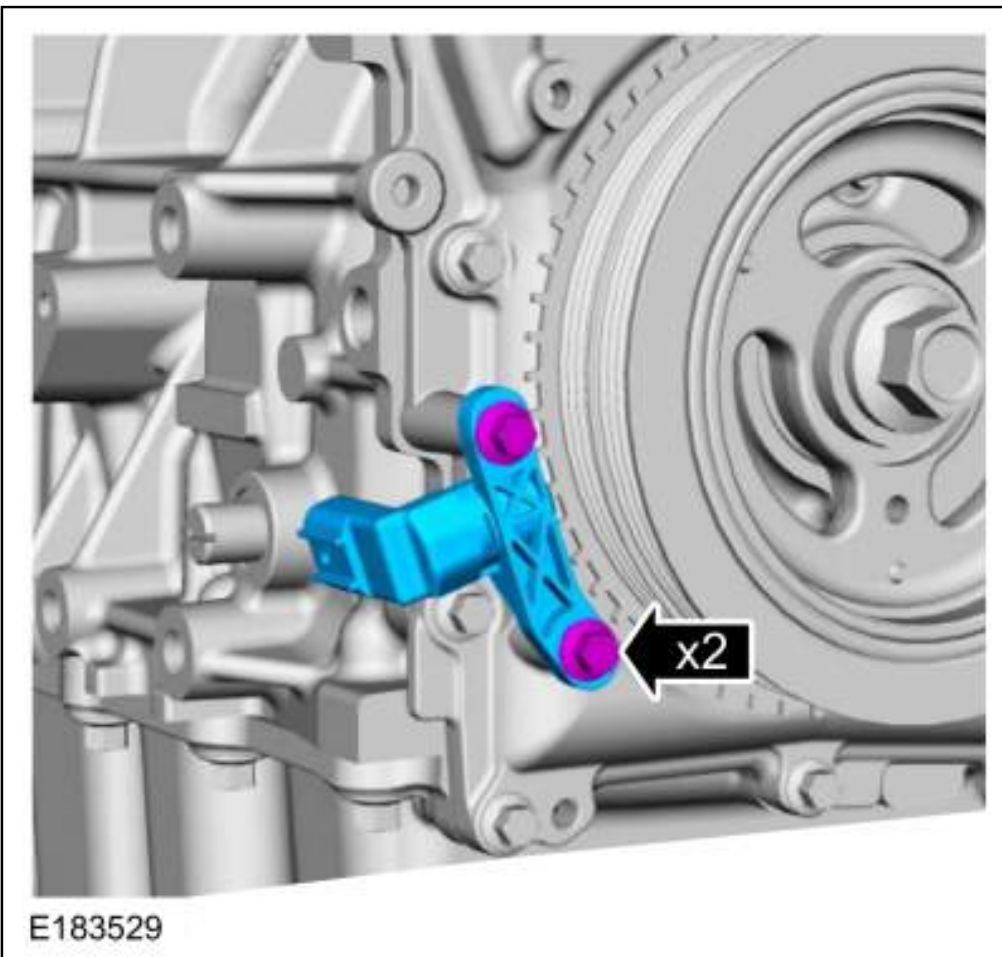

8.

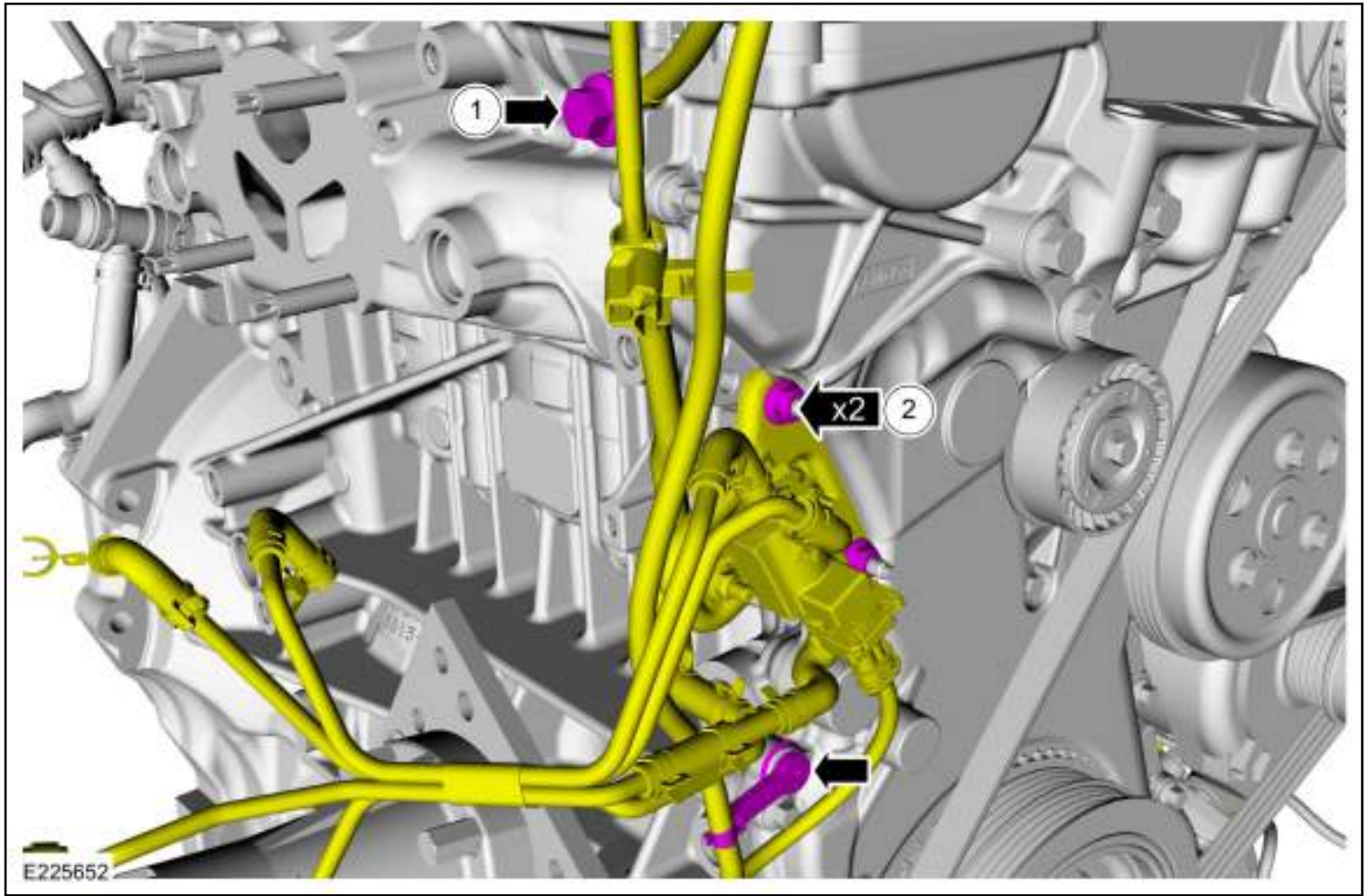

9.

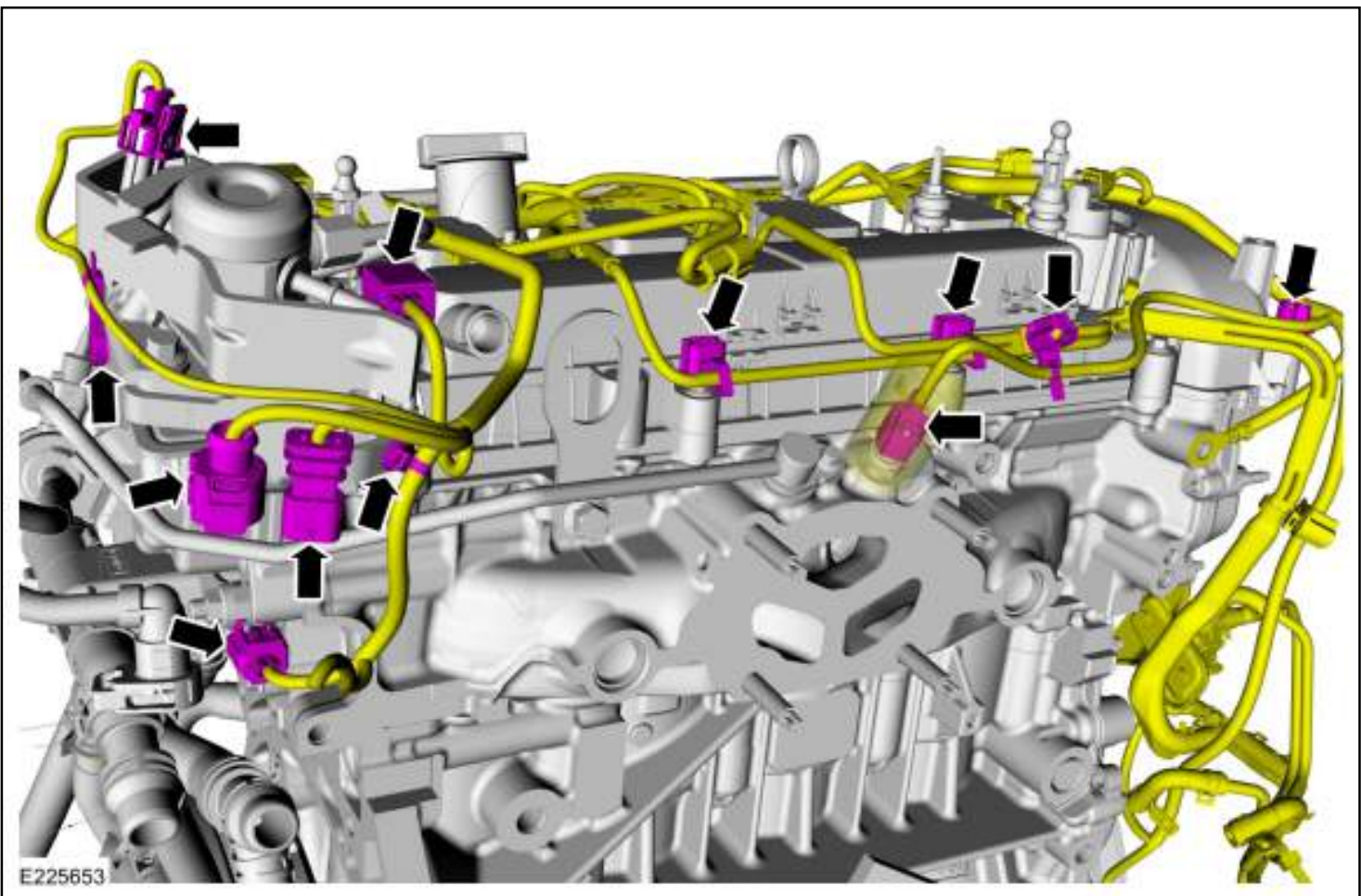

10.

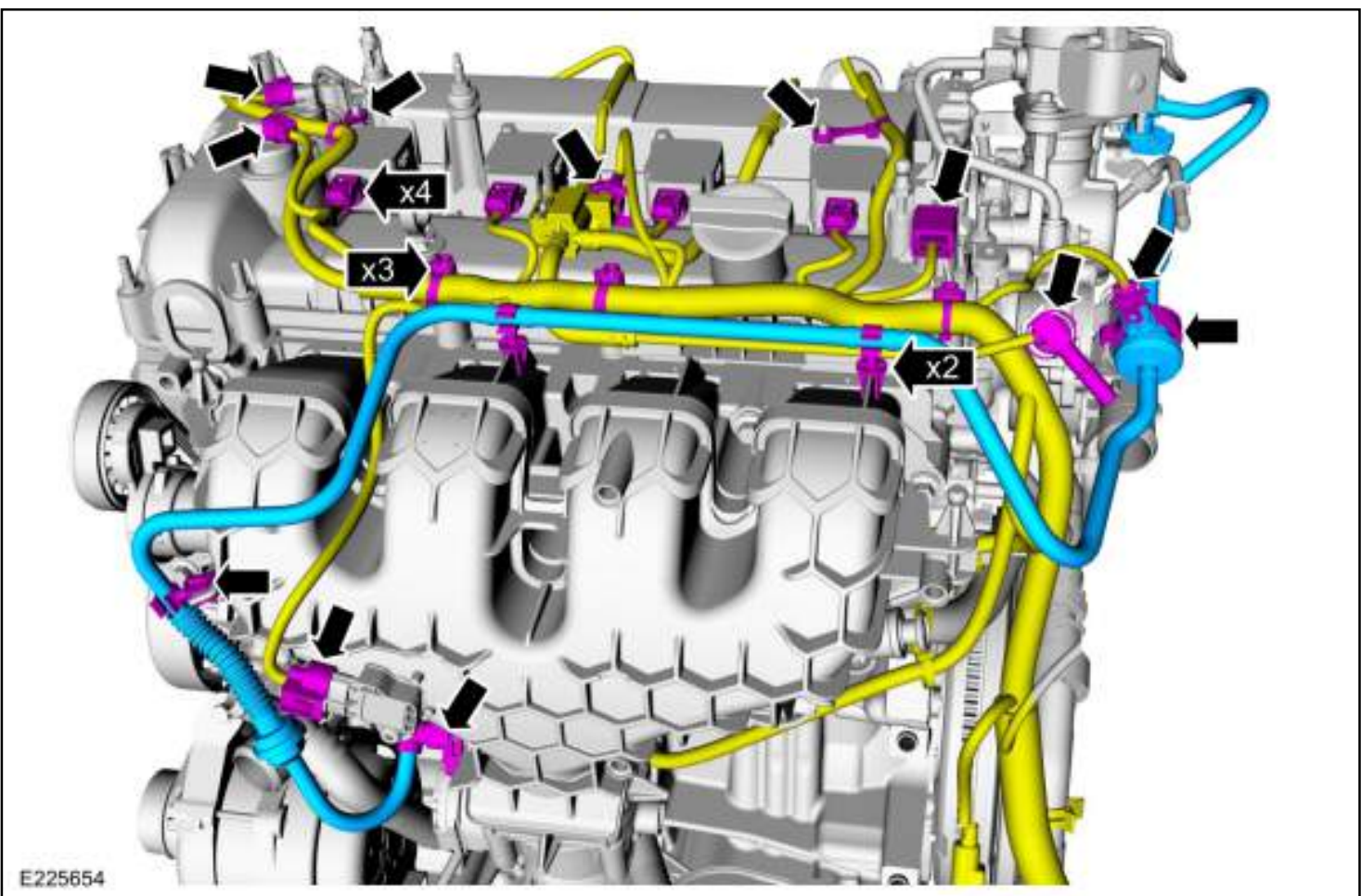

11.

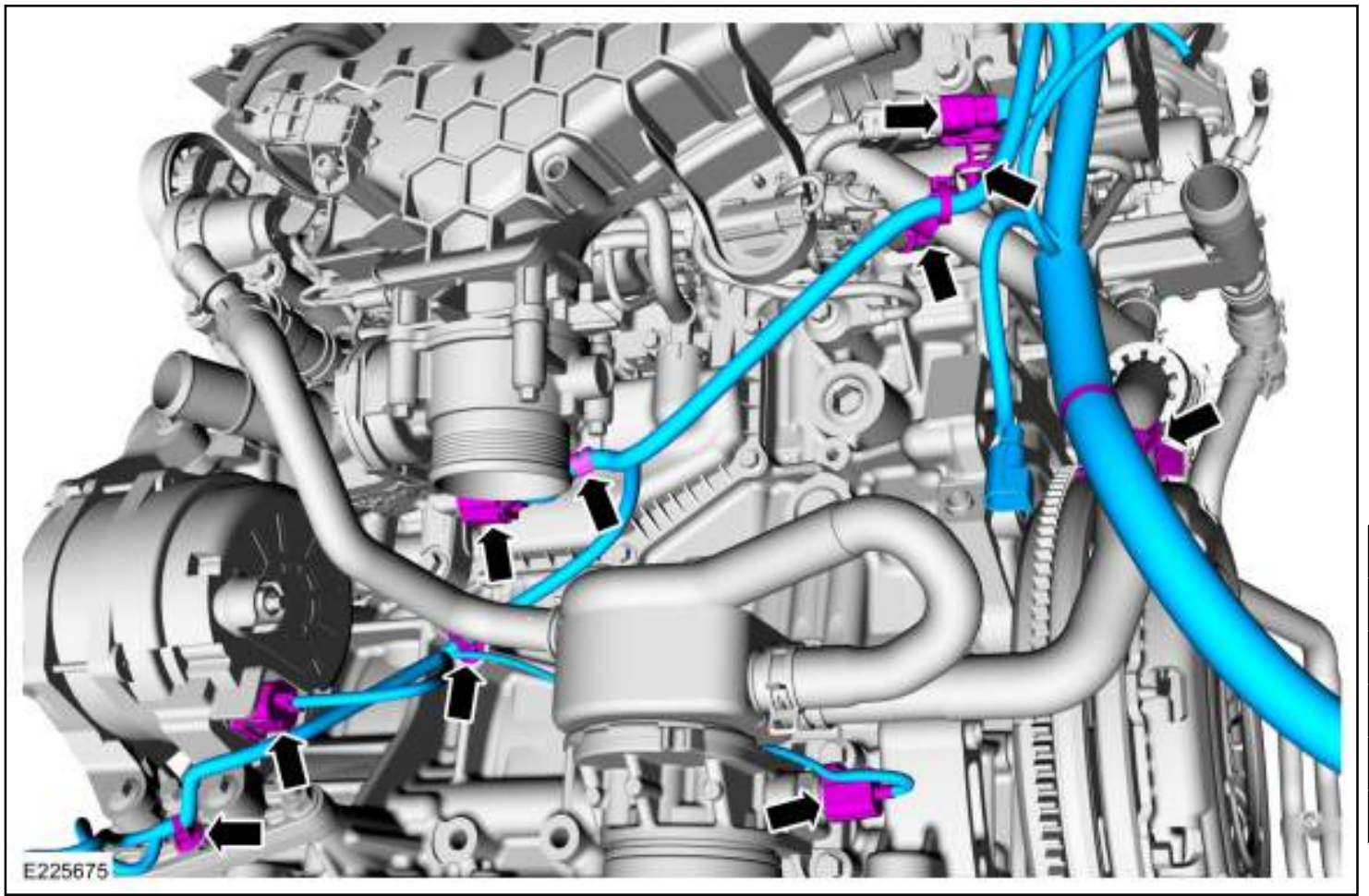

12.

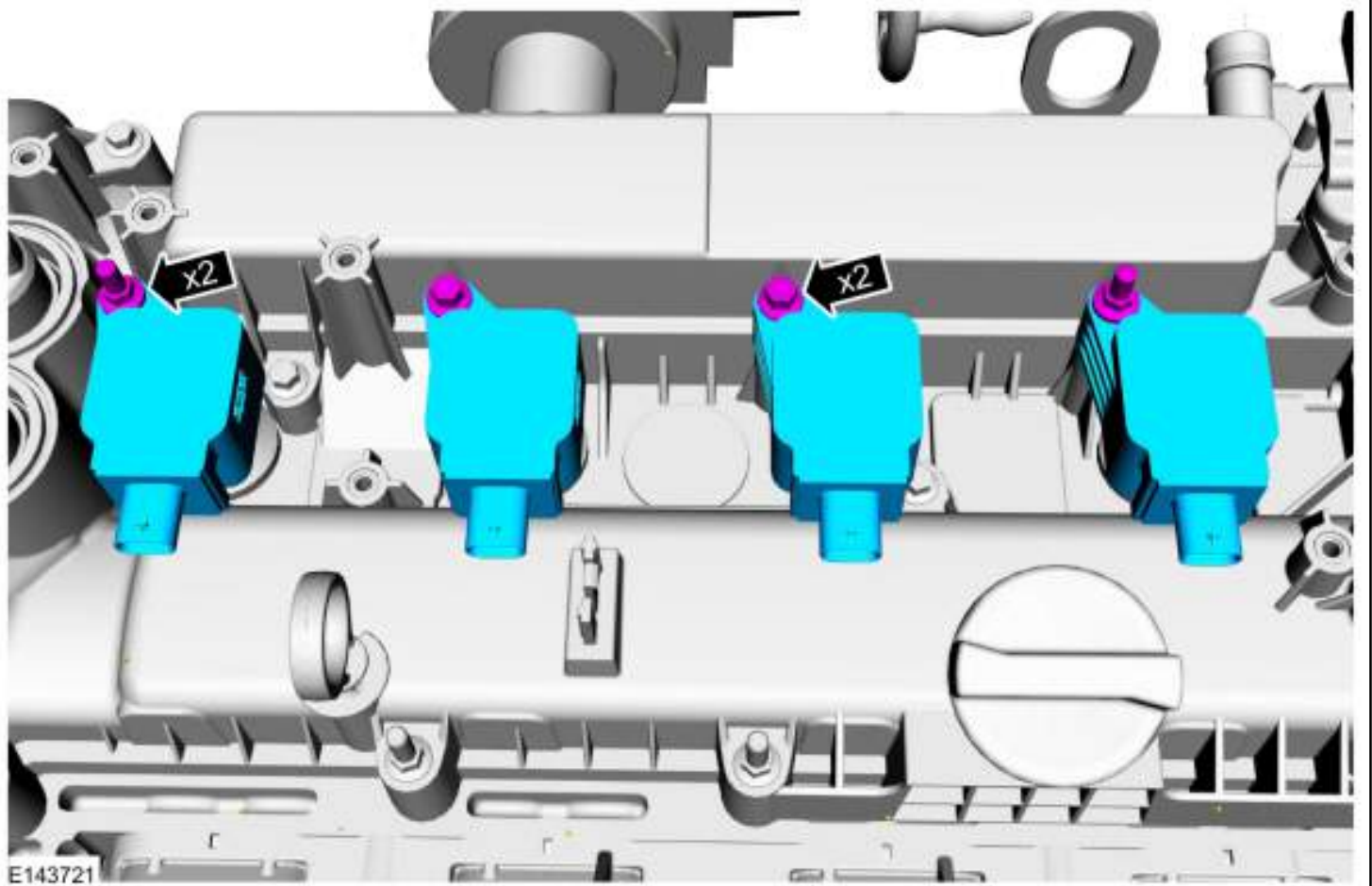

E143721



13.

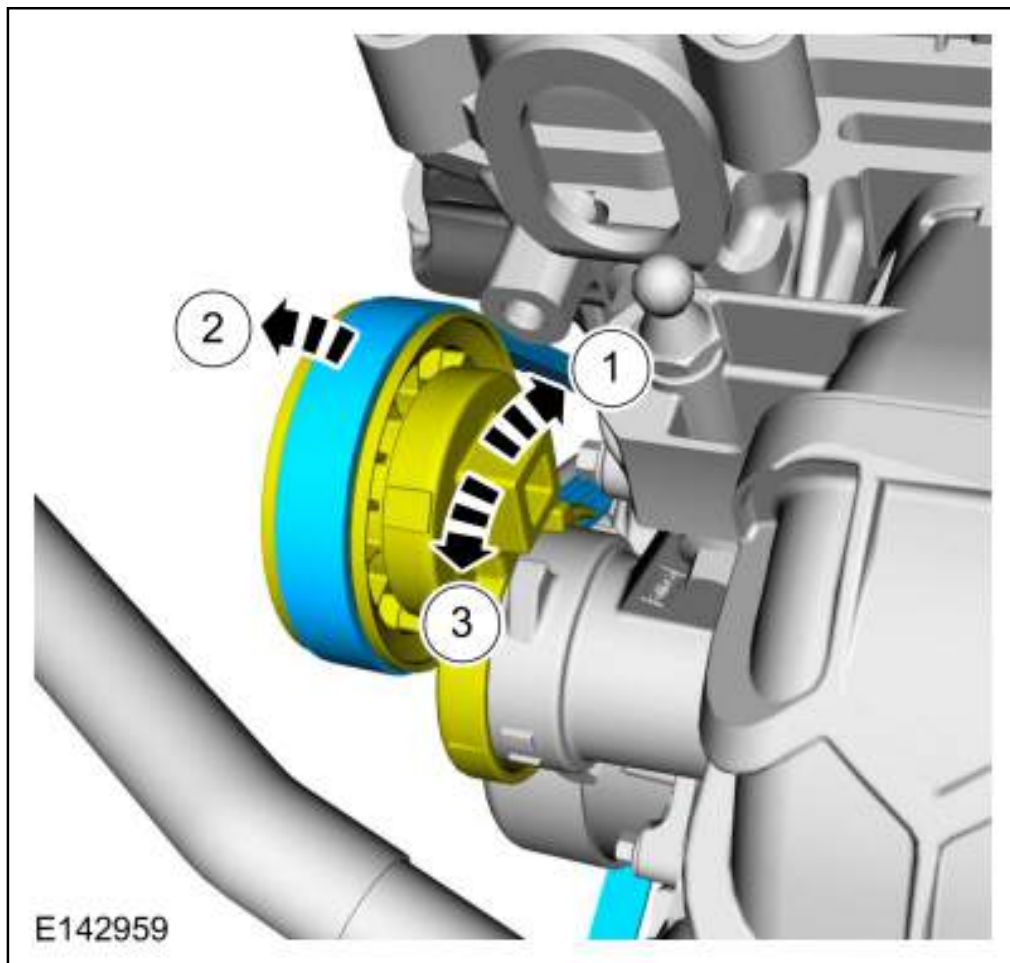

14.

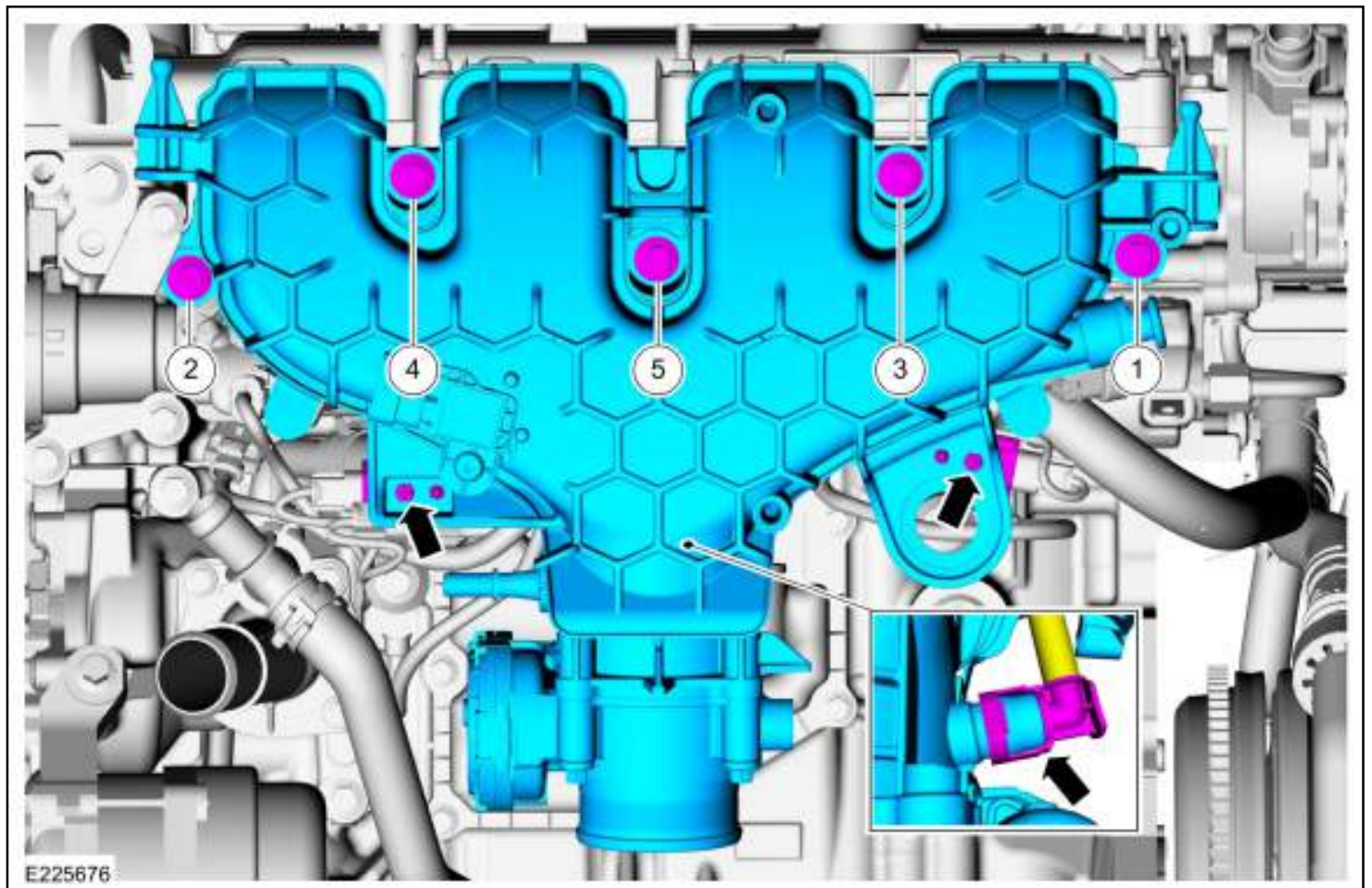

1. Use the General Equipment: Hose Clamp Remover/Installer

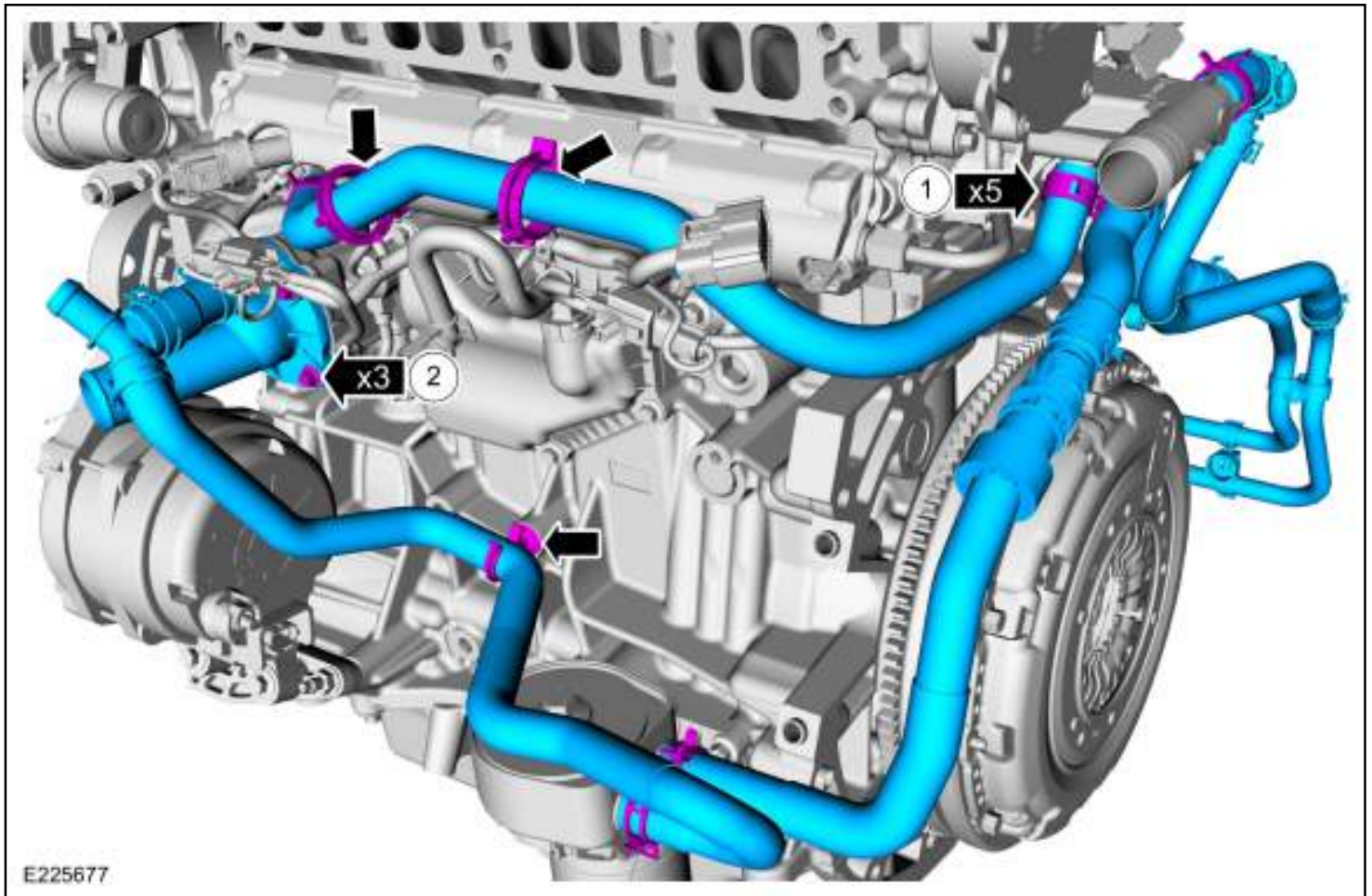

16.

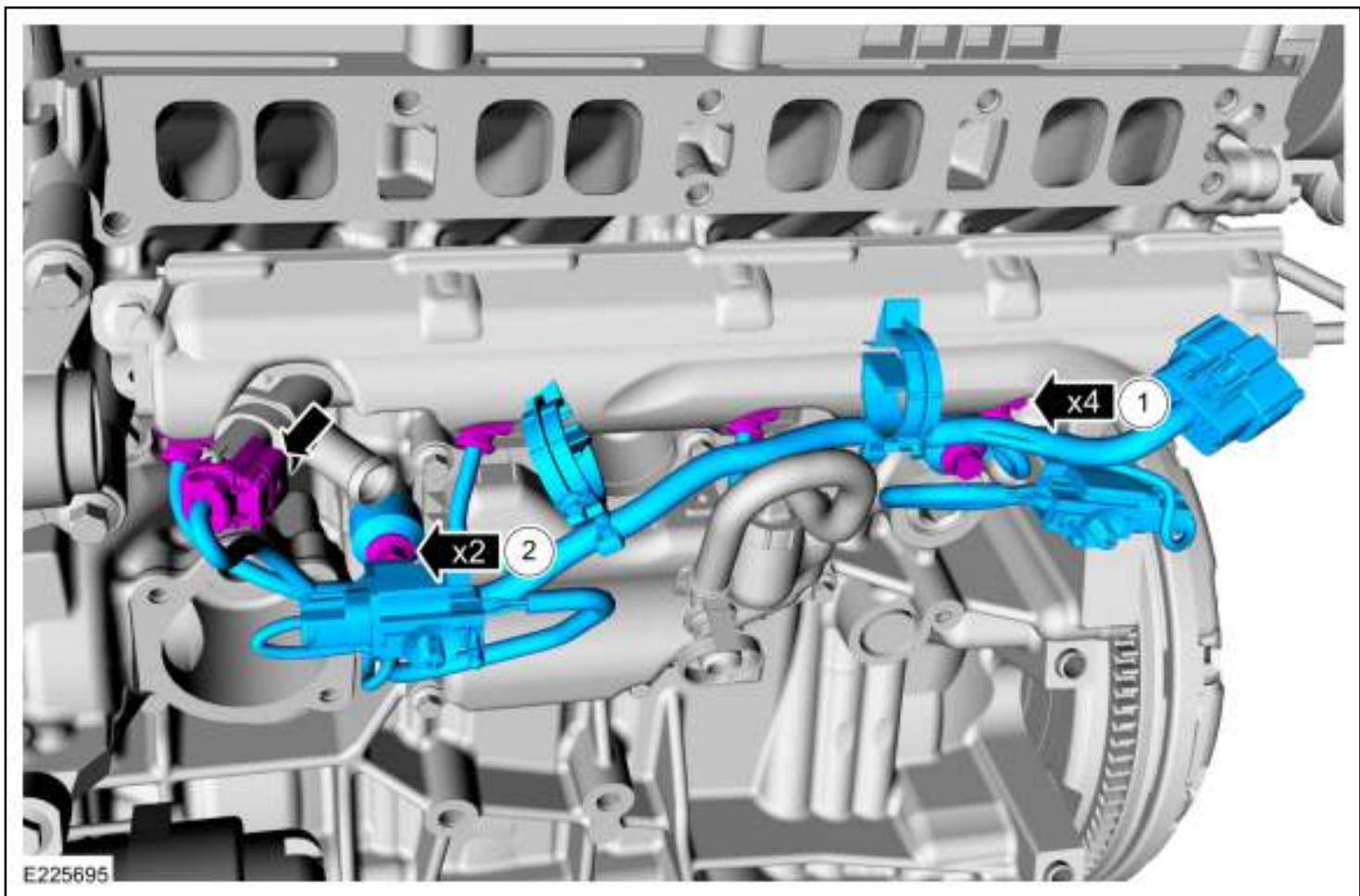

17.

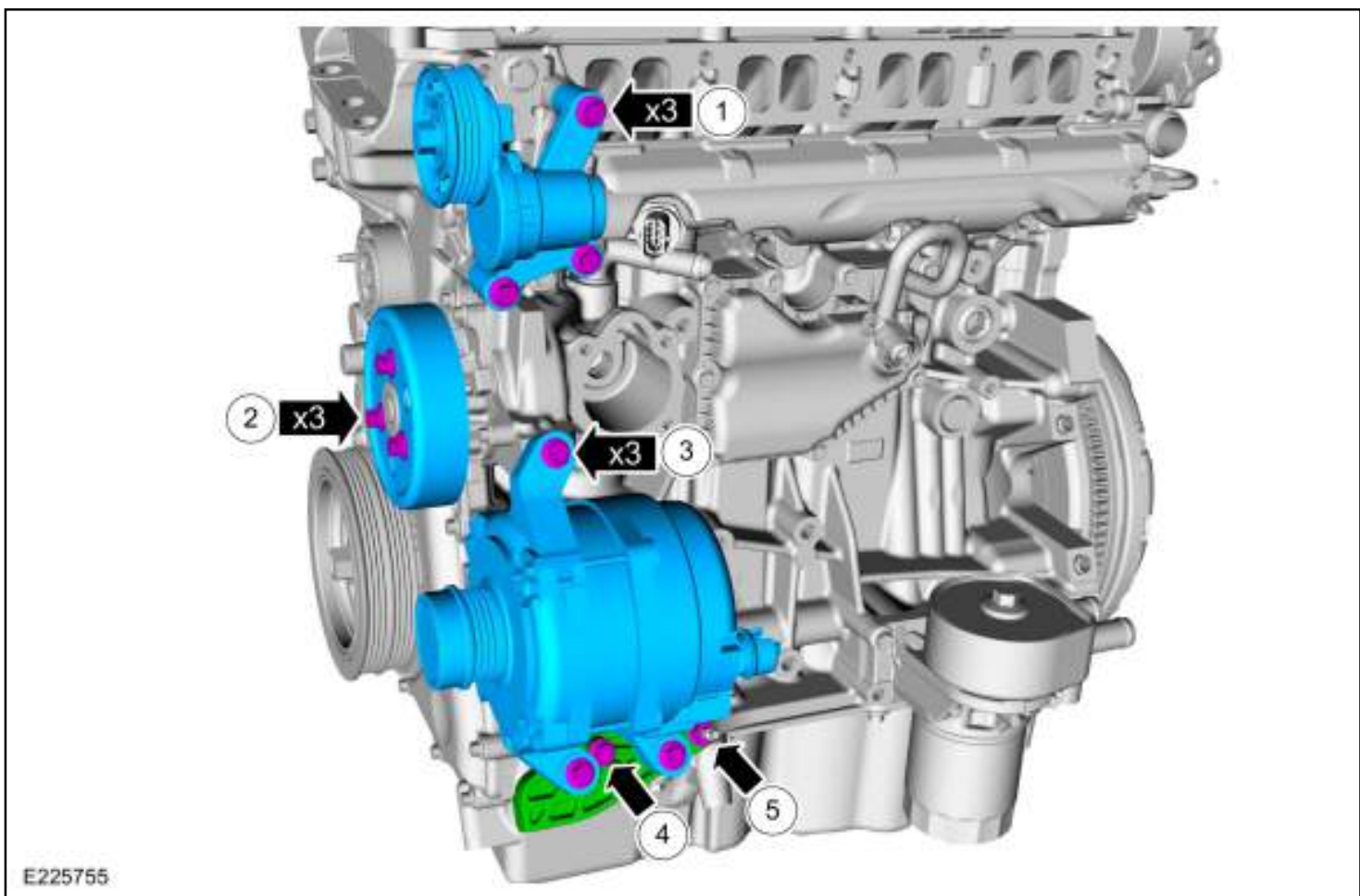

18.

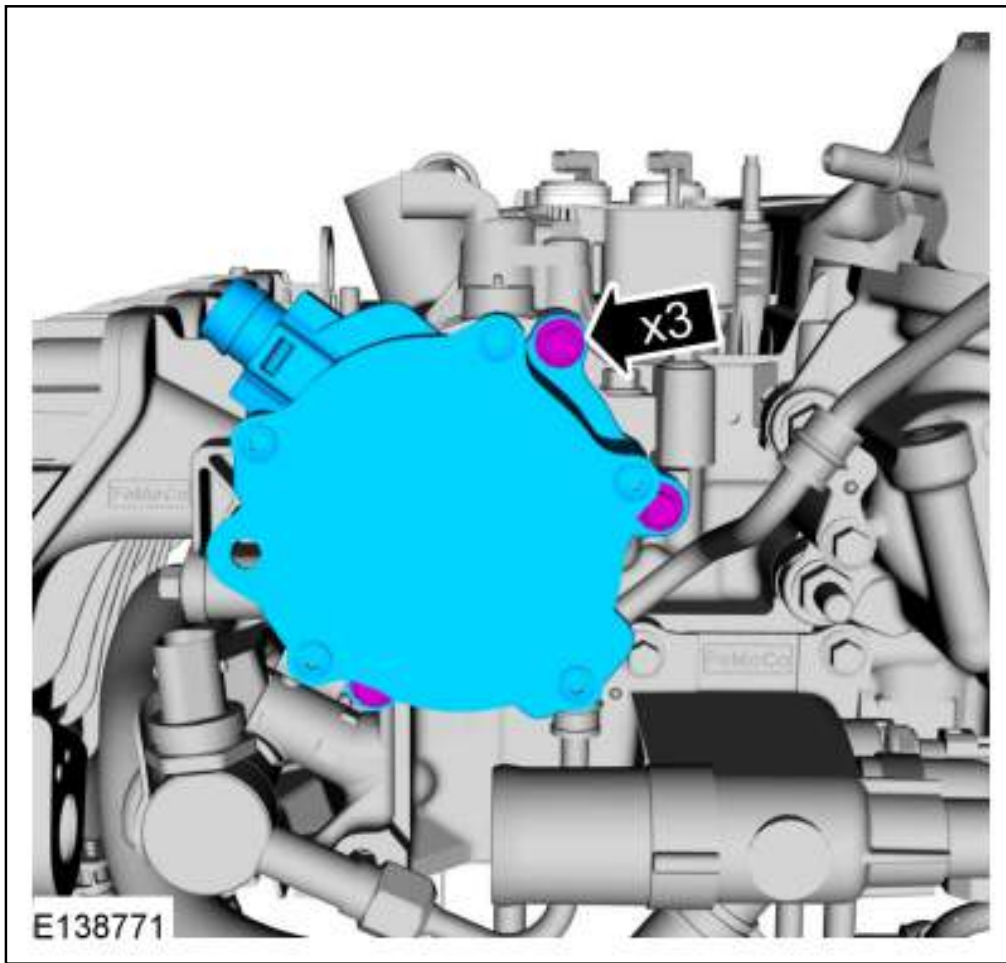

19.

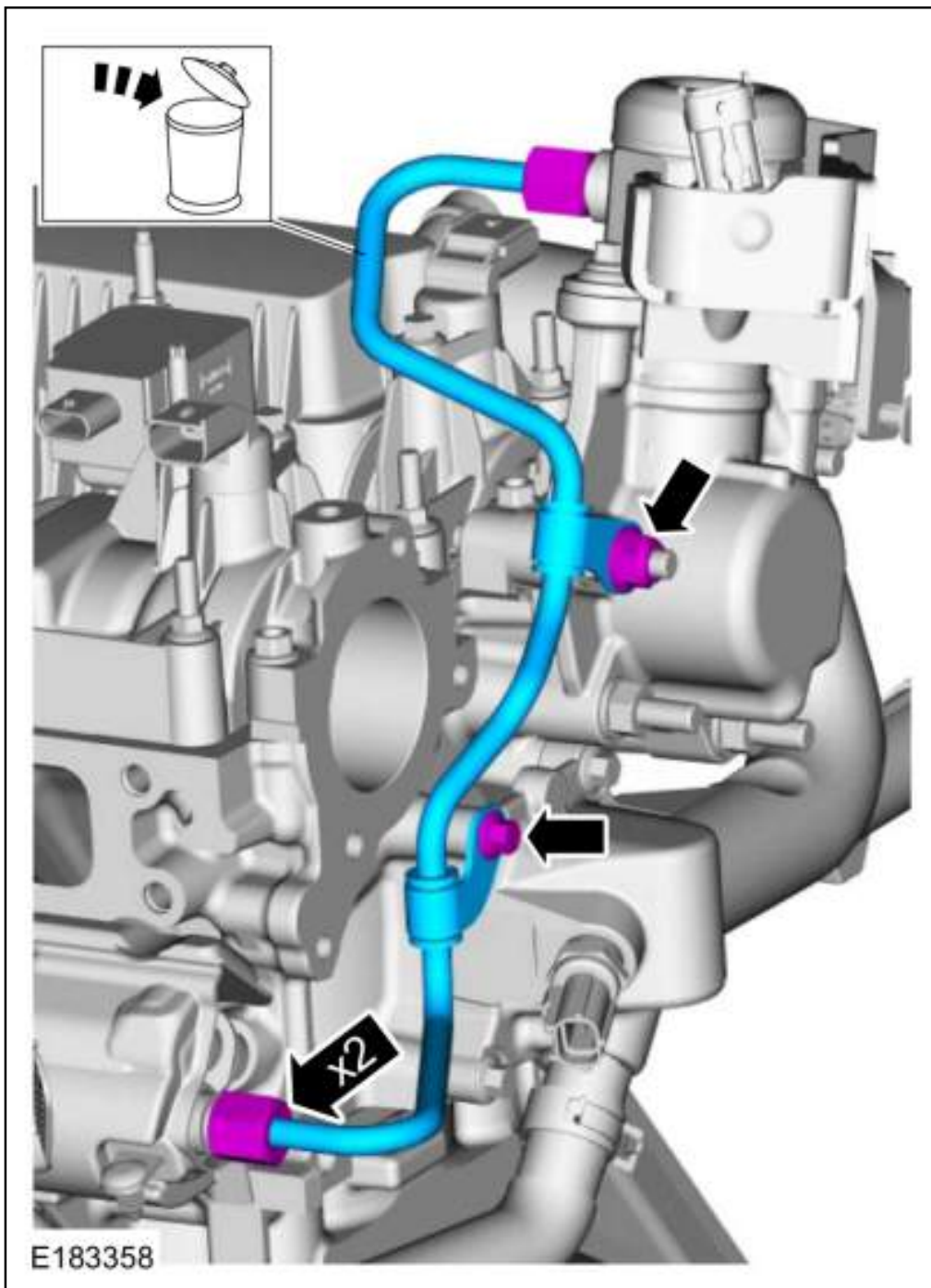

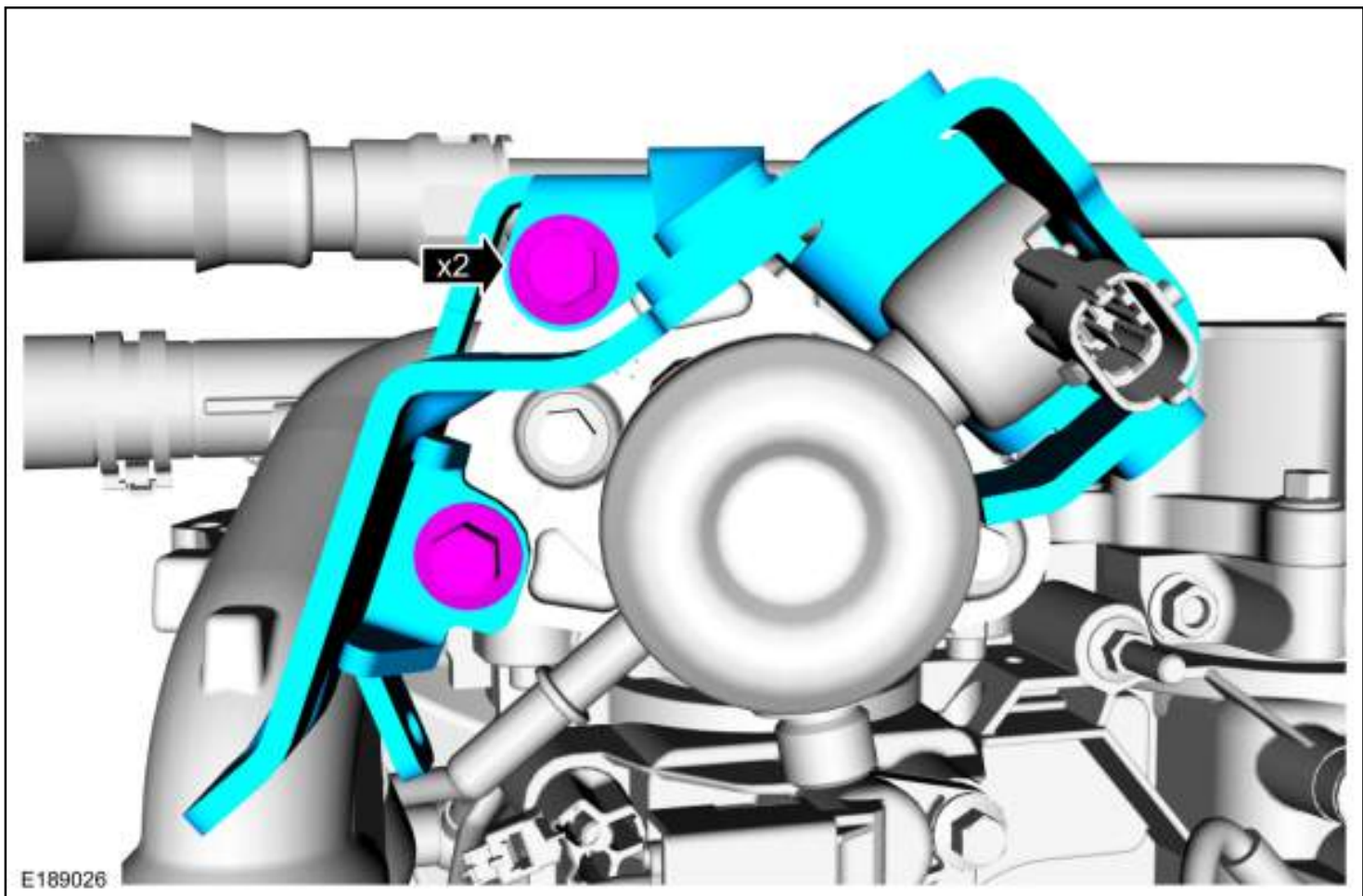

21. Loosen each bolt 2 turns at a time until all bolts are removed.

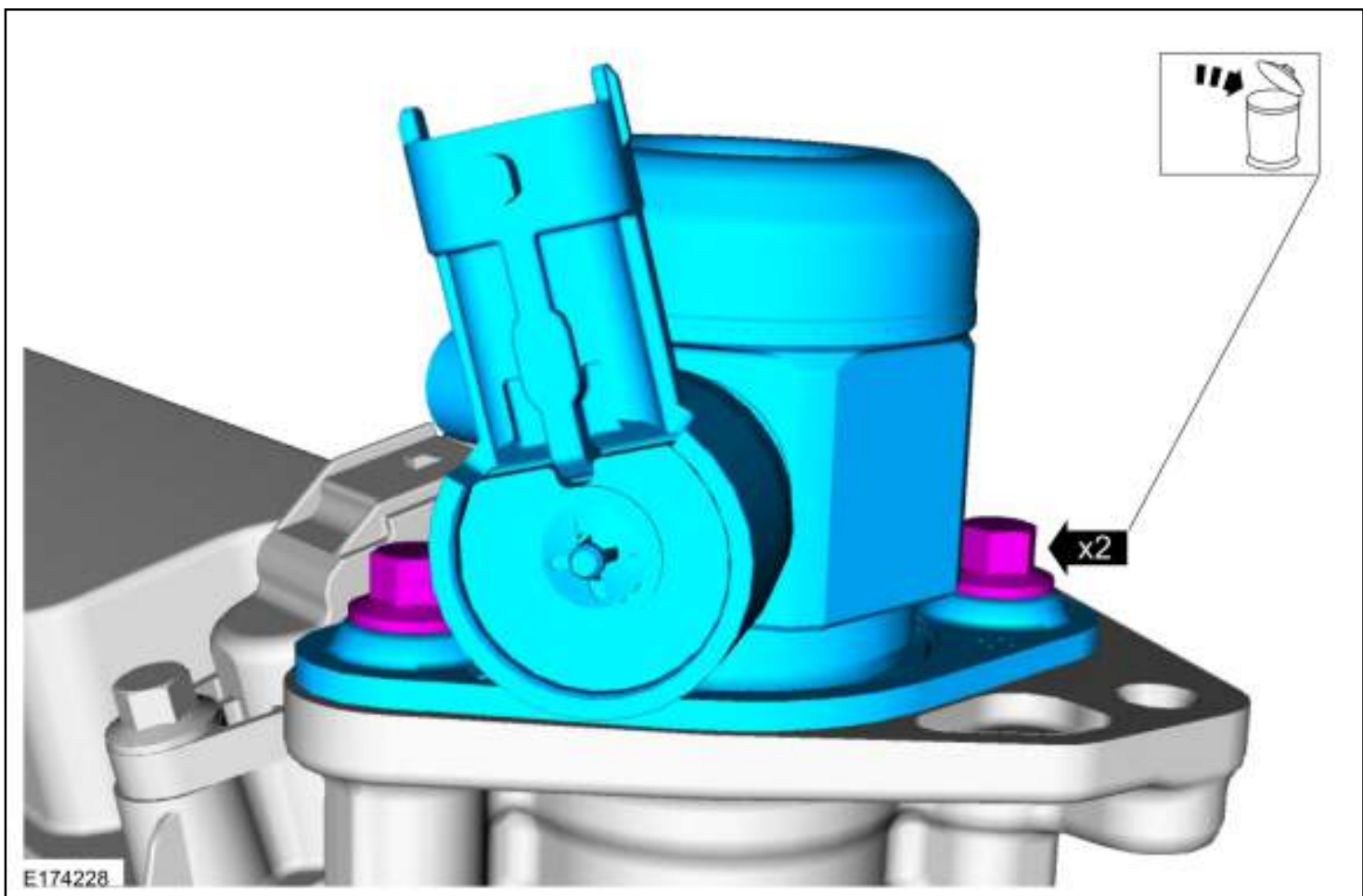

22.

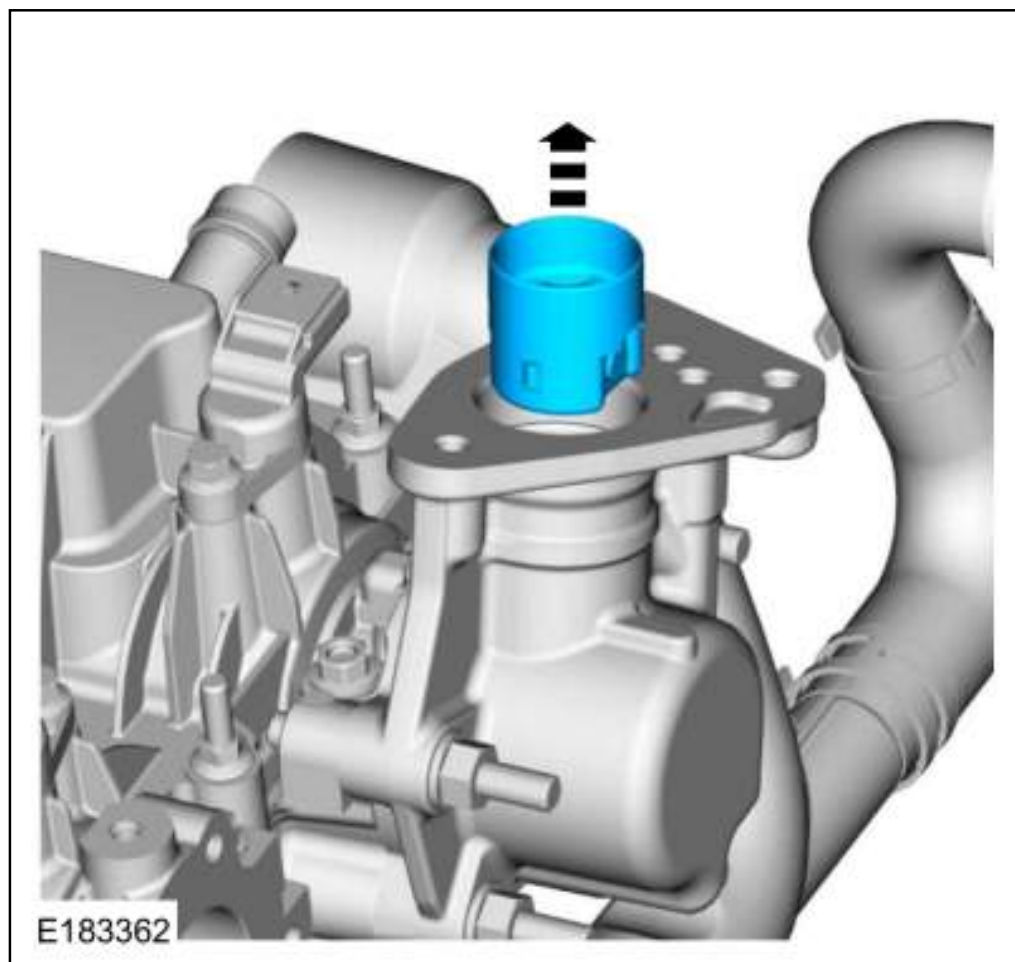

23.

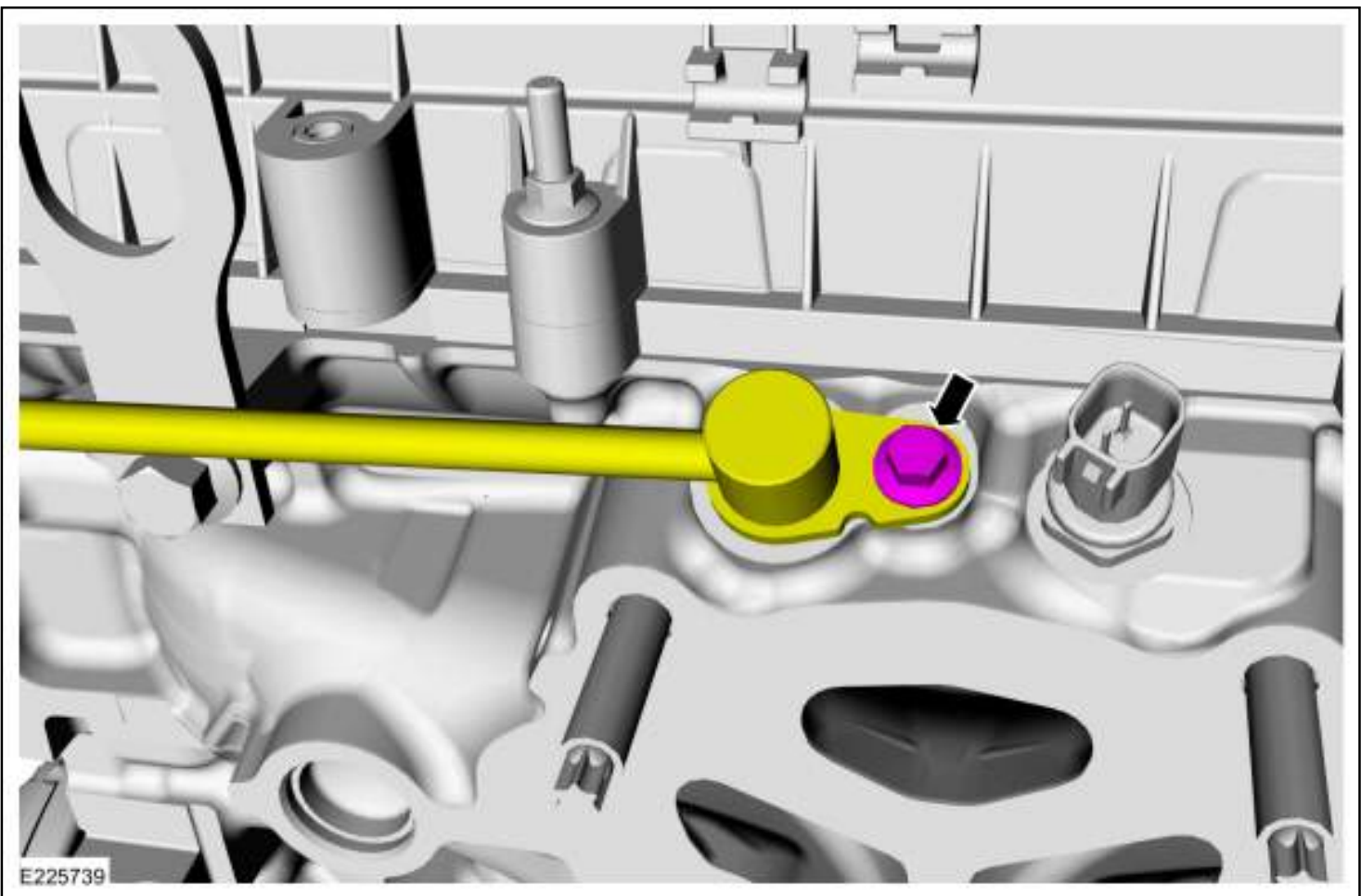

24.

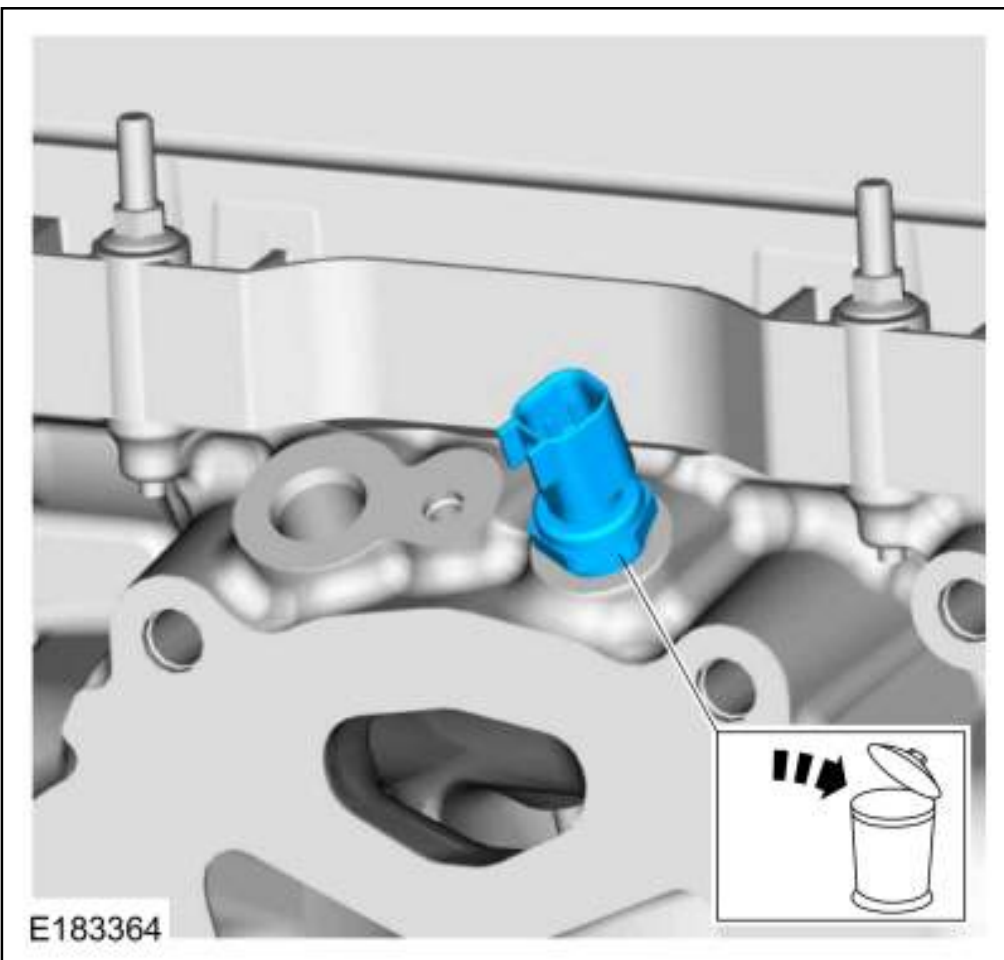

25.

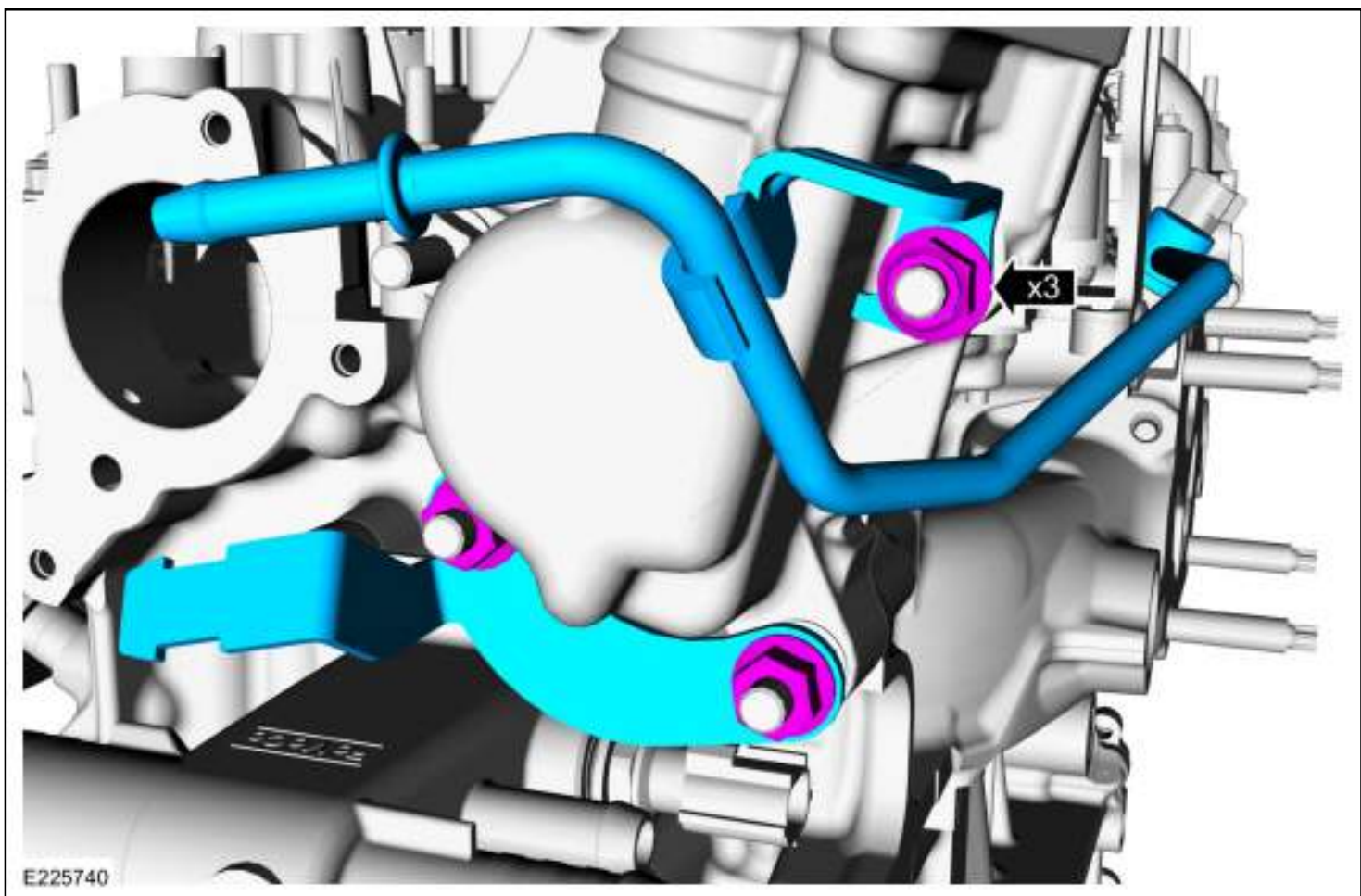

26.

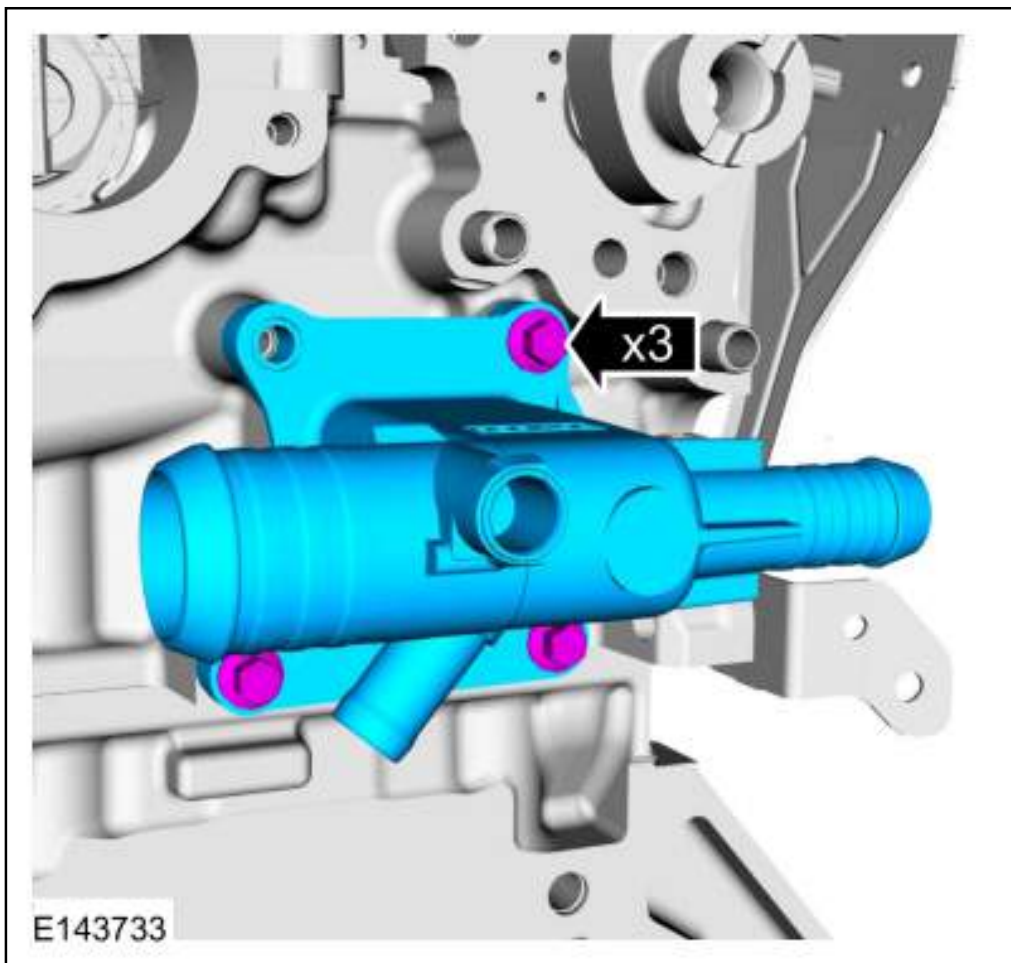

27.

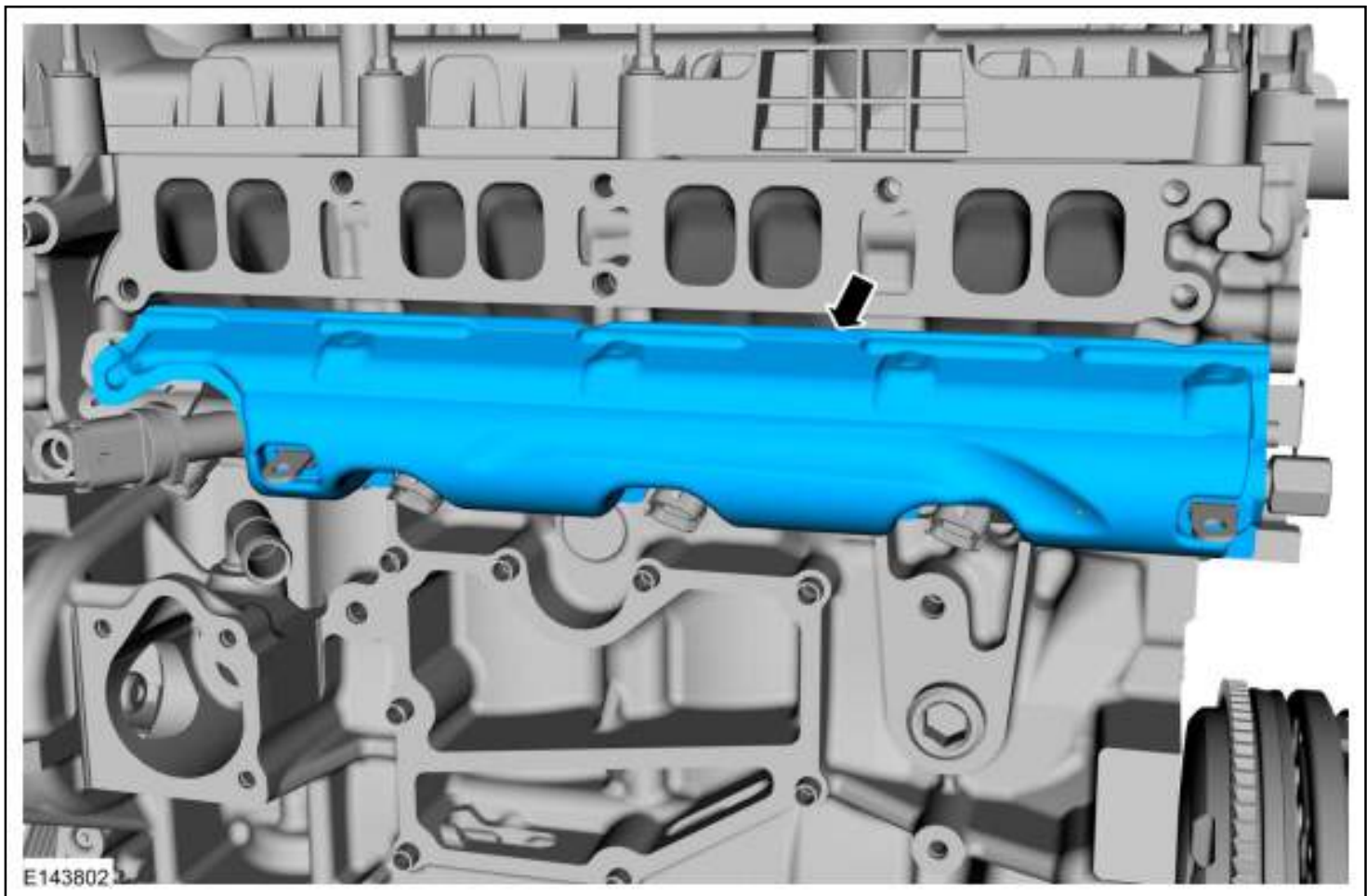

28. **NOTICE:** Take extra care when handling the components.

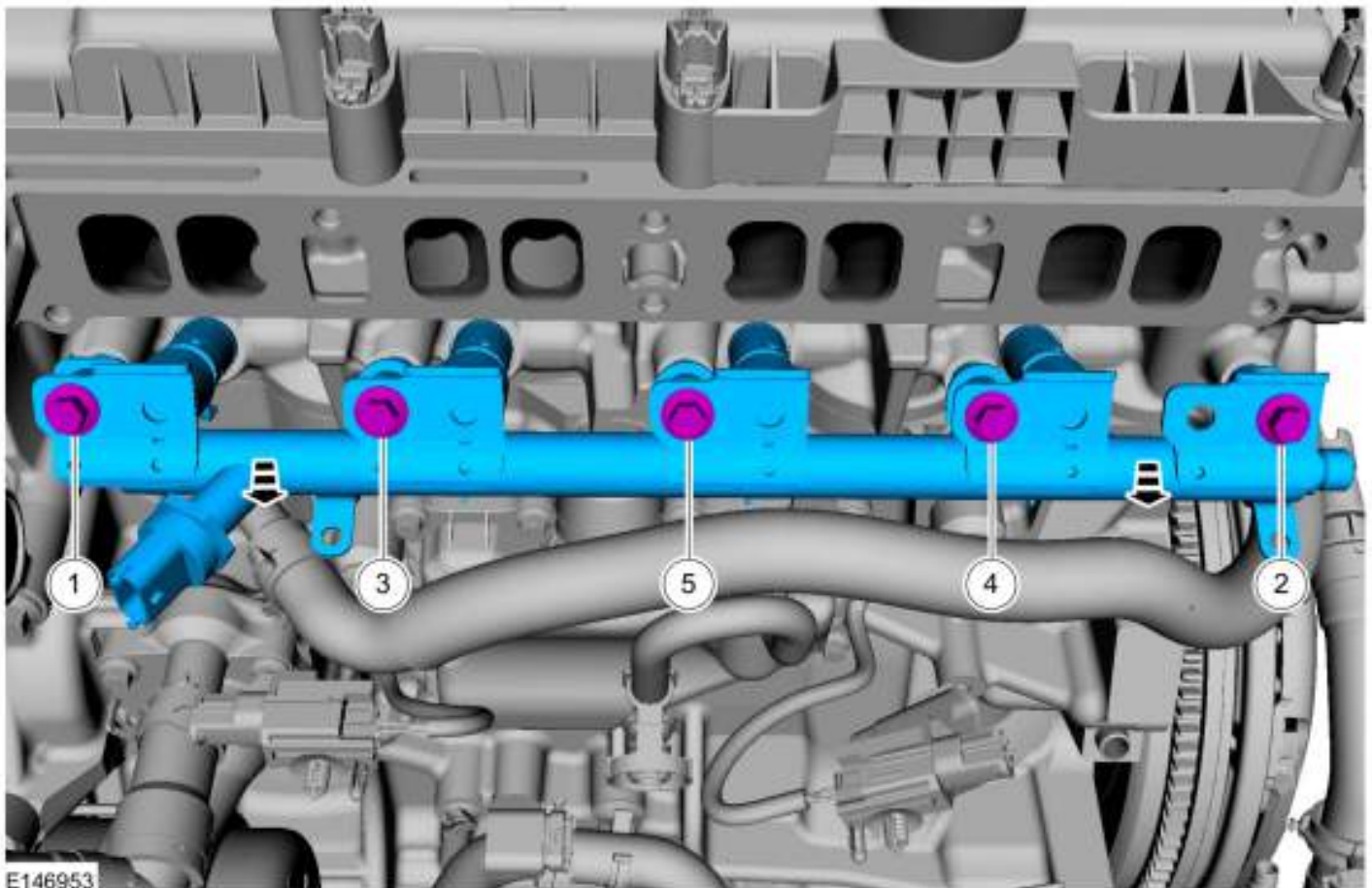

29. **NOTICE:** Take extra care when handling the components.

**NOTE:** Only use moderate force.



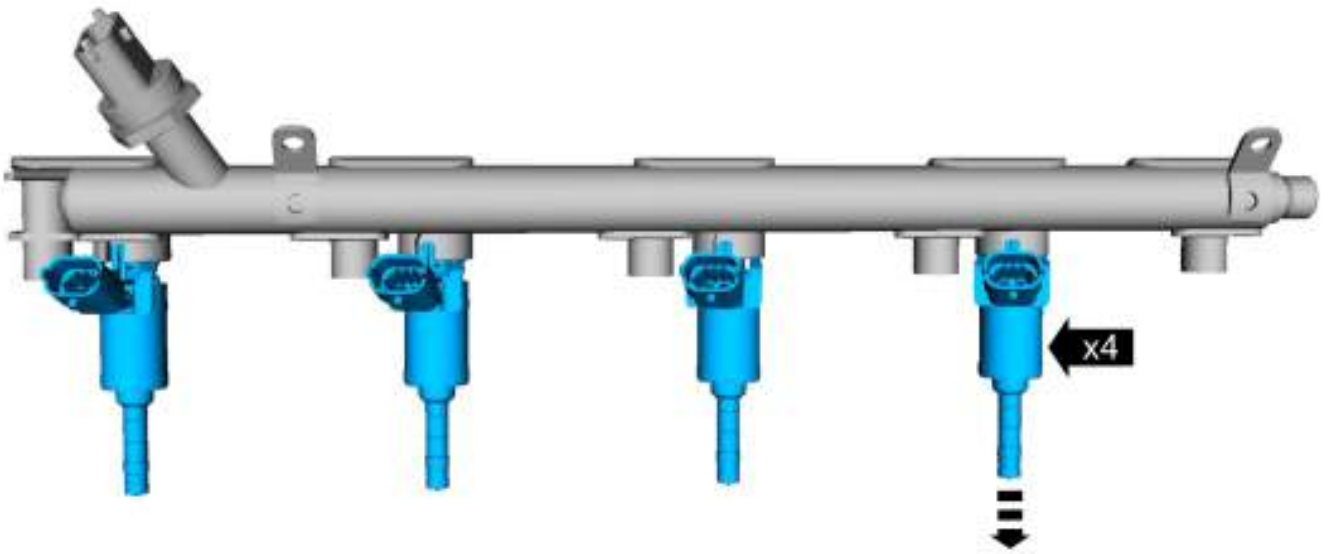

E146955



30. **NOTICE:** Take extra care when handling the components.

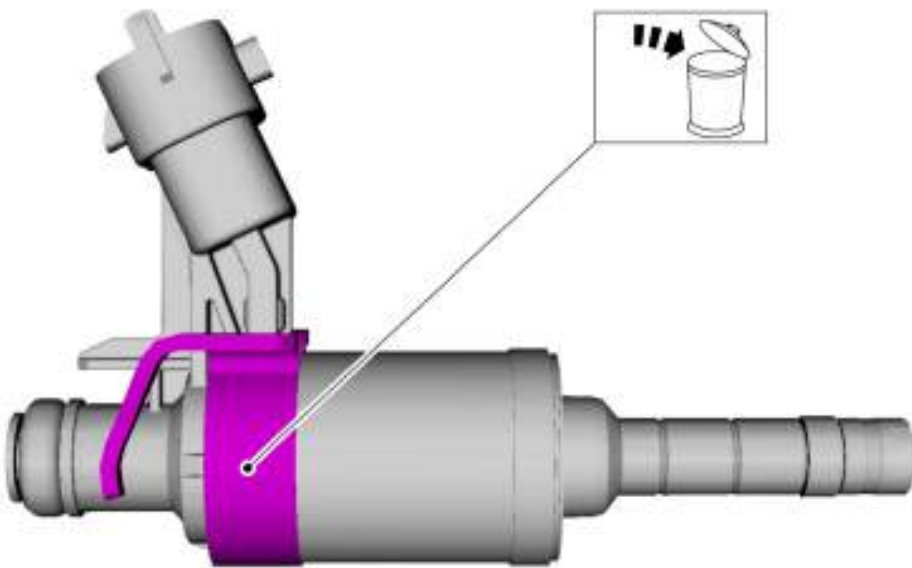

E146956



31. **NOTE:** *This step is only necessary if the component remains in the cylinder head.*

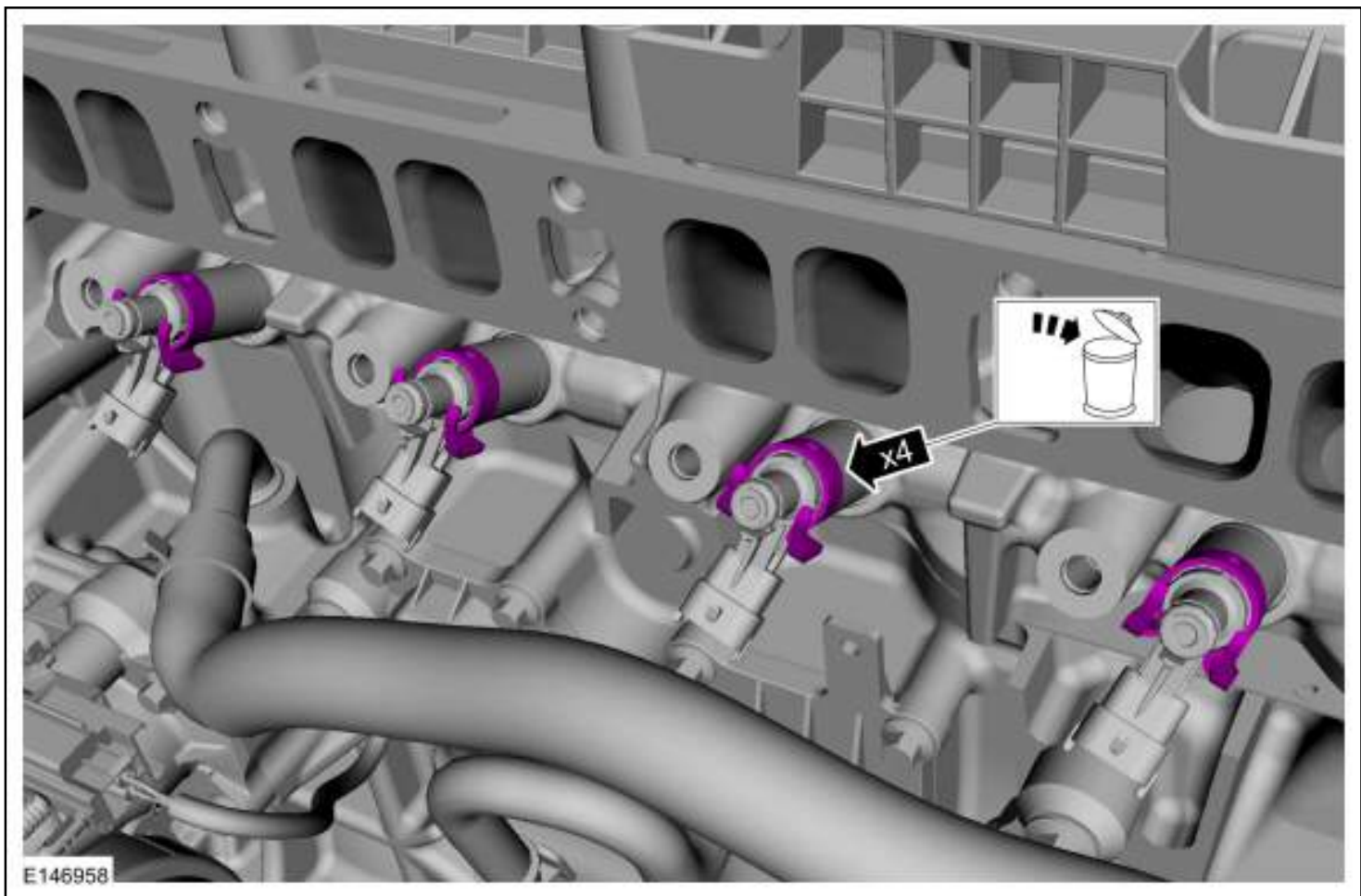

32. **NOTE:** *This step is only necessary if the component remains in the cylinder head.*

Use Special Service Tool: 205-047 Slide Hammer. , 205-047-08 Adapter for 205-047. , 310-206 Remover, Fuel Injector.

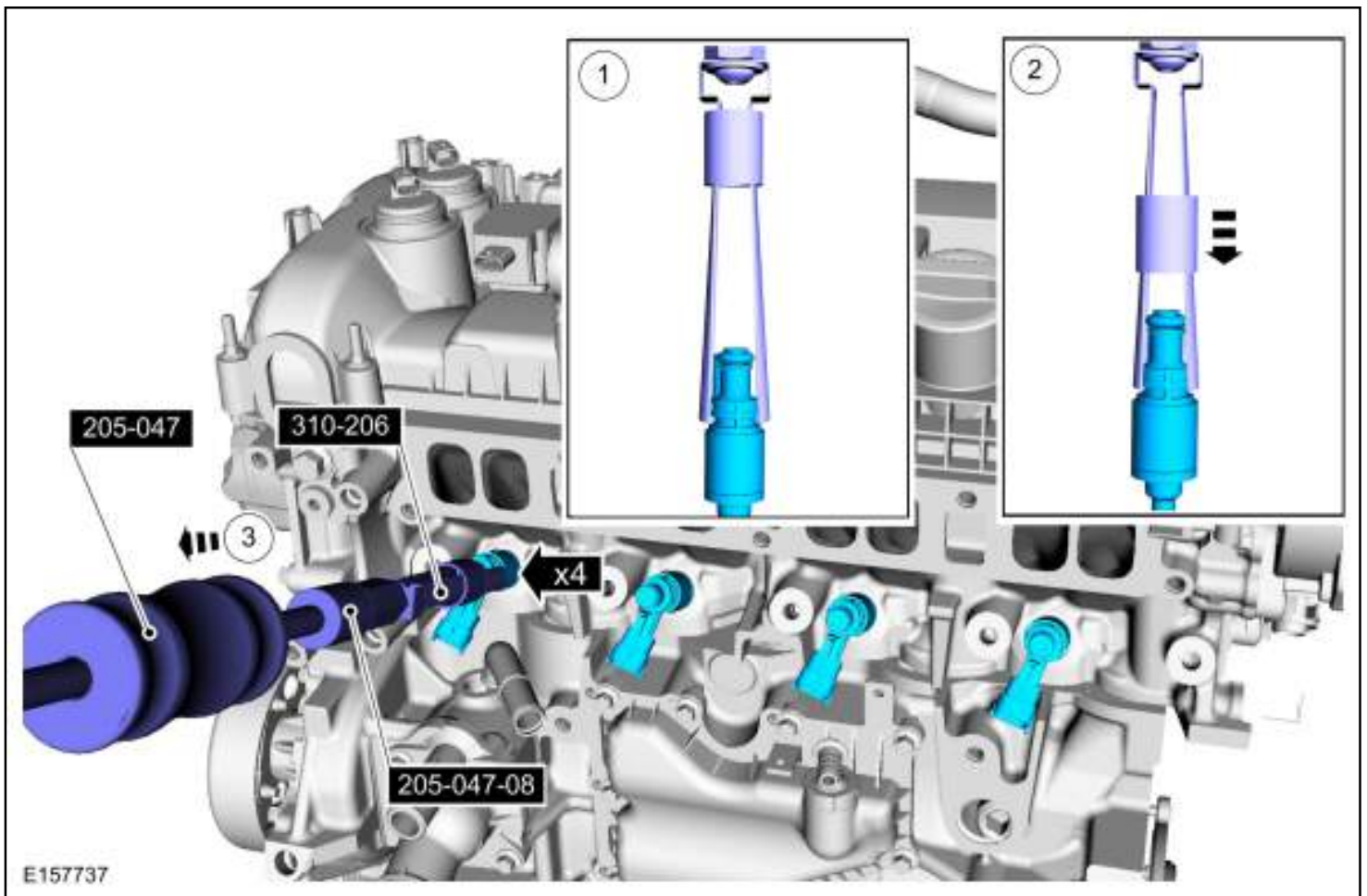

33. **NOTICE:** Take extra care when handling the components.

Use the General Equipment: Knife

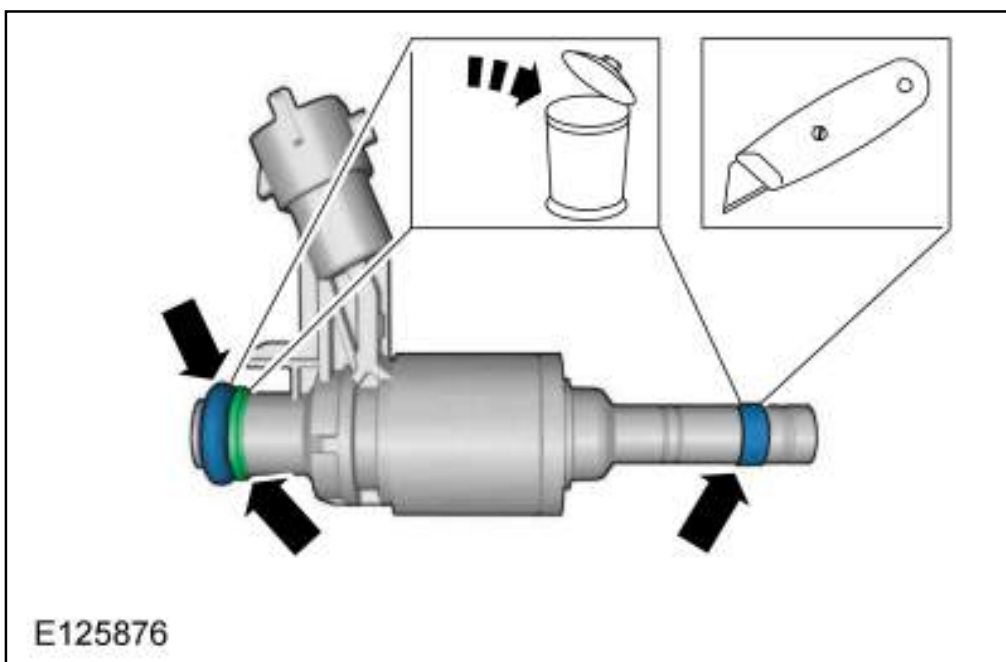

34. Refer to: Clutch Disc and Pressure Plate (308-01 Clutch - 6-Speed Manual Transmission - MMT6) .

35.

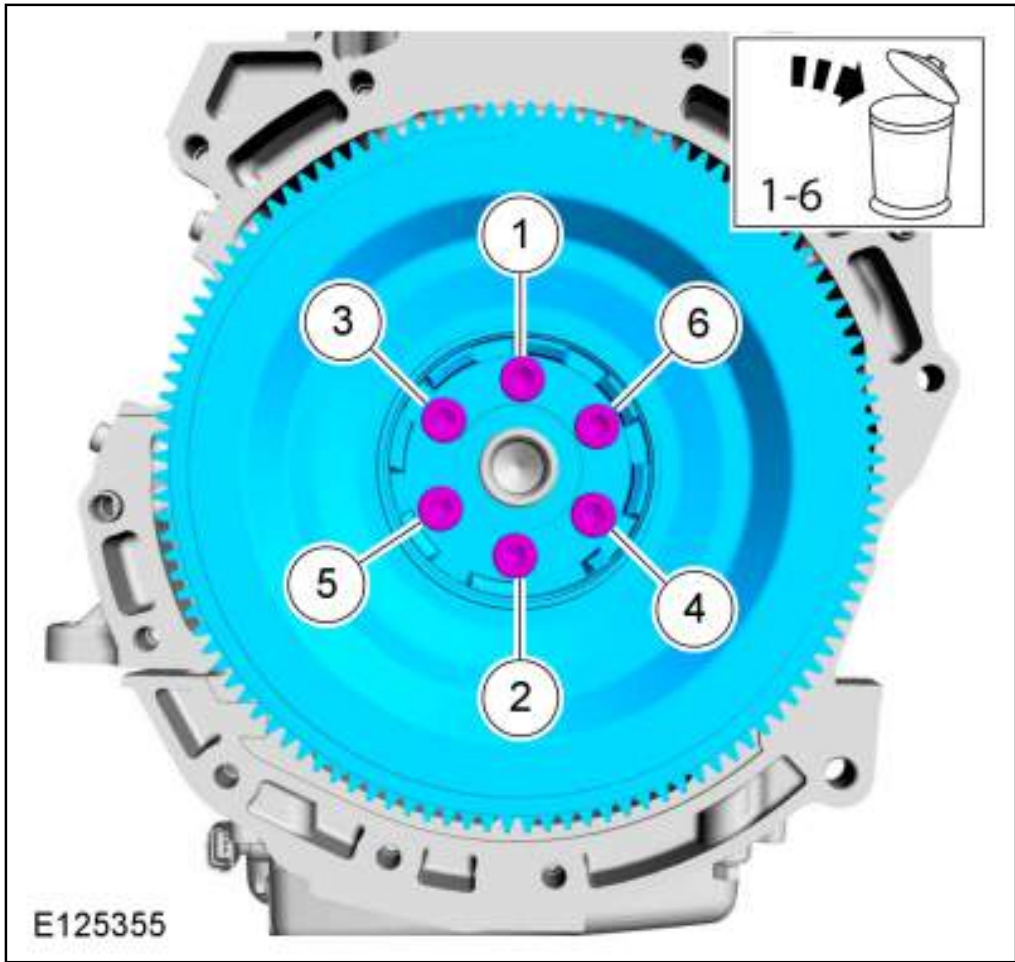

Copyright © 2019 Ford Motor Company



# Engine

Base Part Number: Base Part Number: 6L084

## Special Tool(s) / General Equipment

Lifting Bracket
Floor Crane
Pick Hook
Hose Clamp Remover/Installer
Center Punch
Mounting Table Set
Retaining Strap
Wooden Block
3.5 mm Drill Bit

1. Refer to: Fuel System Pressure Release (310-00 Fuel System - General Information - 2.0L EcoBoost (184kW/250PS) - MI4) .
2. Remove the following items:
  1. Refer to: Catalytic Converter (309-00G) .
  2. Refer to: Cooling Fan Motor and Shroud (303-03H) .
  3. Refer to: Air Conditioning (A/C) Compressor Belt (303-05H) .
3. Refer to: Cooling System Draining and Vacuum Filling (303-03H) .
- 4.

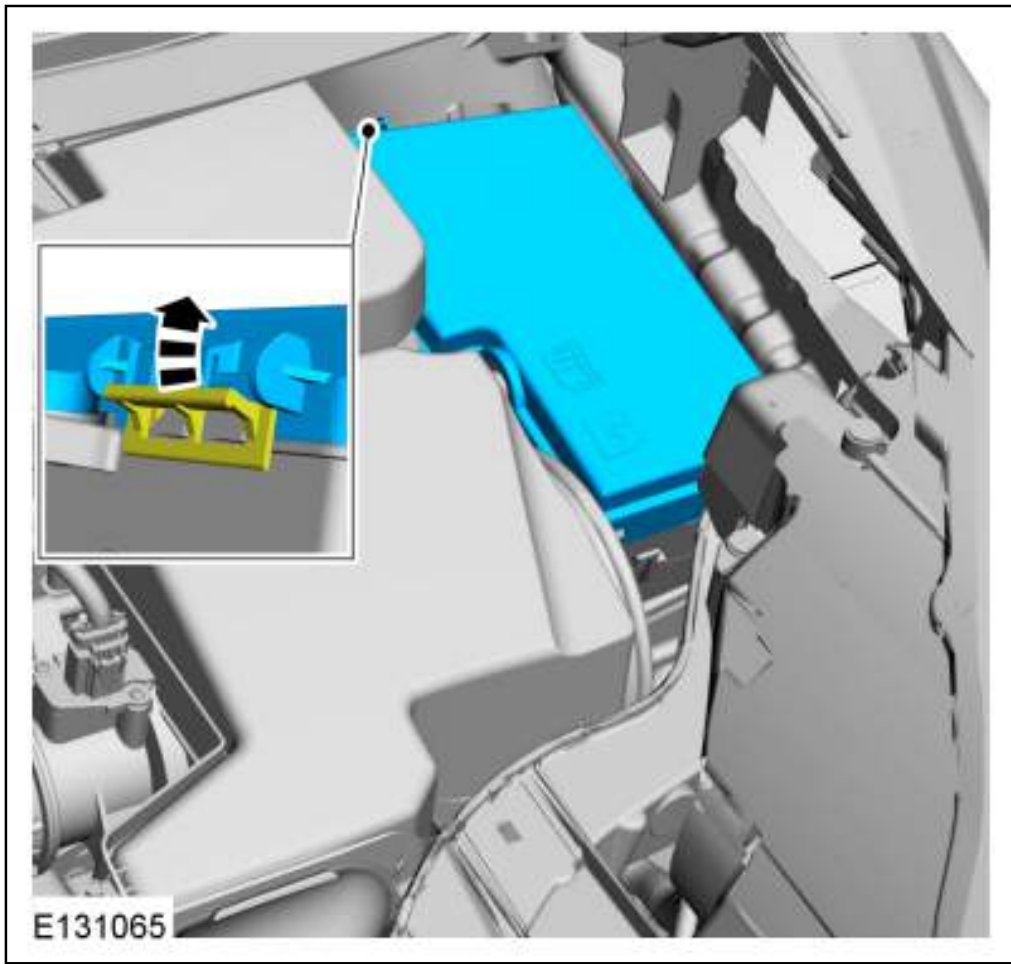

5.

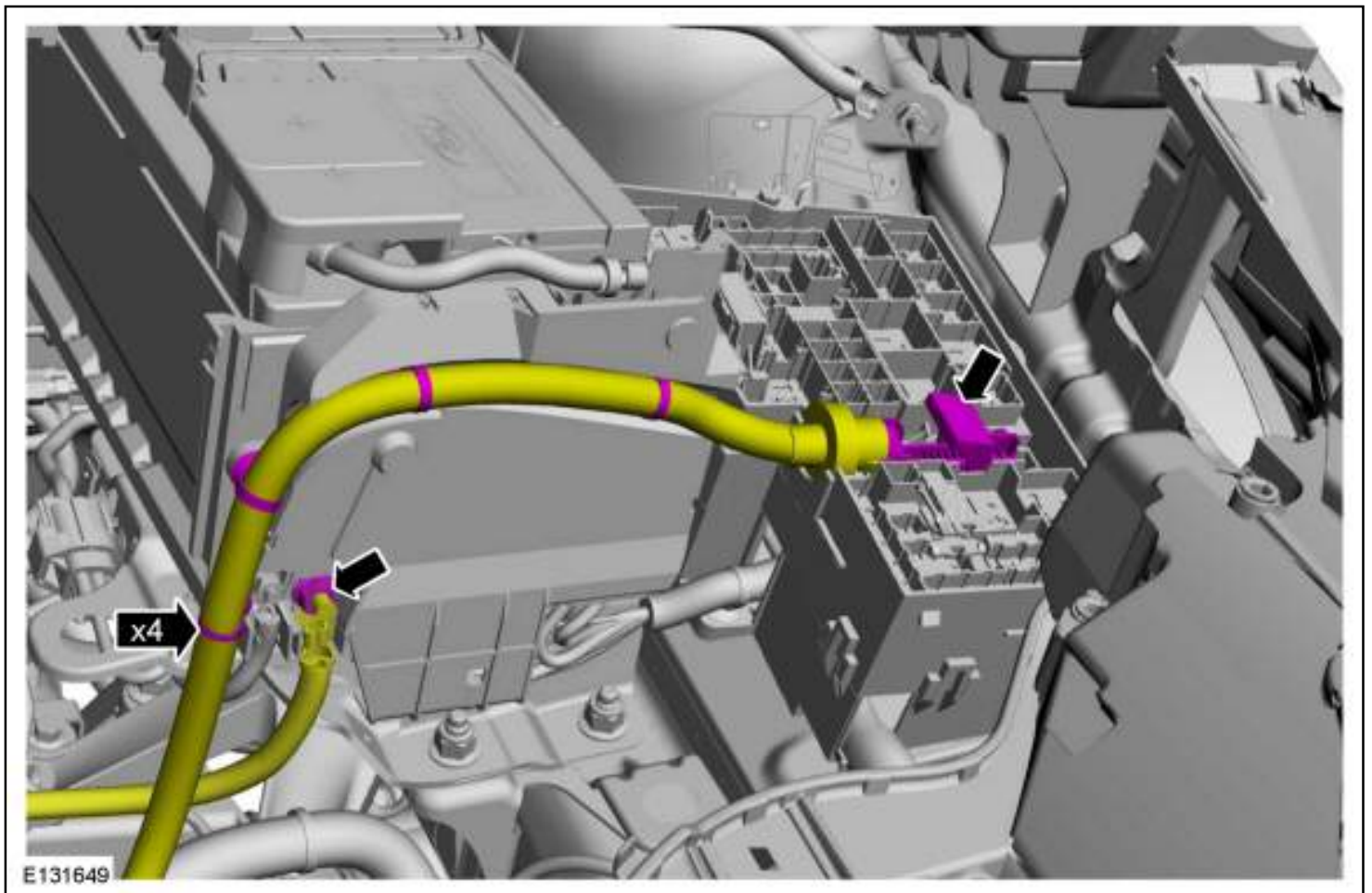

6.

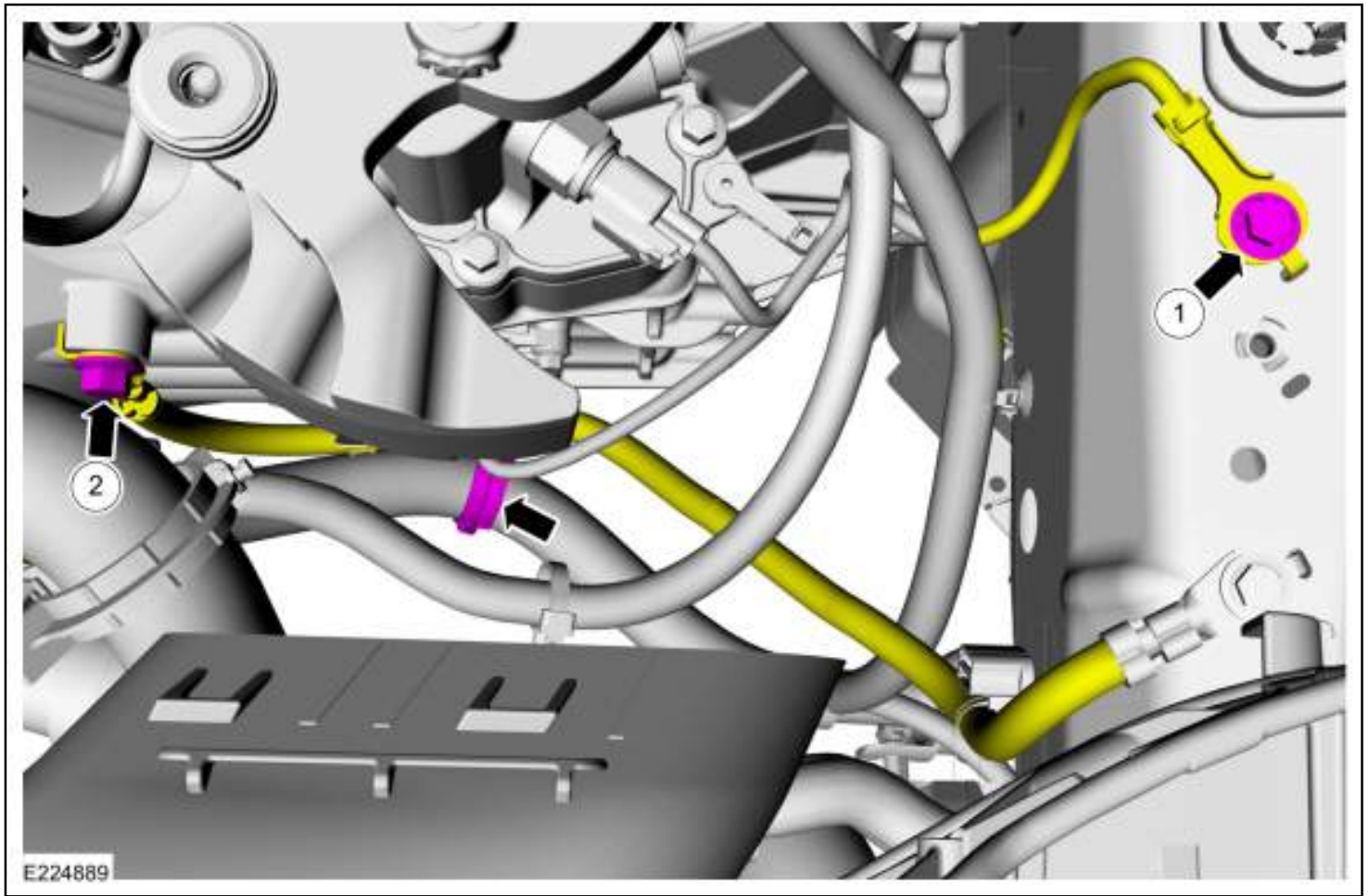

1. Use the General Equipment: Hose Clamp Remover/Installer
2. Use the General Equipment: Hose Clamp Remover/Installer
3. Refer to: Quick Release Coupling (310-00I) .

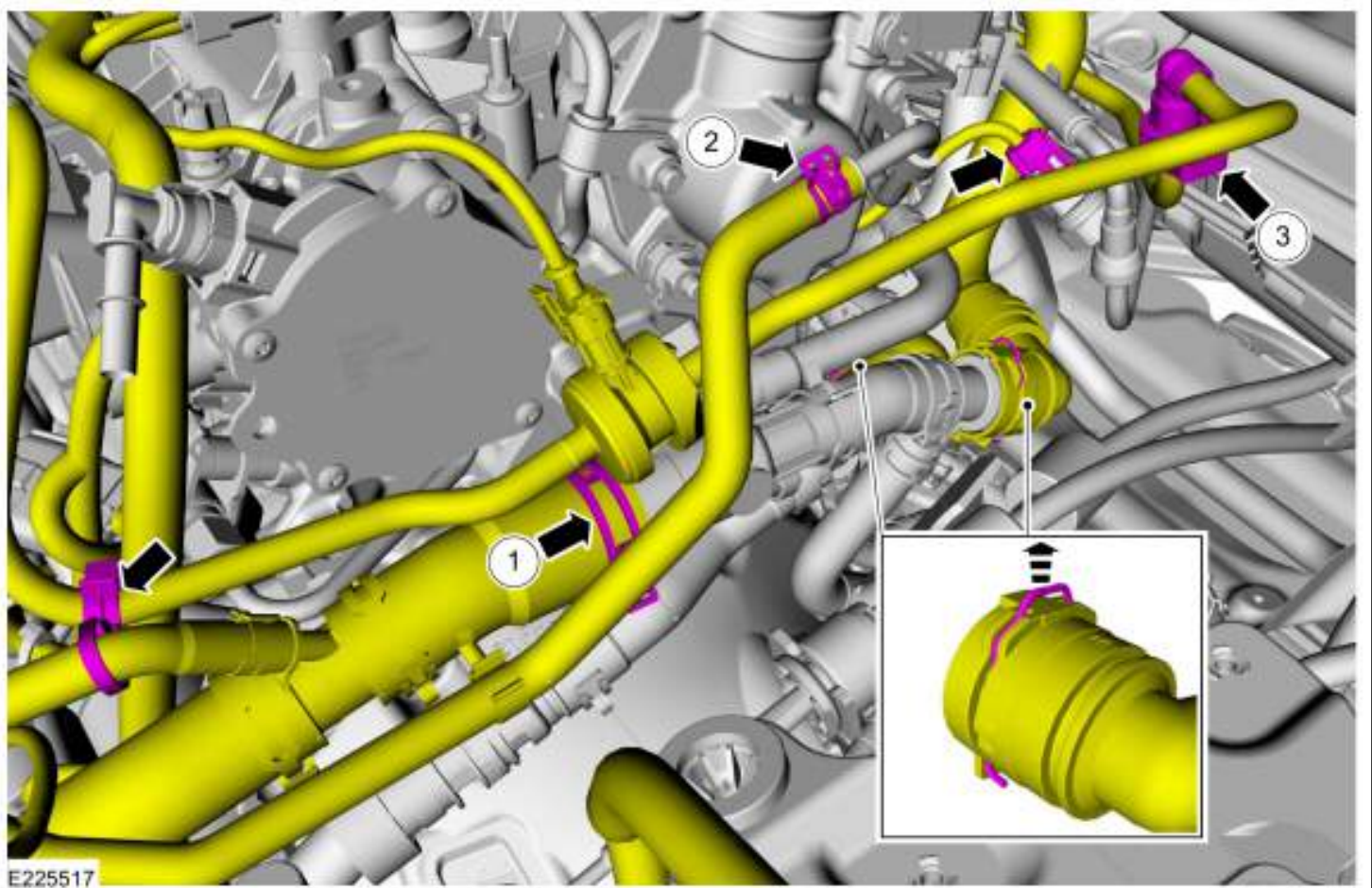

E225517



8. Use the General Equipment: Hose Clamp Remover/Installer

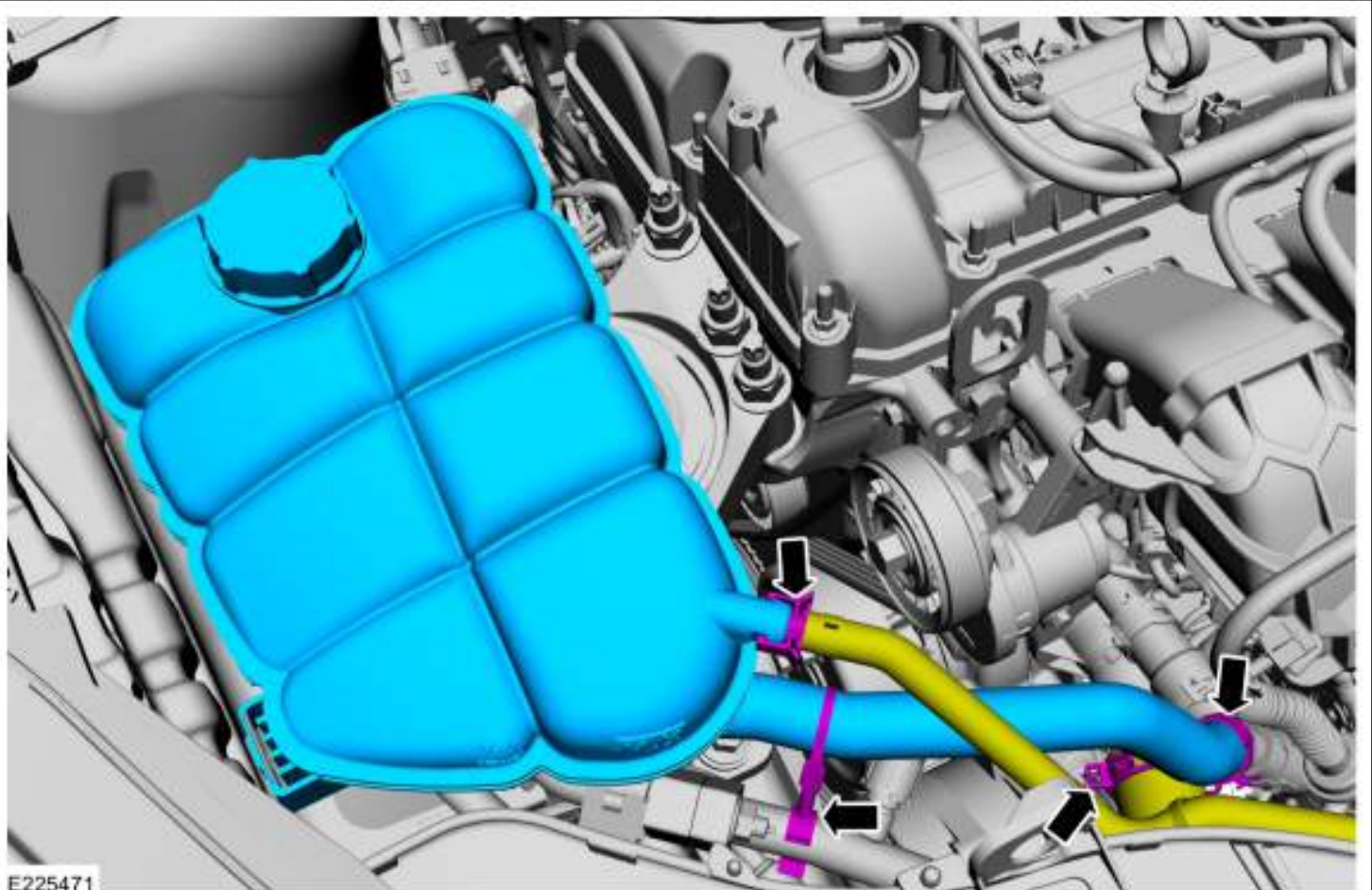

E225471



9. Refer to: Fender Splash Shield (501-02 Front End Body Panels) .

### Vehicles without PCM security shield

10.

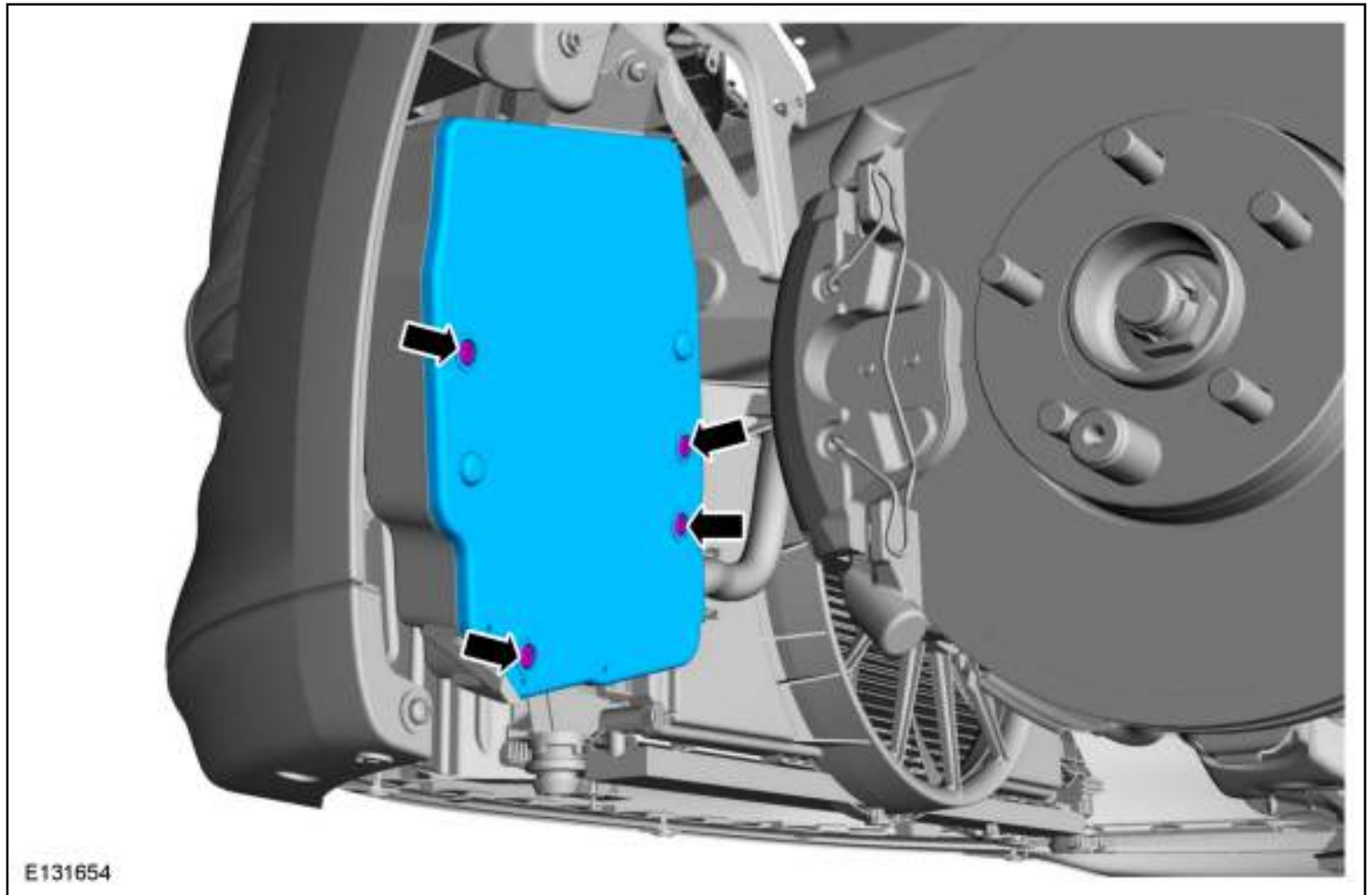

### Vehicles with PCM security shield

11. Use the General Equipment: Center Punch  
Use the General Equipment: 3.5 mm Drill Bit

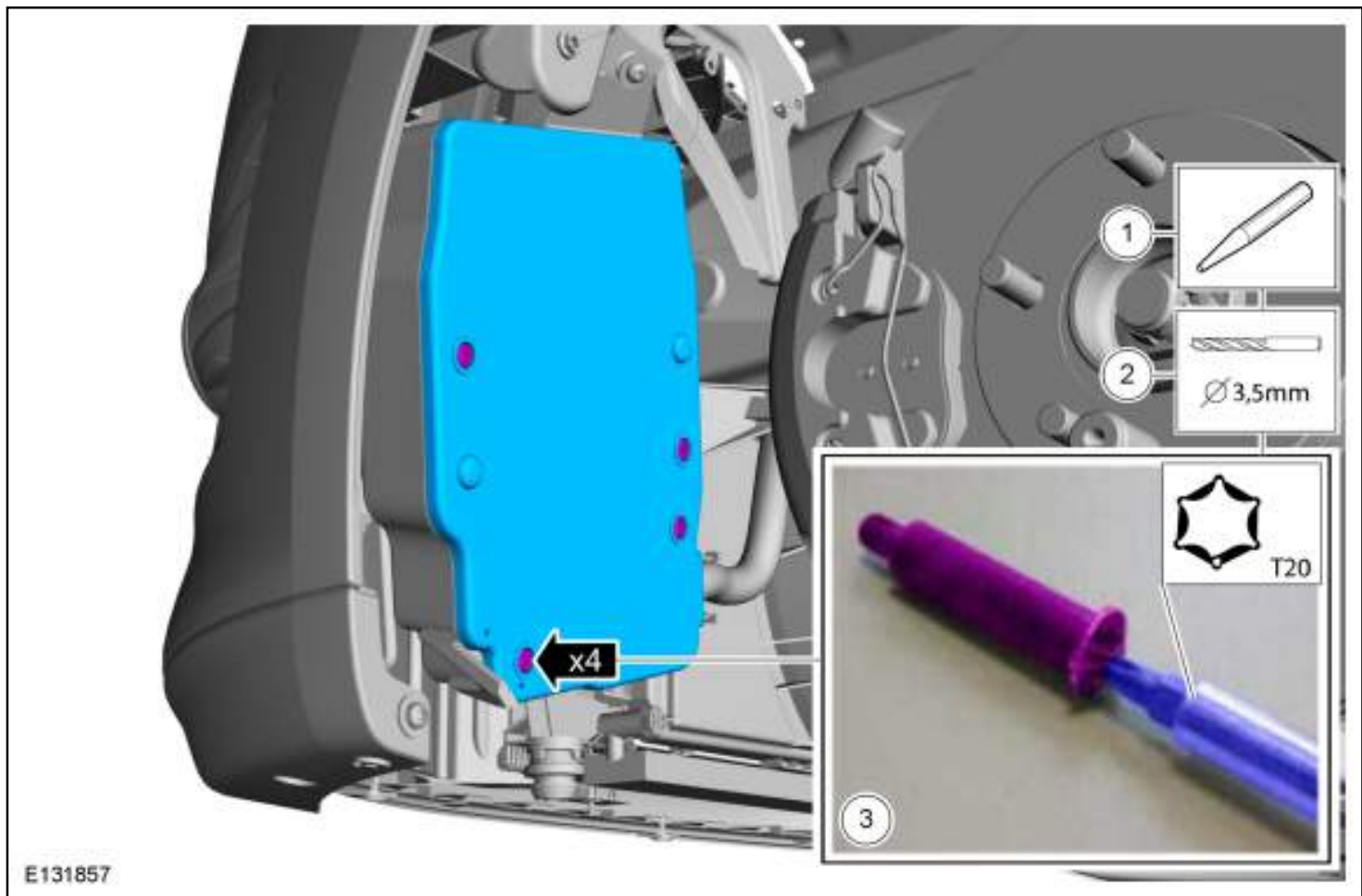

All vehicles

12.

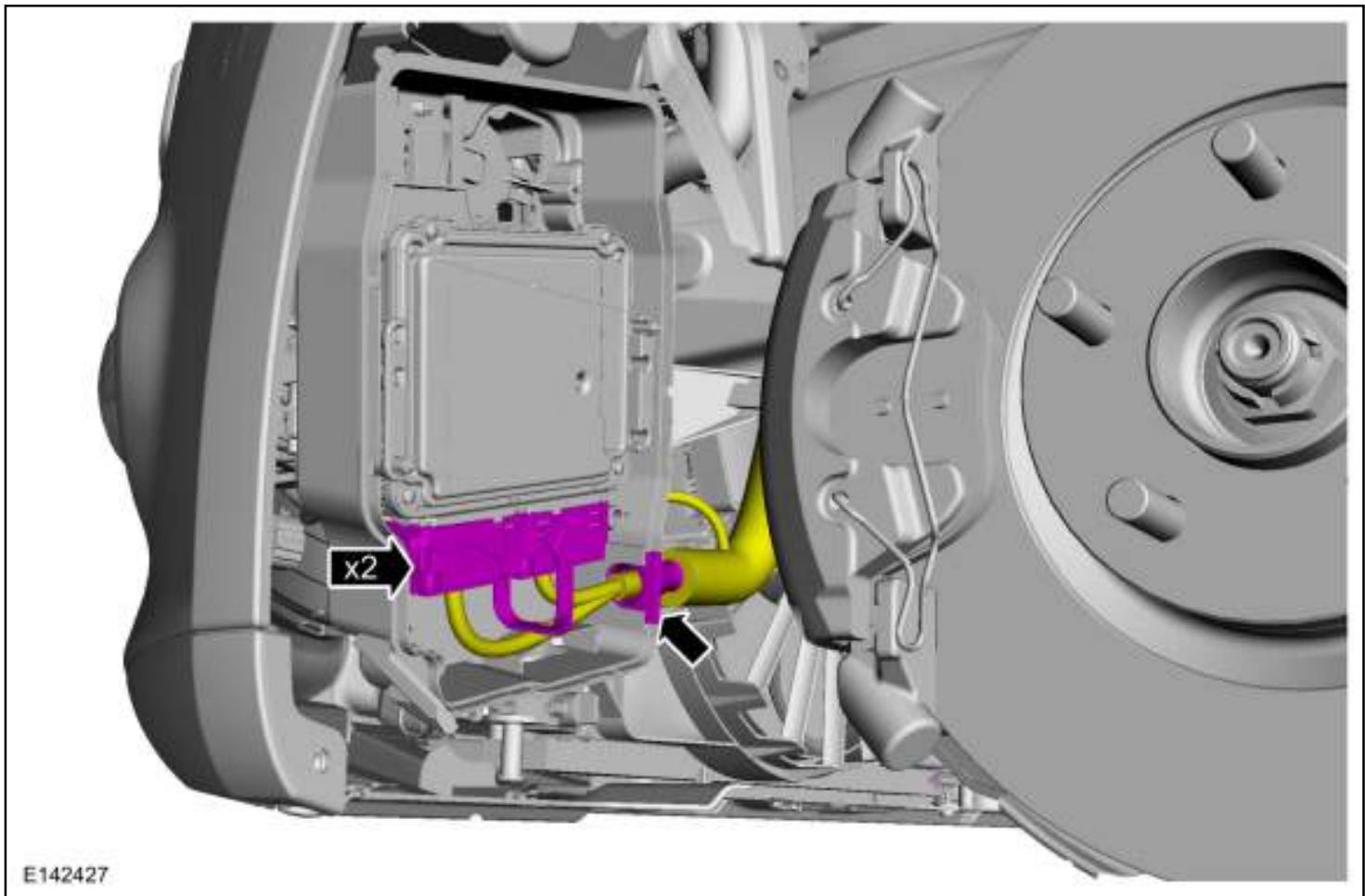

13.

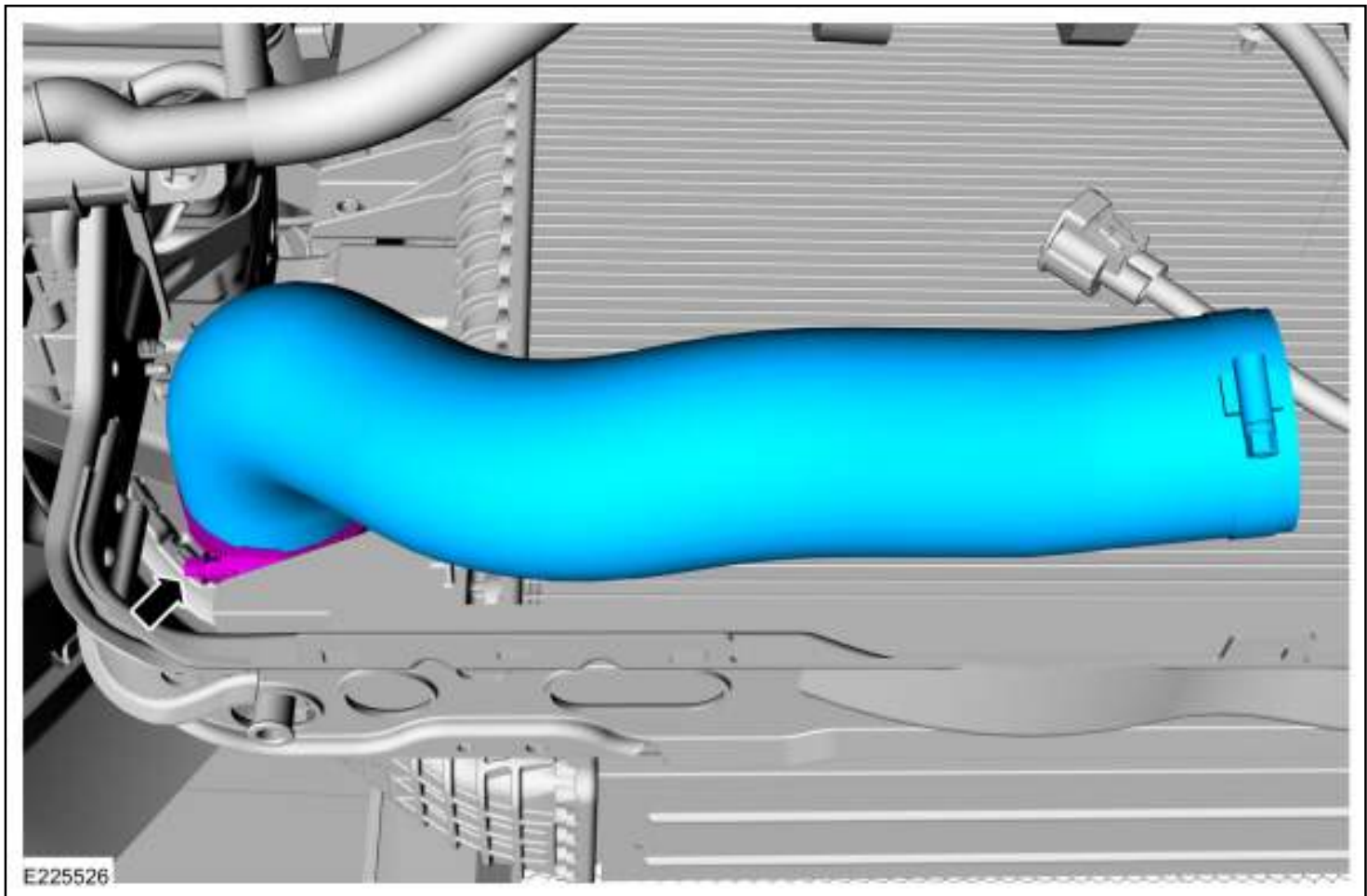

14. **NOTICE:** Make sure that no strain is placed on the fuel lines and wiring harnesses.

Use the General Equipment: Pick Hook

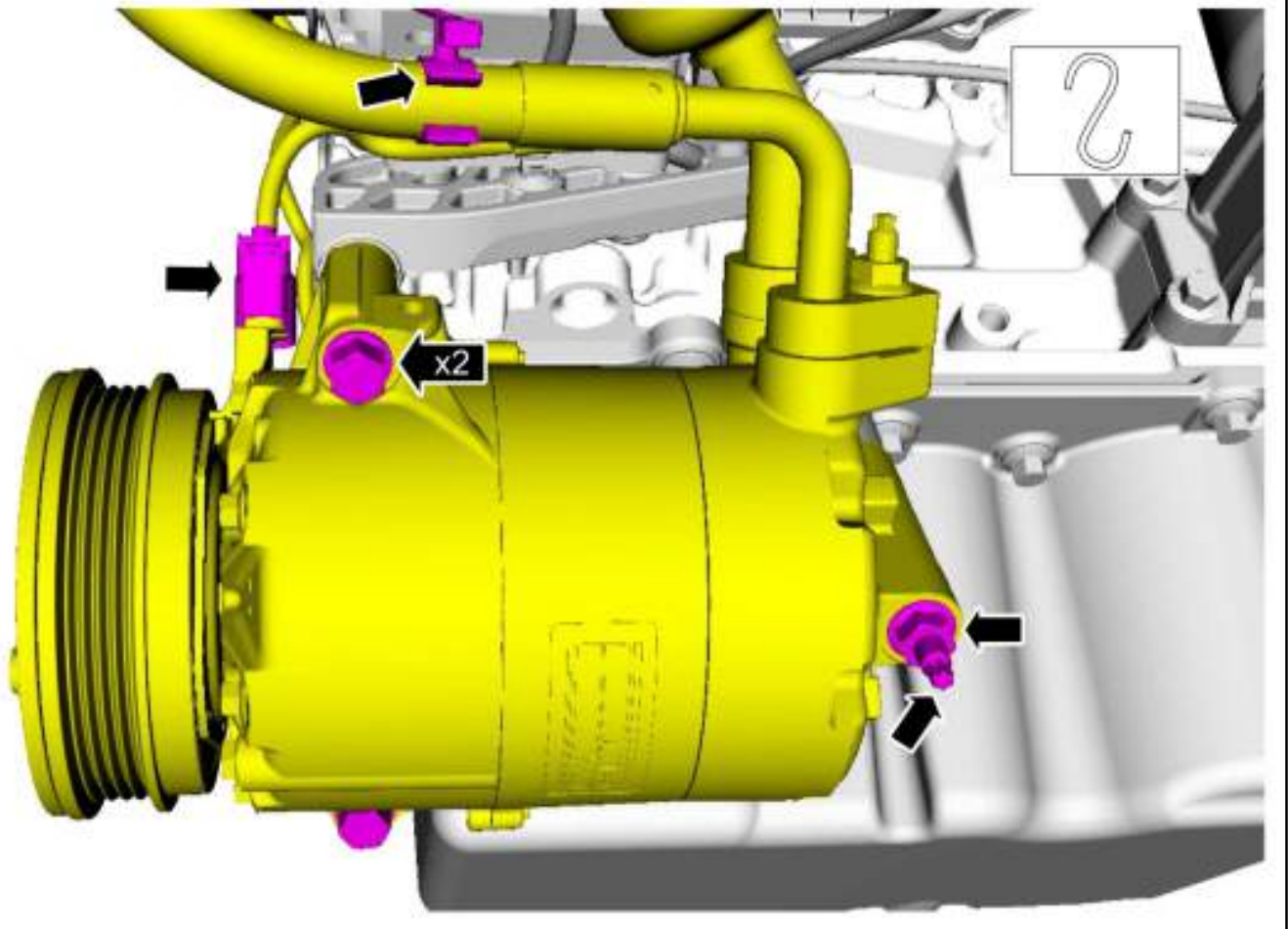

E164277

15.

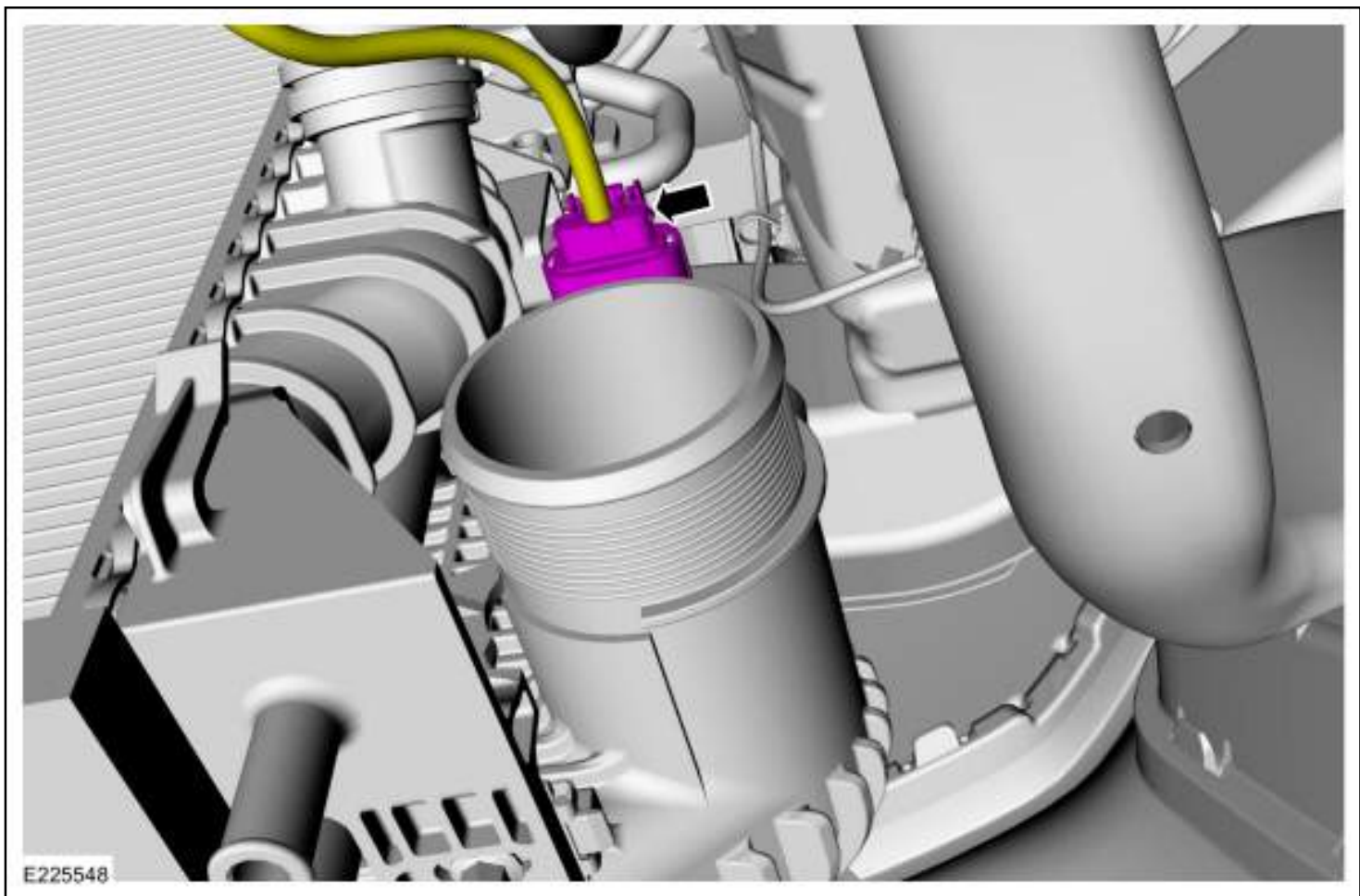

Refer to: Front Halfshaft LH - Detach from the transmission - 5-Speed Manual Transmission - B5/IB5/5-Speed Manual Transmission - MTX75/6-Speed Manual Transmission - B6/6-Speed Manual Transmission - MMT6/6-Speed PowerShift Transmission - DPS6/6DCT250 ( ) .

16. **NOTICE: Gearshift cables must not be kinked or bent.**

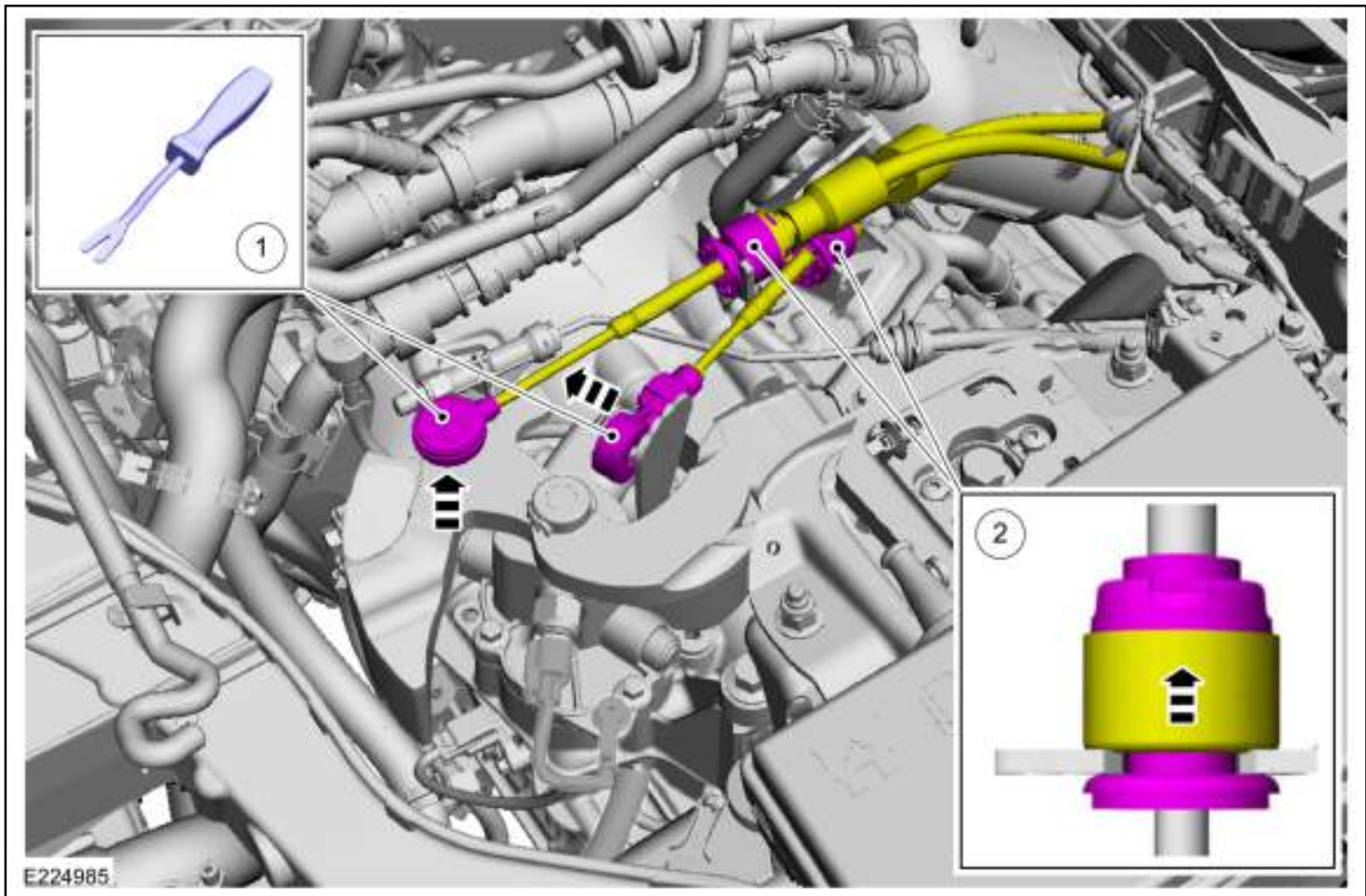

E224985

17. **NOTICE:** Make sure that all openings are sealed.

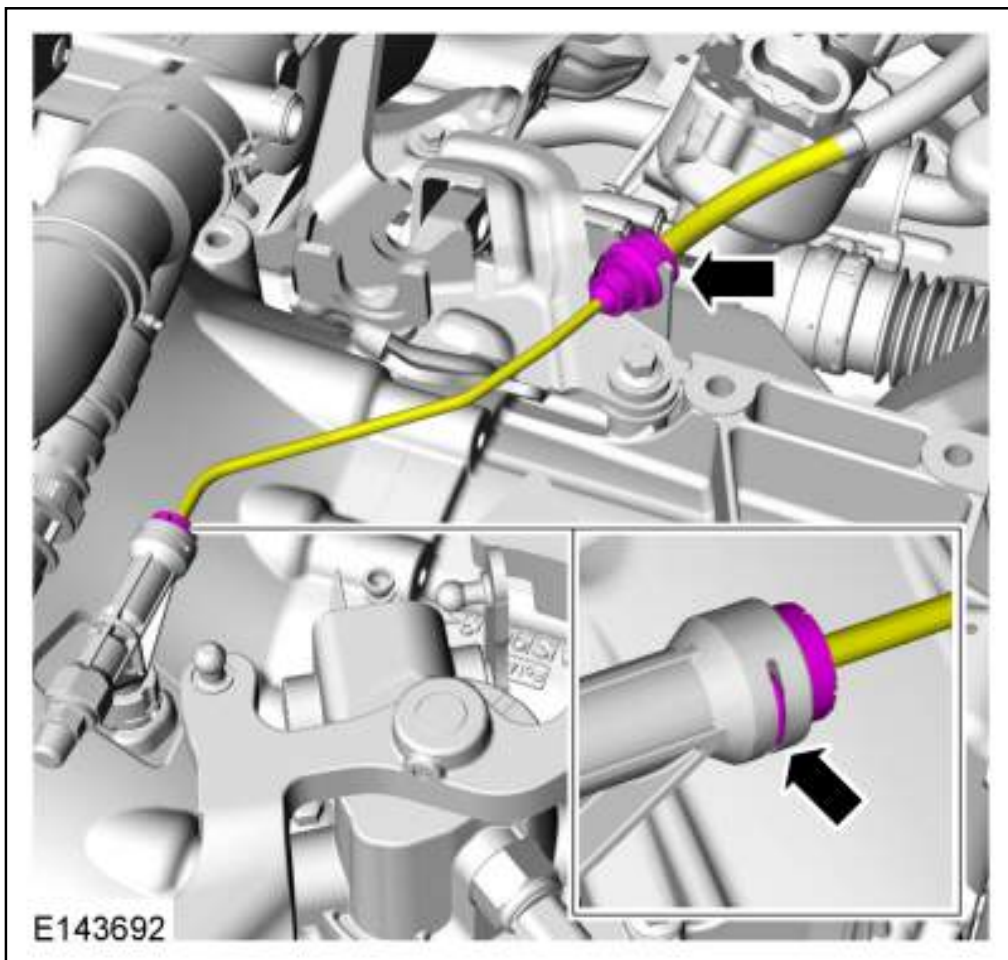

E143692

18.



**⚠️ WARNING:** Fuel may remain pressurized in some fuel lines after the Fuel System Pressure Release procedure. Wear safety gloves and a face shield when disconnecting pressure lines to avoid skin and eye contact. Failure to follow this instruction may result in serious personal injury.

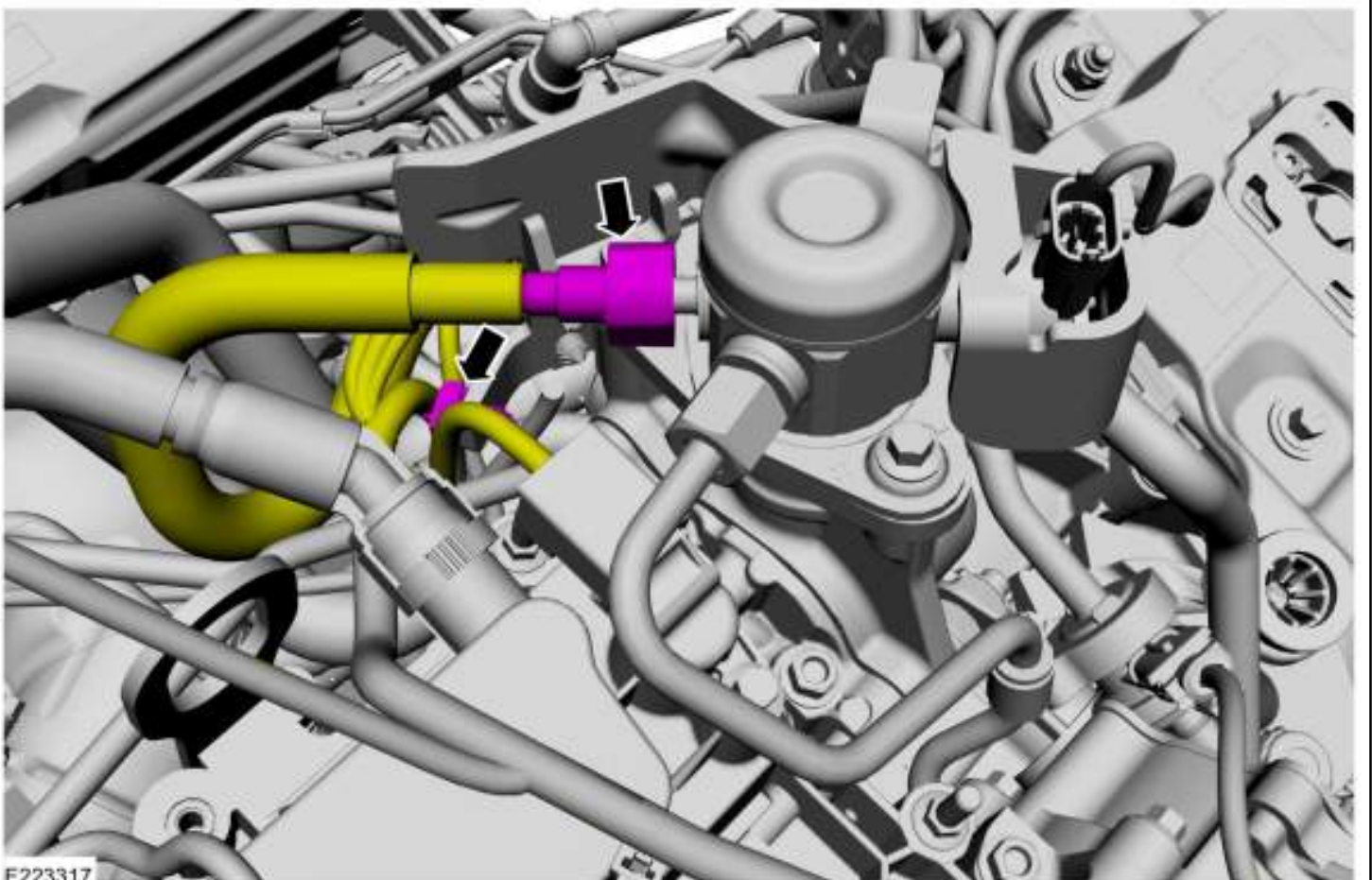

E223317

cardiagn.com



19. **⚠️ WARNING:** Always secure engines, transmissions, or other heavy components to the

**support fixture with straps and wooden support blocks. Improperly secured assemblies could fall off the fixture, resulting in serious personal injury.**

Install the following items:

- Use the General Equipment: Mounting Table Set
- Use the General Equipment: Wooden Block
- Use the General Equipment: Retaining Strap



20.

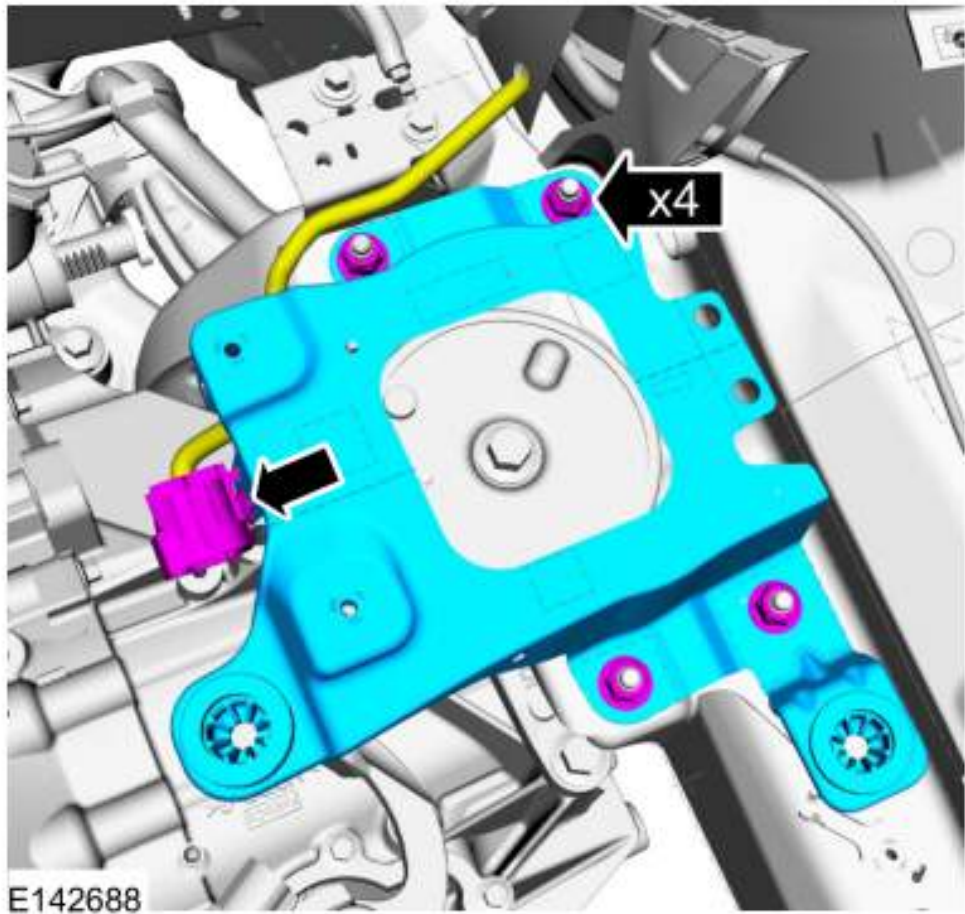

21.

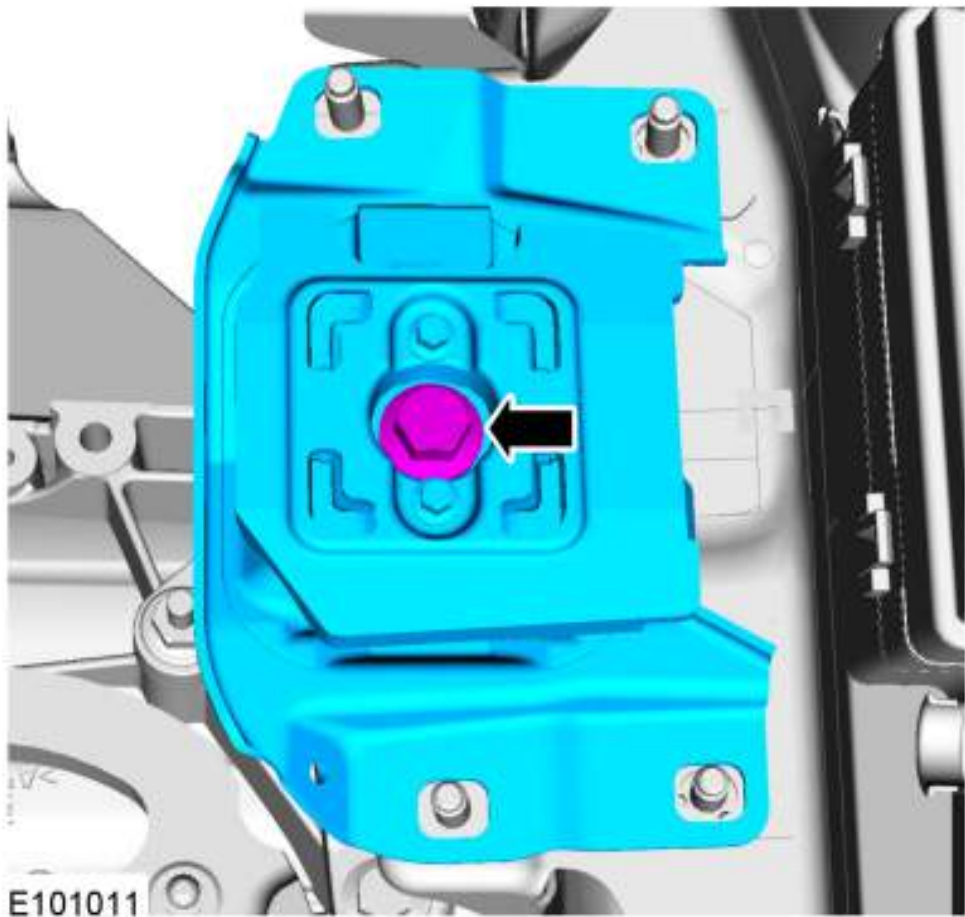

22.

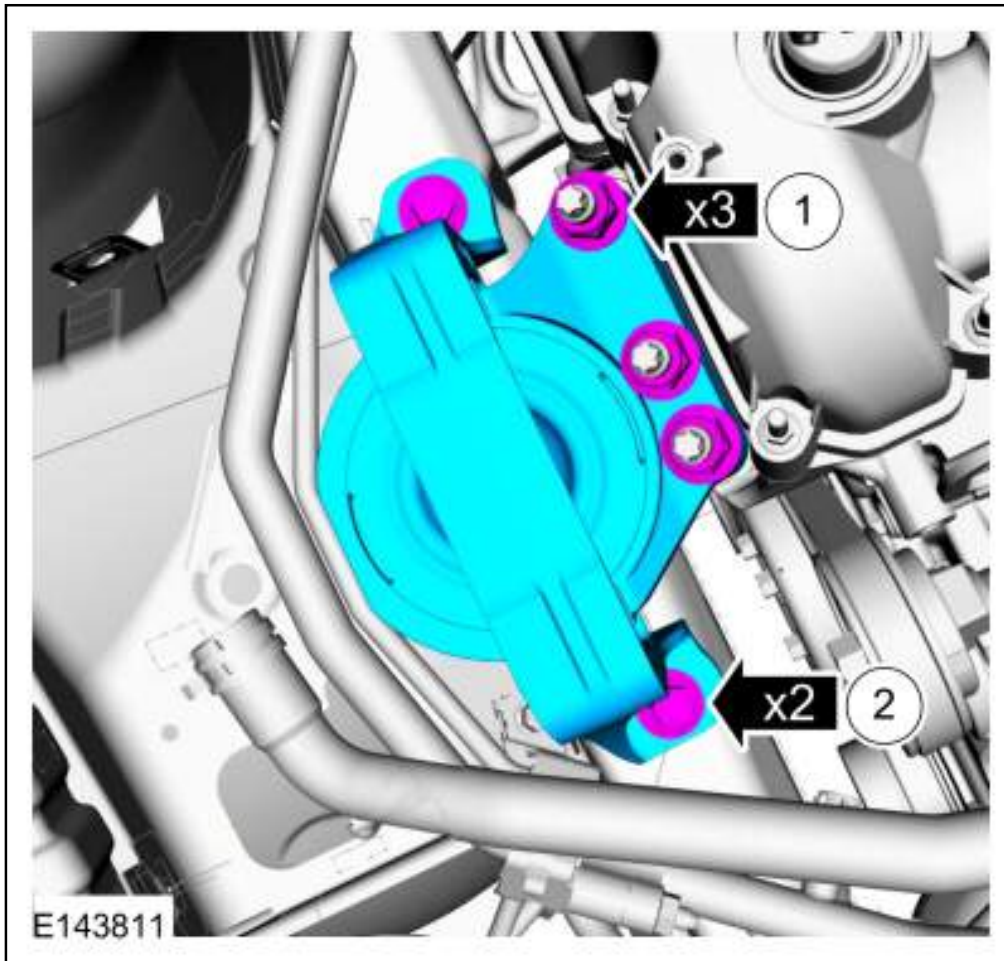

23. **NOTICE:** Make sure that no components catch.

**NOTE:** This step requires the aid of another technician.

Refer to: Jacking and Lifting (100-02 Jacking and Lifting) .

24. Install the following items:

1. Use the General Equipment: Lifting Bracket  
Use the General Equipment: Floor Crane

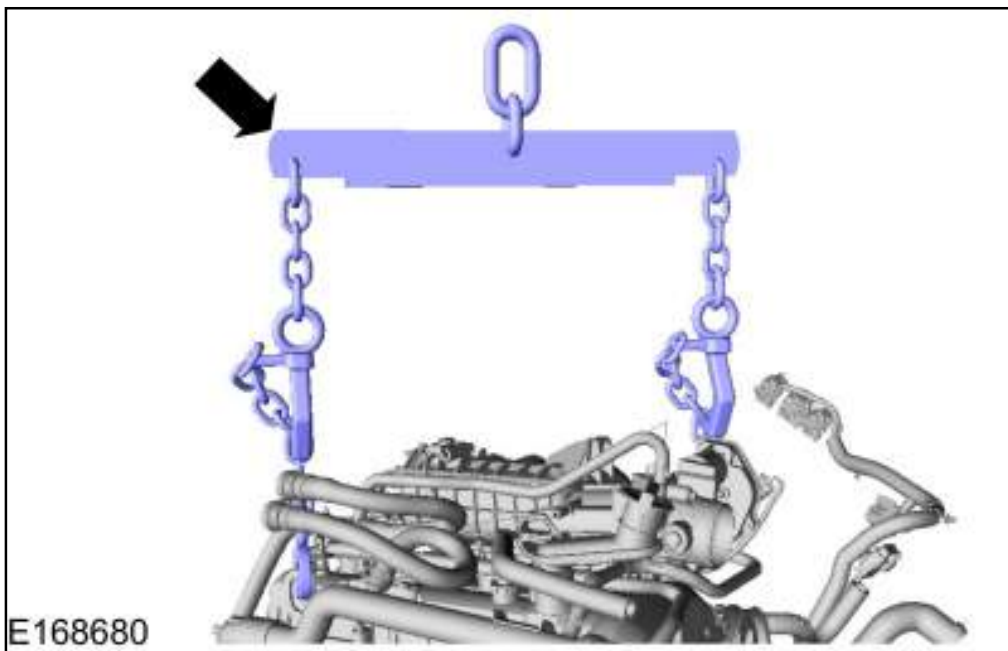

25. Remove the following items:

- Use the General Equipment: Mounting Table Set
- Use the General Equipment: Wooden Block
- Use the General Equipment: Retaining Strap



26.

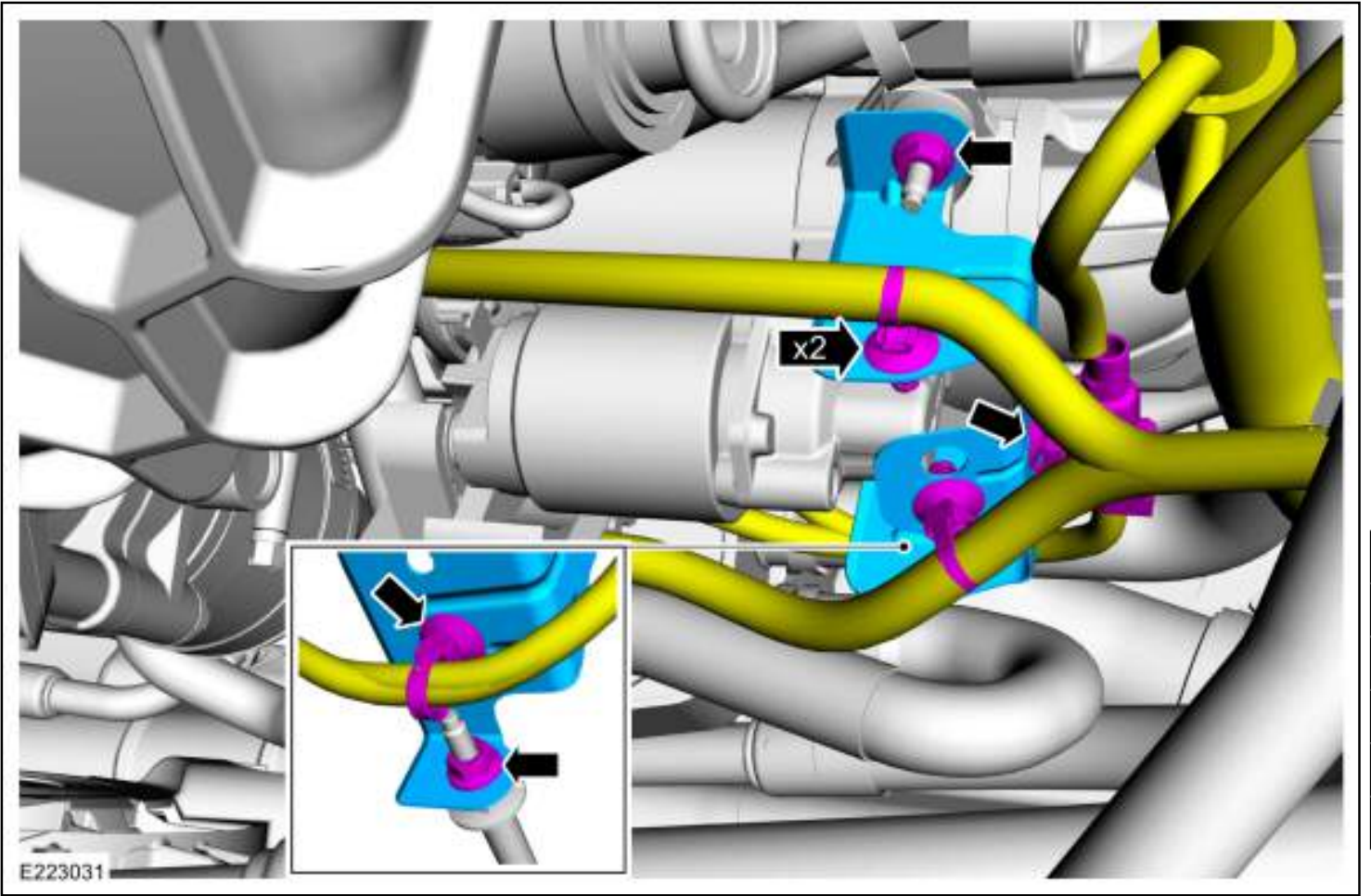

27.

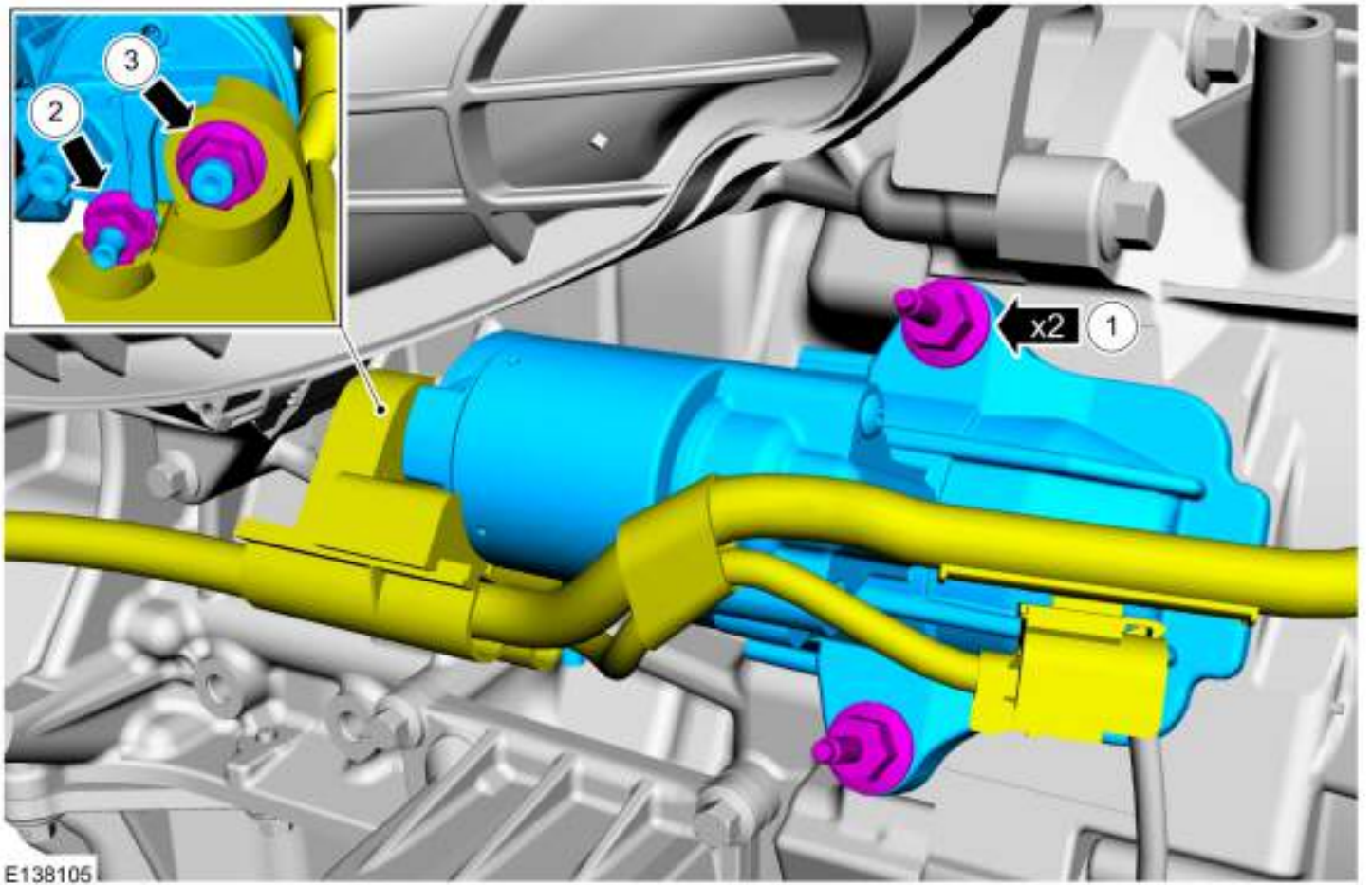

E138105



care

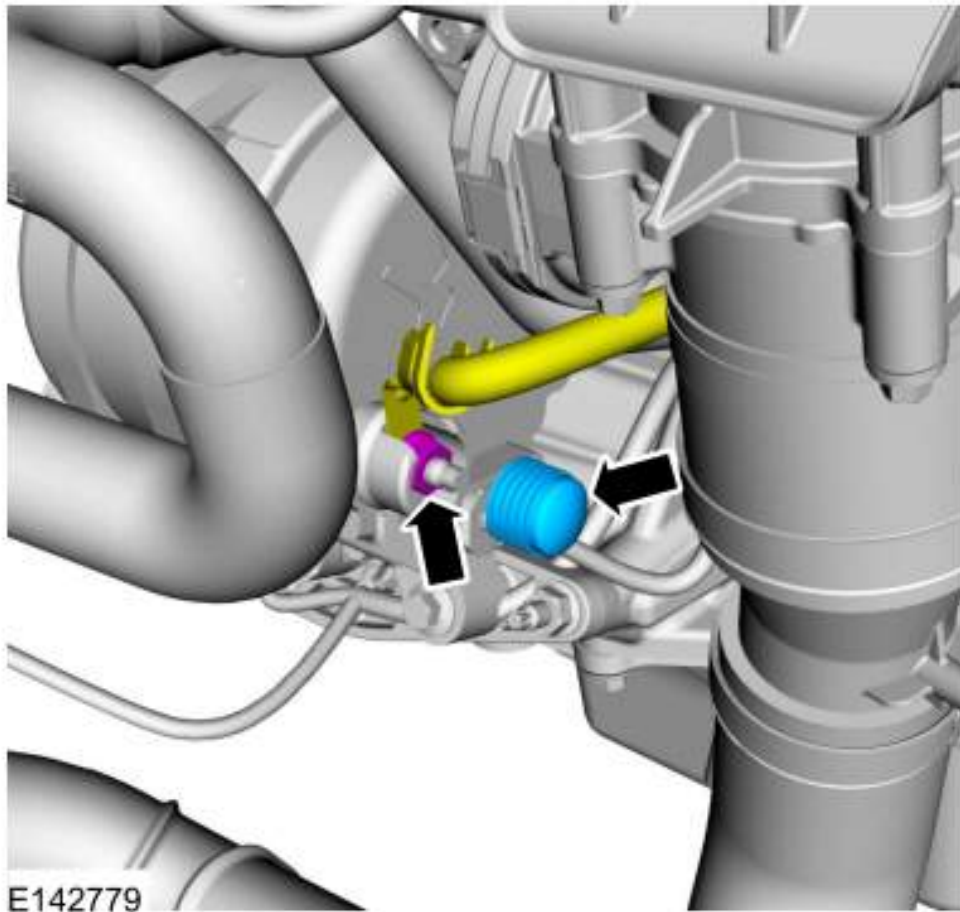

E142779



29.



E136524



30.

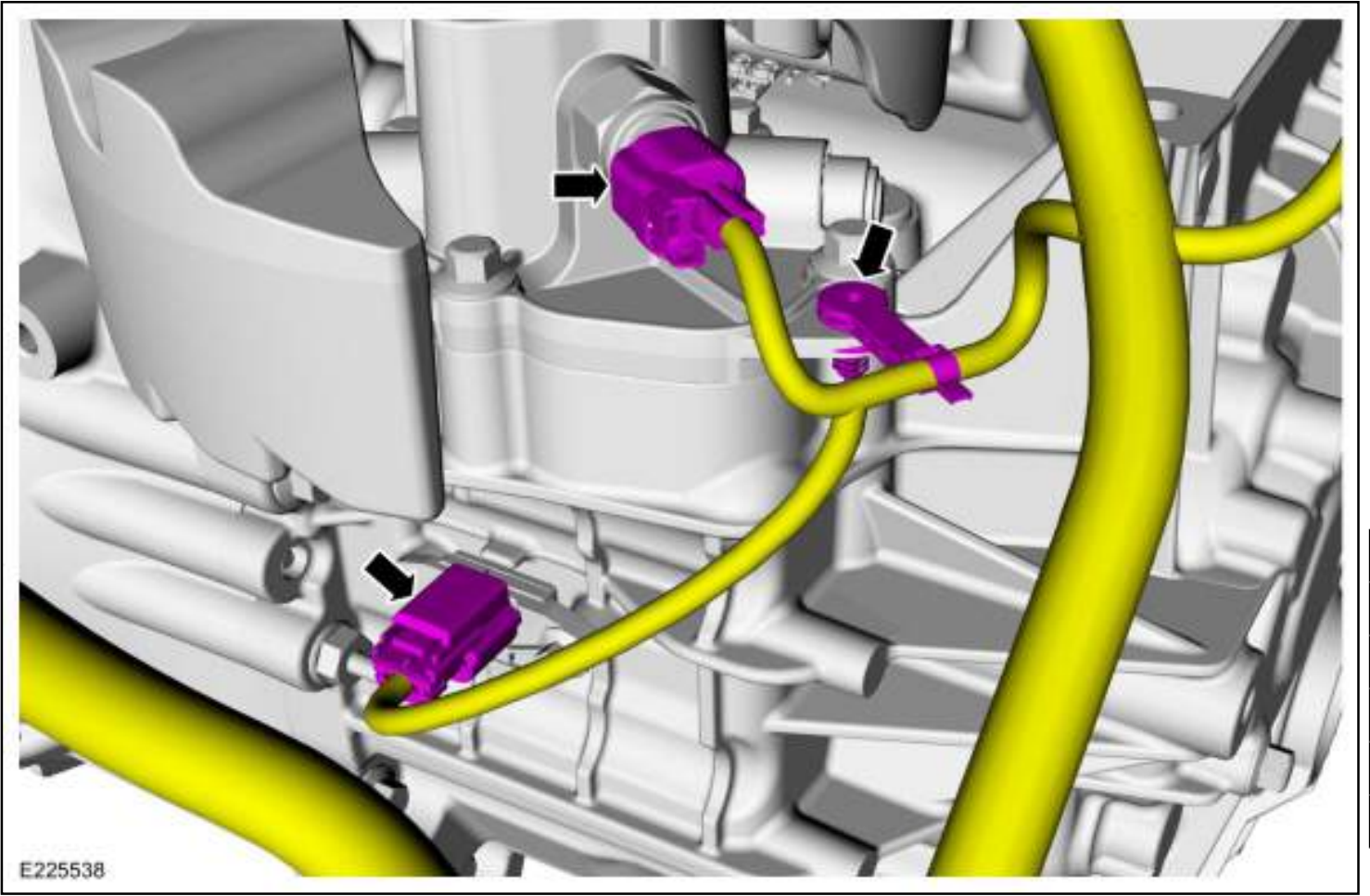

31.

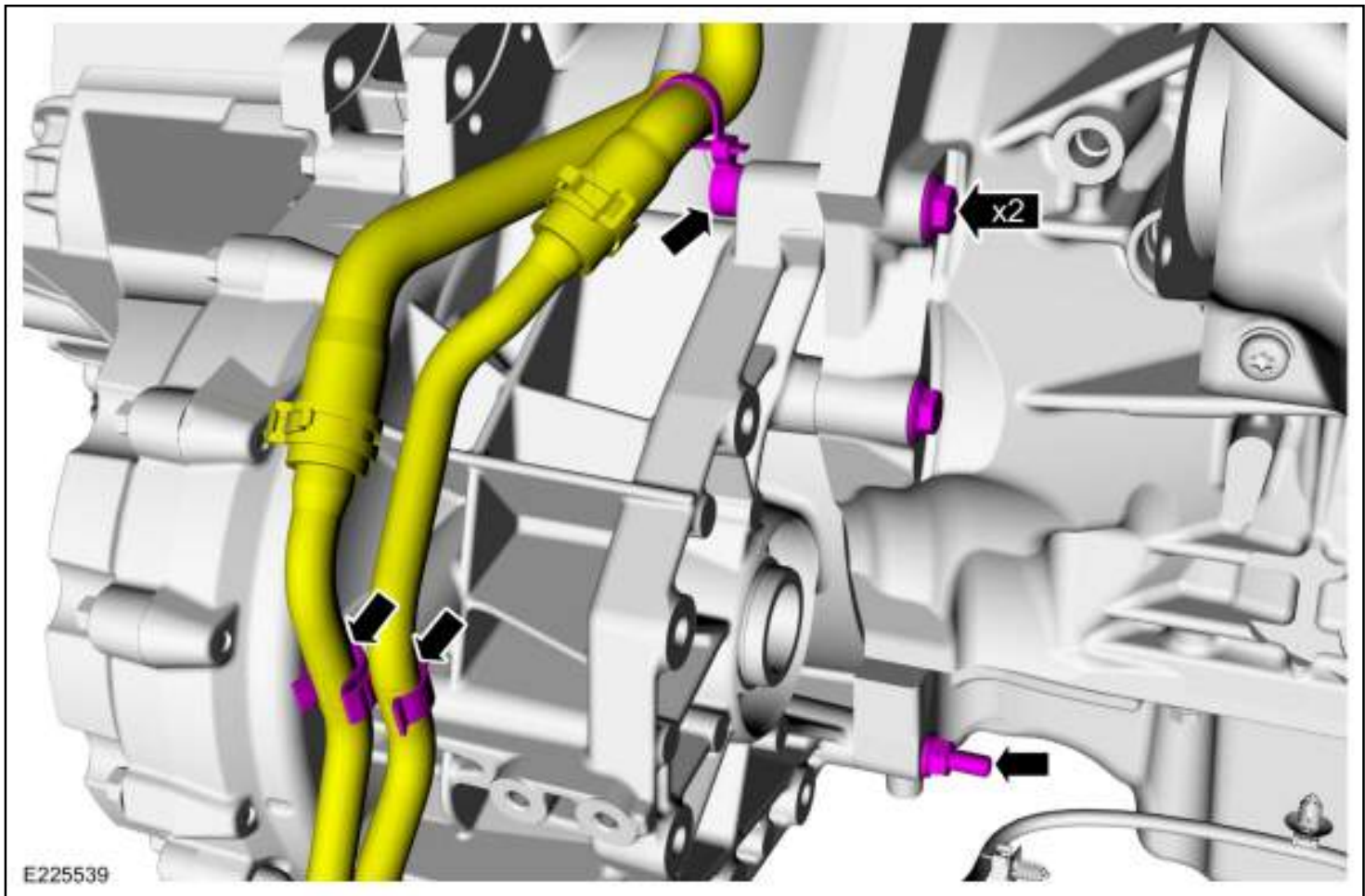

32.

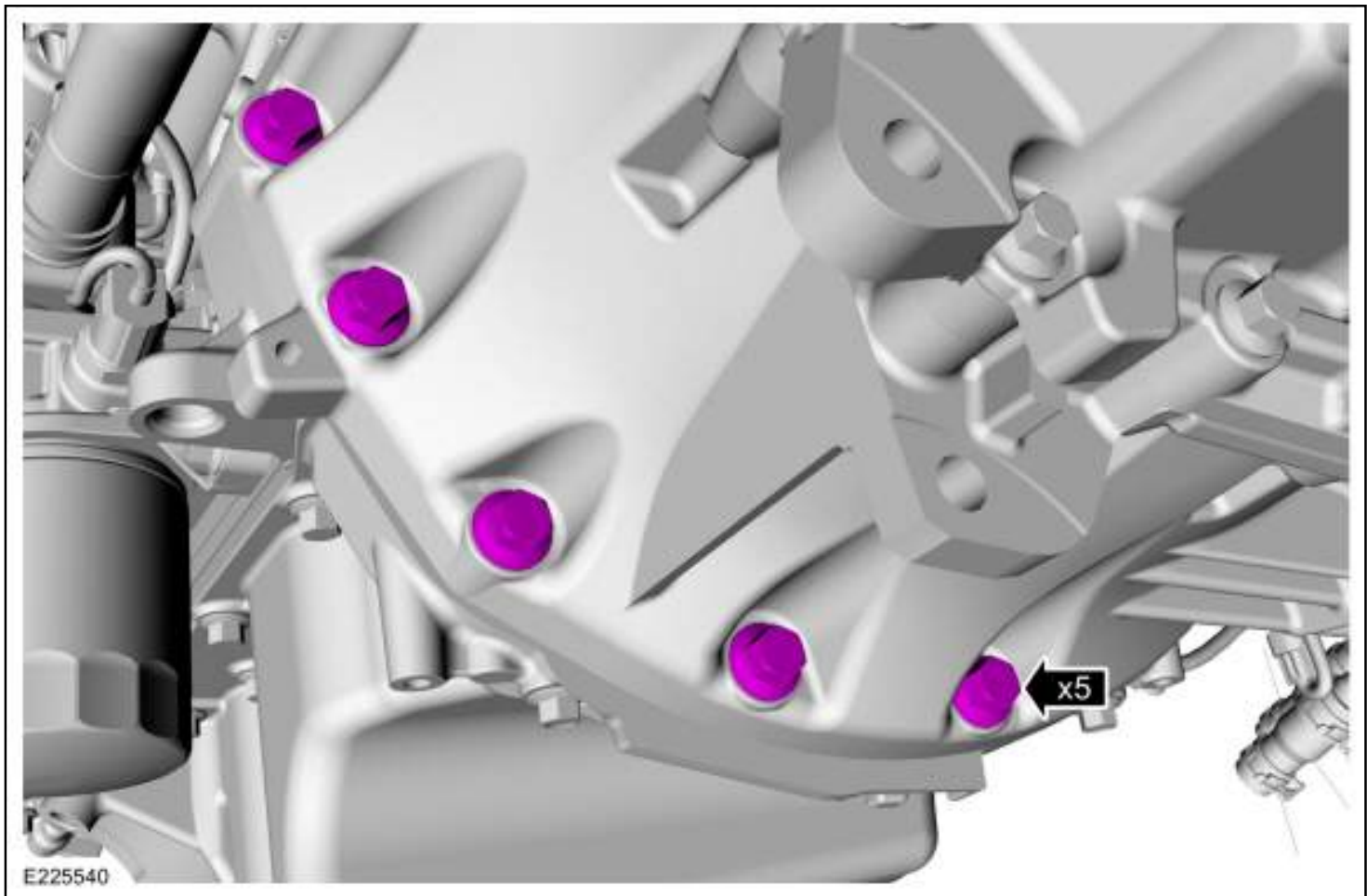

33. **NOTE:** *This step requires the aid of another technician.*

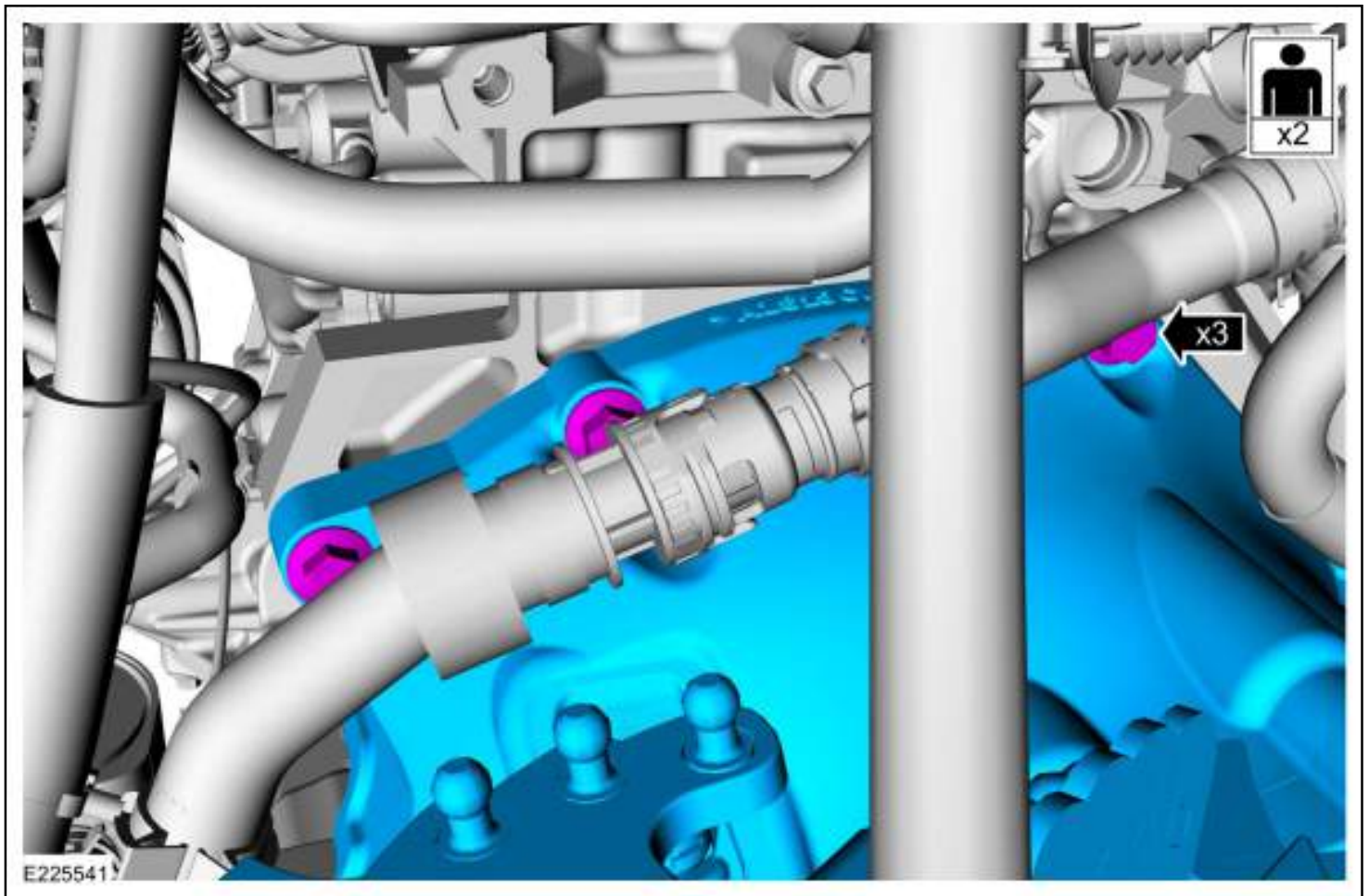

Copyright © 2019 Ford Motor Company

cardiag



# Oil Pump

Base Part Number: Base Part Number: 6621

## Special Tool(s) / General Equipment

Strap Wrench
Plastic Scraper
Oil Drain Equipment
Round-Ended Steel Rule
Fluid Container

## Materials

Name	Specification
Motorcraft® Metal Surface Prep Wipes ZC-31-B	-
Motorcraft® Silicone Gasket and Sealant TA-30	WSE-M4G323-A4

## Removal

1. Refer to: [Timing Chain](#) (303-01C Engine, Removal and Installation).
2. **NOTE:** *Be prepared to collect escaping fluid.*

Use the General Equipment: Oil Drain Equipment  
*Torque:* 19 lb.ft (26 Nm)

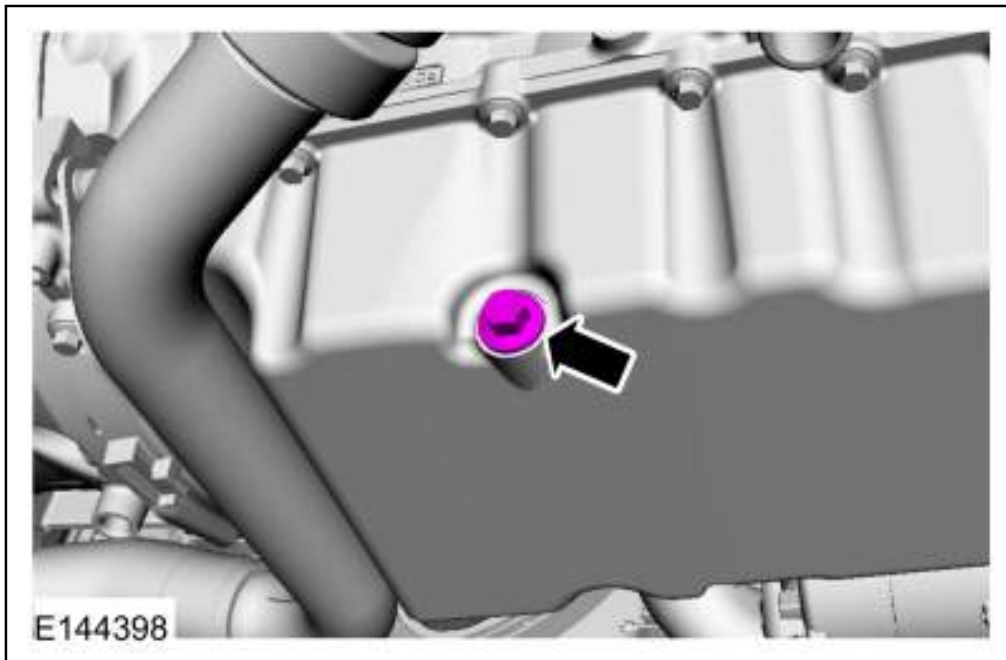

3. Use the General Equipment: Fluid Container  
Use the General Equipment: Strap Wrench

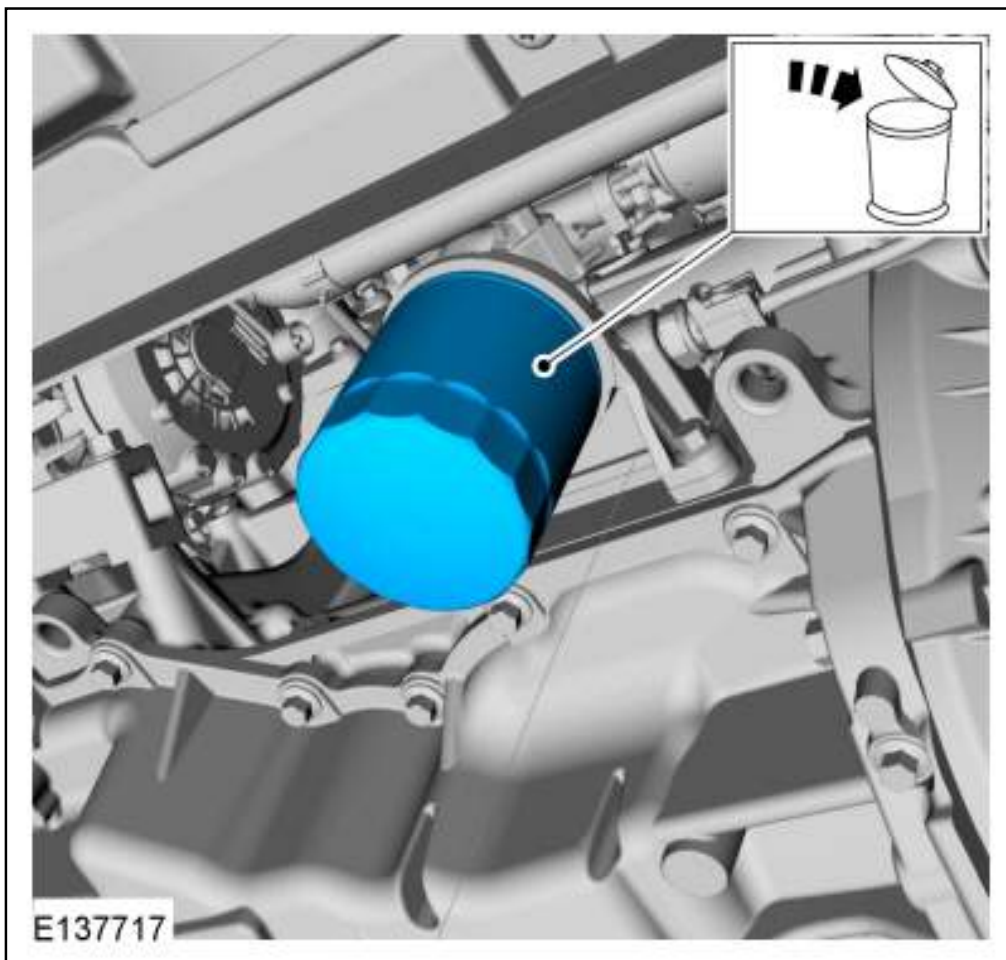

4. **NOTICE:** Make sure that no strain is placed on the refrigerant lines.

*Torque:* 18 lb.ft (25 Nm)

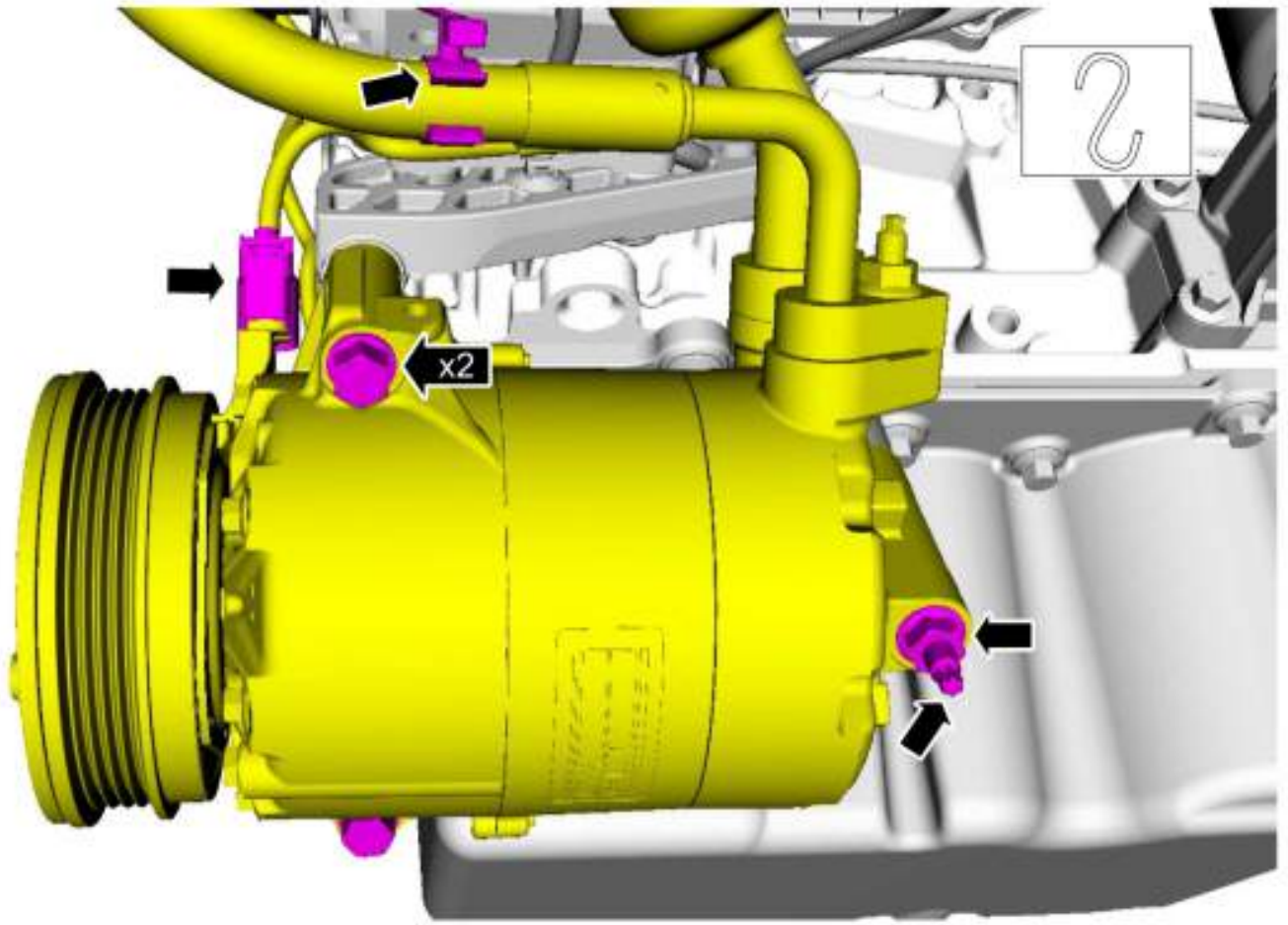

5. Torque: 35 lb.ft (48 Nm)



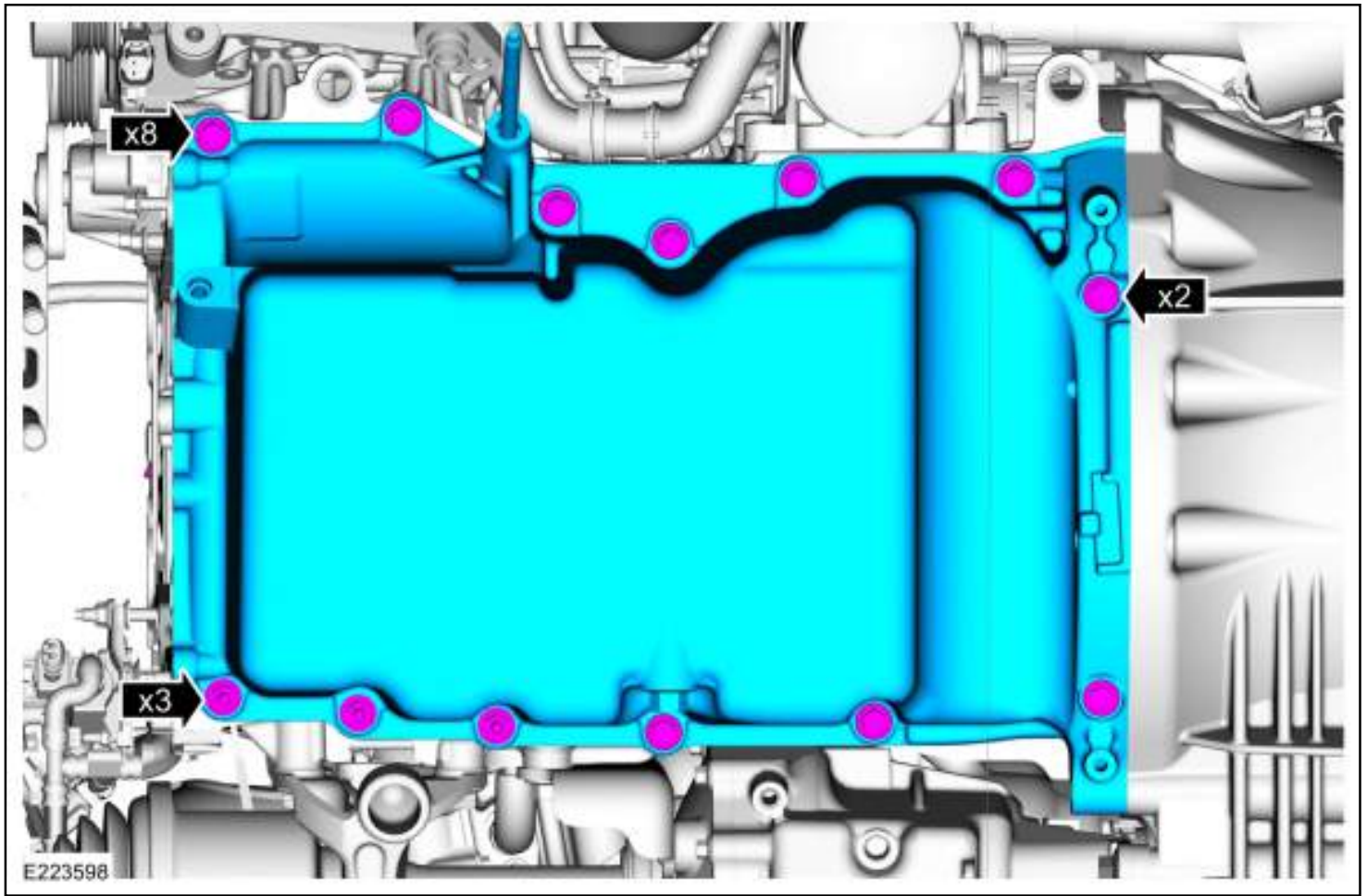

6.

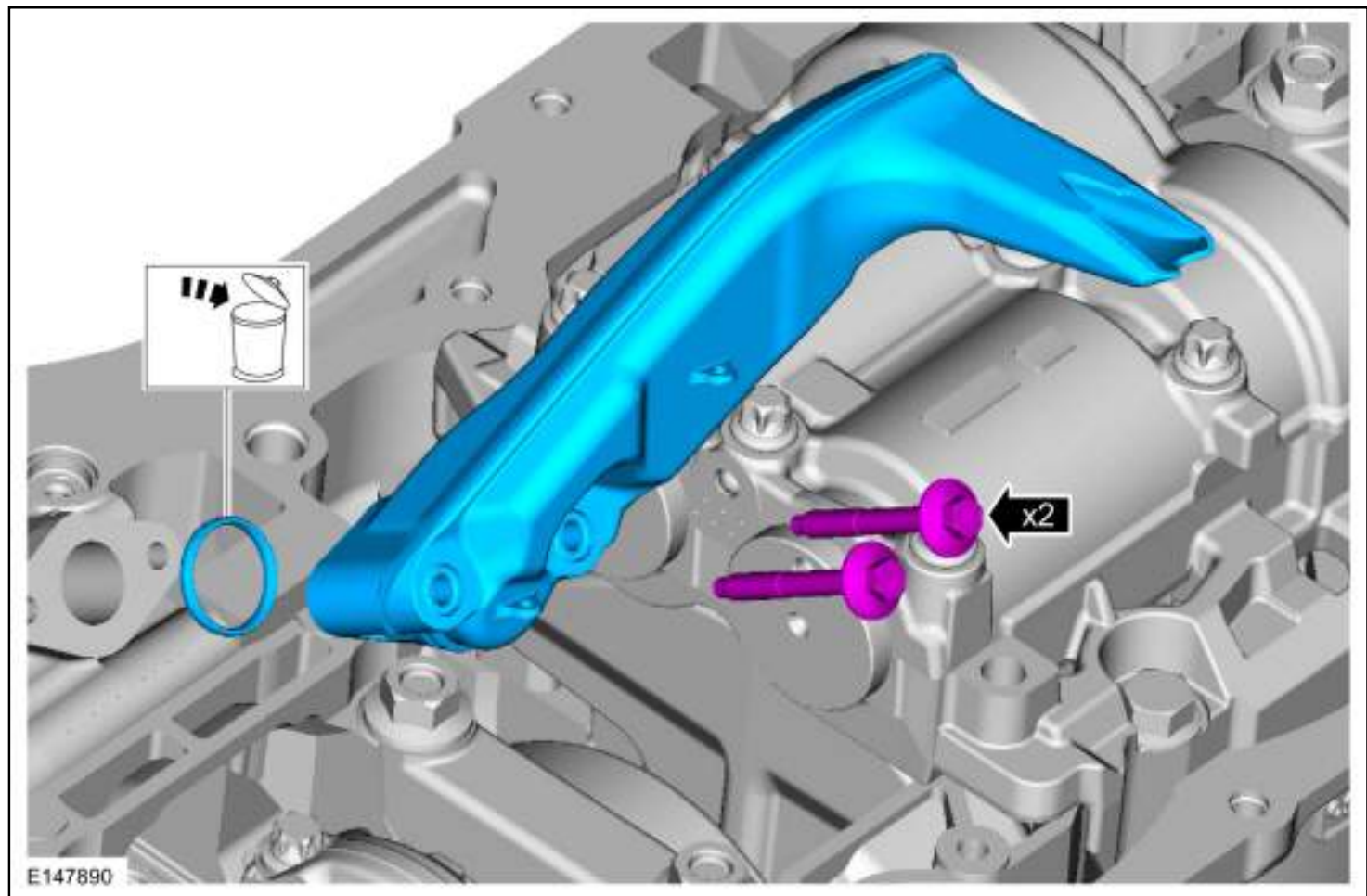

7. **NOTE:** Make sure that a new O-ring is installed.

*Torque:* 89 lb.in (10 Nm)



8.  **WARNING: The tensioner is under spring tension. Be careful when handling the tensioner. Failure to follow this instruction may result in personal injury.**

*Torque: 89 lb.in (10 Nm)*

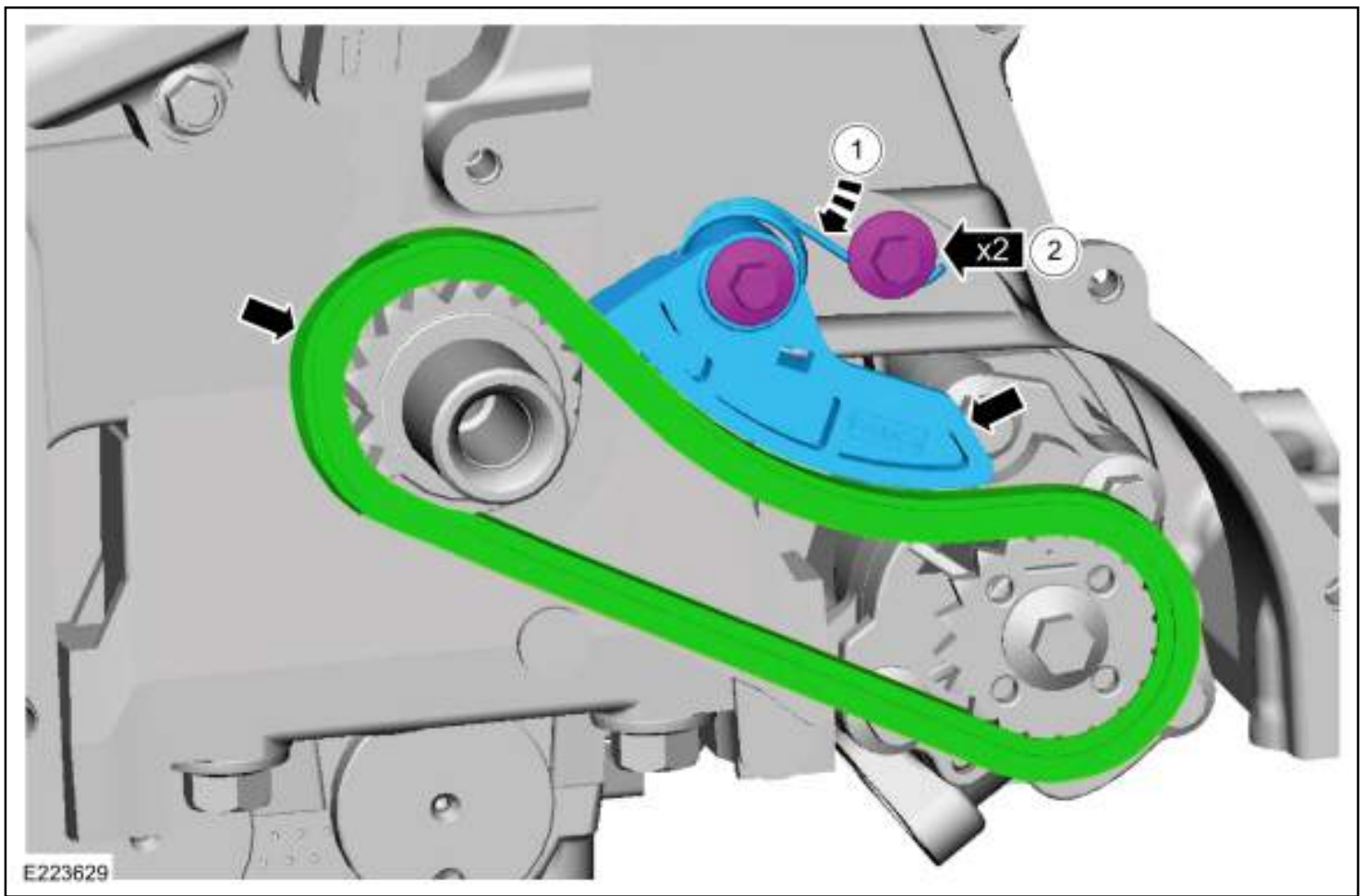

9. **NOTE:** *Discard the friction washer.*

If equipped.

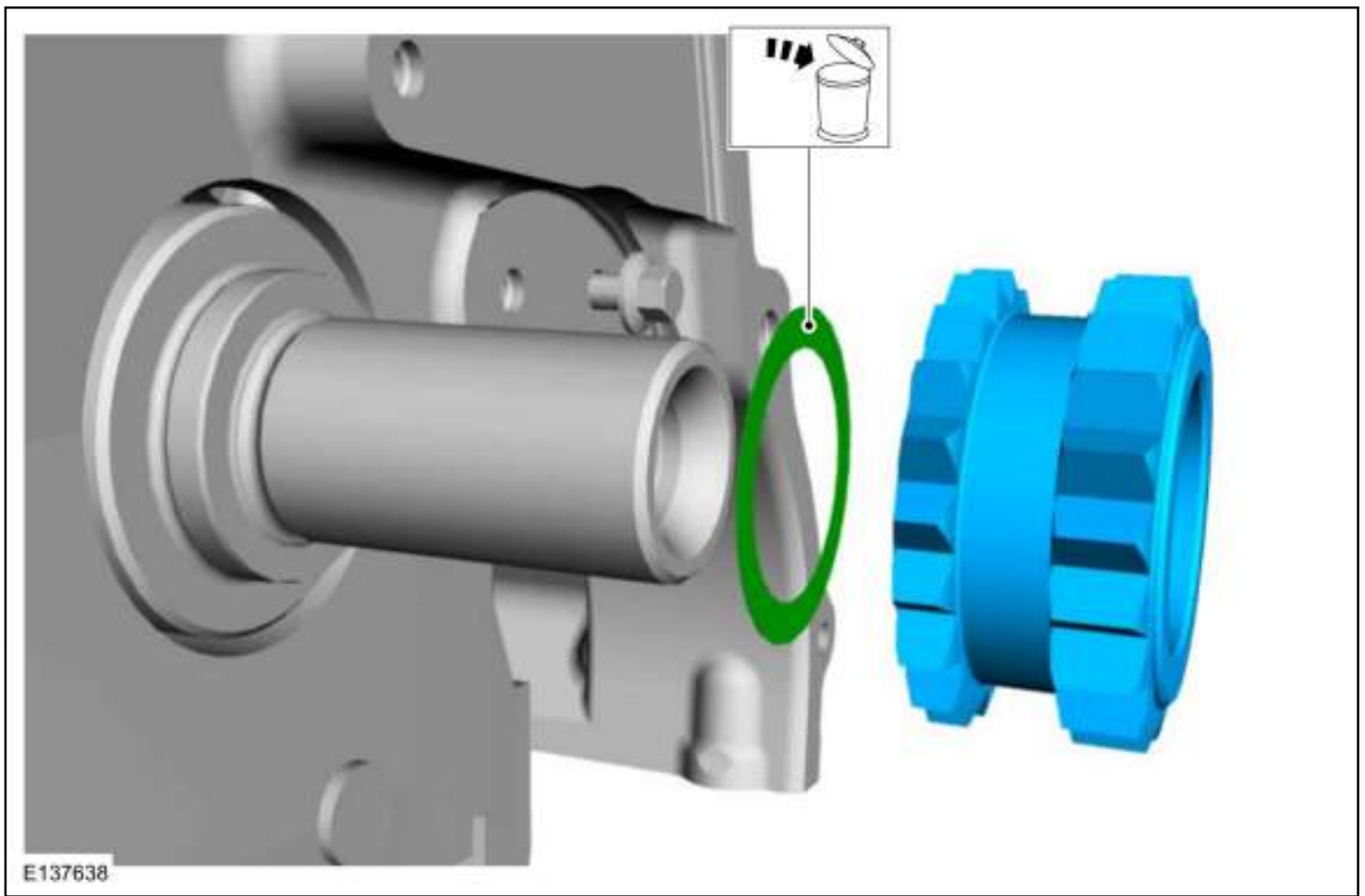

10. *Torque:* 18 lb.ft (25 Nm)

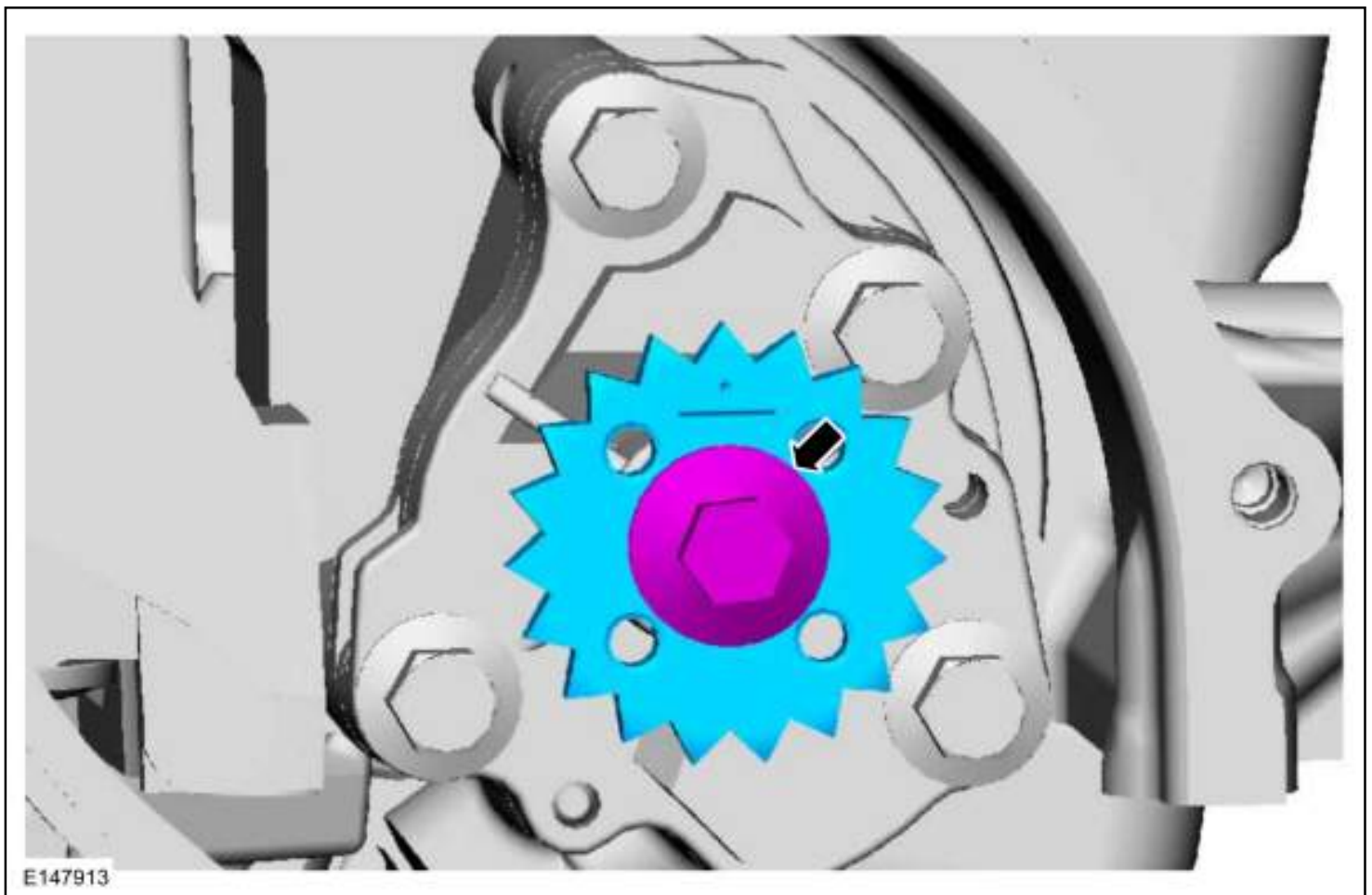

cardiagn.

## 11. Torque:

Stage 1: 89 lb.in (10 Nm)

Stage 2: 177 lb.in (20 Nm)

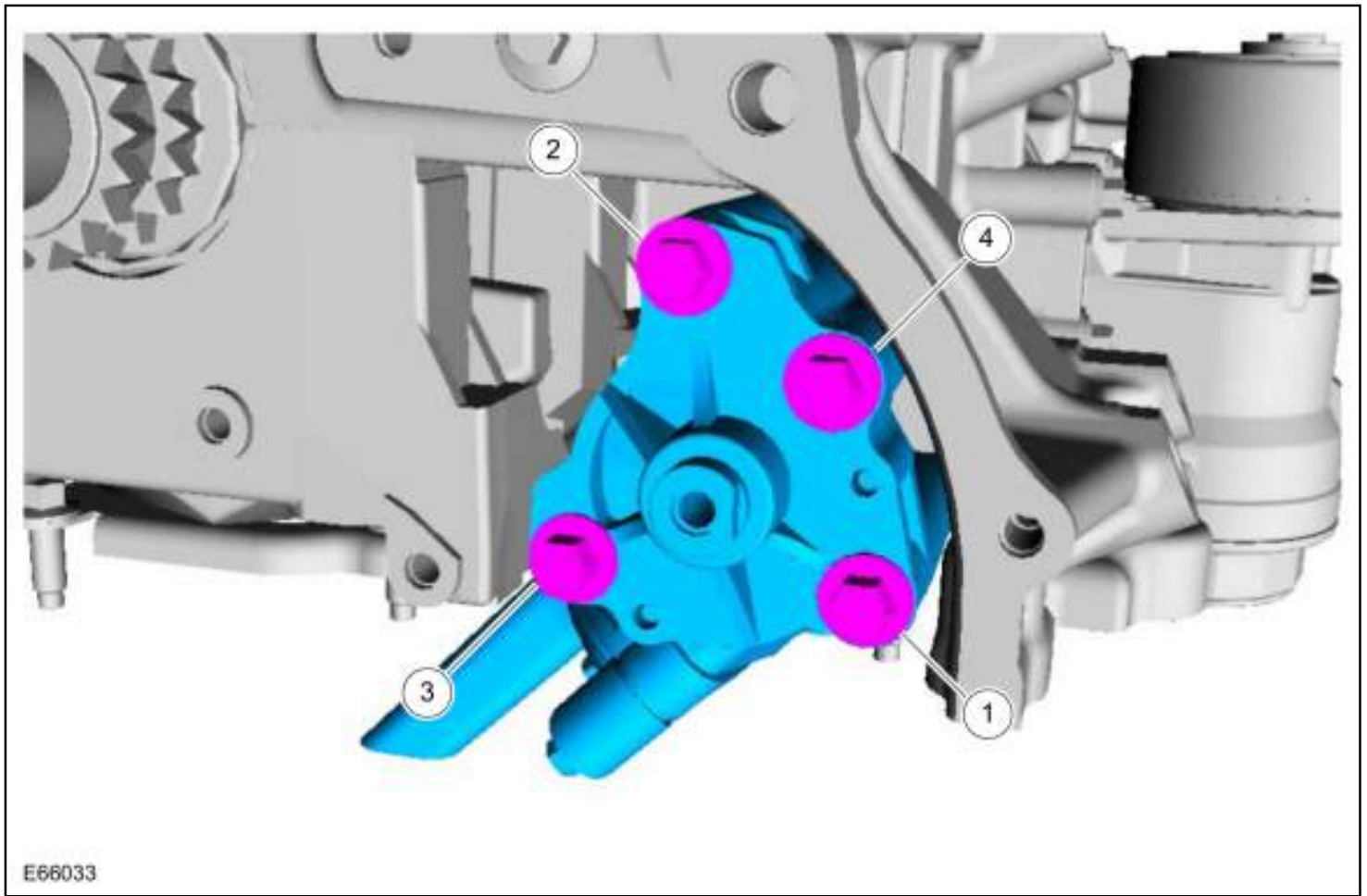

## Installation

1. To install, reverse the removal procedure.

1. Flat faced sprocket – requires new friction washer.
2. Laser etched sprocket – does **NOT** require friction washer.

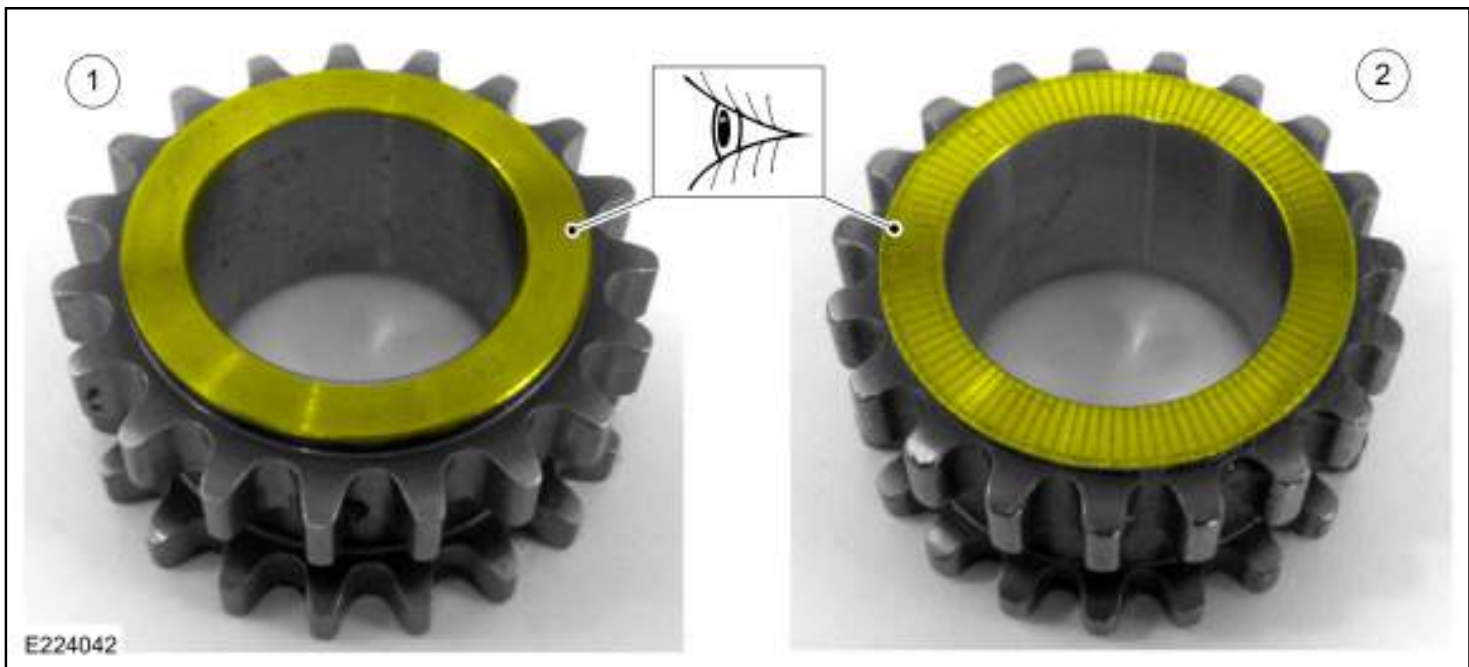

3. **NOTICE:** Make sure that a new friction washer is installed.

If equipped with flat faced sprocket.

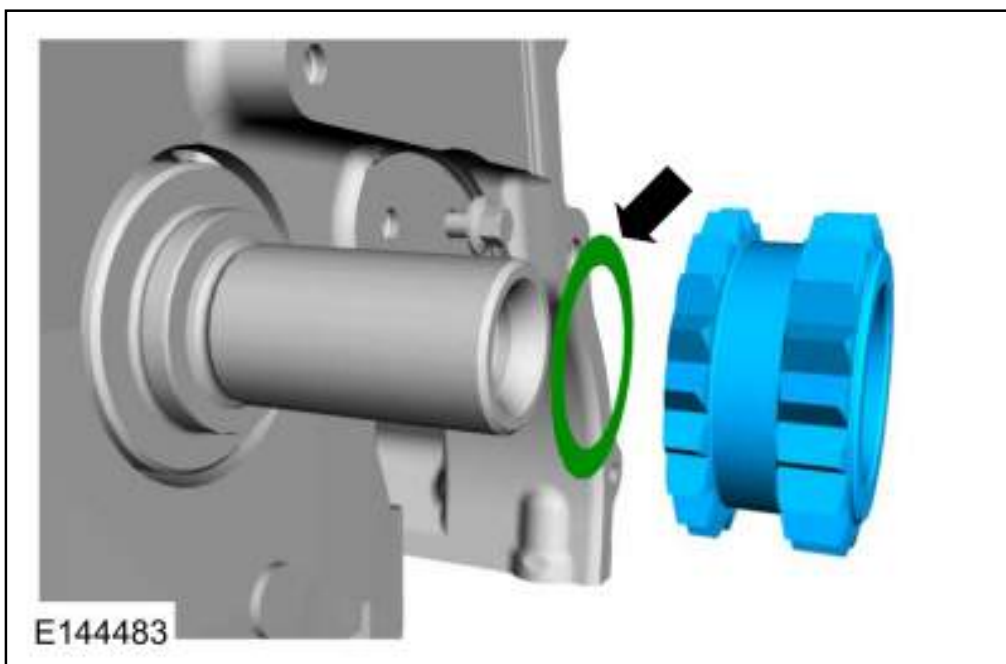

4. **NOTE:** Make sure that the mating faces are clean and free of foreign material.

Use the General Equipment: Plastic Scraper

Material: Motorcraft® Metal Surface Prep Wipes / ZC-31-B

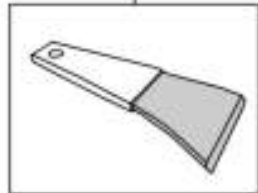

N0152516



5. **NOTE:** Make sure that the mating faces are clean and free of foreign material.

Use the General Equipment: Plastic Scraper

Material: Motorcraft® Metal Surface Prep Wipes / ZC-31-B

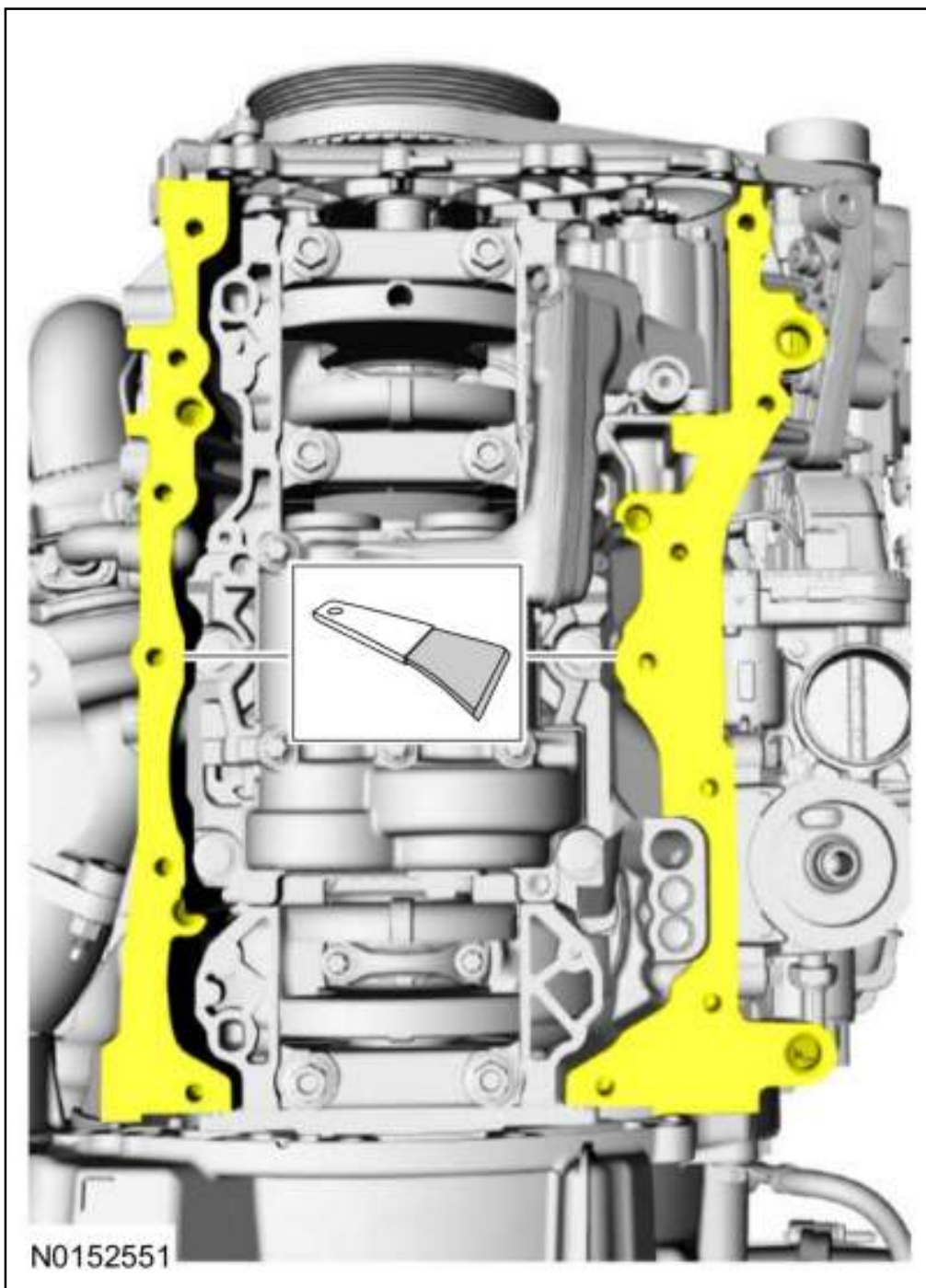

6. **NOTE:** *The component must be installed within 10 minutes of applying the sealant.*

*Material:* Motorcraft® Silicone Gasket and Sealant / TA-30 (WSE-M4G323-A4)

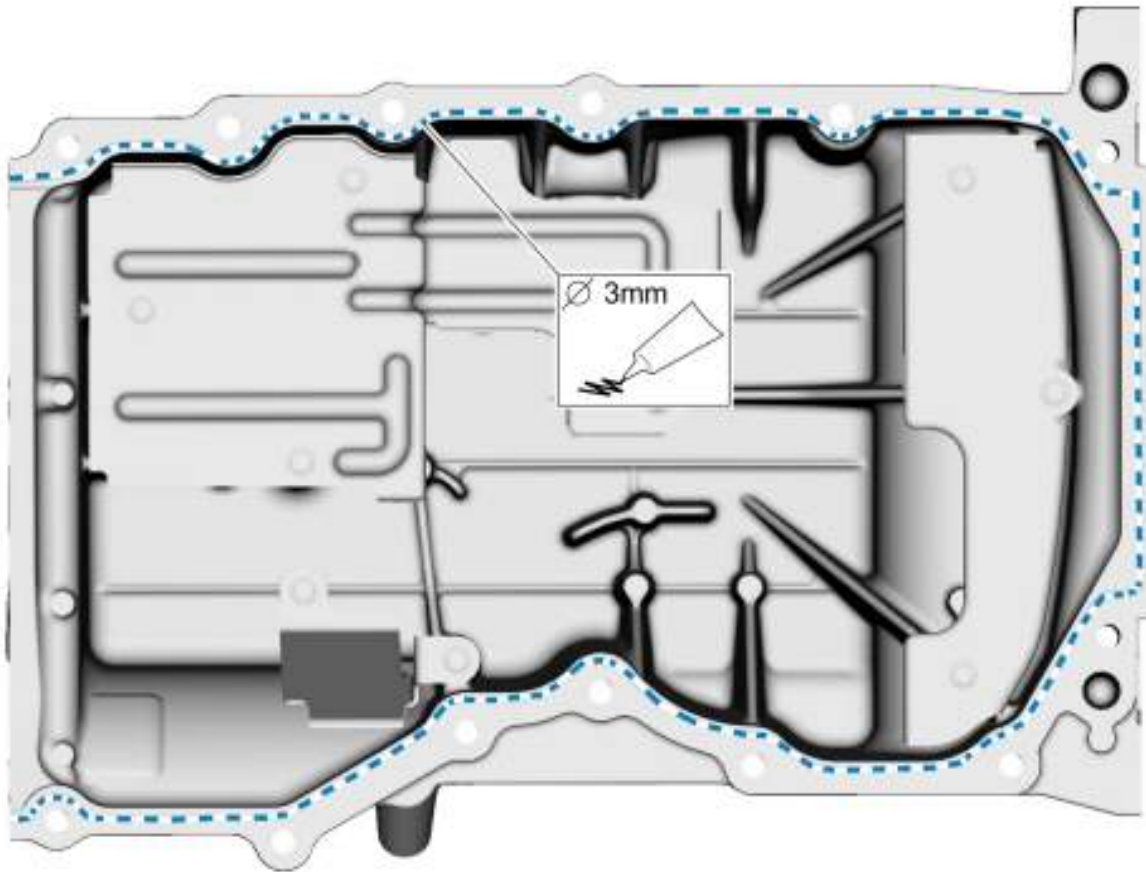

E144415

7. **NOTE:** Only tighten the bolts finger tight at this stage.

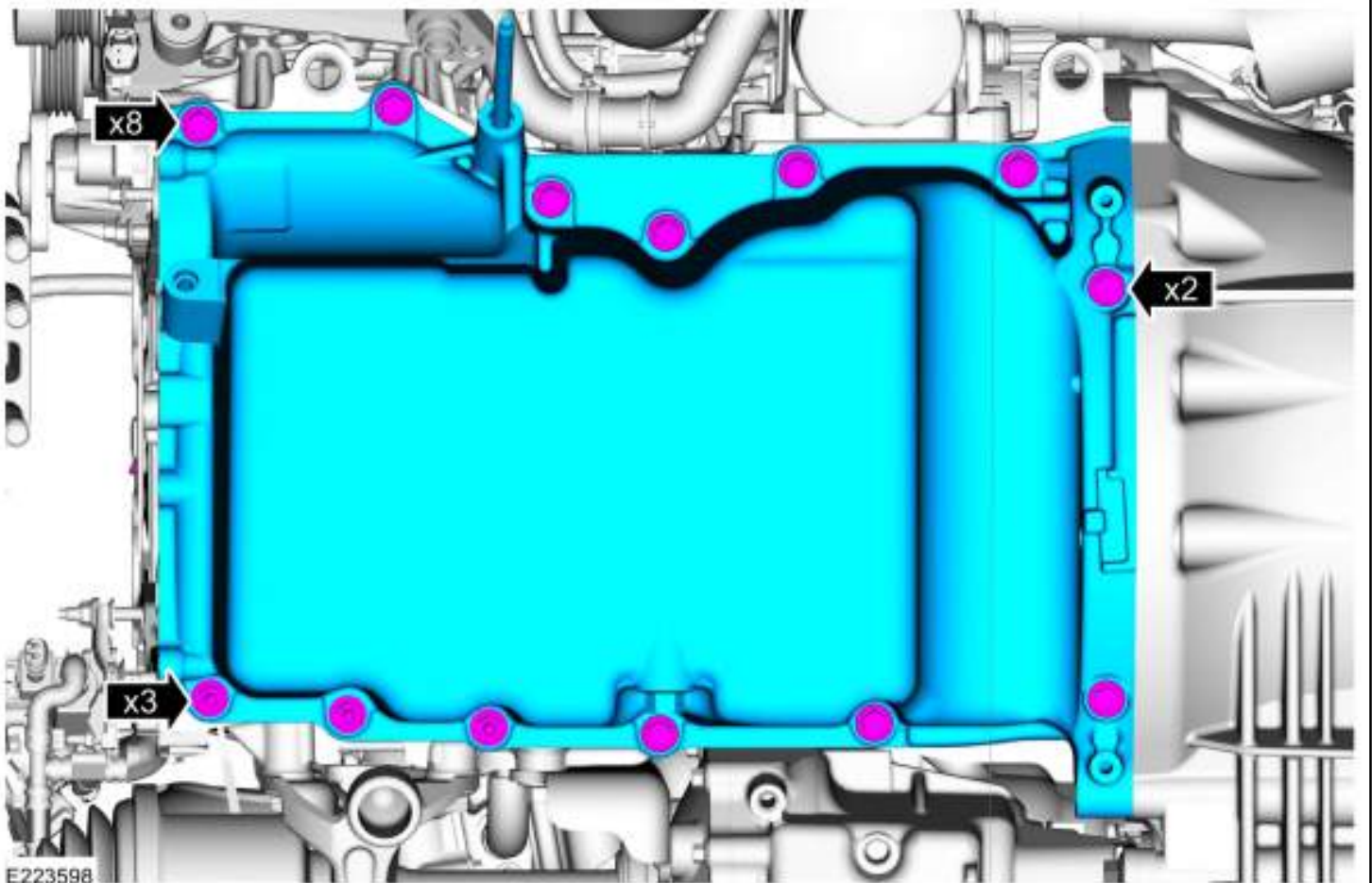

E223598

8. Use the General Equipment: Round-Ended Steel Rule

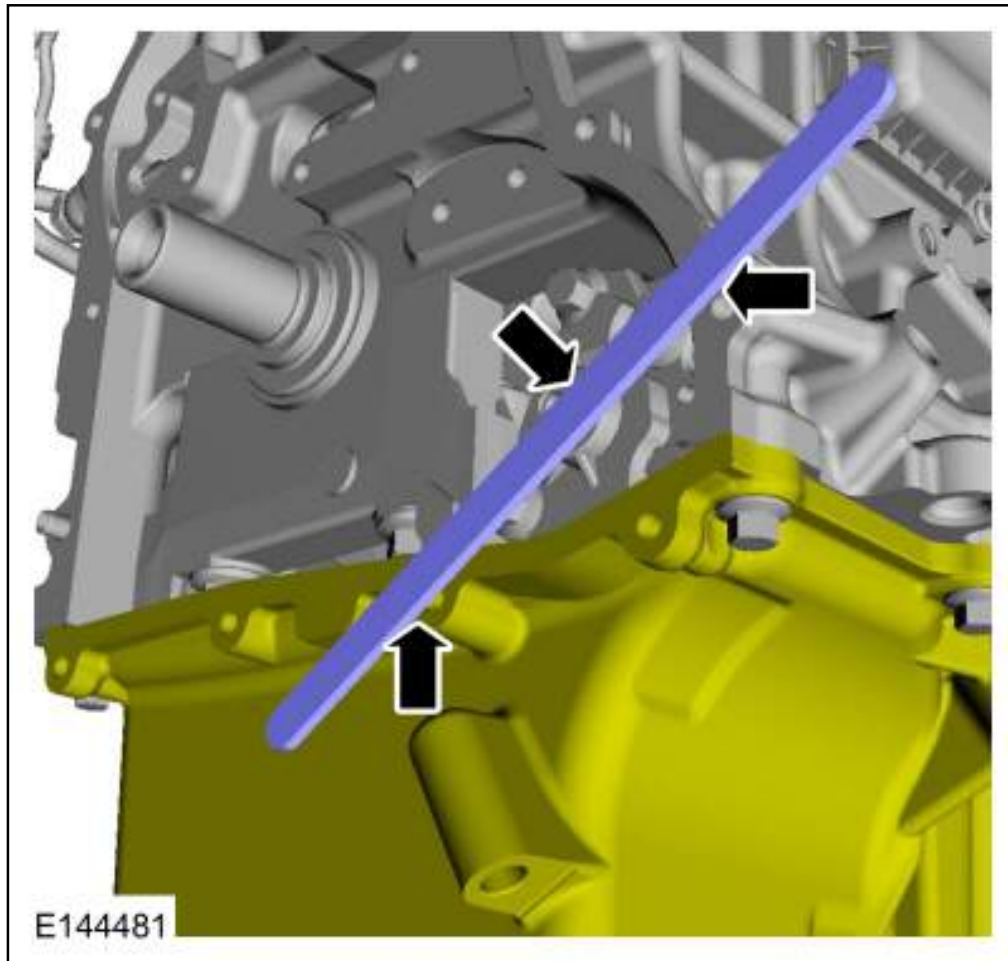

9. *Torque*: 177 lb.in (20 Nm)

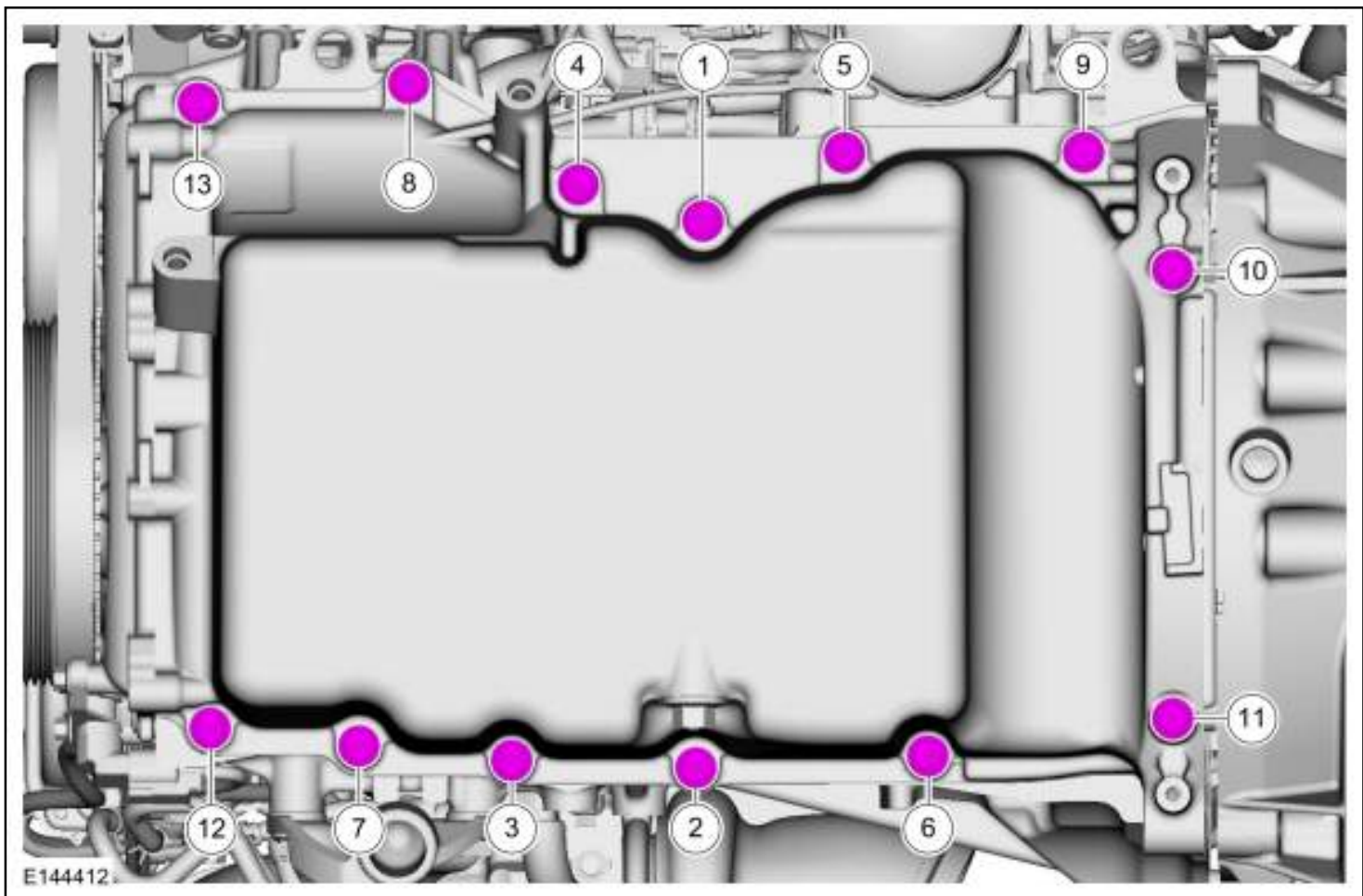

10. **NOTE:** *Component must be lubricated with clean engine oil.*

**NOTE:** *Make sure that a new component is installed.*

*Torque: 133 lb.in (15 Nm)*



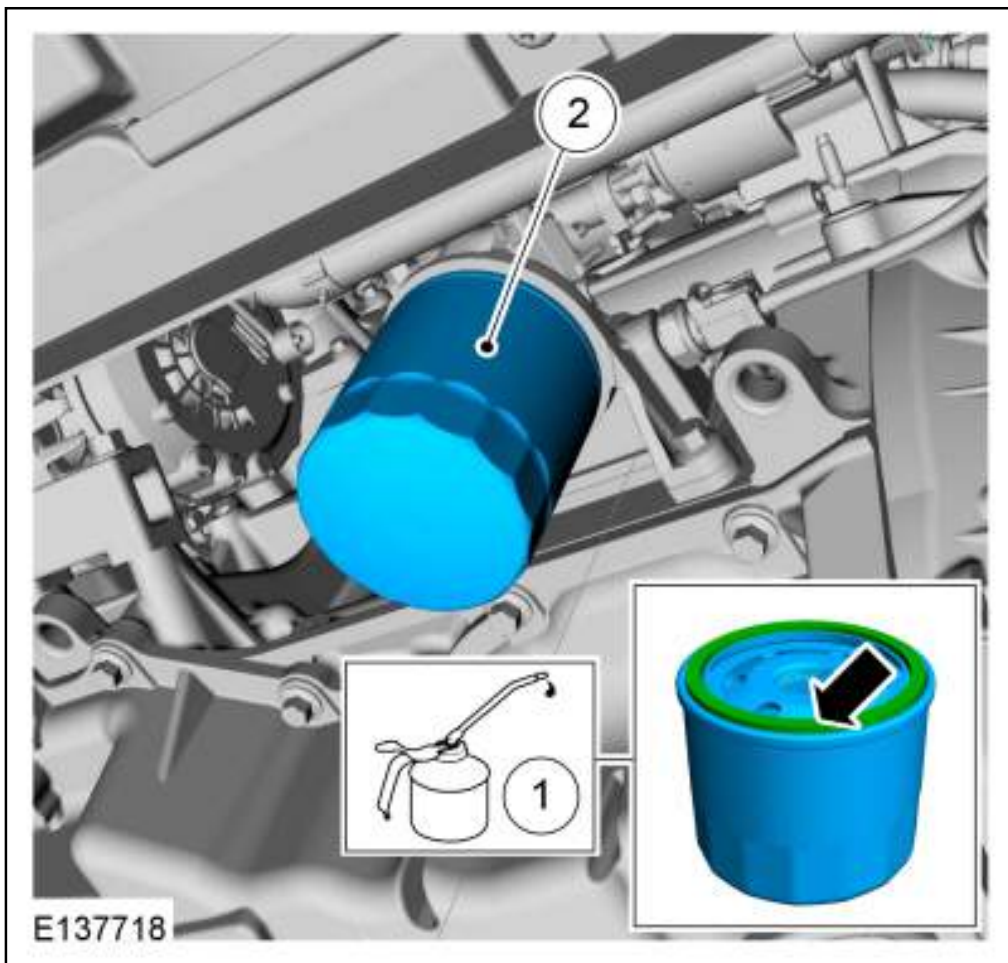

11. Refer to: [Specifications](#) (303-01E Engine - 2.3L EcoBoost (257kW/350PS) - MI4, Specifications).

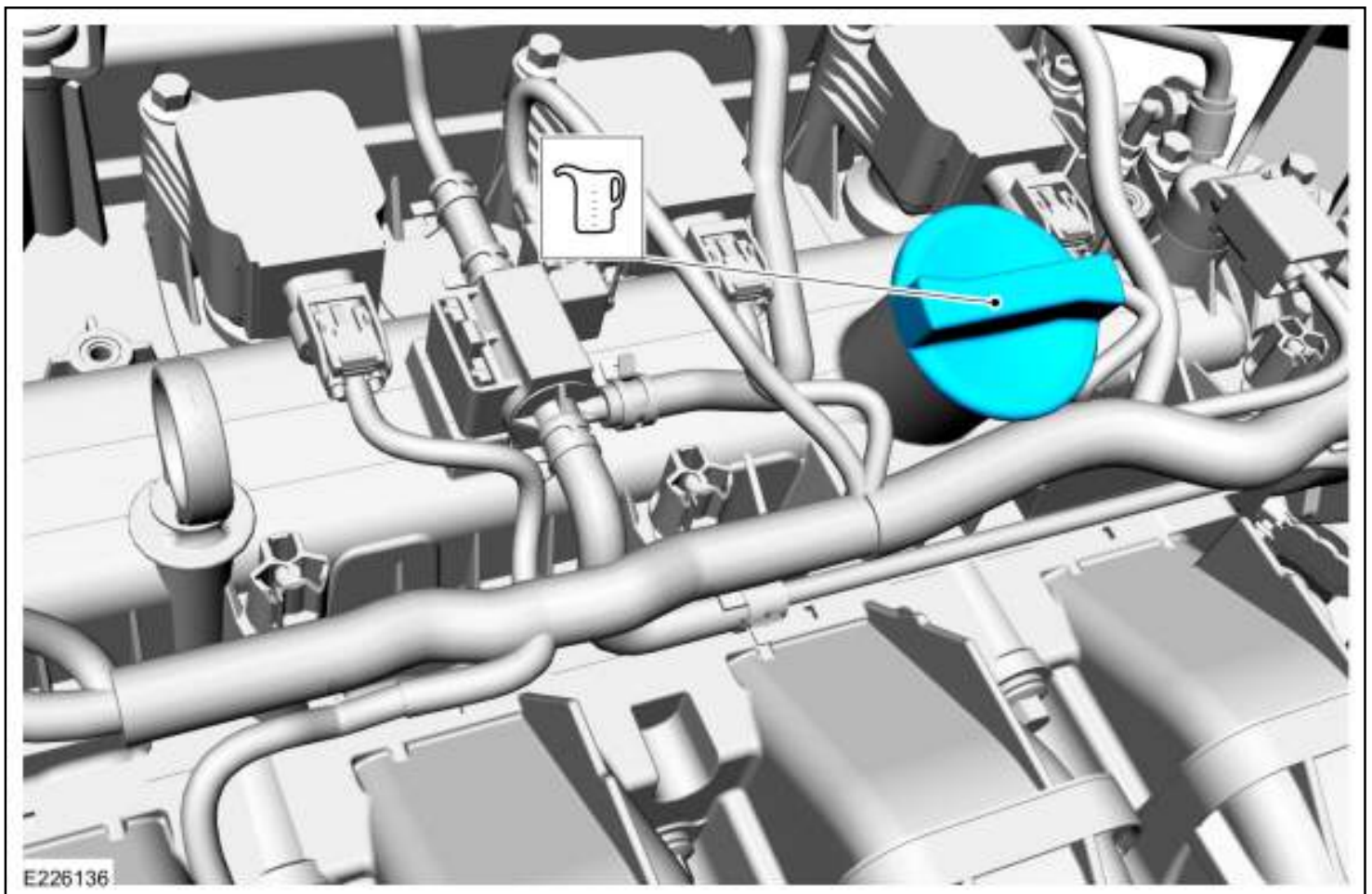





## Crankshaft Front Seal

Base Part Number: Base Part Number: 6700

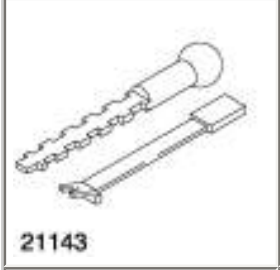
### Special Tool(s) / General Equipment

 <p>21143</p>	<p>303-293 Remover, Crankshaft Seal</p>
 <p>IA21213</p>	<p>303-509 Remover, Vibration Damper Hub</p>

### Removal

1. Refer to: [Crankshaft Pulley](#) (303-01C Engine, Removal and Installation).
2. Use Special Service Tool: 303-293 Remover, Crankshaft Seal.

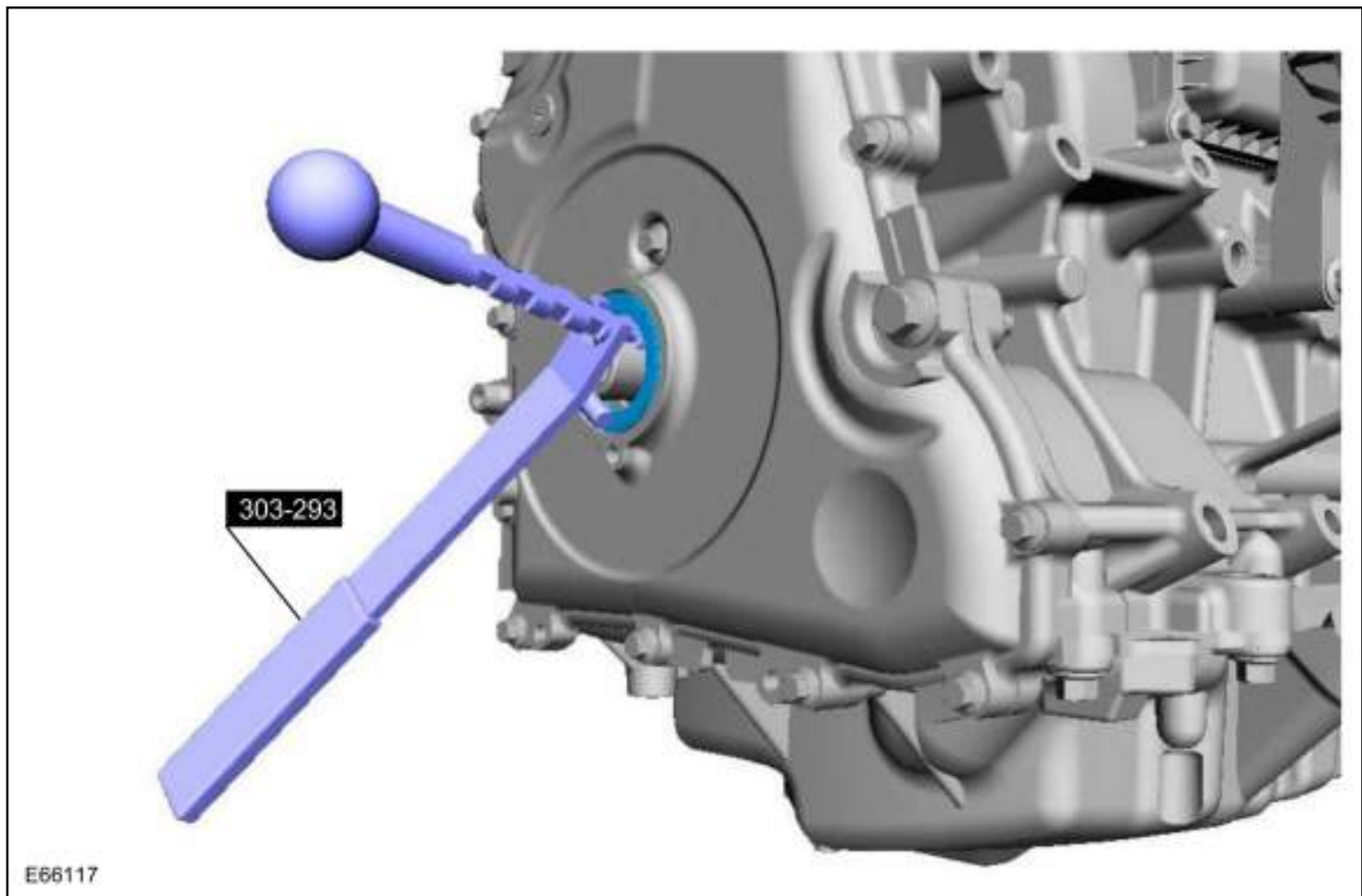

3. **NOTE:** *Discard the friction washer.*

If equipped.

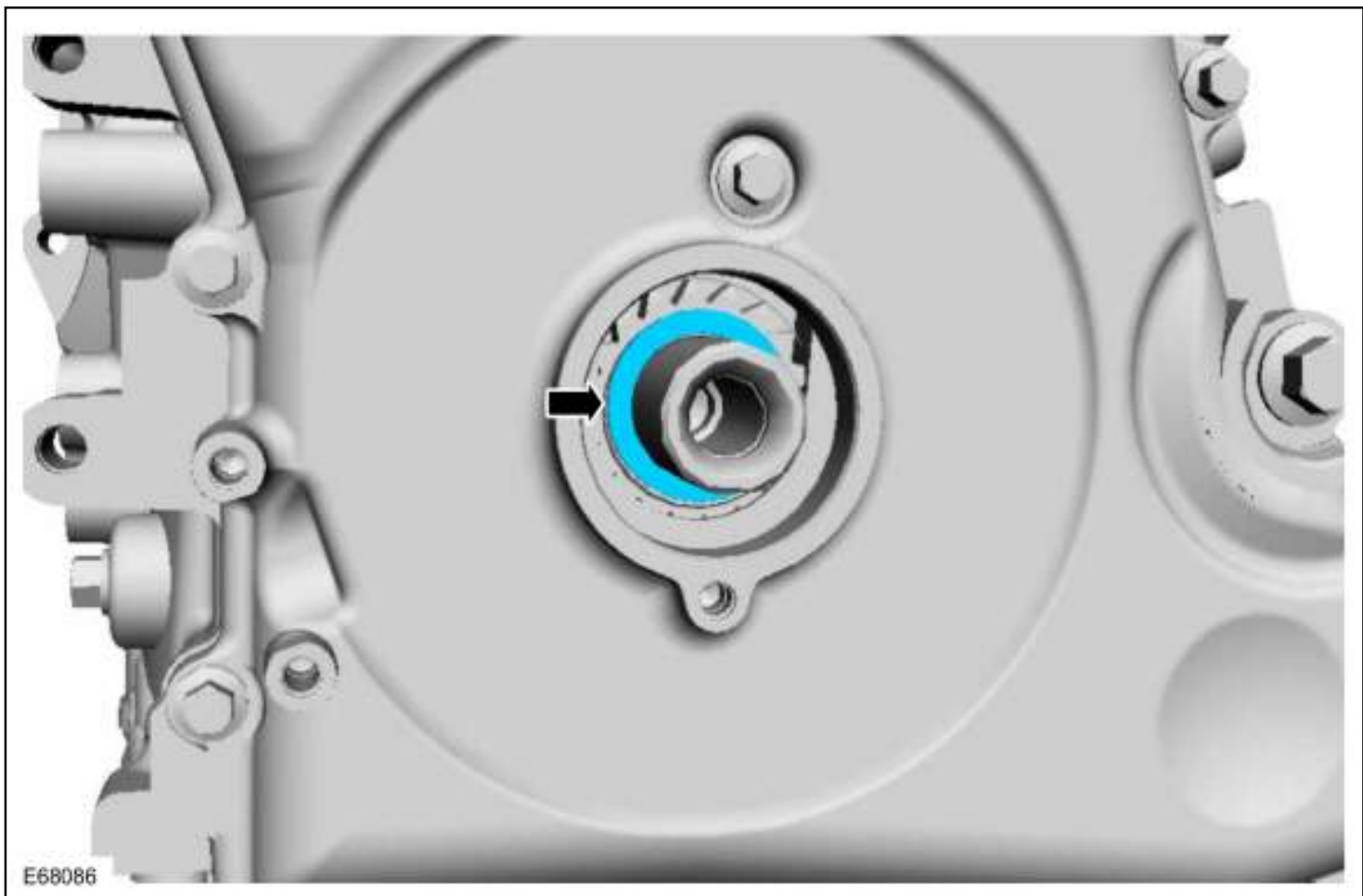

## Installation

1. Flat faced sprocket – requires new friction washer.
2. Laser etched sprocket – does **NOT** require friction washer.

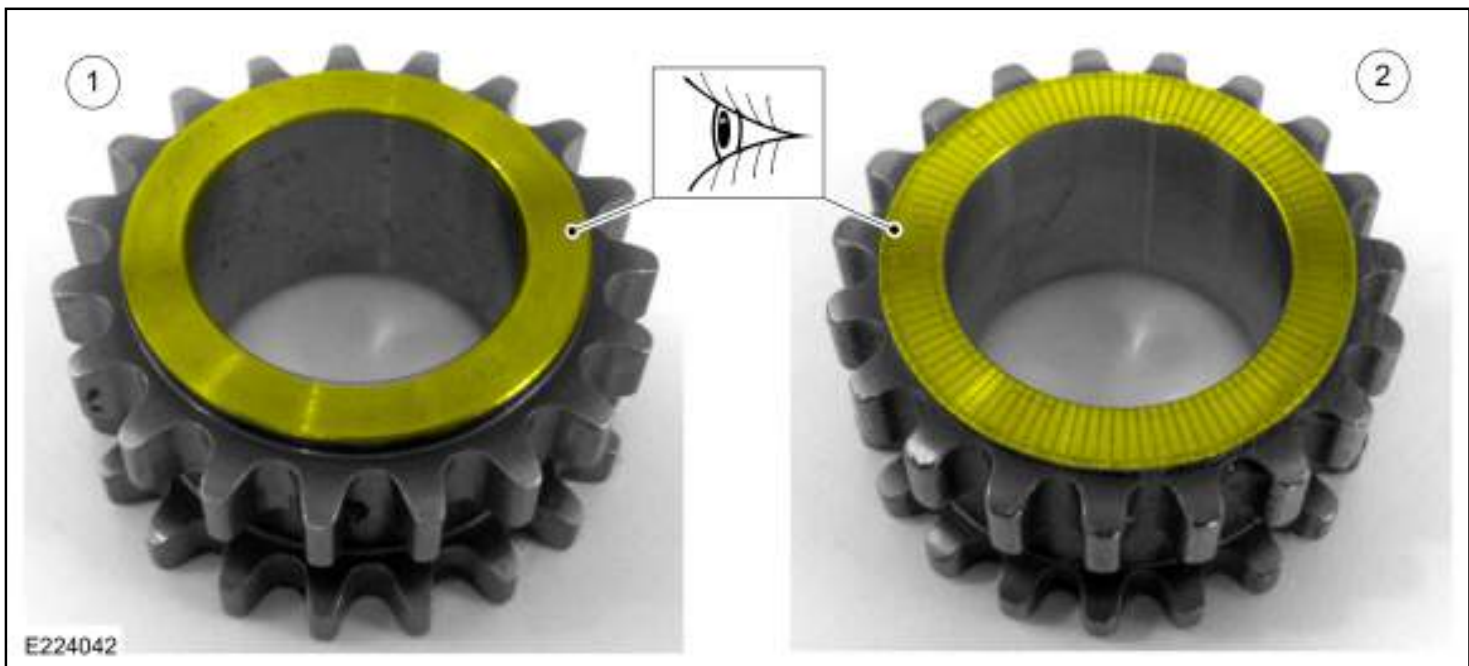

2. **NOTICE: Make sure that a new friction washer is installed.**

If equipped with flat faced sprocket.

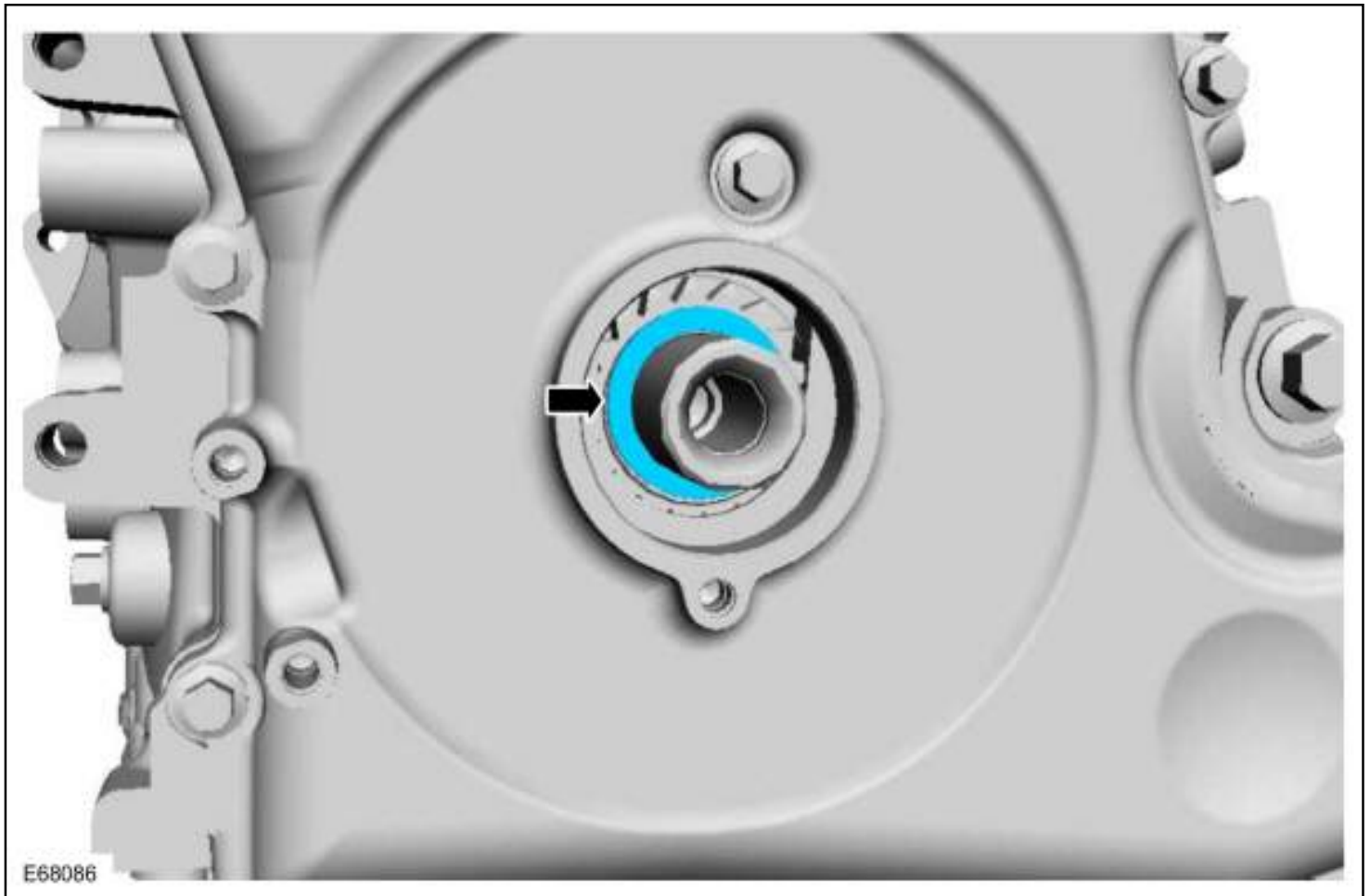

3. **NOTICE: Make sure a new component is installed.**

Use Special Service Tool: 303-509 Remover, Vibration Damper Hub.

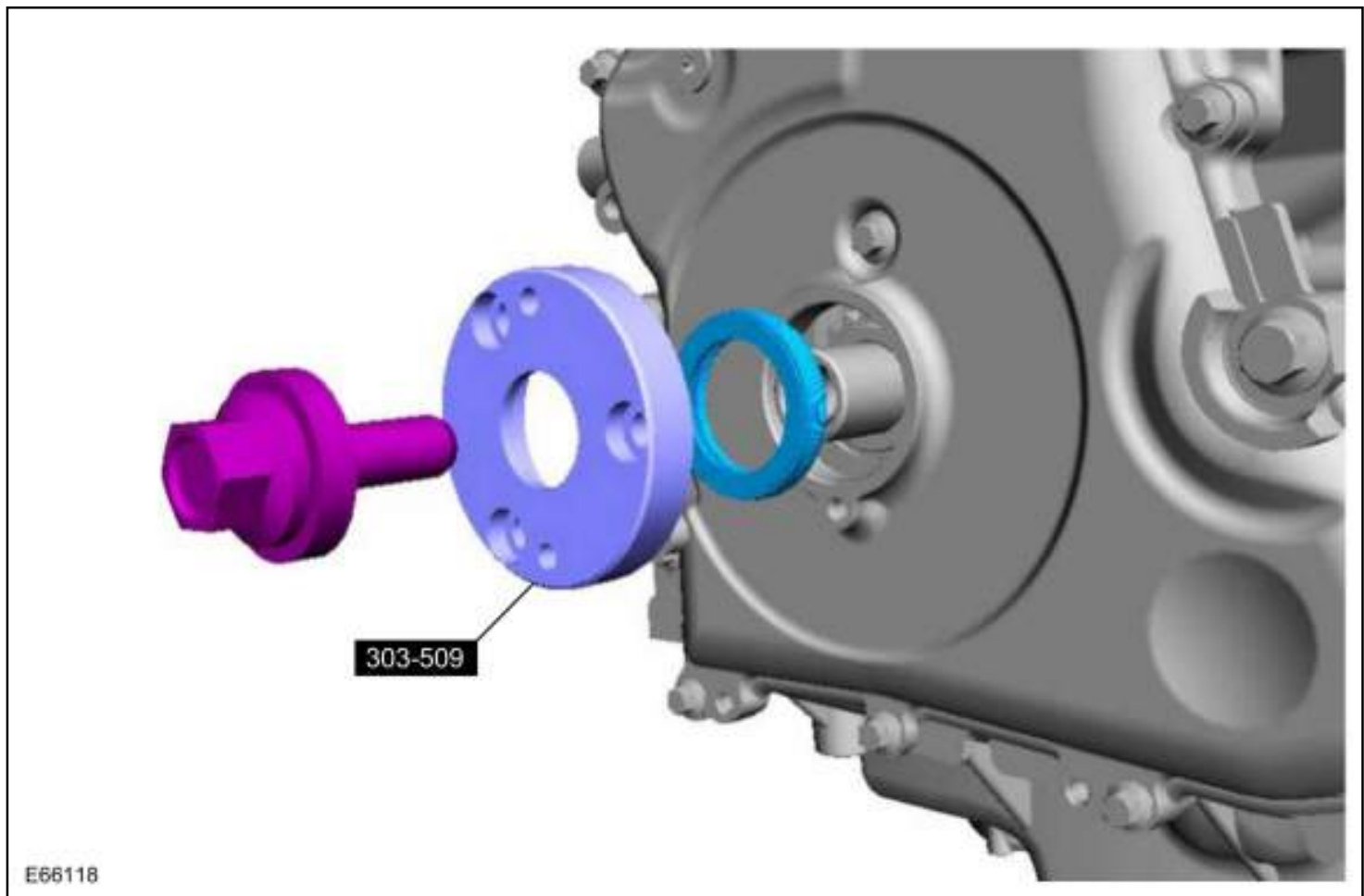

4. Refer to: [Crankshaft Pulley](#) (303-01C Engine, Removal and Installation).

Copyright © 2019 Ford Motor Company



## Camshafts

### Special Tool(s) / General Equipment

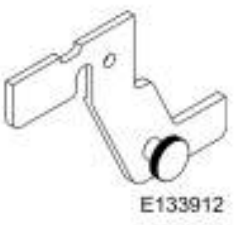
 <p>E133912</p>	303-1565 Alignment Tool, Camshaft TKIT-2010C-FLM
Vise	
Vise Jaw Protectors	

### Materials

Name	Specification
Flange Sealant CU7Z-19B508-A	WSS-M2G348-A11

### Removal

**NOTE:** Removal steps in this procedure may contain installation details.

1. Refer to: [Timing Chain](#) (303-01C Engine, Removal and Installation).
2. Remove Special Service Tool: 303-1565 Alignment Tool, Camshaft.

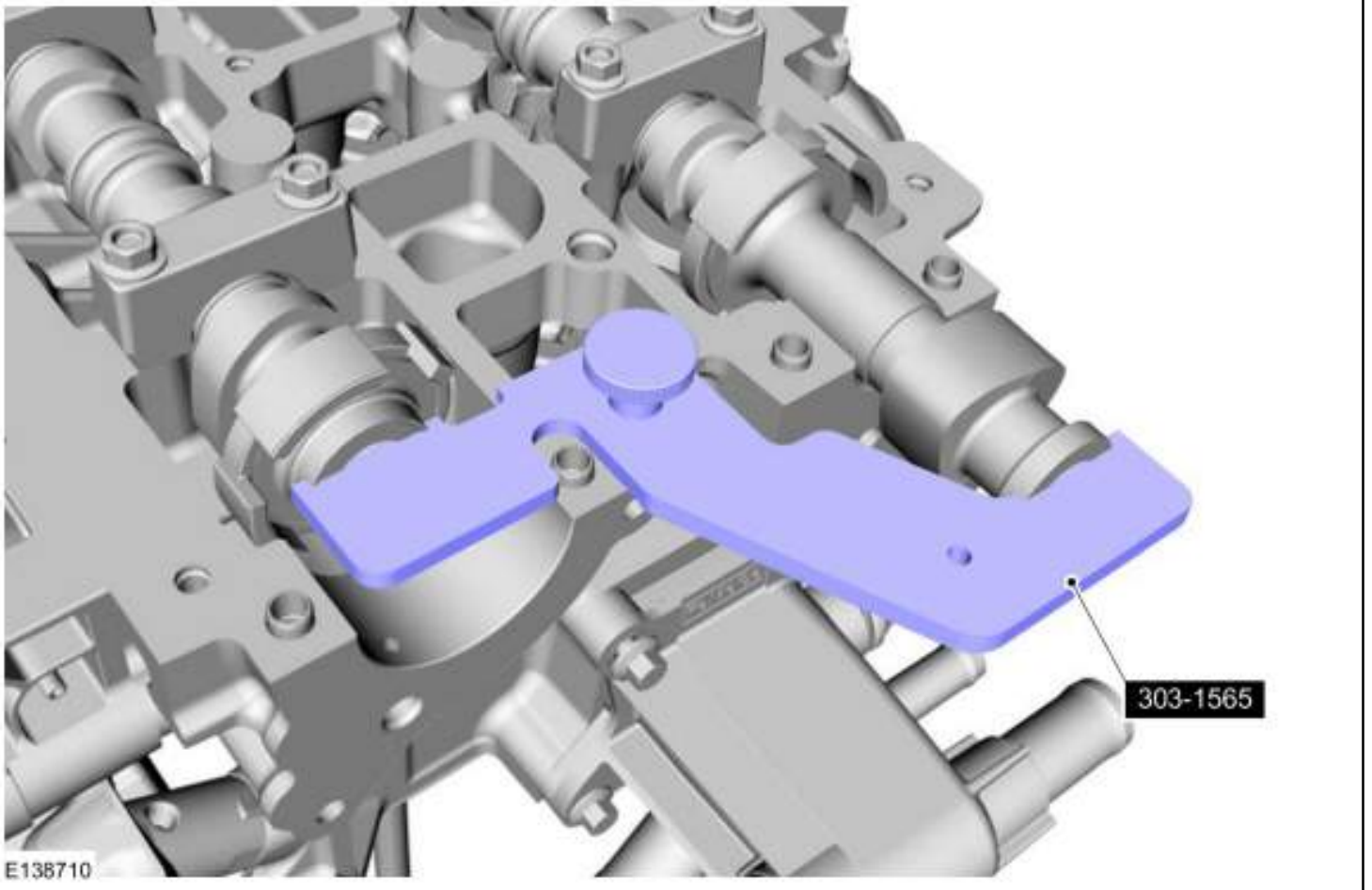

3. **NOTE:** Note the position of the components before removal.

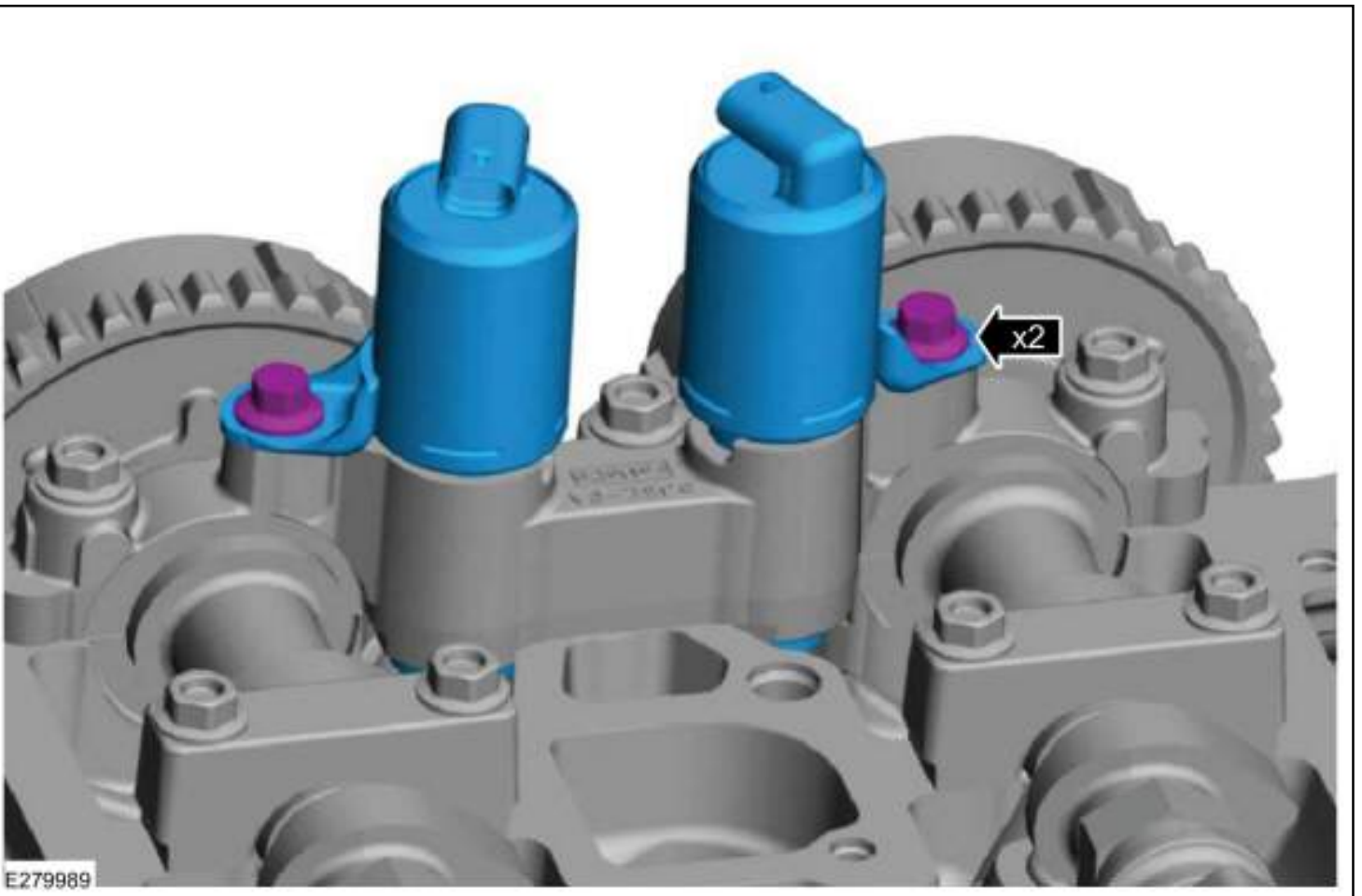

4. Loosen each bolt 2 turns at a time until all bolts are removed.

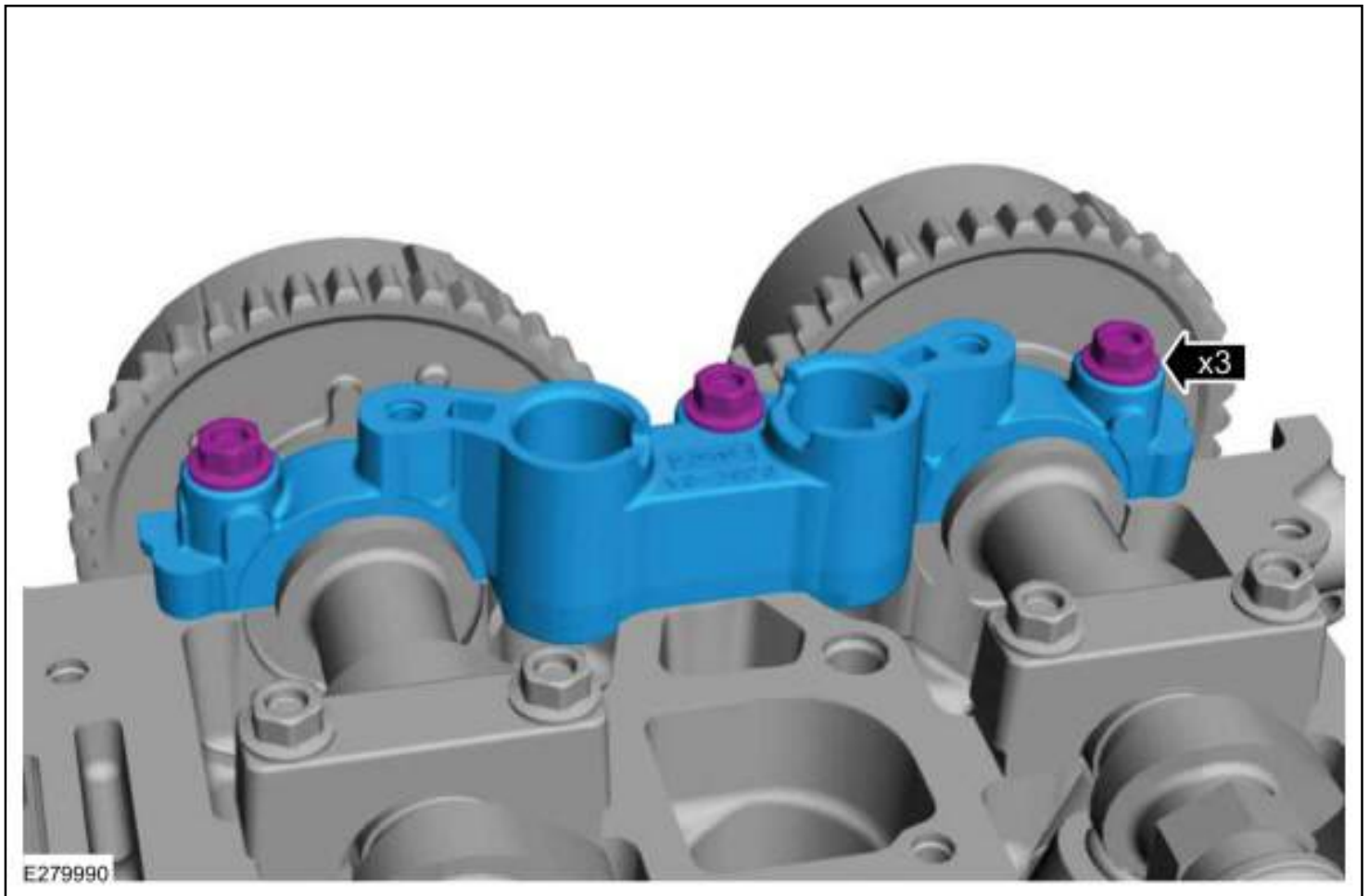

5. **NOTE:** *Note the position of the components before removal.*

Loosen each bolt 2 turns at a time until all bolts are removed.

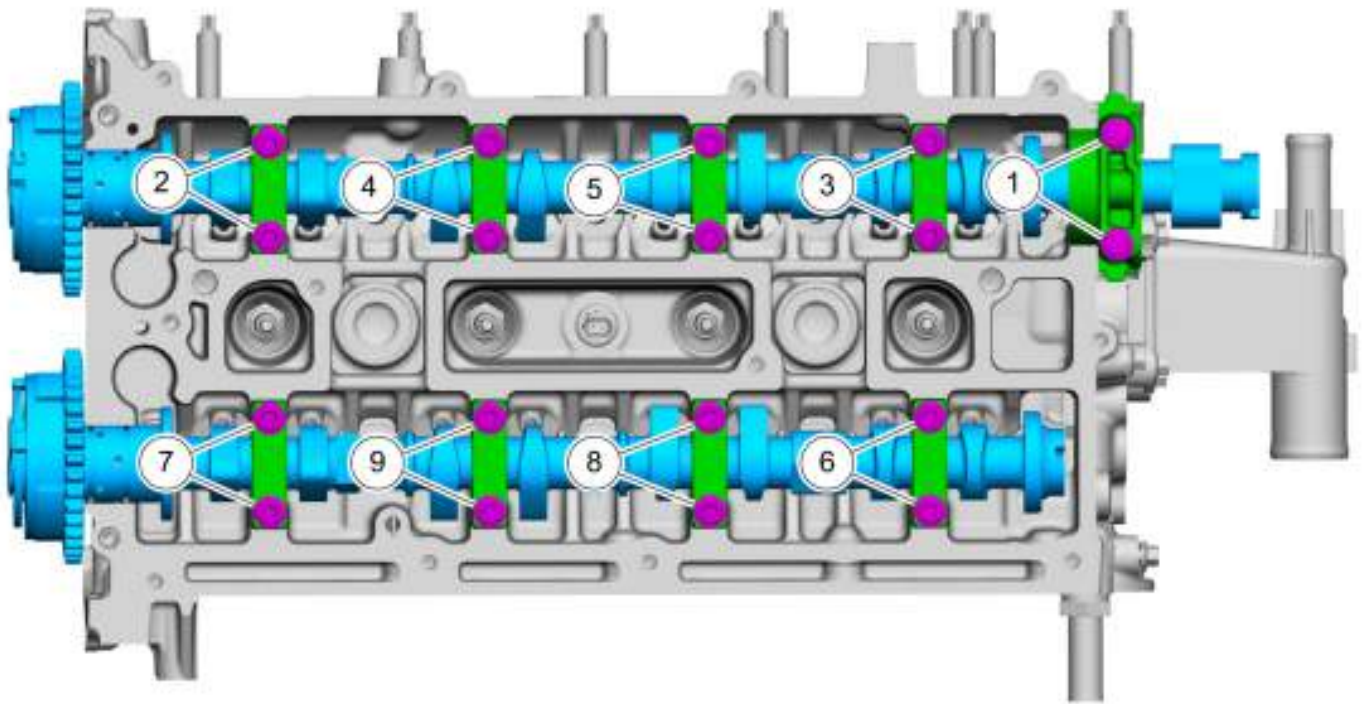

E279744

6. **NOTE:** *This step is only necessary if the camshafts are being serviced.*

**NOTE:** *Discard the bolts.*

**NOTE:** *Note the position of the components before removal.*

Use the General Equipment: Vise

Use the General Equipment: Vise Jaw Protectors





### Installation

**NOTE:** *If any new parts are being installed (cylinder head, valves, tappets, camshafts) it is necessary to check the valve clearance. If the original parts are being installed it is not necessary to check the valve clearance.*

1. To install, reverse the removal procedure.
2. **NOTE:** *Make sure that the mating faces are clean and free of foreign material.*

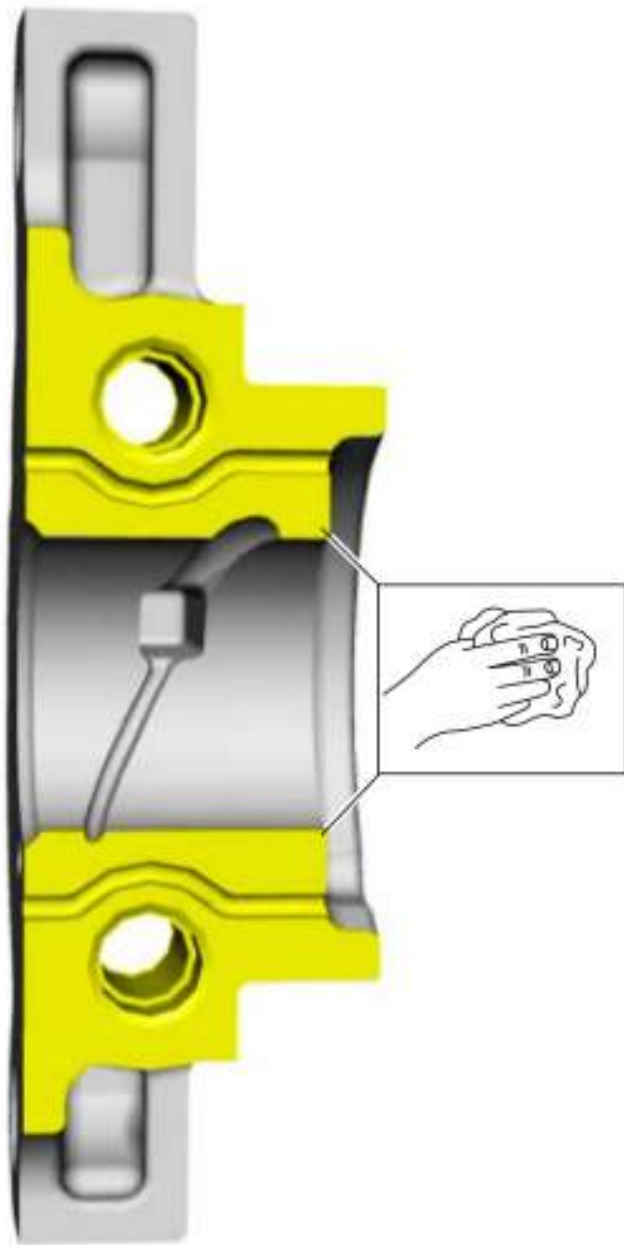

N0152528



3. **NOTE:** *The component must be installed within 10 minutes of applying the sealant.*

*Material:* Flange Sealant / CU7Z-19B508-A (WSS-M2G348-A11)

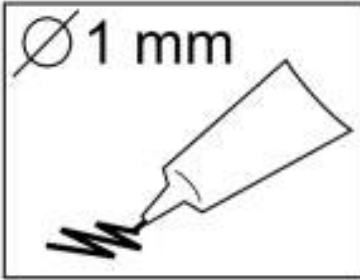

N0152415

1. **NOTE:** Make sure that the components are installed to the position noted before removal.

Install the camshafts approximately at valve overlap position cylinder No. 4.

2. **NOTE:** Component(s) must be lubricated with clean engine oil.

Tighten each bolt 2 turns at a time.

*Torque:*

Stage 1: 62 lb.in (7 Nm)

Stage 2: 142 lb.in (16 Nm)

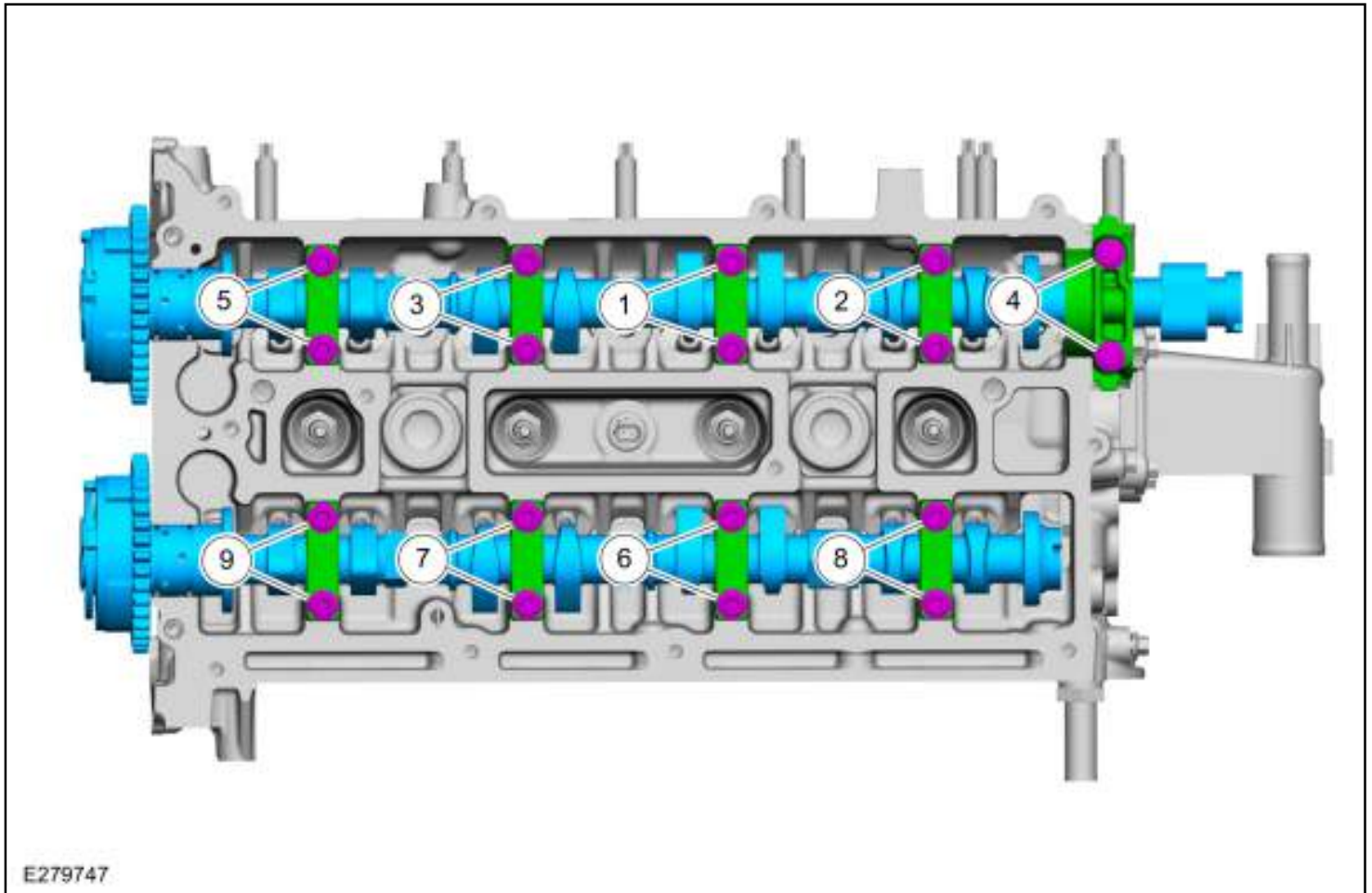

5. **NOTE:** Component(s) must be lubricated with clean engine oil.

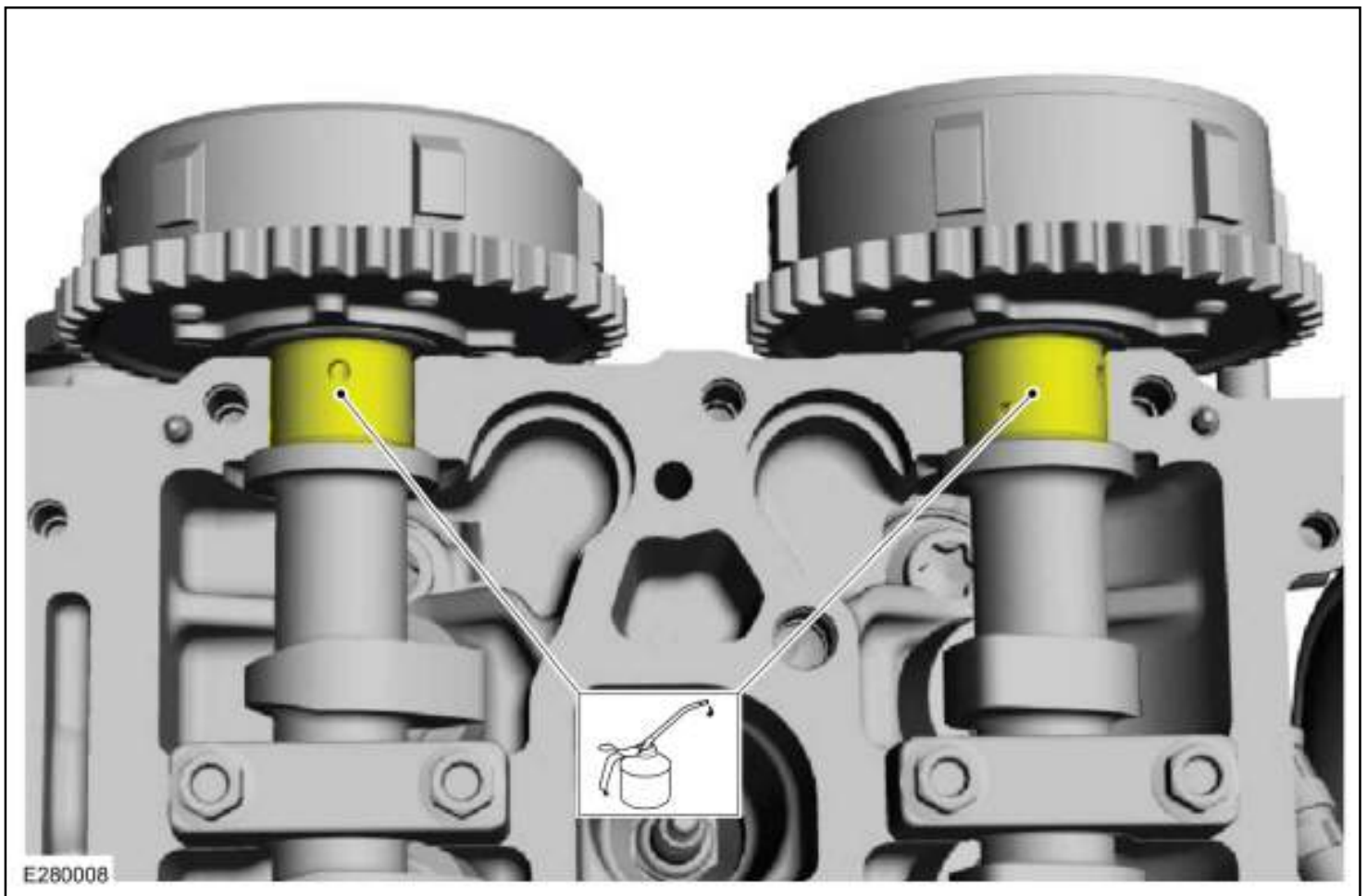

6. Tighten each bolt 2 turns at a time.

*Torque:*

Stage 1: 62 lb.in (7 Nm)

Stage 2: 142 lb.in (16 Nm)



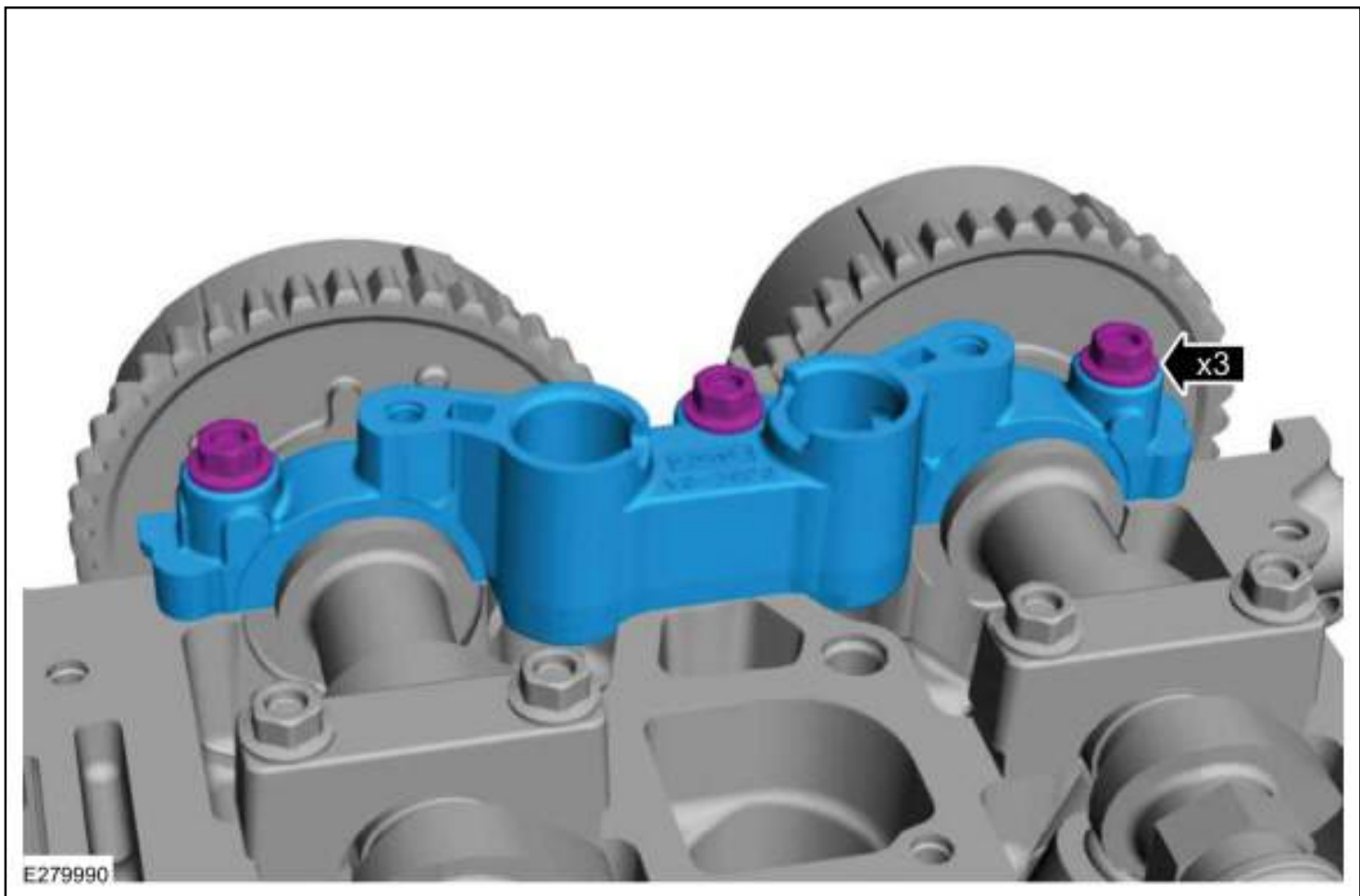

7. **NOTE:** *If any new parts are being installed (cylinder head, valves, tappets, camshafts) it is necessary to check the valve clearance. If the original parts are being installed it is not necessary to check the valve clearance.*

Refer to: [Valve Clearance Adjustment](#) (303-01C Engine, General Procedures).

8. **NOTE:** *Make sure that the components are installed to the position noted before removal.*

*Torque: 89 lb.in (10 Nm)*

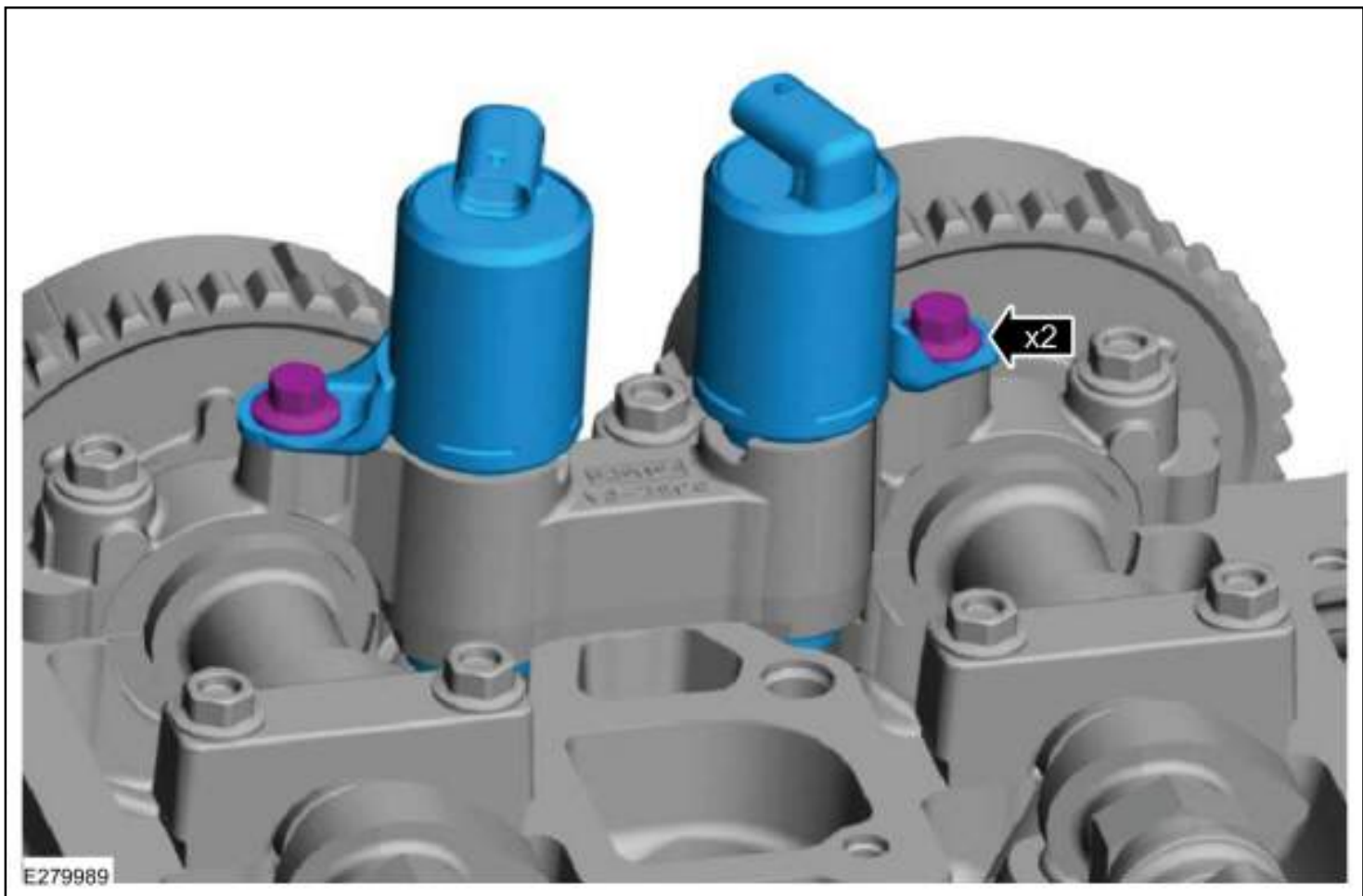

9. Install Special Service Tool: 303-1565 Alignment Tool, Camshaft.

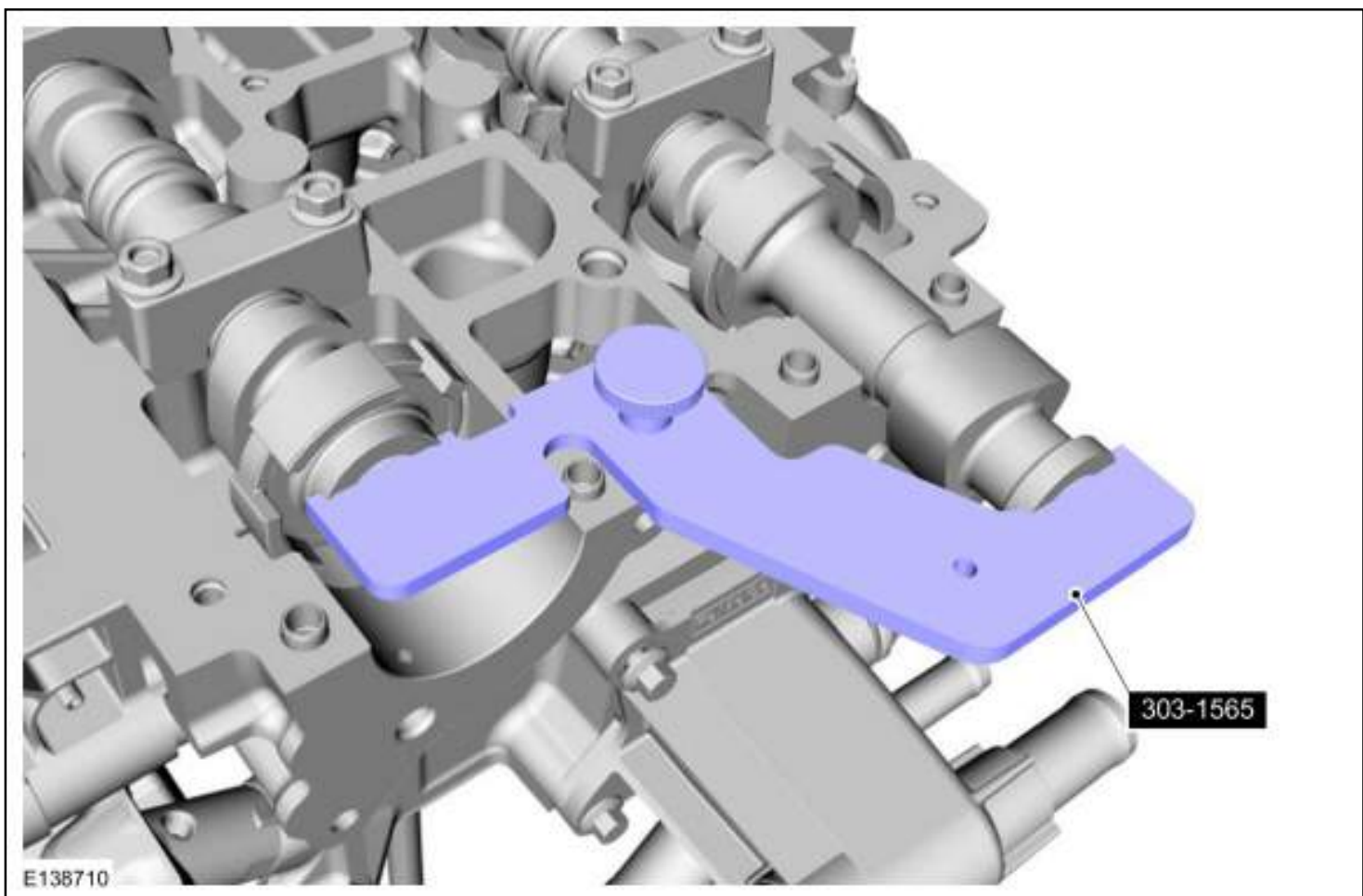

10. **NOTE:** *This step is only necessary if the camshafts are being serviced.*

Refer to: [Variable Camshaft Timing \(VCT\) Unit](#) (303-01C Engine, Removal and Installation).

11. Refer to: [Timing Chain](#) (303-01C Engine, Removal and Installation).

Copyright © 2019 Ford Motor Company

---

## Variable Camshaft Timing (VCT) Unit

### Special Tool(s) / General Equipment



### Removal

1. Refer to: [Timing Chain](#) (303-01C Engine, Removal and Installation).
2. **NOTICE:** Use an open-ended wrench to prevent the component from turning.

**NOTE:** Discard the bolts.

**NOTE:** Note the position of the components before removal.

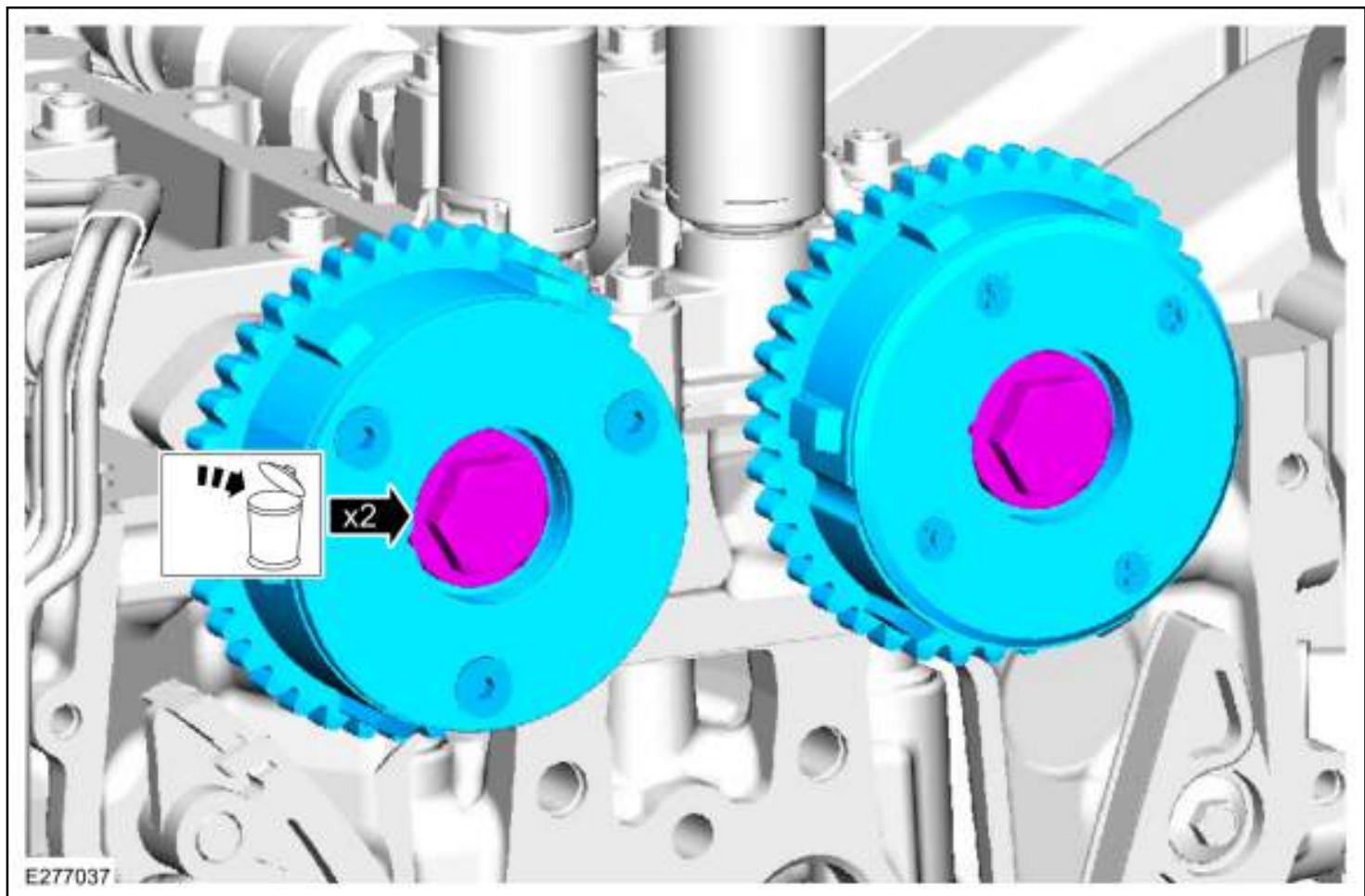

3. If equipped.

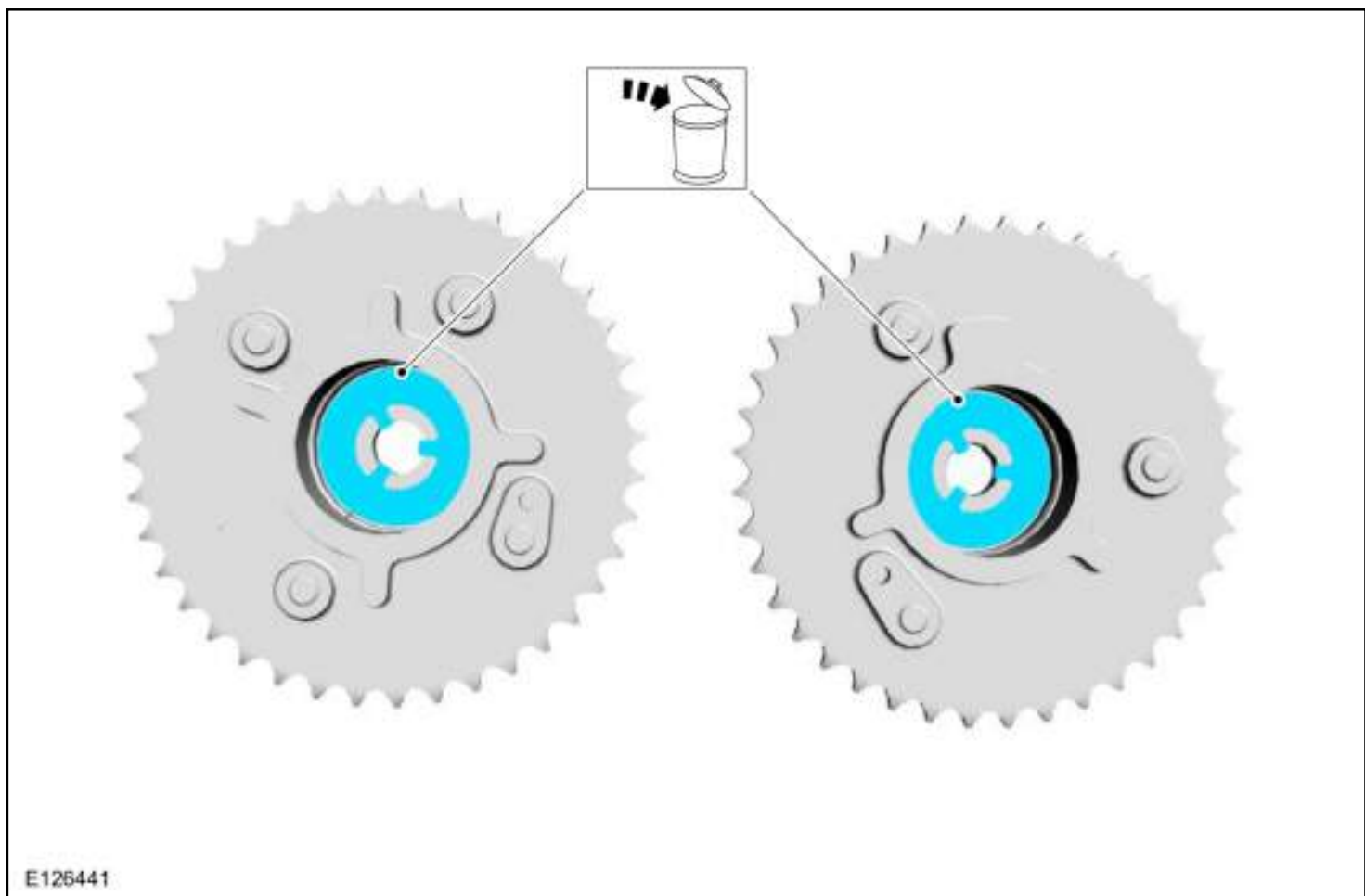

## Installation

1. **NOTE:** *Make sure that the components are installed to the position noted before removal.*

**NOTE:** *Make sure that new bolts are installed.*

**NOTE:** *Only tighten the bolts finger tight at this stage.*

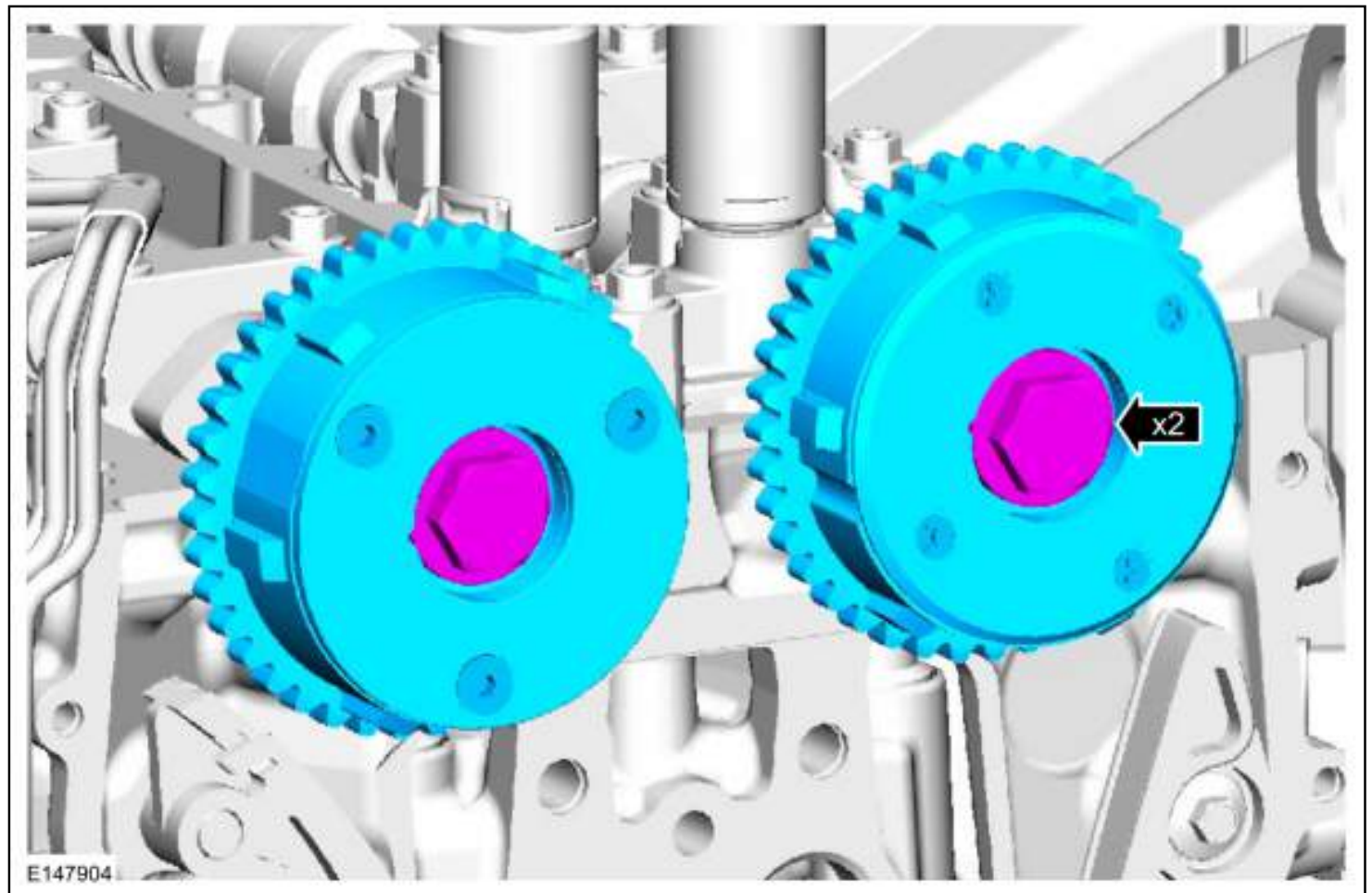

2. **⚠️ WARNING:** **The tensioner is under spring tension. Be careful when handling the tensioner. Failure to follow this instruction may result in personal injury.**

*Torque: 89 lb.in (10 Nm)*

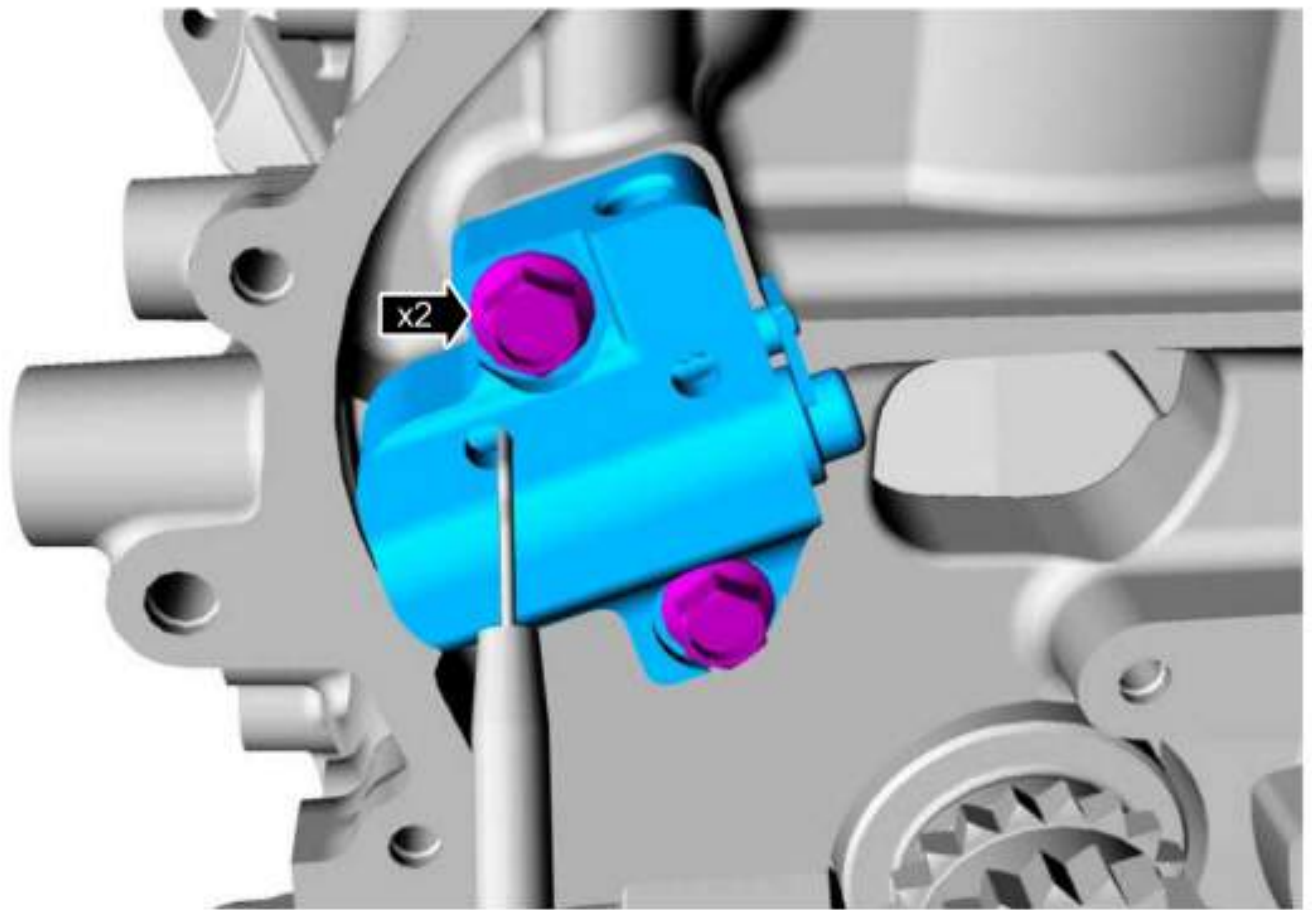

E136841

3. *Torque:* 89 lb.in (10 Nm)

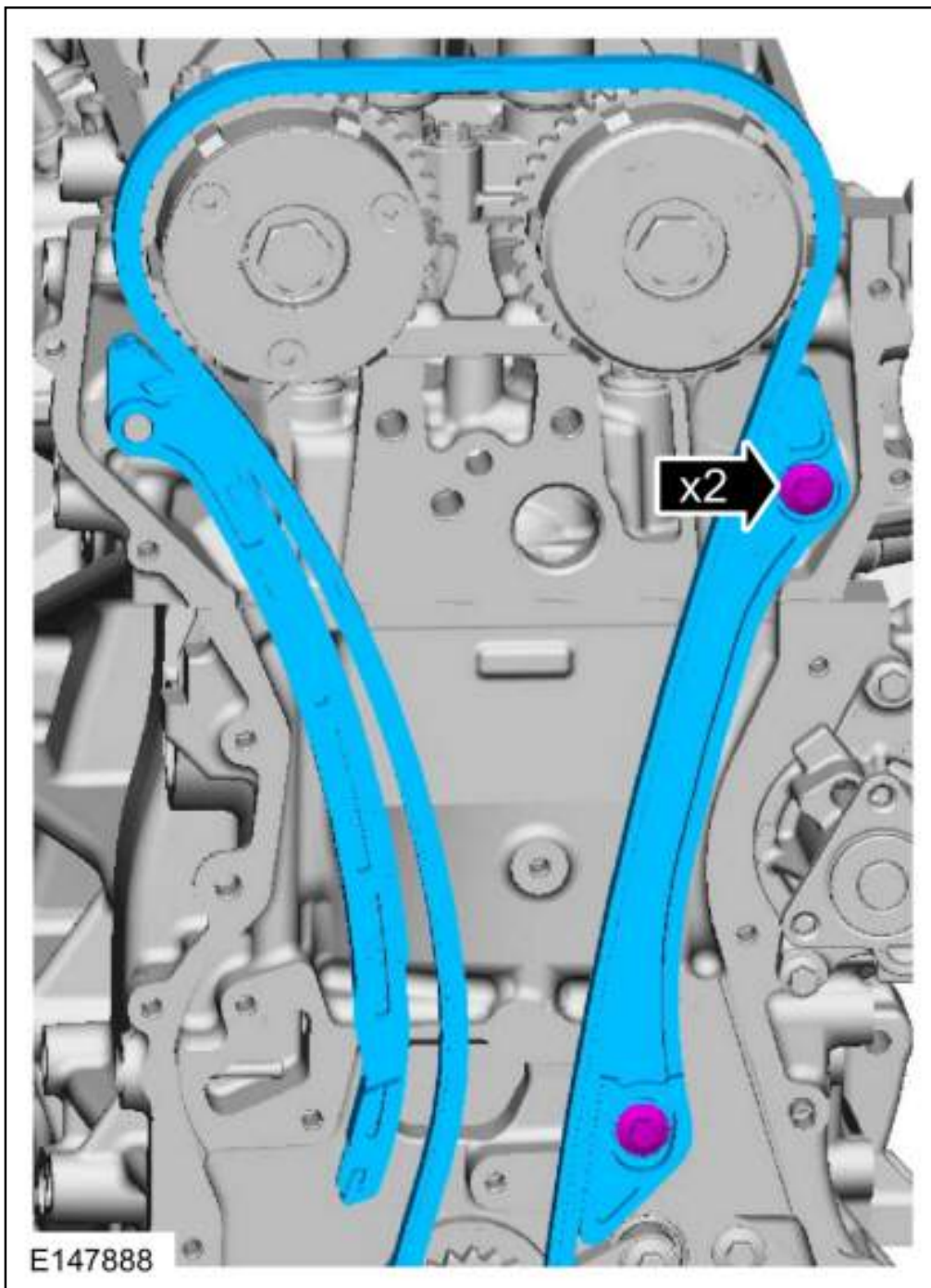

- 4.  **WARNING: The tensioner is under spring tension. Be careful when handling the tensioner. Failure to follow this instruction may result in personal injury.**

Remove Special Service Tool: 100-010 Remover, O-Ring Seal.

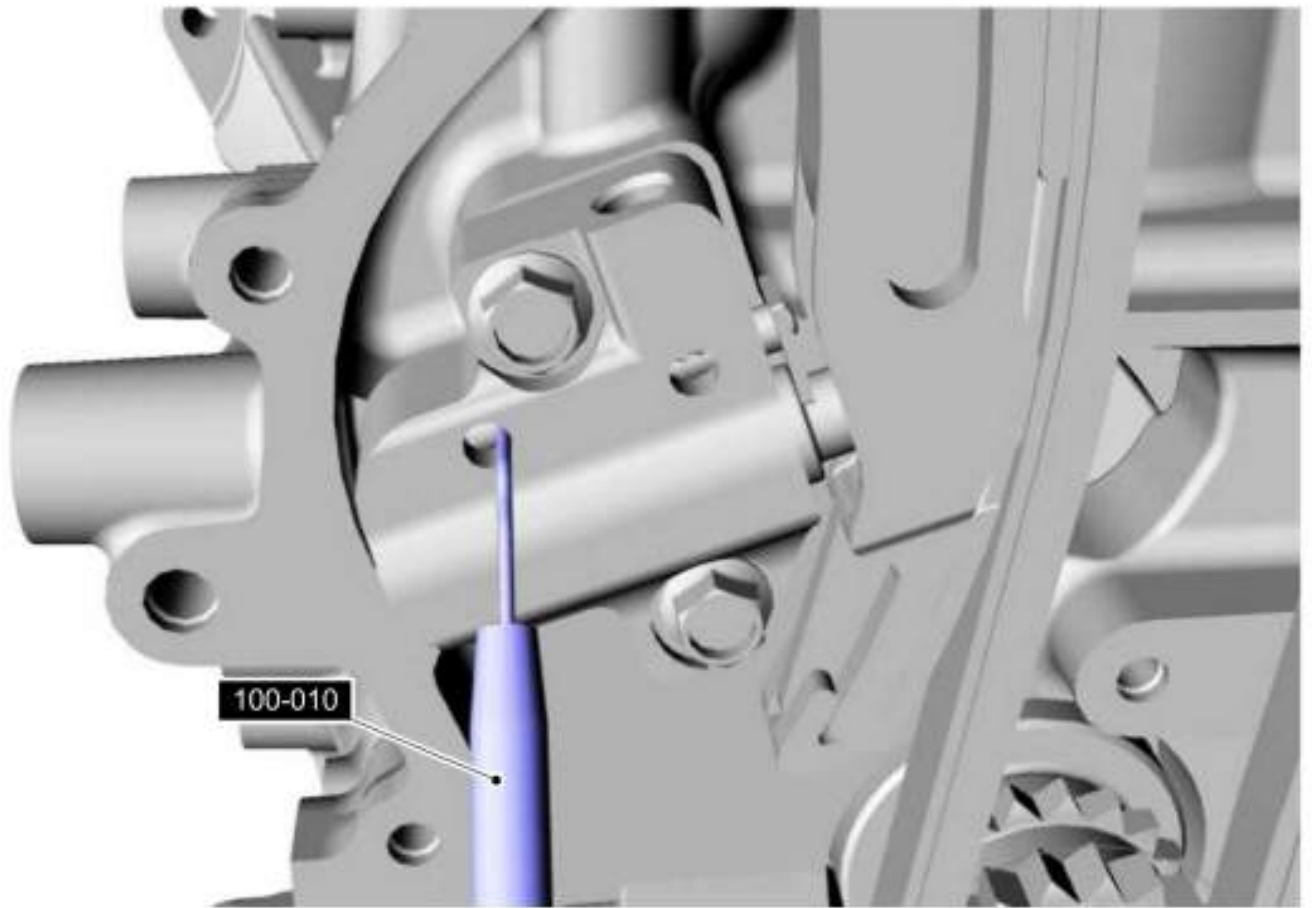

5. **NOTICE:** Use an open-ended wrench to prevent the component from turning.

*Torque:*

Stage 1: 30 lb.ft (40 Nm)

Stage 2: 90°



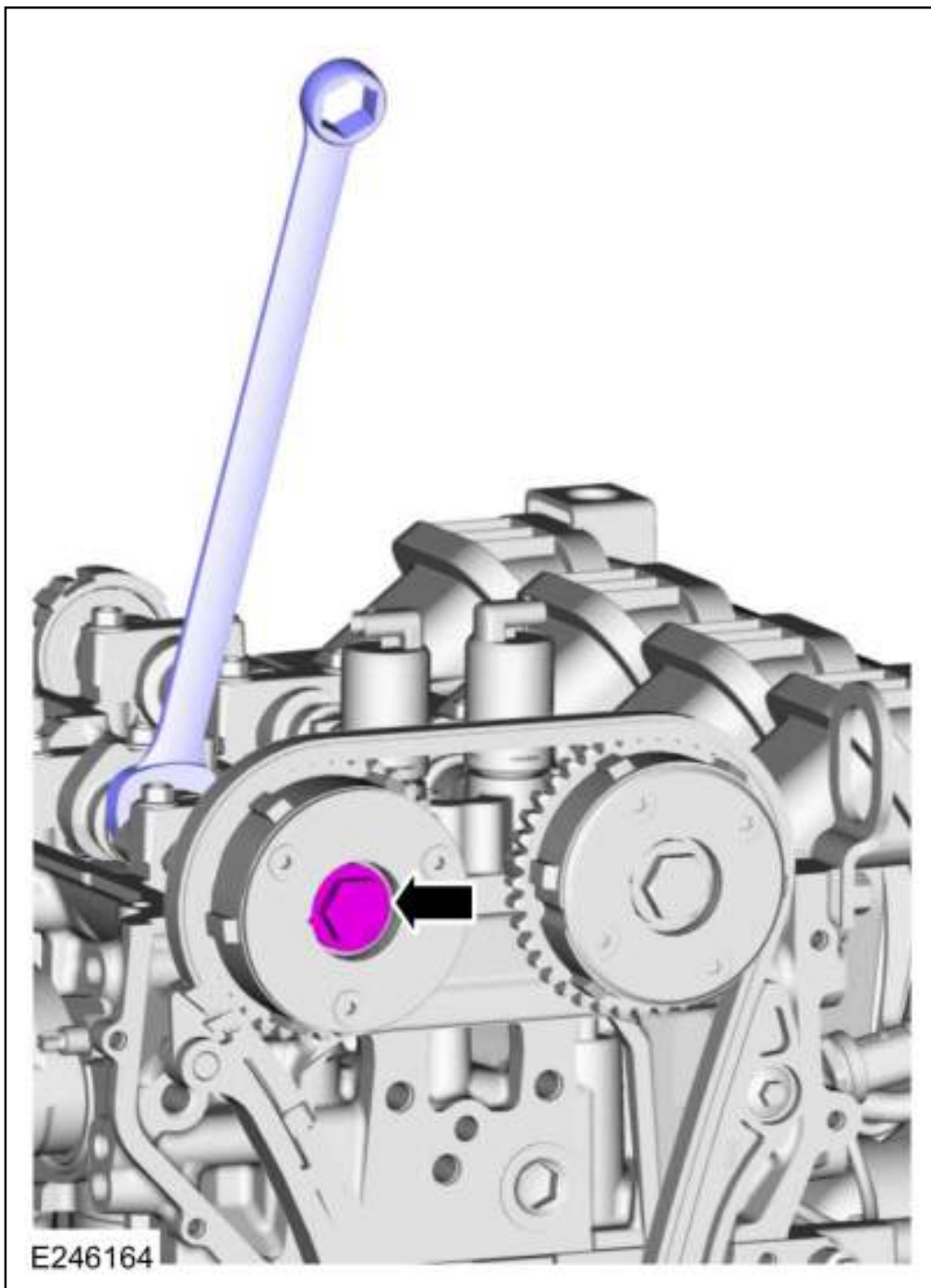

6. **NOTICE:** Use an open-ended wrench to prevent the component from turning.

*Torque:*

Stage 1: 30 lb.ft (40 Nm)

Stage 2: 90°

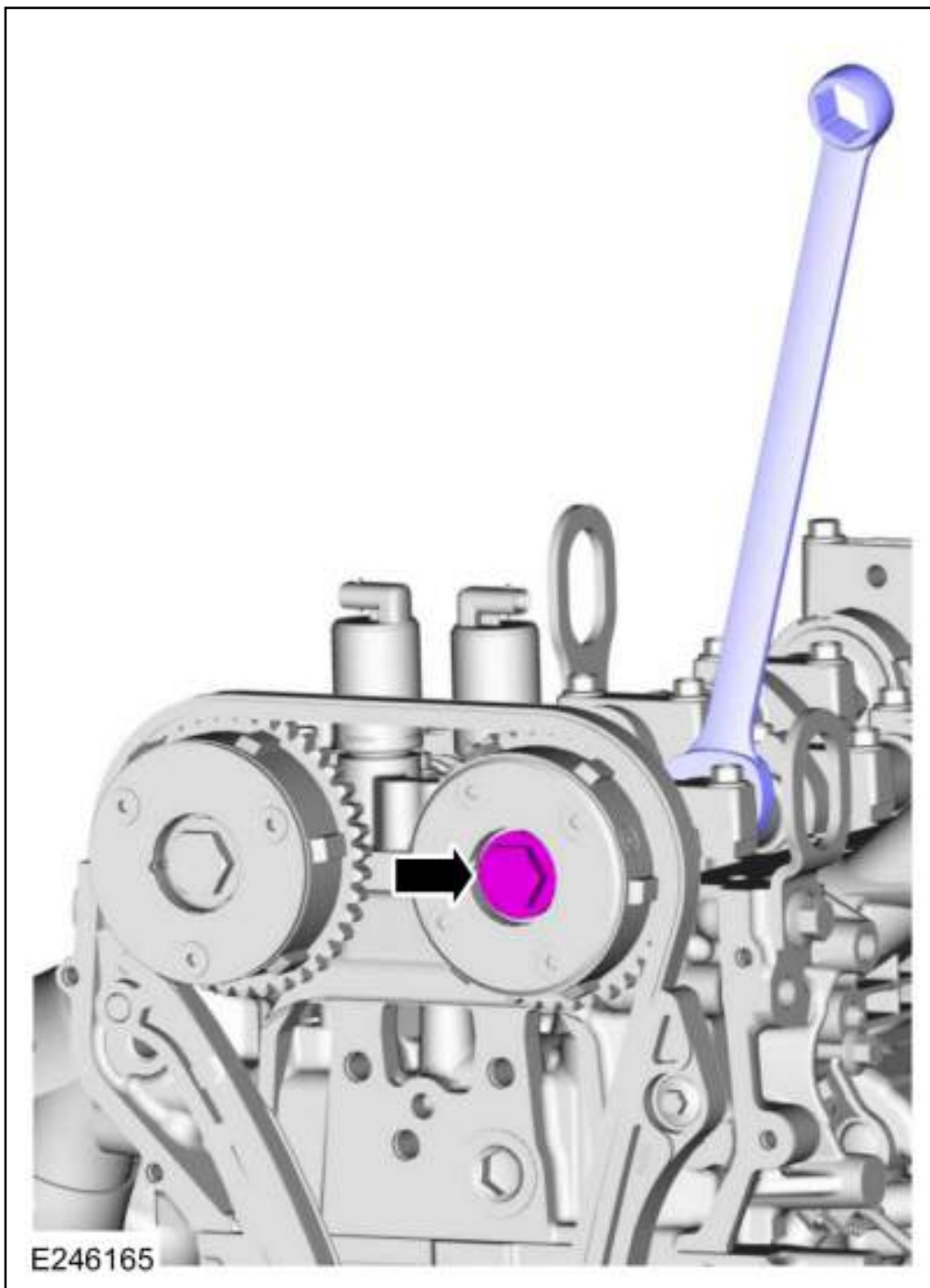

7. Install the following items:

1. Refer to: [Engine Front Cover](#) (303-01C Engine, Removal and Installation).
2. Refer to: High-Pressure Fuel Pump Drive Unit (303-04 Fuel Charging and Controls - 2.3L EcoBoost (257kW/350PS) - MI4) .



## Timing Chain

### Special Tool(s) / General Equipment

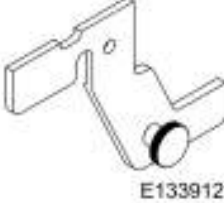
 17063	100-010 Remover, O-Ring Seal
 E133912	303-1565 Alignment Tool, Camshaft TKIT-2010C-FLM
2 mm Punch	

### Removal

1. Remove the following items:
  1. Refer to: [Engine Front Cover](#) (303-01C Engine, Removal and Installation).
  2. Refer to: High-Pressure Fuel Pump Drive Unit (303-04G) .
2. Remove Special Service Tool: 303-1565 Alignment Tool, Camshaft.

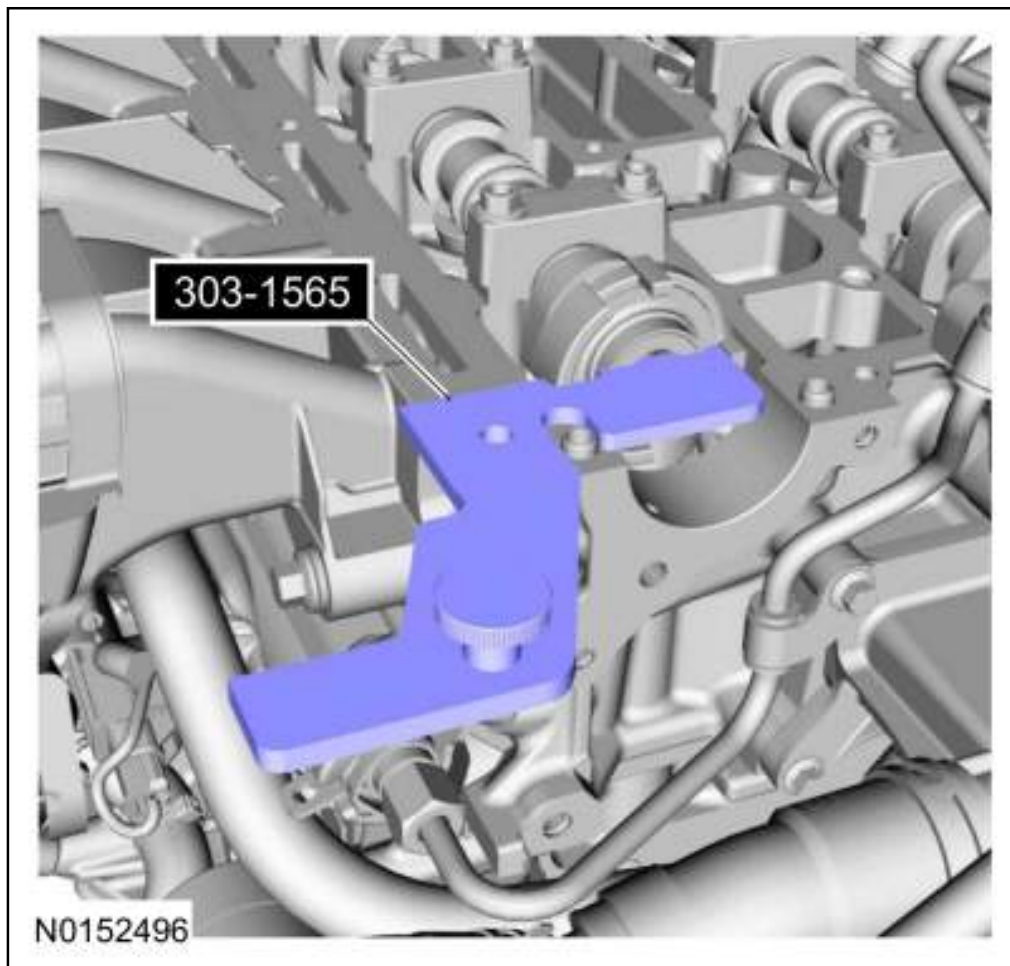

3. Install Special Service Tool: 303-1565 Alignment Tool, Camshaft.

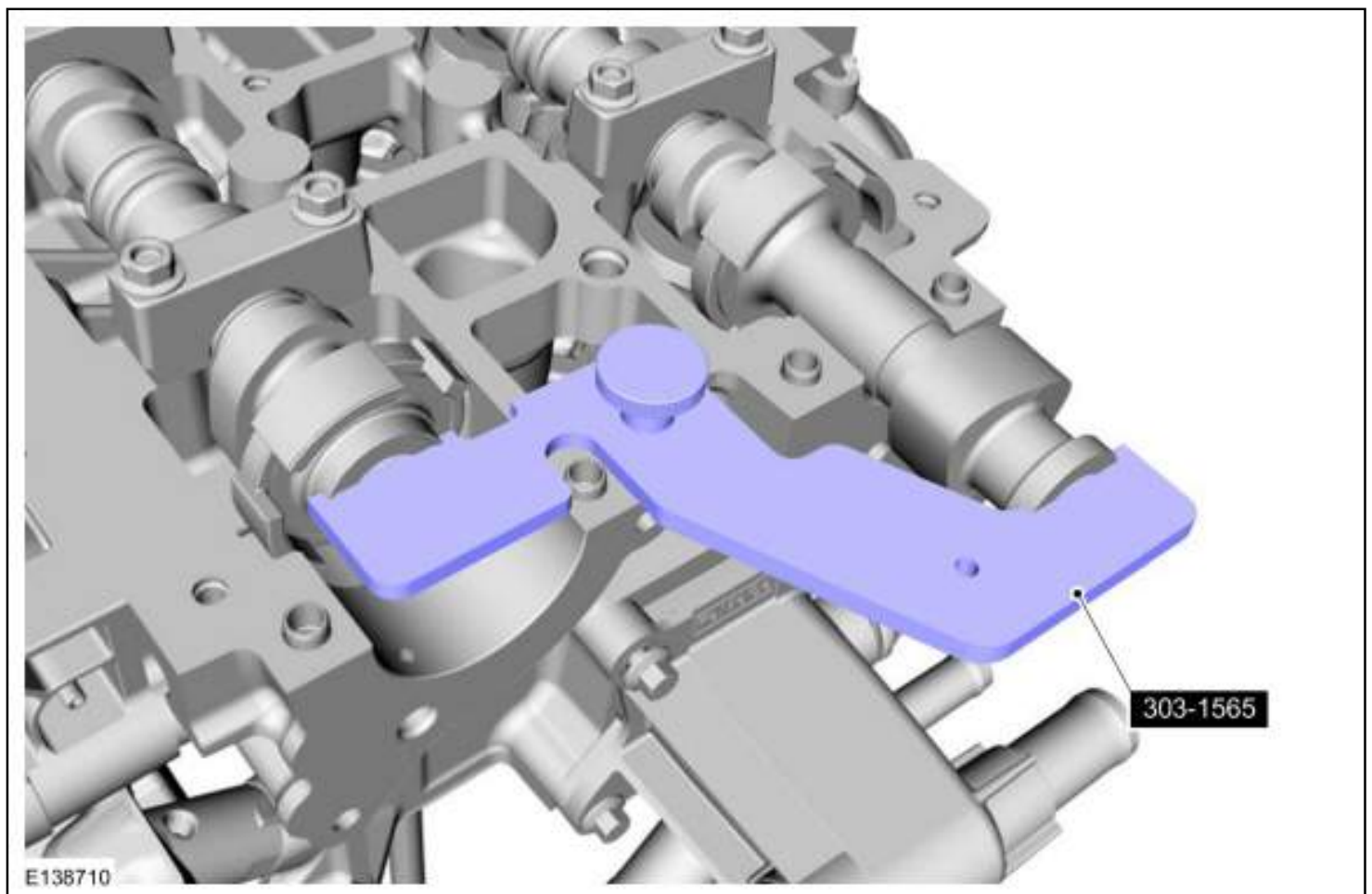

4. Install Special Service Tool: 100-010 Remover, O-Ring Seal.  
Use the General Equipment: 2 mm Punch

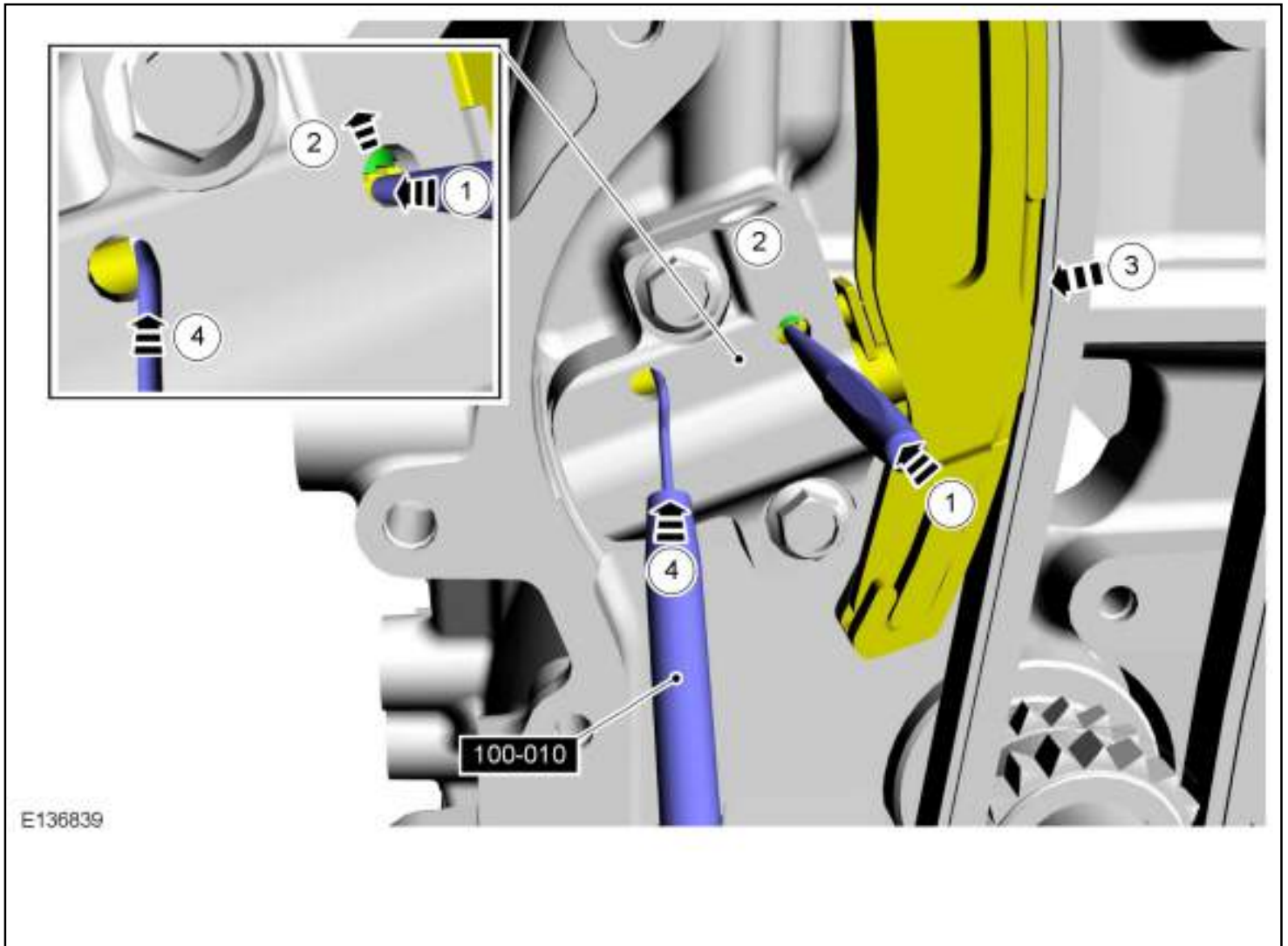

- 5.

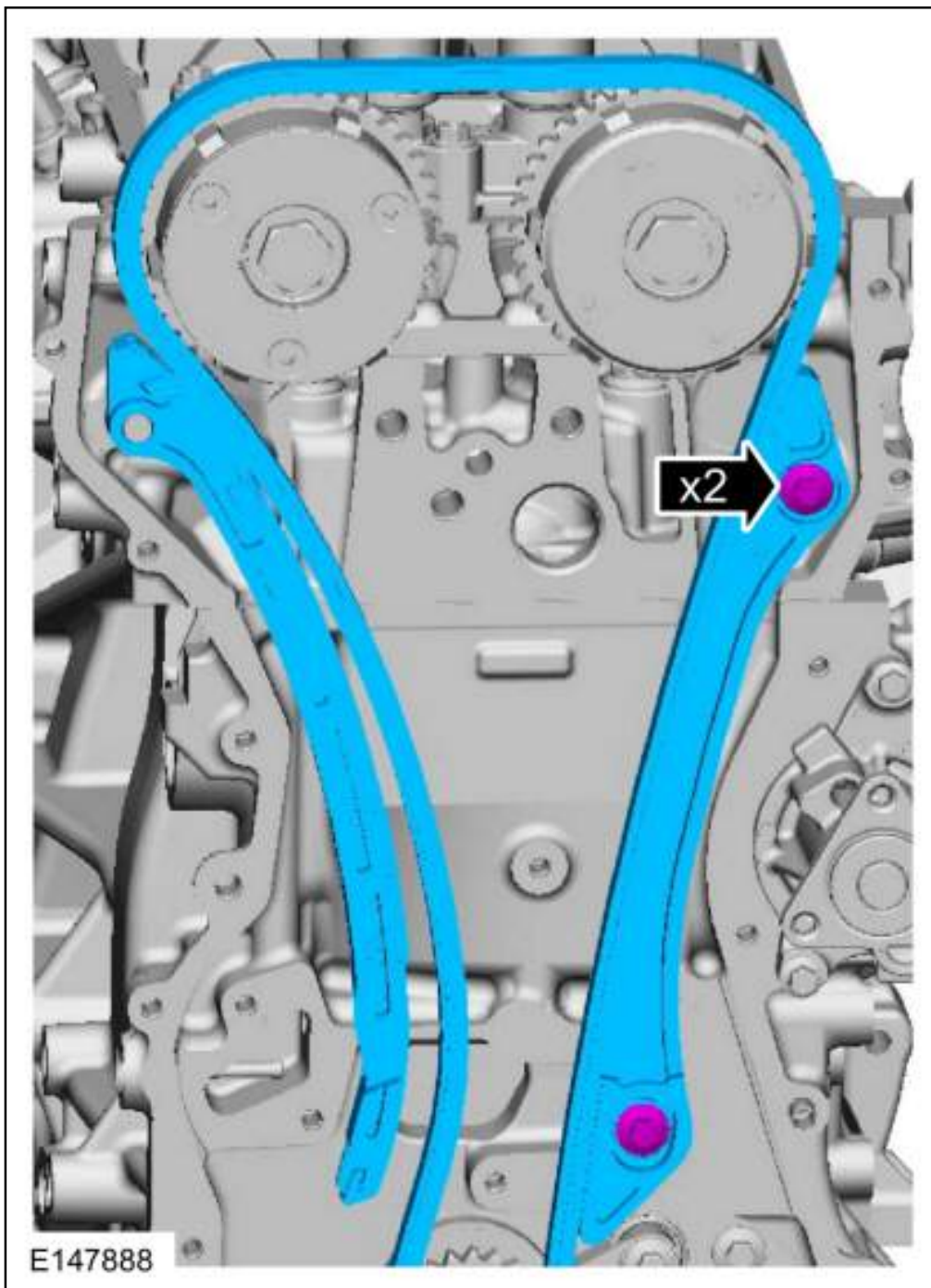

6.  **WARNING:** The tensioner is under spring tension. Be careful when handling the tensioner. Failure to follow this instruction may result in personal injury.

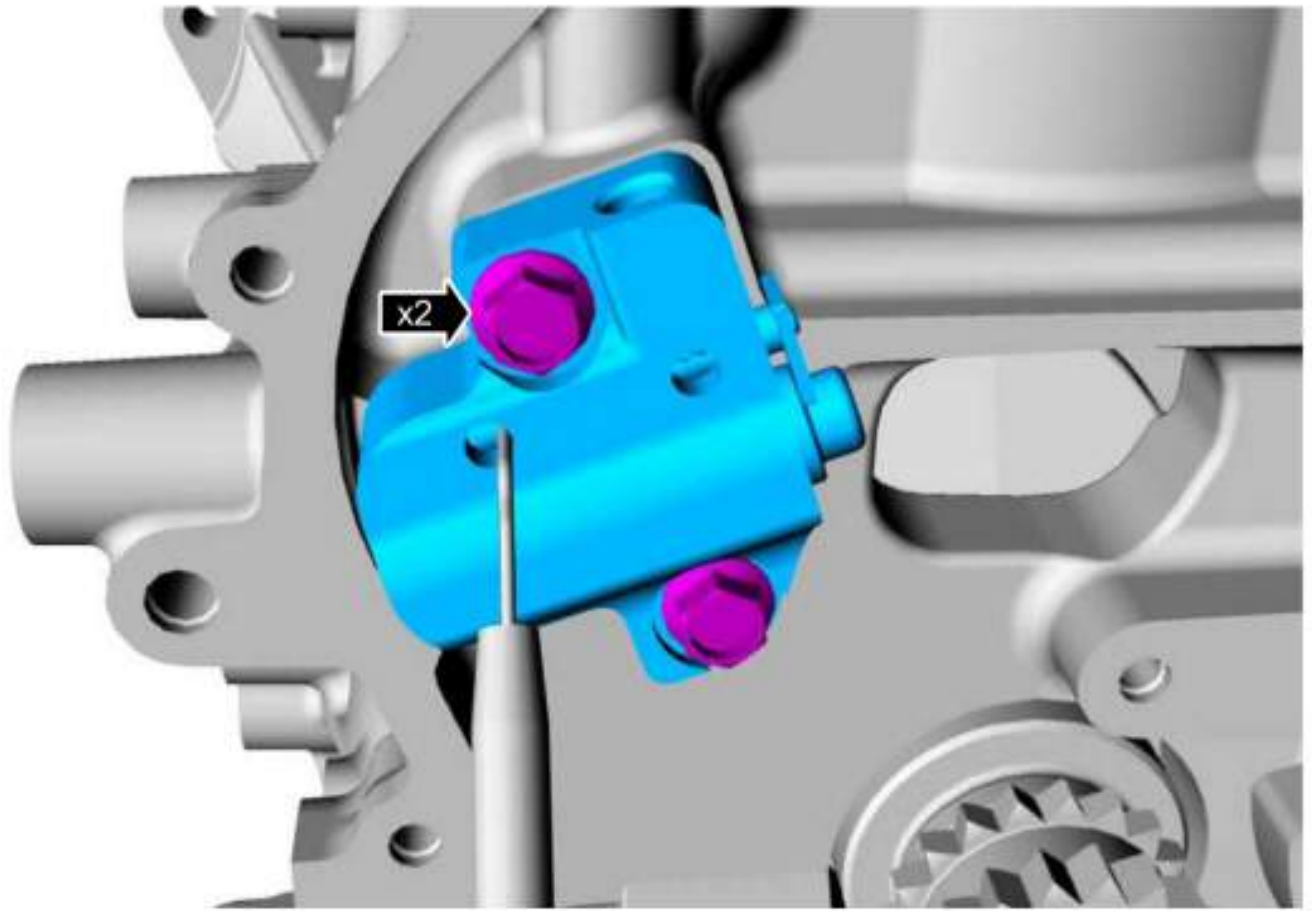

E136841



carcagn.

## Installation

1.  **WARNING:** The tensioner is under spring tension. Be careful when handling the tensioner. Failure to follow this instruction may result in personal injury.

*Torque:* 89 lb.in (10 Nm)

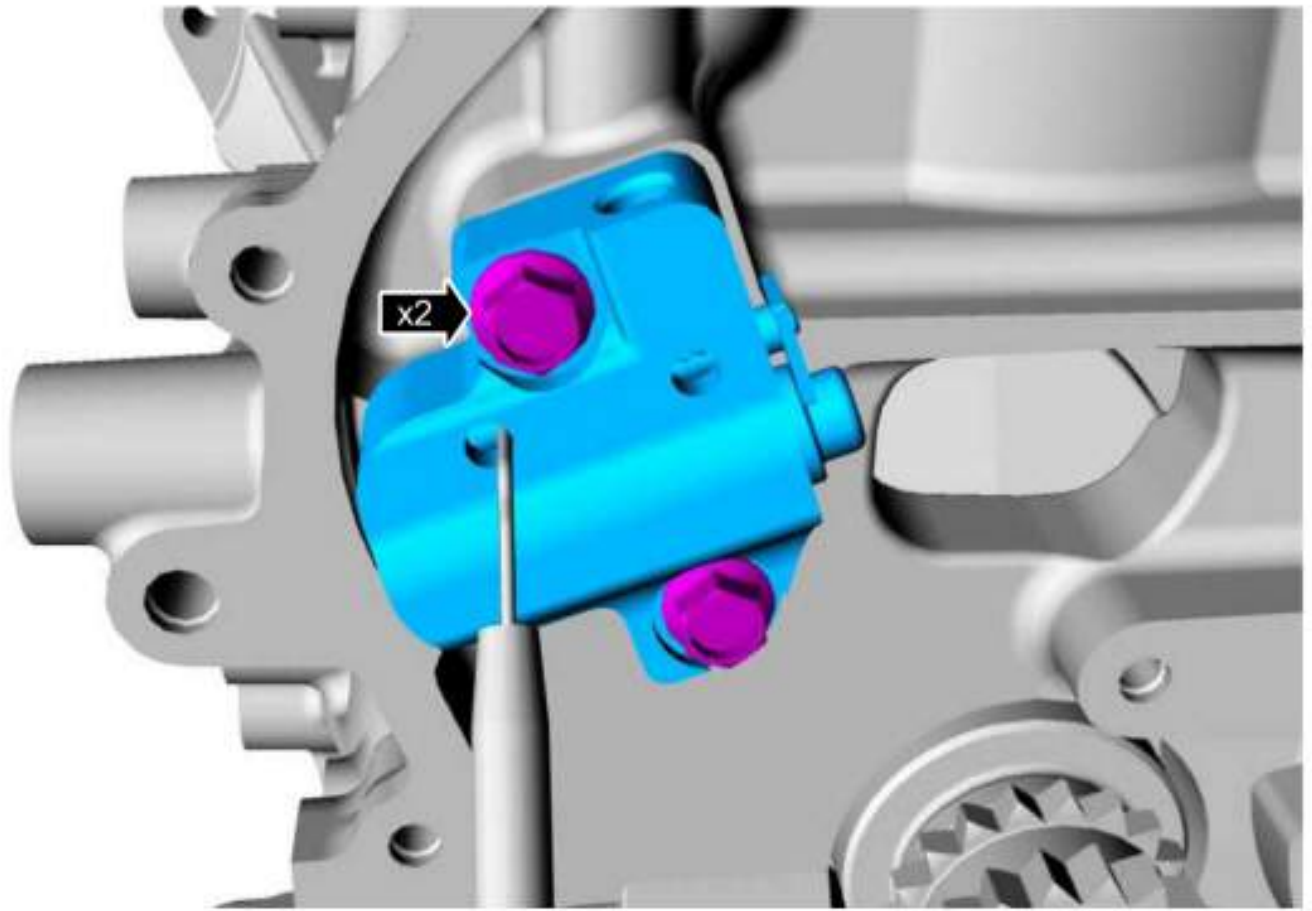

E136841

2. *Torque:* 89 lb.in (10 Nm)

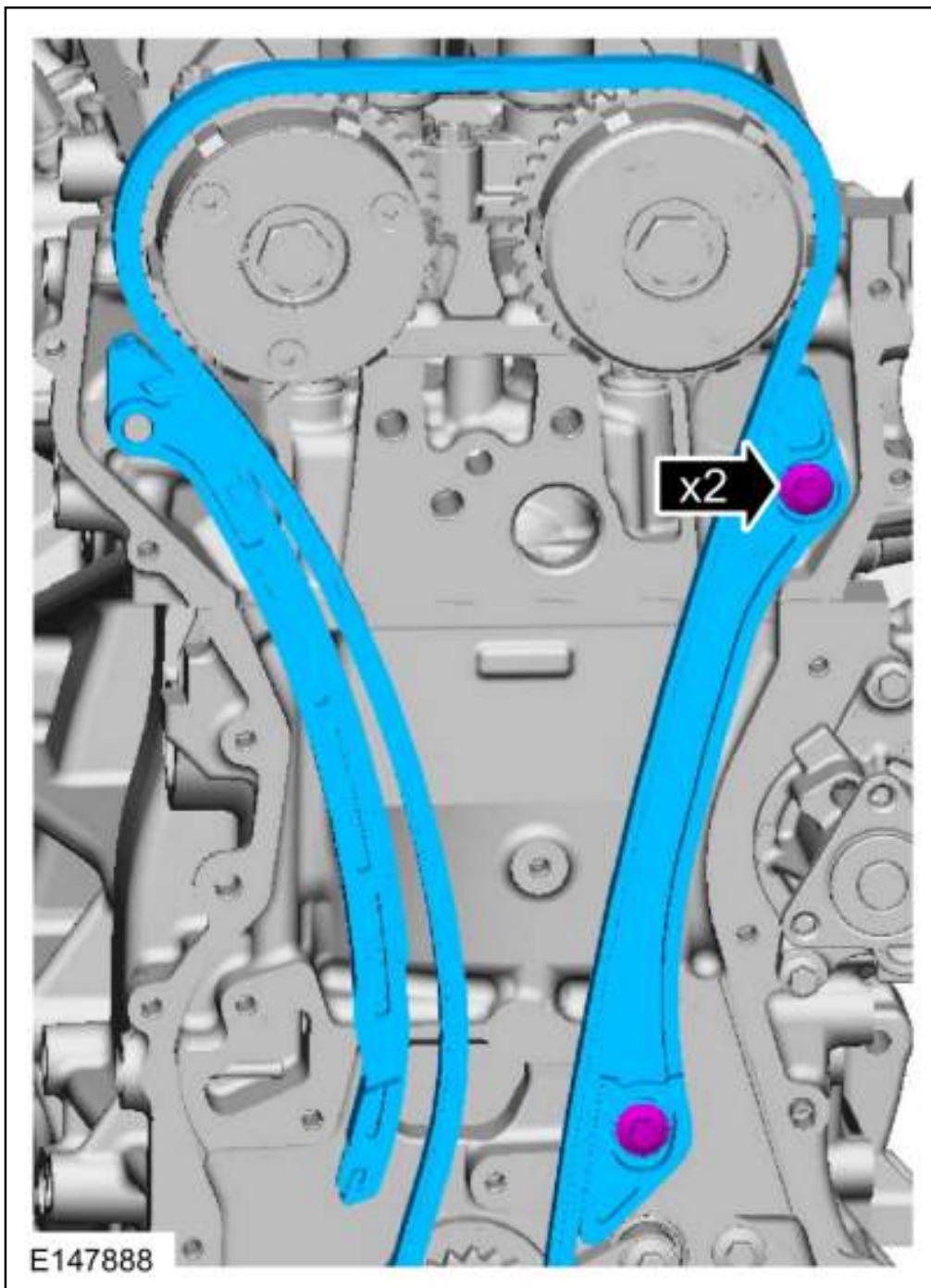

3.  **WARNING: The tensioner is under spring tension. Be careful when handling the tensioner. Failure to follow this instruction may result in personal injury.**

Remove Special Service Tool: 100-010 Remover, O-Ring Seal.

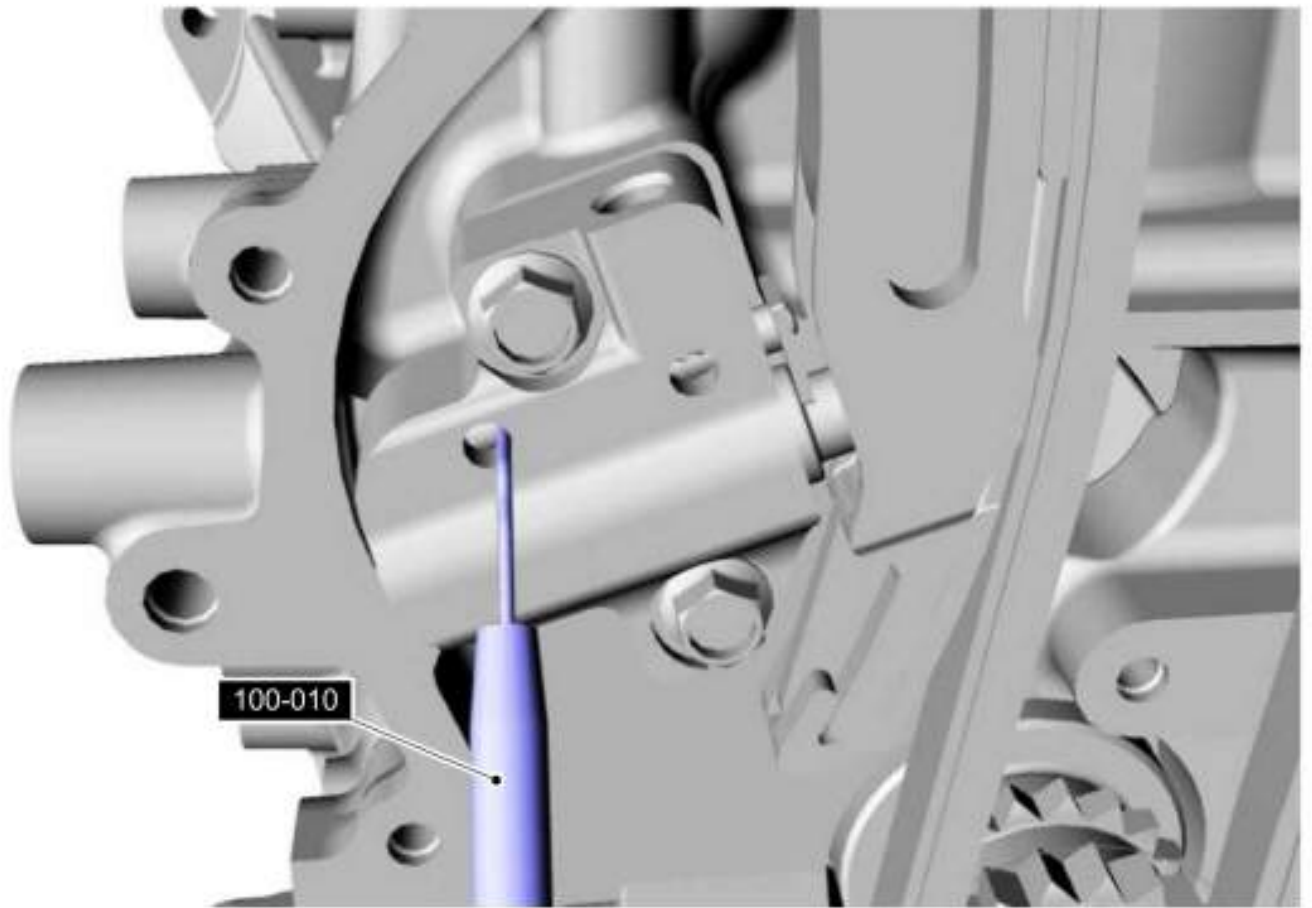

E136842



4. Install the following items:

1. Refer to: [Engine Front Cover](#) (303-01C Engine, Removal and Installation).
2. Refer to: High-Pressure Fuel Pump Drive Unit (303-04G) .



# Engine Front Cover

Base Part Number: Base Part Number: 6C086

## Special Tool(s) / General Equipment

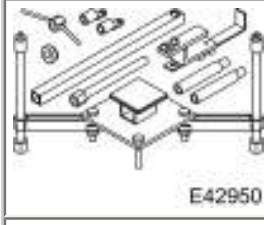
	303-1554 Engine Support Bar
	303-290A-15 Adapter for 303-290A
Plastic Scraper	

## Materials

Name	Specification
Motorcraft® High Performance Engine RTV Silicone TA-357	WSE-M4G323-A6
Motorcraft® Metal Surface Prep Wipes ZC-31-B	-

## Removal

**NOTE:** Removal steps in this procedure may contain installation details.

1. Refer to: [Crankshaft Front Seal](#) (303-01C Engine, Removal and Installation).
- 2.

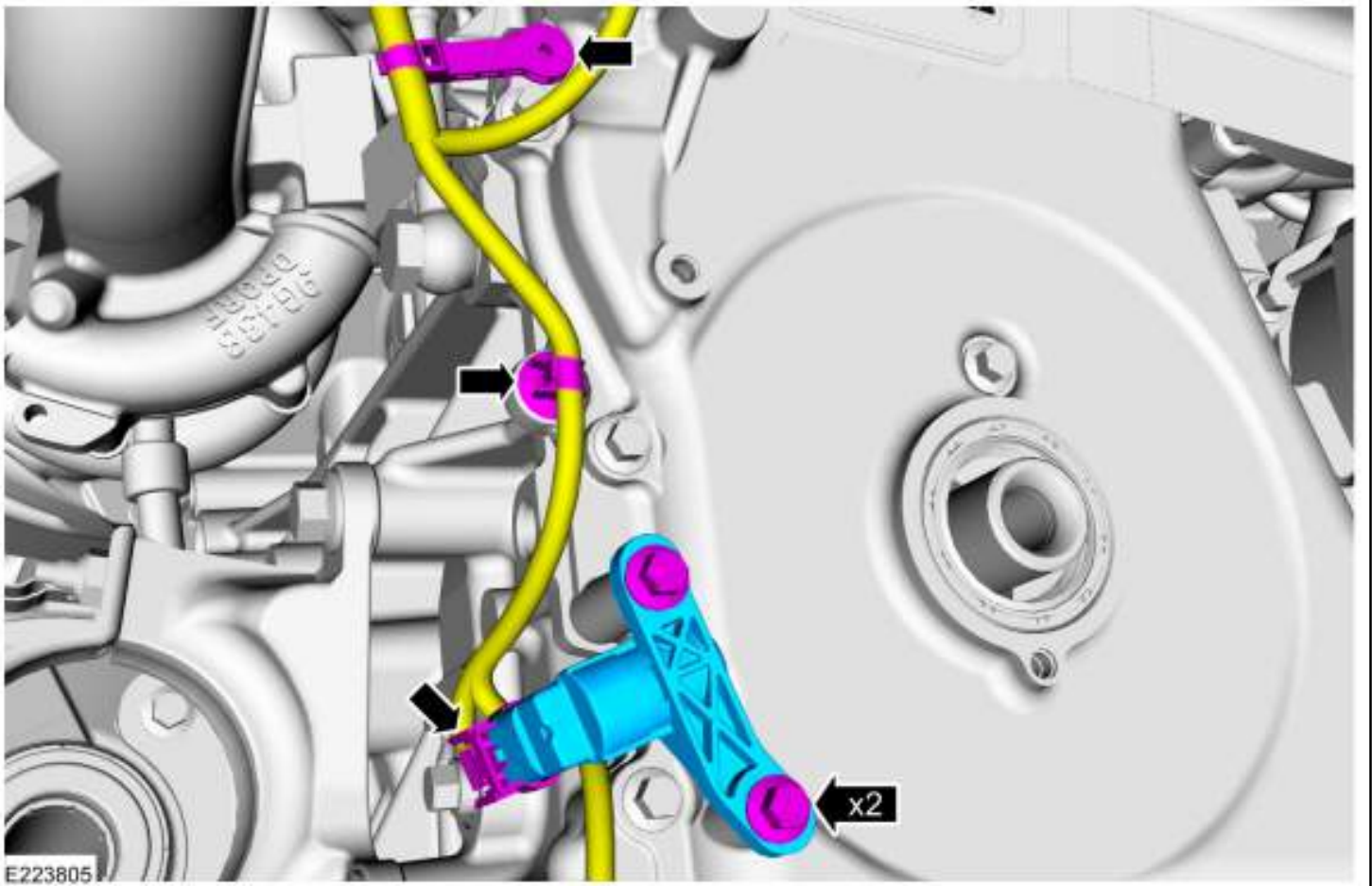

3.

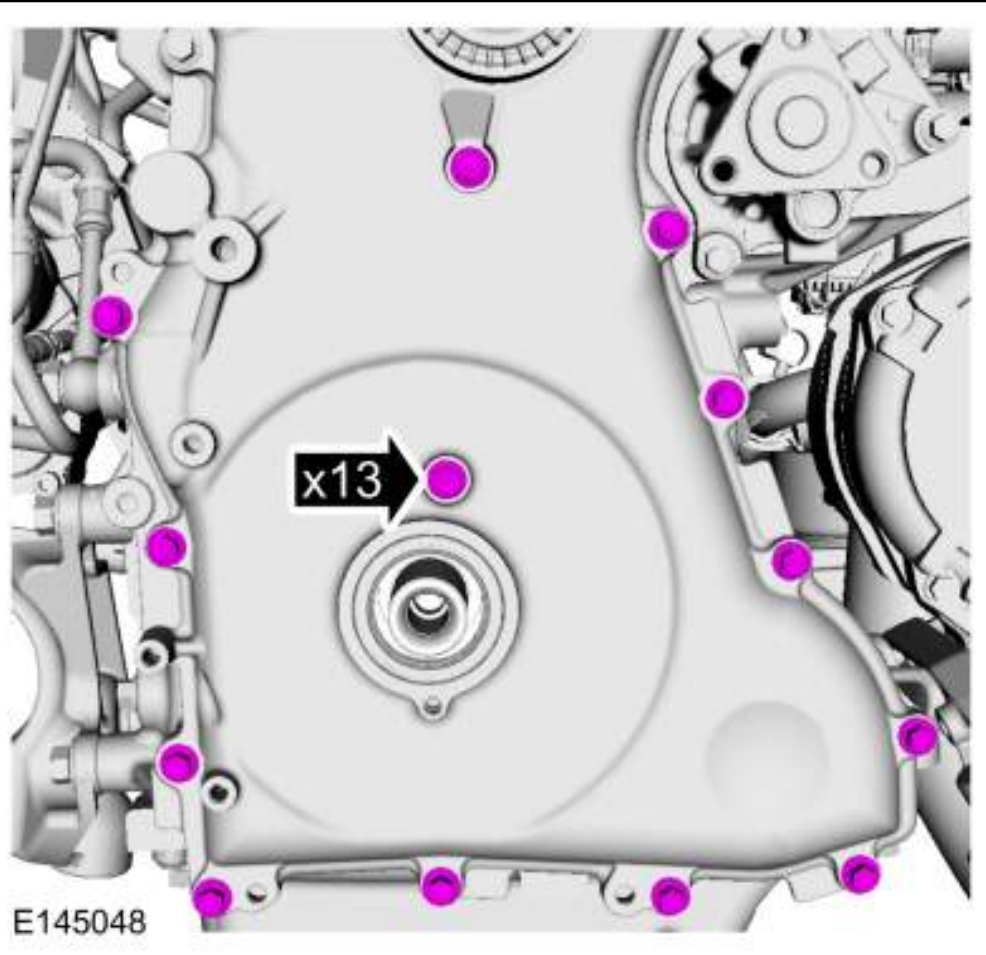

1. *Torque:* 89 lb.in (10 Nm)
2. *Torque:* 27 lb.in (3 Nm)

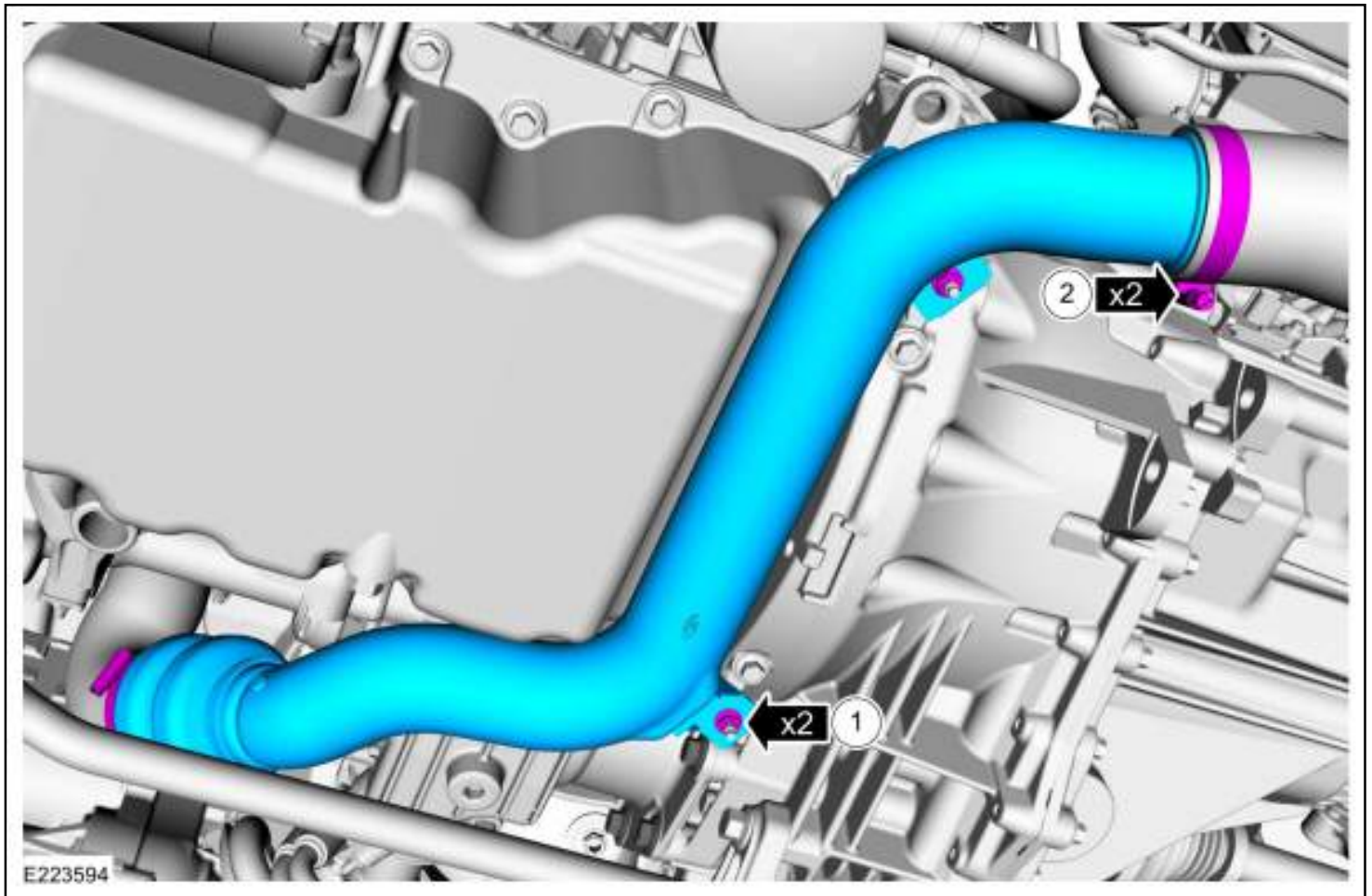

5. Install Special Service Tool: 303-1554 Engine Support Bar. , 303-290A-15 Adapter for 303-290A.

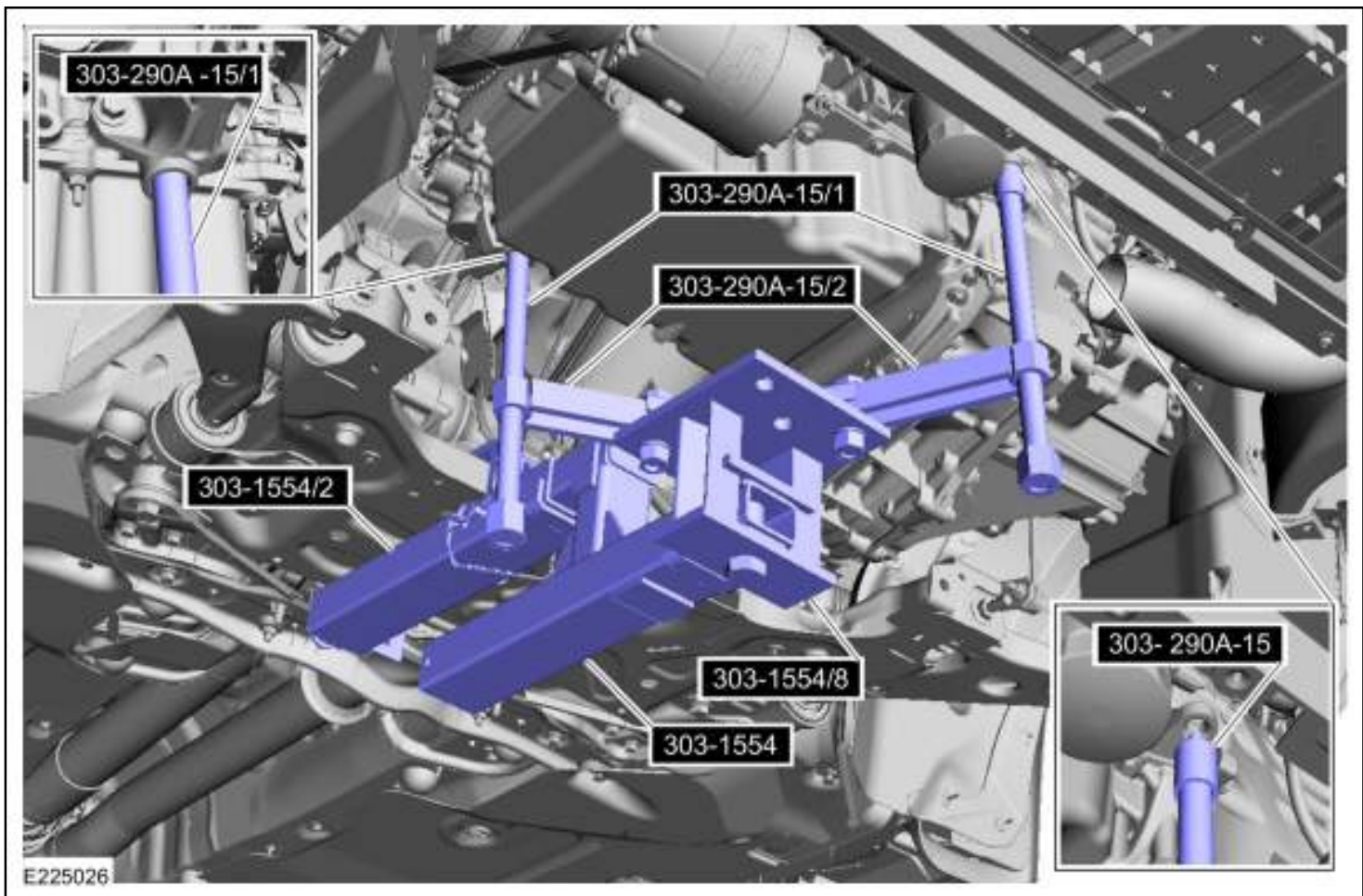

6.

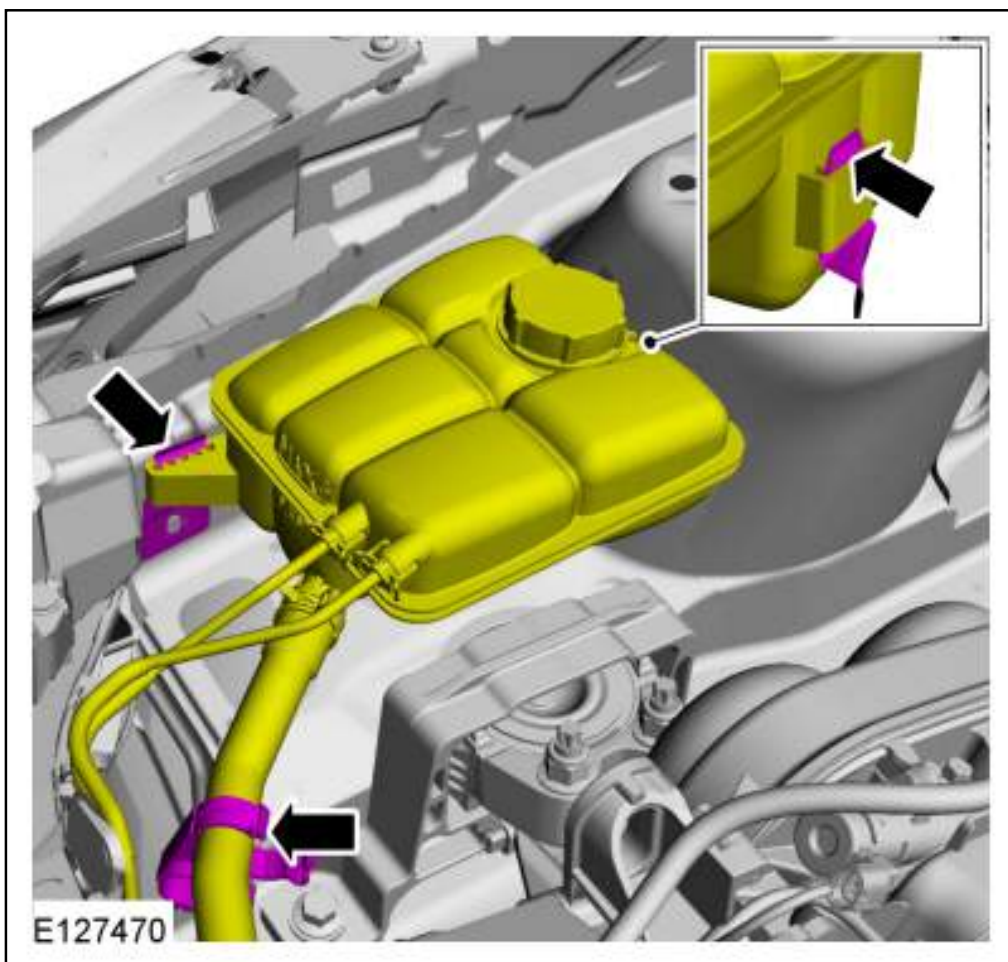

7.

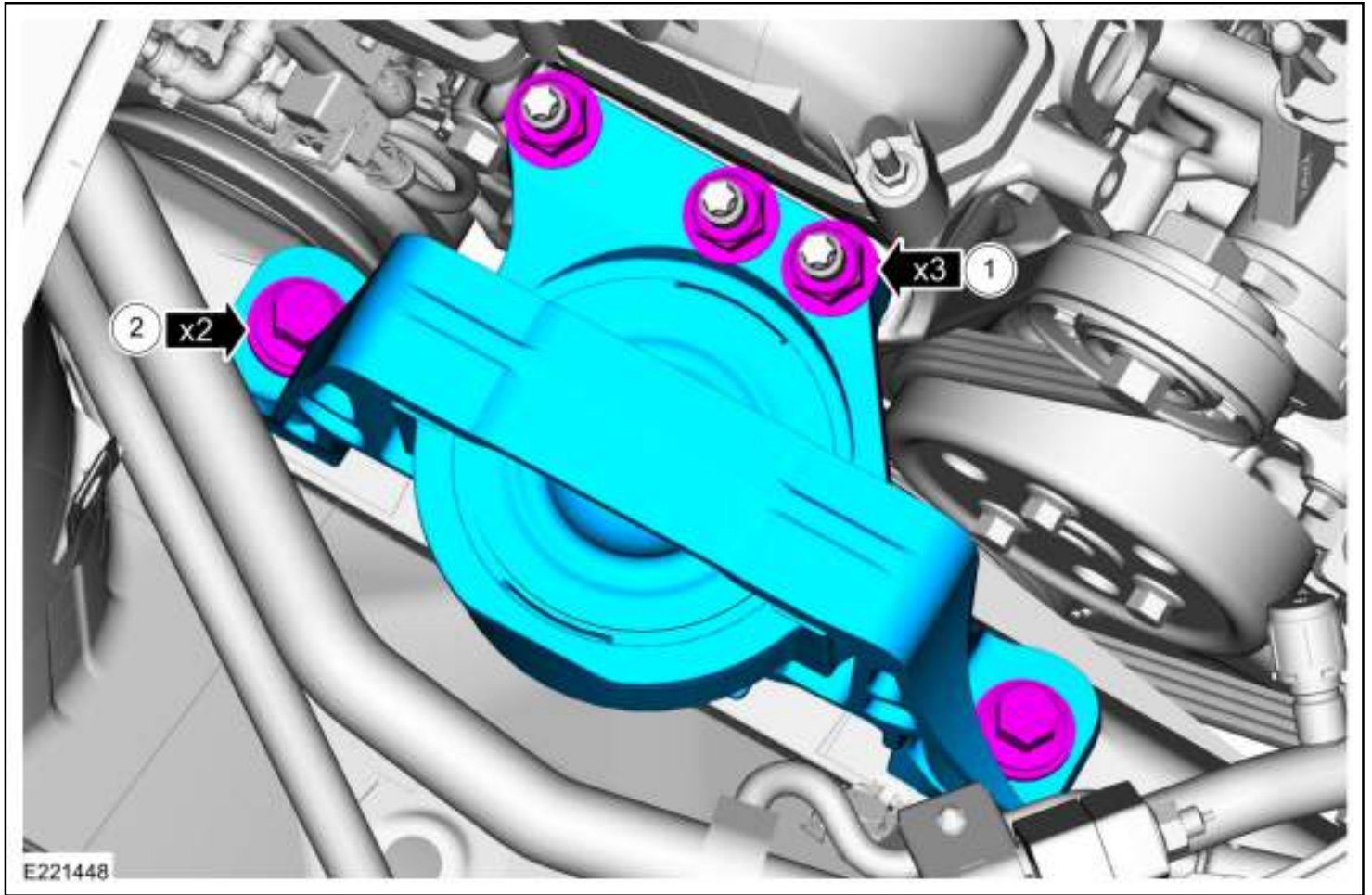

8.

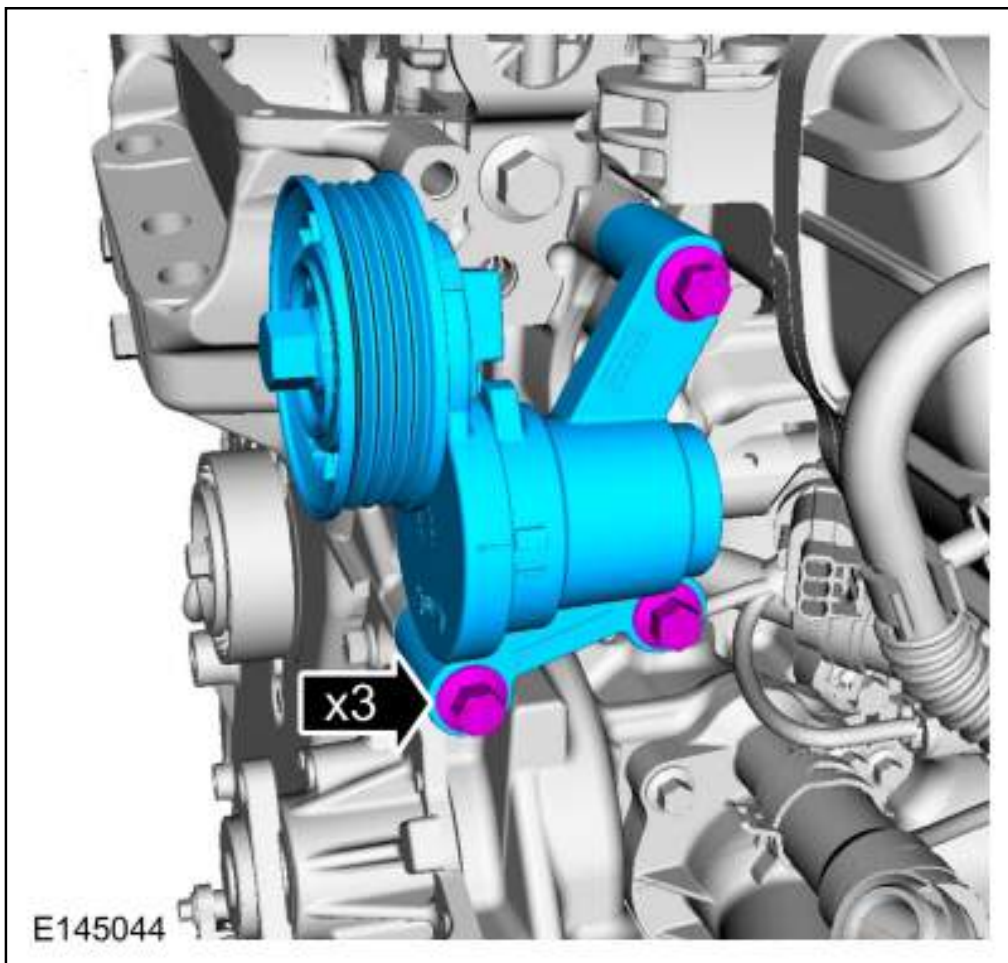

9.

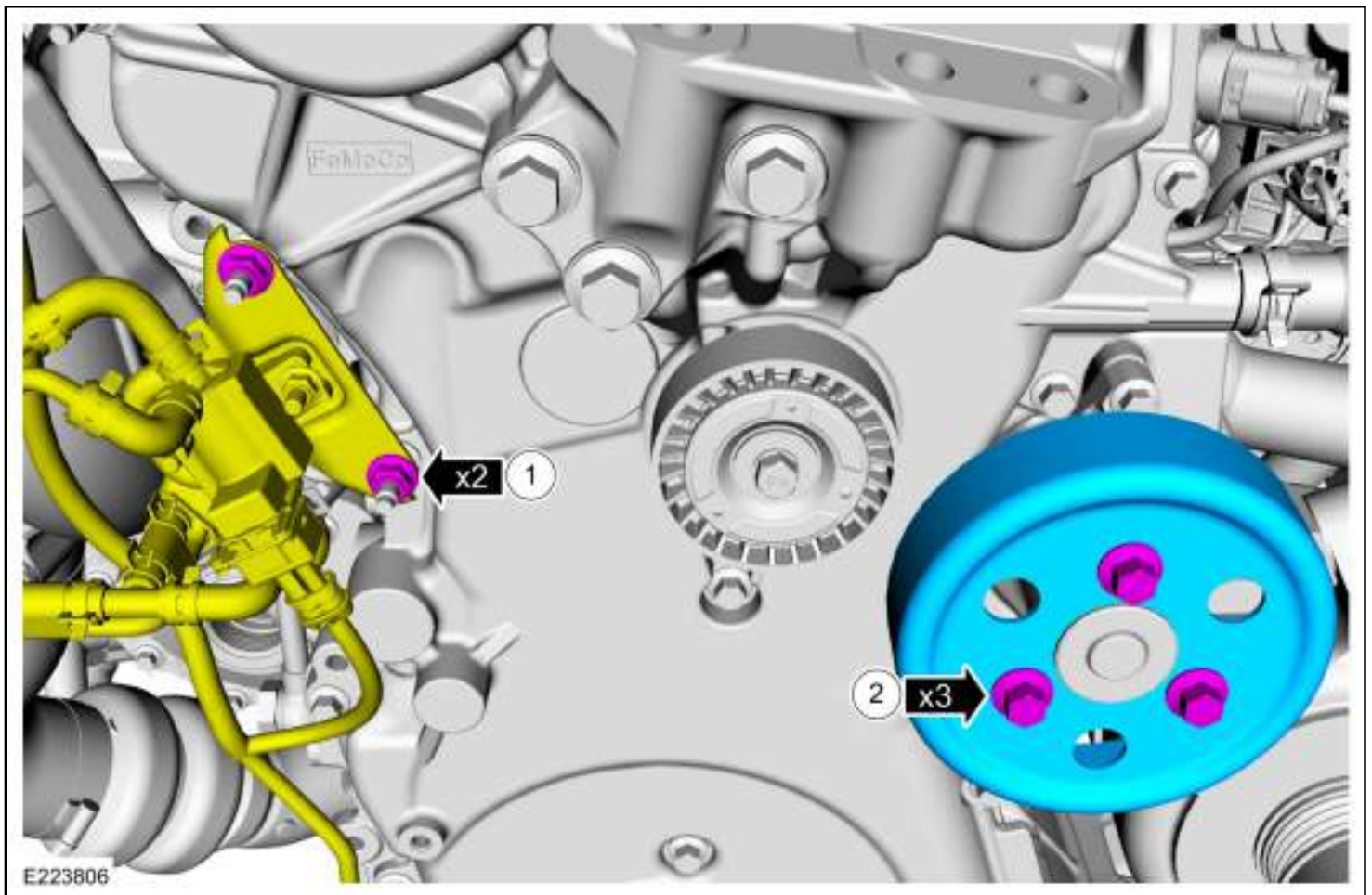

10.

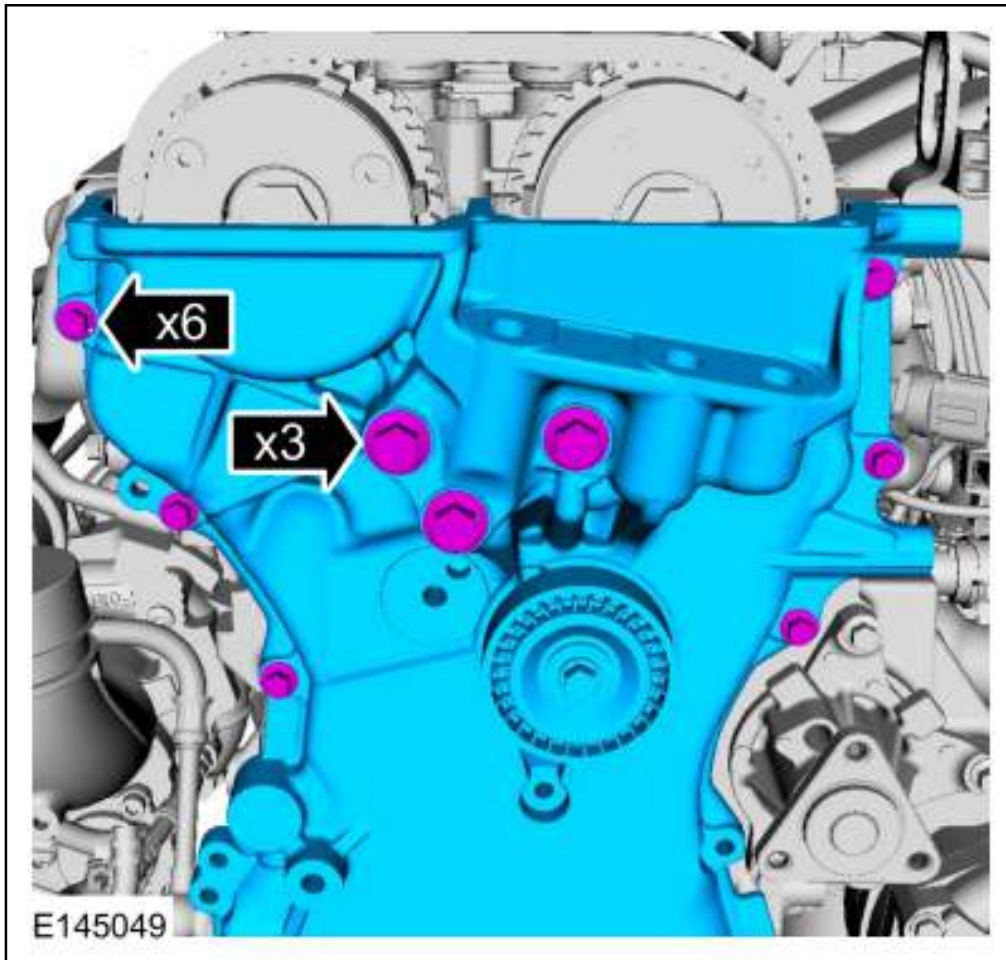

## Installation

1. To install, reverse the removal procedure.
2. **NOTE:** *Make sure that the component is clean, free of foreign material and lubricant.*

Use the General Equipment: Plastic Scraper

Material: Motorcraft® Metal Surface Prep Wipes / ZC-31-B

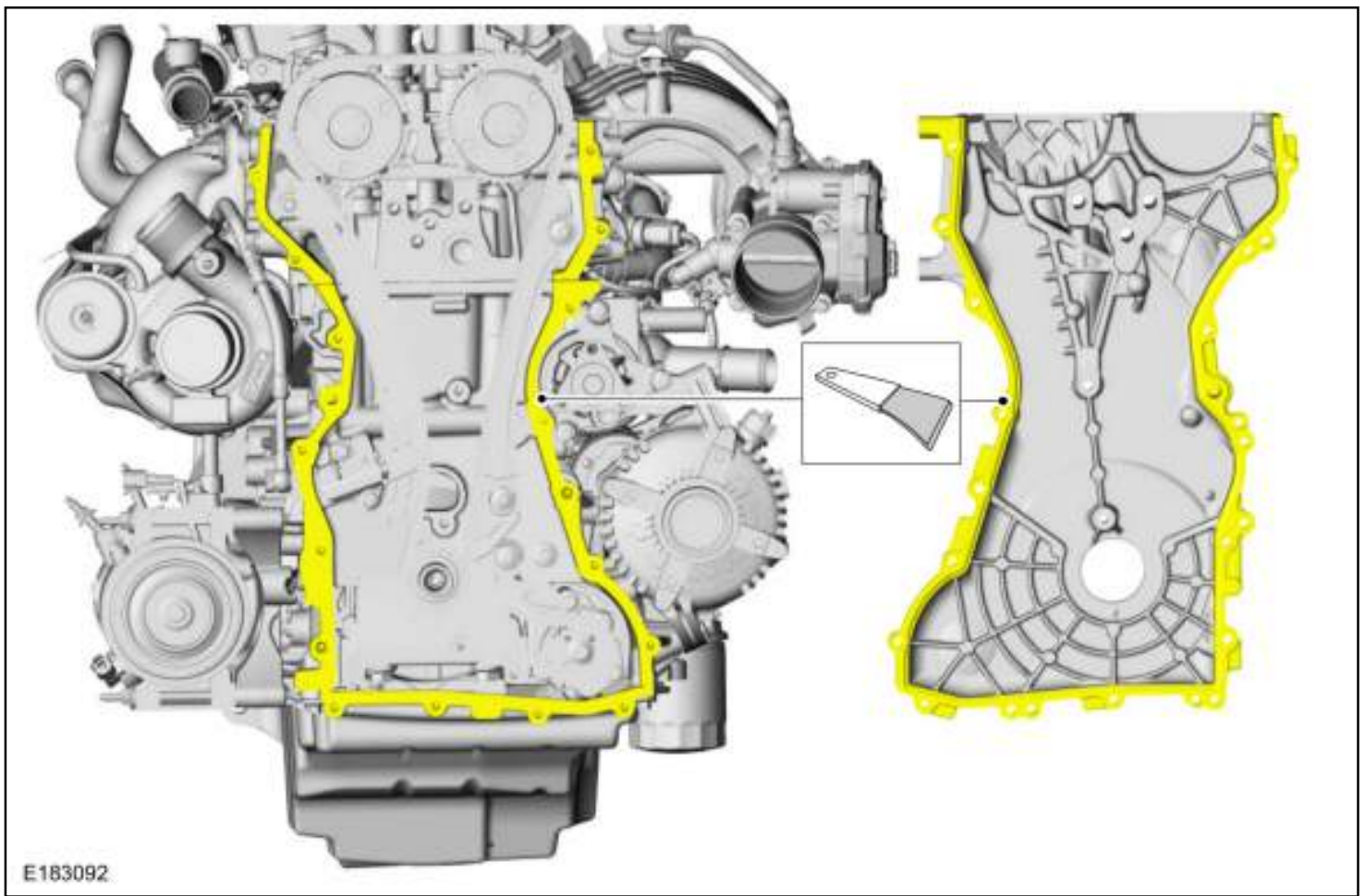

3. **NOTE:** *The component must be installed within 10 minutes of applying the sealant.*

*Material: Motorcraft® High Performance Engine RTV Silicone / TA-357 (WSE-M4G323-A6)*

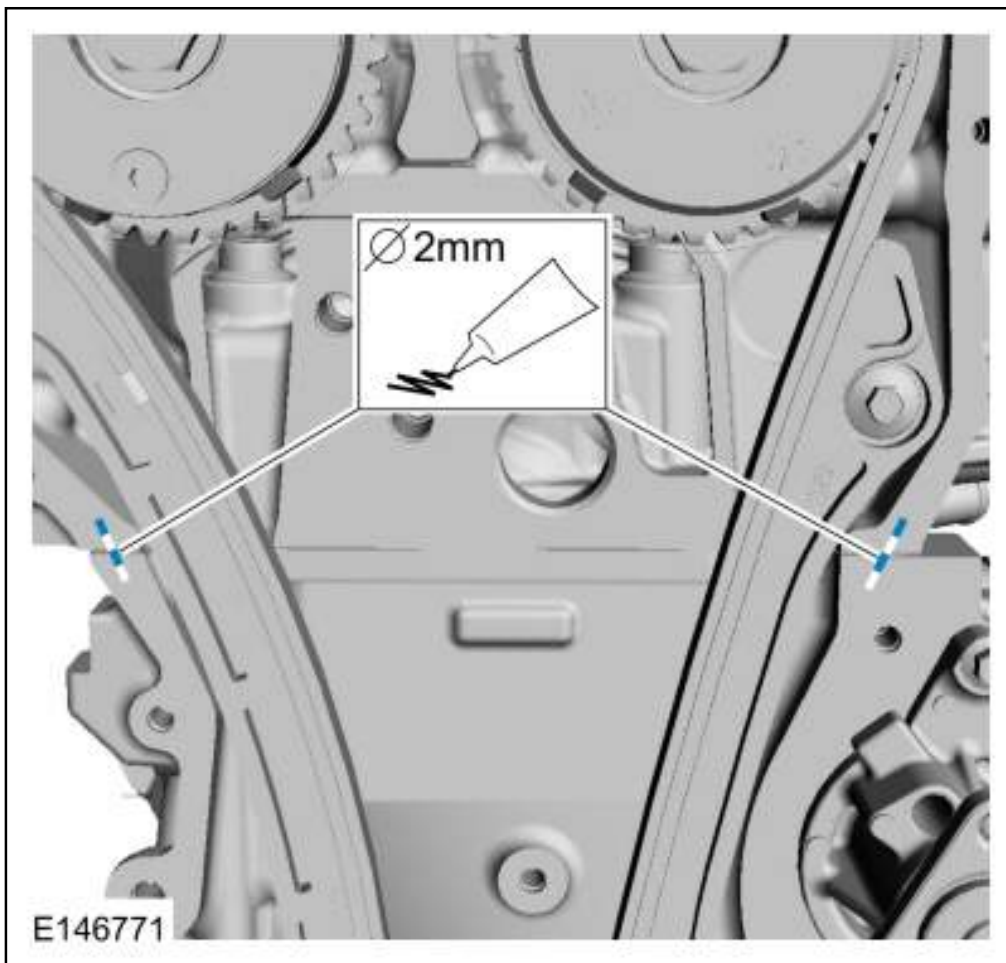

4. **NOTE:** *The component must be installed within 10 minutes of applying the sealant.*

*Material:* Motorcraft® High Performance Engine RTV Silicone / TA-357 (WSE-M4G323-A6)

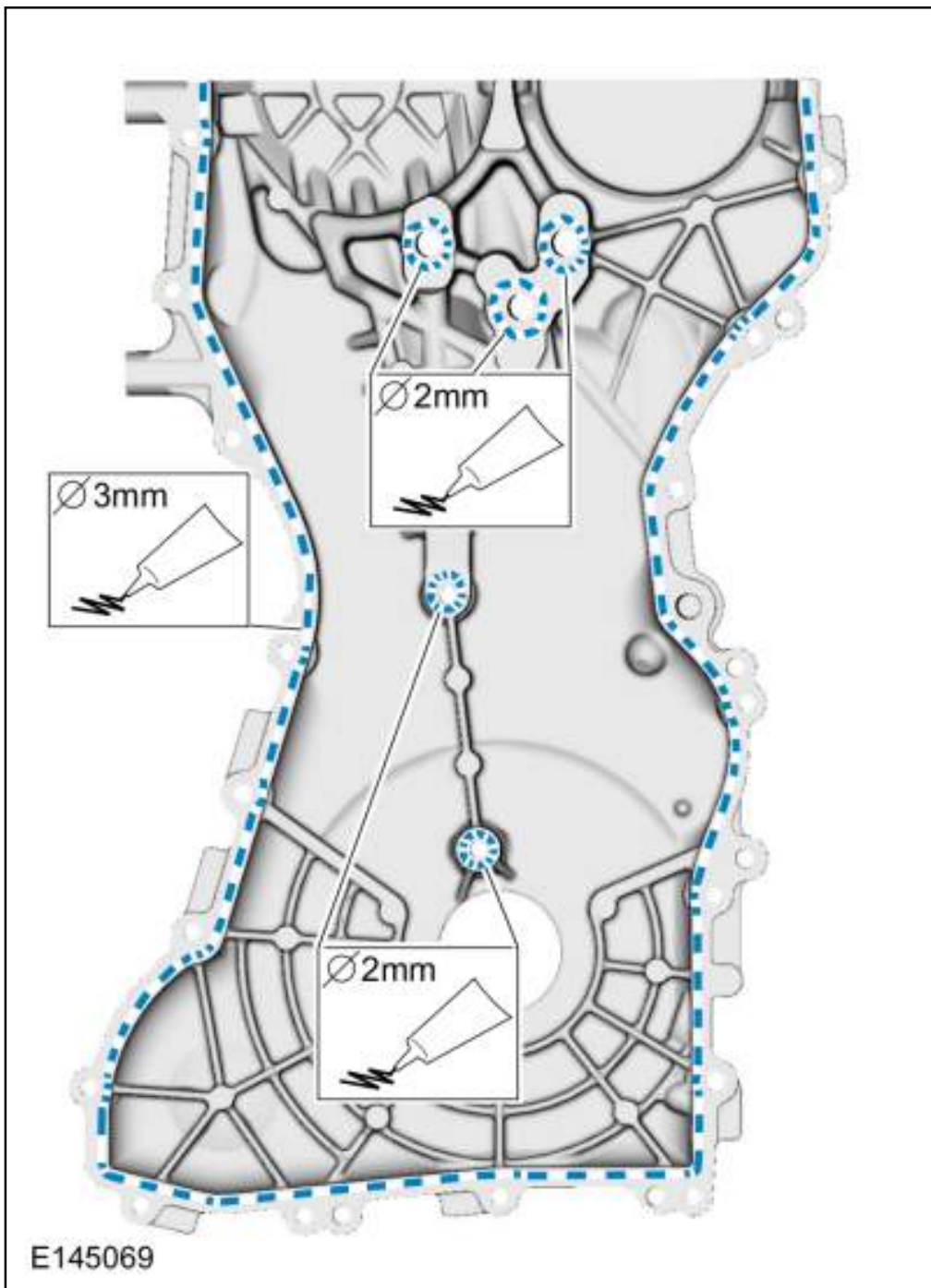

1. **NOTE:** *Install all the bolts finger tight before final tightening.*

2. *Torque:*

1 - 19: 89 lb.in (10 Nm)

3. *Torque:*

20 - 22: 35 lb.ft (48 Nm)

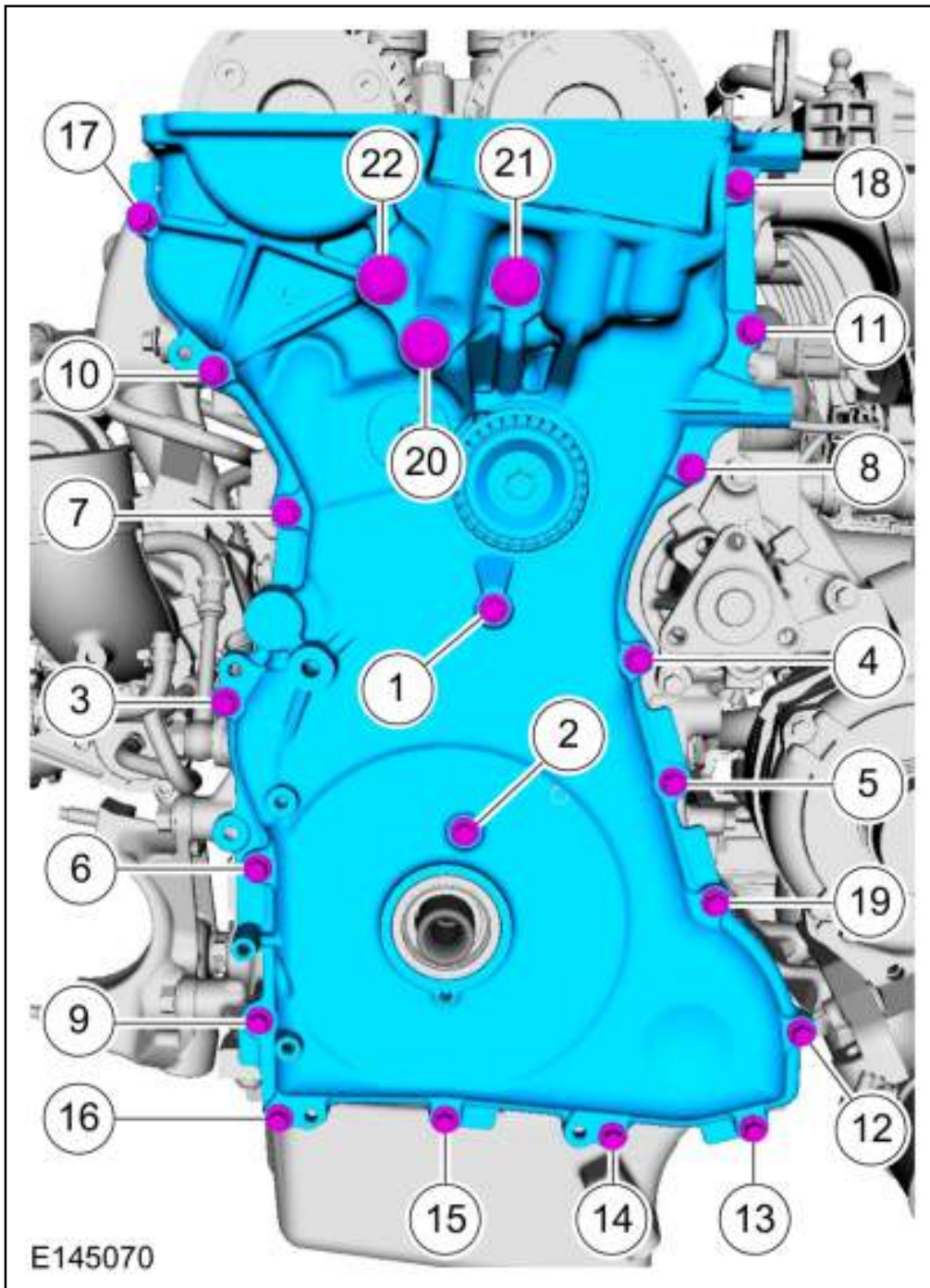

E145070

- 1. Torque: 89 lb.in (10 Nm)
- 2. Torque: 177 lb.in (20 Nm)

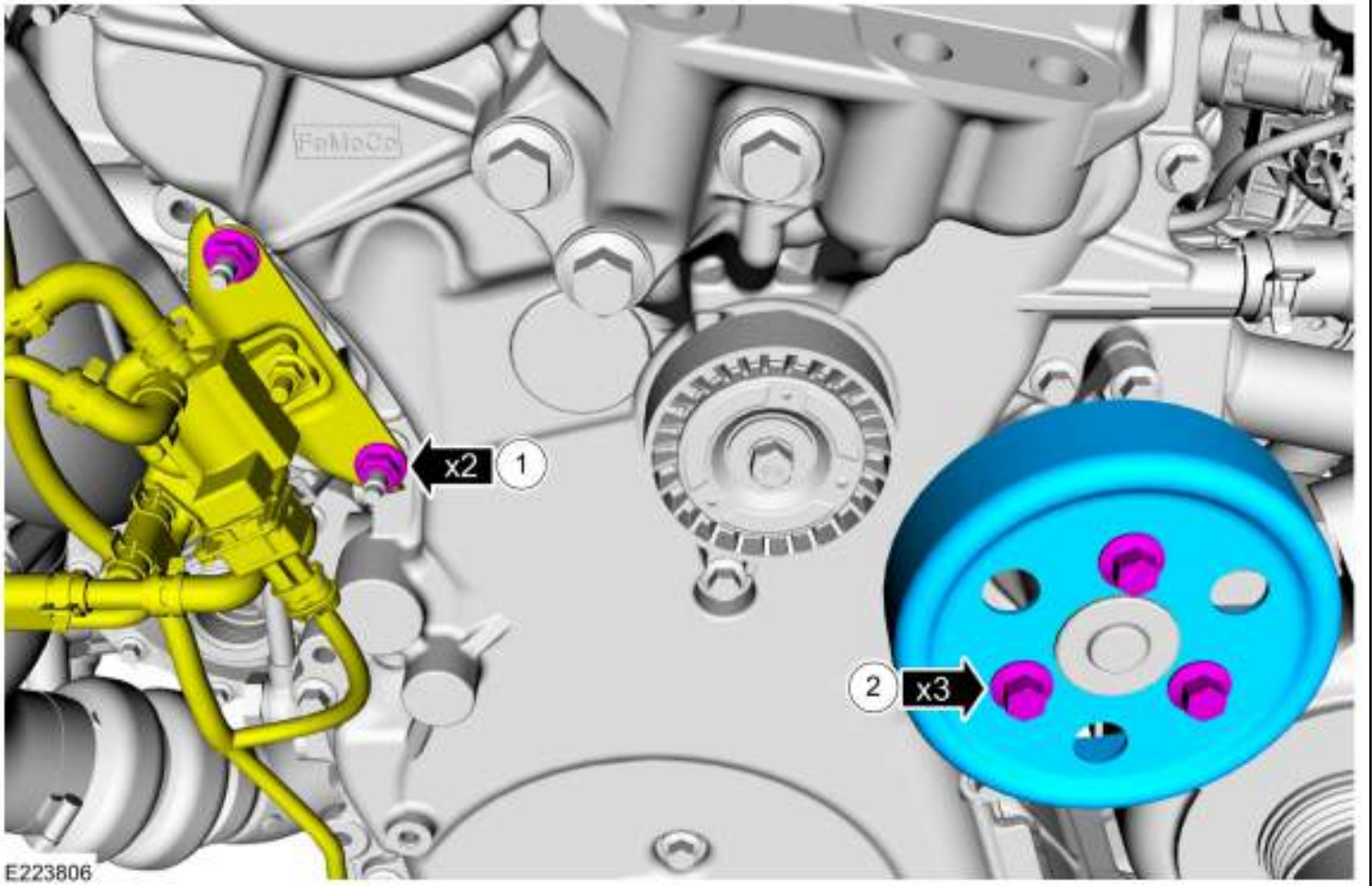

7. *Torque:* 18 lb.ft (24 Nm)

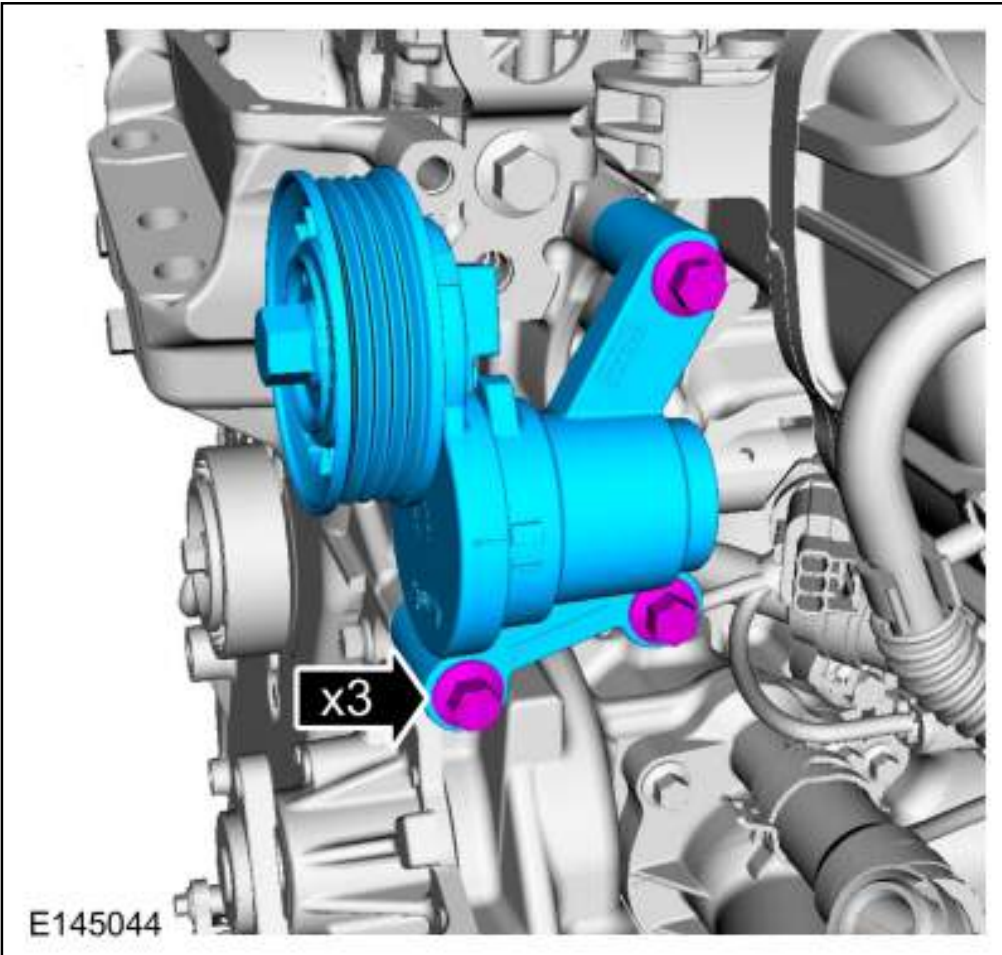

8. *Torque:* 133 lb.in (15 Nm)

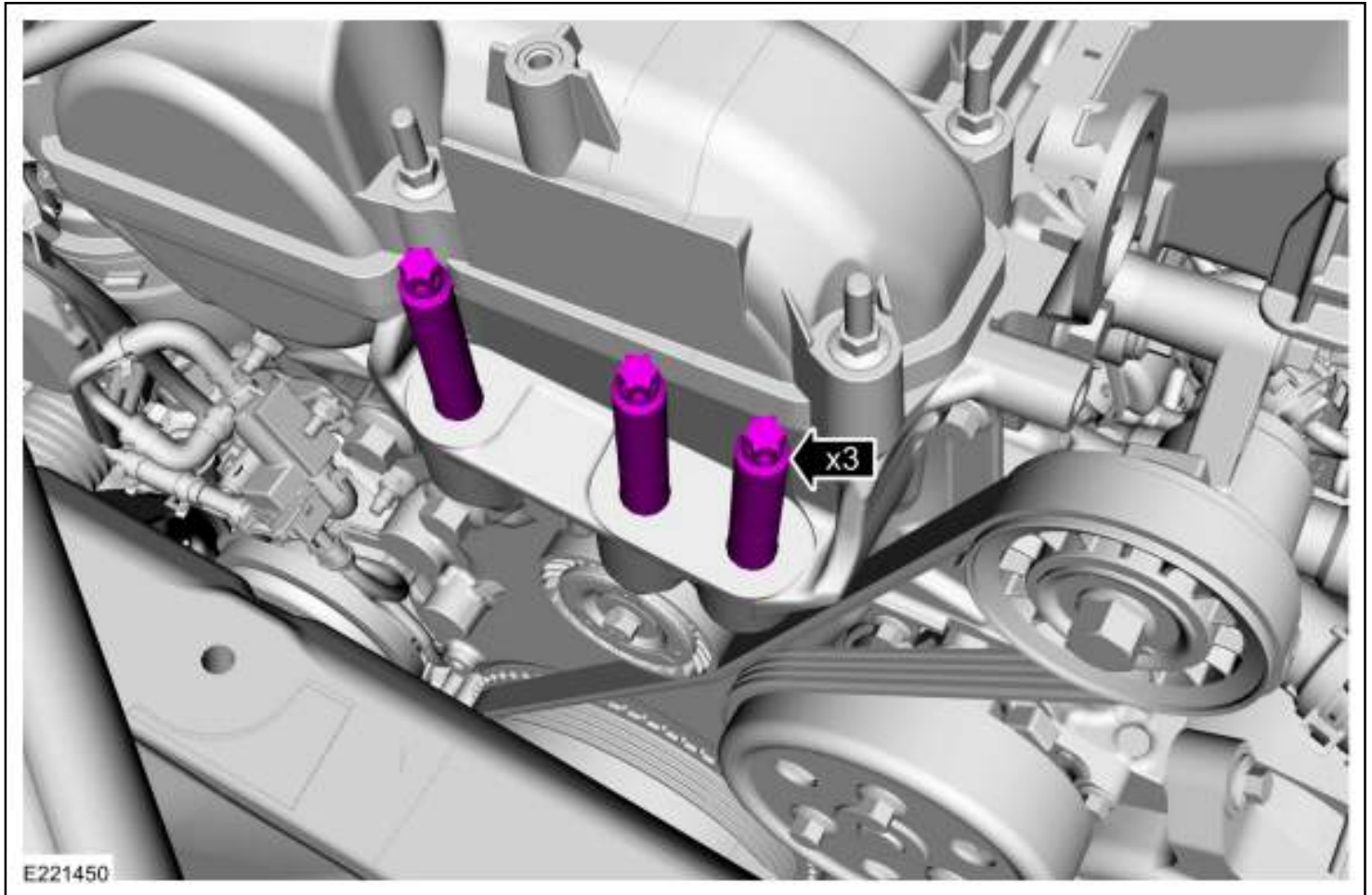

1. *Torque:* 59 lb.ft (80 Nm)
2. **NOTE:** *Only tighten the bolts finger tight at this stage.*

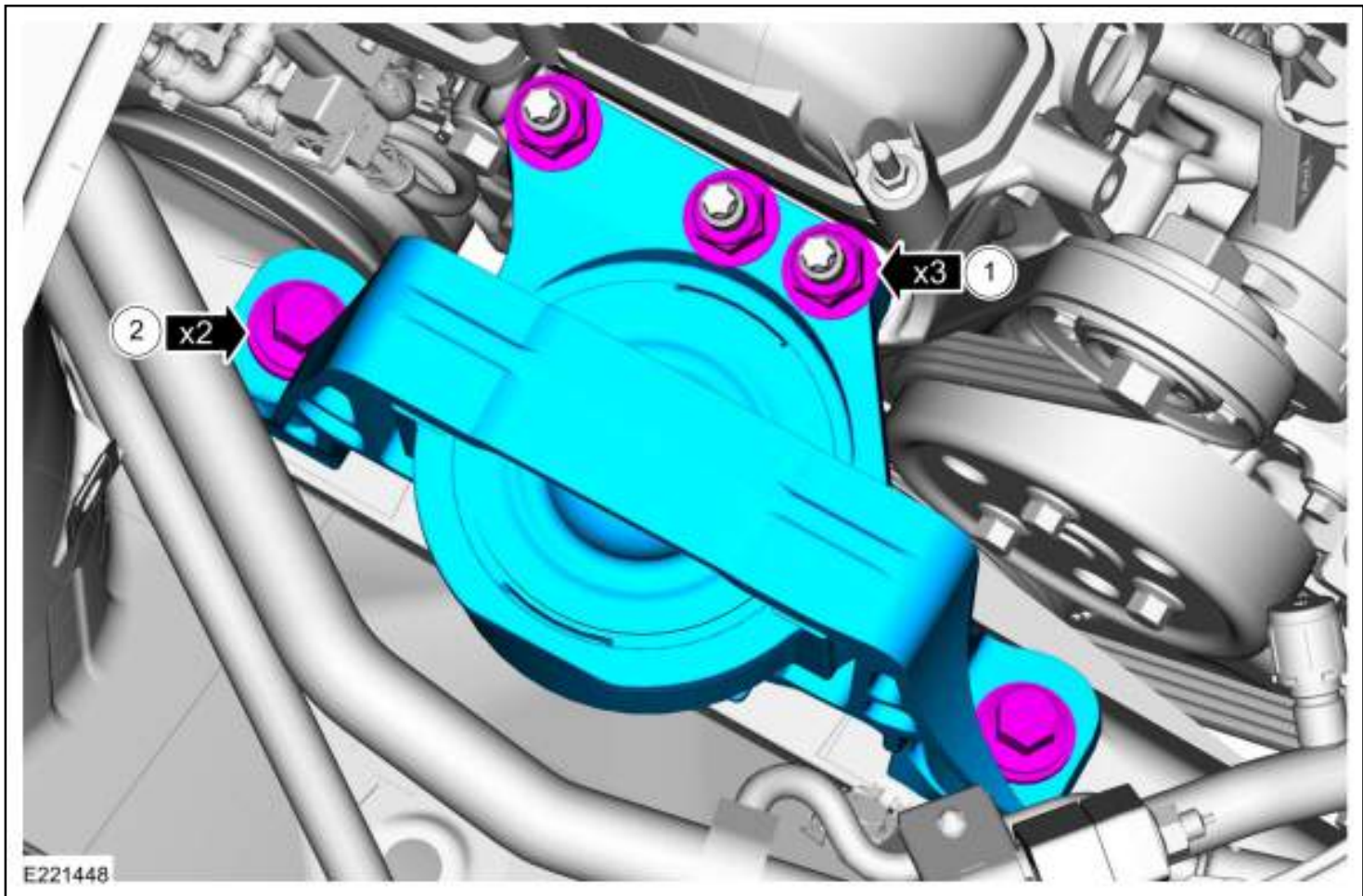

10. **NOTE:** Only tighten the bolts finger tight at this stage.

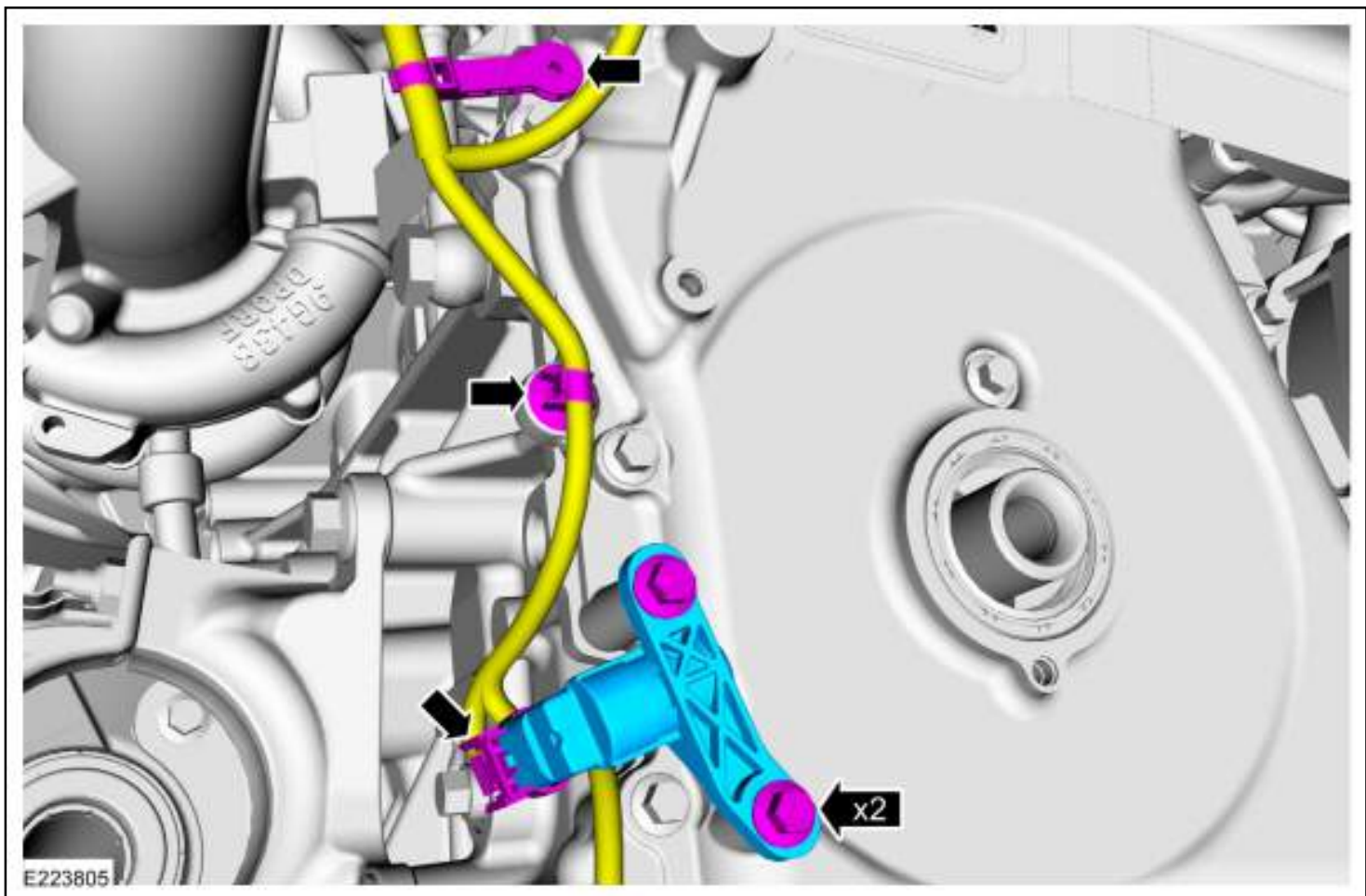

11. Remove Special Service Tool: 303-1554 Engine Support Bar. , 303-290A-15 Adapter for 303-290A.

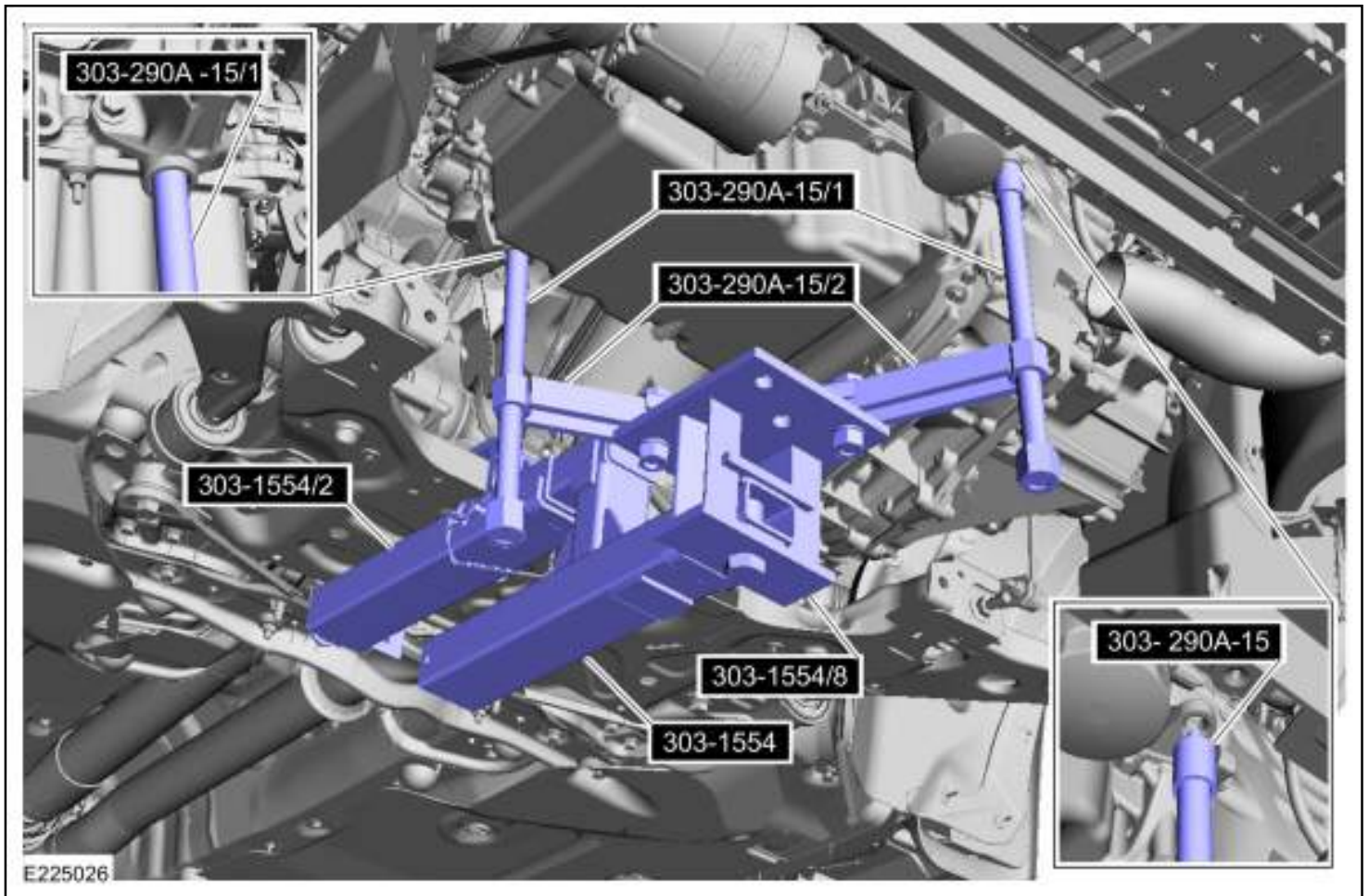

12. Torque: 66 lb.ft (90 Nm)

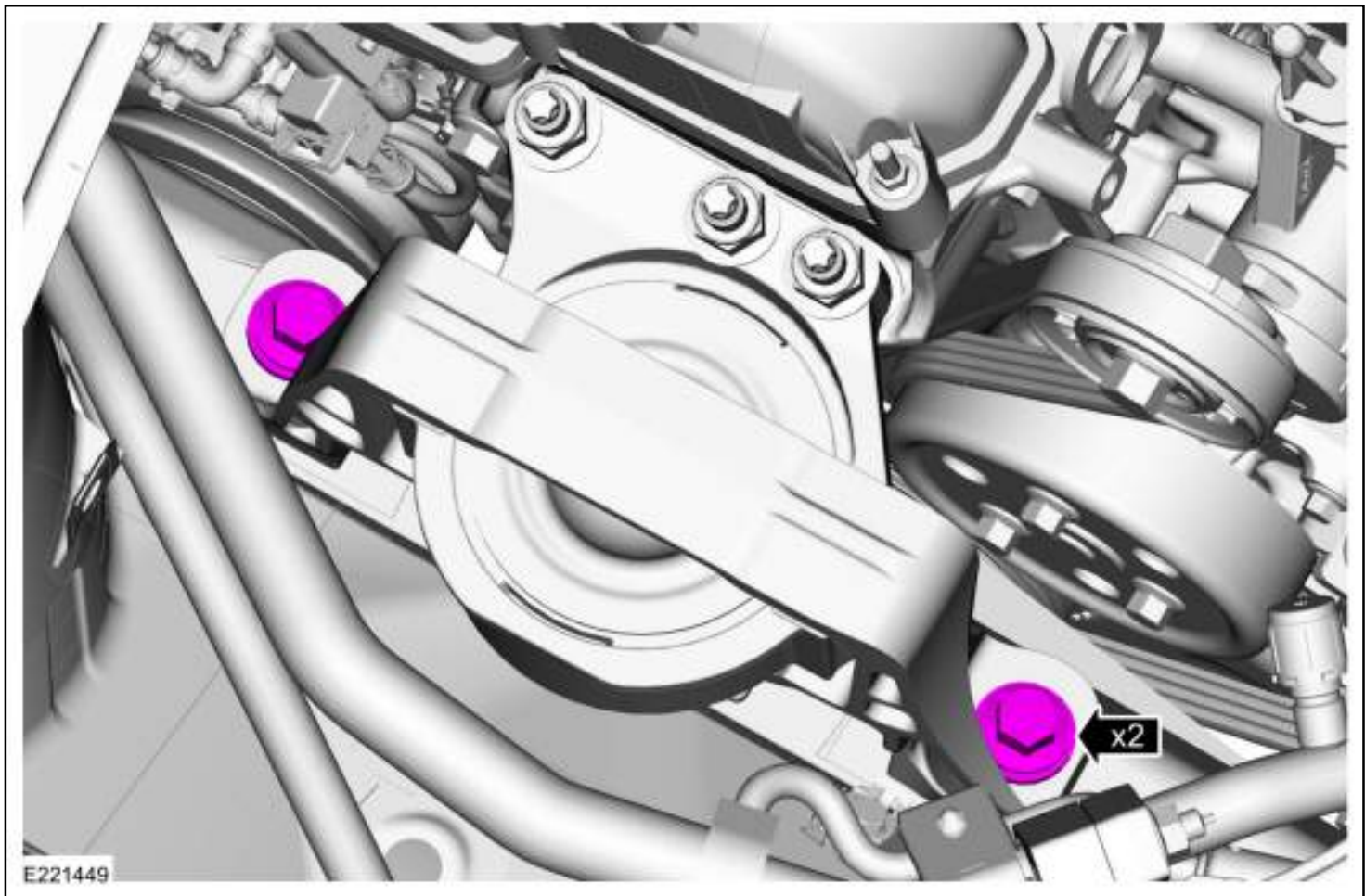

13.

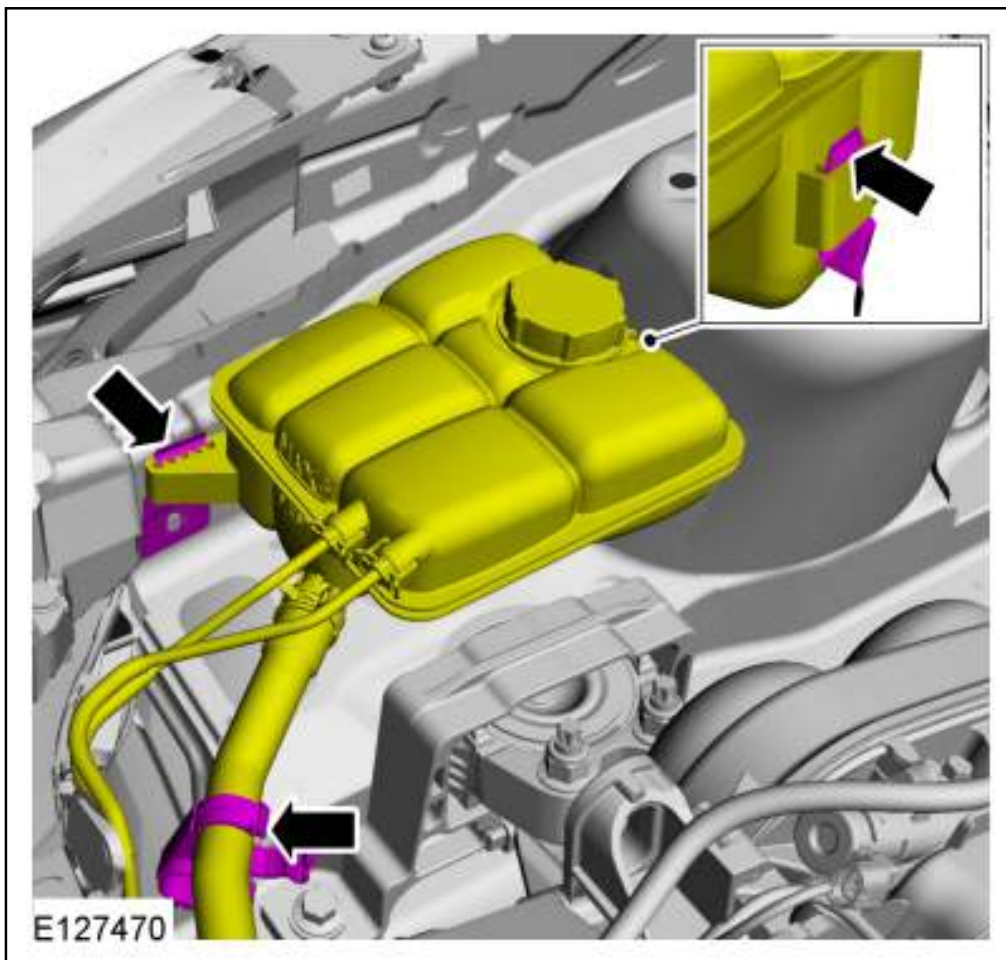

cardiagn.





14. Refer to: [Crankshaft Front Seal](#) (303-01C Engine, Removal and Installation).

Copyright © 2019 Ford Motor Company

---

## Crankshaft Pulley

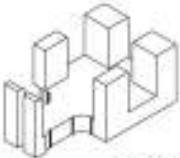
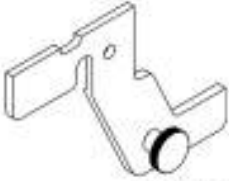
### Special Tool(s) / General Equipment

 <p>E121926</p>	<p>303-1521 Alignment Tool, Crankshaft Position Sensor TKIT-2010C-FLM</p>
 <p>E133912</p>	<p>303-1565 Alignment Tool, Camshaft TKIT-2010C-FLM</p>
 <p>303748</p>	<p>303-748 Locking Tool, Crankshaft TKIT-2010B-FLM TKIT-2010B-ROW</p>
<p>5 mm Drill Bit</p>	

cardiagn.com

### Materials

Name	Specification
Flange Sealant CU7Z-19B508-A	WSS-M2G348-A11

### Removal

1. Remove the following items:
  1. Refer to: [Valve Cover](#) (303-01C Engine, Removal and Installation).
  2. Refer to: [Brake Vacuum Pump - 2.3L EcoBoost \(257kW/350PS\) - MI4 \(206-07 Power Brake Actuation\)](#) .
  3. Refer to: [Accessory Drive Belt \(303-05 Accessory Drive - 2.3L EcoBoost \(257kW/350PS\) - MI4\)](#) .

2. **NOTICE:** Only rotate the crankshaft clockwise.

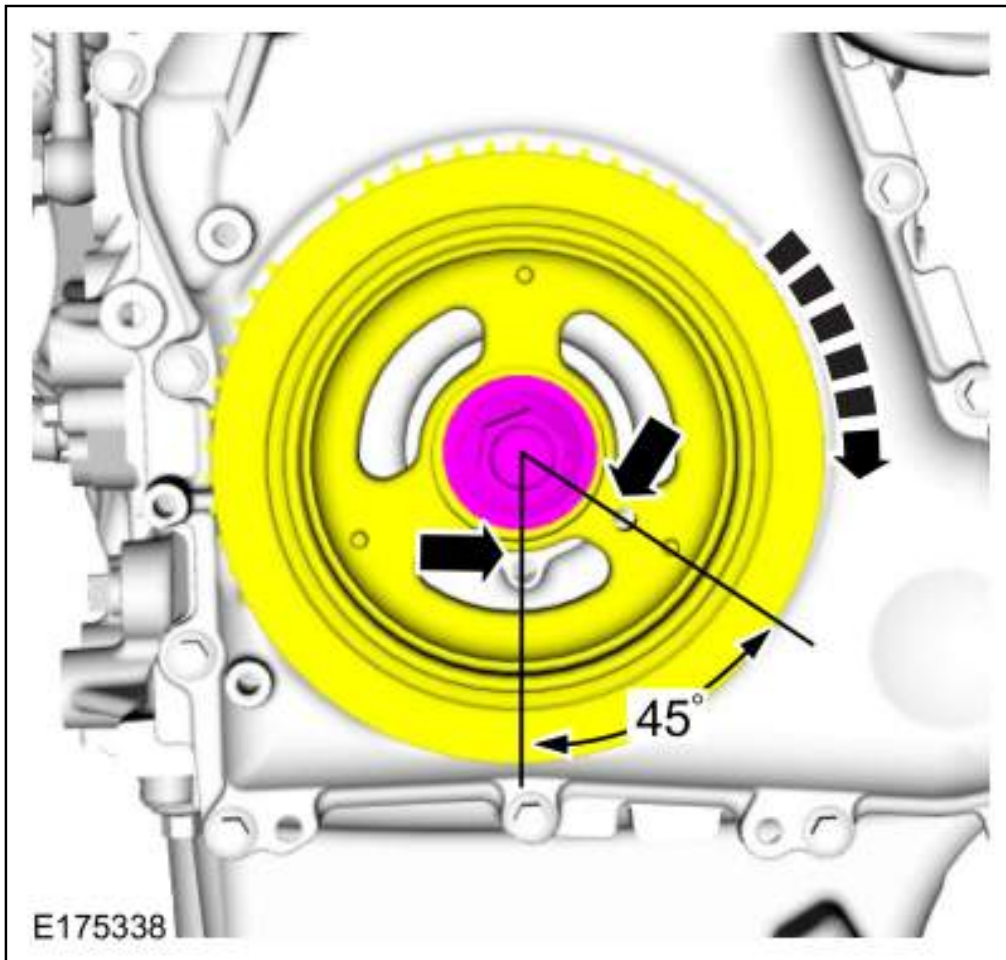

2. Install Special Service Tool: 303-748 Locking Tool, Crankshaft.

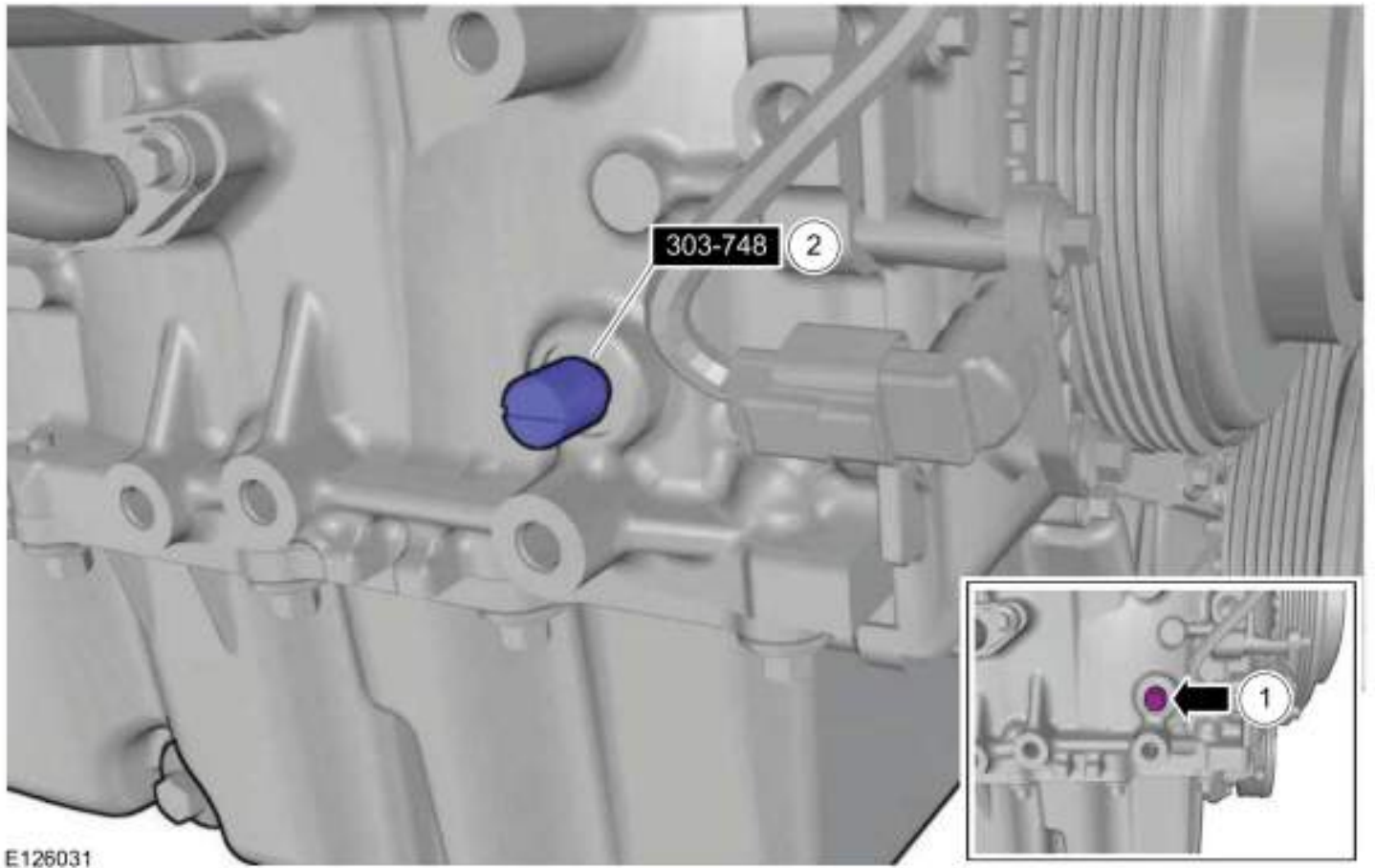

4. **NOTICE: Only rotate the crankshaft clockwise.**

Rotate the crankshaft slowly until the crankshaft stops.  
Use Special Service Tool: 303-748 Locking Tool, Crankshaft.

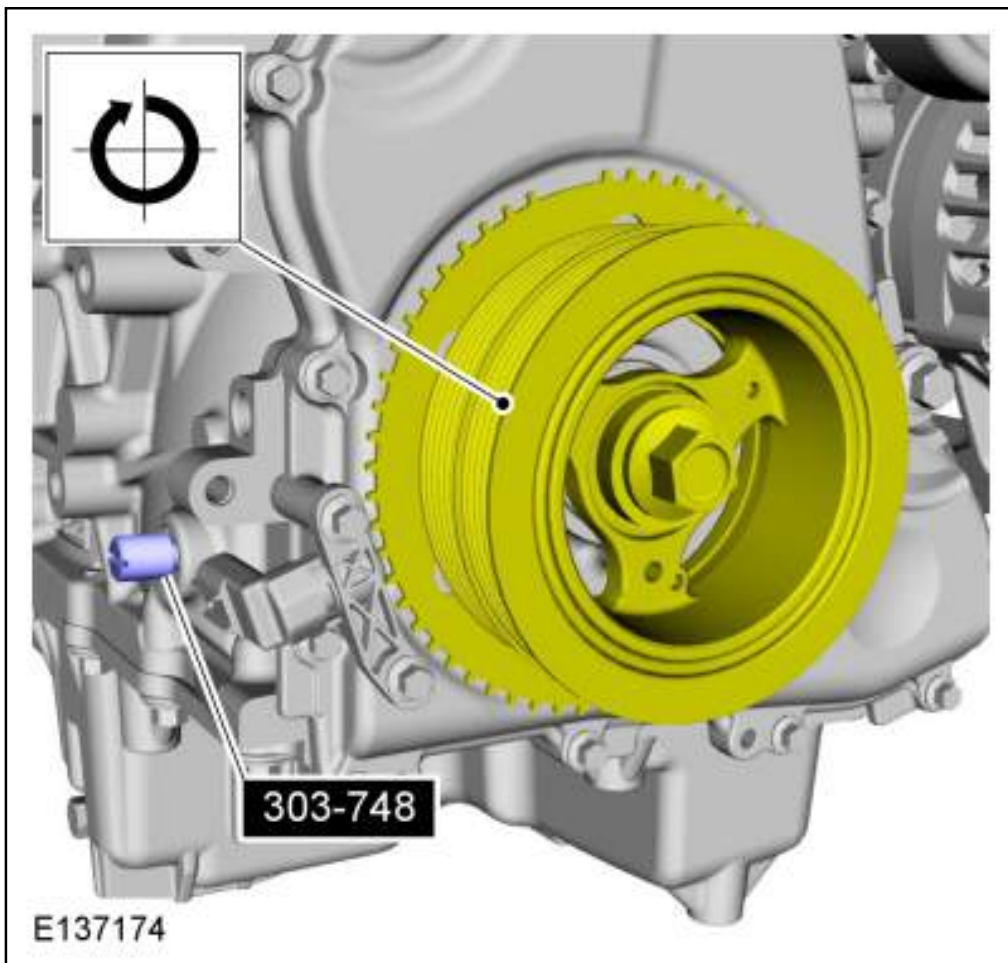

5.

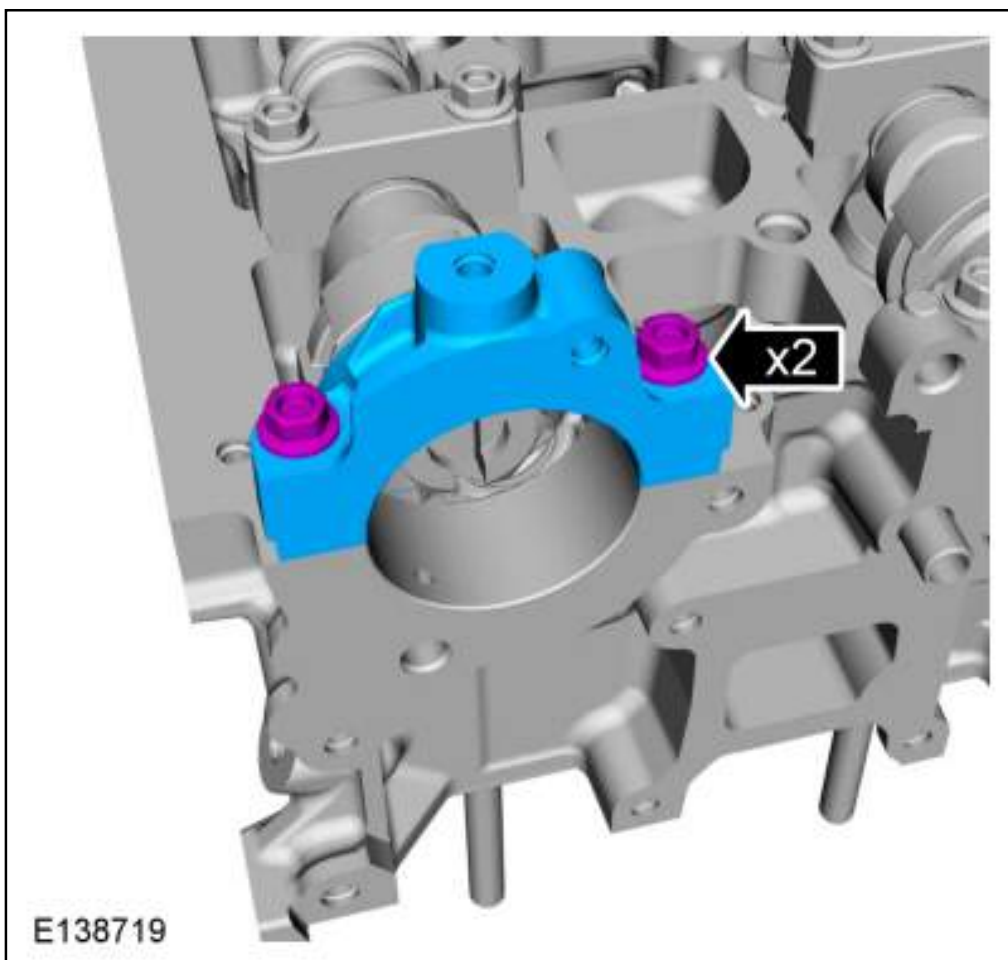

6. **NOTICE:** Use an open-ended wrench to prevent the component from turning.

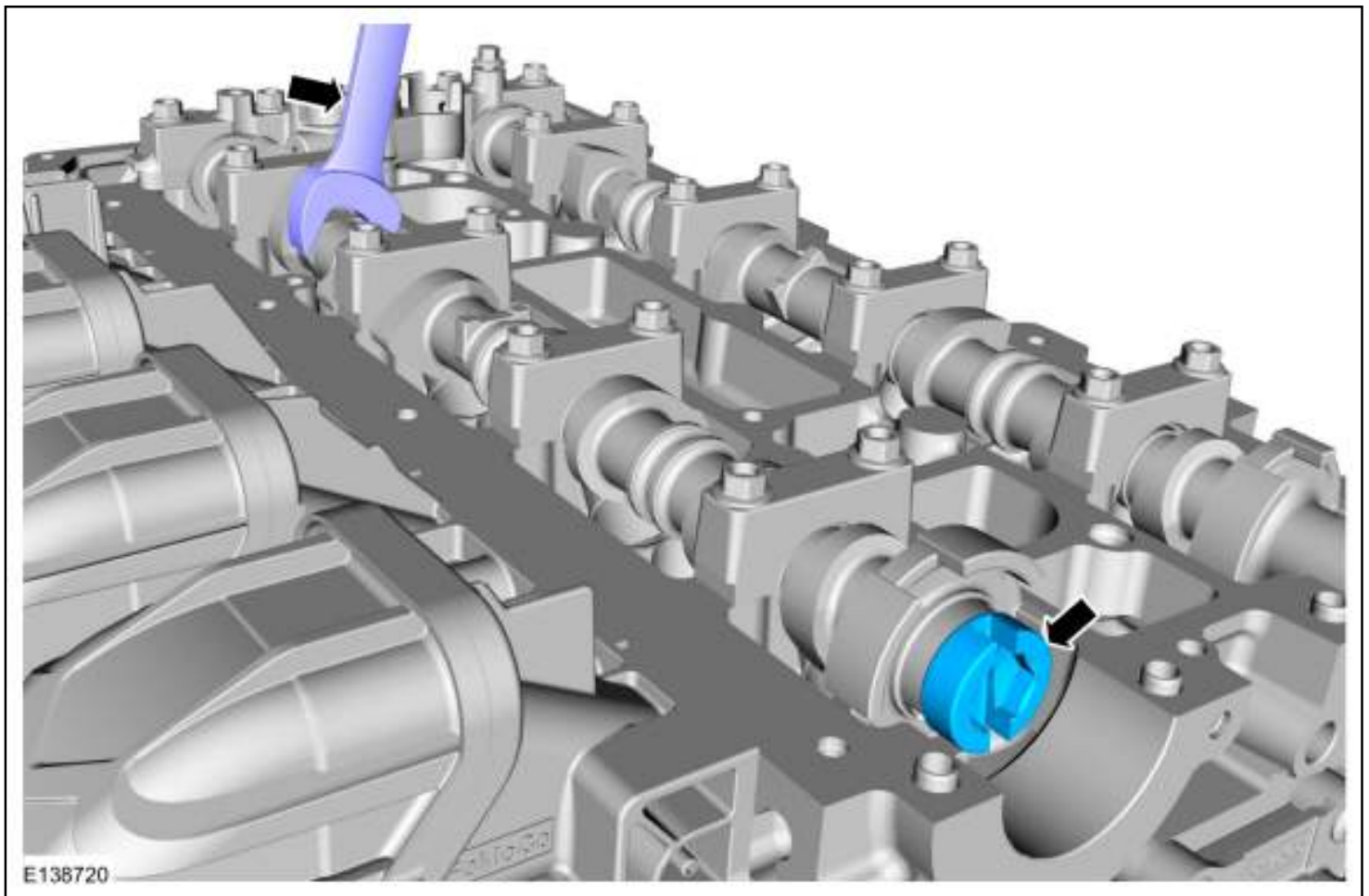

7. Install Special Service Tool: 303-1565 Alignment Tool, Camshaft.

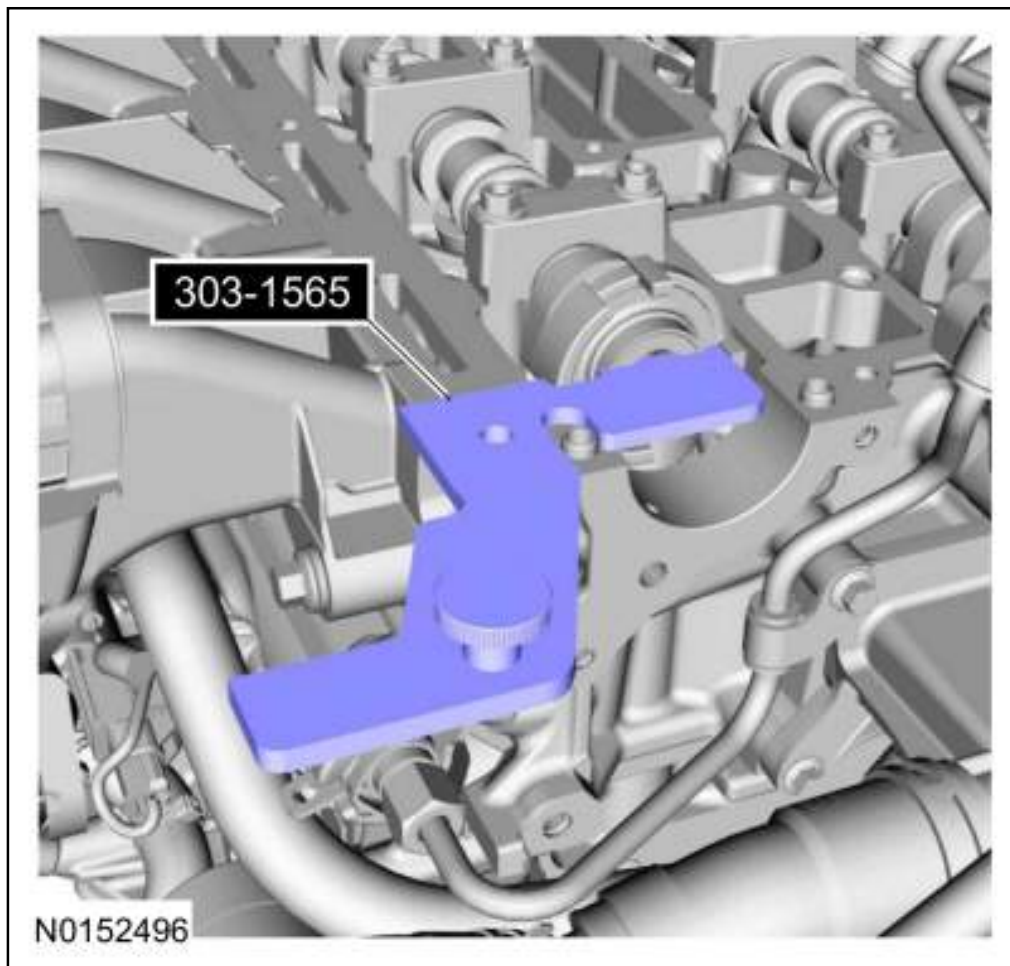

8.

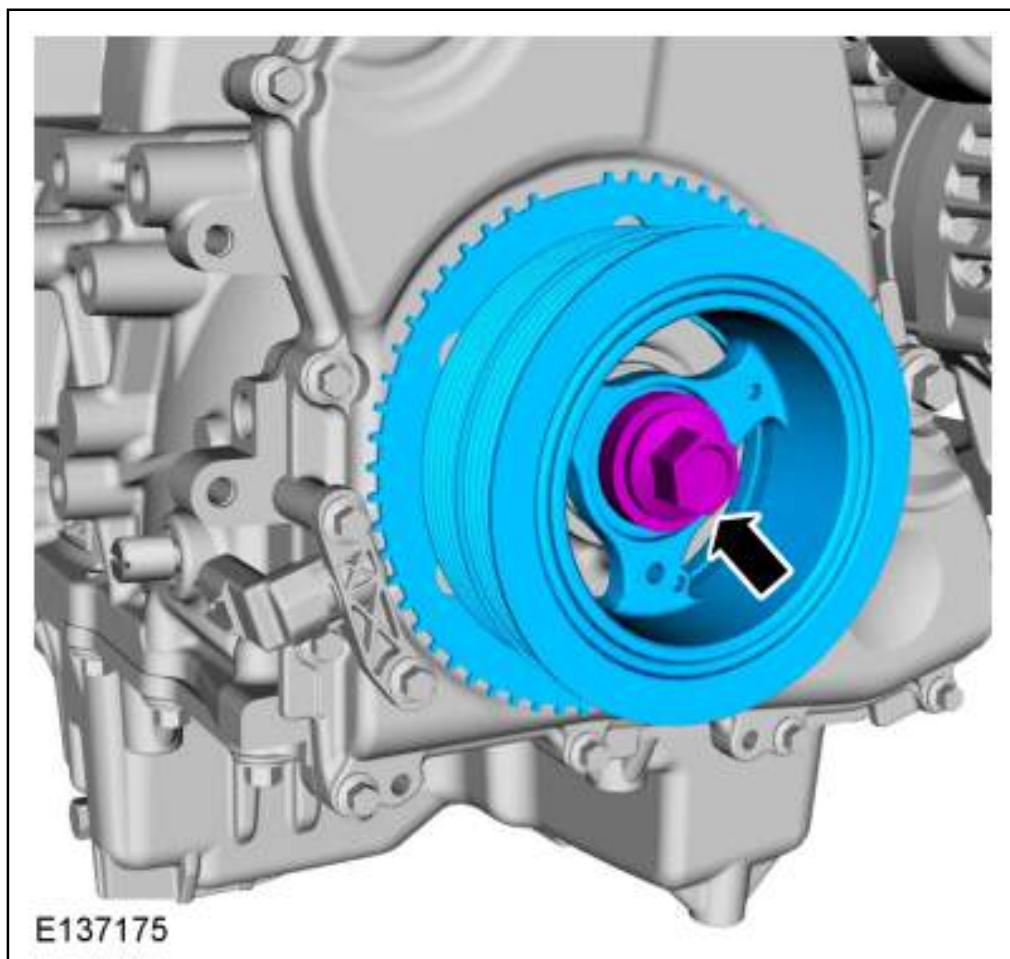

## Installation

### 1. **NOTICE:** Only rotate the crankshaft clockwise.

Rotate the crankshaft slowly until the crankshaft stops.

Use Special Service Tool: 303-748 Locking Tool, Crankshaft.

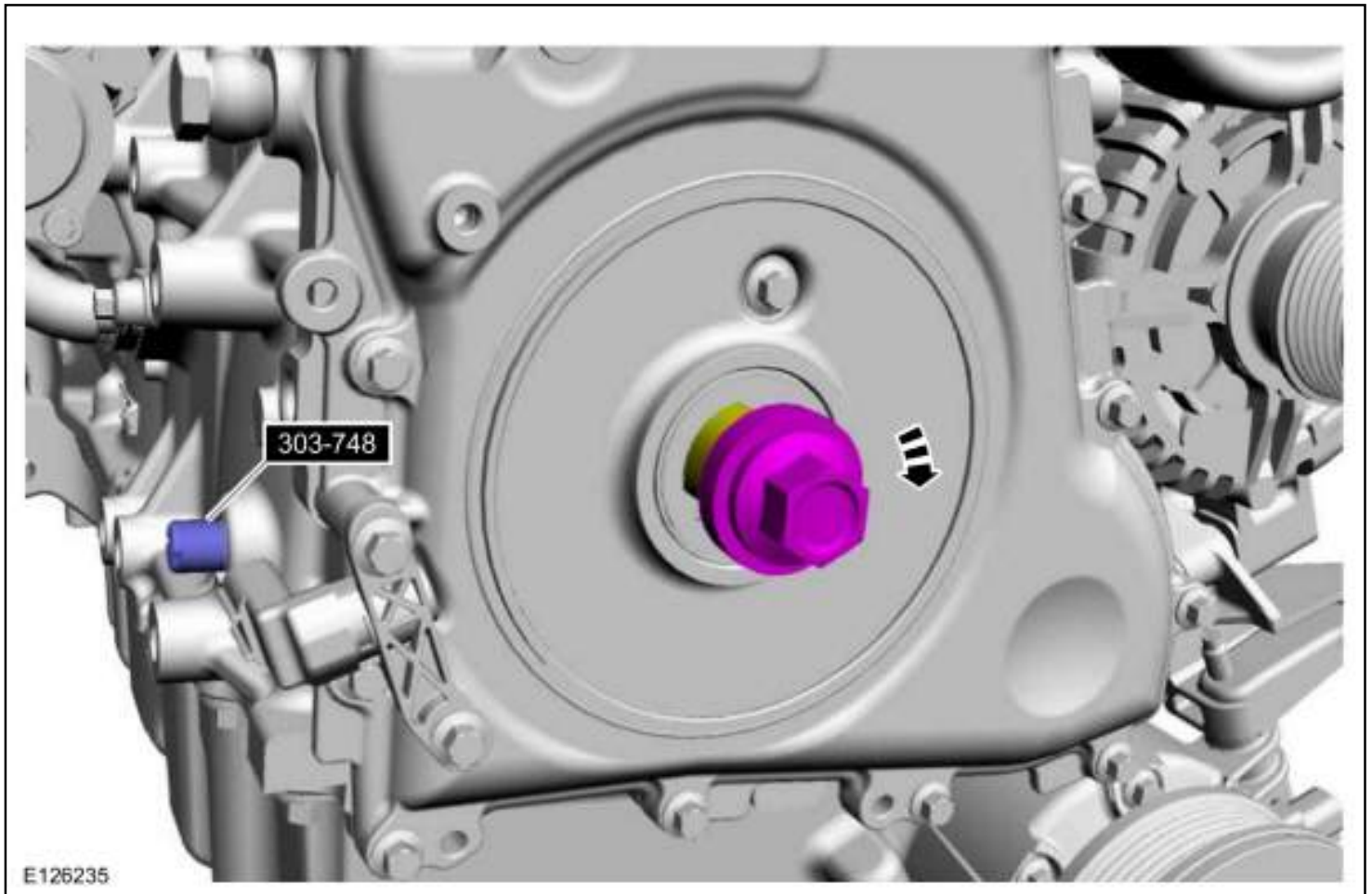

2.

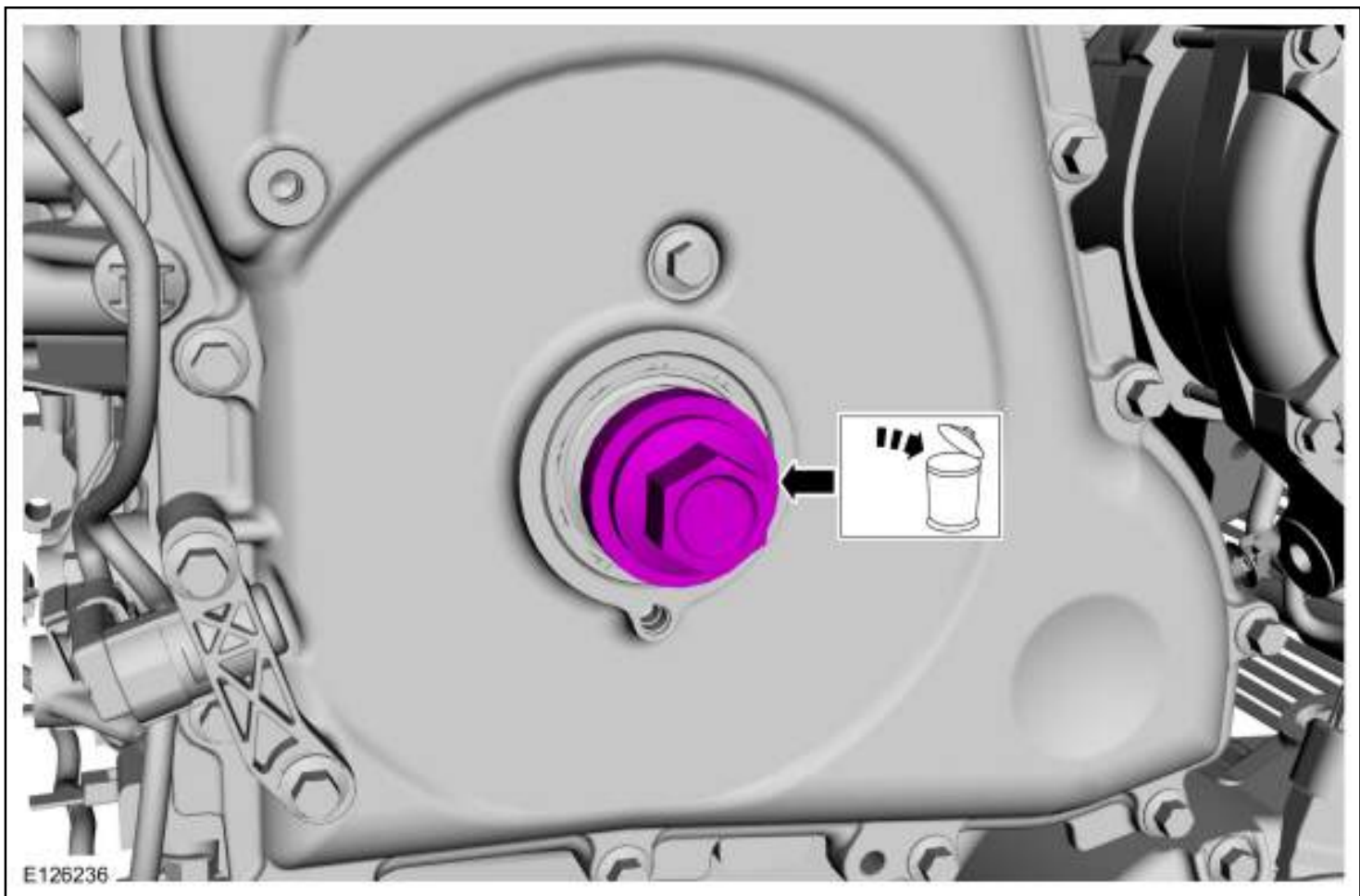

1. Use the General Equipment: 5 mm Drill Bit
2. **NOTE:** *Make sure a new bolt is installed.*

**NOTE:** *Only tighten the bolt finger tight at this stage.*

3. Use the General Equipment: 5 mm Drill Bit
4. **Torque:**  
Stage 1: 74 lb.ft (100 Nm)  
Stage 2: 180°



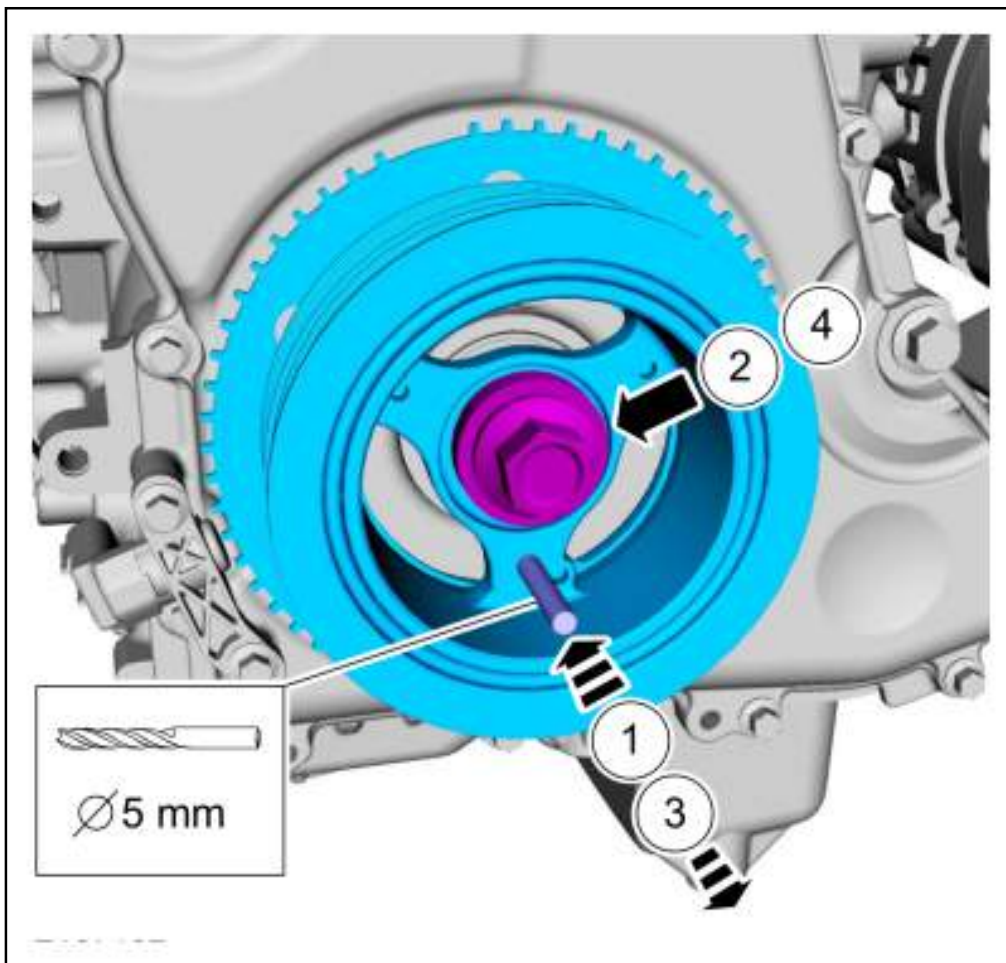

4. Remove Special Service Tool: 303-748 Locking Tool, Crankshaft.

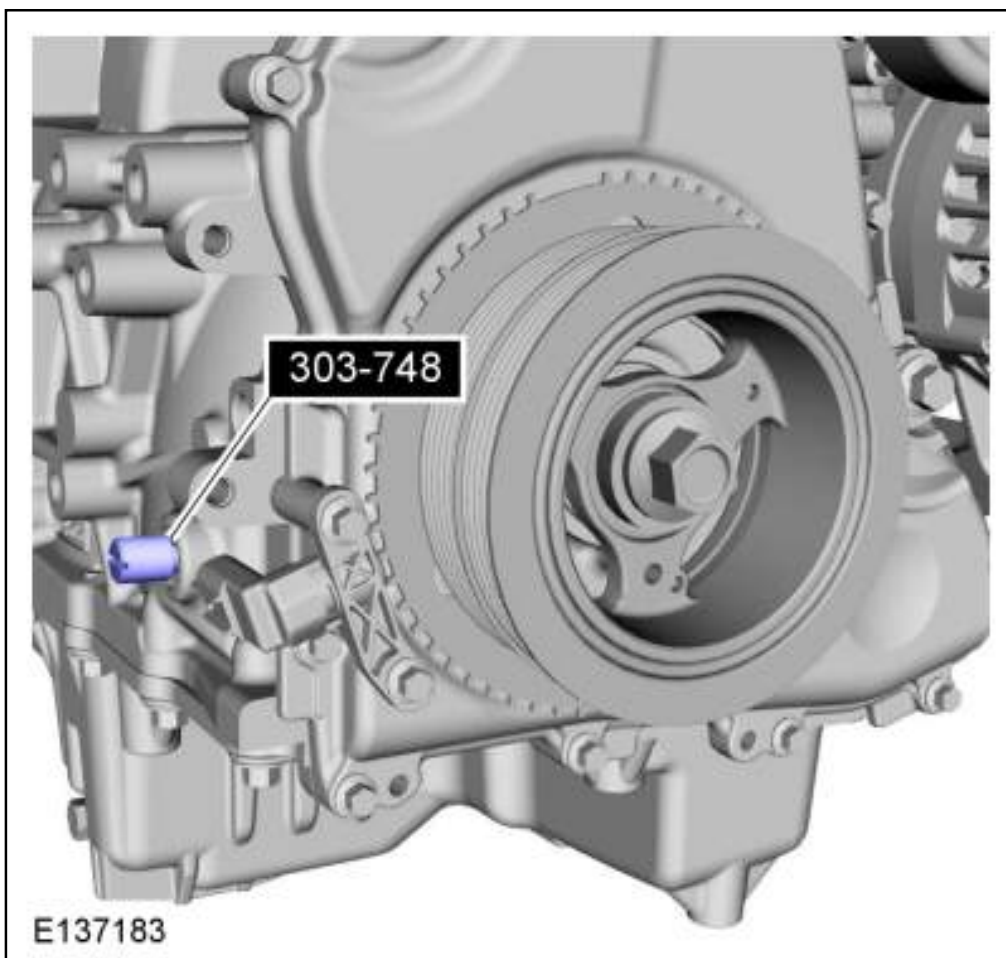

5. Remove Special Service Tool: 303-1565 Alignment Tool, Camshaft.

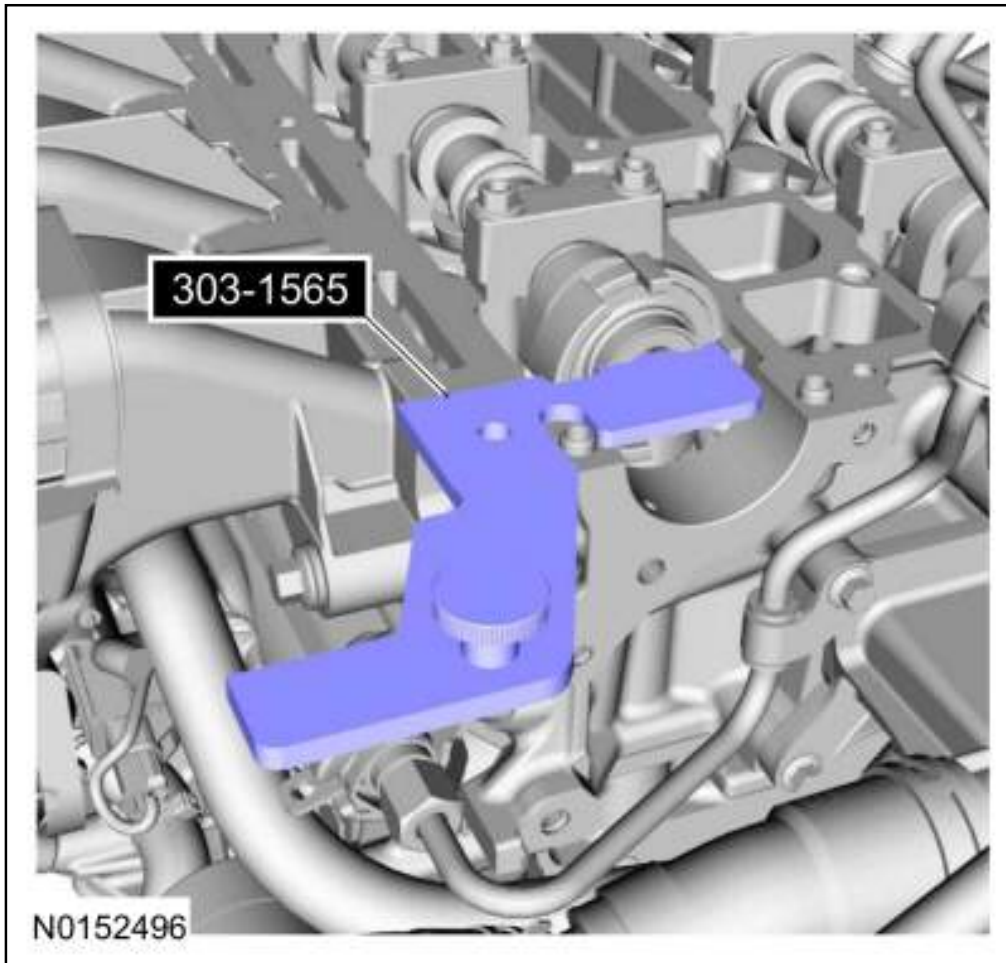

6. **NOTICE:** Only rotate the crankshaft clockwise.

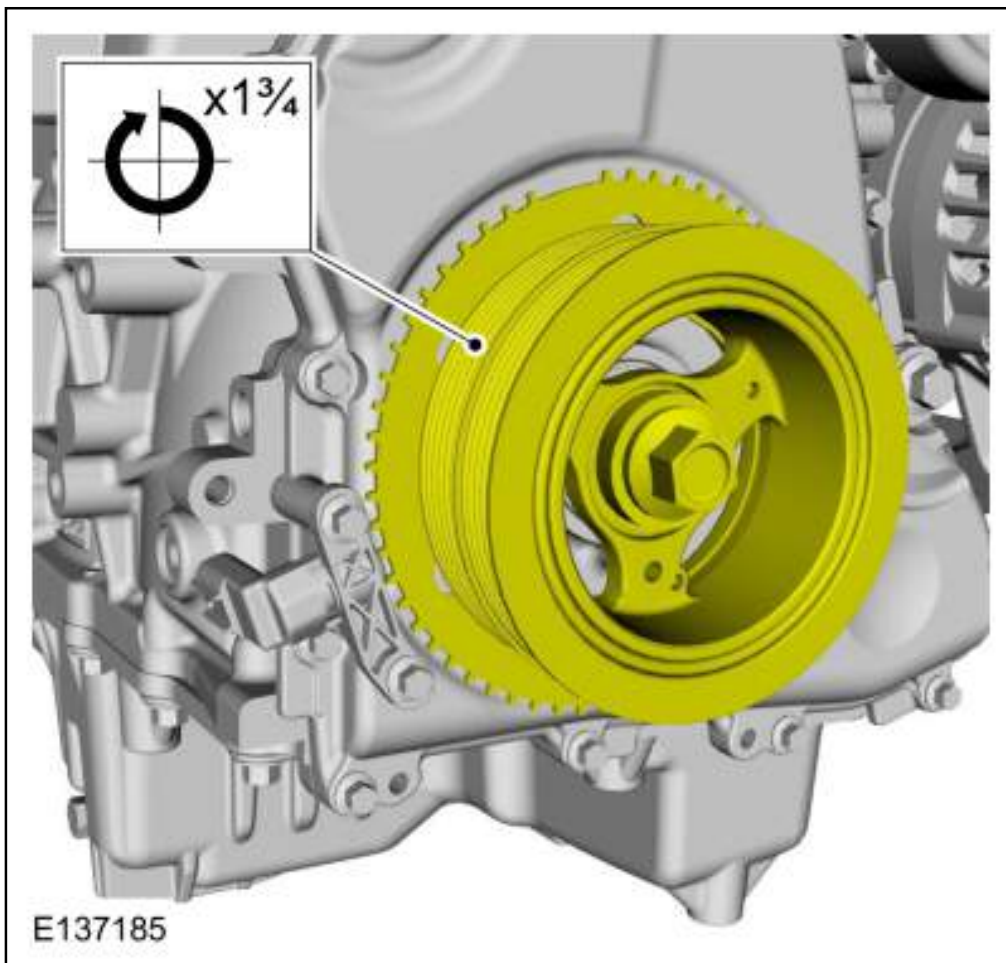

7. Install Special Service Tool: 303-748 Locking Tool, Crankshaft.

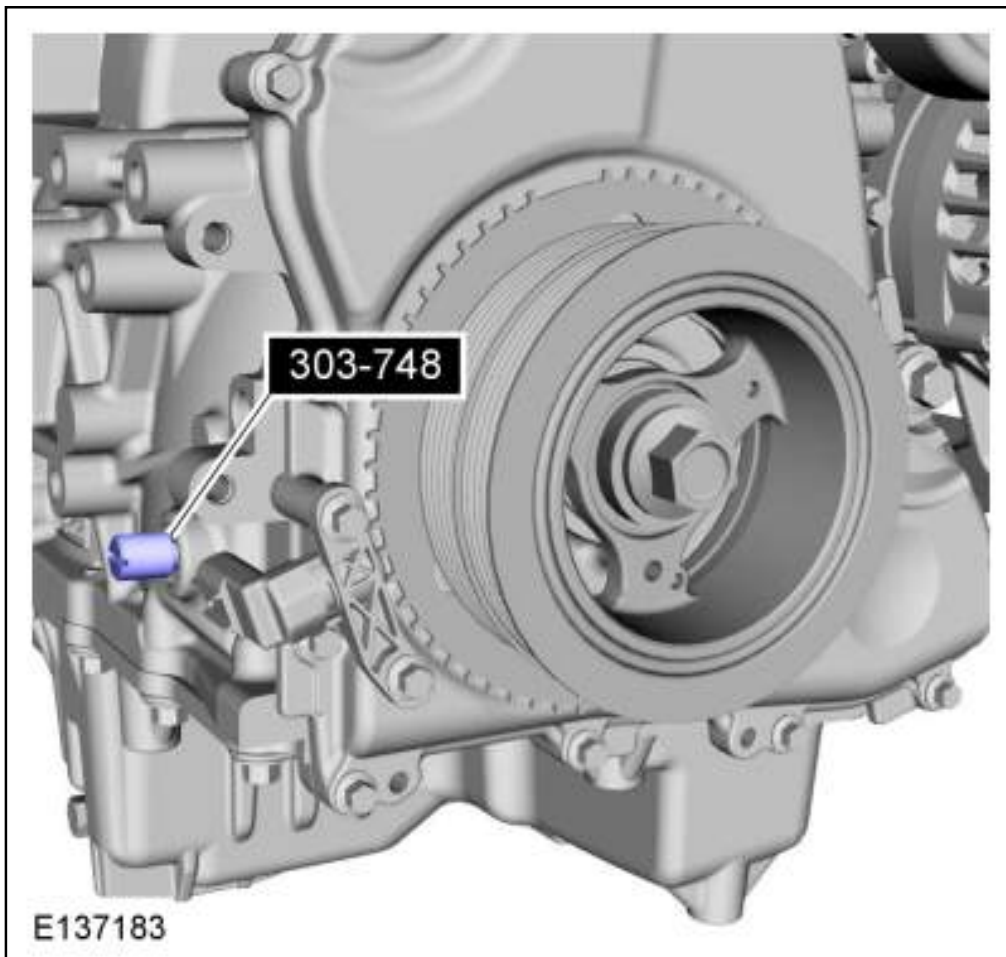

8. **NOTICE:** Only rotate the crankshaft clockwise.

Rotate the crankshaft slowly until the crankshaft stops.

Use Special Service Tool: 303-748 Locking Tool, Crankshaft.

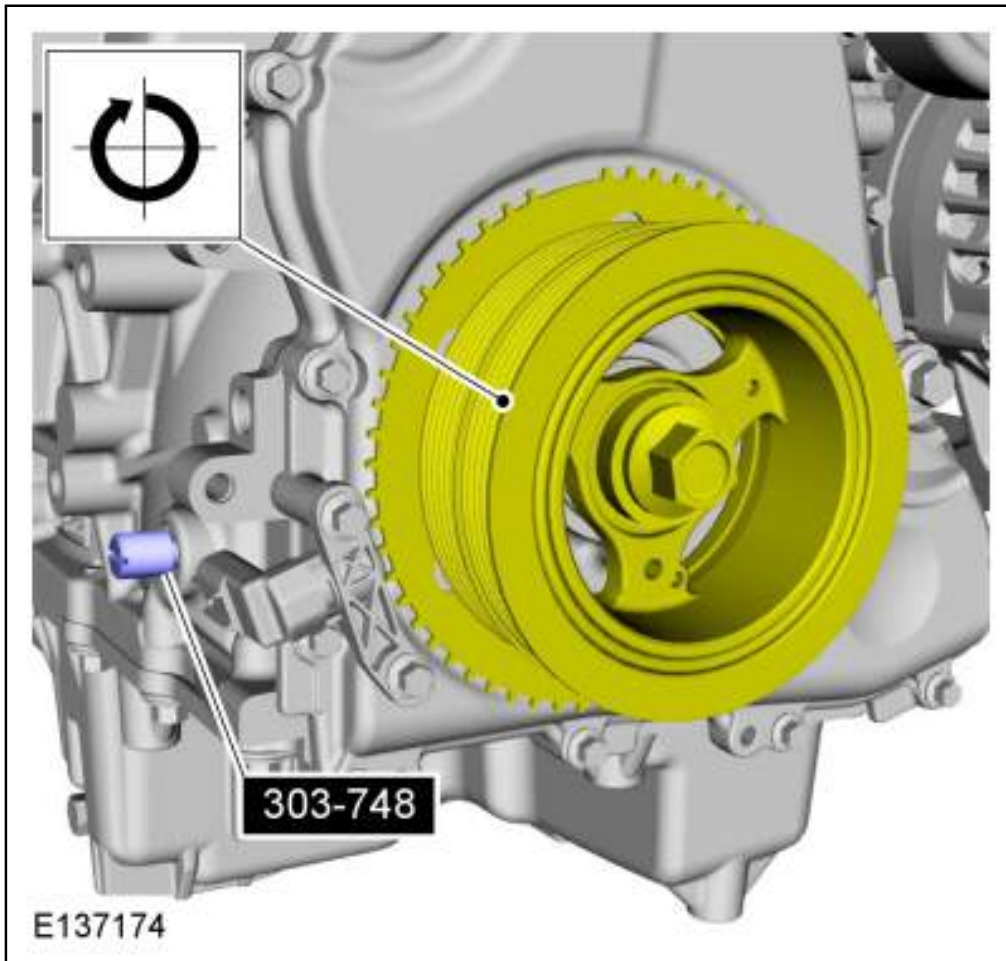

9. **NOTE:** *The special tool can only be installed if the valve timing is correct.*

Install Special Service Tool: 303-1565 Alignment Tool, Camshaft.

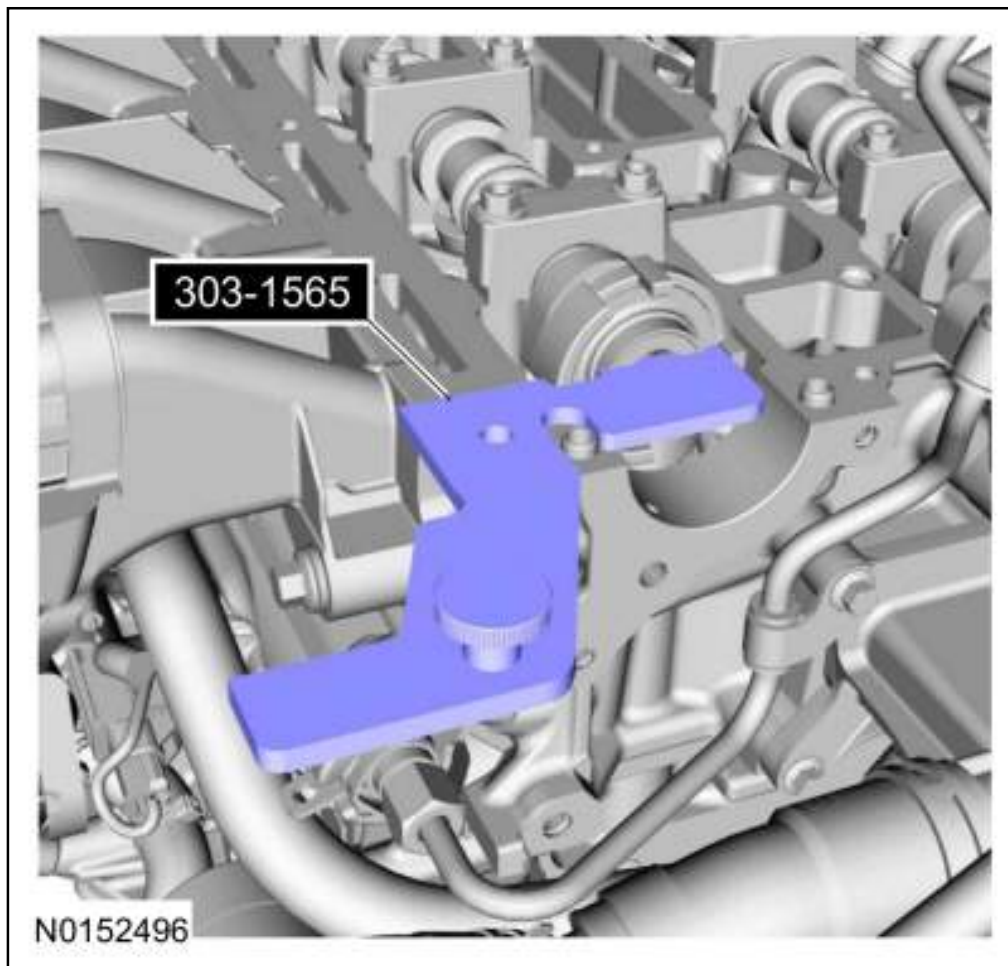

10. Remove Special Service Tool: 303-1565 Alignment Tool, Camshaft.

11.

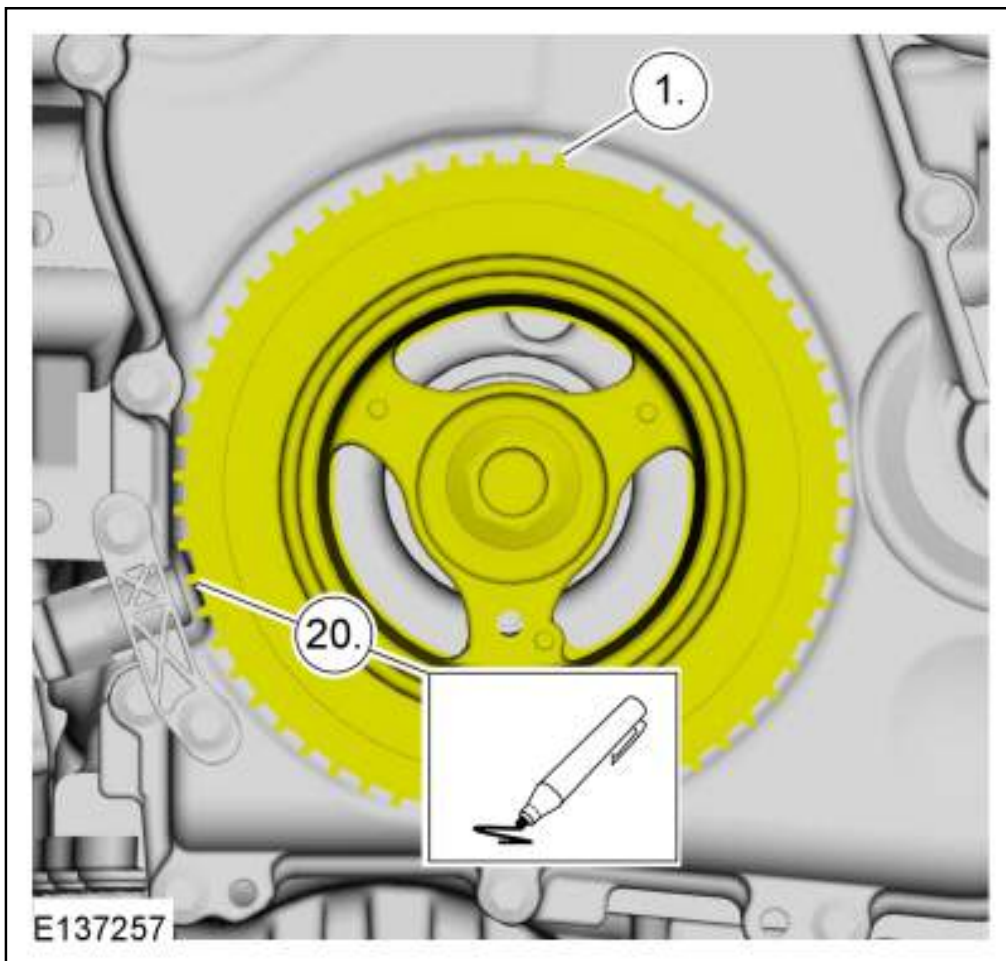

12. Loosen: 1 turn(s)

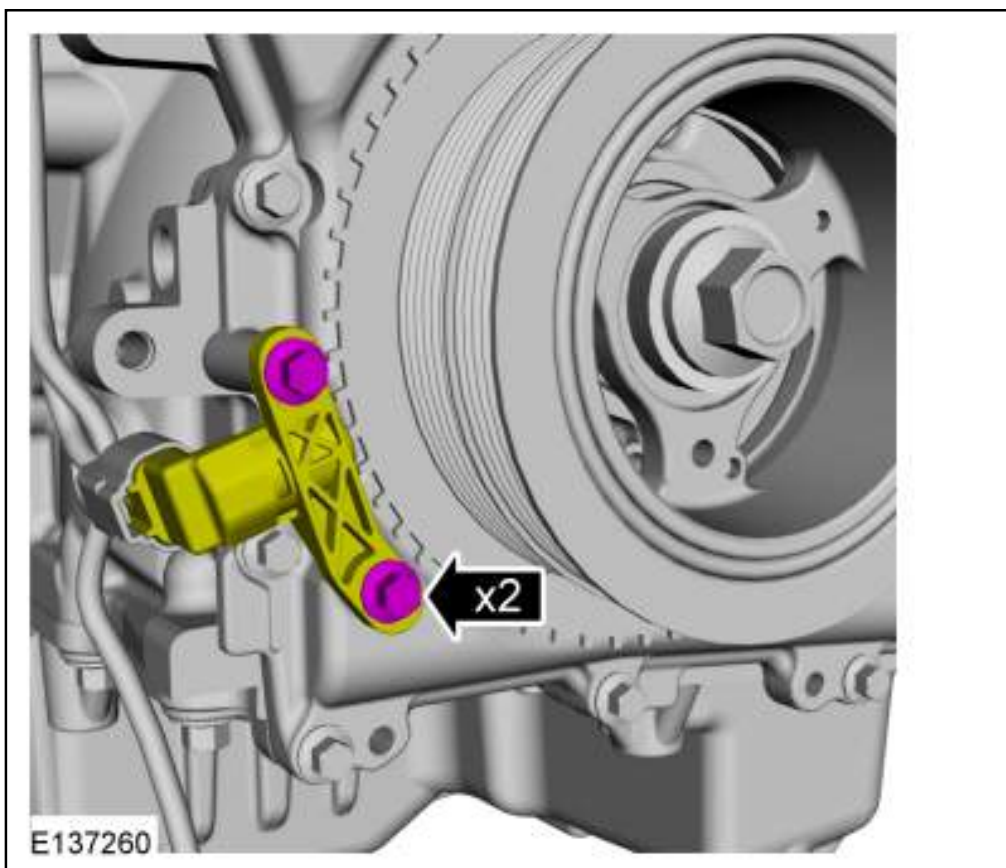

1. Install Special Service Tool: 303-1521 Alignment Tool, Crankshaft Position Sensor.
2. **NOTICE: Make sure that the component aligns with the installation mark.**

3. *Torque*: 62 lb.in (7 Nm)

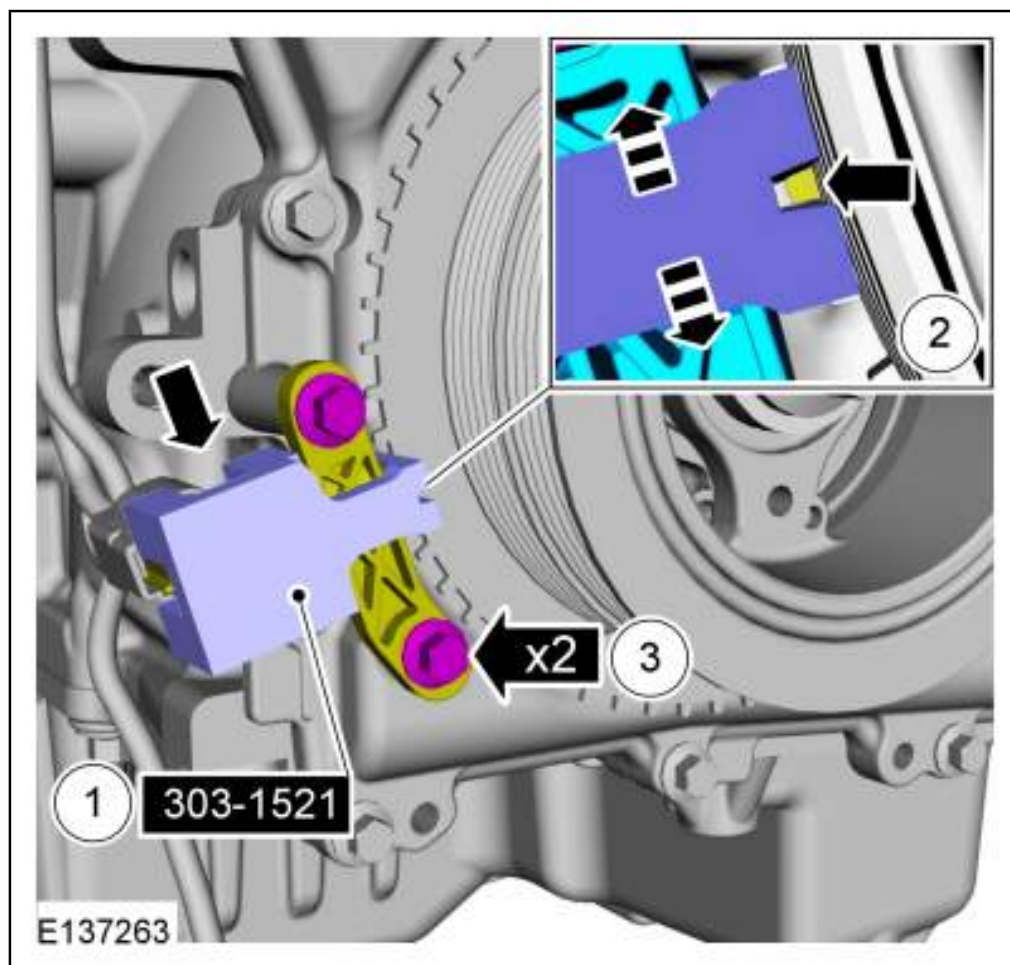

14. Remove Special Service Tool: 303-1521 Alignment Tool, Crankshaft Position Sensor.

1. Remove Special Service Tool: 303-748 Locking Tool, Crankshaft.

2. *Torque*: 177 lb.in (20 Nm)

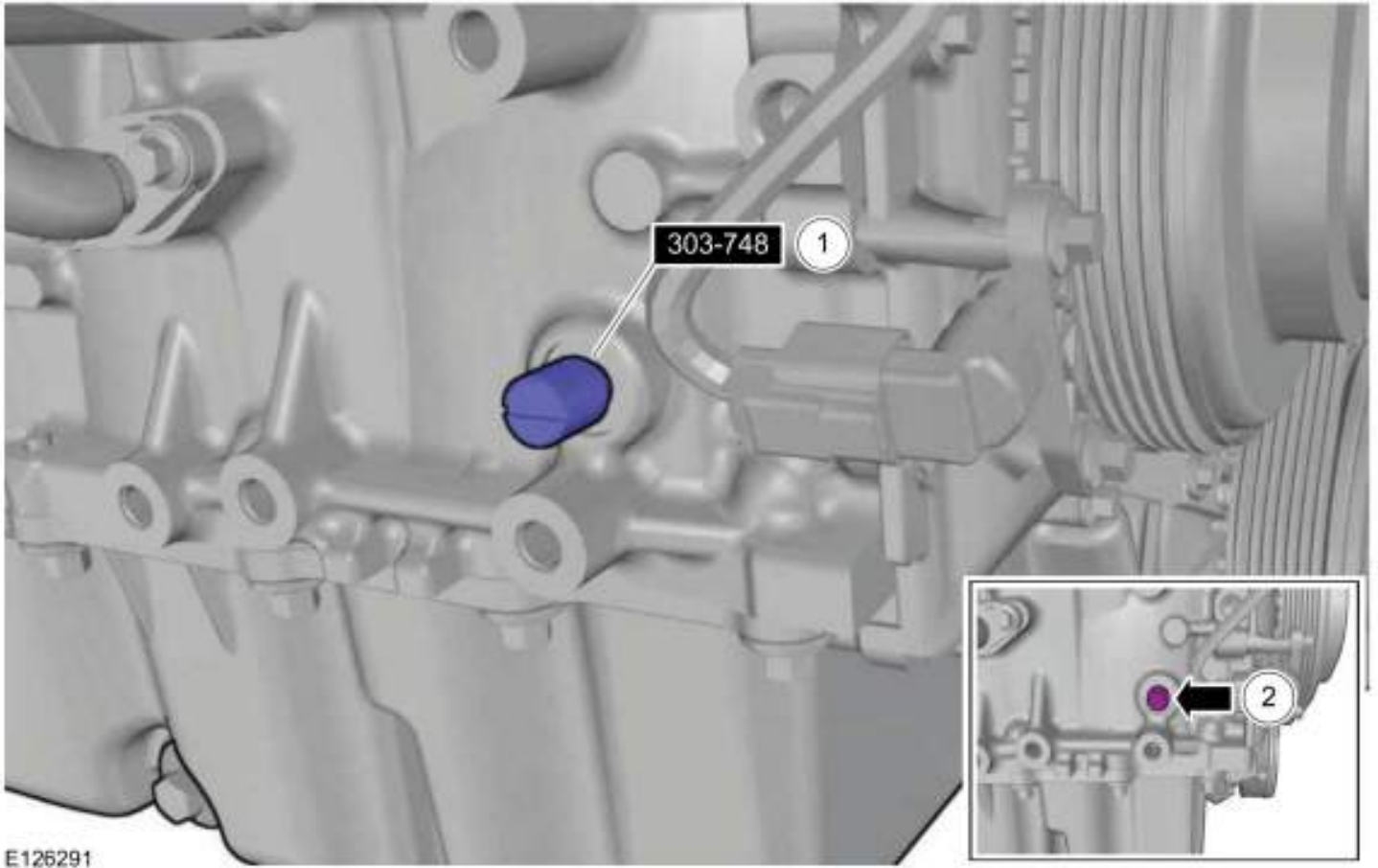

16. **NOTICE:** Use an open-ended wrench to prevent the component from turning.

*Torque:* 46 lb.ft (63 Nm)



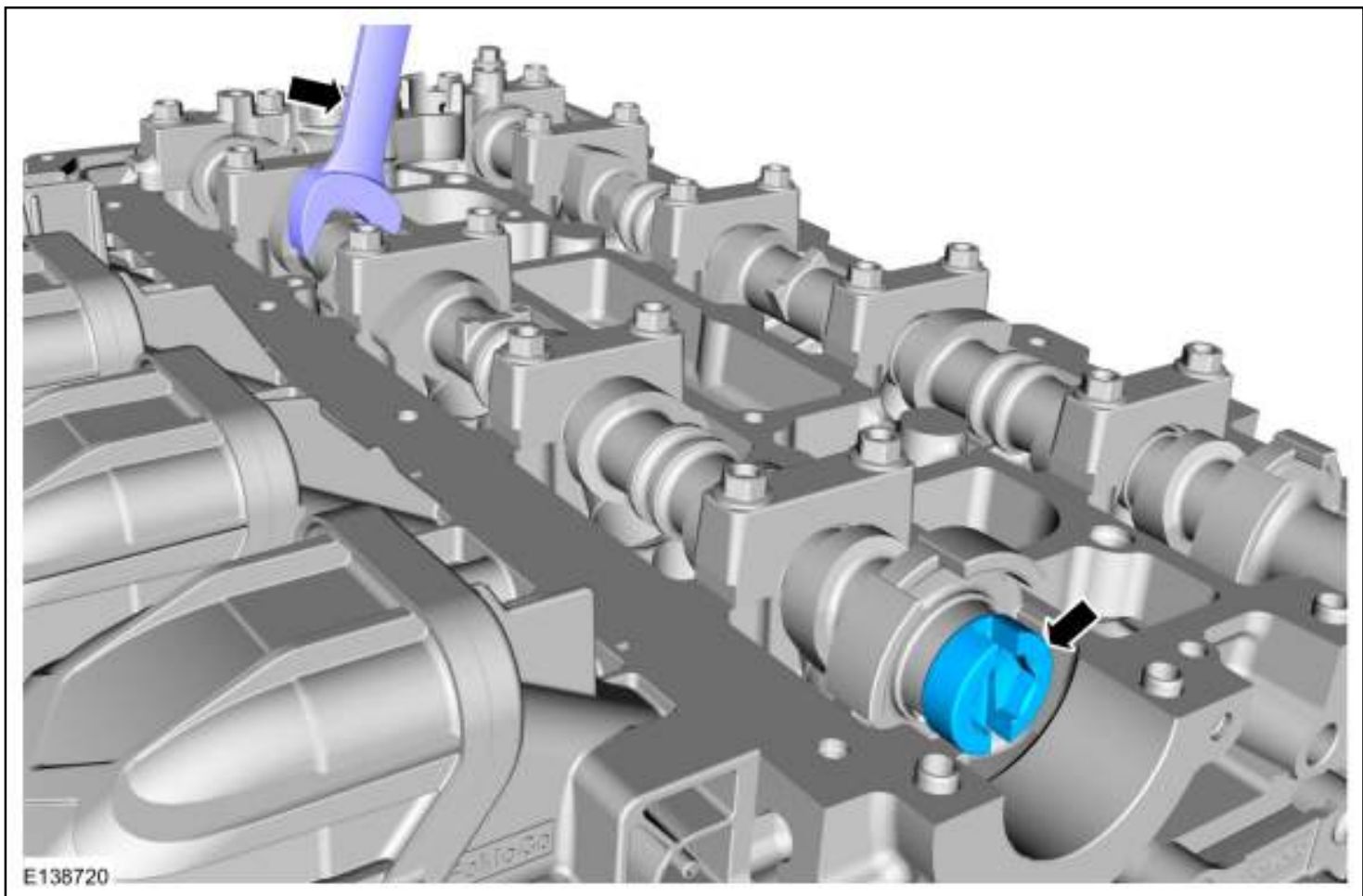

17. **NOTE:** *The component must be installed within 5 minutes of applying the sealant.*

*Material: Flange Sealant / CU7Z-19B508-A (WSS-M2G348-A11)*

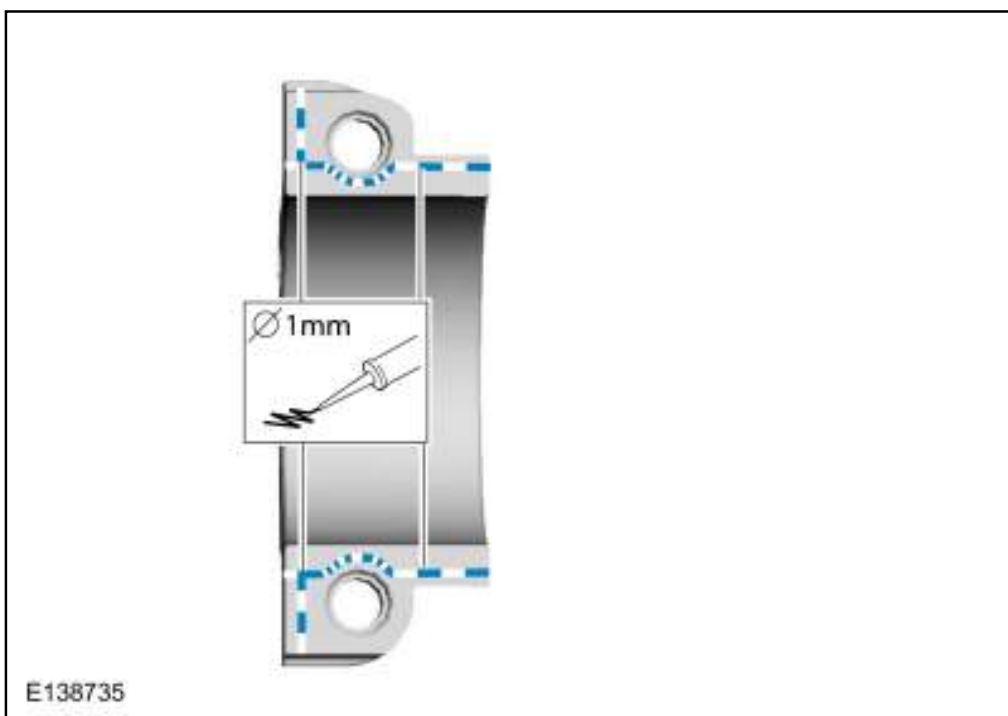

18. **Torque:**

Stage 1: 62 lb.in (7 Nm)

Stage 2: 142 lb.in (16 Nm)

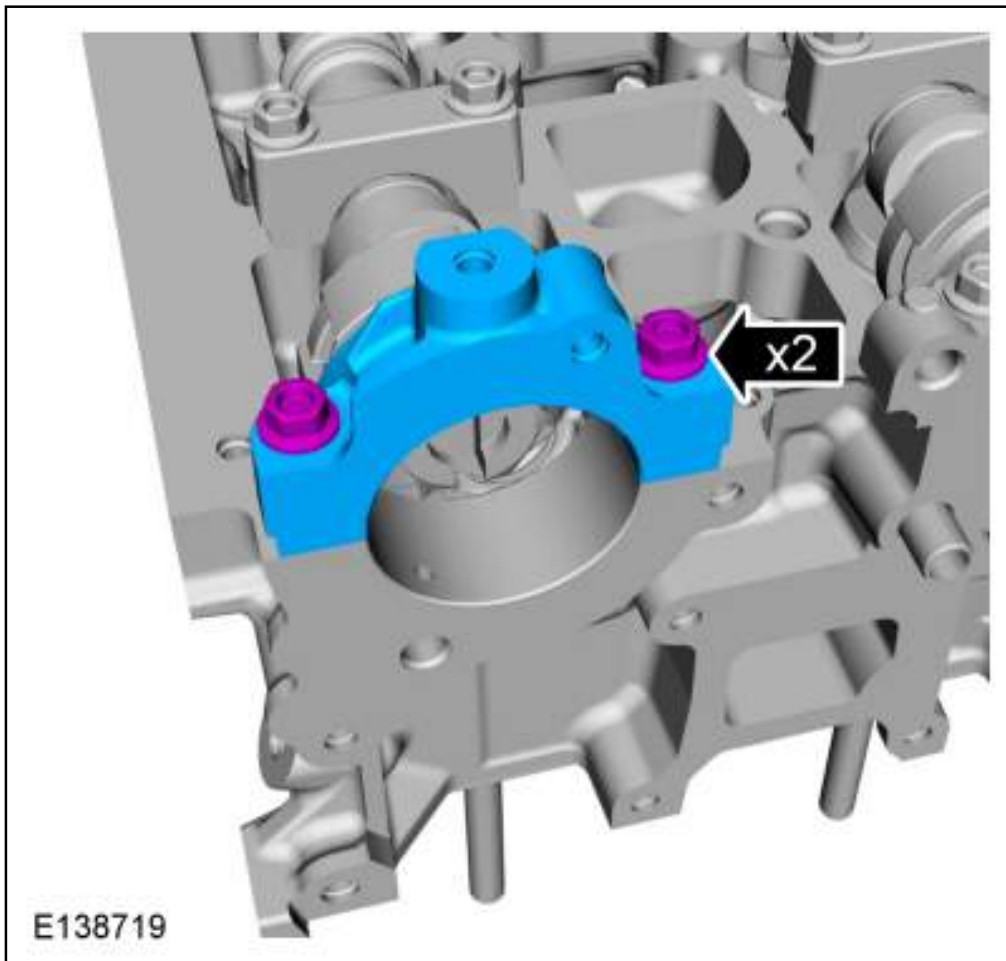

19. Install the following items:

1. Refer to: Accessory Drive Belt (303-05 Accessory Drive - 2.3L EcoBoost (257kW/350PS) - MI4) .
2. Refer to: Brake Vacuum Pump - 2.3L EcoBoost (257kW/350PS) - MI4 (206-07 Power Brake Actuation) .
3. Refer to: [Valve Cover](#) (303-01C Engine, Removal and Installation).

20. After completing the repairs, perform the Misfire Monitor Neutral Profile Correction procedure.



# Cylinder Head

Base Part Number: Base Part Number: 6051

## Special Tool(s) / General Equipment

Strap Wrench
--------------

Fluid Container
-----------------

## Materials

Name	Specification
Motorcraft® High Performance Engine RTV Silicone TA-357	WSE-M4G323-A6

## Removal

**NOTE:** Removal steps in this procedure may contain installation details.

1. Remove the following items:
  1. Refer to: Cowl Panel Grille (501-02 Front End Body Panels) .
  2. Refer to: [Intake Manifold](#) (303-01C Engine, Removal and Installation).
  3. Refer to: [Camshafts](#) (303-01C Engine, Removal and Installation).
2. Refer to: Cooling System Draining, Vacuum Filling and Bleeding (303-03 Engine Cooling - 2.3L EcoBoost (257kW/350PS) - MI4) .
3. **NOTE:** Be prepared to collect escaping fluid.

**NOTE:** The oil drain plug with O-ring seal is to be reused unless damaged.

Use the General Equipment: Fluid Container  
Torque: 21 lb.ft (28 Nm)

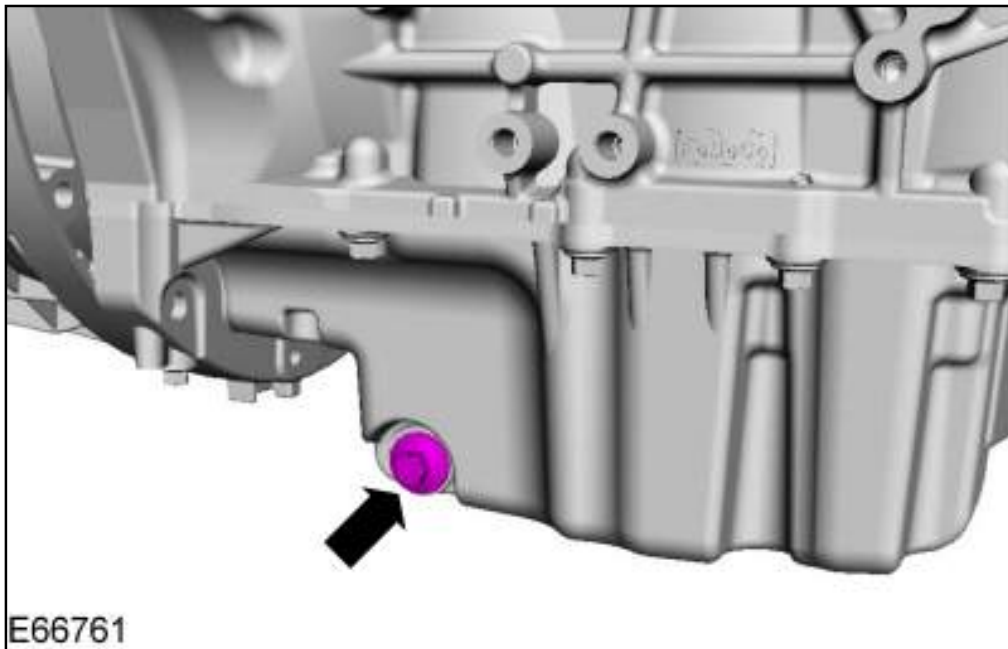

4. Use the General Equipment: Fluid Container  
Use the General Equipment: Strap Wrench

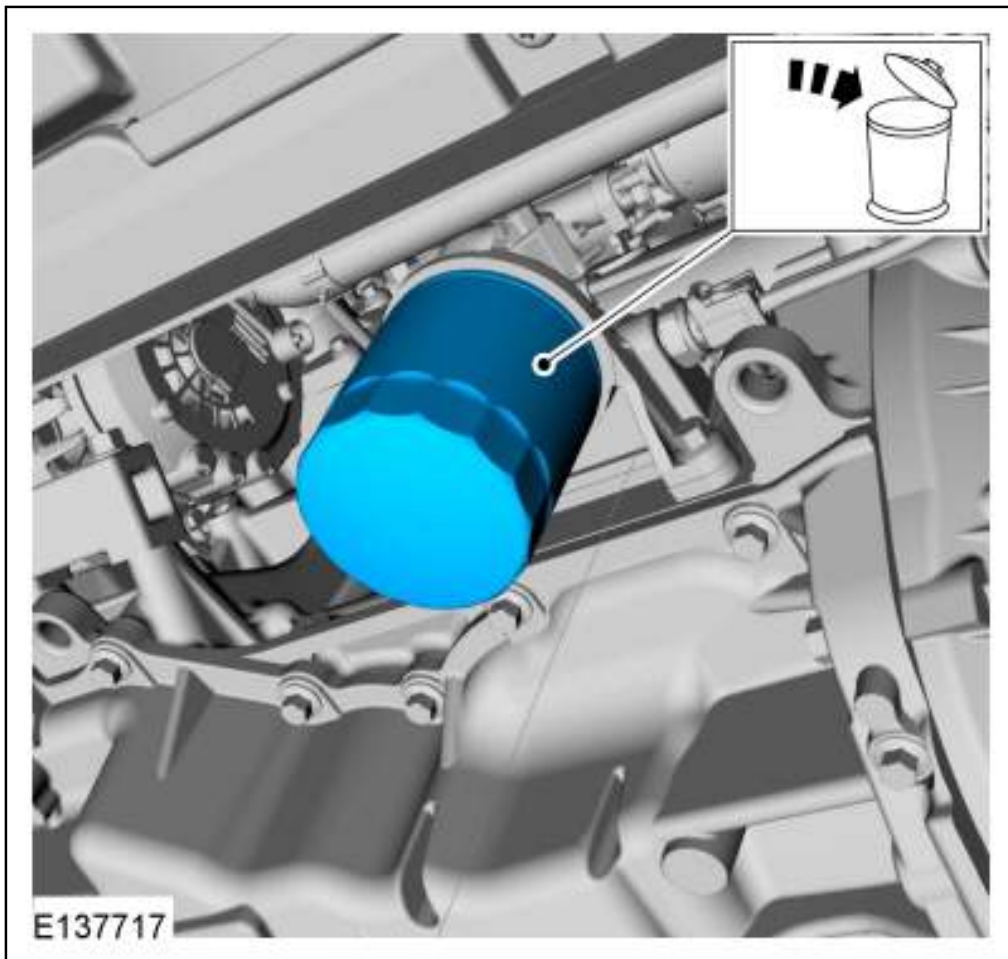

5. **NOTE:** Make sure that new nuts are installed.

*Torque: 37 lb.ft (50 Nm)*

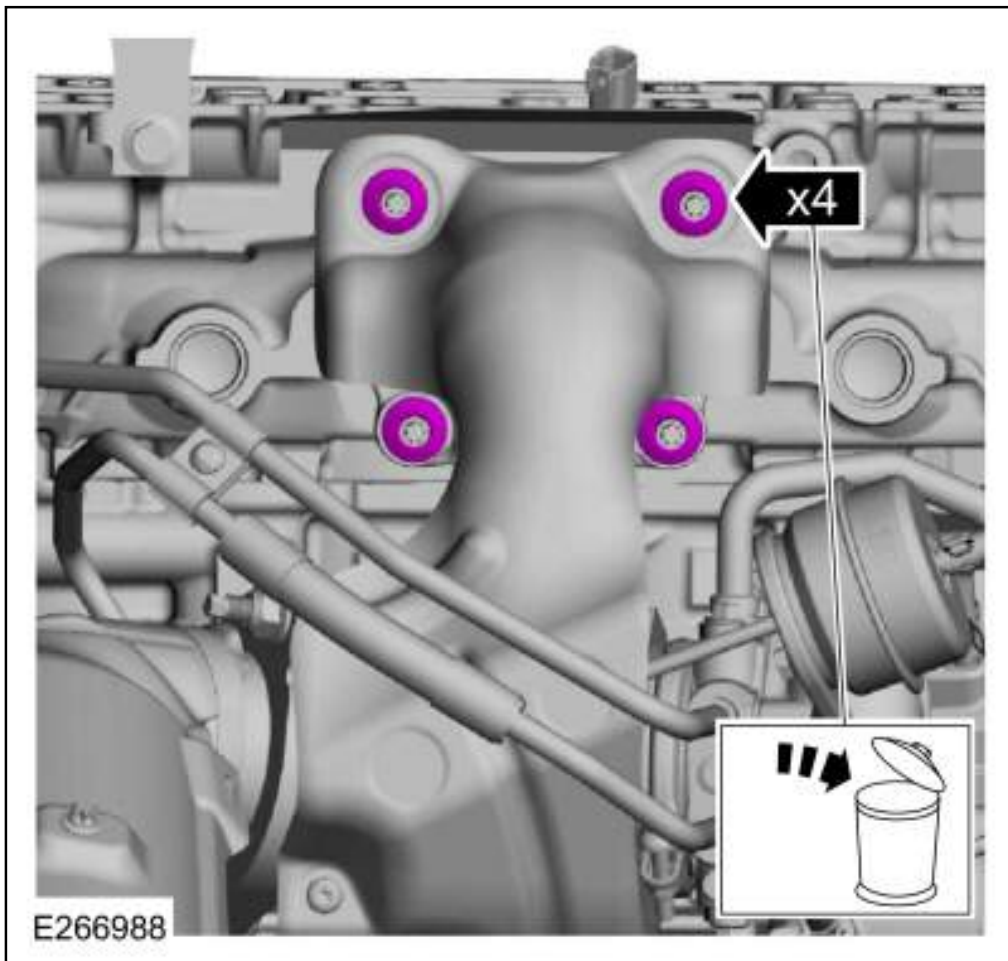

6. **NOTE:** Make sure that new studs are installed.

*Torque:* 150 lb.in (17 Nm)

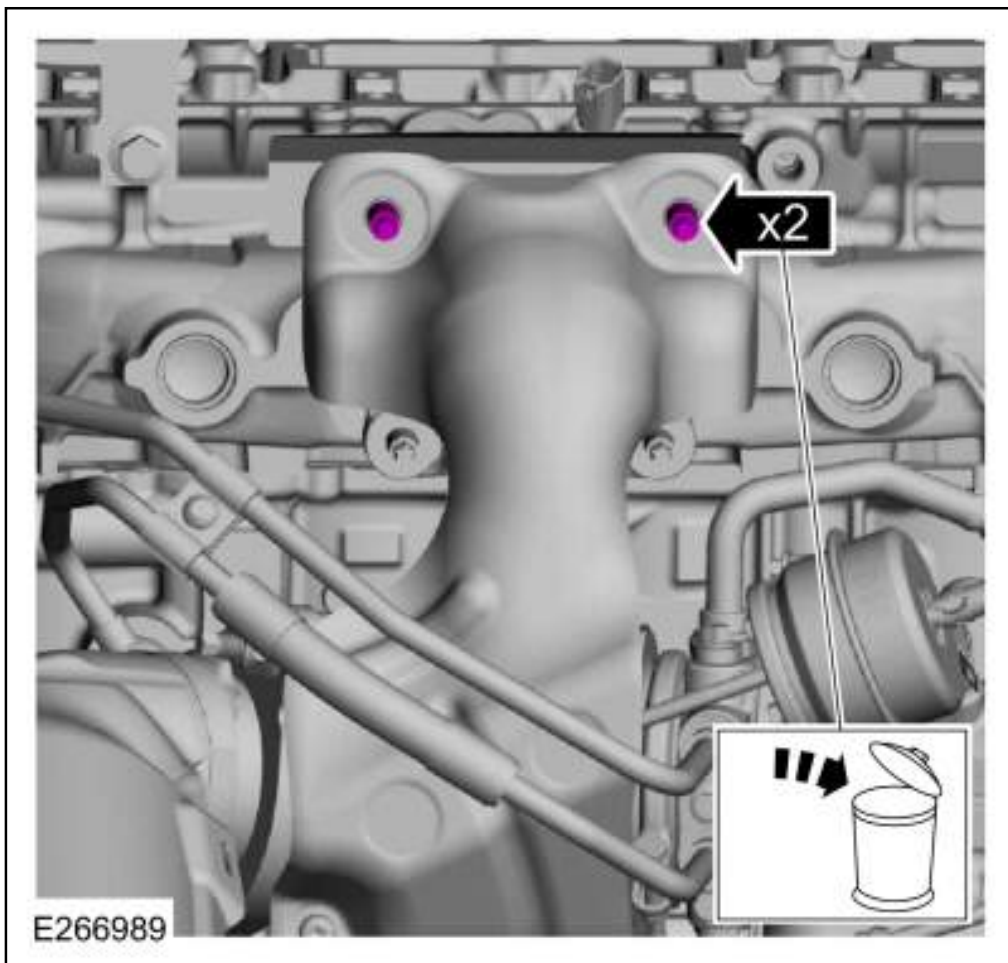

7.

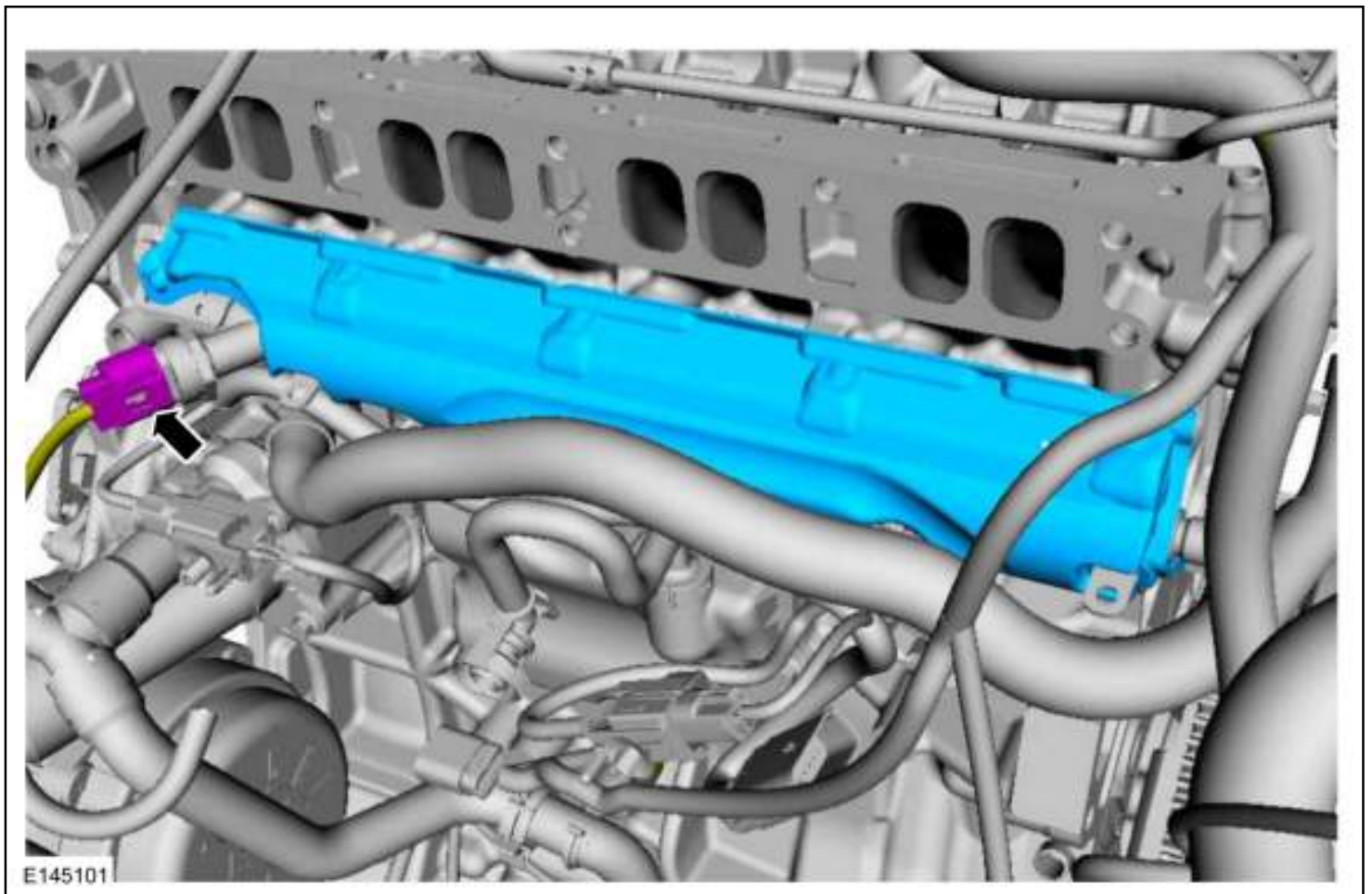

8.

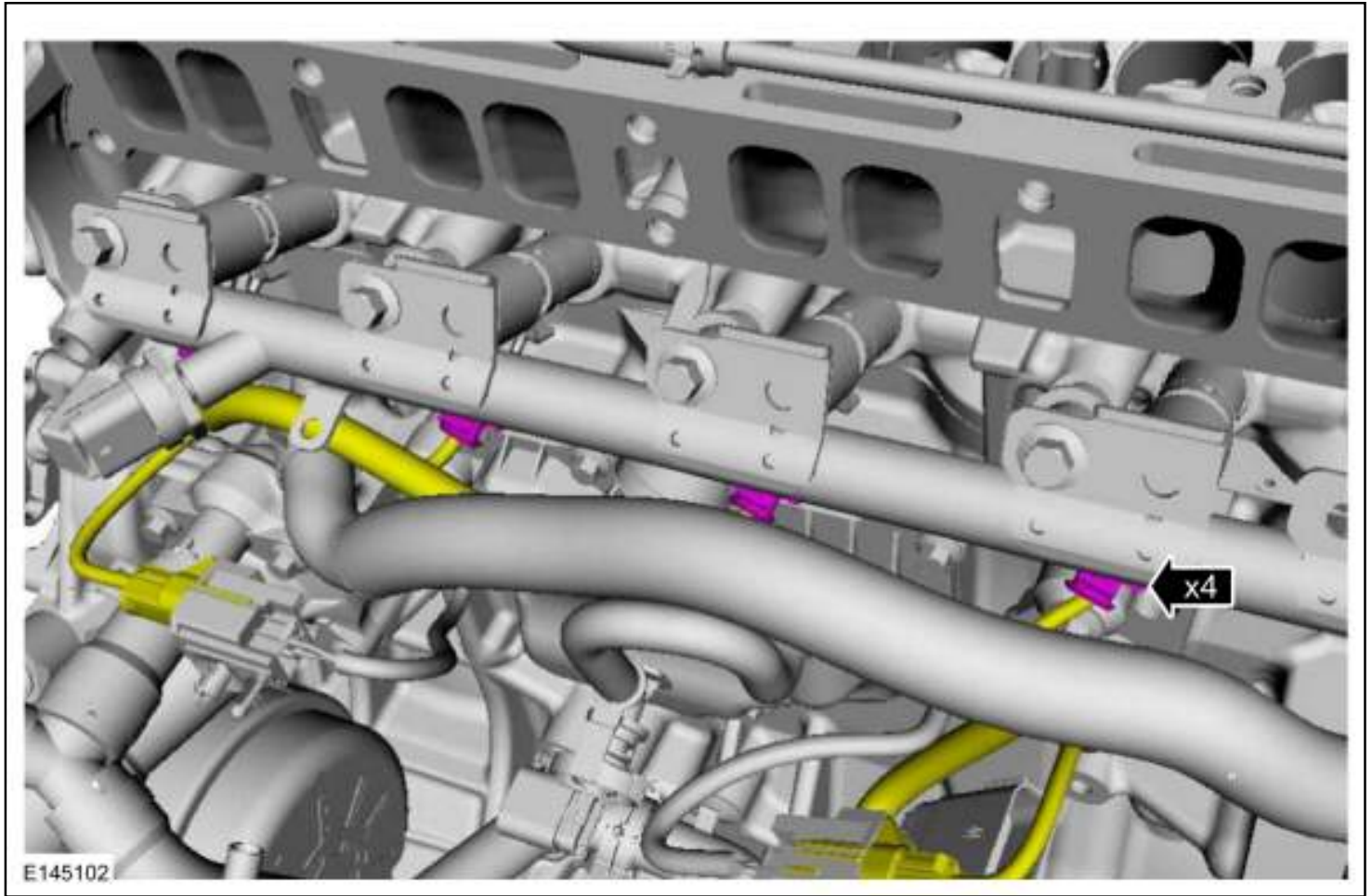

9. *Torque:* 106 lb.in (12 Nm)

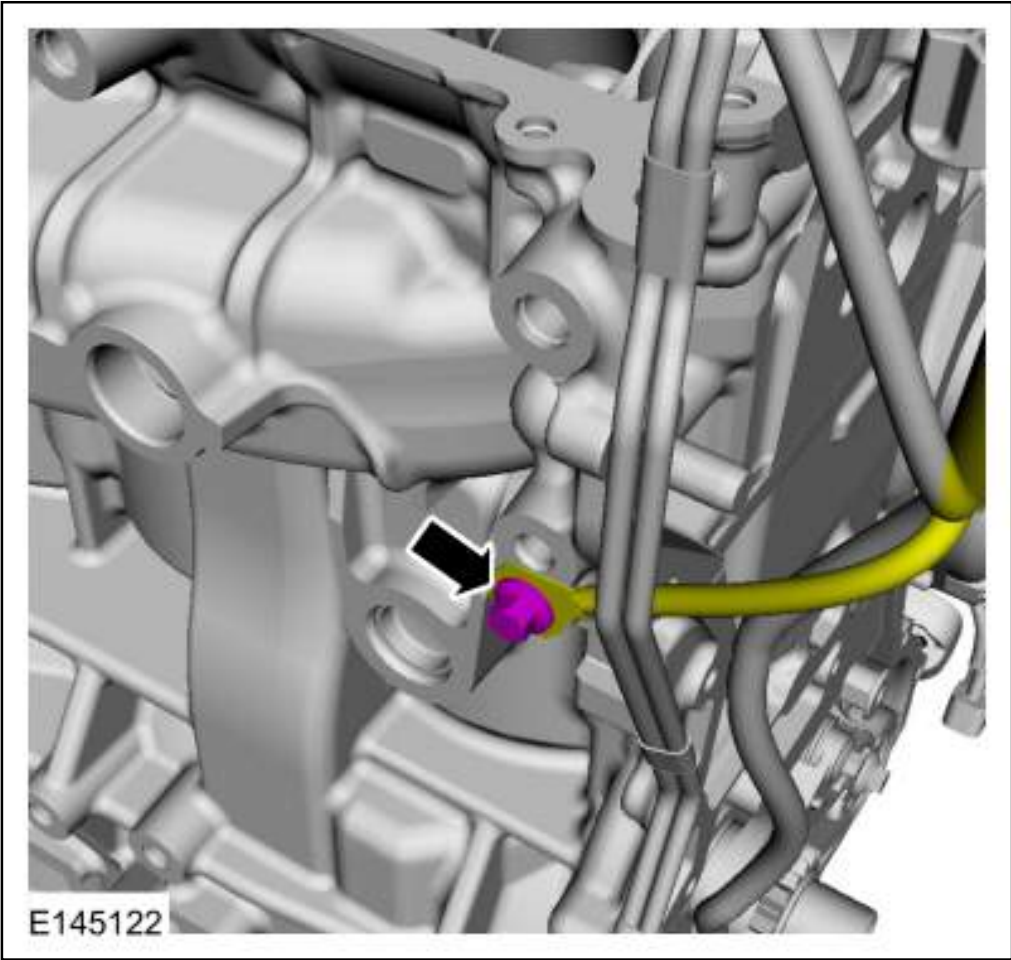

10.

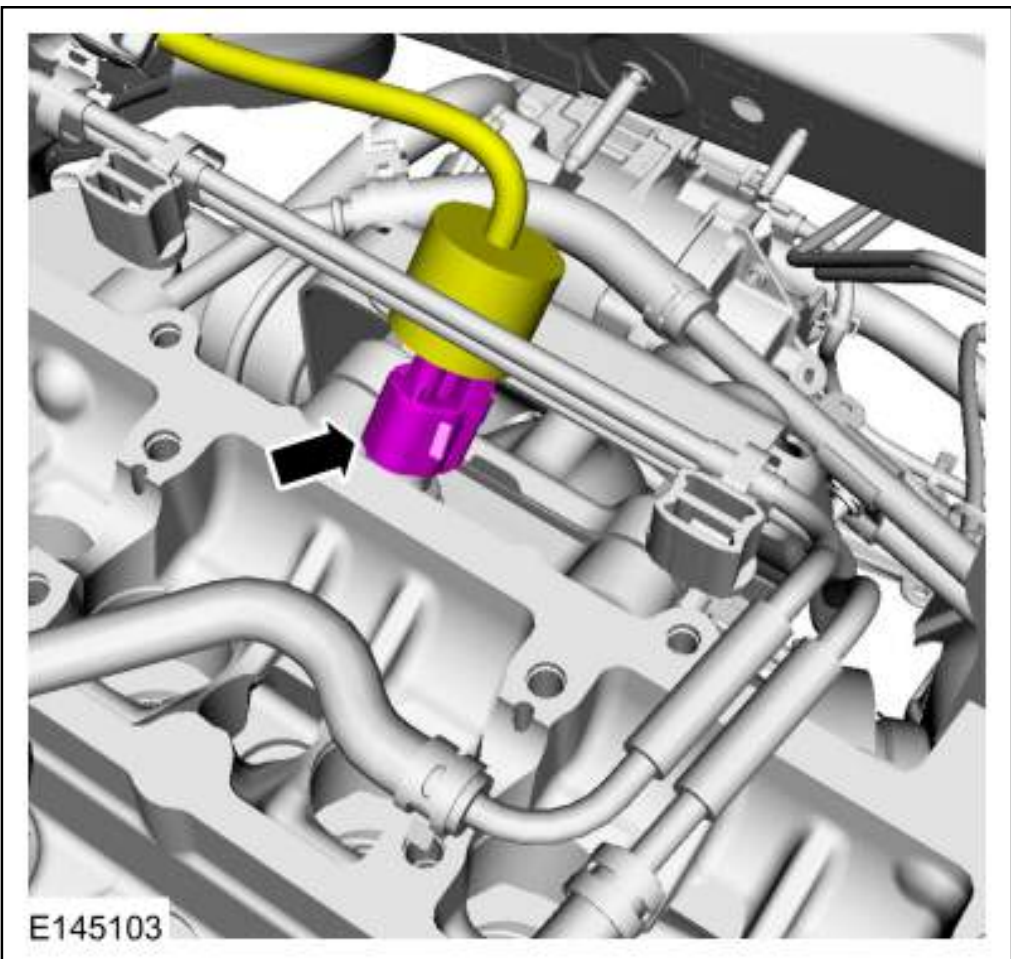

11. *Torque:* 89 lb.in (10 Nm)

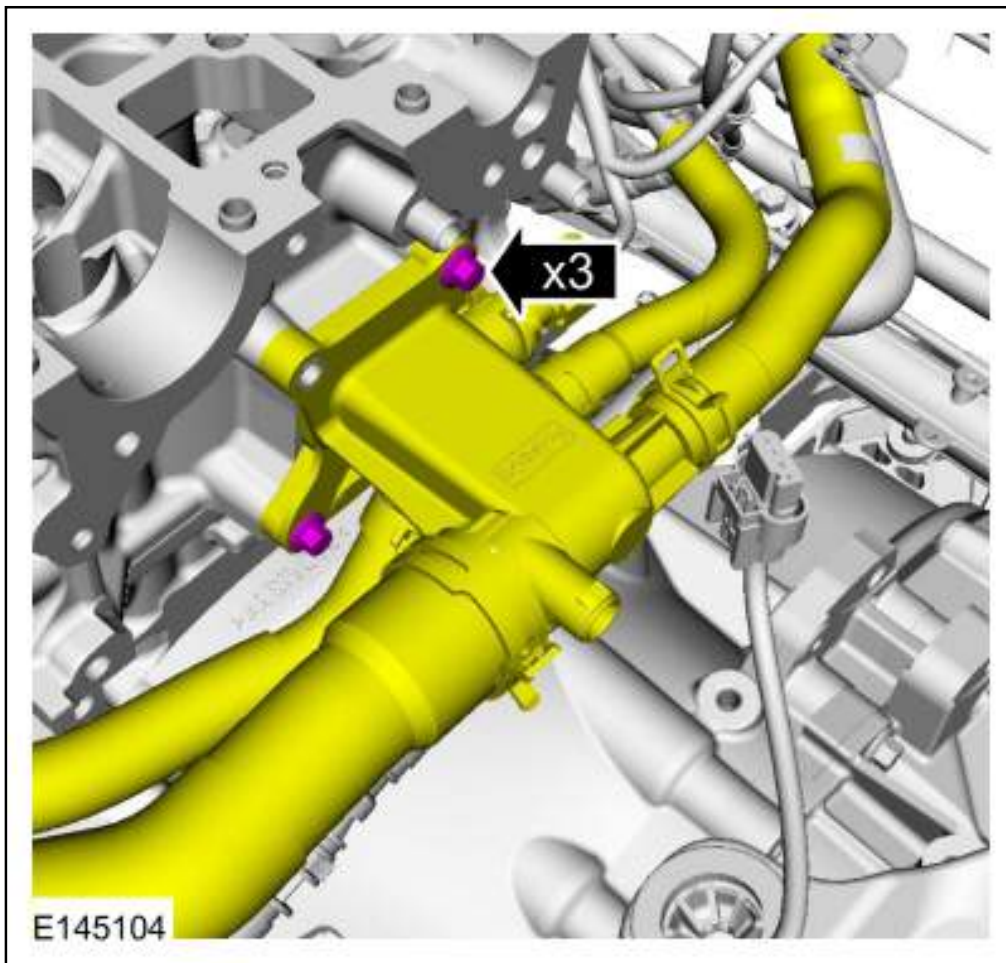

12. **NOTE:** *Note the position of the component before removal.*

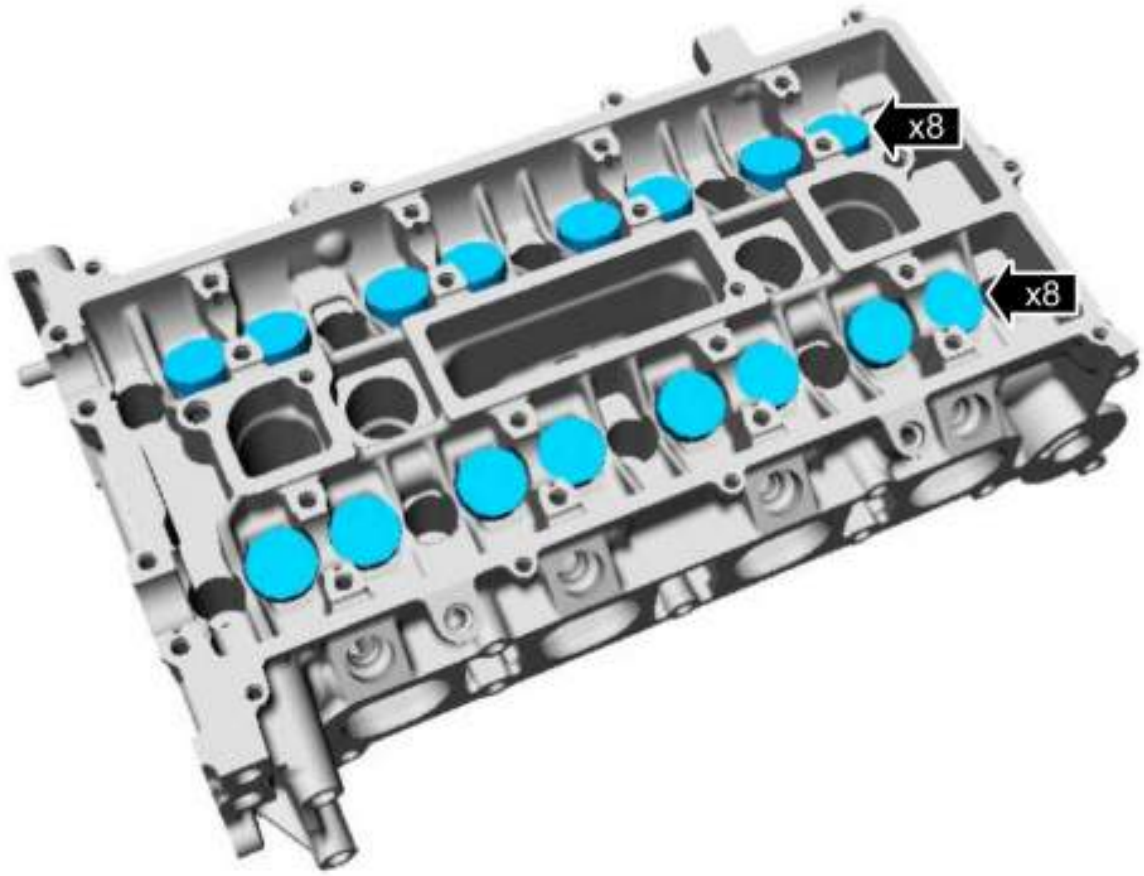

E66111



13.

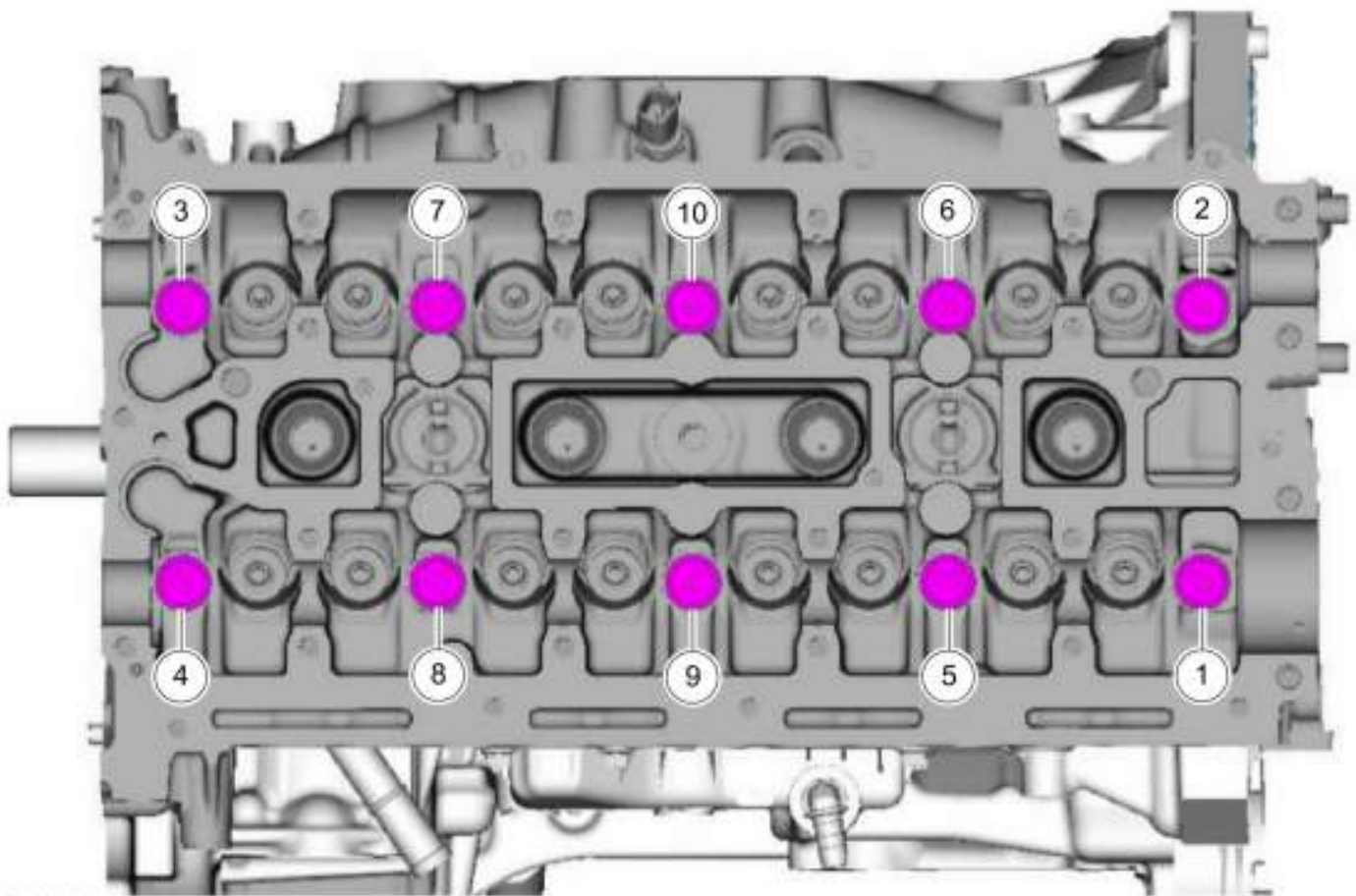

E266990



14. **NOTE:** This step requires the aid of another technician.

**NOTE:** Make sure that the components are not damaged.

 [Click here to view a video version of this procedure.](#)

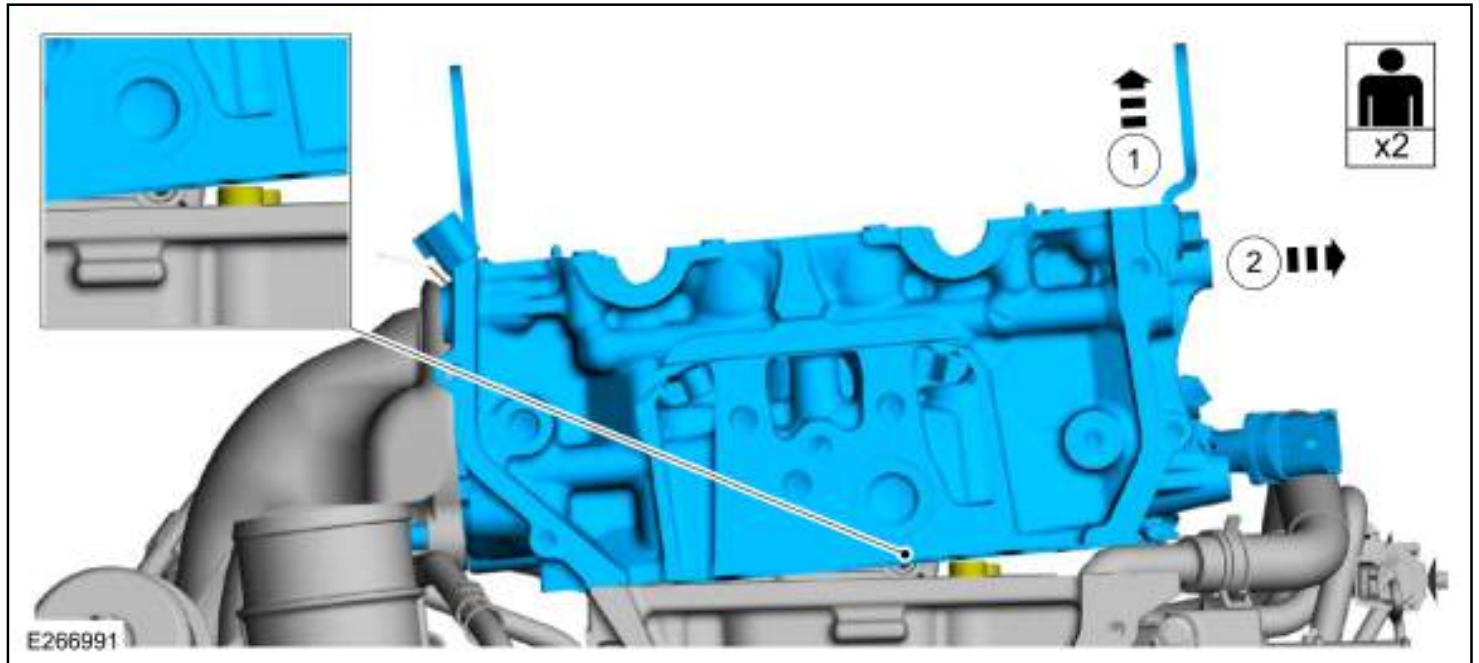

15.

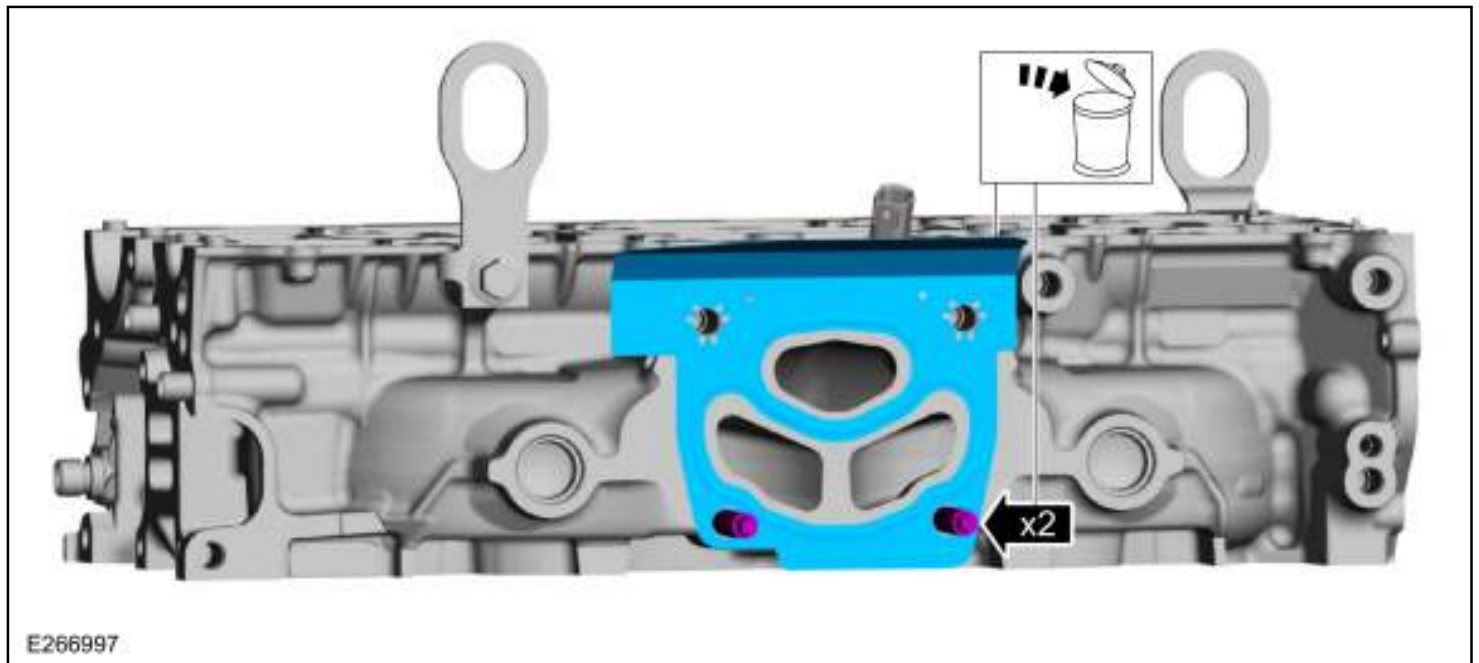

16.



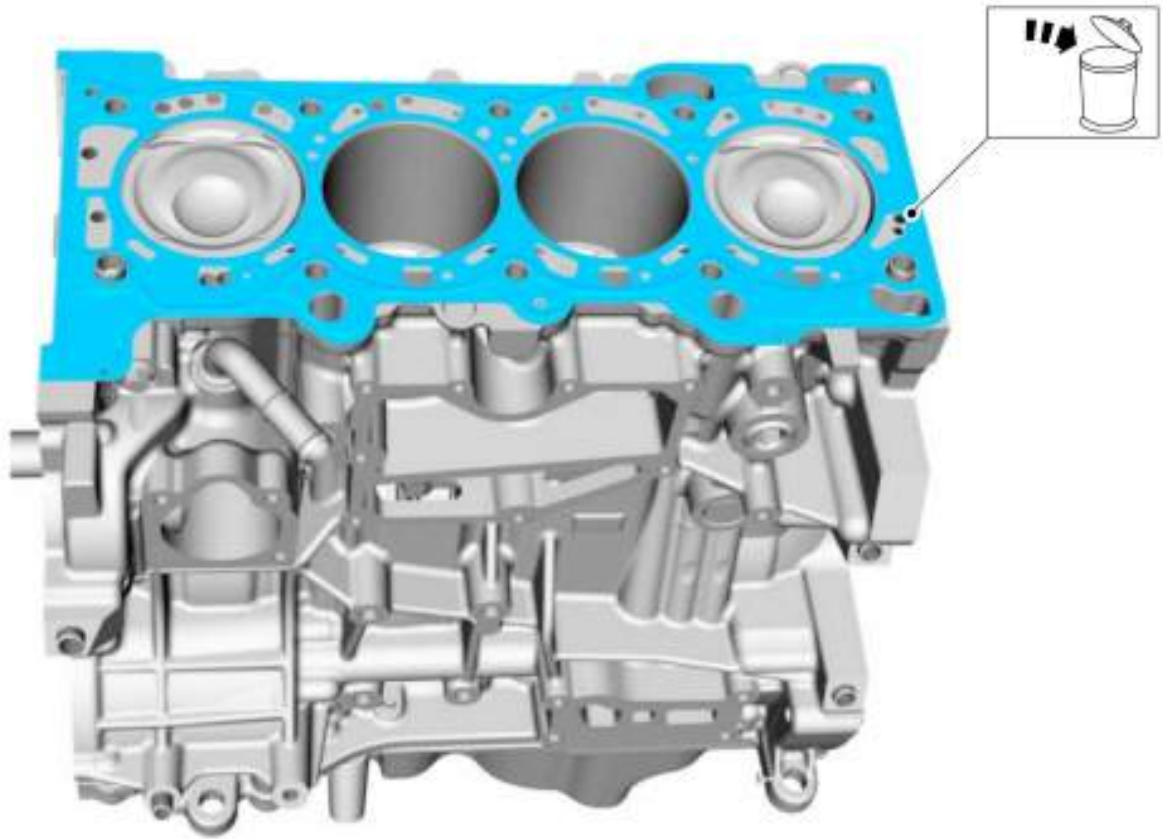

N0152208



cardiagn.com

## Installation

1. To install, reverse the removal procedure.
2. **NOTE:** *Make sure that the mating faces are clean and free of foreign material.*

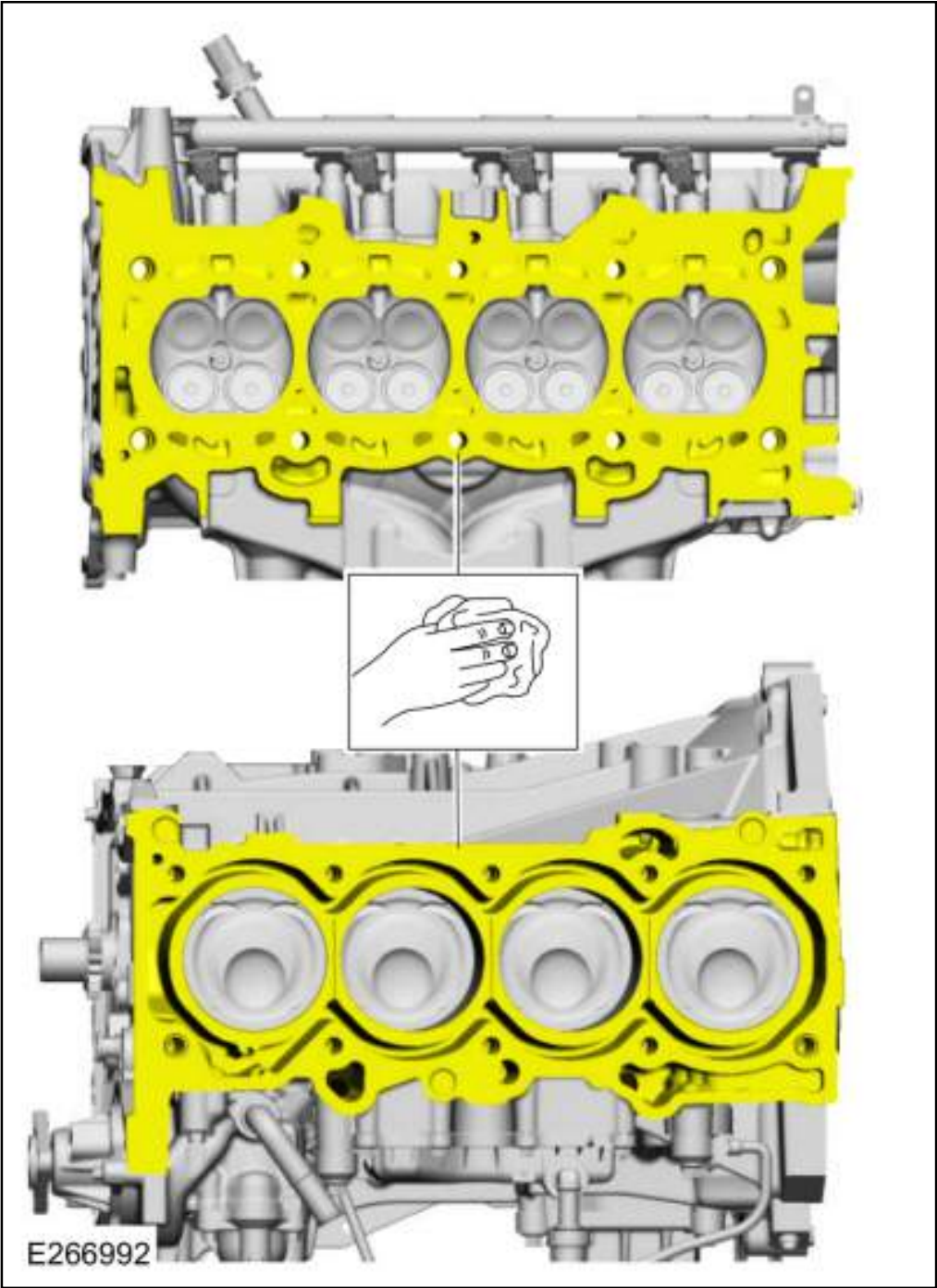

3.

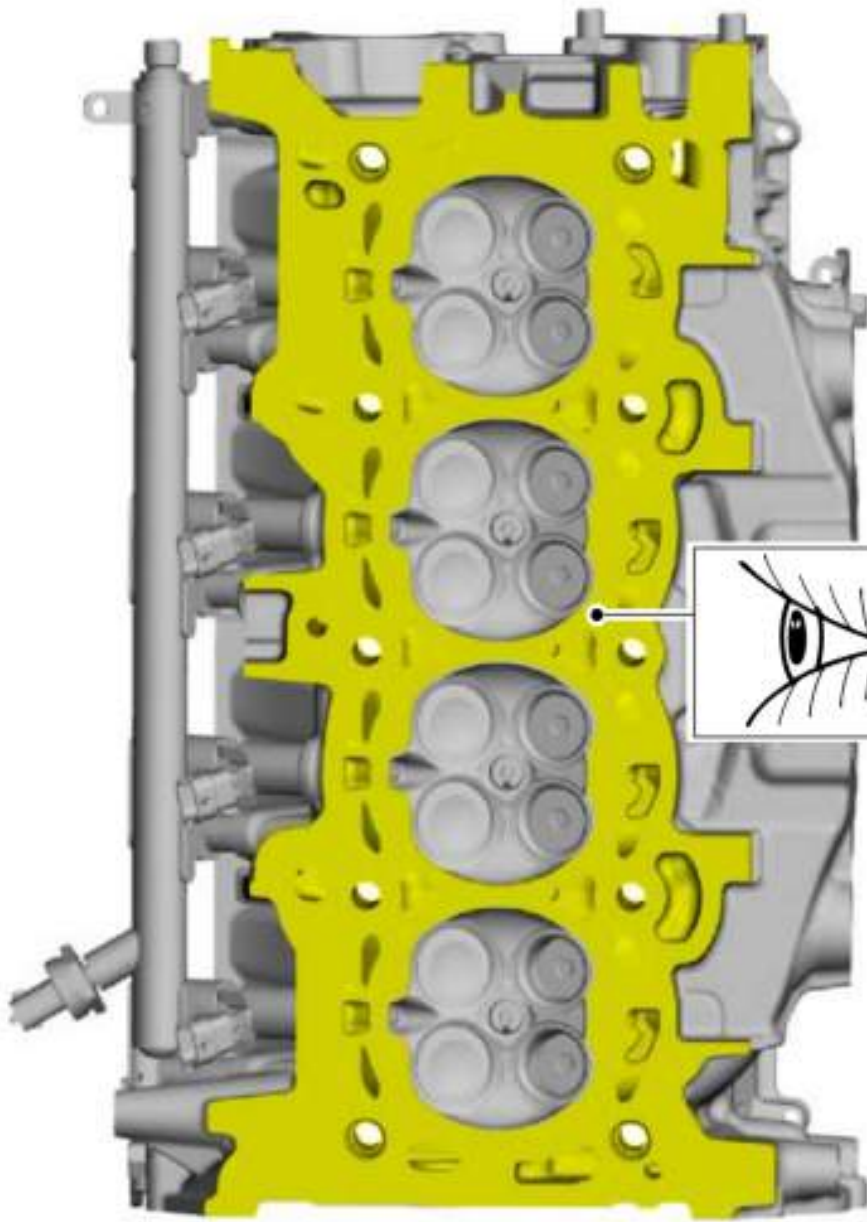

E266993



4. *Torque:* 150 lb.in (17 Nm)

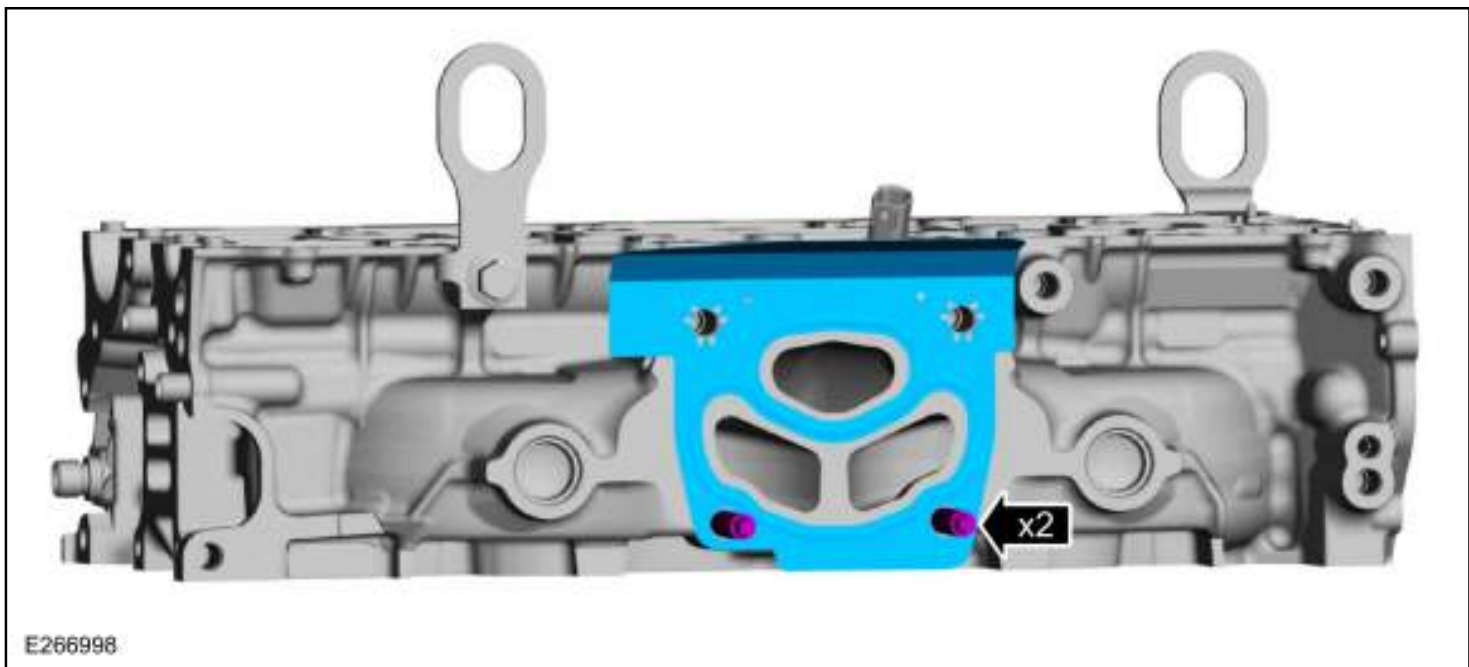

5.



6. **NOTE:** *The component must be installed within 10 minutes of applying the sealant.*

Apply a drop of sealant at positions shown.

*Material:* Motorcraft® High Performance Engine RTV Silicone / TA-357 (WSE-M4G323-A6)

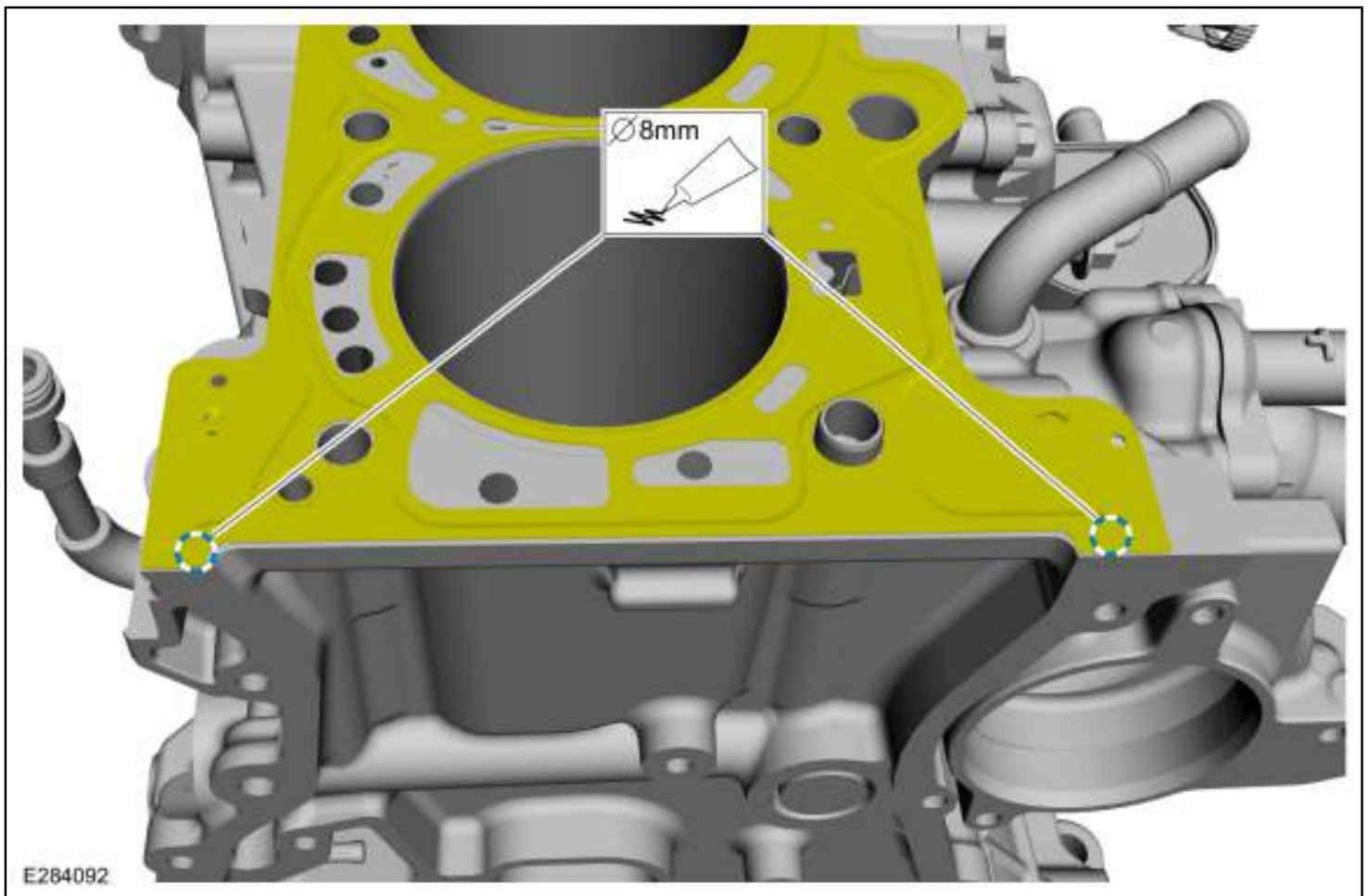

7. **NOTE:** *This step requires the aid of another technician.*

**NOTE:** *Make sure that the components are not damaged.*

[Click here to view a video version of this procedure.](#)

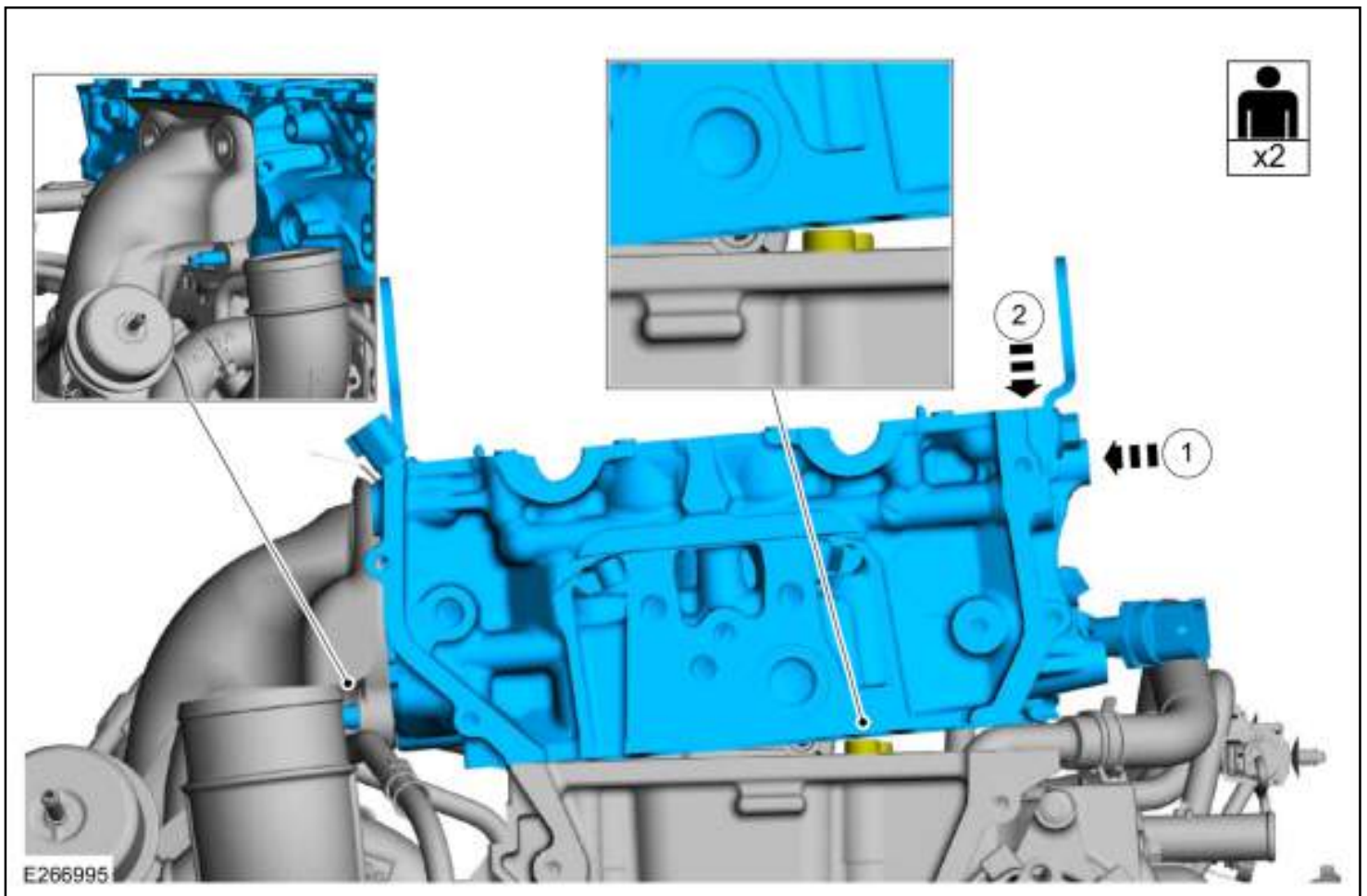

8. **NOTE:** Make sure that the mating faces are clean and free of foreign material.

*Torque:*

- Stage 1: 62 lb.in (7 Nm)
- Stage 2: 133 lb.in (15 Nm)
- Stage 3: 41 lb.ft (55 Nm)
- Stage 4: 90°
- Stage 5: 90°

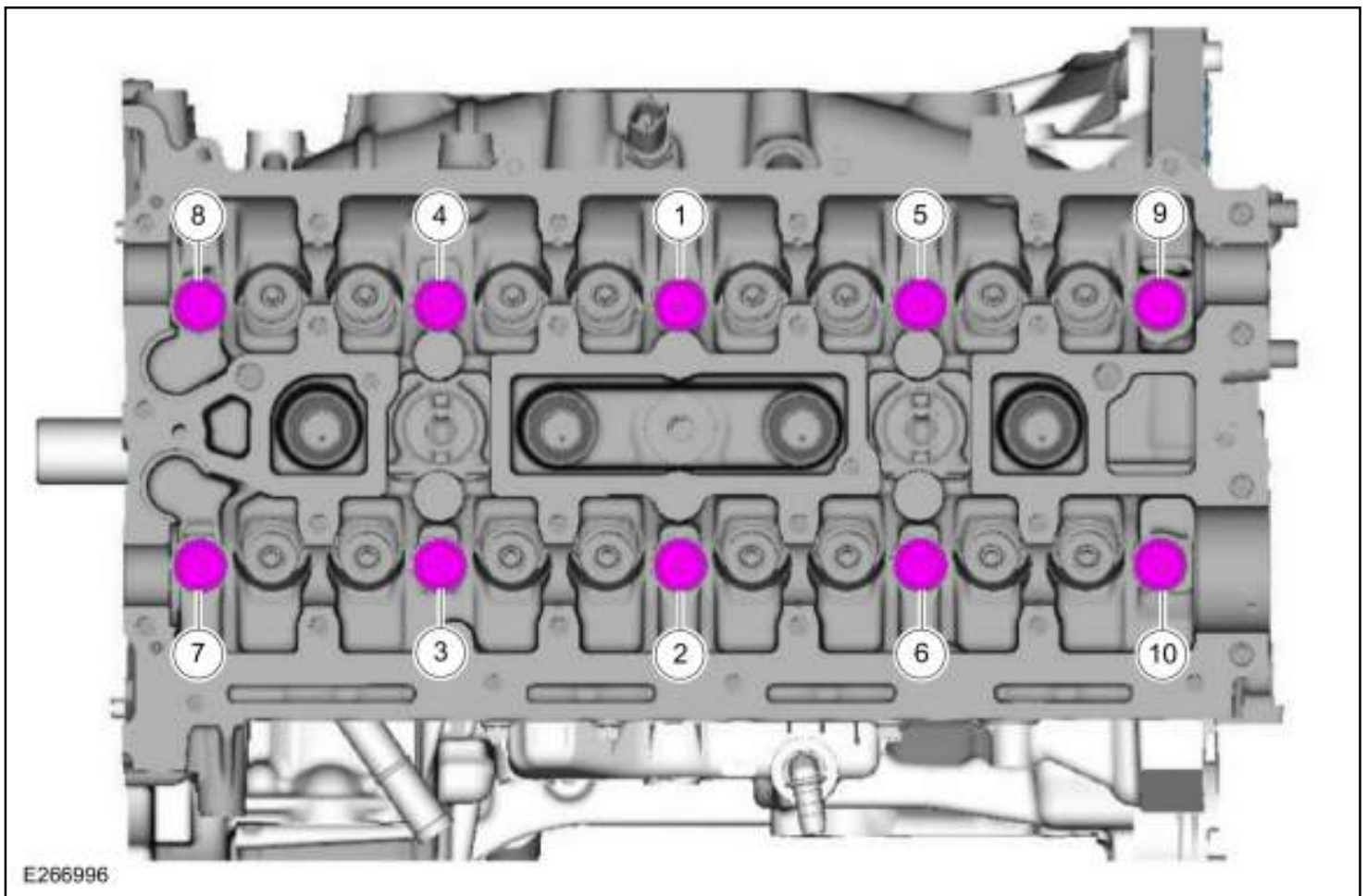

9. **NOTE:** Make sure that the components are installed to the position noted before removal.

**NOTE:** Component(s) must be lubricated with clean engine oil.



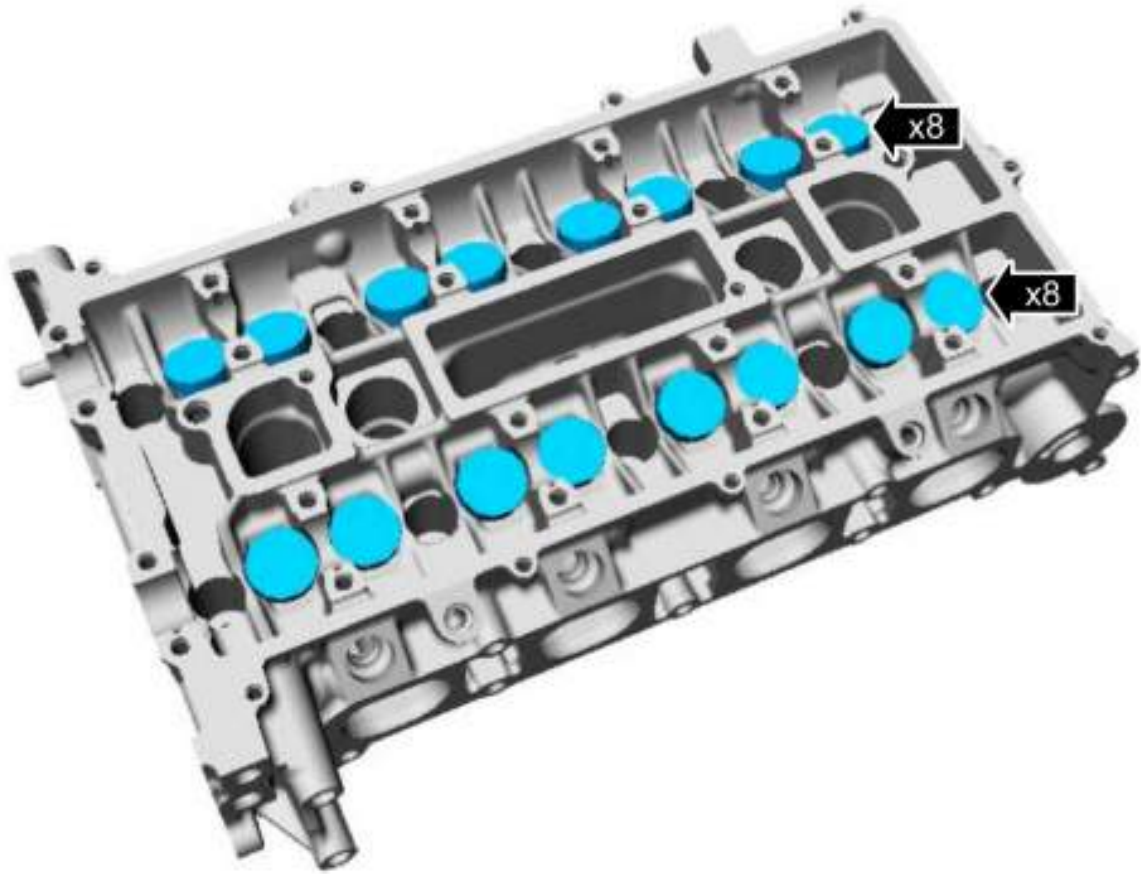

E66111

10. **NOTE:** *Component must be lubricated with clean engine oil.*

**NOTE:** *Make sure that a new component is installed.*

*Torque: 133 lb.in (15 Nm)*



cardiagn.com

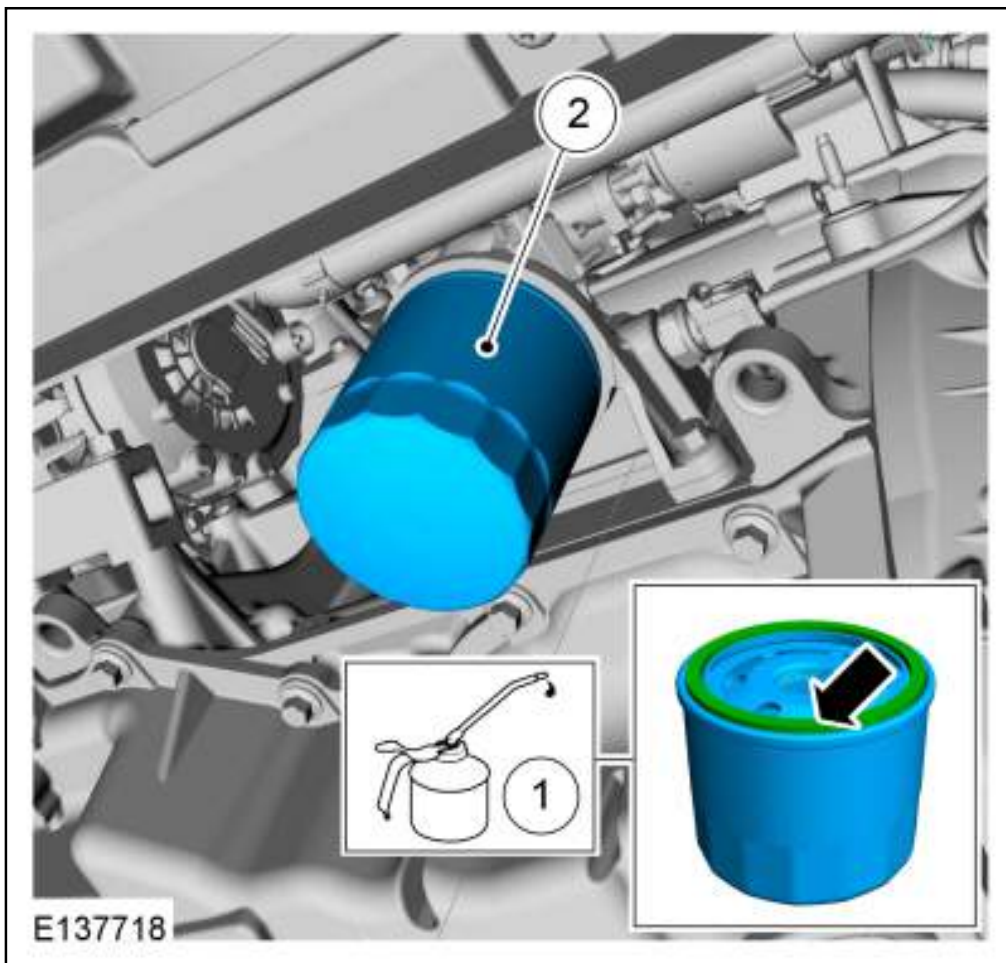

11. **NOTE:** Make sure that fluid level is to the MAX mark.

Refer to: [Specifications](#) (303-01C Engine, Specifications).

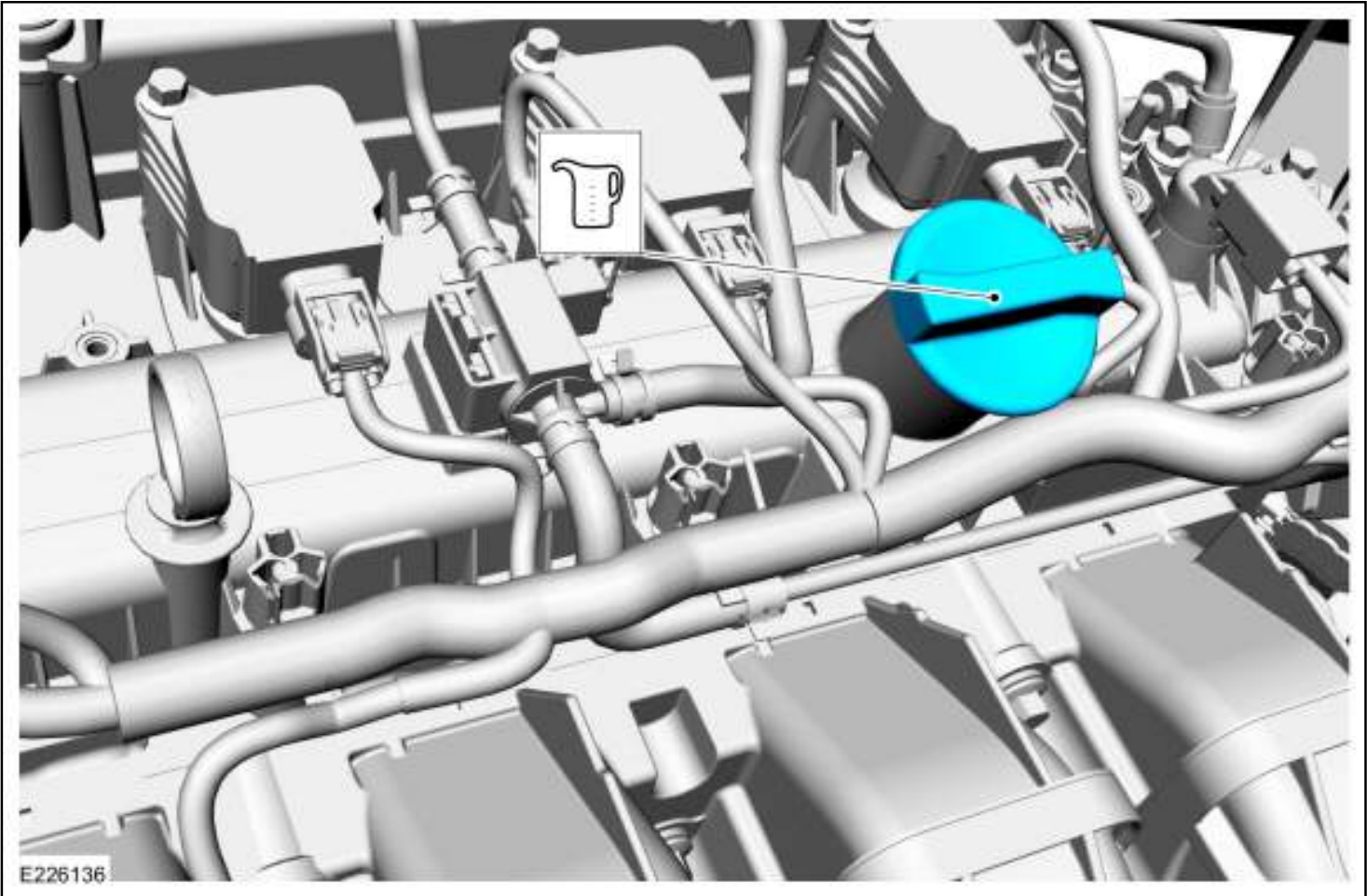

Copyright © 2019 Ford Motor Company

cardiagn.com



## Valve Cover

### Special Tool(s) / General Equipment

 14010	204-017 Installer, Wheel Hub Bearing Cup
 205080	205-080 Installer, Differential Bearing
Hose Clamp Remover/Installer	

### Materials

Name	Specification
Motorcraft® Silicone Gasket and Sealant TA-30	WSE-M4G323-A4

### Removal

**NOTE:** Removal steps in this procedure may contain installation details.

1. Refer to: Ignition Coil-On-Plug (303-07G) .
- 2.

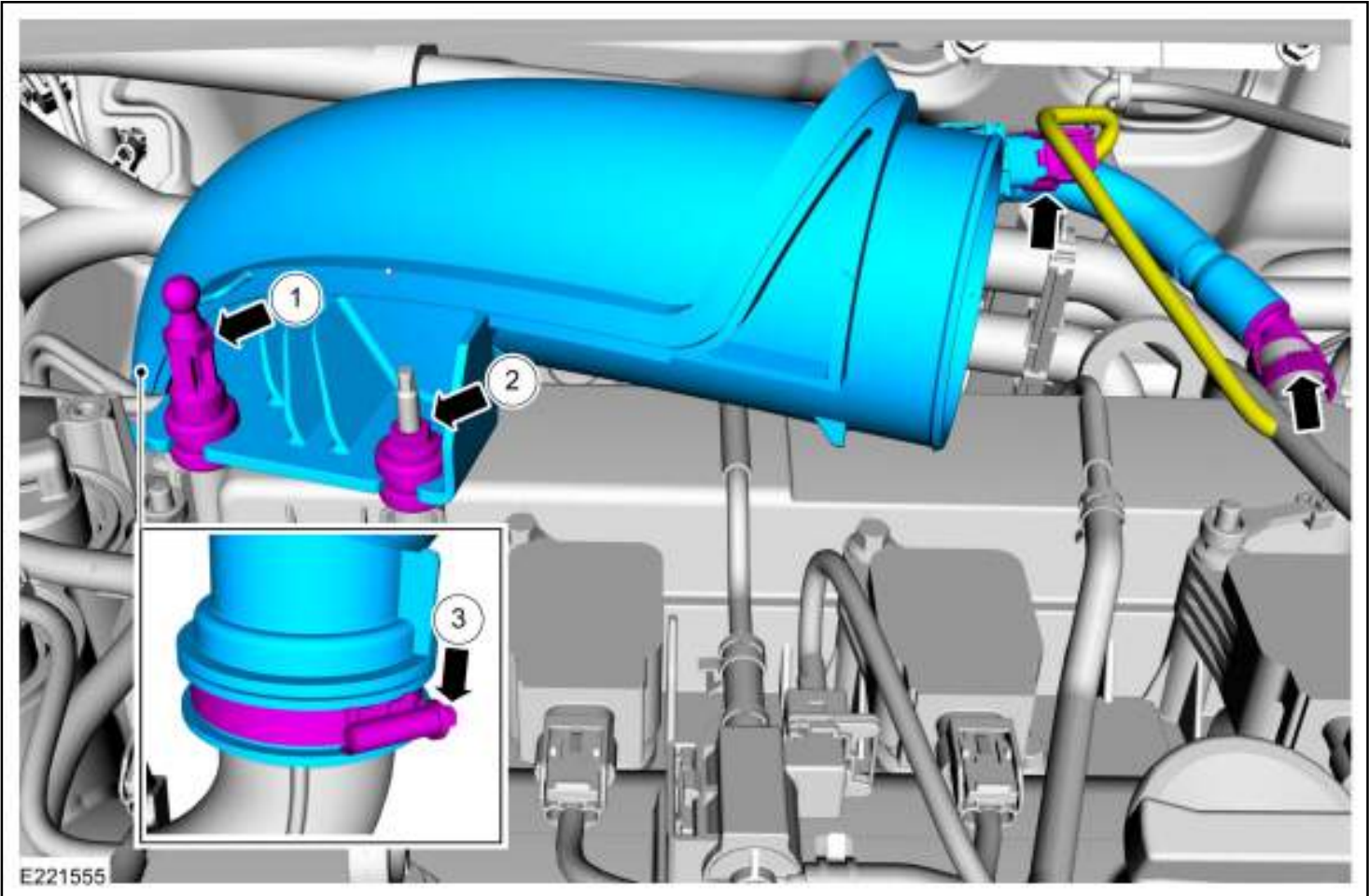

3.

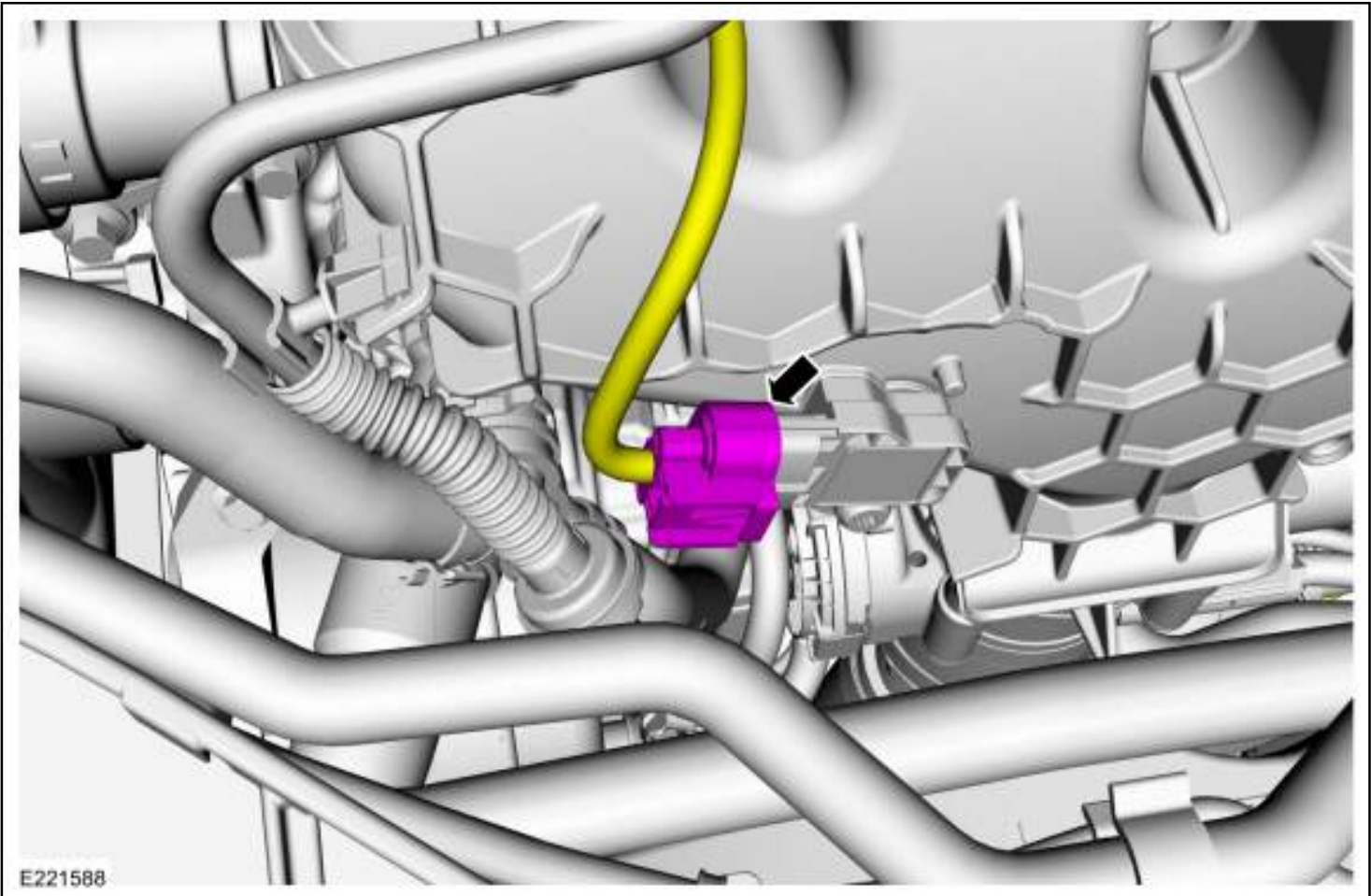

4.

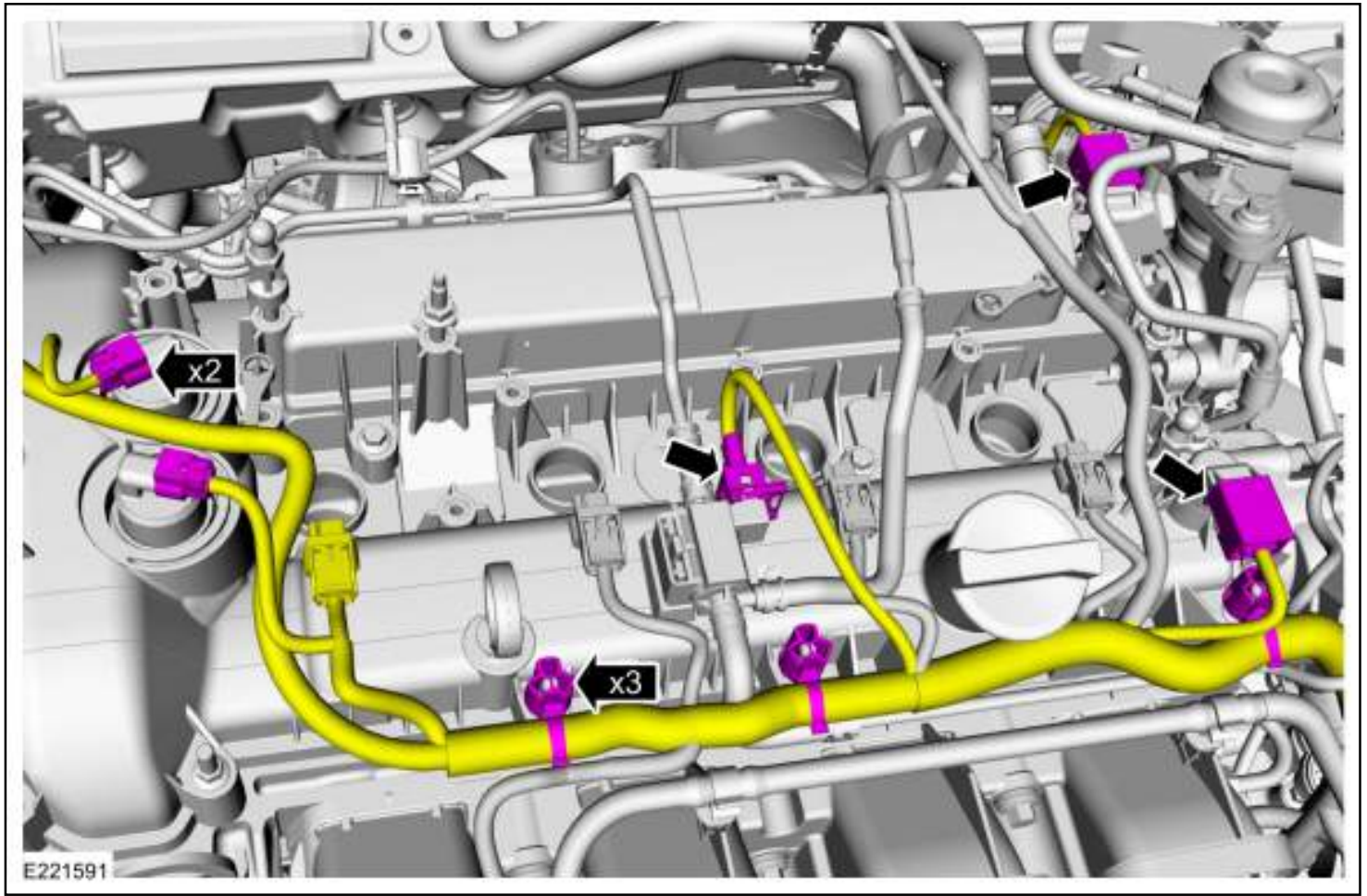

5. Use the General Equipment: Hose Clamp Remover/Installer

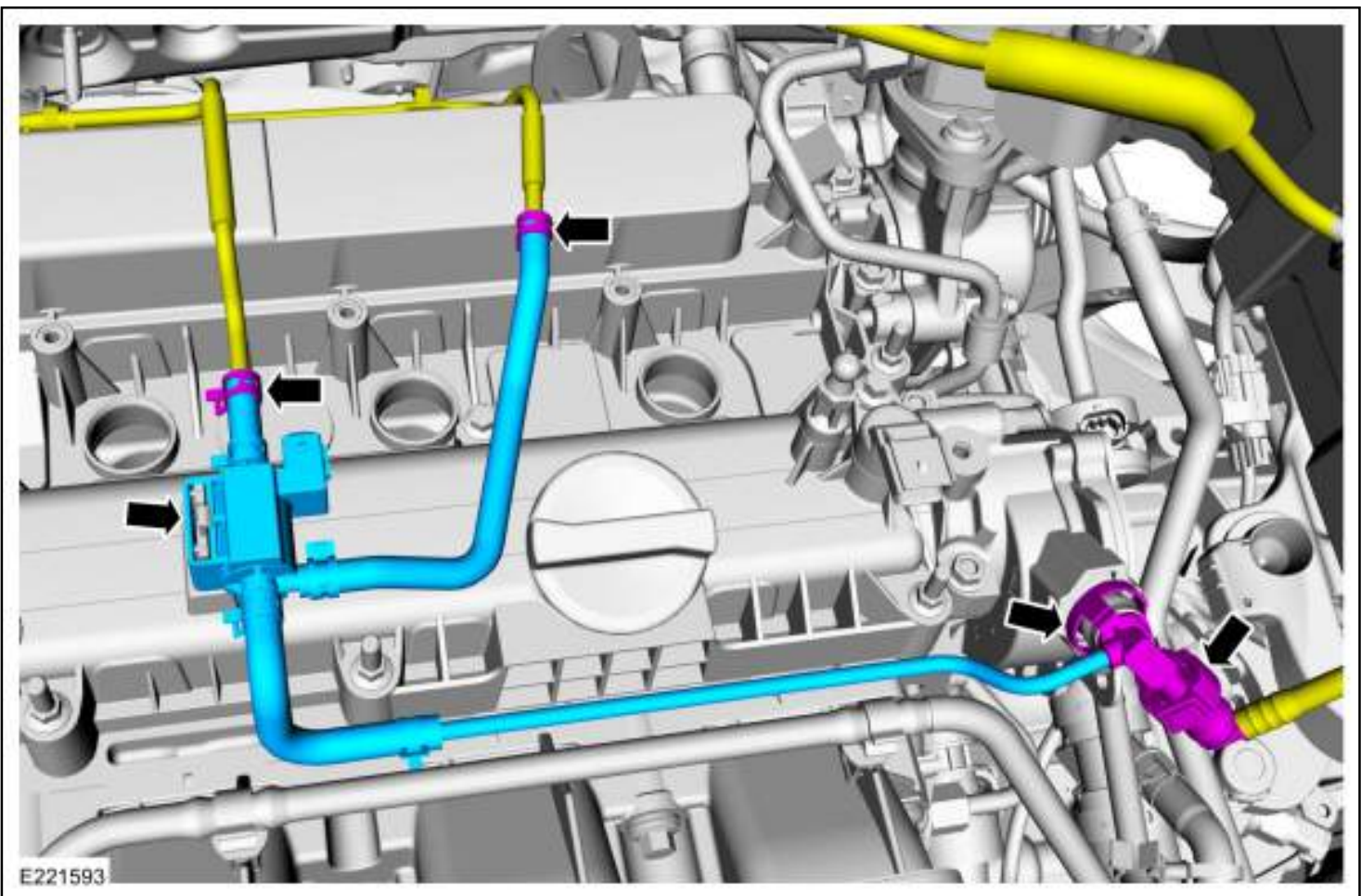

6.

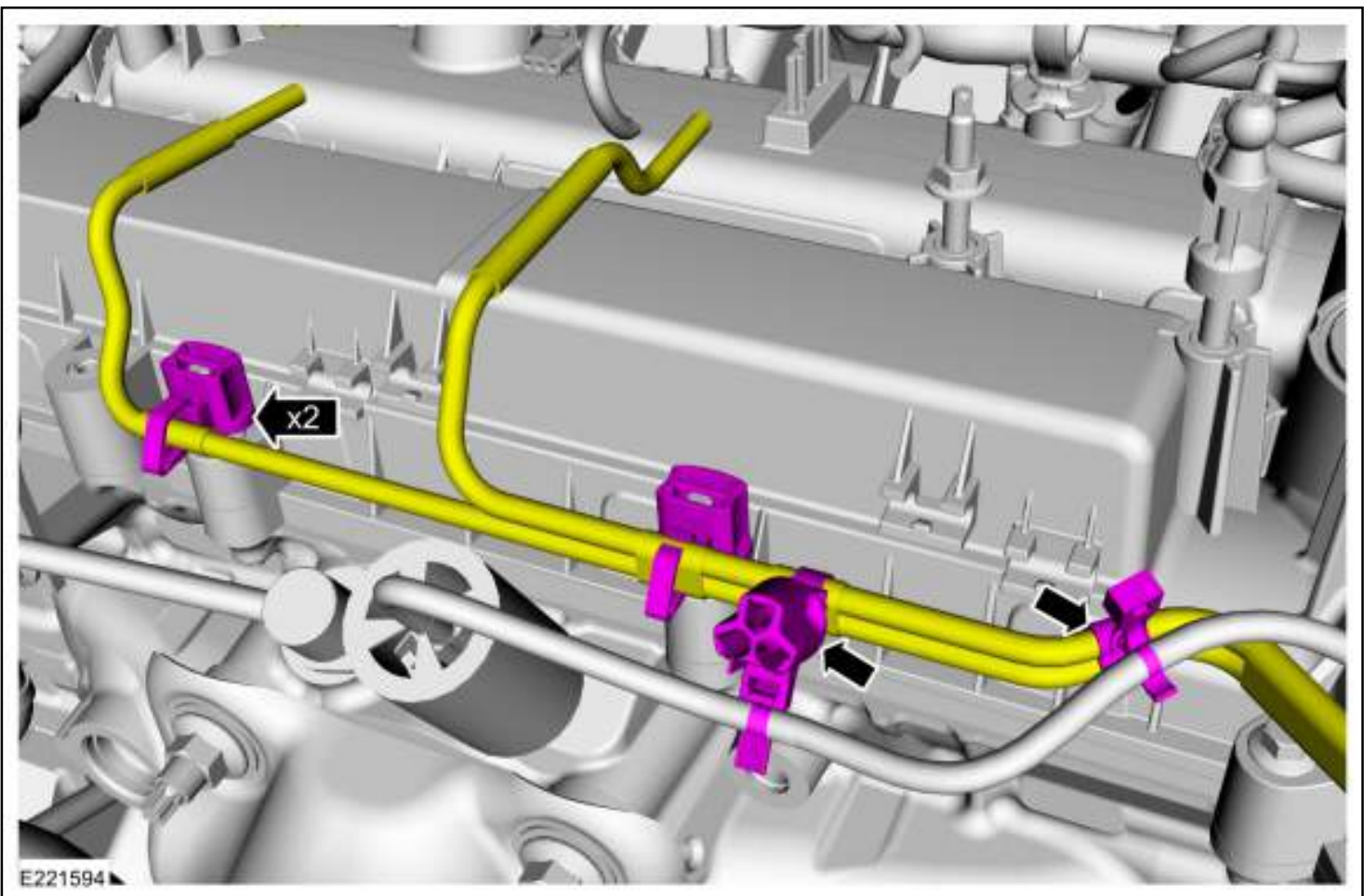

7.

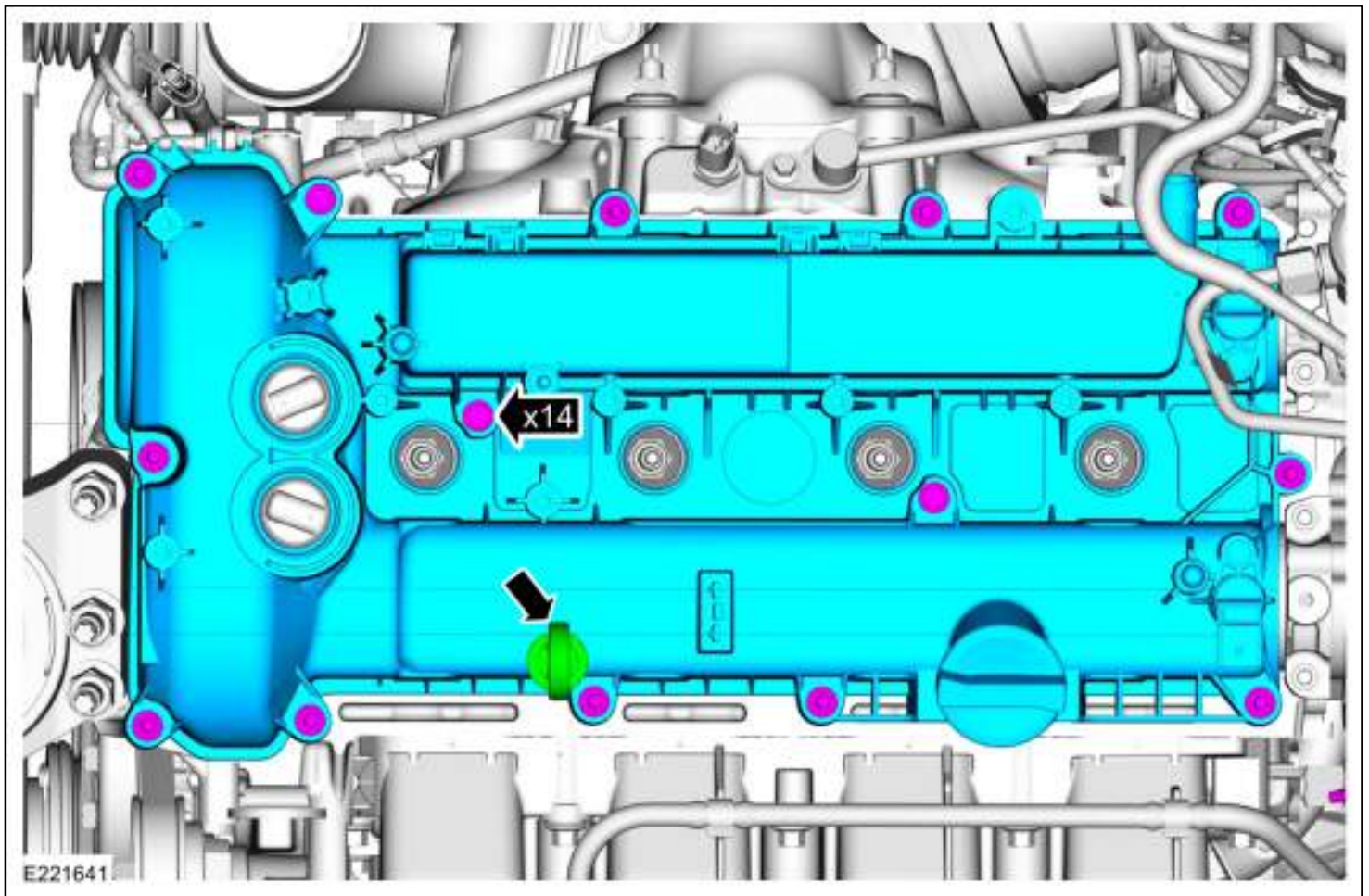

8. **NOTE:** *The gasket is to be reused unless damaged.*

Use Special Service Tool: 205-080 Installer, Differential Bearing.

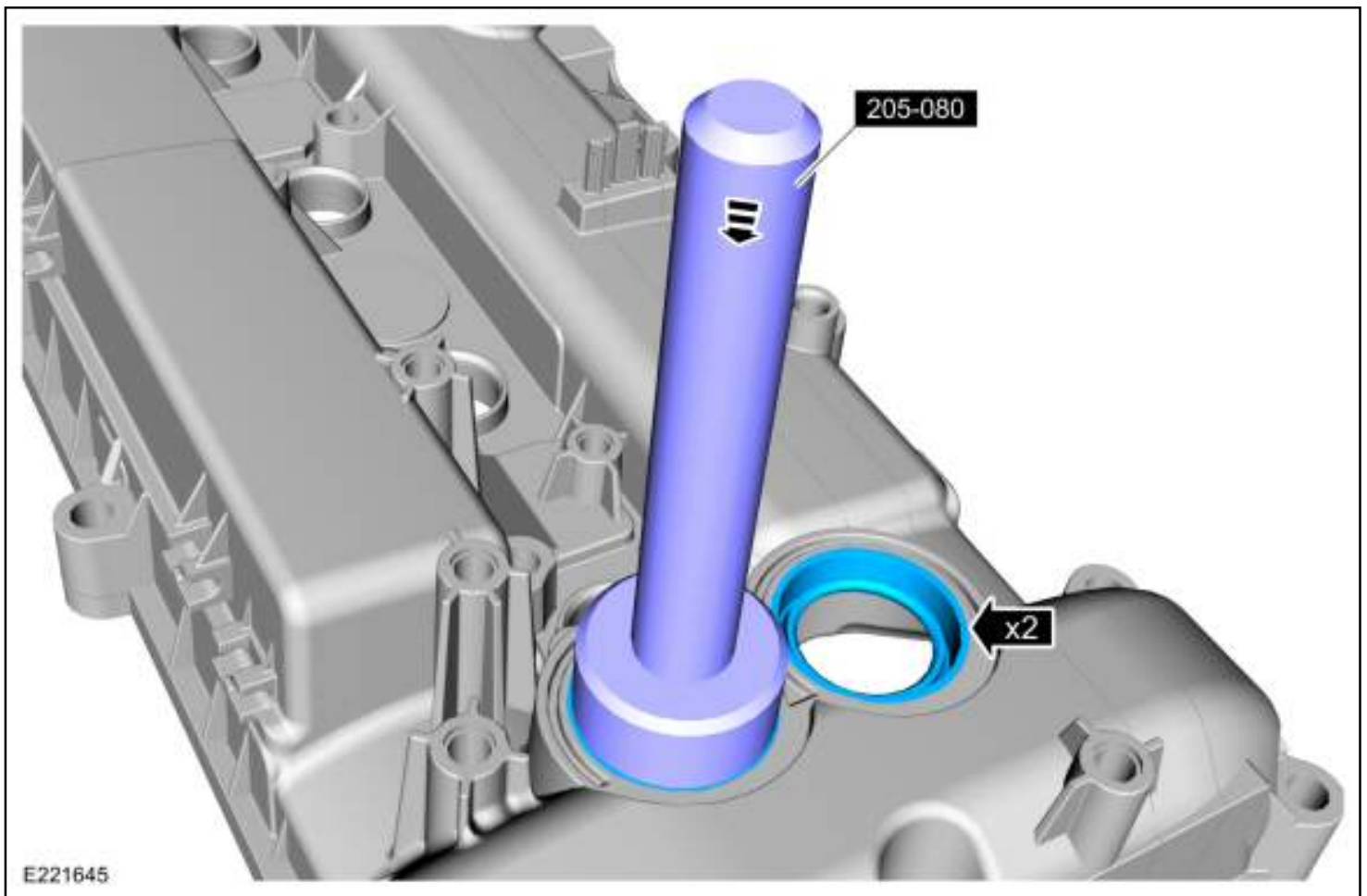

## Installation

1. To install, reverse the removal procedure.
2. **NOTE:** *This step is only necessary when installing a new component.*

Use Special Service Tool: 204-017 Installer, Wheel Hub Bearing Cup.

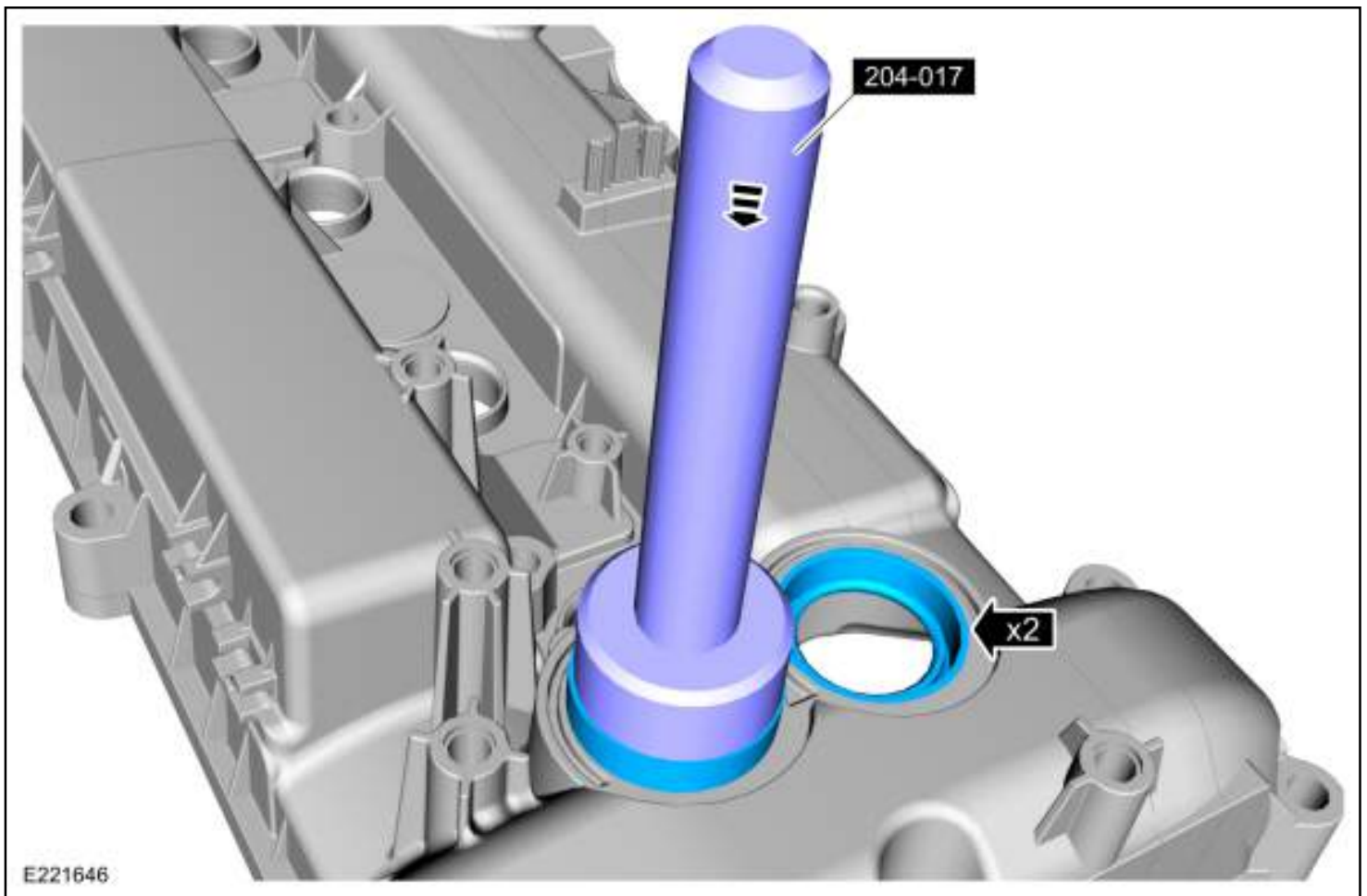

3. **NOTE:** *The component must be installed within 5 minutes of applying the sealant.*

*Material: Motorcraft® Silicone Gasket and Sealant / TA-30 (WSE-M4G323-A4)*

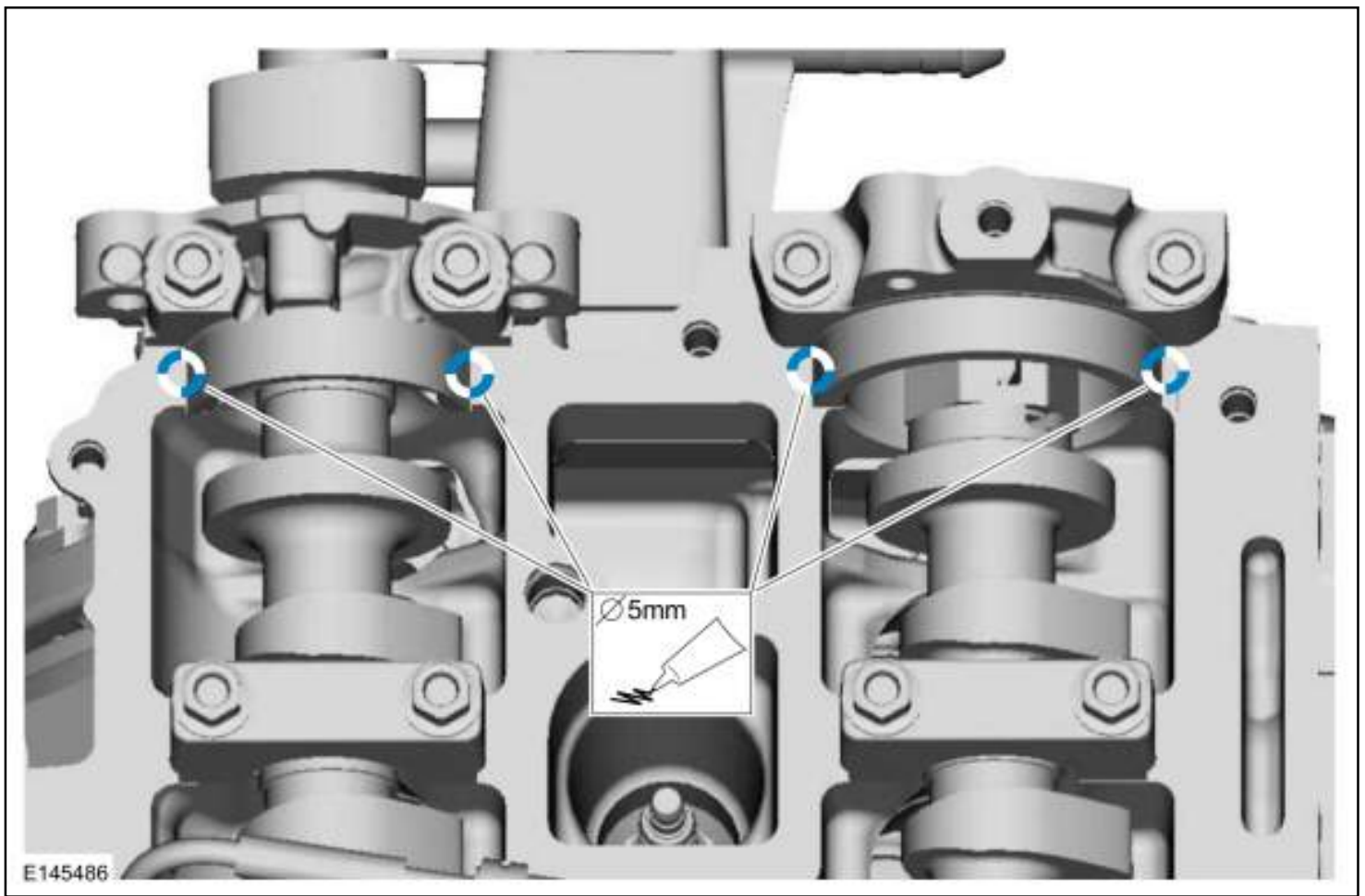

4. **NOTE:** *The component must be installed within 5 minutes of applying the sealant.*

*Material: Motorcraft® Silicone Gasket and Sealant / TA-30 (WSE-M4G323-A4)*

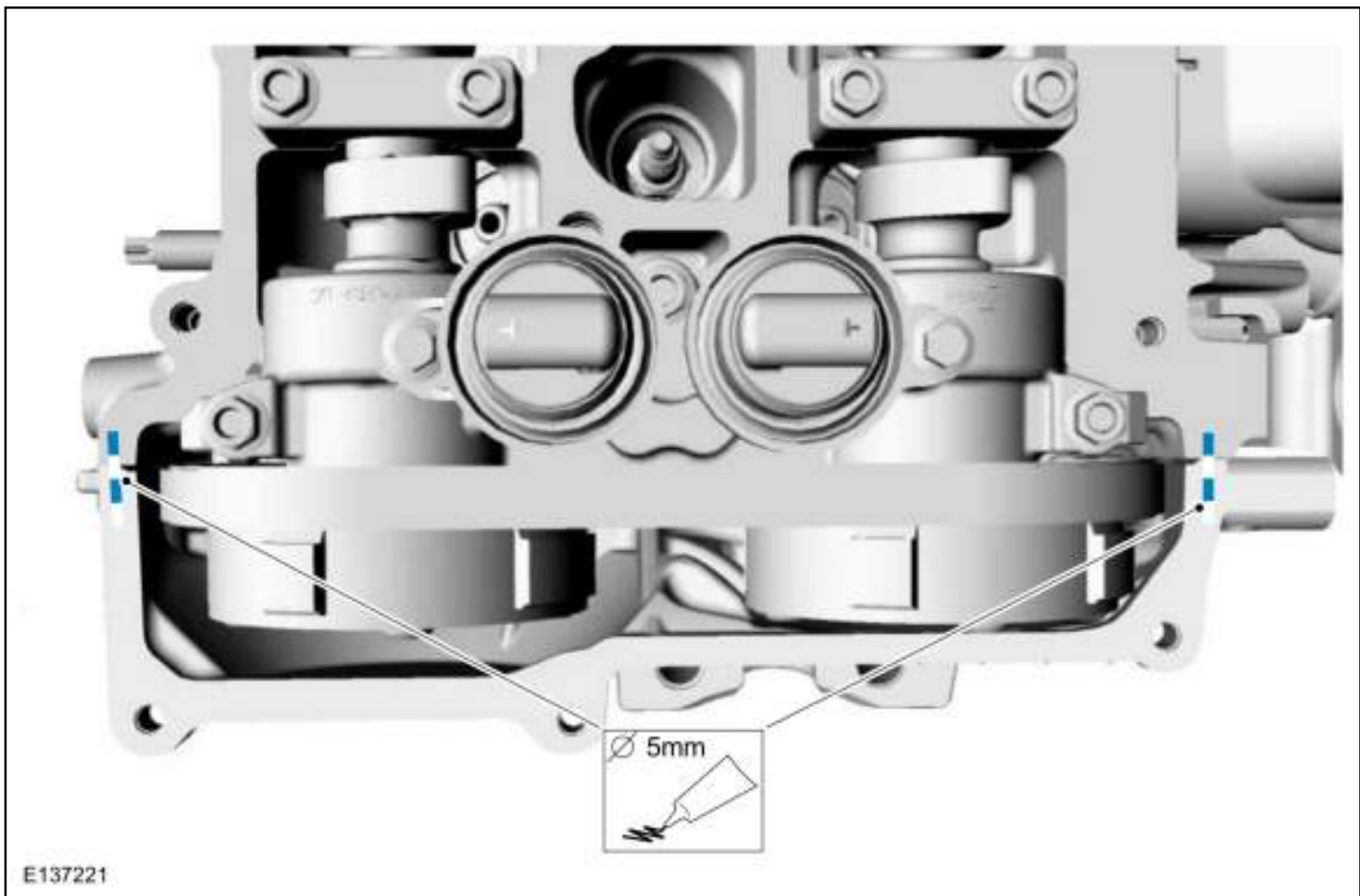

5. **NOTE:** *The gasket is to be reused unless damaged.*

*Torque: 89 lb.in (10 Nm)*



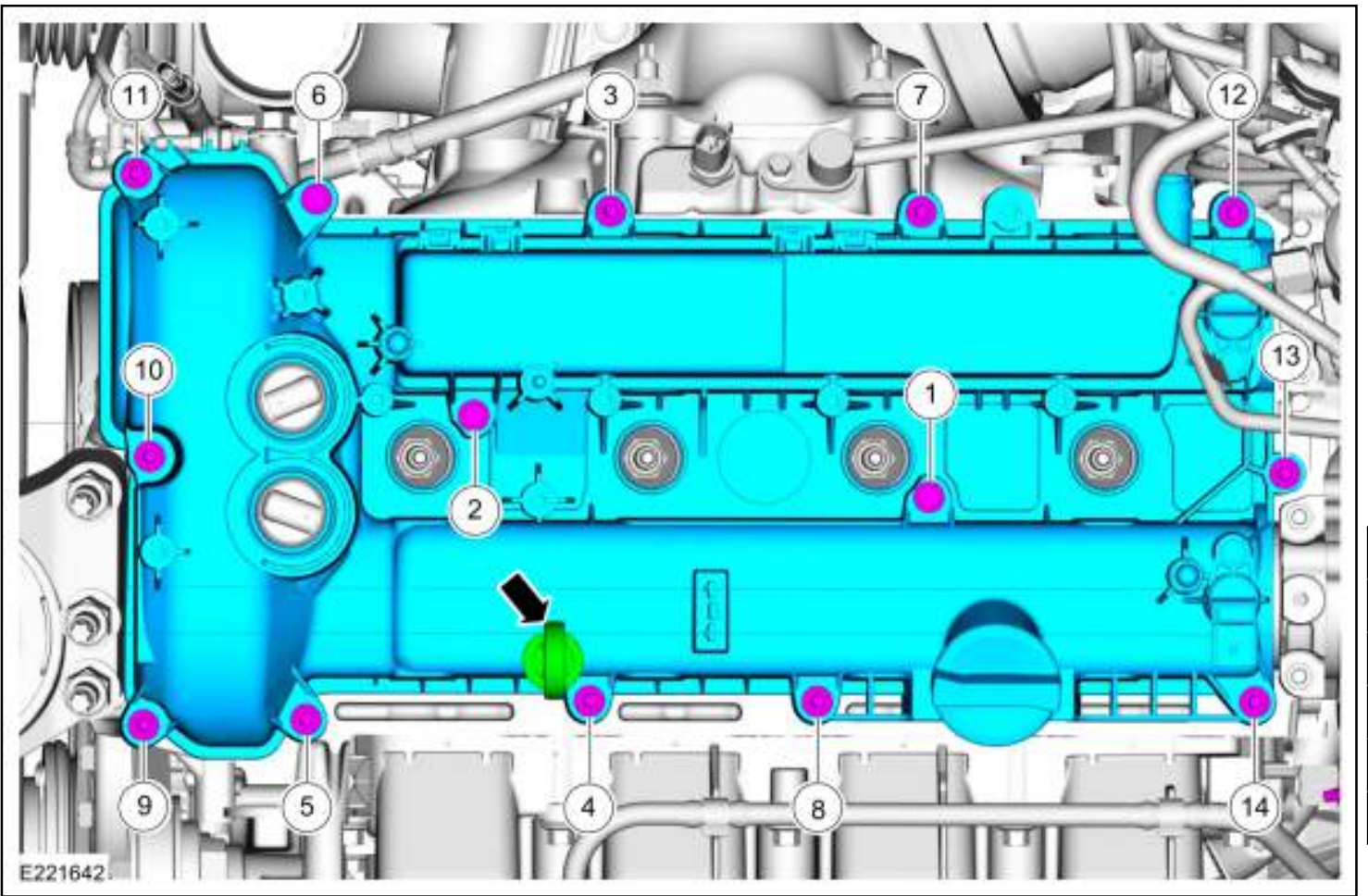

Copyright © 2019 Ford Motor Company



# Engine Mount

Base Part Number: Base Part Number: 6F012

## Special Tool(s) / General Equipment

Trolley Jack
--------------

Wooden Block
--------------

## Removal

1.

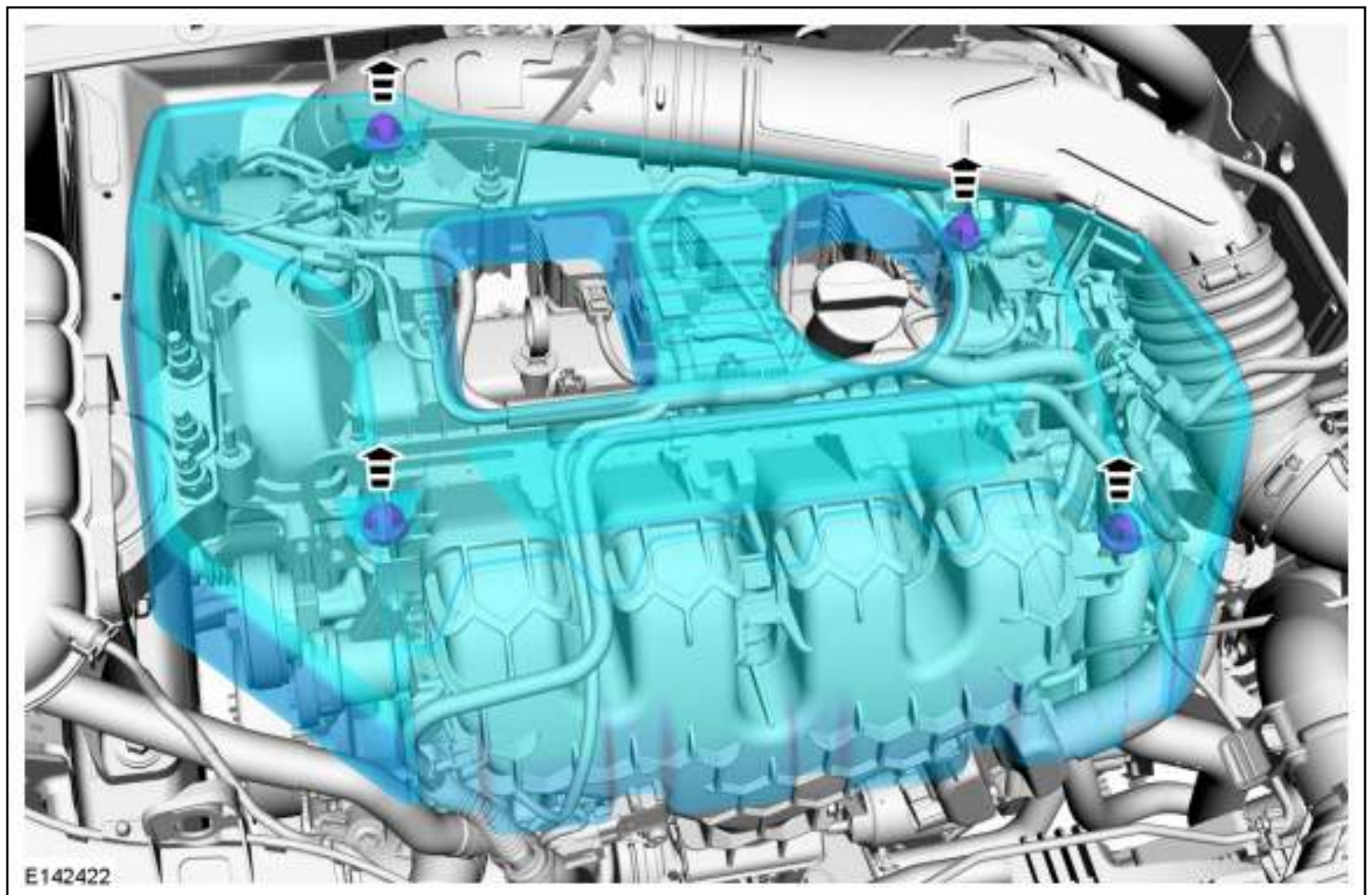

2. Refer to: Jacking and Lifting (100-02 Jacking and Lifting) .

3.

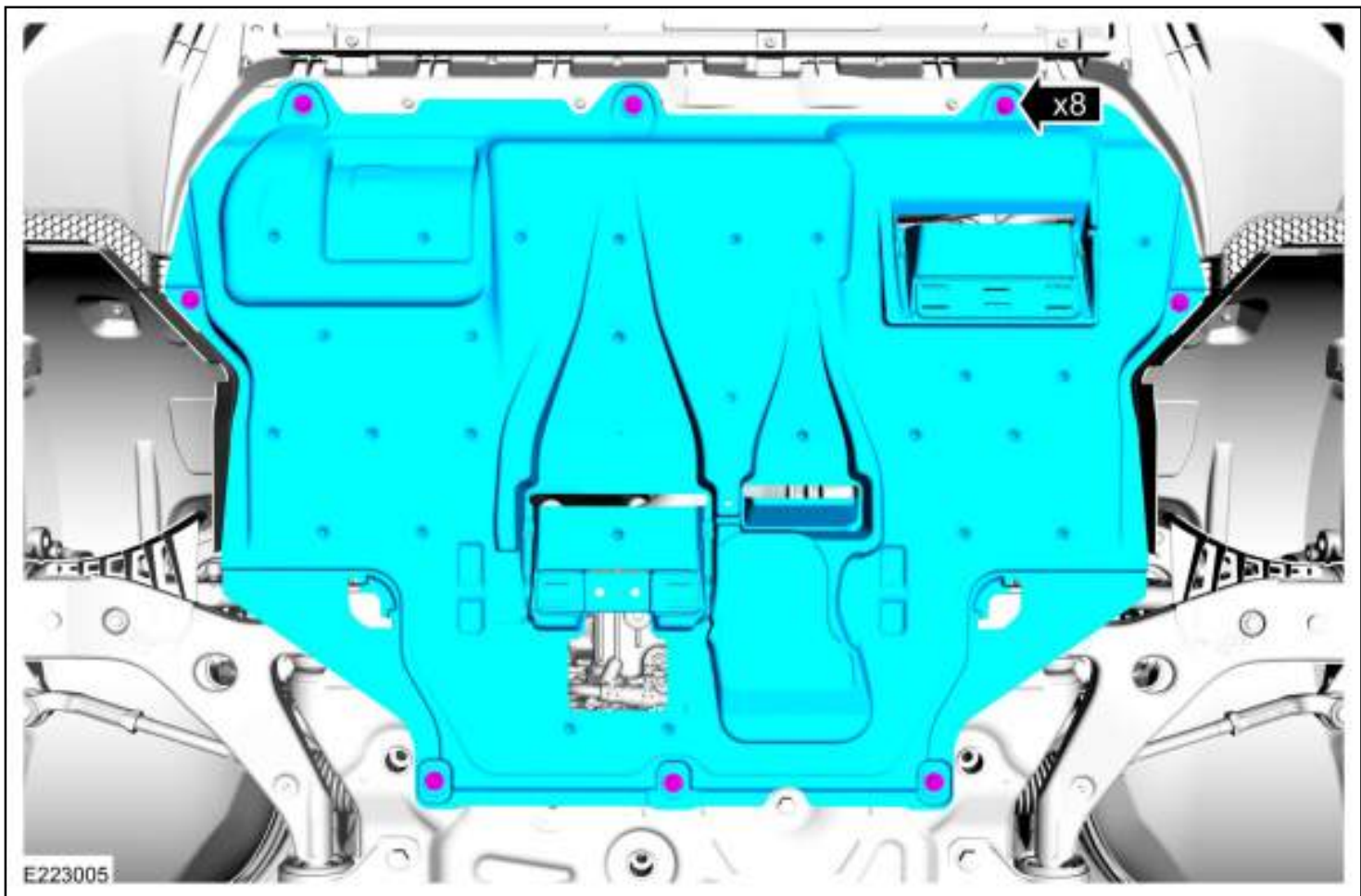

4. Use the General Equipment: Wooden Block  
Use the General Equipment: Trolley Jack

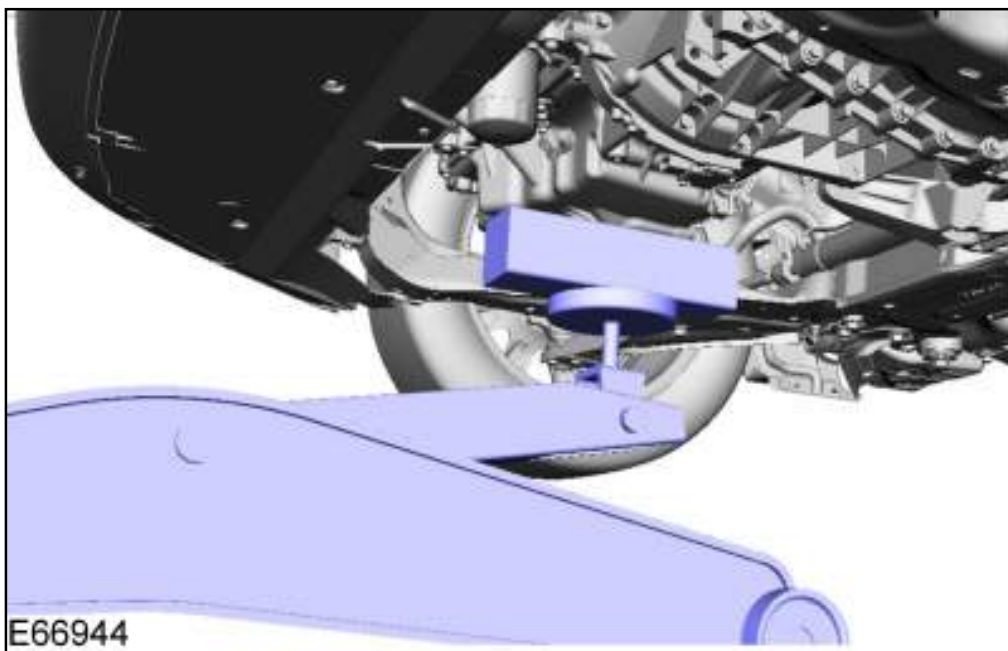

- 5.

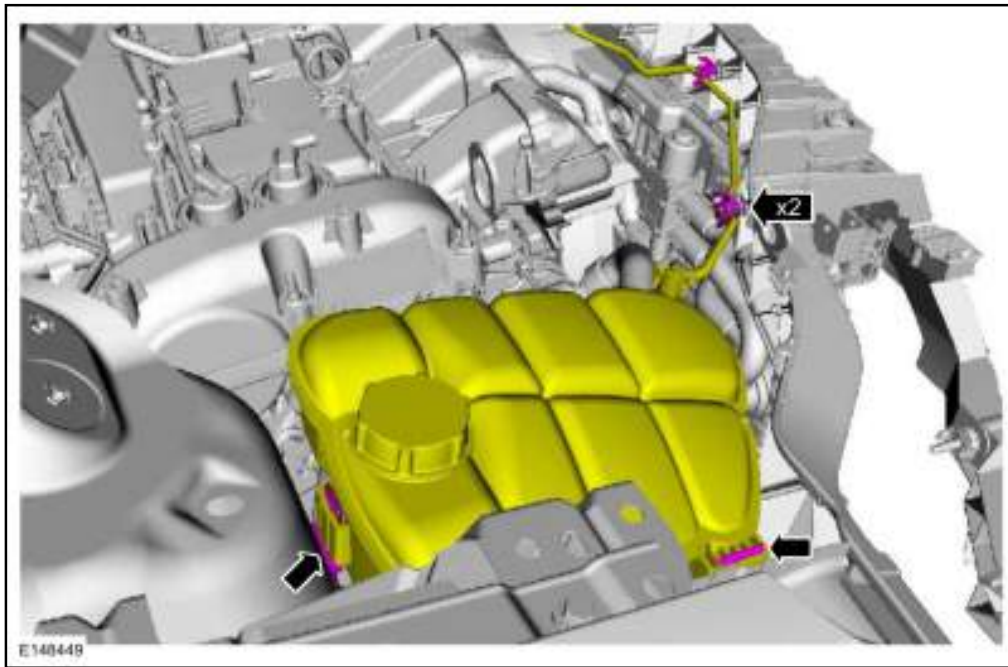

6.

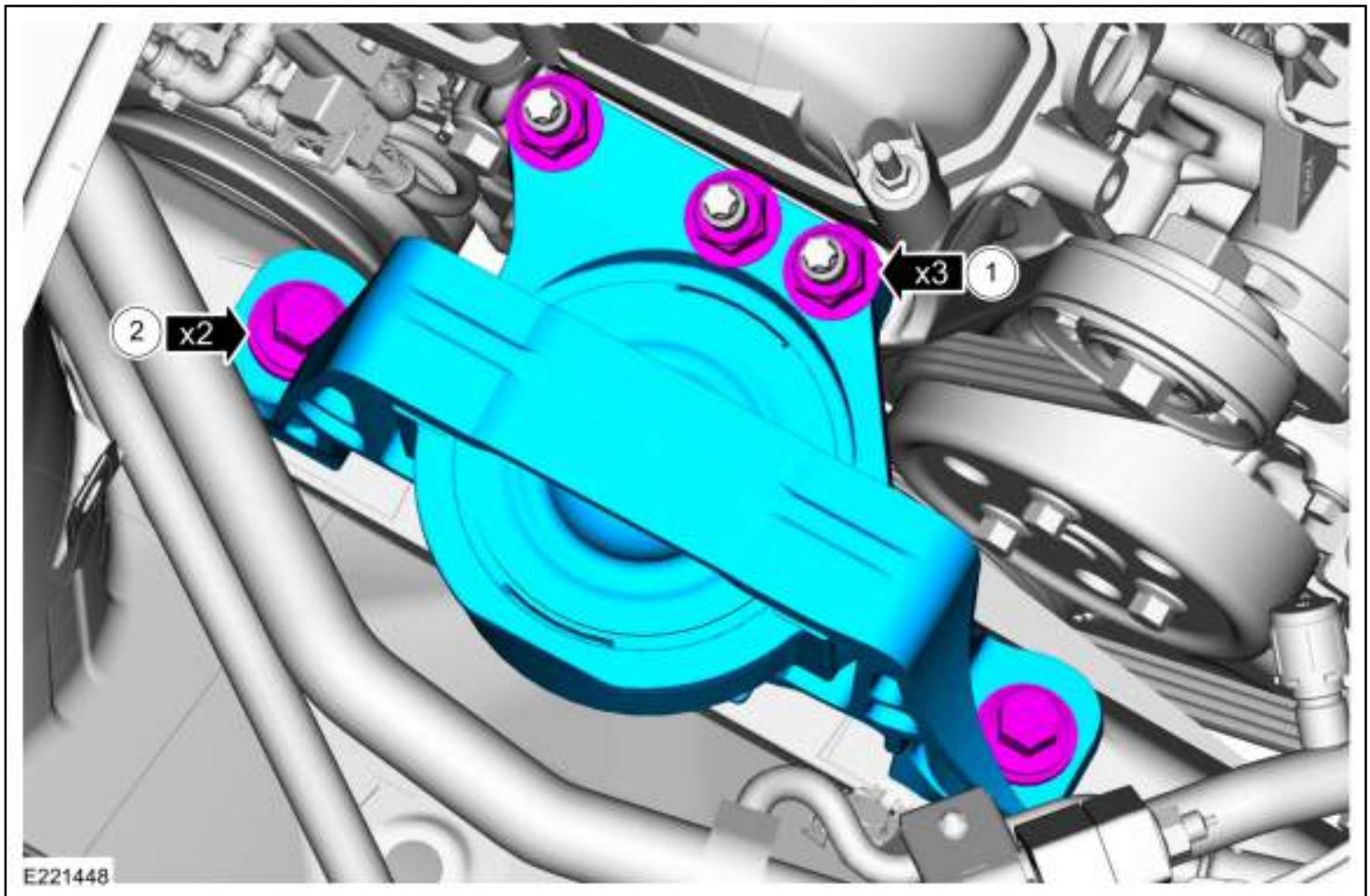

cardiagn.com

### Installation

1. *Torque:* 106 lb.in (12 Nm)

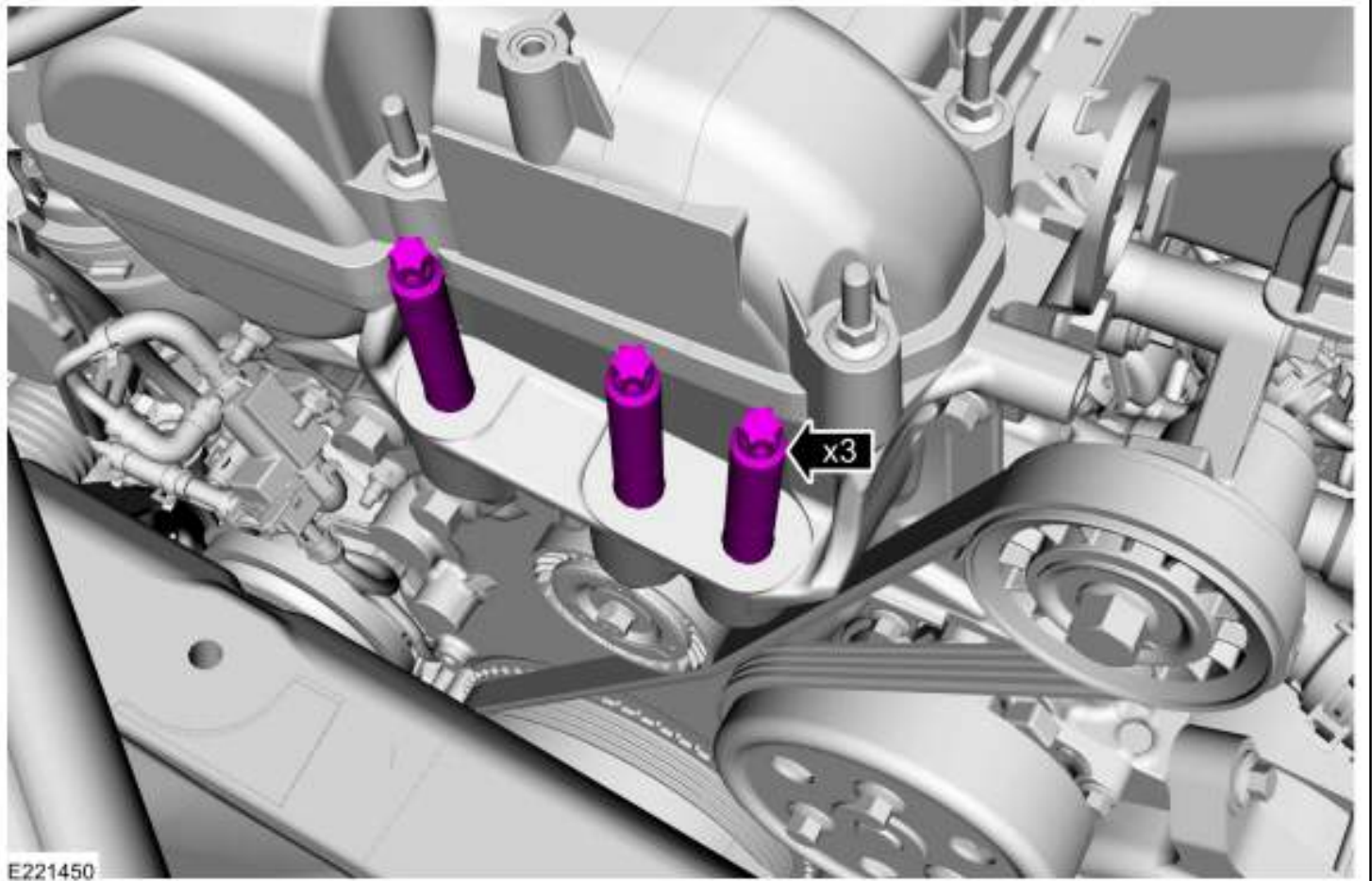

1. *Torque: 59 lb.ft (80 Nm)*
2. **NOTE:** *Only tighten the bolts finger tight at this stage.*

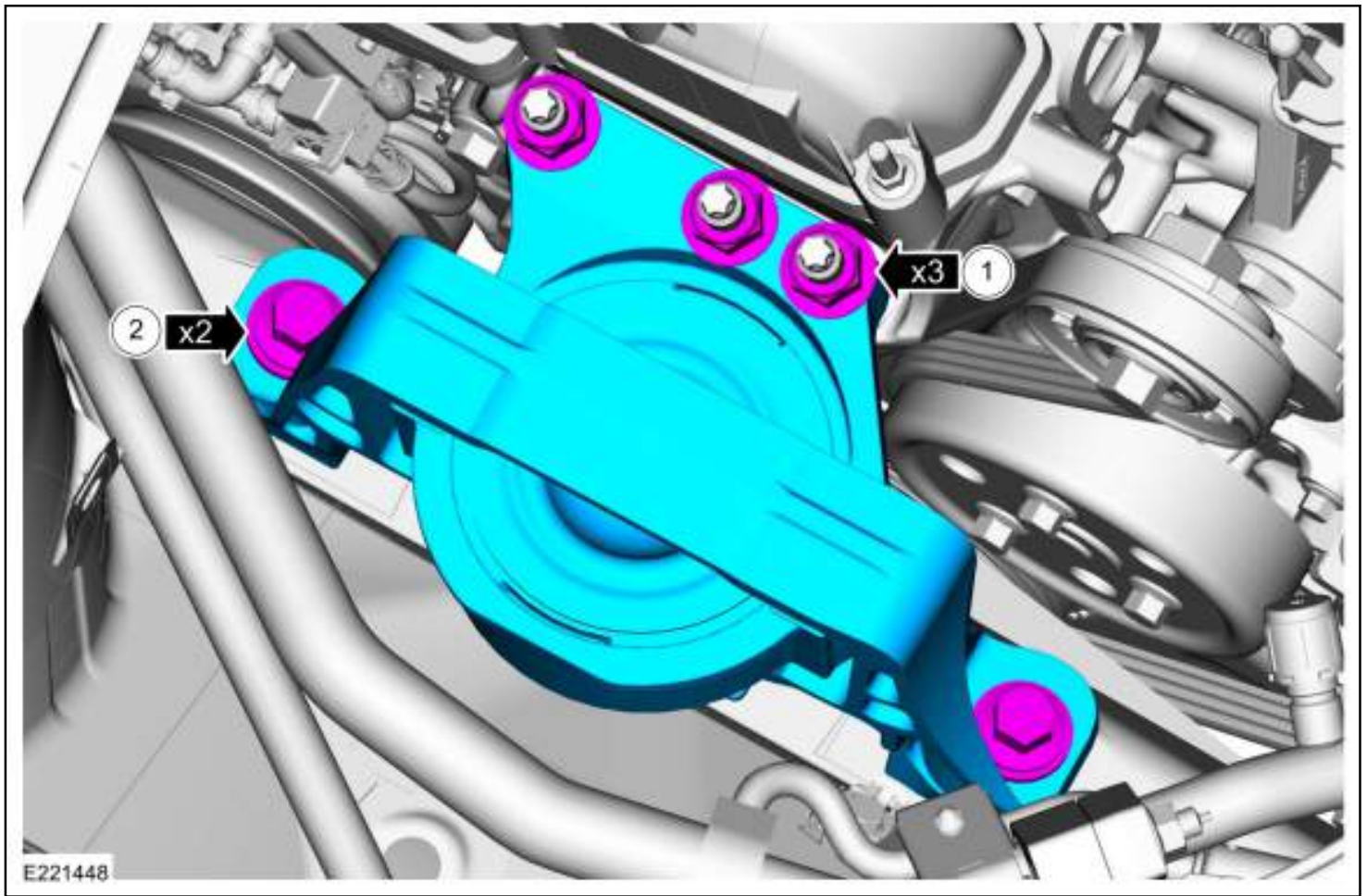

3. Remove the following items:

1. Use the General Equipment: Wooden Block  
Use the General Equipment: Trolley Jack

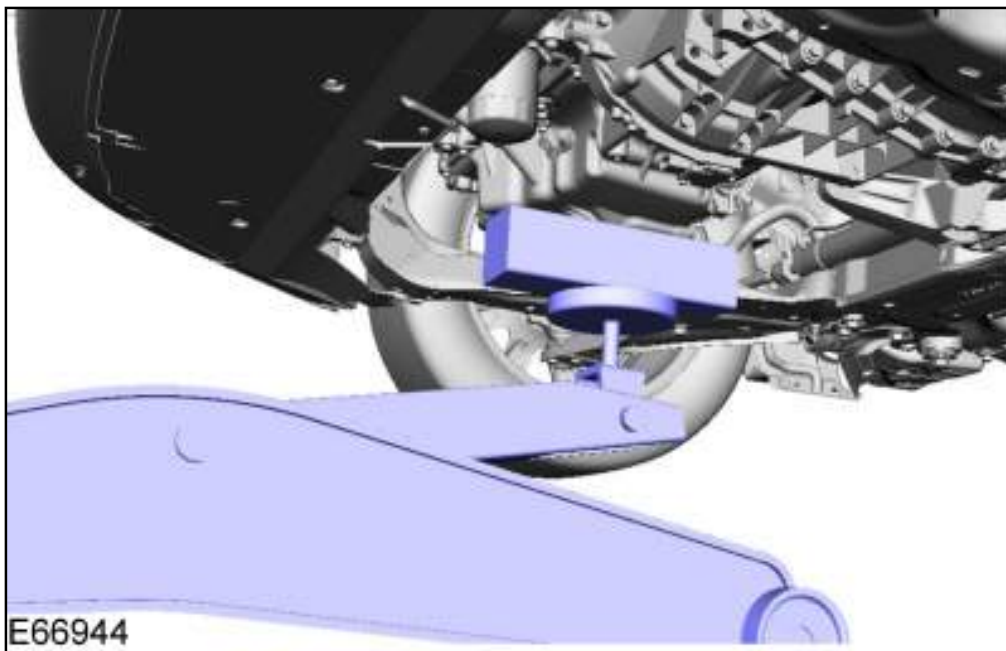

4. *Torque:* 66 lb.ft (90 Nm)

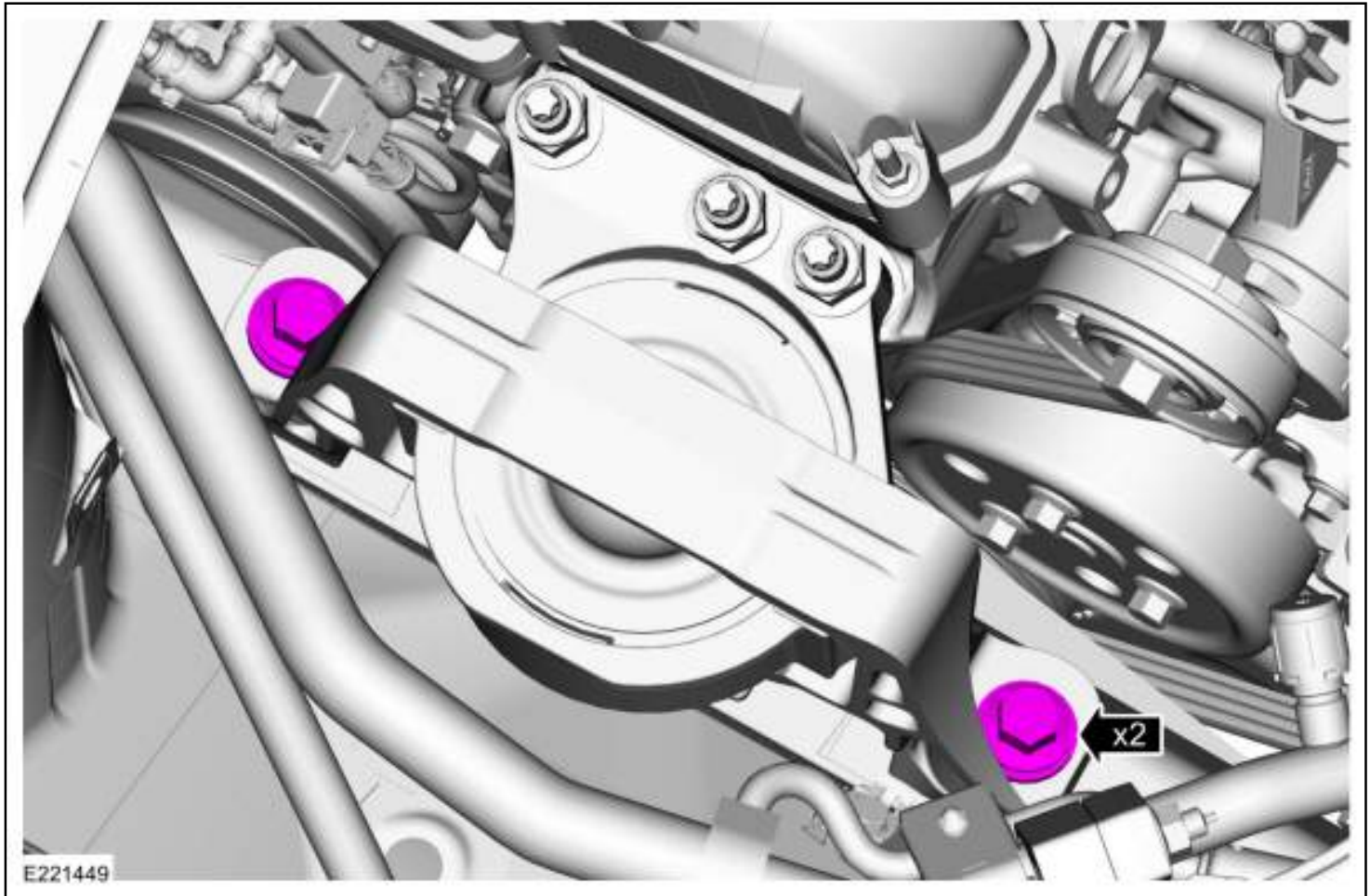

5.

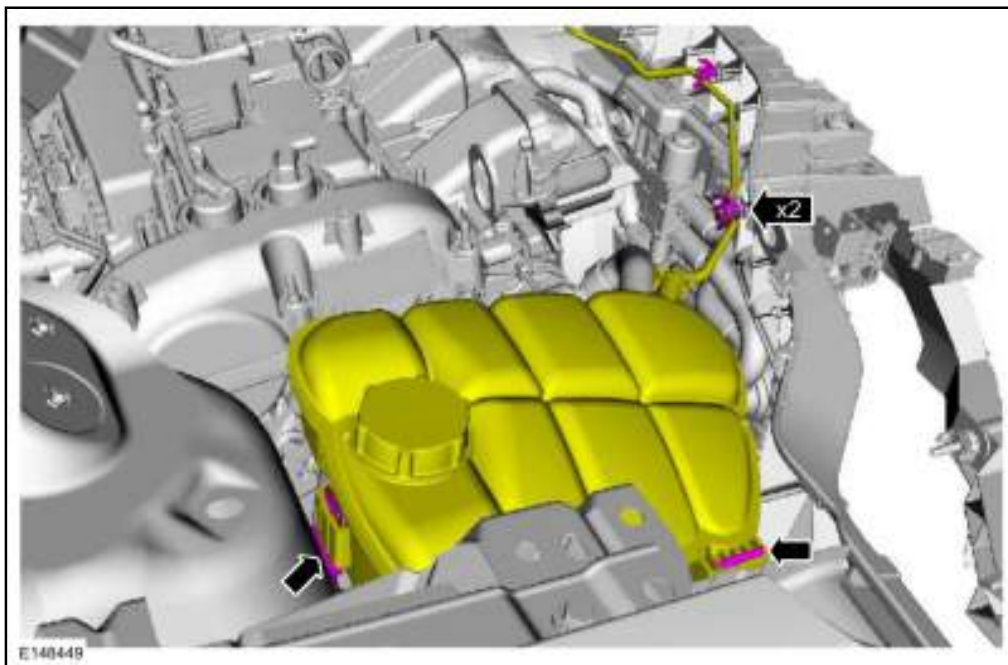

6. Refer to: Jacking and Lifting (100-02 Jacking and Lifting) .

7.

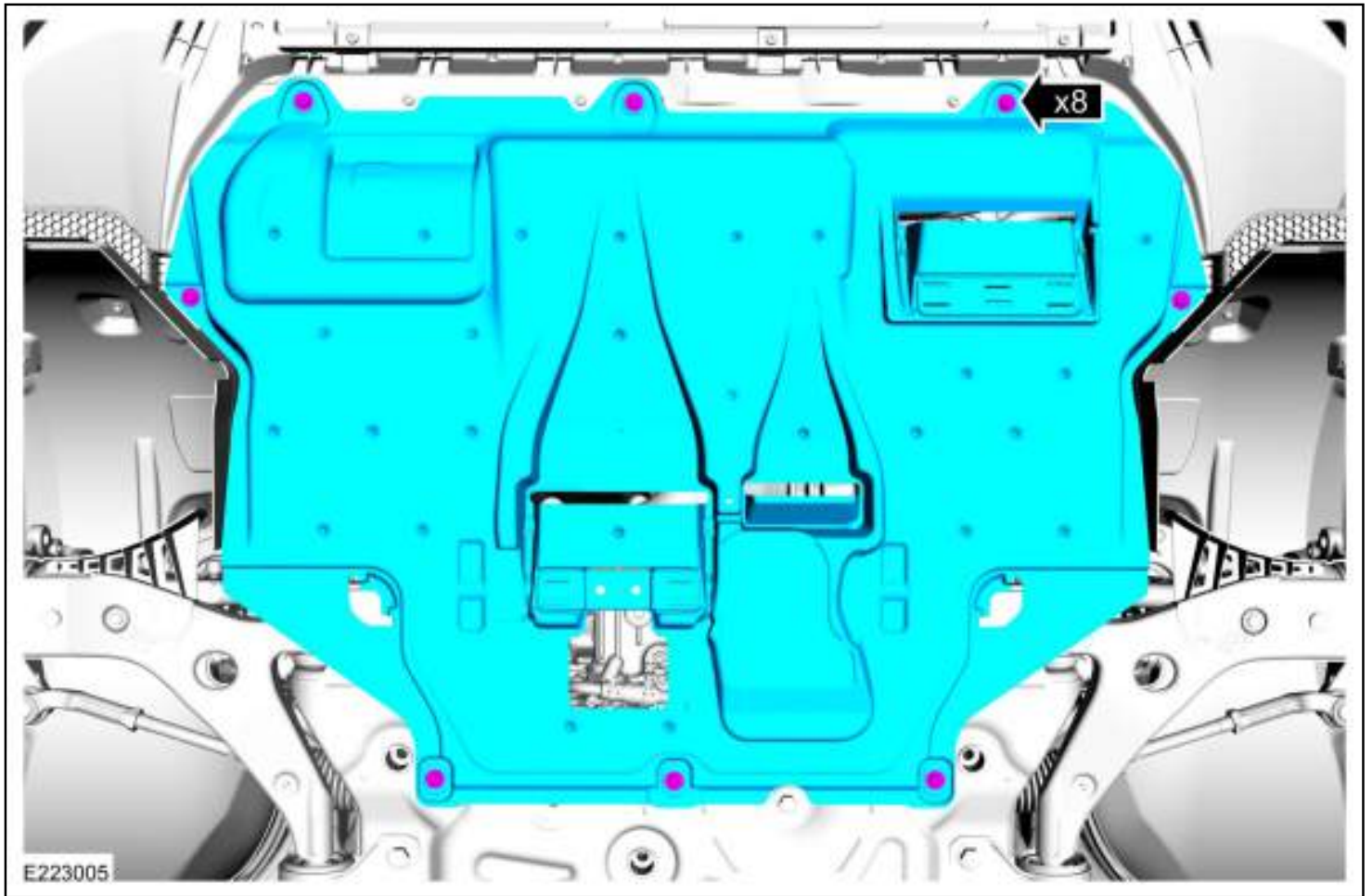

8.

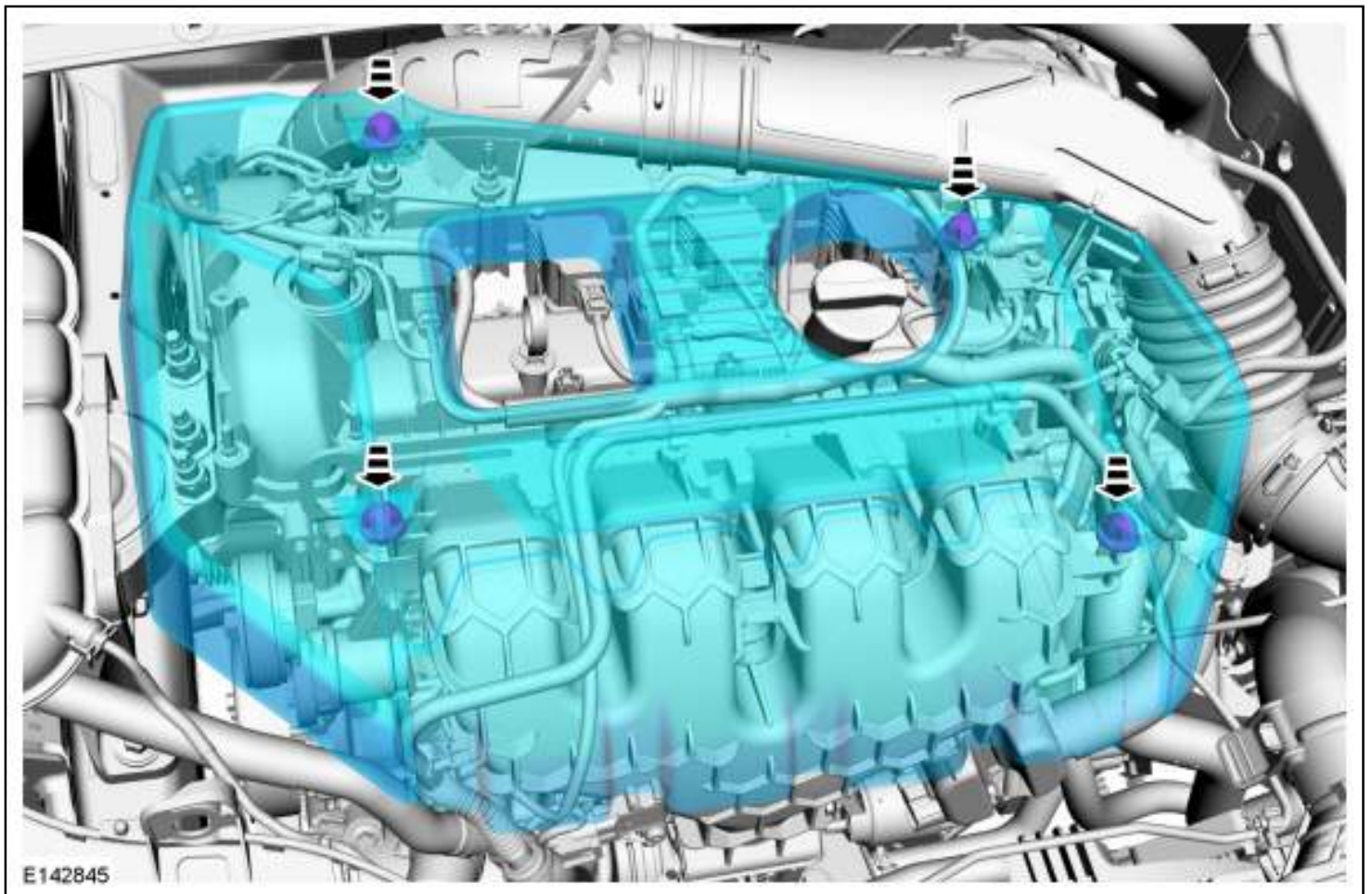



# Oil Pan

Base Part Number: Base Part Number: 6675

## Special Tool(s) / General Equipment

Strap Wrench
Plastic Scraper
Oil Drain Equipment
Fluid Container

## Materials

Name	Specification
Motorcraft® Metal Surface Prep Wipes ZC-31-B	-
Motorcraft® Silicone Gasket and Sealant TA-30	WSE-M4G323-A4

## Removal

- 1.

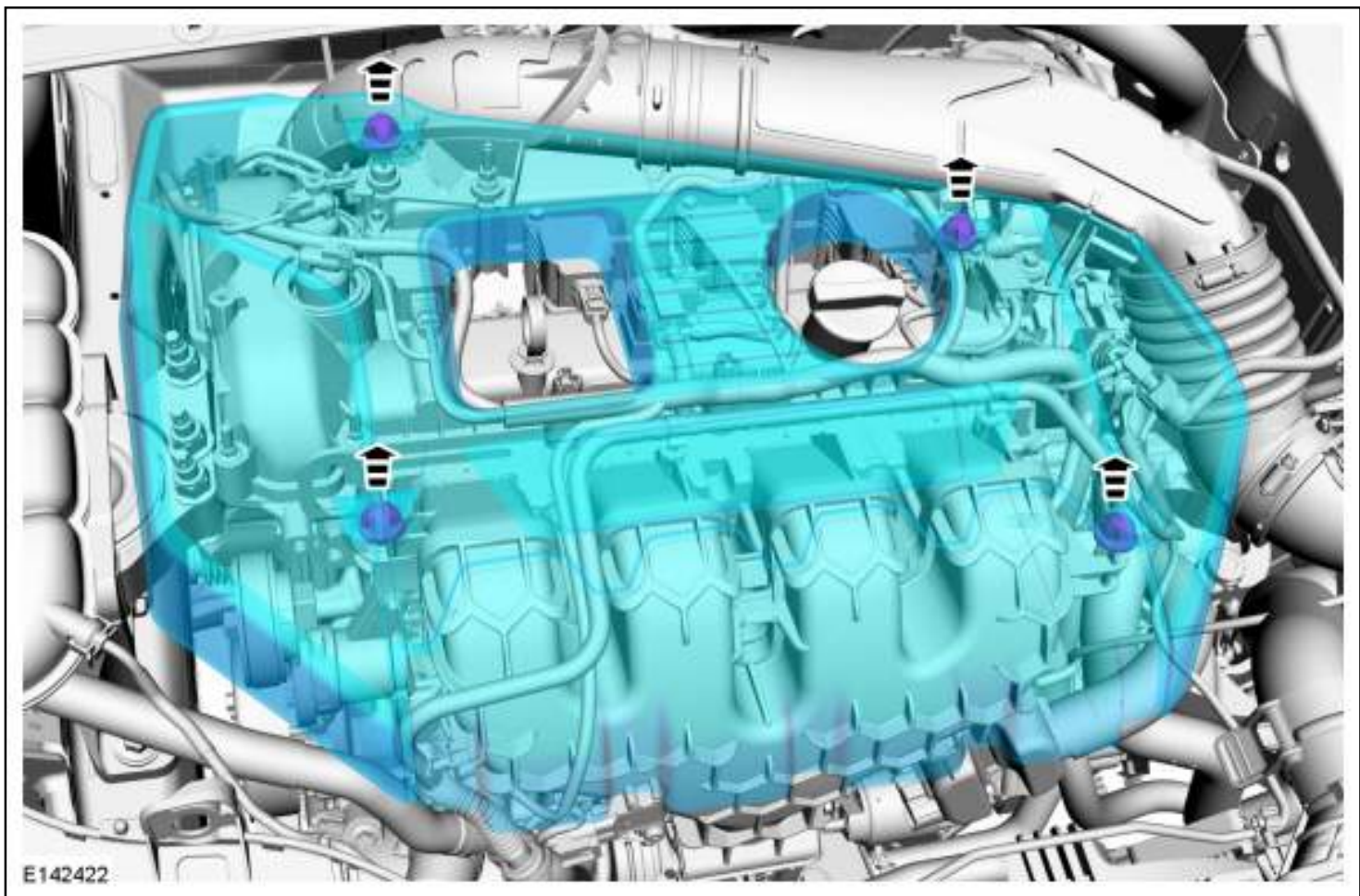

2. Remove the following items:

1. Refer to: Air Conditioning (A/C) Compressor Belt (303-05 Accessory Drive - 2.3L EcoBoost (257kW/350PS) - MI4) .
2. Refer to: Transfer Case (308-07 Transfer Case) .

3. Loosen: 3 turn(s)

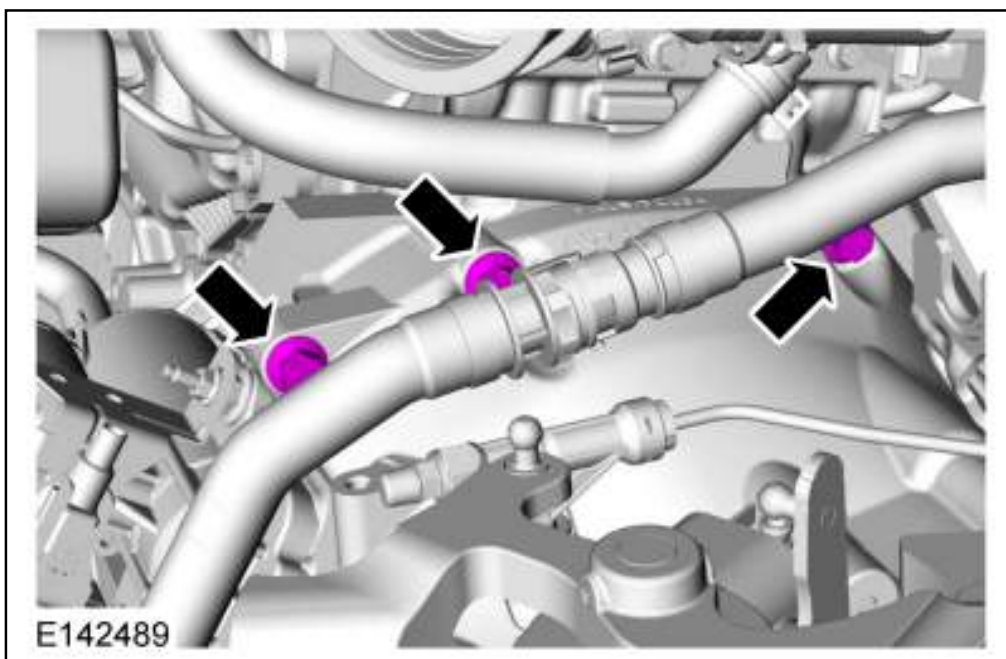

4.

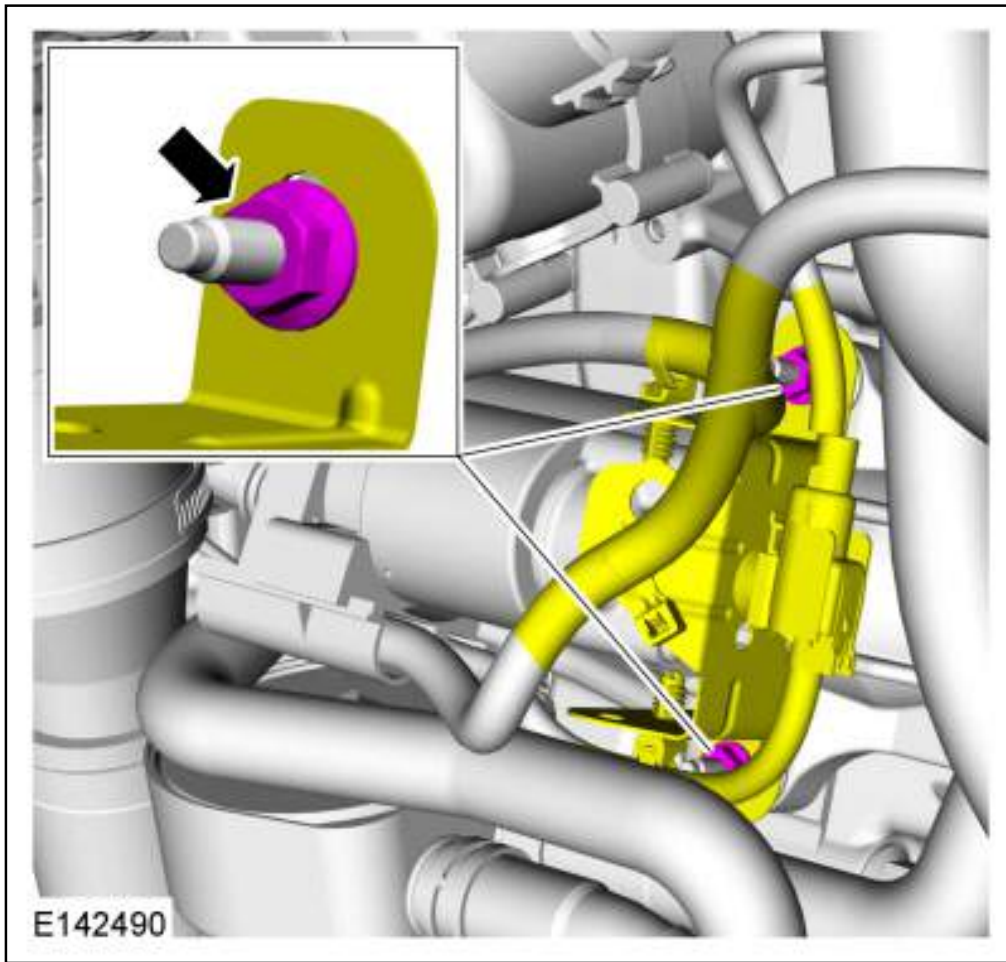

5.

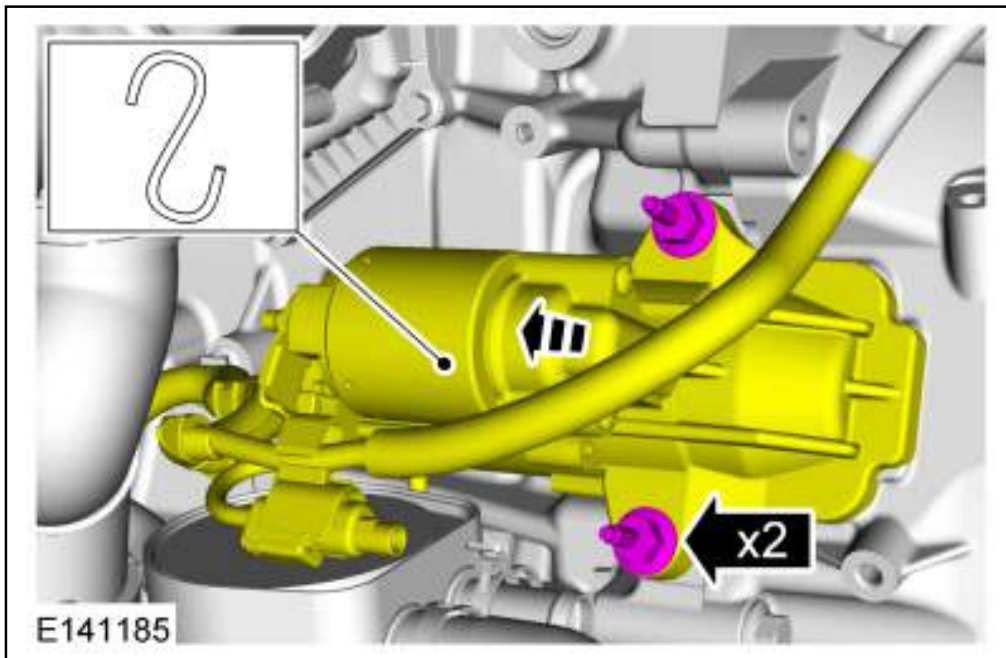

6. **NOTE:** *Be prepared to collect escaping fluid.*

Use the General Equipment: Oil Drain Equipment  
Torque: 19 lb.ft (26 Nm)

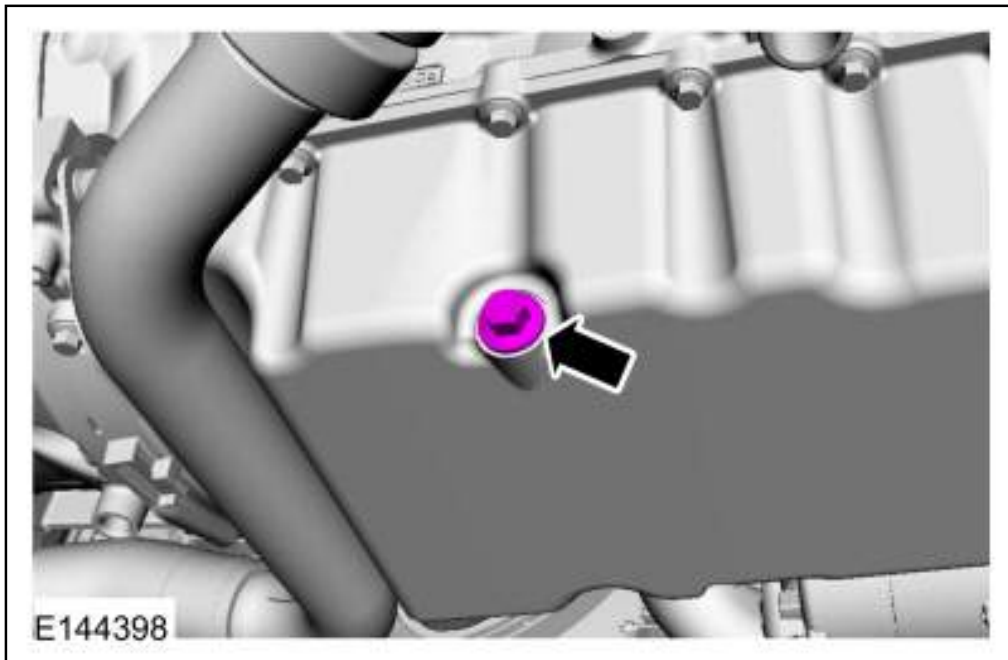

7. Use the General Equipment: Fluid Container  
Use the General Equipment: Strap Wrench

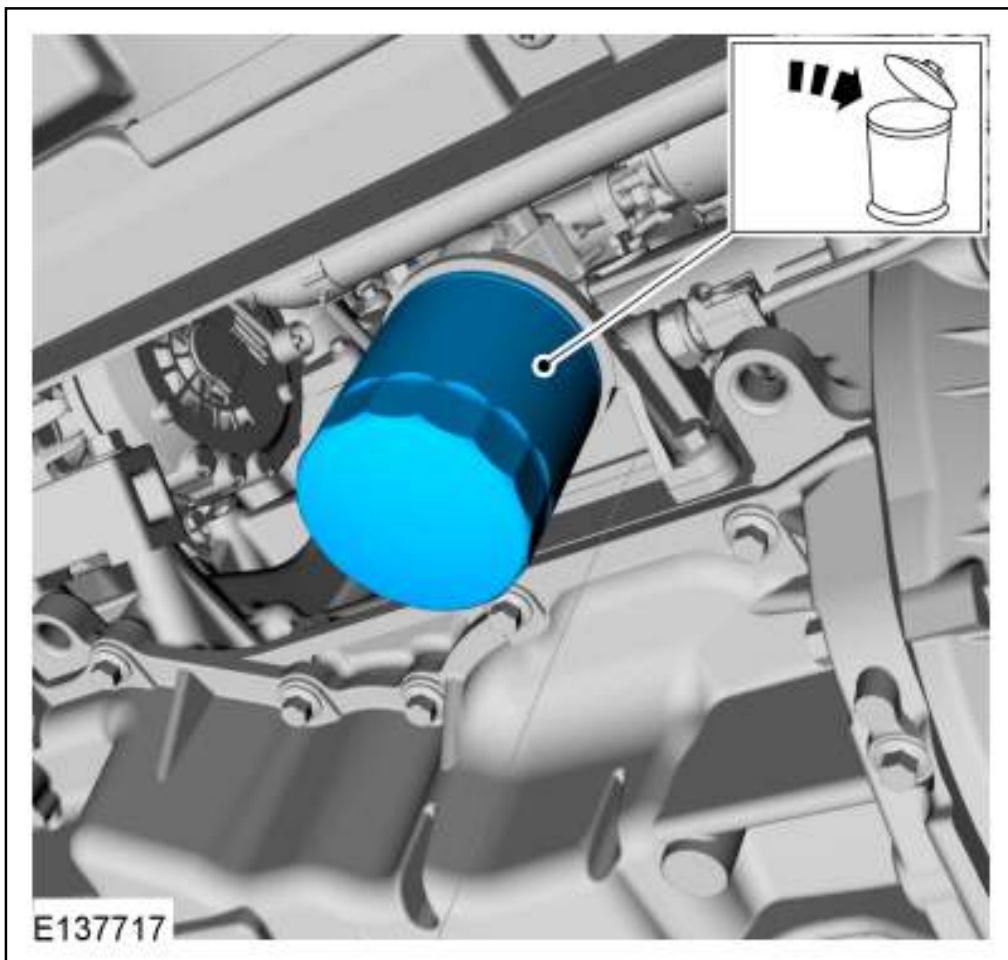

8. **NOTICE:** Make sure that no strain is placed on the refrigerant lines.

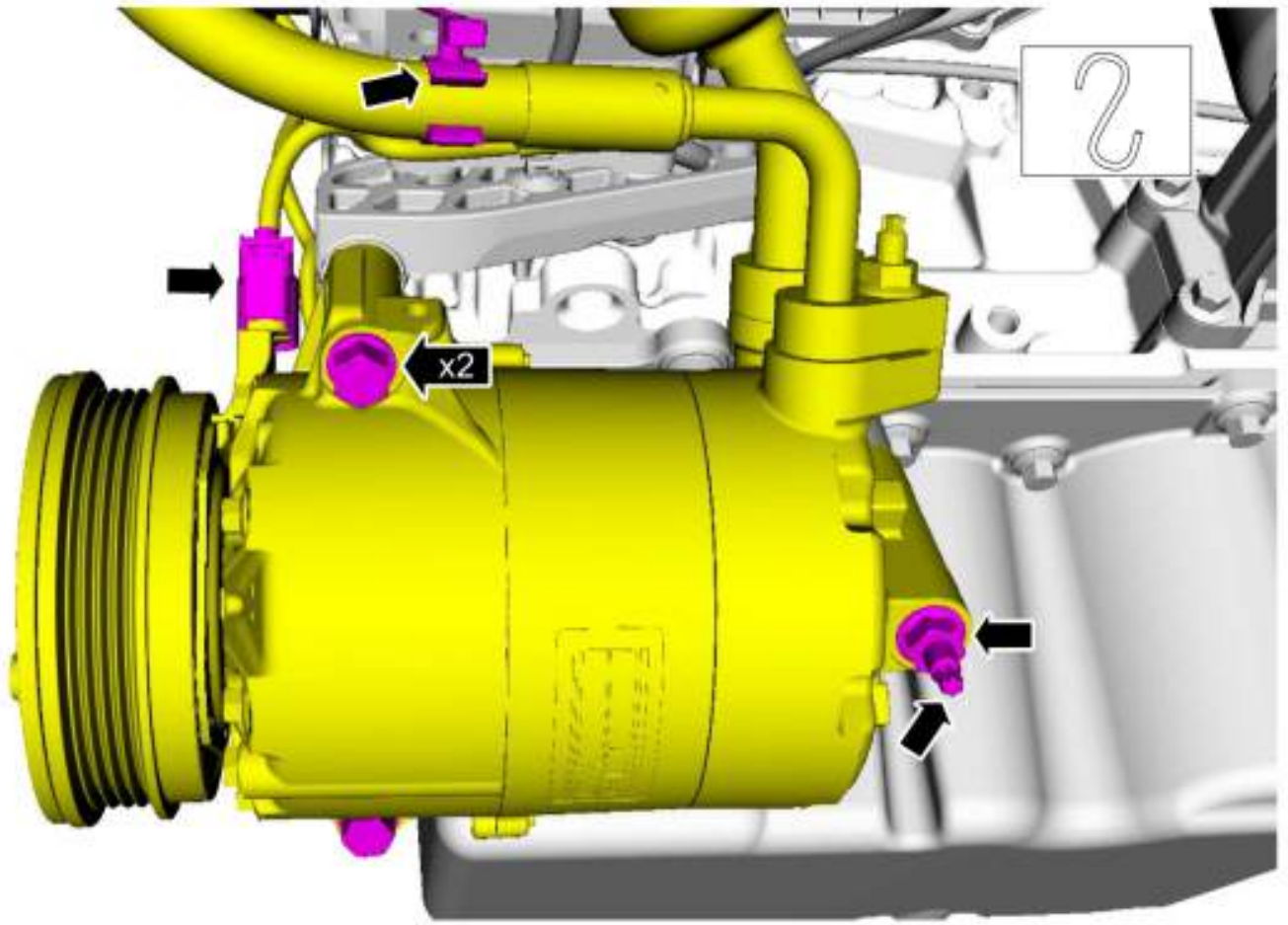

E164277

9. Loosen: 3 turn(s)

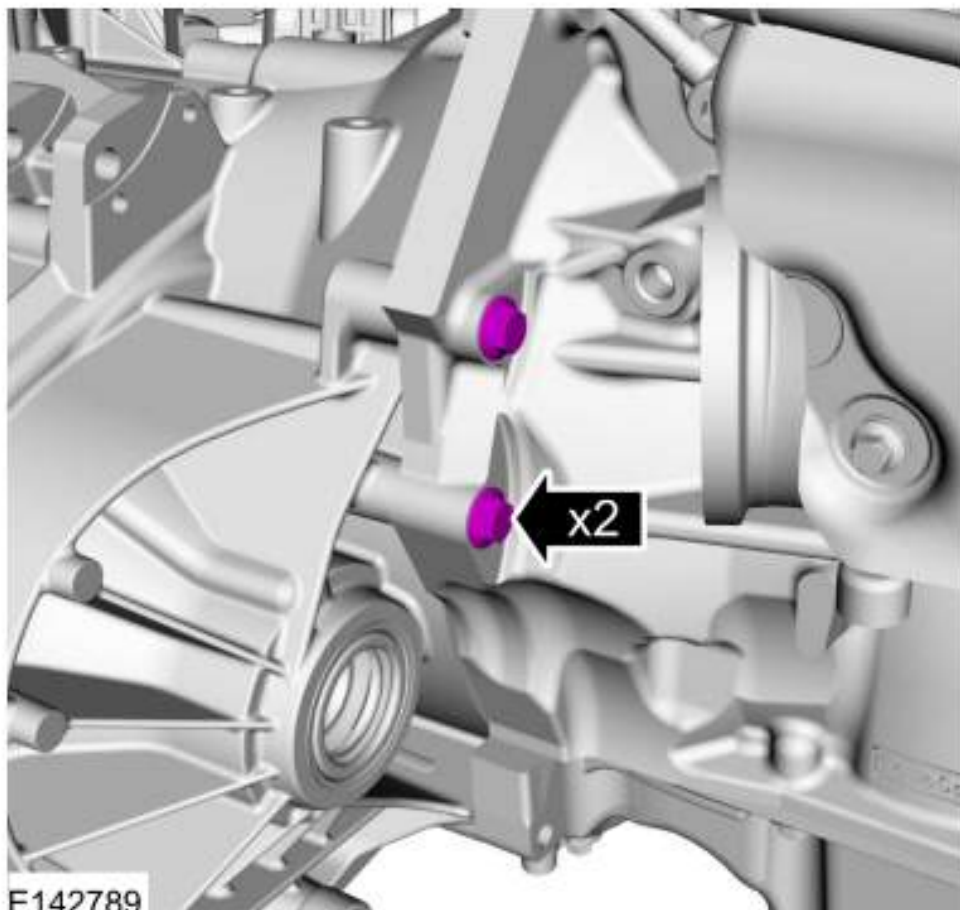

E142789



10.

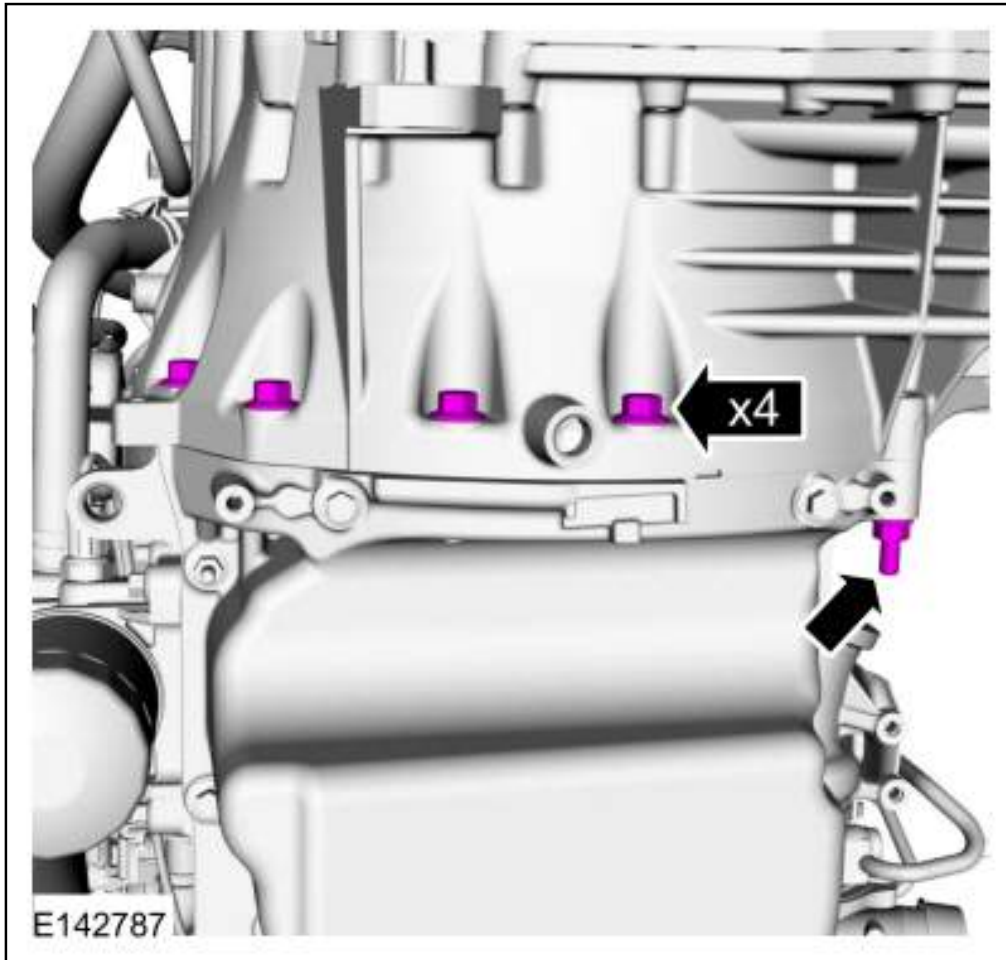

11.

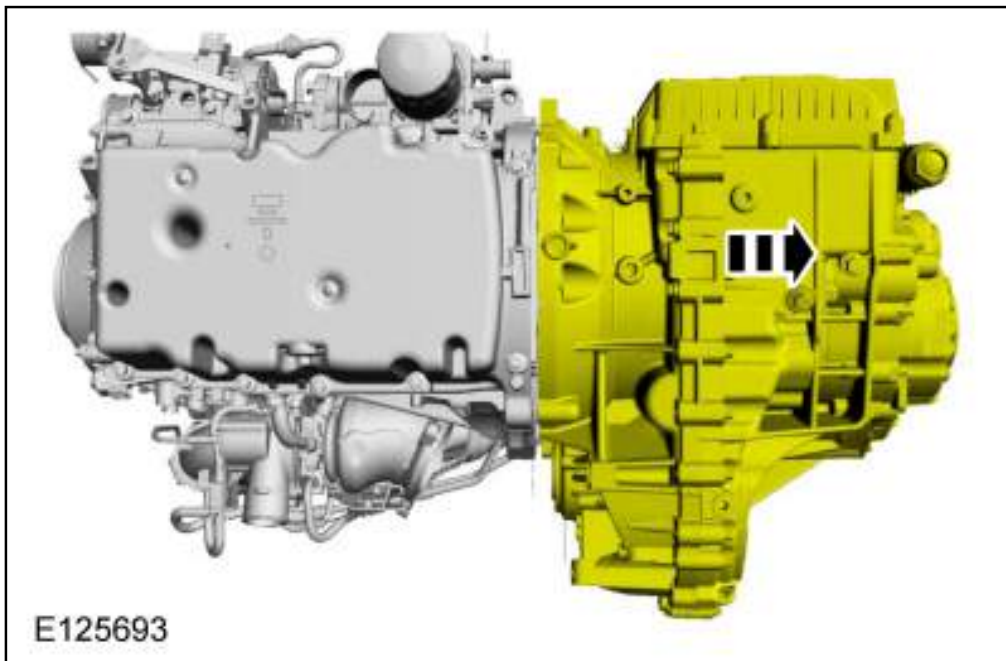

12.

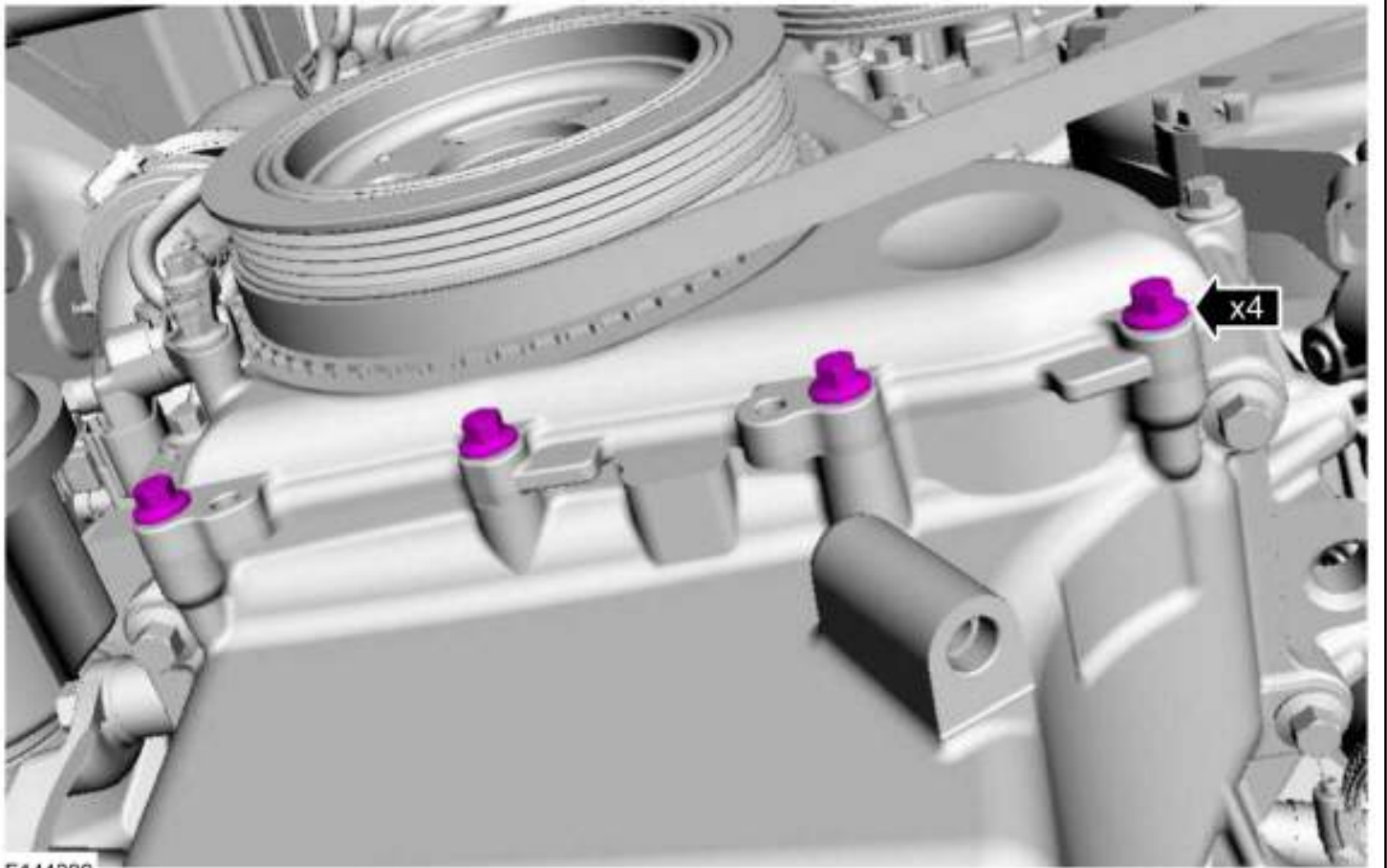

E144399



13.

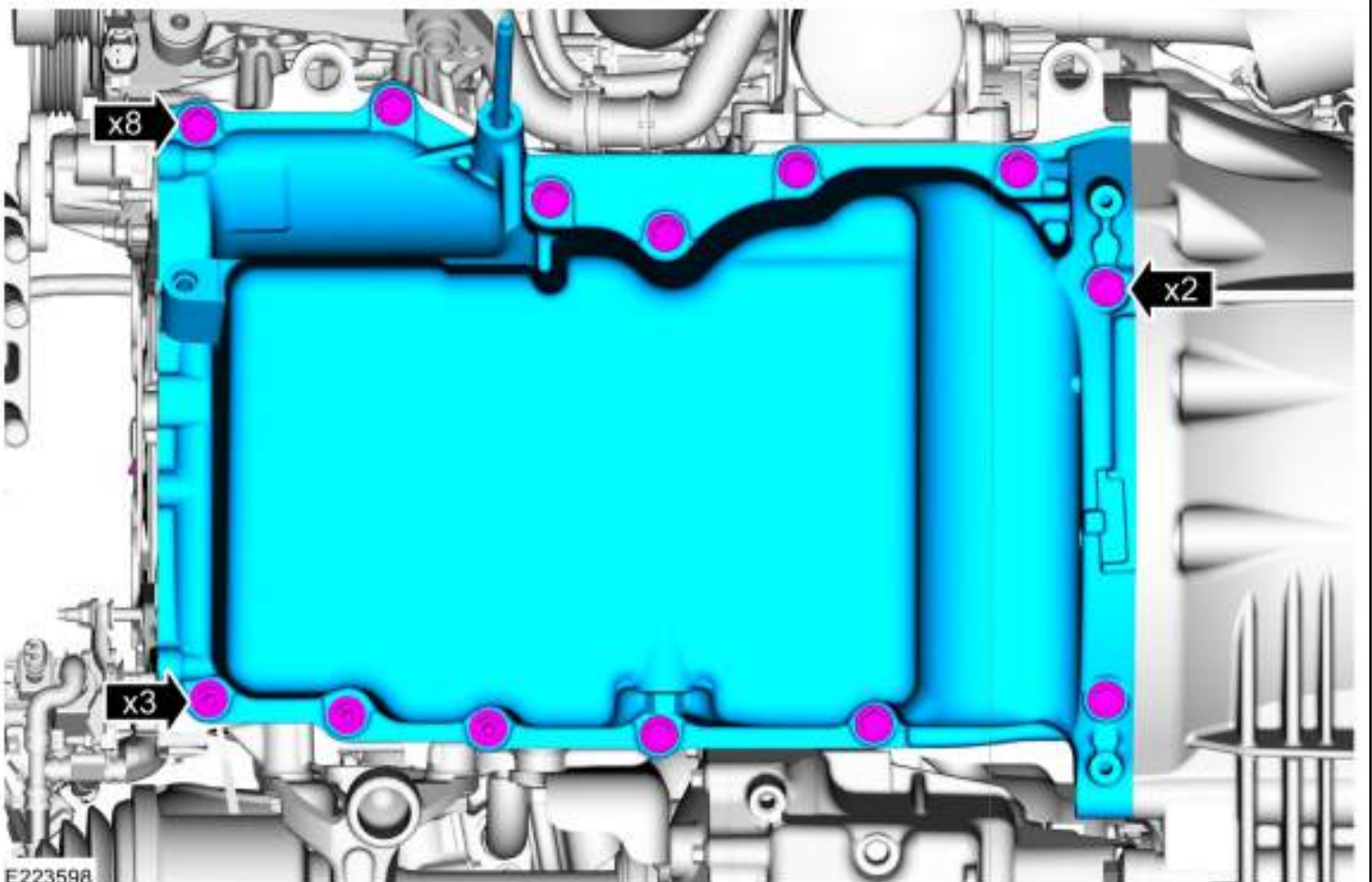

E223598



**Installation**

1. **NOTE:** Make sure that the mating faces are clean and free of foreign material.

Use the General Equipment: Plastic Scraper  
Material: Motorcraft® Metal Surface Prep Wipes / ZC-31-B

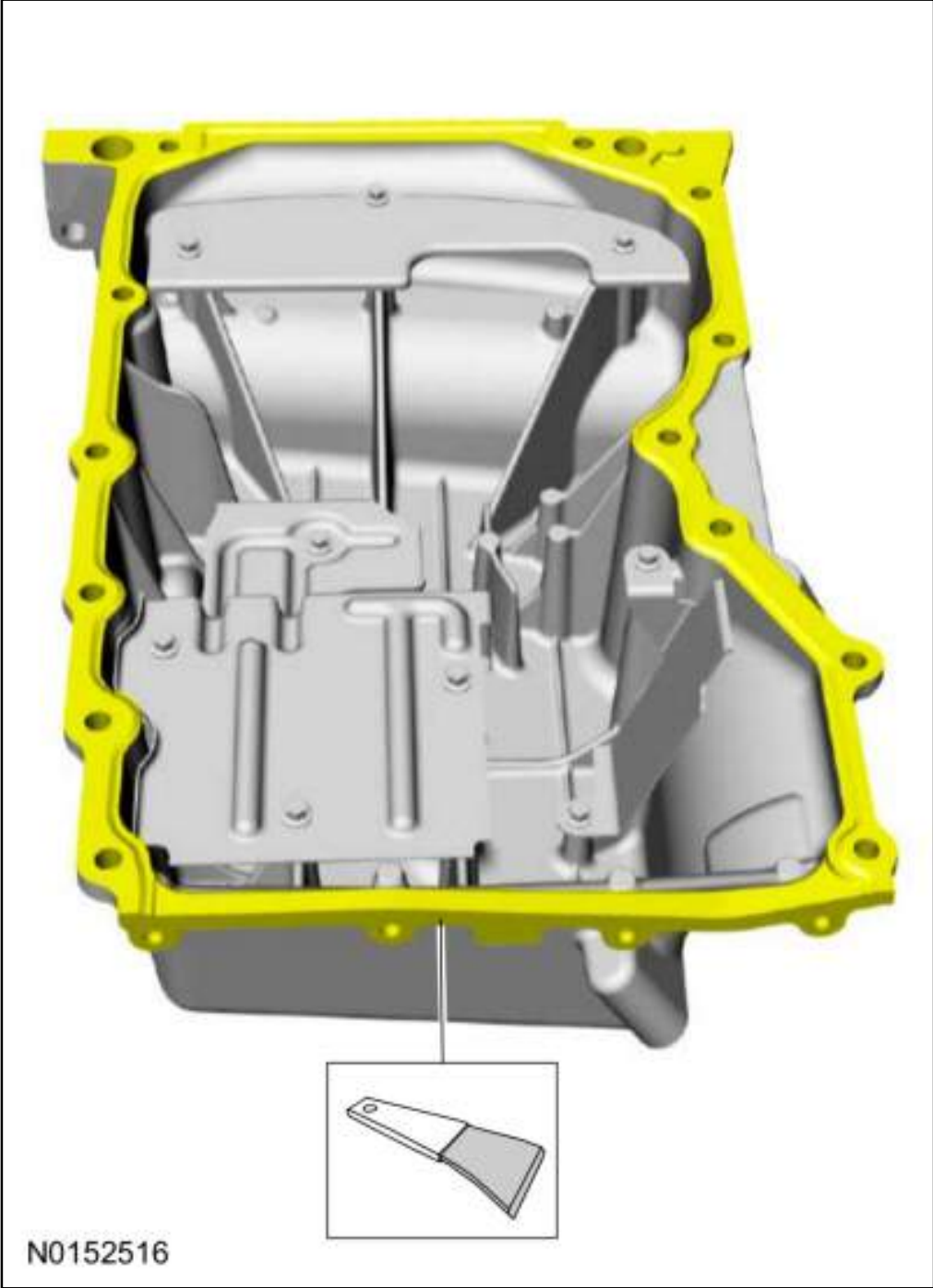

2. **NOTE:** Make sure that the mating faces are clean and free of foreign material.

Use the General Equipment: Plastic Scraper  
Material: Motorcraft® Metal Surface Prep Wipes / ZC-31-B

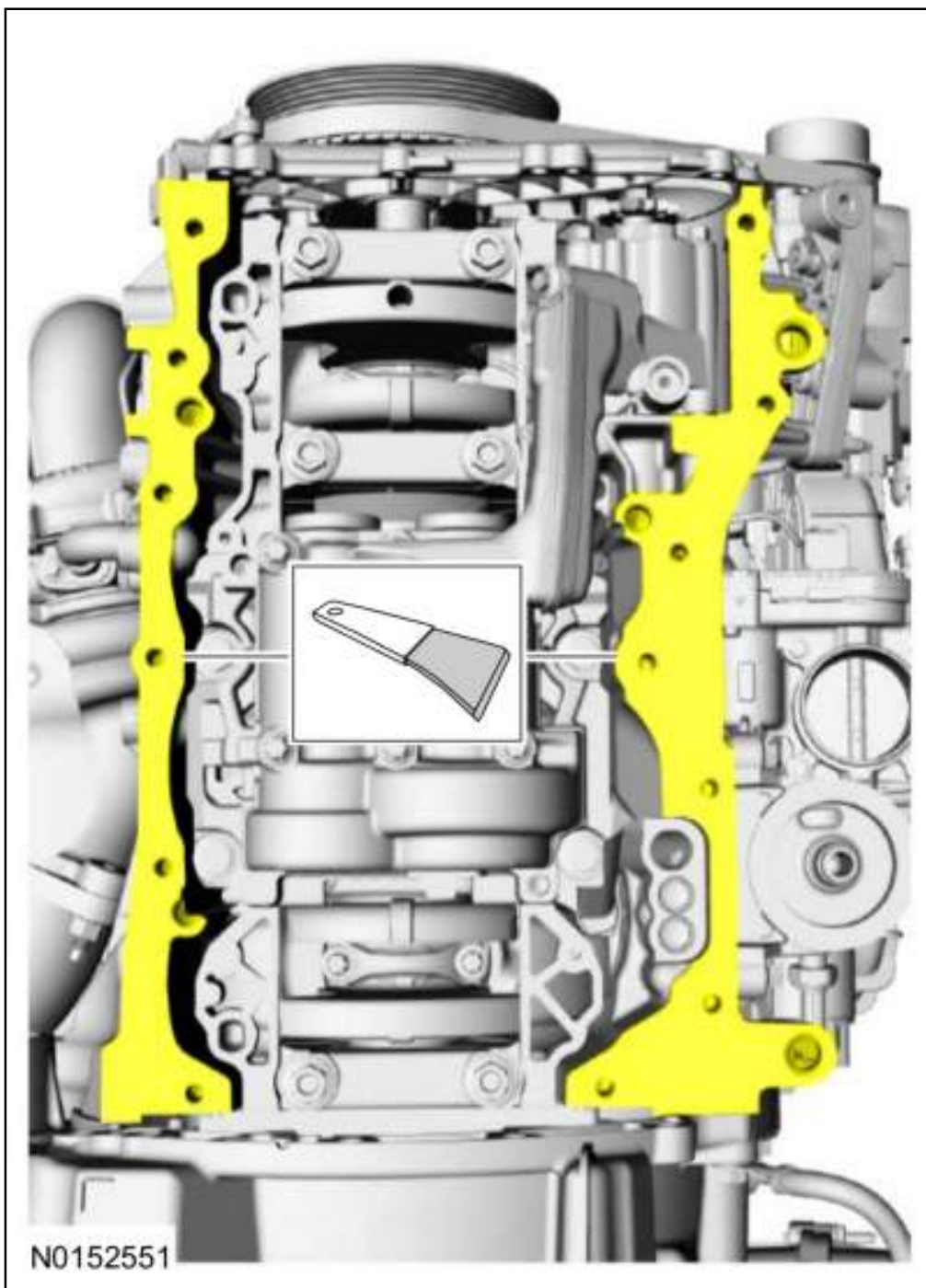

3. **NOTE:** Make sure that the mating faces are clean and free of foreign material.

Use the General Equipment: Plastic Scraper

Material: Motorcraft® Metal Surface Prep Wipes / ZC-31-B

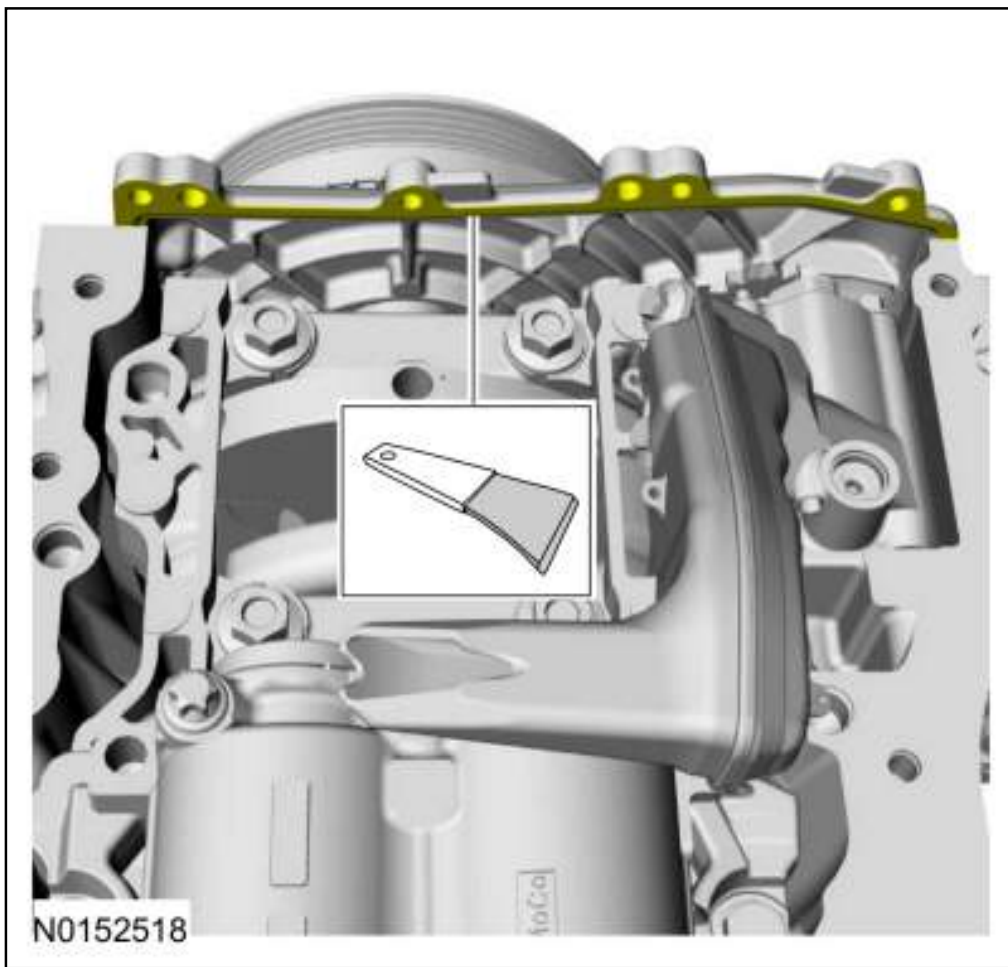

4. **NOTE:** *The component must be installed within 10 minutes of applying the sealant.*

*Material:* Motorcraft® Silicone Gasket and Sealant / TA-30 (WSE-M4G323-A4)

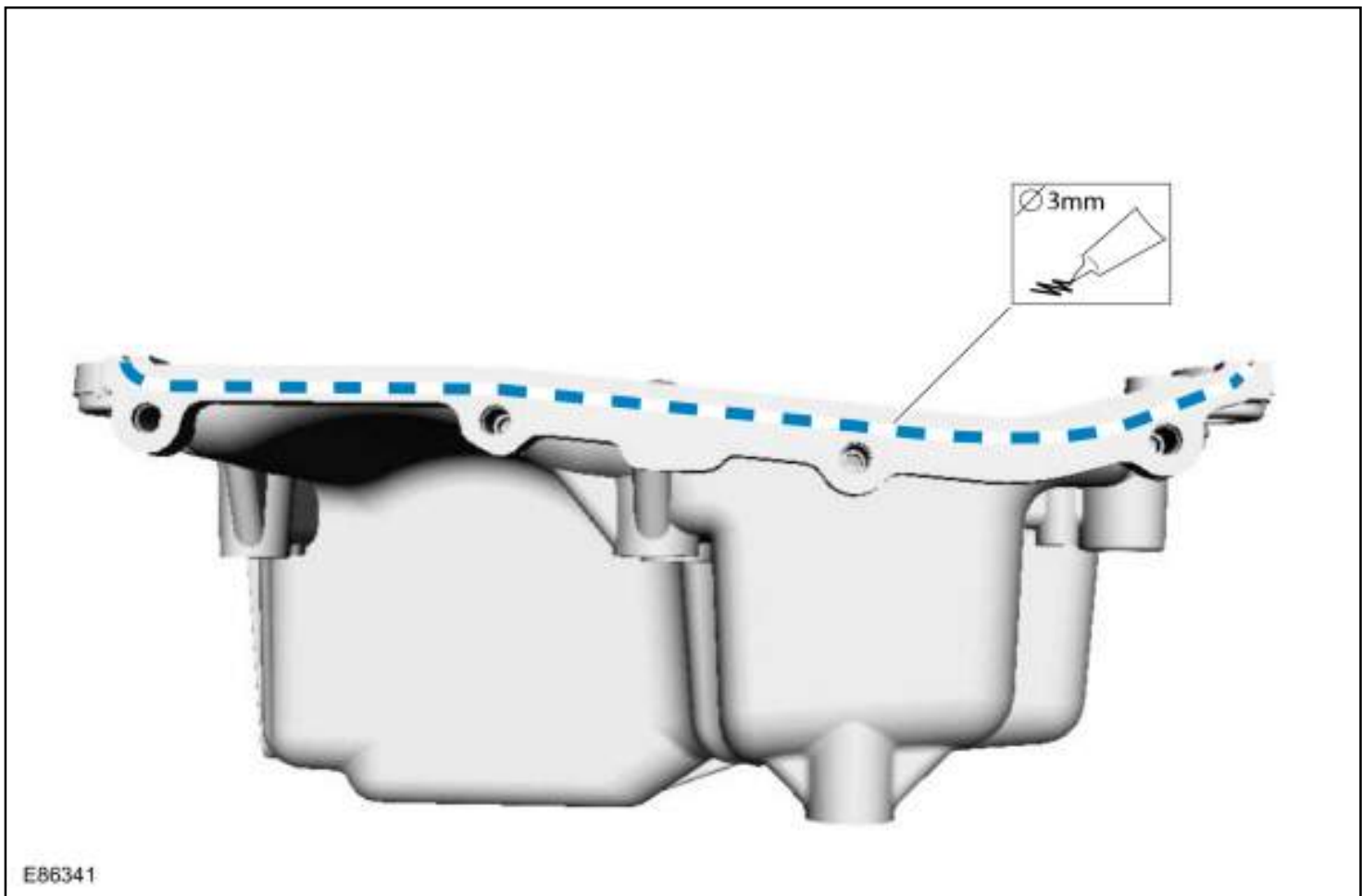

5. **NOTE:** *The component must be installed within 10 minutes of applying the sealant.*

*Material:* Motorcraft® Silicone Gasket and Sealant / TA-30 (WSE-M4G323-A4)

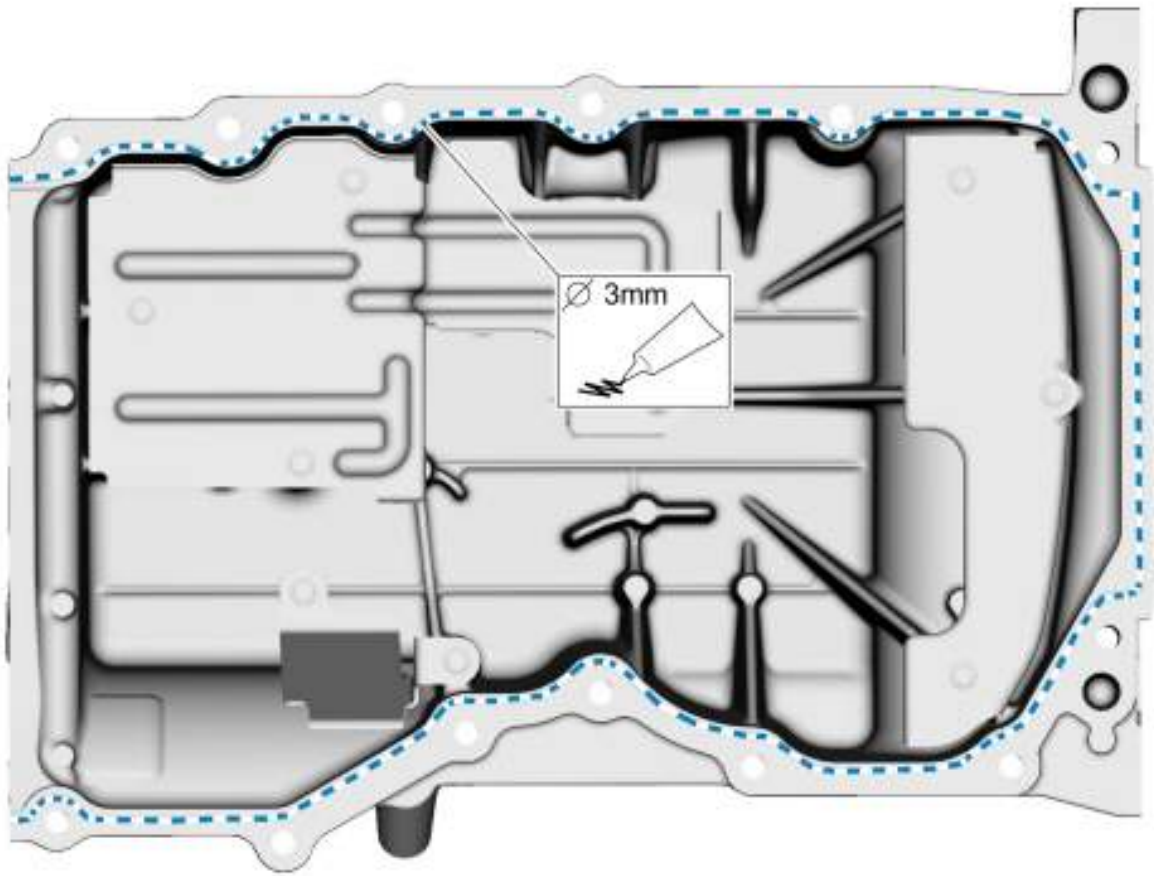

E144415

6. **NOTE:** Only tighten the bolts finger tight at this stage.

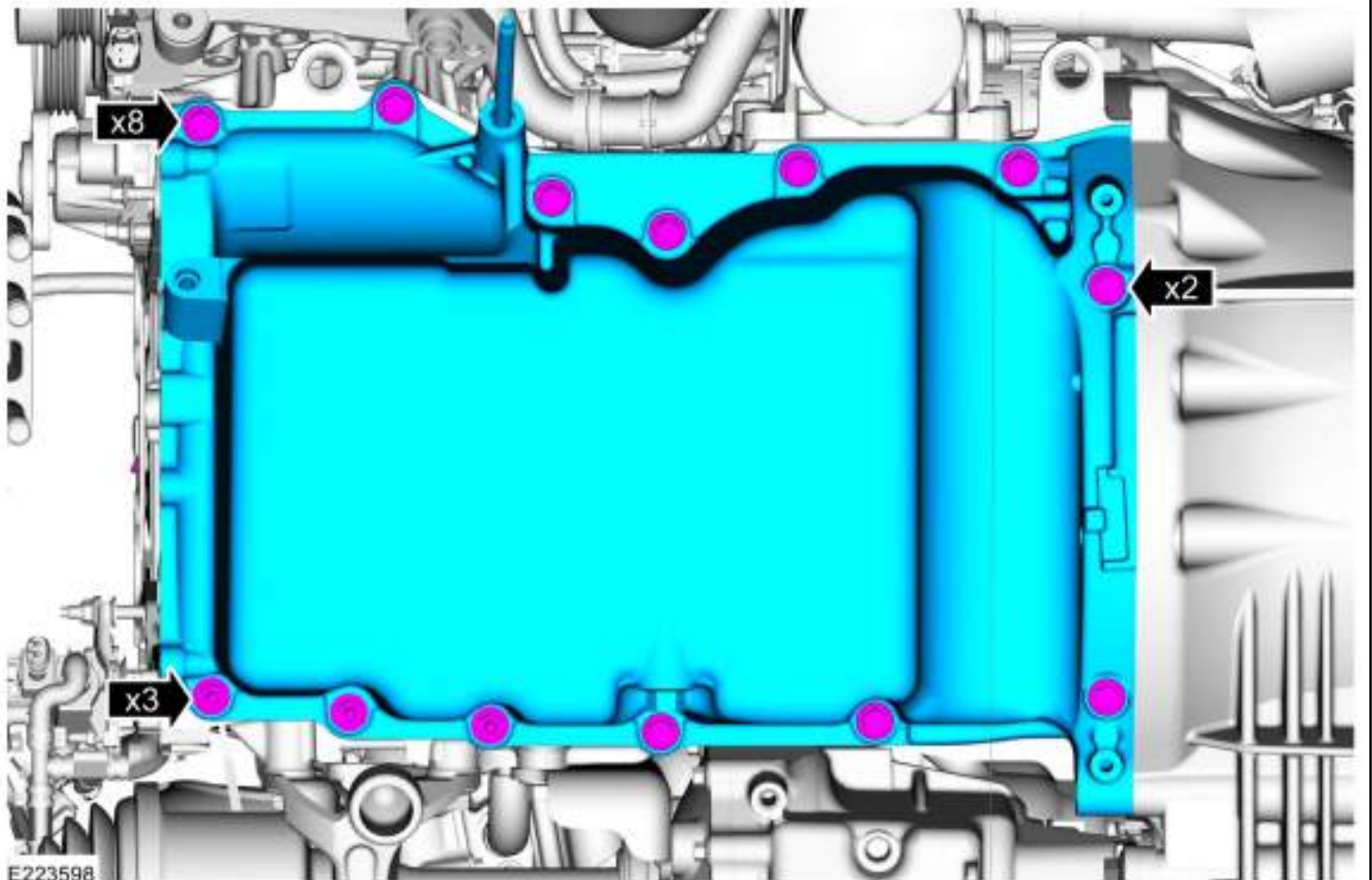

E223598



7. *Torque:* 89 lb.in (10 Nm)

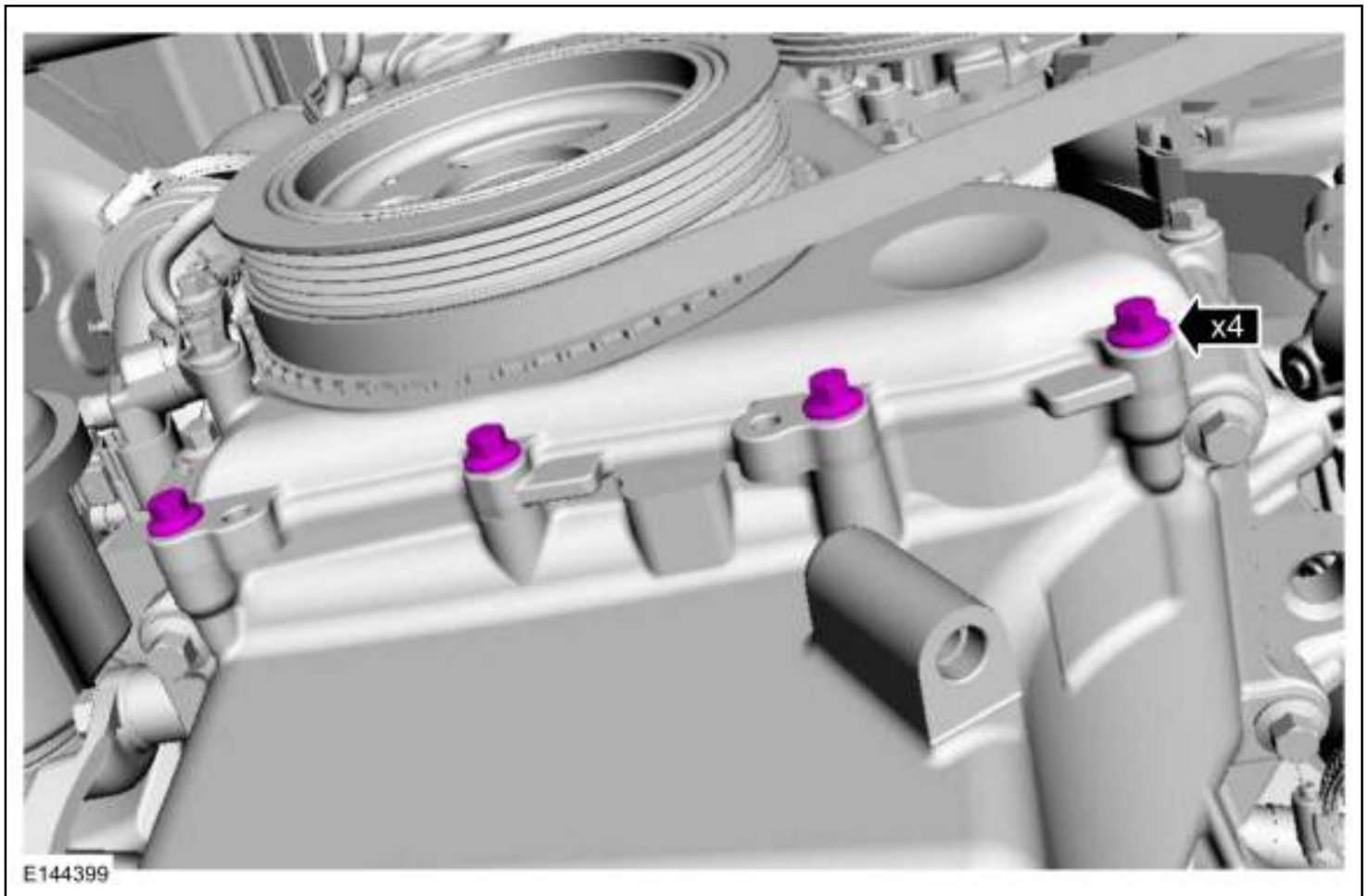

8. *Torque:* 177 lb.in (20 Nm)

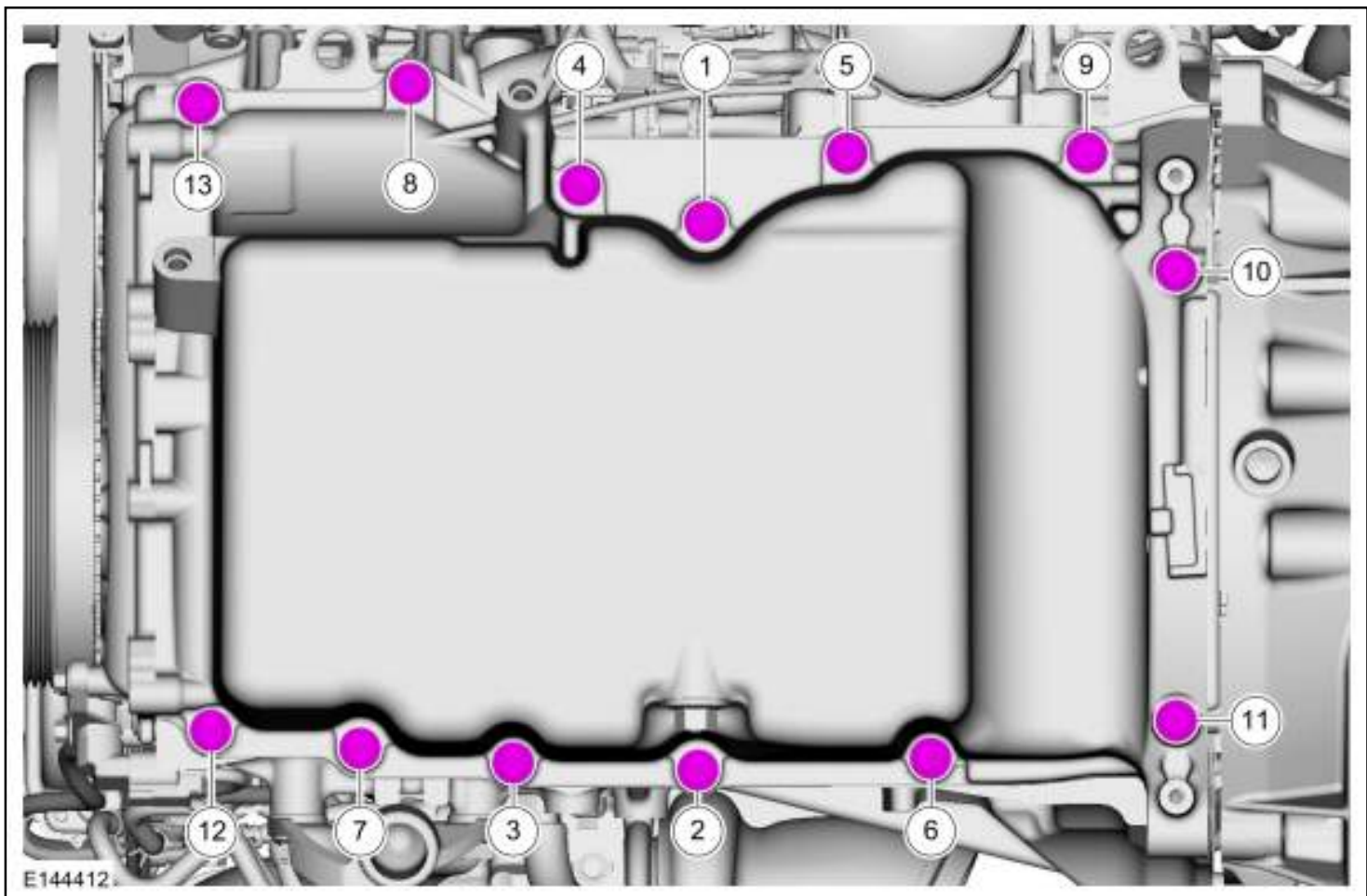

9. Torque: 35 lb.ft (48 Nm)

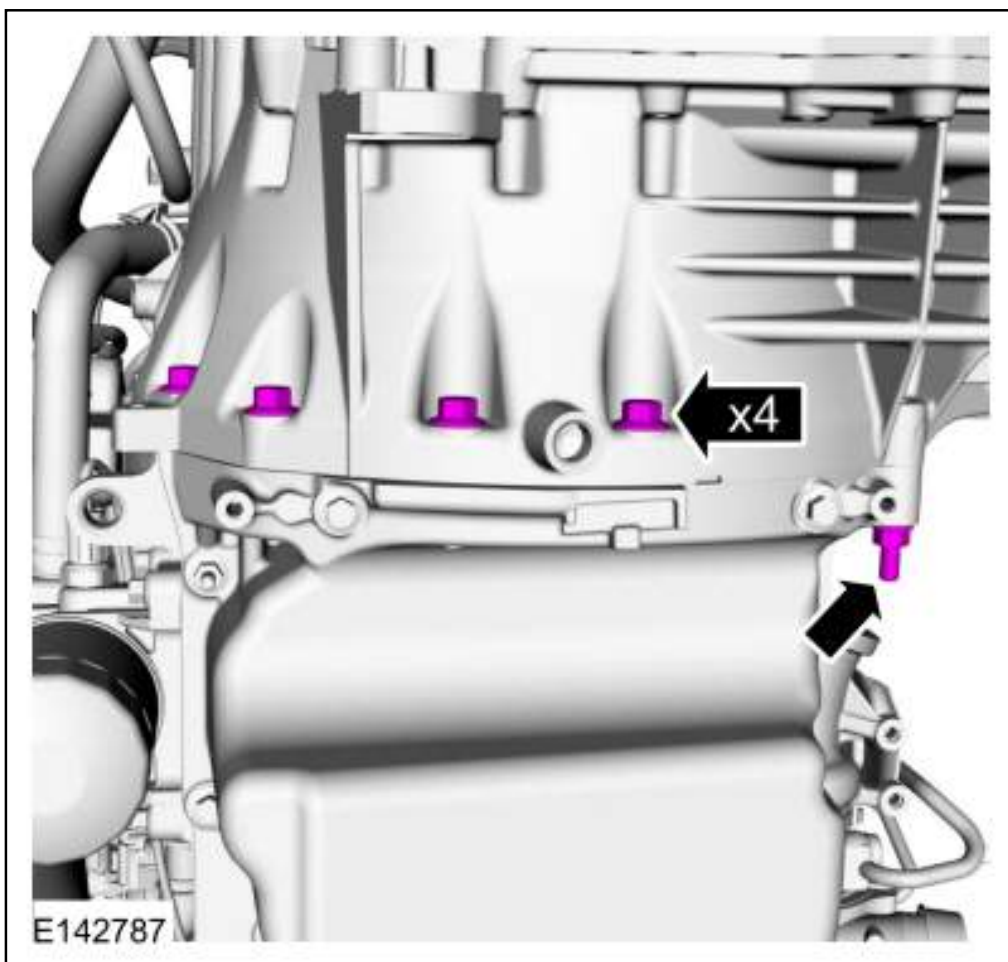

10. *Torque: 35 lb.ft (48 Nm)*

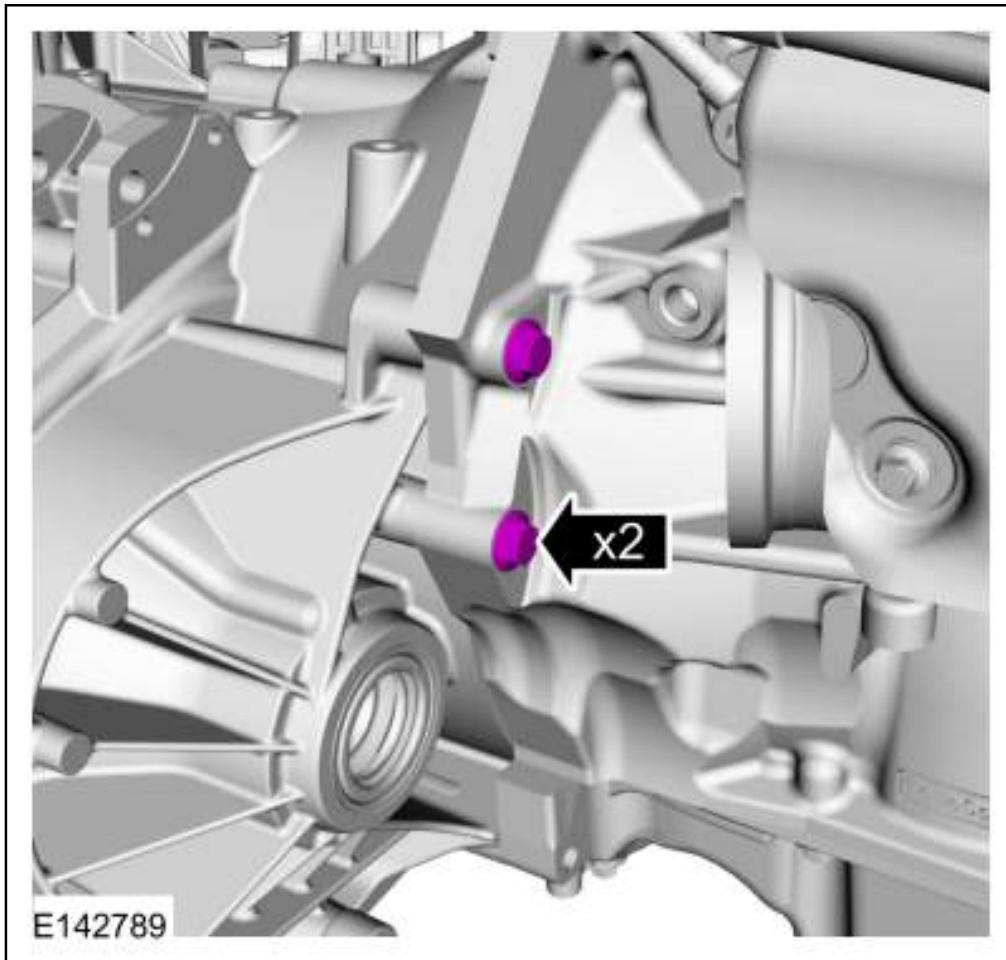

11. **NOTICE:** Make sure that no strain is placed on the refrigerant lines.

*Torque: 18 lb.ft (25 Nm)*

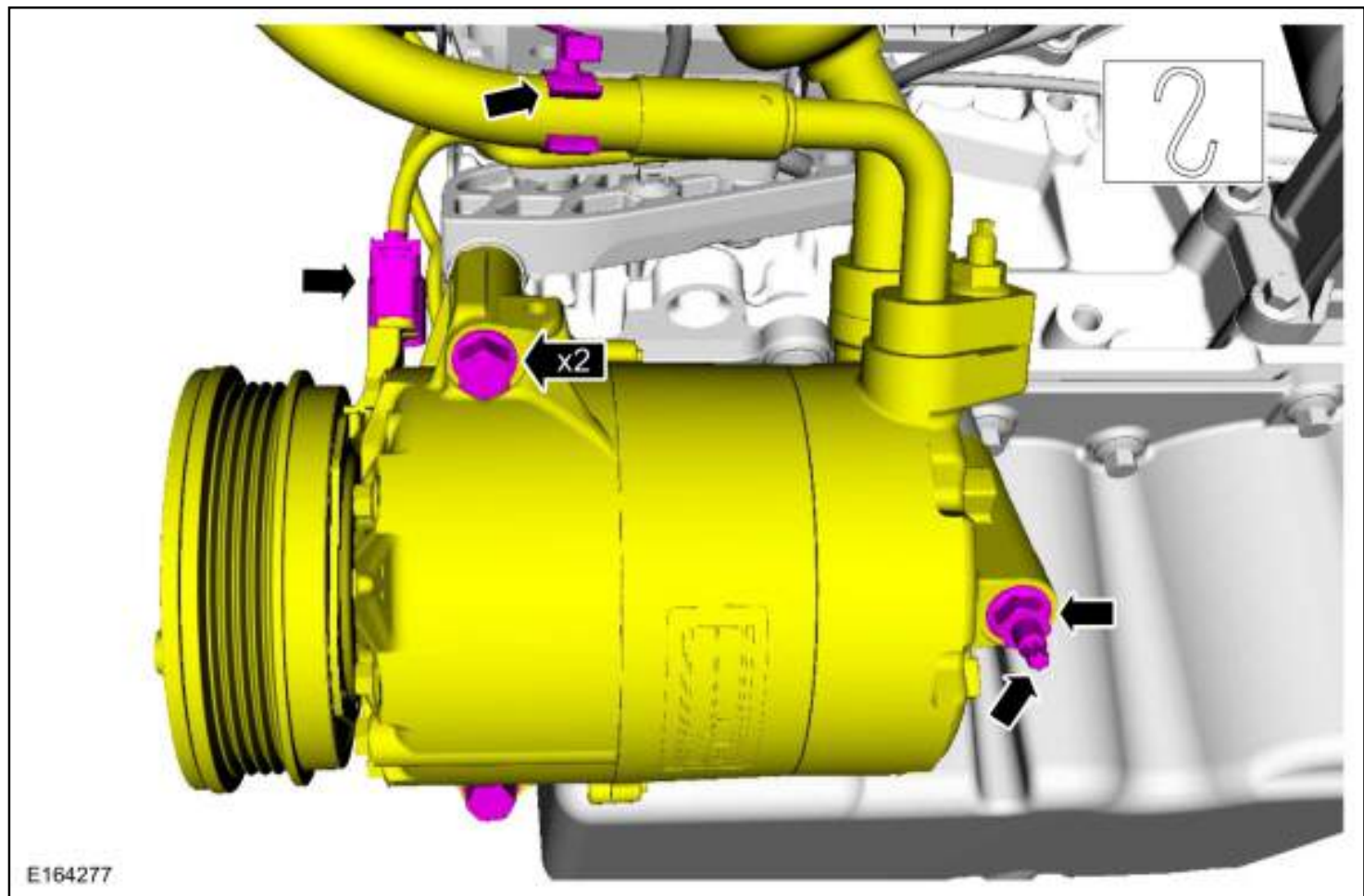

12. *Torque:* 35 lb.ft (48 Nm)

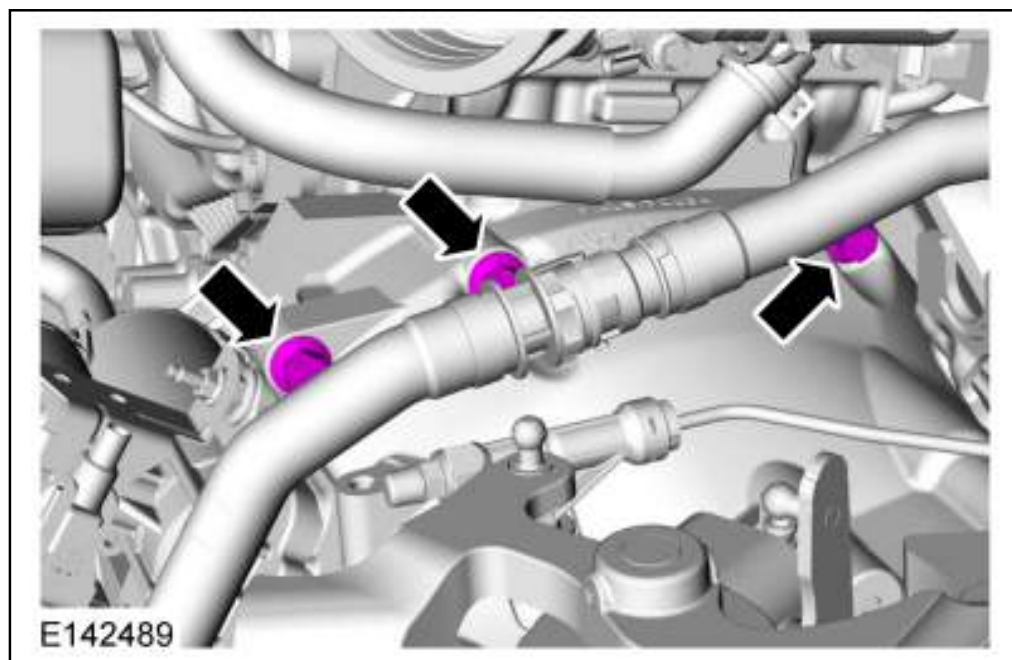

13. *Torque:* 30 lb.ft (40 Nm)

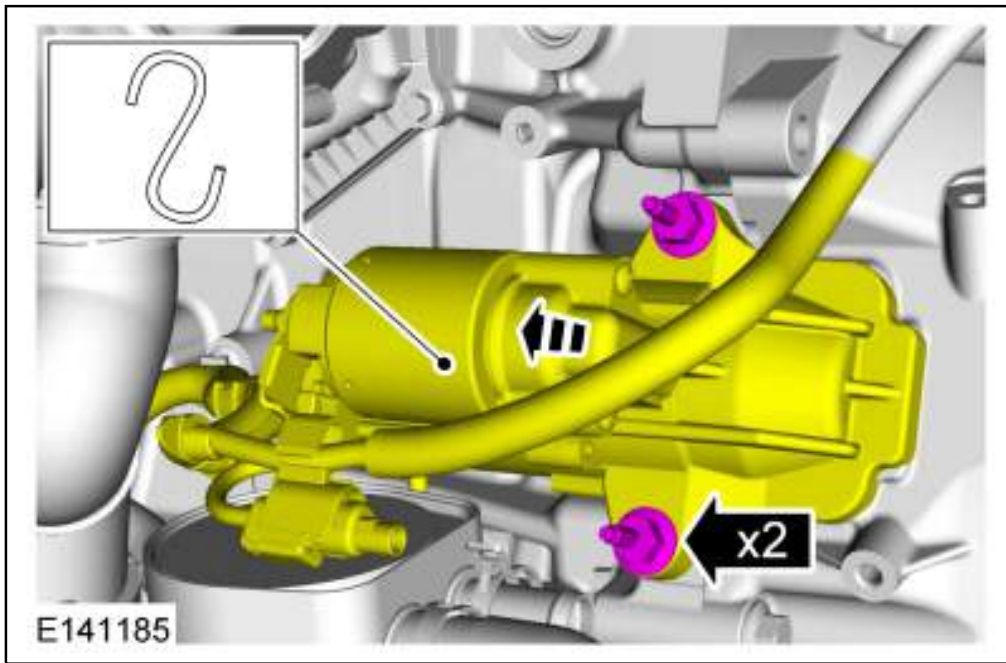

14. *Torque: 18 lb.ft (25 Nm)*

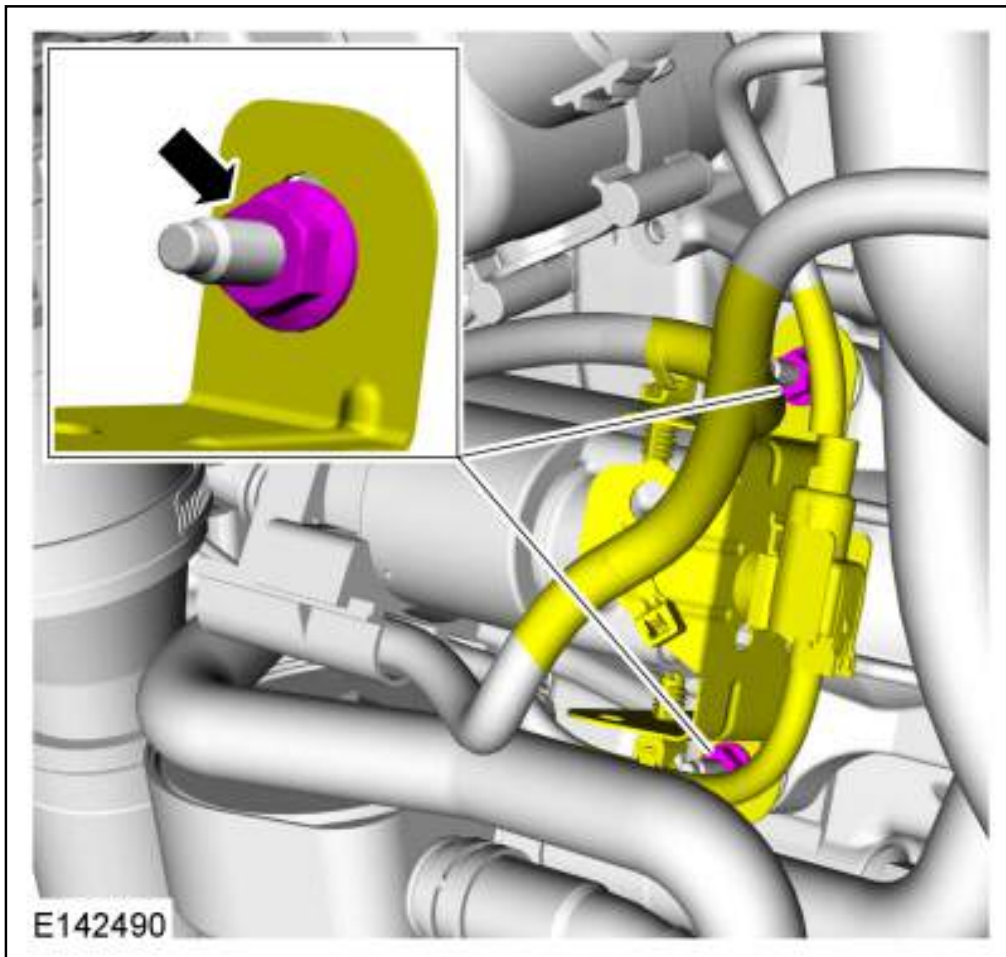

15. **NOTE:** *Component must be lubricated with clean engine oil.*

**NOTE:** *Make sure that a new component is installed.*

*Torque: 133 lb.in (15 Nm)*

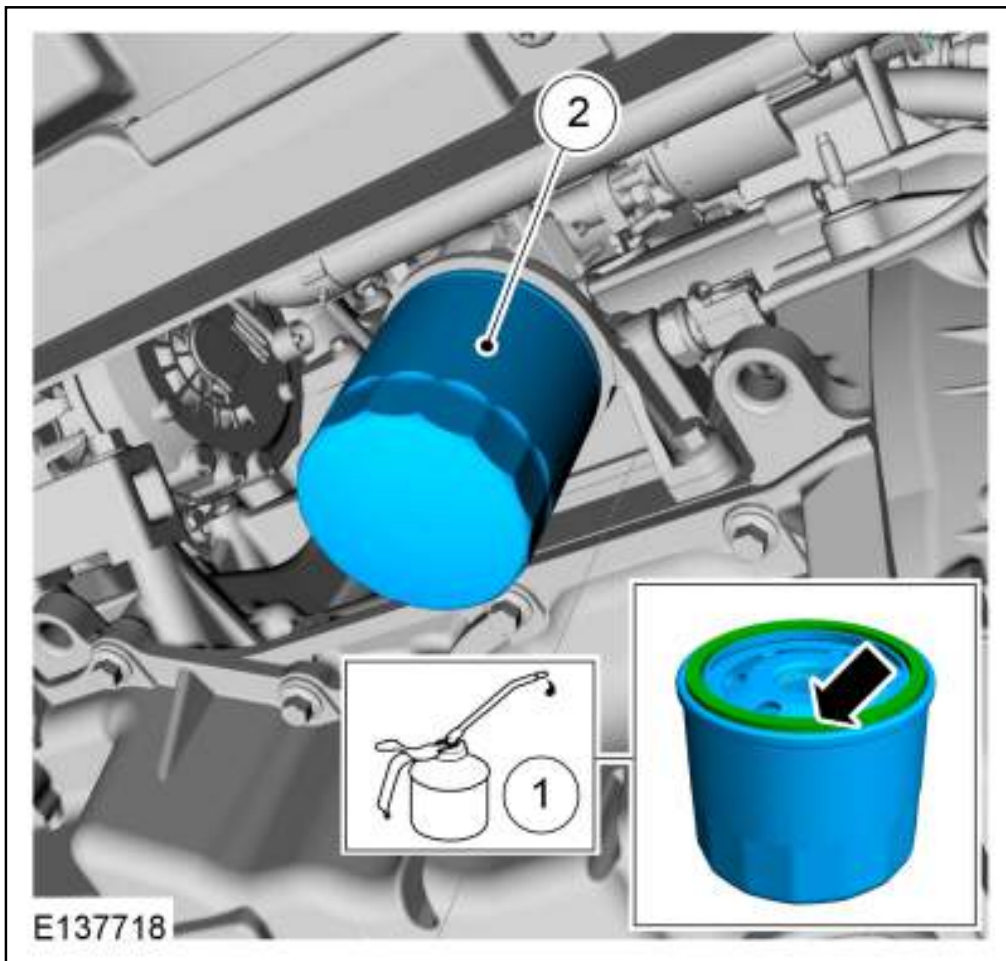

16. Install the following items:

1. Refer to: Transfer Case (308-07 Transfer Case) .
2. Refer to: Air Conditioning (A/C) Compressor Belt (303-05 Accessory Drive - 2.3L EcoBoost (257kW/350PS) - MI4) .

17. Refer to: [Specifications](#) (303-01E Engine - 2.3L EcoBoost (257kW/350PS) - MI4, Specifications).

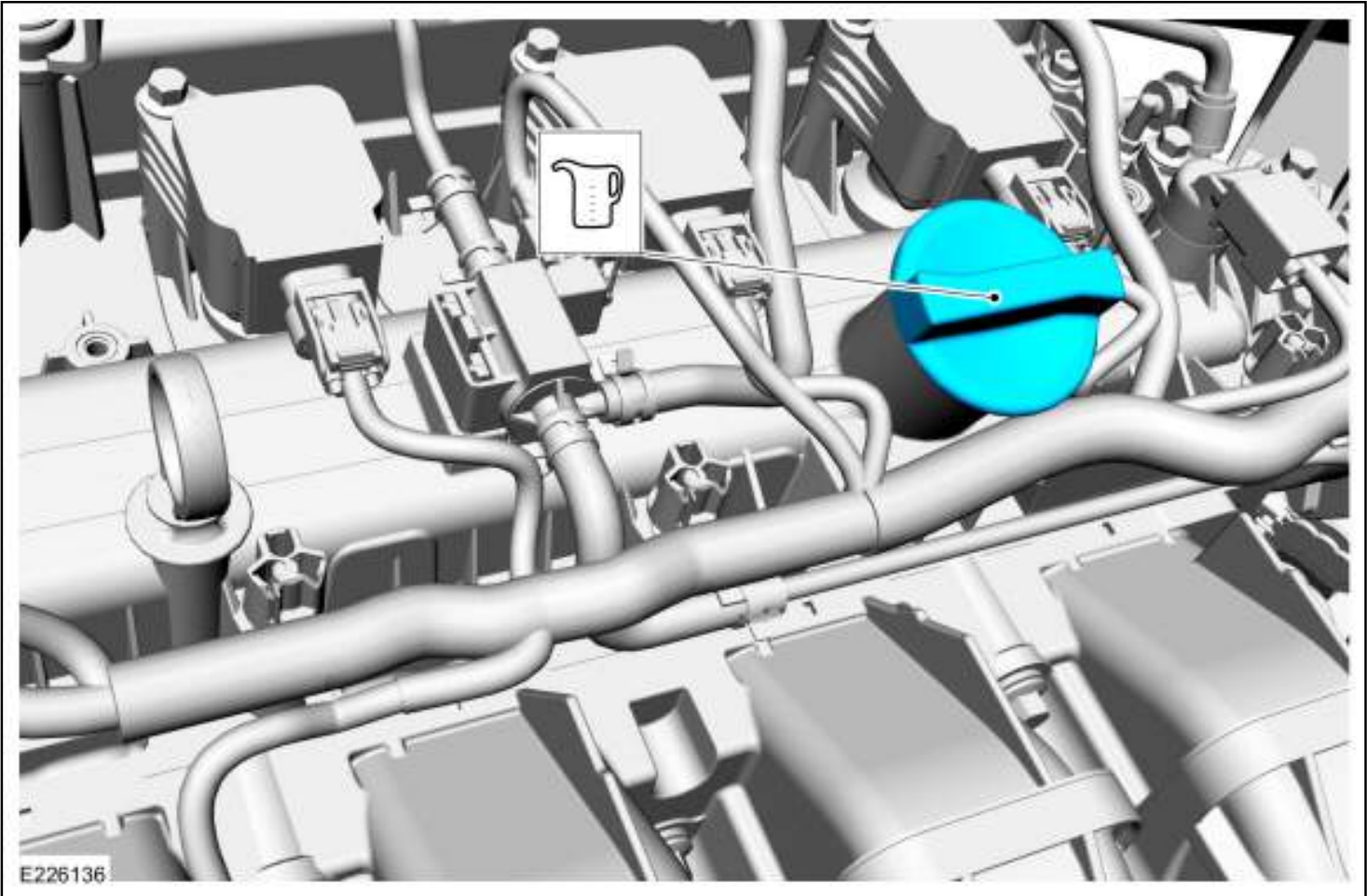

18.

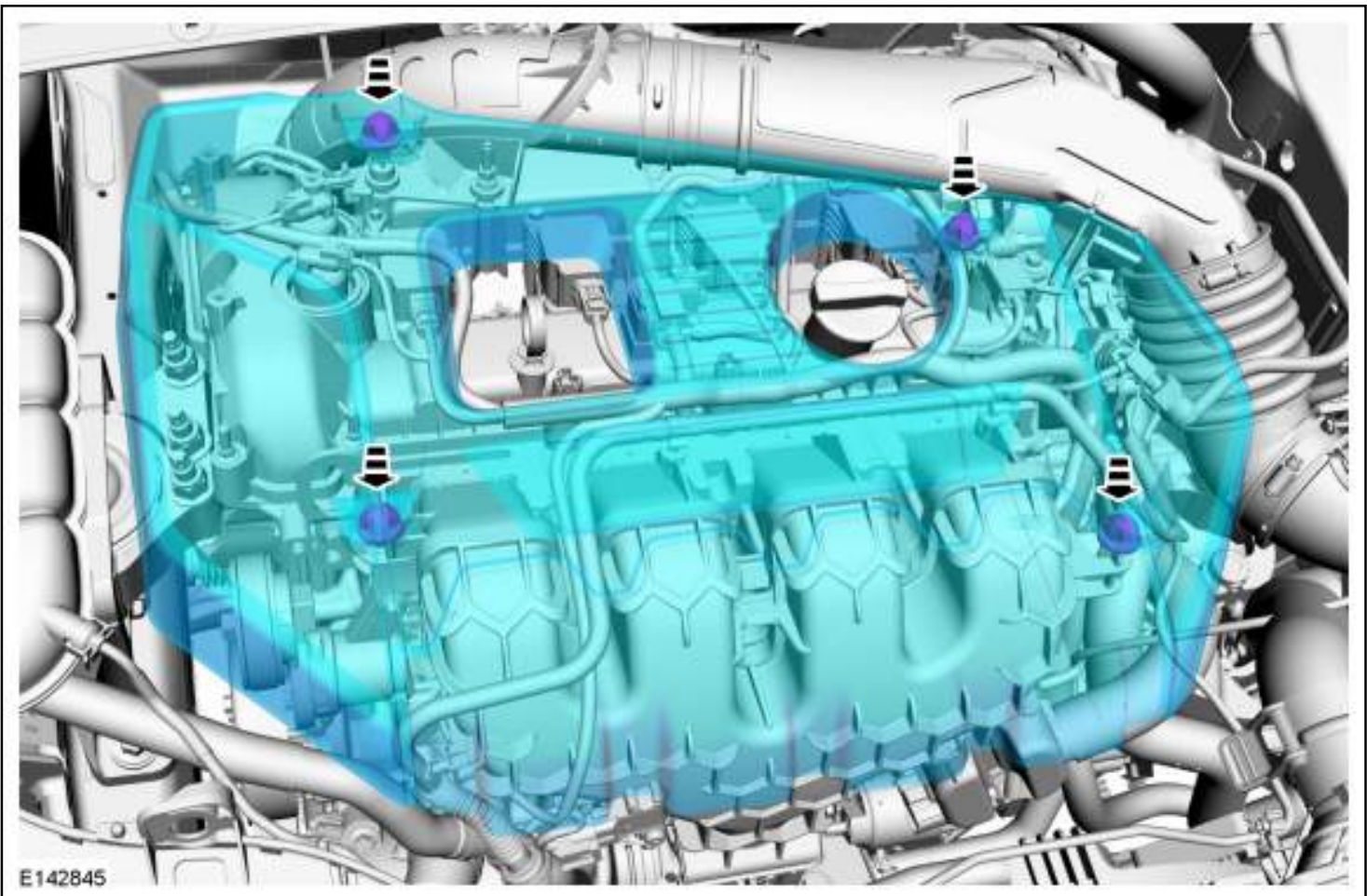

cardiagn.



## Oil Pressure Switch

### Removal

**NOTE:** Removal steps in this procedure may contain installation details.

1. Refer to: Jacking and Lifting (100-02 Jacking and Lifting) .
- 2.

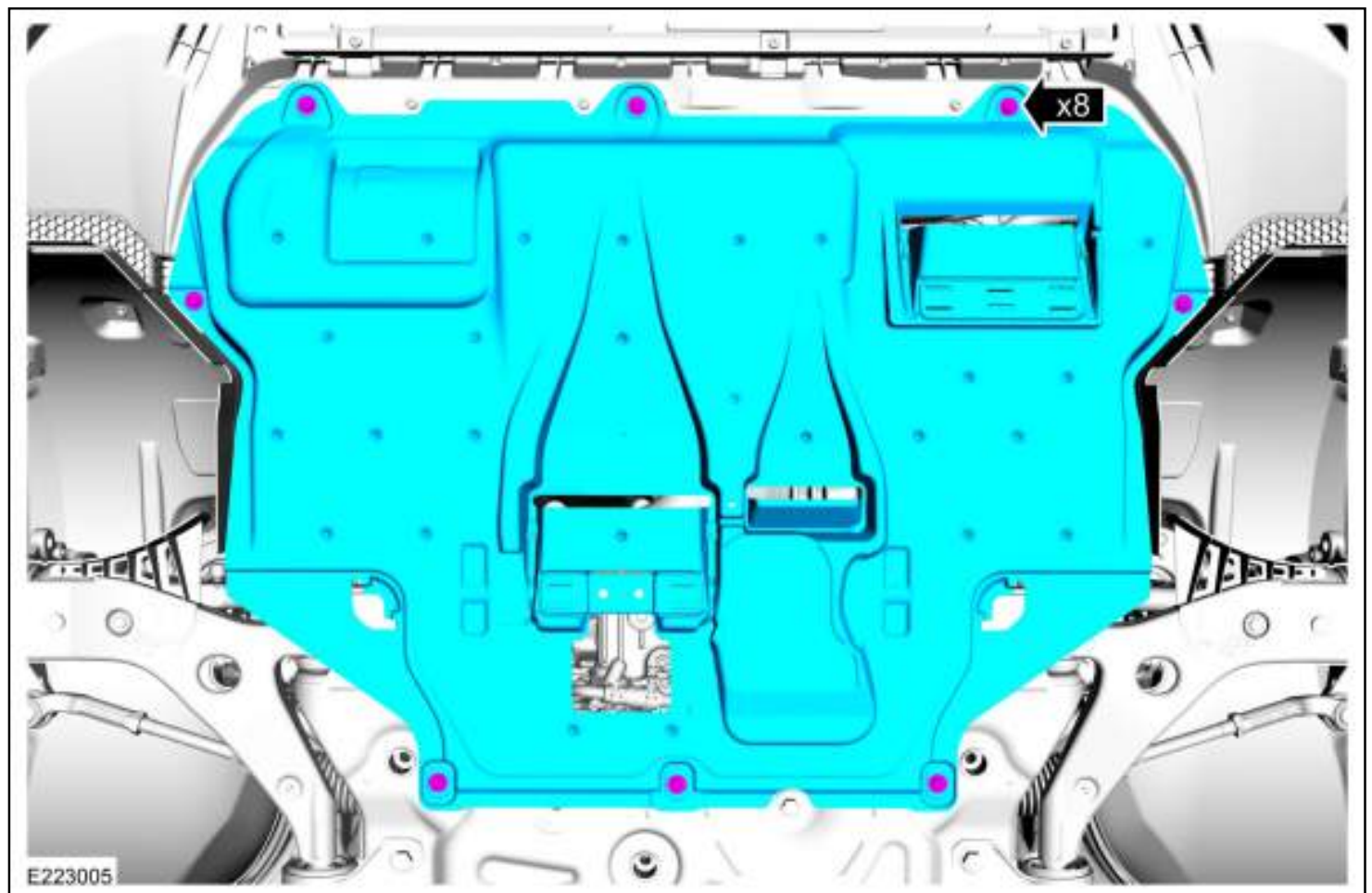

3. **NOTE:** Make sure that a new component is installed.

*Torque:* 133 lb.in (15 Nm)

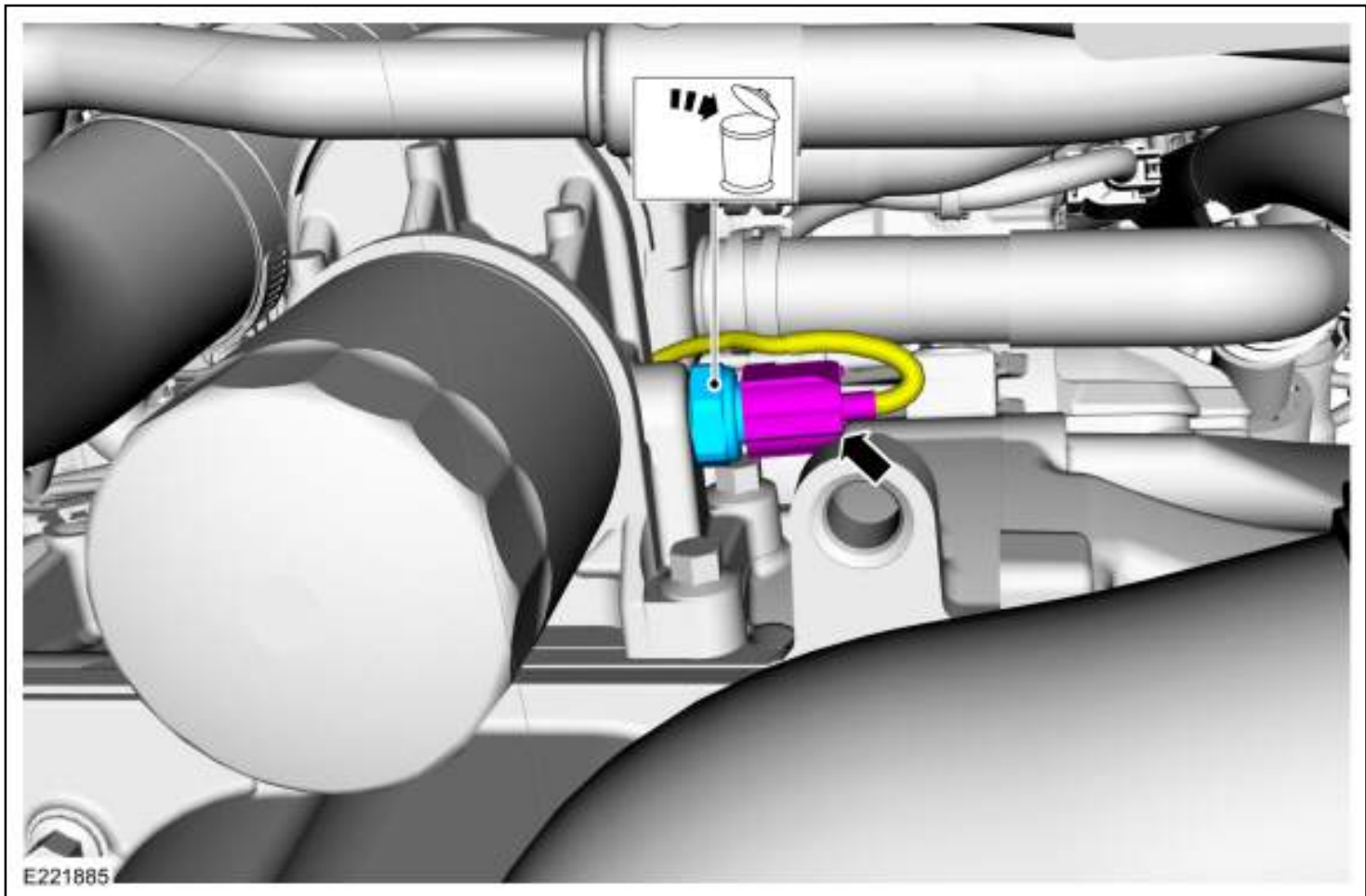

**Installation**





- 1. To install, reverse the removal procedure.

Copyright © 2019 Ford Motor Company

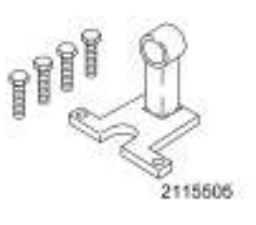

## Valve Stem Seals

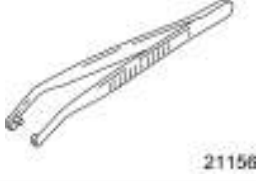
### Special Tool(s) / General Equipment

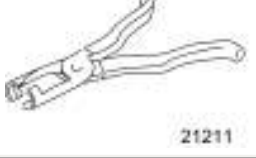
 2115502A	303-361-02 Adapter for 303-361A
 2115505	303-361-05 Adapter for 303-361A
 E62757	303-361B Compressor, Valve Spring
 21158	303-362 Installer, Valve Stem Collets
 21157	303-363 Adapter, Air Supply (Cylinder Head)
 21211	303-508 Pliers, Valve Stem Seal

cardiagn.com

### Removal

**NOTE:** Removal steps in this procedure may contain installation details.

1. Refer to: [Camshafts](#) (303-01C Engine, Removal and Installation).

2. **NOTE:** Note the position of the components before removal.

**NOTE:** Make sure that the components are installed to the position noted before removal.

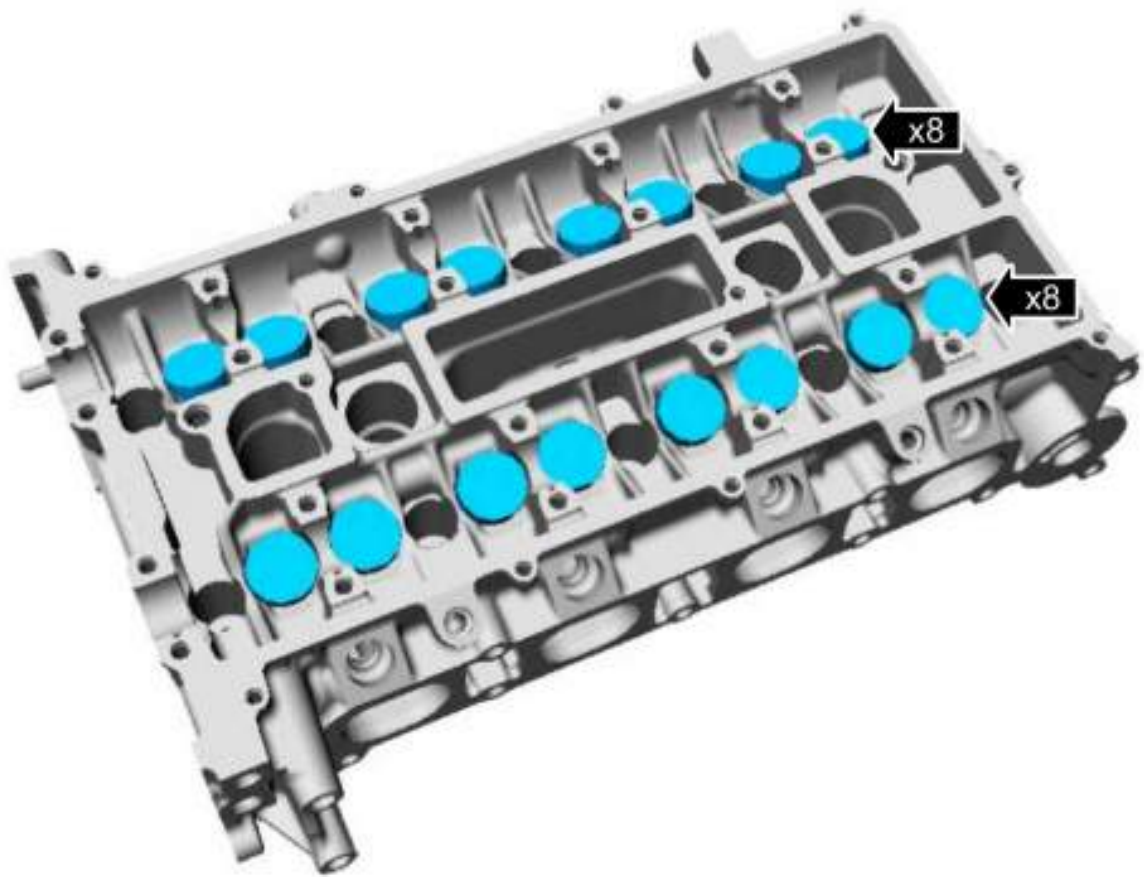

E66111



3. Use Special Service Tool: 303-363 Adapter, Air Supply (Cylinder Head).

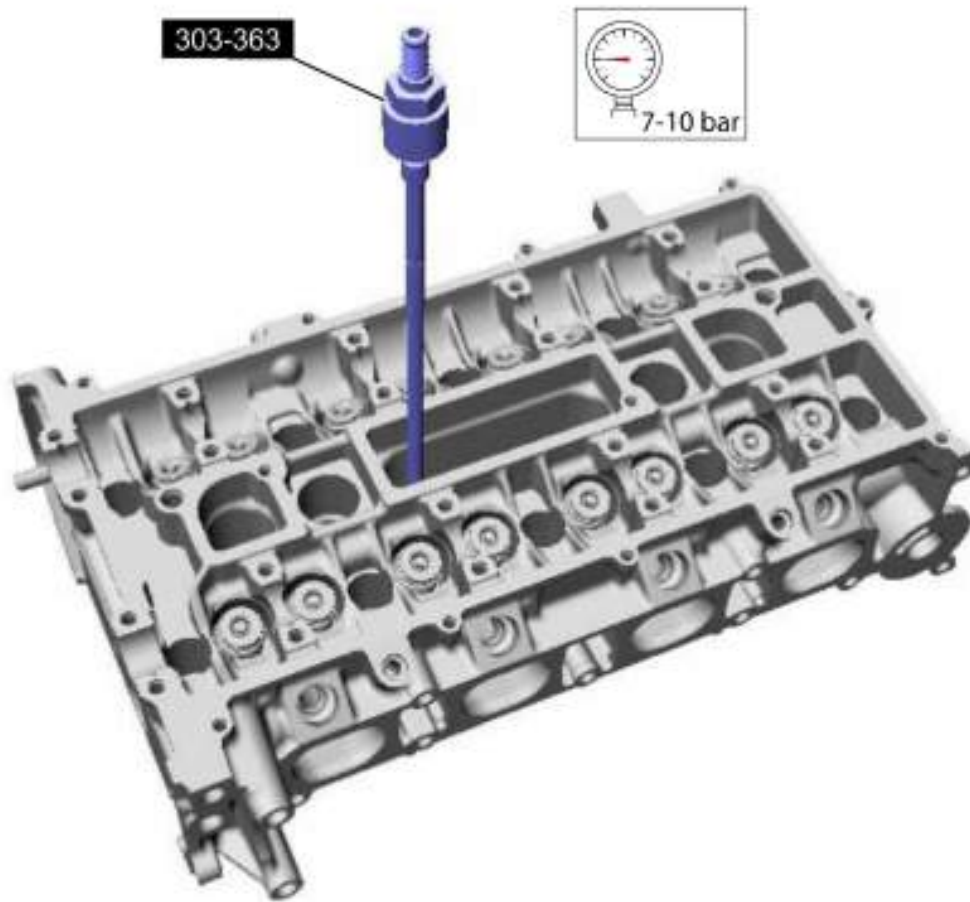

E66112

4. Use Special Service Tool: 303-361B Compressor, Valve Spring. , 303-361-02 Adapter for 303-361A. , 303-361-05 Adapter for 303-361A. , 303-362 Installer, Valve Stem Collets.



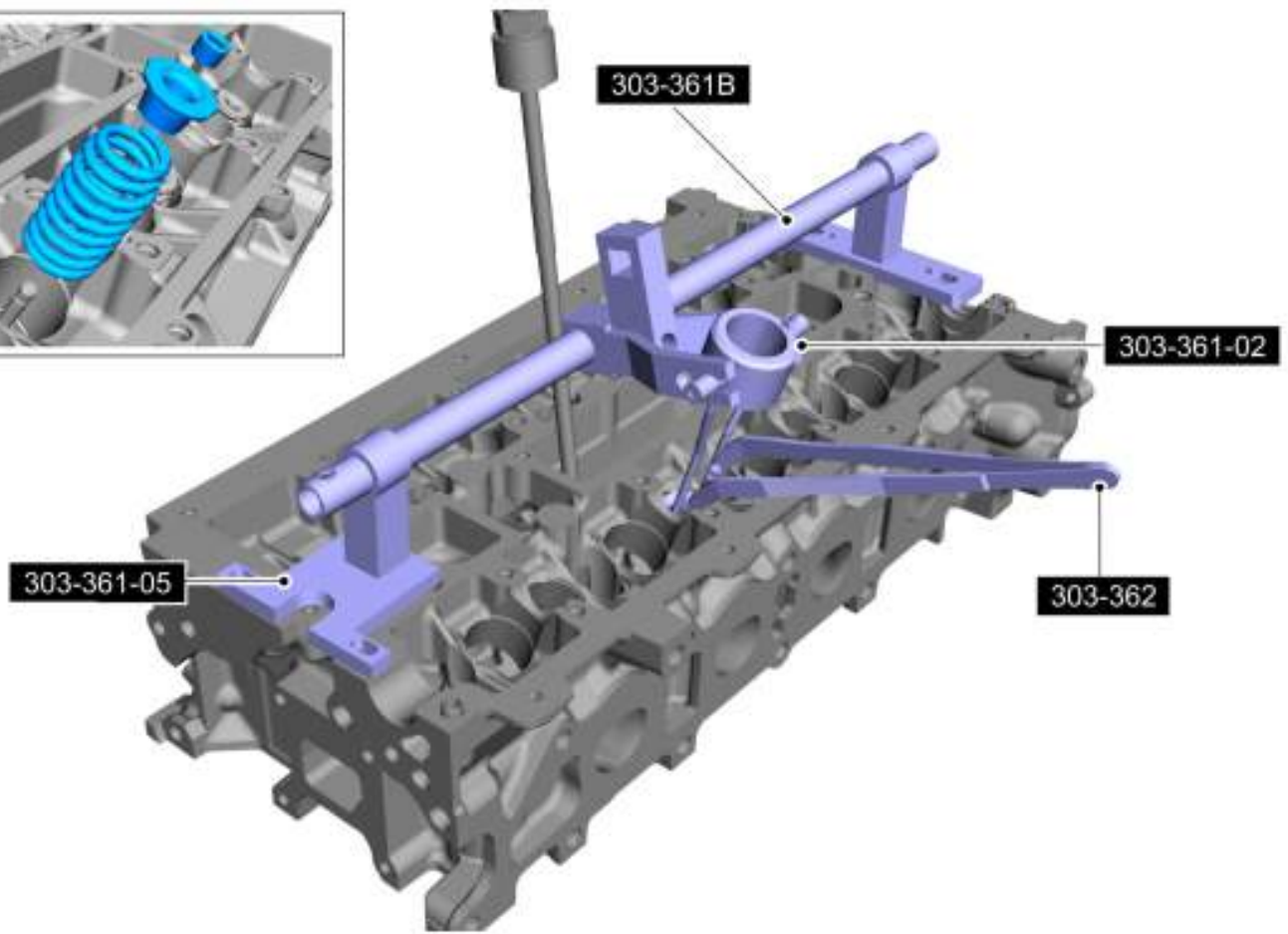

E66113

5. **NOTE:** *Make sure that a new component is installed.*

Use Special Service Tool: 303-508 Pliers, Valve Stem Seal.



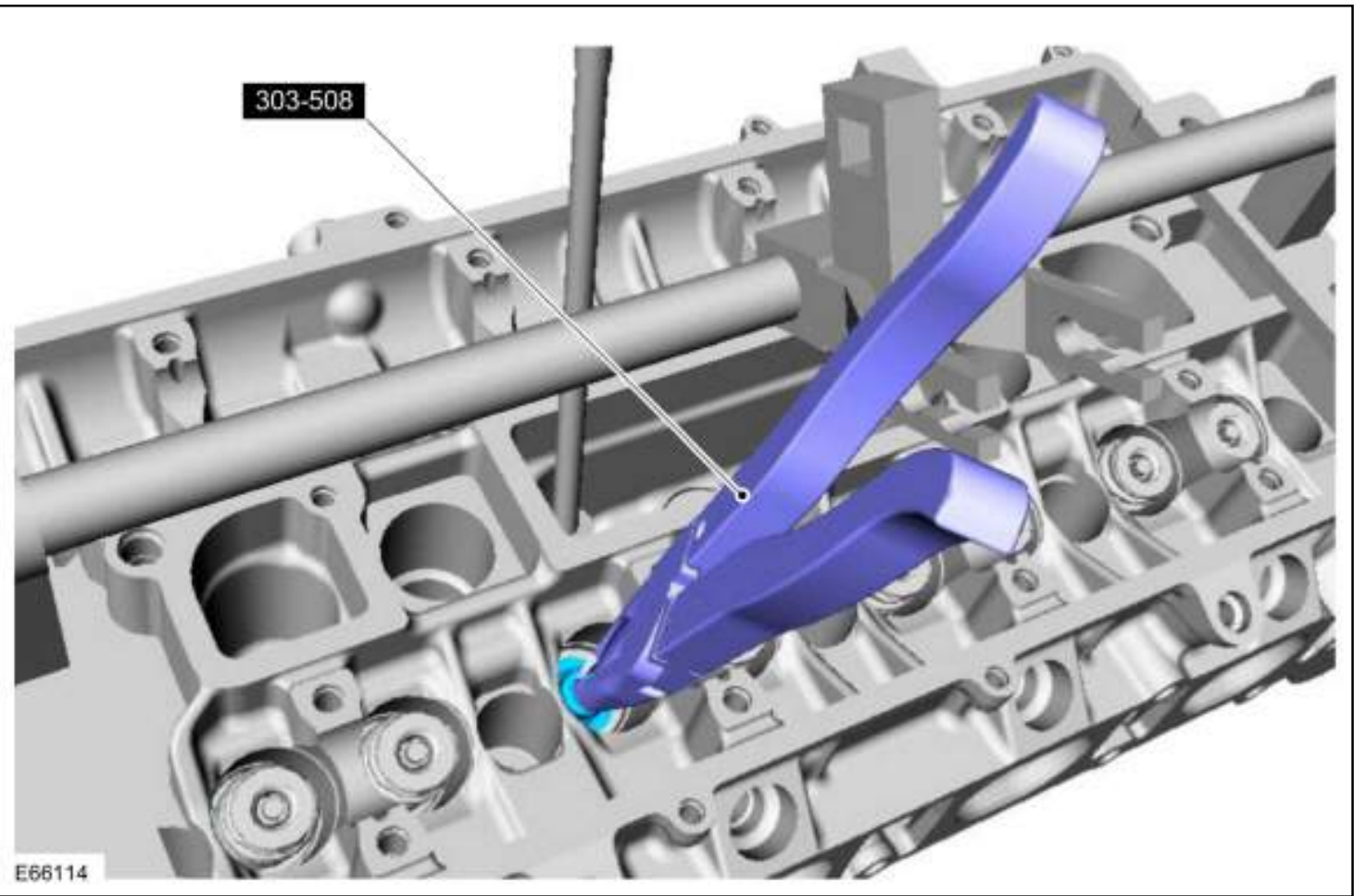

**Installation**

- 1. To install, reverse the removal procedure.



# Oil Cooler

## Special Tool(s) / General Equipment

Hose Clamp(s)
---------------

Hose Clamp Remover/Installer
------------------------------

## Removal

**NOTE:** Removal steps in this procedure may contain installation details.

1. Refer to: Battery Disconnect and Connect (414-01) .
- 2.

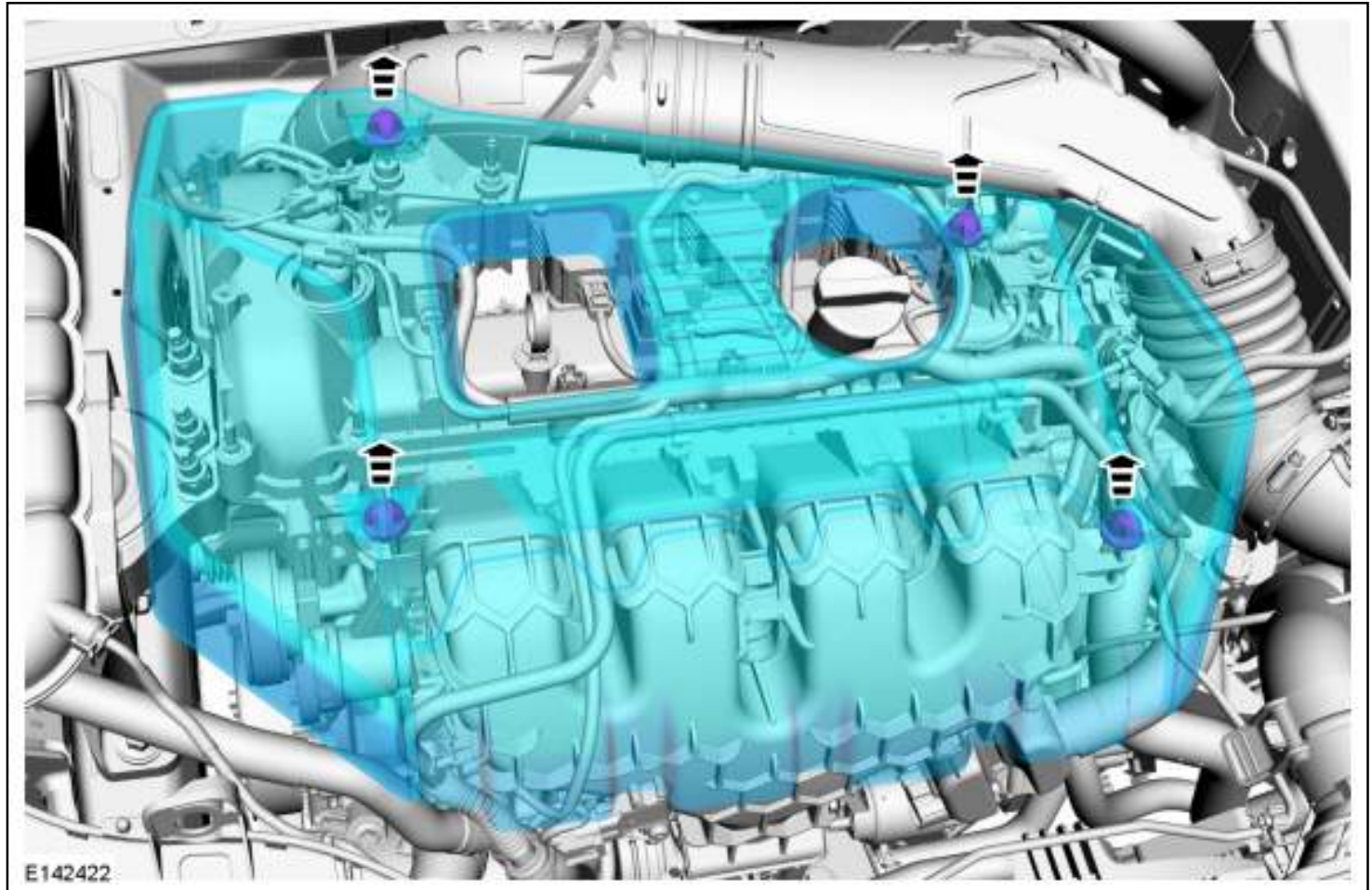

- 3.

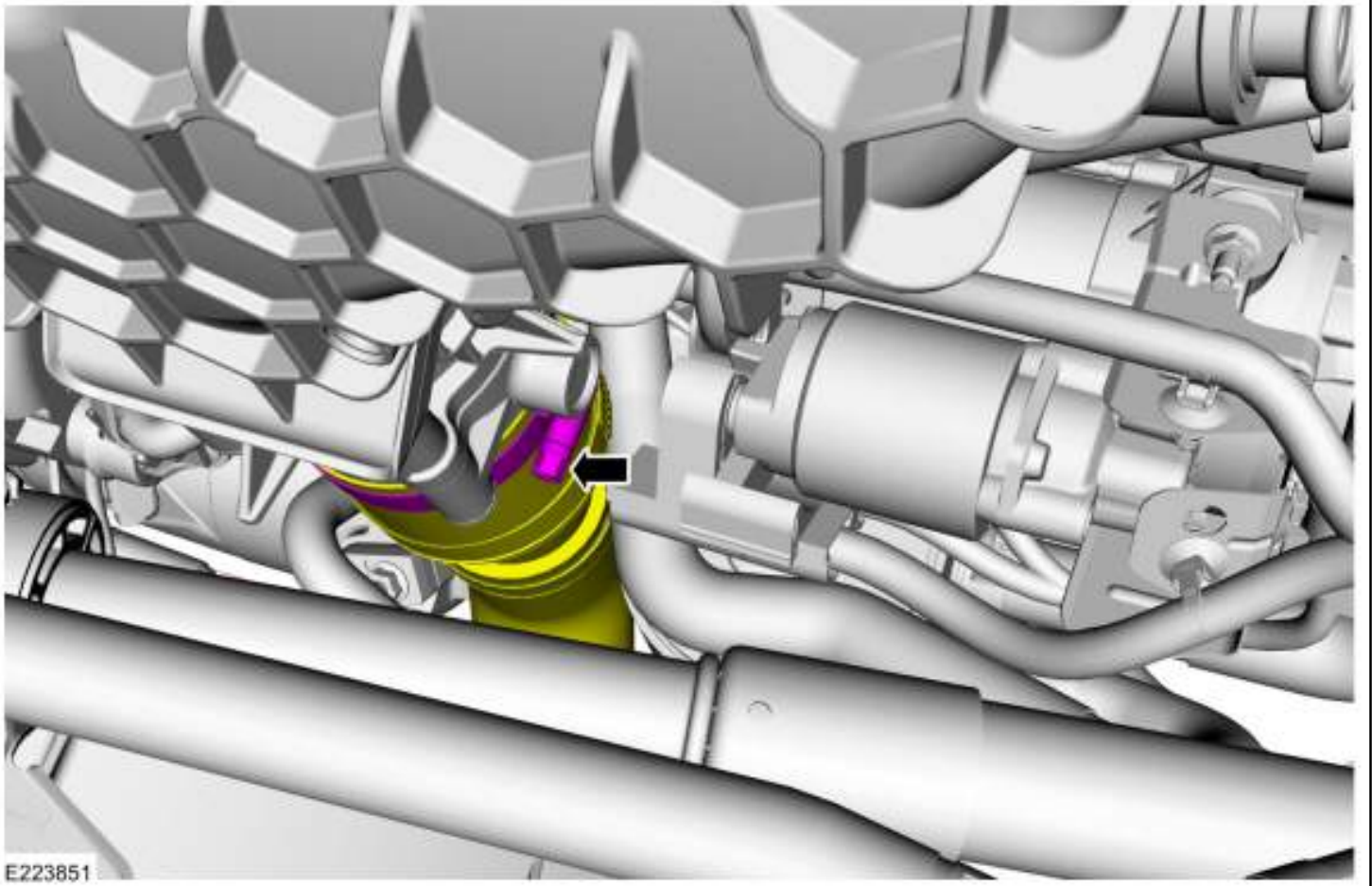

1. *Torque:* 106 lb.in (12 Nm)
2. *Torque:* 159 lb.in (18 Nm)

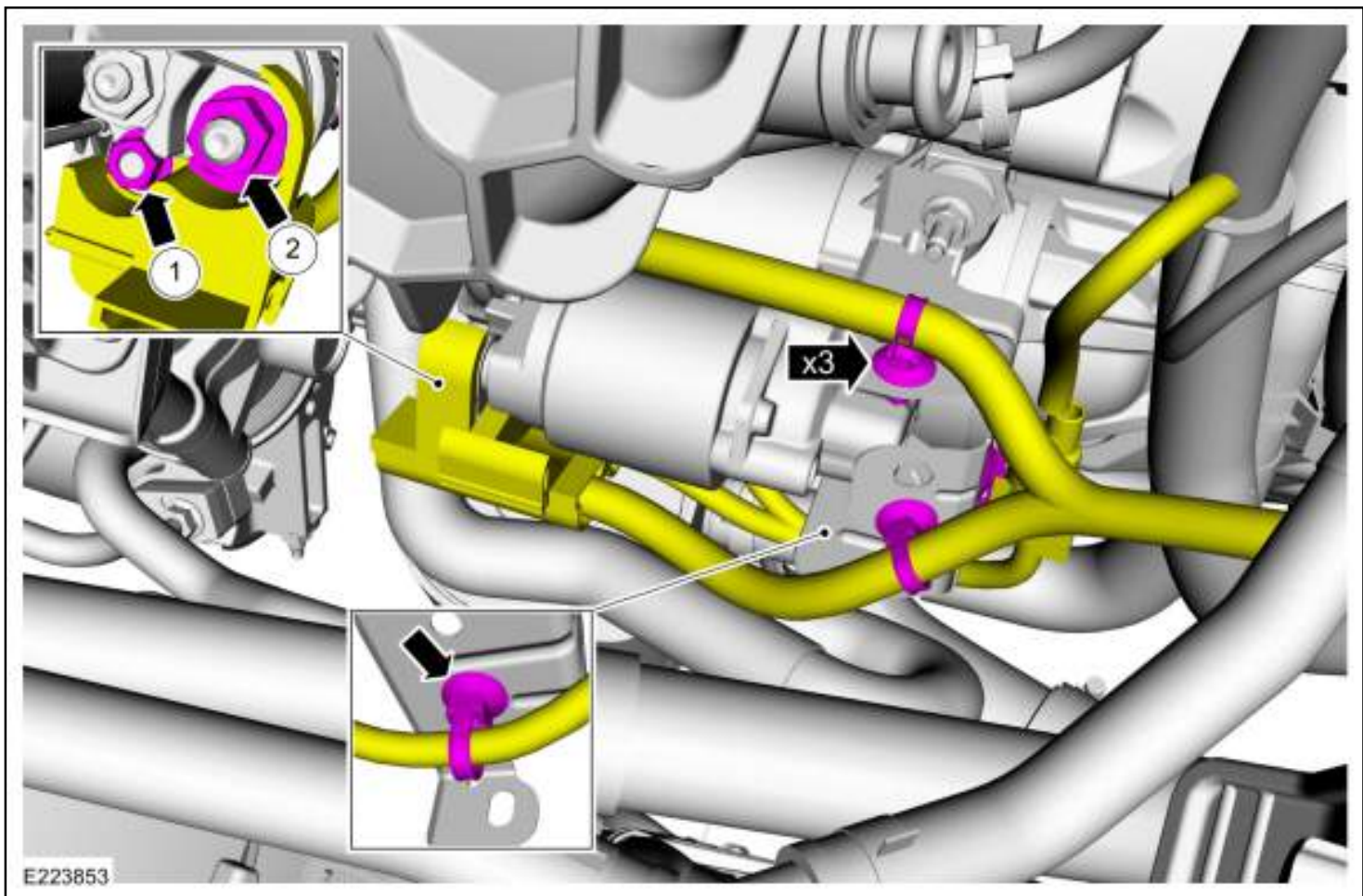

1. Use the General Equipment: Hose Clamp(s)
2. **NOTE:** *Make sure that the mating faces are clean and free of foreign material.*

*Torque:*

Stage 1: 17 lb.ft (23 Nm)

Stage 2: 75°

Stage 3: 15°

3. **NOTE:** *Be prepared to collect escaping fluid.*

Use the General Equipment: Hose Clamp Remover/Installer

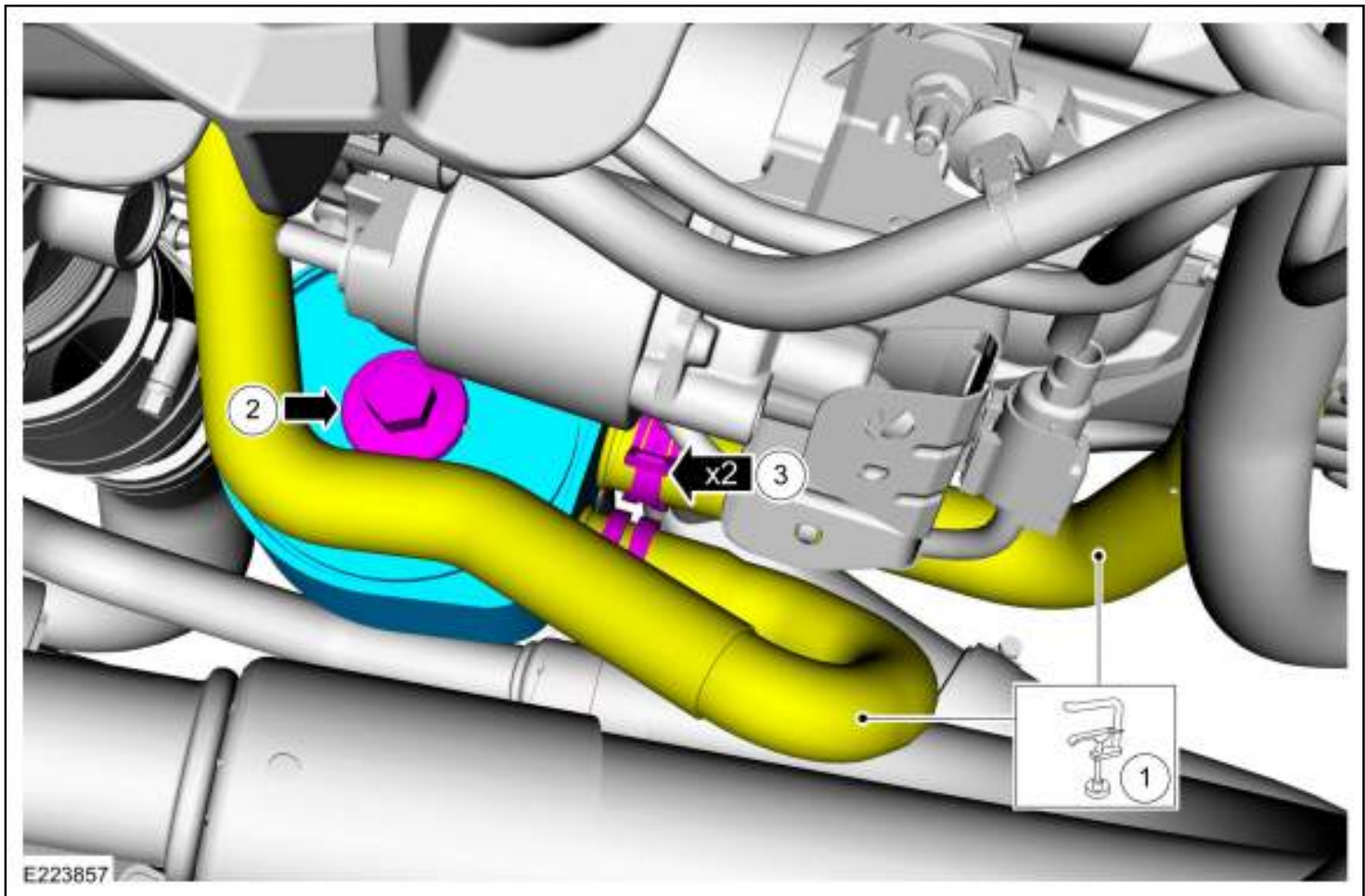

**Installation**

1. To install, reverse the removal procedure.
2. **NOTE:** Make sure that fluid level is to the MAX mark.

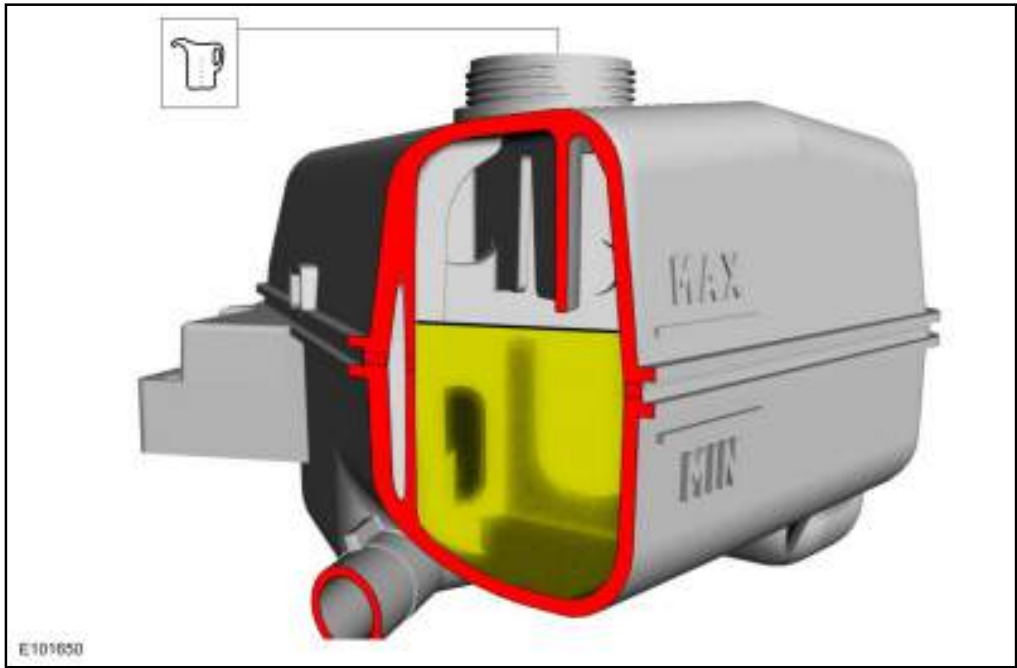



# Intake Manifold

Base Part Number: Base Part Number: 9424

## Removal

**NOTE:** Removal steps in this procedure may contain installation details.

1.

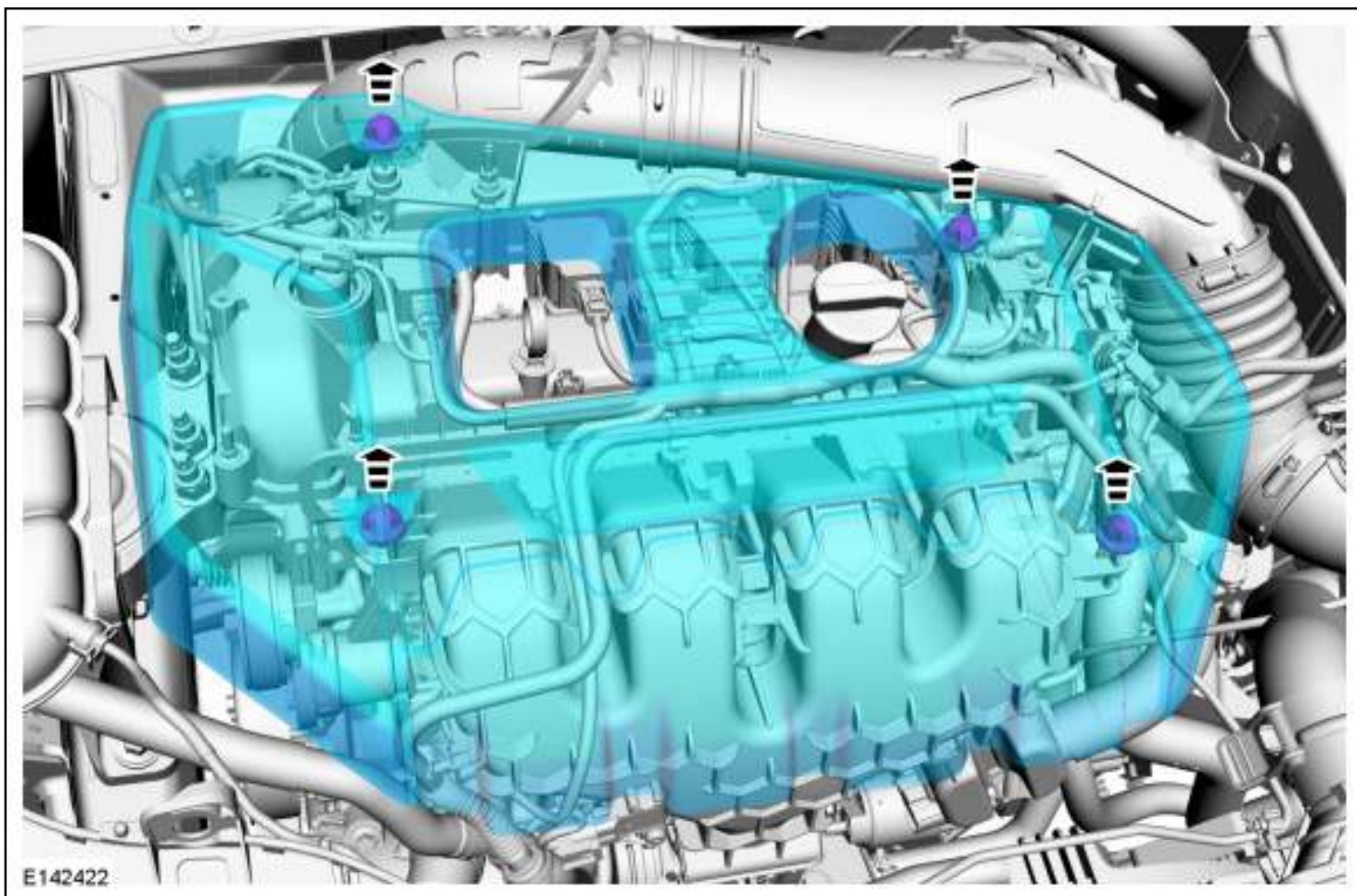

2.

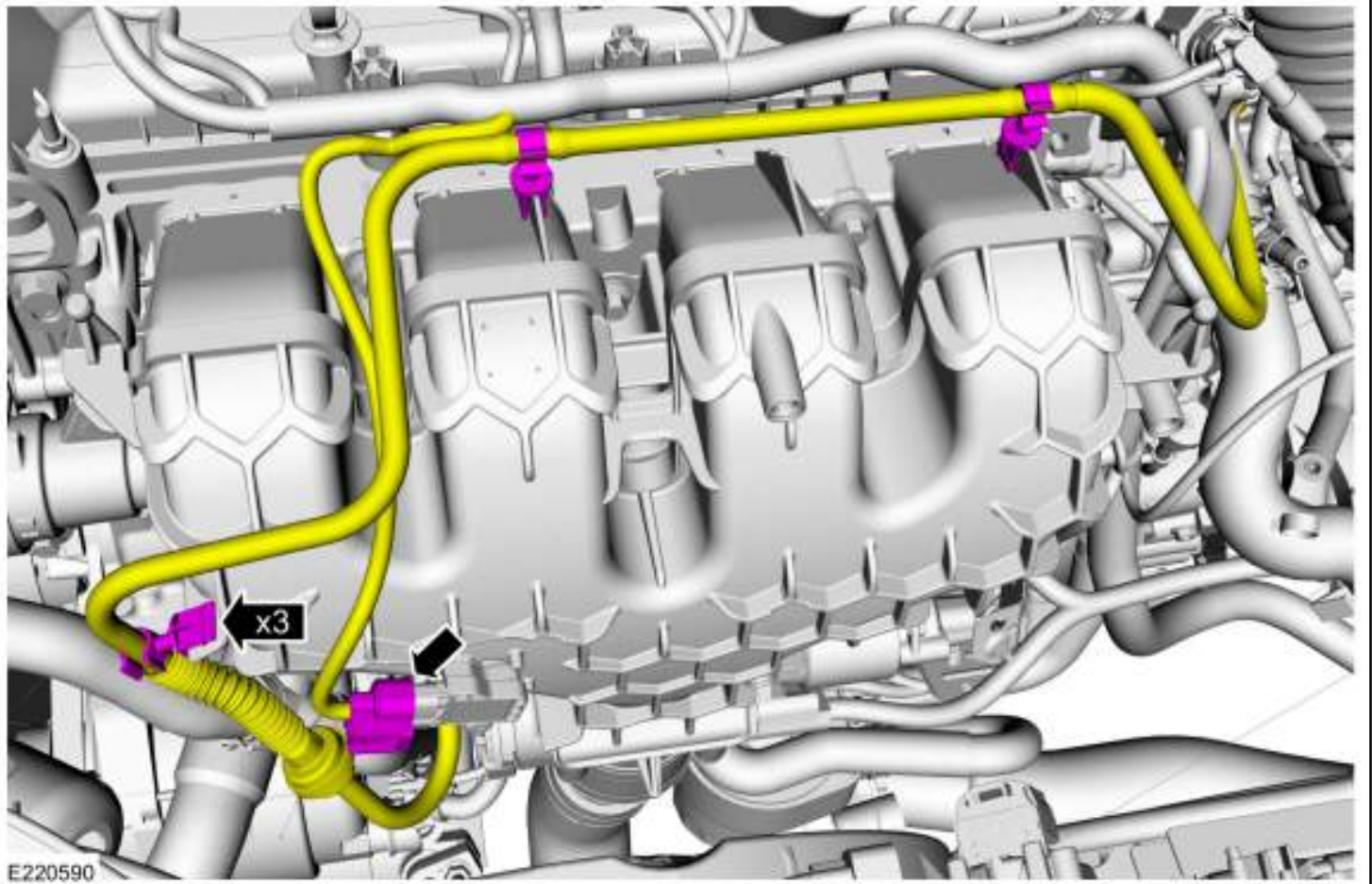

3. Refer to: Quick Release Coupling (310-00 Fuel System - General Information - 2.3L EcoBoost (257kW/350PS) - MI4) .

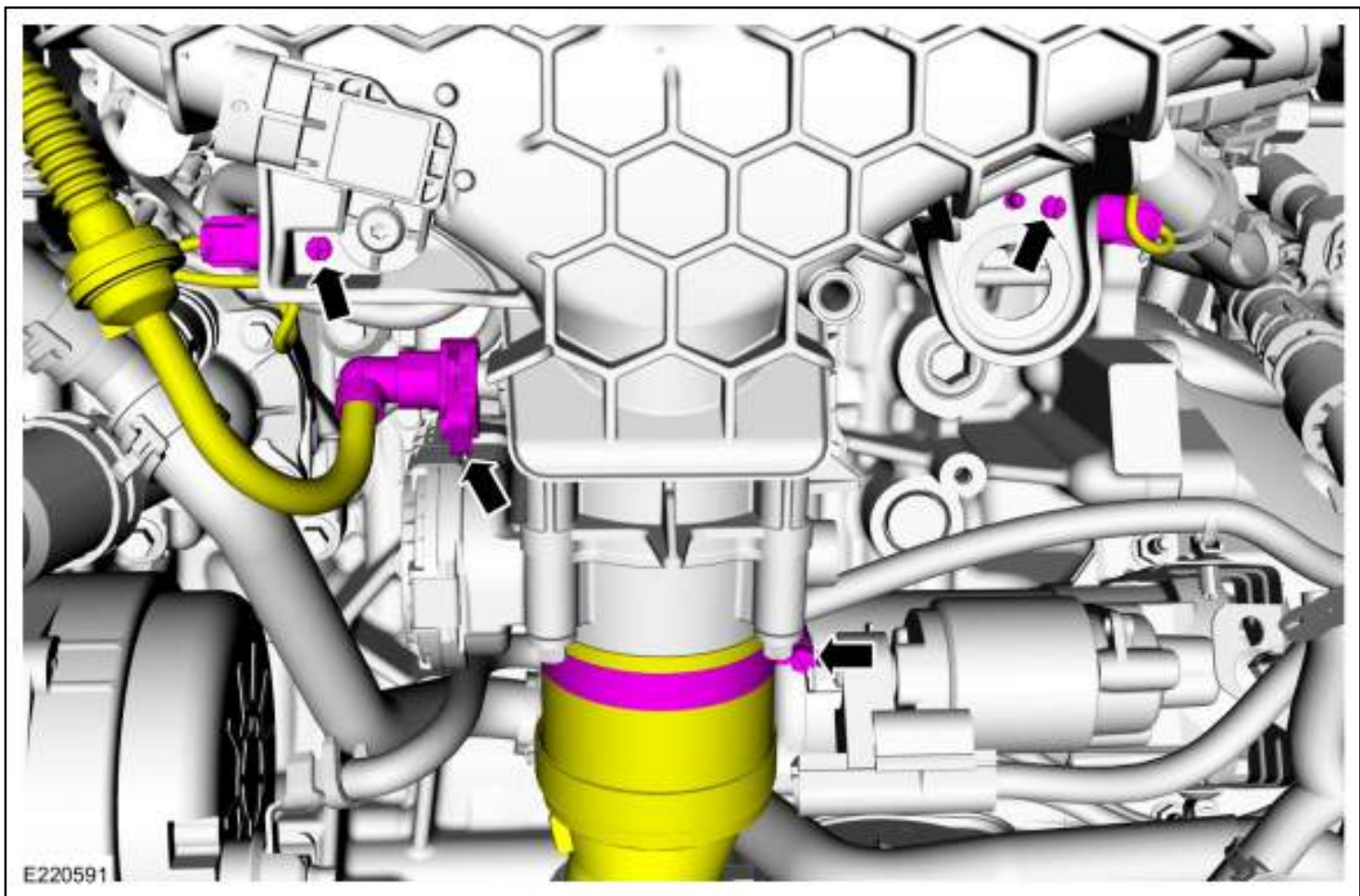

4. **NOTE:** *The gaskets are to be reused unless damaged.*

Refer to: Quick Release Coupling (310-00 Fuel System - General Information - 2.3L EcoBoost (257kW/350PS) - MI4) .

*Torque: 177 lb.in (20 Nm)*

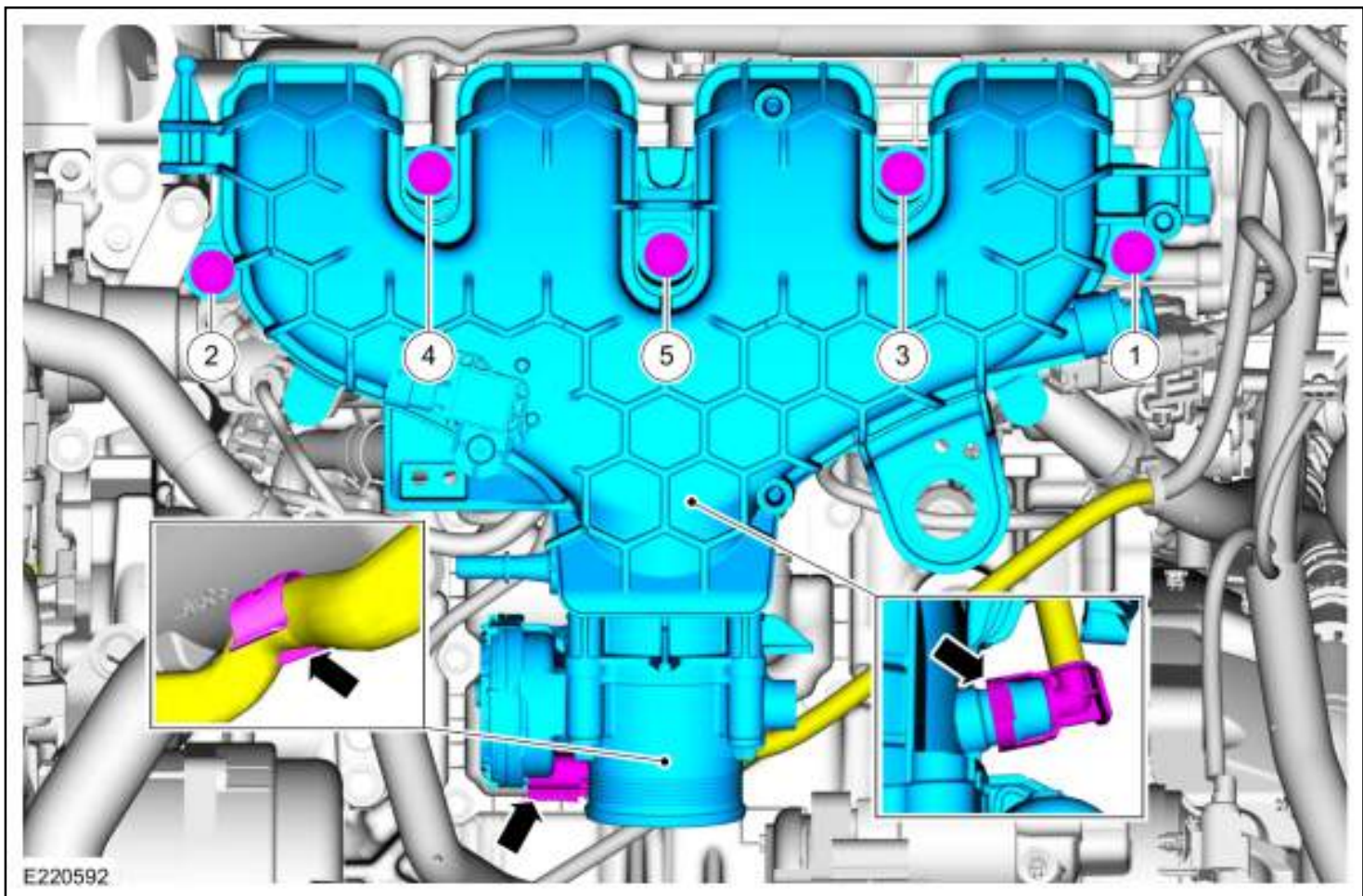

### Installation

1. To install, reverse the removal procedure.

Copyright © 2019 Ford Motor Company



# Flywheel

## Special Tool(s) / General Equipment

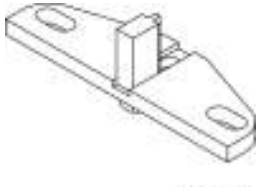
 E55029	303-393-02 Adapter for 303-393 TKIT-2012A-FL TKIT-2012A-ROW
 E63417	303-393A Locking Tool, Flywheel TKIT-2012A-FL TKIT-2012A-ROW

## Removal

1. Refer to: Clutch Disc and Pressure Plate (308-01 Clutch - 6-Speed Manual Transmission - MMT6).
- 2.

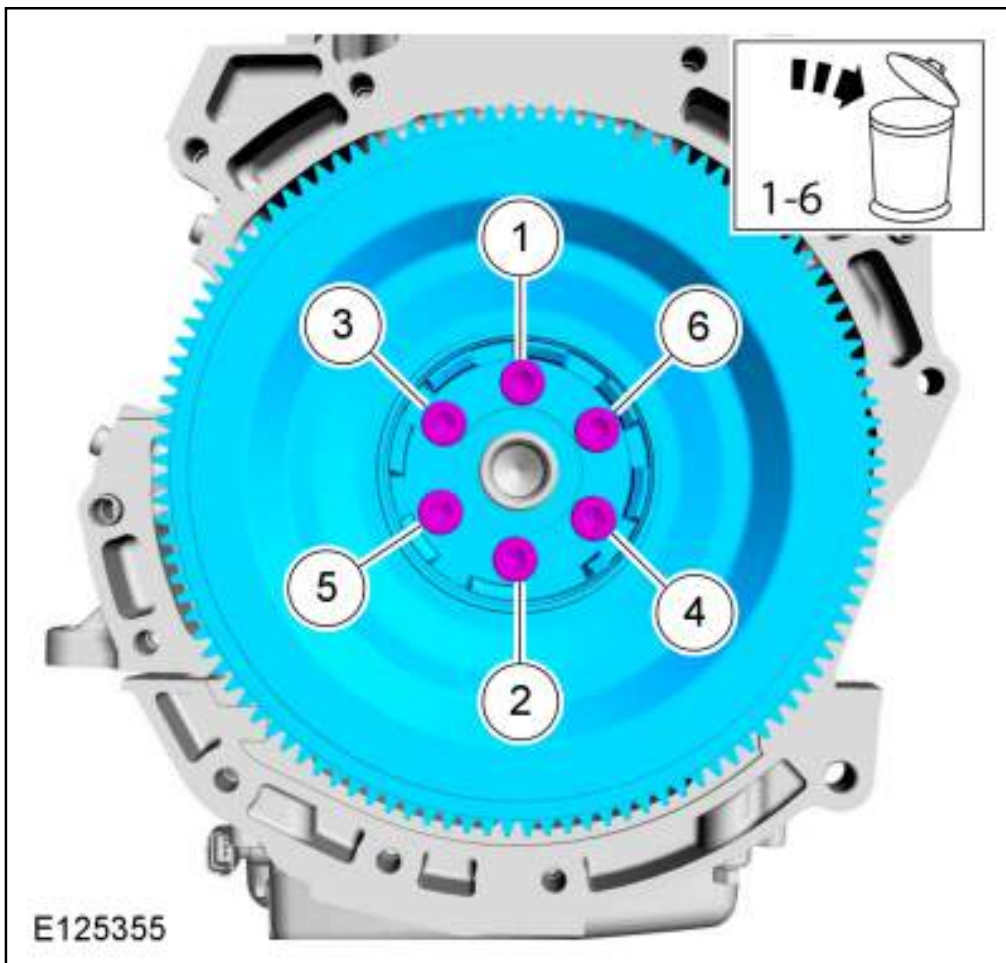

## Installation

1. **NOTE:** *Make sure that new bolts are installed.*

Use Special Service Tool: 303-393A Locking Tool, Flywheel. , 303-393-02 Adapter for 303-393.

*Torque:*

- Stage 1: 37 lb.ft (50 Nm)
- Stage 2: 59 lb.ft (80 Nm)
- Stage 3: 83 lb.ft (112 Nm)

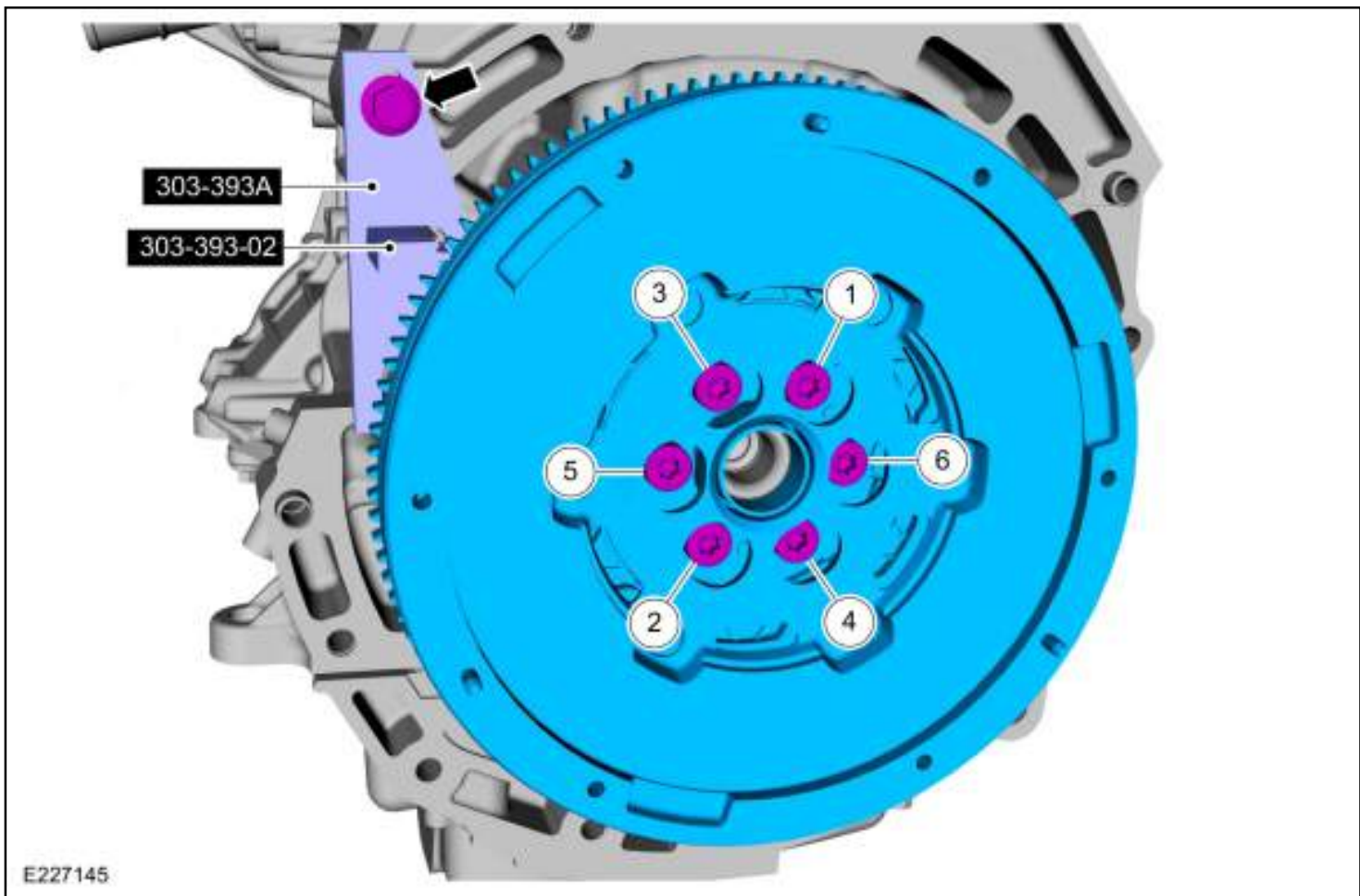

2. Refer to: Clutch Disc and Pressure Plate (308-01 Clutch - 6-Speed Manual Transmission - MMT6) .
3. After completing the repairs, perform the Misfire Monitor Neutral Profile Correction procedure.

Copyright © 2019 Ford Motor Company



# Crankshaft Rear Seal

Base Part Number: Base Part Number: 6701

## Materials

Name	Specification
Motorcraft® Metal Surface Prep Wipes ZC-31-B	-

## Removal

1. Remove the following items:
  1. Refer to: [Flywheel](#) (303-01C Engine, Removal and Installation).
  2. Refer to: [Oil Pan](#) (303-01C Engine, Removal and Installation).
- 2.

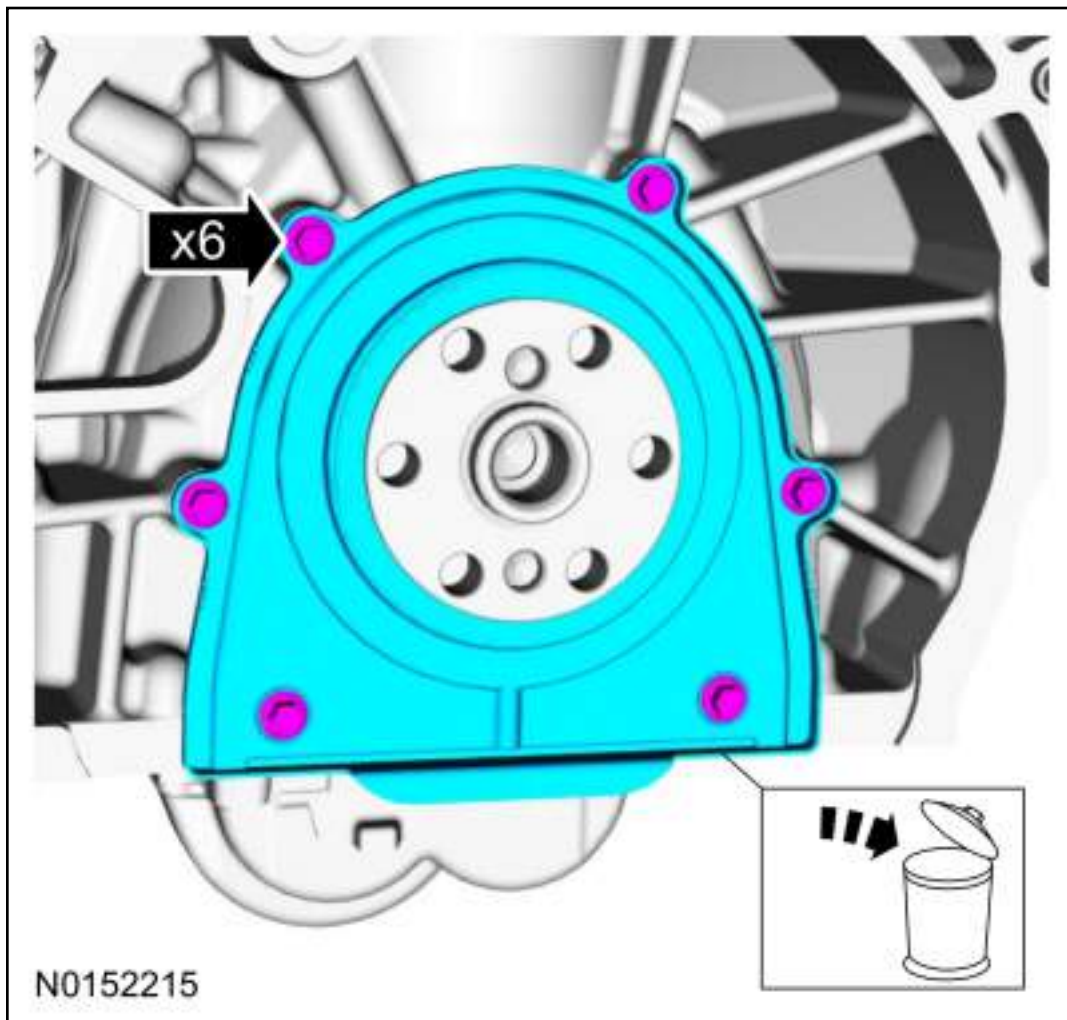

## Installation

1. **NOTE:** *Make sure that the component is clean, free of foreign material and lubricant.*

*Material:* Motorcraft® Metal Surface Prep Wipes / ZC-31-B

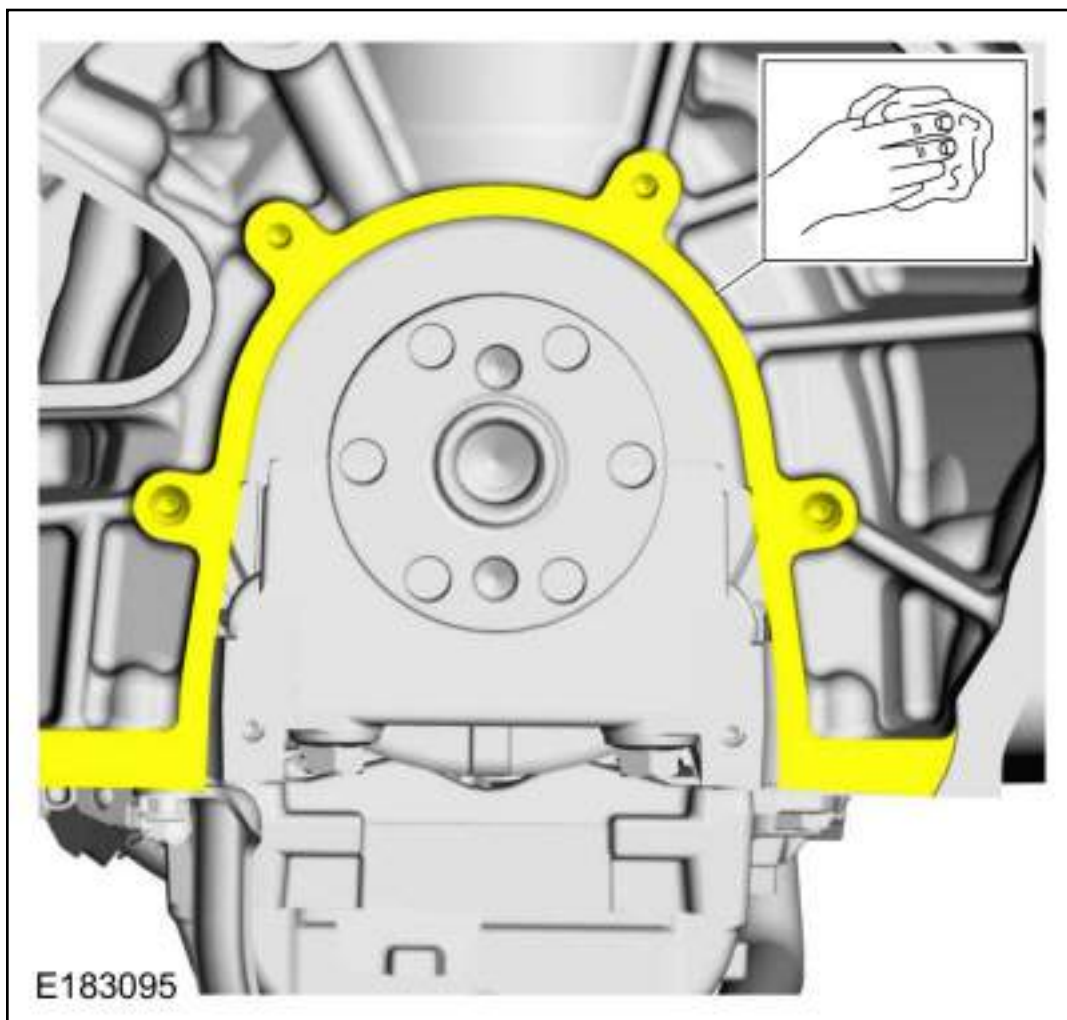

2. **NOTE:** *Make sure that a new component is installed.*

**NOTE:** *New crankshaft rear seal carriers are supplied with an alignment sleeve which must be removed after installation.*

*Torque: 89 lb.in (10 Nm)*

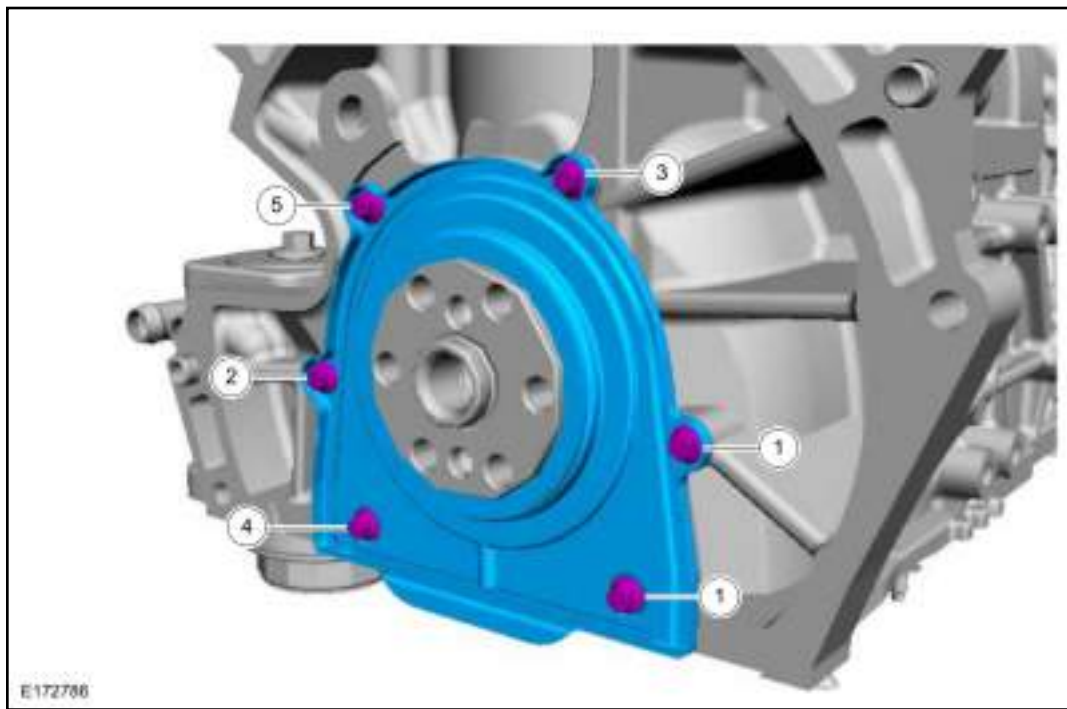

3. Install the following items:

1. Refer to: [Oil Pan](#) (303-01C Engine, Removal and Installation).
2. Refer to: [Flywheel](#) (303-01C Engine, Removal and Installation).

Copyright © 2019 Ford Motor Company



# Specifications

## Materials

Name	Specification
Engine Oil - SAE 0W-40	WSS-M2C937-A

## Engine

Item	Specification	
Engine code	YVDB	YVDA
Emission level	V	Stage VI
Engine capacity	2294 cm <sup>3</sup>	
Power output at 5900 rpm	257 kW (350 PS)	
Maximum torque at 2000-4500 rpm	440 Nm	
Idle speed	760 rpm	
Bore	3.4449 in (87.5 mm)	
Stroke	3.7008 in (94 mm)	
Firing order	1-3-4-2	
Compression ratio	9.4:1	
Maximum oil consumption	0.5l/ 1000 km	
Camshaft drive	Chain	

## Lubricants

Viscosity	Specification
-----------	---------------

SAE 0W-40

*Material: Engine Oil - SAE 0W-40 (WSS-M2C937-A)***Engine Oil Capacity**

<b>Item</b>	<b>Specification</b>
Initial oil fill	6.6 qt (6.2 L)
Service oil fill excluding oil filter	5.4 qt (5.1 L)
Service oil fill including oil filter	5.7 qt (5.4 L)

**Oil Pressure**

<b>Item</b>	<b>Specification</b>
Oil pressure (hot @ 2,000 rpm)	29–60 psi (2–4.14 bar)

**Cylinder Block**

<b>Item</b>	<b>Specification</b>
Head gasket surface flatness	0.1 mm (0.0039 in) - 0.05 mm (0.002 in)/200 mm (7.874 in) x 200 mm (7.874 in)

**Cylinder Head**

<b>Item</b>	<b>Specification</b>
Cylinder head flatness	0.08 mm (0.0031 in) maxim overall, a maximum of 0.05 mm (0.0020 in) within 150 mm (5.9055 in) and a maximum of 0.025 mm (0.0010 in) within 25 mm (0.9843 in)

## Valve Tappet

Item	Specification
Valve clearance (engine cold), intake	0.0075–0.0122 in (.19–.31 mm)
Valve clearance (engine cold), exhaust	0.0118–0.0165 in (.3–.42 mm)

Copyright © 2019 Ford Motor Company

---